

INSTRUCTION MANUAL

ELECTRONIC LOAD

PLZ—WU SERIES

APPLICABLE MODELS

RMF 3—WU

PZL 50WU

PLZ 150WU

PLZ 300WU

KIKUSUI ELECTRONICS CORPORATION

(KIKUSUI PART NO. Z1-737-220)

IA001261

Power Requirements of this Product

Power requirements of this product have been changed and the relevant sections of the Operation Manual should be revised accordingly.

(Revision should be applied to items indicated by a check mark)

Input voltage

The input voltage of this product is _____ VAC,
and the voltage range is _____ to _____ VAC. Use the product within this range only.

Input fuse

The rating of this product's input fuse is _____ A, _____ VAC, and _____.

WARNING

- To avoid electrical shock, always disconnect the AC power cable or turn off the switch on the switchboard before attempting to check or replace the fuse.
- Use a fuse element having a shape, rating, and characteristics suitable for this product. The use of a fuse with a different rating or one that short circuits the fuse holder may result in fire, electric shock, or irreparable damage.

AC power cable

The product is provided with AC power cables described below. If the cable has no power plug, attach a power plug or crimp-style terminals to the cable in accordance with the wire colors specified in the drawing.

WARNING

- The attachment of a power plug or crimp-style terminals must be carried out by qualified personnel.

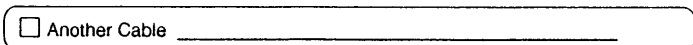
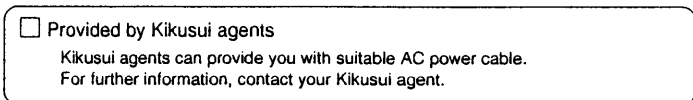
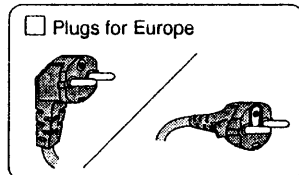
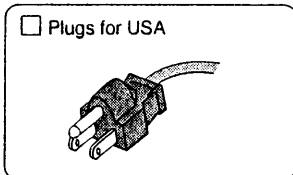
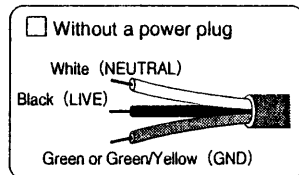
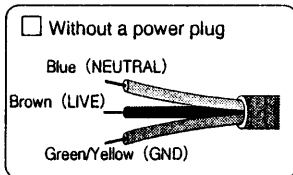

TABLE OF CONTENTS

	<u>PAGE</u>
1 . FEATURES	1
2 . PRECAUTIONS	2
3 . LAYOUT OF COMPONENTS	3
4 . ELECTRICAL CONNECTIONS	5
5 . APPLICATION EXAMPLES	6
6 . LOCAL CONTROL	8
7 . REMOTE CONTROL	8
8 . MONITORS	13
9 . ALARMS	13
10 . RACK MOUNT FRAME, RMF3-WU	14
11 . TO INSTALL LOAD UNIT(S) IN RACK MOUNT FRAME	16
12 . INSTALLING BLANK PANEL(S)	18
13 . SPECIFICATIONS	19
14 . OVERALL DIMENSIONS	23
15 . OPERABLE RANGE CHARTS	24

Introduction

The Electronic Load, Series PLZ-WU, is a versatile device with features as described below.

Be sure to read this manual before using the Electronic Load in order to make the correct use of it.

1. < FEATURES >

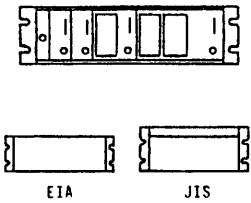
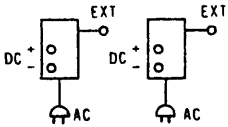
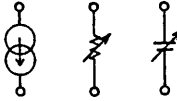
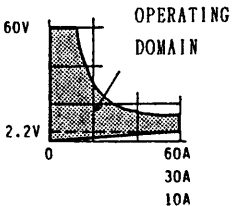
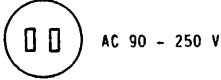
 <p style="text-align: center;">EIA JIS</p>	<ul style="list-style-type: none"> ◦ The PLZ-WU is of a unit structure and housed in a rack mount frame. The frame can be installed on an EIA or JIS standard cabinet. (The model number of the frame is RMP3-WU.)
	<ul style="list-style-type: none"> ◦ Individual units of PLZ-WU are mutually isolated.
	<ul style="list-style-type: none"> ◦ The PLZ-WU can operate in a constant current, constant resistance or constant voltage mode, and can be remote-controlled when in constant current or constant voltage mode.
 <p style="text-align: center;">OPERATING DOMAIN</p>	<ul style="list-style-type: none"> ◦ The PLZ-WU has a wide operation range and can draw the rated maximum current with 2.2 volts DC.
	<ul style="list-style-type: none"> ◦ The PLZ-WU can operate on an AC line voltage of 90 V - 250 V, without requiring any switching over or modification of the AC line power input circuit.

2. < PRECAUTIONS >

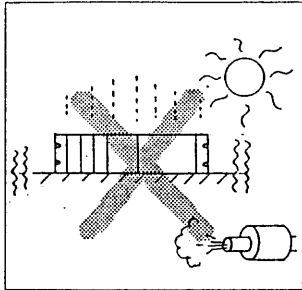
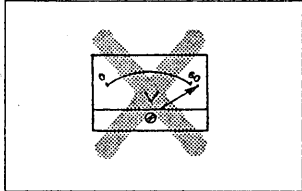
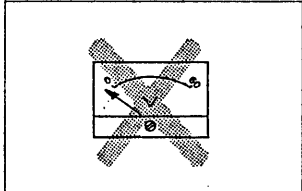
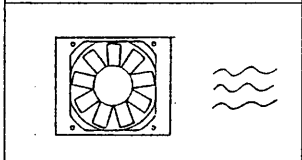
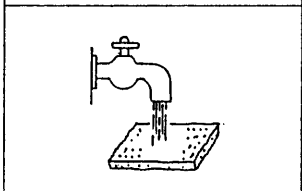
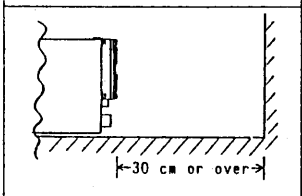
	<p>○ Do not expose the PLZ-WU to heat (direct sunlight), dusty or corrosive atmosphere, mechanical vibration, or other adverse environment.</p>
	<p>○ Do not apply a voltage of 60 volts DC or more to the input circuit of the Load. Note that the Load may be damaged if such voltage is applied to it.</p>
	<p>○ When applying a voltage or feeding a current to the Load, make certain that it is connected in the correct polarity to the Load. If it is connected in the wrong polarity, the Load may be damaged. (The Load has a fuse to protect it against this type of failure.)</p>
	<p>○ The Load units are cooled by the fan of the rack mount frame. Do not use the units being removed from the frame.</p>
	<p>○ Clean the dust filter at appropriate intervals. If it is clogged, cooling power will be degraded.</p>
	<p>○ Do not block the fan air outlet. Keep a clearance of 30 cm at least from the air outlet.</p>

876271

3. <LAYOUT OF COMPONENTS>

The layout of the control switches, indicator lamps and other components of the PLZ-WU is as shown in this section.

o Front Panel

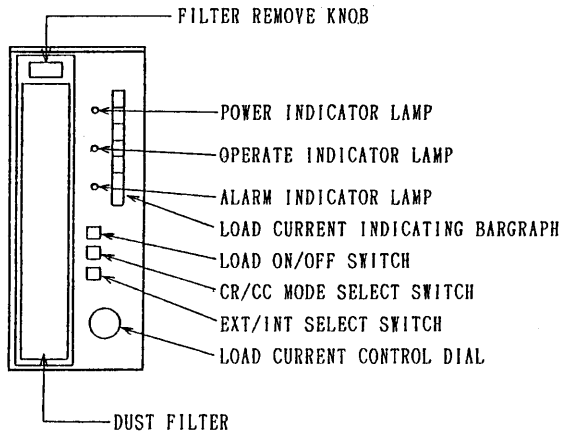
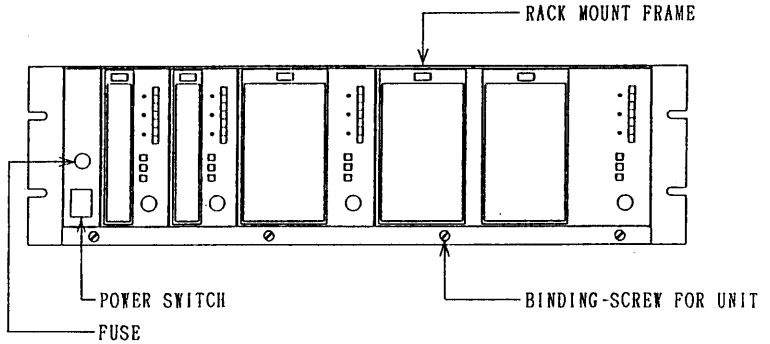

o Rear Panel

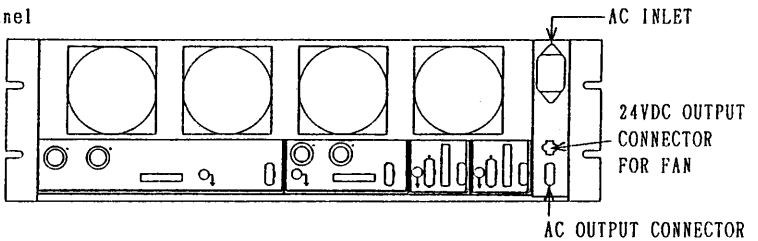

o Rear Panel of Load Unit

PLZ150WU

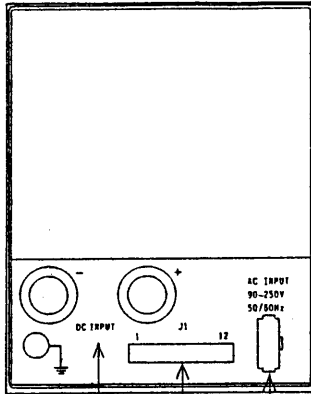

DC INPUT CONNECTOR
 REMOTE CONTROL CONNECTOR
 AC INPUT CONNECTOR

PLZ50WU

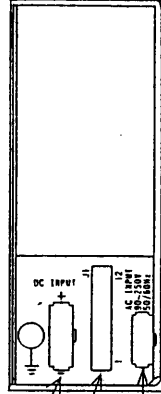

DC INPUT CONNECTOR
 REMOTE CONTROL CONNECTOR
 AC INPUT CONNECTOR

PLZ300WU

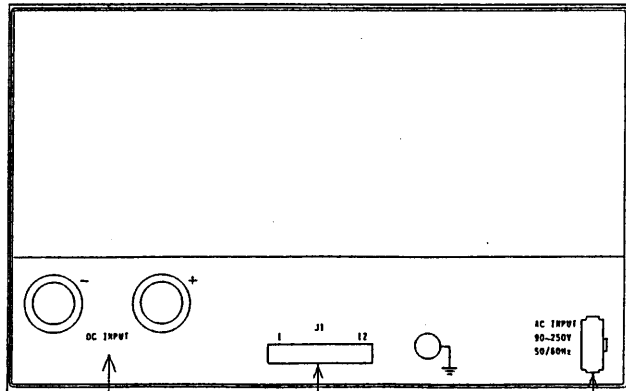

DC INPUT CONNECTOR
 REMOTE CONTROL CONNECTOR
 AC INPUT CONNECTOR

4. <ELECTRICAL CONNECTIONS>

For electrical connections between the rack mount frame and the Load units, cables are provided as shown in Figure 4-1.

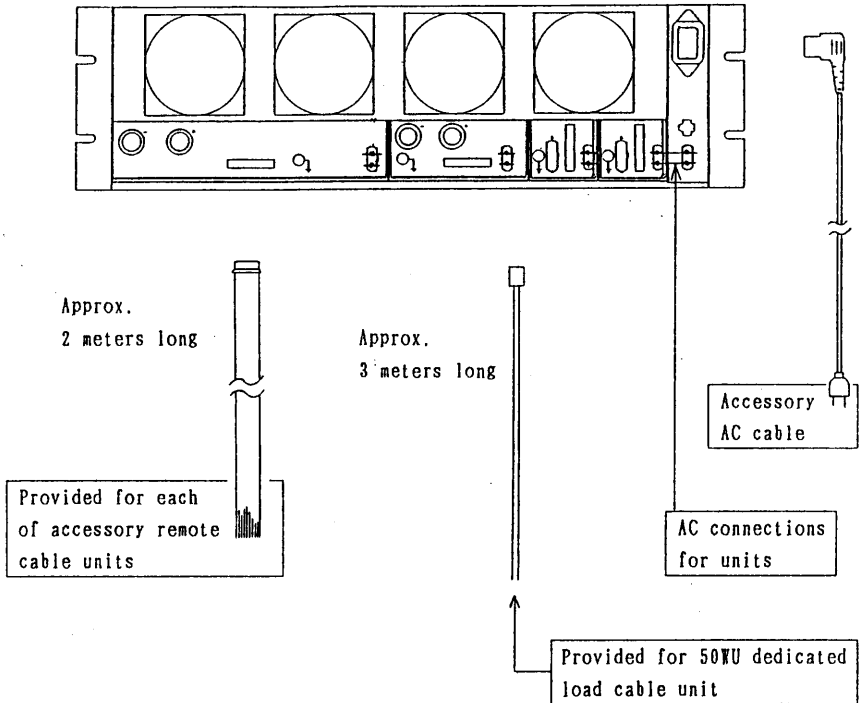
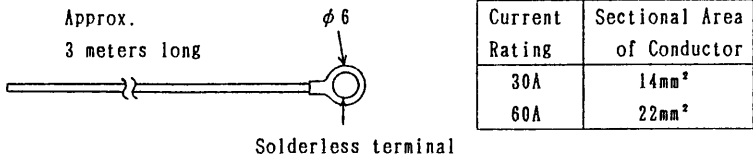

Figure 4-1

No load cables are provided accompanying Models PLZ150WU and PLZ300WU Electronic Loads, for which load cables should be prepared by the user as follows.



Note: Note that noise may be introduced if a remote control cable or a load cable longer than the standard length is used.

5. <APPLICATION EXAMPLES>

Typical application examples of the Electronic Load are illustrated in this section.

Constant Current Mode

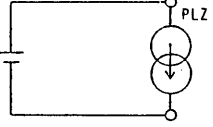
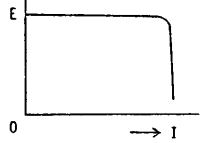
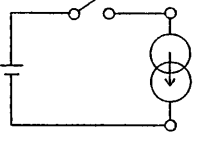
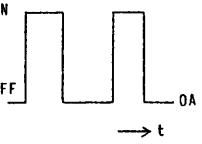
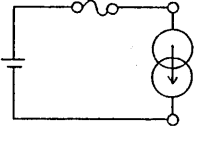
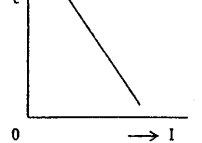
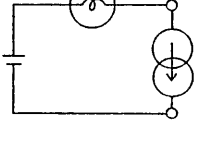
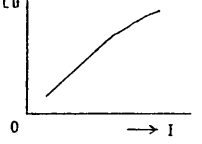
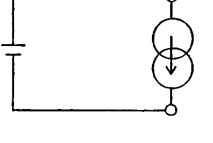
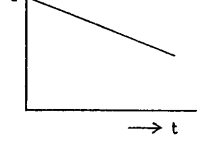
Type of Test	Test Setup	Test Characteristics
Load Test of Regulated DC Power Supply		
Contact Test		
Fuse Test		
Lamp Test		
Constant-current Discharge Test of Battery		

Constant-current setting can be remote-controlled.

Constant Voltage Mode

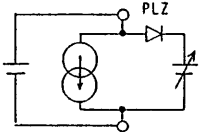
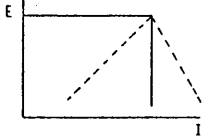
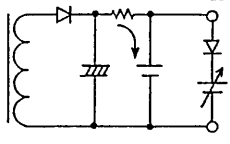
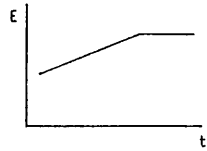
Type of Test	Test Setup	Test Characteristics
Drooping Characteristic Test	 <p>The diode is a VF zero-volt equivalent one.</p>	
To Prevent Overcharge		

Constant voltage setting can be done only in the remote control mode.

Constant Resistance Test

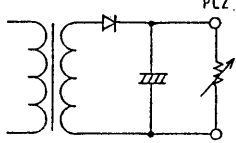
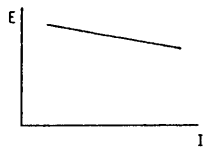
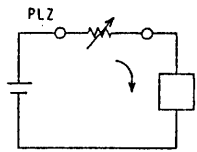
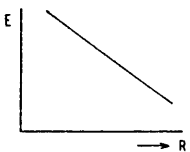
Type of Test	Test Setup	Test Characteristics
Load Test of Transformer		
To Limit Current		

The constant-resistance mode remote-control feature is optional.

CR01-PLZ: Factory-installed option

876976

6. <Local Control>

◦ Setting of Controls for Constant Current Mode

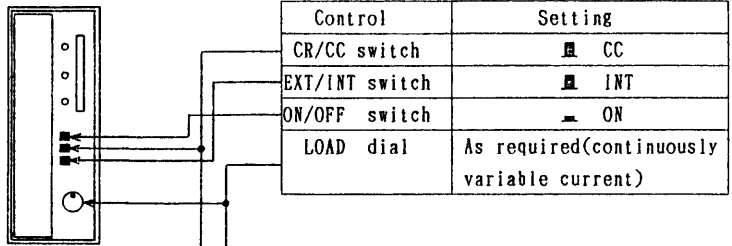

◦ Setting of Controls for Constant Resistance Mode

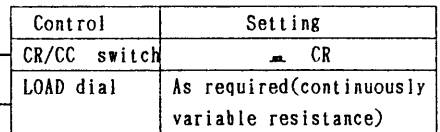

7. <Remote Control>

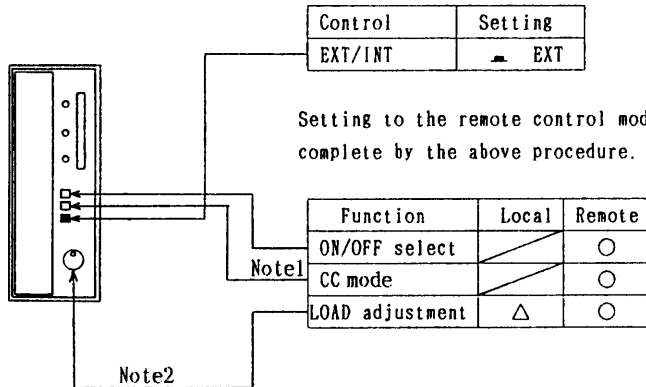

Note1: CR mode can't be remote-controlled.

Note2: Turn to the full clockwise position. Adjustment is effective even when in the remote control mode.

o Table of Remote Control Functions
 The digital signal is of a positive logic.

Pin No.	Function	Signal Level	Recommendable external circuit
12	NC		
11	NC		
10	Not used		Contact
9	Load ON(operate)	L (Internal pull up)	When connecting the cables, make certain that the connections are in the correct polarity. Voltage approx. 12 V
8	Not used		0.4mA
7	Digital ground	Ground	Fanout, approx. 4 mA
6	CC mode current change	0~10V	
5	CV mode voltage change	0~10V	
4	Analog ground	Ground	
3	Current monitor output	FS/1V	
2	Alarm	Open collector	
1	Photocoupler isolation	Emitter	

Observe that the connections are in the correct polarity.

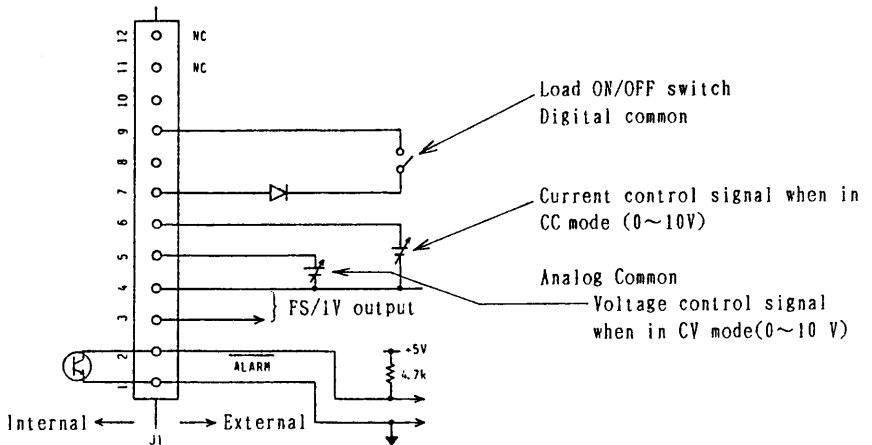

◦ Remote Control Cable (Accessory)

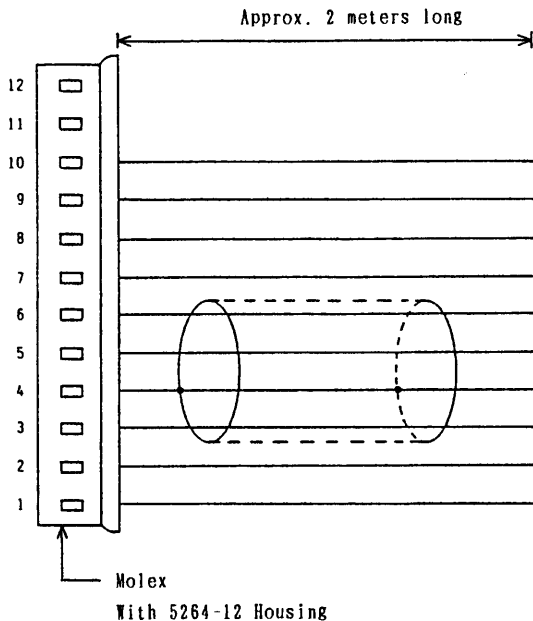

No. 8 and 10 are not used.

Use this accessory when operating the PLZ-WU in the remote control mode.

◦ Setting of Controls for Constant Current Mode

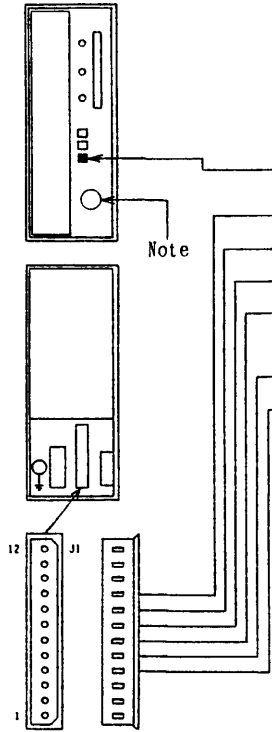

For remote control of the load current in the constant current mode, see the following.

Setting Item	Control Signal Level	Circuit Example	Status
EXT/INT switch			EXT
J1, Pin 9 Pin 8 Pin 7	L OPEN Digital common		ON C.C
J1, Pin 6 Pin 5 Pin 4	DC 0~10V Analog common		Current adjustable

The load current which is set by the analog control voltage is expressed as follows:

$$I_o = K1 \times E_s$$

where, I_o : Load current [ampere]

E_s : Control voltage [volt]

$K1$: Constant, 1 for PLZ50WU

3 for PLZ150WU

6 for PLZ300WU

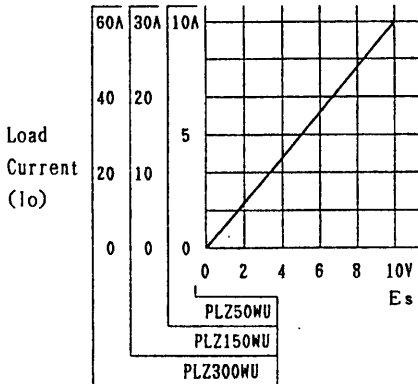

Figure 7-1 shows the relationship of analog control voltage versus load current.

Note: Turn to the full clockwise position. Adjustment is effective even when in the remote control mode.

Figure 7-1

◦ Setting of Controls for Constant Current/Constant Voltage Mode

This mode can be used for test and adjustment of output drooping range of a power supply.

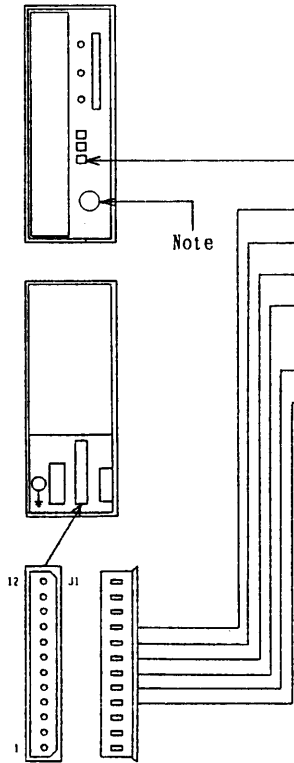

Setting Item	Control Signal Level	Circuit Example	Status
EXT/INT switch			EXT
J1, Pin 9 Pin 8 Pin 7	L OPEN Digital common		ON C.C
J1, Pin 6 Pin 5 Pin 4	DC 0~10V DC 0~10V Analog common		Current adjustable Voltage adjustable

For setting of the controls for the constant current mode, see the preceding page.

The load voltage which is set by the analog control voltage is expressed as follows:

$$E_o = 6 \times E_v$$

Where, E_o : Load voltage [volt]

E_v : Control voltage [volt]

Even when the load current (I_o) is after setting the load voltage (E_o), the output of the tested power supply is maintained at E_o as shown is Figure 7-2.

Example of power supply output characteristics

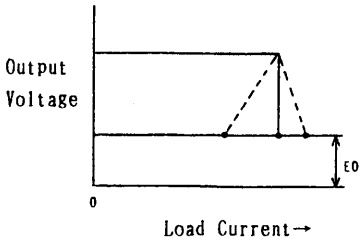
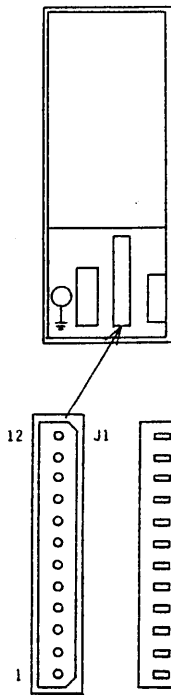

Figure 7-2

Note: Turn to the full clockwise position. Adjustment is effective even when in the remote control mode.

8. <MONITORS>



A monitor signal representing the load current is delivered.

Monitor Terminal	Output Signal	Output Impedance
J1, Pin 4	Analog Common	
Pin 3	FS/1V 2%	Approx. 500 ohms

The monitor signal voltage is $1\text{ V} \pm 2\%$ when at the maximum rated current of the Load.



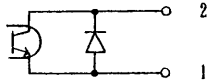

9. <ALARMS>

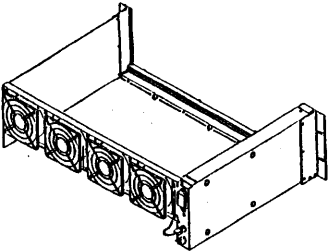
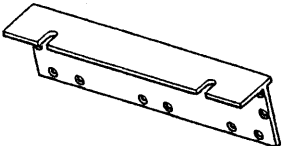
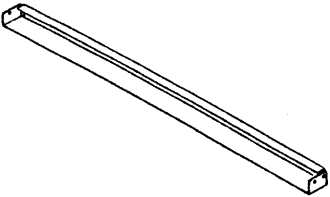

Protected Items	Indication	Output
Overvoltage	Alarm flag	Photocoupler isolated open collector 
Overcurrent		
Overpower		
Overtemperature		
Reverse polarity		

When an alarm is indicated immediately stop operating the Load and eliminate the cause of the alarm.

10. <COMPOSITION OF RACK MOUNT FRAME RMF3-WU>

Item No.	Name	Form	Q'ty
①	Rack mount frame (for EIA rack)		1
②	Brackets (right and left) for JIS rack		2
③	Blank panel for JIS rack		1
④	Screws, flat head M3×6		4
⑤	Screws, oval head M5×14		4
⑥	Finishing washer		4

876984

[For JIS Rack]

To assemble the rack mount frame for a JIS (Japanese Industrial Standard), proceed as follows:

1. Replace the front pillar of the right and left panel units (for EIA rack) ① with the right and left brackets for JIS rack ②, using the original binding-screws for both brackets.

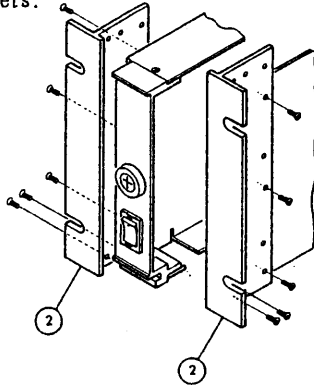

Figure 10-3

2. After installing the Load Unit(s) (See <TO INSTALL LOAD UNIT(S) IN RACK MOUNT FRAME>), fix the blank panel for JIS rack ③ with the screws M3×6 ④.

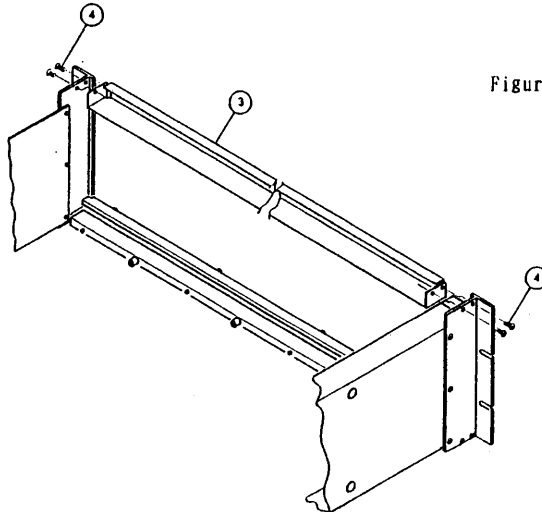

Figure 10-2

Assembly of the rack mount frame for JIS rack is complete by the above procedure.

11. <TO INSTALL LOAD UNIT(S) IN RACK MOUNT FRAME>

To install the Load Unit(s) in the rack mount frame RMF3-WU, follow the instructions given below.

Note: Note that the rack mount frame should be assembled in a different manner depending on whether the rack is of the EIA or JIS standard as mentioned in Section 10.

Installing Procedure

1. Loosen the four unit binding-screws ① at the front of RMF3-WU and widen the gap "A". (B - B view)

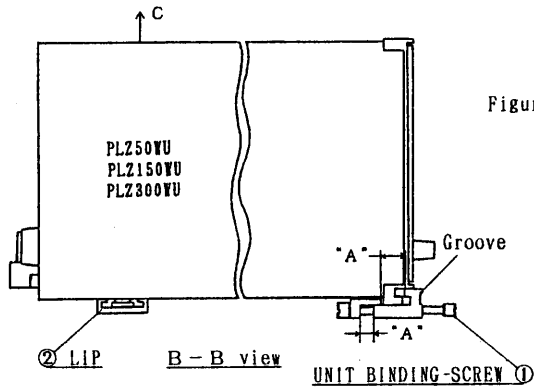

Figure 11-1

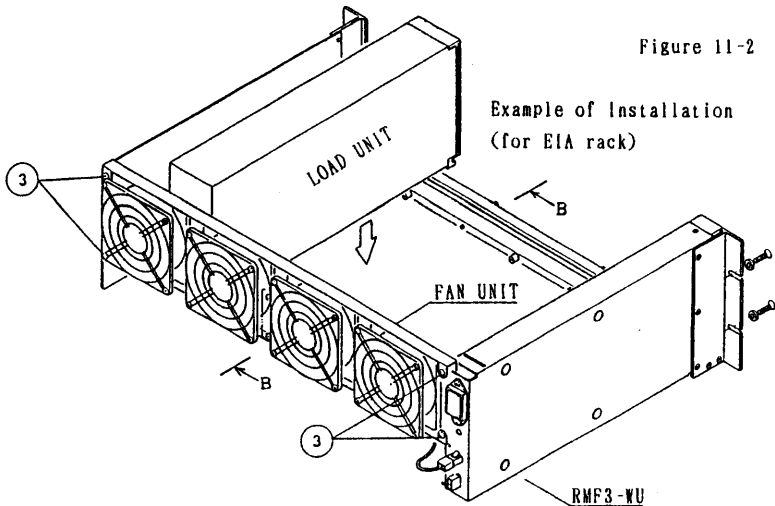

Figure 11-2

2. Loosen the four fan unit binding-screws ③. (The fan unit can move to the rear.)
3. Put the Load Unit in the frame. Make sure that the lip ② is in the groove.
4. Move the Load Unit to the required position (to the right or left as required).
5. Tighten the four unit binding-screws ①.
6. Make sure that the lip ② is securely engaged in the groove.
(This can be made by raising the unit in the C direction shown in Figure 11-1.)
7. Tighten the four fan unit binding-screws ③.

The installation procedure is complete by the above.

- Notes:
1. The groove indicated with the asterisk in Figure 11-1 may be used for identification marks (such as "CH1", "CH2").
 2. Figure 11-2 shows only an example of installation of PLZ50WU. PLZ150WU and PLZ300WU also can be installed in the same manner. Any combination of PLZ50WU, PLZ150WU and PLZ300WU also can be installed.
 3. To cover up the unused void space of the rack mount space, blank panels (BP8-WU, BP4-WU, and BP2-WU) are available as options.

12. <INSTALLING BLANK PANEL>

To cover up the unused void space of the rack mount frame, blank panels are available as shown in Figure 12-1.

Note: Note that the rack mount frame should be assembled in a different manner depending on whether the rack is of the EIA or JIS standard as mentioned in Section 10.

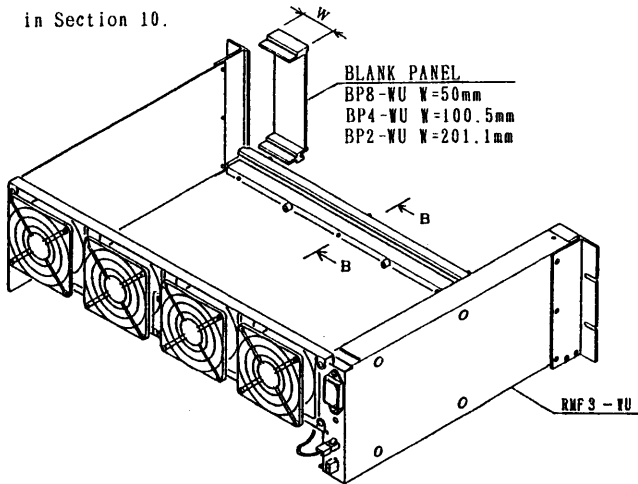

Figure 12-1

To install a blank panel, proceed as follows:

1. Loosen the four unit binding-screws ① at the front of RMF3-WU and widen the gap "A".
(B - B view)
2. Place a blank panel at the required position on the rack mount frame.
(The panel can be moved to the right or left on the rack as required.)
3. Tighten the four unit binding-screws ①.

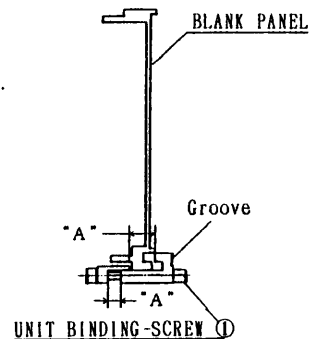

Figure 12-2

- Notes:
1. The groove indicated with the asterisk in Figure 12-2 may be used for identification marks (such as "CH1", "CH2").
 2. The above illustrations are only for the sake of explanation. Actually, the blank panel may be installed at the same time as the Load Unit(s) is installed on the rack mount frame.

13. <SPECIFICATIONS>

Item	Model	PLZ-50WU	PLZ-150WU	PLZ-300WU	Remarks
Power Requirements		90-250 V, 50/60 Hz single-phase AC, approx. 12 VA			
Load Input					
Maximum Operable Voltage		60 VDC			
Minimum Operable Voltage		2 VDC, 10A	2.2 VDC, 30A	2.2 VDC, 60A	Refer to Section 15 "Operable Range Charts".
Maximum Current		10 A	30 A	60 A	
Maximum Wattage		50 W	150 W	300 W	
Constant Current Mode					
Current Range		0 - 10 A	0 - 30 A	0 - 60 A	
Stability		±0.1% +2mA	±0.1% +3mA	±0.1% +5mA	Note 1, Note 2
Response Time		100 μs or less	150 μs or less	200 μs or less	For change of 10 - 90% of full scale
Ripple Noise		0.05% A rms of full scale			Within 5Hz - 1MHz
Constant Resistance Mode					
Resistance Range		0.2 - 10 Ω or over	0.1 - 5 Ω or over	0.05 - 2 Ω or over	
Stability		±0.1% +2mA	±0.1% +3mA	±0.1% +5mA	Note 2
Constant Voltage Mode					
Type		Shunt regulator			For remote control only
Operable Voltage Range		2 - 60 VDC	2.2 - 60VDC		

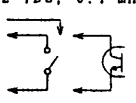

Note 1: For change within load input operable voltage

Note 2: For ±10% change of AC line voltage

Item	Model	PLZ-50WU	PLZ-150WU	PLZ300-WU	Remarks
Remote Control					
Constant Current Mode	Control of load current with voltage signal (Maximum load current with 10V signal)				Input impedance approx. 70 k Ω
Constant Voltage Mode	Control of load voltage with to voltage signal (Maximum load voltage with 10V signal)				Input impedance approx. 15 k Ω
CC/CR Select	CR mode/L	Contact signal or photo-isolated open collector			12 VDC, 0.4 mA 
Load ON/OFF Control	Load ON/L	With internal pull up circuit			Load OFF/H 12 VDC fanout approx. 0.4 mA
Protectors					
Overvoltage	Cuts out current when voltage has exceeded approx. 70 V				Alarm lamp blinks
Overcurrent	Approx. 11A	Approx. 33A	Approx. 65A		
Overpower	Approx. 55W	Approx. 160W	Approx. 330W		
Overtemperature	At approx. 90 deg.C (194 deg.F) of heat sink				
Reverse Polarity	Fuse to break the circuit				
Output Signals					
Current Monitor Signal	1 volt for maximum load current. Accuracy: $\pm 2\%$ of maximum load current				Output impedance approx. 500 Ω
Alarm Signal	When one of the protectors has tripped, the photoisolated open-collector output becomes L.				
Indicator Lamps					
POWER Lamp	Green LED (illuminates to indicate power on)				
OPERATE Lamp	Red LED (illuminates to indicate load on)				
ALARM Lamp	Red LED (illuminates to indicate protector trip)				
CURRENT Lamp	Red 7-dot bargraph (illuminates to indicate load current level)				

Item	Model	PLZ-50WU	PLZ-150WU	PLZ-300WU	Remarks
General Items					
Parallel Operation	Can be done in constant current mode with remote control				
Cooling System	Forced air cooling with fans on Rack Mount Frame RMF3-WU				
Operable Ambient Temperature and Humidity	0 to 40 deg C (32 to 104 deg F), 80% RH or lower				
Withstanding Voltage	1500 VAC, between AC input terminal and casing, for 1 minute				
Insulation Resistance	Between load input terminal and casing: > 20 MΩ, with 500 VDC Between AC input terminal and casing: > 30 MΩ, with 500 VDC				
Overall Dimensions, Including Extrusions	50W × 128H × 330D mm (1.96W × 5.04H × 13.0D in.)	100W × 128H × 330D mm (3.94W × 5.04H × 13.0D in.)	202W × 128H × 330D mm (7.95W × 5.04H × 13.0D in.)		
Weight	Approx. 1.1kg (Approx. 2.4 lbs)	Approx. 2.2kg (Approx. 4.8 lbs)	Approx. 4kg (Approx. 8.8 lbs)		
Accessories					
Instruction Manual	1 copy				
Fuse	15 A × 1	10 A × 4	75 A × 1		
Terminal Parts for load input	Load wires (3m) with molex 3191-02P... 1 sets	/			
Remote Control Cable	Cable with Molex 5264-12 ... 2 m × 1				

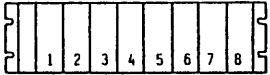
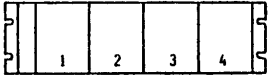
070001

Item	Model	RMF3-WU Rack Mount Frame *1	Remarks
Number of Units Accommodated		(1) 8 units of PLZ50WU *2 	
		(2) 4 units of PLZ150WU *3 	
		(3) 2 units of PLZ300WU *4 	
		(4) Combination of PLZ50WU, PLZ150WU and PLZ300WU also is possible.	
Air Cooling Unit		80-mm 24 V DC four fans	
Power Requirements		90 - 250 V, 50/60 Hz single-phase AC, approx. 25 VA	
Withstanding Voltage		1500 VAC, between AC input terminal and casing, for 1 minute	
Insulation Resistance		Between AC input terminal and casing: > 30 MΩ, with 500 VDC	
Dimensions (Frame Only)		See Figure 14-2.	
Weight (Frame Only)		Approx. 3 kg (6.6 lbs)	
Accessories			
	Instruction Manual	1 copy	Z1-737-220
	Power Cord	VM1165B-VM1172 AC Cord Set	85-10-0121
	Power Cord for Unit	Wire Kit for RMF	91-87-3748

* 1 : Can be installed on an EIA or JIS standard rack. See Section 10 for details.

* 2 : Cover up the void space with Blank Panel BP8-WU (optional).

* 3 : Cover up the void space with Blank Panel BP4-WU (optional).

* 4 : Cover up the void space with Blank Panel BP2-WU (optional).

14. <OVERALL DIMENSIONS>

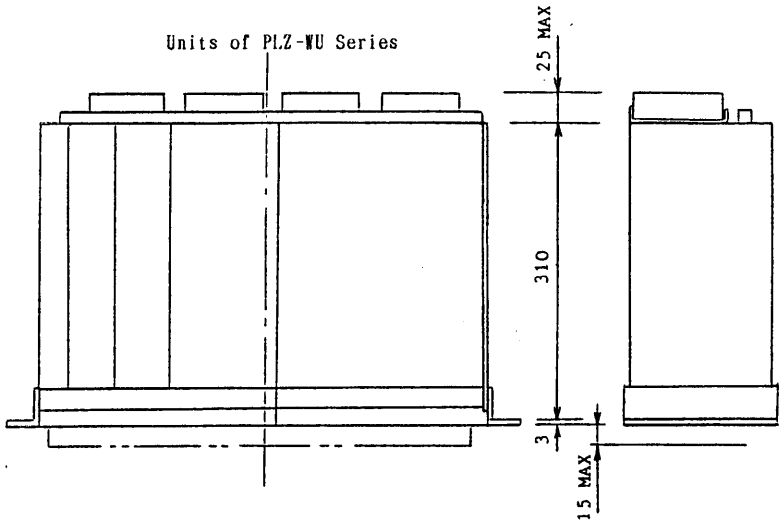

Figure 14-1

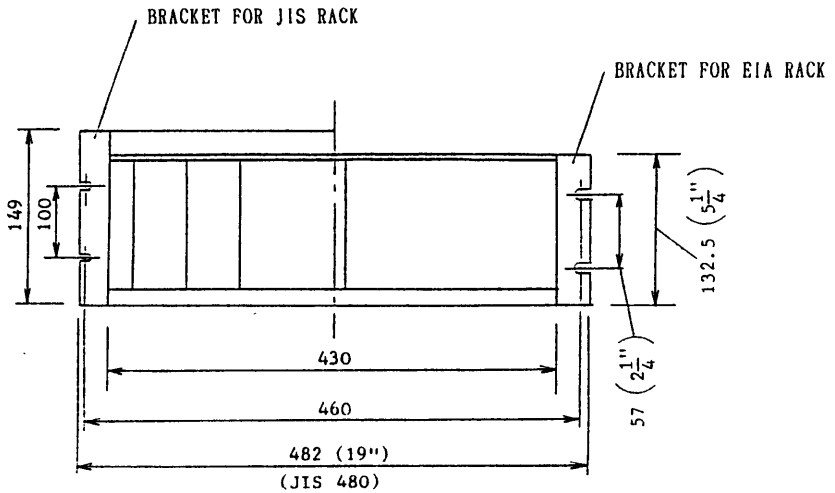

Figure 14-2

15. < OPERABLE RANGE CHARTS >

