



Multi-functional Electronic Load **PLZ-4WH Series**

Maximum operating voltage: 650V

165W, 330W, 1000W: 3 types

With connecting boosters (1000W type exclusive), maximum of 9kW/450A

Operating mode for constant current, constant resistance, constant voltage, constant power,
constant current + constant voltage, and constant resistance + constant voltage

Sequence function (up to 1024 steps)

Voltage monitor terminal for monitoring high voltage

Equipped as standard with USB 2.0, GPIB, and RS-232C



High-Voltage Electronic Load 650V

All new design with upgraded performance!

For EV and HEV high-voltage converters. With the booster, extended capacity at a low cost can be realized!

In recent years, the market trend of various devices that compose in the automotive electronics such as EV, HEV, and the new energy market for PV power generation, fuel cells, secondary batteries have been moved to higher voltage and larger capacities. At the same time, it has increased the demand for the Electronic Load evaluation equipment to meet these new requirement. The PLZ-4WH Series continues to provide excellent operability of the conventional model (PLZ-4W Series) while extending the maximum operating voltage to 650V. Furthermore, when a booster unit (PLZ2004WHB) is connected, up to 9kW/450A can be realized with less space and at a low cost. The interface, USB, GPIB, and RS-232C functions comes as standard and supports automated testing applications.

Applications EV and HEV high-voltage converter evaluation testing
PV power generation, fuel cell, secondary batteries,
and other evaluation testing High-voltage device
evaluation testing

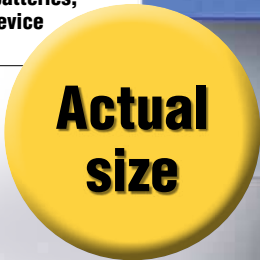

DC ELECTRONIC LOAD **NEW**

Multi-functional Electronic Load

PLZ-4WH Series

4 model

■ Product line-up

Model	Operating voltage	Current	Power
PLZ164WH	5V ~ 650V	8.25A	165W
PLZ334WH		16.5A	330W
PLZ1004WH		50A	1000W
PLZ2004WHB		100A	2000W

[Other features]

- Parallel operation function ● Communication function ● Voltage monitor output ● Current monitor output ● Adjustable slew rate ● Switching operation ● Soft start ● Elapsed time display
- Auto load-off timer ● Remote sensing ● External load on/off control input ● External range switching input ● External trigger input ● External alarm input ● Alarm status output
- Load-on status output ● Range status output ● Short signal ● External voltage control (CC, CR, CV, and CP modes) ● External resistance control (CC, CR, CV, and CP modes)
- Overvoltage protection (OVP) ● Overcurrent protection (OCP) ● Overpower protection (OPP) ● Overheat protection (OHP) ● Undervoltage protection (UVP) ● Reverse connection protection (REV)

ACCESSIBILITY

Reliable testing supported by ease of use

The front panel is the common design in all of PLZ-4W Series. Since operability is uniform, tests can be set up quickly and easily.

Operating range up to 650 V

The PLZ-4WH supports input voltages of up to 650V, and it can be used to evaluate EV and HEV in-vehicle chargers, DC/DC converters, and battery cells; evaluate power supplies for high-voltage DC electric supply systems; perform PFC tests on European and other three-phase 400V system input power supplies; and evaluate and test high-voltage parts related to such equipment. Moreover, it achieves to enlarge further operating range. (See the figure below.) It can operate from 5V, and even if the current is more than 0.5V and less than 5V, it can be used with reduced current.

- Comparison with our conventional PLZ-3WH (PLZ1003WH) model

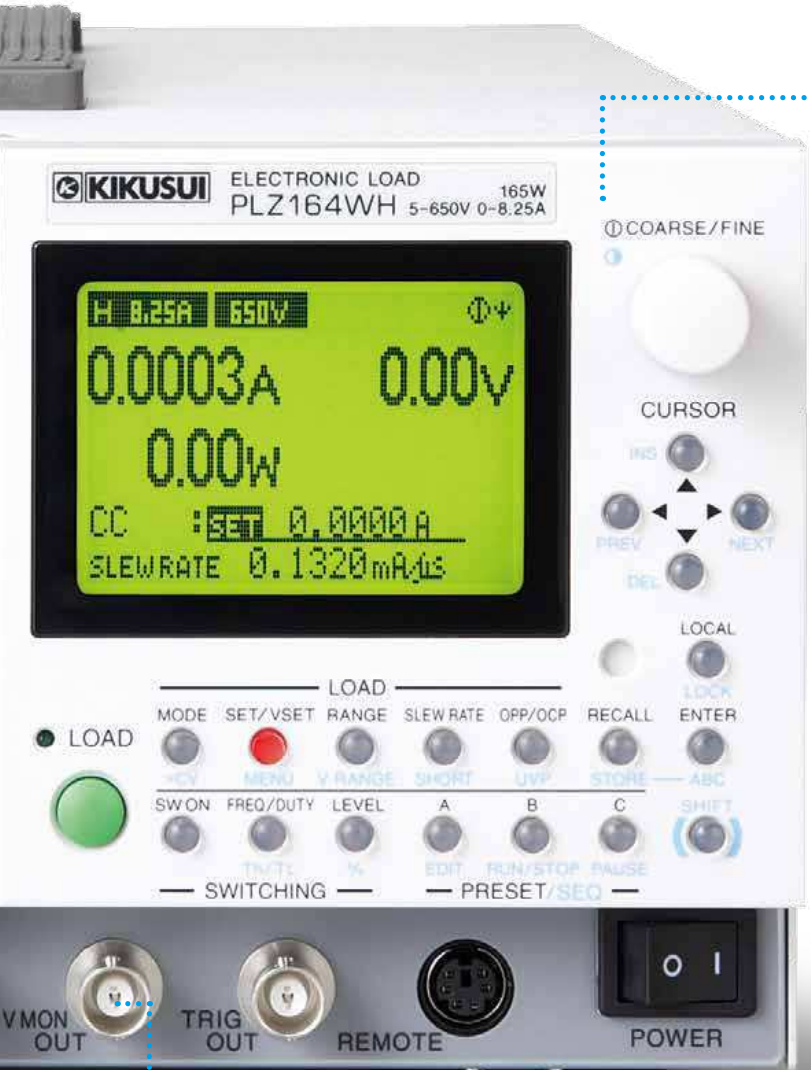
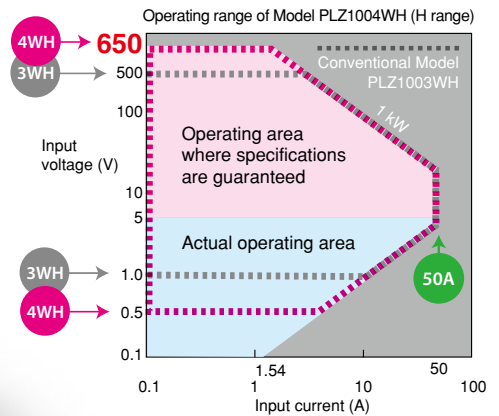

Easy measurement of voltage and current



In addition to an insulated-type current monitor terminal, an insulated-type voltage monitor terminal has been attached to the front panel. This makes it possible to measure voltage and current simply and with confidence.

When set in 650V range	100:1
When set in 65V range	10:1

Full-featured interface communication function



The unit comes equipped as standard with USB, GPIB, and RS-232C functions, so it can easily be incorporated into a variety of inspection systems.



PERFORMANCE

Achieving up to 9kW/450A with less space and low cost

By connecting the maximum of four PLZ2004WHB boosters (sold separately) to the PLZ1004WH, it is possible to use the product as an Electronic Load unit for up to 9kW/450A. Compared to parallel operation of the same model, size (space) reductions of up to about 30%, can be achieved. Incidentally, optional PC01-PLZ-4W and PC02-PLZ-4W parallel operation cables will be required for connections depend on the number of units to be connected.

boosters PLZ2004WHB



*Exclusively used for Model PLZ1004WH.
It can not be used to connect any other model.



● Example combination
3 kW system consisting of PLZ1004WH (top) and PLZ2004WHB booster (bottom)

● Parallel operating units and capacity (maximum current and power)

Slave Unit	1 Unit	2 Units	3 Units	4 Units
PLZ2004WHB	150A 3000W	250A 5000W	350A 7000W	450A 9000W

● In comparison of the conventional model for the maximum 9kW system



Conventional Model
PLZ-3WH Series
PLZ1003WHx9



Approx.
30%
of reduced
volume



NEW
PLZ-4WH Series
PLZ1004WH + PLZ2004WHBx4

Capable of parallel operation with up to five units of the same model

Parallel operation without the use of boosters is also possible up to five units of the same model, including the master unit, can be connected in parallel (5kW/250A maximum). In this case, the system operates under the master-slave configuration, and the master unit controls and displays the entire system. Note that optional PC01-PLZ-4W parallel operation cables will be required for connections depend on the number of units to be connected.

● Parallel operating units and capacity (maximum current and power)

Slave Unit	1 Unit	2 Units	3 Units	4 Units
PLZ164WH	16.5A 330W	24.75A 495W	33A 660W	41.25A 825W
PLZ334WH	33A 660W	49.5A 990W	66A 1320W	82.5A 1650W
PLZ1004WH	100A 2000W	150A 3000W	200A 4000W	250A 5000W

*The constant current mode setting accuracy and current measurement accuracy can be set to the same accuracy as that of the main unit by calibrating in parallel operation.

● Basic connection diagram

[Booster operation]

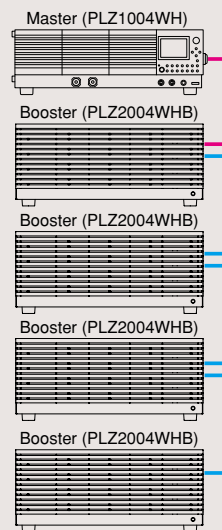

— PC02-PLZ-4W parallel cable
(for connecting main unit and booster)

[Parallel operation]

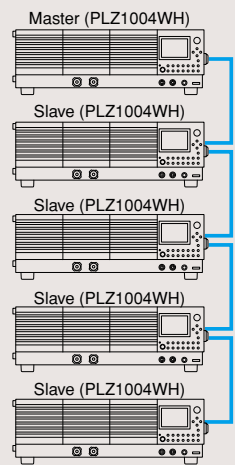

— PC01-PLZ-4W parallel cable

★ Large capacity systems (9kW and above), rack systems and so on is also able to be supported. For details, please contact us.

PERFORMANCE

Low range (1/100) feature

In CC, CR, and CP modes, three ranges are available: H, M, and L. The L range is 1/100, enabling coverage from low to high power with a single unit.

Current setting resolution

	PLZ164WH	PLZ334WH	PLZ1004WH
H	300μA	1mA	2mA
M	30μA	100μA	200μA
L	3μA	10μA	20μA

Ability to switch between a wide range of response speeds

The PLZ-4WH detects input current and voltage, and it operates by negative feedback control of those values. It secures and maintains stable operation by enabling the user to select the optimum speed of response by setting the negative feedback control response as shown below to counter operational instability that occurs in connection with the response characteristics of the test object, length of the load wiring, or size of the loop, for instance.

CC, CR modes (4 stages)

- 1/1: Normal response speed
- 1/2: Half the normal speed
- 1/5: One-fifth the normal speed
- 1/10: One-tenth the normal speed

CV mode (5 stages)

- 100: 100 times the normal speed
- 10: 10 times the normal speed
- 1/1: Normal response speed
- 1/10: One-tenth the normal speed
- 1/100: One-hundredth the normal speed

Support for six operation modes

The PLZ-4WH is equipped with six operation modes: constant current, constant resistance, constant voltage, constant power, constant current + constant voltage, and constant resistance + constant voltage modes.

Equivalent circuits and operation in each mode

Constant current mode(CC)

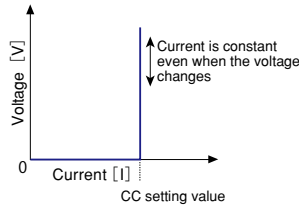
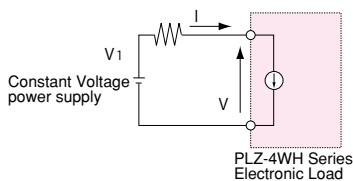

Constant power mode(CP)

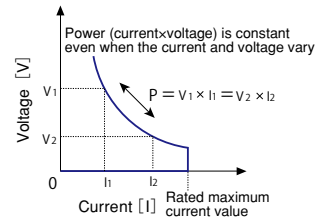
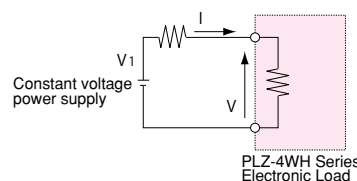

Constant resistance mode(CR)

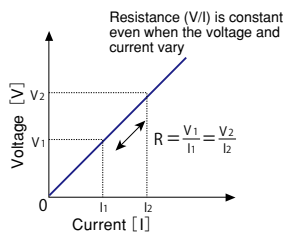
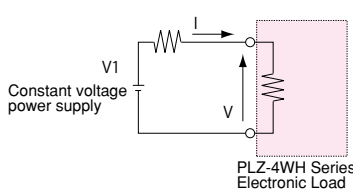

Constant current+constant voltage mode(CC+CV)

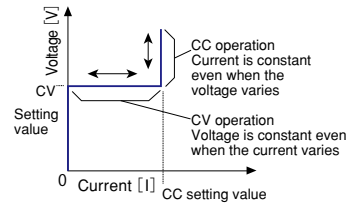
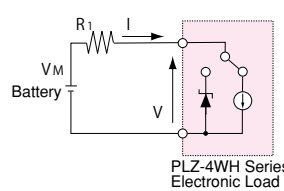

Constant voltage mode(CV)

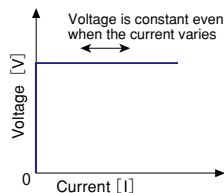
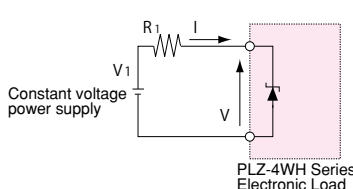

Constant resistance+constant voltage mode(CR+CV)

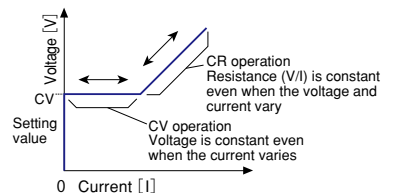
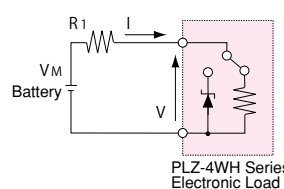

FUNCTIONS

Load-on/off operations

▶ Adopting the Load-on/off functions that flexibly apply to the system

With load-on/off operations, the following items can be selected in addition to standard operations:

- Start-up with load-on status when the power is turned on
- Display the elapsed time of the load-on period
- Load-off after a certain time has elapsed
- Load-on/off by the relay or other external signal

Remote sensing function

▶ Compensating the voltage drop of the wiring

Connecting a sensing terminal to the DUT makes it possible to set the combined resistance, including even the resistance of the wiring, from the panel in constant resistance mode. Also, points that connect the sensing function can be set to a certain power and certain voltage in constant power mode and constant voltage mode. Furthermore, since transient characteristics are improved in these constant voltage, constant power, and constant resistance modes, it also leads to operational stability. (Voltage that can be compensated: 2V one way)

Switching function

▶ Transient response test conditions are also freely changeable on the spot

In constant current mode and constant resistance mode, switching operations of up to 4kHz are possible with the built-in oscillator. Also, the level, frequency, duty cycle (ratio), and other configuration parameters can be changed even during a load-on period.

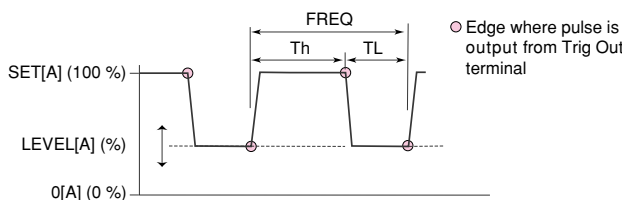

[Configuration parameters]

- Operation modes: CC and CR
- Duty cycle settings: 5% to 95%, in 0.1% steps
- Frequency setting range: 1Hz to 4kHz
- Frequency setting resolution:
 - 0.1Hz at 1Hz to 10Hz
 - 1Hz at 10Hz to 100Hz
 - 10Hz at 100Hz to 1kHz
 - 100Hz at 1kHz to 4kHz
- Frequency setting accuracy: $\pm 0.5\%$ of set
- *The minimum duration for a duty cycle is 50 μ s.

Soft start function

▶ Assures even with steep voltage application

In constant current mode, the product can prevent the generation of overcurrent* even when voltage is steeply applied from the DUT in "Load On condition and with the current having been set." For example, in a battery discharge test, it can suppress the generation of overcurrent when for some reason voltage is suddenly applied to an Electronic Load used for discharge.

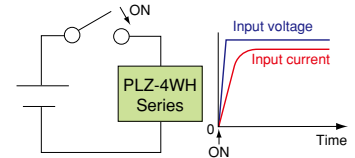

*There is electrostatic capacitance between the Electronic Load input terminals. Charging and discharging current flows to this capacitance.

▶ Ability to start the power in CC mode

In many cases during constant voltage power supply tests, testing is conducted in constant resistance mode for start-up time measurements (during start-up), and in constant current mode during load change tests. If, however, the soft start time is set to a time corresponding to the start-up time of the constant voltage power supply, it is possible to perform start-up time measurements and load change tests in constant current mode, without changing the operation mode. (Either 1, 2, 5, 10, 20, 50, 100, or 200ms can be selected as the soft start time.)

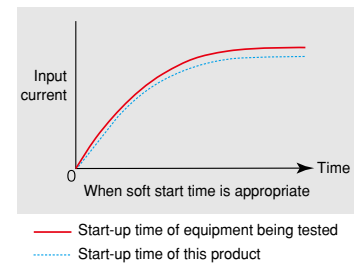

Short function

▶ Improved efficiency for the current limit evaluation with a single action

In tests such as the DC power supply "fold-back type drooping characteristics test of current limiting characteristics," the maximum current (in constant current mode) or the minimum resistance (in constant resistance mode) can be set with a single action and thus increase work efficiency. At the same time, since contact signals are output to an EXT CONT connector, it is possible to achieve even lower impedance shorting by driving exterior relays and shorting the output of the tested device.

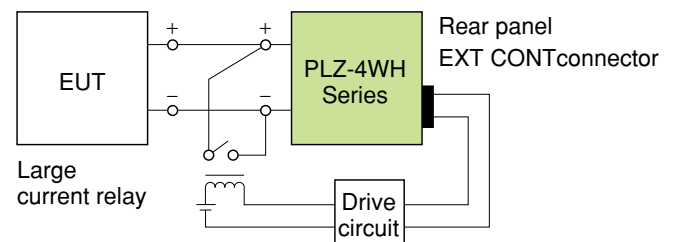

FUNCTIONS

Sequence function

▶ Actual load simulation by programming current waveforms internally

Arbitrarily set sequence patterns can be saved in the built-in memory and executed. Ten normal sequence programs and one fast sequence program can be saved. Although sequence editing and execution can be performed from the panel, those tasks can also be performed easily by using the application software separately sold "Wavy"* sequence creation software.

*A personal computer will require one of the following interfaces: USB, RS232C, or GPIB.

■ Normal sequence

The execution time and Load ON/OFF can be set for each step. The level can be changed not only in a stepped form but also in a ramped form. It is also possible to cancel pausing both by using the PAUSE function and by external trigger input, and to synchronize with trigger output and other external equipment.

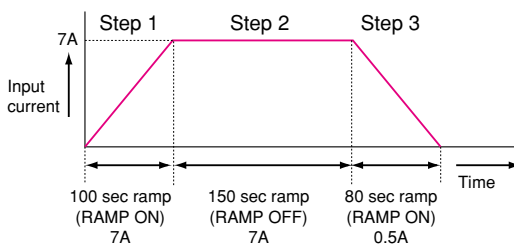

■ Fast sequence

Each step is executed at high speed. Since the time resolution is high, fast simulation is possible. The execution time, level, and trigger output can be set.

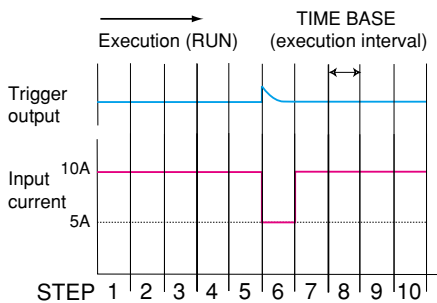

● Sequence configuration parameters

	Normal Sequence	Fast Sequence
Operation mode	CC, CR, CV, CP	CC, CR
Maximum steps	256	1024
Step execution time	1ms~999h59min	100μs~100ms
Time resolution (setting range)	1ms (1ms~1min) 100ms (1min~1h) 1s (1h~10h) 10s (10h~100h) 1min (100h~999h59min)	100μs

Elapsed time display and automatic load-off timer

▶ Convenient battery discharge function

By combining four functions, namely, the elapsed time display, undervoltage protection (UVP), load-off voltage display, and automatic load-off timer, it is possible to perform two tests that are convenient



▲ Example of load-off voltage display

for battery discharge testing, namely, the "measurement of time from discharge start to the final voltage" and "measurement from discharge start to the closed circuit voltage after a certain time has elapsed."

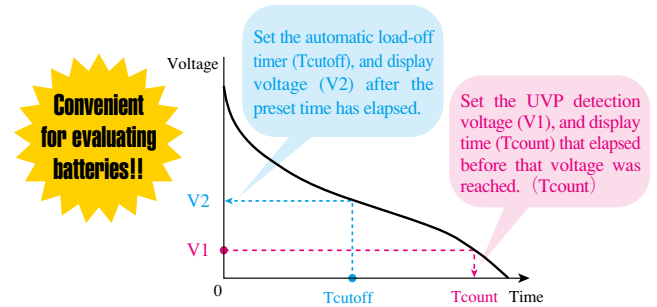

ABC preset memory

▶ Instantaneous retrieval of settings

Settings can be saved in three memories (A, B, and C) that are available for each range of each mode. Saved settings can be freely retrieved and saved even during load-on periods. In constant current + constant voltage mode and constant resistance + constant voltage mode, the memories for the constant current and constant voltage, and for the constant resistance and constant voltage, can be retrieved and saved.

Protective functions and other features

Overcurrent protection (OCP), overpower protection (OPP), overvoltage protection (OVP), undervoltage protection (UVP), overheat protection (OHP), reverse connection protection (REV), external alarm input detection, configuration setting, and setup memories (100)

APPLICATIONS

Evaluation Test on EV/HEV internal chargers and DC/DC converters

● Built-in charger characteristics test and battery simulation

By connecting a DC Electronic Load unit and high-voltage DC power supply in parallel, the PLZ-4WH is used as a simulated battery for an EV in-vehicle charger. Start-up tests and load change tests are performed in Electronic Load CV mode.

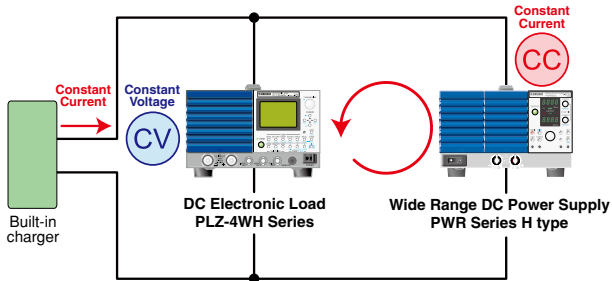

● Use as a high-speed constant-current power supply

The unit can be used as a high-speed constant-current power supply by controlling high-speed positive current at A and negative current at B. A simulation of the regenerative current of brushless motor with regards to the interactive converter is performed.

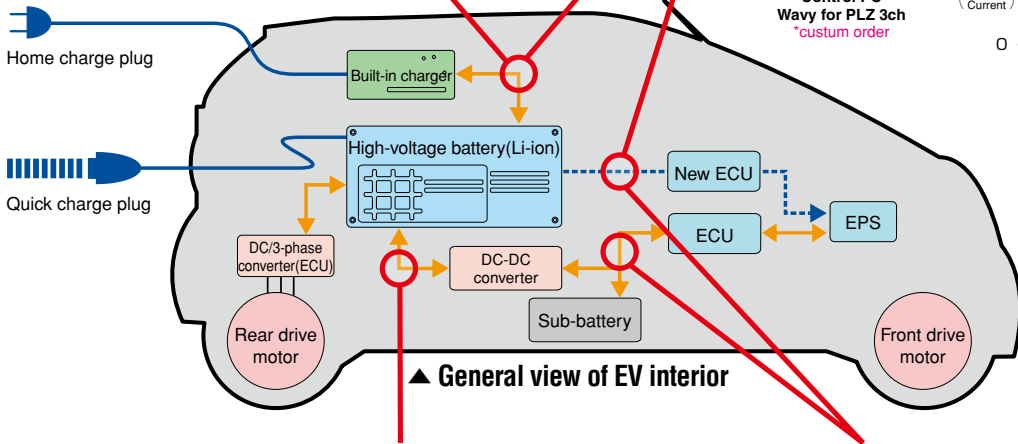
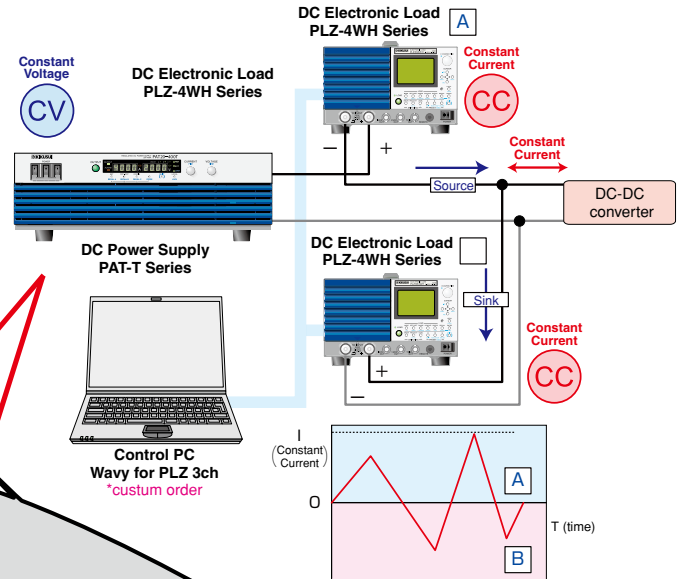

● For power supply variation tests

By connecting a DC Electronic Load unit and high-voltage DC power supply in parallel, the PLZ-4WH is used as a simulated battery to simulate medium speed power supply variations. Variation waveforms can be created and executed with Wavy sequence creation software.

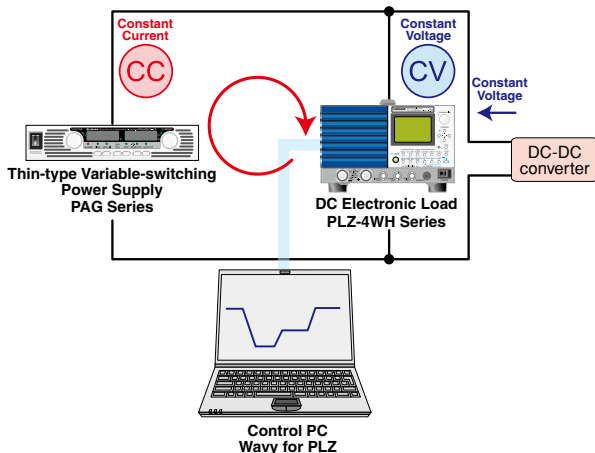

● For motor surge absorption measurement

During a brushless motor performance evaluation, the regenerative current from the brushless motor is absorbed, protecting the power supply and ECU.

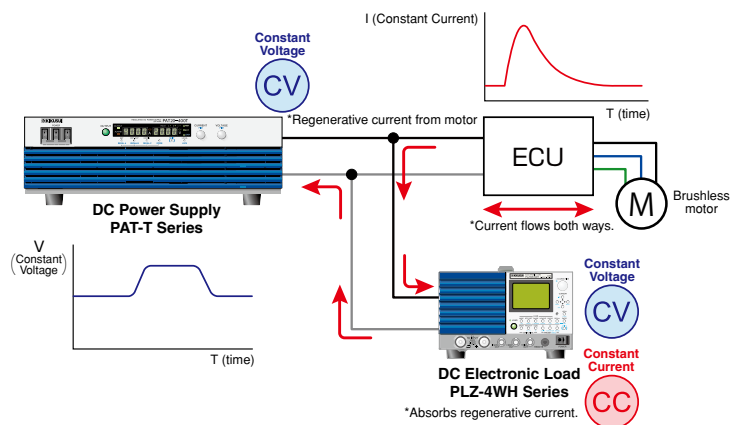

★ Select a PLZ-4W, 4WL, or 4WA Series unit according to the purpose of use. See the series lineup at the end of this catalogue.

APPLICATIONS

For evaluation test on parts

●For life performance acceleration tests

The PLZ-4WH can be used not only for temperature rise tests, long-term durability tests, pulse interrupt characteristics tests, and other high-accuracy constant current tests but also for pulse current evaluations.

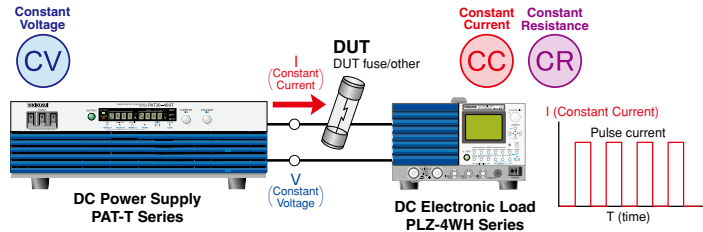

●As high-accuracy constant current power supply

By connecting a constant voltage power supply and a DC Electronic Load unit in series, the product achieves constant current at the DC Electronic Load unit's constant current accuracy.

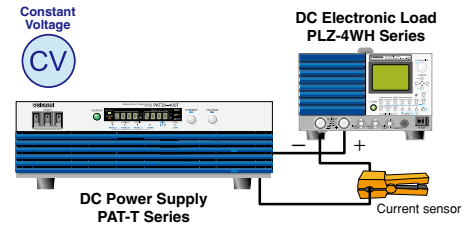

For evaluation test on secondary batteries

●For battery charge-discharge tests

The PLZ-4WH can be used to evaluate impedance and residual capacity by discharging electricity not only at a normal constant current but also at a pulse current corresponding to the actual load. Waveform patterns can be created with Wavy for PLZ, too.

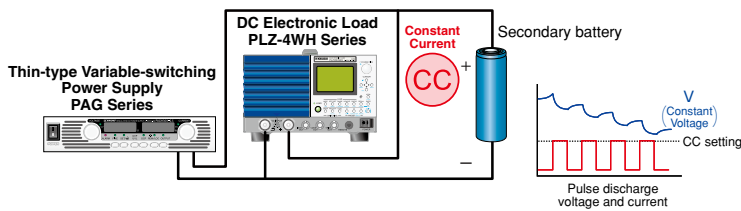

●Battery capacitor

During a secondary cell performance evaluation, it is necessary to perform a capacity test based on the battery's rating. Using the Electronic Load unit's +CV function, a capacity evaluation is performed by discharging the CV when the prescribed voltage is reached.

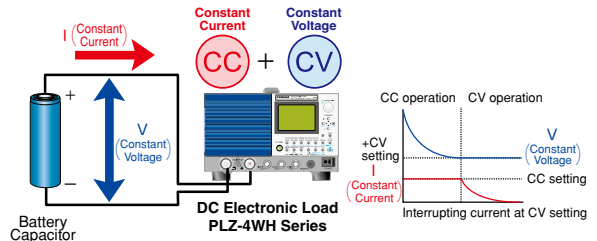

OPTION

"Wavy" sequence creation and control software

Wavy series



Download!

A Wavy trial version is available!

You can try it out for three weeks without functional limitations.
http://www.kikusui.co.jp/download/index_j.html

This is software that further enhances the waveform generation and sequence functions of the PLZ-4WH Series. Using a mouse, it is possible to create and edit with the sensation of using a spreadsheet and drawing.

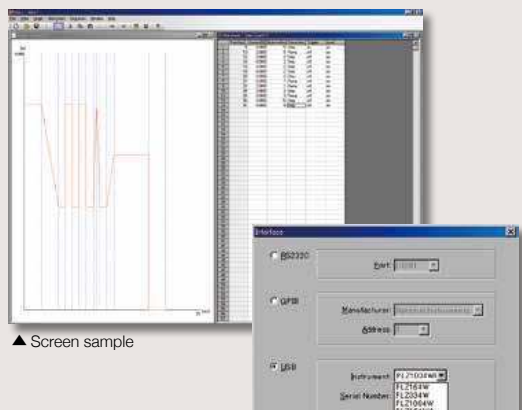

▲ Screen sample

■ Sequence creation software Wavy for PLZ-4W

Operating environment : Windows 2000 / Windows XP / Windows Vista / Windows 7
 *See our home page for details.

- Creating and editing data of test conditions required so that the sequence operation can be done easily.
- Using the save function for data files of test conditions makes routine test condition control easy.
- The progress of executed sequences is displayed by the cursor and settings on an "execution graph."
- It is possible to observe actual output intuitively, using a "monitor graph" that plots monitored values while an execution is in progress.
- Acquired monitor data can be saved as test results.
- A "waveform image" window was newly added, making it easy to see the waveforms of alternating current (AC) signals.
- Arbitrary new waveforms can be easily created and edited. Also, arbitrary waveforms that are created can be quickly written and output.
- The product supports the selection and nonselection of sequence step items. Functions such as the pause function, trigger function, and AC waveform can be selected as needed.

PLZ164WH / PLZ334WH / PLZ1004WH specifications

Ratings			
Model	PLZ164WH	PLZ334WH	PLZ1004WH
Operating voltage	5V to 650V		
Current	8.25A	16.5A	50A
Power	165W	330W	1000W
Minimum operating voltage*1	0.5V		
Load-off input resistance	2.21 [MΩ]*2		

*1 Minimum voltage when current starts to flow through the unit. Occurs at the load input terminal.
 *2 When doing parallel operation with same model: 2.21/number of units [MΩ]. When doing parallel operation with PLZ2004WHB: 2.21 [MΩ].

Constant Current (CC) mode				
Model	PLZ164WH	PLZ334WH	PLZ1004WH	
Operating range	H range	0 to 8.25A	0 to 16.5A	
	M range	0 to 825mA	0 to 1.65A	
	L range	0 to 82.5mA	0 to 165mA	
Setting range	H range	0 to 8.6625A	0 to 17.325A	
	M range	0 to 866.25mA	0 to 1.7325A	
	L range	0 to 86.625mA	0 to 173.25mA	
Resolution	H range	300 μA	1mA	
	M range	30 μA	100 μA	
	L range	3 μA	10 μA	
Setting accuracy	H, M range	± (0.2 % of set + 0.1 % of f.s.*1)		
	L range	At least 300 μA	± (0.2 % of set + 0.1 % of f.s)	
		Less than 300 μA	± (0.2 % of set + 0.1 % of f.s) + Vin*2/2.21 [MΩ]	
	Parallel operation	± (1.2 % of set + 1.1 % of f.s.*1)		
Input voltage variation*3	H, M range	20mA		
	L range	2mA		
Ripple	rms*4	2mA	4mA	
	p-p*5	20mA	40mA	
	Parallel operation (typ)	rms*4	When doing parallel operation with same model: Single unit specifications x Number of units. When doing parallel operation with PLZ2004WHB: PLZ1004WH single unit specifications x (Total power capacity/kW)	
		p-p*5		

*1 Full scale of range, with M range being full scale of H range
 *2 Vin: The voltage at the load input or sensing terminals
 *3 When the input voltage is changed from 5V to 650V at a current equal to the rated power/650V
 *4 Measurement frequency bandwidth: 10Hz to 1MHz
 *5 Measurement frequency bandwidth: 10Hz to 20MHz

Constant Resistance (CR) mode			
Model	PLZ164WH	PLZ334WH	PLZ1004WH
Operating range*1	H range	1.65S to 30 μS	3.3S to 60 μS
	M range	(606.06mΩ to 33.333kΩ)	(303.03mΩ to 16.666kΩ)
	L range	16.5mS to 0.3 μS	33mS to 0.6 μS
Setting range	H range	1.7325S to 0 S	3.465S to 0 S
	M range	(577.2mΩ to OPEN)	(288.6mS to OPEN)
	L range	17.325mS to 0 S	34.65mS to 0 S
Resolution	H range	30 μS	60 μS
	M range	3 μS	6 μS
	L range	0.3 μS	0.6 μS
Setting accuracy*2	H, M range	± (0.5 % of set*3 + 0.5 % of f.s.*4)	
	L range	± (0.5 % of set*3 + 0.5 % of f.s) + Vin*5/2.21 [MΩ]	
Parallel operation (typ)	± (1.2 % of set + 1.1 % of f.s.*4)		

*1 Conductance [S] = Input current [A] / Input voltage [V] = 1 / Resistance [Ω]
 *2 Converted value with input current; at sensing terminal
 *3 set = Vin/Rset
 *4 When M range: Full scale of H range
 *5 Vin: Rear load input terminal voltage or sensing terminal voltage

Slew rate			
Model	PLZ164WH	PLZ334WH	PLZ1004WH
Setting range*1	H range	0.132mA/μs to 0.132A/μs	0.264mA/μs to 0.264A/μs
	M range	13.2 μA/μs to 13.2mA/μs	26.4 μA/μs to 26.4mA/μs
	L range	1.32 μA/μs to 1.32mA/μs	2.64 μA/μs to 2.64mA/μs
Resolution (Setting range)	H range	50 μA (13.2 to 132 [mA/μs])	100 μA (26.4 to 264 [mA/μs])
		5 μA (1.32 to 13.2 [mA/μs])	10 μA (2.64 to 26.4 [mA/μs])
		0.5 μA (0.132 to 1.32 [mA/μs])	1 μA (0.264 to 2.64 [mA/μs])
	M range	5 μA (1.32 to 13.2 [mA/μs])	10 μA (2.64 to 26.4 [mA/μs])
		0.5 μA (0.132 to 1.32 [mA/μs])	1 μA (0.264 to 2.64 [mA/μs])
		0.05 μA (13.2 to 132 [μA/μs])	0.1 μA (26.4 to 264 [μA/μs])
L range	0.5 μA (0.132 to 1.32 [mA/μs])	1 μA (0.264 to 2.64 [mA/μs])	
	0.05 μA (13.2 to 132 [μA/μs])	0.1 μA (26.4 to 264 [μA/μs])	
	0.005 μA (1.32 to 13.2 [μA/μs])	0.01 μA (2.64 to 26.4 [μA/μs])	
Setting accuracy*2	± (10 % of set + 25 μs)		

*1 In constant current mode. In constant resistance mode, the maximum slew rate in each range is 1/10.
 *2 Time to reach 10% to 90% with respect to a 2% to 100% (or for M range a 20% to 100%) change from the rated current.

Constant Voltage (CV) mode			
Model	PLZ164WH	PLZ334WH	PLZ1004WH
Operating range	H range	5V to 650V	
	L range	5V to 65V	
Setting range	H range	0V to 682.5V	
	L range	0V to 68.25V	
Resolution	H range	20mV	
	L range	2mV	
Setting accuracy*1	± (0.2 % of set + 0.2 % of f.s)		
Parallel operation (typ)	± (0.2 % of set + 0.2 % of f.s)		
Input current fluctuation*2	65mV		

*1 At sensing terminal during remote sensing when input voltage is within operating range. Same with parallel operation, too.
 *2 With respect to change in current at 10% to 100% of rated voltage with input voltage of 5V (during remote sensing).

Constant Power (CP) mode			
Model	PLZ164WH	PLZ334WH	PLZ1004WH
Operating range	H range	16.5W to 165W	33W to 330W
	M range	1.65W to 16.5W	3.3W to 33W
	L range	0.165W to 1.65W	0.33W to 3.3W
Setting range	H range	0W to 173.25W	0W to 346.5W
	M range	0W to 17.325W	0W to 34.65W
	L range	0W to 1.7325W	0W to 3.465W
Resolution	H range	10mW	20mW
	M range	1mW	2mW
	L range	0.1mW	0.2mW
Setting accuracy	H, M range		± (3 % of f.s.*1)
	L range	At least 0.25W	± (3 % of f.s)
		Less than 0.25W	± (3 % of f.s + Vin*2/2.21 [MΩ])
	Parallel operation (TYP)	± (5 % of f.s.*1) (at 23°C ± 5°C)	

*1 When M range: Full scale of H range
 *2 Vin: Rear load input terminal voltage or sensing terminal voltage

Voltmeter			
Model	PLZ164WH	PLZ334WH	PLZ1004WH
Display	H range	0.00V to 650.00V	
	L range	0.000V to 65.000V	
Accuracy	± (0.1 % of rdng + 0.1 % of f.s)		
	Parallel operation (TYP)		

Ammeter			
Model	PLZ164WH	PLZ334WH	PLZ1004WH
Display	H, M range	0.0000A to 8.2500A	0.000A to 16.500A
	L range	0.000mA to 82.500mA	0.00mA to 165.00mA
Accuracy	± (0.2 % of rdng + 0.3 % of f.s.*1)		
	Parallel operation		

*1 When M range: Full scale of H range

Wattmeter				
Model	PLZ164WH	PLZ334WH	PLZ1004WH	
Display	H, M range	0.00W to 165.00W	0.00W to 330.00W	
	L range	Other than CP mode	0.000W to 53.625W	0.00W to 107.25W
		CP mode	0.0000W to 1.6500W	0.0000W to 3.3000W
0.000W to 10.000W				

*1 Displays the product of the voltage and current display values

Switching mode			
Model	PLZ164WH	PLZ334WH	PLZ1004WH
Operating mode	CC and CR		
Duty cycle settings	5 % to 95 %*1 0.1 % steps		
Frequency setting range	1Hz to 4kHz		
Frequency setting resolution	1Hz ~ 10Hz		0.1Hz
	10Hz ~ 100Hz		1Hz
	100Hz ~ 1kHz		10Hz
	1kHz ~ 4kHz		100Hz
Frequency setting accuracy	± (0.5 % of set)		

*1 The minimum time duration is 50 μs. From 1 to 4kHz, the maximum duty cycle is limited by it.

Soft start			
Model	PLZ164WH	PLZ334WH	PLZ1004WH
Operating mode	CC mode		
Time setting range*1	1,2,5,10,20,50,100,200ms		
Time setting accuracy	± (30 % of set + 100 μs)		
Response			
Response speed	CC/CR mode	Switchable in 4 stages (1/1, 1/2, 1/5, 1/10)	
	CV mode	Switchable in 5 stages (100, 10, 1, 1/10, 1/100)	
Remote sensing			
Voltage that can be compensated	One way	2V	
Protective functions			
Overvoltage protection (OVP)	110% of rated voltage for the range		
Overcurrent protection (OCP)	110% of 0.01 A rated current or 110% of the maximum current for each range: Load-off or limit selectable		
Overpower protection (OPP)	From 0.1% to 110% of rated power or 110% of the maximum power of each range: Load-off or limit selectable		
Overheat protection (OHP)	Load-off when heat sink temperature reaches 90°C		
Undervoltage detection (UVP)	Can set to Off, 5V to 650V		
Reverse connection protection (REV)	By fuse. Load-off when ALM occurs.		
Sequence functions			
Normal sequence	Operating modes	CC,CR,CV,CP	
	Maximum steps	256	
	Step execution time	1ms - 999h59min	
	Time resolution (setting range)	1ms(1ms to 1min)、100ms(1min to 1h)、1s(1h to 10h)、10s(10h to 100h)、1min(100h to 999h59min)	
Fast sequence	Operating mode	CC,CR	
	Maximum steps	1024	
	Step execution time	100 μs to 100ms	
	Time resolution	100 μs	
Other			
Elapsed time display	Measurement of time from load-on to load-off, On/Off capable 1 s to 999 h 59 min 59 s		
Auto load-off timer	Automatic load-off after elapse of preset time. Can set from 1 s to 999 h 59 min 59 s or to Off.		
Analog external control (EXT CONT connector)			
Load-on/off control input	Switchable logic level, pull-up to 5V at 10kΩ (CMOS level signal)		
External range switching input*1	2 bit, pull-up to 5V at 10kΩ (CMOS level signal)		
Trigger input	Clear the sequence operation pause when at least 10 μs are input for H (CMOS level signal for 5V system), pull-down to common by 100kΩ resistor		
External alarm input	Alarm operation with L, pull-up to 5V at 10kΩ (CMOS level signal)		
Alarm status output	During alarm (OVP, OCP, OPP, OHP, REV) operation and external alarm input: On, open collector (photocoupler)*2		
Load-on status output	During load-on: On, open collector (photocoupler)*2		
Range status output	2 bit, open collector (photocoupler)*2		
Short signal	Relay contact output (30Vdc/1 A)		
External voltage control input (CC, CR, CV, CP modes)	CC, CR, CV, and CP modes. 0 to 100% of rated current, voltage, and power at 0 to 10V (CC, CV, CP). Maximum to minimum resistance at 0 to 10V (CR).		
External resistance control input (CC, CR, CV, CP modes)	0 to 100% or 100 to 0% of rated current, voltage, and power at 0 to 10kΩ (CC, CV, CP). Maximum to minimum resistance or minimum to maximum resistance at 0 to 10kΩ (CR).		
External CV voltage control input	0 to 10% of rated voltage at 0 to 10V		
Current monitor output	10V f.s. (H/L range), 1V f.s. (M range), output impedance of 1kΩ		
Voltage monitor output	10V for each range f.s., output impedance of 1kΩ		
Front BNC terminal			
Trigger output	Output of pulse during sequence operation, switching operation, or GPIB GET command input		
Current monitor output	10V for full scale (H/L range), 1V for full scale (M range)		
Voltage monitor output	6.5V for full scale in each range		
Communication functions			
GPIB	IEEE std. 488.1-1987 SH1, AH1, T6, L4, SR1, RL1, PP0, DC1, DT1, C0, E1 Supports SCPI and IEEE std. 488.2-1992 specification command set.		
RS232C	D-SUB 9pin (EIA-232-D) Baud rate: 2400/4800/9600/19200 bps; Data bit: 8; Stop bit: 1/2; Parity: none; Flow control: Xon/Xoff. Supports SCPI and IEEE std. 488.2-1992 specification command set.		
USB	USB 2.0, 12 Mbps. Conforms to USBTMC-USB488 device class.		

*1 Front panel settings are only effective in the H range. *2 Photocoupler's maximum applied voltage is 30V and maximum current is 8mA.

*3 External CV voltage control input cannot be used in CP or CV mode.

General specifications			
Model	PLZ164WH	PLZ334WH	PLZ1004WH
Input voltage range / input frequency range	100 to 240Vac (90 to 250Vac) single phase, continuous: 47-63Hz		
Power consumption	80VAmax	90VAmax	160VAmax
Inrush current*1	140Amax		
Protective conductor current (when at 100V, 50Hz, typical value)	600 μA		
Operating temperature range/humidity range	0° to 40° C, 20% to 85% rh (no condensation)		
Storage temperature range/humidity range	-20° to 70° C, 90% rh or less (no condensation)		
Insulation resistance	Ground voltage	±750Vdc	
	Primary to input terminal	1000Vdc, 30MΩ or more (ambient temperature with 70% rh or less)	
	Primary to chassis	1000Vdc, 30MΩ or more (ambient temperature with 70% rh or less)	
	Input terminal to chassis	1000Vdc, 30MΩ or more (ambient temperature with 70% rh or less)	
Withstand voltage	Primary to input terminal	1500V Vac no abnormality for one minute	
	Primary to chassis	1500V Vac no abnormality for one minute	
	Input terminal to chassis	1000V Vdc no abnormality for one minute	
Dimensions (mm)	See the outline drawing.		
Weight	Approx. 7 kg (15.4 lb.)	Approx. 8kg (17.6 lb.)	Approx. 16kg (35.3 lb.)
Battery backup	Backs up configuration (setting) information		
Accessories	Power cord (2.4m length with SVT3 18AWG 3P plug) : 1pc., Load input terminal cover : 1pc., Lock plates for load input terminal cover : 2pc., Screw sets for load input terminal : 2pc., CD-R*2 : 1pc., Setup guide (Japanese/English) : 1pc., Quick reference in Japanese : 1pc., Quick reference in English : 1pc.		
Electromagnetic compatibility*3	Compatibility with these standards: Immunity IEC61326-1:2006 Class A Emission IEC61326-1:2006 Class A IEC61000-3-2:2006+A1:2009+A1:2009 IEC61000-3-3:2008		
Safety*4	Compatibility with these standards: Low Voltage Directive 2006/95/EC EN61010-1:2001		

*1 Approximately 70A with 100Vac input *2 CD-R contains application and sample, user's manual, communication interface manual, and VISA library (KI-VISA).

*3 Applies only to models that display CE marking on panel. Does not apply to specially ordered or modified items.

*4 This product is a Class 1 instrument. Be sure to ground this product's protective conductor terminal. If it is not properly grounded, safety cannot be guaranteed.

PLZ2004WHB specifications

Ratings	
Model	PLZ2004WHB
Operating voltage	5V to 650V
Current	100A
Power	2000W
Minimum operating voltage*1	0.5V
Input resistance when load-off	2.21 [MΩ]*2

*1 Minimum voltage when current starts to flow to the unit. Occurs at the load input terminal.

*2 In a condition in which the master unit (PLZ1004WH) is connected.

Constant Current (CC) mode		
Operating range	H range	0 to 100A
	M range	0 to 10A
	L range	0 to 1A
Setting range	H range	0 to 105A
	M range	0 to 10.5A
	L range	0 to 1.05A
Resolution*1	H range	10mA
	M range	1mA
	L range	0.1mA
Setting accuracy*2	H,M,L range	± (1.2 % of set + 1.1 % of f.s)*3
Ripple*2	H,M,L range	PLZ1004WH unit specifications × (Total power capacity/kW) (typ)

*1 When one PLZ2004WHB unit is connected

*2 When connected to master unit

*3 Full scale of range, with M range being full scale of H range

Constant resistance (CR), constant voltage (CV), and constant power (CP) mode setting accuracy		
CR mode	H,M,L range	± (1.2 % of set + 1.1 % of f.s)*1 (TYP)
CV mode	H,L range	± (0.2 % of set + 0.2 % of f.s) (TYP)
CP mode	H,M,L range	± (5 % of f.s)*1 23°C ± 5°C (TYP)

Measurement functions			
Voltmeter	Accuracy	H,L range	± (0.1 % of rdng + 0.1 % of f.s) (TYP)
		H,M,L range	± (1.2 % of rdng + 1.1 % of f.s)*1 (TYP)
Ammeter	Accuracy	H,L range	± (0.1 % of rdng + 0.1 % of f.s) (TYP)
		H,M,L range	± (1.2 % of rdng + 1.1 % of f.s)*1 (TYP)
Wattmeter		Displays the product of the values indicated by the voltmeter and ammeter	

*1 M range: full scale of H range

Protective functions*1	
Overheat protection (OHP)	Load-off when heat sink temperature reaches 90° C Load-off at time of detection
Reverse connection protection (REV)	Protection by fuse

*1 Other protective functions detect and operate with the PLZ1004WH.

Dimensions unit:mm(inches)

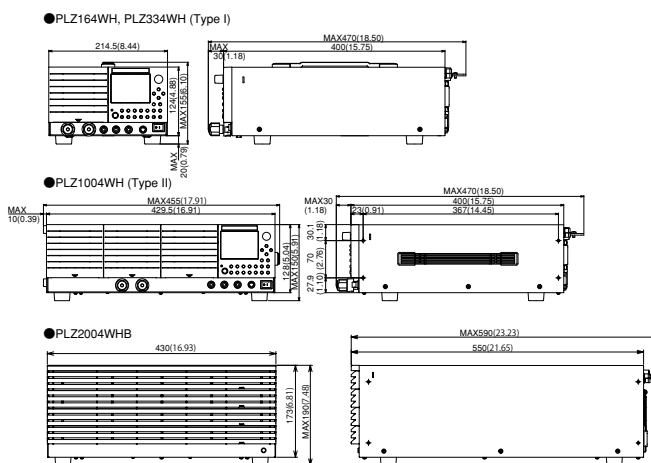

General specifications		
Model	PLZ2004WHB	
Input voltage range	100Vac to 240Vac (90Vac to 250Vac) single phase, continuous	
Input frequency range	47Hz to 63Hz	
Power consumption	200VAmx	
Inrush current*1	120Amx	
Protective conductor current	600 μA (typical: 100V, 50Hz)	
Operating temperature range	0°C to 40°C	
Operating humidity range	20% to 85% rh (no condensation)	
Storage temperature range	-20°C to 70°C	
Storage humidity range	90% rh or less (no condensation)	
Ground voltage		
± 750Vdc		
Insulation resistance	Primary to input terminal	1000Vdc, 30 MΩ or more (ambient temperature with 70% rh or less)
	Primary to chassis	1000Vdc, 30 MΩ or more (ambient temperature with 70% rh or less)
	Input terminal to chassis	1000Vdc, 30 MΩ or more (ambient temperature with 70% rh or less)
Withstand voltage	Primary to input terminal	1500V Vac, no abnormality for one minute
	Primary to chassis	1500V Vac, no abnormality for one minute
	Input terminal to chassis	1000V Vdc, no abnormality for one minute
Dimensions (mm) / weight		See the outline drawing. / Approx. 24kg (52.91 lb.)
Accessories	One power cord (2.4m length with SVT3 18AWG 3P plug), one load input terminal cover, two lock plates for load input terminal cover, two screw sets for load input terminal, and one instruction manual	
Electromagnetic compatibility*2	Compatibility with these standards:	
	Immunity IEC61326-1:2006 Class A Emission IEC61326-1:2006 Class A IEC61000-3-2:2006+A1:2009+A1:2009 IEC61000-3-3:2008	
Safety*3	Compatibility with these standards: Low Voltage Directive 2006/95/EC EN61010-1:2001	

*1 Approximately 60A with 100Vac input

*2 Applies only to models that display CE marking on panel. Does not apply to specially ordered or modified items.

*3 This product is a Class 1 instrument. Be sure to ground this product's protective conductor terminal. If it is not properly grounded, safety cannot be guaranteed.

Series Selection

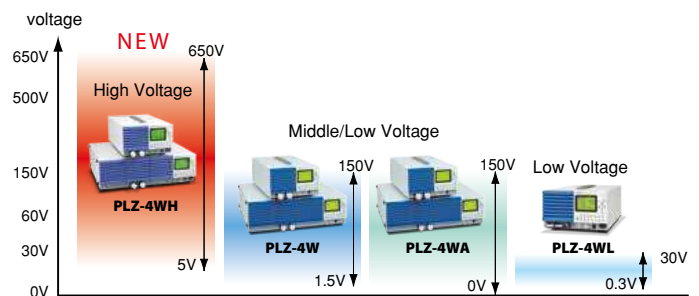

KIKUSUI ELECTRONICS CORPORATION

1-1-3, Higashiyamata, Tsuzuki-ku, Yokohama, 224-0023, Japan
Phone: (+81) 45-593-7570, Facsimile: (+81) 45-593-7571, www.kikusui.co.jp

KIKUSUI AMERICA, INC. 1-877-876-2807 www.kikusuiamerica.com

2975 Bowers Avenue, Suite 307, Santa Clara, CA 95051
Phone: 408-980-9433 Facsimile: 408-980-9409

KIKUSUI TRADING (SHANGHAI) Co., Ltd. www.kikusui.cn

Room 216, Building 4, No.641, Tianshan Road, Shanghai City, China
Phone: 021-5887-9067 Facsimile: 021-5887-9069

For our local sales distributors and representatives, please refer to "sales network" of our website.

Distributor/Representative

■ All products contained in this catalogue are equipment and devices that are premised on use under the supervision of qualified personnel, and are not designed or produced for home-use or use by general consumers. ■ Specifications, design and so forth are subject to change without prior notice to improve the quality. ■ Product names and prices are subject to change and production may be discontinued when necessary. ■ Product names, company names and brand names contained in this catalogue represent the respective registered trade name or trade mark. ■ Colors, textures and so forth of photographs shown in this catalogue may differ from actual products due to a limited fidelity in printing. ■ Although every effort has been made to provide the information as accurate as possible for this catalogue, certain details have unavoidably been omitted due to limitations in space. ■ If you find any misprints or errors in this catalogue, it would be appreciated if you would inform us. ■ Please contact our distributors to confirm specifications, price, accessories or anything that may be unclear when placing an order or concluding a purchasing agreement.

Issue:Jun.2011 2011062KSOHEC21a

*Sink High Power.
Here is a Turnkey Solution.*



PLZ-4W SR/LP SERIES

PLZ5004W SR	PLZ9004W LP
PLZ7004W SR	PLZ11004W LP
PLZ9004W SR	PLZ13004W LP

Large
Current
Maximum
2600 A
5 kW to
13 kW

Large - Capacity DC
Electronic Load System

PLZ-4W, 4WH SR/LP SERIES

* Definition of Series Name: SR (Smart Rack), LP (Load Pack)



PLZ-4WH SR/LP SERIES

PLZ5004WH SR	PLZ9004WH LP
PLZ7004WH SR	PLZ11004WH LP
PLZ9004WH SR	PLZ13004WH LP

High
Voltage
Maximum
650 V
5 kW to
13 kW

Large-Capacity DC Electronic Load System

PLZ-4W SR/LP Series

● The PLZ-4W SR/LP Series offers wide range of the "Large-Capacity DC Electronic Load System" that consists of the conventional electronic load model PLZ1004W and PLZ2004WB applying to the large current (maximum 2600 A) installed in the exclusive rack mount system.

PLZ-4WH SR/LP Series

● The PLZ-4WH SR/LP Series offers wide range of the "Large-Capacity DC Electronic Load System" that consists of the conventional electronic load model PLZ1004WH and PLZ2004WHB applying to the high voltage (maximum 650 V) installed in the exclusive rack mount system.

High Voltage
Maximum
650 V
5 kW to 13 kW



PLZ-4WH LP Series

PLZ-4WH SR Series

Applications (example)
 ●Charge/Discharge test on the large capacity secondary battery ●Converter evaluation
 ●Alternator evaluation ●FC stack cell evaluation ●PV panel evaluation ●EV charger evaluation ●Heat generation evaluation by the harness electric conduction ●Capacitor endurance test ●Evaluation on the industrial large capacity DC power supply system

Large Current
Maximum
2600 A
5 kW to 13 kW



PLZ-4W SR Series

PLZ-4W LP Series

- The system offers from 5 kW to 13 kW with two types of rack system (SR/LP type), 12 models are available.
- Assembled with exclusive components based on optimization design concept. Delivers the system with fully assembled and tested, so immediate operation is possible.
- The industry's smallest in its class for the multi-functional high-speed response DC electronic load.
- Expandable by installing additional booster units after purchase*.
*For the installation, adjustment, please contact your nearest distributor.
- AC Input 90 to 250 Vac Auto select, less than 15 A. No special wiring is required.
- Range switching function allows to guarantee the specifications even for the smaller capacity input. (Performance test Data is included with the system as standard document)
- Equipped USB/RS232C/GPIB interface as standard features.
- Capable of operation using the Sequence Creation software "Wavy".
- The Load input terminal is designed on the Safety-Comes-First concept. (protection against electric shocks)
- Load cable for large current is available as option.
(50 A/100 A/200 A/500 A/1000 A, 3 m, the cable equipped with solderless terminals on both ends)
- The base hold angle for fixing the anchor bolt (OP03-KRC) is available as a rack mount option.

■ Rear Panel (DC INPUT)

PLZ-4W SR/LP Series



SR Series



LP Series

Input terminals applying to the large current

Input terminals applying to the high voltage

PLZ-4WH SR/LP Series



SR Series









LP Series







Equipped with the boxed type of safety cover on all models

Maximizing the Safe and Secure design of the load input terminal based on the safety features (protecting from electric shocks), but also from usability perspectives such as an easy-to-connect operation by opening the terminal cover, and capable of visual check.

■ PLZ-4W SR/LP Series Lineup Operating voltage : 1.5 V to 150 V

Maximum input rating	5 kW	7 kW	9 kW	9 kW	11 kW	13 kW
	1000 A	1400 A	1800 A	1800 A	2200 A	2600 A
	PLZ-4W Smart Rack			PLZ-4W Load Rack		
	 PLZ5004W SR	 PLZ7004W SR	 PLZ9004W SR	 PLZ9004W LP	 PLZ9004W LP	 PLZ13004W LP

■ PLZ-4WH SR/LP Series Lineup Operating voltage : 5 V to 650 V

Maximum input rating	5 kW	7 kW	9 kW	9 kW	11 kW	13 kW
	250 A	350 A	450 A	450 A	550 A	650 A
	PLZ-4WH Smart Rack			PLZ-4WH Load Rack		
	 PLZ5004WH SR	 PLZ7004WH SR	 PLZ9004WH SR	 PLZ9004WH LP	 PLZ9004WH LP	 PLZ13004WH LP

OPTION

■ High Current Load Wire *Solderless terminals on both ends.

Model	DC14-2P3M-M12M8	DC38-2P3M-M12M8	DC80-2P3M-M12M8	DC80-2P3M-M12M12	DC150-2P3M-M12M12	DC150-4P3M-M12M12	DC600-2P3M-M12M12
Maximum Allowable voltage	650 V						150 V
Maximum Allowable current	50 A	100 A	200 A	200 A	300 A	500 A	1000 A
Terminal	M12/M8	M12/M8	M12/M8	M12/M12	M12/M12	M12/M12	M12/M12
Nominal Cross-Sectional Area	14 mm ² (Equivalent of AWG 5)	38 mm ² (Equivalent of AWG 1)	80 mm ² (Equivalent of AWG 3/0)	80 mm ² (Equivalent of AWG 3/0)	150 mm ² (Equivalent of AWG 6/0)	150 mm ² (Equivalent of AWG 6/0)	600 mm ²
Length / Weight *Per cable	Approx.3 m / Approx.1 kg	Approx.3 m / Approx.2.7 kg	Approx.3 m / Approx.5.6 kg	Approx.3 m / Approx.5.6 kg	Approx.3 m / Approx.10 kg	Approx.3 m / Approx.20 kg	Approx.3 m / Approx.40 kg
Exterior design	A TYPE (2 pc)	A TYPE (2 pc)	A TYPE (2 pc)	A TYPE (2 pc)	A TYPE (2 pc)	A TYPE (4 pc)	B TYPE (2 pc)
							

Sequence creation software

Wavy series 

■ Sequence creation software **Wavy for the PLZ-4W**

[Operating environment]
Windows 2000/Windows XP/Windows Vista/Windows 7
*For details, please refer to our web site.

The software that further enhances the waveform generation and sequence functions.
Using a mouse, you can create and edit feel like drawing and filling out the spreadsheet.

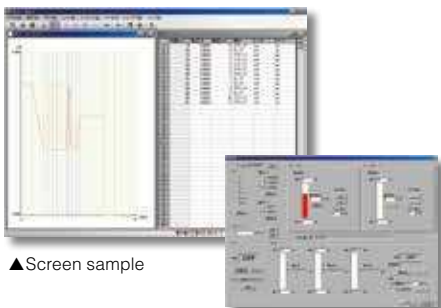

▲Screen sample

- Creating and editing data of test conditions required so that the sequence operation can be done easily.
- Using the save function for data files of test conditions makes routine test condition control easy.
- The progress of executed sequences is displayed by the cursor and settings on an "execution graph."
- It is possible to observe actual output intuitively, using a "monitor graph" that plots monitored values while an execution is in progress.
- Acquired monitor data can be saved as test results.
- A "waveform image" window was newly added, making it easy to see the waveforms of alternating current (AC) signals.
- Arbitrary new waveforms can be easily created and edited. Also, arbitrary waveforms that are created can be quickly written and output.
- The product supports the selection and nonselection of sequence step items. Functions such as the pause function, trigger function, and AC waveform can be selected as needed.

Download !

Trial version is available on our web !!
<http://www.kikusui.co.jp/en/download/index.html>

■ PLZ-4W SR Series

Specifications	Rating			Constant current mode (CC)				Constant voltage mode (CV)			
	Operating voltage	Current	Power	Operating range			Ripple	Operating range		Resolution	
	V	A	W	H range (A)	M range (A)	L range (A)	mArms *1	H range (V)	L range (V)	H range (mV)	L range (mV)
PLZ5004W SR	1.5 to 150	1000	5000	0 to 1100	0 to 110	0 to 11	100	0 to 157.5	0 to 15.75	10	1
PLZ7004W SR		1400	7000	0 to 1540	0 to 154	0 to 15.4	140				
PLZ9004W SR		1800	9000	0 to 1980	0 to 198	0 to 19.8	180				

Specifications	Constant resistance mode (CR)			Constant power mode (CP)			Weight	Power consumption
	Operating range			Operating range			Approx.	Approx.
	H range (s)	M range (s)	L range (s)	H range (W)	M range (W)	L range (W)	kg	VA
PLZ5004W SR	699.0 to 0	69.90 to 0	6.990 to 0	0 to 5250	0 to 525	0 to 52.5	110	560
PLZ7004W SR	980.0 to 0	98.00 to 0	9.800 to 0	0 to 7350	0 to 735	0 to 73.5	140	760
PLZ9004W SR	1260.0 to 0	126.0 to 0	12.60 to 0	0 to 9450	0 to 945	0 to 94.5	170	960

■ PLZ-4W LP Series

Specifications	Rating			Constant current mode (CC)				Constant voltage mode (CV)			
	Operating voltage	Current	Power	Operating range			Ripple	Operating range		Resolution	
	V	A	W	H range (A)	M range (A)	L range (A)	mArms *1	H range (V)	L range (V)	H range (mV)	L range (mV)
PLZ9004W LP	1.5 to 150	1800	9000	0 to 1980	0 to 198	0 to 19.8	180	0 to 157.5	0 to 15.75	10	1
PLZ11004W LP		2200	11000	0 to 2420	0 to 242	0 to 24.2	220				
PLZ13004W LP		2600	13000	0 to 2860	0 to 286	0 to 28.6	260				

Specifications	Constant resistance mode (CR)			Constant power mode (CP)			Weight	Power consumption
	Operating range			Operating range			Approx.	Approx.
	H range (s)	M range (s)	L range (s)	H range (W)	M range (W)	L range (W)	kg	VA
PLZ9004W LP	1260.0 to 0	126.0 to 0	12.60 to 0	0 to 9450	0 to 945	0 to 94.5	250	960
PLZ11004W LP	1540.0 to 0	154.0 to 0	15.40 to 0	0 to 11550	0 to 1155	0 to 115.5	275	1160
PLZ13004W LP	1820.0 to 0	182.0 to 0	18.20 to 0	0 to 13650	0 to 1365	0 to 136.5	300	1360

■ PLZ-4WH SR Series

Specifications	Rating			Constant current mode (CC)				Constant voltage mode (CV)			
	Operating range	Current	Power	Operating range			Ripple	Operating range		Resolution	
	V	A	W	H range (A)	M range (A)	L range (A)	mArms *1	H range (V)	L range (V)	H range (mV)	L range (mV)
PLZ5004WH SR	5 to 650	250	5000	0 to 262.5	0 to 26.25	0 to 2.625	60	0 to 682.5	0 to 68.25	20	2
PLZ7004WH SR		350	7000	0 to 367.5	0 to 36.75	0 to 3.675	84				
PLZ9004WH SR		450	9000	0 to 472.5	0 to 47.25	0 to 4.725	108				

Specifications	Constant resistance mode (CR)			Constant power mode (CP)			Weight	Power consumption
	Operating range			Operating range			Approx.	Approx.
	H range (s)	M range (s)	L range (s)	H range (W)	M range (W)	L range (W)	kg	VA
PLZ5004WH SR	52.5 to 0	5.25 to 0	525 m to 0	0 to 5250	0 to 525	0 to 52.5	110	560
PLZ7004WH SR	73.5 to 0	7.35 to 0	735 m to 0	0 to 7350	0 to 735	0 to 73.5	140	760
PLZ9004WH SR	94.5 to 0	9.45 to 0	945 m to 0	0 to 9450	0 to 945	0 to 94.5	170	960

■ PLZ-4WH LP Series

Specifications	Rating			Constant current mode (CC)				Constant voltage mode (CV)			
	Operating voltage	Current	Power	Operating range			Ripple	Operating range		Resolution	
	V	A	W	H range (A)	M range (A)	L range (A)	mArms *1	H range (V)	L range (V)	H range (mV)	L range (mV)
PLZ9004WH LP	5 to 650	450	9000	0 to 472.5	0 to 47.25	0 to 4.725	108	0 to 682.5	0 to 68.25	20	2
PLZ11004WH LP		550	11000	0 to 577.5	0 to 57.75	0 to 5.775	140				
PLZ13004WH LP		650	13000	0 to 682.5	0 to 68.25	0 to 6.825	156				

Specifications	Constant resistance mode (CR)			Constant power mode (CP)			Weight	Power consumption
	Operating range			Operating range			Approx.	Approx.
	H range (s)	M range (s)	L range (s)	H range (W)	M range (W)	L range (W)	kg	VA
PLZ9004WH LP	94.5 to 0	9.45 to 0	945 m to 0	0 to 9450	0 to 945	0 to 94.5	235	960
PLZ11004WH LP	115.5 to 0	11.55 to 0	1.155 to 0	0 to 11550	0 to 1155	0 to 115.5	260	1160
PLZ13004WH LP	136.5 to 0	13.65 to 0	1.365 to 0	0 to 13650	0 to 1365	0 to 136.5	285	1360

*1 Measurement frequency bandwidth: 10 Hz to 20 MHz At measurement current of 100 A

■ Dimensions (mm)

PLZ5004W SR	432.6 W (545) × 469.6 H (570) × 764.7 D (955)
PLZ7004W SR	432.6 W (545) × 602.3 H (705) × 764.7 D (955)
PLZ9004W SR	432.6 W (545) × 735 H (835) × 764.7 D (955)
PLZ9004W LP	570 W × 1350 H (1435) × 950 D (1020)
PLZ11004W LP	
PLZ13004W LP	
PLZ5004WH SR	432.6 W (545) × 559.6 H (660) × 764.7 D (955)
PLZ7004WH SR	432.6 W (545) × 737.3 H (840) × 764.7 D (955)
PLZ9004WH SR	432.6 W (545) × 915 H (1015) × 764.7 D (955)
PLZ9004WH LP	570 W × 1350 H (1435) × 950 D (1020)
PLZ11004WH LP	
PLZ13004WH LP	
PLZ13004WH LP	

■ Common Specifications

Input voltage range 100 V AC to 240 V AC (90 V AC to 250 V AC),
single phase, continuous
Input frequency range 47 Hz to 63 Hz
Operating temperature range 0 to 40
Operating humidity range 20 %rh to 85 %rh (without condensation)
Storage temperature range -25 to 70
Storage humidity range 90 %rh or less (without condensation)

For details of the Large-Capacity DC
Electronic Load System PLZ4W SR/LP
Series, please refer to our web site.



www.kikusui.co.jp

■ All products contained in this catalogue are equipment and devices that are premised on use under the supervision of qualified personnel, and are not designed or produced for home-use or use by general consumers. ■ Specifications, design and so forth are subject to change without prior notice to improve the quality. ■ Product names and prices are subject to change and production may be discontinued when necessary. ■ Product names, company names and brand names contained in this catalogue represent the respective registered trade name or trade mark. ■ Colors, textures and so forth of photographs shown in this catalogue may differ from actual products due to a limited fidelity in printing. ■ Although every effort has been made to provide the information as accurate as possible for this catalogue, certain details have unavoidably been omitted due to limitations in space. ■ If you find any misprints or errors in this catalogue, it would be appreciated if you would inform us. ■ Please contact our distributors to confirm specifications, price, accessories or anything that may be unclear when placing an order or concluding a purchasing agreement.

KIKUSUI ELECTRONICS CORPORATION www.kikusui.co.jp



1-1-3, Higashiyamata, Tsuzuki-ku, Yokohama, 224-0023, Japan
Phone : (+81)45-593-7570, Facsimile : (+81)45-593-7571

KIKUSUI AMERICA, INC. 1-877-876-2807 www.kikusuiamerica.com



2975 Bowers Avenue, Suite 307, Santa Clara, CA 95051
Phone : 408-980-9433 Facsimile : 408-980-9409

Printed in Japan

Issue: Feb. 2014 2014021KPRIEC21