

INSTRUCTION MANUAL
FOR
REGULATED DC POWER SUPPLY
MODEL PAR 80A
MODEL PAR 160A

KIKUSUI ELECTRONICS CORPORATION

853566

Power Requirements of this Product

Power requirements of this product have been changed and the relevant sections of the Operation Manual should be revised accordingly.

(Revision should be applied to items indicated by a check mark)

Input voltage

The input voltage of this product is _____ VAC,
and the voltage range is _____ to _____ VAC. Use the product within this range only.

Input fuse

The rating of this product's input fuse is _____ A, _____ VAC, and _____.

WARNING

- To avoid electrical shock, always disconnect the AC power cable or turn off the switch on the switchboard before attempting to check or replace the fuse.
- Use a fuse element having a shape, rating, and characteristics suitable for this product. The use of a fuse with a different rating or one that short circuits the fuse holder may result in fire, electric shock, or irreparable damage.

AC power cable

The product is provided with AC power cables described below. If the cable has no power plug, attach a power plug or crimp-style terminals to the cable in accordance with the wire colors specified in the drawing.

WARNING

- The attachment of a power plug or crimp-style terminals must be carried out by qualified personnel.

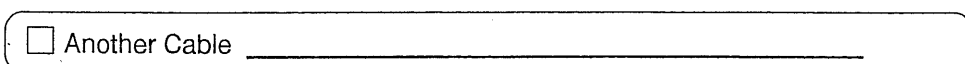
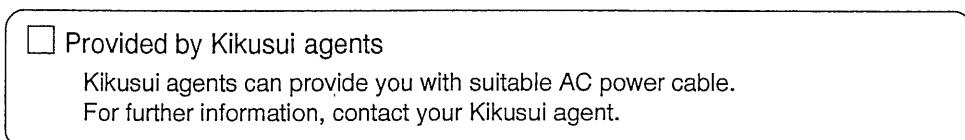
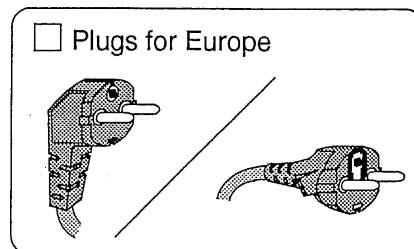
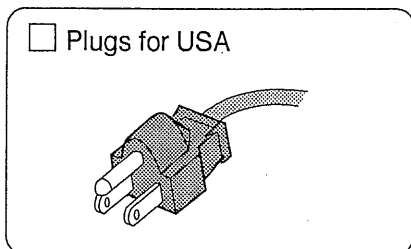
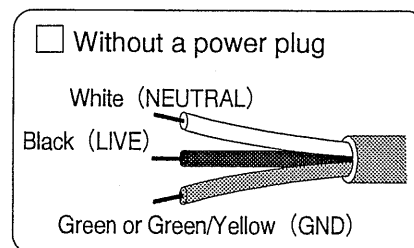
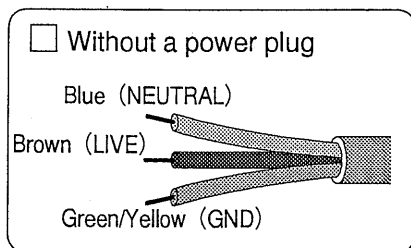

TABLE OF CONTENTS

	<u>PAGE</u>
1. GENERAL	1
1.1 Description	1
1.2 Specifications	2
2. OPERATING INSTRUCTIONS	9
2.1 General Precautions	9
2.2 Panel Features and Operation	11
2.3 Operation Method	18
2.3.1 Output Ranges of PAR 80A and PAR 160A	18
2.3.2 Constant-voltage Operation	19
2.3.3 Remote Sensing Operation	20
2.3.4 Constant-current Operation	21
2.3.5 To Use the OVP Function	22
2.3.6 External Voltage Measurement	23
2.3.7 Rack Mount	24
2.3.8 Control Board (OPTION)	25
3. MAINTENANCE	27
3.1 Cleaning	27
3.2 Calibration	28

24/11/14

053580

1. GENERAL

1.1 Description

The PAR Regulated DC Power Supply is designed primarily for test, research, and other laboratory use. Some of its outstanding features are as follows:

(1) Multiple output ranges

The PAR employs a multiple output range system and is able to cover various output ranges which would require several units of regular fixed-range power supplies.

(2) Digital displays

Both output voltmeter and ammeter are digital. The voltmeter is 4-1/2 digits and the ammeter is 3-1/2 digits. The voltmeter can be used to measure an external voltage also.

(3) Low noise and low ripple

The PAR employs a series regulator system for reduced noise and ripple.

(4) Control board (*1)

A control board is available for remote control of operation modes, such as series/parallel operation.

*1: This board is optional and may have been or may not have been ordered for your PAR.

1.2 Specifications

<u>Item</u>	<u>PAR 80A</u>	<u>PAR 160A</u>
Input		
Line Voltage *1 (standard setting):	100 V $\pm 10\%$, 50/60 Hz single-phase AC	
Input power Cord and Plug *1 (standard setting):	125 V, 12 A, parallel-wire cord, 2.5 meters long	
Current Drain (at 100 V AC):	3.3 A	4.5 A
Output		
Output Ranges:	4 ranges	3 ranges
	0 - 8 V, 0 - 10 A	0 - 16 V, 0 - 10 A
	0 - 16 V, 0 - 5 A	0 - 35 V, 0 - 5 A
	0 - 35 V, 0 - 2.5 A	0 - 80 V, 0 - 2 A
	0 - 80 V, 0 - 1 A	
Voltage Controls:	10-turn potentiometer + 1-turn potentiometer	
Voltage Resolution:	Approx. 1 mV	
Current Control:	10-turn potentiometer	
Current Resolution:	Approx. 2 mA	
Constant-voltage Performance		
Regulation *2		
Line Regulation (against $\pm 10\%$ change of line voltage):	2 mV	2 mV

*1: The PAR can be modified for other line voltage. The modification requires to change the power codes, plugs and fuses. For details, please consult your Kikusui agent.

*2: As measured at the sensing terminals.

<u>Item</u>	<u>PAR 80A</u>	<u>PAR 160A</u>
Load Regulation (against 0 - 100% change of output current, for each range):	2 mV	3 mV
Ripple and Noise (rms value, 5 Hz - 1 MHz)	300 μ V	300 μ V
Transient Response *3 (for each range)	50 μ S	50 μ S
Stability Against Tempera- ture Change *4 (typical)	50 ppm/ $^{\circ}$ C	50 ppm/ $^{\circ}$ C
Constant-current Performance		
Regulation		
Line Regulation (against \pm 10% change of line voltage):	2 mA	2 mA
Voltage Regulation (against 0 - 100% change of output voltage, for each range):	2 mA	2 mA
Ripple and Noise (rms value, 5 Hz - 1 MHz):	2 mA	2 mA
Stability Against Tempera- ture Change *4 (typical)	50 ppm/ $^{\circ}$ C	50 ppm/ $^{\circ}$ C
Cooling System		
Type:	Automatic fan start (hot start and latch)	
Fan Start Temperature (heat sink):	60 $^{\circ}$ C (140 $^{\circ}$ F)	
Fan Start Current (output current):	1A	

*3: Time required by the output voltage for recovering into within
0.05% + 10 mV of the steady state output voltage.

*4: After a warm-up period of 20 minutes or more.

<u>Item</u>	<u>PAR 80A</u>	<u>PAR 160A</u>
Output Polarity:	Positive or negative ground	
Withstanding Voltage (with respect to ground):	±250 V DC	
Insulation Resistance		
Between Input and Chassis:	≥30 MΩ, with 500 V DC	
Between Output Terminal and Chassis:	≥20 MΩ, with 500 V DC	
Ambient Temperature and Humidity:	0 - 40°C (0 - 104°F), 10 - 90% RH	
Input Fuse		
Rating *5:	4 A (slow blow)	7A (slow blow)
Dimensions:	6.4 mm dia., 32 mm long	
Output Fuses		
Rating:	6 A × 2	
Dimensions:	5.2 mm dia., 20 mm long	
Overall Dimensions:	Refer to the overall dimension drawings.	
Weight:	Approx. 9.2 kg (20.3 lbs)	Approx. 11.5 kg (25.4 lbs)
Input Power Cord *5:	Parallel-wire cord, 2.5 m long, with plug, 125 V, 12 A	
Accessories (within packing)		
Instruction manual	1 copy	
Input fuse (6.4 mm dia., 32 mm long)	4 A (SB) × 1	7A (SB) × 1
GND terminal	1	
Banana plugs for external voltage measurement	2	

*5: When line voltage setting is for 100 V AC.

<u>Item</u>	<u>PAR 80A</u>	<u>PAR 160A</u>
(Options)		
(Control board)		(APO-R1)
(Mounting brackets)		(B24) (B11)
Functions		
OUTPUT switch:		ON/OFF control of output
Output voltage when OFF		0 to -0.4 V
SELECT switch:		To select items to be indicated by meters
LIMIT (amber lamp):		To indicate limit setting of output voltage and current converted into reference units
OVP (amber lamp):		To indicate overvoltage setting
EXT (amber lamp):		To indicate external voltage
CV (green lamp):		To indicate constant-voltage mode
CC (red lamp):		To indicate constant-current mode
UNREG (amber lamp):		To indicate that output range limit is exceeded
CONTROL *6		
CV (LOC/REM/SLV):		To select output voltage control mode for local/remote/slave
CC (LOC/REM/SLV):		To select output current control mode for local/remote/slave
Remote sensing:		Possible
Voltmeter:		Digital readout (4-1/2 digits), green
Accuracy *7		
When in output voltage indication:		0.05% rdg + 0.02% fs + 1 digit

*6: If your PAR has no control board which is optional, the output voltage will be zero when the LOC/REM/SLV switch is set to the REM or the SLV position.

*7: Temperature 23°C ±5°C (73.4°F ±9°F), warm-up time >20 minutes

<u>Item</u>	<u>PAR 80A</u>	<u>PAR 160A</u>
When in LIMIT indication:	0.05% rdg + 0.05% fs + 1 digit	
When in OVP indication:	0.05% rdg + 0.05% fs + 1 digit	
When in EXT indication:	0.03% rdg + 0.02% fs + 1 digit	
Maximum allowable input voltage		
Normal mode:	200 V	
Common mode:	100 V	
Ammeter:	Digital readout (3-1/2 digits), green	
Accuracy *7		
When in output current indication:	0.5% rdg + 1 digit	
When in LIMIT indication:	0.5% rdg + 1 digit	
Protective Circuits		
Overvoltage protector (OVP):	Turns off input switch	
Set voltage adjustment range:	Approx. 0 - 90 V	
Overheat protector:	Turns off input switch	
Trip temperature:	Heat sink temperature approx. 90°C (149°F)	

853574

85 35 75

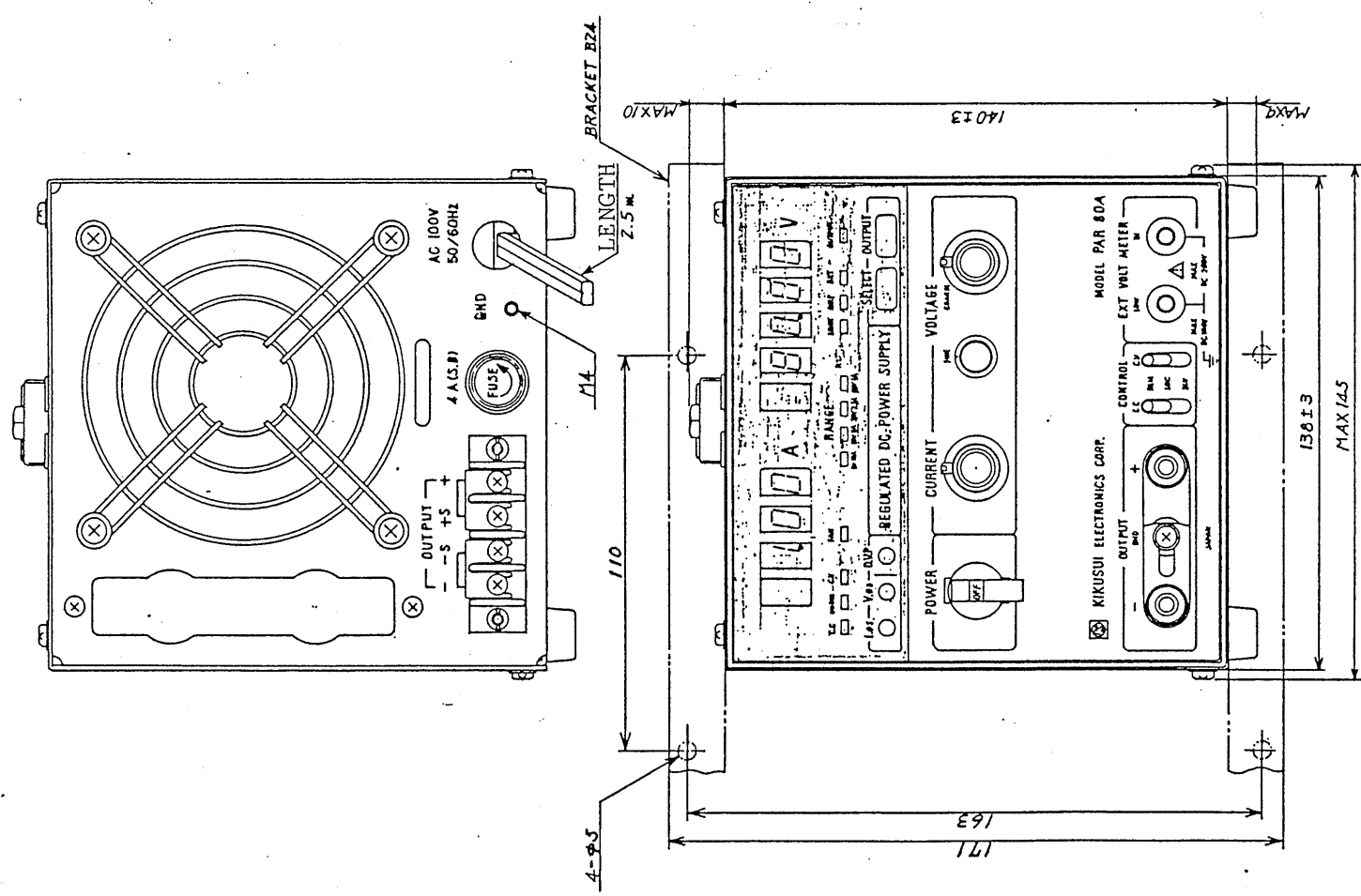

Notes: Two types of rack mount brackets, namely B11 and B24, are available. This illustration is for B24.

Overall Dimensions of PAR 80A Power Supply

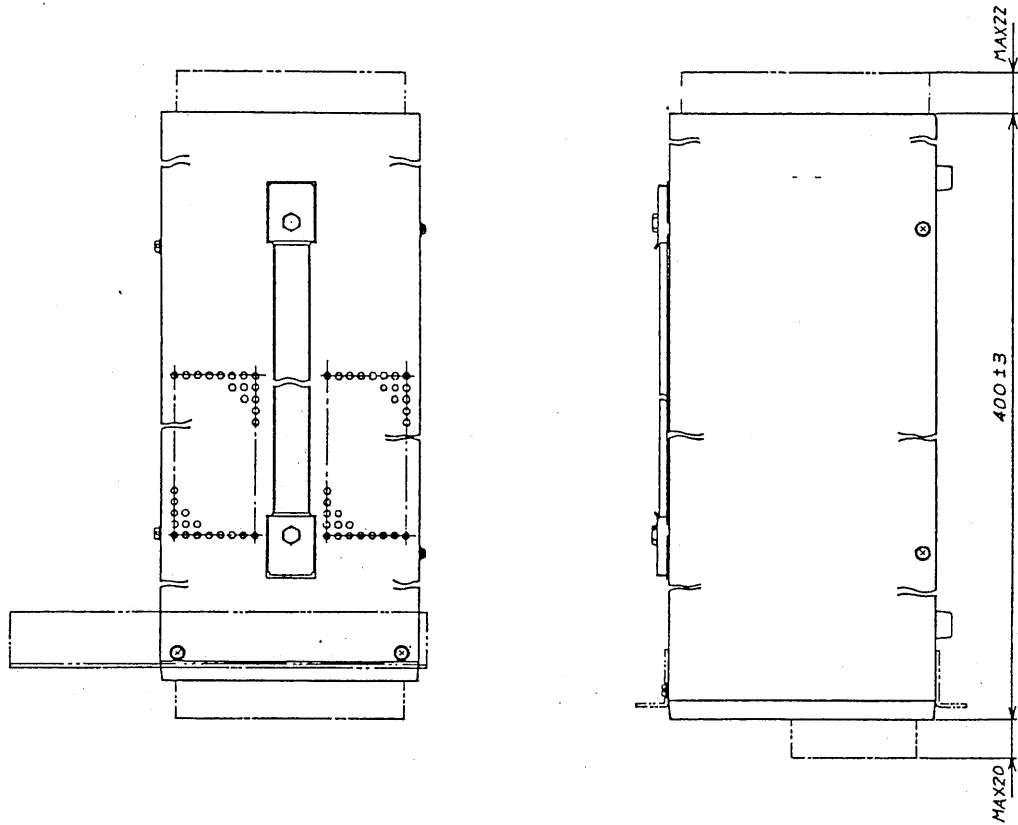
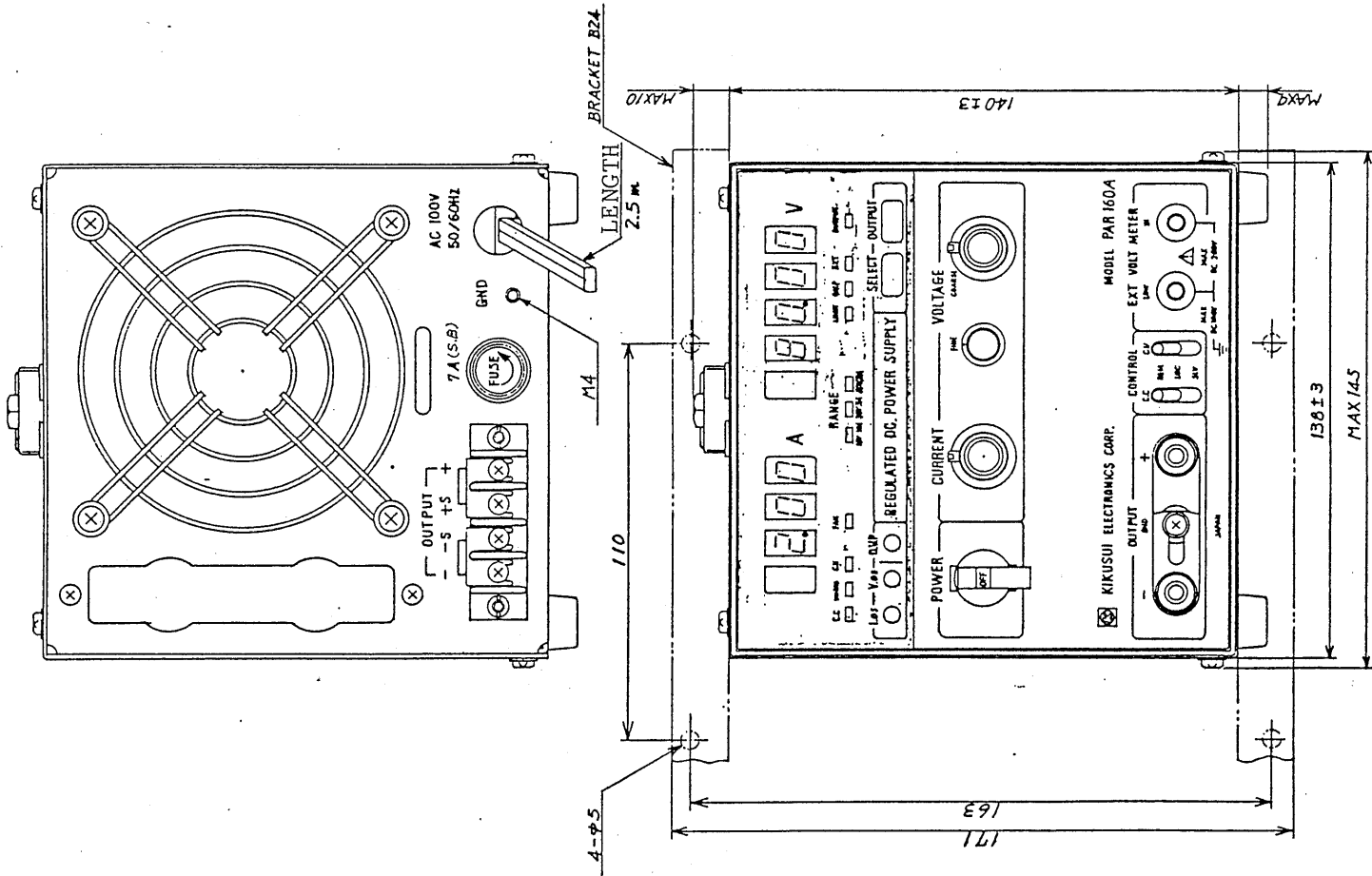

Notes: Two types of rack mount brackets, namely B11 and B24, are available. This illustration is for B24.

Overall Dimensions of PAR 160A Power Supply

2. OPERATING INSTRUCTIONS

2.1 General Precautions

(1) Input Voltage

Make sure that the line voltage on which you are going to operate your PAR is within a range of $\pm 10\%$ from the nominal input voltage requirement of your PAR. The nominal input voltage is indicated near the power cord on the rear panel.

(2) Input Fuse

Note that the input fuse differs by the input voltage. Make sure that the fuse installed on your PAR conforms with the rating indicated on the rear panel.

(3) Ambient Temperature

The PAR operates for the specification performance within an ambient temperature range of 0 to 40°C (32 to 104°F). Be sure to operate the PAR within this temperature range. Note that the longevity of the components will be adversely affected if the power supply is operated in high ambient temperatures. Note also that operation of the power supply may become unstable if it is operated at temperatures lower than 0°C (32°F).

(4) Environments

- o Do not block the air ventilation openings (top and bottom).
- o Hot air comes out of the fan air blow out opening. Keep a clearance of 30 cm or more between the opening and the wall. Do not place near the opening any objects which are not heat resistant.

- o Avoid operating the power supply in a highly humid or dusty environments.
- o The place of use must be reasonably free from vibration.
- o Do not put a sensitive instrument on or near the power supply.

853578

2.2 Panel Features and Operation

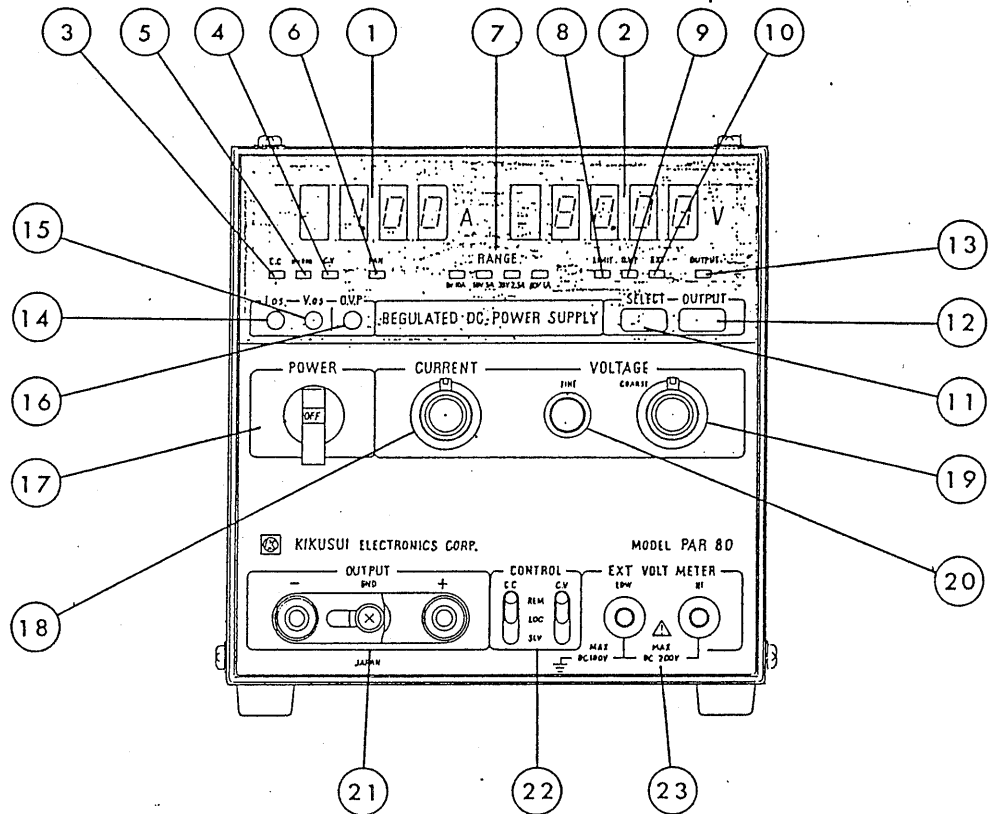

- ① **AMMETER:** Normally, the ammeter indicates the output current. Only when the LIMIT lamp ⑧ is on, the ammeter indicates the set current value for CC operation (or the current limit value if in the CV mode).
- ② **VOLTMETER:** Normally, the voltmeter indicates the output voltage (between +S and -S terminal).
 When the LIMIT lamp ⑧ is on, the voltmeter indicates the set voltage for CV operation (or the voltage limit value if in the CC mode).
 When the OVP lamp ⑨ is on, the voltmeter indicates the set voltage for OVP operation.

When the EXT lamp (10) is on, the voltmeter indicates the external voltage applied to the EXT VOLTMETER terminals (23).

- (3) CC lamp: Indicates that the power supply is in the constant-current mode.
- (4) CV lamp: Indicates that the power supply is in the constant-voltage mode.
- (5) UNREG lamp: Indicates that the output setting (combination of current and voltage) exceeds the output capacity of the power supply and the output is being restricted.
- (6) FAN lamp: Indicates that the fan is running. When the load is light, the fan can be kept unused. For details, refer to (30) FAN.
- (7) RANGE lamps: The illuminating one of these lamps indicates the existing output range (combination of voltage and current). The ranges are automatically switched by the output voltage.
- (8) LIMIT lamp: Indicates that the voltmeter and ammeter are for the limit voltage and current, respectively. The LIMIT mode is selectable with the SELECT switch (11).
- (9) OVP lamp: Indicates that the voltmeter is for the set voltage for OVP operation. The set voltage is adjustable with the OVP control (16). The OVP mode is selectable with the SELECT switch (11).
- (10) EXT lamp: Indicates that the voltmeter is for the external voltage applied to the EXT VOLTMETER terminals (23). The EXT mode is selectable with the SELECT switch (11).

053580

- ⑪ SELECT switch: Selects the LIMIT/OVP/EXT modes for the volt-
meter and ammeter. As you press this switch
repeatedly, the modes are changed in the sequence
of LIMIT → OVP → EXT → initial state (none of the
three lamps is on). Even if you press this switch
when the power supply is in operation, its output
is not affected.
- ⑫ OUTPUT switch: Each time as you press this switch,
the output is turned on or off. When the output is on,
the OUTPUT lamp 13 illuminates. When the INPUT
switch is turned on, the ON/OFF sequence is at
the OFF stage. When in the OFF state, the output
voltage is 0 to -0.4 V.

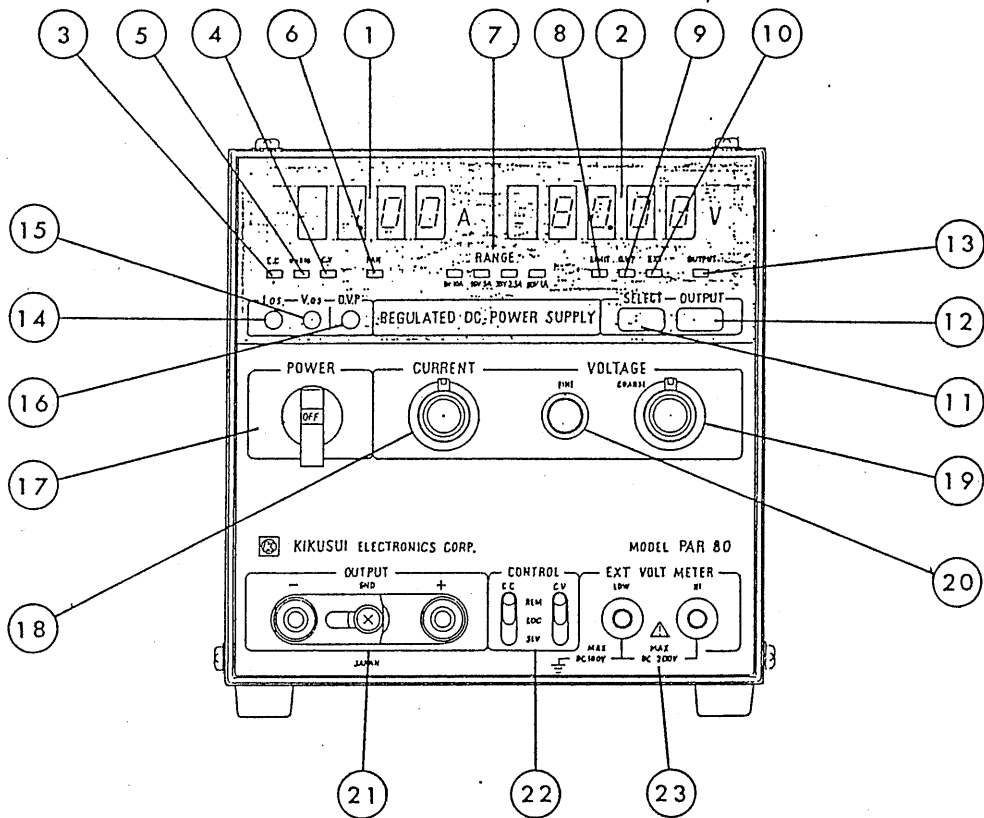

- ⑬ OUTPUT lamp: Indicates that the output is in the ON state.
- ⑭ I_{OS} control: To adjust offset of current when in remote control through the control board.
(The control board is optional.)
- ⑮ V_{OS} control: To adjust the offset of voltage when in remote control through the control board.
(The control board is optional.)
- ⑯ OVP control: To adjust the set voltage for overvoltage protection. When the OVP mode is selected with the SELECT switch ⑪, the set voltage is indicated by the voltmeter ②.
- ⑰ POWER switch: The main input power switch. The switch cuts out the main power of the power supply when it is overheated or its OVP has tripped. Before turning on the switch again, allow a pause period of 5 seconds or more.
- ⑱ CURRENT control: To set the output current. 10-turn potentiometer.
- ⑲ VOLTAGE (COARSE) control: To set the output voltage. 10-turn potentiometer.
- ⑳ VOLTAGE (FINE) control: To set the output voltage. 1-turn potentiometer.
- ㉑ OUTPUT terminals: Deliver the output. The red terminal is for "+" and the white terminal for "-". To the GND terminal, the accessory GND terminal can be connected.

Note: When making wiring employing a pair-plug or a similar device, be sure to employ a device of a sufficient current rating.

- ②② CONTROL switches: Select the control mode for local, remote or slave, for CV or CC operation.
- LOC position: The output voltage and current can be locally controlled with the VOLTAGE and CURRENT controls on the front panel of the power supply.
- REM position: The output voltage and current can be remotely controlled through the control board. The panel controls remain idle. If no control board is provided, the output voltage and current are approximately zero.
- SLV position: This position is for series or parallel slave operation of the power supply. The control board is necessary for this mode of operation.

Note: The remote control board is optional.

- ②③ EXT VOLTMETER terminals: Floating input terminals for measurement of external voltage. The maximum allowable input voltage is 200 V. However, do not apply any input voltage which is floated by 100 V or more from the GND potential.

Note: Minimum readout of the EXT VOLTMETER is 199.99. If the measured value is 200.00 or over, the display indicates overflow (Blinking).

- ②④ Space for option: Space for the control board.
- ②⑤ OUTPUT terminals: Output terminals (+) and (-) and sensing terminals (+S) and (-S). Normally, the shorting pieces ②⑥ are connected between terminals (+) and (+S) and between (-) and (-S).
- ②⑥ Shorting pieces: To short between terminals (+) and (+S) and between (-) and (-S).

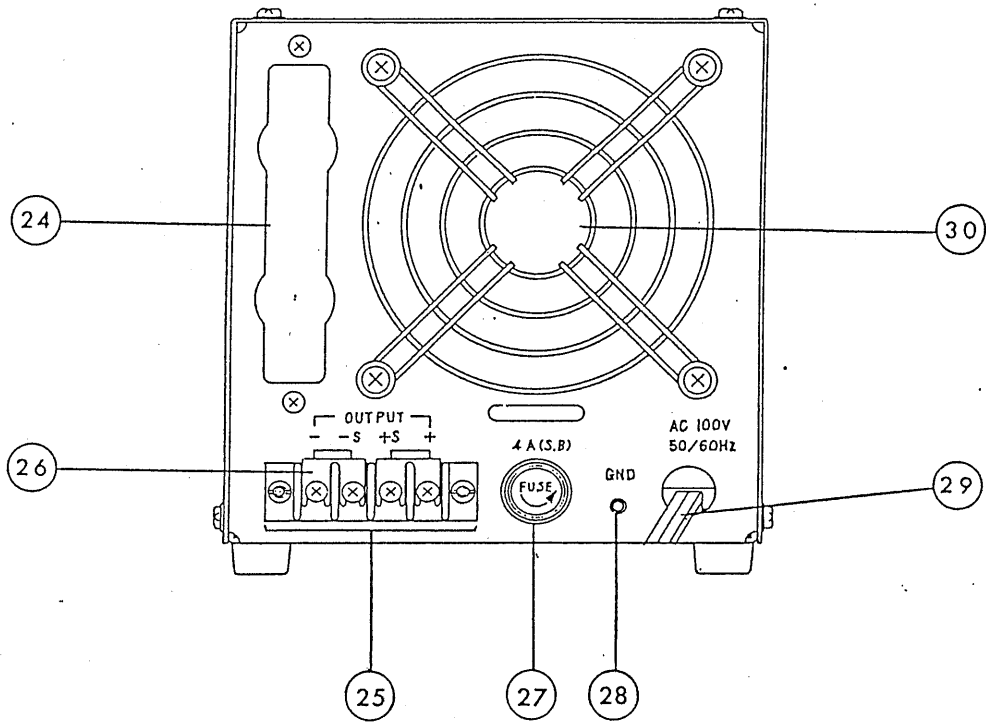

- ②⑦ FUSE: The input power fuse. The fuse holder cap can be removed by turning it counter-clockwise. The fuse is 6.4 mm dia. and 32 mm long.
- ②⑧ GND: To ground the power supply to the earth potential. M4 threaded hole.
- ②⑨ AC cable: AC power cord (2-wire parallel cord). Do not sharply bend the cord and do not put any heavy objects on the cord.

③⑩ Fan:

The fan starts running when one or both of the following conditions are met.

Internal temperature: Higher than 60°C (140°F)

Output current: Approx. 1 A

The fan which has started running does not stop until you turn off the POWER switch ①⑦.

For a light load which draws only a small current, the power supply can be operated silently without running the fan.

Note: If the power supply is installed on a rack or if it has the remote control board, set the FAN switch as follows so that it runs even at no load.

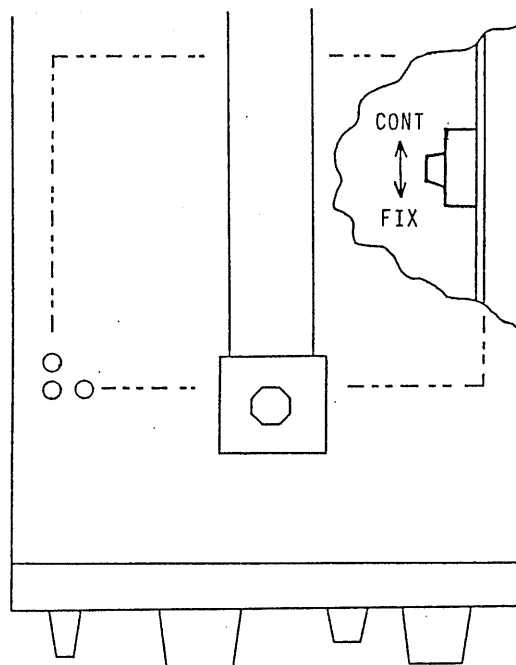

The FAN switch is located inside of the power supply.

Turn off the POWER switch and throw the FAN switch to the FIX position using an insulative small rod. The FAN will start unconditionally as the POWER switch is turned on.

853585

2.3 Operation Method

2.3.1 Output Ranges of PAR 80A and PAR 160A

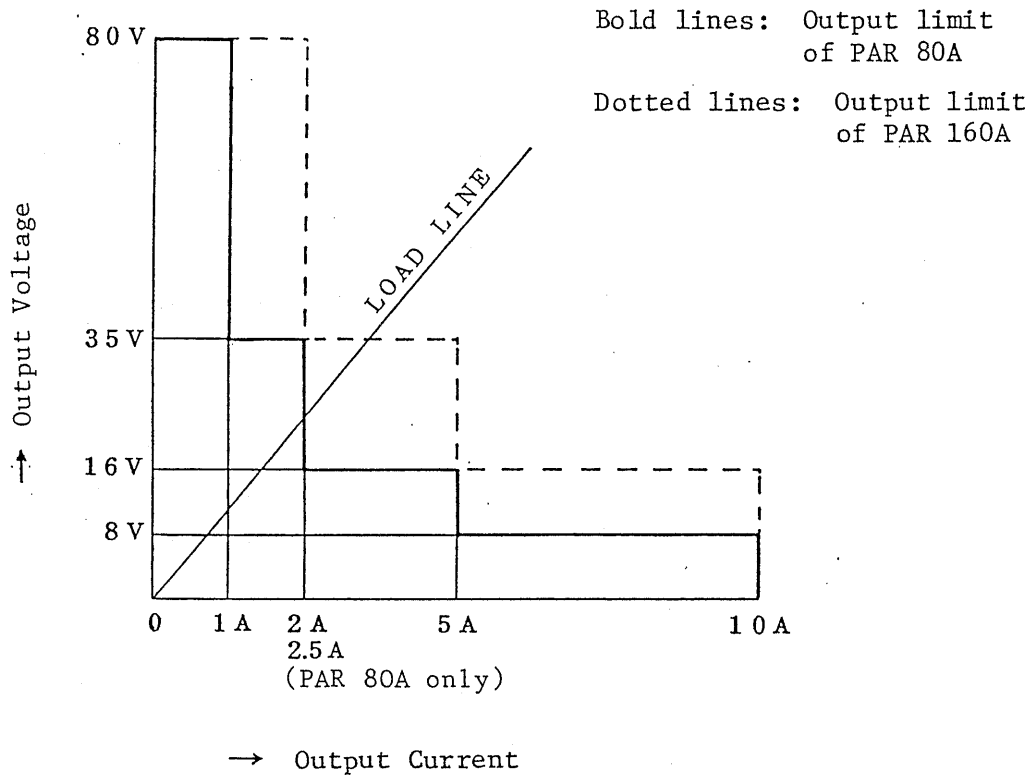

The output ranges of the PAR Series Power Supplies are as shown in the above. When the output is on a bold line (dotted line), the UNREG lamp illuminates to indicate that the output is at the limit of the range. The vertical output limit lines denote the limits in the constant-current mode and the horizontal output limit lines denote the limits in the constant-voltage mode.

When the output is set at 80 V and 10 A and then it is changed from no load to shorting, the output changes from 80 V and 0 A to 0 V and 10 A on the output limit lines repeating the CC and CV modes.

The UNREG lamp does not illuminate when at the 80-volt limit or 10-ampere limit as they are the highest limits of output setting.

2.3.2 Constant-voltage Operation

- (1) Set both CONTROL switches (CC and CV) to the LOC positions.
- (2) Connect the load to the power supply, using wires of a sufficient current rating and paying attention to polarity.
- (3) Turn on the POWER switch. Certain indicator lamps will illuminate. Since the OUTPUT switch is off, the output voltage will be -0.4 to zero volts and the output current approximately zero amperes.
- (4) Press the SELECT switch once. The LIMIT lamp will illuminate indicating that the power supply is in the LIMIT mode. No output voltage will be delivered yet.
- (5) Set the voltage at the required value with the VOLTAGE control. Set the current at a value slightly higher than the anticipated value with the CURRENT control. If the load current is a pulse current, take the peak value for the above setting.
- (6) Press the SELECT switch for three times. The meters will be changed to the OVP mode, the EXT mode, and then back to the LIMIT mode. As you press the OUTPUT switch, the output voltage as set in Step (5) will be delivered.
- (7) If the CV lamp (green) is on, the power supply is normally operating in the constant-voltage mode. If the CC lamp (red) is on, the current set in Step (5) is too small and the power supply is operating in the current-limit mode. If the UNREG lamp (yellow) is on, the setting of "voltage \times current" is exceeding the output rating of the power supply.

Notes: 1. The voltmeter indicates the voltage between terminals $(+S)$ and $(-S)$. The voltage at the load can be lower than the value read on the voltmeter by several tens to several hundreds millivolts due to voltage drops caused by the contact resistances at the output terminals and resistances of the wires from the power supply

to the load. If the errors caused by these voltage drops are intolerable, voltage setting can be made by selecting the EXT mode with the SELECT switch and reading the load terminal voltage on the voltmeter.

2. The digital voltmeter reading will require a period of several seconds before it is stabilized after the POWER switch is turned on. This transient instability is only within the meter circuit and does not mean overshoots of the power supply output voltage.

2.3.3 Remote Sensing Operation

When the voltage drop caused by the resistances of the contacting points and leadwires connecting the power supply to the load, the remote sensing operation can be employed to regulate directly the voltage which appears at the load end. For this operation, proceed as follows:

- (1) Turn off the POWER switch.
- (2) Disconnect the shorting bars from between terminals (+) and (+S) and between (-) and (-S) on the rear panel.
- (3) Connect the (+S) and (-S) terminals to the point (such as load) whose voltage is to be regulated. (For this connection, use a shield cable in order to prevent induction ripple noise. Connect the shielding wire (outer braided wire) to terminal (+).

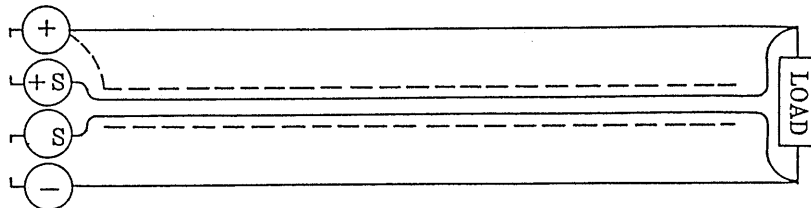

853588

Performance with remote sensing operation:

With the remote sensing operation, a voltage drop of up to approximately 0.6 V can be compensated for on both "+" and "-" lines. The tolerance of compensation is $R/4000$ times of the voltage to be compensated for, where R denotes the resistance of the sensing cable.

Example: Assume that copper wires of gauge 0.2 mm² is used to sense a point 5 meters apart from the power supply and that the copper wire resistance is 100 ohms/km. Since the resistance of the sensing wires for both ways (10 meters), is 1 ohm, the tolerance of compensation is calculated to be $0.6 \text{ V} \times 1/4000 = 0.15 \text{ mV}$.

2.3.4 Constant-current Operation

- (1) Set both CONTROL switches (CC and CV) to the LOC positions.
- (2) Connect the load to the power supply, using wires of a sufficient current rating and paying attention to polarity.
- (3) Turn on the POWER switch. Certain indicator lamps will illuminate. Since the OUTPUT switch is off, the output voltage will be -0.4 to zero volts and the output current approximately zero amperes.
- (4) Press the SELECT button once. The LIMIT lamp will illuminate indicating that the power supply is in the LIMIT mode. No output current will be delivered yet. Set the current at the required value with the CURRENT control. Set the voltage at a value slightly higher than the anticipated value with the VOLTAGE control.
- (5) Press the SELECT switch for three times. The meters will be changed to the OVP mode, the EXT mode, and then back to the LIMIT mode.
- (6) As you press the OUTPUT switch, the output current as set in Step (4) will be delivered.

053589

- (7) If the CC lamp (red) is on, the power supply is operating in the constant-current mode. If the CV lamp (green) is on, the voltage predicted in Step (4) is too low and the power supply is in the voltage-limit mode. If the UNREG lamp (yellow) is on, the setting of "voltage × current" is exceeding the output rating of the power supply.

2.3.5 To Use the OVP Function

The OVP (overvoltage protector) protects the load against overvoltages which can be caused by erroneous manipulation and equipment failures. The OVP lets the input power switch cut out when the output voltage has exceeded a preset level.

OVP voltage setting procedure:

Set the OUTPUT switch to off. Select the OVP mode by pressing the SELECT switch, and the voltmeter will indicate the OVP voltage. Adjust the OVP voltage to the required voltage with the OVP control which is located at upper left on the front panel. To confirm the OVP voltage setting, gradually increase the output voltage and check that the input power switch trips when the output voltage has exceeded the preset voltage.

Sensitivity of OVP circuit:

If the sensitivity of the OVP circuit is too high, the input switch will trip too frequently as the OVP will respond to even narrow pulse noise signals. The sensitivity of this power supply is defined in terms of a pulse width (to trip the OVP circuit by "setting ±10%"). The pulse width typically is 50 milliseconds.

Sensing point for OVP operation:

The OVP circuit detects the voltage between terminals $\textcircled{+S}$ and $\textcircled{-S}$, which represents the load end voltage.

Note: Note that, if the sensing wire of the $\textcircled{-}$ line is disconnected, the output voltage and OVP voltage will rise by about 2%.

2.3.6 External Voltage Measurement

By selecting the EXT mode with the SELECT switch, an external DC voltage can be read on the voltmeter without causing any effects on the output. The external voltage measuring performance is as follows:

Accuracy: 0.03% rdg + 0.02% fs + 1 dgt, at 23°C ±5°C
(73°F ±9°F)

Input Resistance: Approx. 1 MΩ

Maximum Allowable Input Voltage: 200 V

Maximum Common-mode Input Voltage: 100 V (with respect to GND)

Precaution: The HIGH input circuit presents to the + line a larger coupling capacitance than that a regular digital voltmeter does. Note that, if the HIGH input circuit is connected to a high impedance circuit of a device whose common line is connected to that of the power supply, noise can be caused to the high impedance circuit.

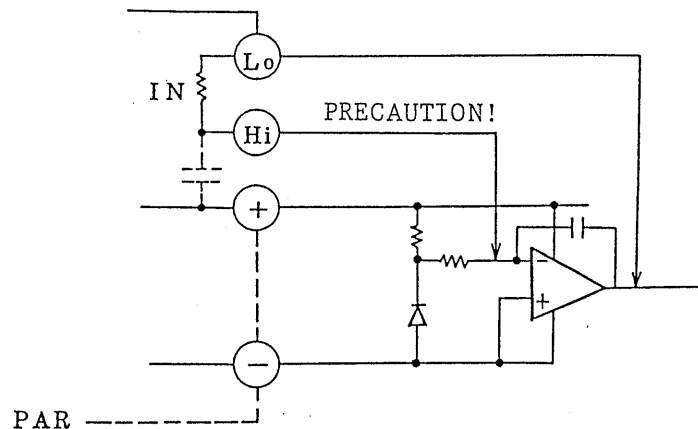

2.3.7 Rack Mount

The PAR Power Supplies can be installed on a rack by using frames and brackets as shown in the following:

Type of Rack	Rack Mount Frame	Brackets
50 mm rack (JIS Spec.)	RMF4M	B11
19 inch rack (EIA Spec.)	RMF4	B24

Up to three units of power supplies can be installed in a rack mount frame as illustrated in the following:

(1) 1 unit

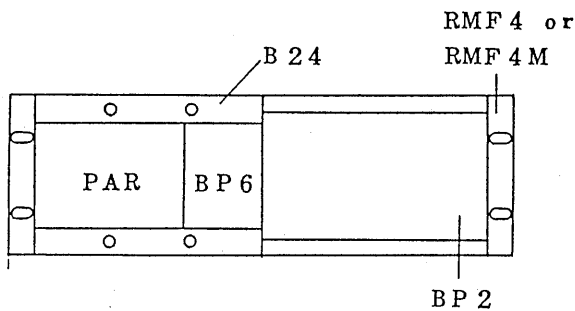

{ RMF4 or RMF4M
B24: 1 set
BP6: 1
BP2: 1

(2) 2 units

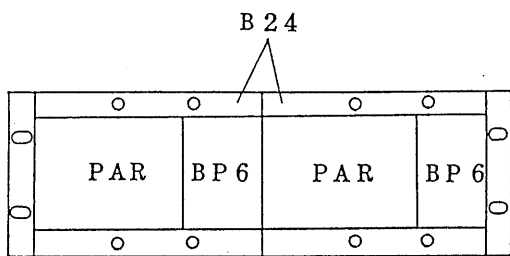

{ RMF4 or RMF4M
B24: 1 set
BP6: 2

(3) 3 units

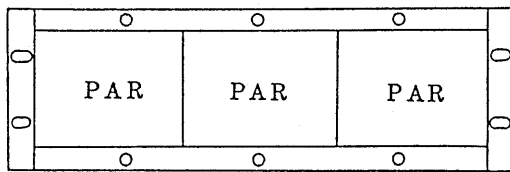

{ RMF4 or RMF4M
B11: 1 set

853592

2.3.8 Control Board

The control board is optional and your power supply may or may not have this board. The functions available with the board are as follows:

[Type APO-R1 Control Board]

- (1) Control of output voltage with external voltage ($\oplus S$ common)
- (2) Control of output voltage with external resistance
- (3) Control of output current with external voltage ($\oplus S$ common)
- (4) Control of output current with external resistance
- (5) To change one of the commons of (1) and (3), (such as to $\ominus S$)
- (6) Master-slave parallel operation of up to three units
- (7) Master-slave series operation of up to three units

- *1: The input resistance in the case of (1) or (3) is approximately 10 k Ω . An input voltage of 10 V is for output 80 V, 10 A.
- *2: In the case of (2) or (4), an external resistance of 10 k Ω is for output 80 V, 10 A.
- *3: It also is possible to control the output with a combination of (1) and (2) or that of (3) and (4).
- *4: In the case of (2), (4) or (5), manipulation of switches is needed when installing the control board.
- *5: In the case of (5), the input resistance is approximately 100 k Ω and an input voltage of 10 V is for output 80 V, 10 A. For the input signal source, a device which is able to provide a sink current of 1 mA or more (such as an operational amplifier) is needed.
- *6: When the control board is employed, performance (ripple characteristics, etc.) may be slightly affected.

*7: When the control board is employed, the fan stop function cannot be made use of, in order to suppress drift which could be caused by internal temperature change of the power supply.

*8: At any time during the remote control mode, control can be immediately returned to the front panel (local mode) by manipulating the REMOTE switch.

3. MAINTENANCE

It is most recommendable to clean and calibrate the power supply at certain time intervals.

3.1 Cleaning

(1) Outside cleaning

When the panels have become dirty, clean them with a cloth moistened with neutral soapsuds and then wipe them with a dry cloth. Do not use benzine, thinner or other chemicals.

(2) Checking the power cord

Check the power cord and plug for breakage and loosening.

(3) Removing the cover

Before removing the cover, make sure that the power cord is disconnected from the line outlet for the sake of safety. To remove the cover, remove the four M4-6 screws from the side panels and the two M3-6 screws from the top panel and then pull up the cover.

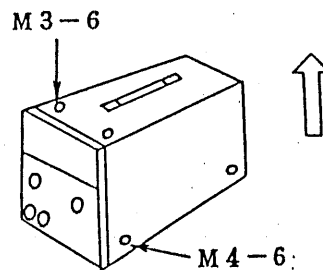

(4) Cleaning the inside

Blow the inside of the power supply using a clean, dry compressed air. Be sure to clean the ventilation openings also.

3.2 Calibration

To calibrate the power supply, as may be called for as it has been subjected to vibration, shock and temperature cycles, observe the instructions given in the following.

(1) General Precautions for Calibration

- o Make sure that the line voltage is within the specification range.
- o Allow a warm-up period of 20 minutes or more. For ammeter calibration, warm up the power supply for a period of 30 minutes or more in the state that the maximum current is drawn.
- o The environments for calibration must be temperature $23^{\circ}\text{C} \pm 5^{\circ}\text{C}$ ($73^{\circ}\text{F} \pm 9^{\circ}\text{F}$) and humidity 85% or lower.
- o The calibrating instruments must be ones fully qualified for calibration and must be warmed up.

(2) Voltmeter Calibration (EXT Mode)

- ① Select the EXT mode with the SELECT switch.
- ② Apply a calibrating voltage of 199.00 V to the EXT VOLTMETER terminals. Adjust R1 (COARSE) and R2 (FINE) so that the voltmeter reads 199.00 V.

(3) Voltmeter Calibration (Output Voltage)

- ① Manipulate the SELECT switch so that the voltmeter indicates the output voltage (initial mode).
- ② Connect a calibrating DC voltmeter between terminal +S and -S .
- ③ Set the output voltage to 00.00 V as read on the calibrating voltmeter. Adjust R3 so that the voltmeter of the power supply also reads 00.00 V.

- ④ Set the output voltage to 80.00 V as read on the calibrating voltmeter. Adjust R4 so that the voltmeter of the power supply also reads 80.00 V.

(4) Ammeter Calibration

- ① Connect a calibrating ammeter to the output terminals. Warm-up the power supply 30 minutes or more with an output current of 10 A.
- ② Set the output current to 10.00 A as read on the calibrating ammeter. Adjust R5 so that the ammeter of the power supply also reads 10.00 A.

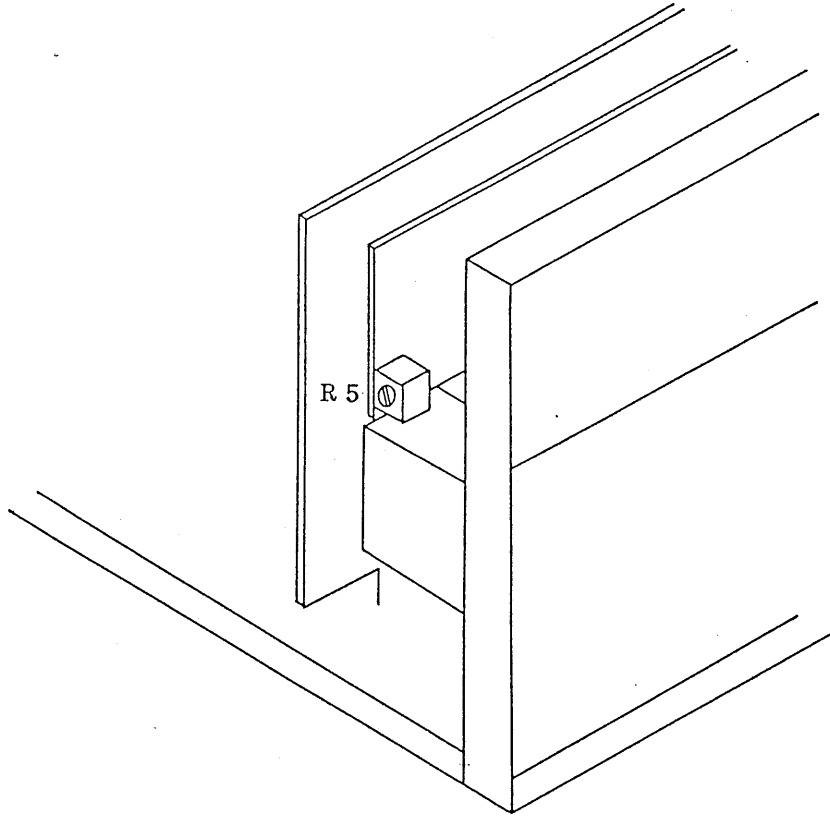
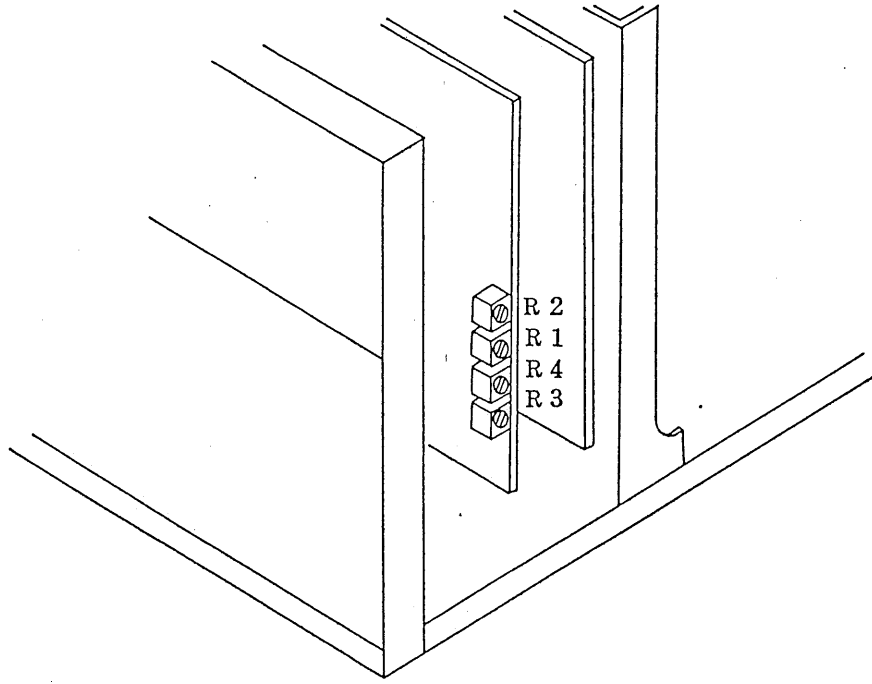

853598 ★