

# OPERATION MANUAL

## REGULATED DC POWER SUPPLIES

**PAB 8-5**

**PAB 18-3**

**PAB 32-2**

**PAB70-1**

**PAB110-0.6**

**PAB160-0.4**

**PAB250-0.25**

**PAB350-0.2**



KIKUSUI ELECTRONICS CORP.

On Power Supply Source, it is requested to replace the related places in the instruction manual with the following items.

( Please apply the item of  $\checkmark$  mark )

- Power Supply Voltage: to .....120.....V AC
- Line Fuse: to .....A
- Power Cable: to 3-core cable ( See Fig. 1 for the colors )

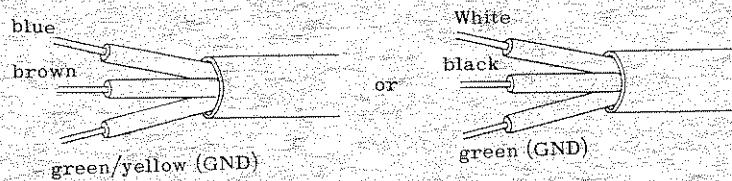

Fig. 1

Please be advised beforehand that the above matter may cause some alteration against explanation or circuit diagram in the instruction manual.

\* AC Plug : In case of the Line Voltage 125V AC or more, AC Plug is in principle taken off and delivered, in view of the safety.

( AC Plug on 3-core cable is taken off in regardless of input voltages. )

Before using the instrument, it is requested to fix a suitable plug for the voltage used.

TABLE OF CONTENTS

	<u>PAGE</u>
1. GENERAL .....	1
2. SPECIFICATIONS .....	2
3. EXPLANATION OF PANEL ITEMS .....	4
4. OPERATION METHOD .....	7
4.1 Operation .....	7
4.1.1 Single Operation .....	7
4.1.2 Series Operation .....	7
4.1.3 Overload Protection when in Series Operation.	8
4.1.4 Parallel Operation .....	9
4.2 Conditions of Use .....	12
4.3 Voltage Drop by Ammeter .....	12
4.4 Current Limiting Circuit .....	12
5. MAINTENANCE .....	14

Schematic Circuit Diagram

## 1. GENERAL

Kikusui PAB Series Regulated DC Power Supplies are compact, light, transistorized series regulator type, and provides larger current rates for its sizes. The output voltage is finely variable for a range of 0 to the rated voltage with a 10-turn potentiometer or a combination of coarse and fine adjustment potentiometers. A voltmeter and an ammeter are mounted on the front panel.

To guard against overload and shorting of the output circuit, PAB Series are incorporated with a constant-current-type current limiting circuit which operates positively. The limiting current value is continuously variable for a range of 10% ~ 100% of the rated current, and PAB Series can be used as a constant-current power supply.

Two units of the same model can be operated in parallel in a one-control mode (master-slave mode) of operation, thereby doubling the output current rating.

Up to four unit can be installed on a 19-inch standard rack, using the frame and mounting brackets which are available as options.

2. SPECIFICATIONS

Model Item	PAB 8-5	PAB 18-3	PAB 32-2	PAB 70-1	PAB 110-0.6	PAB 160-0.4	PAB 250-0.25	PAB 350-0.2
Input power	100 V $\pm$ 10%, 50/60 Hz single-phase AC							
Apparent input power	approx. 115 VA	approx. 130 VA	approx. 140 VA	approx. 150 VA	approx. 130 VA			
Ambient temperature	0 ~ 40°C (32 ~ 104°F)							
Dimensions (maximum dimensions)	106 W × 140 H × 209 D mm (4.17 W × 5.51 H × 8.23 D in.) 111 W × 148 H × 250 D mm (4.37 W × 5.83 H × 9.84 D in.)							
Weight	approx. 3.7 kg (8.2 lb.)							
Accessories	Operation manual, shorting bar, plug for parallel operation							1 each
Terminals	Positive (red) and negative (white) terminals, horizontal positioning							
Floating voltage	$\pm$ 150 V			$\pm$ 250 V		$\pm$ 700 V		
Output voltage Continuously variable	0~8 V	0~18 V	0~32 V	0~70 V	0~110 V	0~160 V	0~250 V	0~350 V
	with coarse and fine control potentiometers				with 10-turn potentiometer			
Output current (maximum)	5 A	3 A	2 A	1 A	0.6 A	0.4 A	0.25 A	0.2 A

Model Item	PAB 8-5	PAB 18-3	PAB 32-2	PAB 70-1	PAB 110-0.6	PAB 160-0.4	PAB 250-0.25	PAB 350-0.2
Ripples	500 $\mu$ V rms			1 mV rms		2 mV rms	3 mV rms	
	(5 Hz ~ 1 MHz)							
Line voltage regulation	0.02% + 2 mV (Note 1)							
Load regulation	0.02% + 3 mV (Note 2)							
Limiting current	Continuously variable for a range of 10% ~ 100% of rated current (constant-current operation)							
Voltmeter (full scale)	8 V	20 V	32 V	70 V	110 V	160 V	250 V	350 V
	JIS Class 2.5							
Ammeter (full scale)	6 A	3.2 A	2.2 A	1.2 A	0.8 A	0.5 A	0.3 A	0.25 A
	JIS Class 2.5							

Note 1: Against  $\pm 10\%$  change of AC line voltage

Note 2: Against 0 ~ 100% change of output current

3. EXPLANATION OF PANEL ITEMS

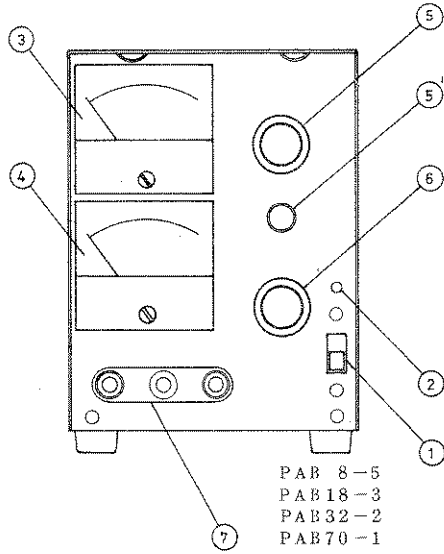

Figure 1

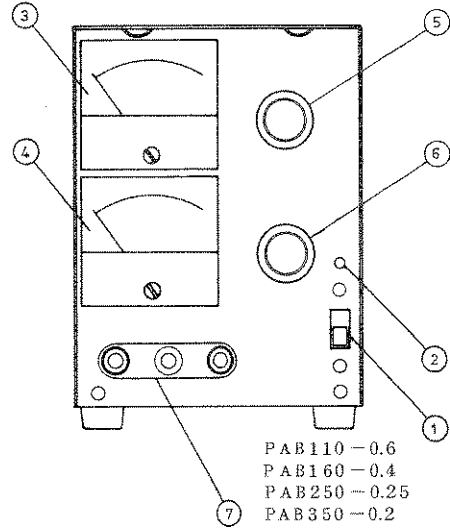

Figure 2

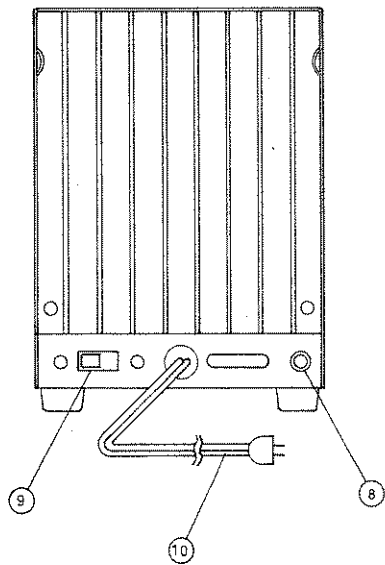

Figure 3

① POWER switch:

A slide switch for ON-OFF control of the instrument main power.

Indication: "POWER ON OFF"

② Pilot lamp:

A power pilot lamp (green LED) which turns on when the instrument is in operation.

③ Voltmeter:

A DC voltmeter which indicates the output voltage of the power supply.

④ Ammeter:

A DC ammeter which indicates the output current of the power supply.

⑤ ⑤' Output voltage control knobs:

Potentiometers for setting the output voltage at the required value. Model PAB110-0.6 ~ PAB350-0.2 use a 10-turn potentiometer. Other models use a coarse adjustment potentiometer ⑤ and a fine adjustment potentiometer ⑤

Indication: "VOLTAGE"

"COARSE, FINE" (Except PAB110-0.6 ~ PAB350-0.2)



⑥ Output current control knob:

Sets the limiting value of the output current, within a range of 10 ~ 100% of the rated current.

Indication: "CURRENT"

⑦ Output terminals:

Binding post terminals for the output power. Normally, the positive or negative terminal is jumpered with the shorting bar to the center screw which is electrically connected to the chassis. It also is possible to provide a DC bias within the rated floating voltage with respect to ground.

⑧ Jack for parallel operation:

Jack for one-control parallel operation, by connecting with the plug (supplied). (Details of parallel operation are explained at a later part of this instruction manual.)

⑨ Master/slave switch:

Switch for selecting the master/slave unit for one-control parallel operation. (Details of parallel operation are explained at a later part of this instruction manual.)

⑩ AC cable with plug:

AC input power cable; approximately 2 meters long.

## 4. OPERATION METHOD

### 4.1 Operation

Be sure to connect the GND terminal to a good grounding earth line.

#### 4.1.1 Single Operation

The instrument can be directly used as a power supply. Ensure that the master/slave selector switch on the rear panel is set in the M (master) side.

#### 4.1.2 Series Operation

Two or more units can be operated in series in order to obtain a higher supply voltage. Note, when in this mode of operation, that the voltage of any terminal must not be higher than the rated floating voltage against chassis. When two units are connected in series, a voltage double of a single unit and a current the same with a single unit can be obtained.

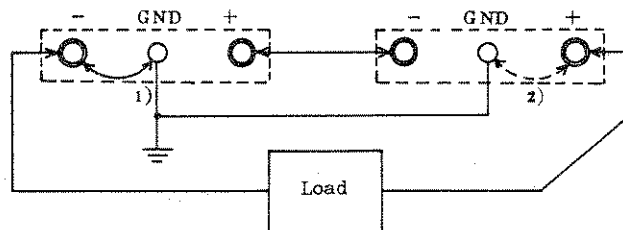

Figure 4

Connect the GND terminal as follows:

(1) For negative grounding:

As indicated with the solid line in Figure 4.

(2) For positive grounding:

As indicated with the dotted line in Figure 4.

Do not connect the GND terminals to terminals of different polarities.

#### 4.1.3 Overload Protection when in Series Operation

If overload is caused with two units are connected in parallel and the protection circuit of one of the two units has tripped, the output voltage of the other unit is applied to the former unit in the reverse polarity and the series control element of the former unit is destroyed. In order to prevent this, a diode is connected in the output circuit of each unit as shown in Figure 5.

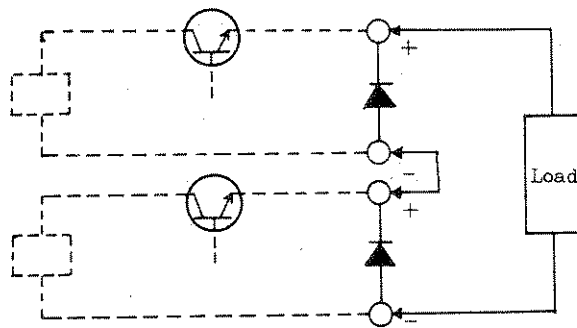

Figure 5.

#### 4.1.4 Parallel Operation (one-control operation)

Two units can be connected in parallel doubled output current. When connecting the units for this operation, be sure to turn off the power switches of the units.

When in the parallel operation, one unit operates as a master unit (M) and the other as a slave unit (S). The output voltage and current are controlled by the master unit. The operating procedure is as follows:

- (1) On the rear panel of the slave unit, throw the master/slave selector switch to the "S" side.
- (2) Connect the output in parallel and connect the parallel operation jack (J4) on the rear panel of the master unit with jack (J4) of the slave unit using the plugs supplied.
- (3) Set the CURRENT knob of the slave unit in the maximum current position (extremely clockwise position). Set the VOLTAGE knob also in the maximum position.
- (4) Turn-ON the power switches.

When the above setting has been done, the output voltage and current can be controlled by the master unit. The controllable output current limit value in this case is 10% ~ 100% of twice of the current rating of one unit.

When in the one-control parallel operation, make sure that a load current of not less than 5% of the rated current flows always. If the load current becomes zero or lower than 5%, the output voltage becomes uncontrollable with the master unit and the potentiometer may be damaged.

When returning to the single unit operation, be sure to return the master/slave switch on the rear panel to the M side.

Regarding the jumper bars, connect them for positive ground or negative ground for both master and slave units. Do not connect them in different polarities. (See Figure 6.)

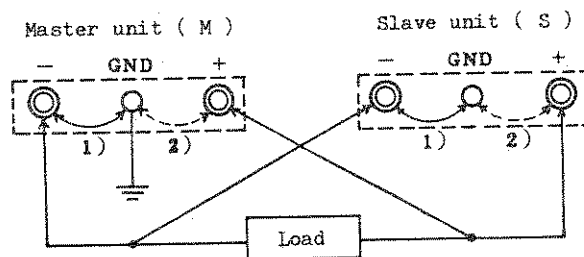

Figure 6

Up to two units of the same model of instruments can be operated in parallel. Instruments of different models cannot be operated in parallel.

Never turn-ON the power switch with the master/slave selector switch set in the S state. The instrument may be damaged if the power switch is turned-ON with the master/slave selector switch set in the S side.

The operatable ranges of two units in series or parallel connection are shown in Figure 7.

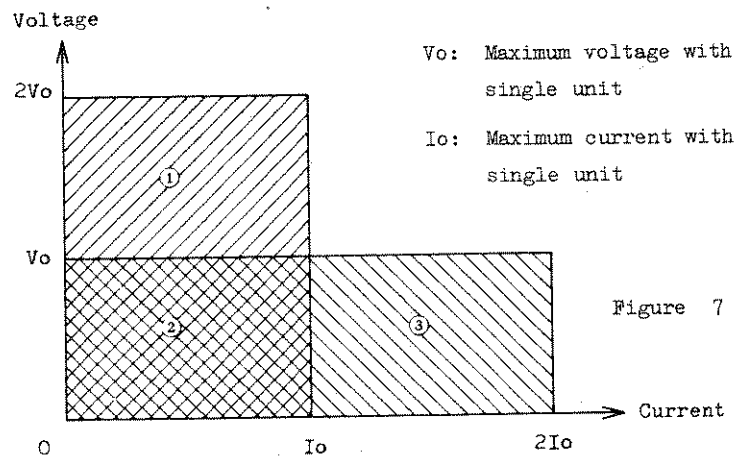

Figure 7

Single-unit operation: Range ②  
 Series operation: Range ① + ②  
 Parallel operation: Range ② + ③

#### 4.2 Conditions of Use

Do not use the instrument in a position where ambient temperature is not within 0 ~ 40°C.

When ventilation is hampered or the instrument is subjected to direct sunlight or other radiation from a heat source, reduce the output current correspondingly. Pay attention to ventilation of the radiator at a rear section of the instrument.

The normal operating AC line voltage range is 90% ~ 110% of the nominal voltage.

#### 4.3 Voltage Drop by Ammeter

The voltage drop caused by the ammeter is automatically compensated for circuitly.

#### 4.4 Current Limiting Circuit

In order to protect the series control element and output ammeter against damage which could be caused when the output circuit is short-circuited by mistake, the instrument is incorporated with an electronic output current limiting circuit which positively operates and limits the current within the preset value. The limiting value can be preset within a range of 10% ~ 100% of

the rated current. When the output current has reached the preset value, the instrument operates as a constant-current supply. When the output current has become lower than the preset value, the instrument automatically resumes its operation as a constant-voltage supply. (See Figure 8.)

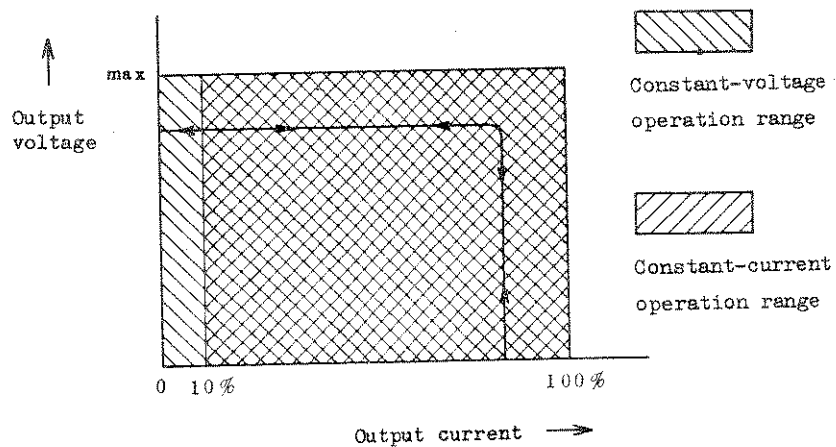

Figure 8

The current limiting circuit provides fairly good constant current regulating characteristics and the instrument can be used as a constant-current supply for most types of loads. The design figures are AC line voltage regulation about 0.1%, load regulation approximately 0.5%, and ripple factor 0.2% rms.



## 5. MAINTENANCE

When the instrument has failed and its component has been replaced or when the meter indication has become shifted, adjust the instrument as explained in this section. First, undo the five screws and remove the cover.

### 5.1 Calibration of Output Voltmeter

With the power switch OFF, perform mechanical zero adjustment of the voltmeter. Next, connect a precision voltmeter (JIS Class 0.5 or equivalent) to the output terminals, set the output voltage at a value close to the maximum voltage, and so adjust the VM CAL potentiometer of the printed circuit board that the voltmeter indicates the same value as the precision voltmeter.

### 5.2 Calibration of Output Ammeter

Perform zero adjustment of the meter under the state that the power switch is turned ON and the instrument is operating normally in the constant-voltage mode. Connect an appropriate load and a precision ammeter (JIS Class 0.5 or equivalent) in the output circuit and calibrate the instrument ammeter by adjusting the AM CAL potentiometer of the printed circuit board.

### 5.3 Adjustment of Output Voltage

With the VOLTAGE control knobs turned to the extremely clockwise position, so adjust the EO CAL potentiometer of the printed board that the output voltage becomes approximately 105% of the rated voltage.

### 5.4 Adjustment of Output Current

With an ammeter connected to the output terminals and the CURRENT control knob turned to the extremely clockwise position, so adjust the IO CAL potentiometer of the printed circuit board that the current reading becomes approximately 110% of the rated current.

Do not tamper with other potentiometers.

