

# OPERATOR'S MANUAL

## JQE 1/4 RACK

## POWER SUPPLY

INCLUDES MODEL SUFFIX D, L, M

KEPCO INC.  
An ISO 9001 Company.

<b>MODEL</b>	<b>CE</b>
<b>100W</b>	
JQE 6-10, JQE 15-6, JQE 25-4, JQE 36-3, JQE 55-2, JQE 75-1.5, JQE 100-1	

### IMPORTANT NOTES:

- 1) This manual is valid for the following Model and associated serial numbers:

MODEL	SERIAL NO.	REV. NO.
-------	------------	----------

- 2) A Change Page may be included at the end of the manual. All applicable changes and revision number changes are documented with reference to the equipment serial numbers. Before using this Instruction Manual, check your equipment serial number to identify your model. If in doubt, contact your nearest Kepco Representative, or the Kepco Documentation Office in New York, (718) 461-7000, requesting the correct revision for your particular model and serial number.
- 3) The contents of this manual are protected by copyright. Reproduction of any part can be made only with the specific written permission of Kepco, Inc.

Data subject to change without notice.

©2010, KEPCO, INC.  
P/N 228-1730



KEPCO, INC. • 131-38 SANFORD AVENUE • FLUSHING, NY. 11355 U.S.A. • TEL (718) 461-7000 • FAX (718) 767-1102  
email: [hq@kepcopower.com](mailto:hq@kepcopower.com) • World Wide Web: <http://www.kepcopower.com>



## Declaration of Conformity

Application of Council directives: **73/23/EEC (LVD)**  
**93/68/EEC (CE mark)**

Standard to which Conformity is declared:

**EN61010-1:1993 (Safety requirements for electrical equipment for measurement, control and laboratory use)**

Manufacturer's Name and Address: **KEPCO INC.**  
**131-38 SANFORD AVENUE**  
**FLUSHING, N.Y. 11352 USA**

Importer's Name and Address:

**REPRESENTATIVE COPY**

Type of Equipment: **Component Power Supply**

Model No.: **[PRODUCT MODEL NUMBER]**

Year of Manufacture:

I, the undersigned, declare that the product specified above, when used in conjunction with the conditions of conformance set forth in the product instruction manual, complies with the requirements of the Low Voltage Directive 73/23/EEC, which forms the basis for application of the CE Mark to this product.

Place: **KEPCO Inc.**  
**131-38 Sanford Ave.**  
**Flushing, N.Y. 11352 USA**

**Saul Kupferberg**  
**(Full Name)**

Date: \_\_\_\_\_

**VP OF SALES**  
**(position)**

## Conditions of Conformance

When this product is used in applications governed by the requirements of the EEC, the following restrictions and conditions apply:

1. For European applications, requiring compliance to the Low Voltage Directive, 73/23/EEC, this power supply is considered a component product, designed for "built in" applications. Because it is incomplete in construction, the end product enclosure must provide for compliance to any remaining electrical safety requirements and act as a fire enclosure. (EN61010-1 Cl. 6, Cl. 7, Cl.8, Cl. 9 and EN61010-1 annex F)
2. This power supply is designed for stationary installation, with mains power applied via a detachable power supply cord or via direct wiring to the source power terminal block.
3. This power supply is considered a Class 1 (earthed) product, and as such depends upon proper connection to protective earth for safety from electric shock. (EN61010-1 Cl. 6.5.4)
4. This power supply is intended for use as part of equipment meant for test, measurement and laboratory use, and is designed to operate from single phase, three wire power systems. This equipment must be installed within a suitably wired equipment rack, utilizing a three wire (grounded) mains connection. See wiring section of this manual for complete electrical wiring instructions. (EN61010-1 Cl. 6.5.4 and Cl.6.10.1)
5. This power supply has secondary output circuits that are considered hazardous, and which exceed 240 VA at a potential of 2V or more.
6. The output wiring terminals of this power supply has not been evaluated for field wiring and, therefore, must be properly configured by the end product manufacturer prior to use.
7. This power supply employs a supplementary circuit protector in the form of a circuit breaker mounted on the front panel. This circuit breaker protects the power supply itself from damage in the event of a fault condition. For complete circuit protection of the end product, as well as the building wiring, it is required that a primary circuit protection device be fitted to the branch circuit wiring. (EN61010-1 Cl. 9.6.2)
8. Hazardous voltages are present within this power supply during normal operation. All operator adjustments to the product are made via externally accessible switches, controls and signal lines as specified within the product operating instructions. There are no user or operator serviceable parts within the product enclosure. Refer all servicing to qualified and trained Kepco service technicians.

# SAFETY INSTRUCTIONS

## 1. Installation, Operation and Service Precautions

This product is designed for use in accordance with EN 61010-1 and UL 3101 for Installation Category 2, Pollution Degree 2. Hazardous voltages are present within this product during normal operation. The product should never be operated with the cover removed unless equivalent protection of the operator from accidental contact with hazardous internal voltages is provided:



There are no operator serviceable parts or adjustments within the product enclosure. Refer all servicing to trained service technician.



Source power must be removed from the product prior to performing any servicing.



This product is factory-wired for the nominal a-c mains voltage indicated on the rating nameplate located adjacent to the source power connection on the product's rear panel. To reconfigure the product input for other nominal mains voltages as listed herein, the product must be modified by a trained service technician.

## 2. Grounding

This product is a Class 1 device which utilizes protective earthing to ensure operator safety.



The PROTECTIVE EARTHING CONDUCTOR TERMINAL must be properly connected prior to application of source power to the product (see instructions on installation herein) in order to ensure safety from electric shock.



PROTECTIVE EARTHING CONDUCTOR TERMINAL - This symbol indicates the point on the product to which the protective earthing conductor must be attached.



EARTH (GROUND) TERMINAL - This symbol is used to indicate a point which is connected to the PROTECTIVE EARTHING TERMINAL. The component installer/ assembler must ensure that this point is connected to the PROTECTIVE EARTHING TERMINAL.



CHASSIS TERMINAL - This symbol indicates frame (chassis) connection, which is supplied as a point of convenience for performance purposes (see instructions on grounding herein). This is not to be confused with the protective earthing point, and may not be used in place of it.

## 3. Electric Shock Hazards

This product outputs hazardous voltage and energy levels as a function of normal operation. Operators must be trained in its use and exercise caution as well as common sense during use to prevent accidental shock.



This symbol appears adjacent to any external terminals at which hazardous voltage levels as high as 500V d-c may exist in the course of normal or single fault conditions.



This symbol appears adjacent to any external terminals at which hazardous voltage levels in excess of 500V d-c may exist in the course of normal or single fault conditions.



## TABLE OF CONTENTS

PARAGRAPH		PAGE
<b>SECTION I-INTRODUCTION</b>		
1-1	Scope of Manual .....	1-1
1-3	General Description .....	1-1
1-8	Accessories.....	1-2
1-9	Specifications, Electrical .....	1-2
1-10	Specifications, Mechanical.....	1-4
1-11	Options.....	1-4
<b>SECTION II-INSTALLATION</b>		
2-1	Unpacking and Inspection.....	2-1
2-3	Terminations.....	2-1
2-4	A-C Input Requirements .....	2-2
2-6	Cooling .....	2-2
2-8	Preliminary Check-Out.....	2-2
2-10	Installation.....	2-5/2-6
2-14	Grounding .....	2-5/2-6
<b>SECTION III-OPERATION</b>		
3-1	Standard Power Supply Operation, Local Control .....	3-1
3-4	Remote Error Sensing .....	3-1
3-6	Output Adjustment .....	3-2
3-8	Introduction to Remote Programming .....	3-2
3-10	Equations Showing the Operation of the Kepco Bridge.....	3-2
3-12	Adjustments for Exact Programming Ratio .....	3-3
3-17	General Rules for Remote Programming.....	3-4
3-19	Output Voltage Programming with External Resistance .....	3-5
3-21	Programming by Conductance .....	3-6
3-24A	Maximum Output Current Adjustment.....	3-7
3-25	Remote Programming with External Voltage .....	3-7
3-29	Constant Current Operation.....	3-8
3-34	Series Operation of two or more JQE Supplies .....	3-9
3-40	Parallel Operation of two or more JQE Supplies .....	3-12

## LIST OF ILLUSTRATIONS

FIGURE	PAGE
1-1 Mechanical Outline Drawing.....	1-5
2-1 Location of Internal Controls.....	2-1
2-2 Conversion for 230V a-c Line Operation .....	2-2
2-3 Controls and Terminations, JQE 1/4 Rack Group, Front.....	2-3
2-4 Rear Terminations, JQE 1/4 Rack Group .....	2-4
3-1 Standard Jumper Link Connections, JQE 1/4 Rack Group .....	3-1
3-2 Load Connection Without Error Sensing .....	3-1
3-3 Load Connection Using Remote Error Sensing.....	3-1
3-4 Kepco Power Supply and Comparison Bridge Circuit .....	3-2
3-5 Connections for Precision Programming Ratio Adjustment.....	3-4
3-6 Establishing Programming Linearity .....	3-4
3-7 Remote Resistance Programming.....	3-5
3-8 Remote Conductance Programming .....	3-6
3-9 JQE 1/4 Rack in the Operational Amplifier Mode .....	3-8
3-10 Constant Current Operating Mode .....	3-9
3-11 Automatic Series Connection of JQE 1/4 Rack Power Supplies .....	3-10
3-12 Master/Slave Series Connection of JQE 1/4 Rack Power Supplies .....	3-11
3-13 Automatic Parallel Operation of JQE 1/4 Rack Power Supplies (Graph) .....	3-12
3-14 Automatic Parallel Connection of JOE 1/4 Rack Power Supplies .....	3-13
3-15 Master/Slave Parallel Connection of JQE 1/4 Rack Power Supplies .....	3-14

## LIST OF TABLES

TABLE	PAGE
1-1 JQE 1/4 Rack Group,A-C Input,D-C Output Specifications.....	1-2
1-2 JQE 1/4 Rack Group Output Effects Amplifier Offsets and Reference Specifications .....	1-3
2-1 Internal Adjustments and Calibrations.....	2-1
2-2 Controls and Terminations, JQE 1/4 Rack Group Front.....	2-3
2-3 Rear Terminations JQE 1/4 Rack Group .....	2-4



## SECTION 1 - INTRODUCTION

### 1-1 SCOPE OF MANUAL

- 1-2 This manual contains instructions for the installation, and operation of the Kepco JQE "QUARTER-RACK" Series of Power Supplies.

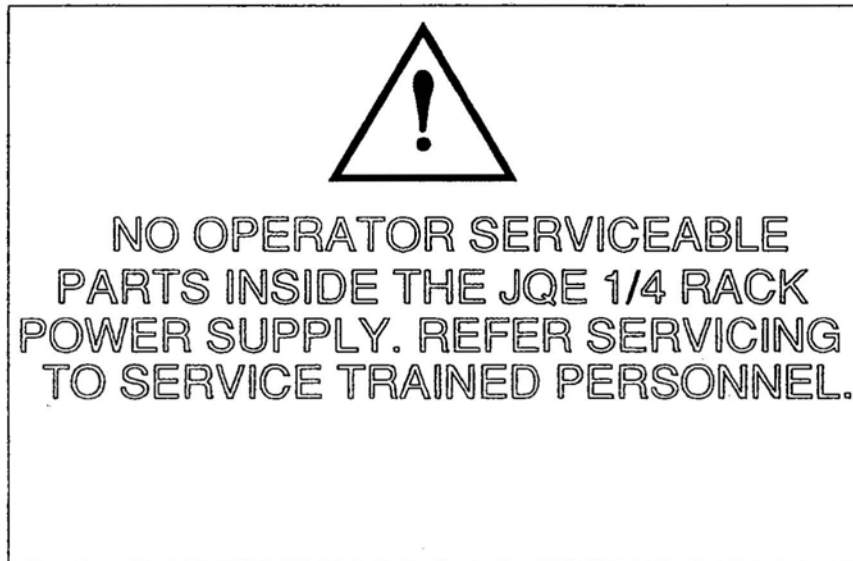

### 1-3 GENERAL DESCRIPTION

- 1-4 Kepco Series JQE Power Supplies are general purpose, precision stabilized voltage the "quarter-rack" configuration. The units are designed to be part of a larger system and not to be operated as a stand alone bench power supply. The units are designed to operate immediately without any internal adjustments. External points on the outside case should not be readily available, provided the unit is in a rack as an integrated OEM subsystem. If it is desired to switch the AC input power range the units must be returned to the factory for authorized service personnel to make the appropriate terminal connections. There are absolutely no serviceable components within the power supply that are accessible for nonauthorized personnel to work on.

JQE Power Supplies have linear, full-dissipation series pass transistors (NPN), driven by an integrated circuit operational amplifier. A sharp current-limit circuit renders the power supply completely short-circuit proof. JQE 1/4 Rack Power Supplies may be readily converted to provide constant current by the addition of an external sensing resistor and a current control resistor. The output of the JQE 1/4 Rack Power Supply is remotely programmable. All necessary connections are available on terminals at the rear barrier-strip.

- 1-5 The compact design of the Kepco JQE 1/4 Rack Series includes a heatsink of exceptional efficiency, in combination with a reliable low-noise fan. JQE 1/4 Rack Power Supplies feature proven design with conservatively rated components for added reliability.
- 1-6 JQE Power Supplies are identical in their mechanical dimensions (Refer to FIG. 1-2) and in their electrical specifications, except as noted in TABLE 1-1.
- 1-7 The main chassis frame of the power supply is constructed from cold-rolled steel, as is the perforate wrap-around cover. The front panel is manufactured from aluminum (Refer to FIG. 1-2 for finish).

**1-8 ACCESSORIES**

- a) RACK ADAPTER (FOR FOUR 1/4 RACK UNITS): KEPKO MODEL RA-24.  
Fits standard EIA rack dimensions.  
FILLER PANELS to cover empty slots if adapter is used for less than its capacity:
  - 1) KEPKO MODEL RFP 24-1, to cover one (1) empty slot.
  - 2) KEPKO MODEL RFP 24-2, to cover two (2) empty slots.
  - 3) KEPKO MODEL RFP 24-3, to cover three (3) empty slots.
- b) RACK ADAPTER (FOR TWO 1/4 RACK UNITS): KEPKO MODEL RA-32. Can be used for two JQE 1/4 RACK models plus three 1/16 RACK UNITS. Use filler panels from the RA-24 system above.

**1-9 SPECIFICATIONS, ELECTRICAL**

- a) A-C INPUT: 105 to 125V a-c or 210 to 250V a-c (selectable, refer to SECTION 11), 50 to 65 Hz<sup>(1)</sup>, single phase. Refer to the table of general specifications (TABLE 1-1) for the a-c input current for each model.
- b) D-C OUTPUT RATINGS: See TABLE 1-1.
- c) OUTPUT EFFECTS: See TABLE 1-2.
- d) OPERATING TEMPERATURE: - 20°C to (+)71°C.
- e) STORAGE TEMPERATURE: - 40°C to (+)85°C.
- f) COOLING: High efficiency, single bearing fan, (permanently lubricated) with special low-noise, non-metal blade.
- g) ISOLATION: A maximum of 500 volts (d-c or p-p) can be connected between chassis and either output terminal. Common-mode current from either output terminal to ground: <5uA rms, < 50uA peak to peak at 115V a-c, 60 Hz.
- h) OUTPUT IMPEDANCE: See TABLE 1-1

(1) Consult factory for operation of the JQE on power line frequencies above 65 Hz

MODEL	D-C OUTPUT RANGE		OUTPUT IMPEDANCE				MAX INPUT AMPS AT 125 VAC
	E <sub>O</sub> max.	I <sub>O</sub> max.	VOLTAGE MODE DC OHMS + SERIES L		CURRENT MODE <sup>(1)</sup> DC OHMS + SHUNT C		
JQE 6-10M	0-6 V	0-10 A	30 μΩ	1 μH	50 kΩ	3 KμF	2.0
JQE 15-6M	0-15	0-6 A	125 μΩ	1 μH	84 kΩ	1 KμF	2.1
JQE 25-4M	0-25 V	0-4 A	300 μΩ	1 μH	125 kΩ	700 μF	2.2
JQE 36-3M	0-36 V	0-3 A	600 μΩ	1 μH	165 kΩ	400 μF	2.2
JQE 55-2M	0-55 V	0-2 A	1.4 mΩ	1 μH	250 kΩ	220 μF	2.3
JQE 75-1.5M	0-75 V	0-1.5 A	2.5 mΩ	1 μH	330 kΩ	160 μF	2.3
JQE 100-1M	0-100V	0-1 A	5 mΩ	2 μH	500 kΩ	110 μF	2.1

1) External current sensing and control using the voltage mode amplifier. Sensing voltage =1 volt.

TABLE 1-1 JQE 1/4 RACK GROUP A-C INPUT AND D-C OUTPUT SPECIFICATIONS

- i) **CURRENT RECOVERY** (For step load voltage): With the JQE as a current stabilizer, the exponential waveform of the compliance (load voltage is a function of the RC time constant formed by the load resistance (R) and the shunt capacitance (C) tabulated in Table 1-1.
- j) **VOLTAGE RECOVERY TIME** (for step load current): The stabilized output voltage returns to the load effect band (or to a level of 10 mV, whichever is greater) in less than 50 usec.
- k) **OVERSHOOT**: No output voltage overshoot from turn-on, turn-off, or power failure for output settings above 25% of maximum rated output voltage. Below 25% output voltage, overshoot is a function of load current and is negligible for loads in excess of 10% of the maximum rated current.

INFLUENCE QUANTITY	OUTPUT EFFECTS		PRE-AMPLIFIER OFFSETS		REFERENCE 6.2±5%	
	VOLTAGE MODE	CURRENT MODE <sup>(1)</sup>	VOLTAGE ΔE <sub>io</sub>	CURRENT ΔI <sub>io</sub>		
SOURCE VOLTAGE (min-max:)	<0.0005%	<0.005%	<10 μV	<2 nA	<0.0001%	
LOAD (No Load - full load):	<0.005% OR 0.2mV <sup>2</sup>	<0.01	<200 μV	<5 nA	N.A.	
TIME ( 8-hour drift):	<0.01% OR 1mV <sup>2</sup>	<0.02%	<20 μV	<2 nA	<0.005%	
TEMPERATURE, Per °C:	<0.01% <sup>3</sup>	<0.02% <sup>(3)</sup>	<20 μV	<5 nA	<0.005%	
RIPPLE AND NOISE <sup>(4)</sup>	RMS	<0.2mV	<0.02% OF I <sub>o</sub> MAX	-	-	-
	p-p <sup>(5)</sup>	<1.0mV	<0.1% OF I <sub>o</sub> MAX	-	-	-

(1) External current sensing using the voltage amplifier. Effects are measured for a 1 volt current sensing voltage drop  
(2) Whichever is greater  
(3) Typical temperature coefficients are 0.005% per °C voltage mode; 0.01% per °C externally sensed current mode  
(4) Measured with the common terminal grounded so that the common mode current does not flow through the load or (in current mode) through a sensing resistor  
(5) Peak-to-peak ripple is measured over a 20Hz to 10MHz bandwidth.

TABLE 1-2 JQE 1/4 RACK, OUTPUT EFFECTS, AMPLIFIER OFFSETS & REFERENCE SPECIFICATIONS.

- l) **VOLTAGE CONTROL:** 10 turn precision rheostat at the front panel; resolution: 0.05% of  $E_{0max}$ . Controls the output voltage from 0 to  $E_{0max}$
- m) **CURRENT LIMIT CONTROL:** A 10 turn precision rheostat at the front panel permits adjustment of the current limit from 1% to 105% of the maximum rated output current ( $I_0$ )
- n) **REMOTE ERROR SENSING:** Rear barrier strip terminals provides for connection of the error sensing leads directly at the load, thus compensating for losses due to load current voltage drop. Up to 0.5v per lead can be compensated.
- o) **REMOTE PROGRAMMING:** Rear barrier terminals provide for remote control of the power supply by resistance (control loop uses 1ma with a programming ratio of 1000 ohms per volt) or external control voltages.
- p) **SERIES/ PARALLEL:** Series operation of the JQE Power supplies is possible up to the rated isolation voltage. Parallel operation using "Automatic Parallel" or "Master Slave " parallel operation may be performed.

#### 1-10 SPECIFICATIONS, MECHANICAL (Refer to FIG 1-2 MECHANICAL OUTLINE DRAWING)

- a) **DIMENSIONS:** Refer to Mechanical Outline drawing Fig 1-2
- b) **TERMINATIONS:** Refer to Mechanical Outline drawing Fig 1-2
- c) **FINISH:**
  - 1) **CHASSIS:** cadmium plated, chromate wash
  - 2) **Panel:** Light grey Color #26440 Federal Standard 595
  - 3) **CASE:** Charcoal grey texture
- d) **METERS:** Two dual range (100% and 10% of  $E_{0,max}$  and  $I_{0max}$ ), 2 inch tautband, recessed panel meters, accuracy 3% of full scale reading for output voltage and output current monitoring.
- e) **MOUNTING:** Rack adapter available, see Accessories (paragraph 1-8).
- f) **SHIPPING WEIGHT:** 19lbs. (8.6kg).

#### 1-11 OPTIONS

JQE Power Supplies with suffix "L" are equipped with locking-type screwdriver-adjustable controls in place of the front panel control knobs. Ignore references in this manual to front panel controls for these models.

JQE Power Supplies with suffix "M" are equipped with front panel analog voltmeter and ammeter.

JQE Power Supplies with suffix "D" are equipped a single digital LCD meter in place of the analog voltmeter and ammeter. Voltage or current measurement is selected by a lighted rocker switch positioned directly below the LCD panel meter.

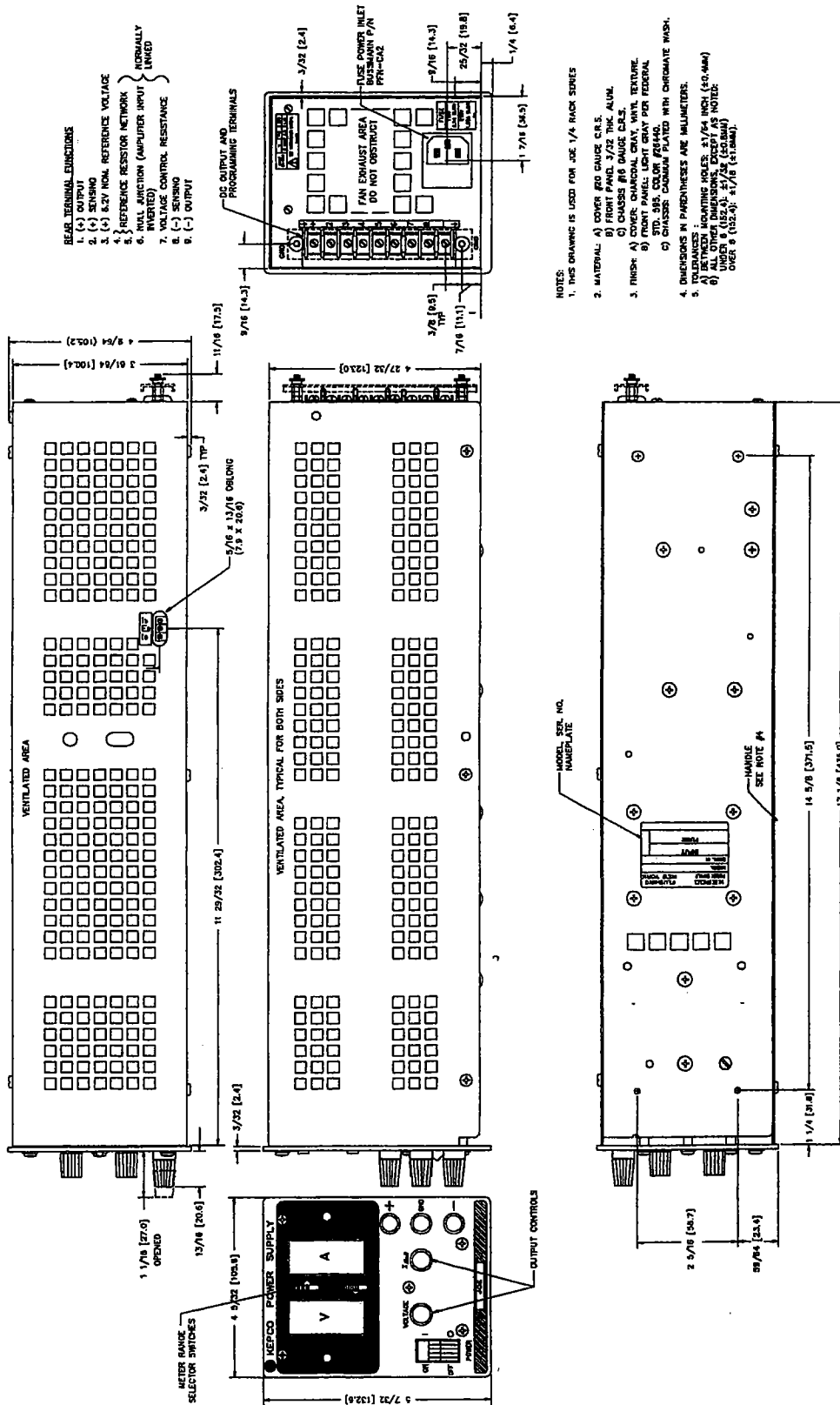

FIGURE 1-1 JQE 1/4 RACK MECHANICAL OUTLINE DRAWING

3041413  
JQE 1/4 RACK/122796



## SECTION II-INSTALLATION

### 2-1 UNPACKING AND INSPECTION

2-2 This instrument has been thoroughly inspected and tested prior to packing and is ready for operation. After careful unpacking, inspect for shipping damage before attempting to operate. Perform the preliminary operational check as outlined in paragraph 2-8 below. If any indication of damage is found file an immediate claim with the responsible transport service.

### 2-3 TERMINATIONS

- a) FRONT PANEL: Refer to FIG 2-3 and TABLE 2-2.
- b) REAR: Refer to FIG. 2-4 and TABLE 2-3.
- c) INTERNAL ADJUSTMENTS AND CALIBRATIONS: Refer to FIG 2-1 and TABLE 2-1

REFERENCE DESIGNATION	CONTROL	PURPOSE	ADJUSTMENT PROCEDURE
R12	I <sub>o</sub> max.adjust	Current Limit Control Cal	par. 3-24A
R13	I <sub>b</sub> adjust	Control Current Calibration	par. 3-16
R11	E <sub>i<sub>o</sub></sub> null adjust	Output Voltage Precision Zero	par. 3-16

TABLE 2-1 ADJUSTMENTS AND CALIBRATION

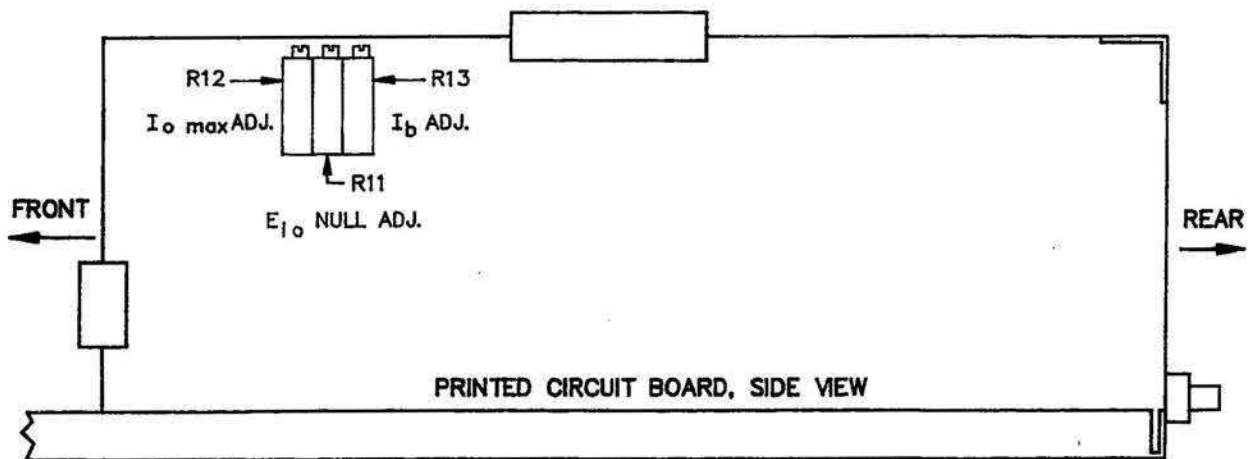

FIGURE 2-1 LOCATION OF INTERNAL CONTROL

## 2-4 A-C INPUT REQUIREMENTS

- 2-5 If it is desired to switch the AC input power range from 105-125 volts a-c to 210-250 volts a-c, the units must be returned to the factory for authorized service personnel to make the appropriate terminal connections. The user should not attempt to open up the unit and switch terminals on the power transformer. Any attempt to do so could cause damage to the unit as well as bodily harm to the user.

## 2-6 COOLING

- 2-7 The power transistors and rectifiers in this power supply are maintained within their operating temperature range by means of a high efficiency heat-sink assembly, cooled by an internal fan. **SIDE PANEL OPENINGS AND THE TOP OF THE CASE MUST BE KEPT-CLEAR FROM OBSTRUCTIONS TO INSURE PROPER AIR CIRCULATION.** Periodic cleaning of the interior of the power supply is recommended. If the power supply is rack mounted, or installed into confined spaces, care must be taken that the temperature surrounding the power supply does not rise above + 71°C.

## 2-8 PRELIMINARY CHECK-OUT

- 2-9 A simple operating check after unpacking and before permanent installation is advisable, to ascertain whether the power supply has suffered shipping damage. Please refer to FIG. 2-3 and FIG. 2-4 for the location of the operating controls and output terminals.
- a) Connect power supply to the 115V a-c line, or refer to paragraph 2-4 for 230V a-c operation if required.
  - b) Turn CURRENT LIMIT CONTROL fully clockwise. Turn VOLTAGE CONTROL fully counterclockwise. Both, VOLTMETER RANGE and AMMETER RANGE SWITCH should be in the "x1" position.
  - c) Turn A-C POWER SWITCH "on". The A-C PILOT LIGHT should be energized. Slowly turn VOLTAGE CONTROL clockwise and observe the gradual increase of the output voltage. Turn counter-clockwise again until about one-tenth of the maximum output voltage is reached. Set VOLTMETER RANGE SWITCH to the "x0.1" position. The VOLTMETER should now read full scale again. Return both, AMMETER and VOLTMETER RANGE SWITCHES to the "x1" position.



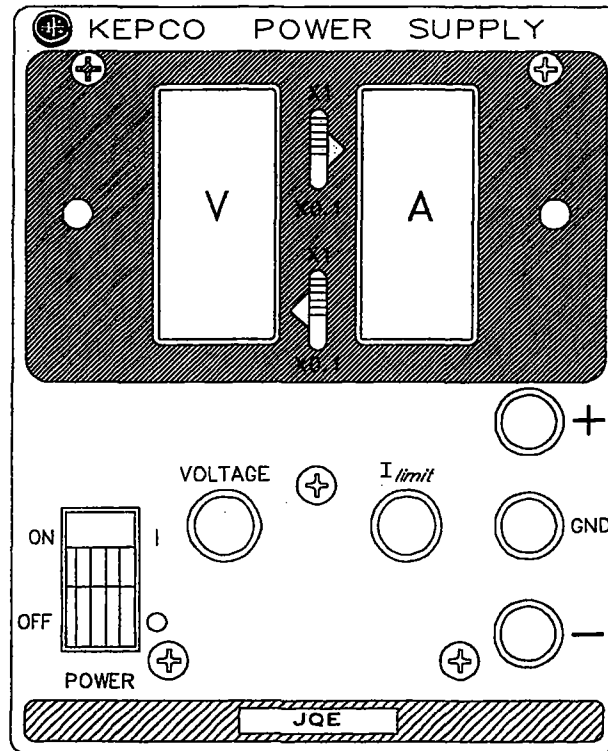

FIG. 2-3 CONTROLS AND TERMINATIONS, JQE 1/4 RACK GROUP FRONT

NO.	TERMINATION OR CONTROL	FUNCTION
1	A-C POWER SWITCH ILLUMINATED	URNS A-C POWER LINE "ON" AND "OFF"
2	VOLTAGE CONTROL	ADJUSTS OUTPUT VOLTAGE FROM 0 TO $E_{0MAX}$
3	VOLTMETER	MONITORS OUTPUT VOLTAGE 0 TO $E_{0MAX}$ TO $0-E_{0MAX}/10$
4	VOLTMETER RANGE SWITCH	CHANGES METER RANGE FROM 0 TO $E_{0MAX}$ TO $0-E_{0MAX}/10$
5	AMMETER	MONITORS OUTPUT CURREN FROM 0 - $I_{0MAX}$ TO $0-I_{0MAX}/10$
6	AMMETER RANGE SWITCH	CHANGES METER RANGE 0 - $I_{0MAX}$ TO $0-I_{0MAX}/10$
7	CURENT LIMIT CONTROL	ADJUSTS CURRENT LIMIT FROM 0 TO 105%
8	PLUS (+) GROUND	POSITIVE LOAD OR MONITORING TERMINAL
9	GROUND	GROUNDING TERMINAL
10	MINUS (-) OUTPUT	NEGATIVE LOAD OR MONITORING TERMINAL

TABLE 2-2 CONTROLS AND TERMINATIONS, JQE 1/4 RACK GROUP FRONT

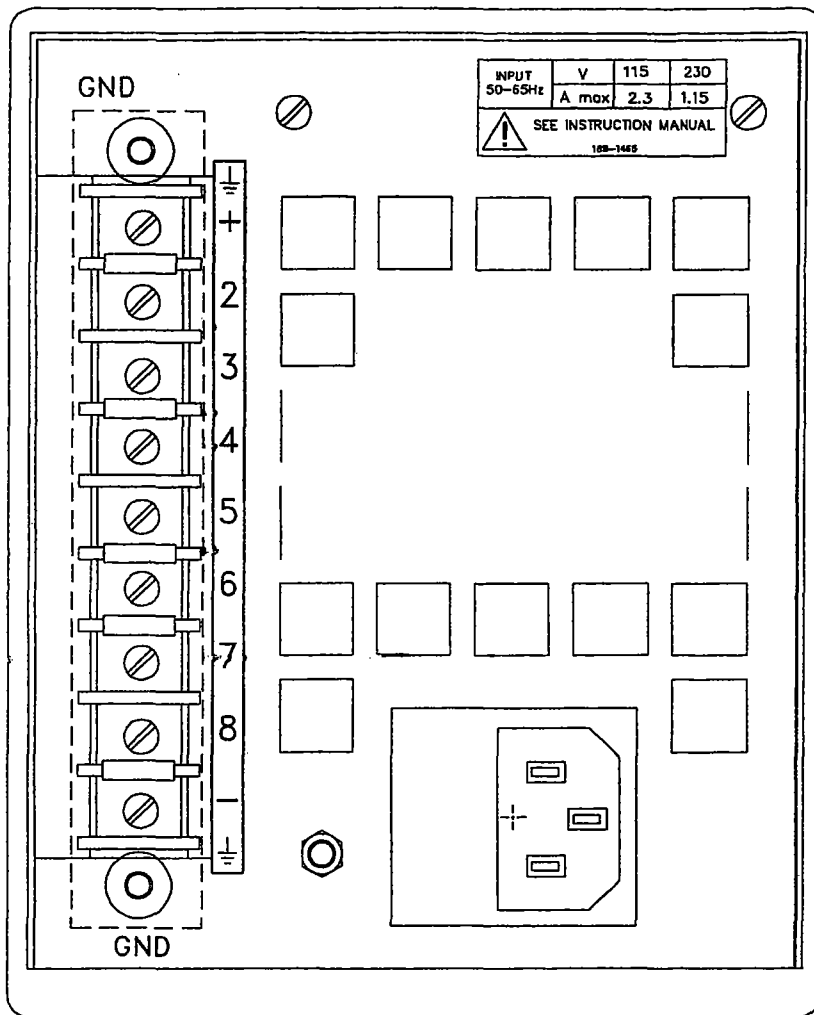

FIGURE 2-4 REAR TERMINATIONS JQE 1/4 RACK GROUP

NO.	TERMINATION	FUNCTION
1	REAR BARRIER STRIP WITH THESE TERMINALS	1 POSITIVE (+) LOAD TERMINAL 2 POSITIVE (+) ERROR SENSING TERMINAL (COMMON) 3 REFERENCE VOLTAGE (Er) (+ 6.2 V nom., 1 mA max.) 4 REFERENCE RESISTOR (Rr) 5 REFERENCE RESISTOR (Rr) 6 NULL JUNCTION 7 VOLTAGE CONTROL (Rvc) 8 NEGATIVE (-) ERROR SENSING TERMINAL 9 NEGATIVE (-) LOAD TERMINAL
2	A-C INPUT AND MAIN FUSE (F201)	ACCEPTS THREE-WIRE A-C POWER LINE CORD (SUPPLIED) PROTECTS MAIN TRANSFORMER AND INPUT CIRCUIT

TABLE 2-3 REAR TERMINATIONS JQE 1/4 RACK GROUP

#### PRELIMINARY CHECK-OUT (cont'd):

- d) Place a short circuit across the output. Turn CURRENT LIMIT CONTROL counter-clockwise. Turn A-C POWER SWITCH "on". Slowly turn CURRENT LIMIT CONTROL clockwise and observe the gradual increase in output current. Turn counter-clockwise until about one tenth of the maximum output current is reached. Set AMMETER RANGE SWITCH to the "x0.1" position. The AMMETER should now read full scale again. Return AMMETER RANGE SWITCH to the "x1" position again.

#### CAUTION

Do not switch to the "x0.1" ranges before the output of the power supply (voltage or current) is below 10% of the maximum rated values.

#### 2.10 INSTALLATION (Refer to FIG. 1-1 "Mechanical Outline Drawing").

- 2-11 For all installations into confined spaces, care must be taken that the temperature immediately surrounding the unit does not exceed the maximum specified ambient temperature (71°C).

#### 2-13 GROUNDING

#### WARNING

#### KEEP INSTRUMENT GROUNDED WHILE IT IS CONNECTED TO THE A-C POWER SOURCE

- a) **A-C GROUND.** The power supply is equipped with a 3-wire safety line cord and polarized plug. The third (green) wire in the line cord is connected to the chassis and the case of the unit. The 3-wire line cord must be connected to a grounded a-c power outlet. If a two-terminal a-c power outlet in combination with an adaptor is used, it is imperative that the chassis of the power supply be returned to a-c ground with a separate lead.
- b) **D-C GROUND.** The d-c output is isolated from the a-c power line and from any direct connection to chassis and ground. The maximum output voltage which can be supported between either output terminal and ground or chassis is 500V d-c, plus the maximum output voltage of the power supply. Either side of the output may be grounded. Convenient grounding terminals are provided at the front panel binding post and at the rear barrier-strip.



## SECTION III—OPERATION

### 3-1 STANDARD POWER SUPPLY OPERATION, LOCAL CONTROL

3-2 **GENERAL.** The JQE ¼ Rack Power Supply is shipped from the factory with five (5) removable jumper links in place at the rear barrier strip (TB1) as shown in FIG. 3-1. THESE LINKS MUST BE IN PLACE AND SECURED TIGHTLY for standard local operation. Loose terminal links or loose wires at the barrier strip will cause malfunction of the power supply.

3-3 **LOAD CONNECTION.** The load may be connected in any of the four ways illustrated in FIG.'s 3-2/3-3. Load connecting wires should be as heavy as practicable since load wire voltage drops will degrade static performance. Twisting of load wires will help preserve the dynamic performance of the JQE power supply.

### 3-4 REMOTE ERROR SENSING

3-5 Specified d-c performance directly at the load requires the use of remote error sensing. A twisted, shielded pair of wires from the sensing terminals directly to the load will compensate for load wire voltage drops up to 0.5 volt per wire (Refer to FIG. 3-3). Observe polarities: The negative sensing wire [from terminal (8)] must go to the negative load wire, and the positive sensing wire [from terminal (2)] goes to the positive load wire.



FIG. 3-1  
STANDARD JUMPER—  
LINK CONNECTIONS  
JQE ¼ RACK GROUP

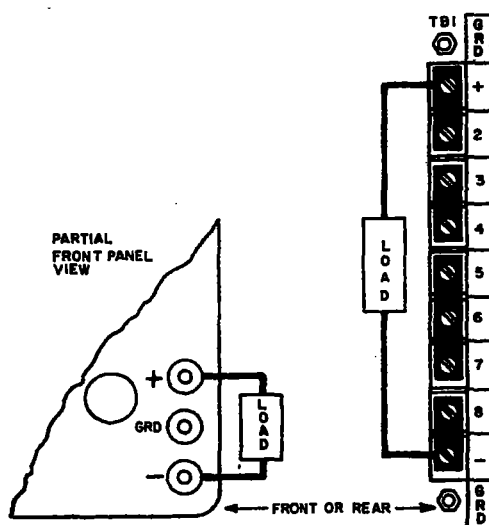

FIG. 3-2 LOAD CONNECTION  
WITHOUT ERROR SENSING

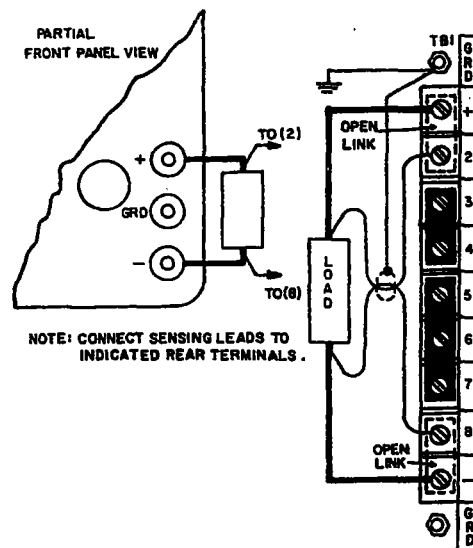

FIG. 3-3 LOAD CONNECTION  
WITH ERROR SENSING.

**NOTE:** If Error Sensing is not used, Specified Performance must be measured at terminals (2) and (8) of TB1.

### 3-6 OUTPUT ADJUSTMENT

3-7 Once the load is connected to the output terminals of the power supply as described in the previous paragraphs, the operating voltage may be adjusted to the desired value by turning the VOLTAGE CONTROL and observing the panel VOLTMETER. The CURRENT LIMIT CONTROL may be set fully clockwise, and will in this position provide limiting at 105% of the maximum rated output current. The CURRENT LIMIT CONTROL may be set to intermediate values, as desired, by first turning the A-C POWER SWITCH to the "off" position and then placing a short circuit across the output. Now the required operating current is adjusted by turning the CURRENT LIMIT CONTROL to the value needed, plus  $\approx 2\%$ . The output current will now limit sharply at this value. After the short is removed from the output, the load is reconnected and the power supply is ready for operation.

### 3-8 INTRODUCTION TO REMOTE PROGRAMMING

3-9 GENERAL. Electrically, the power supply consists of the raw d-c source ( $E_U$ ), the pass element ( $E_p$ ), the d-c error amplifier (A) and a comparison circuit which resembles a four-arm electrical bridge. (Refer to FIG. 3-4). The elements of the bridge are arranged to produce a virtual zero at the amplifier input when the bridge circuit is at balance ( $V_{AA'} = 0$ , when  $E_r/R_r = E_o/R_{VC}$ ). Any tendency for the output voltage to change in relation to the reference voltage ( $E_r$ ) creates an error signal ( $\epsilon$ ) which, amplified by the d-c error amplifier, tends to correct the output voltage towards restoration of bridge balance.

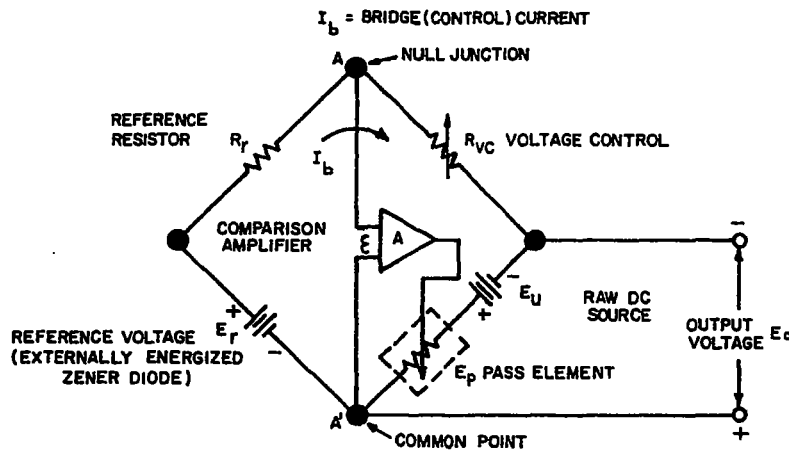

FIG. 3-4 KEPKO POWER SUPPLY AND COMPARISON BRIDGE CIRCUIT.

### 3-10 EQUATIONS SHOWING THE OPERATION OF THE KEPKO BRIDGE

3-11 The following relationships govern the operation of the Kepco Bridge at balance, i.e., with  $V_{AA'} = 0$ :

$$a) \frac{E_o}{E_r} = \frac{R_{VC}}{R_r} \quad (\text{Eq. 1})$$

$$\frac{E_r}{R_r} = I_b \quad (\text{Eq. 2})$$

$$E_o = I_b \times R_{VC} \quad (\text{Eq. 3})$$

Where:  $E_o$  = Output Voltage

$E_r$  = Reference Voltage

$R_r$  = Reference Resistance

$R_{VC}$  = Voltage Control Resistance

$I_b$  = Control Current

b) The ratio of the number of ohms control-resistance needed per volt output is termed the "CONTROL RATIO". It is nominally 1000 ohms per volt in the JQE 1/4 Rack Power Supplies and can be precisely adjusted as shown in paragraph 3-12.

- c) As can be seen from equation (1), the output voltage  $E_o$  can be controlled by varying any one of the three quantities. Rewriting equation (1) we have:

$$E_o = E_r/R_r \times R_{VC}$$

The ratio  $E_r/R_r$  constitutes the control current  $I_b$ . (Eq. 2).

- d) Therefore, we can write:  $E_o = I_b \times R_{VC}$  (Eq. 3).

Making  $I_b$  a precision quantity (precision control current adjustment is described in paragraph 3-12), establishes a precise programming ratio, so that the accuracy of  $E_o$  is solely dependent upon  $R_{VC}$ . This mode of operation is referred to as "RESISTANCE PROGRAMMING" and is covered in detail in paragraph 3-19.

- e) Rewriting Equation (1),  $E_o = E_r \times R_{VC}/R_r$ , leaving the ratio  $R_{VC}/R_r$  fixed, we can make  $E_r$  the variable which controls  $E_o$ .
- f) Other modes of control are possible; some of them are described in the following paragraphs.

**NOTE:** For all programming and adjustment components, use high quality, wire-wound, or metal film resistors with a T.C. of 20 p.p.m. or better.

### 3-12 ADJUSTMENTS FOR EXACT PROGRAMMING RATIO

- 3-13 Referring to equation (3):  $E_o = I_b \times R_{VC}$ , it is seen that if  $I_b = 1$  mA, 1000 ohms of control resistance ( $R_{VC}$ ) is needed for each volt of output. Once  $I_b$  is therefore precisely calibrated, the accuracy and linearity of the output voltage will then solely depend upon  $R_{VC}$ .

To allow for the fact that the value of R102 may change over time, use the following procedure to determine the actual  $I_b$  and the corresponding CONTROL RATIO ( $1/I_b$  with  $I_b$  in mA):

1. Turn the unit off and disconnect the unit from source power.
2. Remove the link between positions 5 and 6 of TB 501.
3. Set the Voltage potentiometer on the front panel to full clockwise.
4. Use a precision digital ohmmeter to measure the resistance between positions 4 and 5 of TB 501. This is the actual resistance of the front panel VOLTAGE control (R102), referred to as  $R_{VC}$  Internal.
5. Use the measured value of R102 to calculate  $I_b$  as follows:  
 $I_b = (E_o + \Delta E_o) / R_{VC}$  Internal.  
 where:  
 $E_o$  is the nominal output voltage (Volts).  
 $R_{VC}$  Internal is the value of R102 measured in step 4 (Kilohms).  
 $I_b$  is the actual control current.  
 $\Delta E_o$  functions as voltage headroom to allow full scale from the front panel control.
6. Calculate the CONTROL RATIO as  $1/I_b$  (Kilohms/Volt using the value of  $I_b$  (mA) calculated in step 5.
7. Use the calculated values of  $I_b$  and CONTROL RATIO for all procedures of Section III.

As an example, referring to the Procedure: Precision Programming Ratio Adjustment, PAR. 3-16, step c, instead of  $R_{VC} = 5K$  Ohms, use  $R_{VC} = 5 (1/I_b)$  (in Kilohms) in order to obtain an output voltage of 5V.

- 3-14 Again referring to equation (3), we see that if  $R_{VC} = 0$  (shorted out), the output voltage should be zero. A small negative offset voltage (in the millivolt range) exists however under this condition at the output.
- 3-15 Both inaccuracies, the slightly larger control current ( $I_b$ ) and the small negative offset voltage may be adjusted by means of the built-in controls to provide a linear and precise programming ratio.
- 3-16 PROCEDURE, PRECISION PROGRAMMING RATIO ADJUSTMENT (Refer to FIG. 3-5).

- a) Equipment Required:

- 1) Precision digital or differential voltmeter (M1).
- 2) Precision resistor, accuracy comparable to M1. The value is not important, but must be known. For very 1000 ohms, 1 volt will appear across M1. ( $R_{VC}$ ).
- 3) Single pole, single throw switch (S1).

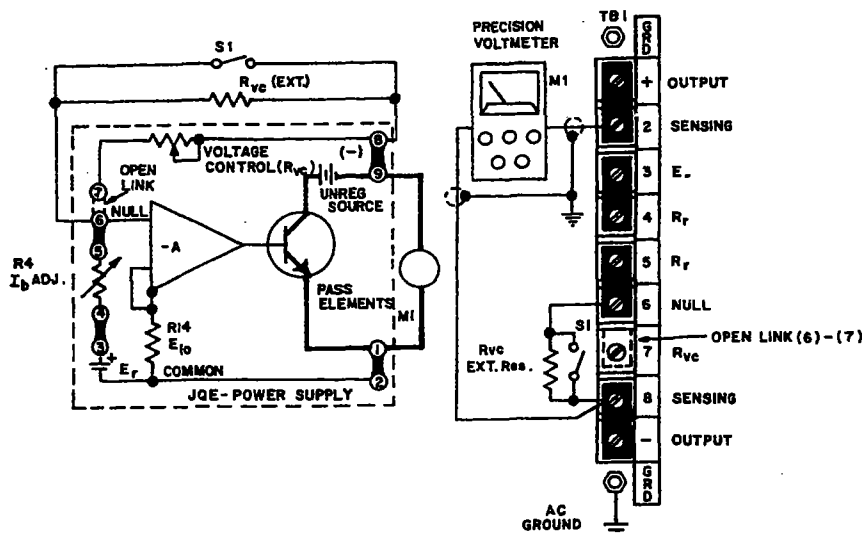

FIG. 3-5 CONNECTIONS FOR PRECISION PROGRAMMING RATIO ADJUSTMENT

- b) Connect calibration set-up as shown in FIG. 3-5 and connect the JQE power supply to the a-c power line.
- c) With S1 "open", and  $R_{VC} = 5K$  ohms for example, approximately 5 volts will be read-out on M1. Adjust " $I_b$  Adj." (control current calibration, R13, see FIG. 2-1 for location) until exactly 5 volts are read-out on M1.
- d) Close S1 and note deviation from zero on M1 (approx. 2 to 8 mV negative). Adjust " $E_{i0}$  null" (zero adjustment, R11, see FIG. 2-1 for location) until exactly zero volts are read-out on M1.
- e) Open S1 and check the 5 volt reading. Repeat "c" and "d", as necessary to achieve the desired accuracy. FIG. 3-6 below shows graphically how the programming ratio can be precision adjusted.

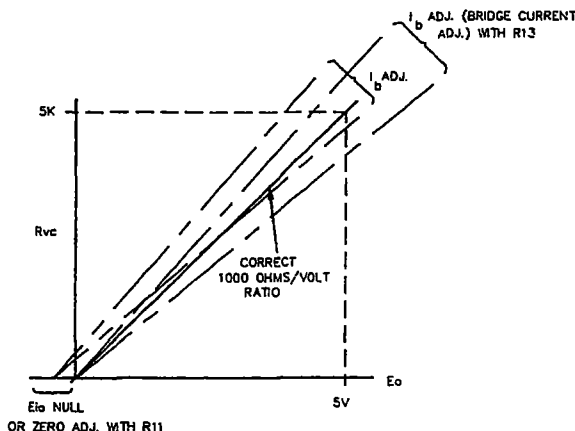

FIG. 3-6 ESTABLISHING PROGRAMMING LINEARITY

### 3-17 GENERAL RULES FOR REMOTE PROGRAMMING

3-18 All remote programming applications require the observance of a few basic rules to insure proper functioning of the power supply in the particular mode of operation selected. These rules should be remembered before each application and especially if malfunctioning of the programming set-up is experienced.

- 1) **GROUNDING.** Ground loops due to multiple and indiscriminate grounding of various equipment are the cause for the majority of complaints about "high ripple or noise". They can be easily avoided by grounding the power supply output-load circuit at **one single point**, to which all shielded cables and equipment cases are connected. Frequently, high ripple is introduced by programming-sources or instruments used at the input (null junction of the d-c error amplifier), although all grounding rules have been observed. This may be due to the external instrument's or source's close coupling to the a-c line. In such cases, isolation (i.e. battery operated devices) is the only answer. It must also be remembered, that input and output of the power supply are "common", so that if the output is not grounded, the input source must be isolated for the maximum output voltage to be programmed, plus the amount of voltage the common is "off ground".



### General Rules for Remote Programming (Cont'd)

- 2) **CONNECTIONS.** All external connections, especially those at the screw-terminals on the rear barrier strip, must be tight. Serious malfunctions may be caused by open feedback loops or other open programming connections.
- 3) **INPUT SOURCES.** If specified performance is expected using remote programming, external input or reference sources must have specifications equal to or better than that of the power supply.
- 4) **PROGRAMMING RESISTORS.** Programming resistors should be high-quality wirewound or metal-film units with temperature coefficients of 20 parts per million or better. Their wattage rating must be at least ten times the actual power dissipated. Although the control current through these resistors is only 1 mA, high peak currents may be generated when large voltage excursions are programmed. The peak currents can equal the magnitude of the change in output voltage, divided by the final resistance of the programming resistor. (If, for example, the voltage step is from 50 volts to zero ( $\Delta E_o = 50$  V), and the final resistance of the programming resistor is  $\Delta R_{VC} = 2$  ohms,  $I_{peak} = 25$  A). The duration of the peak error current depends upon the size of the output capacitor of the JQE model.  $I_{peak}$  decays exponentially as the output voltage assumes the final value.

If step-switch devices are used in resistance programming, they must be of the "make before break" variety to avoid opening the feedback loop and thereby causing momentary large voltage excursions. Programming resistors must have a voltage rating at least equal to the maximum output voltage of the power supply.

### 3-19 OUTPUT VOLTAGE PROGRAMMING WITH EXTERNAL RESISTANCE

The output voltage of the JQE Power Supply may be controlled remotely by an external resistance, replacing the built-in voltage control resistance which will be disconnected at the rear barrier strip. The value of the programming resistance may be calculated by referring to the transfer function derived earlier (Eq. 1):

$$E_o = R_{VC} (E_r/R_r)$$

Since  $E_r/R_r = I_b$  (Eq. 2), it follows  $E_o = I_b \times R_{VC}$  (Eq. 3).

Referring to Equation (3), we see that since  $I_b$  is 1 mA in the JQE supplies and can be precisely adjusted as shown in paragraph 3-12, for every volt of output, 1000 ohms control resistance must be provided. This corresponds to a "Programming Ratio" of 1000 ohms per volt.

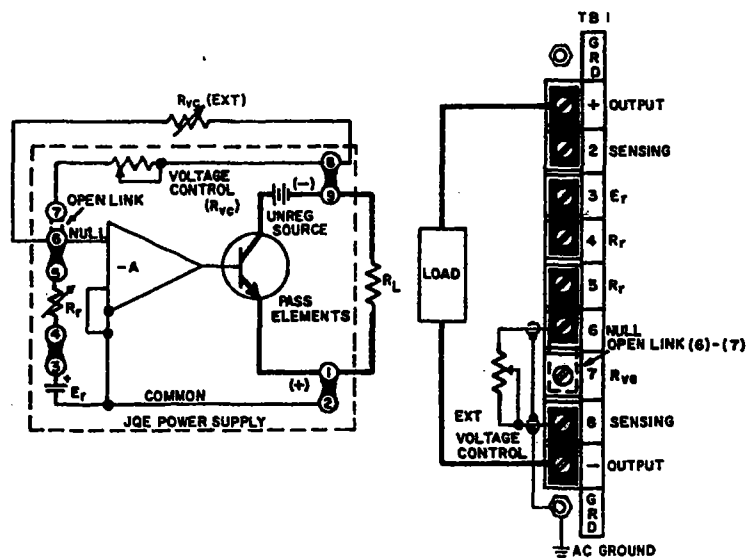

FIG. 3-7 REMOTE RESISTANCE PROGRAMMING

**3-20 PROCEDURE (Refer to FIG. 3-7)**

- a) Determine value of programming resistor(s) for output voltage desired.
- b) Using two-wire, shielded cable, connect the chosen resistors to terminals (6) and (8). Connect the shield to the "ground" terminal.
- c) The output voltage will vary from zero to  $(1 \text{ mA}) \times (R_{VC})$ , as  $R_{VC}$  is adjusted from zero to its maximum value.

**3-21 PROGRAMMING BY CONDUCTANCE**

**3-22** For special applications, the output voltage  $E_o$  can be adjusted by varying the control current. The relationship governing this type of programming is:

$$E_o = E_r(R_{VC})(G), \quad (\text{Eq. 4})$$

Where:  $G = 1/R_r + R_x = \text{programming conductance.}$

$E_o = \text{Output Voltage}$

$E_r = \text{Reference Voltage}$

$R_{VC} = \text{Voltage Control Resistance}$

$R_r = \text{Reference Resistance}$

$R_x = \text{Programming Resistor}$

or 
$$E_o = \frac{E_r}{R_r + R_x} (R_{VC})$$

Since  $E_r/R_r = I_b$  and  $E_o = I_b \times R_{VC}$ , with  $R_{VC}$  fixed, the output voltage varies proportionally to value of  $I_b$ . Changing  $I_b$  with the help of an additional resistor in series with  $R_r$  results in an inversely proportional change of  $I_b$ , since now:

$$I_b = E_r/(R_r + R_x)$$

This method of output voltage adjustment is therefore referred to as conductance programming.

**3-23** Conductance programming is a reciprocal function when analyzed in terms of resistance, but perfectly proportional: ( $E_o \propto 1/R_x$ )

Conductance programming can be very useful, especially over a limited range of output voltage. Another distinctive advantage of this type of programming is the "built-in" safety feature. Should the programming circuit open accidentally, the programming resistance becomes infinite, the conductance is zero, and consequently, the output voltage becomes zero.

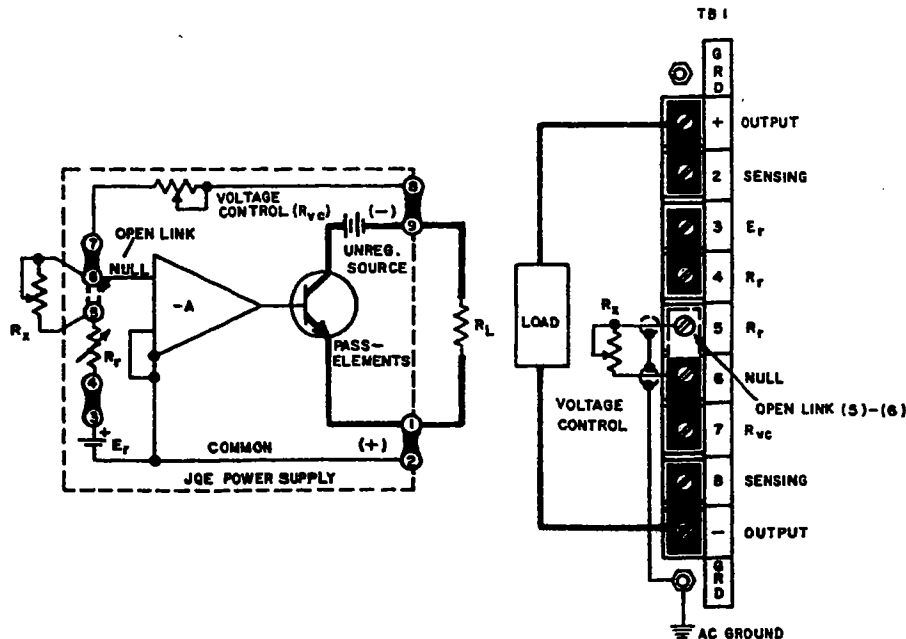

FIG. 3-8 REMOTE CONDUCTANCE PROGRAMMING

### 3-24 PROCEDURE (Refer to FIG. 3-8)

Example:  $E_o$  desired = 3 to 5 volts.

- a) Select  $R_{VC}$  for maximum desired output voltage  $E_o$ .

$$R_{VC} = E_o / I_b, R_{VC} = 5V / 1 \text{ mA} = 5K \text{ ohms.}$$

- b) A change of  $E_o$  to 3 volts requires a control current change of:

$$\Delta I_b = \Delta E_o / R_{VC} = 2 \text{ volts} / 5K \text{ ohms} = 0.4 \text{ mA}$$

- c) Since  $I_b = E_r / R_r = 1 \text{ mA}$ , the additional resistance needed is:

$$I_b (R_r + R_x) = E_r, R_x = E_r / I_b - R_r \text{ or } R_x = 6 \text{ volts} / 0.6 \text{ mA} - 6K = 4K \text{ ohms.}$$

A 4K ohm, WW, low T.C. potentiometer in series with  $R_r$  will change the output voltage from 3 to 5 volts when varied from zero to 4K ohms.

**NOTE:** A word of caution may be in order in regard to the changing of the control current. The 1 mA value has been selected for maximum stability in the zener reference circuit. A large departure from this value is not advisable. If a  $\pm 50\%$  change in  $I_b$  is not sufficient to achieve the desired voltage swing, an external reference supply can be used.

### 3-24A MAXIMUM OUTPUT CURRENT ADJUSTMENT.

**3-24B** This adjustment serves as a calibration for the range of the front panel Current Limit Control. The " $I_{o \text{ max. adj.}}$ " (R12) is located on the printed circuit board (Refer to FIG. 2-1). It is factory set, so that the front panel control covers an output current range of 10-105% of the maximum rated output current. Re-adjustment of the " $I_{o \text{ max. adj.}}$ " control is needed only if a component in the current limit circuitry must be replaced or, if the range of the front panel control is to be restricted. A convenient way to make the adjustment is as follows:

- Load the output of the supply to draw the maximum of 105% of rated output current with the front panel Current Limit Control fully clockwise. Monitor the output voltage with an oscilloscope, having a vertical sensitivity of at least 0.1 mV/cm.
- Observe the oscilloscope. Current limiting is indicated by a sharp increase in output ripple. Locate the " $I_{o \text{ max. adj.}}$ " control and turn slowly until limiting occurs at the point required. Clockwise adjustment will increase the maximum output current range, while counter-clockwise adjustment will decrease the range. **DO NOT ADJUST TO MORE THAN 105%  $I_{o \text{ max.}}$**  Although this might be possible due to component tolerances, malfunction of the power supply will be caused by exceeding the rated maximum output current.

### 3-25 REMOTE PROGRAMMING WITH EXTERNAL CONTROL VOLTAGE

**3-26** The output voltage of the power supplies in the JQE group may be controlled by an external, variable voltage source, which supplies the necessary control current, formerly delivered by the (now disconnected) internal, fixed reference source. This mode of operation is termed "Voltage Programming". It can be mathematically expressed by referring to basic equation (1):

$$E_o / E_r = R_{VC} / R_r \quad (\text{Eq. 1})$$

$$\text{Solving for } E_o = E_r R_{VC} / R_r \quad (\text{Eq. 5})$$

**3-27** As seen from the expression (Eq. 5), if the ratio  $R_{VC} / R_r$  (which represents the closed loop gain of the system) is held constant,  $E_o$  will vary linearly with  $E_r$ , the external programming voltage. The above expression (Eq. 5) is seen to be the transfer function for an operational amplifier in the inverting configuration. The voltage programmed power supply does in fact become a unipolar power amplifier with very high power gain but with limited frequency response. (Refer to FIG. 3-9). The limited frequency response is largely due to the effect of the output capacitor ( $C_o$ ), acting as a low-pass filter and preventing the output voltage ( $E_o$ ) from varying rapidly. The output voltage may be varied over the full range, bounded on the high end by the maximum rated value. A practical example to illustrate component selection for remote control by voltage is given in paragraph 3-28.

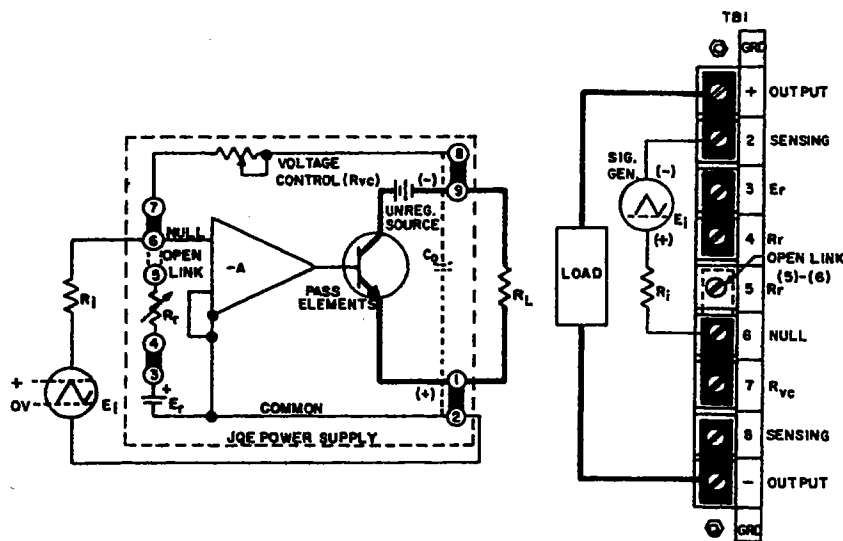

FIG. 3-9 JQE 1/4 Rack IN THE OPERATIONAL AMPLIFIER MODE.

3-28 Example: A Kepco Model JQE 36-3M is to be voltage programmed over its full range (0 to 36V) by a triangular, positive increasing source with a peak output voltage ( $E_1$ ) of 2 volts, which is able to deliver at least 1 mA control current. Since the required voltage gain is:  $E_o/E_1 = 36/2 = 18$ , the ratio  $R_{VC}/R_i$  must also equal 18. If the internal voltage control is retained, in this case, since  $R_{VC} = 40K$  ohms,  $R_i$  must equal  $40K/18 = 2.22K$  ohms. FIG. 3-9 shows the JQE Power Supply as an operational amplifier and the necessary rear barrier connections for this mode of operation. As the input source varies from 0 to 2V, the JQE output voltage will change from 0 to 36 volts.

### 3-29 CONSTANT CURRENT OPERATION

3-30 The JQE power supply can be set up to deliver constant current by the addition of an external sensing resistor and a current control. In the constant current operating mode, the voltage comparison bridge is interconnected with an external current sensing resistor,  $R_s$ , and a current control,  $R_{CC}$ , (as shown in FIG. 3-10), while the voltage control ( $R_{VC}$ ) is disconnected. The voltage comparison bridge, instead of monitoring the *output voltage* as before, is now stabilizing the *sensing voltage* which is proportional to the *output current*. In this way, an adjustable constant load current is obtained. Characteristic of the constant current supply is its ability to change its *output voltage* automatically in order to maintain a *constant current* through a range of possible load resistance. The range of output voltage that the supply can deliver and simultaneously maintain constant current, is referred to as the "COMPLIANCE VOLTAGE". For each JQE model, it is equal to its rated output voltage.

3-31 The current sensing resistor  $R_s$  is chosen to develop a 1 volt drop at the maximum desired current.  $R_s$  is calculated by dividing this current into one volt. The value of  $R_s$  is not critical and can be the nearest standard resistance available. Several facts should be kept in mind however, when choosing  $R_s$ . A compromise must be made between a large and small value. While a large value is desirable for good current stabilization, it is less desirable in view of the power dissipated across it. It must be remembered that all the load current is flowing through  $R_s$  and the comparison amplifier input is connected across it. It is therefore vital that all extraneous changes across  $R_s$ , i.e. resistance change due to temperature, are kept to a minimum. A high quality, low T.C. (20ppm) resistor, at least ten times the actual wattage needed, is therefore strongly recommended. In practice,  $R_s$  is usually selected for a 1 volt sample at the maximum output current desired. If more than a 50:1 ratio of output is needed, several values of  $R_s$  should be selected and switched in or out as required.

3-32 The current control resistor,  $R_{CC}$ , is chosen on the basis of the control ratio of the Kepco comparison bridge, and  $V_s$ , the maximum voltage across  $R_s$ . If  $R_s$  was selected for 1 volt drop, then  $V_s = 1$  volt and  $R_{CC} = V_s$  times (control ratio), or

$$R_{CC} = 1 \text{ volt} \times 1000 \text{ ohm}/1 \text{ volt} = 1000 \text{ ohms.}$$

A high quality, low T.C. (20ppm) resistor is recommended for  $R_{cc}$ . If  $R_{cc}$  is *not* selected for 1 volt drop, the control ratio will of course differ from the standard 1000 ohm/volt and  $R_{cc}$  must be recalculated for the new control ratio.

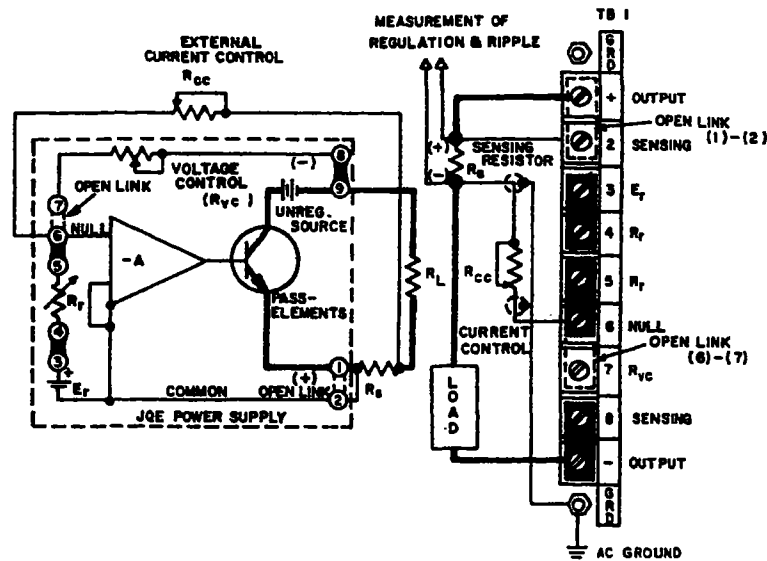

FIG. 3-10 CONSTANT CURRENT OPERATING MODE

### 3-33 PROCEDURE (Refer to FIG. 3-10)

The actual component selection for current stabilization is perhaps best shown by a practical example. A JQE 100-1M is to be set up for stabilized current output from 6mA to 300mA. (1:50 ratio).

- a)  $R_s$  is chosen by:  $R_s = 1 \text{ volt}/0.3\text{A} = 3.33 \text{ ohm}$ .  
 $P_{\text{diss}} = V_s \times I_{\text{max}} = 1 \text{ volt} (0.3\text{A}) = 0.3 \text{ watts}$ .  
 Three 10 ohm, 1 W, wire-wound resistors, connected in parallel, will be satisfactory.
- b) The control resistance  $R_{cc}$  is found by calculating its limits:  
 $R_{cc} (\text{max.}) = V_s \text{ max. (control ratio)} = 1 \text{ V} (1000 \text{ ohms/V}) = 1000 \text{ ohms}$ .  
 $R_{cc} (\text{min.}) = V_s \text{ min. (control ratio)} = 20\text{mV} (1000 \text{ ohms/V}) = 20 \text{ ohms}$ .  
 As  $R_{cc}$  is therefore varied from 20 ohms to 1000 ohms, the output current will vary from 6 to 300mA. The compliance voltage will change in the same ratio (50:1), its instantaneous value depending on the instantaneous load resistance.
- c) The full output current range (1mA to 1A = 1:100) could be covered if two separate sensing resistors were to be calculated and switched into the sensing circuit. One would cover a range of 50:1, (1mA to 50mA) and the other a range of 50mA to 1A (1:20) and both would be calculated on the basis of a 1 volt sample at maximum current:
  - a)  $R_s^1$  (for 1mA to 50mA) =  $1\text{V}/50\text{mA} = 20\Omega$  (0.5 watt).
  - b)  $R_s^2$  (for 0.05A to 1A) =  $1 \text{ V}/1\text{A} = 1\Omega$  (10 watt).

### 3-34 SERIES OPERATION

**3-35 GENERAL.** Kepco JQE Power Supplies can be series-connected for increased voltage output, provided the specified limits on voltage to chassis are not exceeded. When series-connected, the supplies should be protected by means of a semi-conductor diode across the output terminals of each power supply, as shown in FIG. 3-11. The peak inverse rating of these diodes must be at least as large as the output voltage of the supply to which they are connected. The continuous current rating of the diodes should be at least as great as the maximum output current of the interconnected supplies.

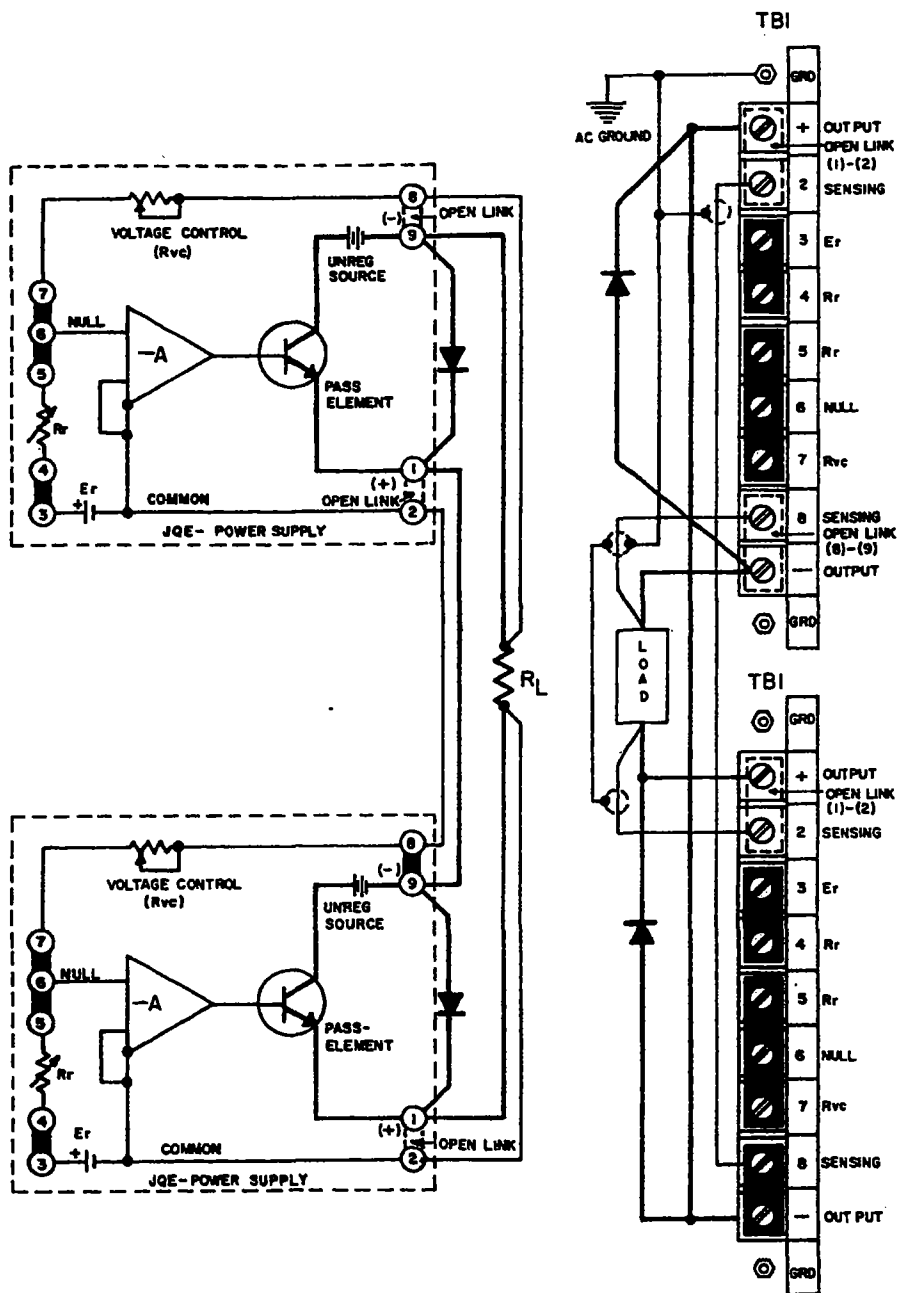

FIG. 3-11 AUTOMATIC SERIES CONNECTION OF JQE POWER SUPPLIES

**3-36 PROCEDURE**

- a) Connect load as shown in FIG. 3-11. Keep voltage drop in load wires as low as practical by using heavy gauge wire.
- b) Connect protective diodes across respective output terminals.
- c) Remove jumper links as shown and connect error sensing leads. These leads carry negligible current and should be approximately #18 gauge wire.
- d) Turn supplies "on" and adjust voltage on either control as required.

**3-37** An alternate method of series-connecting two or more power supplies is shown in FIG. 3-12. The basic difference between the "Automatic" series connection, shown in FIG. 3-11, and the "Master-Slave" connection (FIG. 3-12) is that with the former connection the outputs of both supplies may be controlled or programmed individually, while with the latter method only the "Master" supply is controlled, while the "Slave" supply follows the command of the "Master" in a ratio which may be pre-determined by the user. The "Master-Slave" series connection is therefore often termed an "Automatic Tracking" configuration.

3-38 The principle of operation of the "Master-Slave" series connection is as follows:

As seen from FIG. 3-12, the reference voltage of the "Slave" supply is disconnected and its input (null junction) is connected (via  $R_t$ ) to the output of the "Master" supply. Since the control current for the "Slave" supply is thereby derived from the "Master", the "Slave" output is thus completely dependent on the "Master" supply output:

$$E_{os} = E_{om} (R_{vcs}/R_t)$$

Where:  $E_{om}$  = Output Voltage, Master  
 $E_{os}$  = Output Voltage, Slave  
 $R_t$  = Tracking Resistor  
 $R_{vcs}$  = Voltage Control Resistor, Slave.

As seen from the equation, if the tracking resistor ( $R_t$ ) is made equal in value to the voltage control resistor of the "Slave" ( $R_{vcs}$ ), a tracking ratio 1:1 is achieved, and the output of the "Slave" will equal that of the "Master". If a single load is connected to the series combination (FIG. 3-12), twice the "Master" output is applied to it. If separate loads are connected, identical voltages are applied to the individual loads. The ratio  $E_{os}/E_{om}$  can be readily changed if the application so requires by simply changing either  $R_{vcs}$  or  $R_t$ .

### 3-39 PROCEDURE

- Connect load(s) as shown in FIG. 3-12.
- Remove jumpers as shown and connect error sensing leads if required.
- Turn supplies "on" and adjust output on the "Master" supply as required.

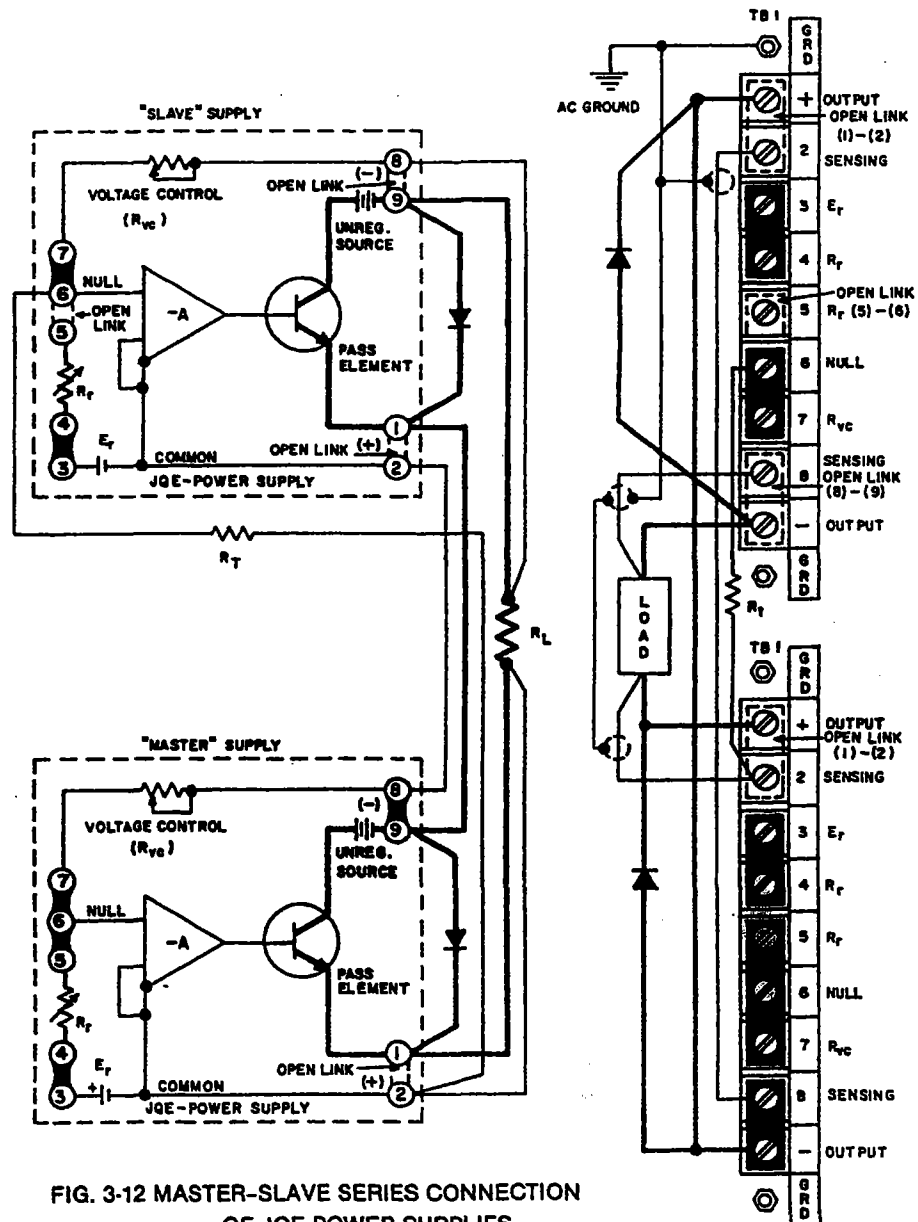

FIG. 3-12 MASTER-SLAVE SERIES CONNECTION OF JQE POWER SUPPLIES

### 3-40 PARALLEL OPERATION

3-41 GENERAL. Kepco JQE Power Supplies can be parallel connected for increased load current output. As in the previously described series connections, an "Automatic" or a "Master-Slave" connection method can be chosen. The basic difference between the two suggested methods is the manner in which the output is controlled. The "Automatic" method requires individual output control from each power supply, while with the "Master-Slave" method, single control is exercised from the "Master" supply. For either method, some general rules apply which should be observed in paralleling power supplies:

- 1) Connect only supplies with identical compliance voltage range.
- 2) Error sensing (from either supply) may be used as shown in the diagrams. Close barrier-strip links if this is not desired.
- 3) Load wires should be as short as practicable. Select the wire gage as heavy as possible and twist tightly. Approximately equal lengths of wire should be used.
- 4) Common a-c power turn-on for all supplies is recommended.

3-42 AUTOMATIC PARALLEL CONNECTION. Each supply is set approximately to the desired output voltage with its respective Current Limit Control at factory adjusted value (105%  $I_{O\ max.}$ ). After paralleling the two power supplies, one of the supplies (supply #1) will inherently be at a slightly higher output voltage than the other (supply #2). Consequently, supply #1 will deliver all the load current up to the setting of its Current Limit Control and enter the Current Limit Mode of operation. As the load is increased beyond the limit of supply #1, supply #2 takes over and delivers the additional current, operating in the Voltage Mode. The Current Limit Control setting of supply #1 can now be decreased, so that approximately equal current sharing is obtained. FIG. 3-13 shows in form of a diagram, how the two supplies operate in parallel, with their respective Current Limit Control at the factory adjusted value (105%  $I_{O\ max.}$ ). From the diagram, we see that load current steps greater than the current delivered by supply #2 will introduce an error in load effect measurement. This error is due to the difference voltage between supply #1 and supply #2.

### CAUTION

When using the "AUTO-PARALLEL" method, *avoid turning the voltage control of only one supply close to zero*. This precaution is necessary to prevent damaging currents in the voltage control resistor, as its limiting resistance is lowered.

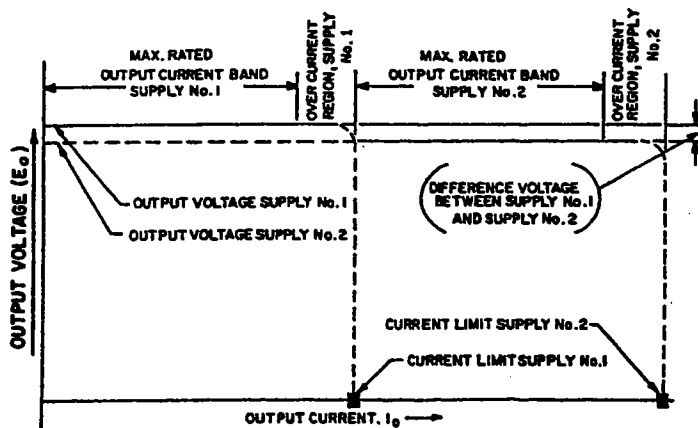

FIG. 3-13 PARALLEL OPERATION, JQE SUPPLIES.

### 3-43 PROCEDURE (Refer to FIG. 3-14)

- a) Connect units as shown in FIG. 3-14. Open SW-1 and connect to line.
- b) Adjust both units to the approximate output voltage desired.
- c) Close SW-1. Observe load current meters M1 and M2. Adjust Current Limit Control on the unit showing the higher current on its load current meter. Turn Current Limit Control counter-clockwise until currents on M1 and M2 are approximately equal.



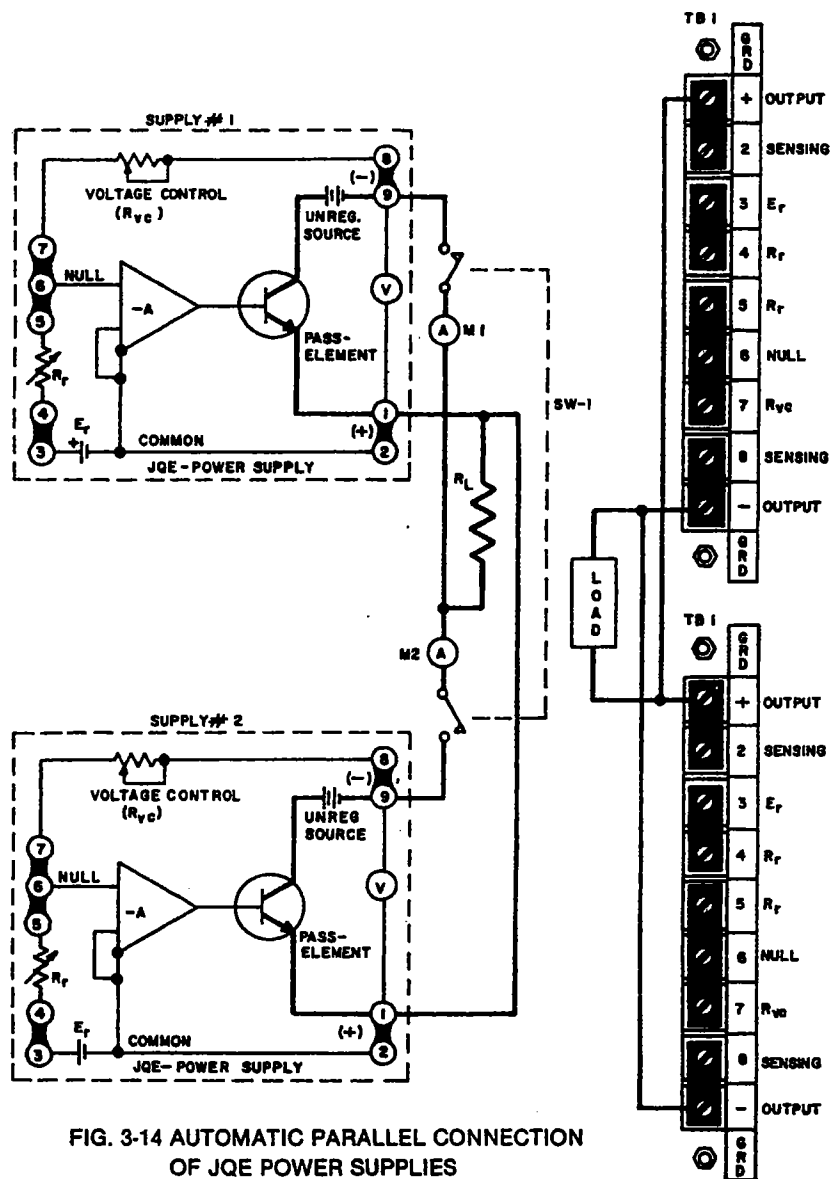

FIG. 3-14 AUTOMATIC PARALLEL CONNECTION OF JQE POWER SUPPLIES

**3-44 MASTER-SLAVE PARALLEL OPERATION:** Kepco Power Supplies may be paralleled if the output current from a single supply is not sufficient for the application at hand. With the parallel connection shown in FIG. 3-15, the total output current of the parallel supplies may be controlled from a single "Master" supply. To operate the parallel supplies in the "Master-Slave" connection, sensing resistors of equal value must be selected ( $R_{s1}$ ,  $R_{s2}$  in FIG. 3-15) such that the voltage drop across them is about 0.1 to 0.25 volts at the output current of interest. The *sum* of the voltage drops across the load wire with the sensing resistors in series should *never exceed 0.5 volts* at the maximum desired operating current. If sensing resistors of the proper value are not available, the resistance of the load wires may be sufficient to establish the necessary voltage drops. In this case, the load wires should be trimmed such that *equal voltage drops* are established in the load wire from the "Master" and that from the "Slave" supply. Load wires should in general be of as heavy a wire gauge as practicable. Twisting of the load wires, as well as of the error sensing leads from the "Master" supply (although *not* shown in FIG. 3-15) is recommended.

**3-45 PROCEDURE FOR "MASTER-SLAVE" PARALLEL CONNECTIONS**

- a) Select external current sensing resistor ( $R_{s1}$ ,  $R_{s2}$ ) as described.
- b) Connect supplies as shown in FIG. 3-15, keeping load and error sensing leads as short as possible. Use shielded wire for the connection from terminal (2) of the "Master" to terminal (6) of the "Slave" unit.
- c) Connect supplies to common a-c power line and use common power switching.
- d) After turn-on, output voltage can be adjusted on the Voltage Control of the "Master" supply and operation can commence.

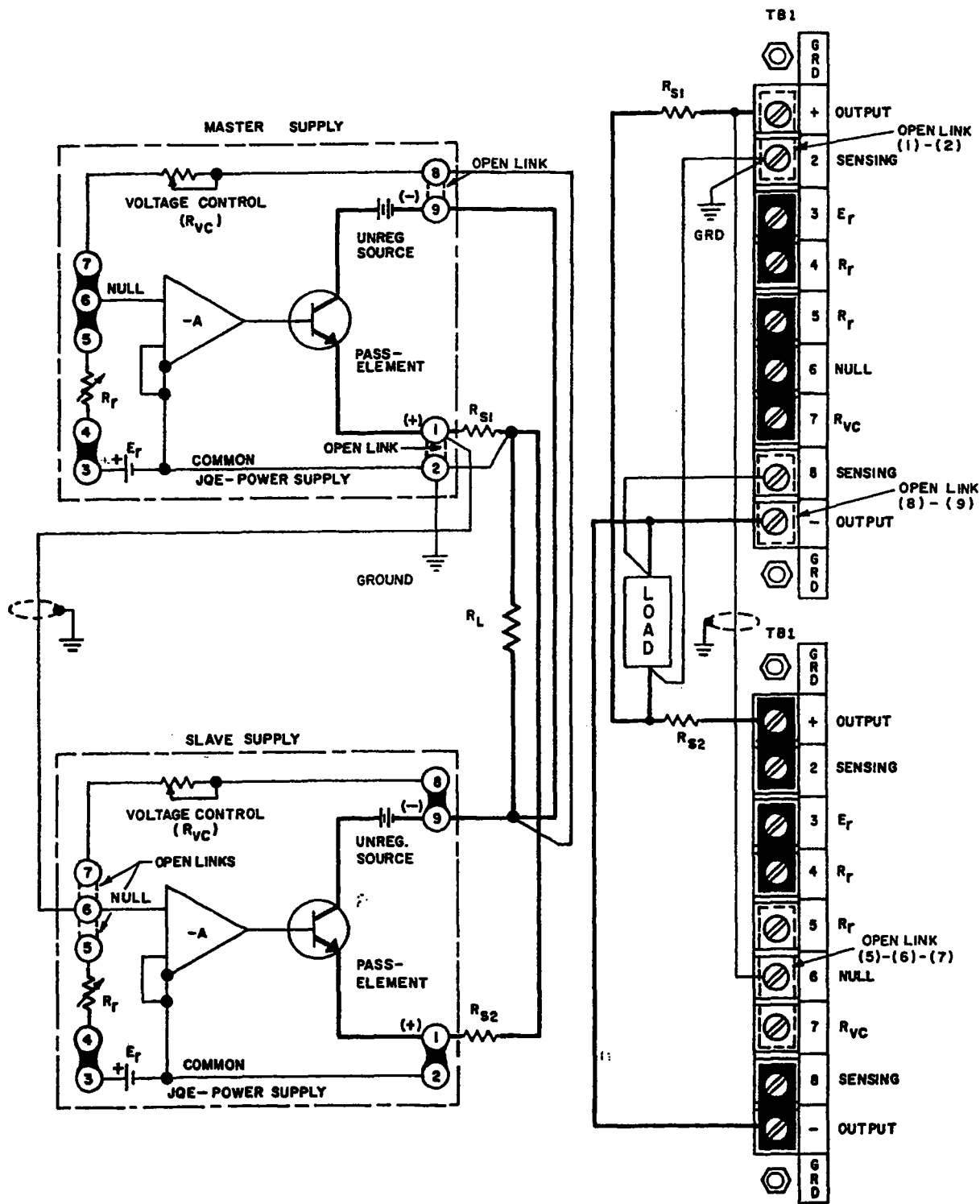

FIG. 3-15 MASTER-SLAVE PARALLEL CONNECTION OF JOE POWER SUPPLIES