

**COMPACT
POWER SUPPLY**

Model JOE 6-22 (M)

Serial No.

I N S T R U C T I O N M A N U A L

The KEPCO equipment described in this instruction manual is of proprietary design, and is licensed under the United States patent rights of Forbro Design Corp.

The contents of this instruction manual are copyrighted. Reproduction of any part may only be made with the specific written permission of KEPCO, Inc. Data subject to change without notice.

© KEPCO, Inc. 1969

KEPCO, INC. • 131-38 SANFORD AVENUE • FLUSHING, N.Y. 11352 • (212) 461-7000 • TWX # 710-582-2631 • Telex: 12-6055 • Cable: KEPCOPOWER NEWYORK



U
V
W

U
V
W

TABLE OF CONTENTS

PARAGRAPH		PAGE
SECTION I – INTRODUCTION		
1-1	Scope of Manual	1-1
1-3	General Description	1-1
1-9	Accessories	1-1
1-10	Specifications, General	1-1
1-11	Specifications, Electrical	1-2
1-12	Specifications, Performance	1-3
1-13	Specifications, Physical	1-4
SECTION II – INSTALLATION		
2-1	Unpacking and Inspection	2-1
2-3	Terminations	2-1
2-4	AC Input Requirements	2-2
2-6	Cooling	2-2
2-8	Preliminary Check-Out	2-2
2-10	Installation	2-5/2-6
2-12	Grounding	2-5/2-6
SECTION III – OPERATION		
3-1	Load Connection without Error Sensing	3-1
3-2	Load Connection with Error Sensing	3-1
3-3	Kepeco Power Supply Circuit with Comparison Bridge	3-2
3-4	Connections for Precision Programming Ratio Adjustment	3-4
3-5	Establishing Programming Linearity	3-4
3-6	Remote Resistance Programming	3-6
3-7	Remote Conductance Programming	3-7
3-8	The Power Supply in the Operational Amplifier Mode	3-8
3-9	Constant Current Operating Mode	3-9
3-10	Automatic Series Connection	3-12
3-11	Master-Slave Series Connection	3-13
3-12	Parallel Operation	3-15
3-13	Basic Parallel Connection	3-16
3-14	Master-Slave Parallel Connection	3-17/3-18
SECTION IV – THEORY OF OPERATION		
4-1	Simplified Diagram Discussion	4-1
4-5	Circuit Description	4-2
SECTION V – MAINTENANCE		
5-1	General	5-1
5-3	Disassembly	5-1
5-4	Internal Adjustment Procedures	5-2
5-8	Installation and Adjustment of the "Zero" Control	5-2
5-11	Trouble Shooting	5-3
5-16	Power Supply Measurements	5-4
SECTION VI – ELECTRICAL PARTS LIST AND DIAGRAMS		
6-1	General	6-1/6-2
6-3	Ordering Information	6-1/6-2

LIST OF ILLUSTRATIONS

FIGURE		PAGE
1-1	Kepeco Half-Rack JQE Power Supply, Front View (Typical)	-iii-
1-2	Kepeco Half-Rack JQE Power Supply, Rear View (Typical)	-iv-
1-3	Mechanical Outline Drawing	1-5/1-6
2-1	Location of Internal Adjustments	2-1
2-2	Conversion to 230V AV Operation	2-2
2-3	Controls and Terminations, JQE Half-Rack Models, Front	2-3
2-4	Rear Terminations, JQE Half-Rack Models	2-4
3-1	Load Connection without Error Sensing	3-1
3-2	Load Connection with Error Sensing	3-1
3-3	Kepeco Power Supply Circuit with Comparison Bridge	3-2
3-4	Connections for Precision Programming Ratio Adjustment	3-4
3-5	Establishing Programming Linearity	3-4
3-6	Remote Resistance Programming	3-6
3-7	Remote Conductance Programming	3-7
3-8	The Power Supply in the Operational Amplifier Mode	3-8
3-9	Constant Current Operating Mode	3-9
3-10	Automatic Series Connection	3-12
3-11	Master-Slave Series Connection	3-13
3-12	Parallel Operation	3-14
3-13	Basic Parallel Connection	3-15
3-14	Master-Slave Parallel Connection	3-16
4-1	Simplified Schematic with Rear Connection Detail	4-1
5-1	Disassembly, JQE Half-Rack Models	5-1
5-2	Installation of "E _{IO} Null" (Zero) Control	5-2
5-3	Connections for Power Supply Measurements	5-5/5-6
6-1	Component Location, Chassis and Auxiliary Boards	6-13
6-2	Component Location, Amplifier and VP Assembly	6-14
6-3	Main Schematic	6-15/6-16

LIST OF TABLES

TABLE		PAGE
1-1	JQE (Half-Rack) Group, Specifications-General	1-2
1-2	JQE (Half-Rack) Group, Specifications-Electrical	1-3
2-1	Internal Adjustments	2-1

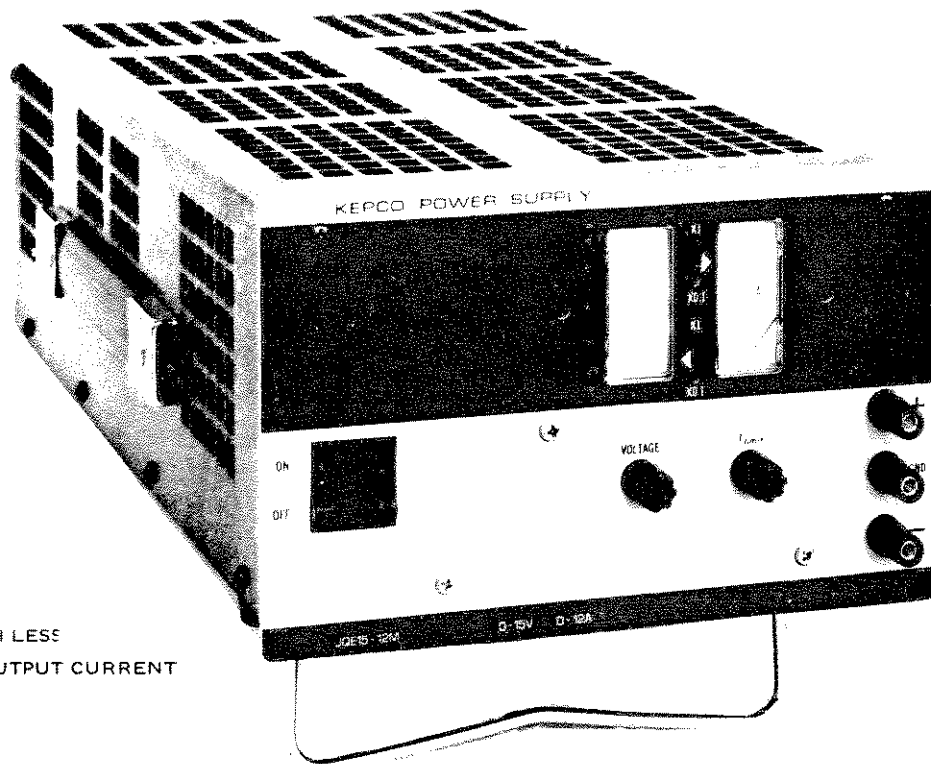

a) MODELS WITH LESS
THAN 15A DC OUTPUT CURRENT

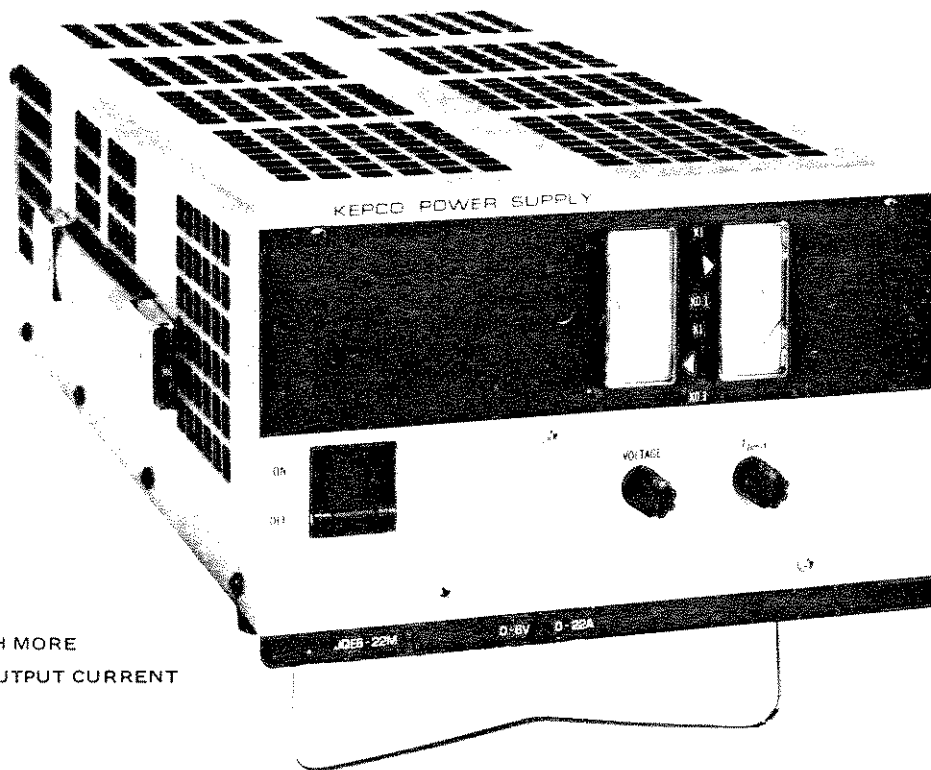

b) MODELS WITH MORE
THAN 15A DC OUTPUT CURRENT

FIG. 1-1 JQE HALF-RACK POWER SUPPLY, TYPICAL FRONT VIEWS

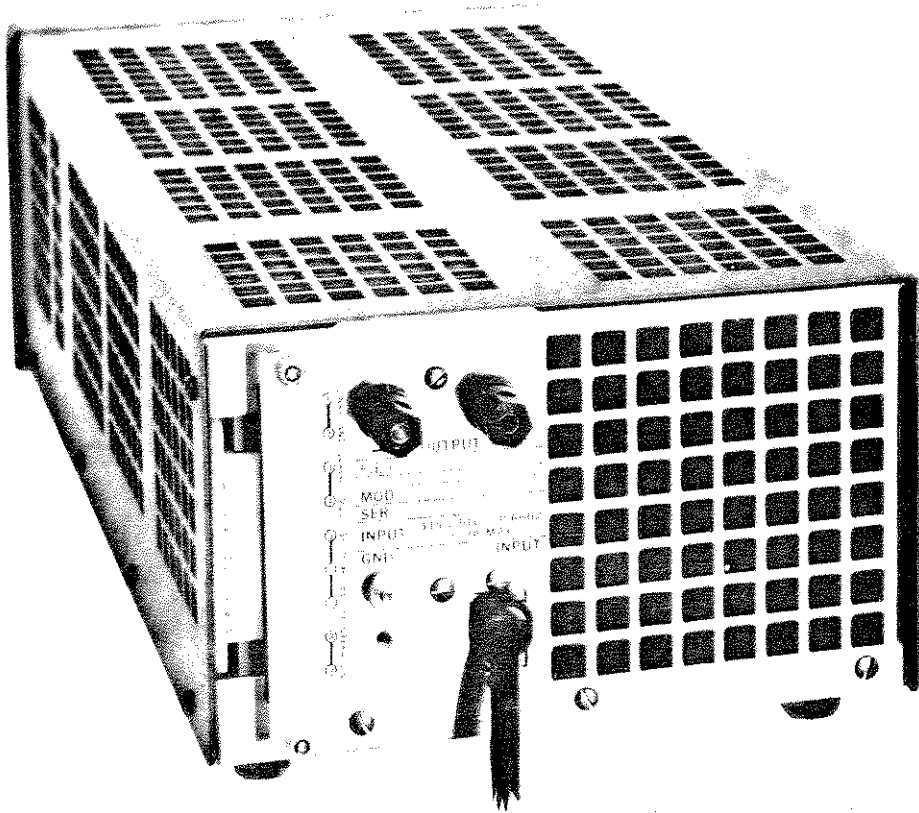

a) MODELS WITH LESS THAN 25A DC OUTPUT CURRENT

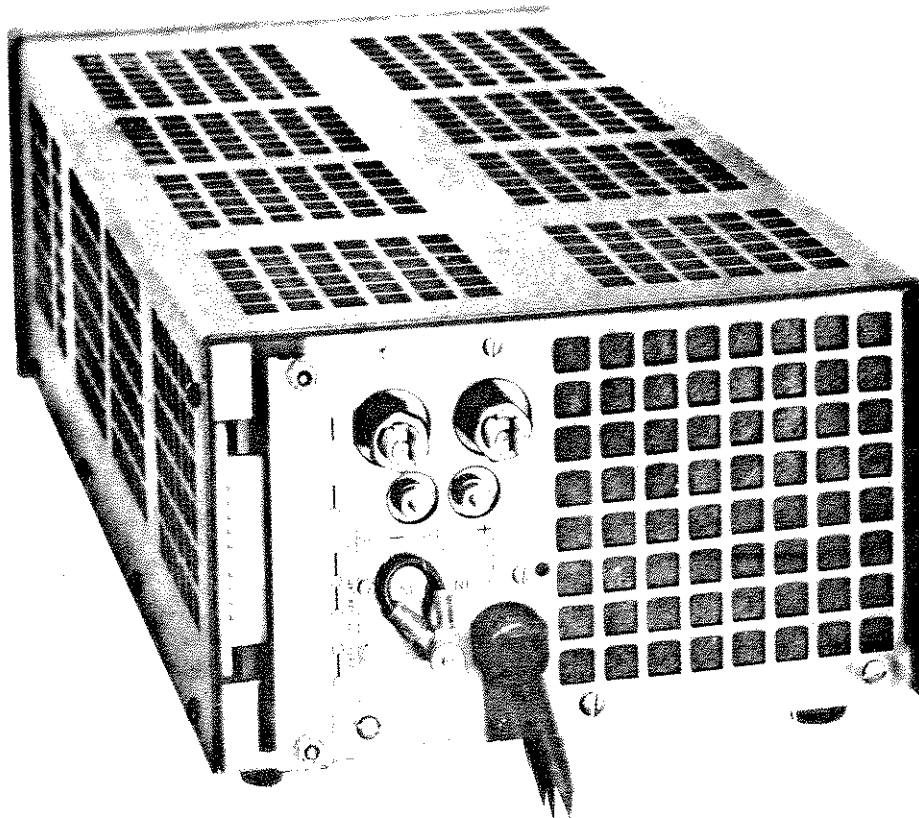

b) MODELS WITH 25A DC AND 45A DC OUTPUT CURRENT

FIG 1-2 HALF-RACK POWER SUPPLY, TYPICAL REAR VIEWS

SECTION I – INTRODUCTION

1-1 SCOPE OF MANUAL

- 1-2 This manual contains instructions for the installation, operation and maintenance of the Kepco JOE "HALF-RACK" Series of Power Supplies.

1-3 GENERAL DESCRIPTION

- 1-4 Kepco Series JOE Power Supplies are general purpose, precision regulated voltage sources in the "half-rack" configuration. JOE Power Supplies feature full range voltage control and current limit adjustment by means of multi-turn front panel controls. JOE power supplies have linear, full-dissipation series-regulators (NPN) driven by an integrated circuit operational amplifier. A sharp current-limit circuit renders the power supply completely short-circuit proof. JOE power supplies may be readily converted to provide constant current by the addition of an external sensing resistor and a "current control." The output of the JOE power supply is completely programmable. All necessary connections are available on terminals at the rear barrier-strip.
- 1-5 The compact design of the Kepco JOE "HALF-RACK" Series was made possible by a unique heat sink design of exceptional efficiency in combination with highly reliable low-noise fans. JOE power supplies feature all-silicon design with conservatively rated components for added reliability.
- 1-6 JOE power supplies are identical in their mechanical dimensions (Refer to FIG. 1-3) and in their electrical specifications, except as noted in TABLE 1-1.
- 1-7 OPTIONS. Optional features of Kepco Power Supplies are indicated by a letter following the model designation:
- JOE Power Supplies with suffix "E" are equipped with an "E_{IO} Null" adjustment, which allows exact zero calibration for precision programming applications.
 - JOE Power Supplies with suffix "M" are equipped with two dual range panel meters which permit simultaneous monitoring of the output voltage and output current. Meter range-switches allow for full scale reading of either 10% or 100% of the voltage and current outputs.
 - JOE Power Supplies with suffix "T" have special references which improve the temperature coefficient of the supply (see paragraph 1-11 for specifications).
 - JOE Power Supplies with suffix "VP" are equipped with an overvoltage protector. This electrical "crowbar" shorts the output through a silicon controlled rectifier (SCR) if the output voltage exceeds a preadjustable limit on the protector (see paragraph 1-12 for specifications).
 - JOE Power Supplies with suffix "Y" are equipped with a separate control-amplifier and additional programming terminals for remote control of the output current. Option "E" is included with the "Y" option models.
- 1-8 The main chassis frame of the power supply is constructed from cold-rolled steel, as is the perforated wrap-around cover. Front panel material is aluminum (Refer to FIG. 1-3 for finish).

1-9 ACCESSORIES

- RACK ADAPTOR (FOR TWO UNITS: KEPKO MODEL RA 24. Fits standard EIA rack dimensions.
- FILLER PANEL, to cover empty slot if RA-24 is used for one unit only: KEPKO MODEL RFP 24-2.
- RACK ADAPTOR PANEL: KEPKO MODEL RAP 24-2J for installing meterless models into RA 24.
- RACK ADAPTOR (FOR ONE 1/2-RACK UNIT AND THREE 1/6 RACK PLUG-in MODELS), KEPKO MODEL RA-32.

1-10 SPECIFICATIONS, GENERAL

- AC INPUT: 105 to 125V AC or 210 to 250V AC (selectable, refer to SECTION II), 50 to 65 Hz,* single phase. Refer to the table of general specifications (TABLE 1-1) for the AC input current for each model. Approximate power factor: 0.9.
- OPERATING TEMPERATURE RANGE: (-)20°C to (+)71°C (without derating of the output).

*Consult factory for operation on power line frequencies above 65 Hz.

- c) STORAGE TEMPERATURE: -40°C to $(+85^{\circ}\text{C})$.
- d) COOLING: High efficiency, single bearing fan, (permanently lubricated) with special low noise non-metal blade.
- e) ISOLATION: A maximum of 500 volts (DC or p-p) can be connected between chassis and either output terminal. The common mode current from output to ground is less than 5 micro amps rms, or 50 micro amps peak to peak at 115V AC, 60 Hz.

1-11 SPECIFICATIONS, ELECTRICAL

a) Refer to TABLE 1-1 and 1-2.

MODEL	dc OUTPUT RANGE		OUTPUT IMPEDANCE		MAX INPUT AMPS at 125 V ac
	VOLTS	AMPS	VOLTAGE MODE dc OHMS + SERIES L	CURRENT MODE ⁽³⁾ dc OHMS + SHUNT C	
JQE 6-22	0-6	0-22	$14 \mu\Omega + 0.5 \mu\text{H}$	$23 \text{k}\Omega + 5.8 \text{k}\mu\text{F}$	4.2
JQE 6-45	0-6	0-45	$7 \mu\Omega + 0.5 \mu\text{H}$	$11 \text{k}\Omega + 8 \text{k}\mu\text{F}$	9.0
JQE 15-12	0-15	0-12	$63 \mu\Omega + 0.5 \mu\text{H}$	$42 \text{k}\Omega + 300 \mu\text{F}$	4.0
JQE 15-25	0-15	0-25	$30 \mu\Omega + 0.5 \mu\text{H}$	$20 \text{k}\Omega + 4.5 \text{k}\mu\text{F}$	8.4
JQE 25-10	0-25	0-10	$125 \mu\Omega + 0.5 \mu\text{H}$	$50 \text{k}\Omega + 2.4 \text{k}\mu\text{F}$	5.3
JQE 25-20	0-25	0-20	$63 \mu\Omega + 0.5 \mu\text{H}$	$25 \text{k}\Omega + 4.3 \text{k}\mu\text{F}$	10.5
JQE 36-8	0-36	0-8	$225 \mu\Omega + 0.5 \mu\text{H}$	$62.5 \text{k}\Omega + 1.4 \text{k}\mu\text{F}$	6.0
JQE 36-15	0-36	0-15	$120 \mu\Omega + 0.5 \mu\text{H}$	$33 \text{k}\Omega + 3.6 \text{k}\mu\text{F}$	9.5
JQE 55-5	0-55	0-5	$550 \mu\Omega + 1 \mu\text{H}$	$100 \text{k}\Omega + 850 \mu\text{F}$	5.0
JQE 55-10	0-55	0-10	$275 \mu\Omega + 1 \mu\text{H}$	$50 \text{k}\Omega + 2.1 \text{k}\mu\text{F}$	9.0
JQE 75-3	0-75	0-3	$1.25 \text{m}\Omega + 1 \mu\text{H}$	$165 \text{k}\Omega + 850 \mu\text{F}$	4.0
JQE 75-8	0-75	0-8	$469 \mu\Omega + 1 \mu\text{H}$	$62.5 \text{k}\Omega + 1.2 \text{k}\mu\text{F}$	10.0
JQE 100-2.5	0-100	0-2.5	$2 \text{m}\Omega + 1 \mu\text{H}$	$200 \text{k}\Omega + 600 \mu\text{F}$	4.5
JQE 100-5	0-100	0-5	$1.25 \text{m}\Omega + 1 \mu\text{H}$	$100 \text{k}\Omega + 600 \mu\text{F}$	8.4
JQE 150-1.5	0-150	0-1.5	$5 \text{m}\Omega + 2 \mu\text{H}$	$330 \text{k}\Omega + 440 \mu\text{F}$	4.6
JQE 150-3.5	0-150	0-3.5	$2.2 \text{m}\Omega + 2 \mu\text{H}$	$140 \text{k}\Omega + 440 \mu\text{F}$	8.7

NOTE: Specifications for metered models (suffix "M") are identical.

TABLE 1-1 JQE (1/2 RACK) GROUP, SPECIFICATIONS

NOTE: Kepco has adopted new technical terms recommended by the International Electrotechnical Commission (IEC). These terms replace or supplement previously used expressions to avoid difficulties in translation and prevent erroneous interpretations at home and abroad.

In this instruction manual, Kepco discontinued the use of the specifications entitled "line regulation" and "load regulation." Instead, Kepco will follow the recommendation of the IEC and speak of the "Output Effects, caused by changes in the influence Quantities." The "Output Effects" are specified either as a percentage change referred to the maximum specified output voltage (E_o) or current (I_o) or as an absolute change (ΔE_o , ΔI_o) directly in millivolts or milliamperes or both. The "Influence Quantities" are the "Source Variations" (formerly a-c line variations), the "Load Variations" (formerly load regulation), the "Temperature Variations" (no change, still specified as a coefficient) and the "Time Variations" (formerly stability). The illustration below will clarify the use of the new terminology.

INFLUENCE QUANTITIES

- 1) SOURCE VARIATIONS
- 2) LOAD VARIATIONS
- 3) TEMPERATURE VARIATIONS
- 4) TIME VARIATIONS

AC INPUT SOURCE (FORMERLY "AC LINE")

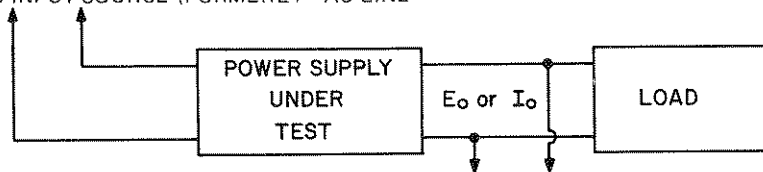

OUTPUT EFFECTS (ΔE_o , ΔI_o)

- | | |
|-----------------------------|------------------------------------------------------|
| 1) DUE TO SOURCE VARIATIONS | = SOURCE EFFECT (formerly LINE REGULATION) |
| 2) DUE TO LOAD VARIATIONS | = LOAD EFFECT (formerly LOAD REGULATION) |
| 3) DUE TO TEMPERATURE | = TEMPERATURE COEFFICIENT. (COEFFICIENT, NO CHANGE) |
| 4) DUE TO TIME | = DRIFT (formerly STABILITY) |

- b) VOLTAGE RECOVERY TIME: (for step load current), $< 50 \mu\text{sec}$.
- c) OVERSHOOT: No output voltage overshoot from turn-on, turn-off, or power failure for output settings above 25% of maximum rated output voltage. Below 25%, output voltage overshoot is a function of load current and is negligible for loads in excess of 10% of the maximum rated load current.

INFLUENCE QUANTITY	OUTPUT EFFECTS		AMPLIFIER OFFSETS ⁽⁴⁾		REFERENCE 6.2V \pm 5%
	VOLTAGE MODE ΔE_o	CURRENT MODE ΔI_o	VOLTAGE ΔE_o	CURRENT ΔI_o	
SOURCE: 105–125/210–250V a-c	$< 0.0005\%$	$< 0.005\%$	$< 10 \mu\text{V}$	$< 2 \text{ nA}$	0.0001%
LOAD: No load – full load	$< 0.005\%$ or 0.2 mV ⁽¹⁾	$< 0.01\%$	$< 200 \mu\text{V}$	$< 5 \text{ nA}$	–
TIME: 8-hours [drift]	$< 0.01\%$ or 1 mV ⁽¹⁾	$< 0.02\%$	$< 20 \mu\text{V}$	$< 2 \text{ nA}$	0.005%
TEMPERATURE: Per °C	$< 0.01\%$ ⁽²⁾	$< 0.02\%$ ⁽²⁾	$< 20 \mu\text{V}$	$< 5 \text{ nA}$	0.005%
UNPROGRAMMED OUTPUT DEVIATION: ⁽⁵⁾ (Ripple and noise)	$< 0.2 \text{ mV}$	$< 0.02\%$ of $I_o \text{ max}$	–	–	–
	$< 1.0 \text{ mV}$	$< 0.1\%$ of $I_o \text{ max}$	–	–	–

⁽¹⁾ Whichever is greater.

⁽²⁾ Models with suffix "T" have 0.005% and 0.01% per °C Temperature Coefficients in the Voltage and Current Mode respectively.

⁽³⁾ Current Mode Output Effects (ΔI_o) are measured across the external sensing resistor. This resistor must be a high quality, wirewound unit, with a wattage at least 10 times the actual power dissipated, have a Temperature Coefficient of 20 parts per million or better and drop a sample voltage of 1.0 volt at the measuring current. A resistor built as a 4-terminal network is recommended. Current control is exercised with an external 20 PPM feedback resistor.

⁽⁴⁾ Offsets and the reference contribute to output effect ΔE_o by the equation $\Delta E_o = \pm \Delta E_{ref} (R_f/R_i) \pm \Delta E_{iO} (1 + R_f/R_i) \pm \Delta I_o (R_f)$ where R_f is the feedback resistor and R_i is the input resistor from the signal reference. Use the offsets to calculate output effects when external input/feedback elements are substituted for the internal reference and voltage control in special applications.

⁽⁵⁾ Valid with one output terminal grounded or connected so that the common mode current (see par. 1-10e) does not flow through the load or (in the current mode) through a sensing resistor.

⁽⁶⁾ 20 Hz to 10 MHz.

TABLE 1-2 JQE (½-RACK) ELECTRICAL SPECIFICATIONS

1-12 SPECIFICATIONS, PERFORMANCE

a) VOLTAGE CONTROL CHANNEL.

- 1) LOCAL OUTPUT VOLTAGE CONTROL*: 10-turn precision rheostat at the front panel, resolution: 0.05% of the maximum rated output voltage ($E_o \text{ max.}$). Controls output voltage from zero to $E_o \text{ max.}$
- 2) REMOTE OUTPUT VOLTAGE CONTROL: External control can be exercised by resistance (1000 ohms per volt of output), or by a control voltage (refer to Section III for details). Control is "operational," with the JQE functioning as a unipolar power amplifier (plus output terminal common).
- 3) OFFSETS: JQE models with suffix "E" and with suffix "Y" have provisions to zero the initial (static) offset voltage. The output effects resulting from the offset *variations* are specified in TABLE 1-2. The *total* output effects (worst case) may be calculated from the relationship:

$$\Delta E_o = \pm \Delta E_r (R_f/R_i) \pm \Delta E_{iO} (1 + R_f/R_i) \pm \Delta I_o R_f$$

where: ΔE_o = total output voltage variation

ΔE_r = Change in reference or input voltage

R_f = Internal voltage control or external feedback resistor

R_i = Input or reference resistor

$\Delta E_{iO}, \Delta I_o$ = Tabulated offset variations

- 4) GAIN: The open loop gain of the voltage control channel is greater than 0.5×10^6 volts per volt.
- 5) REFERENCE: 6.2 volts nominal, positive with respect to common (+ OUTPUT), 1 milliampere maximum.
- 6) REMOTE ERROR SENSING: Rear terminals provide for connection of error sensing leads directly at the load. The four-terminal load connection compensates for the voltage drop along the load wires. Up to 0.5 volt per load wire can be compensated using remote sensing. The supply output voltage is one volt greater than normally specified for this purpose.

b) CURRENT STABILIZATION.

- 1) LOCAL OUTPUT CURRENT CONTROL*: 10-turn precision rheostat at the front panel, controls the current limit from 10% to 105% of the rated output current (I_o).

*Knob controlled on all metered models (suffix "M"). Locking type screwdriver controls on unmetered models.

- 2) **REMOTE OUTPUT CURRENT CONTROL:** Standard JOE models do not have provisions for external control of the current limit. JOE models with suffix "Y" have an additional current control channel. Separate rear terminals are provided, permitting external control (by means of an external control potentiometer or a control voltage) over the current limit function. The control voltage may be derived across the built-in reference voltage by means of a voltage divider circuit, or an independent control voltage from a separate programming source can be used (Kepeco SN Programmer, for example). JOE models with suffix "Y" have a special addendum section at the rear of the instruction manual. It contains directions for the operation of the current programming function.
 - 3) **REMOTE CURRENT CONTROL USING THE VOLTAGE CONTROL CHANNEL:** The voltage control channel of the JOE power supply may be used for the precision control of the output current. Using an external current sensing resistor and current control rheostat, the voltage channel is reconnected (by means of the rear barrier terminals), to sense the drop across the external resistor in the positive output lead. The current range achievable is approximately from 1 milliamperes to 100% I_O for standard models and from 1 microampere to 100% I_O for models with suffix "E" (see Section III for further details).
- c) **DYNAMICS.**
- 1) **VOLTAGE RECOVERY FOR STEP-LOAD CURRENT:** The time required for the stabilized output voltage to recover within the load effect band (or 2 mV, whichever is greater) is less than 50 microseconds.
 - 2) **CURRENT RECOVERY FOR STEP-LOAD VOLTAGE:** The time required for the stabilized output current to recover within the load-effect band is governed by an (exponential) RC time constant, where "R" represents the load resistance and "E" is the tabulated (TABLE 1-1) shunt capacitance.
 - 3) **PROGRAMMING SPEED:** The rate at which the JOE power supply responds to a step-program is determined by the setting of the current limit control, the value of the load resistance and the tabulated (TABLE 1-1) shunt capacity.
 - 4) **OUTPUT IMPEDANCE (See Table 1-1):** The DC and low frequency value is given by the tabulated (Table 1-2) load effects. With increasing frequency, the output impedance becomes asymptotic to the tabulated (Table 1-1) series inductance (Voltage Mode) or shunt capacitance (Current Mode).
- d) **GENERAL:**
- 1) **SERIES/PARALLEL OPERATION:** JOE models may be operated in series or parallel modes of operation and can be interconnected for "Master-Slave" tracking. NOTE: JOE MODELS WITH OPTION "VP" (BUILT-IN CROWBAR) CANNOT BE PARALLELED. SEE SECTION III FOR FURTHER INFORMATION.
 - 2) **CROWBAR SPECIFICATIONS (MODELS WITH SUFFIX "VP"):** The electronic "crowbar" circuit consists of a silicon controlled rectifier (SCR) and a sensing amplifier. The power supply output is shorted by the SCR if the output voltage exceeds a pre-adjustable limit.
Adjustable Limit Range: 3 volts to E_O max.
Triggering Time: 5–10 microseconds, with adjustable delay to minimize false triggering.
Threshold: Limit point may be set to within 5% of E_O or 0.25 volt, whichever is greater. The initial setting should account for a 2% of E_O warm-up settling effect.
Crowbar Temperature Coefficient: 0.05% of E_O per °C.

1-13 SPECIFICATIONS, MECHANICAL

- a) **DIMENSIONS AND FINISH:** Please refer to the "Mechanical Outline Drawing," FIG. 1-3.
- b) **METERS (MODELS WITH SUFFIX "M"):** Two dual-range (100% and 10% of E_O max. and I_O max), 2-inch recessed panel meters, 3% of full scale accuracy. For output voltage and current monitoring.
- c) **BAIL.** A retractable "bail" is provided for convenient bench operation of the JOE power supply.

SECTION II – INSTALLATION

2-1 UNPACKING AND INSPECTION

2-2 This instrument has been thoroughly inspected and tested prior to packing and is ready for operation. After careful unpacking, inspect for shipping damage before attempting to operate. Perform the preliminary operational check as outlined in paragraph 2-8 below. If any indication of damage is found, file an immediate claim with the responsible transport service.

2-3 TERMINATIONS

- a) FRONT PANEL: Refer to FIG. 2-3 and TABLE 2-2.
- b) REAR: Refer to FIG. 2-4 and TABLE 2-3.
- c) INTERNAL ADJUSTMENTS AND CALIBRATIONS: Refer to FIG. 2-1 and TABLE 2-1.

REFERENCE DESIGNATION	CONTROL	PURPOSE	ADJUSTMENT PROCEDURE
C403*	Delay Adjust	Adjusts Delay Time of VP	par. 3-6
R4	I_b Adjust	Control Current Calibration	par. 3-12
R14*	E_{i0} Null Adjust	Output Voltage Precision Zero	par. 3-12
R16, R36	Lag Adjust	AC Stability Adjustment	par. 5-4
R19	I_o max. Adjust	Current Limit Control Cal.	par. 5-4
R414*	V Limit Adjust (Fine)	Adjusts Output Voltage Limiting	par. 2-8
R415*	V Limit Adjust (coarse)	Adjusts Output Voltage Limits	par. 2-8

* NOTE: Optional controls, see paragraph 1-7.

TABLE 2-1 INTERNAL ADJUSTMENTS

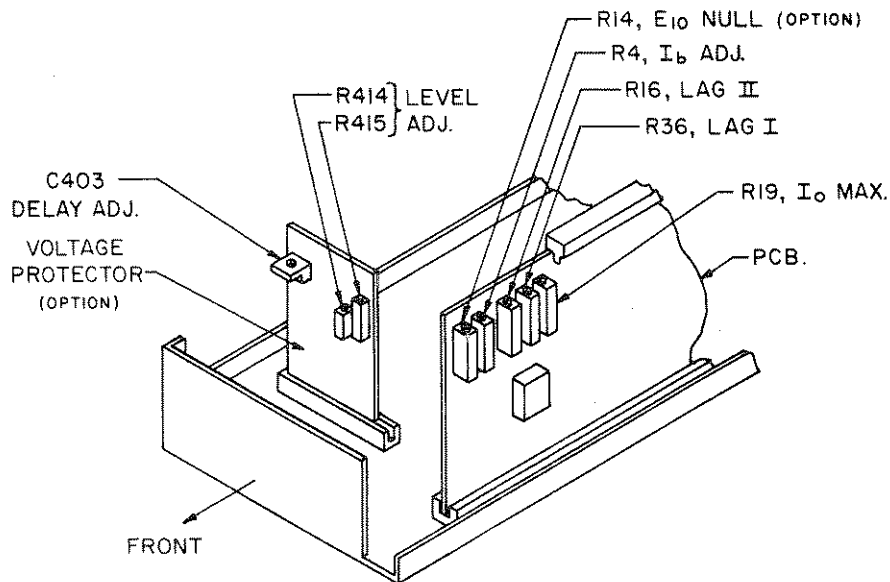

FIG. 2-1 LOCATION OF INTERNAL ADJUSTMENTS (NOT APPLICABLE TO “-HS” MODELS)

2-4 AC INPUT REQUIREMENTS

- 2-5 This power supply is normally supplied for operation on a single phase, nominal 115V AC line. For conversion to 230V AC line operation, refer to FIG. 2-2. Remove the two wire jumpers between transformer terminals indicated. Re-connect one (1) jumper between terminals indicated. Do not change any other wiring on the transformer. Change main fuse value (F201) to 1/2 its former rating.

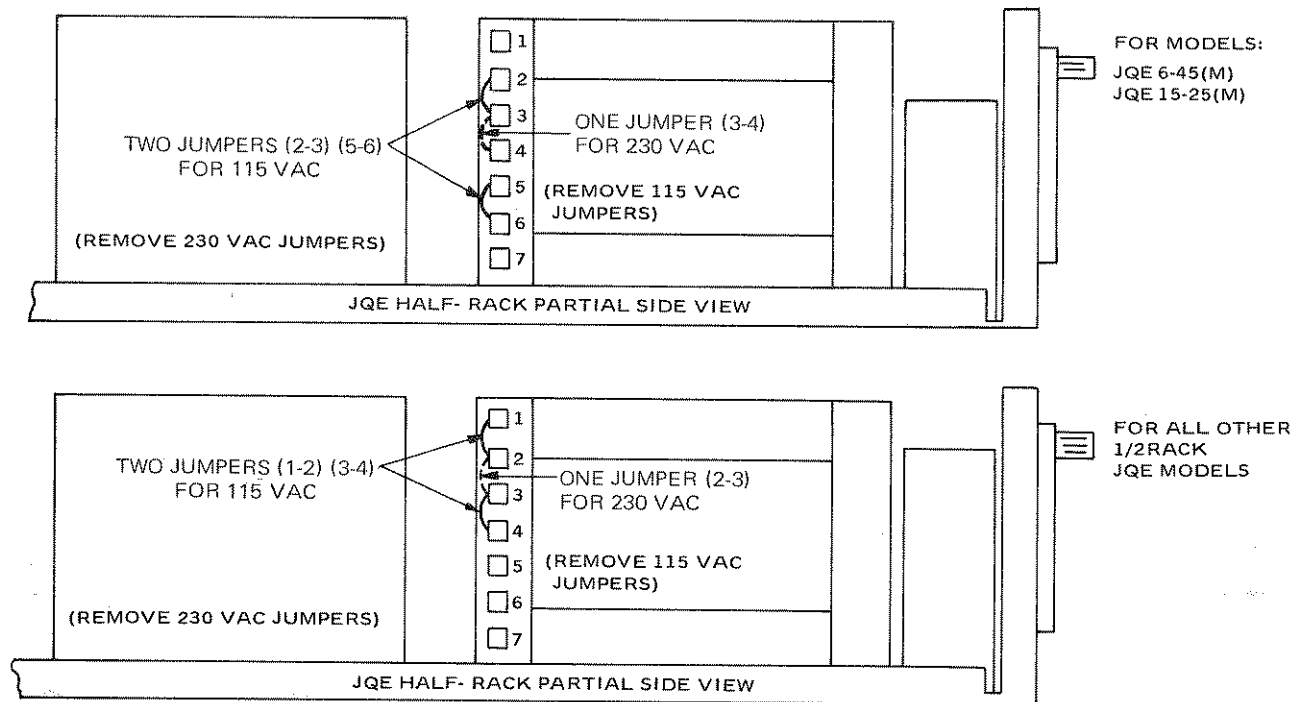

FIG. 2-2 CONVERSION TO 230V AC LINE OPERATION

2-6 COOLING

- 2-7 The power transistors and rectifiers in this power supply are maintained within their operating temperature range by means of a high efficiency heat-sink assembly, cooled by an internal fan. SIDE PANEL OPENINGS AND THE TOP OF THE CASE MUST BE KEPT CLEAR FROM OBSTRUCTIONS TO INSURE PROPER AIR CIRCULATION. Periodic cleaning of the interior of the power supply is recommended. If the power supply is rack mounted, or installed into confined spaces, care must be taken that the ambient temperature does not rise above the limit specified (Refer to Section I).

2-8 PRELIMINARY CHECK-OUT

- 2-9 A simple operating check after unpacking and before permanent installation is advisable, to ascertain whether the power supply has suffered damage resulting from shipment. Please refer to FIGS. 2-3, 2-4 for the location of the operating controls and output terminals.
- Connect power supply to 115V AC line or refer to paragraph 2-4 for 230V AC operation if required.
 - Turn CURRENT LIMIT CONTROL full clockwise. Turn VOLTAGE CONTROL fully counter clockwise. Both, VOLTMETER RANGE* and AMMETER RANGE* switch should be in the "x1" position..
 - Turn AC POWER SWITCH "on". The AC PILOT LIGHT* should be energized. Slowly turn VOLTAGE CONTROL clockwise and observe the gradual increase of the output voltage. Turn counter clockwise again until about one tenth of the maximum output voltage is reached. Set VOLTMETER RANGE switch* to the "x0.1" positions.** The VOLTMETER* should now read full scale again. Turn AC POWER SWITCH "off".

* AC pilot light, range switches and metering provided on models with suffix "M" only. Connect appropriate external metering to meterless models.

** See note following paragraph 2-9e.

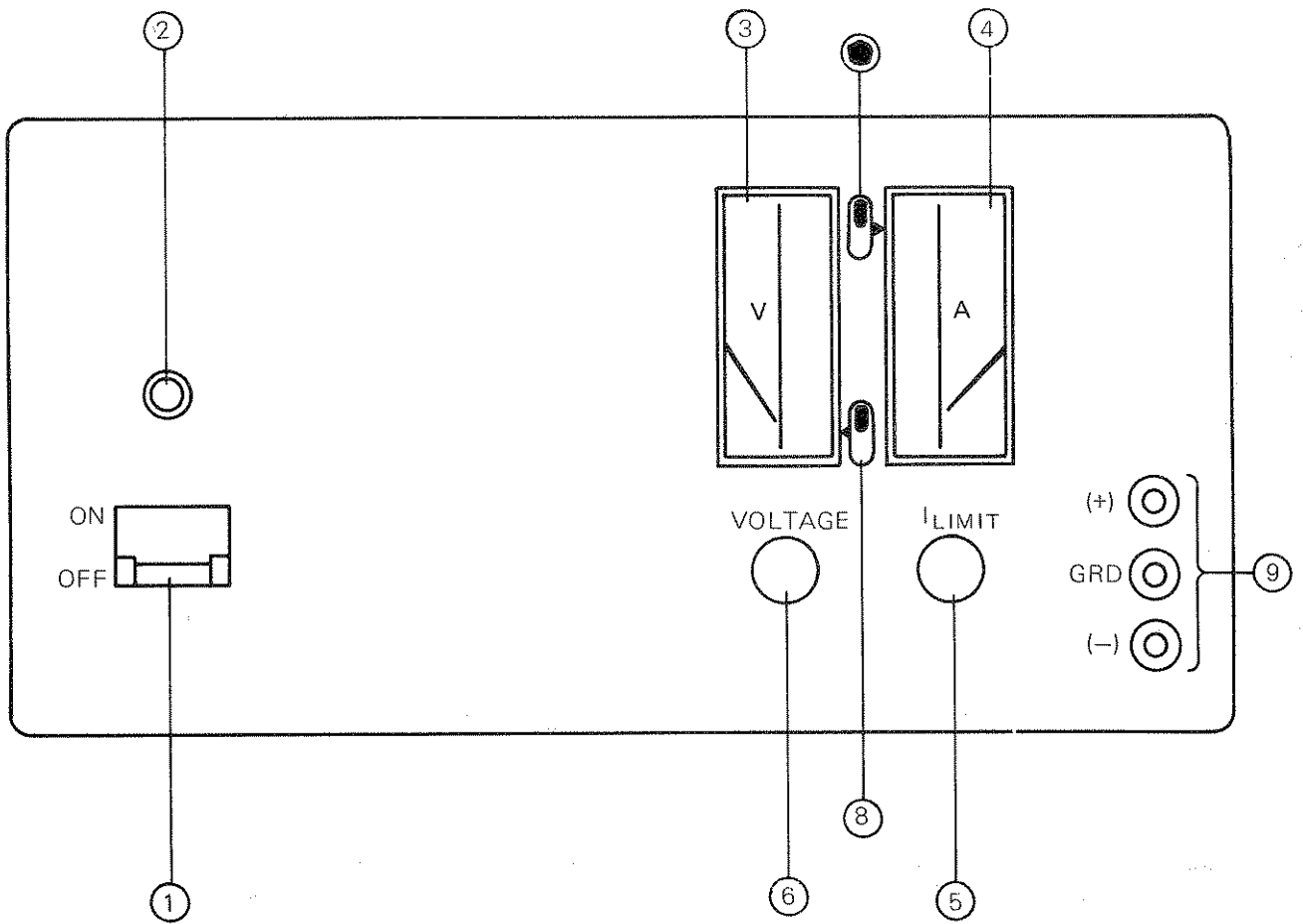
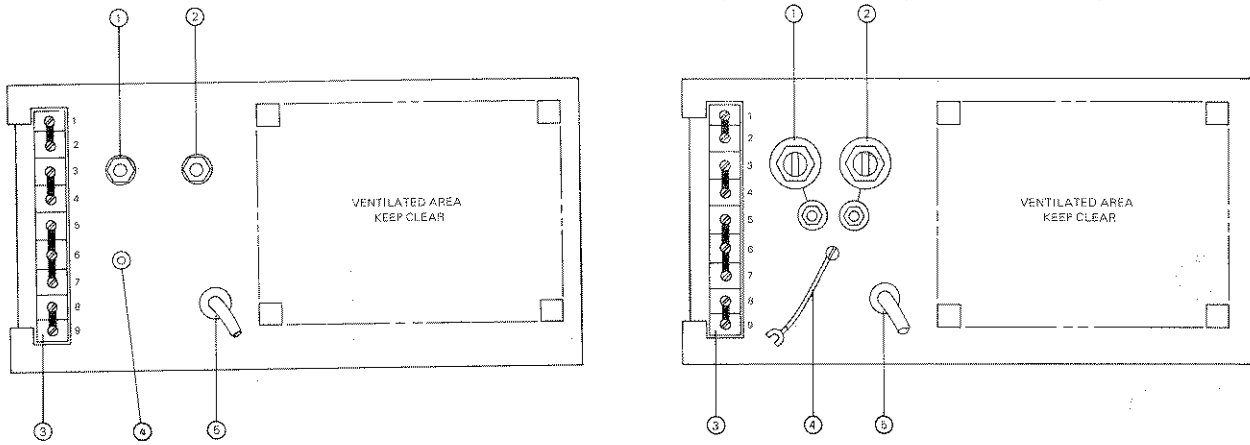

FIG. 2-3 FRONT PANEL CONTROLS AND TERMINATIONS, HALF-RACK JOE MODELS

NO.	CONTROL OR TERMINATION	FUNCTION
1	AC POWER SWITCH/ CIRCUIT BREAKER	TURNS AC POWER LINE, "ON" OR "OFF" AND PROTECTS POWER SUPPLY INPUT CIRCUITRY
2	AC PILOT LIGHT	ENERGIZES WHEN AC POWER IS "ON"
3	VOLTMETER	MONITORS OUTPUT VOLTAGE, 0- E_o max.
4	AMMETER	MONITORS OUTPUT CURRENT 0- I_o max.
5	CURRENT LIMIT CONTROL	ADJUSTS CURRENT LIMIT FROM 0-105% I_o max.
6	VOLTAGE CONTROL	ADJUSTS OUTPUT VOLTAGE FROM ZERO TO E_o max.
7	METER RANGE SWITCH, AMPERE	MAY BE SET TO FULL SCALE READING OF MAXIMUM OR 1/10 OUTPUT
8	METER RANGE SWITCH, VOLTS	MAY BE SET TO FULL SCALE READING OF MAXIMUM OR 1/10 OUTPUT
9	FRONT OUTPUT TERMINALS	FOR LOAD CONNECTION (ON MODELS WITH 15A DC OUTPUT AND LOWER ONLY)

TABLE 2-2 CONTROLS AND TERMINATIONS, HALF-RACK JOE MODELS, FRONT



a) MODELS WITH LESS THAN 25A DC OUTPUT CURRENT

b) MODELS WITH 25A DC AND 45A DC OUTPUT CURRENT

FIG. 2-4 REAR TERMINATIONS, HALF-RACK METERED MODELS

NO.	TERMINATION	FUNCTION
1	(-) OUTPUT	*NEGATIVE LOAD TERMINAL WITH GROUNDING POST
2	(+) OUTPUT	*POSITIVE LOAD TERMINAL WITH GROUNDING POST
3	REAR BARRIER STRIP	PROGRAMMING AND MONITOR TERMINALS: (1) (+) OUTPUT MONITOR (2) (+) ERROR SENSING (3) (-) OUTPUT MONITOR (4) (-) ERROR SENSING (5) INTERNAL VOLTAGE CONTROL (6) NULL JUNCTION (AMPLIFIER INPUT) (7) REFERENCE RESISTOR (8) REFERENCE VOLTAGE (9) REFERENCE RESISTOR
4	CHASSIS CONNECTION	*FLOATING GROUND LEAD TO GROUND EITHER (+) OR (-) OUTPUT VIA GROUND POST
5	AC INPUT	3 WIRE SAFETY LINE CORD

TABLE 2-3 REAR TERMINATIONS, HALF-RACK METERED MODELS

*MODELS WITH LESS THAN 25A DC OUTPUT CURRENT (FIG. 2-4a) DO NOT HAVE GROUNDING POSTS. THE CHASSIS CONNECTION ON THESE MODELS IS A TERMINAL INSTEAD OF A FLOATING GROUND LEAD.

- d) (Models suffixed "-VP" only) Check the "crowbar" action of the overvoltage protector by first adjusting the VOLTAGE CONTROL to about one quarter of the rated output voltage. Locate the "V_{limit}" adjustments (R414,415, refer to FIG. 2-1) and turn the "Coarse" adjustment (R415) slowly counter clockwise until the output voltage goes suddenly to zero as observed on the panel meter. Turn AC POWER SWITCH "off". Turn the coarse "V_{limit}" control (R415) fully clockwise again.
- e) Place a short circuit across the output.* Turn CURRENT LIMIT CONTROL counter clockwise. Turn AC POWER SWITCH "on". Slowly turn CURRENT LIMIT CONTROL clockwise and observe the gradual increase in output current. Turn counter clockwise until about one tenth of the maximum output current is reached. Set AMMETER RANGE switch to the "x0.1" position. The AMMETER should now read full scale again.



- 1) DO NOT SWITCH TO THE "X0.1" RANGES BEFORE THE OUTPUT OF THE POWER SUPPLY (VOLTAGE OR CURRENT) IS BELOW 10% OF THE MAXIMUM RATED VALUES.
- 2) CONNECT SHORT CIRCUIT (OR LOAD) TO THE HEAVY DUTY OUTPUT TERMINALS, NOT TO THE BARRIER STRIP. BARRIER STRIP TERMINALS ARE FOR VOLTAGE MONITORING AND PROGRAMMING CONNECTIONS ONLY.

2-10 INSTALLATION (Refer to FIG. 1-3 "Mechanical Outline Drawing")

- 2-11 The metered JOE Power Supply (Models with suffix "M") may be used as a bench-operated instrument. For these units, a retractable "bail" is provided to lift the power supply front to a convenient viewing and operating angle. If the metered JOE supply is to be rack-mounted, the bail, the two rear feet and the side handles must be removed.
- 2-12 The unmetered JOE Power Supply can be directly chassis-mounted into any system. Four nylon mounting stand-offs are provided at the bottom of the unit. If no additional mechanical support is provided, the unit must always be mounted so that its weight rests on the four mounting stand-offs.
- 2-13 For all installations into confined spaces, care must be taken that the temperature immediately surrounding the unit does not exceed the maximum specified ambient temperature (71°C).

2-14 GROUNDING

- a) AC GROUND (Models with suffix "M" only). The power supply is equipped with a 3 wire safety line cord and polarized plug. The third (green) wire in the line cord is connected to the chassis and the case of the unit. If a two terminal receptacle in combination with an adaptor is used, it is imperative that the chassis of the power supply be returned to AC ground with a separate lead.
- b) AC GROUND (Unmetered Models). The power supply is equipped with a three terminal barrier strip for AC input. The terminal marked "GRD" is directly connected to the power supply chassis and must be returned to AC ground.
- c) DC GROUND. The DC output is isolated from the AC power line and from any direct connection to chassis or ground.* The maximum voltage that can be supported between either output terminal and ground or chassis is 500V DC plus the maximum output voltage of the power supply. Either side of the output may be grounded. Convenient grounding terminals are provided at the front panel binding post and the rear barrier strip.

*A capacitor-resistor network (C5, R25) is connected from the negative (-) output terminal to chassis. If the output is to be grounded externally, this internal ground can be opened by removing C5 from the amplifier board (A1, see FIG. 6-2).

0

7

9

11

SECTION III – OPERATION

3-1 STANDARD POWER SUPPLY OPERATION, LOCAL CONTROL

- 3-2 GENERAL. The Power Supply is shipped from the factory with five (5) removable jumper links in place at the rear barrier strip (TB501) as shown in FIG. 3-1. THESE LINKS MUST BE IN PLACE AND SECURED TIGHTLY for standard local operation. Loose terminal links or wires at the barrier strip will cause malfunction of the power supply.
- 3-3 LOAD CONNECTION. The load may be connected in any of the two ways illustrated (FIG. 3-1,3-2). Load connecting wires should be as heavy as practicable, since load wire voltage drops will degrade regulation performance. Twisting of load wires will help to preserve the low output impedance of the power supply. To keep the DC voltage drop in the load connecting wires to a minimum, and to preserve the dynamic characteristics of the power supply (AC stability, output impedance and recovery time), load wires and error sensing leads should be as short and as large in diameter as practicable. Both lead pairs should preferably be tightly twisted. For minimum ripple and noise pick-up, the error sensing leads must be shielded. The shield, as well as one side of the output (preferably the positive), should be returned to the common ground point (Refer to FIG. 3-2).

CAUTION

THE LOAD MUST BE CONNECTED TO THE HEAVY DUTY OUTPUT TERMINALS AT THE REAR, NOT TO THE BARRIER STRIP. BARRIER STRIP TERMINALS ARE FOR MONITORING AND PROGRAMMING PURPOSES ONLY.

3-4 REMOTE ERROR SENSING

- 3-5 Specified regulation performance DIRECTLY AT THE LOAD requires the use of remote error sensing. A twisted, shielded pair of wires from the sensing terminals directly to the load will compensate for load wire voltage drops up to 0.5 volt per wire (Refer to FIG. 3-2). Observe polarities: The positive sensing wire [from terminal (2)] goes to the positive load wire.

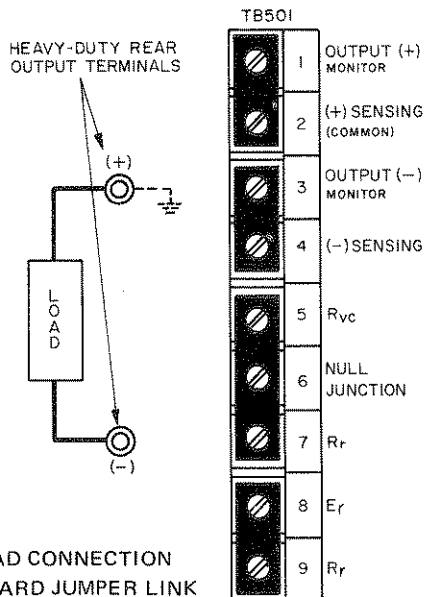

FIG.3-1 LOAD CONNECTION AND STANDARD JUMPER LINK CONNECTIONS WITHOUT ERROR SENSING

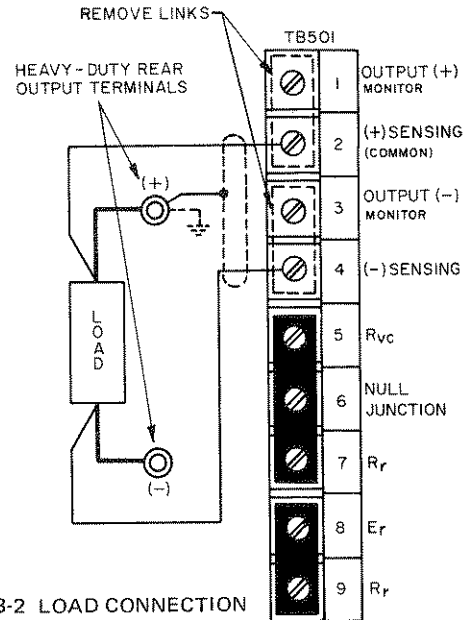

FIG. 3-2 LOAD CONNECTION USING REMOTE ERROR SENSING

3-6 OUTPUT ADJUSTMENT (Refer to FIG.'s 2-1 and 2-3 for the location of all controls)

- 3-7 a) Once the load is connected to the output terminals of the power supply as described in the previous paragraphs, the operating voltage may be adjusted to the desired value by turning the VOLTAGE CONTROL and observing the panel VOLTMETER.* The CURRENT LIMIT CONTROL may be set fully clockwise, and will in this position provide over current protection at 105% of the maximum rated output current. The CURRENT LIMIT CONTROL may also be set to intermediate values, as desired, by first turning the AC POWER SWITCH to the "off" position and then placing a short circuit across the output. Turn AC line "on". Now the required operating current is adjusted by turning the CURRENT LIMIT CONTROL to the value needed plus $\approx 2\%$. The output current will now limit sharply at this value. After the short is removed from the output, the voltage protector can be set.
- b) (For Models equipped with Voltage Protector only.) With the "V Limit" control set fully clockwise, set the output voltage as described above. Turn the coarse "V Limit" control** (R415) slowly counter clockwise, until the power supply output "crowbars", indicated by the output voltage going to zero and the circuit breaker shutting off. Turn the fine "V Limit" control (R414) slightly clockwise. The amount of "threshold" or difference voltage between operating voltage and the limiting point, is determined by this last adjustment, which should therefore be made with the "fine" control, R414. A too close adjustment towards the operating voltage may lead to spurious triggering, especially if the "delay" adjustment is set for maximum sensitivity. The minimum "threshold" voltage adjustable is 0.5 volt.) Adjust the "delay" capacitor (C413) if required. This control is factory adjusted for maximum sensitivity, consistent with reliable operation without spurious triggering. It needs re-adjustment only if extremely sensitive loads must be triggered in the shortest time possible and if some spurious triggering can be tolerated. Now the load can be connected to the power supply and operation can commence.

*Use external metering for meterless models.

**If model has only a "fine" control (R414), all VP Adjustments are made with this control.

3-8 INTRODUCTION TO REMOTE PROGRAMMING

- 3-9 GENERAL. A few general remarks may be in order to familiarize the user of this equipment with the terminology and basic equations pertaining to remote programming of Kepco Power Supplies. Electrically, the power supply, consists of the unregulated DC source (E_U), the pass element (E_P), the DC error amplifier (A) and a comparison circuit which resembles a four-arm electrical bridge. (Refer to FIG. 3-3). The elements of the bridge are arranged to produce a virtual zero at the amplifier input when the bridge circuit is at balance ($V_{AA'} = 0$). Any tendency for the output voltage to change in relation to the reference voltage (E_r) creates an error signal (e) which, by means of negative feedback and the amplifier, tends to correct the output voltage towards restoration of bridge balance.

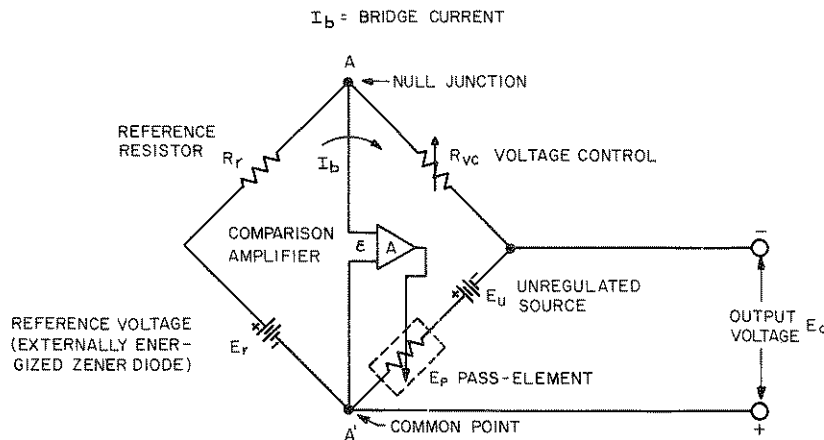

FIG. 3-3 KEPKO POWER SUPPLY CIRCUIT WITH COMPARISON BRIDGE (SIMPLIFIED)

3-10 EQUATIONS SHOWING THE OPERATION OF THE KEPKO BRIDGE

3-11 The following relationships govern the operation of the Kepco Bridge at balance, i.e., with $V_{AA}' = 0$:

$$a) \frac{E_o}{E_r} = \frac{R_{vc}}{R_r} \quad (1)$$

Where: E_o = Output Voltage
 E_r = Reference Voltage

$$\frac{E_r}{R_r} = I_b \quad (2)$$

R_r = Reference Resistance

$$E_o = I_b R_{vc} \quad (3)$$

R_{vc} = Control Resistance

I_b = Bridge or Control Current

- b) The ratio of the number of ohms control-resistance needed per volt output is termed the "CONTROL RATIO". It is normally 1000 ohm/volt in KEPKO Power Supplies.
- c) As can be seen from equation (1), the output voltage E_o can be controlled by varying any one of the three quantities. Rewriting equation (1) we have:

$$E_o = \frac{E_r}{R_r} \times R_{vc}$$

The ratio $\frac{E_r}{R_r}$ constitutes the bridge or control current I_b . (Eq. 2).

- d) Therefore, we can write: $E_o = I_b R_{vc}$ (Eq. 3).

Making I_b a precision quantity (precision bridge current adjustment is described in par. 3-16), establishes a precise programming ratio, so that the accuracy of E_o is solely dependent upon R_{vc} . This mode of operation is referred to as "RESISTANCE PROGRAMMING" and is covered in detail in Par. 3-19.

- e) Rewriting equation (1), $E_o = E_r \frac{R_{vc}}{R_r}$, we can make E_r the variable which controls E_o .

This type of control is referred to as "VOLTAGE PROGRAMMING" and is covered in Par. 3-25.

- f) Many other modes of control are of course possible, some of them are described in the following paragraphs. For a more extensive treatment and a detailed theoretical view of power supply applications see the current KEPKO Application Literature, available from your Kepco Representative or directly from Kepco Applications Engineering Department.

NOTE: For all programming and adjustment components, use high quality, wire-wound, resistors with a T.C. of 20 p.p.m. or better.

3-12 ADJUSTMENTS FOR EXACT PROGRAMMING RATIO*

3-13 Referring to equation (3): $E_o = I_b R_{vc}$, it is seen that if $I_b = 1$ mA, 1000 ohms of control resistance (R_{vc}) is needed for each volt of output. Making I_b therefore a precision quantity the accuracy and linearity of the output voltage will then solely depend upon R_{vc} .

3-14 Again referring to equation (3), we see that if $R_{vc} = 0$ (shorted out), the output voltage should be zero. A small negative offset voltage (in the millivolt range) exists however under this condition at the output.

3-15 Both inaccuracies, the slightly larger bridge current (I_b) and the small negative offset voltage (E_{io}) may be adjusted to provide a linear and precise programming ratio. Refer to FIG. 2-1 for the location of the calibration controls.

3-16 PROCEDURE. PRECISION PROGRAMMING RATIO ADJUSTMENT (Refer to FIG. 3-4)

- a) Equipment Required:

- 1) Precision digital or differential voltmeter (M1).
- 2) Precision resistor, accuracy comparable to M1. The value is not important, but must be known, for every 1000 ohms, 1 volt will appear across M1. (R_{vc}).
- 3) Single pole, single throw switch (S1).

* Applicable for models with suffix "E" only.

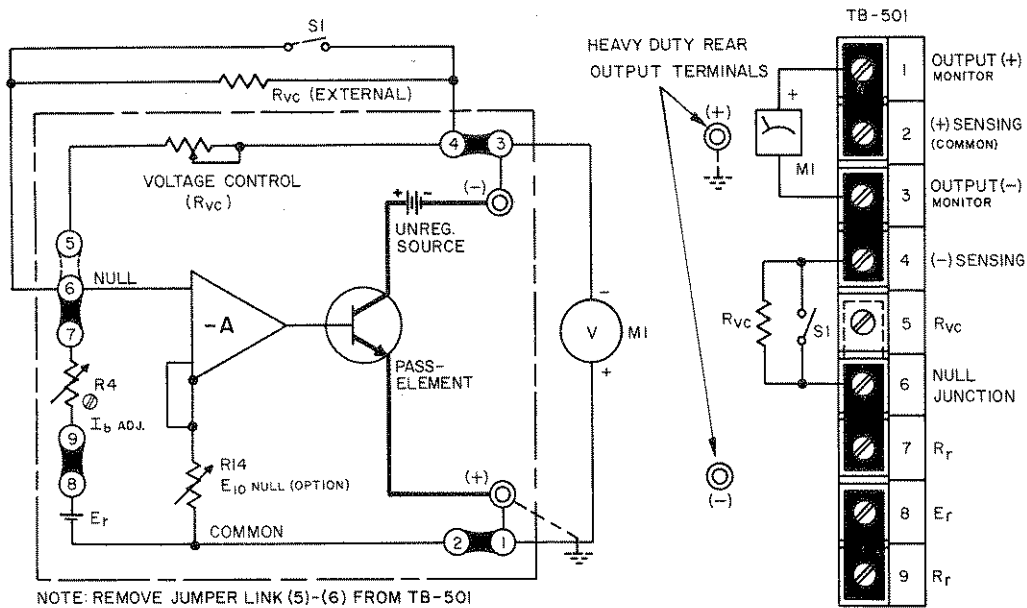

FIG. 3-4 CONNECTIONS FOR PRECISION PROGRAMMING RATIO ADJUSTMENT

- b) Connect calibration set-up as shown in FIG. 3-4 and connect the power supply to the AC power line.
- c) With S1 "open", and $R_{VC} = 5\text{ K ohms}$, approximately 5 volts will be read-out on M1. Adjust R4 (I_b adjustment) until exactly 5 volts are read-out on M1.
- d) Close S1 and note deviation from zero on M1 (approx. 2 to 8 mV negative). Adjust R14 (zero adjustment) until exactly zero volts read-out on M1.
- e) Open S1 and check the 5 volt reading. Repeat "c" and "d" as necessary to achieve the desired accuracy. FIG. 3-5 below shows graphically how the programming ratio can be precision adjusted.

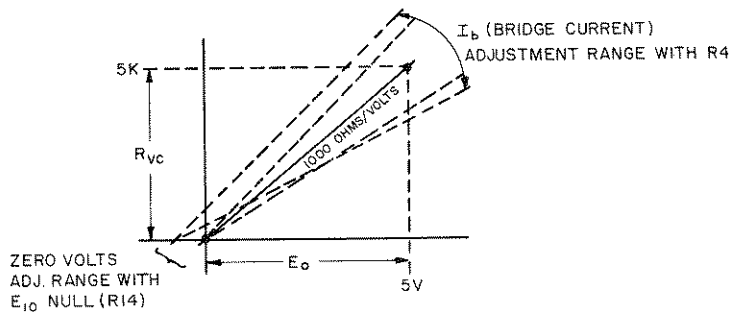

FIG. 3-5 ESTABLISHING PROGRAMMING LINEARITY

3-17 GENERAL RULES FOR REMOTE PROGRAMMING

- 3-18 All remote programming applications require the observance of a few basic rules to insure proper functioning of the power supply in the particular mode of operation selected. These rules should be remembered before each application and especially if malfunctioning of the programming set-up is experienced.
- 1) GROUNDING. Ground loops due to multiple and indiscriminant grounding of various equipment are the cause of the majority of complaints about "high ripple or noise". They can be easily avoided by grounding the power supply at one point only to which all shielded cables and equipment cases are connected. If possible, one side (preferable the positive one) of the power supply output should also be grounded. Frequently, high ripple is introduced by programming sources or instruments used at the input (null junction) although all grounding rules have been observed. This may be due to the external instruments or source's close coupling to the AC line. In these cases only isolation (i.e. battery operated devices) is the answer. It must also be remembered that input and output of the power supply are "common", so that if the output is not grounded, the input source must be isolated for the maximum output voltage to be programmed, plus the amount of voltage the common is "off ground".
 - 2) CONNECTIONS. All external connections, especially the rear barrier strip terminal screws, must be tight. Series malfunctions may be caused by open feedback loops or programming connections.
 - 3) INPUT SOURCES. If specified performance is expected when remote programming, external input or reference sources must have specifications equal to or better than that of the power supply.
 - 4) PROGRAMMING RESISTORS Programming resistors should be high quality wirewound units with temperature coefficients of 20 parts per million or better. Their wattage rating must be at least 10 times the actual power dissipated. Although the control current through these resistors is only 1 mA, an error current exists when programming large voltage excursions. The magnitude of this error current equals the change in output voltage, divided by the final resistance of the programming resistor. (If, for example, the voltage step is from 50 volts to zero, ($\Delta E_O = 50 \text{ V}$) and the final resistance of the programming resistor is $\Delta R_{VC} = 2 \text{ ohms}$, $I_{\text{peak}} = 25 \text{ A}$. The duration of the peak error current depends upon the size of the output capacitor. I_{peak} decays exponentially as the output voltage assumes the final value.
 - 5) EXTERNAL SWITCHING. If step-switch devices are used in resistance programming, they must be of the "make before break" variety to avoid programming infinity. Programming resistors must have a voltage rating at least equal to the maximum output voltage of the power supply.

3-19 OUTPUT VOLTAGE PROGRAMMING WITH EXTERNAL RESISTANCE

The output voltage of the Power Supply may be controlled remotely by an external resistance, replacing the built-in voltage control resistance which is disconnected at the rear barrier strip. The value of the programming resistance may be calculated by referring to the transfer function derived earlier (Eq.1):

$$E_O = R_{VC} \times \frac{E_r}{R_r}$$

Since $\frac{E_r}{R_r} = I_b$ (2), it follows that $E_O = I_b R_{VC}$ (3)

Referring to Equation (3), we see that since I_b is 1 mA in KEPCO Power Supplies (and can be precisely adjusted as shown in Par. 3-12), for every volt of output, 1000 ohms control resistance must be provided. This corresponds to a "Programming Ratio" of 1000 ohms per volt.

3-20 PROCEDURE (Refer to FIG. 3-6)

- a) Determine value of programmin resistor(s) for output voltage desired.
- b) Using two-wire, shielded cable, connect the chosen resistors to terminals (4) and (6). Connect the shield to the "ground" terminal.
- c) The output voltage will vary from zero to $(1 \text{ mA}) \times (R_{VC})$, as R_{VC} is adjusted from zero to its maximum value.

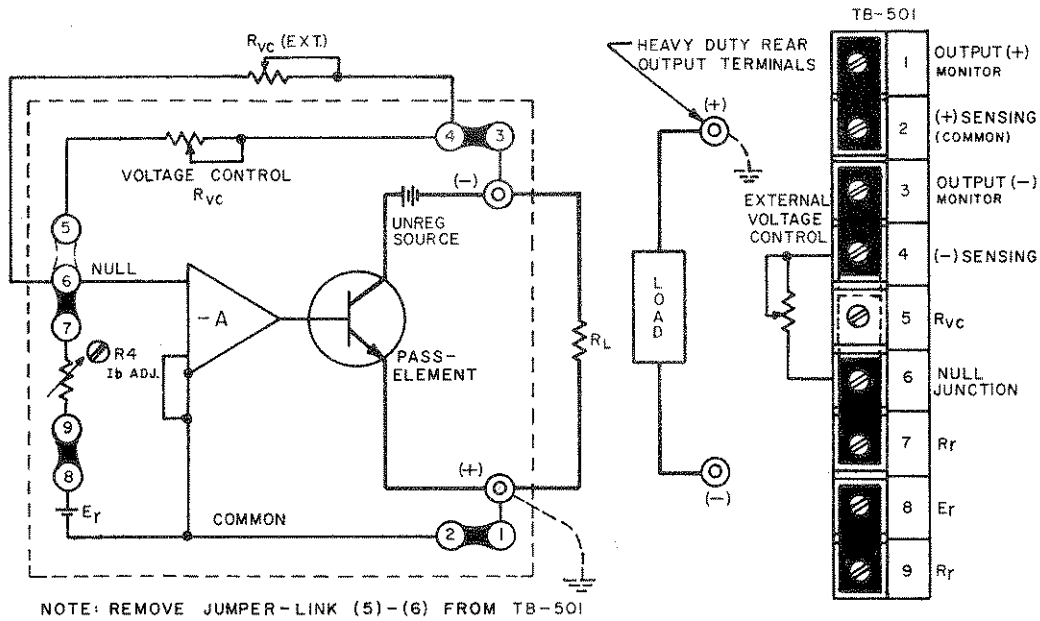

FIG. 3-6 REMOTE RESISTANCE PROGRAMMING

3-21 PROGRAMMING BY CONDUCTANCE:

3-22 For special applications, the output voltage E_o can be adjusted by varying the bridge current. The relationship governing this type of programming is:

$$E_o = E_r (R_{vc}) (G), \text{ (Eq. 4)} \quad \text{Where: } G = \frac{1}{R_r + R_x} = \text{programming conductance}$$

$$E_o = \frac{E_r}{R_r + R_x} \times (R_{vc})$$

- E_o = output voltage
- E_r = reference voltage
- R_{vc} = control resistance
- R_r = reference resistance
- R_x = programming resistor

Since $\frac{E_r}{R_r} = I_b$ and $E_o = I_b R_{vc}$, the output voltage varies directly as I_b changes. Changing I_b with the help of an additional resistor in series with R_r results in an inversely proportional change of I_b , since now:

$$I_b = \frac{E_r}{R_r + R_x}$$

This method of output voltage adjustment is therefore referred to as conductance programming.

3-23 Conductance programming is a reciprocal function when analyzed in terms of resistance, but perfectly proportional

$$E_o \propto \frac{1}{R_x}$$

It can be very useful, especially over a limited range and for small changes in output voltage. Another distinctive advantage of this type of programming is the "built-in" safety feature. Should the programming circuit open accidentally, the programming resistance becomes infinite, the conductance is zero, and consequently, the output voltage becomes zero.

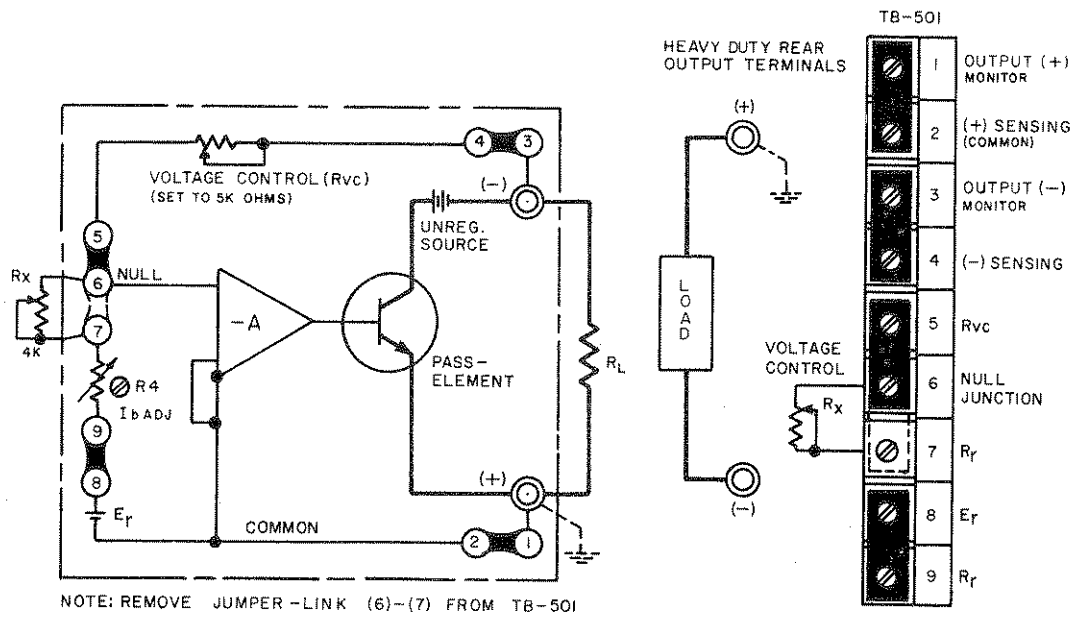

FIG. 3-7 REMOTE CONDUCTANCE PROGRAMMING

3-24 PROCEDURE (Refer to FIG. 3-7)

EXAMPLE: E_o desired = 3 to 5 volts.

- a) Select R_{vc} for maximum desired output voltage E_o .

$$R_{vc} = \frac{E_o}{I_b} ; R_{vc} = \frac{5V}{1mA} = 5K \text{ ohms.}$$

Set built in R_{vc} to 5K ohms, or disconnect and use external resistor.

- b) A change of E_o to 3 volts requires a bridge current change of:

$$\Delta I_b = \frac{\Delta E_o}{R_{vc}} = \frac{2 \text{ volts}}{5K \text{ ohms}} = 0.4mA$$

- c) Since $I_b = \frac{E_r}{R_r} = 1mA$, the additional resistance needed is:

$$I_b (R_r + R_x) = E_r ; R_x = \frac{E_r}{I_b} - R_r \text{ or } R_x = \frac{6 \text{ volts}}{0.6 \text{ mA}} - 6K = 4K \text{ ohms.}$$

A 4K ohm, WW, low T.C. potentiometer, connected as shown in FIG. 3-7, will change the output voltage from 3 to 5 volts when varied from zero to 4K ohms.

NOTE: A word of caution may be in order in regard to the changing of the bridge current. The 1mA value has been selected for maximum stability in the zener reference circuit. A large departure from this value is not advisable. If a $\pm 50\%$ change in I_b is not sufficient to achieve the desired voltage swing, an external reference supply can be used.

3-25 REMOTE PROGRAMMING WITH EXTERNAL CONTROL VOLTAGE

3-26 The output voltage of KEPCO power supplies may be controlled by an external, variable voltage source, which supplies the necessary control current, formerly delivered by the (now disconnected) internal, fixed reference source. This mode of operation is termed "Voltage Programming". It can be mathematically expressed by referring to basic equation (1):

$$\frac{E_o}{E_r} = \frac{R_{vc}}{R_r} \quad (\text{Eq. 1})$$

Solving for E_o , and designating the external programming components " E_i, R_i "

the result is:

$$E_o = -E_i \times \frac{R_{vc}}{R_i} \quad (\text{Eq. 5})$$

3-27 As seen from the expression (Eq.5), if the ratio R_{vc}/R_i (which represents the closed loop gain of the system) is held constant, E_o will vary linearly with E_i , the external programming voltage. The above expression (Eq.5) is seen to be similar to the operational amplifier transfer function in the inverting configuration. The voltage programmed power supply does in fact become a unipolar power amplifier with potentially very high power gain but with limited frequency response. (Refer to FIG. 3-8). The limited frequency response is largely due to the effect of the output capacitor (C_o) acting as a low-pass filter and preventing the output voltage (E_o) from varying rapidly. The output voltage may be varied over the full range, bounded on the high end by the maximum rated value. A practical example to illustrate component selection will be given below.

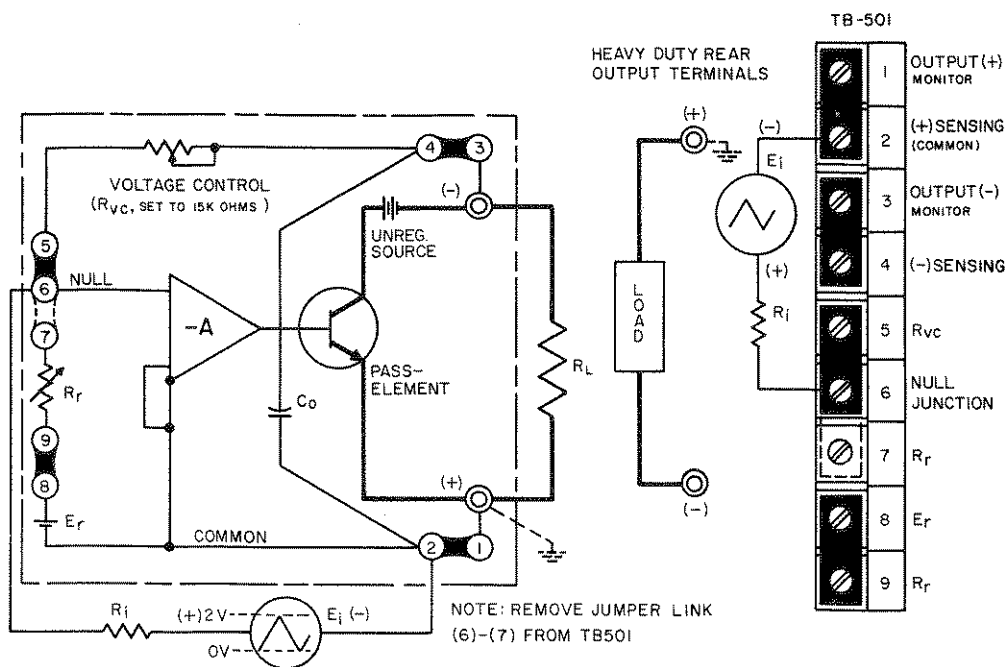

FIG. 3-8 THE POWER SUPPLY IN THE OPERATIONAL AMPLIFIER MODE

3-28 Example: A power supply with a rated maximum output voltage of 15 volts is to be voltage programmed over its full range (0 to 15V) by a triangular, positive increasing source with a peak output voltage (E_i) of 2 volts, and able to deliver at least 1 mA control current. Since the required voltage gain is: $E_o/E_i = 15/2 = 7.5$, the ratio R_{vc}/R_i must also equal 7.5. If the internal voltage control is retained, in this case, since $R_{vc} = 15 \text{ K ohms}$, R_i must equal $15 \text{ K}/7.5 = 2 \text{ K ohms}$. FIG. 3-8 shows the Power Supply as an operational amplifier and the necessary rear barrier connections for this mode of operation.

3-29 CONSTANT CURRENT OPERATION

3-30 A KEPCO power supply can be set up to deliver constant current by the addition of an external sensing resistor and a current control. In the constant current operating mode, the voltage comparison bridge is interconnected with an external current sensing resistor, R_s , and a current control, R_{cc} (as shown in FIG. 3-9) to maintain a constant voltage drop across R_s . In this way, an adjustable constant load current is obtained. Characteristic of the constant current supply is ability to change its output voltage automatically in order to maintain a constant current through a range of possible load resistances. The range of output voltage that the supply can deliver and simultaneously maintain constant current, is referred to as the "COMPLIANCE VOLTAGE".

3-31 The current sensing resistor R_s is chosen to develop a 0.5 volt drop at the maximum desired current.* It is calculated by dividing this current into 0.5 volt. The value of R_s is not critical and can be the nearest standard resistance available. Several facts should be kept in mind however, when choosing R_s . A compromise must be made between a large and a small value. While a large value is desirable for good current regulation, it is less so in view of the power dissipated across it. It must be remembered that all the load current is flowing through R_s and the input to the regulator is connected across it. It is therefore vital that all extraneous changes across R_s , i.e. resistance change due to temperature, are kept to a minimum. A high quality, low T.C. (20 PPM) resistor, at least ten times the actual wattage needed, is therefore strongly recommended. In practice, R_s is usually selected for a 0.5 volt sample at maximum output current desired. *If more than a 10:1 ratio of output current is needed, several values of R_s should be selected and switched in or out as required.

* For KEPCO Power Supply with maximum rated output currents of 5A DC or less, a 1 volt sample at the maximum desired current should be used.

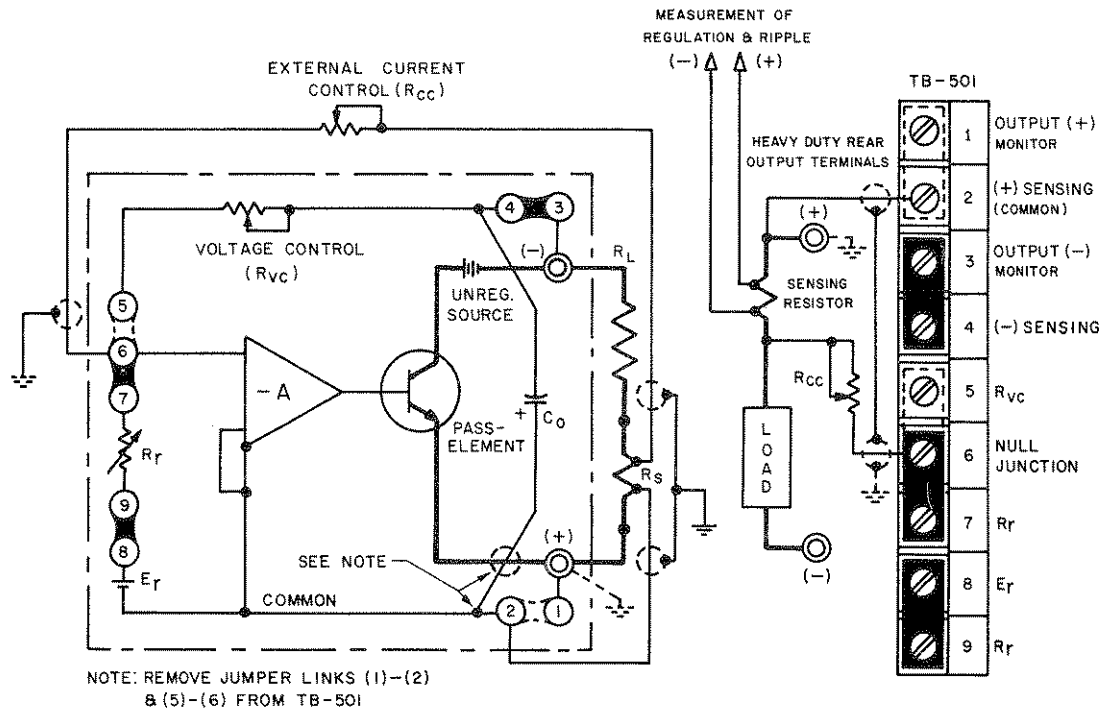

FIG. 3-9 CONSTANT CURRENT OPERATING MODE

NOTE: R_s should be physically located as close to the (+) output terminal of the power supply as possible. If, however, long output and sensing leads cannot be avoided, the (+) terminal of the output capacitor (C_o) must be internally reconnected from the (+) sensing to the (+) output terminal.

3-32 The current control resistor, R_{cc} is chosen on the basis of the control ratio of the Kepco comparison bridge, and V_s the maximum voltage across R_s . If R_s was selected for 0.5 volt drop, then $V_s = 0.5$ volt and $R_{cc} = V_s$ times (control ratio), or

$$R_{cc} = 0.5 \text{ volt} \times \frac{1000 \text{ ohm}}{\text{volt}} = 500 \text{ ohms. A high quality, low T.C. (20 PPM) resistor is recommended}$$

for R_{cc} .

3-33 PROCEDURE (Refer to FIG. 3-9)

The actual component calculation for current regulation is perhaps best shown by a practical example. A KEPCO Power Supply with a rated maximum output current of 50 A DC is to be set up for current regulated output from 5A to 50A (1:10 ratio).

a) R_s is chosen by: $R_s = \frac{0.5 \text{ volt}}{50 \text{ A}} = 0.01 \text{ ohm.}$

$$P_{\text{diss}} = V_s \times I_{\text{max.}} = 0.5 \text{ volt} \times (50 \text{ A}) = 25 \text{ watts. (use 250 watt)}$$

NOTE: A heavy duty, 4 terminal meter shunt or a power resistor in the TEPRO "TMK" series is required. Inquire at KEPCO if special values are needed.

b) The control resistance R_{cc} is found by calculating its limits:

$$R_{cc} \text{ (max.)} = V_s \text{ (max.)} \times \text{control ratio} = 0.5 \text{ V} \times \frac{1000 \text{ ohms}}{\text{V}} = 500 \text{ ohms.}$$

$$R_{cc} \text{ (min.)} = V_s \text{ (min.)} \times \text{control ratio} = 0.05 \text{ V} \times \frac{1000 \text{ ohms}}{\text{V}} = 50 \text{ ohms.}$$

As R_{cc} is therefore varied from 50 ohms to 500 ohms, the regulated current will vary from 5 to 50 mA. The compliance voltage will change in the same ratio (10:1), its absolute value depending on the load resistance used.

c) A large output current range (1 mA to 50 A) could be covered if three separate sensing resistors were to be calculated on the basis of a 0.5 volt sample at maximum current:

a) R_s^1 (For 5 to 50 A) = $0.5\text{V}/50 \text{ A} = 0.01 \ \Omega$ (250 watt)

b) R_s^2 (For 0.5 to 5A) = $0.5\text{V}/5\text{A} = 0.1 \ \Omega$ (25 watt)

c) R_s^3 (For 0.05 mA to 0.5 A) = $0.5\text{V}/0.5 \text{ A} = 1 \ \Omega$ (2.5 watt)

3-34 SERIES OPERATION OF KEPCO POWER SUPPLIES

3-35 GENERAL. Kepco Power Supplies can be series-connected for increased voltage output, provided the specified limits on voltage to chassis are not exceeded. When series-connected, the supplies should be protected by means of a semiconductor diode across the output terminals of each power supply, as shown in FIG. 3-10. The peak inverse rating of these diodes must be at least as large as the output voltage of the supply to which they are connected. The continuous current rating of the diodes should be at least as great as the largest short-circuit current of the interconnected supplies.

3-36 Two basic series connection methods are generally used, the "Automatic Series Connection", as illustrated in FIG. 3-10, and the "Master-Slave" connection, shown in FIG. 3-11. The basic difference between these two alternate methods lies in the manner of the output control. While in the "Automatic" connection the outputs of both supplies may be controlled individually, in the "Master-Slave" connection, control is exercised from the "Master" supply alone, while the "Slave" supply follows the master command in a ratio which may be pre-determined by the user. The latter method of series operation is therefore frequently termed "Automatic Tracking".

3-37 PROCEDURE FOR AUTOMATIC SERIES CONNECTION

- a) Connect load as shown in FIG. 3-10. Keep voltage drop in load wires as low as practical by using heavy gauge wire.
- b) Connect protective diodes across respective output terminals.
- c) Remove jumpers as shown and connect error sensing leads. These leads should also be as heavy as practicable, and should be twisted and shielded.
- d) Turn supplies on and adjust voltage on either control as required.

3-38 The "Master-Slave" series connection method is illustrated in FIG. 3-11. As seen from the figure, the reference voltage (E_r) of the "Slave" supply is disconnected and its input or null junction is connected to the output of the "Master" supply via the tracking resistor (R_t). The "Slave" supply output is thus completely dependent on the "Master" output voltage:

$$E_{Os} = E_{Om} \frac{R_{Vcs}}{R_t}, \text{ where: } \begin{array}{l} E_{Om} = \text{Output Voltage, Master} \\ E_{Os} = \text{Output Voltage, Slave} \\ R_t = \text{Tracking Resistor} \\ R_{Vcs} = \text{Voltage Control Resistance, Slave} \end{array}$$

As evident from the equation above, if the tracking resistor (R_t) value is equal to that of the voltage control resistor of the "Slave" supply (R_{Vcs}), a "tracking ratio of 1:1 is achieved and the output of the "Slave" will equal that of the "Master". If a single load is connected to the series "Master-Slave" combination, twice the "Master" output voltage is applied to it. If separate loads are connected, identical voltages are applied to the individual loads.

3-39 The ratio E_{Os}/E_{Om} can be readily changed if the application so requires by simply altering the value of either R_{Vcs} or R_t . In practice, since R_{Vcs} is the ten-turn voltage control rheostat of the "Slave" supply, the tracking resistor (R_t) is selected for the desired tracking ratio. The value of R_{Vcs} is determined from the parts list and R_t is selected accordingly to the selected ratio. For a 1:1 ratio $R_t = R_{Vcs}$, for a 1:2 ratio, $R_t = 1/2 R_{Vcs}$ etc.

3-40 PROCEDURE FOR MASTER-SLAVE SERIES CONNECTION

- a) Connect load as shown in FIG. 3-11. Keep voltage drop in the load wires as low as possible by using heavy gauge wire.
- b) Connect protective diodes across the respective output terminals.
- c) Remove jumper links as shown (FIG. 3-11) and connect error sensing leads if remote sensing is desired. Sensing leads should be twisted and shielded.
- d) Select value of the tracking resistor (R_t) and connect with shielded wire as shown (FIG. 3-11).
- e) Turn supplies "on", and adjust output voltage on the "Master" Voltage Control as desired.

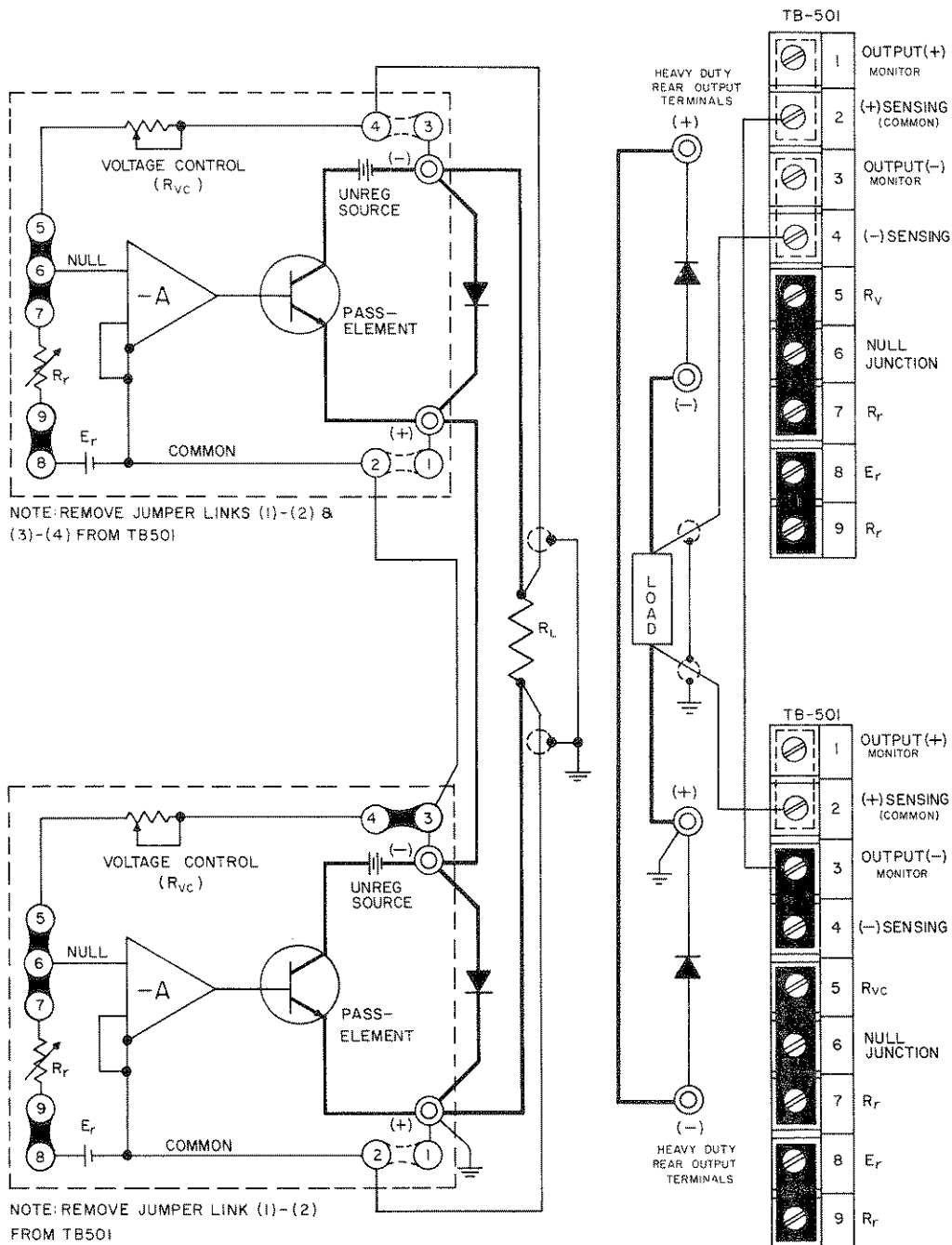

FIG. 3-10 AUTOMATIC SERIES CONNECTION OF KEPKO POWER SUPPLIES

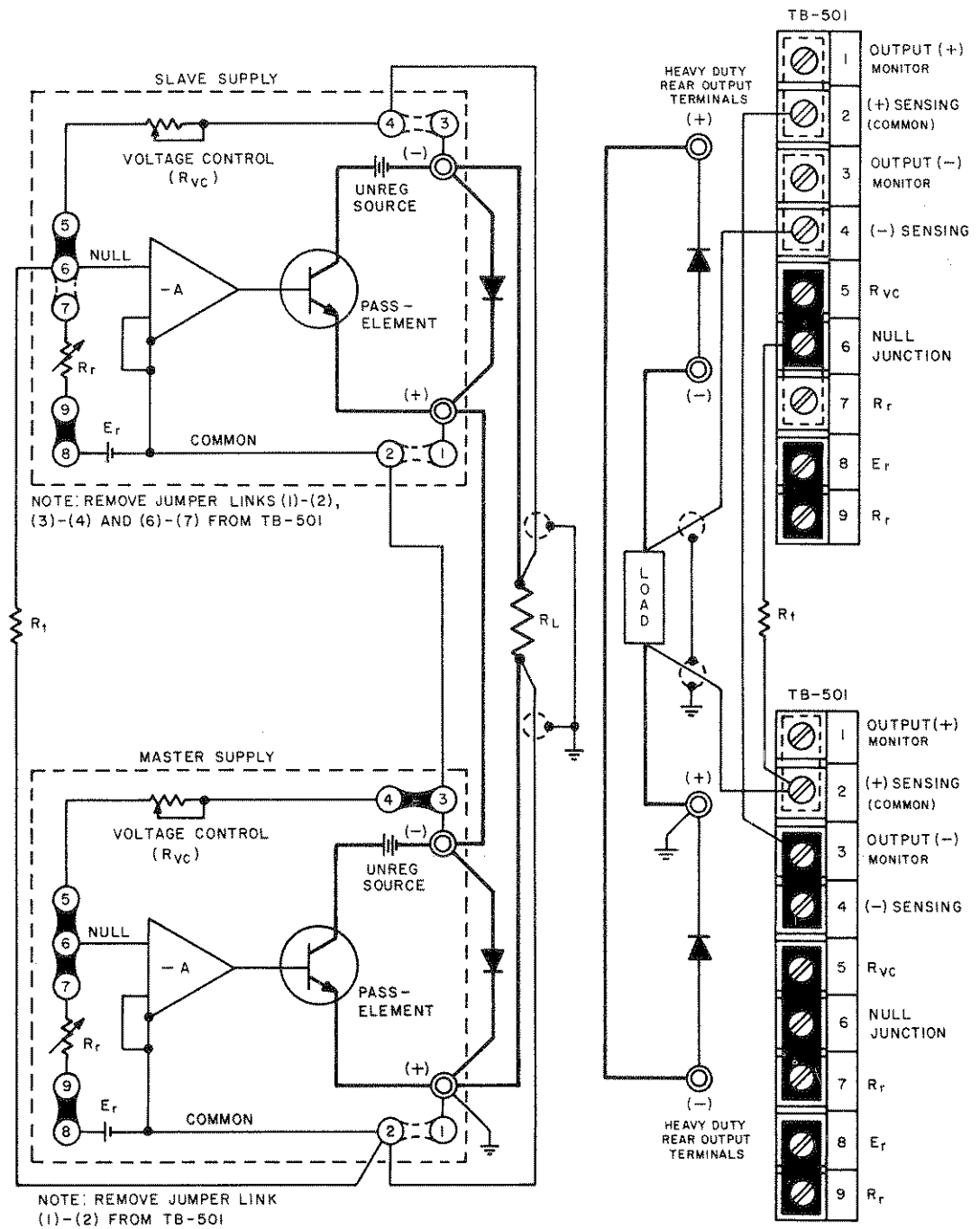

FIG. 3-11 MASTER-SLAVE SERIES CONNECTION OF KEPCO POWER SUPPLIES

PARALLEL OPERATION

GENERAL. Kepco power supplies equipped with an overvoltage crowbar (all CPS models and JQE models with suffix "VP") cannot be operated in parallel for increased output current. A triggered crowbar in a power supply working in a parallel configuration would have to absorb the total output current of the other power supplies.

EMERGENCY SITUATIONS. Sometimes a situation arises where additional output current is required and only power supplies with lower than required current ratings are available. In these cases, the power supplies can be paralleled if the crowbar circuit in each unit is disabled. Refer to the component location drawing for assembly A4 (Section VI of this manual) and remove R402 from the overvoltage protector assembly (A4). If overvoltage protection is considered essential in the application at hand, a separate crowbar circuit, rated for the *total* output current in the parallel connected power supplies must be used. (Refer to Kepco VIP models.) Two basic methods of paralleling power supplies are described in pars. 3-41 to 3-46. **USE PARALLELING IN EMERGENCIES ONLY. CROWBAR CIRCUITS MUST BE DISABLED.**

3-41 PARALLEL OPERATION (AFTER DISABLING THE CROWBAR CIRCUIT ONLY)

3-42 **GENERAL.** As in the previously described "series" connections, an "Automatic" or a "Master/Slave" connection method can be chosen. The choice between the two methods will depend on the application at hand. For constant loads or small load variations (load changes *smaller* than the maximum output range of a *single* power supply), the "Automatic" parallel connection can be used. For load changes *exceeding* the maximum rating of a *single* power supply, the "Master/Slave" method is suitable. For either method, some general rules should be observed:

- 1) Parallel *only* supplies which can be adjusted to the same compliance (output) voltage.
- 2) Error sensing, as shown in the following diagrams, can be used to compensate for load wire voltage drops.
- 3) Load wires should be *as short as practicable*. Select wire gauge *as heavy as possible* and twist wires tightly. Approximately *equal* lengths of wire should be used.
- 4) *Common* a-c power source "turn-off" for all supplies is recommended.

3-43 AUTOMATIC PARALLEL CONNECTION

3-44 **PROCEDURE FOR AUTOMATIC PARALLEL CONNECTION** (See FIG. 3-13)

- 1) Connect the power supplies to be paralleled to a common a-c source (preferably with a common "on-off" power switch).
- 2) *Without* connecting the power supplies to the load or to each other, turn a-c power "on," and adjust the output voltage on each supply to the required compliance voltage.
- 3) Adjust *both* "current" controls to their maximum (extreme clockwise) position. Turn a-c power "off."
- 4) Make all load interconnections as shown in the connection diagram (refer to FIG. 3-13) *except the error sensing connections* (these connections may be added later if needed).
- 5) With the *individual* a-c power switches of the two power supplies in the "on" position, turn *common* a-c power switch "on." Observe output current meters on *both* units. Since the initial output voltage adjustments were not identical, *one* of the power supplies (to be designated SUPPLY #1) will be at a slightly higher output voltage than the other (to be designated SUPPLY #2). Consequently, SUPPLY #1 will deliver its maximum load current and will operate in the current limit mode. The rest of the load current is delivered by SUPPLY #2, which is operating in the voltage mode.

- 6) The "current" control of SUPPLY # 1 can now be adjusted, as to equalize the total load current between SUPPLY # 1 and SUPPLY # 2, and operation can proceed. ERROR SENSING CAN BE USED FROM SUPPLY # 2 ONLY.

NOTE: The diagram below (refer to FIG. 3-12) shows how the two power supplies operate in the parallel mode. As seen from FIG. 3-12, load variations should be confined within the stabilization region of SUPPLY # 2 since there is an initial adjustment error (ΔE_o) between the two supplies.

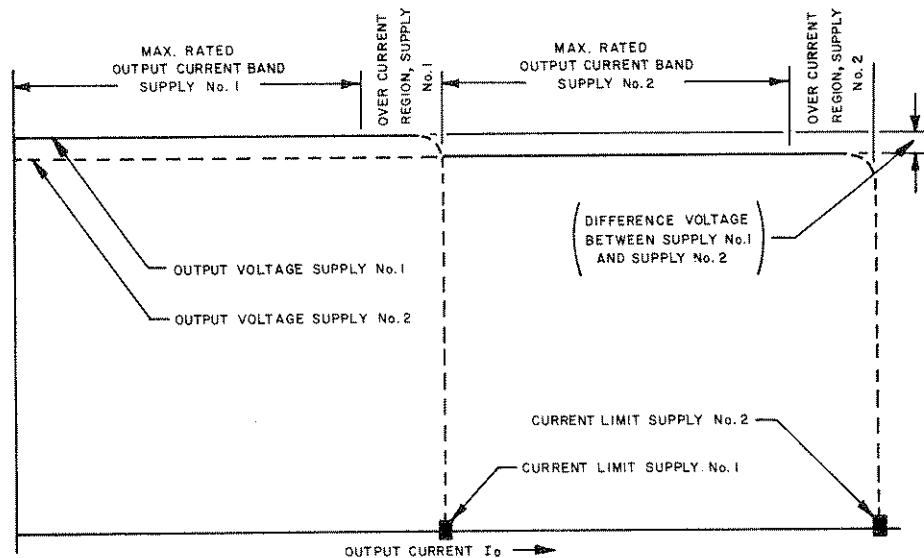

FIG. 3-12 "AUTOMATIC" PARALLEL OPERATION (TWO SUPPLIES).

- 3-45 **MASTER/SLAVE PARALLEL CONNECTION.** Two power supplies are shown in FIG. 3-14, although more can be paralleled, each unit requiring its own sampling resistor. The sampling resistors (R_{s1} , R_{s2} in FIG. 3-14) are of equal value and are selected such that the voltage drop across them (due to the output current), plus the voltage drop in the load connection leads does never exceed 0.5 volts. If the voltage drop across the load connecting leads alone is at least 0.1 volt, the sensing resistors can be deleted since the leads provide the necessary sample voltage. For equal current sharing, however, the lead *length* and *diameter* should be the same for both power supplies. Output control is exercised from the "Master" supply.
- 3-46 **PROCEDURE FOR "MASTER/SLAVE" PARALLEL OPERATION** (See FIG. 3-14)
- 1) Connect the power supplies to be paralleled to a common a-c source (preferably with a common "on-off" power switch).
 - 2) Make all load and sensing connections as shown in FIG. 3-14. The error sensing connections may be deleted if the minor voltage drop across the load wires (which subtracts from the available compliance voltage) can be tolerated.
 - 3) With the *individual* a-c power switches of the two power supplies in the "on" position, turn the *common* a-c power switch "on". Observe output panel meters on both powers supplies. Adjust output control on the "Master" supply, such that both supplies share the load current equally.

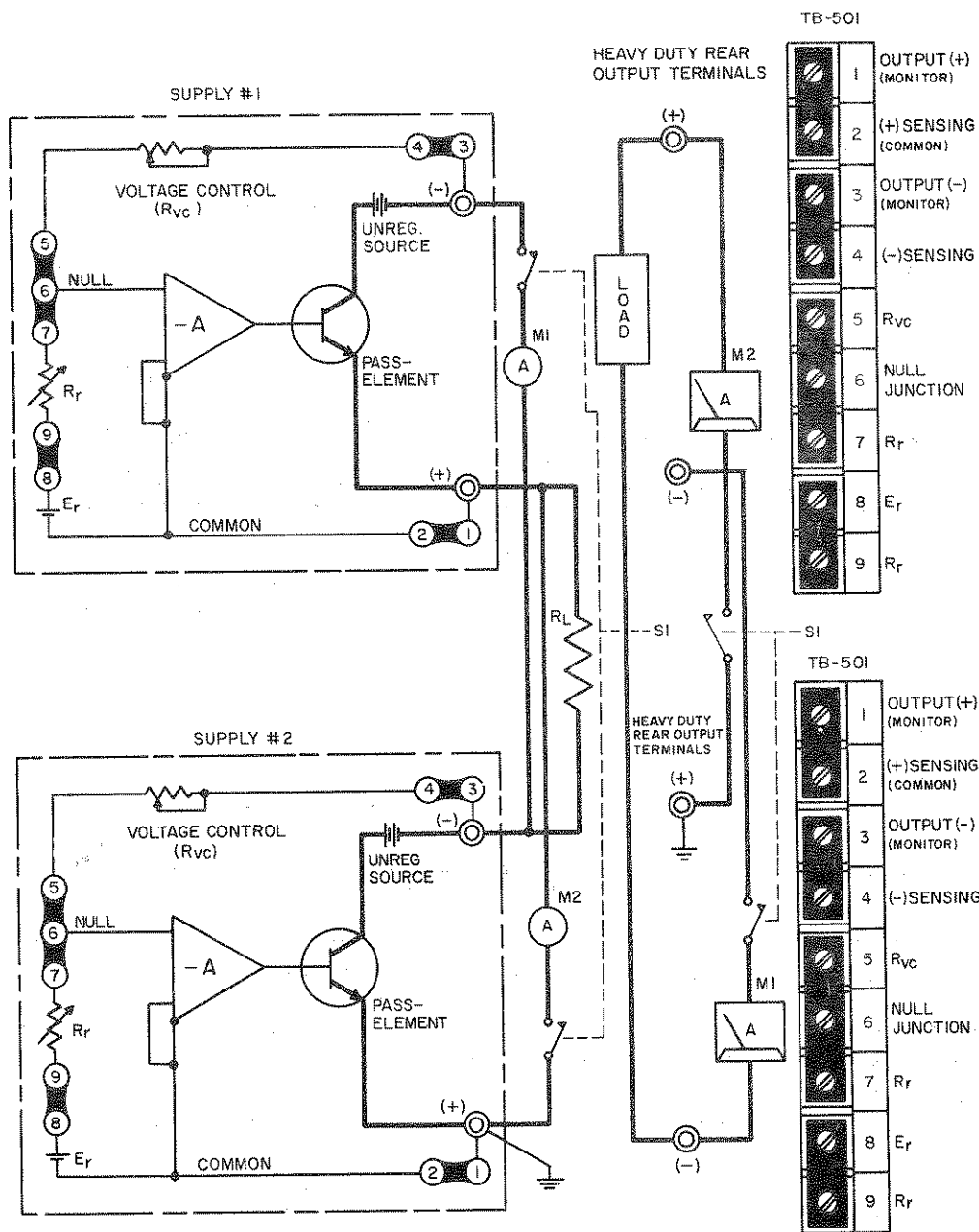

FIG. 3-13 BASIC PARALLEL CONNECTION OF TWO KEPCO POWER SUPPLIES

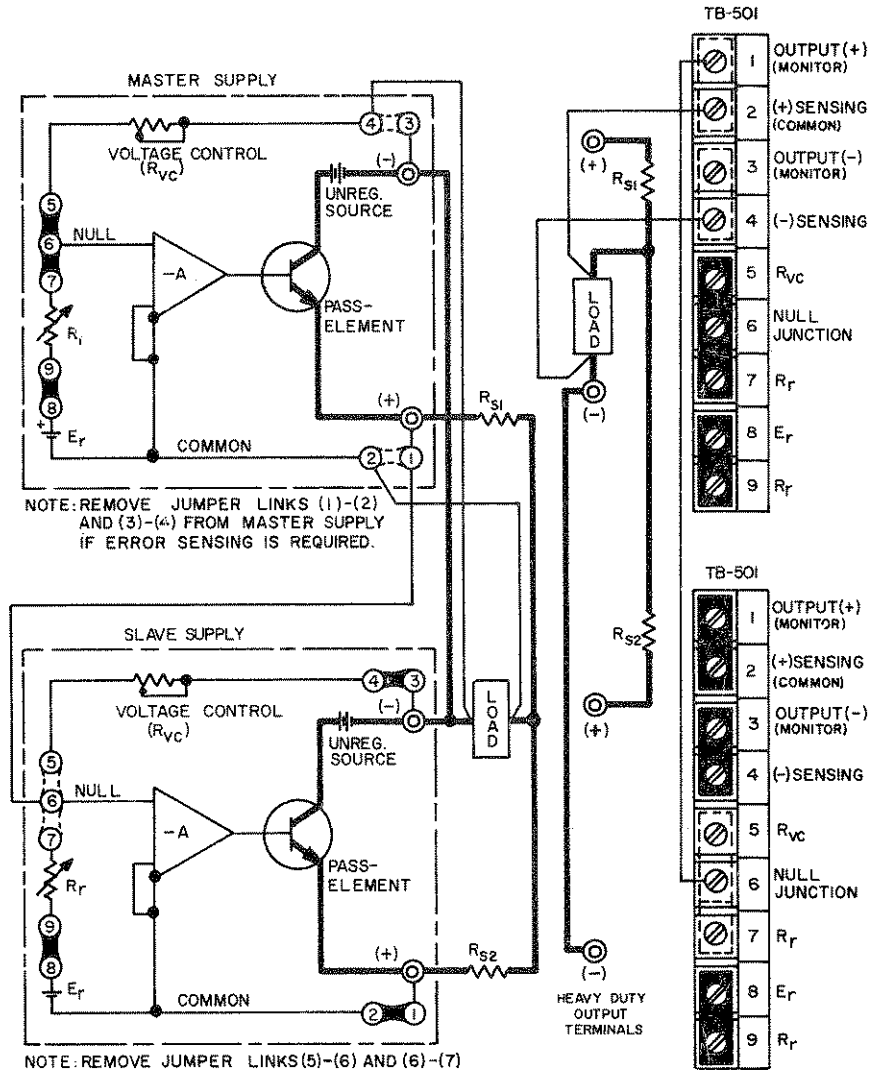

FIG. 3-14 MASTER SLAVE PARALLEL CONNECTION OF KEPKO POWER SUPPLIES

SECTION IV – THEORY OF OPERATION

(References in CAPITAL LETTERS refer to the nomenclature used in FIG. 4-1)

4-1 SIMPLIFIED DIAGRAM DISCUSSION (Refer to FIG. 4-1)

- 4-2 The MAIN POWER TRANSFORMER converts the line voltage to the required levels needed to produce the DC operating voltages for the MAIN AND AUXILIARY SUPPLIES. The MAIN POWER SUPPLY is in series with the PASS ELEMENTS and the CURRENT SENSING RESISTOR and produces the output voltage. The MAIN PASS ELEMENTS are changing their series resistance in a way tending to keep the OUTPUT VOLTAGE constant. The necessary drive for this change is produced by the DRIVER CIRCUIT which in turn receives its command signals either from the CURRENT LIMIT AMPLIFIER or the ERROR SIGNAL AMPLIFIER.
- 4-3 The OUTPUT VOLTAGE is constantly compared to the REFERENCE SOURCE, while the output current is monitored by the CURRENT SENSING resistor. Any change, in either output voltage or current, is amplified by the associated amplifier and transferred to the GATE DIODES which feed directly into the DRIVER CIRCUIT and produce the needed drive signal for the MAIN PASS ELEMENTS, thus either keeping the OUTPUT VOLTAGE constant, or if the signal from the CURRENT LIMIT AMPLIFIER is dominant, limiting the output current to the pre-adjusted value.
- 4-4 The OVERVOLTAGE PROTECTOR (Optional, on models with suffix "VP" only.) is connected across the output terminals of the power supply. A portion of the output voltage is continuously compared to an internal reference. If an overvoltage occurs, the S.C.R. "crowbar" will short-circuit the output immediately. Recycling takes place automatically, since the AC input power is removed by the tripping of the circuit breaker.

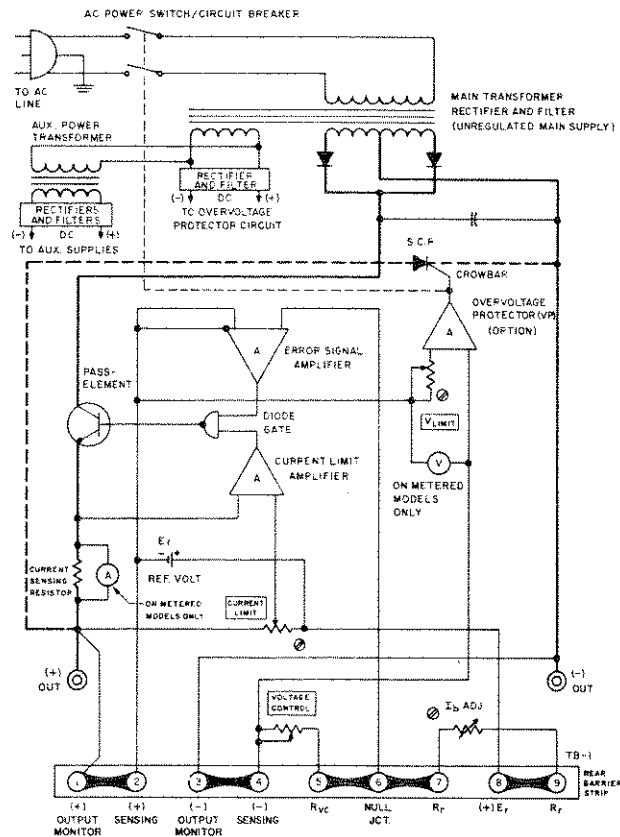

FIG. 4-1 SIMPLIFIED DIAGRAM, JQE HALF-RACK POWER SUPPLY

4-6 For the purpose of analysis, the circuitry of the JOE power supply may be divided into several sections which are individually described below. The main schematic (FIG. 6-3) should be used to illustrate the text of this section.

- a) **AC INPUT CIRCUIT.** AC line power is introduced through the AC input barrier-strip or a heavy duty three-wire line cord (removable) with safety plug.* The use of a grounded AC power outlet will automatically ground the power supply, since the third wire of the line cord is directly connected to the metal chassis and case. Once the AC POWER SWITCH/CIRCUIT BREAKER (CB101) is closed, the primary of the main transformer (T201), the fan (B201) and the AC pilot light (DS101)* will be energized. The two primary windings of the main transformer are either connected in parallel (for 115V AC nominal line voltage) or in series (for 230V AC nominal line voltage). The AC POWER SWITCH/CIRCUIT BREAKER (CB101), aside from switching the AC primary power, has the function of disconnecting the power supply from the AC line in case of overloads or short circuits. CB101 has two sensing coils, one of which is always in series with one of the primary windings on T201 (T2–T5), whether the main transformer is wired for 115V or for 230V AC. The second sensing coil of CB101 is in series with the secondary winding on T201 which generates the working potential for the overvoltage protection circuit (T201–T6,T7). If an overload occurs, due to either internal component failure or crowbar action of the voltage protector (Models with suffix "VP" only), the coil is energized sufficiently to activate the trip-mechanism of CB101, thus disconnecting the power supply from the AC line. Since the primary coil of the AUXILIARY POWER TRANSFORMER (T202) is in parallel with the secondary for the overvoltage protection circuit, any failure in the auxiliary circuits, reflecting back to the primary of the auxiliary power transformer (T202) will also activate the sensing coil of CB101 and shut down the power supply. A thermal sensing element (S301) is mounted to the HEATSINK ASSEMBLY (A3) to protect the series regulator transistors from over-temperature. If the pre-set temperature on S301 is exceeded, its contact close and energize the sensing coil of CB101, resulting once more in the tripping of the AC POWER SWITCH/CIRCUIT BREAKER and subsequent removal of the AC input power from the power supply.
- b) **MAIN DC SUPPLY.** The main DC power is derived from a center-tapped secondary winding on T201. A full-wave rectifier circuit with silicon diodes (CR301,302 if located on A3, CR201,202 if located on main chassis A2) operates into a capacitor input filter (C201,202 on some models; C201,202,203 on others) which is paralleled by a bleeder resistor (R202). The main DC supply delivers the output current via the series regulator or pass-elements.
- c) **PASS-ELEMENT SECTION.** The pass-element section in the JOE Power Supply varies in complexity according to the output voltage and current rating of the particular model. The NPN silicone pass-transistors of the JOE are located on high-efficiency heatsinks and are cooled by a fan (B201). Some JOE models have single heatsink assemblies (A3) with pass-transistors Q301 to Q3... , the number depending on the individual model. Other JOE models have dual heatsink assemblies (A3 and A6) with pass-transistors Q301 to Q3... and Q601 to Q6... , the number of transistors again depending on the individual model. While in the low voltage/high output current models ($E_o \leq 36$ volts) all pass-transistors are arranged in a parallel circuit, higher voltage models ($E_o > 36$ volts) use a series/parallel configuration in the arrangement of their pass-transistors. In the latter, a "master/slave" circuit is used, where the "slave" section is sometimes paralleled by power resistors, which share in the power dissipation if the power supply is operating in the current-limit mode or under short-circuit conditions. However complex the pass-element section, for analytical purposes it can be reduced to a single pass-transistor. Electrically, this pass-transistor is part of a series circuit consisting of the unregulated main DC power supply, the external load and the pass-transistor. The output voltage of the power supply is kept constant, regardless of variations in the unregulated supply, by changing the series resistance of the control element (the pass-transistor) in the described series circuit. The necessary base-drive for the pass-transistors to affect the change in series resistance is supplied by the "Darlington" connected driver stages. The main driver stages in turn receive their base signals from the pre-driver stage (Q2) of the error-signal amplifier.

*Line cord and AC pilot light used on metered models (suffix "M") only. Unmetered models have an AC input barrier-strip. The terminal marked "G" on this barrier-strip is connected directly to the chassis and must be returned to AC ground.

- d) **ERROR SIGNAL AMPLIFIER (A_V)**. The main function of this DC amplifier is to amplify the error signal, derived from the comparison bridge, to a level suitable to pass the diode gate circuit and drive the pre-driver stage (Q2). The error signal amplifier in the JOE power supply is a DC coupled, high gain operational amplifier in a plug-in package. The amplifier input may be disconnected from the comparison bridge circuit, and programmed externally. Although the plug-in amplifier is used in the non-inverting configuration, a positive input signal will produce a negative power supply output with respect to the "common" (plus (+) sensing terminal), since the pass-elements provide another signal inversion.
- e) **COMPARISON BRIDGE**. This four-arm electrical bridge circuit is the sensing and controlling element in the JOE power supply. The reference-half of the bridge consists of the reference resistors in series with the zener reference voltage ($R_r = R4, R8$; $E_r = CR3$), the other half is constituted by the voltage control resistor ($R_{VC} = R102$) and the output voltage (E_O). The simplified presentation shown in Section III of this manual will illustrate this discussion and show the actual bridge configuration. (Refer to FIG. 3-3). The output voltage (in series with R_{VC}) is continuously compared with the reference half of the bridge circuit. At bridge balance ($E_{AA'} = 0$), a constant bridge current (I_B) is flowing through the bridge, keeping the error signal at the bridge terminals (A,A') at approximately zero volts. Any deviation in the output voltage (E_O), caused either by line/load variation or by a change in R_{VC} will tend to change the bridge current (I_B) in the sensing half of the bridge and thereby produce an error signal at the bridge terminals (A,A'). The error signal is presented to the amplifier input and will after amplification, act as a drive for the pass transistors, changing the voltage drop (E_D) across them in such a way as to restore bridge balance and keep the output voltage (E_O) constant once more.
- f) **CURRENT LIMIT CIRCUIT**. The differential input of the current limit amplifier (Q4,Q5) is connected to the current sensing resistor ($R_S = R203$) and to a reference voltage, adjustable by the current limit control (R101). The voltage drop across the current sensing resistor is thus continuously compared to the reference voltage, set by the current limit control. As long as the voltage developed across R_S (due to load current flow) is less than the pre-set voltage reference level, the current limit amplifier will be biased to its inactive state and will not effect the output. If the output current increases however, the voltage drop across R_S will overcome the reference level set by the current limit control. The current limit amplifier will be thus activated and produce a drive signal at the diode gate, greater than A_V , thereby taking control away from the error signal amplifier and transferring the power supply into the current limit mode. Since both, the current limit amplifier and the error signal amplifier (A_V) are coupled through the diode gate circuit (CR14,15) to the pre-driver stage (Q2), the amplifier with the greater (negative) output will control the pass transistors and therefore the output.
- g) **OVERVOLTAGE PROTECTION CIRCUIT (A4, contained in Models with suffix—"VP")**
- 1) Input and output connections for the overvoltage protection circuit (VP) are made via a single printed circuit board connector (P401) and its associated mating plug. The VP contains its own auxiliary power supply with only the AC voltage derived from a secondary of the main transformer (T201) and introduced via P401/J207. The AC is rectified by a conventional bridge rectifier (CR401), capacitor filtered by the input filter capacitor (C401) and shunt regulated by a zener diode (CR405). A six volt source is derived from the pre-regulated DC voltage by means of another zener diode (CR406) thus providing a stable reference source (E_{ref}).
 - 2) The overvoltage protection circuit contains a dual input Schmitt-Trigger (Q402,403) in a voltage comparison configuration. A fixed part of the reference voltage (E_{ref}) is applied to the "reference input" (Base of Q402), and a portion of the power supply output voltage (E_O) to the "sensing input" (Base of Q403), so that the ratio E_O/E_{ref} is continuously sampled. Adjustment of the "Voltage Limit" controls (R414,R415), connected as a part of the voltage divider on the "sensing input" keeps the ratio E_O/E_{ref} constant, as the power supply output voltage is varied throughout the specified range (3V to E_O max. rated). The inputs to the Schmitt Trigger are thus balanced and the circuit is inactive.
 - 3) In the event of an overvoltage, resulting either from external causes or from internal power supply failure, the circuit become active. Since the "reference input" of the Schmitt Trigger is rigidly clamped to a fixed reference, a positive input at the "sensing input" (due for example to an overvoltage) will result in a change of state in Q402, producing an output pulse. The output

pulse from the Schmitt Trigger stage, transferred via the emitter follower (Q401) is applied to the first S.C.R. (CR402). The charging time constant at the output of the Schmitt Trigger stage is determined by the value of the (adjustable) delay capacitor (C403). In effect, the setting of C403 determines the "sensitivity" to overvoltage of the protection circuit. Minimum capacity will yield faster response but will also make the circuit more sensitive to spurious triggering. The control is factory set for fastest response consistent with stable operation under all conditions.

- 4) As the first S.C.R. (CR402) is conducting due to the pulse from the Schmitt-Trigger, it performs two functions: It shorts out the DC supply for the voltage protection circuit, thereby creating an over current in one of the circuit breaker coils. Simultaneously, CR402 generates a firing pulse for the main S.C.R. (CR203), which through its "crowbar" action short-circuits the power supply output. The AC POWER SWITCH/CIRCUIT BREAKER (CB101) trips due to the action of the first S.C.R. (CR402), disconnecting the power supply from the power line. The protection circuit is automatically re-activated with the "turn-on" of the power supply via CB101.

h) AUXILIARY SUPPLIES

- 1) AMPLIFIER POWER SUPPLY. This full wave, bridge rectified source is derived from a secondary winding on the auxiliary transformer (T202). Rectified by CR8, the supply is capacitor filtered by C2. A current regulator stage (Q3), followed by a string of zener diodes (CR10-13), provides the operating voltage for the error signal amplifier (A_v), the current limit amplifier stage (Q4,Q5) and the reference circuit (R4,R8,CR3).
 - 2) PRE-DRIVER COLLECTOR SUPPLY. A half wave rectified (CR3) and capacitor filtered (C2) supply is derived from a secondary winding on T202. It delivers collector voltage to the pre-driver stage (Q2).
 - 3) ICBO SUPPLY. This full-wave rectified auxiliary supply is derived from the winding of the auxiliary power transformer. Rectified by CR1 and filtered by C1, constant current is applied to the base of the pass transistors (Via the constant current generator stage (Q1), thus insuring the necessary turn-off bias for these stages under all operating conditions, especially at elevated temperatures.
- i) METERING CIRCUIT (models with suffix "M" only). Both output voltage and output current are monitored by dual range front panel meters (M101,102). The two meter ranges are 0 to 10% and 0 to 100% of the rated output voltage and output current and may be selected by meter range switches (S101 for voltage, S102 for current) located between the front panel meters. While the output voltage is measured directly across the error sensing terminals (TB501-2, TB501-4), the output current is measured indirectly as a voltage drop across the current sensing resistor (R203).

SECTION V – MAINTENANCE

5-1 GENERAL

5-2 This section covers maintenance procedures, installation of optional components, calibration and test measurements of the Kepco Model JQE Power Supplies. Conservative rating of components and the non-congested lay out should keep maintenance problems to a minimum. If trouble does develop however, the easily removed wrap-around cover and the plug-in feature of the circuit boards provide exceptional accessibility to all components of the supply.

5-3 DISASSEMBLY (Refer to FIG. 5-1)

- a) COVER REMOVAL. The wrap-around cover may be taken off by loosening and removing its twelve (12) holding screws, five (5) on each side and two (2) on the front panel.
- b) CIRCUIT BOARD REMOVAL. The printed circuit board is mounted with two (2) screws, which are removed from the side. After removal of the four printed circuit board connectors, the board may be lifted from its slide-guide.
- c) HEAT SINK REMOVAL. The heat sink assembly is mounted with four (4) screws to the chassis bottom. After the screws are taken out, the wires may be removed by means of the "quick disconnect" terminals.
- d) OVERVOLTAGE PROTECTOR (A4) REMOVAL. (On Models with Suffix—"VP" only). Remove the holding screw as indicated (Refer to FIG. 5-1) and lift assembly out.
- e) RE-ASSEMBLY. Re-assembly of all components takes place in reverse order of the above described procedures.

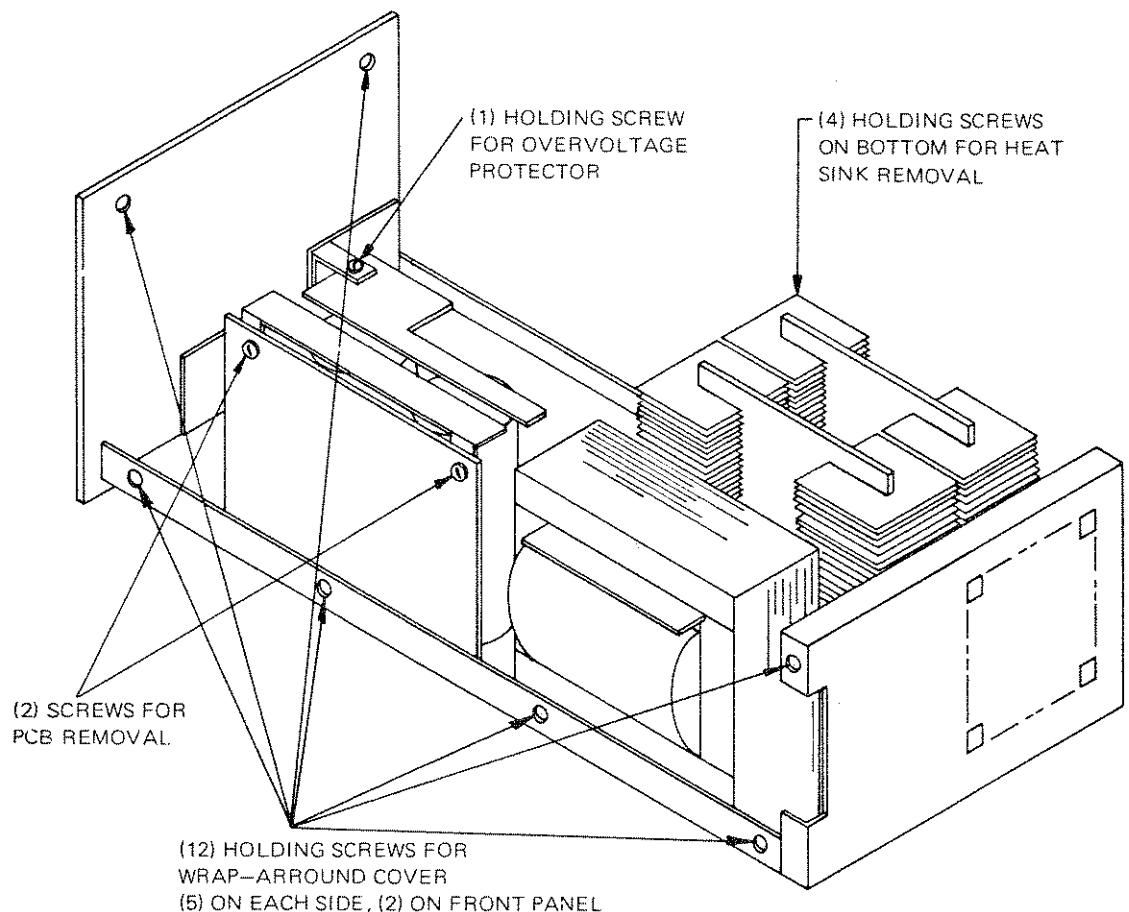

FIG. 5-1 DISASSEMBLY, JQE HALF-RACK MODELS

5-4 INTERNAL ADJUSTMENT PROCEDURES

5-5 GENERAL. This paragraph describes all internal adjustment procedures, which have not been previously covered. Refer to Section II, paragraph 2-3, for a listing and location of all adjustment procedures.

5-6 MAXIMUM OUTPUT CURRENT (" I_O max. adj.") ADJUSTMENT. This adjustment serves as a calibration for the range of the front panel Current Limit Control. The " I_O max. adj." (R19) is located on the printed circuit board (Refer to FIG. 2-1). It is factory set so that the front panel control covers an output current range of 2–105% of the maximum rated output current. Re-adjustment of the " I_O max. adj." control is needed only if a component in the current limit circuitry must be replaced or, if the range of the front panel control is to be restricted. A convenient way to make the adjustment is as follows:

- Load the output of the supply to draw the maximum desired output current with the front panel Current Limit Control fully clockwise. Monitor the output voltage with an oscilloscope, having a vertical sensitivity of at least 0.1 mV/cm.
- Observe the oscilloscope. Current limiting is indicated by a sharp increase in output ripple. Locate the " I_O max. adj." control and turn slowly until limiting occurs at the point required. Clockwise adjustment will increase the maximum output current range, while counter clockwise adjustment will decrease the range. DO NOT ADJUST TO MORE THAN 105% I_O max. Although this might be possible due to component tolerances, malfunction of the power supply will be caused by exceeding the rated maximum output current.

5-7 LAG NETWORK ADJUSTMENTS. Depending on the JOE model designation, either one or two AC stability controls in the form of lag networks have been provided in this power supply (R16-C9 and/or R36-C10, see main schematic, FIG. 6-3). These networks have been factory adjusted for maximum amplifier stability when operating into a resistive load. Re-adjustment is indicated if components, affecting the AC characteristics of the amplifier must be replaced or, if the load connected to the power supply contains excessive capacity or inductance, causing AC instability. AC instability is usually indicated by high frequency oscillation as observed with an oscilloscope across the power supply load. In such cases, the lag networks should be adjusted so that stable operation is resumed. If in extreme cases adjustment of the lag networks should not prove sufficient, twisted load and error sensing wires or decoupling capacity directly across the load may provide a solution to the problem.

5-8 INSTALLATION AND ADJUSTMENT OF THE "ZERO" CONTROL *

NOTE: Models which have this control factory installed carry the suffix "E" behind their model number (i.e. JOE 6–10ME). The installation instructions may be disregarded with these models.

5-9 A small (5–15mV), negative offset voltage exists at the output of the power supply, with the voltage control set to "zero" (fully counter clockwise). Although this does not affect standard power supply operation, for precision remote programming, exact zero volt output may be necessary. The zero can be established by adding the necessary control (" E_{iO} Null," to be designated R14) internally on a pre-designated space on the printed circuit board.

5-10 The installation may be readily accomplished by following the steps indicated below:

- Remove thy PCB Assembly from the chassis as described in paragraph 5-3. Locate the pre-designated space for the additional components on FIG. 5-2.
- Install " E_{iO} Null" (R14) control on the place indicated and solder in place.
- Remove old jumper and install in new place as shown.
- Adjust precision zero as described in paragraph 3-12.

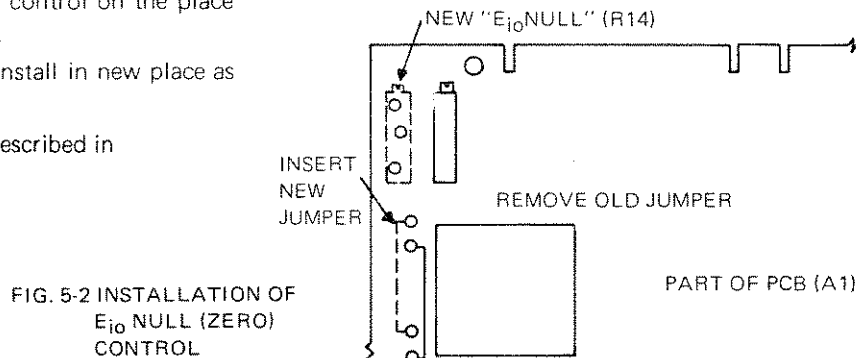

FIG. 5-2 INSTALLATION OF E_{iO} NULL (ZERO) CONTROL

*These instructions are applicable for Models JOE 6–45(M) and JOE 15–25(M) only.

5-11 TROUBLE SHOOTING

- 5-12 Modern, high performance power supplies have reached a state of sophistication that requires thorough understanding of the problems involved in repairing complex, solid state circuitry. Servicing beyond simple parts replacements should consequently be attempted only by personnel thoroughly familiar with solid state component techniques and with experience in closed loop circuitry.
- 5-13 Trouble shooting charts, showing resistance and voltage readings, are of very limited usefulness with feedback amplifiers and are not included here. Instead a detailed circuit description (Section IV), parts location diagrams, simplified functional schematics and a main schematic with all significant voltage readings is presented.
- 5-14 The following basic steps in a case of power supply malfunctioning may also be found useful:
- a) If power supply does not function at all: Check all powerline connections and fuses and make certain, power supply is connected to the correct line voltage (it is normally delivered for 115V AC operation).
 - b) No DC Output:
 - 1) Check rear barrier-strip jumper connection for correct placement and tight seat (Refer to FIG. 4-1).
 - 2) Check the correct placement and tight seat of all transistors on the amplifier board (Refer to the component location drawings and parts list in Section VI).
 - 3) Check reference voltage from terminal (2) to (8) on the rear barrier strip. Correct reference potential is 6.2V nominal.
 - 4) Check amplifier supply voltages from the "0 V DC" buss. (Refer to Main Schematic, FIG. 6-3)
 - 5) Test amplifier transistors* Q2, Q3, Q4.
 - c) HIGH DC OUTPUT: If the output voltage is high and not controllable by the voltage control, identical steps as outlined above (par. 5-14b) are advisable. In addition, if the condition persists, check the following:
 - 1) Check the pre-driver transistor* (Q1) and the main driver (Q305) as well as all pass-elements (Q301-3..., the number of pass-elements depends on the individual model).
 - 2) Check the voltage control resistor (R102) for continuity. Monitor output with an oscilloscope and observe ripple wave-form and amplitude. If high frequency oscillations are observed proceed as directed below. (Refer to par. 5-14e). High 60 Hz ripple is often due to failure in one of the rectifier circuits. Measure the operating voltages under the conditions specified in the main schematic (FIG. 6-3).
 - d) If supply does not function in one of the remote programming modes, disconnect all external components and reconnect internal reference and the voltage control. The following paragraphs refer to the instrument as a power supply, rather than an amplifier in order to simplify test set-ups and measurements.
 - e) If the power supply is basically functioning, but poor performance is evident, inspect the test set-up to make certain the source of the trouble is not external.
 - f) Excessive output variations in any of the operating modes are usually traceable to incorrectly connect loads or faulty measurement techniques. Perform measurements as described in paragraph 5-16 and follow the connecting diagrams.
 - g) Oscillation of the output voltage or output current is often due to a load with a large inductive component. Twisted loadwires of sufficient diameter and held as short as practical, are often the solution to the problem, if lag network adjustment does not correct the trouble. (Refer to par. 5-7).
- 5-15 KEPCO Field Engineering Offices or the KEPCO Repair Department will be available for consultation or direct help in difficult service or application problems.

*NOTE: If a transistor checker is not available, transistors may be checked for shorts by means of an ohmmeter. Check between emitter and collector and reverse polarity of the ohmmeter. One reading should be high, the other low, the ratio being about 1:4.

5-16 POWER SUPPLY MEASUREMENTS

5-17 Measurement of the significant parameters of a power supply is a requirement for incoming inspection, periodic maintenance, or after component replacement. Since the measurements require special techniques to insure correct results, suggestions for their performance are given below:

- a) Required Instrumentation:
 - 1) Constant AC source voltage with provisions for "stepping" the voltage over a specified region (105–125V); a variable autotransformer is generally adequate, if it is rated to deliver the input current of the unit under test.
 - 2) Resistive load, variable, with ON/OFF and SHORTING SWITCH and capable of dissipating the full output power of the unit under test.
 - 3) DC voltage monitor, differential voltmeter, or power supply analyzer.
 - 4) Current sensing resistor, for measurements of output effects in the current mode, 4-terminal device.
 - 5) AC ripple monitor, sensitivity better than 1 mV, Ballantine Model 302C or Hewlett Packard Model 400H.
 - 6) Optional: Oscilloscope, vertical sensitivity better than 0.1 mV/cm.
- b) FIG. 5-3 shows the proper location of instrument leads when measuring output effects. The principle governing this method of measurement is simply: DO NOT MEASURE ANY VOLTAGE DROPS DUE TO LOAD CURRENT FLOW. This can only be avoided by measuring output effects either directly at the sensing leads or by the use of 4-terminal network. The 4-terminal network can be approximated by the method shown in FIG. 5-3d.
- c) Output effects due to source or load variations in the voltage mode are defined as the amount of output voltage change resulting from a specified change of line voltage or from a change in load resistance. It can be expressed as an absolute change ΔE_O or as a percentage in reference to the total output voltage E_O :

$$\% \text{ Output Effect} = \frac{\Delta E_O}{E_O} \times 100\%$$

- d) Output effects due to source or load variations in the current mode are defined as the amount of output current change resulting from a specified change in line voltage or from a change in load resistance. It can be expressed as an absolute change ΔI_O , or as a percentage in reference to the total output current I_O :

$$\% \text{ Output Effect} = \frac{\Delta I_O}{I_O} \times 100\%$$

- e) RMS ripple may be monitored on a true RMS reading instrument connected parallel to the regulation analyzer leads. Careful wire dressing and shielding, as well as good AC grounding are of the utmost importance if valid measurements are expected. An oscilloscope may also be used for P-P readings of noise and ripple. An approximate RMS reading can be calculated from the P-P reading of the oscilloscope if the reading is divided by three.

TO DIGITAL OR DIFFERENTIAL
VOLTMETER, TO MEASURE ΔE_o
AS S1 IS OPENED OR CLOSED

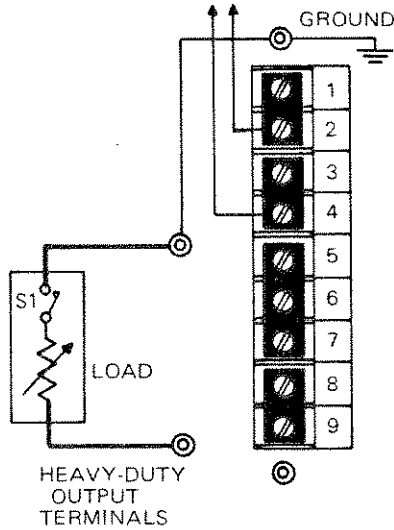

a) OUTPUT EFFECT MEASUREMENT
(VOLTAGE) WITHOUT ERROR SENSING

TO DIGITAL OR DIFFERENTIAL
VOLTMETER, TO MEASURE ΔE_o
AS S1 IS OPENED OR CLOSED

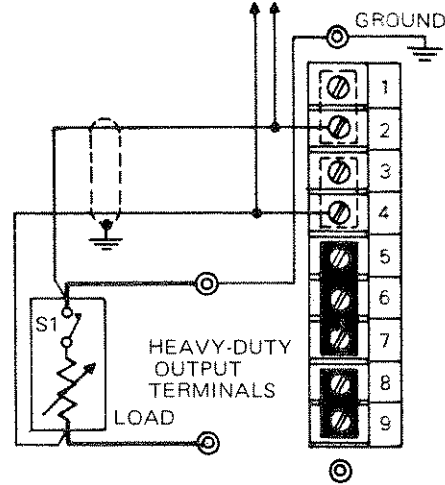

b) OUTPUT EFFECT MEASUREMENT (VOLTAGE)
WITH ERROR SENSING AT THE LOAD

TO DIGITAL OR DIFFERENTIAL
VOLTMETER, TO MEASURE ΔV_{RS}
AS S1 IS OPENED OR CLOSED

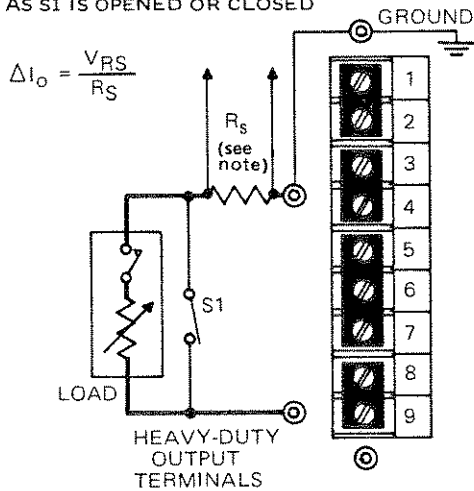

c) OUTPUT EFFECT MEASUREMENT (CURRENT)
NOTE: R_s should be selected such that its wattage rating
is at least 10 times the actual power dissipated.
Stability and regulation depend on the stability
of R_s . Recommended T.C. for R_s is 20 ppm.

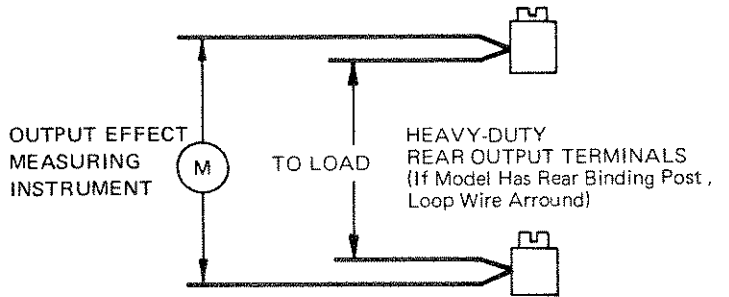

d) APPROXIMATION OF A FOUR-TERMINAL
NETWORK

FIG. 5-3 CONNECTIONS FOR POWER SUPPLY MEASUREMENTS

SECTION VI—ELECTRICAL PARTS LIST AND DIAGRAMS

6-1 GENERAL

6-2 This section contains the main schematic, the parts location diagrams, and a list of all replaceable electrical parts. All components are listed in alpha-numerical order of their reference designations. Consult your Kepco Representative for replacement of parts not listed here.

6-3 ORDERING INFORMATION

6-4 To order a replacement part or to inquire about parts not listed in the parts list, address order or inquiry either to your authorized Kepco Sales Representative or to:

KEPCO, INC.
131-38 Sanford Avenue
Flushing, N.Y. 11352

6-5 Specify the following information for each part:

- a) Model and complete serial number of instrument.
- b) Kepco part number.
- c) Circuit reference designator.
- d) Description.

6-6 To order a part not listed in the parts list, give a complete description and include its function and location.

NOTE: KEPCO DOES NOT STOCK OR SELL COMPLETE POWER SUPPLY SUBASSEMBLIES AS DESCRIBED HERE AND ELSEWHERE IN THIS INSTRUCTION MANUAL. SOME OF THE REASONS ARE LISTED BELOW:

- 1) Replacement of a complete subassembly is a comparatively rare necessity.
- 2) Kepco's subassemblies are readily serviceable, since most of them are of the "plug-in" type.
- 3) All active components are socket mounted, making replacement extremely easy.
- 4) The nature of a closed-loop power supply system requires that subassembly replacement is followed by careful measurement of the total power supply performance. In addition, depending on the function of the subassembly, extensive alignment may be required to restore power supply performance to specified values.

IF REPAIRS INVOLVING SUBASSEMBLY REPLACEMENTS ARE REQUIRED, PLEASE CONSULT YOUR LOCAL KEPCO REPRESENTATIVE OR THE KEPCO SALES ENGINEERING DEPARTMENT IN FLUSHING, NEW YORK, N.Y.

ABBREVIATIONS USED IN KEPCO PARTS LISTS

A) Reference Designators:

A	= Assembly	L	= Inductor
B	= Blower (Fan)	LC	= Light-Coupled Device
C	= Capacitor	M	= Meter
CB	= Circuit Breaker	P	= Plug
CR	= Diode	Q	= Transistor
DS	= Device, Signaling (Lamp)	R	= Resistor
F	= Fuse	S	= Switch
FX	= Fuse Holder	T	= Transformer
IC	= Integrated Circuit	TB	= Terminal Block
J	= Jack	V	= Vacuum Tube
K	= Relay	X	= Socket

B) Descriptive Abbreviations

A	= Ampere	MET	= Metal
a-c	= Alternating Current	n	= Nano (10 ⁻⁹)
AMP	= Amplifier	NC	= Normally Closed
AX	= Axial	NO	= Normally Open
CAP	= Capacitor	p	= Pico (10 ⁻¹²)
CER	= Ceramic	PC	= Printed Circuit
CT	= Center-Tap	POT	= Potentiometer
°C	= Degree Centigrade	PIV	= Peak Inverse Voltage
d-c	= Direct Current	p-p	= Peak to Peak
DPDT	= Double Pole, Double Throw	ppm	= Parts Per Million
DPST	= Double Pole, Single Throw	PWR	= Power
ELECT	= Electrolytic	RAD	= Radial
F	= Farad	RECT	= Rectifier
FILM	= Polyester Film	RECY	= Recovery
FLAM	= Flammable	REG	= Regulated
FP	= Flame-Proof	RES	= Resistor
°F	= Degree Fahrenheit	RMS	= Root Mean Square
FXD	= Fixed	Si	= Silicon
Ge	= Germanium	S-End	= Single Ended
H	= Henry	SPDT	= Single Pole, Double Throw
Hz	= Hertz	SPST	= Single Pole, Single Throw
IC	= Integrated Circuit	Stud Mt	= Stud Mounted
K	= Kilo (10 ³)	TAN	= Tantalum
m	= Milli (10 ⁻³)	TSTR	= Transistor
M	= Mega (10 ⁶)	μ	= Micro (μ) (10 ⁻⁶)
MFR	= Manufacturer	V	= Volt
		W	= Watt
		WW	= Wire Wound



REPLACEMENT PARTS LIST

AMPLIFIER BOARD ASSEMBLY (A1), MODEL JOE 6-22 (M) (E) (T)

Coed 9-269

SCHEMATIC NO.	QTY.	DESCRIPTION	MFRS. NAME & PART NO. (SEE NOTE)	KEPCO PART NO.
A _v	1	Plug-In Amplifier	Kepeco 250-0013	250-0013
C1	1	Capacitor,Electrolytic,Pigtail 150 μF, 25 V	Sprague 30D157G025DF0	117-0713
C2	1	Capacitor,Electrolytic,Pigtail 75 μF, 50 V	Sprague 30D756G050DF2	117-0646
C3,4	2	Capacitor,Electrolytic,Pigtail 150 μF, 3 V	General Electric 76F02BF151	117-0512
C5	1	Capacitor,Mylar,Pigtail 0.1 μF, 600 V	TRW X663F	117-0316
C6	1	Capacitor,Mylar,Pigtail 1 μF, 200 V	Wesco 33MM	117-0395
C7	1	Capacitor,Electrolytic,Pigtail 290 μF, 12 V	Sprague 30D297G012DF2	117-0647
C8	1	Capacitor,Mylar,Pigtail 0.01 μF, 200 V	Sprague 192P10302	117-0353
C9	1	Capacitor,Mylar,Pigtail 0.05 μF, 200 V	TRW X663F	117-0315
CR1,6,8	3	Rectifier,Silicon,Bridge,Pigtail	Varo VE-28	124-0346
CR2,9,10, 12,13	5	Zener Diode	Transitron 1N763-1	121-0028
CR3,11	2	Zener Diode	International Rectifier 1N821	121-0041
*CR3	1	Zener Diode	International Rectifier 1N827	121-0062
CR4,5	2	Rectifier,Silicon,Pigtail	EDI CEC1000	124-0178
CR7,14,15	3	Rectifier,Silicon,Pigtail	Semtech SE-1	124-0133
CR16	1	Rectifier,Silicon,Pigtail	Semtech SE-4	124-0028
**CR17	1	Zener Diode	International Resistance 1N821	121-0041
Q1	1	Transistor,NPN	RCA 40250	119-0068
Q2,3	2	Transistor,NPN	M.S. Transistor 119-0094	119-0094
Q4,5	2	Transistor,NPN	General Electric 2N336A	119-0056
R1	1	Resistor,Fixed,Molded 120 ohm, 1 W, 5%	Allen Bradley GB1215	115-0963
R2,20	2	Resistor,Fixed,M.G. 6.2 K ohm, 1/4 W, 5%	IRC RG 1/4	115-2258
R3	1	Resistor,Fixed,Molded 560 ohm, 1/2 W, 5%	Allen Bradley EB5615	115-0888
R4	1	Resistor,Variable,WW 1 K ohm, 1/2 W, 10%	Amphenol Controls Division 2600P-102	115-2264

*Models with suffix "T" only.

**Models with suffix "E" only.

NOTE:

REPLACEMENT PARTS MAY BE ORDERED FROM KEPCO, INC. ORDERS SHOULD INCLUDE KEPCO PART NUMBER AND DESCRIPTION.

PLEASE NOTE: THE MANUFACTURER'S NAME AND PART NUMBER LISTED FOR EACH ITEM ON REPLACEMENT PARTS LISTS, REPRESENTS AT LEAST ONE SOURCE FOR THAT ITEM AND IS LISTED SOLELY FOR THE CONVENIENCE OF KEPCO EQUIPMENT OWNERS IN OBTAINING REPLACEMENT PARTS LOCALLY. WE RESERVE THE RIGHT TO USE EQUIVALENT ITEMS FROM ALTERNATE SOURCES. KEPCO, INC.

8

9

10

11



REPLACEMENT PARTS LIST

AMPLIFIER BOARD ASSEMBLY (A1), MODEL JOE 6-22 (M) (E)

Code 9-269

SCHEMATIC NO.	QTY.	DESCRIPTION	MFRS. NAME & PART NO. (SEE NOTE)	KEPCO PART NO.
R5	1	Resistor,Fixed,Molded 560 ohm, 1/4 W, 10%	IRC GBT 1/4	115-2210
R6	1	Resistor,Fixed,Precision,M.F. 10 K ohm, 1/4 W, 1%	IRC CEA	115-2174
R7	1	Resistor,Fixed,Precision,M.F. 750 ohm, 1/4 W, 1%	IRC CEA	115-2259
R8	1	Resistor,Fixed,Precision,WW 5.7 K ohm, 1 W, 1%	Tepro TS-1W	115-1301
R9	1	Resistor,Fixed,Precision,M.F. 210 ohm, 1 W, 1%	IRC CES	115-1936
R10	1	Resistor,Fixed,M.G. 82 K ohm, 1/4 W, 5%	IRC RG 1/4	115-2011
R11	1	Resistor,Fixed,Molded 3.9 K ohm, 1/2 W, 5%	Allen Bradley EB3925	115-0808
R12,26	2	Resistor,Fixed,Molded 1 K ohm, 1/2 W, 5%	Allen Bradley EB1025	115-0340
*R13	1	Resistor,Fixed,Molded 1.3 K ohm, 1/4 W, 10%	IRC GBT 1/4	115-2379
**R14	1	Resistor,Variable,Trimpot,Cermet 100 K ohm, 3/4	Bourns 3009P-1-104	115-2399
*R15	1	Resistor,Fixed,Precision,M.F. 40.2 K ohm, 1/4 W, 1%	IRC CEA	115-2391
* *R15	1	Resistor,Fixed,Precision,M.F. 10 K ohm, 1/4 W, 1%	IRC CEA	115-2174
R16	1	Resistor,Variable,Cermet 500 ohm, 3/4 W, 10%	Bourns 3009-1-501	115-2398
R17	1	Resistor,Fixed,Molded 47 ohm, 1/4 W, 10%	IRC GBT 1/4	115-2273
R18	1	Resistor,Fixed,Molded 47 K ohm, 1/4 W, 10%	IRC GBT 1/4	115-2237
R19	1	Resistor,Variable,Cermet 20 K ohm, 3/4 W, 10%	Bourns 3009-1-203	115-2393
R21	1	Resistor,Fixed,Molded 12 K ohm, 1/4 W, 10%	IRC GBT 1/4	115-2276
R22	1	Resistor,Fixed,M.G. 36 K ohm, 1/4 W, 5%	IRC RG 1/4	115-2224
R23	1	Resistor,Fixed,Molded 27 ohm, 1/4 W, 10%	IRC GBT 1/4	115-2317
R24	1	Resistor,Fixed,Molded 510 ohm, 1 W, 5%	Allen Bradley GB5115	115-0959
R25,27	2	Resistor,Fixed,Molded 10 ohm, 1/4 W, 10%	IRC GBT 1/4	115-2230
R28	1	Resistor,Fixed,Molded 1.2 K ohm, 1/2 W, 5%	Allen Bradley EB1225	115-1167
* *R29	1	Resistor,Fixed,Precision,M.F. 750 ohm, 1/4 W, 1%	IRC CEA	115-2259
* *R30,31	2	Resistor,Fixed,Precision,M.F. 43.2 K ohm, 1/4 W, 1%	IRC CEA	115-2380
R34	1	Resistor,Fixed,Precision,M.F. 210 ohm, 1/4 W, 1%	IRC CEA	115-2177

*Delete for Models with suffix "E".

**Models with suffix "E" only.

NOTE:

REPLACEMENT PARTS MAY BE ORDERED FROM KEPCO, INC. ORDERS SHOULD INCLUDE KEPCO PART NUMBER AND DESCRIPTION.

PLEASE NOTE: THE MANUFACTURER'S NAME AND PART NUMBER LISTED FOR EACH ITEM ON REPLACEMENT PARTS LISTS, REPRESENTS AT LEAST ONE SOURCE FOR THAT ITEM AND IS LISTED SOLELY FOR THE CONVENIENCE OF KEPCO EQUIPMENT OWNERS IN OBTAINING REPLACEMENT PARTS LOCALLY. WE RESERVE THE RIGHT TO USE EQUIVALENT ITEMS FROM ALTERNATE SOURCES. KEPCO, INC.

6-5/6-6



REPLACEMENT PARTS LIST

MAIN CHASSIS AND FRONT PANEL ASSEMBLY (A2), MODEL JOE 6--22 (M)

Code 10-3069

SCHEMATIC NO.	QTY.	DESCRIPTION	MFRS. NAME & PART NO. (SEE NOTE)	KEPCO PART NO.
---------------	------	-------------	-------------------------------------	----------------

FRONT PANEL ASSEMBLY CONTAINS:

CB101	1	Circuit Breaker	Heinman JA2-A6A3	127-0272
*DS101	1	Pilot Light Assembly	Industrial Devices Glo-Dot 2100	152-0087
*M101	1	Meter 0-25A DC	Honeywell Model 504	135-0401
*M102	1	Meter 0-8V DC	Honeywell Model 504	135-0446
R101	1	Resistor, Variable, Composition 2 K ohm, 1/2 W, 30%	CTS VA-45	115-2268
R102	1	Resistor, Variable, WW 7 K ohm, 3 W, 3%	Bourns 3507	115-1257
*S102,103	2	Switch	Stackpole SS-72-1	127-0254

*Metered Models only.

B201	1	Motor	Howard Industries 32112	148-0027
C201,202	2	Capacitor, Electrolytic, Can 40 K μ F, 20 V	General Electric 86F1124MA	117-0718
C204	1	Capacitor, Electrolytic, Can 5.8 μ F, 20 V	General Electric 86F-500 Series	117-0714
CR201,202	2	Rectifier, Silicon, Stud	International Rectifier 40HF10	124-0355
*CR203	1	Silicon, Controlled, Rectifier (SCR)	International Rectifier 40RCS5	124-0322
CR204	1	Rectifier, Silicon, Pigtail	Semtech SE-4	124-0028
R201	1	Resistor, Fixed, Power, Axial 7.5 ohm, 5 W, 5%	Tepro TS-5W	115-0982
R202	1	Resistor, Fixed, Power, Axial 200 ohm, 3 W, 5%	Hardwick Hindle 9/16GA-46-200	115-0803
R203	1	Resistor, Fixed, Power, Shunt 0.02 ohm, 50 W, 1%	Tepro TMK-50W	115-2367
T201	1	Transformer	Kepeco Magnetics 100-1789	100-1789
T202	1	Transformer	Kepeco Magnetics 100-1790	100-1790

*Models with suffix "VP" only.

NOTE:

REPLACEMENT PARTS MAY BE ORDERED FROM KEPCO, INC. ORDERS SHOULD INCLUDE KEPCO PART NUMBER AND DESCRIPTION.

PLEASE NOTE: THE MANUFACTURER'S NAME AND PART NUMBER LISTED FOR EACH ITEM ON REPLACEMENT PARTS LISTS, REPRESENTS AT LEAST ONE SOURCE FOR THAT ITEM AND IS LISTED SOLELY FOR THE CONVENIENCE OF KEPCO EQUIPMENT OWNERS IN OBTAINING REPLACEMENT PARTS LOCALLY. WE RESERVE THE RIGHT TO USE EQUIVALENT ITEMS FROM ALTERNATE SOURCES.	KEPCO, INC.
------------------------------------------------------------------------------------------------------------------------------------------------------------------------------------------------------------------------------------------------------------------------------------------------------------------------------------	-------------

6-7/6-8



REPLACEMENT PARTS LIST

PASS-ELEMENT ASSEMBLY (A3), MODEL JOE 6-22(M)

Code 9-269

SCHEMATIC NO.	QTY.	DESCRIPTION	MFRS. NAME & PART NO. (SEE NOTE)	KEPCO PART NO.
Q301,302,303, 304,305,306	6	Transistor	Solitron 93SE114	119-0082
Q307	1	Transistor	RCA 40250	119-0068
R301,302,303, 304,305	5	Resistor,Fixed,Power,Axial 0.1 ohm, 3 W, 5%	Hardwick Hindle 9/16GA46-1	115-0819
R306	1	Resistor,Fixed,Molded 36 ohm, 1/2 W, 5%	Allen Bradley EB3605	115-2216
R307	1	Resistor,Fixed,Molded 120 ohm, 1/2 W, 10%	Allen Bradley EB1211	115-1136
R308	1	Resistor,Fixed,Molded 330 ohm, 1/2 W, 10%	Allen Bradley EB3311	115-0804
R309	1	Resistor,Fixed,Power,Axial 300 ohm, 3 W, 5%	Tepro TS-3W	115-0444
S301	1	Thermostat	Stemco 110486	127-0248

NOTE:

REPLACEMENT PARTS MAY BE ORDERED FROM KEPCO, INC. ORDERS SHOULD INCLUDE KEPCO PART NUMBER AND DESCRIPTION.

PLEASE NOTE: THE MANUFACTURER'S NAME AND PART NUMBER LISTED FOR EACH ITEM ON REPLACEMENT PARTS LISTS, REPRESENTS AT LEAST ONE SOURCE FOR THAT ITEM AND IS LISTED SOLELY FOR THE CONVENIENCE OF KEPCO EQUIPMENT OWNERS IN OBTAINING REPLACEMENT PARTS LOCALLY. WE RESERVE THE RIGHT TO USE EQUIVALENT ITEMS FROM ALTERNATE SOURCES. KEPCO, INC.

6-9/6-10



REPLACEMENT PARTS LIST

VOLTAGE PROTECTOR ASSEMBLY (A4), MODEL JOE 6-22 (M) VP

Code 10-3069

SCHEMATIC NO.	QTY.	DESCRIPTION	MFRS. NAME & PART NO. (SEE NOTE)	KEPCO PART NO.
C401	1	Capacitor, Electrolytic, Pigtail 140 μ F, 40 V	Sangmo 052FE141W040B	117-0706
C402	1	Capacitor, Mylar, Pigtail 0.05 μ F, 200 V	TRW X663F	117-0315
C403	1	Capacitor, Variable 80-480 pF, 175 V	Arco PC46	117-0637
C404	1	Capacitor, Mylar, Pigtail 0.0068 μ F, 200 V	TRW X663F	117-0552
CR401	1	Rectifier, Silicon, Bridge, Pigtail	Varo VE-28	124-0346
CR402	1	Rectifier, Controlled, Silicon (SCR)	Motorola 2N4441	124-0349
CR403	1	Zener Diode	Transitron 1N746A	121-0060
CR404,406	2	Zener Diode	Transitron 1N763-1	121-0028
CR405	1	Zener Diode	Motorola 1N3024B	121-0057
Q401,402,403	3	Transistor, NPN	General Electric 2N336A	119-0056
R401	1	Resistor, Fixed, Power, Axial 0.5 ohm, 3 W, 5%	Hardwick Hindle 9/166A-46-0.5	115-0504
R402	1	Resistor, Fixed, Molded 10 ohm, 1/4 W, 10%	IRC GBT 1/4	115-2230
R403	1	Resistor, Fixed, Molded 330 ohm, 2 W, 5%	Allen Bradley HB3305	115-0882
R404	1	Resistor, Fixed, Molded 100 ohm, 1/4 W, 10%	IRC GBT 1/4	115-2231
R405,408,413	3	Resistor, Fixed, Molded 1 K ohm, 1/4 W, 10%	IRC GBT 1/4	115-2238
R406	1	Resistor, Fixed, Precision, M.F. 1.1 K ohm, 1/4 W, 1%	IRC CEA	115-2176
R407	1	Resistor, Fixed, Precision, M.F. 6.04 K ohm, 1/4 W, 1%	IRC CEA	115-2175
R409	1	Resistor, Fixed, Precision, M.F. 3.92 K ohm, 1/4 W, 1%	IRC CEA	115-2179
R410	1	Resistor, Fixed, Precision, M.F. 1.5 K ohm, 1/4 W, 1%	IRC CEA	115-2178
R411	1	Resistor, Fixed, Precision, M.F. 210 ohm, 1/4 W, 1%	IRC CEA	115-2177
R412	1	Resistor, Fixed, Precision, M.F. 10 K ohm, 1/4 W, 1%	IRC CEA	115-2174
R414	1	Resistor, Variable, Trimpot, WW 20 K ohm, 1/2 W	Amphenol Controls Division 2600P-203	115-2267
R415	1	Resistor, Variable, Cermet 1 Megohm, 1/2 W, 10%	Bourns 3009P-1-202	115-2404

NOTE:

REPLACEMENT PARTS MAY BE ORDERED FROM KEPCO, INC. ORDERS SHOULD INCLUDE KEPCO PART NUMBER AND DESCRIPTION.

PLEASE NOTE: THE MANUFACTURER'S NAME AND PART NUMBER LISTED FOR EACH ITEM ON REPLACEMENT PARTS LISTS, REPRESENTS AT LEAST ONE SOURCE FOR THAT ITEM AND IS LISTED SOLELY FOR THE CONVENIENCE OF KEPCO EQUIPMENT OWNERS IN OBTAINING REPLACEMENT PARTS LOCALLY. WE RESERVE THE RIGHT TO USE EQUIVALENT ITEMS FROM ALTERNATE SOURCES.	KEPCO, INC.
------------------------------------------------------------------------------------------------------------------------------------------------------------------------------------------------------------------------------------------------------------------------------------------------------------------------------------	-------------

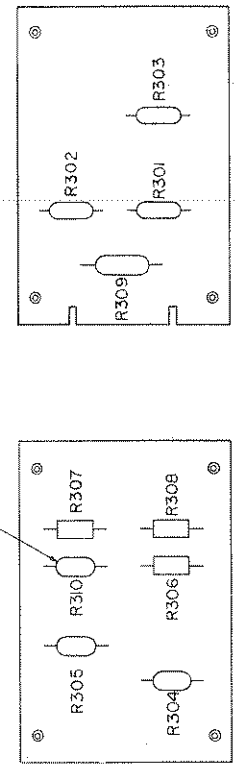
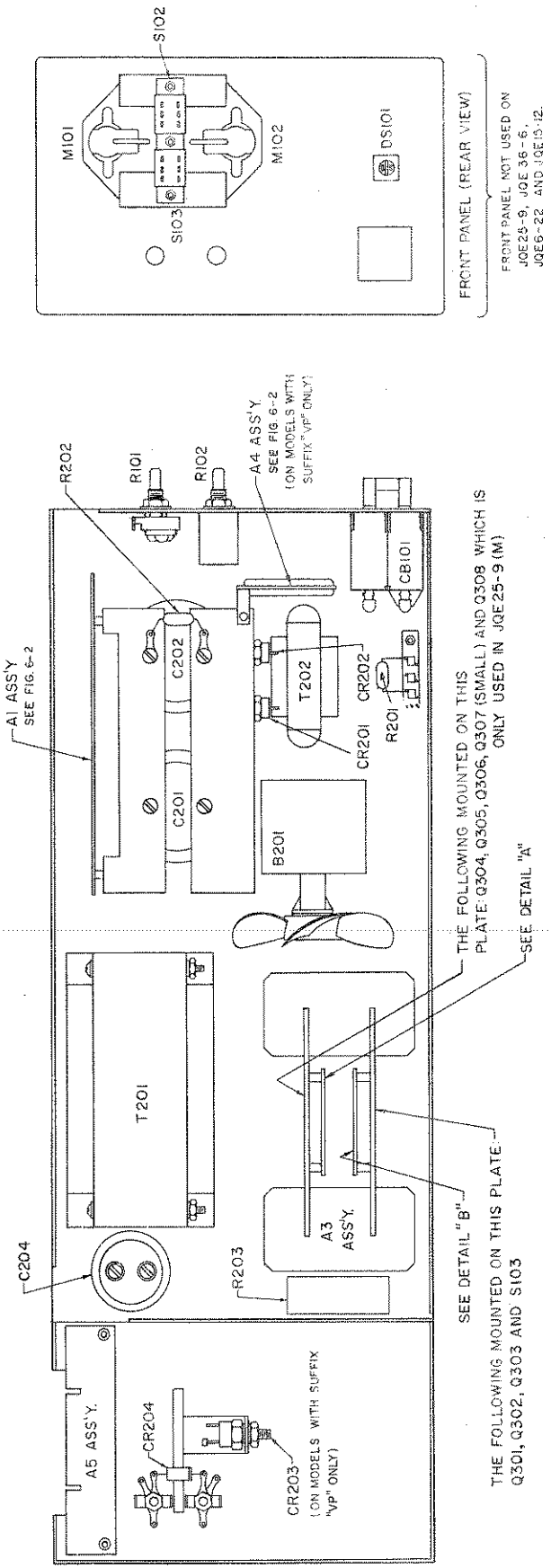
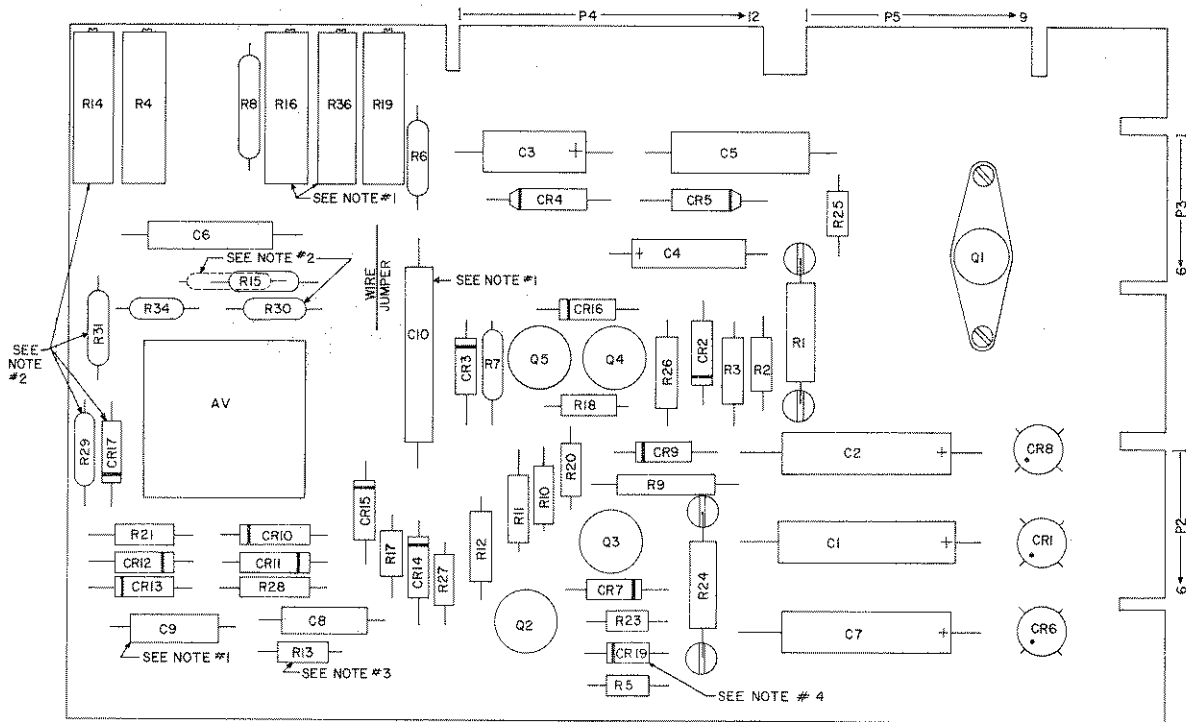
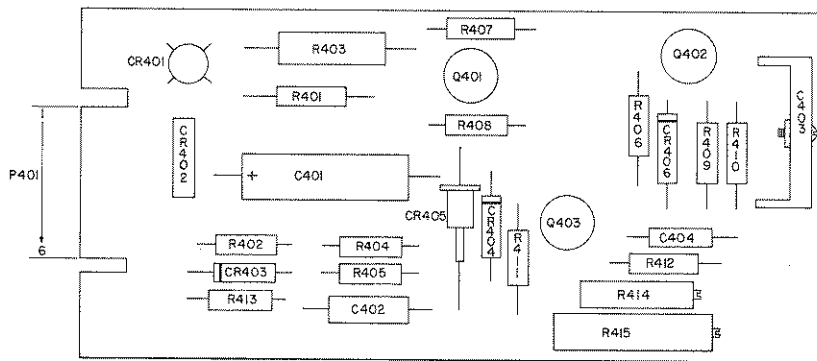

FIG. 6-1 COMPONENT LOCATION, CHASSIS AND AUXILIARY BOARDS



- NOTES:
1. LAG ADJ. I (R36, C10) AND LAG ADJ. II (R16, C9) NOT ON ALL MODELS, SEE MAIN-SCHEMATIC.
 2. ON ALL MODELS WITH SUFFIX "E"
 3. NOT ON MODELS WITH SUFFIX "E"
 4. CR19 IS NOT USED ON ALL MODELS, SEE MAIN SCHEMATIC.

a) AMPLIFIER (A1) ASS'Y



b) VOLTAGE PROTECTOR (A4) ASS'Y

FIG. 6-2 COMPONENT LOCATION, AMPLIFIER AND VP ASSEMBLY

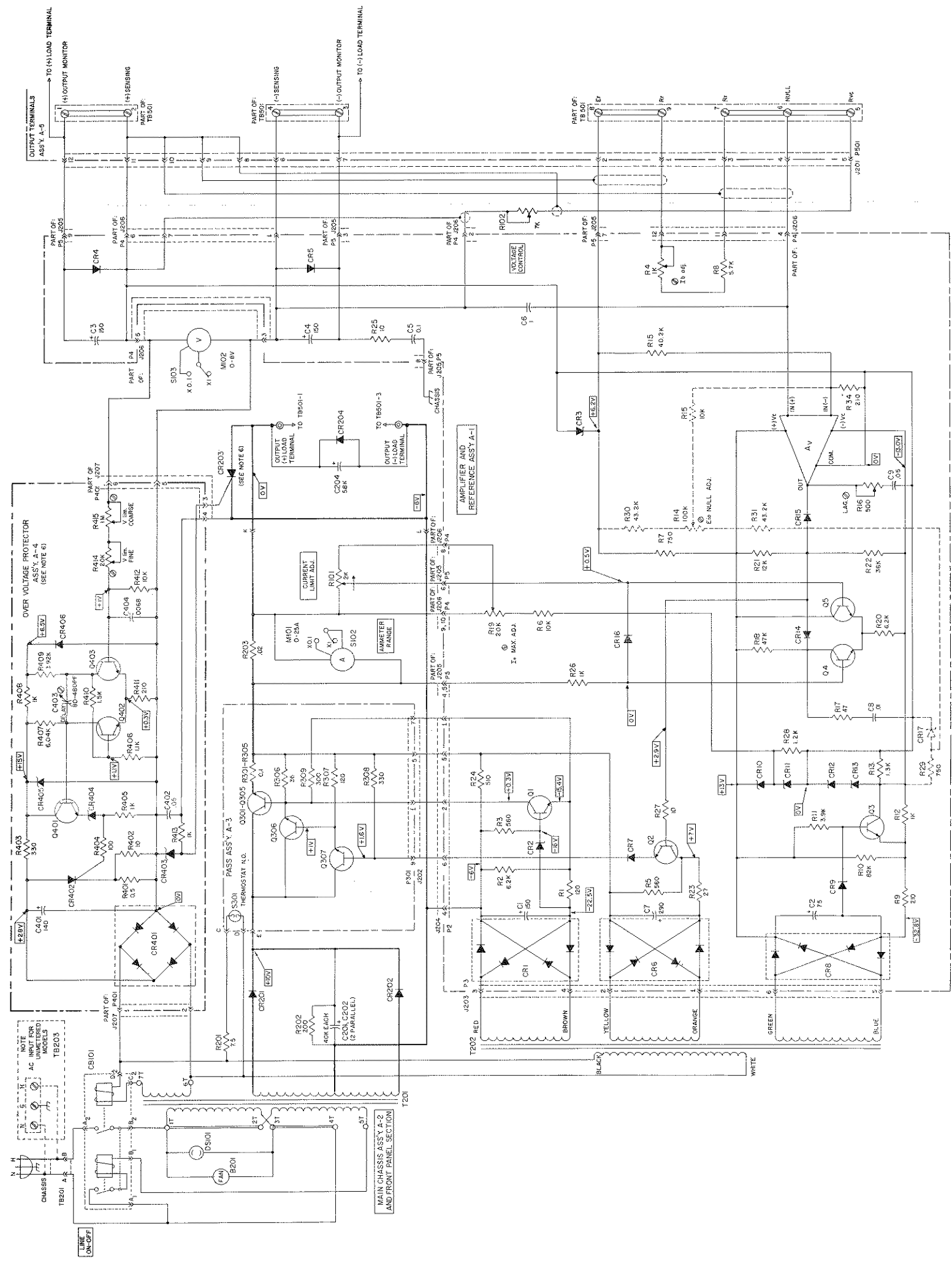

- NOTES:
- RESISTOR VALUES IN OHMS K=1000
 - CAPACITOR VALUES IN MICROFARADS UNLESS OTHERWISE INDICATED.
 - TRANSFORMER TAP POSITIONS, CAPITAL LETTERS ARE "TAP" POSITIONS, NUMERICAL LETTERS ARE "TAP" POSITIONS.
 - VOLTAGE READINGS TAKEN UNDER THE FOLLOWING CONDITIONS:
 - LINE AT 115V AC, 60 HZ, MAX. RATED 100%
 - LOAD AT 100% RATED
 - ALL VALUES WITH REFERENCE TO THE POSITIVE (+) SENSING TERMINAL, EXCEPT IN THE OVERVOLTAGE PROTECTOR CIRCUIT.
 - IN THE OVERVOLTAGE PROTECTOR CIRCUIT, ALL VALUES WITH REFERENCE TO THE POSITIVE (+) SENSING TERMINAL.
 - M101, M102, S102, S103 AND DS101 IN METERS UNITS ONLY
 - THE OVER VOLTAGE PROTECTOR ASSY. A-4 WITH COMPONENT NUMBER 400-499 AND COMPONENT NUMBER CR003 IS OPTIONAL
 - COMPONENTS SHOWN WITH DASHED LINES ARE USED IN MODELS WITH SUFFIX "E" ONLY. R15(1.3K) AND R15(40.2K) ARE DELETED IN THESE MODELS.

Data subject to change without notice.
 PATENT NOTICE: Applicable Patent Numbers will be supplied on request.



FIG. 6-3 MAIN SCHEMATIC, MODEL JOE 6-22 (M)

Please note the following corrections to the Manual Material as indicated:

Parts List and Schematic Diagram:

MAIN SCHEMATIC (FIG. 6-3):

The output capacitor (C204 has been removed from the location indicated on the schematic and has been placed directly across the rear barrier-strip (TB501, terminal (2) and terminal (4) via quick-disconnect connectors.

1. DELETE:	R22	Resistor, Fixed, M.G.	36K ohm, 5%, 1/4W	Kepeco P/N 115-2224.
2. CHANGE:	Q1	Transistor, Silicon, NPN		Kepeco P/N 119-0068
TO:	Q1	Transistor, Silicon, NPN		Kepeco P/N 119-0060.
3. CHANGE:	Q307	Transistor, Silicon, NPN		Kepeco P/N 119-0068
TO:	Q307	Transistor, Silicon, NPN		Kepeco P/N 119-0060.
4. CHANGE:	Q3	Transistor, Silicon, NPN		Kepeco P/N 119-0094
TO:	Q3	Transistor, Silicon, NPN		Kepeco P/N 119-0059.
5. DELETE:	R12	Resistor, Fixed, Molded		Kepeco P/N 115-0340.
6. CHANGE:	Q4,5	Transistor, Silicon, NPN		Kepeco P/N 119-0056
TO:	Q4,5	Transistor, Silicon, NPN		Kepeco P/N 119-0093.
7. ADD:	C10	Capacitor, Ceramic, Disc.	0.005uF, 500V	Kepeco P/N 117-0061.

Note: C10 has been added to Assembly A1. It is connected between the collector and emitter of Q3.

8. CHANGE:	CB101	Circuit Breaker	4 Amp.	Kepeco P/N 127-0272
TO:	CB101	Circuit Breaker	3 Amp.	Kepeco P/N 127-0270.
9. ADD:	C13	Capacitor, Mylar, Axial	0.1uF, 10%, 200V	Kepeco P/N 117-0363.

Note: C13 has been added to Assembly A1. It is connected between the collector and the base of Q1.

10. ADD:	C207	Capacitor, Mylar, Axial	3uF, 10%, 200V	Kepeco P/N 117-0354.
----------	------	-------------------------	----------------	----------------------

Note: C207 has been add to Assembly A2. It is conneced across the main secondary winding of T201.

11. CHANGE:	AV	Plug-In Amplifier		Kepeco P/N 250-0013
TO:	AV	Plug-In Amplifier		Kepeco P/N 250-0052.

Note: The "E" OPTION (E_{10} NULL OR ZERO ADJUST) is now a standard feature on all JOE models.

JQE 6-22(M)/1-670/r3	BMC	JQE 6-22(M)/11-1975/r7	C3416
JQE 6-22(M)/1-1470/r3	C2342	JQE 6-22(M)/1-777/r8	C3668
JQE 6-22(M)/9-1870/r3	BMC	JQE 6-22(M)/5-279/r9	C4326
JQE 6-22(M)/3-1072/r4	C2847	JQE 6-22(M)/1-2580/r10	C4520
JQE 6-22(M)/8-2272/r4	C2937	JQE 6-22(M)/11-3079/r11	C4458
JQE 6-22(M)(VP)/r5	C4462		
JQE 6-22(M)/3-573/r5	C3064		
JQE 6-22(M)/1-2375/r6	C3269		

Please note the following corrections to the Manual Material as indicated:

Parts List and Schematic Diagram:

12. CHANGE:	Q301 thru Q306	Transistor, Silicon, NPN	Kepco #119-0082
	to: Q301 thru Q306	Transistor, Silicon, NPN	Kepco #119-0061.

