



**COMPACT
POWER SUPPLY**

Model JOE 55-2 (M)

Serial No. H.10.6.7.31.

INSTRUCTION MANUAL

The KEPCO equipment described in this instruction manual is of proprietary design, and is licensed under the United States patent rights of Forbro Design Corp.

The contents of this instruction manual are copyrighted. Reproduction of any part may only be made with the specific written permission of KEPCO, Inc. Data subject to change without notice.

©KEPCO, INC. 1968



KEPCO, INC. • 131-38 SANFORD AVENUE • FLUSHING, N.Y. 11352 • (212) 461-7000 • TWX # 710-582-2631 • Telex: 12-6055 • Cable: KEPCOPOWER NEWYORK

TABLE OF CONTENTS

PARAGRAPH		PAGE
SECTION I – INTRODUCTION		
1-1	Scope of Manual	1-1
1-3	General Description	1-1
1-9	Accessories	1-1
1-10	Specifications, General	1-1
1-11	Specifications, Electrical	1-2
1-12	Specifications, Performance	1-3
1-13	Specifications, Physical	1-3
SECTION II – INSTALLATION		
2-1	Unpacking and Inspection	2-1
2-3	Terminations	2-1
2-4	AC Input Requirements	2-2
2-6	Cooling	2-2
2-8	Preliminary Check-Out	2-2
2-10	Installation	2-5/2-6
2-14	Grounding	2-5/2-6
SECTION III – OPERATION		
3-1	Standard Power Supply Operation, Local Control	3-1
3-4	Remote Error Sensing	3-1
3-6	Output Adjustment	3-2
3-8	Introduction to Remote Programming	3-2
3-10	Equations showing the Operation of the Kepco Bridge	3-2
3-12	Adjustments for Exact Programming Ratio	3-3
3-17	General Rules for Remote Programming	3-4
3-19	Output Voltage Programming with External Resistance	3-5
3-21	Programming by Conductance	3-6
3-25	Remote Programming with External Voltage	3-7
3-29	Constant Current Operation	3-8
3-34	Series Operation of two or more JQE Supplies	3-9
3-40	Parallel Operation of two or more JQE Supplies	3-12
SECTION IV – THEORY OF OPERATION		
4-1	Simplified Diagram Discussion	4-1
4-5	Circuit Description	4-2
SECTION V – MAINTENANCE		
5-1	General	5-1
5-3	Disassembly	5-1
5-4	Internal Adjustment Procedures	5-2
5-8	Installation and Adjustment of "Zero" Control	5-2
5-11	Trouble Shooting	5-3
5-16	Power Supply Measurements	5-3
SECTION VI – ELECTRICAL PARTS LIST AND SCHEMATIC		
6-1	General	6-1/6-2
6-3	Ordering Information	6-1/6-2

LIST OF ILLUSTRATIONS

FIGURE		PAGE
1-1	JQE Power Supply, Typical Views (Metered)	-iii-
1-2	JQE Power Supply, Typical Views (Unmetered)	-iv-
1-3	Mechanical Outline Drawing	1-4
2-1	Location of Internal Adjustments	2-1
2-2	Conversion for 230V AC Line Operation	2-2
2-3	Controls and Terminations, JQE Group, Front	2-3
2-4	Rear Terminations, JQE Group	2-4
3-1	Standard Jumper Link Connections	3-1
3-2	Load Connection without Error Sensing	3-1
3-3	Load Connection using Remote Error Sensing	3-1
3-4	KEPCO Power Supply and Comparison Bridge Circuit	3-2
3-5	Connections for Precision Programming Ratio Adjustment	3-4
3-6	Establishing Programming Linearity	3-4
3-7	Remote Resistance Programming	3-5
3-8	Remote Conductance Programming	3-6
3-9	JQE in the Operational Amplifier Mode	3-8
3-10	Constant Current Operating Mode	3-9
3-11	Automatic Series Connection of JQE Power Supplies	3-10
3-12	Master/Slave Series Connection of JQE Power Supplies	3-11
3-13	Automatic Parallel Operation of JQE Power Supplies	3-12
3-14	Automatic Parallel Connection of JQE Power Supplies	3-13
3-15	Master/Slave Parallel Connection of JQE Power Supplies	3-14
4-1	Simplified Diagram, JQE Power Supply	4-1
5-1	Disassembly, JQE Design Group	5-1
5-2	Installation of Zero Control	5-2
5-3	Connections for Power Supply Measurements	5-4
5-4	Main Chassis, Component Location	5-5
5-5	Printed Circuit Board, Component Location	5-6
6-1	Main Schematic	6-11/6-12
6-2	Plug-In Diagram	6-13/6-14
6-3*	Voltage Protector Circuit: Parts List, Schematic and Operating Instructions	6-15/6-16

LIST OF TABLES

TABLE		PAGE
1-1	JQE Group, General Specifications	1-2
1-2	Electrical Specifications	1-2
2-1	Internal Adjustments and Calibrations	2-1
2-2	Controls and Terminations, JQE Group, Front	2-3
2-3	Rear Terminations, JQE Group	2-4

*FIG. 6-3 on Models with suffix “-VP” only.

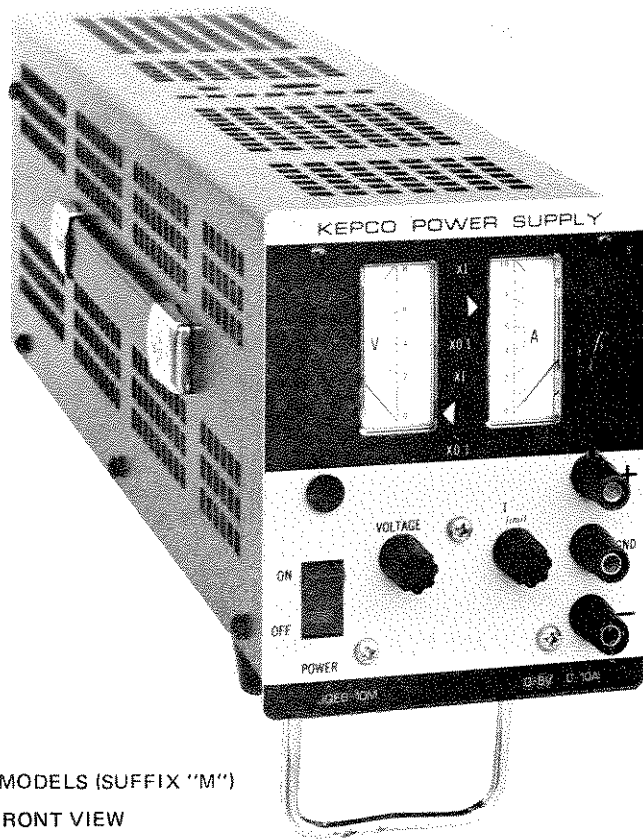

a) METERED MODELS (SUFFIX "M")
TYPICAL FRONT VIEW

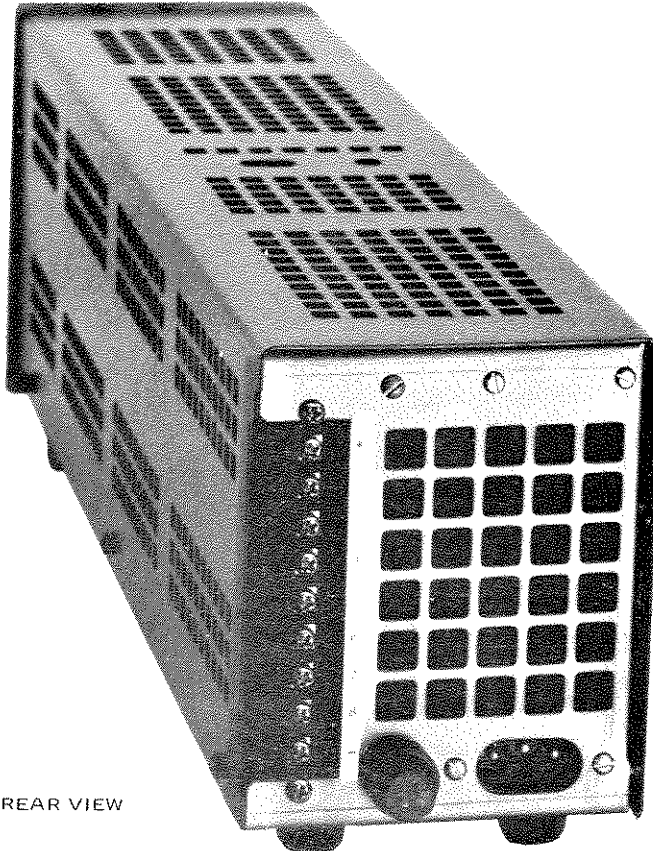

b) TYPICAL REAR VIEW

FIG. 1-1 JQE QUARTER-RACK POWER SUPPLY, TYPICAL (METERED)



a) UNMETERED MODELS
TYPICAL FRONT VIEW

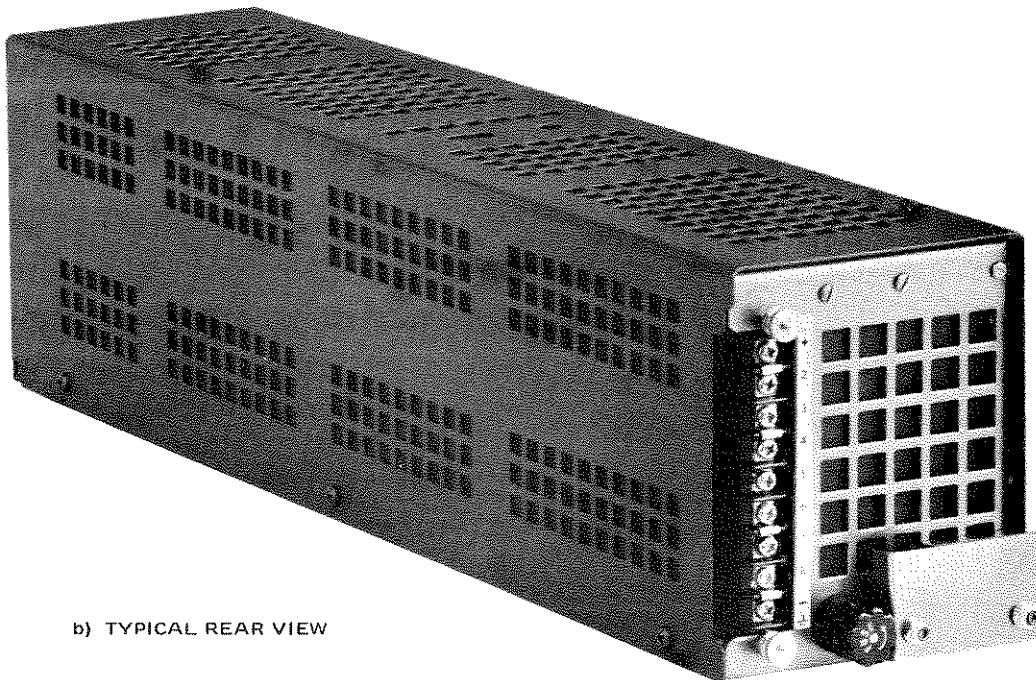

b) TYPICAL REAR VIEW

FIG. 1-2 JQE QUARTER-RACK POWER SUPPLY, TYPICAL (UNMETERED)

SECTION I – INTRODUCTION

1-1 SCOPE OF MANUAL

- 1-2 This manual contains instructions for the installation, operation and maintenance of the Kepco JOE "QUARTER-RACK" Series of Power Supplies.

1-3 GENERAL DESCRIPTION

- 1-4 Kepco Series JOE Power Supplies are general purpose, precision regulated voltage sources in the "quarter-rack" configuration. JOE Power Supplies have linear, full-dissipation series-regulators (NPN) driven by an integrated circuit operational amplifier. A sharp current-limit circuit renders the power supply completely short-circuit proof. JOE Power Supplies may be readily converted to provide constant current by the addition of an external sensing resistor and a "current control". The output of the JOE Power Supply is completely programmable. All necessary connections are available on terminals at the rear barrier-strip.
- 1-5 The compact design of the Kepco JOE "QUARTER-RACK" Series was made possible by a unique heatsink design of exceptional efficiency in combination with highly reliable low-noise fans. JOE power supplies feature all-silicon design with conservatively rated components for added reliability.
- 1-6 JOE Power Supplies are identical in their mechanical dimensions (Refer to FIG. 1-3) and in their electrical specifications, except as noted in TABLE 1-1.
- 1-7 OPTIONS. Optional features of Kepco Power Supplies are indicated by a letter following the model designation:
- JOE Power Supplies with suffix "E" are equipped with an "E_{IO} Null" adjustment, which allows exact zero calibration for precision programming applications.
 - JOE Power Supplies with suffix "HS" are optimized for high speed programming. For these models, a special addendum containing all supplementary specifications is provided in the appendix of the manual. The "E_{IO} Null" ("E") option is automatically included with the "HS" option.
 - JOE Power Supplies with suffix "M" are equipped with two dual range panel meters which permit simultaneous monitoring of the output voltage and output current. Meter range-switches allow for full scale reading of either 10% or 100% of the voltage and current outputs.
 - JOE Power Supplies with suffix "T" have special references which improve the temperature coefficient of the supply (see paragraph 1-11 for specification).
 - JOE Power Supplies with suffix "VP" are equipped with an overvoltage protector. This electrical "crowbar" shorts the output through a silicon controlled rectifier (SCR) if the output voltage exceeds a preadjustable limit on the protector (see paragraph 1-12 for specifications).
- 1-8 The main chassis frame of the power supply is constructed from cold-rolled steel, as is the perforated wrap-around cover. Front panel material is aluminum (Refer to FIG. 1-3 for finish).

1-9 ACCESSORIES

- a) RACK ADAPTER (FOR FOUR UNITS): KEPKO MODEL RA24. Fits standard EIA rack dimensions. FILLER PANELS to cover empty slots if adapter is used for less than its capacity:
- KEPCO MODEL RFP 24-1, to cover one (1) empty slot.
 - KEPCO MODEL RFP 24-2, to cover two (2) empty slots.
 - KEPCO MODEL RFP 24-3, to cover three (3) empty slots.

1-10 SPECIFICATIONS, GENERAL

- a) AC INPUT: 105 to 125V AC or 210 to 250V AC (selectable, refer to SECTION II), 50 to 65 Hz,* single phase. Refer to the table of general specifications (TABLE 1-1) for the AC input current for each model.
- b) OPERATING TEMPERATURE RANGE: (-)20°C to (+)71°C (without derating of the output).

*Consult factory for operation on power line frequencies above 65 Hz.

- c) STORAGE TEMPERATURE: -50°C to $(+85^{\circ}\text{C})$.
- d) COOLING: High efficiency, single bearing fan, (permanently lubricated) with special low noise non-metal blade.
- e) ISOLATION: A maximum of 500 volts (DC or p-p) can be connected between chassis and either output terminal.
- f) OUTPUT IMPEDANCE: TABLE 1-1.

MODEL	DC OUTPUT RANGE		OUTPUT IMPEDANCE (OHMS + μH)			MAX. INPUT CURRENT Amps @ 125V AC
	VOLTS	AMPS	DC—100 Hz	0.1—1 kHz	1 kHz—100 kHz	
JQE 6—10M	0—6	0—10	$30\ \mu\Omega$	0.01	$0.02 + 1$	2.3
JQE 15—6M	0—15	0—6	$125\ \mu\Omega$	0.01	$0.02 + 1$	2.3
JQE 25—4M	0—25	0—4	$300\ \mu\Omega$	0.01	$0.02 + 1$	2.3
JQE 36—3M	0—36	0—3	$600\ \mu\Omega$	0.01	$0.02 + 1$	2.3
JQE 55—2M	0—55	0—2	$1.4\ \text{m}\Omega$	0.01	$0.02 + 1$	2.3
JQE 75—1.5M	0—75	0—1.5	$2.5\ \text{m}\Omega$	0.01	$0.02 + 1$	2.3
JQE 100—1M	0—100	0—1	$5\ \text{m}\Omega$	0.01	$0.02 + 1$	2.3

TABLE 1-1 JQE GROUP, GENERAL SPECIFICATIONS

1-11 SPECIFICATIONS, ELECTRICAL

- a) Refer to TABLE 1-2.
- b) VOLTAGE RECOVERY TIME: (for step load current), $< 50\ \mu\text{sec}$.
- c) OVERSHOOT: No output voltage overshoot from turn-on, turn-off, or power failure for output settings above 25% of maximum rated output voltage. Below 25%, output voltage overshoot is a function of load current and is negligible for loads in excess of 10% of the maximum rated load current.

PARAMETER	VOLTAGE MODE	CURRENT MODE (external sensing)
OUTPUT RANGE (Minimum)	0 to 100% E_0 max.	1 mA to 100% I_0 max.
REGULATION, LINE (105 to 125V or 210 to 230V AC)	$< 0.0005\%$ of E_0 max.	$< 0.005\%$ of I_0 max.***
REGULATION, LOAD (FROM "NO LOAD" TO "FULL LOAD")	$< 0.005\%$ of E_0 max. or $0.2\ \text{mV}^*$	$< 0.01\%$ of I_0 max.***
STABILITY: (8 Hr. TIME PERIOD AT CONSTANT LOAD-LINE — TEMPERATURE)	$< 0.01\%$ of E_0 max. or $1\ \text{mV}^*$	$< 0.02\%$ of I_0 max.***
TEMPERATURE COEFFICIENT per $^{\circ}\text{C}^{**}$	$< 0.01\%$ of E_0 max.	$< 0.02\%$ of I_0 max.***
RIPPLE: rms, (MAXIMUM UNDER ANY OPERATING CONDITION)	$< 0.2\ \text{mV}$	$< 0.02\%$ of I_0 max.

*NOTE: whichever is greater.

**NOTE: Models with suffix "T" have Temperature Coefficients of 0.005% per $^{\circ}\text{C}$ (Voltage Mode) and 0.01% per $^{\circ}\text{C}$ (Current Mode).

***NOTE: Current Regulation, Stability, and Temperature Coefficient is measured across the external sensing resistor. This resistor must be a high quality, wire-wound unit, with a wattage at least 10 times the actual power dissipated, have a Temperature Coefficient of at least 20 parts per million, and produce a voltage sample of 1 volt (for $I_0 > 5\text{A}$) at the maximum rated output current.

TABLE 1-2 JQE 1/4-RACK ELECTRICAL SPECIFICATIONS

1-12 SPECIFICATIONS, PERFORMANCE

- a) VOLTAGE CONTROL*: 10 turn precision rheostat at the front panel, resolution: 0.05% of E_O max. Controls the output voltage from zero to E_O max.
- b) CURRENT LIMIT CONTROL*: 10 turn vernier control at the front panel permits adjustment of the current limit from 10% to 105% of maximum rated output current (I_O).
- c) REMOTE ERROR SENSING: Rear barrier-strip terminals provide for connection of the error sensing leads directly at the load, thus compensating for losses due to load current voltage drops. Up to 0.5V per output lead can be compensated.
- d) REMOTE PROGRAMMING: Rear barrier terminals provide for remote control of the power supply by resistance (control loop uses 1 mA with a Programming Ratio of 1000 ohms per volt), or by external control voltage.
- e) SERIES/PARALLEL: Series operation of JQE Power Supplies is possible up to the rated isolation voltage. Parallel operation using "Automatic Parallel" or "Slave-Master" parallel connections may be performed.
- f) OVERVOLTAGE PROTECTOR (MODELS WITH SUFFIX "VP")
 - 1) RANGE: 3V DC – 110V DC (adjustable).
 - 2) TRIGGERING TIME: 5 to 10 microseconds, adjustable by means of a delay-control.
 - 3) THRESHOLD: Overvoltage device may be set to within 5% or 0.25 volts of the power supply's output voltage (whichever is greater).

*Knob controlled on all metered models (suffix "M"), locking type screw-driver controls on un-metered models.

1-13 SPECIFICATIONS, PHYSICAL (Refer to FIG. 1-3 MECHANICAL OUTLINE DRAWING).

- a) DIMENSIONS: (cased unit) Refer to Mechanical Outline Drawing (FIG. 1-3).
- b) TERMINATIONS: Refer to Mechanical Outline Drawing (FIG. 1-3) and Section II of this Manual.
- c) FINISH:
 - 1) CHASSIS: cadmium plated, cronak wash.
 - 2) PANEL (on models with suffix "M" only): Light gray, Color #26440, Federal Standard 595.
 - 3) CASE: Charcoal gray texture.
- d) METERS (on model with suffix "M" only): Two dual range (100% and 10% of E_O max. and I_O max.), 2 inch tautband, recessed panel meters accuracy 3% of full scale reading, for output voltage and output current monitoring.
- e) MOUNTING: Rack adaptor available, see "Accessories" (paragraph 1-3). A retractable "bail" is provided to adjust the supply to a convenient viewing and operating angle on the bench. (Models with suffix "M" only).

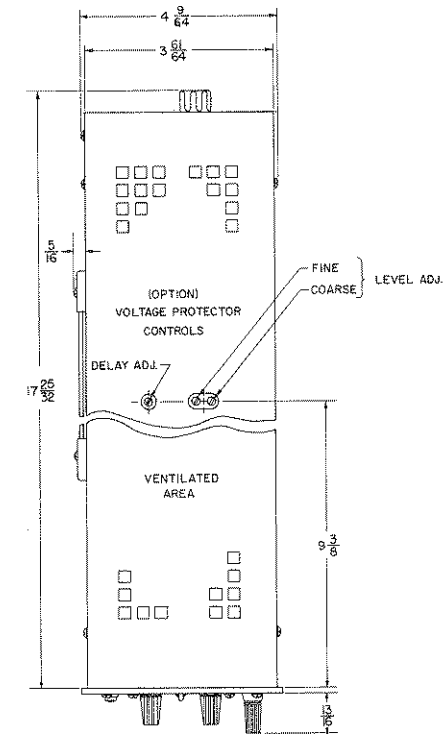

REAR OUTPUT TERMINAL FUNCTIONS

1. (+) OUTPUT
2. (+) SENSING
3. (+) 6.2V NOM. REFERENCE VOLTAGE
4. } REFERENCE RESISTOR NETWORK
5. }
6. NULL JUNCTION (AMPLIFIER INPUT INVERTED) } NORMALLY LINKED
7. VOLTAGE CONTROL RESISTANCE
8. (-) SENSING
9. (-) OUTPUT

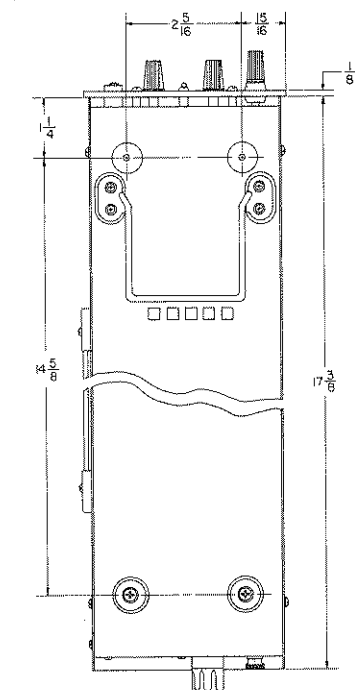
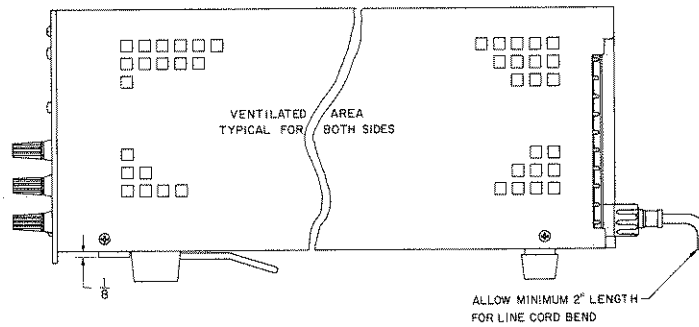
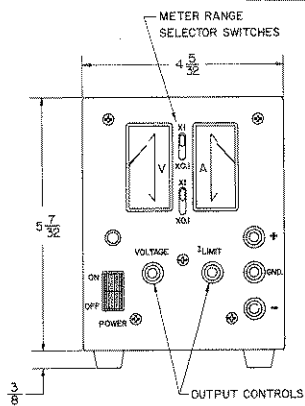
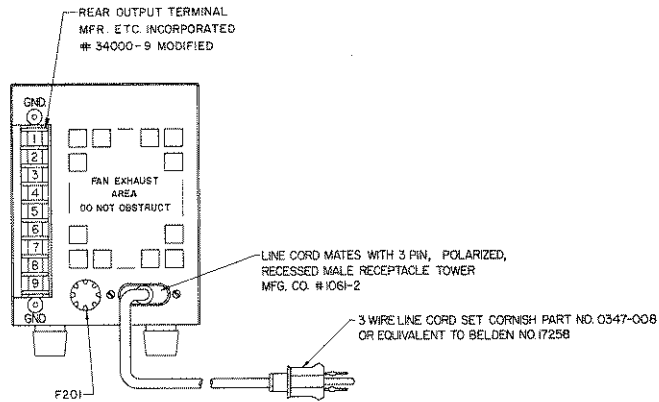

NOTES:

1. THIS DRAWING IS USED FOR THE FOLLOWINGS MODELS:
 JQE 6-10M, JQE 15-6M, JQE 25-4M,
 JQE 36-3M, JQE 55-2M, JQE 75-1.5M
 AND JQE 100-1M
2. MATERIAL: A) COVER: #20 GAUGE C.R.S.
 B) FRONT PANEL: 1/8 THICK ALUMINUM...
 C) CHASSIS: #16 GAUGE C.R.S.
3. FINISH: A) COVER: CHARCOAL GRAY, VINYL TEXTURE.
 B) FRONT PANEL: LIGHT GRAY PER FEDERAL STD. 595,
 COLOR # 26440
 C) CHASSIS: CADMIUM PLATE WITH CRONAK WASH.
4. RACK MOUNTING: REMOVE HANDLE, (2) REAR FEET AND FRONT BAIL.

FIG. 1-2 MECHANICAL OUTLINE

SECTION II – INSTALLATION

2-1 UNPACKING AND INSPECTION

2-2 This instrument has been thoroughly inspected and tested prior to packing and is ready for operation. After careful unpacking, inspect for shipping damage before attempting to operate. Perform the preliminary operational check as outlined in paragraph 2-11 below. If any indication of damage is found, file an immediate claim with the responsible transport service.

2-3 TERMINATIONS

- a) FRONT PANEL: Refer to FIG. 2-2 and TABLE 2-2.
- b) REAR: Refer to FIG. 2-3 and TABLE 2-3.
- c) INTERNAL ADJUSTMENTS AND CALIBRATIONS: Refer to FIG. 2-1 and TABLE 2-1.

REFERENCE DESIGNATION	CONTROL	PURPOSE	ADJUSTMENT PROCEDURE
C403	Delay adjust*	Adjust Delay Time of VP.	
R19	I_o max. adjust	Current Limit Control Cal.	par. 5-6
R4	I_b adjust	Control Current Calibration	par. 3-16
R16	Lag Adjust (Not used on all models)	AC Stability Adjustment	par. 5-7
R14	E_{i0} null adjust*	Output Voltage Precision Zero	par. 3-16
R412	Overvoltage Level adjust* (FINE)	Adjusts Protector Threshold	FIG. 6-3
R413	Overvoltage Level adjust* (COARSE)	Adjusts Protector Threshold	FIG. 6-3

*NOTE: Optional controls, see par. 1-7

TABLE 2-1 INTERNAL ADJUSTMENTS AND CALIBRATIONS

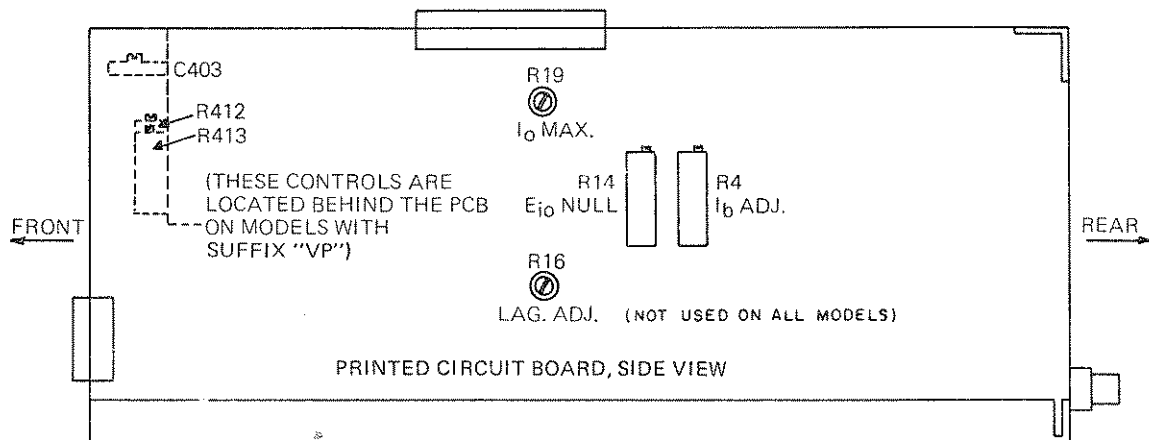

FIG. 2-1 LOCATION OF INTERNAL ADJUSTMENTS

2-4 AC INPUT REQUIREMENTS

- 2-5 This power supply is normally supplied for operation on a single phase, nominal 115V AC line. For conversion to 230V AC line operation, refer to FIG. 2-2. Remove the two wire jumpers between transformer terminals (1)–(2)–(3) and (4)–(5). Re-connect one (1) jumper between terminals (3) and (4). Do not change any other wiring on the transformer. Change main fuse value (F201) to 1/2 its former rating.

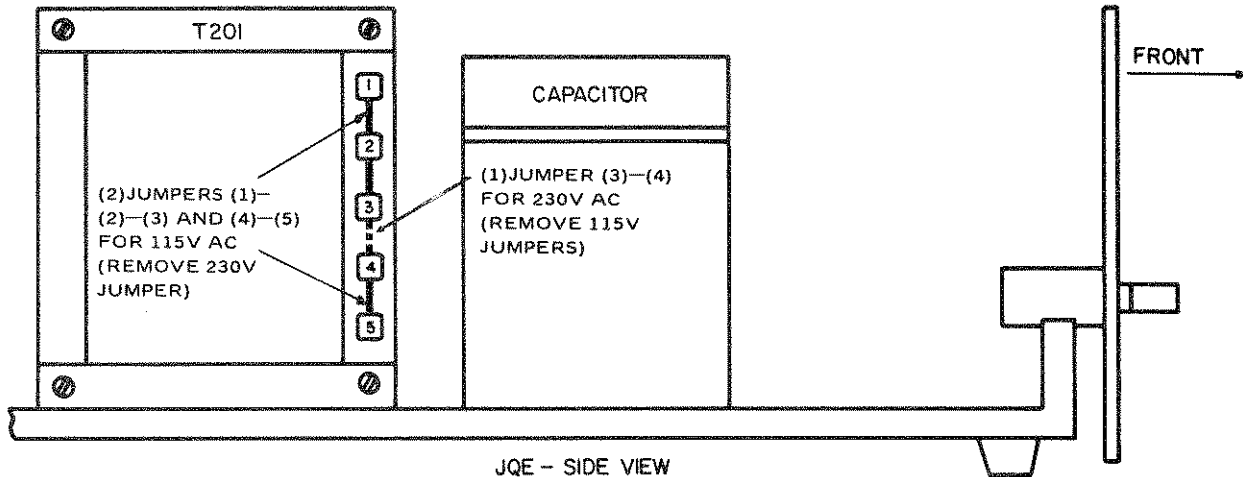

FIG. 2-2 CONVERSION FOR 230V AC NOMINAL LINE

2-6 COOLING

- 2-7 The power transistors and rectifiers in this power supply are maintained within their operating temperature range by means of a high efficiency heat-sink assembly, cooled by an internal fan. SIDE PANEL OPENINGS AND THE TOP OF THE CASE MUST BE KEPT CLEAR FROM OBSTRUCTIONS TO INSURE PROPER AIR CIRCULATION. Periodic cleaning of the interior of the power supply is recommended. If the power supply is rack mounted, or installed into confined spaces, care must be taken that the ambient temperature does not rise above the limit specified (Refer to Section I).

2-8 PRELIMINARY CHECK-OUT

- 2-9 A simple operating check after unpacking and before permanent installation is advisable, to ascertain whether the power supply has suffered damage resulting from shipment. Please refer to FIG. 2-3 for the location of the operating controls and output terminals.
- Connect power supply to 115V AC line or refer to paragraph 2-6 for 230V AC operation if required.
 - Turn CURRENT LIMIT CONTROL fully clockwise. Turn VOLTAGE CONTROL fully counterclockwise. Both, VOLTMETER RANGE* and AMMETER RANGE* switch should be in the "x1" position.
 - Turn AC POWER SWITCH* "on." The AC PILOT LIGHT* should be energized. Slowly turn VOLTAGE CONTROL clockwise and observe the gradual increase of the output voltage. Turn counterclockwise again until about one-tenth of the maximum output voltage is reached. Set VOLTMETER RANGE* switch to the "x0.1" position. The VOLTMETER* should now read full scale again. Return both, AMMETER and VOLTMETER RANGE SWITCHES* to the "x1" position.
 - (Models suffixed, "–VP" only). Check the "crowbar" action of the overvoltage protector by first adjusting the VOLTAGE CONTROL to about 1/4 of its range. Locate the "OVERVOLTAGE LEVEL" adjustments (R412,413 refer to FIG. 2-1) and turn the "Coarse" adjustment (R413) slowly counterclockwise until the output voltage goes suddenly to zero as observed on the panel meter. Turn AC POWER SWITCH* "off." Turn the "OVERVOLTAGE LEVEL" control (R413) fully clockwise again.

*On models with suffix "M" only, connect appropriate external metering and AC input switching to meterless models.

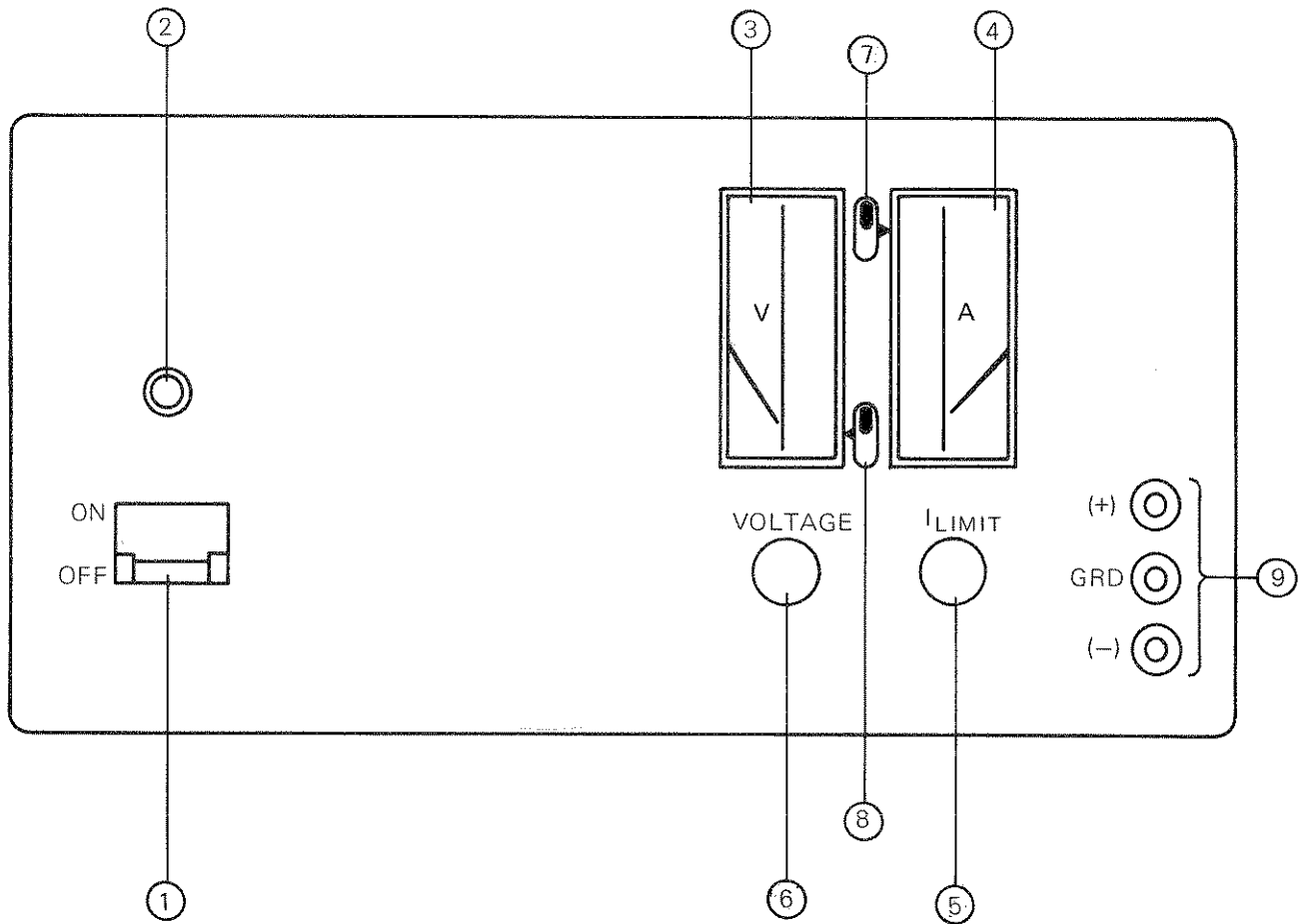

FIG. 2-3 FRONT PANEL CONTROLS AND TERMINATIONS, HALF-RACK JOE MODELS

NO.	CONTROL OR TERMINATION	FUNCTION
1	AC POWER SWITCH/ CIRCUIT BREAKER	TURNS AC POWER LINE, "ON" OR "OFF" AND PROTECTS POWER SUPPLY INPUT CIRCUITRY
2	AC PILOT LIGHT	ENERGIZES WHEN AC POWER IS "ON"
3	VOLTMETER	MONITORS OUTPUT VOLTAGE, 0- E_o max.
4	AMMETER	MONITORS OUTPUT CURRENT 0- I_o max.
5	CURRENT LIMIT CONTROL	ADJUSTS CURRENT LIMIT FROM 0-105% I_o max.
6	VOLTAGE CONTROL	ADJUSTS OUTPUT VOLTAGE FROM ZERO TO E_o max.
7	METER RANGE SWITCH, AMPERE	MAY BE SET TO FULL SCALE READING OF MAXIMUM OR 1/10 OUTPUT
8	METER RANGE SWITCH, VOLTS	MAY BE SET TO FULL SCALE READING OF MAXIMUM OR 1/10 OUTPUT
9	FRONT OUTPUT TERMINALS	FOR LOAD CONNECTION (ON MODELS WITH 15A DC OUTPUT AND LOWER ONLY)

TABLE 2-2 CONTROLS AND TERMINATIONS, HALF-RACK JOE MODELS, FRONT

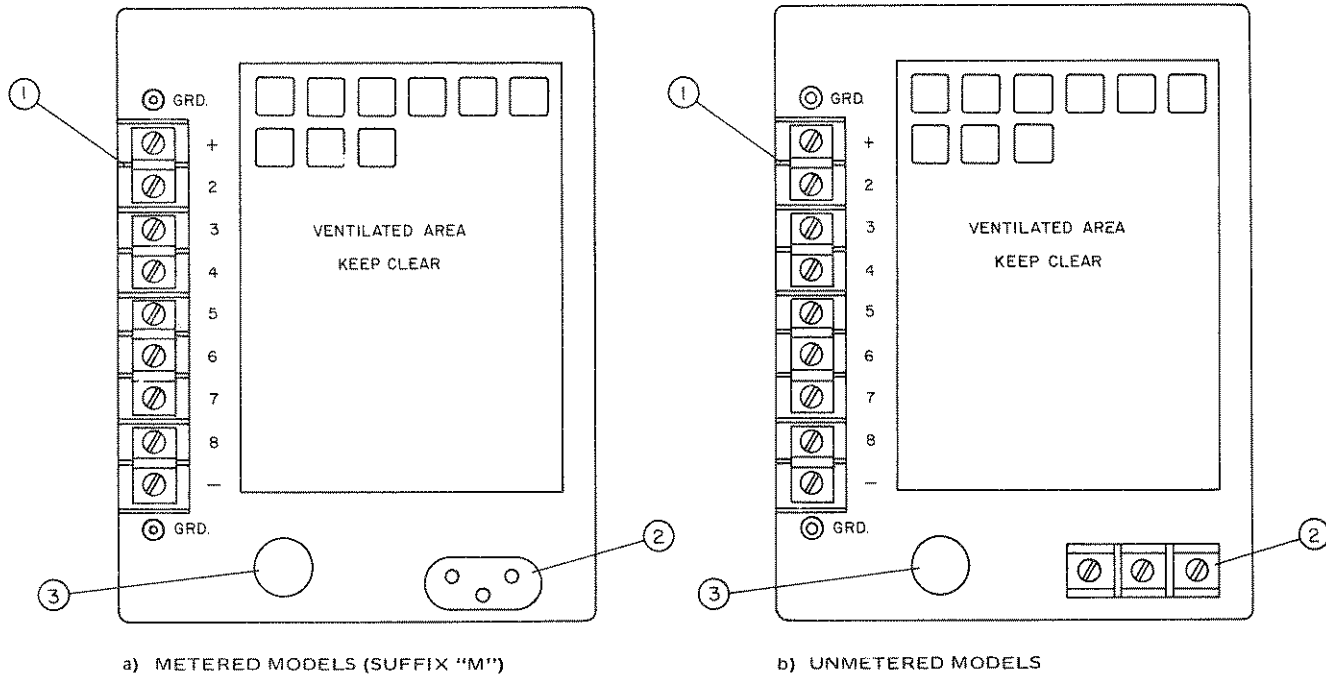

FIG. 2-4 REAR TERMINATIONS, JOE ¼ RACK GROUP, REAR

NO.	TERMINATION	FUNCTION
1	REAR BARRIER-STRIP, WITH THESE TERMINAL FUNCTIONS:	1 POSITIVE (+) LOAD TERMINAL 2 POSITIVE (+) ERROR SENSING TERMINAL (COMMON) 3 REFERENCE VOLTAGE (E_r) (+6.2 nom.) 4 REFERENCE RESISTOR (R_r) 5 6 NULL JUNCTION 7 VOLTAGE CONTROL (R_{vc}) 8 NEGATIVE (-) ERROR SENSING 9 NEGATIVE (-) LOAD TERMINAL
2	AC INPUT	a) ACCEPTS THREE WIRE AC POWER LINE CORD (SUPPLIED) b) 3-TERMINAL BARRIER-STRIP FOR AC LINE WIRING
3	MAIN FUSE (F201)	PROTECTS MAIN TRANSFORMER AND INPUT CIRCUIT

TABLE 2-3 REAR TERMINATIONS, JOE ¼ RACK GROUP, REAR

- e) Place a short circuit across the output. Turn CURRENT LIMIT CONTROL counterclockwise. Turn AC POWER SWITCH* "on". Slowly turn CURRENT LIMIT CONTROL clockwise and observe the gradual increase in output current. Turn counterclockwise until about one tenth of the maximum output current is reached. Set AMMETER RANGE* switch to the "x0.1" position. The AMMETER* should now read full scale again.



Do not switch to the "x0.1" ranges before the output of the power supply (voltage or current) is below 10% of the maximum rated values.

*On models with suffix "M" only. Connect appropriate external metering and AC input switch to meterless models.

2-10 INSTALLATION (Refer to FIG. 1-3 "Mechanical Outline Drawing")

- 2-11 The metered JOE Power Supply (Models with suffix "M") may be used as a bench-operated instrument. For these units, a retractable "bail" is provided to lift the power supply front to a convenient viewing and operating angle. If the metered JOE supply is to be rack-mounted, the bail, the two rear feet and the side handles must be removed.
- 2-12 The unmetered JOE Power Supply can be directly chassis-mounted into any system. Four nylon mounting stand-offs are provided at the bottom of the unit. If no additional mechanical support is provided, the unit must always be mounted so that its weight rests on the four mounting stand-offs.
- 2-13 For all installations into confined spaces, care must be taken that the temperature immediately surrounding the unit does not exceed the maximum specified ambient temperature (71°C).

2-14 GROUNDING

- a) AC GROUND (Models with suffix "M" only). The power supply is equipped with a 3 wire safety line cord and polarized plug. The third (green) wire in the line cord is connected to the chassis and the case of the unit. If a two terminal receptacle in combination with an adaptor is used, it is imperative that the chassis of the power supply be returned to AC ground with a separate lead.
- b) AC GROUND (Unmetered Models). The power supply is equipped with a three terminal barrier-strip for AC input. The terminal marked "GRD" is directly connected to the power supply chassis and must be returned to AC ground.
- c) DC GROUND. The DC output is isolated from the AC power line and from any direct connection to chassis or ground. The maximum output voltage that can be supported between either output terminal and ground or chassis is 500V DC plus the maximum output voltage of the power supply. Either side of the output may be grounded. Convenient grounding terminals are provided at the front panel binding post (on models with suffix "M") and at the rear barrier-strip.

SECTION III – OPERATION

3-1 STANDARD POWER SUPPLY OPERATION, LOCAL CONTROL

3-2 GENERAL. The JOE Power Supply is shipped from the factory with five (5) removable jumper links in place at the rear barrier strip (TB1) as shown in FIG. 3-1. THESE LINKS MUST BE IN PLACE AND SECURED THIGHTLY for standard local operation. Loose terminal links or wires at the barrier strip will cause malfunction of the power supply.

3-3 LOAD CONNECTION. The load may be connected in any of the four ways illustrated in FIG.'s 3-2/3-3. Load connecting wires should be as heavy as practicable, since load wire voltage drops will degrade regulation performance. Twisting of load wires will help to preserve the low output impedance of the JOE power supply.

3-4 REMOTE ERROR SENSING

3-5 Specified regulation performance directly at the load requires the use of remote error sensing. A twisted, shielded pair of wires from the sensing terminals directly to the load will compensate for load wire voltage drops up to 0.5 volt per wire (Refer to FIG. 3-3). Observe polarities: The negative sensing wire [from terminal (8)] must go to the negative load wire, and the positive sensing wire [from terminal (2)] goes to the positive load wire.



**FIG. 3-1
STANDARD JUMPER-
LINK CONNECTIONS
JOE GROUP**

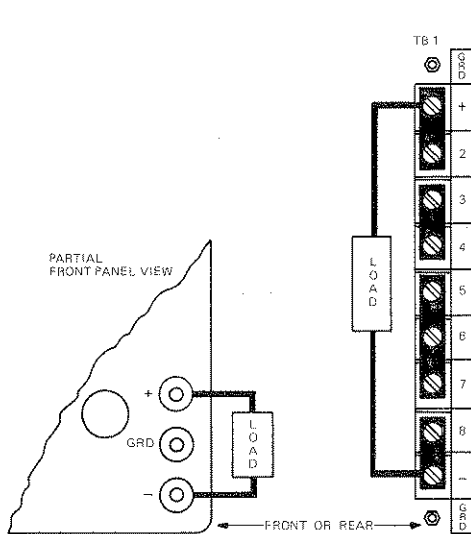

**FIG. 3-2 LOAD CONNECTION WITHOUT
ERROR SENSING**

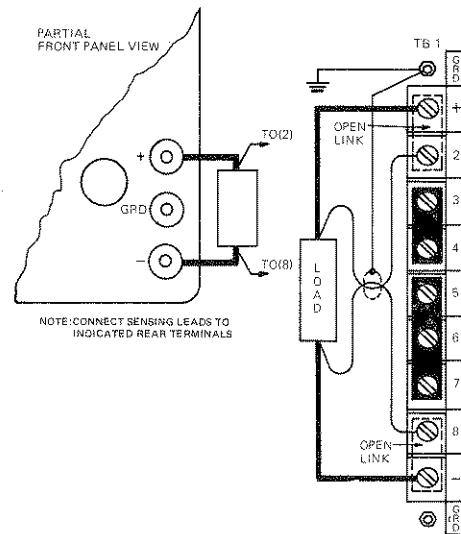

**FIG. 3-3 LOAD CONNECTION USING REMOTE
ERROR SENSING**

- NOTE: 1)** If Error Sensing is not used, Specified Performance must be measured at terminals (2) and (8) of TB1.
- 2)** Front panel load connections applicable for models with suffix "M" only.

3-6 OUTPUT ADJUSTMENT*

3-7 Once the load is connected to the output terminals of the power supply as described in the previous paragraphs, the operating voltage may be adjusted to the desired value by turning the VOLTAGE CONTROL and observing the panel VOLTMETER.** The CURRENT LIMIT CONTROL may be set fully clockwise, and will in this position provide over current protection at 105% of the maximum rated output current. The CURRENT LIMIT CONTROL may be set to intermediate values, as desired, by first turning the AC POWER SWITCH** to the "off" position and then placing a short circuit across the output. Now the required operating current is adjusted by turning the CURRENT LIMIT CONTROL to the value needed plus $\approx 2\%$. The output current will now limit sharply at this value. After the short is removed from the output, the load is reconnected and the power supply is ready for operation.

3-8 INTRODUCTION TO REMOTE PROGRAMMING

3-9 GENERAL. A few general remarks may be in order to familiarize the user of this equipment with the terminology and basic equations pertaining to remote programming of the Kepco JQE Power Supplies. Electrically, the power supply consists of the unregulated DC source (E_U), the pass element (E_P), the DC error amplifier (A) and a comparison circuit which resembles a four-arm electrical bridge. (Refer to FIG. 3-4). The elements of the bridge are arranged to produce a virtual zero at the amplifier input when the bridge circuit is at balance ($V_{AA'} = 0$). Any tendency for the output voltage to change in relation to the reference voltage (E_r) creates an error signal (e) which, by means of negative feedback and the amplifier, tends to correct the output voltage towards restoration of bridge balance.

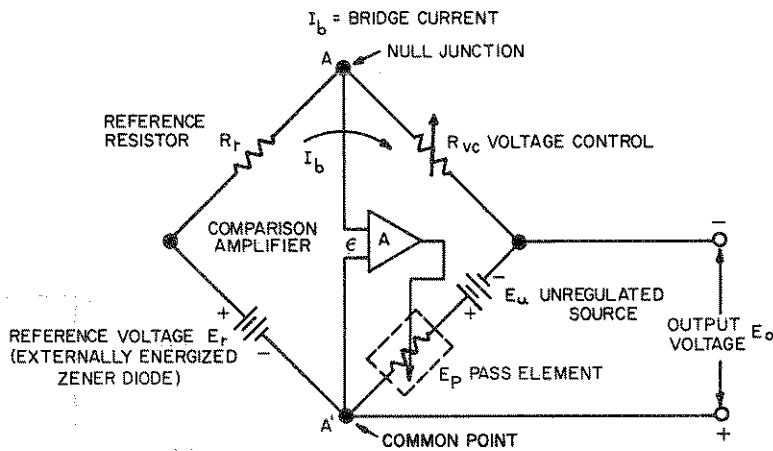

FIG. 3-4 KEPKO POWER SUPPLY AND COMPARISON BRIDGE CIRCUIT

3-10 EQUATIONS SHOWING THE OPERATION OF THE KEPKO BRIDGE

3-11 The following relationships govern the operation of the Kepco Bridge at balance, i.e., with $V_{AA'} = 0$:

$$a) \quad \frac{E_o}{E_r} = \frac{R_{vc}}{R_r}$$

Where: E_o = Output Voltage
 E_r = Reference Voltage
 R_r = Reference Resistance
 R_{vc} = Control Resistance
 I_b = Bridge Current

$$\frac{E_r}{R_r} = I_b \quad (2)$$

$$E_o = I_b R_{vc} \quad (3)$$

b) The ratio of the number of ohms control-resistance needed per volt output is termed the "CONTROL RATIO". It is nominally 1000 ohms per volt in the JQE Power Supplies.

*NOTE: (Models with suffix "-VP" only) Refer to FIG. 6-3 for the operating instructions on the OVERVOLTAGE PROTECTOR.

**On models with suffix "M" only. Connect appropriate external metering and AC input switching to meterless models.

- c) As can be seen from equation (1), the output voltage E_O can be controlled by varying any one of the three quantities. Rewriting equation (1) we have:

$$E_O = \frac{E_r}{R_r} \times R_{VC}$$

The ratio $\frac{E_r}{R_r}$ constitutes the bridge current I_b . (Eq.2).

- d) Therefore, we can write: $E_O = I_b R_{VC}$ (Eq.3).
Making I_b a precision quantity (precision bridge current adjustment is described in par. 3-16), establishes a precise programming ratio, so that the accuracy of E_O is solely dependent upon R_{VC} . This mode of operation is referred to as "RESISTANCE PROGRAMMING" and is covered in detail in Par, 3-19.
- e) Rewriting Equation (1), $E_O = E_r \frac{R_{VC}}{R_r}$, we can make E_r the variable which controls E_O .
This type of control is referred to as "VOLTAGE PROGRAMMING" and is covered in Par. 3-5.
- f) Many other modes of control are of course possible; some of them are described in the following paragraphs. For a more extensive treatment and a detailed theoretical view of power supply applications, see the "Kepco Power Supply Handbook", available from your Kepco Representative or directly from Kepco Applications Engineering Department.

NOTE: For all programming and adjustment components, use high quality, wire-wound, resistors with a T.C. of 20 p.p.m. or better.

3-12 ADJUSTMENTS FOR EXACT PROGRAMMING RATIO

- 3-13 Referring to equation (3): $E_O = I_b R_{VC}$, it is seen that if $I_b = 1$ mA, 1000 ohms of control resistance (R_{VC}) is needed for each volt of output. Once I_b is therefore adjusted precisely, the accuracy and linearity of the output voltage will then solely depend upon R_{VC} .
- 3-14 Again referring to equation (3), we see that if $R_{VC} = 0$ (shorted out), the output voltage should be zero. A small negative offset voltage (in the millivolt range) exists however under this condition at the output.
- 3-15 Both inaccuracies, the slightly larger bridge current (I_b) and the small negative offset voltage may be adjusted to provide a linear and precise programming ratio. While the " I_b Adj." control (R4) is a standard feature in all models, the " E_{IO} null" (R14) or offset zeroing control is provided only in models bearing the suffix "E" (Model JQE 6-10ME for example). This control can however be added by the user (see paragraph 5-8).

3-16 PROCEDURE, PRECISION PROGRAMMING RATIO ADJUSTMENT (Refer to FIG. 3-5)

- a) Equipment Required:
- 1) Precision digital or differential voltmeter (M1).
 - 2) Precision resistor, accuracy comparable to M1. The value is not important, but must be known. For every 1000 ohms 1 volt will appear across M1. (R_{VC}).
 - 3) Single pole, single throw switch (S1).

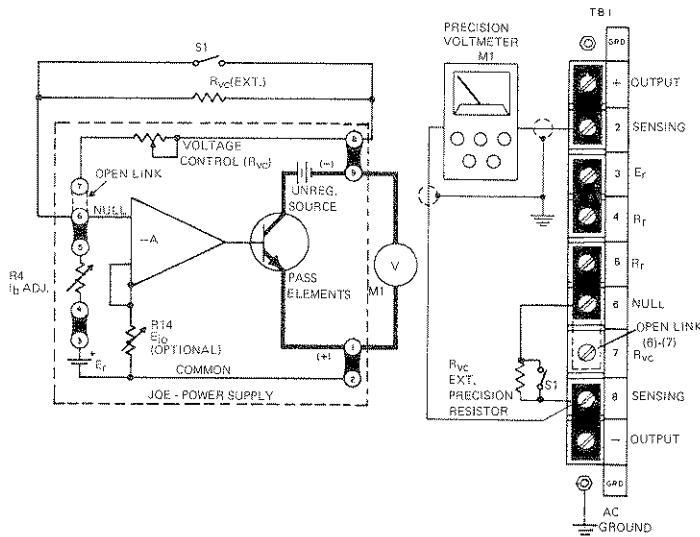

FIG. 3-5 CONNECTIONS FOR PRECISION PROGRAMMING RATIO ADJUSTMENT

- b) Connect calibration set-up as shown in FIG. 3-5 and connect the JOE power supply to the AC power line.
- c) With S1 "open", and $R_{VC} = 5\text{ K ohms}$, approximately 5 volts will be read-out on M1. Adjust " I_B Adj." (bridge current adjustment, R4, see FIG. 2-1 for location) until exactly 5 volts are read-out on M1.
- d) Close S1 and note deviation from zero on M1 (approx. 2 to 8 mV negative). Adjust " E_{IO} null" (zero adjustment, R14, see FIG. 2-1 for location) until exactly zero volts are read-out on M1.
- e) Open S1 and check the 5 volt reading. Repeat "C" and "D", as necessary to achieve the desired accuracy. FIG. 3-6 below shows graphically how the programming ratio can be precision adjusted.

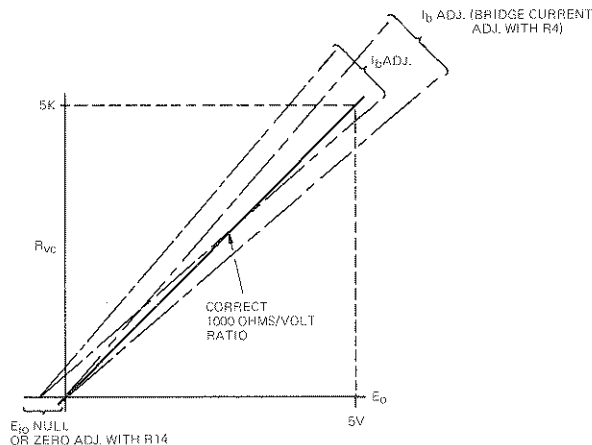

FIG. 3-6 ESTABLISHING PROGRAMMING LINEARITY

3-17 GENERAL RULES FOR REMOTE PROGRAMMING

3-18 All remote programming applications require the observance of a few basic rules to insure proper functioning of the power supply in the particular mode of operation selected. These rules should be remembered before each application and especially if malfunctioning of the programming set-up is experienced.

- 1) **GROUNDING.** Ground loops due to multiple and indiscriminate grounding of various equipment are the cause for the majority of complaints about "high ripple or noise". They can be easily avoided by grounding only the power supply at one point, to which all shielded cables and equipment cases are connected. If possible, one side (preferably the positive one) of the output of the power supply should also be grounded. Frequently, high ripple is introduced by programming sources or instruments used at the input (null junction) although all grounding rules have been observed. This may be due to the external instruments or source's close coupling to the AC line. In these cases only isolation (i.e. battery

operated devices) is the answer. It must also be remembered that input and output of the power supply are "common", so that if the output is not grounded, the input source must be isolated for the maximum output voltage to be programmed, plus the amount of voltage the common is "off ground".

- 2) CONNECTIONS. All external connections, especially the rear barrier strip terminal screws, must be tight. Serious malfunctions may be caused by open feedback loops or other open programming connections.
- 3) INPUT SOURCES. If specified performance is expected when remote programming, external input or reference sources must have specifications equal to or better than that of the power supply.
- 4) PROGRAMMING RESISTORS. Programming resistors should be high quality wirewound units with temperature coefficients of 20 parts per million or better. Their wattage rating must be at least 10 times the actual power dissipated. Although the control current through these resistors is only 1 mA, an error current exists when programming large voltage excursions. The magnitude of this error current equals the change in output voltage, divided by the final resistance of the programming resistor. (If, for example, the voltage step is from 50 volts to zero ($\Delta E_o = 50$ V), and the final resistance of the programming resistor is $\Delta R_{vc} = 2$ ohms, $I_{peak} = 25$ A.) The duration of the peak error current depends upon the size of the output capacitor. I_{peak} decays exponentially as the output voltage assumes the final value.

If step-switch devices are used in resistance programming, they must be of the "make before break" variety to avoid programming infinity. Programming resistors must have a voltage rating at least equal to the maximum output voltage of the power supply.

3-19 OUTPUT VOLTAGE PROGRAMMING WITH EXTERNAL RESISTANCE

The output voltage of the JQE Power Supply may be controlled remotely by an external resistance, replacing the built-in voltage control resistance which is disconnected at the rear barrier strip. The value of the programming resistance may be calculated by referring to the transfer function derived earlier (Eq.1):

$$E_o = R_{vc} \left(\frac{E_r}{R_r} \right)$$

Since $\frac{E_r}{R_r} = I_b$ (2), it follows that $E_o = I_b R_{vc}$ (3).

Referring to Equation (3), we see that since I_b is 1 mA in the JQE supplies (and can be precisely adjusted as shown in Par. 3-12), for every volt of output, 1000 ohms control resistance must be provided. This corresponds to a "Programming Ratio" of 1000 ohms per volt.

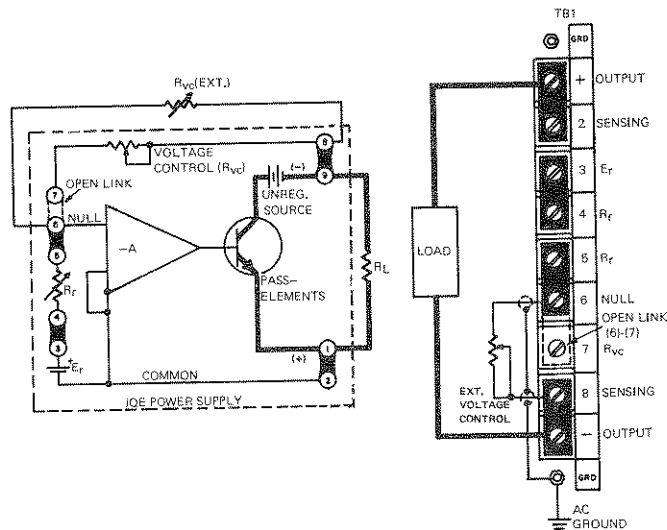

FIG. 3-7 REMOTE RESISTANCE PROGRAMMING

3-20 PROCEDURE (Refer to FIG. 3-7)

- a) Determine value of programming resistor(s) for output voltage desired.
- b) Using two-wire, shielded cable, connect the chosen resistors to terminals (6) and (8). Connect the shield to the "ground" terminal.
- c) The output voltage will vary from zero to $(1 \text{ mA}) \times (R_{VC})$, as R_{VC} is adjusted from zero to its maximum value.

3-21 PROGRAMMING BY CONDUCTANCE

3-22 For special applications, the output voltage E_O can be adjusted by varying the bridge current. The relationship governing this type of programming is:

$$E_O = E_r (R_{VC}) (G), \text{ (Eq. 4)}$$

$$\text{Where: } G = \frac{1}{R_r + R_x} = \text{programming conductance.}$$

$$\text{or } E_O = \frac{E_r}{R_r + R_x} \times (R_{VC})$$

- E_O = output voltage
- E_r = reference voltage
- R_{VC} = control resistance
- R_r = reference resistance
- R_x = programming resistor

Since $\frac{E_r}{R_r} = I_b$ and $E_O = I_b R_{VC}$ the output voltage varies directly as I_b changes. Changing I_b with the help of an additional resistor in series with R_r results in an inversely proportional change of I_b , since now

$$I_b = \frac{E_r}{R_r + R_x}$$

This method of output voltage adjustment is therefore referred to as conductance programming.

3-23 Conductance programming is a reciprocal function when analyzed in terms of resistance, but perfectly proportional

$$\left(E_O \propto \frac{1}{R_x} \right).$$

It can be very useful, especially over a limited range and for small changes in output voltage. Another distinctive advantage of this type of programming is the "built-in" safety feature. Should the programming circuit open accidentally, the programming resistance becomes infinite, the conductance is zero, and consequently, the voltage becomes zero.

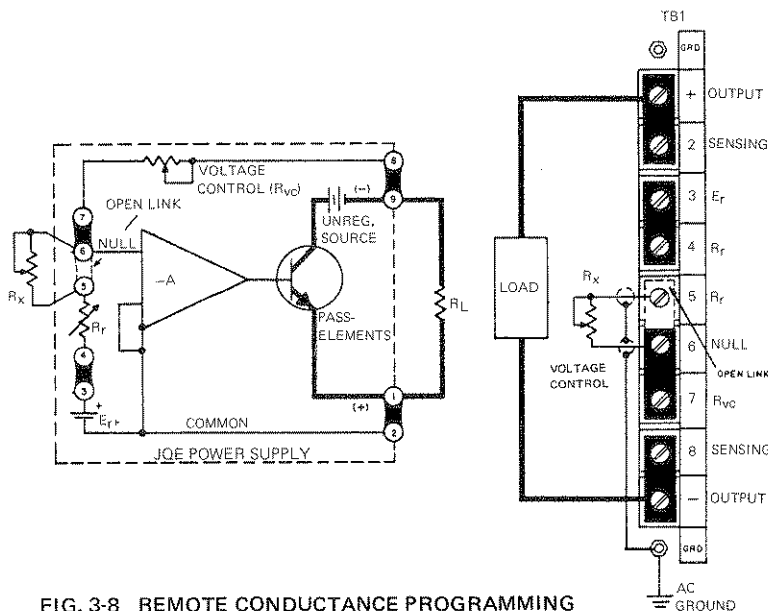

FIG. 3-8 REMOTE CONDUCTANCE PROGRAMMING

3-24 PROCEDURE (Refer to FIG. 3-8)

EXAMPLE: E_O desired = 3 to 5 volts.

- a) Select R_{VC} for maximum desired output voltage E_O .

$$R_{VC} = \frac{E_O}{I_b}, \quad R_{VC} = \frac{5 \text{ V}}{1 \text{ mA}} = 5 \text{ K ohms.}$$

- b) A change of E_O to 3 volts requires a bridge current change of:

$$\Delta I_b = \frac{\Delta E_O}{R_{VC}} = \frac{2 \text{ volts}}{5 \text{ K ohms}} = .4 \text{ mA}$$

- c) Since $I_b = \frac{E_r}{R_r} = 1 \text{ mA}$, the additional resistance needed is:

$$I_b (R_r + R_x) = E_r, \quad R_x = \frac{E_r}{I_b} - R_r \text{ or } R_x = \frac{6 \text{ volts}}{0.6 \text{ mA}} - 6 \text{ K} = 4 \text{ K ohms.}$$

A 4K ohm, WW, low T.C. potentiometer will change the output voltage from 3 to 5 volts when varied from zero to 4K ohms.

NOTE: A word of caution may be in order in regard to the changing of the bridge current. The 1 mA value has been selected for maximum stability in the zener reference circuit. A large departure from this value is not advisable. If a $\pm 50\%$ change in I_b is not sufficient to achieve the desired voltage swing, an external reference supply can be used.

3-25 REMOTE PROGRAMMING WITH EXTERNAL CONTROL VOLTAGE

- 3-26 The output voltage of the power supplies in the JQE group may be controlled by an external, variable voltage source, which supplies the necessary control current, formerly delivered by the (now disconnected) internal, fixed reference source. This mode of operation is termed "Voltage Programming". It can be mathematically expressed by referring to basic equation (1):

$$\frac{E_O}{E_r} = \frac{R_{VC}}{R_r} \quad (\text{Eq. 1})$$

Solving for E_O , and designating the external programming components " E_i, R_i ", the result is:

$$E_O = -E_i \frac{R_{VC}}{R_i} \quad (\text{Eq. 5})$$

- 3-27 As seen from the expression (Eq.5), if the ratio R_{VC}/R_i (which represents the closed loop gain of the system) is held constant, E_O will vary linearly with E_i , the external programming voltage. The above expression (Eq 5) is seen to be similar to the operational amplifier transfer function in the inverting configuration. The voltage programmed power supply does in fact become a unipolar power amplifier with potentially very high power gain but with limited frequency response. (Refer to FIG. 3-9). The limited frequency response is largely due to the effect of the output capacitor (C_O) acting as a low-pass filter and preventing the output voltage (E_O) from varying rapidly. The output voltage may be varied over the full range, bounded on the high end by the maximum rated value. A practical example to illustrate component selection will be given below.

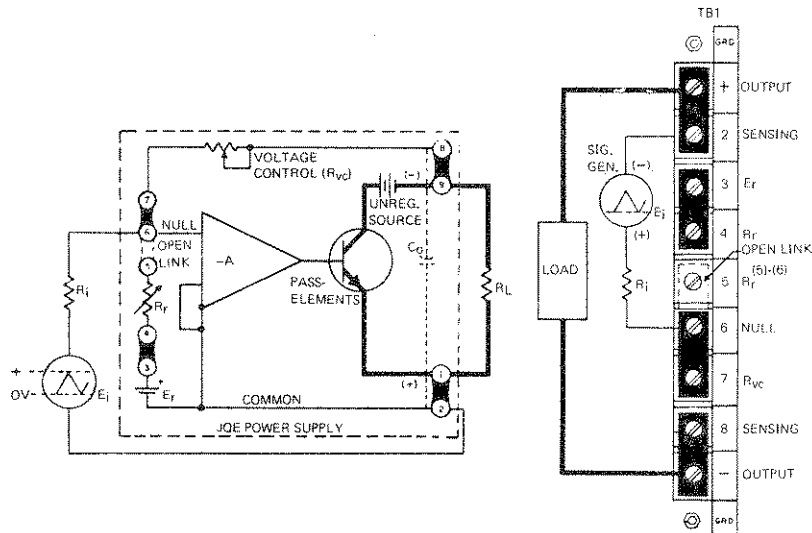

FIG. 3-9 JQE IN THE OPERATIONAL AMPLIFIER MODE

3-28 Example: A Kepco Model JQE 36-3M is to be voltage programmed over its full range (0 to 36V) by a triangular, positive increasing source with a peak output voltage (E_i) of 2 volts, and able to deliver at least 1 mA control current. Since the required voltage gain is: $E_o/E_i = 36/2 = 18$, the ratio R_{Vc}/R_i must also equal 18. If the internal voltage control is retained, in this case, since $R_{Vc} = 40$ K ohms, R_i must equal 40 K/18 = 2.22 K ohms. FIG. 3-9 shows the JQE Power Supply as an operational amplifier and the necessary rear barrier connections for this mode of operation.

3-29 CONSTANT CURRENT OPERATION

3-30 The JQE power supply can be set up to deliver constant current by the addition of an external sensing resistor and a current control. In the constant current operating mode, the voltage comparison bridge is interconnected with an external current sensing resistor, R_s , and a current control, R_{CC} , (as shown in FIG. 3-10) to maintain a constant voltage drop across R_s . In this way, an adjustable constant load current is obtained. Characteristic of the constant current supply is ability to change its output voltage automatically in order to maintain a constant current through a range of possible load resistances. The range of output voltage that the supply can deliver and simultaneously maintain constant current, is referred to as the "COMPLIANCE VOLTAGE".

3-31 The current sensing resistor R_s is chosen to develop a 1 volt drop at the maximum desired current. It is calculated by dividing this current into one volt. The value of R_s is not critical and can be the nearest standard resistance available. Several facts should be kept in mind however, when choosing R_s . A compromise must be made between a large and a small value. While a large value is desirable for good current regulation, it is less so in view of the power dissipated across it. It must be remembered that all the load current is flowing through R_s and the input to the regulator is connected across it. It is therefore vital that all extraneous changes across R_s , i.e. resistance change due to temperature, are kept to a minimum. A high quality, low T.C. (20 PPM) resistor, at least ten times the actual wattage needed, is therefore strongly recommended. In practice, R_s is usually selected for a 1 volt sample at maximum output current desired. If more than a 10:1 ratio of output current is needed several values of R_s should be selected and switched in or out as required.

3-32 The current control resistor, R_{CC} , is chosen on the basis of the control ratio of the Kepco comparison bridge, and V_s , the maximum voltage across R_s . If R_s was selected for 1 volt drop, then $V_s = 1$ volt and $R_{CC} = V_s$ times (control ratio), or

$$R_{CC} = 1 \text{ volt} \times \frac{1000 \text{ ohm}}{1 \text{ volt}} = 1000 \text{ ohms.}$$

A high quality, low T.C. (20 PPM) resistor is recommended for R_{CC} .

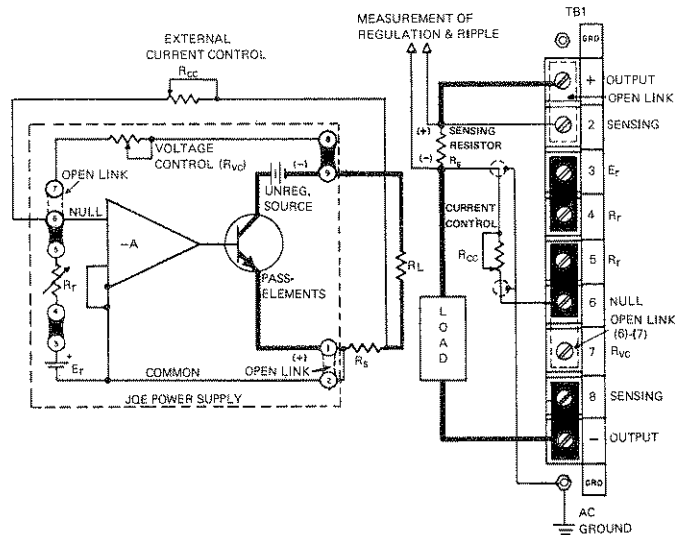

FIG. 3-10 CONSTANT CURRENT OPERATING MODE

3-33 PROCEDURE (Refer to FIG. 3-10)

The actual component calculation for current regulation is perhaps best shown by a practical example. A JOE 100-1M is to be set up for current regulated output from 30 mA to 300 mA. (1:10 ratio).

a) R_s is chosen by: $R_s = \frac{1 \text{ volt}}{0.3 \text{ A}} = 3.33 \text{ ohm.}$

$P_{\text{diss}} = V_s \times I_{\text{max.}} = 1 \text{ volt} \times (0.3 \text{ A}) = 0.3 \text{ watts.}$

Three 10 ohm, 1 W, wire-wound resistors connected in parallel will be satisfactory.

b) The control resistance R_{CC} is found by calculating its limits:

$R_{CC} (\text{max.}) = V_s (\text{max.}) \times \text{control ratio} = 1 \text{ V} \times \frac{1000 \text{ ohms}}{\text{V}} = 1000 \text{ ohms.}$

$R_{CC} (\text{min.}) = V_s (\text{min.}) \times \text{control ratio} = 0.1 \text{ V} \times \frac{1000 \text{ ohms}}{\text{V}} = 100 \text{ ohms.}$

As R_{CC} is therefore varied from 100 ohms to 1000 ohms, the regulated current will vary from 30 to 300 mA. The compliance voltage will change in the same ratio (10:1), its absolute value depending on the load resistance used.

c) The full output current range (1 mA to 1 A) could be covered if three separate sensing resistors were to be calculated and switched into the sensing circuit. Each would cover a range of 10:1, and all would be calculated on the basis of a 1 volt sample at maximum current:

a) R^1_s (for 0.1 to 1 A) = 1 V/1 A = 1 Ω (10 watt).

b) R^2_s (for 0.01 A to 0.1 A) = 1 V/0.1 A = 10 Ω (1 watt).

c) R^3_s (for 1 mA to 0.01 A) = 1 V/0.01 A = 100 Ω (1 watt).

3-34 SERIES OPERATION

3-35 General. Kepco JOE Power Supplies can be series-connected for increased voltage output, provided the specified limits on voltage to chassis are not exceeded. When series-connected, the supplies should be protected by means of a semi-conductor diode across the output terminals of each power supply, as shown in FIG. 3-11. The peak inverse rating of these diodes must be at least as large as the output voltage of the supply to which they are connected. The continuous current rating of the diodes should be at least as great as the largest short-circuit current of the interconnected supplies.

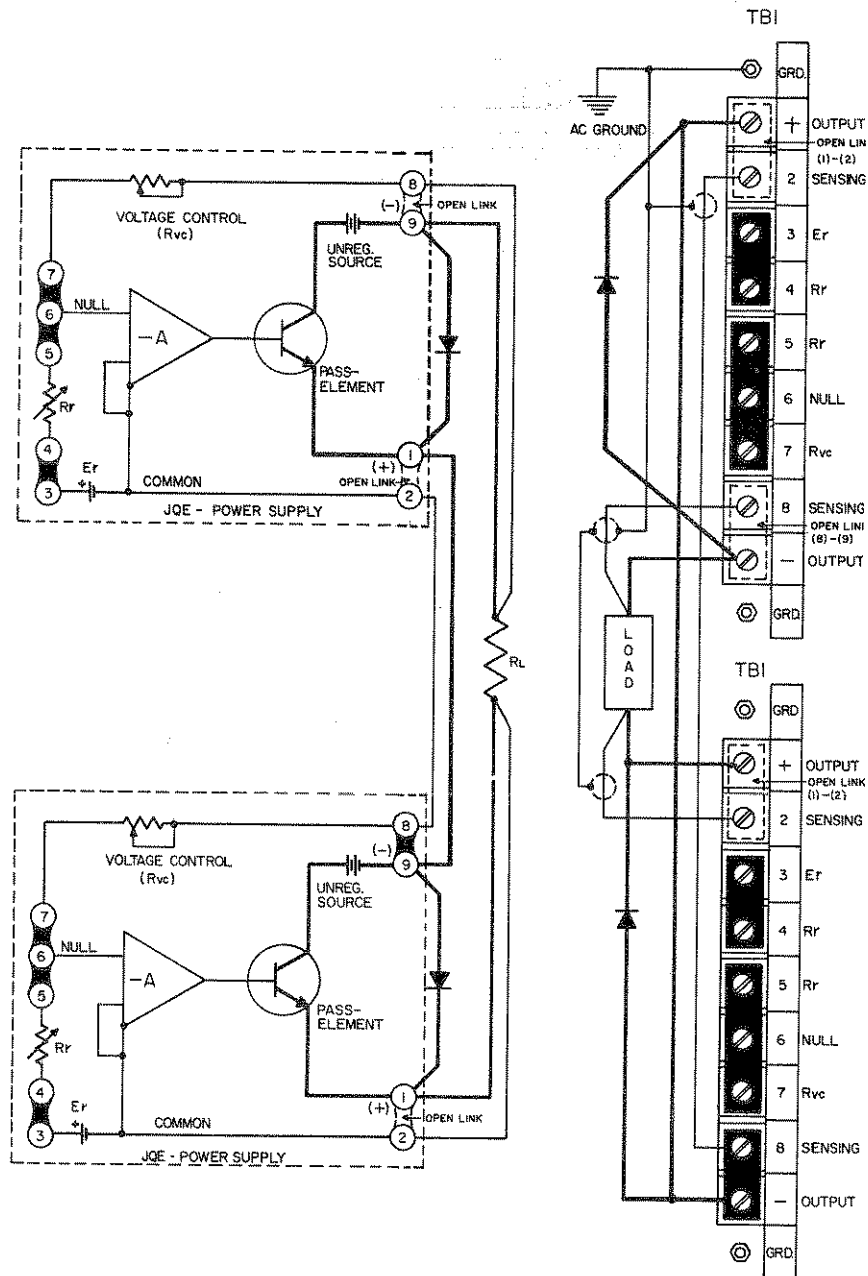

FIG. 3-11 AUTOMATIC SERIES CONNECTION OF JQE POWER SUPPLIES

3-36 PROCEDURE

- Connect load as shown in FIG. 3-11. Keep voltage drop in load wires as low as practical by using heavy gauge wire.
- Connect protective diodes across respective output terminals.
- Remove jumpers as shown and connect error sensing leads. These leads carry negligible current and can be approximately #18 gauge wire.
- Turn supplies on and adjust voltage on either control as required.

3-37 An alternate method of series connecting two or more power supplies is shown in FIG. 3-12. The basic difference between the "Automatic" series connection, shown in FIG. 3-11, and the "Master-Slave" connection (FIG. 3-12) is that with the former connection the outputs of both supplies may be controlled or programmed individually, while with the latter method only the "Master" supply is controlled while the "Slave" supplies follow the command of the "Master" in a ratio which may be pre-determined by the user. The "Master-Slave" series connection is therefore often termed an "Automatic Tracking" configuration.

3-38 The principle of operation of the "Master-Slave" series connection is as follows:

As seen from FIG. 3-12, the reference voltage of the "Slave" supply is disconnected and its input (null junction) is connected to the output of the "Master" supply. Since the control current for the "Slave" supply is thereby derived from the "Master", the "Slave" output is thus completely dependent on the "Master" supply output:

$$E_{Os} = E_{Om} \frac{R_{Vcs}}{R_t} ;$$

Where: E_{Om} = Output Voltage, Master

E_{Os} = Output Voltage, Slave

R_t = Tracking Resistor

R_{Vcs} = Voltage Control Resistor, Slave.

As seen from the equation, if the tracking resistor (R_t) is made equal in value to the voltage control resistor of the "Slave" (R_{Vcs}), a tracking ratio of 1:1 is achieved, and the output of the "Slave" will equal that of the "Master". If a single load is connected to the series combination (FIG. 3-12), twice the "Master" output is applied to it, if separate loads are connected, identical voltages are applied to the individual loads. The ratio E_{Os}/E_{Om} can be readily changed if the application so requires by simply changing either R_{Vcs} or R_t .

3-39 PROCEDURE

- Connect load(s) as shown in FIG. 3-12.
- Remove jumpers as shown and connect error sensing leads if required.
- Turn supplies "on" and adjust output on the "Master" supply as required.

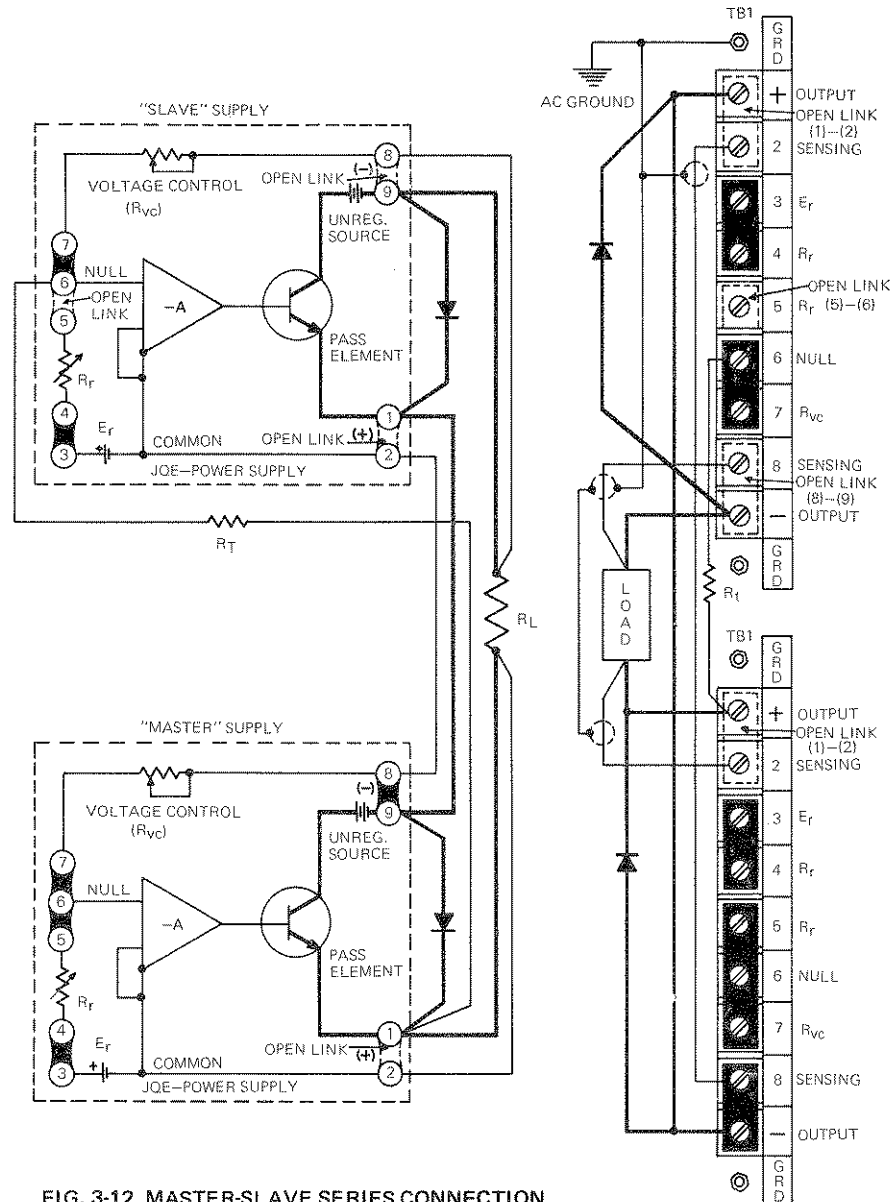

FIG. 3-12 MASTER-SLAVE SERIES CONNECTION
OF JQE POWER SUPPLIES

3-40 PARALLEL OPERATION

3-41 GENERAL. Kepco JQE Power Supplies can be parallel connected for increased load current output. As in the previously described series connections, an "automatic" or a "master-slave" connection method can be chosen. The basic difference between the two suggested methods are the manner in which the output is controlled. The "Automatic" method requires individual output control from each power supply, while with "Master-Slave" method single control is exercised from the "Master" supply. For either method some general rules apply which should be observed in paralleling power supplies:

- 1) Connect only supplies with identical compliance voltage range.
- 2) Error sensing (from either supply) may be used as shown in the diagrams. Close links if this is not desired.
- 3) Load wires should be as short as practicable. Select the wire gage as heavy as possible and twist tightly. Approximately equal lengths of wire should be used.
- 4) Common AC power turn-on for all supplies is recommended.

3-42 AUTOMATIC PARALLEL CONNECTION. Each supply is set approximately to the desired output voltage with its respective Current Limiting Adjustment at factory adjusted value (105% I_O max.). After paralleling the two power supplies, one of the (supply #1) will inherently be at a slightly higher output voltage than the other (supply #2). Consequently, supply #1 will deliver all the load current up to the setting of its Current Limiting Adjustment. As the load is increased beyond this limit of supply #1, supply #2 takes over and delivers the additional current. The Current Limiting Adjustment of supply #1 can now be decreased, so that approximately equal current sharing is obtained. FIG. 3-13 shows in form of a diagram, how the two supplies operate in parallel, with their respective Current Adjustments at the factory adjusted value (105% I_O max.). It will be obvious from the diagram, that the areas of load regulation are within the output current bands of the individual supplies. Therefore, load regulation cannot be measured from zero to twice the load current for example, but only within the individual load currents bands. Error sensing as described in par. 3-4, from the supply operating in the "constant voltage" mode, supply #2 in the example may be used if precise regulation at the load is required.

CAUTION

When using the "AUTO-PARALLEL" method, care should be exercised to avoid turning the voltage control of only one supply close to zero. This precaution is necessary to prevent possibly damaging currents in the voltage control resistor as its limiting resistance is lowered.

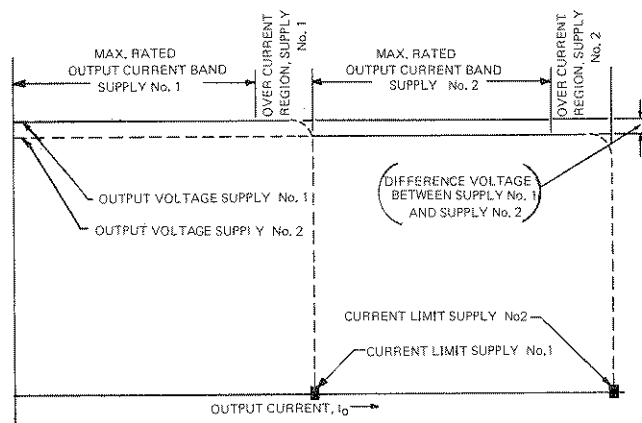

FIG. 3-13 PARALLEL OPERATION, JQE SUPPLIES

3-43 PROCEDURE (Refer to FIG. 3-14)

- a) Connect units as shown in FIG. 3-14. Open SW-1 and connect to line.
- b) Adjust both units to the approximate output voltage desired.
- c) Close SW-1. Observe load current meters M1 and M2. Adjust Current Limit Control on the unit showing the higher current on its load current meter. Turn Current Limit Control counter clockwise until currents on M-1 and M-2 are approximately equal.

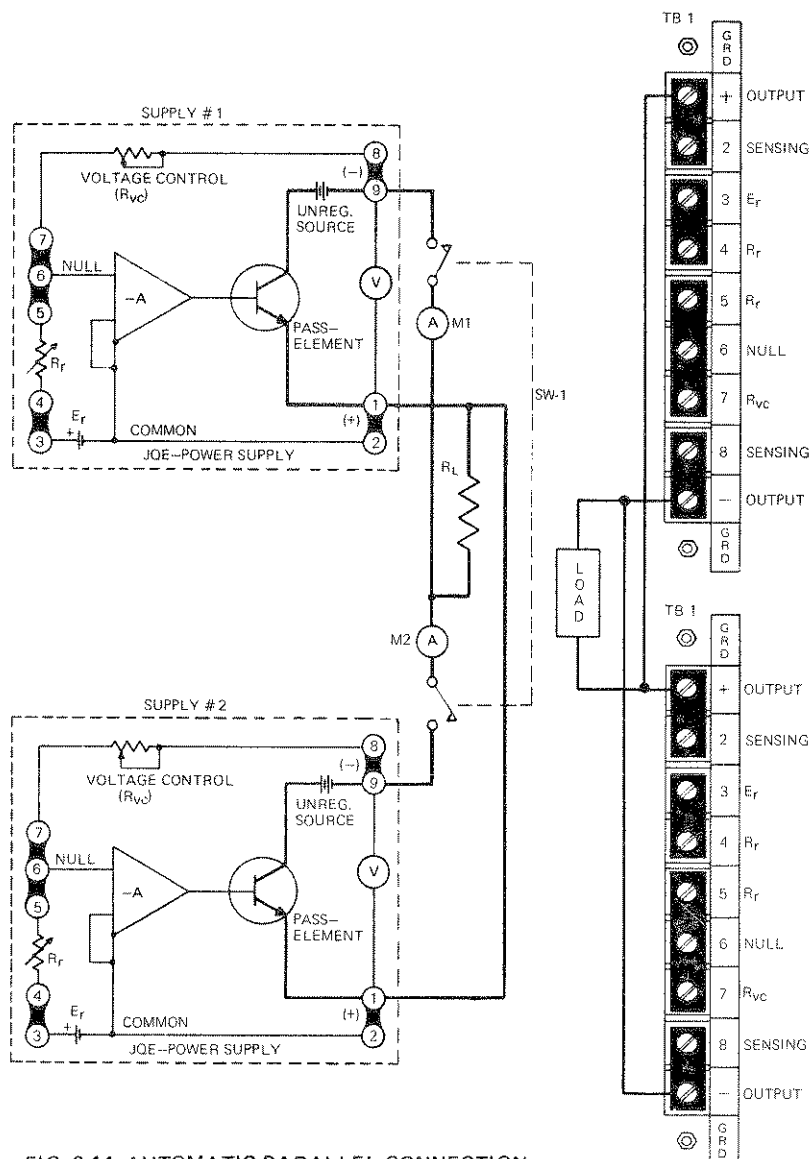

FIG. 3-14 AUTOMATIC PARALLEL CONNECTION OF JOE POWER SUPPLIES

3-44 MASTER-SLAVE PARALLEL OPERATION. Kepco Power Supplies may be paralleled if the output current from a single supply is not sufficient for the application at hand. With the parallel connection shown in FIG. 3-15, the total output current of the parallel supplies may be controlled from a single "Master" supply. To operate the parallel supplies in the "Master-Slave" connection, sensing resistors of equal value must be selected (R_{S1} , R_{S2} in FIG. 3-15) such that the voltage drop across them is about 0.1 to 0.25 volts at the output current of interest. The *sum* of the voltage drops across the load wire with the sensing resistor in series should *never exceed 0.5 volts* at the maximum desired operating current. If sensing resistors of the proper value are not available, the resistances of the load wires may be used to establish the necessary voltage drops. In this case, the load wires should be trimmed such that *equal voltage drops* are established in the lead from the "Master" and that from the "Slave" supply. Load wires should in general be of as heavy a wire gauge as practicable. Twisting of the load wires, as well as of the error sensing leads from the "Master" supply (although *not* shown in FIG. 3-15) is recommended.

3-45 PROCEDURE FOR "MASTER-SLAVE" PARALLEL CONNECTIONS

- Select external current sensing resistors (R_{S1} , R_{S2}) as described.
- Connect supplies as shown in FIG. 3-15, keeping load and error sensing leads as short as possible. Use shielded wire for the connection from terminal (2) of the "Master" to terminal (6) of the "Slave" unit.
- Connect supplies to common AC power line and use common power switching.
- After turn-on, output voltage can be adjusted on the Voltage Control of the "Master" supply and operation can commence.

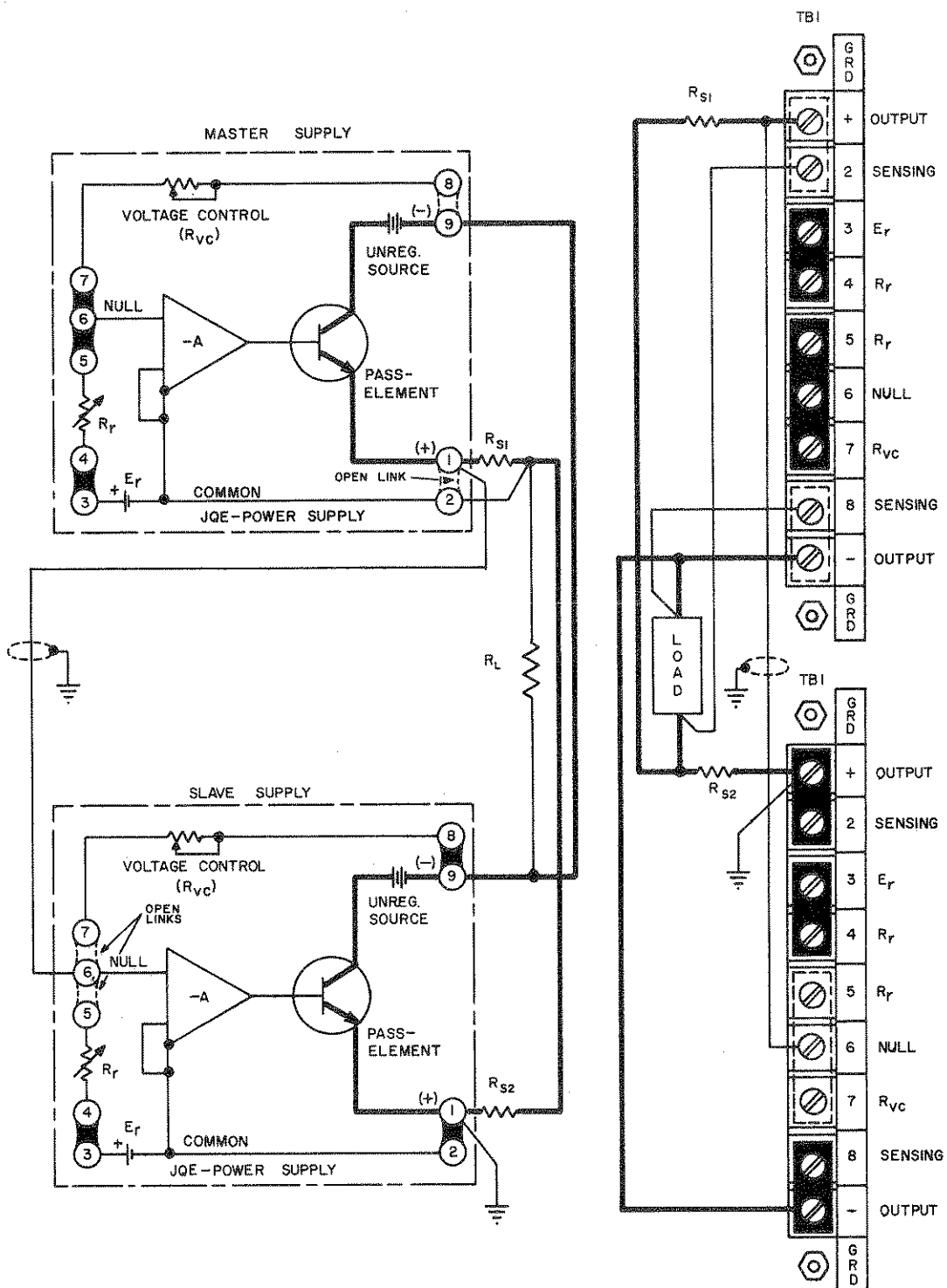

FIG. 3-15 MASTER-SLAVE PARALLEL CONNECTION OF JQE POWER SUPPLIES

SECTION IV – THEORY OF OPERATION

(References in CAPITAL LETTERS refer to the nomenclature used in FIG. 4-1)

4-1 SIMPLIFIED DIAGRAM DISCUSSION (Refer to FIG. 4-1)

- 4-2 The MAIN POWER TRANSFORMER converts the line voltage to the required levels needed to produce the DC operating voltages for the MAIN AND AUXILIARY SUPPLIES. The MAIN POWER SUPPLY is in series with the PASS ELEMENTS and the CURRENT SENSING RESISTOR and produces the output voltage. The MAIN PASS ELEMENTS are changing their series resistance in a way tending to keep the OUTPUT VOLTAGE constant. The necessary drive for this change is produced by the DRIVER CIRCUIT which in turn receives its command signals either from the CURRENT LIMIT AMPLIFIER or the ERROR SIGNAL AMPLIFIER.
- 4-3 The OUTPUT VOLTAGE is constantly compared to the REFERENCE SOURCE, while the output current is monitored by the CURRENT SENSING resistor. Any change, in either output voltage or current, is amplified by the associated amplifier and transferred to the GATE DIODES which feed directly into the DRIVER CIRCUIT and produce the needed drive signal for the MAIN PASS ELEMENTS, thus either keeping the OUTPUT VOLTAGE constant, or if the signal from the CURRENT LIMIT AMPLIFIER is dominant, limiting the output current to the pre-adjusted value.

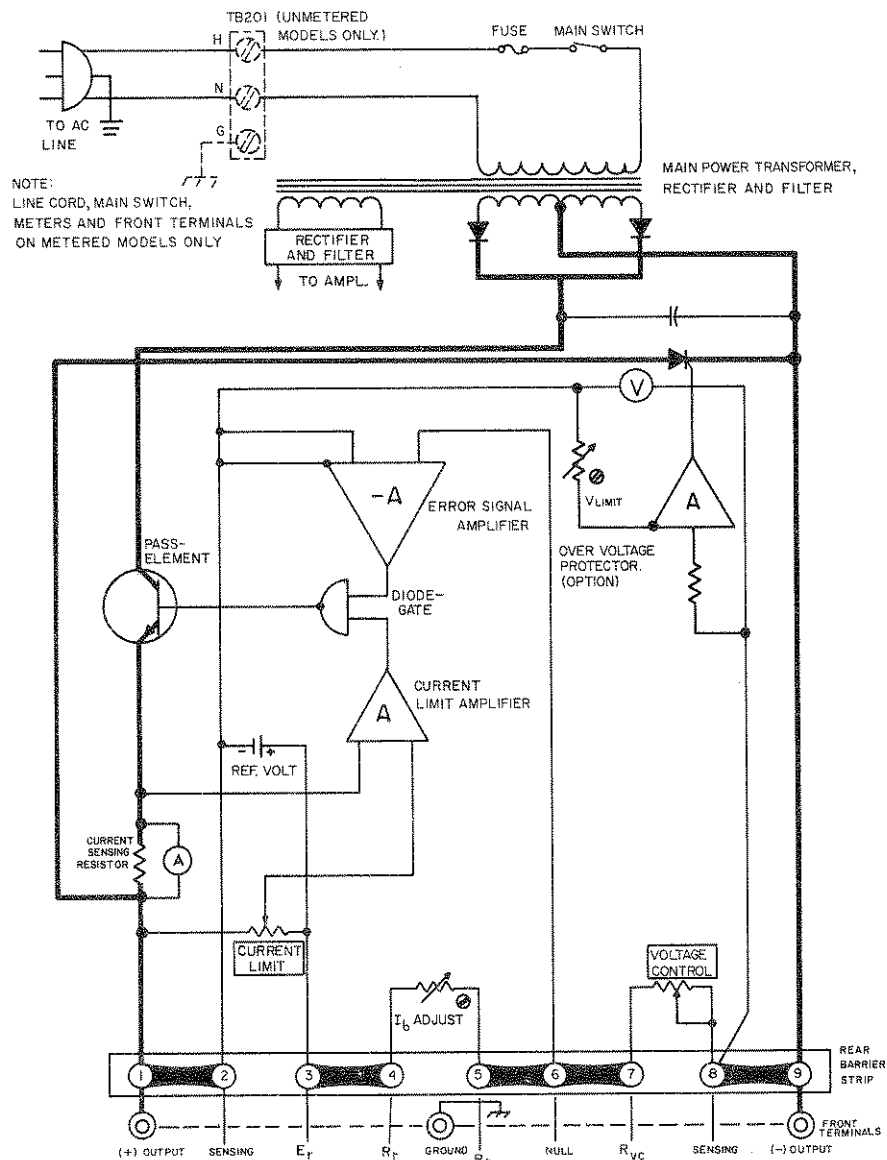

FIG. 4-1 JOE SIMPLIFIED DIAGRAM, AND REAR CONNECTIONS

4-4 The OVERVOLTAGE PROTECTOR (Optional, on models with suffix "VP" only.) is connected across the output terminals of the power supply. A portion of the output voltage is continuously compared to an internal reference. If an overvoltage occurs, the S.C.R. "crowbar" will short-circuit the output immediately. Recycling takes place after the AC input voltage has been removed from the power supply.

4-5 CIRCUIT DESCRIPTION

4-6 For the purpose of analysis, the circuitry of the JQE power supply may be divided into several sections which are individually described below. The main schematic (FIG. 6-1) should be used to illustrate the text of this section.

- a) AC INPUT CIRCUIT. AC line power is introduced through the (detachable) three-wire line cord with safety plug.* The use of a grounded AC power outlet will automatically ground the power supply, since the third wire of the line cord is directly connected to the metal chassis and case. Once the AC power switch (S101)* is closed, the primary of the main transformer (T201), the fan (B201) and the AC pilot light (DS101)* will be energized. The two primary windings of the main transformer are either connected in parallel (for 115V AC nominal line voltage) or in series (for 230V AC nominal line voltage). A slow-blow type fuse (F201)* protects the primary circuit from excessive current.
- b) MAIN DC SUPPLY. The main DC power is derived from a center-tapped secondary winding on T201. A full-wave rectifier circuit with silicon diodes CR301, CR302 (located on the Heat Sink Assembly) works into a capacitor input filter (C201), paralleled by a bleeder resistor (R201). The main DC supply delivers the output current through the series regulator or pass elements.
- c) SERIES REGULATOR (PASS-ELEMENTS). The series regulator transistors (Q301,302,303,304) are NPN silicon devices, located on a specially constructed heat sink (A3) and cooled by the fan (B201). Electrically, these pass transistors are connected in series with the (unregulated) main DC supply and the output. The effective series resistance of the pass transistors (and thereby the voltage drop across them) is changed in such a way as to keep the output voltage constant, regardless of variations in the unregulated main supply. The base drive needed to affect this change in the pass transistors is supplied by the main driver (Q305), also located on the heat sink assembly.
- d) ERROR SIGNAL AMPLIFIER (A_V). The main function of this DC amplifier is to amplify the error signal, derived from the comparison bridge, to a level suitable to pass the diode gate circuit and drive the pre-driver stage (Q1). The error signal amplifier in the JQE power supply is a DC coupled, high gain operational amplifier in a plug-in package. The amplifier input may be disconnected from the comparison bridge circuit, and programmed externally. Although the plug-in amplifier is used in the non-inverting configuration, a positive input signal will produce a negative power supply output with respect to the "common" (plus (+) sensing terminal), since the pass-elements provide another signal inversion.
- e) COMPARISON BRIDGE. This four-arm electrical bridge circuit is the sensing and controlling element in the JQE power supply. The reference-half of the bridge consists of the reference resistors in series with the zener reference voltage ($R_r = R4, R5$; $E_r = CR201$), the other half is constituted by the voltage control resistor ($R_{VC} = R102$) and the output voltage (E_O). The simplified presentation shown in Section III of this manual will illustrate this discussion and show the actual bridge configuration. (Refer to FIG. 3-4). The output voltage (in series with R_{VC}) is continuously compared with the reference half of the bridge circuit. At bridge balance ($E_{AA'} = 0$), a constant bridge current (I_b) is flowing through the bridge, keeping the error signal at the bridge terminals (A,A') at approximately zero volts. Any deviation in the output voltage (E_O), caused either by line/load variation or by a change in R_{VC} will tend to change the bridge current (I_b) in the sensing half of the bridge and thereby produce an error signal at the bridge terminals (A,A'). The error signal is presented to the amplifier input and will after amplification, act as a drive for the pass transistors, changing the voltage drop (E_p) across them in such a way as to restore bridge balance and keep the output voltage (E_O) constant once more.
- f) CURRENT LIMIT CIRCUIT. The differential input of the current limit amplifier (Q3,Q4) is connected to the current sensing resistor ($R_s = R307$) and to a reference voltage, adjustable by the current limit control (R101). The voltage drop across the current sensing resistor is thus continuously compared to the reference voltage, set by the current limit control. As long as the voltage developed across R_s (due to load current flow) is less than the pre-set voltage reference level, the current limit amplifier will be biased to its inactive state and will not effect the output. If the output current increases however, the voltage drop across R_s will overcome the reference level set by the current limit control. The current limit amplifier will be thus activated and produce a drive signal at the diode gate, greater than A_V .

*These components on metered models (suffix "M") only. Line power on unmetered models is introduced via a rear barrier-strip (TB203). The grounding terminal on TB203 (G) should always be returned to AC ground.

thereby taking control away from the error signal amplifier and transferring the power supply into the current limit mode. Since both, the current limit amplifier and the error signal amplifier (A_V) are coupled through the diode gate circuit (CR13,14) to the pre-driver stage (Q1), the amplifier with the greater (negative) output will control the pass transistors and therefore the output.

g) OVERVOLTAGE PROTECTION CIRCUIT (Models with suffix "VP").

- 1) The overvoltage protector circuit contains its own reference voltage, to which a portion of the power supplies output voltage is continuously compared. In the balanced condition, the sensing voltage is approximately equal to the reference voltage and the circuit remains inactive. Should the sensing voltage, due to a rise in output voltage, at any time exceed the reference level, the Schmitt-Trigger stage (Q403,404) will produce a signal, which transferred through the emitter follower (Q402), will turn the driver stage (Q401) "on". The amplified signal passes through the coupling zener diode (CR402) to the gate of the "crowbar" (silicon controlled rectifier). Once the "crowbar" S.C.R. is fired, a short circuit is placed across the output. The main fuse will blow only if the cause of the overvoltage was a shorted element or a similar internal defect. If the overvoltage protector triggers due to other causes, the power supply will continue to operate into a short circuit until the cause for the overvoltage is removed and the protector circuitry is reactivated by momentarily switching the AC power "off".
- 2) Input and output connections for the over voltage protector (VP) are made via the printed circuit connector (P401) and its associated mating jack (J204). The VP contains its own auxiliary power supply, only the AC voltage is derived from a secondary winding on T201, and introduced via J204/P401. The AC is rectified by a conventional bridge rectifier (CR401) and capacitor filtered (C401). The rectified and filtered DC is zener regulated by CR404. The reference voltage is derived from the pre-regulated DC, thus providing a stable reference source (CR405).
- 3) The Schmitt-Trigger Stage (Q403,404) functions as a voltage comparator or sampling circuit by causing Q403 to change states as the base voltage of Q404 is altered. Since the collector voltage of Q404 is rigidly clamped to a stable reference, a positive base signal from the divider (due to overvoltage) will result in a change of stat in Q403, and subsequently in a signal to the coupling zener (CR402) and to the gate of the crowbar S.C.R. (CR403). The delay adjustment capacitor (C403) is an adjustable trim capacitor, its value determining the charging time constant at the output of the Schmitt-Trigger. In effect, the setting of the capacitor determines the "sensitivity" of the VP to overvoltage signals. Minimum capacity will yield fastest response times (and also be more sensitive to spurious triggering). The control is factory adjusted for the fastest response consistent with stable operation under all conditions.
- 4) The crowbar S.C.R. (CR403) is connected to the output, so that a short circuit is provided, once the device is turned "on" by the action described above. Change of state of the overvoltage protector will only take place, when the AC power (and thereby the operating voltage for the VP) is completely removed from the power supply.

h) AUXILIARY SUPPLIES

- 1) AMPLIFIER POWER SUPPLY. This full wave, bridge rectified source is derived from a secondary winding on the main transformer (T201), rectified by CR7, the supply is capacitor filtered by C7. A current regulator stage (Q2), followed by a string of zener diodes (CR9-12), provides the operating voltage for the error signal amplifier (A_V), the current limit amplifier stage (Q3,Q4) and the reference circuit (R4,R5,CR201).
- 2) PRE-DRIVER COLLECTOR SUPPLY. A half wave rectified (CR3) and capacitor filtered (C2) supply is derived from a secondary winding on T201. It delivers collector voltage to the pre-driver stage (Q1). R3 is a bleeder and the network consisting of R24, C12, provides local feedback for the pre-driver stage.
- 3) ICBO SUPPLY. This full-wave rectified auxiliary supply is derived from the winding of the main power supply. Rectified by CR1 and CR2, and filtered by C1, the voltage is applied to the base of the main driver (via R1) and the pass transistors (via R202), thus insuring the necessary turn-off bias for these stages under all operating conditions, especially at elevated temperatures.

SECTION V – MAINTENANCE

5-1 GENERAL

5-2 This section covers maintenance procedures, installation of optional components, calibration and test measurements of the Kepco Model JQE Power Supplies. Conservative rating of components and the non-congested lay out should keep maintenance problems to a minimum. If trouble does develop however, the easily removed wrap-around cover and the plug-in feature of the circuit boards provide exceptional accessibility to all components of the supply.

5-3 DISASSEMBLY (Refer to FIG. 5-1)

- a) COVER REMOVAL. The wrap-around cover may be taken off by loosening and removing its nine (9) holding screws, three (3) on each side and two (2) on the front panel.
- b) CIRCUIT BOARD REMOVAL. The printed circuit board is mounted with three screws, two (2) of which are removed from the rear, one (1) from the side. After removal of the two printed circuit board connectors, the board may be lifted from its slide-guide.
- c) HEAT SINK REMOVAL. The heat sink assembly is mounted with two (2) screws to the chassis bottom. After the screws are taken out, the wires may be removed by means of the "quick disconnect" terminals.
- d) RE-ASSEMBLY. Re-assembly of all components takes place in reverse order of the above described procedures.

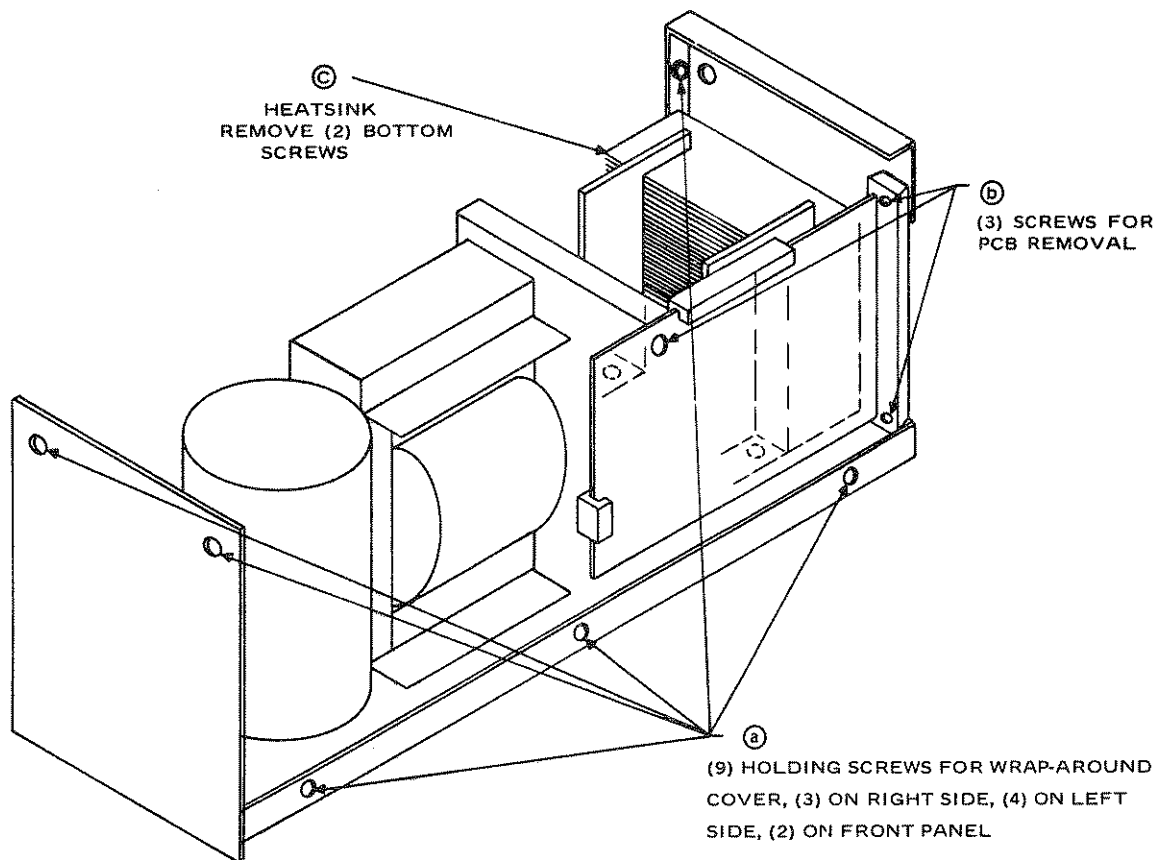

FIG. 5-1 DISASSEMBLY, JQE DESIGN GROUP

5-4 INTERNAL ADJUSTMENT PROCEDURES

5-5 GENERAL. This paragraph describes all internal adjustment procedures, which have not been previously covered. Refer to Section II, paragraph 2-3, for a listing and location of all adjustment procedures.

5-6 MAXIMUM OUTPUT CURRENT ("I_O max. adj.") ADJUSTMENT. This adjustment serves as a calibration for the range of the front panel Current Limit Control. The "I_O max. adj." (R19) is located on the printed circuit board (Refer to FIG. 2-1). It is factory set so that the front panel control covers an output current range of 10 – 105% of the maximum rated output current. Re-adjustment of the "I_O max. adj." control is needed only if a component in the current limit circuitry must be replaced or, if the range of the front panel control is to be restricted. A convenient way to make the adjustment is as follows:

- a) Load the output of the supply to draw the maximum desired output current with the front panel Current Limit Control fully clockwise. Monitor the output voltage with an oscilloscope, having a vertical sensitivity of at least 0.1 mV/cm.
- b) Observe the oscilloscope. Current limiting is indicated by a sharp increase in output ripple. Locate the "I_O max. adj." control and turn slowly until limiting occurs at the point required. Clockwise adjustment will increase the maximum output current range, while counter clockwise adjustment will decrease the range. DO NOT ADJUST TO MORE THAN 105% I_O max. Although this might be possible due to component tolerances, malfunction of the power supply will be caused by exceeding the rated maximum output current.

5-7 LAG NETWORK ADJUSTMENTS. An AC stability control in the form of a lag network has been provided in this power supply (R16, see FIG. 2-1 for location). This network has been factory adjusted for maximum amplifier stability when operating into a resistive load. Re-adjustment is indicated if components, affecting the AC characteristics of the amplifier must be replaced or, if the load connected to the power supply contains excessive capacity or inductance, causing AC instability. AC instability is usually indicated by high frequency oscillation as observed with an oscilloscope across the power supply load. In such cases, the lag network should be adjusted so that stable operation is resumed. If in extreme cases adjustment of the lag network should not prove sufficient, twisted load and error sensing wires or decoupling capacity directly across the load may provide a solution to the problem.

5-8 INSTALLATION AND ADJUSTMENT OF THE "ZERO" CONTROL

NOTE: Models which have this control factory installed carry the suffix "E" behind their model number (i.e. JOE 6-10ME). The installation instructions may be disregarded with these models.

5-9 A small (5–15 mV), negative offset voltage exists at the output of the power supply, with the voltage control set to "zero" (fully counter clockwise). Although this does not affect standard power supply operation, for precision remote programming, exact zero volt output may be necessary. The zero can be established by adding the necessary components on a pre-designated space on the printed circuit board.

5-10 The installation may be readily accomplished by following the steps indicated below:

- a) Remove the PCB Assembly from the chassis as described in paragraph 5-3. Locate the pre-designated space for the additional components on FIG. 5-2.

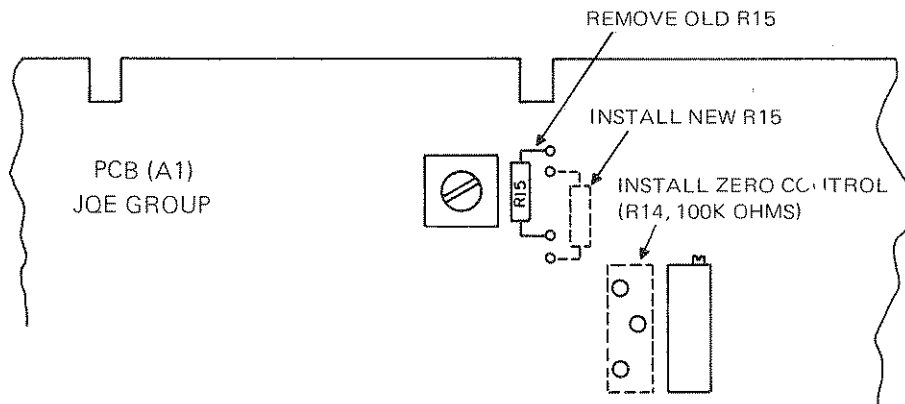

FIG. 5-2 INSTALLATION OF ZERO CONTROL

- b) Observing the standard precautions for soldering on printed circuit boards (Iron not above 60 W, No acid solder etc.) remove R15 (499 K) and replace with new value (10 ohm, metal film). Install 100K metal film rheostat into the space shown and solder components securely into place. This concludes the installation. Adjust precision zero as directed in paragraph 3-12 (Adjustments for Precision Programming Ratio).

5-11 TROUBLE SHOOTING

- 5-12 Modern, high performance power supplies have reached a state of sophistication that requires thorough understanding of the problems involved in repairing complex, solid state circuitry. Servicing beyond simple parts replacements should consequently be attempted only by personnel thoroughly familiar with solid state component techniques and with experience in closed loop circuitry.
- 5-13 Trouble-shooting charts, showing resistance and voltage readings, are of very limited usefulness with feedback amplifiers and are not included here. Instead a detailed circuit description (Section IV), parts location diagrams, simplified functional schematics and a main schematic with all significant voltage readings is presented.
- 5-14 The following basic steps in a case of power supply malfunctioning may also be found useful:
 - a) If power supply does not function at all: Check all powerline connections and fuses and make certain, power supply is connected to the correct line voltage (it is normally delivered for 115V AC operation).
 - b) If supply does not function in one of the remote programming modes, disconnect all external components and reconnect internal reference and the voltage control. The following paragraphs refer to the instrument as a power supply, rather than an amplifier in order to simplify test set-ups and measurements.
 - c) If the power supply is basically functioning, but poor performance is evident, inspect the test set-up to make certain the source of the trouble is not external.
 - d) Poor regulation in any of the regulating modes is usually traceable to incorrectly connected loads or faulty measurement techniques. Perform measurements as described in Paragraph 5-16 and follow the connecting diagrams.
 - e) Oscillation of the output voltage or output current is often due to a load with a large inductive component. Twisted loadwires of sufficient diameter and held as short as practical, are often the solution to the problem, if lag network adjustment does not correct the trouble. (Refer to par. 5-7).
- 5-15 KEPCO Field Engineering Offices or the KEPCO Repair Department will be available for consultation or direct help in difficult service or application problems.

5-16 POWER SUPPLY MEASUREMENTS

- 5-17 Measurement of the significant parameters of a power supply is a requirement for incoming inspection, periodic maintenance, or after component replacement. Since the measurements require special techniques to insure correct results, suggestions for Their performance are given below:
 - a) Require Instrumentation:
 - 1) Constant AC supply voltage with provisions for "stepping" the voltage over a specified region (105-125V); a variable autotransformer is generally adequate, if it is rated to deliver the input current of the unit under test.
 - 2) Resistive load, variable, with ON/OFF and SHORTING SWITCH and capable of dissipating the full output power of the unit under test.
 - 3) DC voltage monitor, differential voltmeter, or power supply analyzer.
 - 4) Current sensing resistor, for current regulation measurements, four-terminal device.
 - 5) AC ripple monitor, sensitivity better than 1 mV. Ballantine Model 302C, or Hewlett Packard Model 400H.
 - 6) Optional: Oscilloscope, vertical sensitivity better than 0.1 mV/cm.
 - b) FIG. 5-3 shows the proper location of instrument leads when measuring regulation. The principle governing this method of measurement is simply not measure any voltage drops due to load current flow. This can only be avoided by measuring regulation either directly at the sensing leads or by the use of four-terminal network. The four-terminal network can be approximated by the method shown in FIG. 5-3d.

- c) Voltage Regulation is defined as the amount of output voltage change resulting from a specified change of line voltage or from a change in load resistance. It can be expressed as an absolute change ΔE_O or as a percentage in reference to the total output voltage E_O :

$$\% \text{ Voltage Regulation} = \frac{\Delta E_O}{E_O} \times 100\%.$$

- d) Current Regulation is defined as the amount of output current change resulting from a specified change in line voltage or from a change in load resistance. It can be expressed as an absolute change ΔI_O , or as a percentage in reference to the total output current I_O :

$$\% \text{ Current Regulation} = \frac{\Delta I_O}{I_O} \times 100\%.$$

- e) Ripple, RMS ripple may be monitored on a true RMS reading instrument connected parallel to the regulation analyzer leads. Careful wire dressing and shielding, as well as good AC grounding are of the utmost importance if valid measurements are being expected. An oscilloscope may also be used for P-P readings of noise and ripple. An approximate RMS reading can be calculated from the P-P reading of the oscilloscope if the reading is divided by three.

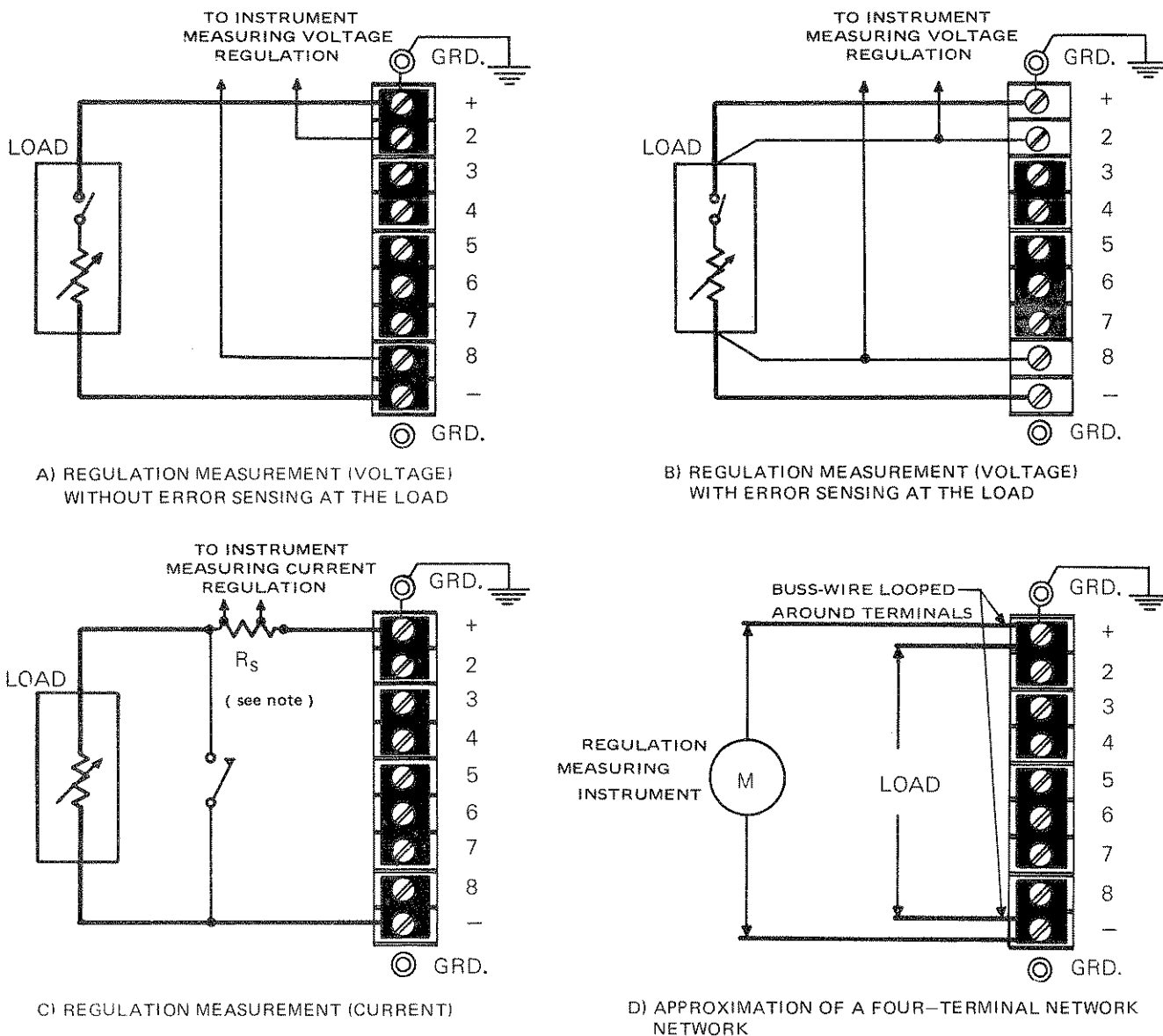

*NOTE: R_s should be selected such that its wattage rating is at least 10 times the actual power dissipated. Stability and regulation depend on the stability of R_s . Recommended T.C. for R_s is 20 ppm.

FIG. 5-3 CONNECTIONS FOR POWER SUPPLY MEASUREMENTS

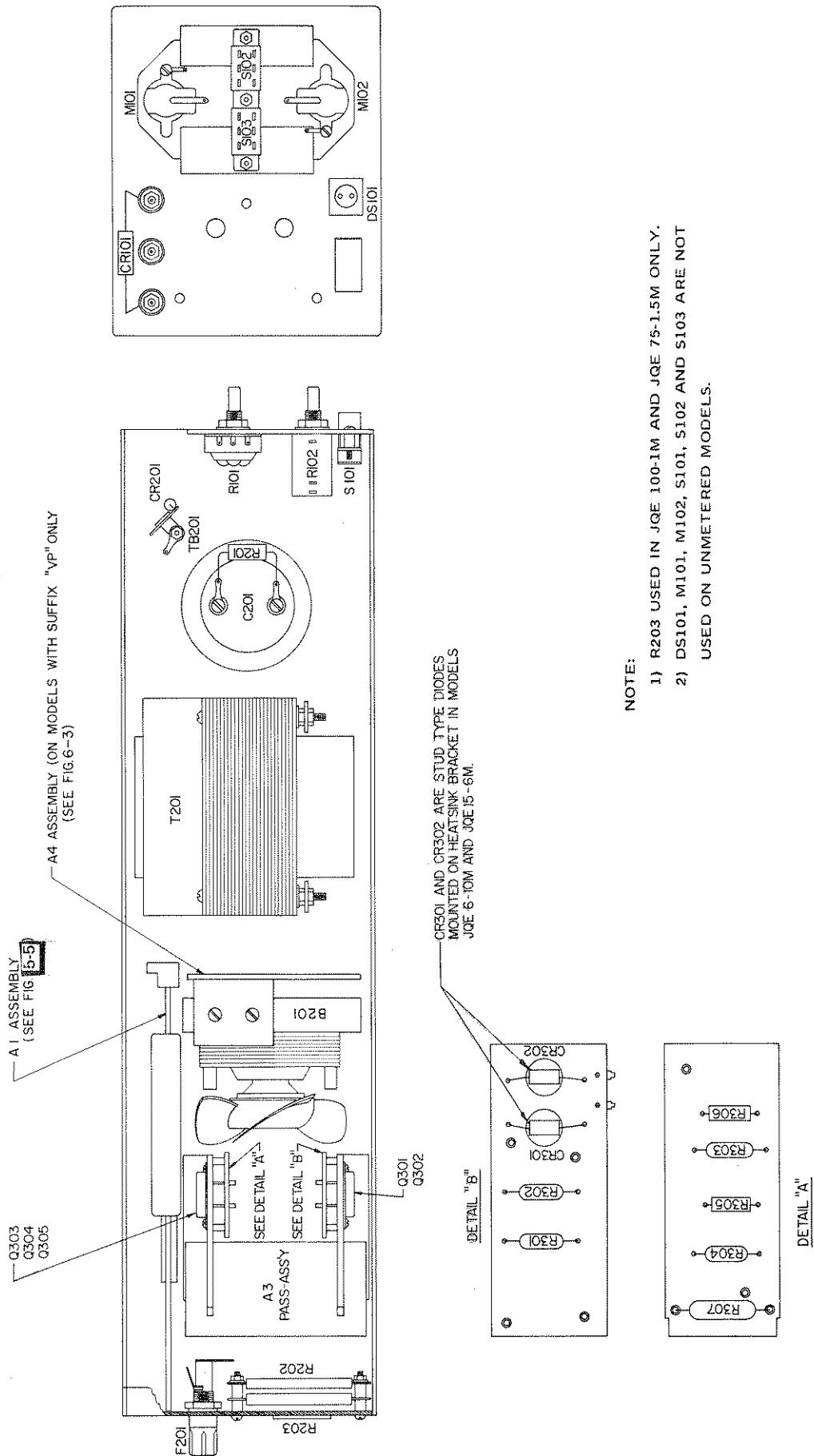

NOTE:

- 1) R203 USED IN JQE 100-1M AND JQE 75-1.5M ONLY.
- 2) DS101, M101, M102, S101, S102 AND S103 ARE NOT USED ON UNMETERED MODELS.

FIG. 5-4 MAIN CHASSIS, COMPONENT LOCATION

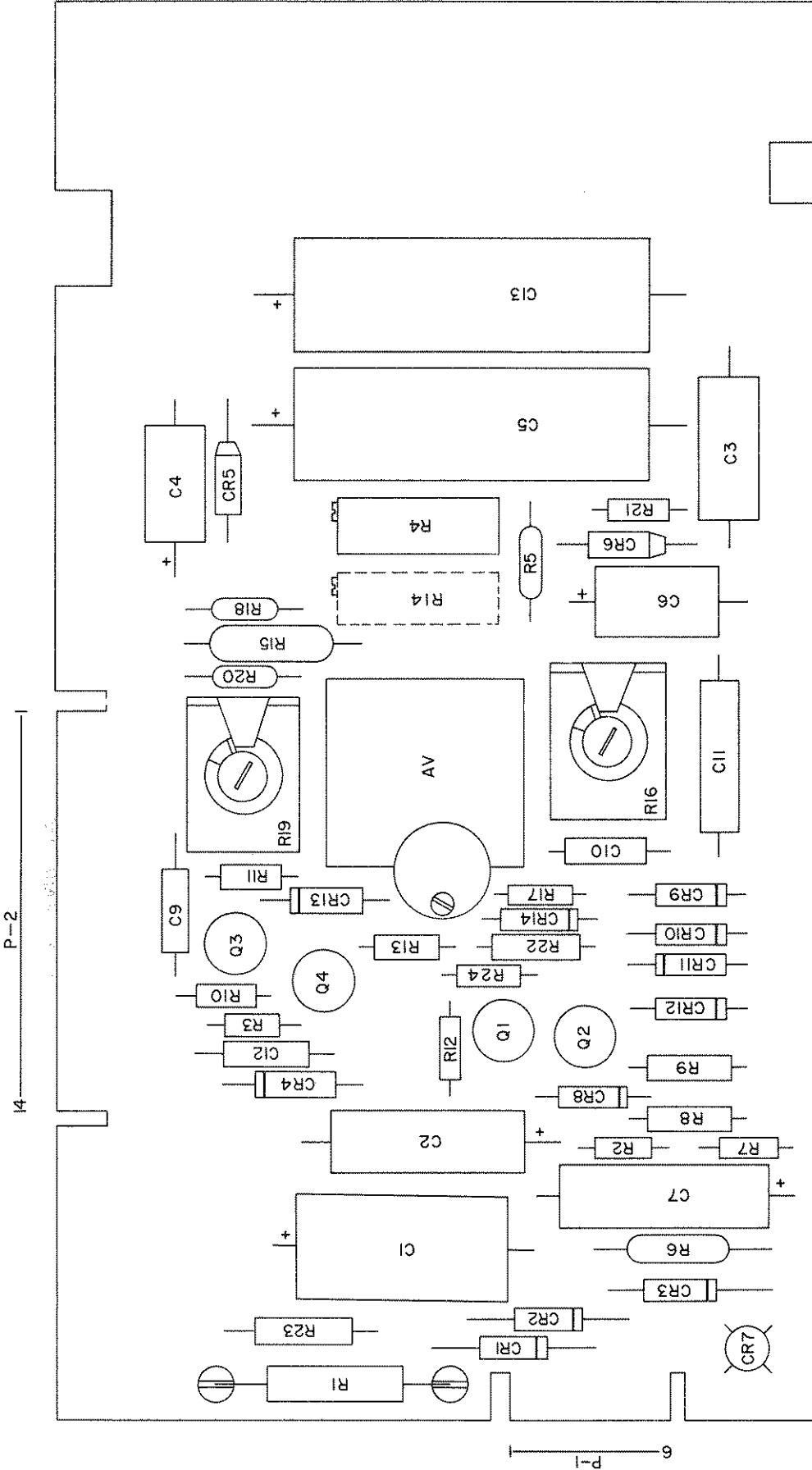

NOTES

1. C10 AND R16 USED ONLY IN MODELS JOE 6-10M AND JOE 15-6M.
2. C12 NOT USED IN JOE 6-10M, JOE 25-4M, JOE 36-3M AND JOE 75-1.5M
3. R22 NOT USED IN JOE 6-10M, JOE 25-4M, AND JOE 36-3M.
4. C13 NOT USED IN JOE100-1M.
5. R14 IS AN OPTIONAL ZERO CONTROL. (MODELS WITH SUFFIX "E").

FIG. 5-5 PRINTED CIRCUIT BOARD, COMPONENT LOCATION

SECTION VI – ELECTRICAL PARTS LIST AND DIAGRAMS

6-1 GENERAL

6-2 This section contains the main schematic, the parts location diagrams, and a list of all replaceable electrical parts. All components are listed in alpha-numerical order of their reference designations. Consult your Kepco Representative for replacement of parts not listed here.

6-3 ORDERING INFORMATION

6-4 To order a replacement part or to inquire about parts not listed in the parts list, address order or inquiry either to your authorized Kepco Sales Representative or to:

KEPCO, INC.
131–38 Sanford Avenue
Flushing, N.Y. 11352

6-5 Specify the following information for each part:

- a) Model and complete serial number of instrument.
- b) Kepco part number.
- c) Circuit reference designator.
- d) Description.

6-6 To order a part not listed in the parts list, give a complete description and include its function and location.

NOTE: KEPCO DOES NOT STOCK OR SELL COMPLETE POWER SUPPLY SUBASSEMBLIES AS DESCRIBED HERE AND ELSEWHERE IN THIS INSTRUCTION MANUAL. SOME OF THE REASONS ARE LISTED BELOW:

- 1) Replacement of a complete subassembly is a comparatively rare necessity.
- 2) Kepco's subassemblies are readily serviceable, since most of them are of the "plug-in" type.
- 3) All active components are socket mounted, making replacement extremely easy.
- 4) The nature of a closed-loop power supply system requires that subassembly replacement is followed by careful measurement of the total power supply performance. In addition, depending on the function of the subassembly, extensive alignment may be required to restore power supply performance to specified values.

IF REPAIRS INVOLVING SUBASSEMBLY REPLACEMENTS ARE REQUIRED, PLEASE CONSULT YOUR LOCAL KEPCO REPRESENTATIVE OR THE KEPCO SALES ENGINEERING DEPARTMENT IN FLUSHING, NEW YORK, N.Y.

ABBREVIATIONS USED IN KEPCO PARTS LISTS

A) Reference Designators:

A	= Assembly	L	= Inductor
B	= Blower (Fan)	LC	= Light-Coupled Device
C	= Capacitor	M	= Meter
CB	= Circuit Breaker	P	= Plug
CR	= Diode	Q	= Transistor
DS	= Device, Signaling (Lamp)	R	= Resistor
F	= Fuse	S	= Switch
FX	= Fuse Holder	T	= Transformer
IC	= Integrated Circuit	TB	= Terminal Block
J	= Jack	V	= Vacuum Tube
K	= Relay	X	= Socket

B) Description Abbreviations

A	= Ampere	DC	= Direct Current
AC	= Alternating Current	DPDT	= Double Pole, Double Throw
AMP	= Amplifier	DPST	= Double Pole, Single Throw
AX	= Axial	ELECT	= Electrolytic
CAP.	= Capacitor	F	= Farad
CER	= Ceramic	FILM	= Polyester Film
CT	= Center-Tap	FLAM	= Flammable
°C	= Degree Centigrade	°F	= Degree Fahrenheit
FXD	= Fixed	RAD	= Radial
Ge	= Germanium	RECT	= Rectifier
H	= Henry	REG	= Regulated
Hz	= Hertz	RECY	= Recovery
IC	= Integrated Circuit	RES	= Resistor
K	= Kilo (10 ³)	RMS	= Root Mean Square
m	= Milli (10 ⁻³)	Si	= Silicone
M	= Mega	S-End	= Single Ended
MFR	= Manufacturer	SPDT	= Single Pole, Double Throw
MET.	= Metal	SPST	= Single Pole, Single Throw
n	= Nano (10 ⁻⁹)	TAN	= Tantalum
NC	= Normally Closed	TSTR	= Transistor
NO	= Normally Open	u	= Micro (u) (10 ⁻⁶)
P	= Pico (10 ⁻¹²)	VAR	= Variable
PC	= Printed Circuit	V	= Volt
POT	= Potentiometer	W	= Watt
PIV	= Peak Inverse Voltage	W.W.	= Wire Wound
p-p	= Peak to Peak		
ppm	= Parts Per Million		
PWR	= Power		



REPLACEMENT PARTS LIST

PRINTED CIRCUIT BOARD ASSEMBLY (A1),MODEL JOE 55-2(M) (E) (T) Code 4-969

SCHEMATIC NO.	QTY.	DESCRIPTION	MFRS. NAME & PART NO. (SEE NOTE)	KEPCO PART NO.
A _v	1	Plug-In Amplifier	Kepeco Inc. 250-0013	250-0013
C1	1	Capacitor,Electrolytic,Pigtail 25 μ F, 150 V	Sprague 38D256F150FE2	117-0639
C2	1	Capacitor,Electrolytic,Pigtal 290 μ F, 12 V	Sprague 30D297G012DF2	117-0647
C3	1	Capacitor,Mylar,Pigtail 0.5 μ F, 200 V	Wesco 32MM	117-0575
C4,6	2	Capacitor,Electrolytic,Pigtail 150 μ F, 3 V	General Electric 76F02BF151	117-0512
C5,13	2	Capacitor,Electrolytic,Pigtail 110 μ F, 100 V	Sprague 38D117F100FL2	117-0612
C7	1	Capacitor,Electrolytic,Pigtail 75 μ F, 50 V	Sprague 30D756G050DF2	117-0646
C9	1	Capacitor,Mylar,Pigtail 0.01 μ F, 200 V	Sprague 192P10302	117-0353
C11	1	Capacitor,Mylar,Pigtail 0.1 μ F, 600 V	TRW X663F	117-0316
C12	1	Capacitor,Mylar,Pigtail 560 pF, 200 V	Sprague 192P56192	117-0569
CR1,2	2	Rectifier,Silicon	Semicon SM-140	124-0028
CR3,4,13, 14	4	Rectifier,Silicon,Pigtail	Semicon SM-110	124-0133
CR5,6	2	Rectifier,Silicon,Pigtail	Solitron 124-0178	124-0178
CR7	1	Rectifier,Silicon,Bridge,Pigtail	Varo EBR-W102	124-0346
CR8,9,10, 11,12	5	Zener Diode	Transitron SV125	121-0028
Q1,2	2	Transistor,Silicon,NPN	M.S.Transistor 119-0094	119-0094
Q3,4	2	Transistor,Silicon,NPN	General Electric 2N336A	119-0056
R1	1	Resistor,Fixed,Power,Axial 12 K ohm, 3 W, 5%	Tepro TS-3W	115-2194
R2	1	Resistor,Fixed,Molded 27 ohm, 1/4 W, 10%	IRC GBT 1/4	115-2317
R3	1	Resistor,Fixed,Molded 560 ohm, 1/4 W, 10%	IRC GBT 1/4	115-2210
R4	1	Resistor,Variable,WW 1 K ohm, 0.5 W, 10%	Bourns 3067S-1-102	115-0739
R5	1	Resistor,Fixed,Precision,WW 5.7 K ohm, 1 W, 1%	Tepro TS-1W	115-1301
R6	1	Resistor,Fixed,Precision,M.F. 232 ohm, 1 W, 1%	IRC CES Type	115-1953
R7	1	Resistor,Fixed,M.G. 82 K ohm, 1/4 W, 5%	IRC RG 1/4	115-2012

NOTE:

REPLACEMENT PARTS MAY BE ORDERED FROM KEPCO, INC. ORDERS SHOULD INCLUDE KEPCO PART NUMBER AND DESCRIPTION.

PLEASE NOTE: THE MANUFACTURER'S NAME AND PART NUMBER LISTED FOR EACH ITEM ON REPLACEMENT PARTS LISTS, REPRESENTS AT LEAST ONE SOURCE FOR THAT ITEM AND IS LISTED SOLELY FOR THE CONVENIENCE OF KEPCO EQUIPMENT OWNERS IN OBTAINING REPLACEMENT PARTS LOCALLY. WE RESERVE THE RIGHT TO USE EQUIVALENT ITEMS FROM ALTERNATE SOURCES. KEPCO, INC.

www.valuetronics.com



REPLACEMENT PARTS LIST

PRINTED CIRCUIT BOARD ASSEMBLY (A1),MODEL JOE 55-2(M)(E) (T) Code 4-1769

SCHEMATIC NO.	QTY.	DESCRIPTION	MFRS. NAME & PART NO. (SEE NOTE)	KEPCO PART NO.
R8	1	Resistor,Fixed,Molded 3.9 K ohm, 1/2 W, 5%	Allen Bradley EB3925	115-0808
R9	1	Resistor,Fixed,Molded 1 K ohm, 1/2 W, 5%	Allen Bradley EB1025	115-0340
R10	1	Resistor,Fixed,M.G. 510 ohm, 1/4 W, 5%	IRC RG 1/4	115-2274
R11	1	Resistor,Fixed,Molded 47 K ohm, 1/4 W, 10%	IRC GBT 1/4	115-2237
R12	1	Resistor,Fixed,M.G. 6.2 K ohm, 1/4 W, 5%	IRC RG 1/4	115-2258
R13	1	Resistor,Fixed,Molded 12 K ohm, 1/4 W, 10%	IRC GBT 1/4	115-2276
*R14	1	Resistor,Variable,Cermet 100 K ohm, 3/4 W, 20%	Helipot 78PR100K	115-2044
R15	1	Resistor,Fixed,Precision,M.F. 499 K ohm, 1/4 W, 1%	IRC CEA Type	115-2309
*R15	1	Resistor,Fixed,Molded 10 ohm, 1/2 W, 10%	Allen Bradley EB1001	115-0502
R17	1	Resistor,Fixed,Molded 1.5 K ohm, 1/4 W, 10%	IRC GBT 1/4	115-2229
R18	1	Resistor,Fixed,Precision,M.F. 750 ohm, 1/4 W, 1%	IRC CEA Type	115-2259
R19	1	Resistor,Variable,Composition 20 K ohm, 1/4 W, 30%	C.R.L. Type 71-1	115-2189
R20	1	Resistor,Fixed,Precision,M.F. 10 K ohm, 1/4 W, 1%	IRC CEA Type	115-2174
R21	1	Resistor,Fixed,Molded 10 ohm, 1/4 W, 10%	IRC GBT 1/4	115-2230
R22	1	Resistor,Fixed,M.G. 36 K ohm, 1/4 W, 5%	IRC RG 1/4	115-2224
R23	1	Resistor,Fixed,Molded 12 K ohm, 1 W, 10%	Allen Bradley GB1221	115-0090
R24	1	Resistor,Fixed,M.G. 750 ohm, 1/4 W, 5%	IRC RG 1/4	115-2352

*On Models with Suffix "E" Only.

NOTE:

REPLACEMENT PARTS MAY BE ORDERED FROM KEPCO, INC. ORDERS SHOULD INCLUDE KEPCO PART NUMBER AND DESCRIPTION.

PLEASE NOTE: THE MANUFACTURER'S NAME AND PART NUMBER LISTED FOR EACH ITEM ON REPLACEMENT PARTS LISTS, REPRESENTS AT LEAST ONE SOURCE FOR THAT ITEM AND IS LISTED SOLELY FOR THE CONVENIENCE OF KEPCO EQUIPMENT OWNERS IN OBTAINING REPLACEMENT PARTS LOCALLY. WE RESERVE THE RIGHT TO USE EQUIVALENT ITEMS FROM ALTERNATE SOURCES. KEPCO, INC.
--

10/10/2017

10/10/2017

10/10/2017

10/10/2017

10/10/2017



REPLACEMENT PARTS LIST

MAIN CHASSIS ASSEMBLY (A2),MODEL JOE 55-2(M)(E) (T)

Code 4-969

SCHEMATIC NO.	QTY.	DESCRIPTION	MFRS. NAME & PART NO. (SEE NOTE)	KEPCO PART NO.
---------------	------	-------------	-------------------------------------	----------------

FRONT PANEL ASSEMBLY CONTAINS:

DS101	1	Pilot Light Assembly	Industrial Devices 2100 Series	152-0087
CR101	1	Rectifier,Silicon,Pigtail	Semicon SM-140	124-0028
*M101	1	Meter 0-2 Amp.	Honeywell Model 504	135-0421
*M102	1	Meter 0-60 Volt	Honeywell Model 504	135-0408
R101	1	Resistor,Variable,Composition 5 K ohm, 1/2 W	C.T.S. VA-45	115-2277
R102	1	Resistor,Variable,WW 60 K ohm, 2 W, 5%	Bourns 3507S1-603	115-2181
*S102,103	2	Switch	Stackpole SS-72-1	127-0254

*Metered Models Only.

B201	1	Motor	Howard Industries 21075	148-0026
C201	1	Capacitor,Electrolytic,Pigtail 5.2 K μ F, 100 V	General Electric 86F1133MA	117-0636
CR201	1	Zener Diode	International Rect. 1N821	121-0041
*CR201	1	Zener Diode	IRC 1N827	121-0062
F201	1	Fuse,Slow Blow 2.5 A	Buss MDL-2 1/2	141-0029
R201	1	Resistor,Fixed,Molded 4.7 K ohm, 2 W, 10%	Allen Bradley HB4721	115-0056
R202	1	Resistor,Fixed,Power,Strip 1.5 K ohm, 20 W, 5%	Hardwick Hindle 2BRS-56-1.5K	115-0923
S201	1	Switch	Stackpole RS47-FB	127-0230
T201	1	Transformer	Kepeco Magnetics	100-1761

*On Models with Suffix "T" Only.

NOTE:

REPLACEMENT PARTS MAY BE ORDERED FROM KEPCO, INC. ORDERS SHOULD INCLUDE KEPCO PART NUMBER AND DESCRIPTION.

PLEASE NOTE: THE MANUFACTURER'S NAME AND PART NUMBER LISTED FOR EACH ITEM ON REPLACEMENT PARTS LISTS, REPRESENTS AT LEAST ONE SOURCE FOR THAT ITEM AND IS LISTED SOLELY FOR THE CONVENIENCE OF KEPCO EQUIPMENT OWNERS IN OBTAINING REPLACEMENT PARTS LOCALLY. WE RESERVE THE RIGHT TO USE EQUIVALENT ITEMS FROM ALTERNATE SOURCES. KEPCO, INC.

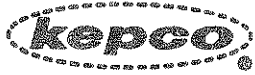

REPLACEMENT PARTS LIST

HEATSINK ASSEMBLY (A3),MODEL JOE 55-2(M) (E) (T)

Code 4-969

SCHMATIC NO.	QTY.	DESCRIPTION	MFRS. NAME & PART NO. (SEE NOTE)	KEPCO PART NO.
CR301,302	2	Rectifier,Silicon	Semicon S-5A4	124-0348
Q301,302	4	Transistor,NPN	Solitron	119-0088
303,304			93SE128	
Q305	1	Transistor,NPN	RCA 2N3441	119-0071
R301,302, 303,304	4	Resistor,Fixed,Power,Axial 1 ohm, 3 W, 3%	Tepro TS3WIN	115-2218
R305	1	Resistor,Fixed,Molded 47 ohm, 1/4 W, 10%	IRC GBT 1/4	115-2273
R306	1	Resistor,Fixed,Molded 390 ohm, 1/4 W, 10%	IRC GBT 1/4	115-2234
R307	1	Resistor,Fixed,Precision 0.5 ohm, 5 W, 1%	Tepro TSK-5W	115-2198

NOTE:

REPLACEMENT PARTS MAY BE ORDERED FROM KEPCO, INC. ORDERS SHOULD INCLUDE KEPCO PART NUMBER AND DESCRIPTION.

PLEASE NOTE: THE MANUFACTURER'S NAME AND PART NUMBER LISTED FOR EACH ITEM ON REPLACEMENT PARTS LISTS, REPRESENTS AT LEAST ONE SOURCE FOR THAT ITEM AND IS LISTED SOLELY FOR THE CONVENIENCE OF KEPCO EQUIPMENT OWNERS IN OBTAINING REPLACEMENT PARTS LOCALLY. WE RESERVE THE RIGHT TO USE EQUIVALENT ITEMS FROM ALTERNATE SOURCES.	KEPCO, INC.
--	-------------

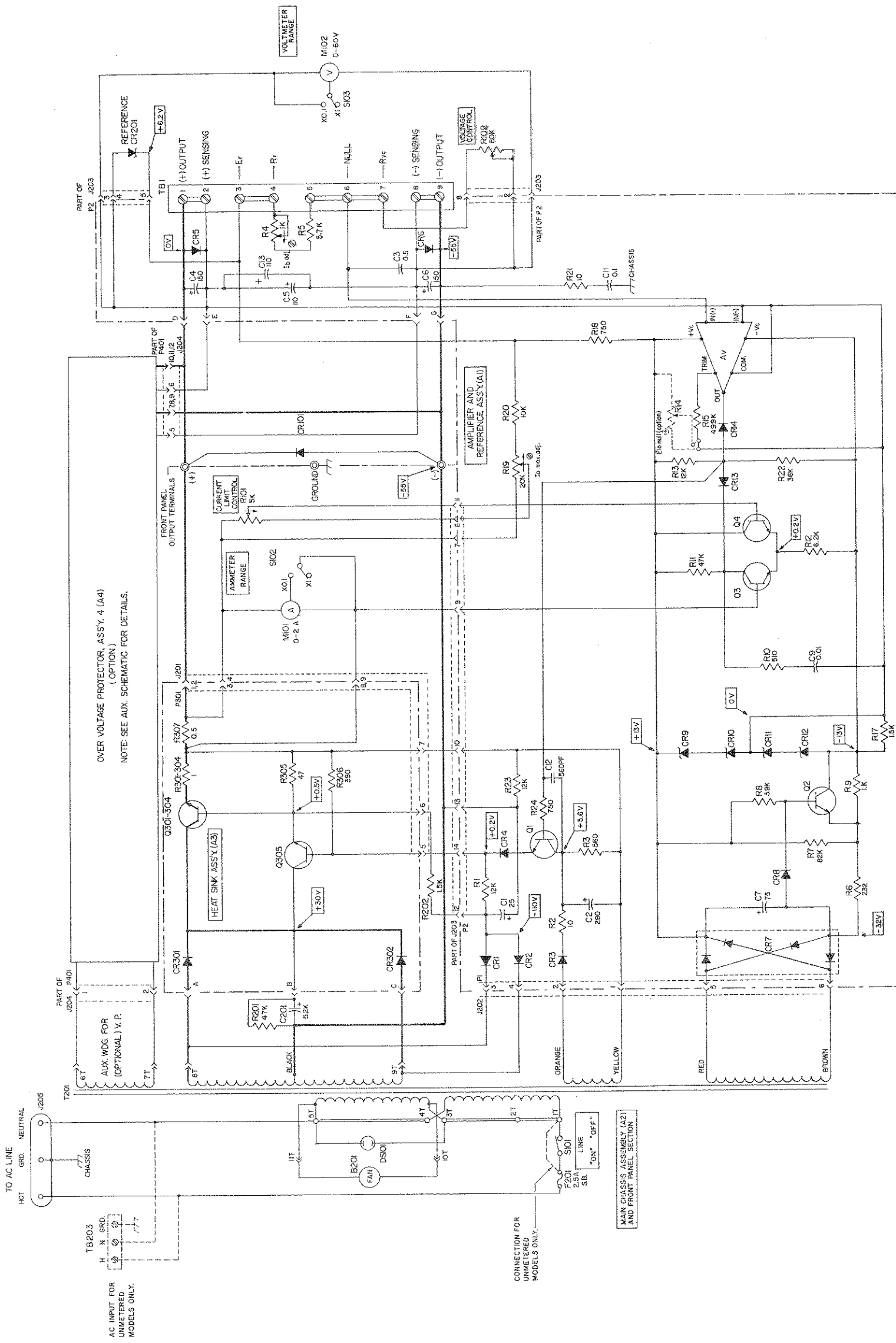

- NOTES:
1. RESISTOR VALUES IN OHMS, K=1000
 2. CAPACITOR VALUES IN MICROFARADS, UNLESS INDICATED OTHERWISE.
 3. CONNECTORS MARKED WITH CAPITAL LETTERS ARE "QUICK-DISCONNECT" TERMINALS. CONNECTORS SUFFIXED "T" ARE TRANSFORMER TERMINALS.
 4. POLARIZED COMPONENTS UNDER THE FOLLOWING HEADINGS:
 - A1 LINE AT 15V AC, 500 MA MAX. RATED, 10+0.
 - B1 METERS 20K OHM /VOLT
 - C1 ALL VALUES WITH REFERENCE TO THE POSITIVE (+) SENSING TERMINAL, EXCEPT IN THE OVERVOLTAGE CIRCUIT, WHERE THE VOLTAGES ARE WITH RESPECT TO THE NEGATIVE (-) SENSING TERMINAL.
 5. M101, M102, S101, S102, S103, D101 AND FRONT PANEL OUTPUT TERMINALS USED IN METERED MODELS (SUFFIX "M") ONLY.

FIG. 6-1 MAIN SCHEMATIC, MODEL JOE 55-2M

Data subject to change without notice.
 PATENT NOTICE: Applicable Patent Nos. © will be supplied on request.



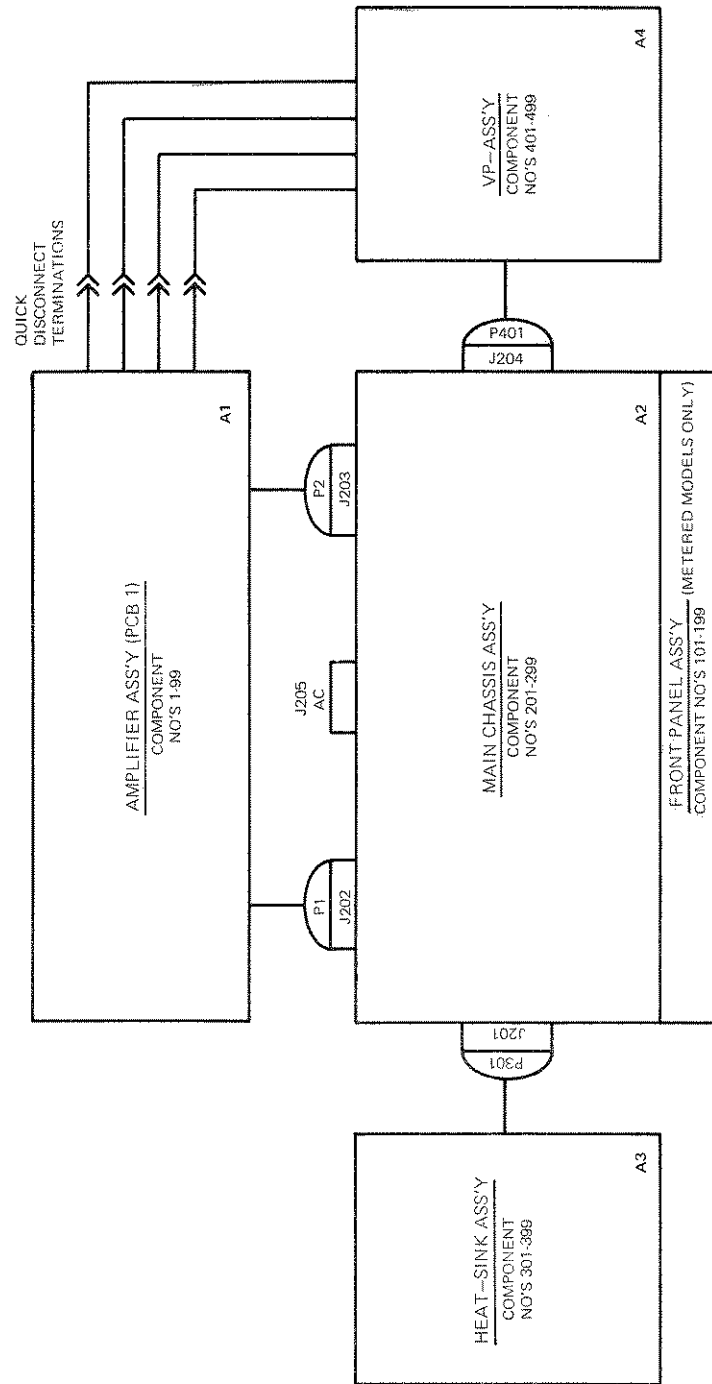

FIG. 6-2 PLUG-IN DIAGRAM

Please note the following corrections to the Manual Material as indicated :

Parts List and Schematic Diagram:

1. CHANGE:	R2	Resistor, Fixed, Molded	27 ohm, 10%, 1/4W	Kepeco P/N 115-2317
TO:	R2	Resistor, Fixed, Molded	10 ohm, 10%, 1/4W	Kepeco P/N 115-2230
2. CHANGE:	C201	Capacitor, Electrolytic, Can	5.2KuF, 100V	Kepeco P/N 117-0636
TO:	C201	Capacitor, Electrolytic, Can	5200uF, 100V	Kepeco P/N 117-0730
3. CHANGE:	R411	Resistor, Fixed, Precision, M.F.	10K ohm, 1%, 1/4W	Kepeco P/N 115-2174
TO:	R411	Resistor, Fixed, Precision, M. F.	8.06K ohm, 1%, 1/4W	Kepeco P/N 115-2445

Note: Models with suffix "VP" only

4. DELETE:	R22	Resistor, Fixed, M. G.	36K ohm, 5%, 1/4W	Kepeco P/N 115-2224
5. CHANGE:	Q301,4	Transistor, Silicon, NPN		Kepeco P/N 119-0088
TO:	Q301,4	Transistor, Silicon, NPN		Kepeco P/N 119-0070
6. CHANGE:	Q2	Transistor, Silicon, NPN		Kepeco P/N 119-0094
TO:	Q2	Transistor, Silicon, NPN		Kepeco P/N 119-0059
7. DELETE:	R9	Resistor, Fixed, Molded	1K ohm, 5%, 1/2W	Kepeco P/N 115-0340
8. CHANGE:	Q3,4	Transistor, Silicon, NPN		Kepeco P/N 119-0056
TO:	Q3,4	Transistor, Silicon, NPN		Kepeco P/N 119-0093
9. ADD:	C14	Capacitor, Ceramic, Disc.	0.005uF, 500V	Kepeco P/N 117-0061

Note: C14 has been added to Assembly A1. It is connected between the collector and the emitter of Q2.

10. ADD:	RC101	RC Network , 0.1uF/100 ohm		Kepeco P/N 245-0003
----------	-------	----------------------------	--	---------------------

Note: RC101 has been added to the front panel assembly. It is connected across the contacts of S101.

11. CHANGE:	R10	Resistor, Fixed, Metal Glaze	510 ohm, 5%, 1/2W	Kepeco P/N 115-2274
TO:	R10	Resistor, Fixed, Metal Glaze	511 ohm, 1%, 1/2W	Kepeco P/N 115-2092

JQE 55-2(M)/10-1569/r4	C2289
JQE 55-2(M)/6-2470/r5	C2419
JQE 55-2(M)(VP)/8-1770/r5	BMC
JQE 55-2(M)(VP)/6-1571/r6	C2658
JQE 55-2(M)(VP)/8-971/r7	C2698
JQE 55-2(M)/3-1072/r8	C2842
JQE 55-2(M)(VP)/8-2272/r8	C2948
JQE 55-2(M)/8-2272/r9	C2947
JQE 55-2(M)(VP)/7-676/r9	C3603
JQE 55-2(M)/7-676/r10	C3596
JQE 55-2(M)(VP)/12-2277/r10	C3826
JQE 55-2(M)/12-2277/r11	C3825

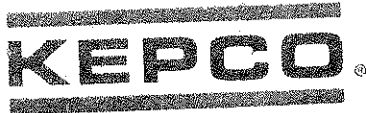

Please note the following corrections to the Manual Material as indicated :

Parts List and Schematic Diagram:

12. ADD: C18 Capacitor, Ceramic, Disc. 500pF, 10%, 500V Kepco P/N 117-0755

Note: C18 has been added to Assembly A1. It is connected between base and collector of Q4.

13. CHANGE: R4 Resistor, Variable, W. W. 1K ohm, 10%, 1/2W Kepco P/N 115-0739
TO: R4 Resistor, Variable, W. W. 1K ohm, 5%, 1W Kepco P/N 115-2343

Note: The "E" OPTION (E_{10} NULL OR ZERO ADJUST) is now a standard feature on all JQE models.

JQE 55-2(M)(VP)/6-1278/r11
JQE 55-2(M)/6-1278/r12
JQE 55-2(M)(VP)/9-978/r12
JQE 55-2(M)/9-978/r13
JQE 55-2(M)(VP)/5-179/r13
JQE 55-2(M)/5-179/r14

C3960
C3958
C4053
C4046
C4321
C4320

