

KEPCO

POWER SUPPLIES

BOP
HIGH VOLTAGE

Please record the equipment nameplate
serial number in the space provided.

Model BOP 1000M

Serial No.

instruction manual

The KEPCO equipment described in this instruction manual is of proprietary design, and is licensed under the United States patent rights of Forbro Design Corp.

The contents of this instruction manual are copyrighted. Reproduction of any part may only be made with the specific written permission of KEPCO, Inc. Data subject to change without notice.



KEPCO®

©1975, Kepco, Inc.

TABLE OF CONTENTS

PARAGRAPH		PAGE
SECTION I – INTRODUCTION		
1-1	Scope of Manual	1-1
1-3	General Description	1-1
1-6	Electrical Specifications, General	1-1
1-7	Electrical Specifications, Performance	1-1
1-8	Miscellaneous Features	1-4
1-9	Mechanical Specifications	1-5
SECTION II – INSTALLATION		
2-1	Unpacking and Inspection	2-1
2-3	Terminations	2-1
2-4	A-C Power Input Requirements	2-3
2-6	Cooling	2-4
2-8	Preliminary Check-out	2-4
2-10	Installation	2-4
SECTION III – OPERATION		
3-1	Introduction	3-1
3-5	BOP Operation with Local (Front Panel) Output Control	3-5
3-6	Voltage Mode Operation with Current Limiting	3-5
3-8	Current Mode Operation with Voltage Limiting	3-6
3-10	BOP Operation with Remote Control of the Voltage Control Channel	3-6
3-11	Remote D-C Output Voltage Control by Resistance	3-6
3-17	Remote D-C Voltage Control by Means of a D-C Signal Voltage	3-7
3-22	The BOP as an Amplifier	3-9
3-28	BOP Operation with Remote Control of the Current Control Channel	3-12
3-31	Remote Control of the BOP Current Limit	3-16
3-34	Remote Control of the BOP Voltage Limit	3-17
SECTION IV – THEORY OF OPERATION		
4-1	General	4-1
4-3	Simplified Diagram Analysis	4-1
4-13	The Meaning of the PRE-AMPLIFIER Offset Specifications	4-3
4-16	BOP Circuit Description	4-4
4-19	A-C Input Circuit	4-4
4-23	Main D-C Supplies and Output Stage with Driver	4-5
4-26	The Reference and Auxilliary Power Supplies	4-5
4-28	The Voltage and Current Control Channels	4-6
4-30	The Voltage and Current Limit Circuits	4-6
4-34	The Indicator Light and Flag Signal Circuits	4-7/4-8
4-37	The Metering and Compensating Circuits	4-7/4-8
SECTION V – MAINTENANCE		
5-1	General	5-1
5-3	Disassembly	5-1
5-5	Periodic Maintenance	5-2
5-7	Internal Adjustments and Calibrations	5-2
5-9	Troubleshooting	5-2
5-11	Trouble Analysis	5-2

SECTION V – MAINTENANCE (cont'd)

5-19	Operational Power Supply Performance Measurements	5-7
5-21	Required Instrumentation	5-7
5-22	Output Effect Measurements, Voltage Control Channel	5-8
5-24	Output Effect Measurements, Current Control Channel	5-9
5-26	Dynamic Measurements	5-10

SECTION VI – PARTS LIST AND DIAGRAMS

6-1	General	6-1/6-2
6-3	Ordering Information	6-1/6-2

LIST OF ILLUSTRATIONS

FIGURE		PAGE
1-1	BOP (H.V.) Operational Power Supply, Front View	iv
1-2	BOP (H.V.) Operational Power Supply, Rear View	iv
1-3	BOP Output Characteristic	1-4
1-4	BOP Output Waveform with Phase Shift	1-4
1-5	Mechanical Outline Drawing, BOP–H.V.	1-6
2-1	Location of Internal Calibration Controls	2-1
2-2	BOP Terminations and Controls	2-2
2-3	A-C Source Voltage Selector, Location	2-3
2-4	Rack Installation of the BOP	2-5
3-1A	BOP Voltage Control Channel (Simplified Diagram)	3-2
3-1B	BOP Current Control Channel (Simplified Diagram)	3-2
3-1C	BOP (\pm) Voltage Limit Circuit (Simplified Diagram)	3-3
3-1D	BOP (\pm) Current Limit Circuit (Simplified Diagram)	3-3
3-2	Basic 2-wire Load Connection and Grounding	3-4
3-3	Load Connections with Error Sensing and Grounding	3-4
3-4	Remote Potentiometer Control of the BOP D-C Output Voltage	3-6
3-5	Remote Two-Terminal Resistance Control of the BOP D-C Output Voltage	3-7
3-6	Digital Control of the BOP D-C Output Voltage	3-8
3-7	BOP D-C Output Voltage Control with a High Impedance Signal Source	3-8
3-8	Graphs of Possible BOP INPUT/OUTPUT Wave Shapes	3-10
3-9	Basic Programming Circuit for Use of the BOP as a Bipolar Amplifier (Voltage Mode)	3-11
3-10	Programming Circuit for Driving the BOP Output Voltage with a Bipolar Signal	3-11
3-11	Programming Circuit for Driving the BOP Output Voltage with a High Impedance Source using the Non-Inverting Input of the Pre-Amplifier	3-12
3-12	Local (Front Panel) Control of the BOP Output Current with the BIPOLAR Current Control	3-12
3-13	Remote Potentiometer Control of the BOP Output Current	3-13
3-14	Remote Output Current Control by Means of a Two-Terminal Resistance	3-13
3-15	Digital Control of the BOP Output Current	3-14
3-16	BOP Output Current Control with a High Impedance Signal Source	3-14
3-17	Basic Programming Circuit for Use of the BOP as a Bipolar Current Stabilized Amplifier	3-15
3-18	Programming Circuit for Driving the BOP Output Current with a Bipolar Signal	3-15
3-19	Programming Circuit for Driving the BOP Output Current with a High Impedance Source	3-16
3-20	Local (Front Panel) Control of the BOP Current Limit Circuit	3-16
3-21	Symmetrical Remote Control of the BOP Current Limits	3-17

LIST OF ILLUSTRATIONS (cont'd)

FIGURE		PAGE
3-22	Independent Remote Control of the BOP (+) I_O and (-) I_O Limit	3-17
3-23	Local (Front Panel) Control of the BOP Voltage Limit	3-18
3-24	Symmetrical Control of the BOP Voltage Limits	3-18
3-25	Independent Remote Control of the BOP (+) E_O and (-) E_O Voltage Limit Circuits	3-19/3-20
4-1	Bipolar Output Stage (Simplified Diagram), BOP	4-1
4-2	Dual OR-GATE, (Simplified Diagram), BOP	4-2
4-3	Main D-C Supplies and Output Stage (Simplified Diagram), BOP	4-5
4-4	BOP Current Stabilization Compensation Circuit	4-7/4-8
4-5	Simplified Schematic Diagram, BOP	4-9/4-10
5-1	Cover Removal and PC Board Disassembly, BOP	5-1
5-2	Trouble Shooting Flow-Chart	5-5/5-6
5-3	Output Effect Measurements, Voltage Control Channel	5-8
5-4	Output Effect Measurements, Current Control Channel	5-9
5-5	Measurement of the Programming Time Constant	5-10
6-1	Plug-in Diagram, BOP-H.V.	6-17/6-18
6-2	Component Location, Main Chassis and Front Panel Assembly (A2)	6-19/6-20
6-3	Component Location, Assemblies A4 and A5	6-23/6-24
6-5	Main Schematic Diagram	6-25/6-26

LIST OF TABLES

TABLE		PAGE
1-1	Output Ranges and Impedances	1-2
1-2	Output Effects, Offsets and Reference Specifications	1-2
1-2	Dynamic Specifications	1-3
2-1	Internal Calibration Controls	2-1
2-2	BOP Terminations and Controls	2-3

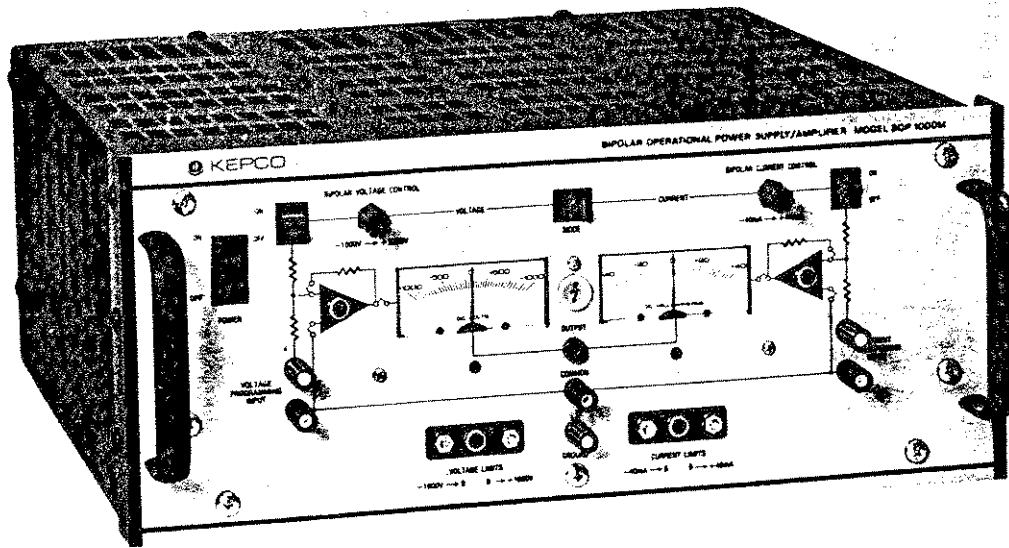

FIG. 1-1 BOP (H.V.) OPERATIONAL POWER SUPPLY, FRONT VIEW.

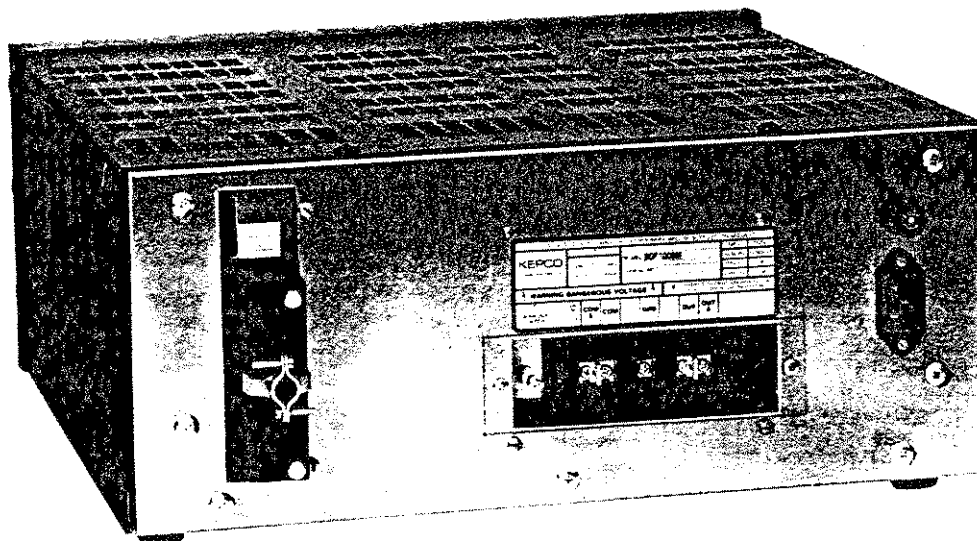

FIG. 1-2 BOP (H.V.) OPERATIONAL POWER SUPPLY, REAR VIEW

SECTION I – INTRODUCTION

1-1 SCOPE OF MANUAL

- 1-2 This manual contains instructions for the installation, operation and maintenance for the Models BOP 500M and BOP 1000M Bipolar Operational Power Supplies, manufactured by Kepco Inc., Flushing, New York, U.S.A.

1-3 GENERAL DESCRIPTION

- 1-4 The Kepco Model BOP 500M and BOP 1000M are high voltage power sources, which combine the capabilities of fast programmable power supplies with a Class A output stage, which can respond bidirectionally from zero. The "BOP" can be operated in a "Voltage Stabilizing" or "Current Stabilizing" operating mode (selectable by a front panel switch). The BOP incorporates two separate control channels, for local (front panel) or remote control of the output current and the output voltage. In addition, bounding currents for bipolar voltage and current limiting are provided which may be adjusted manually (by front panel controls) or can be remotely programmed. All control and bounding channels are connected to the bipolar (Class A) output stage via an "EXCLUSIVE-OR" gate, so that only one circuit is in control of the BOP output at any one time. Some applications are listed below:
- A) VOLTAGE MODE OPERATION. (Current limiting either front panel adjusted or remotely programmed using the current limiting channel).
 - 1) High speed, bipolar d-c voltage source (remote or locally controlled output).
 - 2) Scaling or summing amplifier with or without d-c bias.
 - B) CURRENT MODE OPERATION (Voltage limiting either front panel adjusted or remotely programmed using the voltage limiting channel).
 - 1) High speed, bipolar d-c current source (remotely or locally controlled output).
 - 2) Amplification of a-c currents, with or without d-c biasing.
- 1-5 The main chassis of the Model BOP Operational Power Supply/Amplifier is constructed of plated steel. The wrap-around cover is perforated steel, plated and painted in a dark gray texture. The front panel material is aluminum, treated and painted light gray (Color 26440 per Fed. Std. 595). The major part of the circuitry is located on plug-in type circuit boards for convenient access.

1-6 ELECTRICAL SPECIFICATIONS, GENERAL

- A) INPUT SOURCE REQUIREMENTS: 105 to 125 V a-c or 210 to 250 V a-c, 50 to 65 Hz, selectable by the SOURCE VOLTAGE SELECTOR SWITCH (refer to Section II, FIG. 2-3). A built-in time delay circuit holds the BOP output at zero for approximately 30 seconds after a-c power is turned on. Power consumption approximately 250 Watts. Power factor: 0.8. The primary circuit is protected by a fuse.
- B) OPERATING TEMPERATURE RANGE: -20°C to $+65^{\circ}\text{C}$.
- C) STORAGE TEMPERATURE RANGE: -40°C to $+85^{\circ}\text{C}$.
- D) COOLING: By natural convection.
- E) ISOLATION FROM GROUND: The BOP circuitry, its output and programming terminals have no d-c connection to the chassis. The COMMON terminal of the BOP can be operated up to 500 volts (d-c or peak) off a-c ground. The common mode current (leakage from output to ground) is less than $50\ \mu\text{A}$ (rms) or 5 mA (p-p) at 115V a-c power input, 60 Hz.

1-7 ELECTRICAL SPECIFICATIONS, PERFORMANCE

- A) OUTPUT RANGES: See Table 1-1.
- B) OUTPUT IMPEDANCE: See Table 1-1.

MODEL	d-c OUTPUT RANGE		OUTPUT IMPEDANCE	
	VOLTS	mA	VOLTAGE MODE	CURRENT MODE
BOP 500M	-500 to +500	-80 to +80	d-c OHMS + SERIES L 0.05Ω + 10 mH	d-c OHMS + SHUNT C 100 MΩ + 0.02 μF
BOP 1000M	-1000 to +1000	-40 to +40	0.2Ω + 10 mH	400 MΩ + 0.01 μF

TABLE 1-1 OUTPUT RANGES AND IMPEDANCES

C) OUTPUT EFFECTS: See Table 1-2.

INFLUENCE QUANTITY	OUTPUT EFFECTS ⁽¹⁾		PRE-AMPLIFIER OFFSETS		REFERENCES
	VOLTAGE MODE	CURRENT MODE	ΔE_{io}	ΔI_{io}	
SOURCE: 105-125/210-250V a-c	<0.0005%	<0.0005% ⁽⁵⁾	<5 μV	<1 nA	<0.0005%
LOAD: No load - full load	<0.0005%	<0.005%	-	-	<0.0005%
TIME: 8-hour [drift]	<0.01%	<0.01%	<20 μV	<1 nA	<0.005%
TEMPERATURE: Per °C UNPROGRAMMED	<0.01%	<0.01%	<20 μV	<1 nA	<0.005%
OUTPUT DEVIATION: ⁽²⁾ (Ripple and Noise)	rms <10 mV	<25 μA ⁽⁴⁾	-	-	<10 μV
	p-p <200 mV ⁽³⁾	<500 μA ⁽⁴⁾	-	-	<100 μV

⁽¹⁾ Specifications are expressed as a *percent-of-setting* for the output range 10% to 100%. Below 10% output, the specification limit is the rated percentage of the 10% output setting.

⁽²⁾ Common terminal grounded so that the common-mode current does not flow through the load.

⁽³⁾ 20 Hz to 10 MHz.

⁽⁴⁾ For frequency components in the bandwidth of the current stabilizer. Beyond cutoff, noise will appear as a voltage component equal to the rated voltage mode noise.

⁽⁵⁾ Or 0.2 μA, whichever is greater.

TABLE 1-2 OUTPUT EFFECTS, OFFSETS AND REFERENCE SPECIFICATIONS

NOTE: In this instruction manual, Kepco will follow the NEMA standards for d-c Power Supplies and speak of the "Output Effects," caused by changes in the "Influence Quantities." The "Output Effects" are specified either as a percentage change, referred to the maximum specified output voltage (E_o) or current (I_o), or as an absolute change (ΔE_o , ΔI_o), directly in millivolts or milliamperes or both. The illustration below will clarify the NEMA terms.

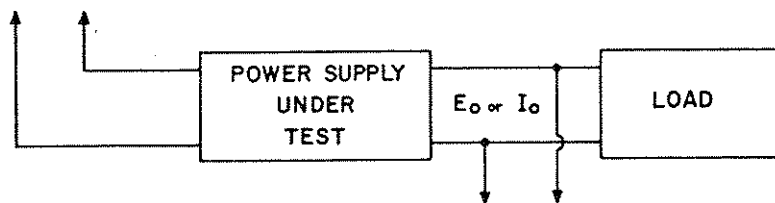

INFLUENCE QUANTITIES

- 1) SOURCE
- 2) LOAD
- 3) TEMPERATURE
- 4) TIME

- | | | |
|-----------------------|----------------------------------|--|
| 1) DUE TO SOURCE | = SOURCE EFFECT | (formerly LINE REGULATION) |
| 2) DUE TO LOAD | = LOAD EFFECT | (formerly LOAD REGULATION) |
| 3) DUE TO TEMPERATURE | = TEMPERATURE EFFECT COEFFICIENT | ... (formerly TEMPERATURE COEFFICIENT) |
| 4) DUE TO TIME | = DRIFT | (formerly STABILITY) |

D) The BOP *output effects*, in response to the tabulated variations in the INFLUENCE QUANTITIES, are given in Table 1-2 for the built-in input and feedback resistor values of the voltage and current channel preamplifiers. The tabulated OFFSET values (see Table 1-2) may be used to calculate the BOP *output effects* if the BOP voltage or current channel is remotely programmed and different values for the feedback resistors (R_f) and the input resistors (R_i) are used. In this case, the tabulated preamplifier offsets and the values of the feedback and input resistors are combined in an "Error Equation", which represents the "Worst Case" output effect for the application at hand:

VOLTAGE MODE: $\Delta E_O = G [\pm \Delta E_{iO} (1 + R_f/R_i) \pm \Delta I_{iO} R_f \pm \Delta E_{ref}]$

CURRENT MODE: $\Delta I_O = \frac{1}{R_S} [\pm \Delta E_{iO} (1 + R_f/R_i) \pm \Delta I_{iO} R_f \pm \Delta E_{ref}]$

R_S = Current Sensing Resistor (BOP 500M = 125 Ω , BOP 1000M = 250 Ω)

ΔI_O = Total Output Current Change

G = Closed Loop Gain (BOP 500M = 50, BOP 1000M = 100)

where: ΔE_O = Total Output Voltage Change
 ΔE_{ref} = Change in the Voltage Reference
 ΔE_{iO} = Change in Offset Voltage
 ΔI_{iO} = Change in Offset Current
 R_f = External Feedback Resistor
 R_i = External Input Resistor

NOTE: Variations in the value of the feedback and input resistors are considered secondary effects in the Error Equation.

See Section IV of this manual for the derivation of the Error Equation.

- E) DYNAMICS: The dynamic response of the BOP output are tabulated in Table 1-3 in both the time domain (Output response to a step program) and in the frequency domain (bandwidth) for large and small signals.

DYNAMIC SPECIFICATION	VOLTAGE CHANNEL		CURRENT CHANNEL	
	BOP 500M	BOP 1000M	BOP 500M	BOP 1000M
Closed Loop Gain:	50 V/V	100 V/V	8 mA/V	4 mA/V
Unity Gain Crossover Frequency:	150 KHz	100 KHz	300 KHz	200 KHz
Bandwidth [d-c to f-3 dB]:	2 KHz	1 KHz	1.3 KHz ⁽¹⁾	0.64 KHz ⁽¹⁾
Programming Time Constant:	75 μ sec.	150 μ sec.	125 μ sec. ⁽¹⁾	250 μ sec. ⁽¹⁾
Large Signal Frequency Response:	2 KHz	0.5 KHz	2 KHz	0.5 KHz
Stewing Rate:	6V/ μ sec.	6V/ μ sec.	6V/ μ sec.	6V/ μ sec.
Load Recovery Time Constant:	100 μ sec.	100 μ sec.	125 μ sec. ⁽¹⁾	250 μ sec. ⁽¹⁾

⁽¹⁾ Calculated for a load resistance equal to $E_O \text{ max}/I_O \text{ max}$. Current channel dynamics are a function of the load resistance and the tabulated value for the equivalent output capacitance. $T = R_L C_O$ and f-3 dB = $1/2\pi R_L C_O$. The rate limit is the ratio of current setting to the tabulated output capacitance.

TABLE 1-3 DYNAMIC SPECIFICATIONS

1-8 MISCELLANEOUS FEATURES

A) OUTPUT RANGE: The BOP can be locally (front panel) adjusted, or remotely programmed, from (-) 100% to (+) 100% of its specified d-c voltage and current range. The Class A bipolar output stage permits operation as either a SOURCE OR A SINK. (See FIG. 1-3).

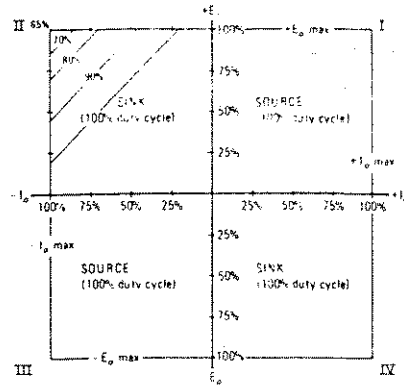

NOTE: Operation in the second quadrant of the graph must be derated as indicated.

FIG. 1-3 BOP OUTPUT CHARACTERISTIC

Note: The BOP is operating as a SOURCE if the direction of its output voltage is *the same* as the direction of its output current. The BOP is operating as a SINK if the direction of its output voltage is *opposite* that of its output current. An illustrative case is shown in FIG. 1-4, where the BOP is programmed to deliver a sine wave output and where the load produces a phase shift between the output voltage and current.

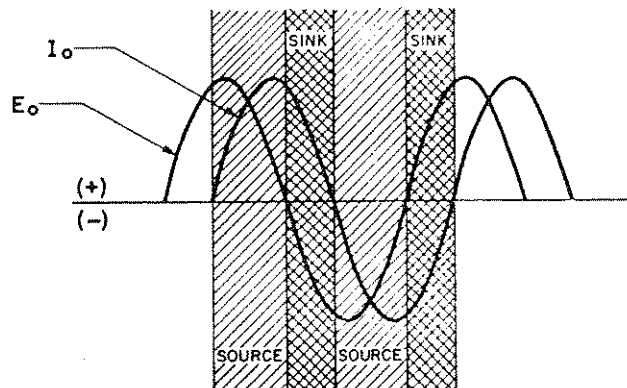

FIG. 1-4 BOP OUTPUT WAVE FORM WITH PHASE SHIFT

- B) REFERENCES: Two reference/bias sources ($\pm 10V - 1 \text{ mA MAX.}$) are provided for control and biasing purposes. These reference sources are available at the rear programming connector (with reference to the "COMMON" terminal). Their specifications are tabulated in Table 1-2.
- C) OFFSET NULLING: Controls are provided to zero the initial offsets (E_{IO}, I_{IO}) of both the voltage and current control preamplifiers.
- D) LOAD REACTANCE: To realize the full high speed potential of the BOP, the load characteristics should be mainly resistive. Load capacitance and inductance up to $0.01 \mu\text{F}$ and 0.5 mH respectively can be tolerated without performance deterioration. **CAUTION: Stable operation into a purely inductive load in the Current Mode of operation requires a minimum series resistance of 25 ohms.**
- E) SERIES OR PARALLEL OPERATION: Not recommended.
- F) VOLTAGE CONTROL CHANNEL (Refer to Section III - FIG. 3-1A). The BIPOLAR VOLTAGE AMPLIFIER, with a fixed gain of 50 (BOP-500M) or 100 (BOP-1000M) is connected, via the MODE switch, to the (unity gain) VOLTAGE PREAMPLIFIER. If the BIPOLAR voltage switch is "on", the BOP output voltage can be locally controlled by means of the (front panel) (\pm) 10 volt bias source from (-) 100% (through zero) to (+) 100% of the rated value. The VOLTAGE PREAMPLIFIER is provided with a ZERO control and all its terminals are available at the rear programming connector for remote control of the output voltage. Control methods are described in Section III of this manual.
- G) MODE SWITCH: The BOP is equipped with a front panel mounted MODE SWITCH, which selects bipolar voltage or bipolar current control.
- H) CURRENT CONTROL CHANNEL (Refer to Section III - FIG. 3-1B). The BIPOLAR CURRENT AMPLIFIER, with a fixed gain of 8 mA/V (BOP-500M) or 4 mA/V (BOP-1000M), is connected via the MODE switch to the (unity gain) CURRENT PREAMPLIFIER. If the BIPOLAR voltage switch is "on", the BOP output current can be locally (front panel) controlled (by means of the ± 10 volt bias source) from (-) 100% (through zero) to (+) 100% of the rated value. The CURRENT PREAMPLIFIER is provided with a ZERO control and all its terminals are available at the rear programming connector for remote control of the output current. Control methods are described in Section III of this manual.
- J) BOUNDING: (Refer to Section III - FIG. 3-1C & D). The BOP has four adjustable output voltage/current limiting circuits: (-) E_O LIMIT, (+) E_O LIMIT, (-) I_O LIMIT, (+) I_O LIMIT for overvoltage/overcurrent protection in either operating mode. All limiting circuits can be screwdriver adjusted by means of four front panel controls. In addition, all four limits can be remotely controlled by means of 0 to 10 volt d-c control voltages. The four limits may be programmed independently or the (\pm) voltage and (\pm) current limits can be controlled in pairs. The adjustable/programmable limit controls are backed-up by non-adjustable limit circuits which define the four boundaries [(\pm) E_O MAX. and (\pm) I_O MAX.] of the BOP, and provide protection against accidental overprogramming of the adjustable limits.
- K) MODE LIGHTS AND FLAG SIGNAL OUTPUT: Four (4) front panel (LED type) indicator lamps monitor the prevailing operating mode of the BOP. In addition, four (4) corresponding flag signal outputs are provided at the rear programming connector. For each operating condition (VOLTAGE MODE, CURRENT MODE, $\pm E_O$ LIMIT, $\pm I_O$ LIMIT) the corresponding indicator lamp lights up and the associated flag signal changes its state from (TTL) logic "1" to "0". NOTE: If operating against back-up limit (PAR. J) all 4 lights go *out*.
- L) STANDARDS: BOP models are designed and tested in accordance with NEMA Standard for Stabilized Power Supplies, d-c output, Publication No. PY-1-1972.

1-9 MECHANICAL SPECIFICATIONS

- A) DIMENSIONS: See "Mechanical Outline Drawing", FIG. 1-5.
- B) FINISH: See "Mechanical Outline Drawing", FIG. 1-5.
- C) FRONT PANEL METERS: $2\frac{1}{2}$ inches wide, recessed. Accuracy $\pm 2\%$ full scale. Two (2) "zero center" meters monitoring the \pm d-c voltage and the \pm d-c current are provided.

1-10 ACCESSORIES

- A) MOUNTING FLANGES, for installation of the BOP into a standard (19-inch) equipment rack. (A PAIR INCLUDED WITH EACH BOP). Kepeco Part No. 128-1282 (right), 128-1281 (left).
- B) SIDE COVER PLATES, for bench top use, designed to finish the two sides of the instrument when the rack mounting ears are not mounted. A pair included with each BOP. Kepeco P/N 128-1285 (right), 128-1284 (left).
- C) REAR PROGRAMMING CONNECTOR, Kepeco Model PC-9, 30-terminal printed circuit connector for all rear programming connections and flag signal outputs (ONE INCLUDED WITH EACH BOP)

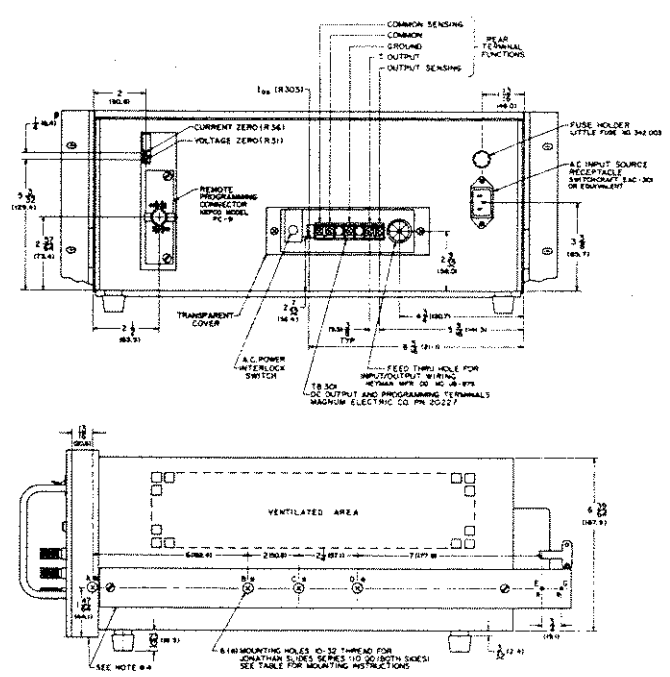
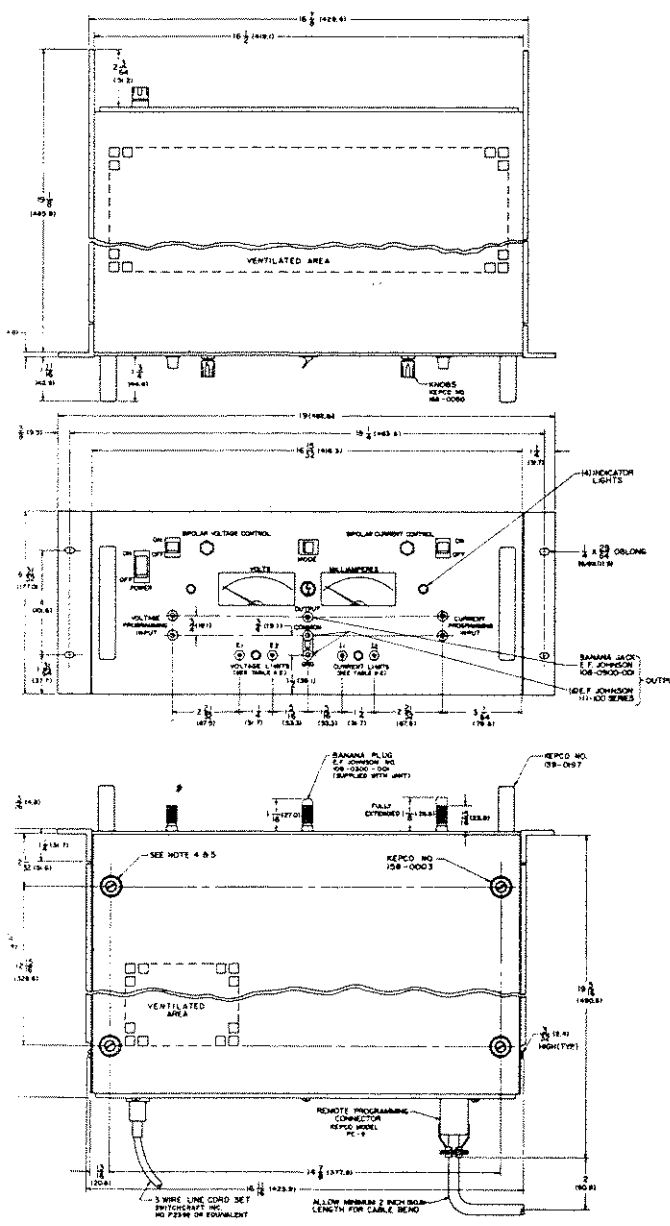

TABLE #1

SLIDE TYPE	USE MOUNTING HOLES					
	A	B	C	D	E	G
110-00-20-2		NOT USED		NOT USED		
110-00-22-2		NOT USED		NOT USED	NOT USED	B
110-00-24-2		NOT USED		NOT USED		NOT USED

NOTE: * "G" HOLE HAS TO BE ADDED TO SLIDES #110-00-22-2, 0199 04 "B" FROM "A" HOLE

TABLE #2

MODEL	VOLTAGE LIMITS		CURRENT LIMITS	
	E1	E2	I1	I2
BOP 500M	500V	0	1500V	40MA
BOP 1000M	1000V	0	4000V	40MA

- NOTES**
- THIS DRAWING IS USED FOR MODELS BOP 500M AND BOP 1000M.
 - MATERIAL: A CHASSIS-3/16 GA. C.R.S. B FRONT PANEL-1/8 THICK ALUMINUM C COVER-1/16 GA. C.R.S.
 - FINISH: A CHASSIS-CADMIUM PLATE WITH CHROMATE WASH B FRONT PANEL-LIGHT GRAY PER FEDERAL STD 595, COLOR #26440 C COVER-CHARCOAL GRAY VINYL TEXTURE
 - FIXED ANGLE BRACKETS AND CHASSIS SLIDE SUPPORT BARS (BOTH SIDES) USED FOR RACK OR CABINET INSTALLATION CAN BE REMOVED FOR BENCH OPERATION.
 - RACK OR CABINET MOUNTING REMOVE (4) PLASTIC FEET
 - (4) PLASTIC MOUNTING INSERTS FOR 8-18 THREAD CUTTING SCREWS, 5/8" LONG (WITH 1/8" THICK MOUNTING PLATE).
 - IF INSTALLATION WITHOUT SLIDES IS DESIRED, THE UNIT MUST BE SUPPORTED BY A RIGID PLATFORM OR BY FIXED BRACKET MOUNTED ON THE RACK SLIDES AND RIGID PLATFORM NOT SUPPLIED.
 - DIMENSIONS IN PARENTHESES ARE IN MILLIMETERS
 - TOLERANCES: A) BETWEEN MOUNTING HOLES ±.004 (±.04) B) ALL FRONT PANEL DIMENSIONS TO MIL STD 189 C) ALL OTHER DIMENSIONS ±.002 (±.02), EXCEPT AS NOTED.

FIG. 1-5 MECHANICAL OUTLINE DRAWING, BOP-H.V.

SECTION II – INSTALLATION

2-1 UNPACKING AND INSPECTION

2-2 This instrument has been thoroughly inspected and tested prior to packing and is ready for operation. After careful unpacking, inspect for shipping damage before attempting to operate. Perform the preliminary operational check as outlined in PAR. 2-8. If any indication of damage is found, file an immediate claim with the responsible transport service.

2-3 TERMINATIONS

- a) FRONT PANEL: Refer to FIG. 2-2A and Table 2-2.
- b) REAR: Refer to FIG. 2-2B and Table 2-2.
- c) INTERNAL CALIBRATION CONTROLS: Refer to FIG. 2-1 and Table 2-1.

REFERENCE DESIGNATION	CONTROL	PURPOSE	ADJUSTMENT PROCEDURE
R18	(±) 10V CAL.	Reference Voltage Calibration	Sect. V, par. 5-8A
R31	E_o ZERO	E_o Pre-amp Zero Adjustment	Sect. III, par. 3-16
R36	I_o ZERO	I_o Pre-amp Zero Adjustment	Sect. III, par. 3-30
R303	I_{ox}	I_o Stabilization Compensation	Sect. V, par. 5-8B

TABLE 2-1 INTERNAL CALIBRATION CONTROLS

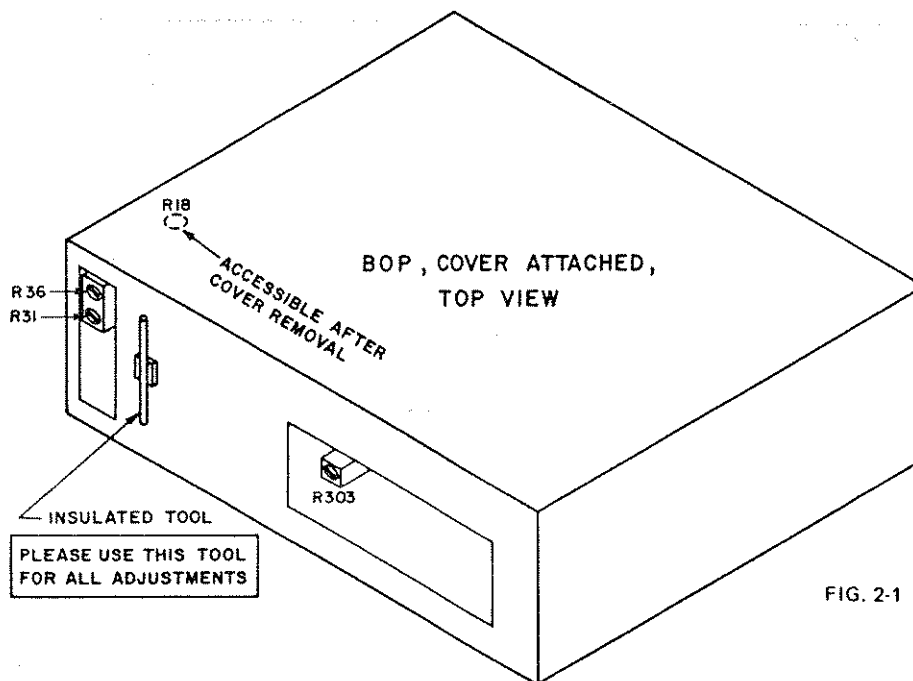
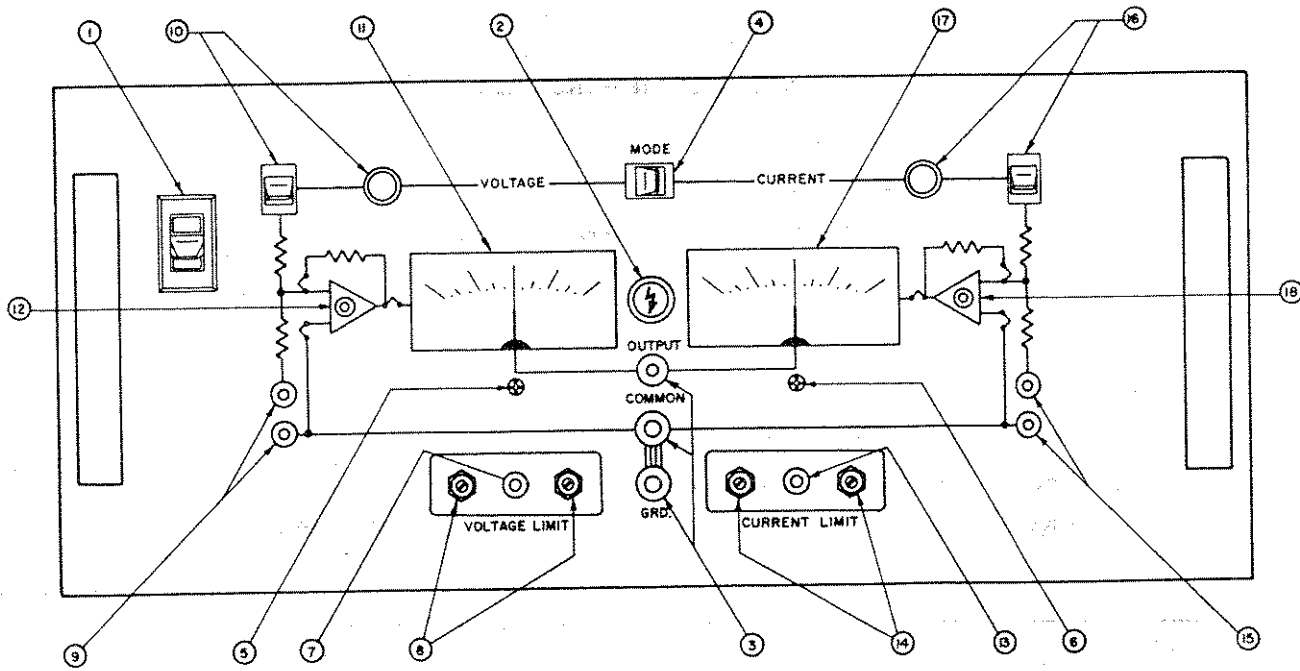
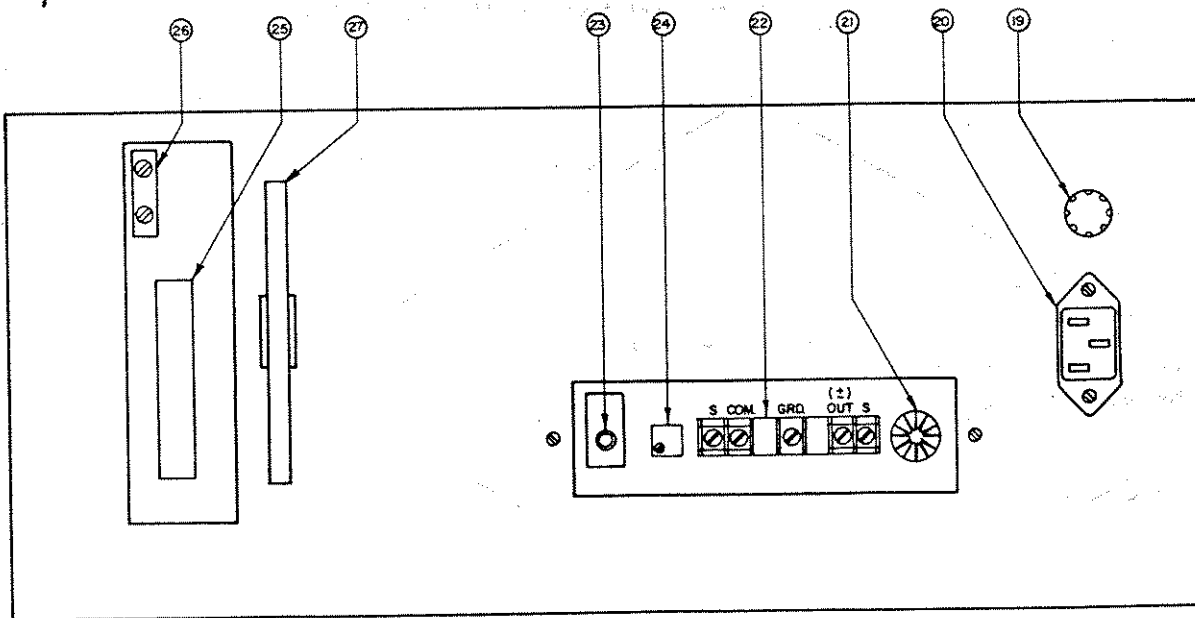

FIG. 2-1 LOCATION OF INTERNAL CALIBRATION CONTROLS.



A) BOP FRONT TERMINATIONS AND CONTROLS



B) BOP REAR TERMINATIONS AND CONTROLS

FIG. 2-2 BOP TERMINATIONS AND CONTROLS

NO.	NAME OF CONTROL OR FUNCTION	FUNCTION
1	A-C POWER	A-C INPUT POWER SWITCH AND INDICATOR LAMP.
2	-	OUTPUT "READY" LAMP. ENERGIZES 30 SEC. AFTER A-C POWER IS TURNED ON.
3	\pm OUTPUT, COMMON, GRD.	OUTPUT AND GROUNDING TERMINALS (PARALLEL WITH REAR BARRIER STRIP TERMINALS).
4	MODE	OPERATING MODE SELECTOR SWITCH FOR "VOLTAGE" OR "CURRENT" MODE.
5	-	MECHANICAL VOLTMETER ZERO ADJUSTMENT.
6	-	MECHANICAL CURRENT METER ZERO ADJUSTMENT.
7	VOLTAGE LIMIT	LED LAMP, INDICATING VOLTAGE LIMITING OPERATION.
8	\pm VOLTAGE LIMIT	CONTROLS FOR MANUAL ADJUSTMENT OF THE (\pm) VOLTAGE LIMITS.
9	INPUT	PROGRAMMING INPUT TERMINALS FOR VOLTAGE PRE-AMP.
10	BIPOLAR VOLTAGE CONTROL	"ON-OFF" SWITCH AND VOLTAGE CONTROL. FOR MANUAL ADJUSTMENT OF THE BOP D-C OUTPUT VOLTAGE (WITH SWITCH "ON")
11	E_o METER	D-C OUTPUT VOLTMETER (READS ALSO AVERAGE A-C SIGNALS)
12	E_o MODE	LED LAMP, INDICATING VOLTAGE MODE OPERATION.
13	CURRENT LIMIT	LED LAMP, INDICATING CURRENT LIMITING OPERATION.
14	\pm CURRENT LIMIT	CONTROLS FOR MANUAL ADJUSTMENT OF THE (\pm) CURRENT LIMITS.
15	INPUT	PROGRAMMING INPUT TERMINALS FOR CURRENT PRE-AMP.
16	BIPOLAR CURRENT CONTROL	"ON-OFF" SWITCH AND CURRENT CONTROL. FOR MANUAL ADJUSTMENT OF THE BOP D-C OUTPUT CURRENT (WITH SWITCH "ON")
17	I_o METER	D-C OUTPUT CURRENT METER (READS ALSO AVERAGE A-C SIGNALS)
18	I_o MODE	LED LAMP, INDICATING CURRENT MODE OPERATION.
19	FUSE	A-C POWER FUSE. PROTECTS PRIMARY A-C INPUT CIRCUIT.
20	-	A-C POWER INPUT JACK. ACCEPTS 3-WIRE LINE CORD (SUPPLIED).
21	-	CABLE HOLDER. ACCEPTS OUTPUT, SENSING AND GROUND WIRES FOR FEED-THROUGH FROM TERMINALS THROUGH SAFETY COVER.
22	REAR TERMINALS	REAR BARRIER STRIP WITH OUTPUT, SENSING AND GROUND TERMINALS.
23	INTERLOCK	SHUTS OFF BOP IF SAFETY COVER IS REMOVED. CAN BE DEFEATED BY FORWARD PULL.
24	INT. I_{ox} CONTROL	R303, COMPENSATION ADJUSTMENT. SEE SECTION V.
25	REAR CONNECTOR	ACCESS TO INTERNAL CIRCUITRY FOR PROGRAMMING CONNECTIONS.
26	INT. CONTROLS	R31, R36, CURRENT AND VOLTAGE PRE-AMP ZERO CONTROLS.
27	INSULATED TOOL	USE THIS TOOL FOR ALL INTERNAL ADJUSTMENTS.

TABLE 2-2 BOP TERMINATIONS AND CONTROLS

Note: Numbers correspond to those shown in FIG. 2-2.

2-4 A-C POWER INPUT REQUIREMENTS

2-5 The BOP is equipped with a SOURCE VOLTAGE SELECTOR permitting the user to choose between 115 and 230V a-c operation by means of a screwdriver actuated switch. The switch location is illustrated in FIG. 2-3. When changing the a-c input voltage, the A-C POWER FUSE must be altered as well, according to the information given in FIG. 2-3.

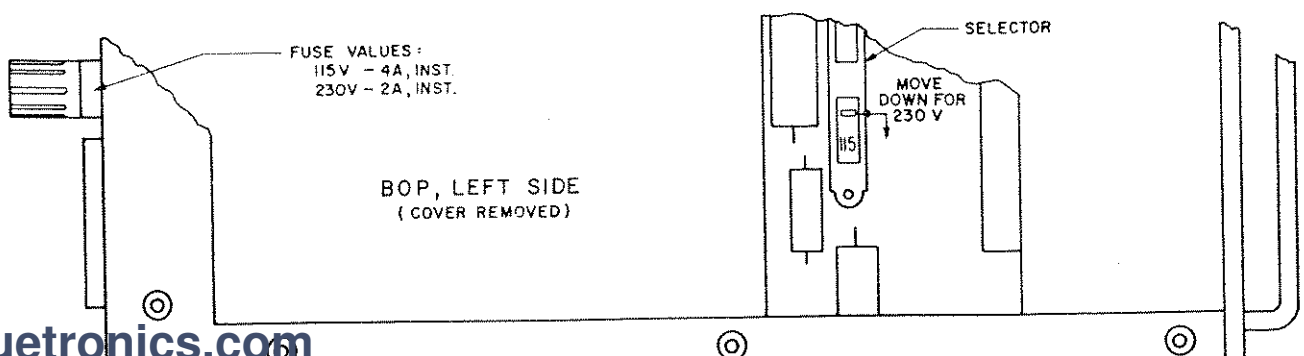

2-6 COOLING

2-7 The components in the BOP power supply rely on convection cooling for the maintenance of their operating temperature. SIDE PANEL OPENINGS AND THE TOP OF THE CASE MUST BE KEPT CLEAR FROM ALL OBSTRUCTIONS TO ENSURE PROPER AIR CIRCULATION. Periodic cleaning of the interior of the power supply is recommended. If the BOP is rack-mounted or installed into confined spaces, care must be taken that the ambient temperature (the temperature immediately surrounding the power supply) does not rise above 65°C (≈ 180°F).

2-8 PRELIMINARY CHECKOUT

NOTE: THE REAR PROGRAMMING CONNECTOR MUST BE ATTACHED TO THE BOP AND MUST BE WIRED AS SHOWN ON THE MAIN SCHEMATIC DIAGRAM, SECTION VI, FIG. 6-5.

2-9: A simple operating check after unpacking and before permanent installation, is advisable to ascertain whether the BOP has suffered damage in shipment. Refer to FIG. 2-2 and Table 2-2 FOR THE LOCATION AND DESIGNATION OF THE OPERATION CONTROLS AND TERMINALS. Proceed as follows:

- A) Connect the BOP to a 115V a-c source, or refer to PAR. 2-4 for conversion to 230V a-c operation if required.
- B) Note: The rear sensing links must be attached to the rear terminals of the BOP as shown in FIG. 2-2 and the rear connector must be attached and secured.
- C) Set the BOP front panel controls as follows (refer to FIG. 2-2. The controls will be identified here and in the following manual text with the nomenclature used in Table 2-2 and identifying numbers used in FIG. 2-2):
 - 1) MODE switch (4), set to "voltage."
 - 2) BIPOLAR VOLTAGE CONTROL (10), set switch to "ON", control to its extreme counterclockwise position.
 - 3) A-C POWER switch to "ON."
- D) The indicator lamp, part of the A-C POWER switch (1) will be "on." After approximately 30 seconds, the output "READY" lamp (2) and the "E₀ MODE" Lamp (12) will be "on."
- E) Turn the BIPOLAR VOLTAGE CONTROL (10) clockwise through its range, while observing the front panel "E₀ METER" (11). The BOP output voltage should smoothly follow from the maximum negative output voltage, over zero, to the maximum positive output voltage of the BOP. Turn A-C POWER SWITCH (1) "off".
- F) Connect a short circuit between the (±) OUTPUT to the COMMON front panel output terminals (3). Set the BOP front panel controls as follows:
 - 1) MODE SWITCH (4), set to "CURRENT".
 - 2) BIPOLAR CURRENT CONTROL (15), set switch to "ON", control to its maximum counterclockwise position.
 - 3) A-C POWER switch "ON".
- G) The indicator lamp, part of the A-C POWER switch (1) will be "on". After approximately 30 seconds, the output "READY" lamp (2) and the "I₀ MODE" Lamp (18) will be "on".
- H) Turn the BIPOLAR CURRENT CONTROL (15) clockwise through its range, while observing the front panel "I₀ METER" (16). The BOP output current should smoothly follow from the maximum negative output current, over zero, to the maximum positive output current of the BOP. Turn A-C POWER switch (1) "off". Remove the short circuit from the output terminals. THIS CONCLUDES THE PRELIMINARY CHECK-OUT OF THE BOP.

2-10 INSTALLATION (Refer to FIG. 2-4)

2-11 The BOP is delivered with mounted FILLER and ANGLE BRACKETS and ready for installation into any standard (19-inch) instrument rack. Please refer to PAR. 2-6 (COOLING) if the BOP is to be mounted into a multiple rack installation.

2-12 For bench-operation, the FILLER BRACKETS can be removed and the ANGLE BRACKETS can be replaced with the provided SLIDE COVER PLATES. Instructions for slide installation are provided in FIG. 2-4.

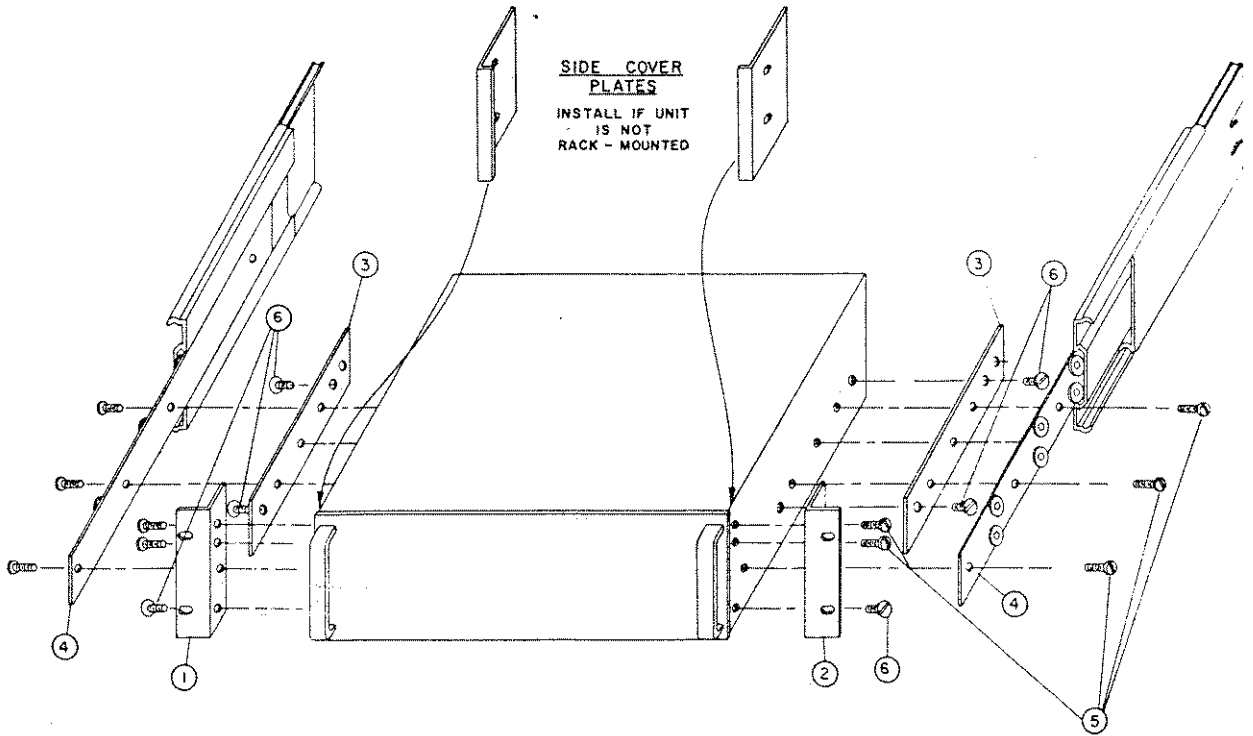

RACK MOUNTING ACCESSORIES, PART LIST.

ITEM	DESCRIPTION	QTY.
1	FRONT ANGLE LEFT	1
2	FRONT ANGLE RIGHT	1
3	FILLER BRACKET	2
4	SLIDES 110 QD JONATHAN SERIES	2
5	10-32 SCR. BDG. HD.	10
6	10-32 FLATHEAD B2*	6

NOTES: ITEM (4) NOT SUPPLIED

INSTRUCTIONS FOR SLIDE INSTALLATION

- 1) Items 1, 2, 3 are installed at the factory.
- 2) Item 3 (filler bracket) is pre-drilled and tapped for Jonathan Slides, Series 110 QD. Remove the three binding head screws on each side of Item 3. (These screws are part of Item 5.)
- 3) Line up slide with filler bracket and re-insert the binding head screws through the appropriate mounting holes in the slide.
- 4) If Jonathan Slide 110 QD-24-1 is used, an additional hole must be drilled into the slide. See FIG. 1-3 for further information.

FIG. 2-4 RACK INSTALLATION OF THE BOP.

NOTE: If slide installation (as described above) is not desired, other means of supporting the unit in the rear must be provided (additional rear brackets or a solid platform, for example) since the front angle brackets (Items 1, 2) alone are not sufficient to support the full weight of the unit.

SECTION III – OPERATION

3-1 INTRODUCTION

- 3-2 BOP BIPOLAR OPERATIONAL POWER SUPPLIES can be used in a great variety of applications. As a PRECISION VOLTAGE or CURRENT SOURCE, the BOP output can be controlled locally (by means of the front panel BIPOLAR voltage and current controls) or remotely (by means of resistances or by voltage signals). Independently adjustable (or remotely programmable) limit circuits for both output voltage and output current protect a sensitive load from any overvoltage or overcurrent. As a BIPOLAR AMPLIFIER, the BOP output responds to such input signals as sine, square or triangular waves. A (\pm) 10 volt input signal will program the BOP output (voltage or current) through its rated output ranges. Built-in preamplifiers, for the voltage, as well as the current channel of the BOP, permit amplification of the control signals to the required amplitude and the interface with high as well as low impedance signal sources.
- 3-3 Detailed examples of the more popular applications are described in the following paragraphs. Before actual operation, however, the following general comments on the operation of the BOP should be carefully considered.

WARNING

THIS INSTRUMENT IS CAPABLE OF PRODUCING LETHAL VOLTAGES:

- 1) Exercise extreme care in making all connections to and from the BOP terminals. REMOVE A-C POWER FROM THE BOP BEFORE MAKING ANY CONNECTIONS!
- 2) An interlock device removes the A-C source power from the BOP if the rear terminal cover plate is lifted. DO NOT BYPASS THE INTERLOCK!
- 3) Wires and/or cables, connected from the BOP terminals to external components or programming devices must be properly insulated and securely terminated on both sides to make accidental touch impossible. A feed-through hole is provided on the BOP rear terminal cover, to bring the wires from the BOP rear terminals to the outside. DO NOT USE BANANA PLUGS WITH EXPOSED SCREWS OR OTHER EXPOSED METAL PARTS AT THE FRONT PANEL OUTPUT TERMINALS!
- 4) The BOP chassis and cover must be safety-grounded to a reliable a-c source ground. A safety-ground may be established by using a grounded a-c power outlet or, if the latter is not available, by means of a separate wire, from the provided "ground" terminal to a reliable a-c source ground point.
- 5) THE COMMON OUTPUT TERMINAL OF THE BOP SHOULD BE SIGNAL GROUNDED. If for any reason, grounding of the output is not possible, additional precautions must be taken to make any access to the isolated output impossible.
- 6) FOR ALL CONTROL ADJUSTMENTS ON THE BOP, USE ONLY THE INSULATED TOOL WHICH IS ATTACHED AT THE REAR. (See Section II, FIG. 2-2)

- A) DIAGRAMS. Application and test set up diagrams on the following pages show the symbolic and simplified representation of the BOP circuitry in four (4) separate diagrams, as indicated on FIG. 3-1. The diagrams represent the four programmable circuits of the BOP.
- A) Voltage Control Channel
 - B) Current Control Channel
 - C) (\pm) E_O Limit Circuits
 - D) (\pm) I_O Limit Circuits

The *complete* simplified diagram is represented in the fold-out diagram at the end of Section IV. THE FOUR CIRCUITS CAN BE PROGRAMMED SEPARATELY AS DESCRIBED IN THE EXAMPLES IN THIS SECTION, OR THEY CAN BE USED SIMULTANEOUSLY AS THE APPLICATION REQUIRES, WITH THE EXCEPTION OF THE TWO (2) MAIN BIPOLAR VOLTAGE AND CURRENT CHANNELS WHICH ARE SELECTED BY THE FRONT PANEL MODE SWITCH AND CANNOT BE OPERATED SIMULTANEOUSLY.

The numbered terminals in the diagrams correspond to the connector terminals on the REAR PROGRAMMING CONNECTOR.

NOTE: BOP's have front and rear output terminals. Only the front terminals are shown on all subsequent simplified diagrams.

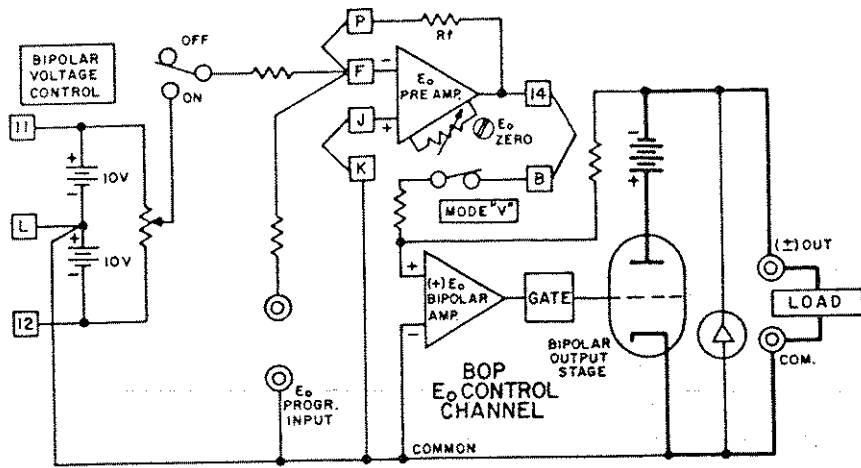

FIG. 3-1A BOP VOLTAGE CONTROL CHANNEL

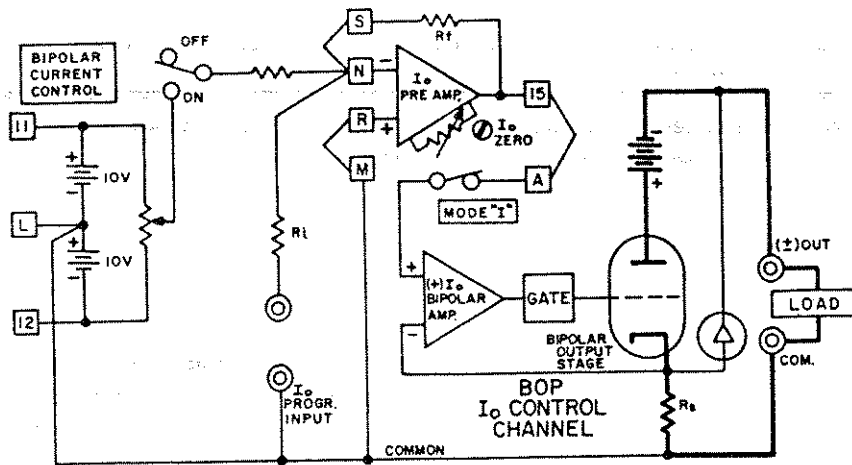

FIG. 3-1B BOP CURRENT CONTROL CHANNEL

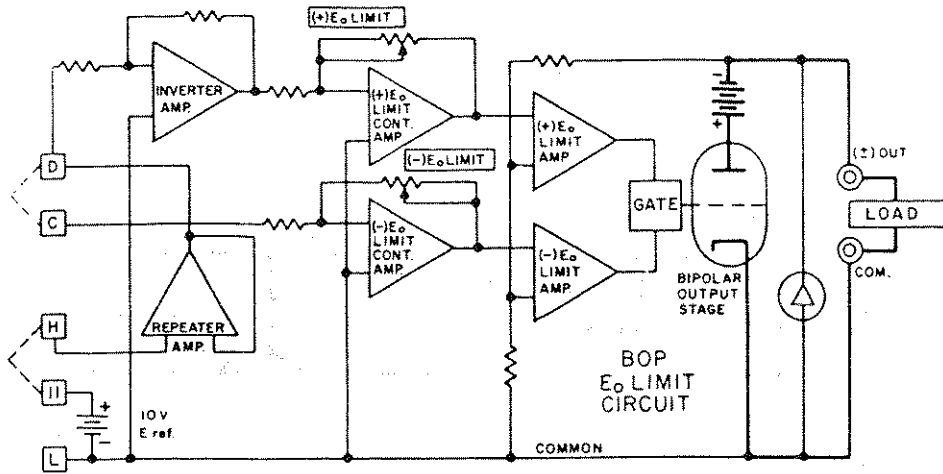

FIG. 3-1C BOP (±) VOLTAGE LIMITING CIRCUIT

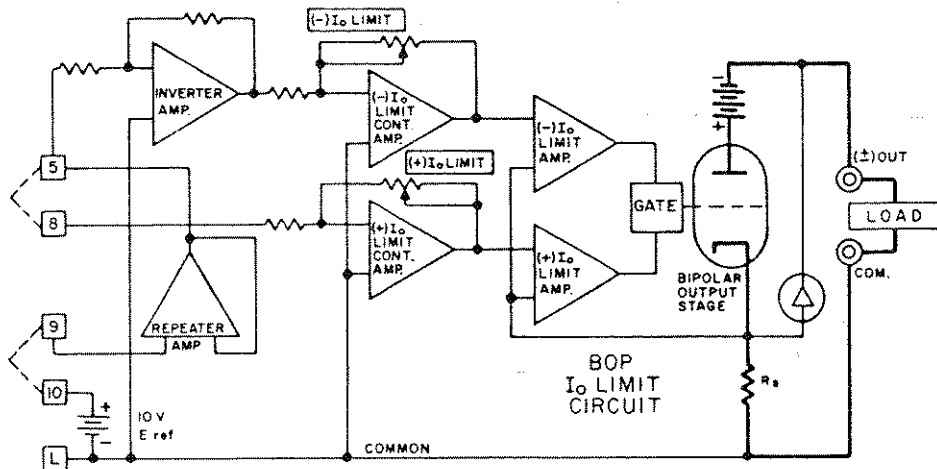

FIG. 3-1C BOP (±) CURRENT LIMITING CIRCUIT

- B) **LOAD CONNECTION (1).** The basic interconnection between the BOP and the load are shown in FIG. 3-2. The load wire size for the 2-wire connection shown should be as large as practicable to keep the series resistance and inductance low. In addition, the load wire pair should be tightly twisted, to reduce possible "pick-up" from stray magnetic fields. The basic 2-wire connection is useful where the voltage drop in the load wires is of minor consequence, as for example, operation into a constant load or in a constant current operating mode.

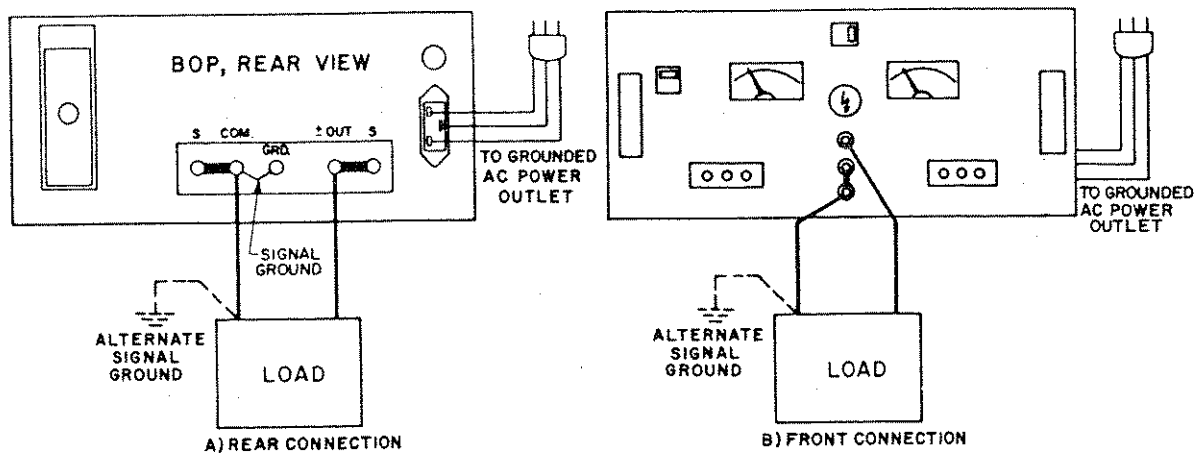

FIG. 3-2 BASIC 2-WIRE LOAD CONNECTION AND GROUNDING CONNECTIONS BETWEEN THE BOP AND THE LOAD.

- C) **LOAD CONNECTION (11).** The recommended load connection for all applications requiring minimum load effect across a remote load is shown in FIG. 3-3. A twisted, shielded pair of wires (No. 20 AWG minimum) are connected from the BOP sensing terminals to the load. This "remote error sensing" technique will compensate for load wire voltage drops up to 0.5 volts per wire.

NOTE: OBSERVE POLARITIES:
 THE COMMON SENSING WIRES MUST GO TO THE COMMON LOAD WIRE. THE (±) OUT SENSING WIRE MUST GO TO THE (±) OUT LOAD WIRE.

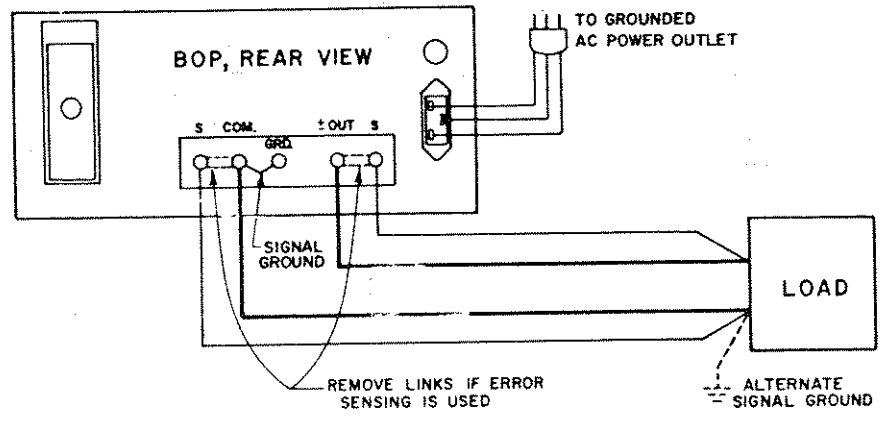

FIG. 3-3 LOAD CONNECTION WITH ERROR SENSING AND GROUNDING CONNECTIONS BETWEEN THE BOP AND THE LOAD.

WARNING

- D) **A-C SAFETY GROUND.** (Refer to FIG.'s 3-2, 3-3). The dangerous voltages present in this equipment make it imperative that the case be kept at ground potential at all times. If the 3-wire line cord with 3-prong safety plug (supplied with this equipment) is used in combination with a properly grounded outlet, this is taken care of automatically. If an adapter for a non-grounded outlet is used, however, the case must be grounded separately. A separate "GROUND" terminal is provided for this purpose on the rear of the BOP. (See Section II, FIG. 2-2).
- E) **D-C (SIGNAL) GROUND.** (Refer to FIG.'s 3-2, 3-3). Specified ripple and noise figures for operational power supplies are valid only with the common side of the output/load circuit returned to a common ground point (refer to Section I, Table 1-2). The common side of the BOP output is shown grounded in FIG.'s 3-2 and 3-3, since it is "common" to both internal reference source and any external signal source. If the application requires, the "common" side of the BOP may be floated up to 500V d-c off ground. In this case, however, the common mode current (specified in Section I, PAR. 1-6E, will flow through the impedance of whatever circuit is placed between common and ground and will give rise to a common mode voltage. The signal ground point in the BOP/load circuit must consist of a single point only, to which all input source grounds, shields and load grounds are connected. Multiple signal grounds in the BOP output/load circuit may cause "ground-loop" problems, since noise signals develop across the impedances between the multiple ground points. The exact physical location of the "best" single ground point must be carefully selected for minimum ripple/noise output.
- F) **EXTERNAL PROGRAMMING RESISTORS.** External programming resistors should be high-quality units, with low-temperature coefficients. Resistors should be selected carefully, since in most applications, the limitations for stability and drift are due, not to the BOP, but to the programming resistors. Selection criteria for resistors are:
- 1) TEMPERATURE COEFFICIENT
 - 2) LEAKAGE (IN VALUES ABOVE 100 k OHM)
 - 3) HUMIDITY EFFECTS
 - 4) DRIFT WITH TIME
 - 5) SELF-HEATING (POWER DISSIPATION)
 - 6) TOLERANCE
- G) For variable resistors (potentiometers or rheostats) similar selection criteria apply. In addition, such specifications as listed below should be carefully considered if the application requires:
- 1) END RESISTANCE
 - 2) LINEARITY
 - 3) CAPACITIVE AND INDUCTIVE EFFECTS
- H) **ACTIVE PROGRAMMING SOURCES.** External programming sources (Signal Generators, etc.) or reference sources should have temperature coefficients and drift specifications comparable to (or better than) the BOP Power Supply. CAUTION: A-C source-operated programming sources must have their output isolated from the case.
- J) **EXTERNAL LEADS.** Shielded (preferably twisted) lead pairs are recommended for all input connections to the BOP control channels. The shield should be connected (single-ended) to the chosen signal ground point. Shielded leads should be held as short as practicable. Output leads must be "high-voltage" wire, rated at least for the maximum BOP output voltage.

3-4 BEFORE USING THE BOP IN ANY APPLICATION . . . PLEASE REFER TO SECTION II TO GET ACQUAINTED WITH THE OPERATING CONTROLS, THE TURN-ON SEQUENCE AND THE A-C POWER REQUIREMENTS. REFER TO THIS SECTION (SECTION III) FOR INFORMATION ON LOAD CONNECTIONS AND GROUNDING. READ THE "WARNING" NOTE, FOLLOWING PAR. 3-3.

3-5 BOP OPERATION WITH LOCAL (FRONT PANEL) OUTPUT CONTROL

3-6 **VOLTAGE MODE OPERATION WITH CURRENT LIMITING.** The BOP may be used as a stabilized (d-c) source of positive or negative voltage with output current limiting for either polarity pre-selected for the application at hand.

3-7 PROCEDURE

- 1) Determine the output voltage and current requirements of your load. Set the BOP MODE switch to the VOLTAGE position and the BIPOLAR VOLTAGE CONTROL SWITCH to ON.
- 2) With the BOP A-C POWER switch "off", connect a short circuit across the output terminals. Turn the BOP "on" again; wait 30 seconds.
- 3) Adjust the I_O LIMIT CONTROLS for both polarities as required, monitoring the OUTPUT CURRENT METER for the correct limiting value. Proceed as follows: Turn BIPOLAR VOLTAGE CONTROL fully counterclockwise. Adjust the "(-) I_O LIMIT CONTROL". Turn the BIPOLAR VOLTAGE CONTROL fully clockwise. Adjust the "(+) I_O LIMIT CONTROL. Turn the BIPOLAR VOLTAGE CONTROL to the center of its range. Turn the A-C POWER switch "off" and remove the short circuit from the output and reconnect the load.
- 4) Turn the A-C POWER SWITCH "on" again; wait 30 seconds, and adjust the operating voltage by means of the BIPOLAR VOLTAGE CONTROL to the value required.

NOTE: If the output current exceeds the pre-adjusted value at any time, the VOLTAGE MODE LIGHT will go out and the $(\pm)I_O$ LIMIT LIGHT will go on. After the cause of the overcurrent is eliminated, the indicator lights will return to their initial status.

3-8 CURRENT MODE OPERATION WITH VOLTAGE LIMITING. The BOP may be used as a stabilized d-c source of positive or negative current, with output voltage limiting for either polarity, pre-selected for the application at hand.

3-9 PROCEDURE (please refer to PAR. 3-4)

- 1) Determine the output current and voltage requirement of your load. Perform I_O LIMIT adjustment as described in PAR. 3-7, steps 2 and 3. Set the BOP MODE SWITCH to the CURRENT position and the BIPOLAR CURRENT CONTROL switch to ON.
- 2) Turn the A-C POWER SWITCH "on", wait 30 seconds and adjust the $(\pm)E_O$ LIMIT CONTROLS to the required output (compliance) voltage. Turn the A-C POWER SWITCH "off."
- 3) Connect the load and turn A-C POWER SWITCH "on" again and wait 30 seconds. Adjust the required operating current by means of the BIPOLAR CURRENT CONTROL as required.

3-10 BOP OPERATION WITH REMOTE CONTROL OF THE VOLTAGE CONTROL CHANNEL

3-11 REMOTE D-C OUTPUT VOLTAGE CONTROL BY RESISTANCE. As seen in FIG. 3-4, and as described in a previous paragraph (PAR. 3-6) the BOP d-c output potential can be controlled within its specified range by means of the BIPOLAR VOLTAGE CONTROL, with the BIPOLAR VOLTAGE CONTROL SWITCH in the ON position. Since the E_O PRE-AMP, with the built-in feedback and input resistors, has a gain of one, and the E_O BIPOLAR AMP have respective gains of 50 (BOP-500M) and 100 (BOP-1000M), a d-c input signal of zero to $(\pm)10V$ will control the BOP output through its specified range. In the local (front panel) control mode, the d-c control potential is applied via the BIPOLAR VOLTAGE CONTROL.

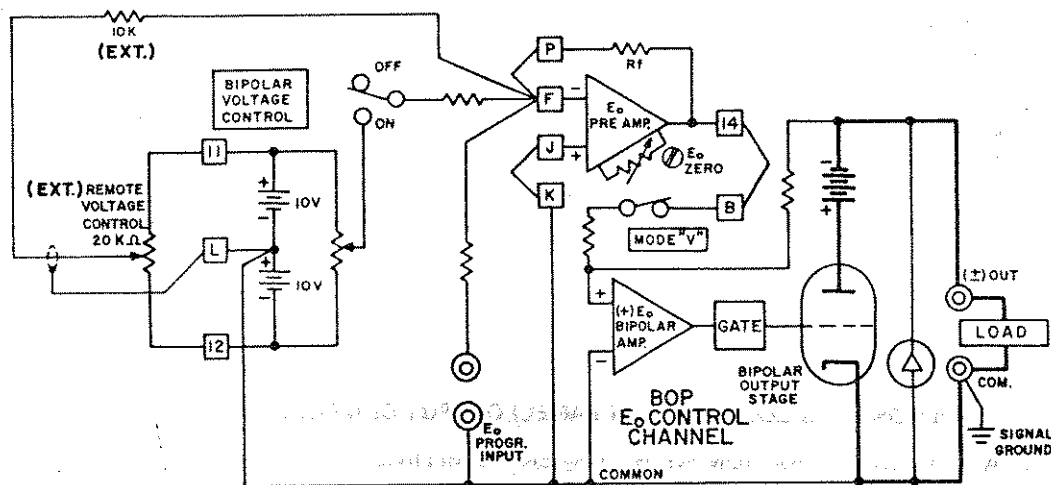

- 3-12 As shown in FIG. 3-4, this control method can readily be performed remotely, by setting the BIPOLAR VOLTAGE CONTROL SWITCH to the OFF position and connecting an external REMOTE VOLTAGE CONTROL as indicated in FIG. 3-4.
- 3-13 Two-terminal resistance control of the d.c. output voltage (for example, by means of a Decade Box) can be exercised as shown in FIG. 3-5.

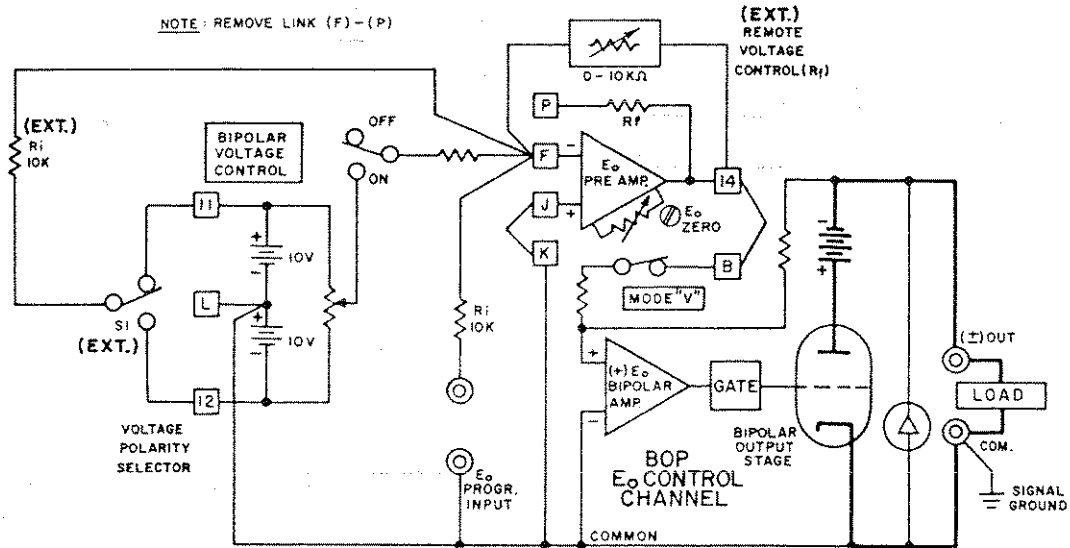

FIG. 3-5 REMOTE D-C OUTPUT VOLTAGE CONTROL BY MEANS OF A TWO-TERMINAL RESISTANCE (DECADE).

- 3-14 The external switch (S1), connected across the (±) reference voltage is used to pre-select either positive or negative output, by setting it to the applicable reference voltage polarity.
- 3-15 The E_o PRE-AMP functions here as an inverter. Its output can be expressed by the equation:

$$E_o \text{ (PRE-AMP)} = - E_{ref} (R_f/R_i) \quad \begin{array}{l} R_f = \text{Decade Resistor} \\ R_i = \text{Ext. Input Resistor} \end{array}$$

Since $E_{ref} = (\pm)10$ volts and the gain ratio R_f/R_i is variable from zero to one, its output voltage (E_o PRE-AMP) will vary linearly from zero to $(\pm)10$ volt, with the change in the decade resistance (R_f). As a consequence, the BOP output voltage will also vary linearly with the change in decade resistance.

- 3-16 This programming system can be calibrated very accurately by setting the REMOTE VOLTAGE CONTROL (Decade) to zero and adjusting zero output volts at the BOP E_o ZERO control, monitoring at the BOP output with a digital voltmeter. The maximum output voltage is calibrated by making all or part of R_i a rheostat and adjusting it, with the REMOTE VOLTAGE CONTROL at maximum resistance, to the maximum BOP output voltage.
- 3-17 **REMOTE D-C VOLTAGE CONTROL BY MEANS OF D-C SIGNAL VOLTAGE.** The BOP d-c output voltage can be controlled directly by a $(\pm) 10V$ d-c signal, applied to the front panel E_o PROGRAM INPUT terminals. An interesting example of this application is the BOP output voltage control with a Kepco Model SN-12R Digital Programmer. The Model SN-12R responds to a complementary offset binary input coding and can be addressed either by a computer, or manually. The output signal of the Model SN-12R is from zero to $(\pm) 10$ volt and constitutes the input program for the BOP.

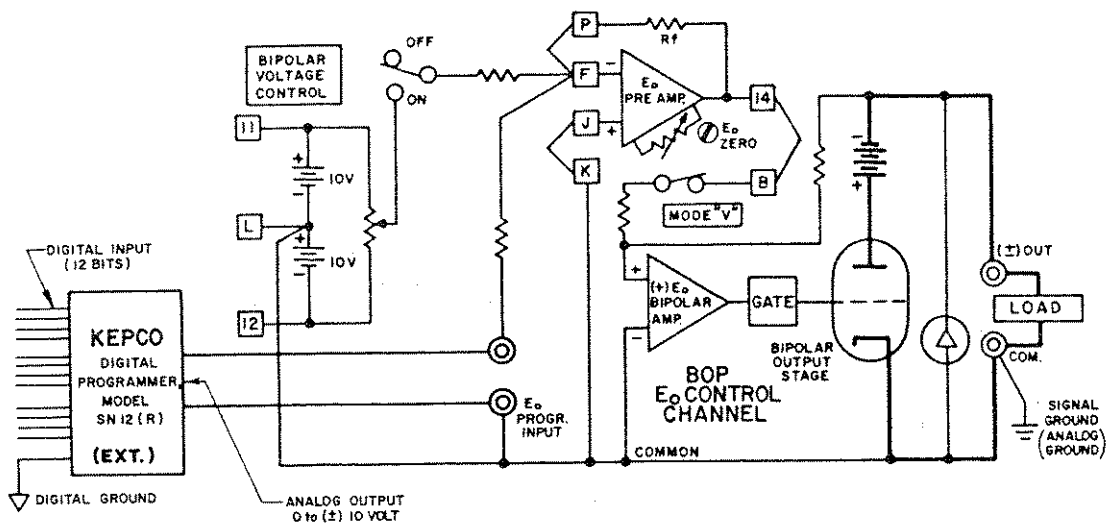
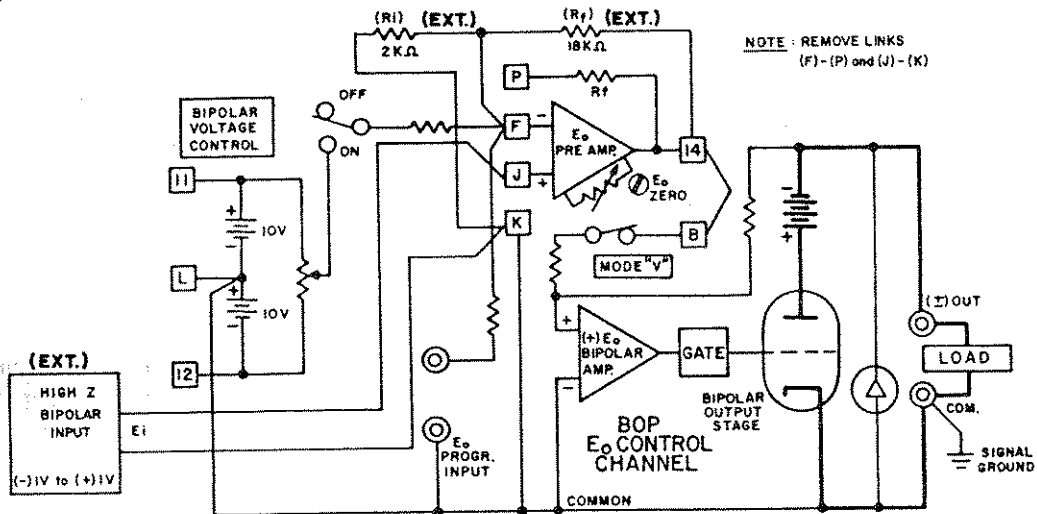

FIG. 3-6 DIGITAL CONTROL OF THE BOP D-C OUTPUT VOLTAGE

- 3-18 The connections between the SN-12R and the BOP are illustrated in FIG. 3-6. This programming system provides a resolution of 12-bits with a linearity of $(\pm) 0.01\%$. The digital and the power supply grounds are isolated (optical isolation) to 1000 volts. Calibration of the system is performed with the provided controls on the SN-12R Programmer.
- 3-19 Since all terminals of the E_0 PRE-AMP are available at the REAR PROGRAMMING CONNECTOR, d-c output voltage control can be exercised in many other ways. The E_0 PRE-AMP can be treated as an uncommitted operational amplifier, with its applicable transfer-functions. Its initial offsets can be zeroed with the provided E_0 ZERO Control, while the offset variations are specified in Section I of this manual (refer to Table 1-2). The basic principle of d-c output voltage control of the BOP is that a control voltage of $(\pm) 10$ volts at 1 mA at the E_0 PROGRAM INPUT (with the built-in feedback/input resistors) will produce the full d-c output voltage swing of the BOP. If the selected control signal does not have the required amplitude or if the required control current cannot be supplied, the E_0 PRE-AMP configuration can be altered to provide the proper interface for the application.
- 3-20 If, for example, the BOP d-c output voltage is to be controlled by means of a bipolar, 1 volt, high impedance source, it can be connected to the BOP as shown in FIG. 3-7.



- 3-21 As seen in FIG. 3-7, the original input feedback components of the E_O PRE-AMP have been bypassed and are replaced by external resistors (small, metal film or wirewound type resistors may be used and connected directly to the REAR PROGRAMMING CONNECTOR terminals as shown). The E_O PRE-AMP is used in the non-inverting configuration. Its output voltage (the necessary BOP control voltage) is given by:

$$E_O (\text{PRE-AMP}) = E_i \left(\frac{R_f + R_i}{R_i} \right) = (\pm) 1V \left(\frac{18k + 2k}{2k} \right) = (\pm) 10V$$

Consequently, as the BIPOLAR INPUT VOLTAGE (E_i) is controlled from (-) 1V over zero to (+) 1V, the BOP output voltage will follow over its specified range. Calibration of the system can be performed at the programming source, or the E_O PRE-AMP zeroing control can be used for the low end, while the feedback resistor ($R_f = 18k$) can be trimmed to calibrate the high end of the range.

3-22 THE BOP AS AN AMPLIFIER

- 3-23 If, instead of the previously used d-c control signal, an a-c signal voltage is applied to the E_O PROGRAM INPUT, the BOP functions as a bipolar amplifier. As an amplifier, the BOP has a voltage gain of 50 (BOP-500M) and 100 (BOP-1000M) respectively, so that (as before with the d-c control signal) a bipolar a-c input signal with an amplitude of 20V (peak-to-peak) will drive the BOP output through its specified (\pm) output voltage range. All other dynamic specifications are given in Section I, Table 1-3.
- 3-24 The BOP can be used to amplify, sum or scale a variety of waveshapes, some of which are illustrated in FIG. 3-8. All input signals are shown in phase with their corresponding output waveshape. The latter can be readily produced 180° out of phase (i.e. with the output wave taking the exact opposite direction of the input signal) by addressing the non-inverting input of the E_O PRE-AMP instead of the front panel E_O PROGRAM INPUT (Inverting).

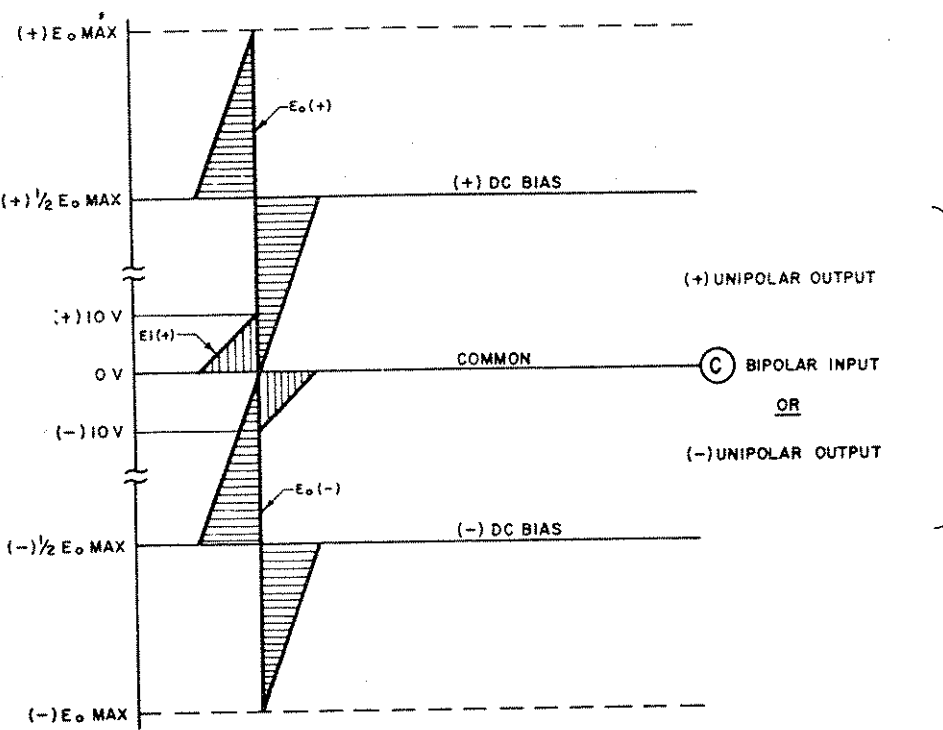
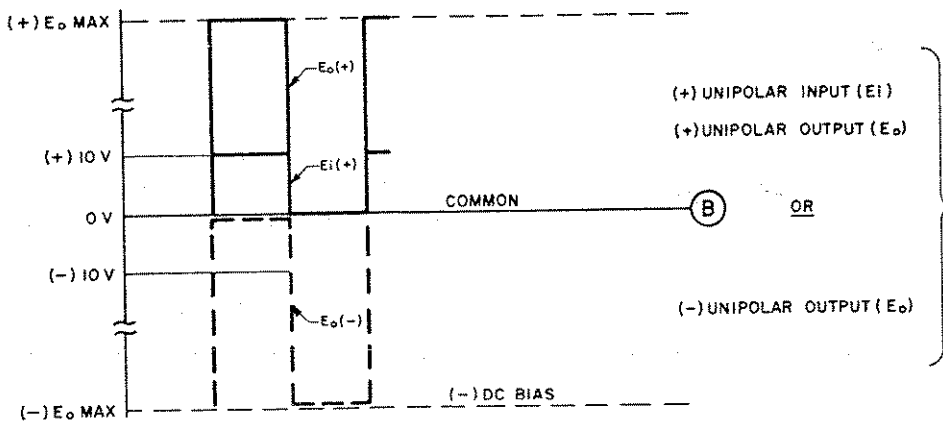
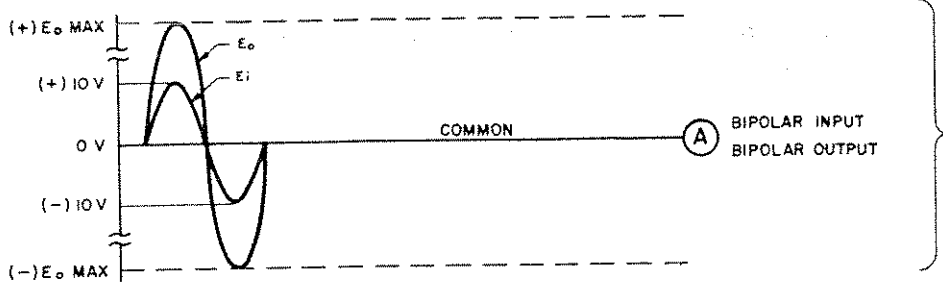

FIG. 3-8 GRAPHS OF POSSIBLE BOP INPUT/OUTPUT WAVE SHAPES

3-25 The basic programming circuit with which all the wave forms shown in FIG. 3-8 can be produced is shown in FIG. 3-9. Since all input signals in FIG. 3-8 are shown with a ± 10 volt amplitude, the basic programming circuit in FIG. 3-9 must be modified if the external signal source cannot produce 10 volts and if the full BOP output voltage swing is required.

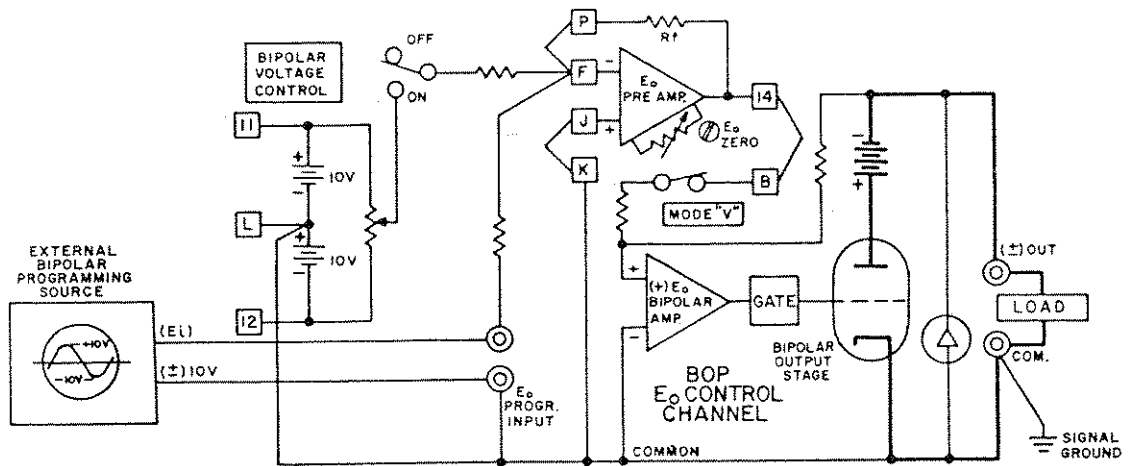

FIG. 3-9 BASIC PROGRAMMING CIRCUIT FOR USE OF THE BOP AS A BIPOLAR AMPLIFIER (VOLTAGE MODE)

3-26 If the EXT. PROGRAMMING SOURCE does not have sufficient amplitude to drive the BOP over its full output range, the gain of the E_o PRE-AMP must be changed from the built-in 1V per volt value to suit the application. To calculate the required components for the new gain requirement, the output equation for the E_o PRE-AMP in the inverting configuration is used:

$$E_o \text{ (PRE-AMP)} = -E_i (R_f/R_i)$$

where $E_o \text{ (PRE-AMP)} = \pm 10V$, and the values of R_f and R_i depend on the available amplitude of the programming source. If, for example, a ± 1 volt source is available, the ratio R_f/R_i must be 10, and the two resistor values can be 10k and 100k respectively. The built-in resistor ($R_i = 10k$) can be retained, and only R_f must be replaced with a 100k metal film (1/2 watt) unit. The necessary connections are illustrated in FIG. 3-10. Gain control (1 to 10) can be exercised by making R_f a rheostat instead of a fixed resistor.

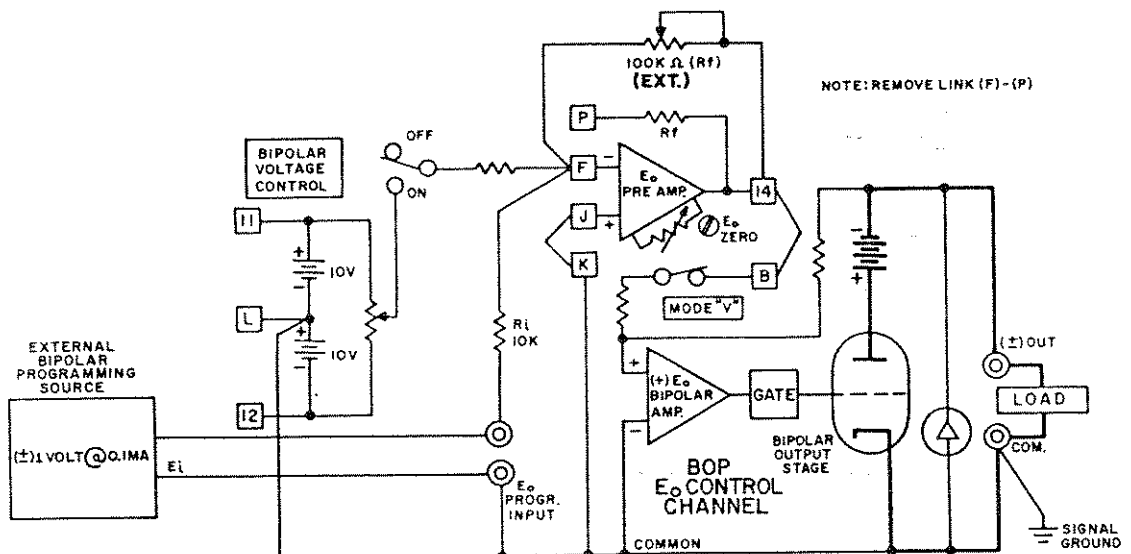

FIG. 3-10 PROGRAMMING CIRCUIT FOR DRIVING THE BOP OUTPUT VOLTAGE WITH A BIPOLAR (+1V) SIGNAL

3-27 The non-inverting input of the E_o PRE-AMP is used for applications where the external programming source has a high impedance and/or cannot supply the necessary 0.1 mA drive current, or where a negative going output swing is desired for a positive going input signal. The necessary connections are illustrated in FIG. 3-11 for a E_o PRE-AMP GAIN of unity (with the built-in value for R_i retained and a short across R_f), although other gain configurations can be chosen, according to the output equation for the non-inverting configuration:

$$E_o \text{ (PRE-AMP)} = E_i \frac{R_f + R_i}{R_i}$$

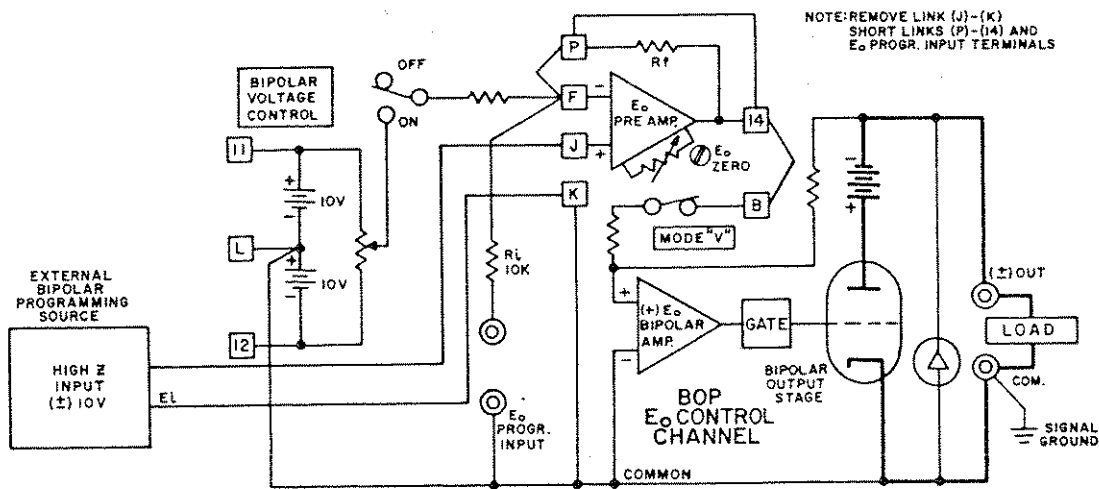

FIG. 3-11 PROGRAMMING CIRCUIT FOR DRIVING THE BOP OUTPUT VOLTAGE WITH A HIGH-IMPEDANCE SOURCE, USING THE NON-INVERTING INPUT OF THE PRE-AMPLIFIER

3-28 BOP OPERATION WITH REMOTE CONTROL OF THE CURRENT CONTROL CHANNEL

3-29 GENERAL: In the local (front panel) control mode, the BOP output current can be controlled by means of the BIPOLAR CURRENT CONTROL, with the BIPOLAR CURRENT CONTROL SWITCH closed, and the MODE SWITCH in the "CURRENT" position, over the full output range. The control potential zero to (\pm) 10V is applied to the I_o PRE-AMP, operating with unity gain, to the I_o BIPOLAR AMP which drives the BIPOLAR OUTPUT STAGE with a fixed gain of 8 mA per volt (BOP-500M) and 4 mA per volt (BOP-1000M) respectively. A d-c control signal from zero to (\pm) 10 volts will, therefore, control the BOP output current through its specified range (refer to FIG. 3-12).

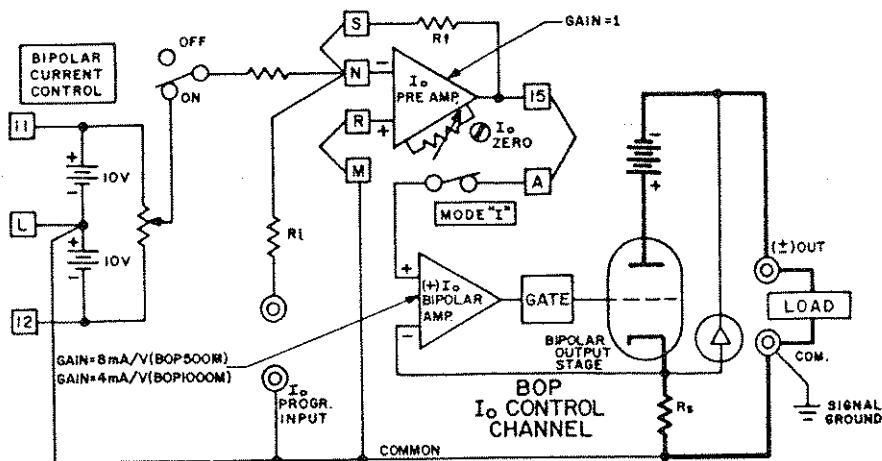

FIG. 3-12 LOCAL (FRONT PANEL) CONTROL OF THE BOP OUTPUT CURRENT WITH THE BIPOLAR CURRENT CONTROL.

3-30 REMOTE CONTROL OF THE BOP CURRENT CHANNEL. Since the requirements for the control of the BOP output current are the same as for programming the output voltage, and since the control circuitry is almost identical, all programming circuit descriptions for programming the output voltage of the BOP can be applied for current programming. The current programming circuits are illustrated in the following diagrams. Any exceptions with respect to current channel programming are noted on the diagrams. NOTE Adjust the "zero" output current point by means of the built-in "I_o ZERO" control.

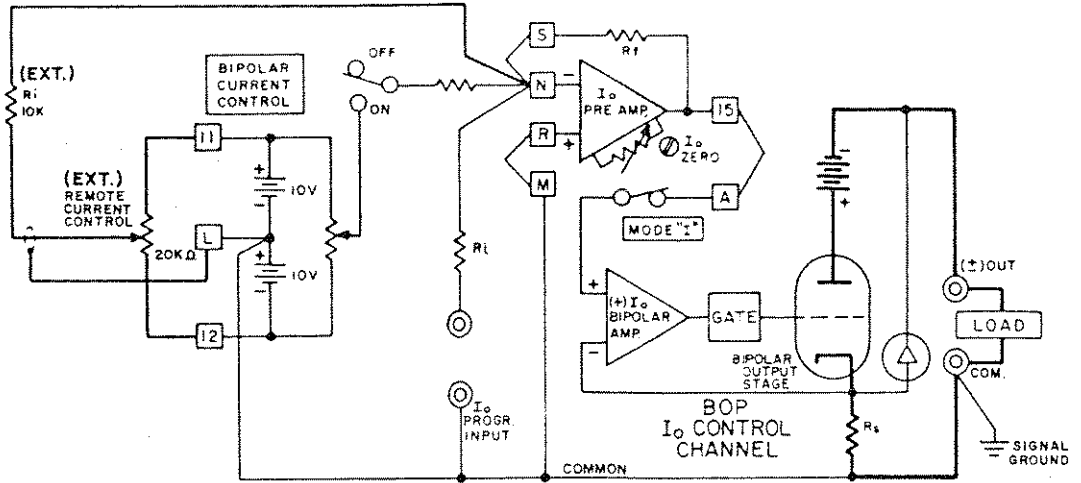

FIG. 3-13 REMOTE POTENTIOMETER CONTROL OF THE BOP OUTPUT CURRENT

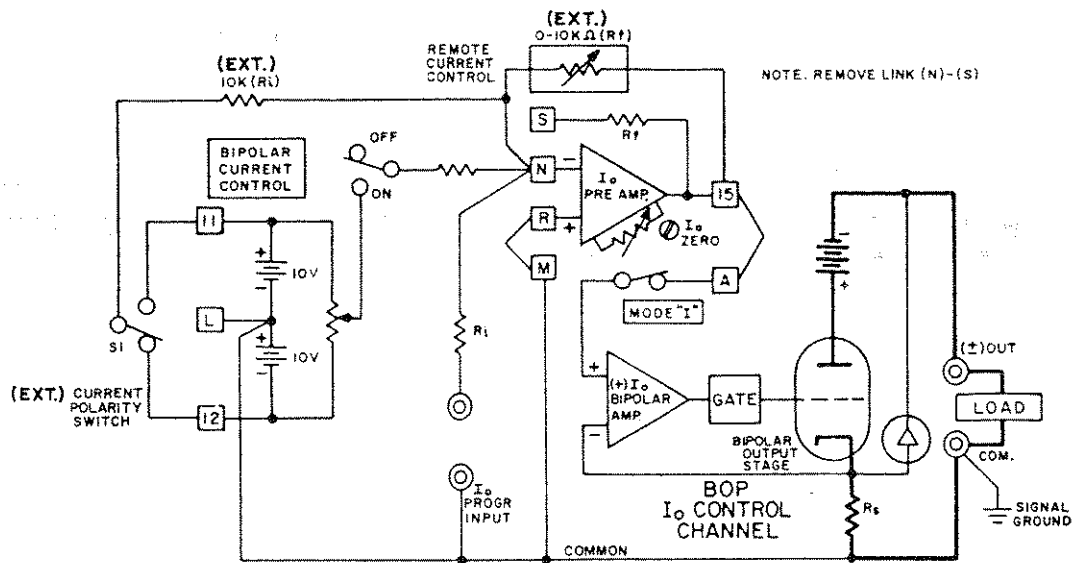

FIG. 3-14 REMOTE OUTPUT CURRENT CONTROL BY MEANS OF A TWO-TERMINAL RESISTANCE.

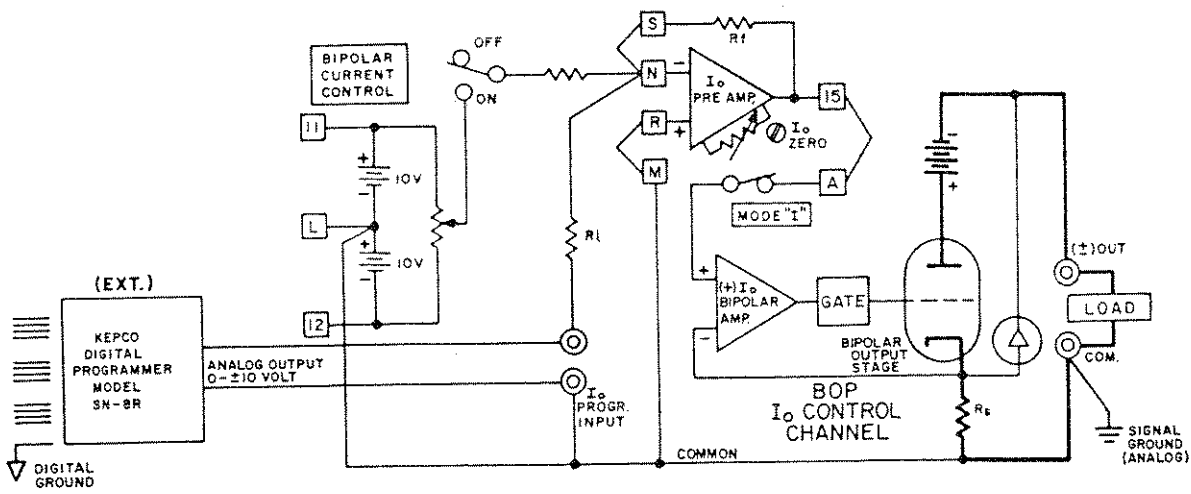

FIG. 3-15 DIGITAL CONTROL OF THE BOP OUTPUT CURRENT

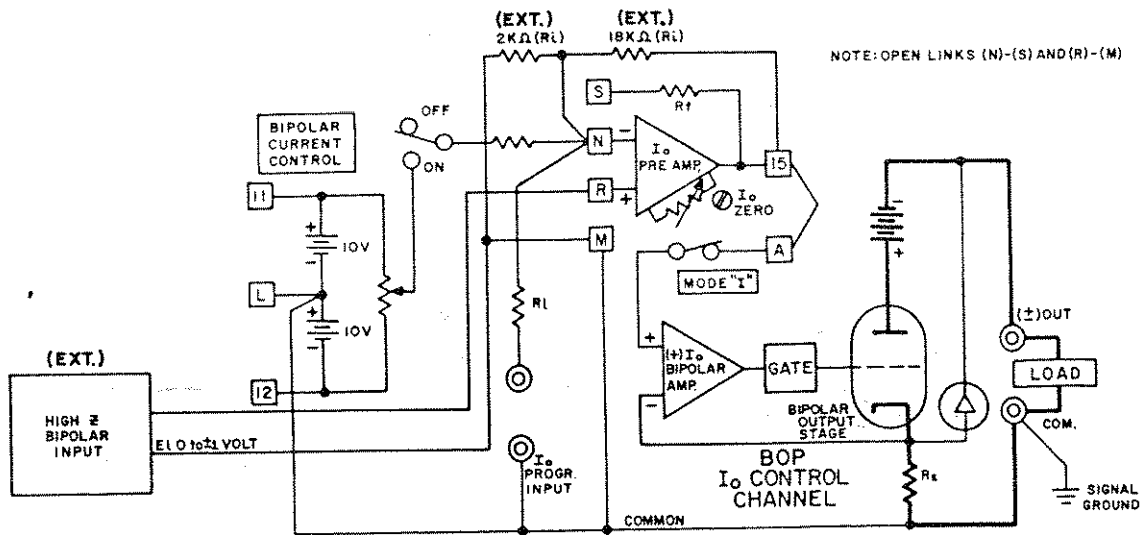

FIG. 3-16 BOP OUTPUT CURRENT CONTROL WITH A HIGH IMPEDANCE (± 1 VOLT) SIGNAL SOURCE

Note: The non-inverting input of the Pre-amplifier is used to prevent loading of the input source.

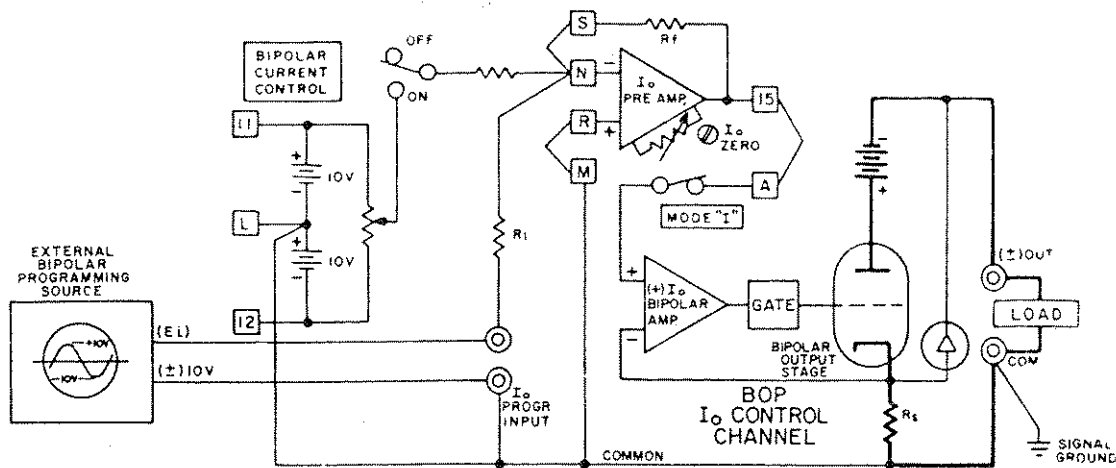

FIG. 3-17 BASIC PROGRAMMING CIRCUIT FOR USE OF THE BOP AS A BIPOLAR CURRENT-STABILIZED AMPLIFIER

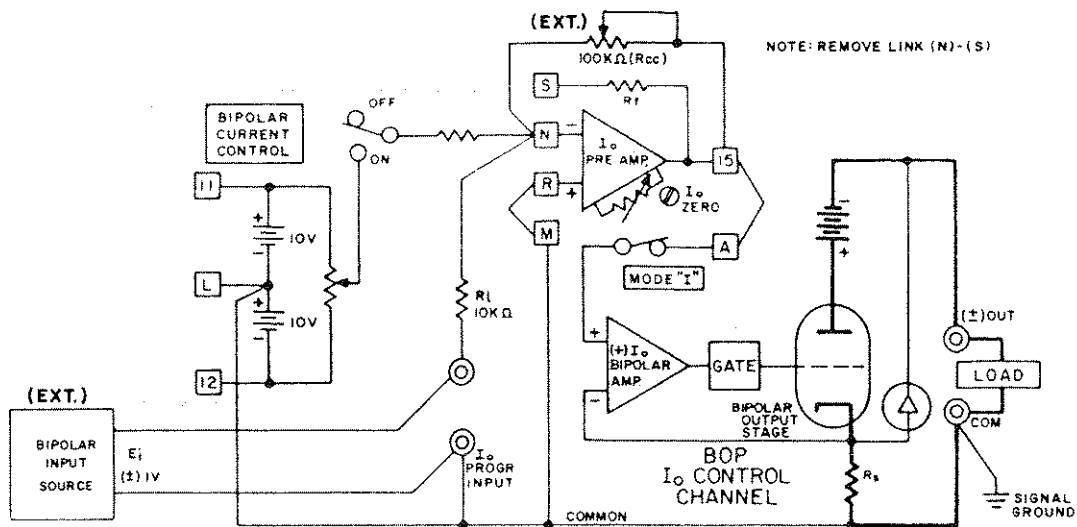

FIG. 3-18 PROGRAMMING CIRCUIT FOR DRIVING THE BOP OUTPUT CURRENT WITH A BIPOLAR SIGNAL LESS THAN $\pm 1V$ (EXAMPLE SHOWN: $\pm 1V$ SOURCE)

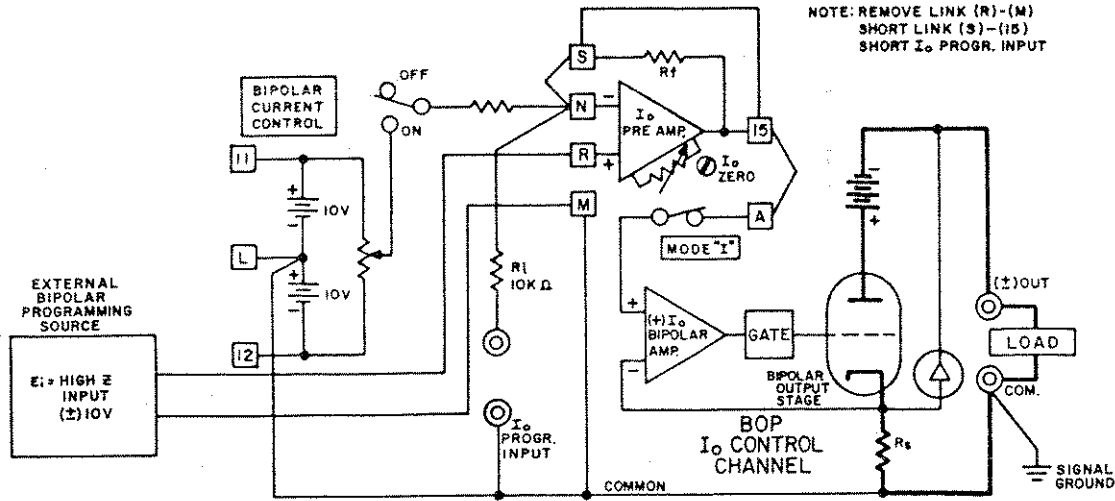

FIG. 3-19 PROGRAMMING CIRCUIT FOR DRIVING THE BOP OUTPUT CURRENT WITH A HIGH IMPEDANCE SOURCE

3-31 REMOTE CONTROL OF THE BOP CURRENT LIMIT

3-32 The BOP I_0 LIMIT CIRCUIT in the local (front panel) control mode is shown in FIG. 3-20. A (+)10 volt reference voltage is repeated and inverted to obtain two reference voltages (+10V and -10V respectively). These references are applied at the input of the two (\pm) I_0 LIMIT CONTROL AMPS. Both control amplifiers operate in the inverting configuration and produce the control potential according to the output equation:

$$E_{Control} = (-) \frac{E_{ref}}{R_i} R_f$$

Since " R_f " is adjustable, the control voltage ($E_{CONTROL}$) can be varied from zero to (+)10V and (-)10V respectively, thus providing output current limit control over the full range of the BOP.

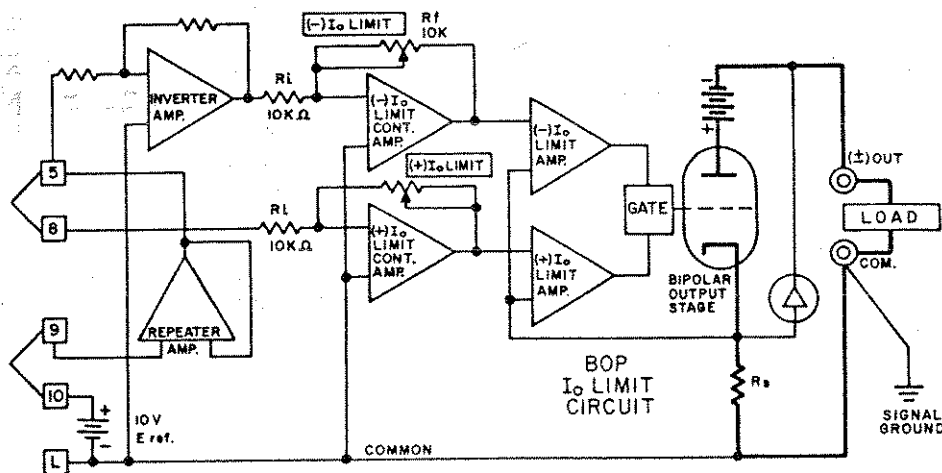

FIG. 3-20 LOCAL (FRONT PANEL) CONTROL OF THE BOP CURRENT LIMIT CIRCUIT.

3-33 The BOP current limits can be remotely controlled by disconnecting the fixed reference potential, setting the front panel controls to their maximum clockwise position, and substituting a variable (0 to 10 volt) reference potential. The two limits may be controlled simultaneously and symmetrically, or separately. The necessary connections are shown in FIG's 3-21 and 3-22 respectively.

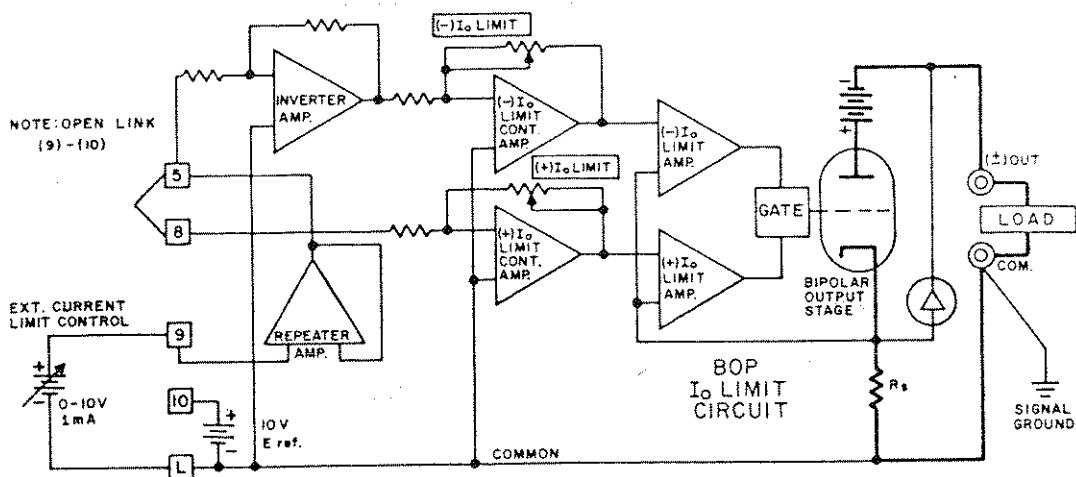

FIG. 3-21 SYMMETRICAL REMOTE CONTROL OF THE BOP CURRENT LIMITS

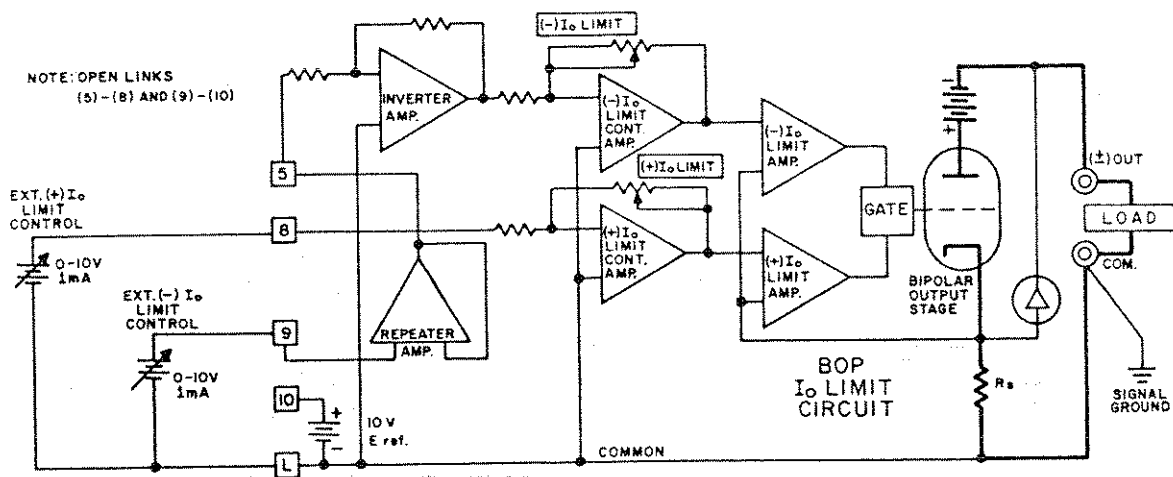

FIG. 3-22 INDEPENDENT REMOTE CONTROL OF THE BOP (+) I_o AND (-) I_o LIMIT

3-34 REMOTE CONTROL OF THE BOP VOLTAGE LIMIT

3-35 The BOP E_o LIMIT CIRCUIT in the local (front panel) control mode is shown in FIG. 3-23. The circuit functions in the same manner as the I_o LIMIT CIRCUIT described previously (refer to PAR. 3-31) and can be remotely controlled symmetrically with a 0 to 10V d-c source, or the (+) and (-) voltage limit can be controlled independently by individual 0 to 10V d-c sources. The necessary circuit connections are illustrated in FIG.'s 3-24 and 3-25. Note: The front panel VOLTAGE LIMIT CONTROLS serve as a "back-up" when remote controlling the voltage limits on the BOP. The front panel VOLTAGE LIMIT CONTROLS should be set to their maximum positions if full range remote control of the BOP voltage limits is desired.

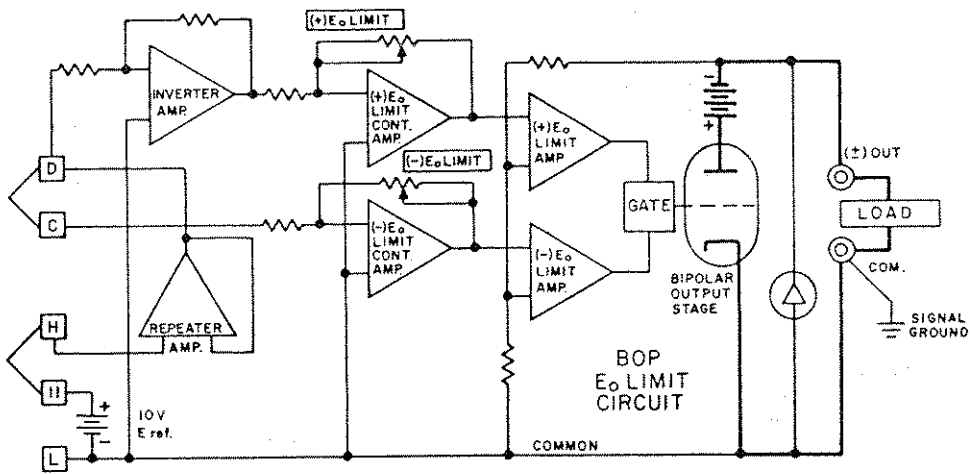

FIG.3-23 LOCAL (FRONT PANEL) CONTROL OF THE BOP VOLTAGE LIMIT CIRCUITS

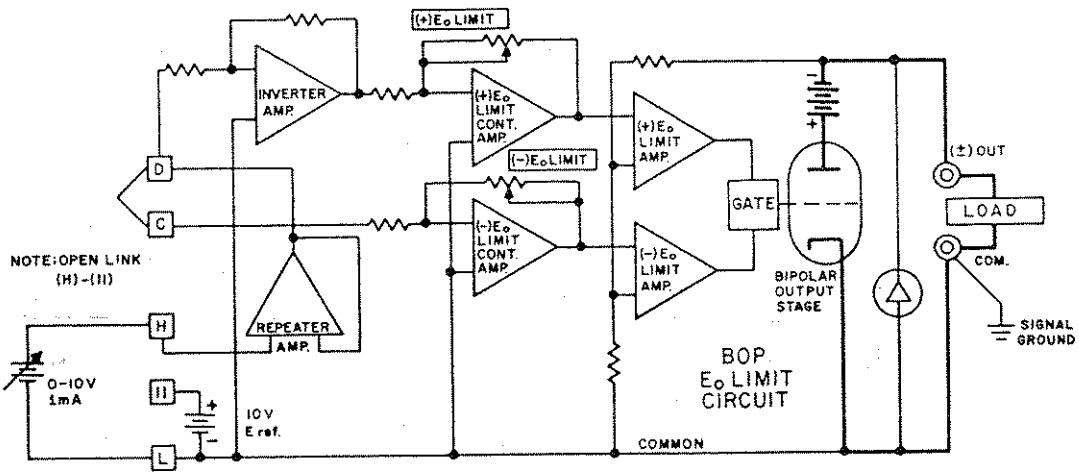

FIG. 3-24 SYMMETRICAL REMOTE CONTROL OF THE BOP VOLTAGE LIMIT CIRCUIT.

NOTE: REMOVE LINKS
(D)-(C) AND (H)-(II)

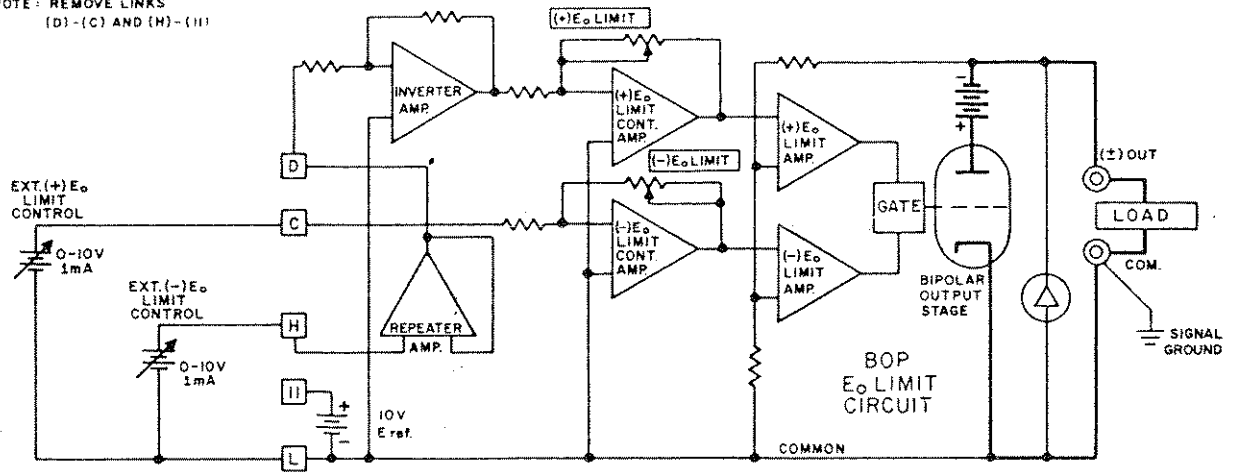

FIG. 3-25 INDEPENDENT REMOTE CONTROL OF THE BOP
(+) AND (-) VOLTAGE LIMIT CIRCUIT

