

Model 7154 **2-Pole High Voltage Scanner Card**

Instruction Manual

Contains Operating and Servicing Information

KEITHLEY

WARRANTY

Keithley Instruments, Inc. warrants this product to be free from defects in material and workmanship for a period of 1 year from date of shipment.

Keithley Instruments, Inc. warrants the following items for 90 days from the date of shipment: probes, cables, rechargeable batteries, diskettes, and documentation.

During the warranty period, we will, at our option, either repair or replace any product that proves to be defective.

To exercise this warranty, write or call your local Keithley representative, or contact Keithley headquarters in Cleveland, Ohio. You will be given prompt assistance and return instructions. Send the product, transportation prepaid, to the indicated service facility. Repairs will be made and the product returned, transportation prepaid. Repaired or replaced products are warranted for the balance of the original warranty period, or at least 90 days.

LIMITATION OF WARRANTY

This warranty does not apply to defects resulting from product modification without Keithley's express written consent, or misuse of any product or part. This warranty also does not apply to fuses, software, non-rechargeable batteries, damage from battery leakage, or problems arising from normal wear or failure to follow instructions.

THIS WARRANTY IS IN LIEU OF ALL OTHER WARRANTIES, EXPRESSED OR IMPLIED, INCLUDING ANY IMPLIED WARRANTY OF MERCHANTABILITY OR FITNESS FOR A PARTICULAR USE. THE REMEDIES PROVIDED HEREIN ARE BUYER'S SOLE AND EXCLUSIVE REMEDIES.

NEITHER KEITHLEY INSTRUMENTS, INC. NOR ANY OF ITS EMPLOYEES SHALL BE LIABLE FOR ANY DIRECT, INDIRECT, SPECIAL, INCIDENTAL OR CONSEQUENTIAL DAMAGES ARISING OUT OF THE USE OF ITS INSTRUMENTS AND SOFTWARE EVEN IF KEITHLEY INSTRUMENTS, INC., HAS BEEN ADVISED IN ADVANCE OF THE POSSIBILITY OF SUCH DAMAGES. SUCH EXCLUDED DAMAGES SHALL INCLUDE, BUT ARE NOT LIMITED TO: COSTS OF REMOVAL AND INSTALLATION, LOSSES SUSTAINED AS THE RESULT OF INJURY TO ANY PERSON, OR DAMAGE TO PROPERTY.

KEITHLEY

Keithley Instruments, Inc. • 28775 Aurora Road • Cleveland, OH 44139 • 216-248-0400 • Fax: 216-248-6168 • <http://www.keithley.com>

CHINA: Keithley Instruments China • Yuan Chen Xin Building, Room 705 • No. 12 Yumin Road, Dewai, Madian • Beijing, China 100029 • 8610-2022886 • Fax: 8610-2022892
FRANCE: Keithley Instruments SARL • BP 60 • 3 allée des Garays • 91122 Palaiseau Cédex • 31-6-0115155 • Fax: 31-6-0117726
GERMANY: Keithley Instruments GmbH • Landsberger Straße 65 • 82110 Germering • 49-89-849307-0 • Fax: 49-89-84930759
GREAT BRITAIN: Keithley Instruments, Ltd. • The Minster • 58 Fortman Road • Reading, Berkshire RG30 1EA • 44-01734-596666 • Fax: 44-01734-596469
ITALY: Keithley Instruments SRL • Viale S. Gimignano 38 • 20146 Milano • 39-2-48303008 • Fax: 39-2-48302274
JAPAN: Keithley KK • Aibido Bldg. • 7-20-2 Nishishinjuku • Shinjuku-ku, Tokyo 160 • 81-3-5389-1964 • Fax: 81-3-5389-2068
NETHERLANDS: Keithley Instruments BV • Avelingen West 49 • 4202 MS Gorinchem • 31-(0)183-635333 • Fax: 31-(0)183-630821
SWITZERLAND: Keithley Instruments SA • Kriesbachstrasse 4 • 8600 Dubendorf • 41-1-8219444 • Fax: 41-1-8203081
TAIWAN: Keithley Instruments Taiwan • 1, Ming-Yu First Street • Hsinchu, Taiwan, R.O.C. • 886-35-778462 • Fax: 886-35-778455

Model 7154 2-Pole High Voltage Scanner Card Instruction Manual

© 1988, Keithley Instruments, Inc.
Test Instrumentation Group
All rights reserved.
Cleveland, Ohio, U.S.A.
March 1988, First Printing
Document Number: 7154-901-01 Rev. A

SAFETY PRECAUTIONS

The following safety precautions should be observed before using this product and any associated instrumentation. Although some instruments and accessories would normally be used with non-hazardous voltages, there are situations where hazardous conditions may be present.

This product is intended for use by qualified personnel who recognize shock hazards and are familiar with the safety precautions required to avoid possible injury. Read the operating information carefully before using the product.

Exercise extreme caution when a shock hazard is present. Lethal voltage may be present on cable connector jacks or test fixtures. The American National Standards Institute (ANSI) states that a shock hazard exists when voltage levels greater than 30V RMS, 42.4V peak, or 60VDC are present. **A good safety practice is to expect that hazardous voltage is present in any unknown circuit before measuring.**

Before operating an instrument, make sure the line cord is connected to a properly grounded power receptacle. Inspect the connecting cables, test leads, and jumpers for possible wear, cracks, or breaks before each use.

For maximum safety, do not touch the product, test cables, or any other instruments while power is applied to the circuit under test. ALWAYS remove power from the entire test system and discharge any capacitors before: connecting or disconnecting cables or jumpers, installing or removing switching cards, or making internal changes, such as installing or removing jumpers.

Do not touch any object that could provide a current path to the common side of the circuit under test or power line (earth) ground. Always make measurements with dry hands while standing on a dry, insulated surface capable of withstanding the voltage being measured.

Do not exceed the maximum signal levels of the instruments and accessories, as defined in the specifications and operating information, and as shown on the instrument or test fixture rear panel, or switching card.

Do not connect switching cards directly to unlimited power circuits. They are intended to be used with impedance limited sources. NEVER connect switching cards directly to AC main. When connecting sources to switching cards, install protective devices to limit fault current and voltage to the card.

When fuses are used in a product, replace with same type and rating for continued protection against fire hazard.

Chassis connections must only be used as shield connections for measuring circuits, NOT as safety earth ground connections.

If you are using a test fixture, keep the lid closed while power is applied to the device under test. Safe operation requires the use of a lid interlock.

If a  screw is present on the test fixture, connect it to safety earth ground using #18 AWG or larger wire.

The  symbol on an instrument or accessory indicates that 1000V or more may be present on the terminals. Refer to the product manual for detailed operating information.

Instrumentation and accessories should not be connected to humans.

Maintenance should be performed by qualified service personnel. Before performing any maintenance, disconnect the line cord and all test cables.

SPECIFICATIONS

CHANNELS PER CARD: 10.

CONTACT CONFIGURATION: 2-pole Form A with user selectable shield or driven guard. Each pole is fused using No. 38 AWG magnet wire.

CONNECTOR TYPE: Screw terminals, No. 16 AWG maximum.

RELAY DRIVE CURRENT: 57mA per relay typical.

MAXIMUM SIGNAL LEVEL: 1100V peak, 0.5A rms switched, 1.0A rms carry, 10VA (resistive load only).

CONTACT LIFE: $>10^6$ closures (cold switching); $>5 \times 10^4$ closures (at maximum signal levels).

CONTACT RESISTANCE: $<200\text{m}\Omega$ initial, 2Ω to rated life.

CONTACT POTENTIAL: $<35\mu\text{V}$ per contact pair with copper leads.

ACTUATION TIME: $<2\text{ms}$, exclusive of mainframe.

CHANNEL ISOLATION: $>10^{10}\Omega$, $<10\text{pF}$.

INPUT ISOLATION:

Differential: $>10^9\Omega$, $<50\text{pF}$.

Common Mode: $>10^9\Omega$, $<150\text{pF}$.

COMMON MODE VOLTAGE: 1100V peak.

OPERATING ENVIRONMENT: 0° to 50°C ; up to 35°C at 70% R.H.

STORAGE ENVIRONMENT: -25° to $+65^\circ\text{C}$.

DIMENSIONS, WEIGHT: 32mm high x 114mm wide x 272mm long (1-1/4 in. x 4-1/2 in. x 10-3/4 in.). Net weight 0.34kg (12 oz.).

Specifications subject to change without notice.

TABLE OF CONTENTS

SECTION 1 — General Information

1.1	Introduction	1
1.2	Warranty Information	2
1.3	Manual Addenda	2
1.4	Safety Symbols and Terms	3
1.5	Unpacking and Inspection	3
1.6	Specifications	3

SECTION 2 — Operation

2.1	Introduction	5
2.2	Safety Precautions	5
2.3	Wiring	5
2.4	Installation and Removal	6
2.5	Operating Considerations	7
2.6	Applications	11
2.6.1	Shielded	11
2.6.2	Guarded	12
2.6.3	Driven Guard	12
2.6.4	4-Wire	13

SECTION 3 — Servicing Information

3.1	Introduction	17
3.2	Handling and Cleaning	17
3.3	Recommended Test Equipment	18
3.4	Contact Resistance Test	18
3.5	Isolation Tests	19
3.5.1	Channel Isolation	20
3.5.2	Input Isolation	22

SECTION 4 — Replaceable Parts

4.1	Introduction.....	25
4.2	Replaceable Parts	25
4.3	Ordering Information	25
4.4	Factory Service	25
4.5	Component Layout and Schematic Diagram.....	26

LIST OF TABLES

SECTION 3 — Servicing Information

3-1	Recommended Test Equipment	18
-----	----------------------------------	----

SECTION 4 — Replaceable Parts

4-1	Model 7154 Replaceable Parts	26
-----	------------------------------------	----

LIST OF ILLUSTRATIONS

SECTION 1 — General Information

1-1	Model 7154 Simplified Schematic	1
-----	---------------------------------------	---

SECTION 2 — Operation

2-1	Limiting Capacitive Reaction Current	9
2-2	Limiting Inductive Reaction Voltage	10
2-3	Shielded Floating Measurement	11
2-4	Guarded Floating Measurement	12
2-5	Single-Pole Switch with Switched Guard	13
2-6	Source with External Sense or Kelvin Measurement	15

SECTION 3 — Servicing Information

3-1	Contact Resistance	19
3-2	Channel Isolation	21
3-3	Input Isolation	23

SECTION 4 — Replaceable Parts

4-1	Model 7154 Component Layout	27
4-2	Model 7154 Schematic Diagram	29

SECTION 1

General Information

1.1 INTRODUCTION

The Model 7154 is a 2-pole high voltage scanner card that switches signal levels up to 1100V, 0.5A or 10VA peak (10mA at 1000V) for resistive loads only. Each of the 10 channels on the card consists of a double-pole, normally open (2-Form A) relay with a user selectable shield or driven guard connection and a fused input. The output connection and the input connections have screw terminals with a maximum allowable wire size of No. 16 AWG. A schematic representation is shown in Figure 1-1.

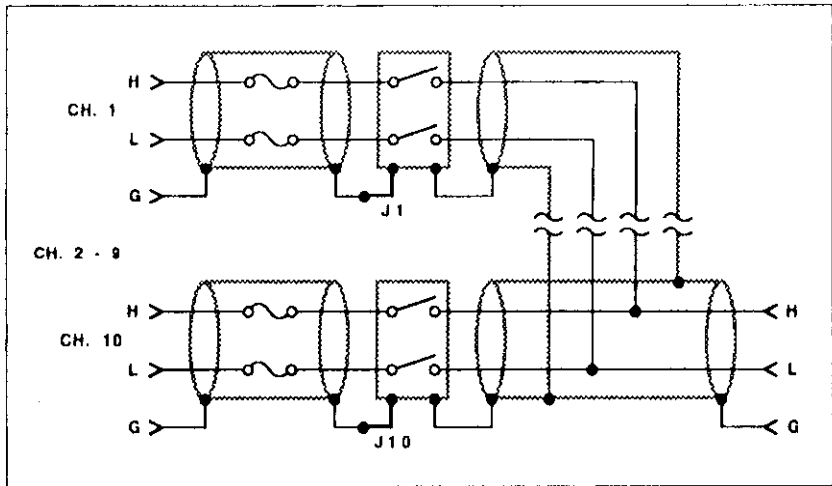

Figure 1-1. Model 7154 Simplified Schematic

Switching is done in less than 2msec exclusive of the mainframe, and the specified contact life is $>10^6$ closures with cold switching and $>10^6$ closures at maximum signal levels. The relay drive current is 57mA/relay.

The Model 7154 is field installable in an appropriate Keithley scanner mainframe (e.g. Model 705 or Model 706). With the isolation between each channel being greater than $10^{10}\Omega$ and less than 10pF, each channel is well insulated from cross channel noise and interference.

1.2 WARRANTY INFORMATION

Warranty information is stated on the inside front cover of this manual. If there is a need for service, contact the Keithley representative or authorized repair facility in your area. Check the back cover for addresses. The service form supplied at the end of the manual should be used to provide the service facility with information concerning any difficulty.

1.3 MANUAL ADDENDA

Product improvements or changes to this manual will be explained on an addendum included with the manual. It is recommended that this information be incorporated immediately into the appropriate places in the manual.

If an additional instruction manual is required, order the manual package (Keithley Part Number 7154-901-00). The manual package includes an instruction manual and all pertinent addenda.

1.4 SAFETY SYMBOLS AND TERMS

The symbol  on the card denotes that the user should refer to the operating instructions.

The symbol  denotes that a high voltage may be present on the terminals.

The **WARNING** used in this manual explains dangers that could result in personal injury or death.

The **CAUTION** used in this manual explains hazards that could damage the instrument.

1.5 UNPACKING AND INSPECTION

The Model 7154 was inspected both electrically and mechanically before shipment. Upon receiving the Model 7154, unpack all items from the shipping carton and check for any obvious damage that may have occurred during transit. Report any damage to the shipping agent. Retain and use the original packaging materials in case reshipment is necessary. The following items are shipped with every Model 7154:

Model 7154 2-Pole High Voltage Scanner Card
Model 7154 Instruction Manual

1.6 SPECIFICATIONS

Detailed specifications of the Model 7154 precede the Table of Contents of this manual.

SECTION 2

Operation

2.1 INTRODUCTION

This section provides information needed to use the Model 7154 2-Pole High Voltage Card with the Models 705 and 706 scanner mainframes. Once the card is installed in the mainframe, refer to the mainframe instruction manual for complete operating instructions.

2.2 SAFETY PRECAUTIONS

WARNING

User supplied lethal voltages may be present on the PC board or the connections. Turn off all power and discharge stored energy in external circuitry before making or breaking connections.

1. Do not exceed the Model 7154 maximum voltages of $\pm 1100\text{V}$ peak terminal to terminal and $\pm 1100\text{V}$ peak any terminal to chassis.
2. Make sure the scanner mainframe is grounded through an earth grounded receptacle before operation.
3. Inspect all test lead connections for wear and defects such as cracks and exposed wires.
4. Use appropriately rated cables when switching high voltages.

2.3 WIRING

Each channel on the Model 7154 card consists of a double-pole, normally open (2-Form A) switching relay. The Model 7154 will switch any one of the 10 signals (inputs) to one output, or switch one signal to any one of 10 outputs. See Figure 1-1.

NOTE

Because of the high impedance of the board, take special care when handling and using to prevent degradation of performance. Handle the board by the edges to avoid contaminating it with dirt, body oil, etc. For cleaning instructions, see paragraph 3.2.

1. Wiring is accomplished by means of terminal strips as shown on the component layout (see Figure 4-1). Each channel has a HI connection, LO connection, and GUARD connection. Guard is common to all channels with the jumpers (W1-W10) installed. The Model 7154 is shipped with all jumpers installed.
2. Resistance of the relay contacts path is less than 0.2Ω .
3. A common guard surrounds all analog signal paths.
4. Use wires or cables that are rated for greater than 1100V. The maximum allowable wire size is No. 16 AWG. The minimum wire size is No. 26 AWG.
5. Route the wires through the rubber clamp pads located at the rear of the card.

2.4 INSTALLATION AND REMOVAL

Once the card is wired, insert it card-edge first into the scanner mainframe by aligning it with the grooves in the appropriate slot. Make sure it is properly seated into the mainframe connector. Push the locking tabs forward to the center of the card to lock it in.

To remove a card, first turn off the mainframe and all other equipment connected to the card. Unfasten the locking tabs on the card by pulling the tabs outward. Grasp the end of the card and carefully pull it out of the mainframe.

2.5 OPERATING CONSIDERATIONS

Since the Model 7154 is a 10-channel card, set the scanner to the 2-pole mode when using the Model 7154 by itself or when intermixing with other 10-channel cards. In the 2-pole scanner mode, each scanner channel controls one channel on one 10-channel card.

The 4-pole mode of operation will be discussed in Section 2.6

Signal Levels—The maximum signal levels for the Model 7154 2-Pole High Voltage Card are 1100V maximum, 0.5A or 10VA peak for resistive loads only. The specified contact life is $>10^8$ closures with cold switching and $>10^6$ closures at maximum signal levels.

WARNING

When switching signals greater than 30V RMS or 42.2V peak take care to prevent contact with live circuits which could cause electrical shock resulting in injury or death.

Cables—Shielded cables should be used with the Model 7154 card when switching above 50V. The shield should be connected to the circuit LO or GUARD. This prevents excessive radiation from the cables from interfering with any equipment. The cables must be rated for greater than 1100V.

Fusible Links—The Model 7154 scanner card has a fusible link (SQ1-SQ20) in series with the high and low input side of each channel's relay. A link opens when the current level on that channel becomes excessive because of an external circuit misapplication or a relay failure. The links protect the PC board from damage that is difficult to repair (e.g. lifted or burned traces on the board).

A repair procedure for the links follows:

1. Clean out the PC board feedthru holes for the fusible link with a desoldering tool.

2. Insert a jumper of No. 38 AWG magnet wire into the holes and solder in place.

CAUTION

This wire must be taut to maintain voltage spacing.

CAUTION

When replacing the fusible links, use only No. 38 AWG magnet wire. Use of any other wire may cause severe damage to the PC board.

3. Check the same channel's relay contacts for a short or insufficient input isolation resistance and replace the relay if necessary. See Sections 3 and 4.
4. Clean the PC board according to the instructions given in paragraph 3.2.

Depending on your application, a current limiting resistor can be used in place of a fusible link. Each resistor will limit the current flow through one side (HI or LO) of one channel. The resistors must be of sufficient power rating to safely dissipate any overload.

Reactive Loads—The Model 7154 is specified for resistive loads only. Since reactive loads can cause excessive currents and voltages, current surge limiting (for capacitive loads) and voltage clamping (for inductive loads) are required to prevent damaging the relays and external circuitry.

1. Capacitive Loads - The surge current from a capacitive load must be less than 0.5A to protect the relays. Figure 2-1 shows typical circuits to limit current surges. Also, consider the maximum load of 10VA when determining the current limit. For example, when switching 500V, the current must be limited to 20mA ($I = 10VA/500V$) and the limiting resistor calculation of Figure 2-1A would be:

$$R = V/I = 500V/20mA = 25k\Omega$$

2. Inductive Loads - Inductive reaction voltage, $L(di/dt)$, must be less than 1100V. Typical clamping circuits are shown in Figure 2-2. Also, consider the maximum load of 10VA when determining the voltage limit. For example, when switching 40mA, the voltage must be limited to 250V ($V = 10VA/40mA$) and the clamping resistor calculation of Figure 2-2A would be:

$$R = V/I = 250V/40mA = 6250\Omega$$

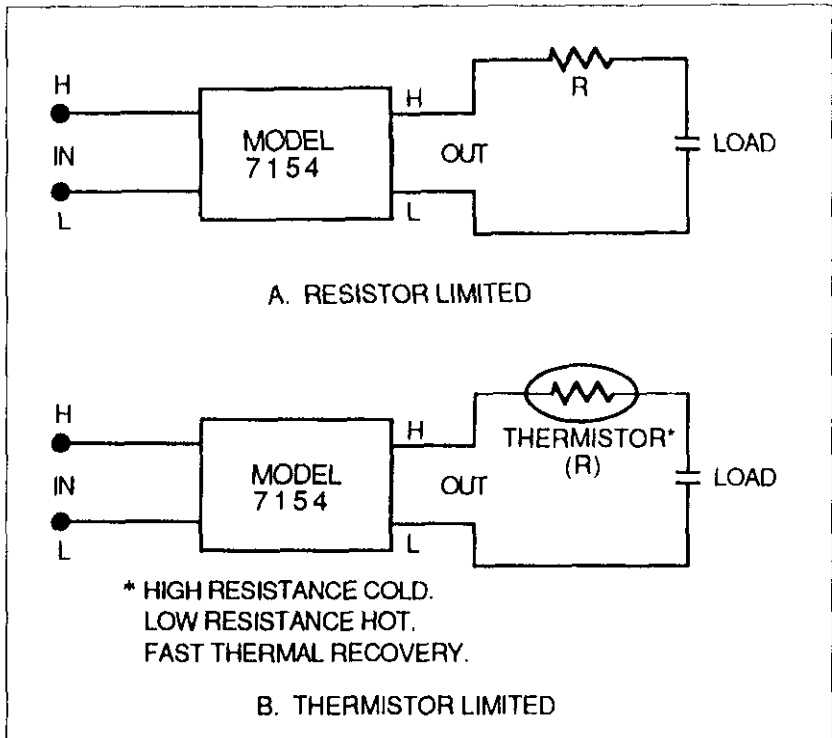
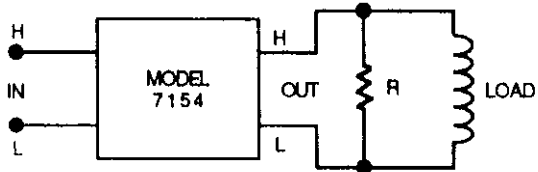
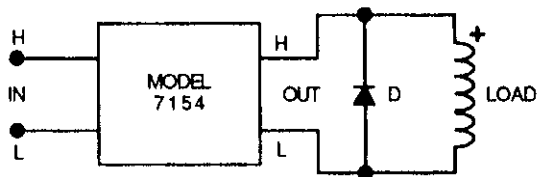

Figure 2-1. Limiting Capacitive Reaction Current



A. RESISTOR CLAMPED (AC OR DC VOLTAGES)



B. DIODE CLAMPED (DC VOLTAGES)

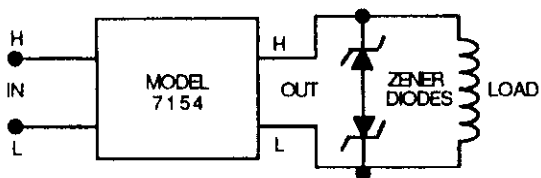

C. ZENER CLAMPED (AC VOLTAGES)

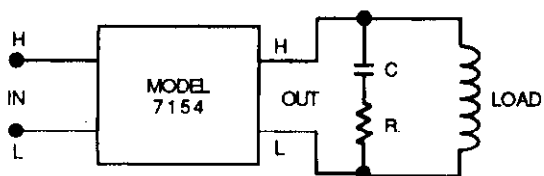

D. RESISTOR-CAPACITOR CLAMPED (AC VOLTAGES)

Figure 2-2. Limiting Inductive Reaction Voltage

2.6 APPLICATIONS

The Model 7154 can monitor high voltages from 10 different devices under test (DUT), switch a high voltage source to 10 separate DUTs, or connect multiple DUTs to multiple sources.

2.6.1 Shielded

CAUTION

This application is one channel at a time. Due to the possibility of high voltage, be sure to break one connection before connecting another or the card could be damaged.

The measurement scheme shown in Figure 2-3 is used to make a shielded floating measurement on up to 10 DUTs with one meter. The guard traces are used as a shield, so they are connected to the meter's LO. If both GUARD pins can not be kept at the same potential, remove the jumper.

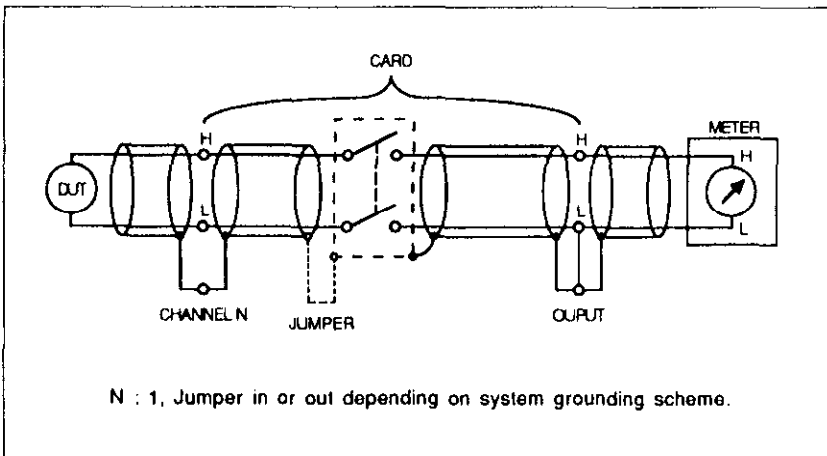

Figure 2-3. Shielded Floating Measurement

2.6.2 Guarded

Non-driven guarded measurements are made with the set up shown in Figure 2-4. The jumper is installed to provide a guard which completely encloses high and low. This guards them from other channels on the card for improved channel isolation.

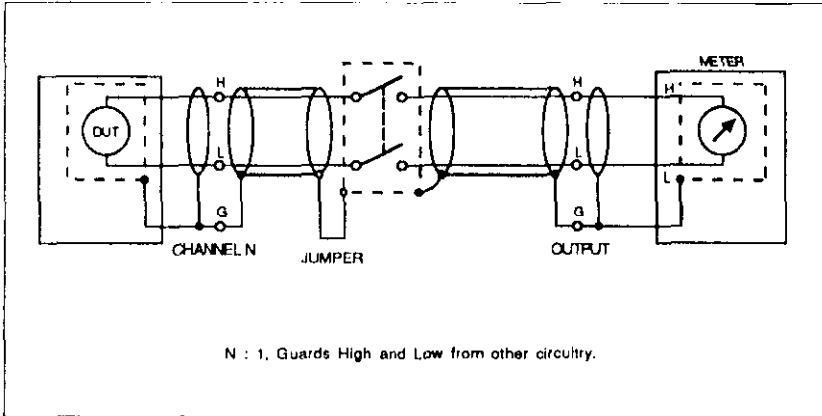

Figure 2-4. Guarded Floating Measurement

2.6.3 Driven Guard

If multiple sources are switched to a DUT using a driven guard, as shown in Figure 2-5A, the guard must be switched. The jumper for each channel in use is removed so that the various sources will not try to drive other guards. Instrument LO is not switched or is switched by another card for both Figures 2-5A and 2-5B.

LO and GUARD are shorted at both ends of the signal path to allow for the switched guard. Low for the source(s) and DUT must be a connection made externally.

Figure 2-5B is the same configuration for connecting one source to multiple DUTs. In this case, the jumper is removed to reduce the capacitive loading on the guard.

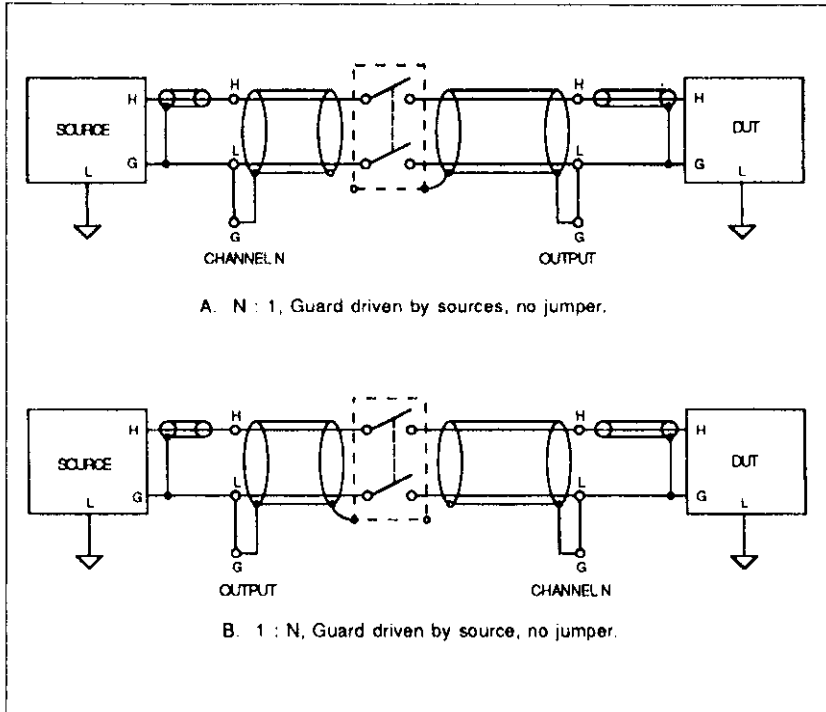

Figure 2-5. Single-Pole Switch with Switched Guard

2.6.4 4-Wire

Connecting multiple DUTs to one instrument using either a Kelvin technique or external sense as with a Source Measure Unit (SMU), requires two cards operating in 4-pole mode. This is shown in Figure 2-6.

HI and Sense HI are switched through one card. The jumper is installed to provide a guard all the way to the DUT. Since this is a driven guard, it is connected only to the guard of the instrument and not terminated at the DUT.

LO and Sense LO are switched through the second card. The jumper is installed to provide shielding for these lines. The shield on the cabling should cover as much of the signal lines as possible, and should be terminated only at the instrument. Shields are typically at circuit low or earth.

This configuration combines sense and Kelvin configurations so that guard on the card is driven for the High leads and is a shield for the Low leads.

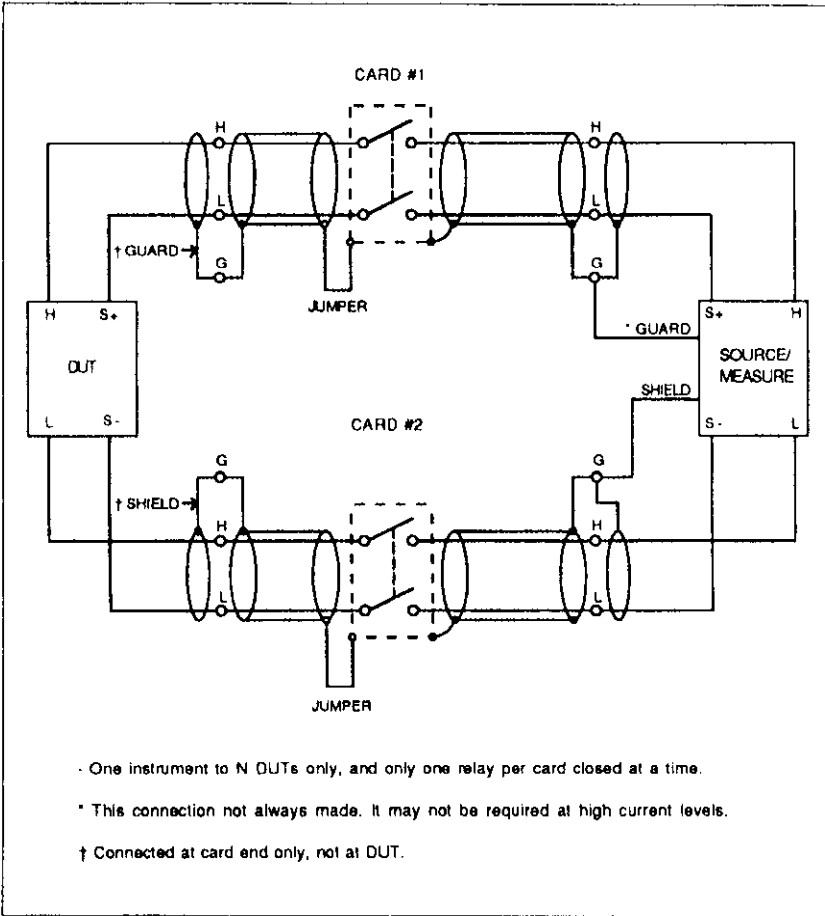

Figure 2-6. Source with External Sense or Kelvin Measurement

SECTION 3

Servicing Information

3.1 INTRODUCTION

This section describes tests for verifying the performance of the Model 7154. The tests include:

- **Functionality test** - Measuring contact resistance to check for open or shorted relays or bad connections.
- **Specification tests** - Two isolation tests measuring leakage currents to check for a contaminated board and possibly bad relays.

Perform these tests in an environment within the specified operating temperature range (0° to 35°C up to 70% RH) of the scanner card.

WARNING

Do not perform the procedures in this section unless you are a qualified service person. Some of the procedures may expose you to potentially lethal voltages (>30V RMS) that could result in personal injury or death if normal safety precautions are not observed.

Recommended maintenance includes inspection of the scanner card and the card edge connector to ensure good electrical contact. The Model 7154 does not require calibration.

3.2 HANDLING AND CLEANING

Because of the high impedance of the board, take special care when handling and using to prevent degradation of performance. Handle the board by the edges to avoid contaminating it with dirt, body oil, etc.

To clean the board, spray on an uncontaminated solvent, such as Freon® TMS or TE and clean with cotton swabs or a soft brush. After the solvent has been applied and is still liquid, blow-dry the board with dry nitrogen gas.

3.3 RECOMMENDED TEST EQUIPMENT

Table 3-1 lists recommended test equipment for performance verification. Other test equipment may be substituted if specifications equal or exceed those stated.

NOTE

The Model 617 electrometer has an internal 100V source. If the Model 617 is used, its internal voltage can be used in place of the Model 230 Voltage Source.

Table 3-1. Recommended Test Equipment

Description	Specification	Mfr.	Model
Scanner Mainframe	--	Keithley	705 or 706
Extender Card	—	Keithley	7061
DMM	< 0.1Ω sensitivity	Keithley	196
Voltage Source	100VDC	Keithley	230
Electrometer	10 ⁻¹⁰ A	Keithley	614 or 617

3.4 CONTACT RESISTANCE TEST

This test measures the resistance of each relay contact in an opened and closed state.

1. Set up the equipment as shown in Figure 3-1. Short the HI terminal to the LO terminal of each channel. Attach two copper wires to the output HI and LO terminals.
2. Zero the Model 196 with the Kelvin test leads shorted together.

3. Set the channel mainframe to the channel mode, channel 1, and the step mode. Close channel 1 from the scanner front panel. The reading on the Model 196 should indicate a short circuit (less than 0.2Ω).
4. Open channel 1 from the scanner front panel. The reading on the Model 196 should indicate an open circuit ($> 300M\Omega$).
5. Repeat steps 3 and 4 for the remaining channels on the card.

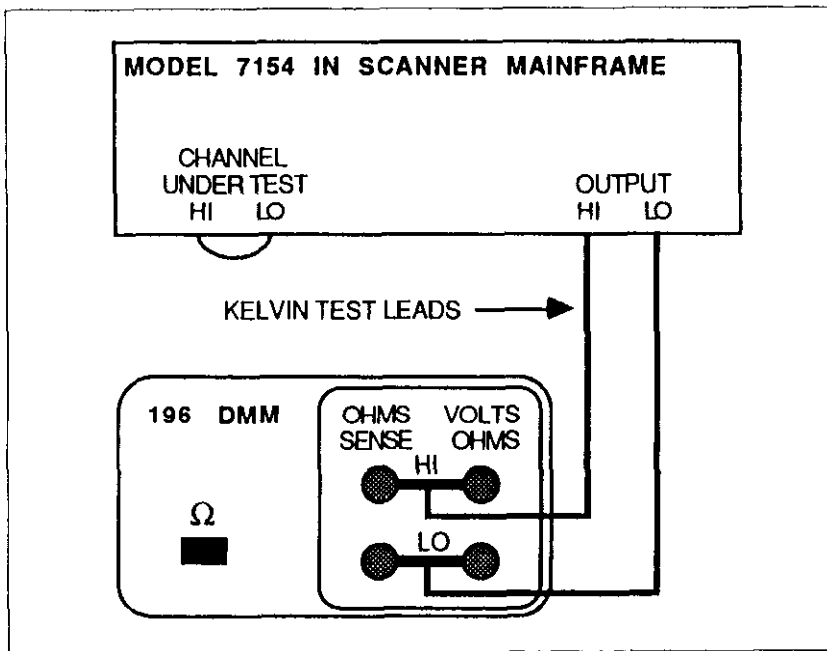

Figure 3-1. Contact Resistance

3.5 ISOLATION TESTS

The two isolation tests measure leakage currents for calculating leakage resistances on the Model 7154. With the Model 7061 Universal Adapter Card, these tests can be performed faster.

3.5.1 Channel Isolation

This test measures the leakage current between two channels.

1. Set up the equipment as shown in Figure 3-2.
2. Set the scanner to channel 1 and the step mode. Program channel 1 open and the other channels as closed.

CAUTION

Make sure the channel under test is OPEN. Failure to do this can cause damage to the instrument.

3. Set the electrometer to amps and zero check. Program the Model 230 to output 100V. Take the electrometer out of zero check.
4. The electrometer should read less than 10^{-8} A. (Due to the capacitance of the circuit, the offset current may be high until the circuit capacitance is charged up. Wait until the readings settle out.)
5. Using Ohm's law, calculate the channel isolation (the leakage resistance between two channels). For example:

$$R = E/I = 100V/10^{-8}A = 10^{10}\Omega$$

NOTE

With the Model 617 electrometer in V/I mode, the resistance is calculated automatically.

6. Put the Model 230 in standby mode and set the electrometer to zero.
7. Repeat steps 2 through 6 for the remaining channels.

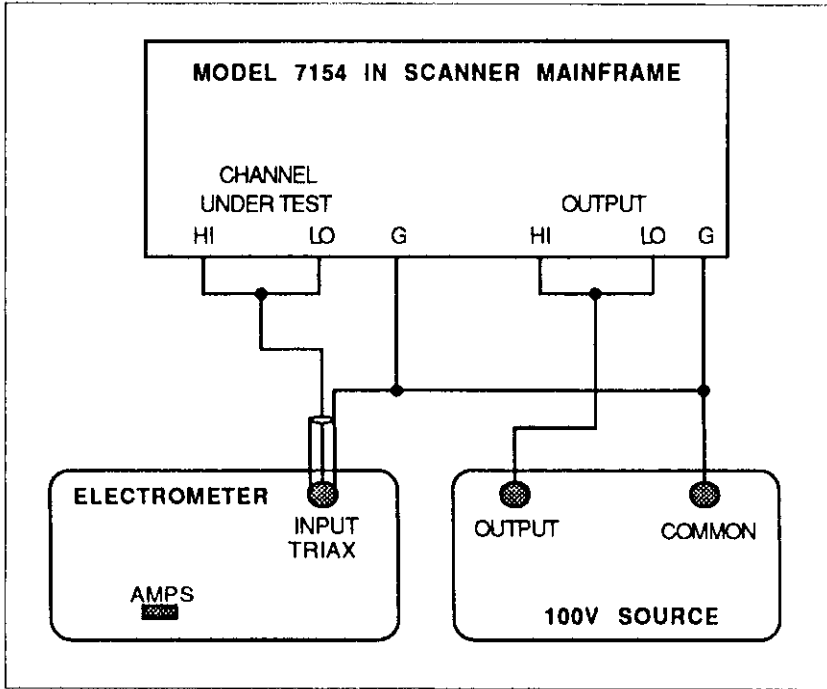

Figure 3-2. Channel Isolation

3.5.2 Input Isolation

This test measures the leakage current between a channel's HI and LO terminals.

1. Set up the equipment as shown in Figure 3-3.
2. Set the scanner to channel 1 and the step mode. Close channel 1 and open all other channels.
3. Set the electrometer to amps and zero check. Program the Model 230 to output 100V. Take the electrometer out of zero check.
4. The electrometer should read less than 10^{-7} A. (Due to the capacitance of the circuit, the offset current may be high until the circuit capacitance is charged up. Wait until the readings settle out.)
5. Using Ohm's law, calculate the input isolation (leakage resistance) for this channel. For example:

$$R = E/I = 100V/10^{-7}A = 10^9\Omega.$$

NOTE

With the Model 617 electrometer in V/I mode, the resistance is calculated automatically.

6. Put the Model 230 in standby mode and set the electrometer to zero.
7. Repeat steps 2 through 6 for the remaining channels.

NOTE

For all other channels, the channel under test should be closed and all other channels open.

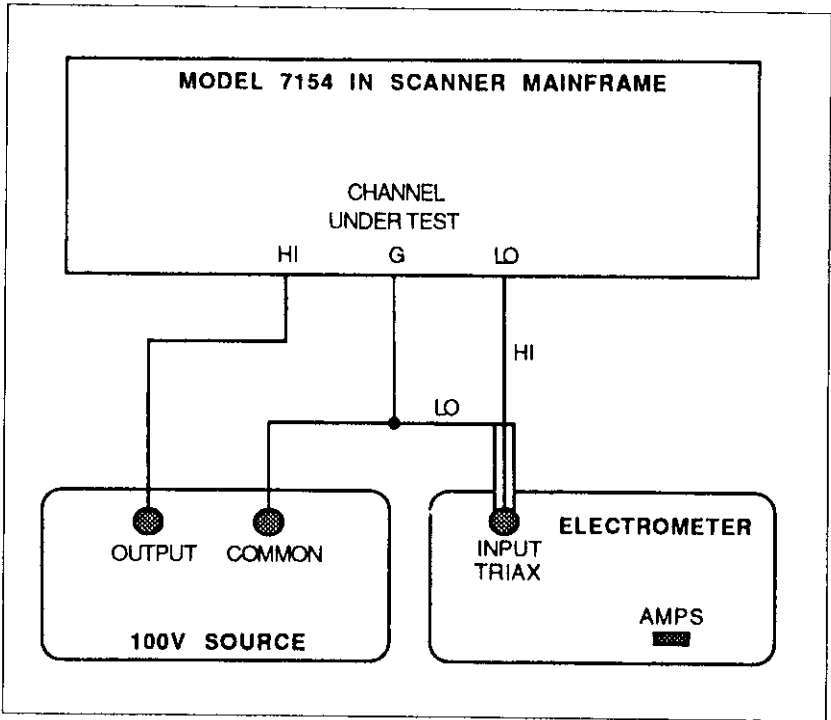

Figure 3-3. Input Isolation

SECTION 4

Replaceable Parts

4.1 INTRODUCTION

This section contains replacement parts information, a component layout, and a schematic diagram for the Model 7154.

4.2 REPLACEABLE PARTS

Table 4-1 lists parts alphanumerically in the order of their circuit designations.

4.3 ORDERING INFORMATION

To place an order or to obtain information about replacement parts, contact your Keithley representative or the factory. See the back cover for addresses. When ordering, include the following information:

- Model number
- Serial number
- Part description
- Circuit description (if applicable)
- Keithley part number

4.4 FACTORY SERVICE

If the scanner card is to be returned to Keithley Instruments for repair, perform the following:

1. Photocopy and complete the service form at the back of this manual and include it with the card.

2. Carefully pack the card in the original packing carton.
3. Write ATTENTION REPAIR DEPARTMENT on the shipping label.

Note that it is not necessary to return the scanner mainframe with the card.

4.5 COMPONENT LAYOUT AND SCHEMATIC DIAGRAM

Figure 4-1 shows a component layout of the Model 7154. Figure 4-2 shows the schematic diagram of the Model 7154.

Table 4-1. Model 7154 Replaceable Parts

Circuit Desig.	Description	Keithley Part No.
C1	Capacitor, 10 μ F, 25V, Aluminum	C-314-10
C2	Capacitor, 0.1 μ F, 50V, Ceramic	C-365-.1
C3- C12	Capacitor, 0.01 μ F, 50V, Ceramic	C-365-.01
E1	Ferrite Bead	CT-9
J5, J6 J7	Connector Connector	CS-464-4 CS-464-3
K1-K10	Relay, 2-Form A	RL-118
SQ1- SQ20	Fusible Link, No. 38 AWG Magnet Wire	—
W1- W10	Jumper	J3
	Upper Clamp Assembly	7055-303-15
	Lower Clamp Assembly	7055-308

LTR. ECD NO.	REVISION	ENG. DATE
B	12485 RELEASED	SE 11/25/87
C	15679 PARTS: #88 REV B, #800D #11 (SC-100-2)	JA 4/23/93

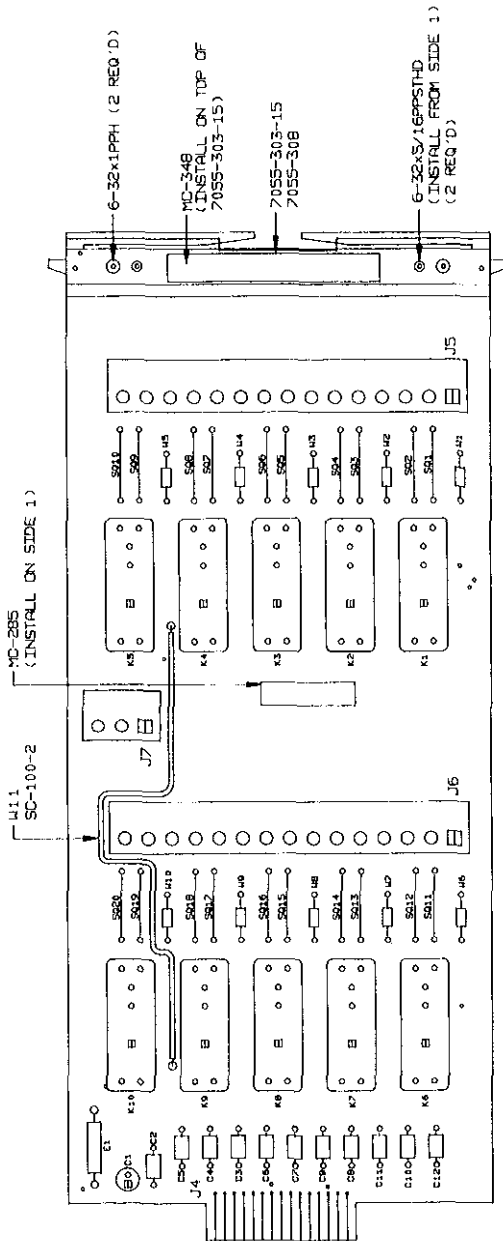

Figure 4-1. Model 7154 Component Layout

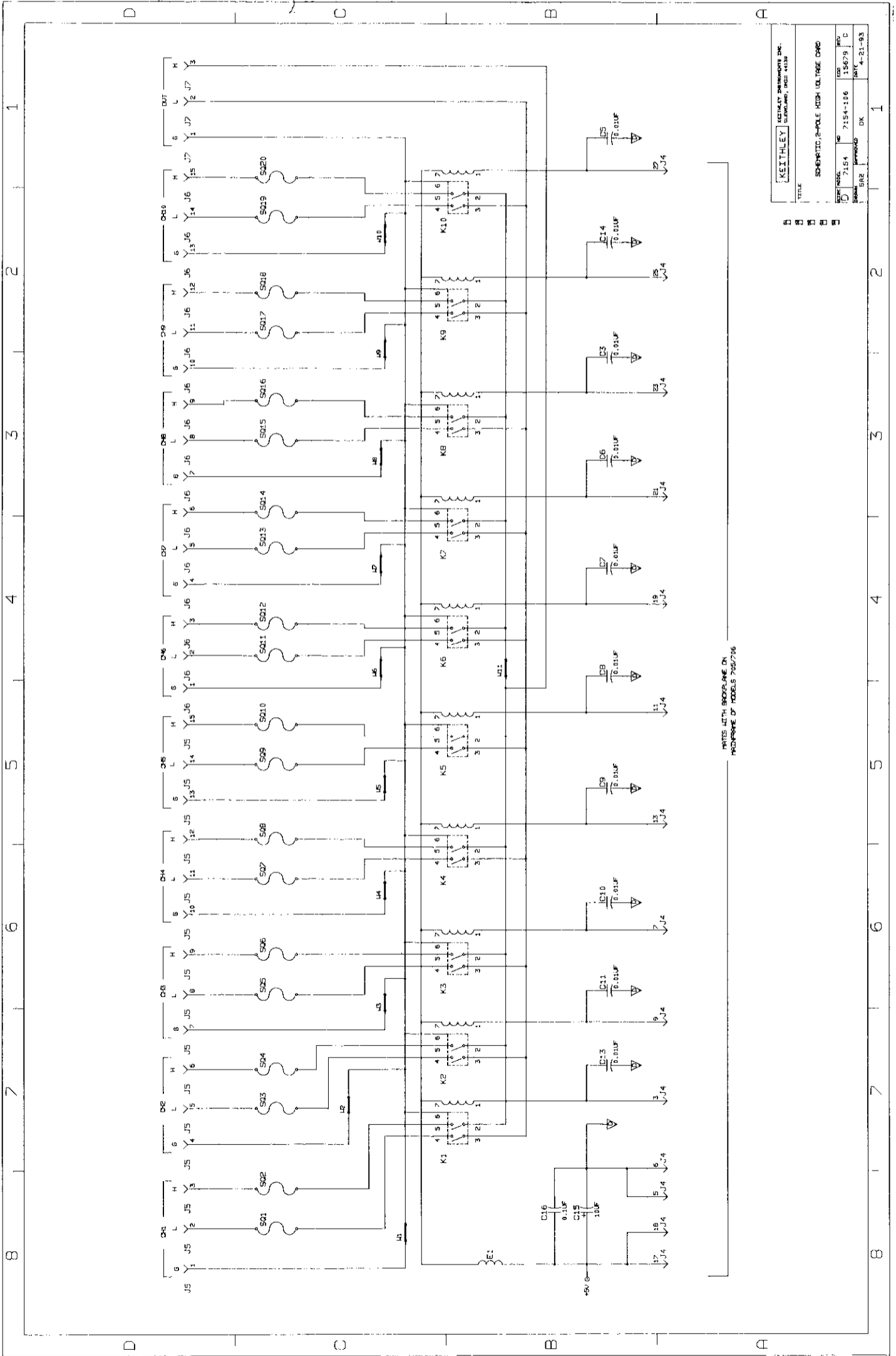

Figure 4-2.
Model 7154
Schematic Diagram



Service Form

Model No. _____ Serial No. _____ Date _____

Name and Telephone No. _____

Company _____

List all control settings, describe problem and check boxes that apply to problem. _____

- | | | |
|--|--|--|
| <input type="checkbox"/> Intermittent | <input type="checkbox"/> Analog output follows display | <input type="checkbox"/> Particular range or function bad; specify _____ |
| <input type="checkbox"/> IEEE failure | <input type="checkbox"/> Obvious problem on power-up | <input type="checkbox"/> Batteries and fuses are OK |
| <input type="checkbox"/> Front panel operational | <input type="checkbox"/> All ranges or functions are bad | <input type="checkbox"/> Checked all cables |

Display or output (check one)

- | | |
|---|--|
| <input type="checkbox"/> Drifts | <input type="checkbox"/> Unable to zero |
| <input type="checkbox"/> Unstable | <input type="checkbox"/> Will not read applied input |
| <input type="checkbox"/> Overload | |
| <input type="checkbox"/> Calibration only | <input type="checkbox"/> Certificate of calibration required |
| <input type="checkbox"/> Data required | |

(attach any additional sheets as necessary)

Show a block diagram of your measurement system including all instruments connected (whether power is turned on or not). Also, describe signal source.

Where is the measurement being performed? (factory, controlled laboratory, out-of-doors, etc.)

What power line voltage is used? _____ Ambient temperature? _____ °F

Relative humidity? _____ Other? _____

Any additional information. (If special modifications have been made by the user, please describe.)

Be sure to include your name and phone number on this service form.

KEITHLEY

Keithley Instruments, Inc.
Test Instrumentation Group
28775 Aurora Road
Cleveland, Ohio 44139

Printed in the U.S.A.

www.valuetronics.com