

Model 7116-MWS
Microwave Switch System
Instruction Manual

Contains Operating and Servicing Information

KEITHLEY

WARRANTY

Keithley Instruments, Inc. warrants this product to be free from defects in material and workmanship for a period of 1 year from date of shipment.

Keithley Instruments, Inc. warrants the following items for 90 days from the date of shipment: probes, cables, rechargeable batteries, diskettes, and documentation.

During the warranty period, we will, at our option, either repair or replace any product that proves to be defective.

To exercise this warranty, write or call your local Keithley representative, or contact Keithley headquarters in Cleveland, Ohio. You will be given prompt assistance and return instructions. Send the product, transportation prepaid, to the indicated service facility. Repairs will be made and the product returned, transportation prepaid. Repaired or replaced products are warranted for the balance of the original warranty period, or at least 90 days.

LIMITATION OF WARRANTY

This warranty does not apply to defects resulting from product modification without Keithley's express written consent, or misuse of any product or part. This warranty also does not apply to fuses, software, non-rechargeable batteries, damage from battery leakage, or problems arising from normal wear or failure to follow instructions.

THIS WARRANTY IS IN LIEU OF ALL OTHER WARRANTIES, EXPRESSED OR IMPLIED, INCLUDING ANY IMPLIED WARRANTY OF MERCHANTABILITY OR FITNESS FOR A PARTICULAR USE. THE REMEDIES PROVIDED HEREIN ARE BUYER'S SOLE AND EXCLUSIVE REMEDIES.

NEITHER KEITHLEY INSTRUMENTS, INC. NOR ANY OF ITS EMPLOYEES SHALL BE LIABLE FOR ANY DIRECT, INDIRECT, SPECIAL, INCIDENTAL OR CONSEQUENTIAL DAMAGES ARISING OUT OF THE USE OF ITS INSTRUMENTS AND SOFTWARE EVEN IF KEITHLEY INSTRUMENTS, INC., HAS BEEN ADVISED IN ADVANCE OF THE POSSIBILITY OF SUCH DAMAGES. SUCH EXCLUDED DAMAGES SHALL INCLUDE, BUT ARE NOT LIMITED TO: COSTS OF REMOVAL AND INSTALLATION, LOSSES SUSTAINED AS THE RESULT OF INJURY TO ANY PERSON, OR DAMAGE TO PROPERTY.

KEITHLEY

Keithley Instruments, Inc. • 28775 Aurora Road • Cleveland, OH 44139 • 440-248-0400 • Fax: 440-248-6168 • <http://www.keithley.com>

CHINA: Keithley Instruments China • Yuan Chen Xin Building, Room 705 • 12 Yumin Road, Dewai, Madian • Beijing 100029 • 8610-62022886 • Fax: 8610-62022892
FRANCE: Keithley Instruments SARL • BP 60 • 3 Allée des Garays • 91122 Palaiseau Cédex • 33-1-60-11-51-55 • Fax: 33-1-60-11-77-26
GERMANY: Keithley Instruments GmbH • Landsberger Strasse 65 • D-82110 Germering, Munich • 49-89-8493070 • Fax: 49-89-84930759
GREAT BRITAIN: Keithley Instruments, Ltd. • The Minster • 58 Portman Road • Reading, Berkshire RG30 1EA • 44-1189-596469 • Fax: 44-1189-575666
ITALY: Keithley Instruments SRL • Viale S. Gimignano 38 • 20146 Milano • 39-2-48303008 • Fax: 39-2-48302274
NETHERLANDS: Keithley Instruments BV • Avelingen West 49 • 4202 MS Gorinchem • 31-(0)183-635333 • Fax: 31-(0)183-630821
SWITZERLAND: Keithley Instruments SA • Kriesbachstrasse 4 • 8600 Dübendorf • 41-1-8219444 • Fax: 41-1-8203081
TAIWAN: Keithley Instruments Taiwan • 1FL., 85 Po Ai Street • Hsinchu, Taiwan • 886-3-572-9077 • Fax: 886-3-572-9031

Model 7116-MWS 16-Channel Microwave Switch System Instruction Manual

©1996, Keithley Instruments, Inc.
All rights reserved.
Cleveland, Ohio, U.S.A.
Third Printing, July 1998
Document Number: 7116MWS-901-01 Rev. C

Manual Print History

The print history shown below lists the printing dates of all Revisions and Addenda created for this manual. The Revision Level letter increases alphabetically as the manual undergoes subsequent updates. Addenda, which are released between Revisions, contain important change information that the user should incorporate immediately into the manual. Addenda are numbered sequentially. When a new Revision is created, all Addenda associated with the previous Revision of the manual are incorporated into the new Revision of the manual. Each new Revision includes a revised copy of this print history page.

Revision A (Document Number 7116MWS-901-01)	August 1996
Revision B (Document Number 7116MWS-901-01)	November 1996
Revision C (Document Number 7116MWS-901-01)	July 1998

All Keithley product names are trademarks or registered trademarks of Keithley Instruments, Inc.
Other brand and product names are trademarks or registered trademarks of their respective holders.

Safety Precautions

The following safety precautions should be observed before using this product and any associated instrumentation. Although some instruments and accessories would normally be used with non-hazardous voltages, there are situations where hazardous conditions may be present.

This product is intended for use by qualified personnel who recognize shock hazards and are familiar with the safety precautions required to avoid possible injury. Read the operating information carefully before using the product.

The types of product users are:

Responsible body is the individual or group responsible for the use and maintenance of equipment, and for ensuring that operators are adequately trained.

Operators use the product for its intended function. They must be trained in electrical safety procedures and proper use of the instrument. They must be protected from electric shock and contact with hazardous live circuits.

Maintenance personnel perform routine procedures on the product to keep it operating, for example, setting the line voltage or replacing consumable materials. Maintenance procedures are described in the manual. The procedures explicitly state if the operator may perform them. Otherwise, they should be performed only by service personnel.

Service personnel are trained to work on live circuits, and perform safe installations and repairs of products. Only properly trained service personnel may perform installation and service procedures.

Exercise extreme caution when a shock hazard is present. Lethal voltage may be present on cable connector jacks or test fixtures. The American National Standards Institute (ANSI) states that a shock hazard exists when voltage levels greater than 30V RMS, 42.4V peak, or 60VDC are present. **A good safety practice is to expect that hazardous voltage is present in any unknown circuit before measuring.**

Users of this product must be protected from electric shock at all times. The responsible body must ensure that users are prevented access and/or insulated from every connection point. In some cases, connections must be exposed to potential human contact. Product users in these circumstances must be trained to protect themselves from the risk of electric shock. If the circuit is capable of operating at or above 1000 volts, **no conductive part of the circuit may be exposed.**

As described in the International Electrotechnical Commission (IEC) Standard IEC 664, digital multimeter measuring circuits (e.g., Keithley Models 175A, 199, 2000, 2001, 2002, and 2010) are Installation Category II. All other instruments' signal terminals are Installation Category I and must not be connected to mains.

Do not connect switching cards directly to unlimited power circuits. They are intended to be used with impedance limited sources. NEVER connect switching cards directly to AC mains. When connecting sources to switching cards, install protective devices to limit fault current and voltage to the card.

Before operating an instrument, make sure the line cord is connected to a properly grounded power receptacle. Inspect the connecting cables, test leads, and jumpers for possible wear, cracks, or breaks before each use.

For maximum safety, do not touch the product, test cables, or any other instruments while power is applied to the circuit under test. ALWAYS remove power from the entire test system and discharge any capacitors before: connecting or disconnecting cables or jumpers, installing or removing switching cards, or making internal changes, such as installing or removing jumpers.

Do not touch any object that could provide a current path to the common side of the circuit under test or power line (earth) ground. Always make measurements with dry hands while standing on a dry, insulated surface capable of withstanding the voltage being measured.

Do not exceed the maximum signal levels of the instruments and accessories, as defined in the specifications and operating information, and as shown on the instrument or test fixture panels, or switching card.

When fuses are used in a product, replace with same type and rating for continued protection against fire hazard.

Chassis connections must only be used as shield connections for measuring circuits, NOT as safety earth ground connections.

If you are using a test fixture, keep the lid closed while power is applied to the device under test. Safe operation requires the use of a lid interlock.

If a  screw is present, connect it to safety earth ground using the wire recommended in the user documentation.

The  symbol on an instrument indicates that the user should refer to the operating instructions located in the manual.

The  symbol on an instrument shows that it can source or measure 1000 volts or more, including the combined effect of normal and common mode voltages. Use standard safety precautions to avoid personal contact with these voltages.

The **WARNING** heading in a manual explains dangers that might result in personal injury or death. Always read the associated information very carefully before performing the indicated procedure.

The **CAUTION** heading in a manual explains hazards that could damage the instrument. Such damage may invalidate the warranty.

Instrumentation and accessories shall not be connected to humans.

Before performing any maintenance, disconnect the line cord and all test cables.

To maintain protection from electric shock and fire, replacement components in mains circuits, including the power transformer, test leads, and input jacks, must be purchased from Keithley Instruments. Standard fuses, with applicable national safety approvals, may be used if the rating and type are the same. Other components that are not safety related may be purchased from other suppliers as long as they are equivalent to the original component. (Note that selected parts should be purchased only through Keithley Instruments to maintain accuracy and functionality of the product.) If you are unsure about the applicability of a replacement component, call technical support for information.

To clean the instrument, use a damp cloth or mild, water based cleaner. Clean the exterior of the instrument only. Do not apply cleaner directly to the instrument or allow liquids to enter or spill on the instrument.

Table of Contents

1 Installation

Introduction	1-1
7116-MWS installation instructions	1-1
Parts list	1-2
Rack preparation	1-2
System installation	1-3
System earth ground installation	1-3
Semi-rigid coax cable installation	1-4

2 Operation

Introduction	2-1
Operating instructions	2-2
7020-MWS configuration	2-3

3 Service

Introduction	3-1
Troubleshooting	3-1
Troubleshooting equipment	3-1
Troubleshooting procedure	3-1
Ordering information	3-2
Factory service	3-2
Engineering drawings	3-2

List of Illustrations

1 Installation

Figure 1-1	Fastener installation	1-2
Figure 1-2	Mounting kit installation	1-3
Figure 1-3	Cable installation	1-4

2 Operation

Figure 2-1	Tree switching network	2-1
------------	------------------------------	-----

List of Tables

1 Installation

Table 1-1	Model 7116-MWS rack assembly parts	1-2
-----------	--	-----

2 Operation

Table 2-1	Model 7001 outputs, memory locations, and commands	2-2
-----------	--	-----

3 Service

Table 2-1	Troubleshooting procedure	3-2
-----------	---------------------------------	-----

1

Installation

Introduction

The Model 7116-MWS 16-Channel Microwave Switch System provides an integrated solution for multiplexed signal routing of microwave signals at frequencies up to 18GHz. The Model 7116-MWS switch system can be used to test wireless telecommunication devices and systems such as cellular phones, cordless phones, pagers, antenna systems, base stations, and other wireless transmission productions.

It consists of:

- Five 1×4 microwave RF multiplexer switch modules
- A Model 7020-MWS switching card
- A Model 7001 switching mainframe
- An off-line power supply
- Semi-rigid cables

7116-MWS installation instructions

WARNING

The information on the following pages is intended for qualified service personnel only. Do not attempt these procedures unless you are qualified to do so.

CAUTION

To prevent flexing of the connections and possible damage, ensure that the Model 7020-MWS card is secured with its thumbscrew to the Model 7001 rear panel, and that the cable assembly is secured with its two screws to the 7020-MWS card.

Table 1-1
 Model 7116-MWS rack assembly parts

Quantity	Description	Keithley part number	Function
2	Bracket, rear support	BR-21	Attaches chassis rear to rear rack rails.
4	10-32 Kepnut	10-32 KEPNUT	Attaches rear support brackets to chassis.
4	10-32 × 3/8 Phillips pan head screw	10-32x3/8 PPH	
8	Fastener, captive nut	FA-148	Attaches rear support brackets and front panel to rails.
8	10-32 × 5/8 Phillips pan head screw	10-32x5/8 PPH	
1	10-32 × 3/8 Phillips pan head sems screw	10-32x3/8 PPHSEM	Connect ground cable to earth ground.
2	Semi-rigid cable	7116-307-1	
2	Semi-rigid cable	7116-307-2	

Parts list

Table 1-1 lists the parts supplied with the Model 7116-MWS 16-Channel Microwave Switch System.

Rack preparation

1. Select a location in the rack. The assembly will take up to 5¼ inches of vertical space.
2. Hold up the system at the selected location in the rack. The four slotted mounting holes in the front panel dictate the location of the captive nut fasteners on the front rack rails. Mark where the fasteners are to be installed.
3. Referring to Figure 1-1, install four fasteners so the captive nuts are located behind the appropriate holes on the front rack rails.

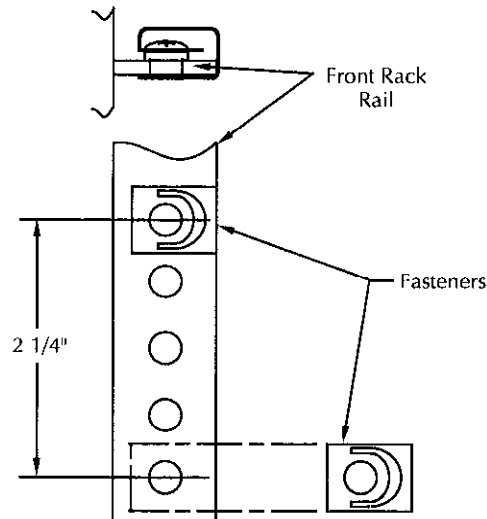

Figure 1-1
 Fastener installation

System installation

Refer to Figure 1-2 to install the chassis and support brackets in the rack.

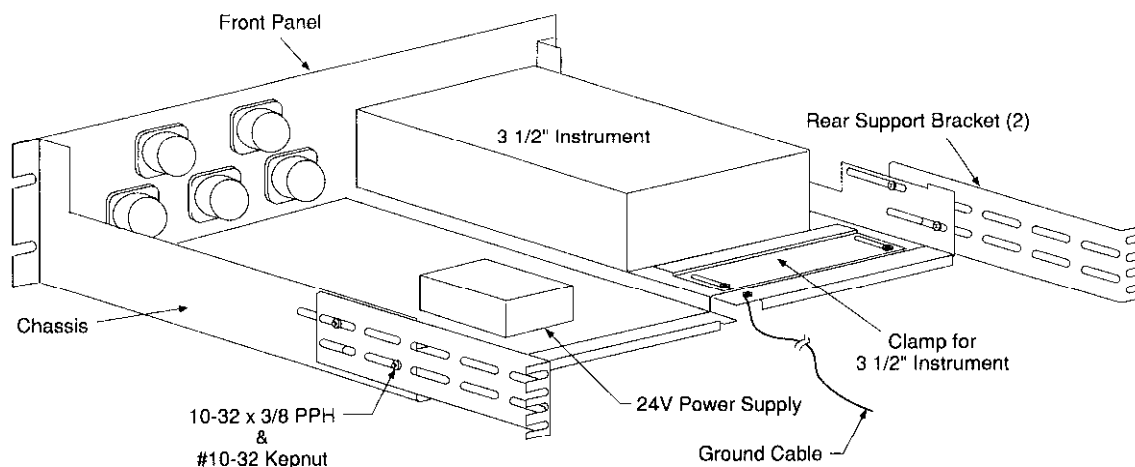

Figure 1-2
Mounting kit installation

1. Loosely attach the rear support brackets to the chassis with kepnuts and 10-32 \times $\frac{3}{8}$ screws.
2. Position the chassis assembly in the rack to adjust the support brackets, and note the location for the captive nut fasteners on the rear rack rails.
3. Install four fasteners so the captive nuts are located behind the appropriate holes on the rear rack rails.
4. Loosely attach the chassis assembly to the front and rear rack rails with 10-32 \times $\frac{5}{8}$ screws. Secure the rear support brackets to the chassis.
5. Tighten all screws.

WARNING

The Model 7116-MWS must be separately connected to a safety earth ground to maintain protection against possible shock hazard. Failure to connect the unit to a safety earth ground may result in personal injury or death due to an electric shock.

System earth ground installation

1. Remove all power from the system.
2. Connect the loose end of the six foot green/yellow ground cable to a quality ground located within your facility using the #10 screw provided.

Semi-rigid coax cable installation

WARNING

Contact with exposed conductors carrying RF power may cause burns. Place protective caps on all unused switch inputs. All cables and connectors should be properly mated and shielded.

1. Remove all power from the system.
2. Remove the plastic protective caps from the switch inputs shown in Figure 1-3. Leave the other caps on. Save the removed caps for future use. Connect the cables to the switches as shown in Figure 1-3 and tighten using a $\frac{5}{16}$ inch wrench, to 7-10 in.-lb.

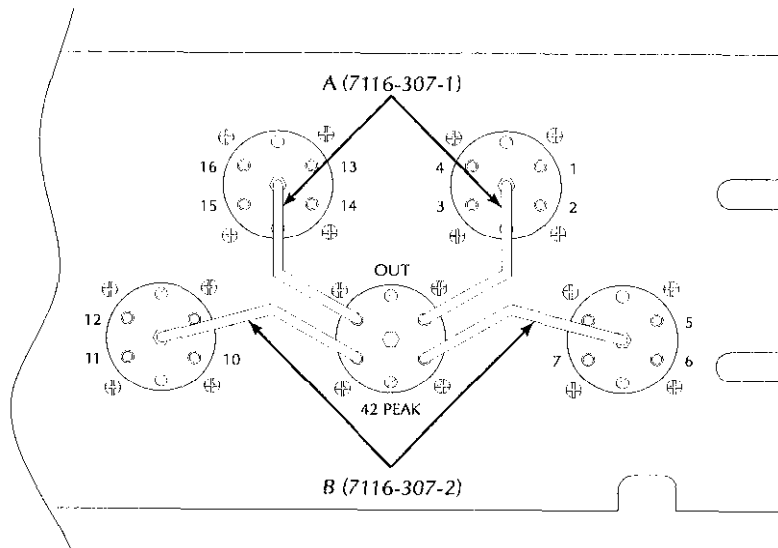

Figure 1-3
Cable installation

2

Operation

Introduction

The Model 7116-MWS system is a 16-input microwave multiplexer. Sixteen inputs are achieved by connecting five single-pole, four-throw switches together forming a tree switching network as shown in Figure 2-1.

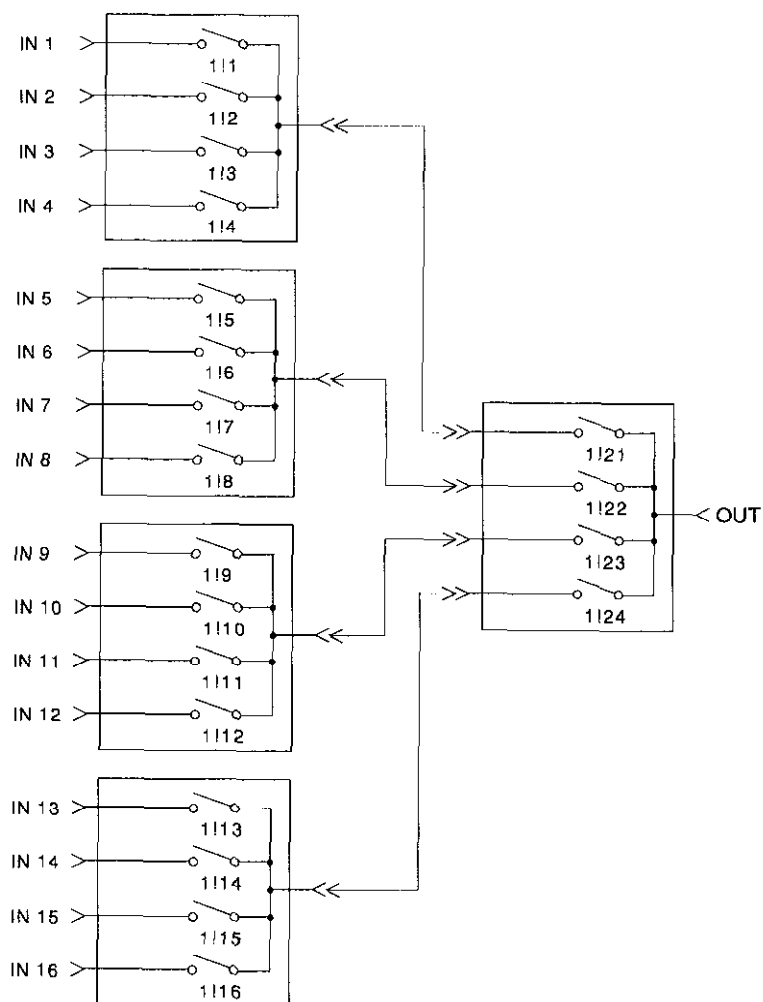

Figure 2-1
Tree switching network

Operating instructions

To select an input channel, the Model 7001 must close two switches at the same time. Table 2-1 lists which Model 7020-MWS digital outputs must be activated to select each respective RF input. The table also shows 7001 channels used to select the inputs.

Table 2-1
Model 7001 channels and memory locations for 1x16 multiplexer

7116-MWS Input	7020-MWS Digital Outputs				7001 Channels	7001 Memory Location	7116-MWS Relays
	Bank A	Bank B	Bank C	Bank D			
Ch. 1	OUT 1		OUT 21		1!1,1!21	M1	K1, K5
Ch. 2	OUT 2		OUT 21		1!2,1!21	M2	
Ch. 3	OUT 3		OUT 21		1!3,1!21	M3	
Ch. 4	OUT 4		OUT 21		1!4,1!21	M4	
Ch. 5	OUT 5		OUT 22		1!5,1!22	M5	K2, K5
Ch. 6	OUT 6		OUT 22		1!6,1!22	M6	
Ch. 7	OUT 7		OUT 22		1!7,1!22	M7	
Ch. 8	OUT 8		OUT 22		1!8,1!22	M8	
Ch. 9		OUT 9	OUT 23		1!9,1!23	M9	K3, K5
Ch. 10		OUT 10	OUT 23		1!10,1!23	M10	
Ch. 11		OUT 11	OUT 23		1!11,1!23	M11	
Ch. 12		OUT 12	OUT 23		1!12,1!23	M12	
Ch. 13		OUT 13	OUT 24		1!13,1!24	M13	K4, K5
Ch. 14		OUT 14	OUT 24		1!14,1!24	M14	
Ch. 15		OUT 15	OUT 24		1!15,1!24	M15	
Ch. 16		OUT 16	OUT 24		1!16,1!24	M16	

Output patterns for each input are stored in the Model 7001 memory at the factory. The user can call up memory locations to select each input. For example, calling up memory location 1 selects input 1. Some programming examples are listed below.

```
PRINT #1,"output 7; :close (@ 1!1,1!21)"           'Channels select input 1
PRINT #1,"output 7; :close (@ M1)"                'Memory location 1 selects input 1
```

NOTE

In either configuration of the Model 7116-MWS, as one 1 x 16 multiplexer or, with the semi-rigid jumper cables removed, as five 1 x 4 multiplexers, ensure that only one channel is closed per relay, and that no more than two relays are energized simultaneously per bank.

For further information on operation and programming, refer to the Models 7001 and 7020 Instruction Manuals.

Power Limits

The Model 7020-MWS card is a modified version of the Model 7020 Digital I/O Interface Card. Among other changes, the output protection network has been removed for greater sink current capacity.

CAUTION

This card is not intended for use in applications other than the Model 7116-MWS system. The 7020-MWS and 7020 cards are not interchangeable. Damage or unintended operation may result if a Model 7020 is substituted for a 7020-MWS.

NOTE

A bank refers to the internal IC that is used to drive eight output channels. The card uses five driver ICs (banks) to accommodate the 40 output channels. The outputs are grouped as follows for each bank:

Bank A = OUT 1 through OUT 8
Bank B = OUT 9 through OUT 16
Bank C = OUT 17 through OUT 24
Bank D = OUT 25 through OUT 32
Bank E = OUT 33 through OUT 40

3

Service

Introduction

The following paragraphs contain troubleshooting and replacement parts information. Schematic diagrams, and component layout drawings for the Model 7116-MWS chassis are also included. Refer to Model 7001 and 7020 manuals for further information about these components.

Troubleshooting

WARNING

The information in this section is intended for qualified service personnel only. Some of the procedures may expose you to hazardous voltages that could result in personal injury or death. Do not attempt to perform these procedures unless you are qualified to do so.

Troubleshooting equipment

The Model 2000 Digital Multimeter is recommended for troubleshooting.

Troubleshooting procedure

Table 3-1 summarizes the procedure for verifying operation of the Model 7116-MWS. Refer to the system schematic and the chassis wiring diagram (drawing number 7116-051) for component locations.

Table 3-1
Troubleshooting procedure

Step	Item/component	Required condition	Comment
1	Chassis		All voltages referenced to chassis
2	K1-K5, pin COM	< 29VDC	Relay coil voltage
3	K1 pin 1, K5 pin 1	< 1.5V	Close channel 1
4	K1 pin 2, K5 pin 1	< 1.5V	Close channel 2
5	K1 pin 3, K5 pin 1	< 1.5V	Close channel 3
6	K1 pin 4, K5 pin 1	< 1.5V	Close channel 4
7	K2 pin 1, K5 pin 2	< 1.5V	Close channel 5
8	K2 pin 2, K5 pin 2	< 1.5V	Close channel 6
9	K2 pin 3, K5 pin 2	< 1.5V	Close channel 7
10	K2 pin 4, K5 pin 2	< 1.5V	Close channel 8
11	K3 pin 1, K5 pin 3	< 1.5V	Close channel 9
12	K3 pin 2, K5 pin 3	< 1.5V	Close channel 10
13	K3 pin 3, K5 pin 3	< 1.5V	Close channel 11
14	K3 pin 4, K5 pin 3	< 1.5V	Close channel 12
15	K4 pin 1, K5 pin 4	< 1.5V	Close channel 13
16	K4 pin 2, K5 pin 4	< 1.5V	Close channel 14
17	K4 pin 3, K5 pin 4	< 1.5V	Close channel 15
18	K4 pin 4, K5 pin 4	< 1.5V	Close channel 16

NOTE: See Table 2-1 for information on closing channels.

Ordering information

To place an order or to obtain information concerning replacement parts, contact your Keithley representative or the factory. When ordering parts, be sure to include the following information:

- Model numbers 7116-MWS, 7020-MWS, and 7001
- Serial number of the chassis, card, or mainframe
- Part description
- Circuit designation (if applicable)
- Keithley part number

Factory service

If the Model 7116-MWS system must be returned to Keithley for repair, perform the following:

1. Call the Repair department at 1-800-552-1115 for a Return Material Authorization (RMA) number.
2. Complete the service form at the back of this manual and include it with the card.
3. Carefully pack the card in the original packing carton.
4. Write ATTENTION REPAIR DEPT and the RMA number on the shipping label.

Engineering drawings

The Model 7116-MWS schematic (7116-MWS-406), chassis assembly (7116-050), and chassis wiring (7116-051) drawings are included on the following pages.

LTR	ECA NO.	REVISION	ENG	DATE
B	24568	Re-draw Detail A, Add CC-37, CC-62, Many Updates		

DETAIL B

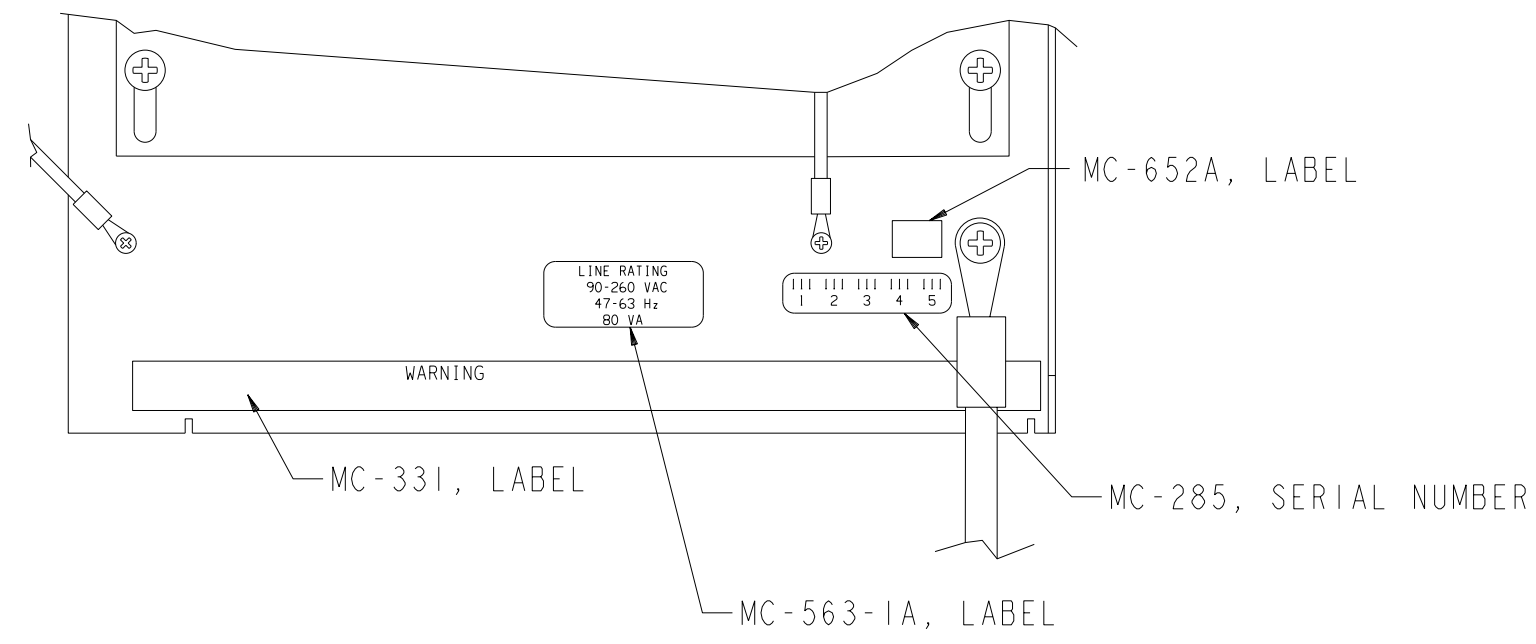

DETAIL A ^B
REAR VIEW FRONT PANEL

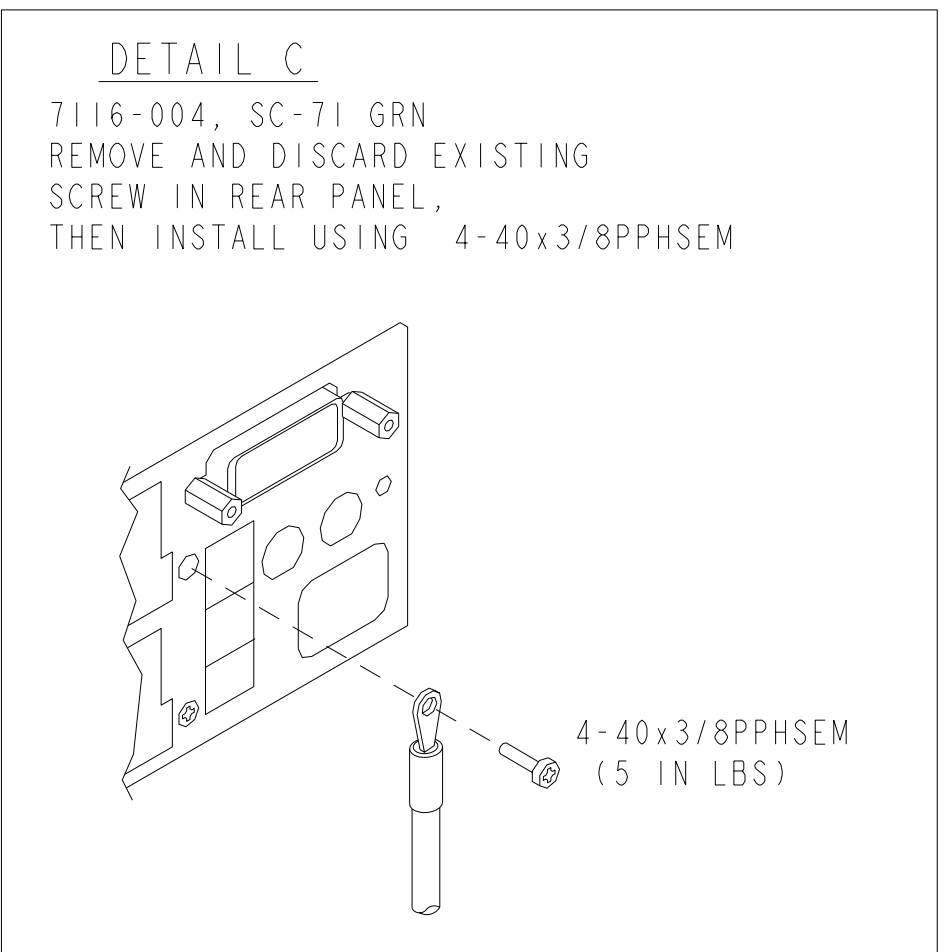
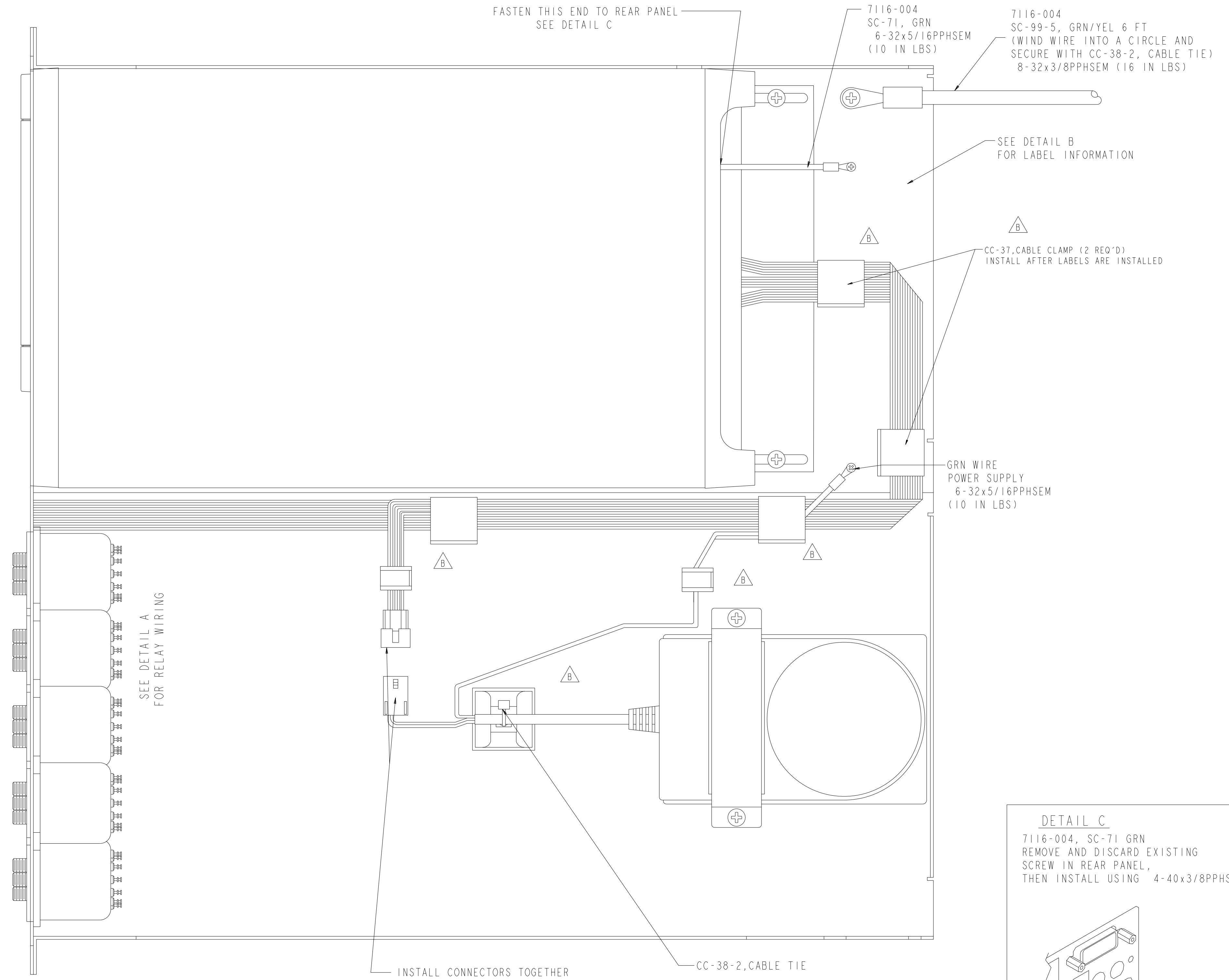
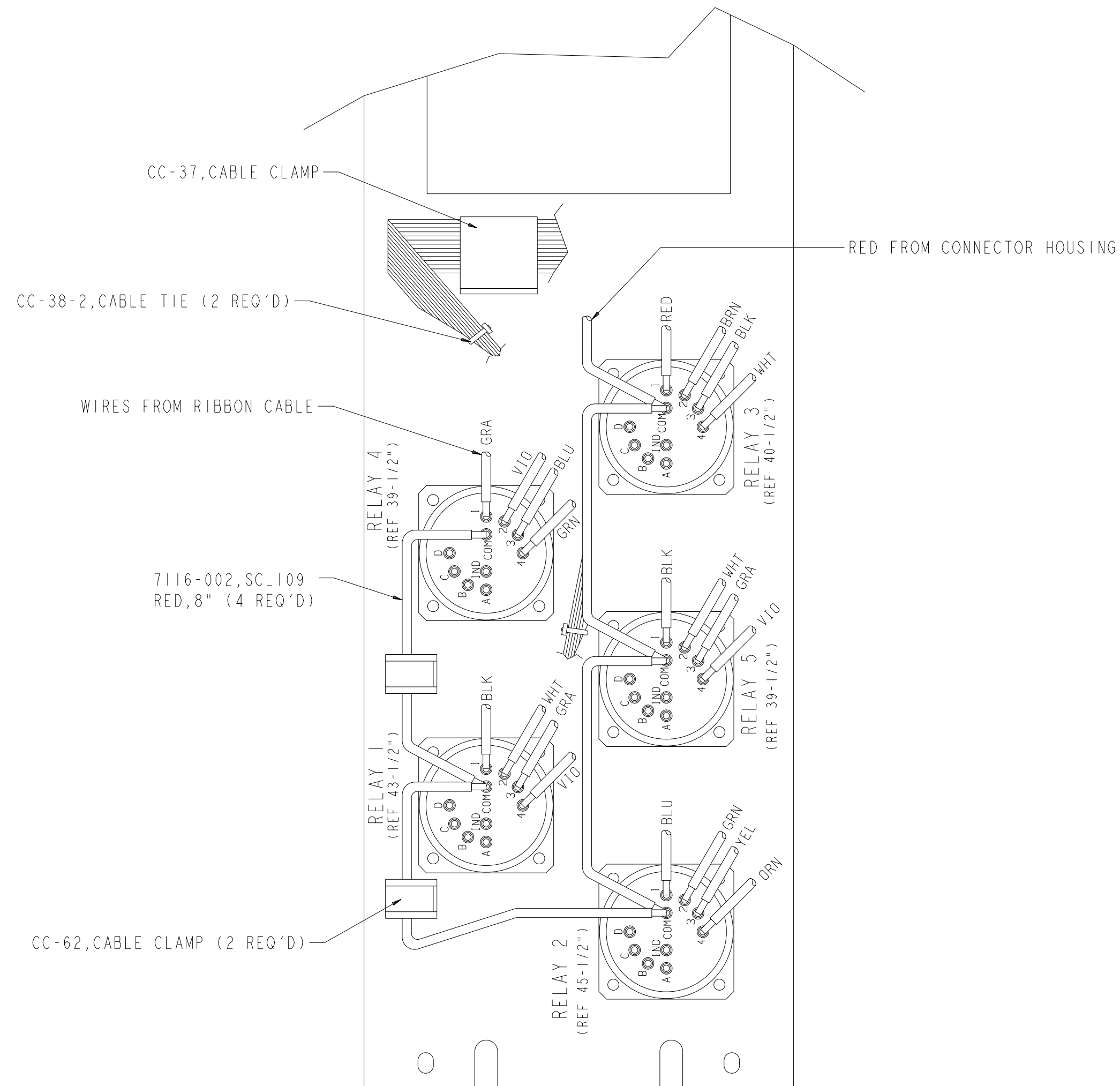

PART NUMBER	QTY	DESCRIPTION
7116-050	1	CHASSIS ASSEMBLY
7116-004	1	CRIMP ASSEMBLY
7116-002	1	WIRE CUTTING CHART
CC-38-2	3	CABLE TIE
MC-285	1	SERIAL NUMBER
MC-331	1	LABEL
MC-563-1A	1	LABEL
MC-652A	1	LABEL
4-40x3/8PPHSEM	1	PHIL PAN HEAD SEMS SCREW
6-32x5/16PPHSEM	2	PHIL PAN HEAD SEMS SCREW
8-32x3/8PPHSEM	1	PHIL PAN HEAD SEMS SCREW
CC-37	3	CABLE CLAMP
CC-62	2	CABLE CLAMP

DO NOT SCALE THIS DRAWING		DIMENSIONAL TOLERANCES UNLESS OTHERWISE SPECIFIED		DATE 8/12/96	SCALE $\times 1$	TITLE
KEITHLEY Keithley Instruments Inc. Cleveland, Ohio 44139		XX $\pm .015$	ANG $\pm 1^\circ$	DRN mot	ENG APPR	CHASSIS WIRING
		XXX $\pm .005$	FRAC $\pm 1/64$	MATERIAL		NO. 7116-051
		SURFACE MAX \checkmark		FINISH		

LTR	ECA NO.	REVISION	ENG	DATE
C	24568	Re-draw Detail A, Add CC-37,CC-62		

DETAIL A

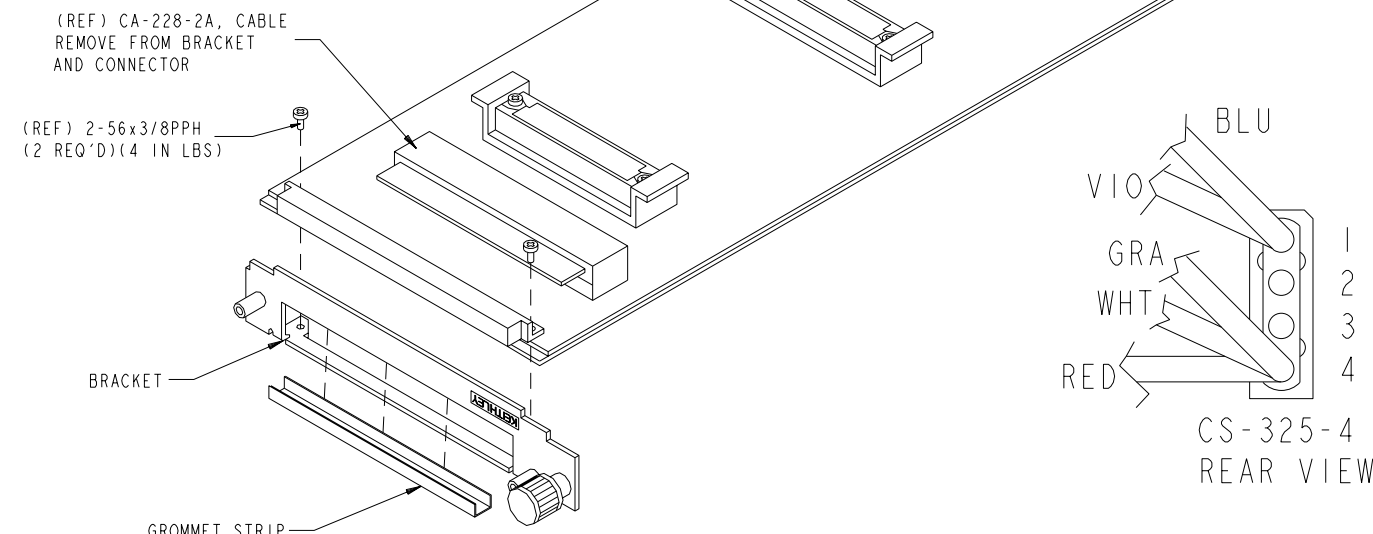

SEND CABLE TO HARNESS TO BE TRIMMED TO LENGTH. INSTALL TRIMMED CABLE TO BRACKET. THEN PLACE CRIMPED WIRES IN HOUSING. INSTALL CABLE AND BRACKET TO BOARD

DETAIL B

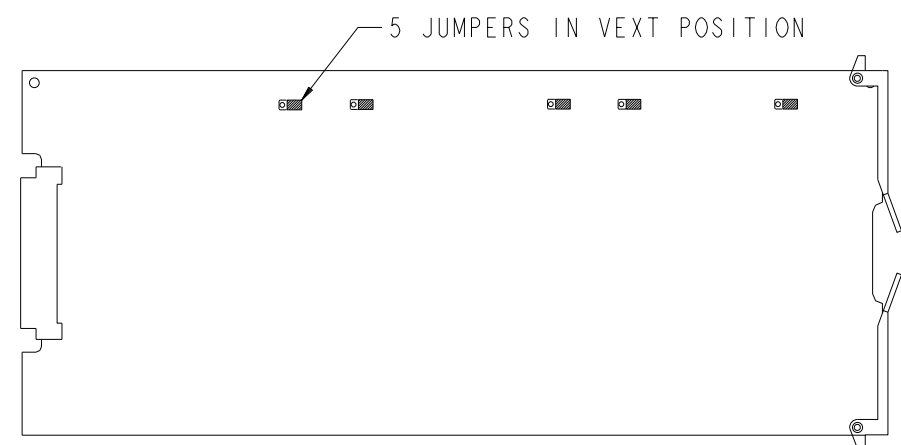

7020-MWS, BOARD ASSEMBLY
SEE DETAIL A
INSTALL IN TOP SLOT OF 7001
RECORD SERIAL NUMBER ON 7116-MWS
HISTORY CARD. VERIFY ON 102 BOARD
THAT THE 5 JUMPERS ARE IN THE
NEXT POSITION. SEE DETAIL B.

8-32x3/8PPHSEM
(2 REQ'D)(16 IN LBS)

4288-4-302B, CLAMP
PUSH TOWARDS FRONT
PANEL AND TIGHTEN

8-32x5/16PPHSEM
(2 REQ'D)(16 IN LBS)

7116-304A, BRACKET

TP-14-2, TAPE - 3" LONG (2 REQ'D)
PLACE ADJACENT TO EACH OTHER ON BRACKET.

7116-004, PS-53 ASSEMBLY
REMOVE COVER ON POWER SUPPLY
WITH 3MM T-HANDLE ALLEN KEY,
THEN SEND TO TECH. WHEN RETURNED
FROM TECH, INSTALL COVER AND PLACE
POWER SUPPLY IN CHASSIS.

MODEL 7001
REMOVE FRONT FEET

7116-301B, CHASSIS

CC-37, CABLE CLAMP
USE T-7794 FOR PLACEMENT

CC-62, CABLE CLAMP
USE T-7794 FOR PLACEMENT

7116-040, FRONT PANEL ASSEMBLY

8LKWA, LOCKWASHER (4 REQ'D)

8-32x1/4PPH
(4 REQ'D)(16 IN LBS)

- TECH:
- 1) USE ANY DC VOLTMEETER WITH .05% ACCURACY 100 VOLT RANGE.
 - 2) CONNECT VOLTMEETER INPUTS TO RED AND BLACK TERMINALS AT THE FRONT OF THE SUPPLY.
 - 3) ADJUST POTENTIOMETER AT THE FRONT RIGHT OF THE SUPPLY TO GET A READING OF 29 VOLTS BETWEEN 28.95 TO 29.05 VOLTS ON THE VOLTMEETER.
 - 4) PLACE A DROP OF LOCTITE 242 THREAD LOCKER ON THE TOP OF THE POTENTIOMETER TO SECURE.
 - 5) LET LOCTITE DRY AND CONFIRM VOLTAGE LEVEL SET IN STEP 3.

CC-47, CABLE CLAMP
USE T-7794 FOR PLACEMENT

PART NUMBER	QTY	DESCRIPTION
7001	1	MODEL 7001
7020-MWS	1	BOARD ASSEMBLY
7116-004	1	CRIMP ASSEMBLY
7116-040	1	FRONT PANEL ASSEMBLY
7116-301B	1	CHASSIS
7116-304A	1	BRACKET
4288-4-302B	1	CLAMP
CC-47	1	CABLE CLAMP
TP-14-2	2	TAPE - 3" LONG
8-32x1/4PPH	4	PHIL PAN HEAD SCREW
8-32x3/8PPHSEM	2	PHIL PAN HEAD SEMS SCREW
8-32x5/16PPHSEM	2	PHIL PAN HEAD SEMS SCREW
8LKWA	4	LOCKWASHER
CC-37	2	CABLE CLAMP
CC-62	2	CABLE CLAMP
CS-325-4	1	CONNECTOR HOUSING

7116-MWS	7116-051	CHASSIS WIRING	1
MODEL	NEXT ASSEMBLY	NEXT PROCESS STEP	QTY
USED ON			

DO NOT SCALE THIS DRAWING		DIMENSIONAL TOLERANCES UNLESS OTHERWISE SPECIFIED		DATE 8/8/96	SCALE \times	TITLE	
XX = ± 0.015		ANG = $\pm 1^\circ$		DRN mat	ENG APPR L.S.	CHASSIS ASSEMBLY	
XXX = ± 0.005		FRAC = $\pm 1/64$		MATERIAL		C	NO. 7116-050
SURFACE MAX \checkmark		FINISH					

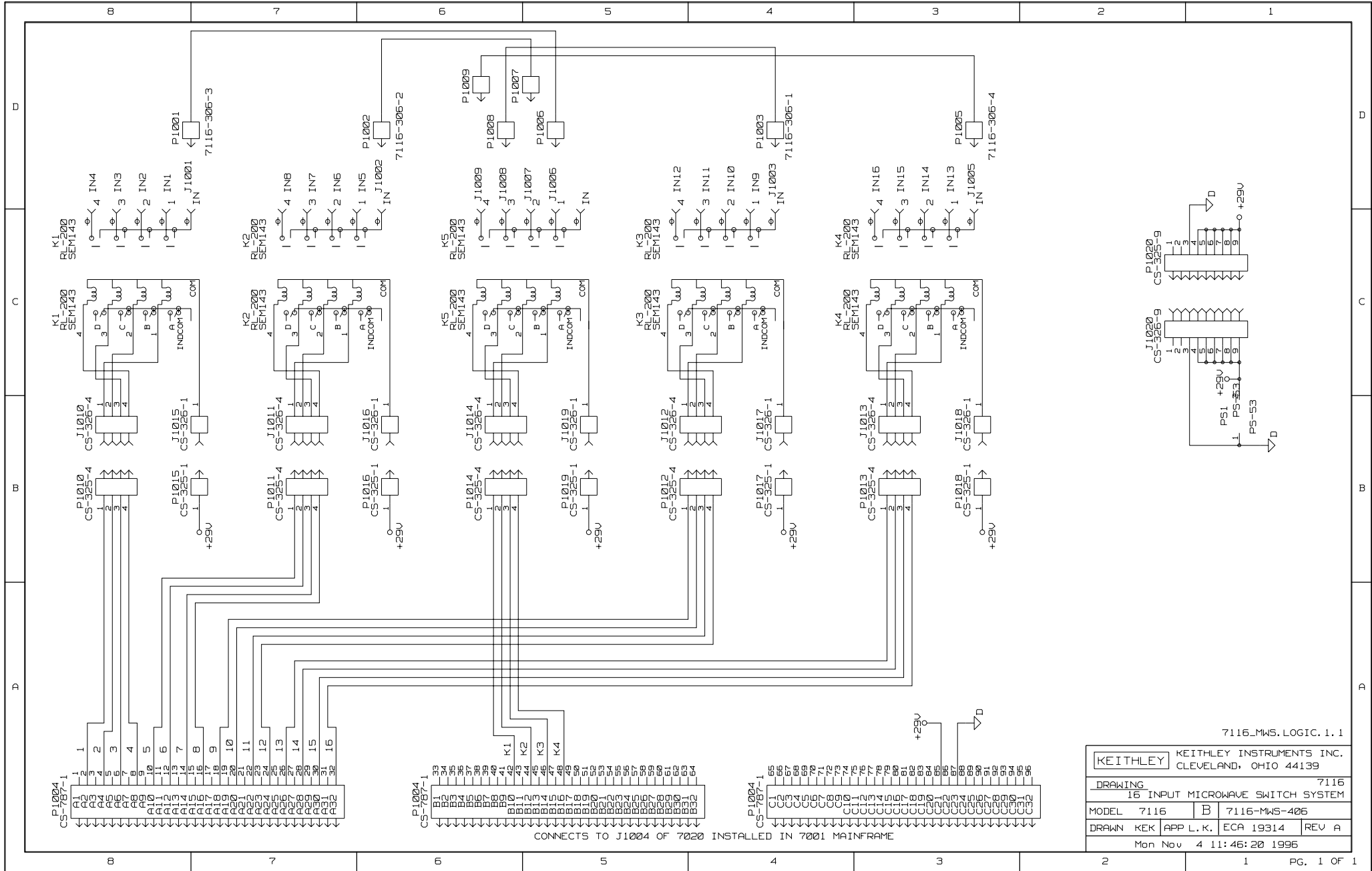

7116.MWS.LOGIC.1.1

KEITHLEY		KEITHLEY INSTRUMENTS INC. CLEVELAND, OHIO 44139	
DRAWING		7116	
16 INPUT MICROWAVE SWITCH SYSTEM			
MODEL	7116	B	7116-MWS-406
DRAWN	KEK	APP	L.K. ECA 19314
		REV	A
Mon Nov 4 11:46:20 1996			

Service Form

Model No. _____ Serial No. _____ Date _____

Name and Telephone No. _____

Company _____

List all control settings, describe problem and check boxes that apply to problem. _____

- | | | |
|--|--|--|
| <input type="checkbox"/> Intermittent | <input type="checkbox"/> Analog output follows display | <input type="checkbox"/> Particular range or function bad; specify |
| <input type="checkbox"/> IEEE failure | <input type="checkbox"/> Obvious problem on power-up | <input type="checkbox"/> Batteries and fuses are OK |
| <input type="checkbox"/> Front panel operational | <input type="checkbox"/> All ranges or functions are bad | <input type="checkbox"/> Checked all cables |

Display or output (check one)

- | | |
|-----------------------------------|--|
| <input type="checkbox"/> Drifts | <input type="checkbox"/> Unable to zero |
| <input type="checkbox"/> Unstable | <input type="checkbox"/> Will not read applied input |
| <input type="checkbox"/> Overload | |

 Calibration only Certificate of calibration required Data required

(attach any additional sheets as necessary)

Show a block diagram of your measurement system including all instruments connected (whether power is turned on or not). Also, describe signal source.

Where is the measurement being performed? (factory, controlled laboratory, out-of-doors, etc.)

What power line voltage is used? _____ Ambient temperature? _____ °F

Relative humidity? _____ Other? _____

Any additional information. (If special modifications have been made by the user, please describe.)

Be sure to include your name and phone number on this service form.

KEITHLEY

Keithley Instruments, Inc.
28775 Aurora Road
Cleveland, Ohio 44139

Printed in the U.S.A.