

7035



- Great fit for low frequency telecom test

Ordering Information

7035 9 Bank 1×4 Multiplexer Switching Card

Accessories Supplied

7011-KIT-R 96-pin Female Connector Kit

7038

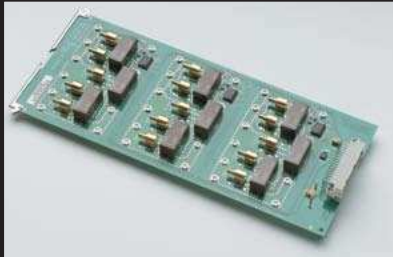

- DC to 2GHz, 75Ω, signal switching
- High channel to channel isolation
- Miniature SMB connectors

Ordering Information

7038 Three 1×4, 2GHz, 75Ω Multiplexer

10MHz 1×4 Multiplexer Card

9 Independent 1×4 2-Pole Multiplexers

The Model 7035 9-Bank Multiplexer Card has nine 1×4 multiplexers. The switch contact configuration for each channel is 2-pole form A. The card's nine banks can be combined for a wide variety of switching configurations using external connections. This flexibility makes the Model 7035 well-suited for production testing of a variety of telecommunications products and systems and low power portable devices.

MULTIPLEX CONFIGURATION: 9 independent 1×4 2-pole multiplex banks.

CONTACT CONFIGURATION: 2-pole Form A (Hi, Lo).

CONNECTOR TYPE: 96-pin male DIN connector (7011-KIT-R mating connector included).

MAXIMUM SIGNAL LEVEL: 60V DC, 30V rms, 42V peak between any two inputs or chassis, 1A switched. 30VA (resistive load).

CONTACT LIFE: Cold Switching: 10⁸ closures. At Maximum Signal Levels: 10⁵ closures.

CHANNEL RESISTANCE (per conductor): <1Ω.

CONTACT POTENTIAL: <2μV per channel contact pair. <5μV typical per single contact.

OFFSET CURRENT: <100pA.

ACTUATION TIME: 3ms.

ISOLATION: **Bank:** >10°Ω, <25 pF.
Channel to Channel: >10°Ω, <50 pF.
Differential: >10°Ω, <100pF.
Common Mode: >10°Ω, <200pF.

CROSSTALK (1MHz, 50Ω Load): **Bank:** <-40dB.
Channel: <-40dB.

INSERTION LOSS (50Ω Source, 50 Load): <0.25dB below 1MHz, <3dB below 10MHz.

RELAY DRIVE CURRENT (per relay): 16mA.

ACCESSORIES AVAILABLE

7011-KIT-R	96-pin Female Connector Kit
7035-MTC-2	96-pin Mass Terminated Cable, Female to Female, 2m
7011-MTR	96-pin Male Connector Kit

SERVICES AVAILABLE

7035-3Y-EW	1-year factory warranty extended to 3 years from date of shipment
------------	---

2GHz RF Switch Card

3 Isolated 1×4 Multiplexers, 75Ω

The Model 7038 75Ω 2.0GHz Multiplexer Card is designed to speed testing and evaluation of a broad-range of telecommunications hardware, including coaxial cable-based equipment, cable television equipment, and high-speed Internet access products. The card simplifies automated switching of high-frequency RF signals, even those with bandwidths of up to 2GHz.

CHARACTERISTIC IMPEDANCE: 75Ω nominal.

MULTIPLEXERS PER CARD: 3 (with isolated ground).

CHANNELS PER MULTIPLEXER: 4.

CONTACT CONFIGURATION: 1-pole, 1 of 4 tree. Channels 1, 5, and 9 normally closed.

RELAY DRIVE CURRENT: 154mA per channel.

CONNECTOR TYPE: 75Ω miniature SMB receptacle.

ACTUATION TIME: 6ms.

MAXIMUM VOLTAGE: Any terminal (center or shield) to any other terminal or chassis: 24V.

MAXIMUM CURRENT: 10mA DC.

MAXIMUM POWER: 10W @ 1.2GHz.

ISOLATION: Multiplexer to Multiplexer: >1GΩ. **Center to Shield:** >1GΩ, 60pF. **Channel to Channel:** >100MΩ.

SIGNAL DELAY: <1ns.

CONTACT POTENTIAL: 15μV.

CONTACT LIFE: 3×10⁵ closures @ 24VDC, 10mA DC; 1×10⁵ closures @ 10W, 1.2GHz signal; 5×10⁸ closures @ cold switching.

CONTACT RESISTANCE: <1Ω.

AC PERFORMANCE:

For $Z_L = Z_S = 75\Omega$	<10 MHz	≤100 MHz	≤500 MHz	≤900 MHz	≤2 GHz
Insertion Loss (dB)	<0.25	<0.5	<1.0	<1.5	<3.0
Crosstalk (dB)					
Channel-to-channel	<-90	<-80	<-65	<-55	<-40
Mux. to Mux.	<-90	<-80	<-70	<-60	<-55
VSWR	<1.2	<1.25	<1.5	<1.5	<2.2

ENVIRONMENT: Operating: 0° to 50°C, up to 35°C at <80% RH. **Storage:** -25°C to 65°C.

EMC: Conforms to European Union Directive 89/336/EEC.

SAFETY: Conforms to European Union Directive 73/23/EEC (meets EN61010-1/IEC 1010).

SERVICES AVAILABLE

7038-3Y-EW	1-year factory warranty extended to 3 years from date of shipment
------------	---

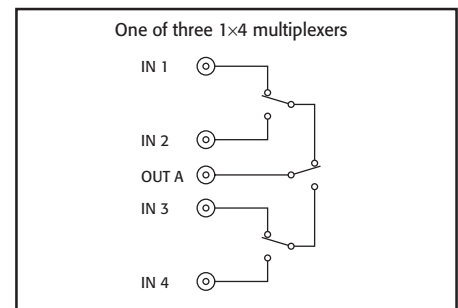

1.888.KEITHLEY (U.S. only)

www.keithley.com

KEITHLEY

A GREATER MEASURE OF CONFIDENCE