

KEITHLEY

Model 7019-C Six-Wire Ohms Matrix Card

Instruction Manual

A GREATER MEASURE OF CONFIDENCE

www.valuetronics.com

WARRANTY

Keithley Instruments, Inc. warrants this product to be free from defects in material and workmanship for a period of 1 year from date of shipment.

Keithley Instruments, Inc. warrants the following items for 90 days from the date of shipment: probes, cables, rechargeable batteries, diskettes, and documentation.

During the warranty period, we will, at our option, either repair or replace any product that proves to be defective.

To exercise this warranty, write or call your local Keithley representative, or contact Keithley headquarters in Cleveland, Ohio. You will be given prompt assistance and return instructions. Send the product, transportation prepaid, to the indicated service facility. Repairs will be made and the product returned, transportation prepaid. Repaired or replaced products are warranted for the balance of the original warranty period, or at least 90 days.

LIMITATION OF WARRANTY

This warranty does not apply to defects resulting from product modification without Keithley's express written consent, or misuse of any product or part. This warranty also does not apply to fuses, software, non-rechargeable batteries, damage from battery leakage, or problems arising from normal wear or failure to follow instructions.

THIS WARRANTY IS IN LIEU OF ALL OTHER WARRANTIES, EXPRESSED OR IMPLIED, INCLUDING ANY IMPLIED WARRANTY OF MERCHANTABILITY OR FITNESS FOR A PARTICULAR USE. THE REMEDIES PROVIDED HEREIN ARE BUYER'S SOLE AND EXCLUSIVE REMEDIES.

NEITHER KEITHLEY INSTRUMENTS, INC. NOR ANY OF ITS EMPLOYEES SHALL BE LIABLE FOR ANY DIRECT, INDIRECT, SPECIAL, INCIDENTAL OR CONSEQUENTIAL DAMAGES ARISING OUT OF THE USE OF ITS INSTRUMENTS AND SOFTWARE EVEN IF KEITHLEY INSTRUMENTS, INC., HAS BEEN ADVISED IN ADVANCE OF THE POSSIBILITY OF SUCH DAMAGES. SUCH EXCLUDED DAMAGES SHALL INCLUDE, BUT ARE NOT LIMITED TO: COSTS OF REMOVAL AND INSTALLATION, LOSSES SUSTAINED AS THE RESULT OF INJURY TO ANY PERSON, OR DAMAGE TO PROPERTY.



Keithley Instruments, Inc. • 28775 Aurora Road • Cleveland, OH 44139 • 440-248-0400 • Fax: 440-248-6168 • <http://www.keithley.com>

BELGIUM:	Keithley Instruments B.V.	Bergensesteenweg 709 • B-1600 Sint-Pieters-Leeuw • 02/363 00 40 • Fax: 02/363 00 64
CHINA:	Keithley Instruments China	Yuan Chen Xin Building, Room 705 • 12 Yumin Road, Dewai, Madian • Beijing 100029 • 8610-62022886 • Fax: 8610-62022892
FRANCE:	Keithley Instruments Sarl	3, allée des Garays • 91127 Palaiseau Cedex • 01-64 53 20 20 • Fax: 01-60 11 77 26
GERMANY:	Keithley Instruments GmbH	Landsberger Strasse 65 • 82110 Germering • 089/84 93 07-40 • Fax: 089/84 93 07-34
GREAT BRITAIN:	Keithley Instruments Ltd	The Minster • 58 Portman Road • Reading, Berkshire RG30 1EA • 0118-9 57 56 66 • Fax: 0118-9 59 64 69
INDIA:	Keithley Instruments GmbH	Flat 2B, WILOCRISSA • 14, Rest House Crescent • Bangalore 560 001 • 91-80-509-1320/21 • Fax: 91-80-509-1322
ITALY:	Keithley Instruments s.r.l.	Viale S. Gimignano, 38 • 20146 Milano • 02-48 39 16 01 • Fax: 02-48 30 22 74
NETHERLANDS:	Keithley Instruments B.V.	Postbus 559 • 4200 AN Gorinchem • 0183-635333 • Fax: 0183-630821
SWITZERLAND:	Keithley Instruments SA	Kriesbachstrasse 4 • 8600 Dübendorf • 01-821 94 44 • Fax: 01-820 30 81
TAIWAN:	Keithley Instruments Taiwan	1 Fl. 85 Po Ai Street • Hsinchu, Taiwan, R.O.C. • 886-3572-9077 • Fax: 886-3572-903

Model 7019-C Six-Wire Ohms Matrix Card Instruction Manual

©1996, Keithley Instruments, Inc.
All rights reserved.
Cleveland, Ohio, U.S.A.
Second Printing, April 2001
Document Number: 7019-901-01 Rev. B

Manual Print History

The print history shown below lists the printing dates of all Revisions and Addenda created for this manual. The Revision Level letter increases alphabetically as the manual undergoes subsequent updates. Addenda, which are released between Revisions, contain important change information that the user should incorporate immediately into the manual. Addenda are numbered sequentially. When a new Revision is created, all Addenda associated with the previous Revision of the manual are incorporated into the new Revision of the manual. Each new Revision includes a revised copy of this print history page.

Revision A (Document Number 7019-901-01) July 1996
Addendum A (Document Number 7019-901-02)..... September 1996
Revision B (Document Number 7019-901-01) April 2001

Safety Precautions

The following safety precautions should be observed before using this product and any associated instrumentation. Although some instruments and accessories would normally be used with non-hazardous voltages, there are situations where hazardous conditions may be present.

This product is intended for use by qualified personnel who recognize shock hazards and are familiar with the safety precautions required to avoid possible injury. Read the operating information carefully before using the product.

The types of product users are:

Responsible body is the individual or group responsible for the use and maintenance of equipment, for ensuring that the equipment is operated within its specifications and operating limits, and for ensuring that operators are adequately trained.

Operators use the product for its intended function. They must be trained in electrical safety procedures and proper use of the instrument. They must be protected from electric shock and contact with hazardous live circuits.

Maintenance personnel perform routine procedures on the product to keep it operating, for example, setting the line voltage or replacing consumable materials. Maintenance procedures are described in the manual. The procedures explicitly state if the operator may perform them. Otherwise, they should be performed only by service personnel.

Service personnel are trained to work on live circuits, and perform safe installations and repairs of products. Only properly trained service personnel may perform installation and service procedures.

Keithley products are designed for use with electrical signals that are rated Installation Category I and Installation Category II, as described in the International Electrotechnical Commission (IEC) Standard IEC 60664. Most measurement, control, and data I/O signals are Installation Category I and must not be directly connected to mains voltage or to voltage sources with high transient over-voltages. Installation Category II connections require protection for high transient over-voltages often associated with local AC mains connections. The user should assume all measurement, control, and data I/O connections are for connection to Category I sources unless otherwise marked or described in the Manual.

Exercise extreme caution when a shock hazard is present. Lethal voltage may be present on cable connector jacks or test fixtures. The American National Standards Institute (ANSI) states that a shock hazard exists when voltage levels greater than 30V RMS, 42.4V peak, or 60VDC are present. **A good safety practice is to expect that hazardous voltage is present in any unknown circuit before measuring.**

Users of this product must be protected from electric shock at all times. The responsible body must ensure that users are prevented access and/or insulated from every connection point. In some cases, connections must be exposed to potential human contact. Product users in these circumstances must be trained to protect themselves from the risk of electric shock. If the circuit is capable of operating at or above 1000 volts, **no conductive part of the circuit may be exposed.**

Do not connect switching cards directly to unlimited power circuits. They are intended to be used with impedance limited sources. NEVER connect switching cards directly to AC mains. When connecting sources to switching cards, install protective devices to limit fault current and voltage to the card.

Before operating an instrument, make sure the line cord is connected to a properly grounded power receptacle. Inspect the connecting cables, test leads, and jumpers for possible wear, cracks, or breaks before each use.

When installing equipment where access to the main power cord is restricted, such as rack mounting, a separate main input power disconnect device must be provided, in close proximity to the equipment and within easy reach of the operator.

For maximum safety, do not touch the product, test cables, or any other instruments while power is applied to the circuit under test. ALWAYS remove power from the entire test system and discharge any capacitors before: connecting or disconnecting cables or jumpers, installing or removing switching cards, or making internal changes, such as installing or removing jumpers.

Do not touch any object that could provide a current path to the common side of the circuit under test or power line (earth) ground. Always make measurements with dry hands while standing on a dry, insulated surface capable of withstanding the voltage being measured.

The instrument and accessories must be used in accordance with its specifications and operating instructions or the safety of the equipment may be impaired.

Do not exceed the maximum signal levels of the instruments and accessories, as defined in the specifications and operating information, and as shown on the instrument or test fixture panels, or switching card.

When fuses are used in a product, replace with same type and rating for continued protection against fire hazard.

Chassis connections must only be used as shield connections for measuring circuits, NOT as safety earth ground connections.

If you are using a test fixture, keep the lid closed while power is applied to the device under test. Safe operation requires the use of a lid interlock.

If a  screw is present, connect it to safety earth ground using the wire recommended in the user documentation.

The  symbol on an instrument indicates that the user should refer to the operating instructions located in the manual.

The  symbol on an instrument shows that it can source or measure 1000 volts or more, including the combined effect of normal and common mode voltages. Use standard safety precautions to avoid personal contact with these voltages.

The **WARNING** heading in a manual explains dangers that might result in personal injury or death. Always read the associated information very carefully before performing the indicated procedure.

The **CAUTION** heading in a manual explains hazards that could damage the instrument. Such damage may invalidate the warranty.

Instrumentation and accessories shall not be connected to humans.

Before performing any maintenance, disconnect the line cord and all test cables.

To maintain protection from electric shock and fire, replacement components in mains circuits, including the power transformer, test leads, and input jacks, must be purchased from Keithley Instruments. Standard fuses, with applicable national safety approvals, may be used if the rating and type are the same. Other components that are not safety related may be purchased from other suppliers as long as they are equivalent to the original component. (Note that selected parts should be purchased only through Keithley Instruments to maintain accuracy and functionality of the product.) If you are unsure about the applicability of a replacement component, call a Keithley Instruments office for information.

To clean an instrument, use a damp cloth or mild, water based cleaner. Clean the exterior of the instrument only. Do not apply cleaner directly to the instrument or allow liquids to enter or spill on the instrument. Products that consist of a circuit board with no case or chassis (e.g., data acquisition board for installation into a computer) should never require cleaning if handled according to instructions. If the board becomes contaminated and operation is affected, the board should be returned to the factory for proper cleaning/servicing.

7019-C Six-Wire Ohms Matrix Card Specifications

MATRIX CONFIGURATION: Dual 3 rows by 6 columns, plus two utility pathways with two 2-channel multiplexer rows. Jumpers can be removed to isolate any row from the backplane.

CONTACT CONFIGURATION: 1 pole Form A.

CONNECTOR TYPE: 96-pin male DIN connector.

MAXIMUM VOLTAGE: Any input to any other input or chassis: 200V peak.

MAXIMUM CURRENT: 1A carry/0.5A switched.

MAXIMUM POWER: 10VA.

CONTACT LIFE: 1V, 10mA: 10^8 closures.
20V, 0.5A: 5×10^4 closures.

CHANNEL RESISTANCE: $<0.5\Omega$ initial, 1Ω at end of contact life.

CONTACT POTENTIAL: $<25\mu\text{V}$ per single contact or pair.

ACTUATION TIME: 500 μs .

ISOLATION:

Path: $>10^9\Omega$, $<50\text{pF}$.

Differential: $>10^9\Omega$, $<400\text{pF}$.

Common Mode: $>10^9\Omega$, $<400\text{pF}$.

OFFSET CURRENT: $<100\text{pA}$.

INSERTION LOSS (50 Ω Source, 50 Ω Load): $<0.35\text{dB}$ below 1MHz, $<3\text{dB}$ below 2MHz.

CROSSTALK (1MHz, 50 Ω Load): -40dB .

RELAY DRIVE CURRENT: 15mA per channel.

ENVIRONMENT: Operating: 0° to 50°C , up to 35°C at $<80\%$ R.H. **Storage:** -25° to 65°C .

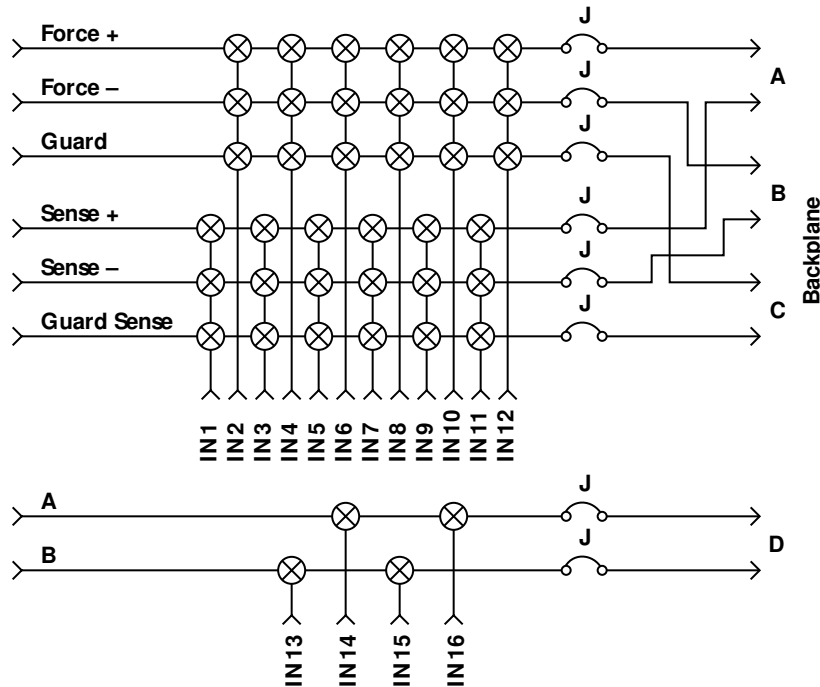

Table of Contents

1 General Information

1.1	Introduction	1-1
1.2	Features	1-1
1.3	Warranty information.....	1-1
1.4	Manual addenda	1-1
1.5	Safety symbols and terms	1-2
1.6	Specifications	1-2
1.7	Unpacking and inspection	1-2
1.7.1	Inspection for damage	1-2
1.7.2	Handling precautions	1-2
1.7.3	Shipping contents	1-2
1.7.4	Instruction manual.....	1-2
1.7.5	Repacking for shipment	1-2
1.8	Optional accessories.....	1-2

2 Matrix Switching Basics

2.1	Introduction	2-1
2.2	Basic matrix configuration.....	2-1
2.2.1	Backplane jumpers	2-1
2.2.2	Mainframe analog backplane	2-1
2.2.3	Row connections to backplane.....	2-2
2.3	Typical matrix switching schemes	2-3
2.3.1	Six-wire ohms matrix switching	2-3
2.3.2	Utility pathway switching	2-3
2.4	Matrix expansion.....	2-3
2.4.1	Isolated switching systems	2-3
2.4.2	Matrix expansion (dual 3×12 matrix)	2-3

3 Card Connections and Installation

3.1	Introduction	3-1
3.2	Handling precautions	3-1
3.3	Connections	3-1
3.3.1	Backplane row jumpers	3-1
3.3.2	Connector terminal identification	3-2
3.3.3	Typical connection techniques	3-4
3.3.4	Connector insulation and cleaning.....	3-6
3.4	Typical connection schemes	3-6
3.4.1	Single-card system.....	3-6
3.4.2	Multi-card system	3-7
3.5	Model 7019-C installation and removal	3-8
3.5.1	Matrix card installation.....	3-8
3.5.2	Matrix card removal	3-9

4 Operation

4.1	Introduction	4-1
4.2	Safety and signal considerations.....	4-1
4.2.1	Safety considerations	4-1
4.2.2	Maximum signal levels.....	4-1
4.2.3	Maximizing relay life	4-1
4.3	Mainframe control of matrix card.....	4-1
4.3.1	Channel assignments	4-2
4.3.2	Front panel control.....	4-3
4.3.3	IEEE-488 bus operation.....	4-3
4.3.4	Automatic crosspoint sequencing	4-3
4.4	Measurement considerations	4-3
4.4.1	Path isolation	4-4
4.4.2	Magnetic fields	4-4
4.4.3	Radio frequency interference.....	4-4
4.4.4	Ground loops	4-4
4.4.5	Keeping connectors clean.....	4-5
4.5	Six-wire ohms resistance testing applications	4-5
4.5.1	Types of resistor networks.....	4-5
4.5.2	Typical resistor network tests	4-6
4.5.3	Six-wire ohms measurement technique	4-6
4.5.4	Six-wire ohms test switching connections.....	4-7
4.5.5	Basic six-wire ohms test procedure	4-7
4.5.6	Split Kelvin measurement technique	4-8
4.5.7	Split Kelvin test connections	4-9
4.5.8	Basic test procedure	4-9

5 Servicing

5.1	Introduction	5-1
5.2	Handling and cleaning precautions	5-1
5.3	Performance verification	5-1
5.3.1	Environmental conditions	5-2
5.3.2	Recommended verification equipment	5-2
5.3.3	Matrix card connections	5-2
5.3.4	Channel resistance tests	5-4
5.3.5	Offset current tests	5-5
5.3.6	Path isolation tests	5-6
5.3.7	Common-mode isolation tests	5-7
5.4	Special handling of static-sensitive devices	5-8
5.5	Principles of operation	5-8
5.5.1	Block diagram	5-8
5.5.2	Card identification ROM	5-8
5.5.3	Relay control	5-8
5.5.4	Power-on safeguard	5-8
5.6	Troubleshooting	5-9
5.6.1	Troubleshooting equipment	5-9
5.6.2	Troubleshooting access	5-9
5.6.3	Troubleshooting procedure	5-9

6 Replaceable Parts

6.1	Introduction	6-1
6.2	Parts lists	6-1
6.3	Ordering information	6-1
6.4	Factory service	6-1
6.5	Component layouts and schematic diagrams	6-1

List of Illustrations

2 Matrix Switching Basics

Figure 2-1	Simplified Model 7019-C schematic	2-2
Figure 2-2	Mainframe analog backplane	2-2
Figure 2-3	Row connections to backplane	2-2
Figure 2-4	Six-wire ohms matrix switching	2-3
Figure 2-5	Utility pathway switching	2-3
Figure 2-6	Isolated switching system	2-4
Figure 2-7	Dual 3×12 matrix	2-4

3 Card Connections and Installation

Figure 3-1	Backplane row jumpers	3-2
Figure 3-2	Model 7019-C connector terminal identification	3-3
Figure 3-3	Typical round cable connection techniques	3-5
Figure 3-4	Model 7011-MTR connector pinout	3-6
Figure 3-5	Model 7011-KIT-R assembly, shown with cables	3-6
Figure 3-6	Single-card system example	3-7
Figure 3-7	Two-card system connection example	3-8
Figure 3-8	Model 7019-C installation in Model 7001	3-9
Figure 3-9	Model 7019-C installation into Model 7002	3-9

4 Operation

Figure 4-1	Channel status display	4-2
Figure 4-2	Model 7019-C card channel/crosspoint assignments	4-2
Figure 4-3	Path isolation resistance	4-4
Figure 4-4	Ground loops	4-5
Figure 4-5	Ground loop elimination connections	4-5
Figure 4-6	Types of resistor networks	4-6
Figure 4-7	Six-wire ohms guarded measurement technique	4-7
Figure 4-8	Six-wire ohms test connections	4-8
Figure 4-9	Split Kelvin measurement technique	4-8
Figure 4-10	Split Kelvin test connections	4-9

5 Servicing

Figure 5-1	96-pin connector terminal identification	5-3
Figure 5-2	Connections for channel resistance tests	5-4
Figure 5-3	Connections for offset current tests	5-5
Figure 5-4	Connections for path isolation tests	5-6
Figure 5-5	Connections for common-mode isolation tests.....	5-7
Figure 5-6	Block diagram.....	5-9

List of Tables

2 Matrix Switching Basics

Table 2-1	SourceMeter matrix connections.....	2-3
-----------	-------------------------------------	-----

3 Card Connections and Installation

Table 3-1	Backplane jumper identification	3-2
Table 3-2	Connector accessories	3-4

4 Operation

Table 4-1	Crosspoint channel assignments	4-3
Table 4-2	SourceMeter and matrix card connections.....	4-7

5 Servicing

Table 5-1	Recommended verification equipment	5-2
Table 5-2	Channel resistance test summary	5-5
Table 5-3	Offset current test summary	5-6
Table 5-4	Path isolation test summary	5-7
Table 5-5	Common-mode isolation test summary	5-8
Table 5-6	Recommended troubleshooting equipment.....	5-9
Table 5-7	Troubleshooting procedure	5-10

6 Replaceable Parts

Table 6-1	Relay board parts list.....	6-2
Table 6-2	Connector board parts list	6-2

General Information

1.1 Introduction

This section contains general information about the Model 7019-C Six-Wire Ohms Matrix Card. The Model 7019-C is designed specifically to provide both six-wire ohms connections and “split kelvin” configurations, as well as general-purpose multiplexing, all in one system. The Model 7019-C is optimized for use with the series 2400 SourceMeters.

The Model 7019-C assembly consists of a multi-pin (mass termination) connector card and the relay card. External test circuit connections to the matrix are made via the 96-pin male DIN connector on the connector card. Keithley offers a variety of optional accessories that can be used to make connections to the connector card (refer to paragraph 1.8).

1.2 Features

The Model 7019-C is a single-pole, dual, 3×6 (three rows by six columns) matrix card. Some of the key features include:

- Reed relays for long contact life and fast actuation, making the Model 7019-C suitable for production testing.
- Design optimized for use with the six-wire ohms feature of the series 2400 SourceMeters, while also providing for “split kelvin” connections and general-purpose multiplexing to resistive networks.

- High isolation resistance ($>1G\Omega$) for minimal loading effects when making resistance measurements.
- Low contact potential and offset current for minimal effects on low-level signals.
- Backplane row jumpers. Cutting jumpers disconnects rows from the Model 7001 or Model 7002 analog backplane.

1.3 Warranty information

Warranty information is located on the inside front cover of this manual. Should your Model 7019-C require warranty service, contact the Keithley representative or authorized repair facility in your area for further information. When returning the matrix card for repair, be sure to fill out and include the service form at the back of this manual in order to provide the repair facility with the necessary information.

1.4 Manual addenda

Any improvements or changes concerning the matrix card or manual will be explained in an addendum included with the card. Addenda are provided in a page replacement format. Simply replace the obsolete pages with the new pages.

1.5 Safety symbols and terms

The following symbols and terms may be found on an instrument or used in this manual.

The  symbol on an instrument indicates that the user should refer to the operating instructions located in the instruction manual.

The  symbol on an instrument indicates that high voltage may be present on the terminal(s). Use standard safety precautions to avoid personal contact with these voltages.

The **WARNING** heading used in this manual explains dangers that might result in personal injury or death. Always read the associated information very carefully before performing the indicated procedure.

The **CAUTION** heading used in this manual explains hazards that could damage the matrix card. Such damage may invalidate the warranty.

1.6 Specifications

Model 7019-C specifications are found at the front of this manual. These specifications are exclusive of the switching mainframe specifications.

1.7 Unpacking and inspection

1.7.1 Inspection for damage

The Model 7019-C is packaged in a re-sealable, anti-static bag to protect it from damage due to static discharge and from contamination that could degrade its performance. Before removing the card from the bag, observe the following precautions on handling.

1.7.2 Handling precautions

- Always grasp the card by the side edges and shields. Do not touch the board surfaces or components.
- When not installed in a Model 7001 or 7002 mainframe, keep the card in the anti-static bag, and store it in the original packing carton.
- After removing the card from its anti-static bag, inspect it for any obvious signs of physical damage. Report any damage to the shipping agent immediately.

1.7.3 Shipping contents

The following items are included with every Model 7019-C order:

- Model 7019-C Six-Wire Ohms Matrix Card
- Model 7019-C Instruction Manual
- Additional accessories as ordered

1.7.4 Instruction manual

If an additional instruction manual is required, order the manual package, Keithley part number 7019-901-00. The manual package includes an instruction manual and any pertinent addenda.

1.7.5 Repacking for shipment

Should it become necessary to return the Model 7019-C for repair, carefully pack the unit in its original packing carton or the equivalent, and include the following information:

- Call the Repair Department at 1-800-552-1115 for a Return Material Authorization (RMA) number.
- Advise as to the warranty status of the matrix card.
- Write ATTENTION REPAIR DEPARTMENT and the RMA number on the shipping label.
- Fill out and include the service form located at the back of this manual.

1.8 Optional accessories

The following accessories are available for use with the Model 7019-C.

Model 7011-KIT-R—This connection kit includes a 96-pin female DIN connector that will mate directly to the connector on the Model 7019-C or to a standard 96-pin male DIN bulkhead connector (see Model 7011-MTR). This connector uses solder cups for connections to external circuitry. It includes an adapter for a round cable and the housing.

Model 7011-MTC-2—This two-meter round cable assembly is terminated with a 96-pin female DIN connector on each end. It will mate directly to the connector on the Model 7019-C and to a standard 96-pin male DIN bulkhead connector (see Model 7011-MTR).

Model 7011-MTR—This 96-pin male DIN bulkhead connector uses solder cups for connections to external circuitry. It will mate to the Model 7011-KIT-R connector and Model 7011-MTC-2 cable assembly.

2

Matrix Switching Basics

2.1 Introduction

This section covers the basics for matrix switching. For details on card connections and installation, refer to Section 3.

2.2 Basic matrix configuration

A simplified schematic of the Model 7019-C matrix card is shown in Figure 2-1. The card is configured as two independent 3×6 matrices. Each of the 36 crosspoints is made up of a single-pole switch. By closing the appropriate crosspoint switch, any of the three rows in one matrix can be connected to any of the six columns in the same 3×6 matrix.

One 3×6 matrix switches the FORCE+, FORCE−, and GUARD signals of the SourceMeter, while the second matrix switches the SENSE+, SENSE−, and GUARD SENSE terminals. The odd-numbered column inputs (IN1 through IN11) can be connected to the SENSE+, SENSE−, and GUARD SENSE rows through the appropriate crosspoints, while the even-numbered column inputs (IN2 through IN12) can be switched to the FORCE+, FORCE−, and GUARD rows.

In addition to the two 3×6 matrices, there is an extra set of utility rows (A and B) that can be used for other switching purposes.

2.2.1 Backplane jumpers

As shown in Figure 2-1, there are four pairs of backplane jumpers located on the relay card. Six of the jumpers are associated with the six-wire ohms pathways (Banks A, B, and C). The remaining two jumpers are connected to the utility pathways A and B, which are connected to Bank D.

With the jumpers installed, the matrix card is connected to the analog backplane of the Model 7001 or 7002, allowing matrix expansion with other Model 7019-C cards installed in the mainframe. With the jumpers removed (cut), the matrix card is electrically isolated from any other switching card installed in the mainframe.

2.2.2 Mainframe analog backplane

The analog backplane of the mainframe is shown in Figure 2-2. The analog backplane allows the rows of a Model 7019-C matrix card installed in one slot to be connected to the rows of another Model 7019-C card installed in another slot of the mainframe.

Each of the four Model 7001/7002 backplane banks has a high (H), low (L), and guard (G) pathway. The guard pathways are not used by the Model 7019-C.

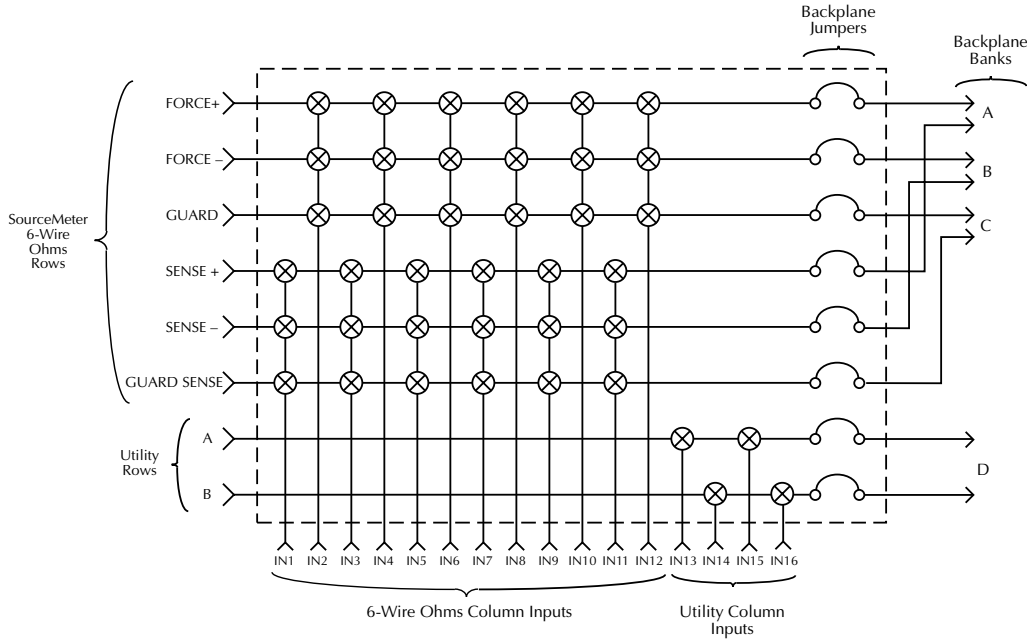

Figure 2-1
Simplified Model 7019-C schematic

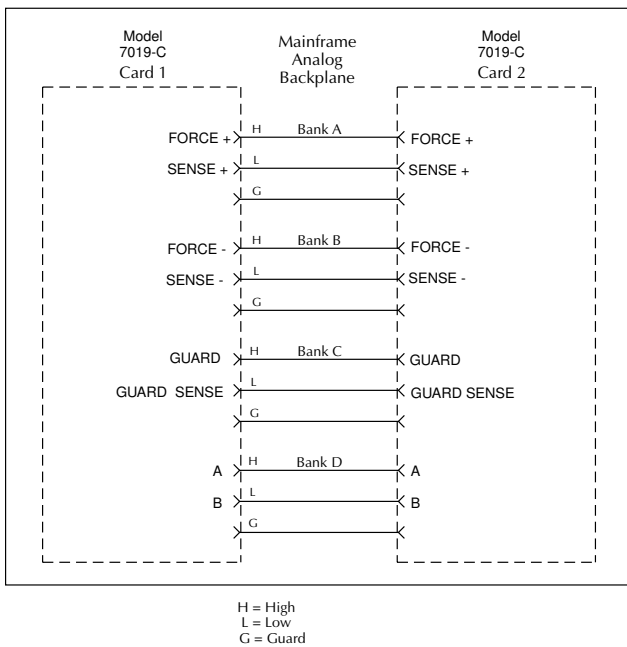

Figure 2-2
Mainframe analog backplane

2.2.3 Row connections to backplane

Figure 2-3 shows how rows of the Model 7019-C are connected to the backplane through the backplane jumpers. As noted, the G (guard) pathways are not used by the Model 7019-C.

The Model 7019-C is shipped from the factory with the backplane row jumpers installed. Removing (cutting) the backplane jumpers isolates the card from the backplane, and subsequently, any card installed in any other slot. For information on removing the jumpers, refer to paragraph 3.3.1.

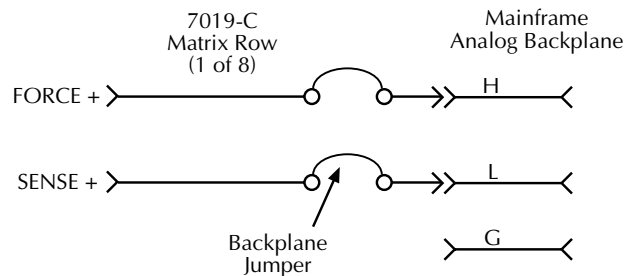

Figure 2-3
Row connections to backplane

2.3 Typical matrix switching schemes

The following paragraphs give an overview of the two basic switching schemes that are possible with the Model 7019-C: six-wire ohms switching and utility pathway switching.

These switching schemes should include shielding configurations to help minimize noise pickup in sensitive measurement applications. These shields are normally connected to chassis ground. For some test configurations, shielding may be more effectively connected to circuit common. Chassis ground is accessible at the rear panel of the series 2400 SourceMeters, as well as at the rear panel of the Model 7001/7002. Note, however, that shields should normally be connected only at one end to avoid noise problems caused by ground loops.

2.3.1 Six-wire ohms matrix switching

Figure 2-4 shows the basic method for connecting the series 2400 SourceMeters to the two 3x6 matrices. Note that the SourceMeter is connected to the rows, and the DUTs are connected to the columns. Table 2-1 summarizes these connections, and Section 3 covers connecting methods in more detail.

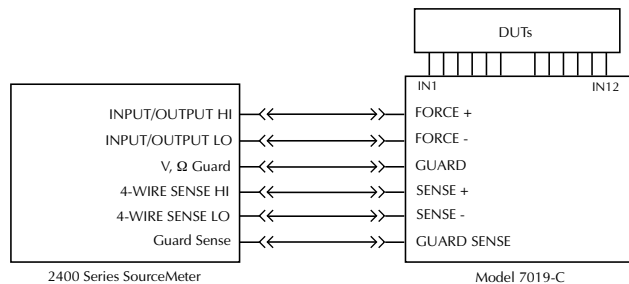

Figure 2-4
Six-wire ohms matrix switching

Table 2-1
SourceMeter matrix connections

SourceMeter jack	Model 7019-C terminal
INPUT/OUTPUT HI	FORCE+
INPUT/OUTPUT LO	FORCE-
V, Ω GUARD	GUARD
4-WIRE SENSE HI	SENSE+
4-WIRE SENSE LO	SENSE-
GUARD SENSE	GUARD SENSE

2.3.2 Utility pathway switching

Figure 2-5 shows typical utility pathway switching. Pathways labeled A and B are connected to Bank D of the mainframe.

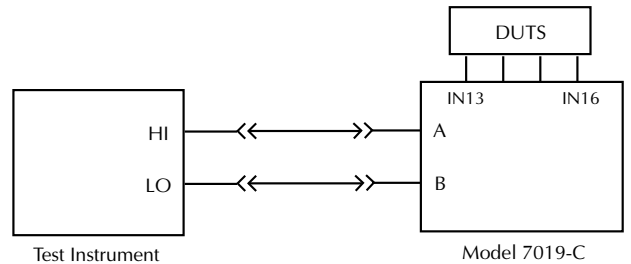

Figure 2-5
Utility pathway switching

2.4 Matrix expansion

With the use of additional matrix cards and mainframes, larger matrices can be configured. Each Model 7001 Switch System mainframe will accommodate up to two cards, and up to six mainframes can be connected together, for a maximum of 12 cards in a 7001/7019-C system. Similarly, each Model 7002 Switch System mainframe can accommodate up to 10 cards, allowing up to 60 Model 7019-C cards in a six mainframe configuration. The limits on the number of cards in the Model 7001 and 7002 Switch Systems are due to triggering.

2.4.1 Isolated switching systems

Two single-card systems can be configured by removing the backplane jumpers from one of the cards. The two cards will be controlled by the same mainframe, but they will be electrically isolated from each other. Figure 2-6 shows an example using two Model 7019-C matrix cards.

2.4.2 Matrix expansion (dual 3x12 matrix)

A dual 3x12 matrix is configured by installing two "as shipped" Model 7019-C cards in the Model 7001 mainframe. By leaving the backplane jumpers installed, the rows of the matrix card installed in slot 1 (CARD 1) are automatically connected to the rows of the matrix card installed in slot 2 (CARD 2) through the analog backplane. The dual 3x12 matrix is shown in Figure 2-7.

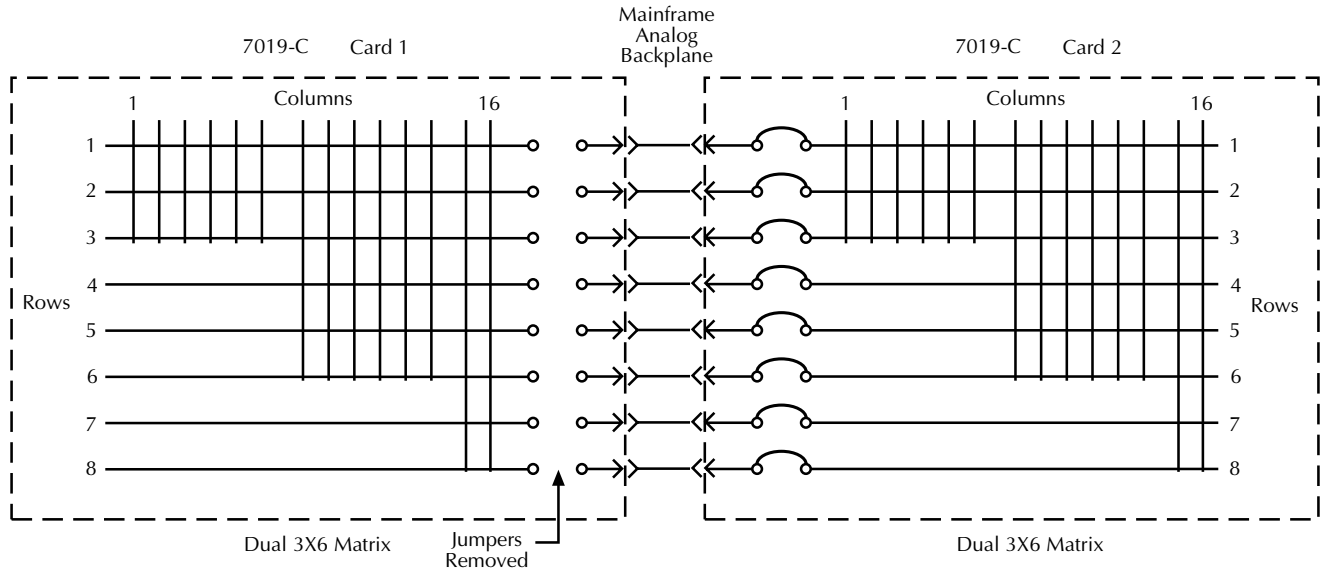

Figure 2-6
Isolated switching system

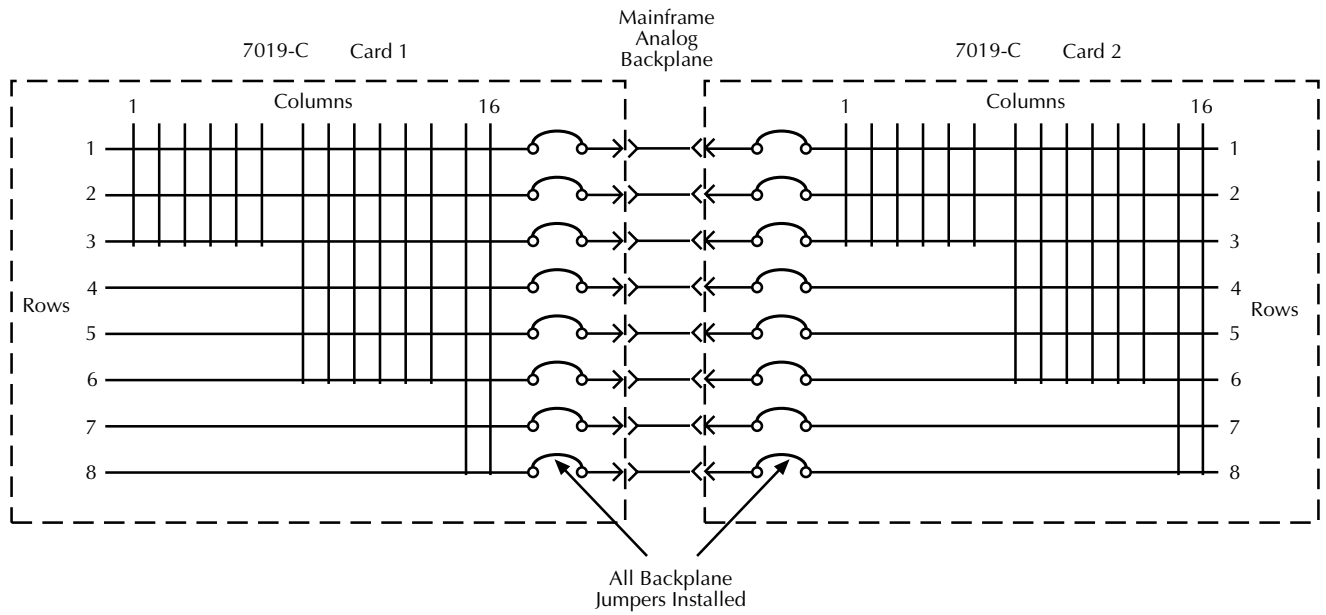

Figure 2-7
Dual 3x12 matrix

3

Card Connections and Installation

3.1 Introduction

This section contains information on making connections to the Model 7019-C and installing the card in a Model 7001 or 7002 switching mainframe.

WARNING

The procedures in this section are intended for qualified service personnel only. Do not perform these procedures unless qualified to do so. Failure to recognize and observe normal safety precautions could result in personal injury or death.

3.2 Handling precautions

To maintain high-impedance isolation, care should be taken when handling the matrix card to avoid contamination from such foreign materials as body oils. Such contamination can substantially lower leakage resistances, thus degrading performance.

- To avoid possible contamination, always grasp the relay and connector cards by the side edges or shields.

- Do not touch the board surfaces or components. Do not touch areas adjacent to the electrical connector contacts. Dirt build-up over a period of time is a possible source of contamination. To avoid this problem, operate the mainframe and matrix card in a clean environment.
- If a card becomes contaminated, it should be thoroughly cleaned as explained in paragraph 5.2.

3.3 Connections

This paragraph provides the basic information needed to connect the SourceMeter and external test circuitry to the matrix card. It also includes information on the installation and removal of the backplane row jumpers on the relay card.

3.3.1 Backplane row jumpers

The Model 7001/7002 mainframe has an analog backplane that allows the rows of a Model 7019-C matrix to be internally connected to another Model 7019-C or other compatible switching card installed in another slot (see paragraph 2.2.1 for details).

The backplane row jumpers for the matrix card assembly are located on the relay card (Figure 3-1). Table 3-1 identifies jumper connections to Model 7019-C and mainframe rows. Note that the card is shipped from the factory with the jumpers installed.

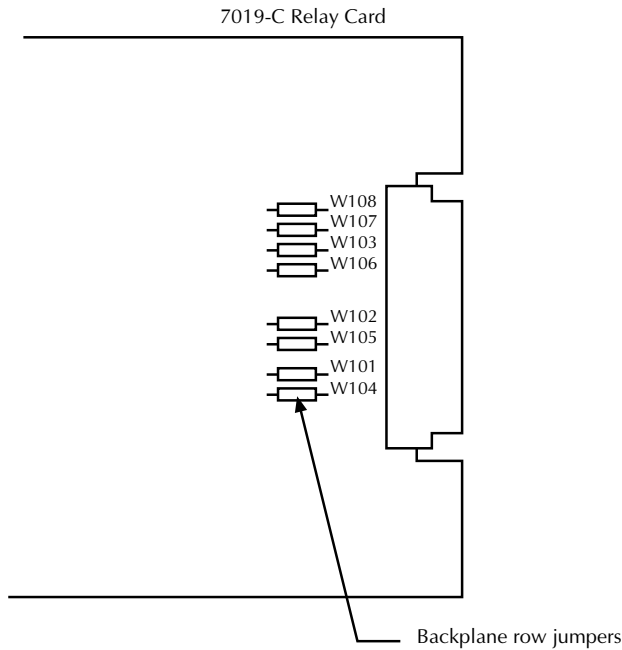

Figure 3-1
Backplane row jumpers

Table 3-1
Backplane jumper identification

Backplane jumper	Model 7019-C row	Mainframe backplane row
W101	FORCE+	Bank A HI
W102	FORCE-	Bank B HI
W103	GUARD	Bank C HI
W104	SENSE+	Bank A LO
W105	SENSE-	Bank B LO
W106	GUARD SENSE	Bank C LO
W107	B	Bank D LO
W108	A	Bank D HI

Jumper removal

Perform the following steps to remove backplane row jumpers:

1. If mated together, separate the relay card from the connector card by removing the mounting screw and then pulling the two cards away from each other. Remember to handle the cards only by the edges and shields to avoid contamination.
2. Use Figure 3-1 to locate the jumper(s) that are to be removed.
3. It is not necessary to physically remove the jumpers from the PC board. Using a pair of wire cutters, cut one lead of each jumper.

Jumper installation

Referring to Figure 3-1 for jumper locations, perform the following steps to install backplane row jumpers:

1. If mated together, separate the relay card from the connector card by removing the mounting screw and then pulling the two cards away from each other. Be sure to handle the cards only by the edges and shields to avoid contamination.
2. Physically remove a cut jumper by unsoldering it from the PC board.
3. Install a new #22 AWG jumper wire (Keithley P/N J-15), and solder it to the PC board.
4. Remove the solder flux from the PC board. The cleaning procedure is explained in paragraph 5.2.

3.3.2 Connector terminal identification

Terminal identification for the DIN connector of the multi-pin connector card is shown in Figure 3-2. This connector will mate to a 96-pin female DIN connector.

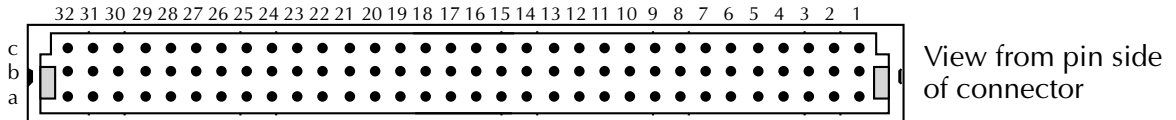

Matrix terminal	Connector designation 1a-32c	Schematic designation 1-96
FORCE +	2c	66
FORCE -	3c	67
GUARD	6c	70
SENSE +	4c	68
SENSE -	5c	69
GUARD SENSE	7c	71
A	9c	73
B	8c	72
IN1	11c	75
IN2	12c	76
IN3	13c	77
IN4	14c	78
IN5	15c	79
IN6	16c	80
IN7	17c	81
IN8	18c	82
IN9	19c	83
IN10	20c	84
IN11	21c	85
IN12	22c	86
IN13	23c	87
IN14	24c	88
IN15	25c	89
IN16	26c	90
Shield pins	9a, 9b	9, 41

Note: Short pins 1a to 1b on the mating connector (pins 1 and 33 on schematic) to allow the output relays on the connector card to close.

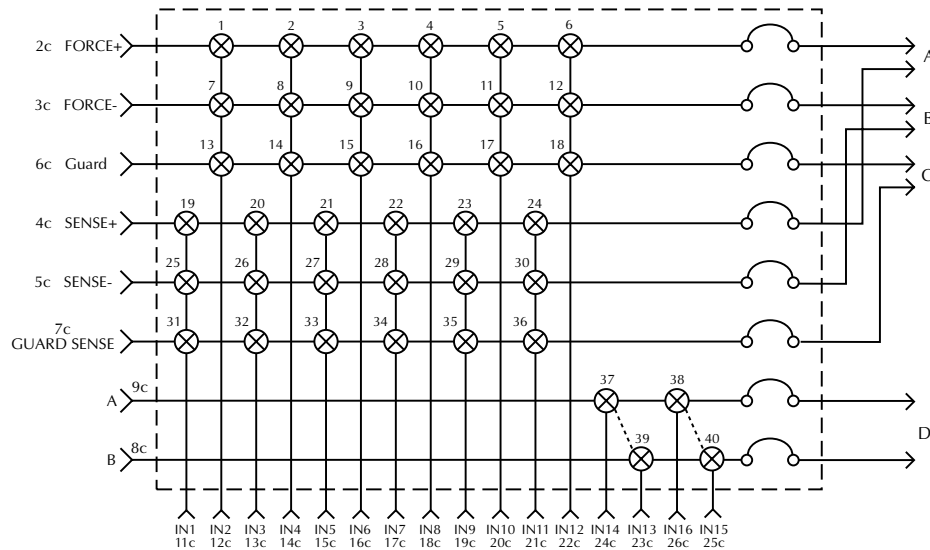

Figure 3-2
Model 7019-C connector terminal identification

Keithley has a variety of cable and connector accessories available to accommodate connections from the connector card to test instrumentation and the DUT. In general, these accessories, which are summarized in Table 3-2, use a round cable assembly for connections.

NOTE

When wiring your test system, be sure to use the connection information summarized in Figure 3-2 instead of the connection listings supplied with the connector accessories.

Table 3-2
Connector accessories

Model	Description
7011-KIT-R	96-pin female DIN connector and housing for round cable.
7011-MTC-2	Two-meter round cable assembly terminated with a 96-pin female DIN connector on each end.
7011-MTR	96-pin male DIN bulkhead connector.

3.3.3 Typical connection techniques

All external circuitry, such as instrumentation and the DUTs, that you wish to connect to the Model 7019-C matrix card must be terminated with a single 96-pin female DIN connector. The following connection techniques provide guidelines and suggestions for wiring your circuitry.

WARNING

Before beginning any wiring procedures, make sure all power is off and any stored energy in external circuitry is discharged.

NOTE

It is recommended that external circuitry be connected (plugged in) after the Model 7019-C assembly is installed in the Model 7001/7002 mainframe and with the mainframe power off. Installation is explained in paragraph 3.5.

Bank connection relays

The Model 7019-C connector card uses connection relays for each of the four banks. These relays are normally open to prevent any hazardous voltages (via the mainframe backplane) from appearing on the pins of the Model 7019-C male DIN connector. The bank connection relays will close only when the Model 7011-MTC-2 cable assembly is connected to the card. If building your own cable assembly, you must make sure that it shorts pins 1a to 1b of the card connector when it is mated to the card. Shorting pins 1a to 1b allows the bank connection relays to close.

Round cable assemblies

Figure 3-3 shows typical round cable connection techniques using accessories available from Keithley. In Figure 3-3A, connections are made using a Model 7011-MTC-2 cable and a Model 7011-MTR bulkhead connector. The two-meter round cable is terminated with a 96-pin female DIN connector at each end. This cable mates directly to the Model 7019-C connector and to the bulkhead connector. The bulkhead connector has solder cups to allow direct connection to instrumentation and DUT. Figure 3-4 provides pinout for the bulkhead connector. The view shown is from the solder cup end of the connector.

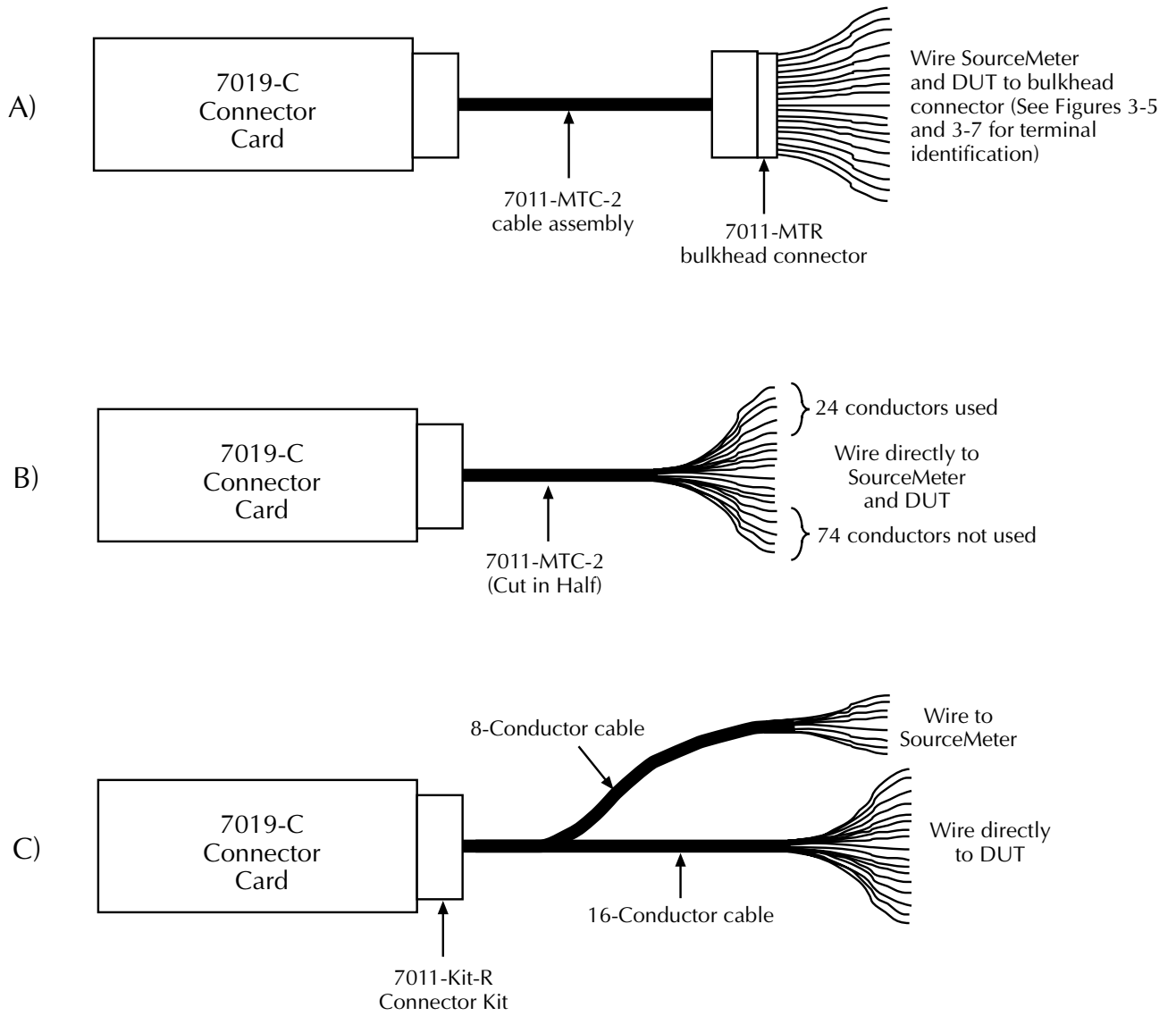

Note: Figure 3-5 provides an exploded view showing how the connector (with cable) is assembled.

Figure 3-3
Typical round cable connection techniques

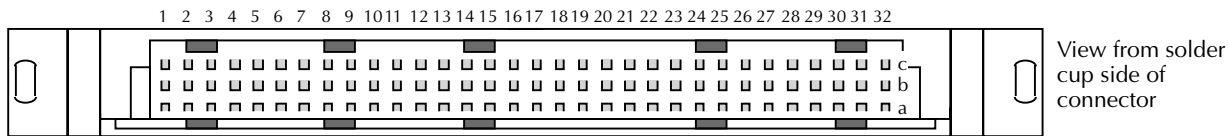

Note : See Figure 3-2 for terminal identification.

Figure 3-4
Model 7011-MTR connector pinout

In Figure 3-3B, connections are made using a Model 7011-MTC-2 cable assembly that is cut in half. The 96-pin female DIN connector on one end of the cable mates directly to the multi-pin connector card. The unterminated end of the cable is wired directly to the SourceMeter and the DUT. The other half of the cable assembly could be used for a second switching card.

In Figure 3-3C, connections are made using a custom-built cable assembly that consists of a Model 7011-KIT-R connector and 8-conductor and 16-conductor cables. The connector has solder cups to accommodate the individual wires of the unterminated cable. Figure 3-5 provides an exploded view of the connector assembly and shows how the cables are connected. The connector end of the resulting cable assembly mates directly to the multi-pin connector card. The unterminated end of the cable assembly is wired directly to instrumentation and the DUT.

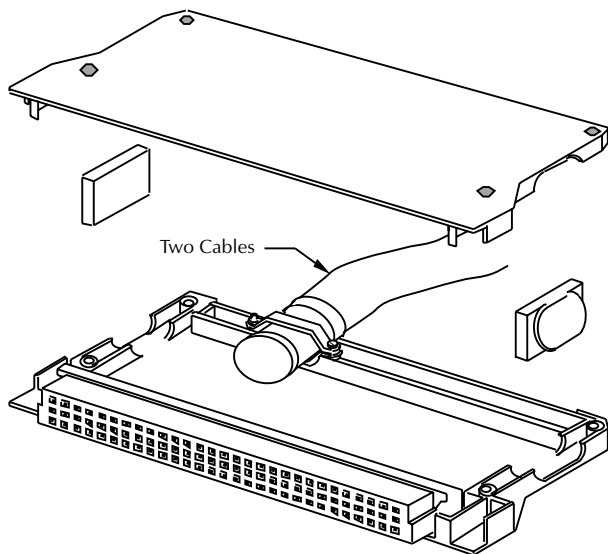

Figure 3-5
Model 7011-KIT-R assembly, shown with cables

3.3.4 Connector insulation and cleaning

To ensure adequate isolation resistance between signal lines, observe the following precautions when wiring connectors:

- Install a short length of Teflon[®] tubing on each connecting wire and connector terminal. Be sure the tubing is of sufficient length to cover both the terminal and the exposed end of the wire.
- After soldering all wires to the connector, thoroughly wash the entire connector with distilled water followed by clean methanol. Allow the connector to dry for several hours in a 50°C low-humidity environment before use.
- After cleaning and drying, slide each piece of Teflon[®] tubing down until it completely covers the connector terminal.

3.4 Typical connection schemes

The following information provides some typical connection schemes for single-card and multi-card system configurations using the series 2400 SourceMeters to make six-wire ohms measurements. Remember that these are only examples to demonstrate various ways to wire a test system. Connection details are provided in paragraph 3.3.

3.4.1 Single-card system

Figure 3-6 shows how external connections can be made to a single-card system. The SourceMeter and the DUTs are hard-wired to the Model 7011-MTR male bulkhead connector. This connector has solder cups that will accept wire sizes up to #24 AWG. The test system is connected to the matrix using the Model 7011-MTC-2 round cable assembly. This cable mates directly to both the external bulkhead connector and the Model 7019-C matrix card assembly. Notice that the bulkhead connector is shown mounted to a fixture to help keep the cabling stable during the test.

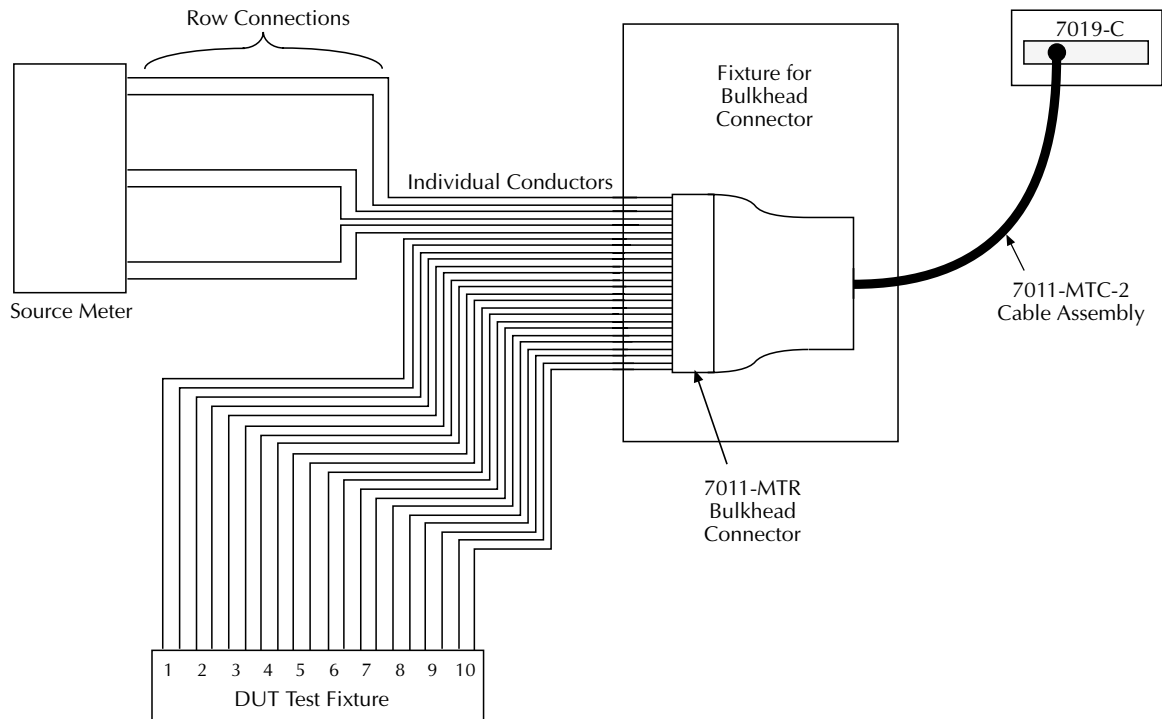

Figure 3-6
Single-card system example

When using a single card-system, make sure the card remains electrically isolated from any other switching cards installed in the same mainframe. There are several ways to ensure isolation for a single card in the Model 7001/7002 mainframe:

- Vacate other mainframe slot(s). If there is a Model 701X card installed in another slot, remove it.
- Remove all backplane jumpers on the Model 7019-C matrix card. Doing so will disconnect the card from the analog backplane of the mainframe.
- Remove all backplane jumpers from any switching card(s) installed in other slot(s).

3.4.2 Multi-card system

Figure 3-7 shows a system using two matrix cards installed in one Model 7001 mainframe to configure a dual 3×12 test matrix. In this connection scheme, row connections of the two matrix cards are made internally through the backplane of the

Model 7001 mainframe. As previously discussed, the backplane row jumpers of both matrix cards must be installed.

Figure 3-7 shows how external connections can be made for each Model 7019-C card. In this example, a single Model 7011-MTC-2 round cable assembly is cut in half to provide two cables, each of which is unterminated at one end. The unterminated ends of one of the cables are hard-wired to the SourceMeter and some of the DUTs, while the other cable is connected to the remainder of the DUTs, as shown. The connector ends of these cables mate directly to the Model 7019-C matrix card assemblies.

The same general connecting scheme shown in Figure 3-7 can be used for larger matrices by installing several Model 7019-C cards in a Model 7002 mainframe. Again, the SourceMeter should be connected to the row terminals of only one card connector, while DUT connections are made to the column terminals of all card connectors in the matrix. Backplane jumpers for all cards must also be installed to carry row connections through to all cards in the matrix.

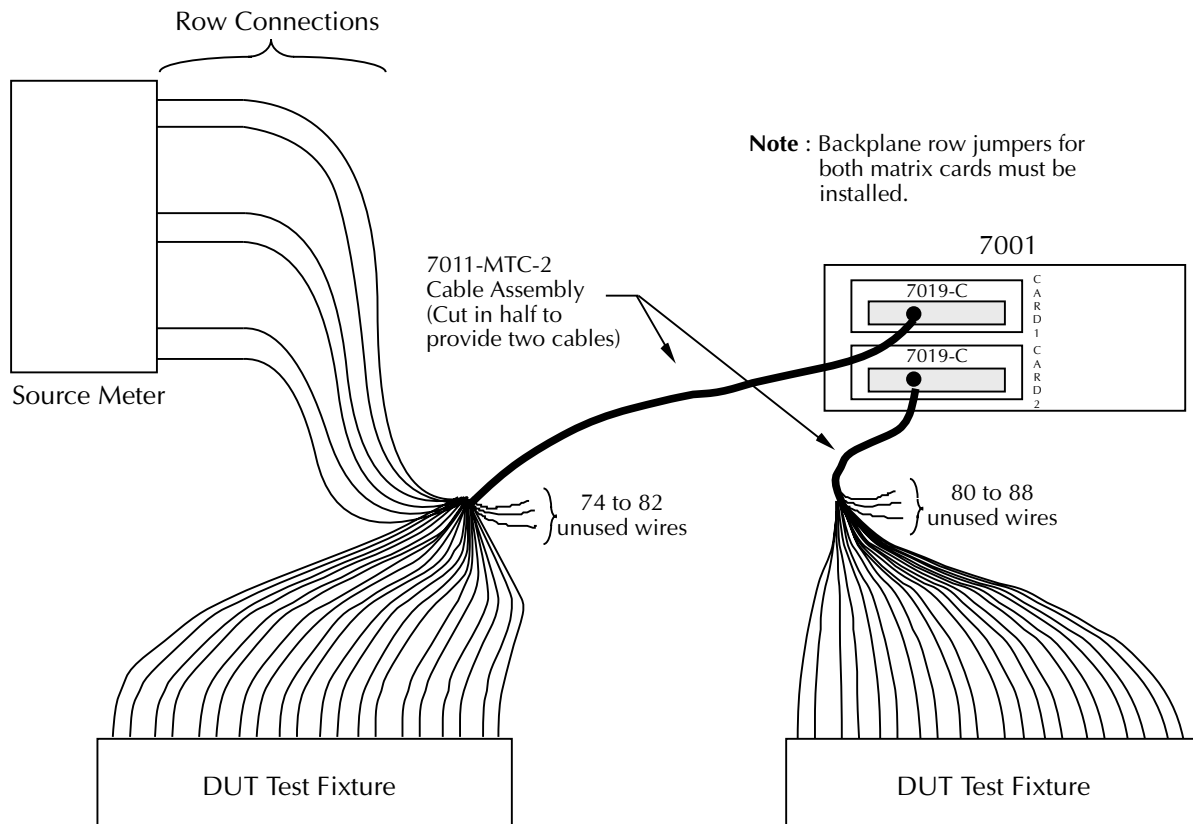

Figure 3-7
Two-card system connection example

3.5 Model 7019-C installation and removal

The following paragraphs explain how to install and remove the Model 7019-C matrix card assembly from the Model 7001/7002 mainframe.

WARNING

Installation or removal of the Model 7019-C should be performed by qualified service personnel only. Failure to recognize and observe standard safety precautions could result in personal injury or death.

CAUTION

To prevent contamination of the matrix card that could degrade performance, handle the card assembly by the edges and shields only.

3.5.1 Matrix card installation

Perform the following steps to install the Model 7019-C matrix card assembly in the Model 7001/7002 mainframe:

WARNING

Turn off power from all instrumentation (including the Model 7001/7002 mainframe) and disconnect their line cords. Make sure all power is removed and stored energy in external circuitry is discharged. Disconnect the 96-pin connector cable from the card before installation or removal.

1. Mate the connector card to the relay card if they are separated. Install the supplied 4-40 screw at the end of the card to secure the assembly. Make sure to handle the cards by the edges and shields to prevent contamination.

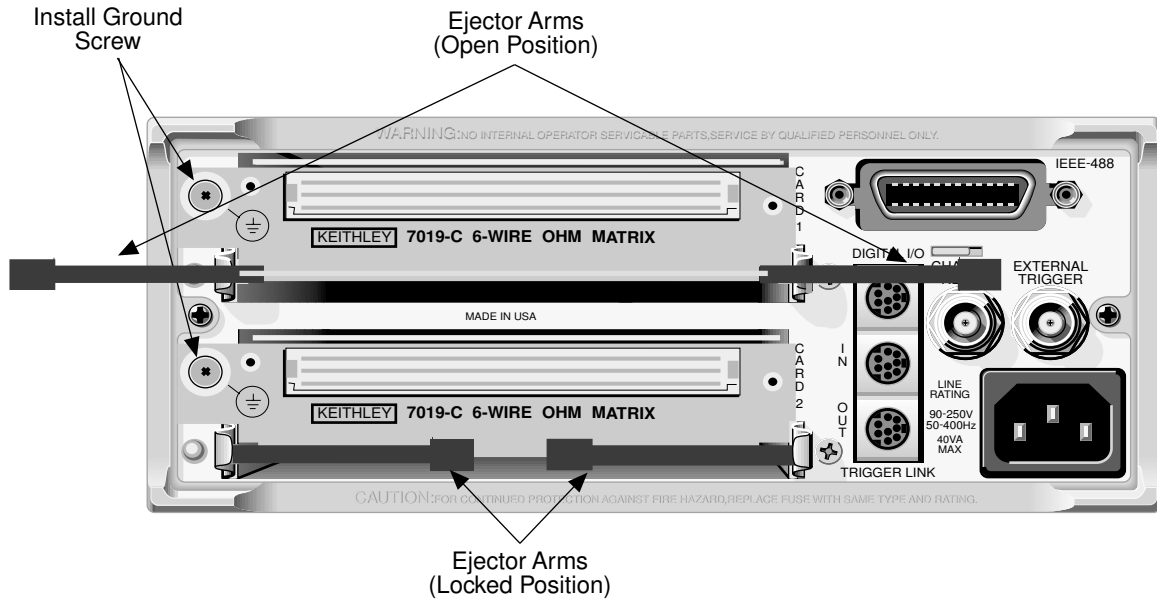

Figure 3-8
Model 7019-C installation in Model 7001

2. Facing the rear panel of the Model 7001 or 7002, select the slot in which you wish to install the card.
3. Referring to Figure 3-8 for Model 7019-C installation in the Model 7001 or Figure 3-9 for Model 7019-C installation in the Model 7002, feed the matrix card assembly into the desired slot so the edges of the relay card ride in the rails.
4. With the ejector arms in the unlocked position, push the card assembly all the way into the mainframe until the arms engage into the ejector cups, and then push both arms inward to lock the card into the mainframe.
5. Install the screw as shown in Figure 3-8 or Figure 3-9.

3.5.2 Matrix card removal

To remove the matrix card assembly, remove the ground screw, unlock the card by pulling the latches outward, and then pull the card assembly out of the mainframe. Remember to handle the card assembly by the edges and shields to avoid contamination that could degrade performance.

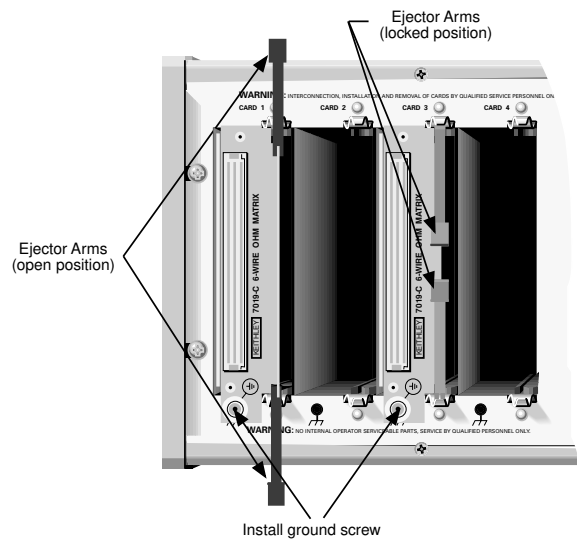

Figure 3-9
Model 7019-C installation into Model 7002

4

Operation

4.1 Introduction

This section contains basic operating information for the Model 7019-C. For detailed mainframe operating instructions, refer to the Model 7001 or 7002 Instruction Manual.

4.2 Safety and signal considerations

4.2.1 Safety considerations

WARNING

Applying a voltage to the mainframe backplane that is higher than the Model 7019-C voltage specification may cause the Model 7019-C output relay contacts to permanently short together. This situation may cause hazardous voltages from other cards in the mainframe to appear on the Model 7019-C 96-pin connector terminals. To avoid a possible shock hazard:

- Limit the backplane voltage to the lowest voltage rating of all cards in the system.
- Remove all unused cards from the mainframe.
- Make sure all connectors are fully mated before applying power.
- All connections including external connections must be fully insulated or shielded to prevent operator contact. Safety shields must be connected to safety earth ground using #18 AWG or larger wire.

4.2.2 Maximum signal levels

CAUTION

To prevent damage to the card, do not exceed the maximum signal level specifications of the card.

To prevent overheating or damage to the relays, never exceed the following maximum signal levels:

- Maximum voltage: 200V peak.
- Maximum current: 1A carry, 0.5A switched.
- Maximum power: 10VA

4.2.3 Maximizing relay life

For maximum relay life, use cold switching whenever possible. With cold switching, power is removed from the crosspoint being switched before the corresponding relay is opened or closed.

The 2400 series of SourceMeters have a pulse trigger mode that can be used in conjunction with Model 7001/7002 triggering to perform cold switching automatically. With this mode, the SourceMeter will turn off its output and then trigger the Model 7001/7002 to close or open crosspoints. The SourceMeter will then turn on its output and make the measurement as usual. See the respective instrument instruction manuals for details on triggering.

4.3 Mainframe control of matrix card

The following information pertains to the Model 7019-C matrix card. It assumes you are familiar with the operation of the Model 7001/7002 mainframe.

If you are not familiar with the operation of the mainframe, refer to Section 3 of the Model 7001 or 7002 Instruction Manual after reading the following information.

7001 Display

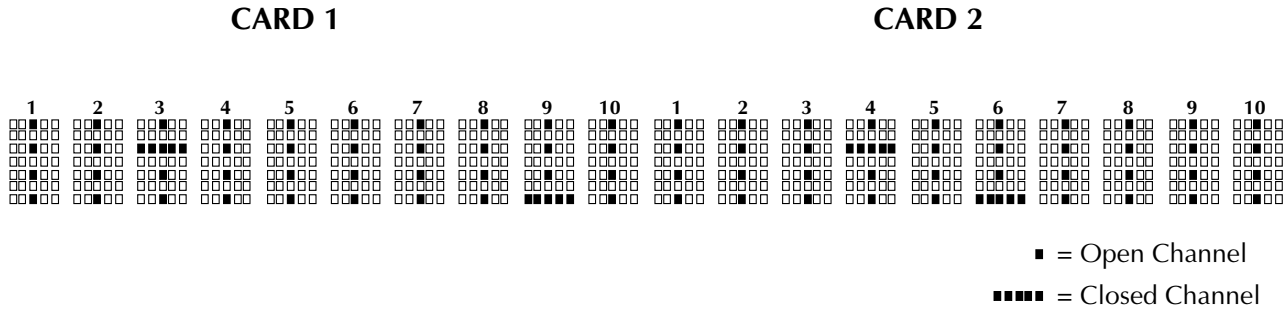

Figure 4-1
Channel status display

4.3.1 Channel assignments

Mainframe display format

The Model 7001 has a channel status display (Figure 4-1) that provides the real-time state of each available channel. The left portion of the display is for slot 1 (Card 1), and the right portion is for slot 2 (Card 2).

The Model 7002 has a similar display but includes indicators for 10 cards.

Controlling crosspoints

Each Model 7019-C matrix card crosspoint is accessed by using a specific CHANNEL number (1-40) that identifies a unique crosspoint. The CHANNEL assignments for the matrix card are summarized in Figure 4-2 and are listed in detail in Table 4-1.

Each CHANNEL assignment is made up of the slot designator (1 or 2 for the Model 7001; 1 through 10 for the Model 7002) and the channel number for the crosspoint. When controlling crosspoints, include both the slot and the channel number separated by an exclamation point. Some examples of CHANNEL assignments for specific crosspoints are:

- CHANNEL 1!1 = Slot 1, Channel 1 (IN2, FORCE+)
- CHANNEL 1!12 = Slot 1, Channel 12 (IN12, FORCE-)
- CHANNEL 2!21 = Slot 2, Channel 21 (IN5, SENSE+)
- CHANNEL 2!33 = Slot 2, Channel 33 (IN5, GUARD SENSE)

C1 IN2, F+	C2 IN4, F+	C3 IN6, F+	C4 IN8, F+	C5 IN10, F+	C6 IN12, F+	C7 IN2, F-	C8 IN4, F-	C9 IN6, F-	C10 IN8, F-
C11 IN10, F-	C12 IN12, F-	C13 IN2, G	C14 IN4, G	C15 IN6, G	C16 IN8, G	C17 IN10, G	C18 IN12, G	C19 IN1, S+	C10 IN3, S+
C21 IN5, S+	C22 IN7, S+	C23 IN9, S+	C24 IN11, S+	C25 IN1, S-	C26 IN3, S-	C27 IN5, S-	C28 IN7, S-	C29 IN8, S-	C30 IN11, S-
C31 IN1, GS	C32 IN3, GS	C33 IN5, GS	C34 IN7, GS	C35 IN9, GS	C36 IN11, GS	C37 IN14, A	C38 IN6, A	C39 IN13, B	C40 IN15, B

Key: C = Channel #
F = FORCE
S = SENSE
G = Guard
GS = GUARD SENSE
IN = Column Input #

Figure 4-2
Model 7019-C card channel/crosspoint assignments

Table 4-1
Crosspoint channel assignments

Model 7001/7001 channel number	Model 7019-C crosspoint*
1	IN2, FORCE+
2	IN4, FORCE+
3	IN6, FORCE+
4	IN8, FORCE+
5	IN10, FORCE+
6	IN12, FORCE+
7	IN2, FORCE-
8	IN4, FORCE-
9	IN6, FORCE-
10	IN8, FORCE-
11	IN10, FORCE-
12	IN12, FORCE-
13	IN2, GUARD
14	IN4, GUARD
15	IN6, GUARD
16	IN8, GUARD
17	IN10, GUARD
18	IN12, GUARD
19	IN1, SENSE+
20	IN3, SENSE+
21	IN5, SENSE+
22	IN7, SENSE+
23	IN9, SENSE+
24	IN11, SENSE+
25	IN1, SENSE-
26	IN3, SENSE-
27	IN5, SENSE-
28	IN7, SENSE-
29	IN9, SENSE-
30	IN11, SENSE-
31	IN1, GUARD SENSE
32	IN3, GUARD SENSE
33	IN5, GUARD SENSE
34	IN7, GUARD SENSE
35	IN9, GUARD SENSE
36	IN11, GUARD SENSE
37	IN14, A
38	IN16, A
39	IN13, B
40	IN15, B

* Indicates which row and column are connected by closing channel.

4.3.2 Front panel control

A Model 7019-C crosspoint is closed from the front panel by keying in the channel assignment and pressing CLOSE. For example, to close the IN4, FORCE- crosspoint (channel 8) of a Model 7019-C card installed in slot 2, key in the following channel list, and press CLOSE:

```
SELECT CHANNELS 2!8
```

The above closed channel can be opened by pressing OPEN or OPEN ALL. The OPEN key opens only the channels specified in the channel list, and the OPEN ALL key opens all channels.

The following display is an example of a channel list that closes six channels required for a typical 6-wire ohms measurement:

```
SELECT CHANNELS 1!1,1!8,1!15,1!19,1!26,1!33
```

Notice that channel entries are separated by commas (,). A comma is inserted by pressing ENTER or the right cursor key. The channel range is specified by using the hyphen key to separate the range limits. Pressing CLOSE will close all the channels specified in the channel list. Pressing OPEN (or OPEN ALL) will open the channels.

4.3.3 IEEE-488 bus operation

The following SCPI commands are used to close and open channels:

```
:CLOSE <list>  
:OPEN <list>!ALL
```

For example, the following command closes channels 1!1, 1!8, and 1!15:

```
:CLOS (@1!1,1!8,1!15)
```

Either of the following commands will open channels 1!1, 1!8, and 1!15:

```
:OPEN (@1!1,1!8,1!15)  
:OPEN ALL
```

4.3.4 Automatic crosspoint sequencing

You can automatically sequence through Model 7019-C crosspoint configurations by using the Model 7001/7002 switch pattern memory. The Model 7001 can store up to 100 switch patterns, and the Model 7002 can store 500 switch patterns. See the Model 7001 or 7002 Instruction Manual for details.

4.4 Measurement considerations

Many measurements made with the Model 7019-C are subject to various effects that can seriously affect six-wire ohms measurement accuracy. The following paragraphs discuss these effects and ways to minimize them.

4.4.1 Path isolation

Path isolation is the equivalent impedance between any two test paths in a measurement system. Ideally, the path isolation should be infinite, but the actual resistance and distributed capacitance of cables and connectors results in less than infinite path isolation values for these devices. For six-wire ohms measurements using the series 2400 SourceMeters, only the resistive component of isolation impedance is of any consequence, and the capacitive component need not normally be considered.

Path isolation resistance forms a signal path that is in parallel with the equivalent resistance of the DUT, as shown in Figure 4-3. For low-to-medium device resistance values, path isolation resistance is seldom a consideration. However, it can degrade measurement accuracy when testing high-resistance devices.

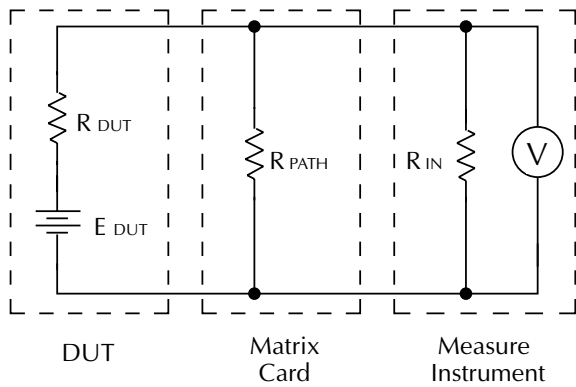

- R_{DUT} = Source Resistance of DUT
- E_{DUT} = Source EMF of DUT
- R_{PATH} = Path Isolation Resistance
- R_{IN} = Input Resistance of Measuring Instrument

Figure 4-3
Path isolation resistance

4.4.2 Magnetic fields

When a conductor cuts through magnetic lines of force, a very small current is generated. This phenomenon will often cause unwanted signals to occur in the test leads of a switching matrix system. If the conductor has sufficient length, even weak magnetic fields like those of the earth can create sufficient signals to affect low-level measurements.

Two ways to reduce these effects are: (1) reduce the lengths of the test leads, and (2) minimize the exposed circuit area. In extreme cases, magnetic shielding may be required. Special metal with high permeability at low flux densities (such as mu metal) is also effective.

Even when the conductor is stationary, magnetically-induced signals may still be a problem. Fields can be produced by various signals such as the AC power line voltage. Large inductors such as power transformers can generate substantial magnetic fields, so care must be taken to keep the switching and measuring circuits away from these potential noise sources.

At high current levels, even a single conductor can generate significant fields. These effects can be minimized by using twisted pairs, which will cancel out most of the resulting fields.

4.4.3 Radio frequency interference

RFI (Radio Frequency Interference) describes electromagnetic interference over a wide range of frequencies across the spectrum. Such RFI can be particularly troublesome at low signal levels, but it can also affect measurements at high levels if the problem is sufficiently severe.

RFI can be caused by steady-state sources such as radio or television signals, or some types of electronic equipment (microprocessors, high speed digital circuits, etc.). It can also result from impulse sources, as in the case of arcing in high-voltage environments. In either case, the effect on the measurement can be considerable if enough of the unwanted signal is present.

RFI can be minimized in several ways. The most obvious method is to keep the equipment and signal leads as far away from the RFI source as possible. Shielding the matrix switching card, signal leads, sources, and SourceMeter will often reduce RFI to an acceptable level. Again, shields should normally be connected only at one end, either to ground or circuit common, depending on which configuration gives the best results.

The series 2400 SourceMeters incorporate internal filtering that may help to reduce RFI effects in many situations. Note, however, that filtering will reduce the reading rate, possibly affecting the throughput of a production testing environment.

4.4.4 Ground loops

When two or more instruments are connected together, care must be taken to avoid unwanted signals caused by ground loops. Ground loops usually occur when sensitive instrumentation is connected to other instrumentation with more than one signal return path such as power line ground. As shown in Figure 4-4, the resulting ground loop causes current to flow through the instrument LO signal leads and then back through power line ground. This circulating current develops a small but undesirable voltage between the LO terminals of the two instruments. This voltage will be added to the source voltage, affecting the accuracy of the measurement.

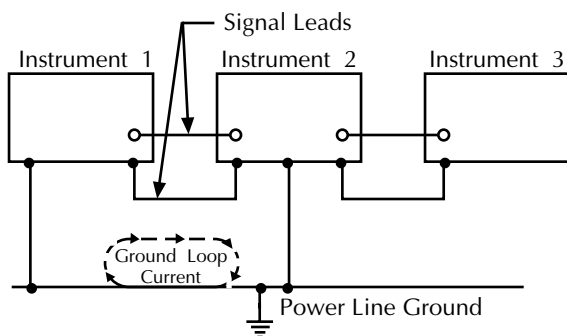

Figure 4-4
Ground loops

Figure 4-5 shows how to connect several instruments together to eliminate this type of ground loop problem. Here, only one instrument is connected to power line ground.

Ground loops are not normally a problem with instruments having isolated LO terminals such as the series 2400 SourceMeters. However, as stated previously, shields should normally be connected to ground or circuit common at one end to avoid such ground loops.

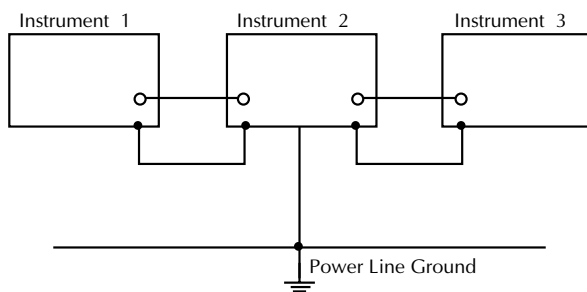

Figure 4-5
Ground loop elimination connections

4.4.5 Keeping connectors clean

As is the case with any high-resistance device, the integrity of the 96-pin connectors can be compromised if they are not handled properly. If connector insulation becomes contaminated, the insulation resistance will be substantially reduced, affecting high-impedance measurement paths.

Oils and salts from the skin can contaminate connector insulators, reducing their resistance. Also, contaminants present in the air can be deposited on the insulator surface. To avoid these

problems, never touch the card or mating 96-pin connector insulating material. In addition, the matrix card should only be used in clean, dry environments to avoid contamination.

If the connector insulators become contaminated, they can be cleaned with a cotton swab dipped in clean methanol. After thoroughly cleaning, they should be allowed to dry for several hours in a low-humidity environment before use, or they can be dried more quickly using dry nitrogen.

4.5 Six-wire ohms resistance testing applications

The Model 7019-C is designed specifically for use with the six-wire ohms function of the series 2400 SourceMeters. The following information provides an overview of using the Model 7019-C for six-wire ohms testing of resistor networks using a Model 2400 SourceMeter.

4.5.1 Types of resistor networks

Figure 4-6 shows the various types of resistor networks. These include bussed networks, isolated networks, dual terminator networks, and ladder networks.

Bussed networks

Bussed networks (Figure 4-6A) usually contain resistors of the same value connected to a common bus. These networks are often used for pull-up/pull-down or impedance-matching applications. The Model 7019-C provides multiplexing of these device pins to the 2 or 4-wire inputs of any 2 or 4-wire measuring instrument.

Isolated networks

Isolated networks (Figure 4-6B) typically contain resistors of the same value. The resistors in the network are electrically isolated from each other. Typical applications for these types of networks include current-limiting and termination. Again, the Model 7019-C provides 2 or 4-wire multiplexing.

Dual terminator networks

Dual terminator networks (Figure 4-6C) are generally constructed with resistors of two different values, with each resistor connected to a common bus. The resistors within the network form equivalent circuits, often called delta or loop circuits, that are in parallel with the individual resistor. The Model 7019-C provides easy multiplexing of these devices to a six-wire measuring instrument such as the Model 2400 using guard to guard out the parallel path.

Ladder networks

Ladder networks (Figure 4-6D) typically contain resistors of two values, with one value being twice the other. For that reason, these networks are usually referred to as R/2R ladders and are commonly found in A/D and D/A applications. These ladders often have “buried” nodes or junctions without external access pins. In such cases, a “split Kelvin” connection scheme to a 4-wire measuring instrument such as the series 2400 is required. The Model 7019-C provides convenient switching of these connections.

4.5.2 Typical resistor network tests

Typical tests performed on resistor networks include:

- Measurement of element resistance values.
- Measurement of isolation resistance between individual elements.
- Determination of voltage coefficient, which is change in resistance with applied voltage.

4.5.3 Six-wire ohms measurement technique

Conventional two-wire or four-wire resistance measurement techniques cannot be used on some resistor networks because it is not possible to make appropriate connections to individual elements within the network. In such networks, three or more resistors are connected in a delta loop, forming a Thevenin equivalent circuit. The usual two-wire or four-wire measurement technique will yield the resistance of the Thevenin equivalent circuit rather than the resistance of each element.

The six-wire guarded ohms measurement technique shown in Figure 4-7 solves the problem by effectively guarding or nulling out the unwanted resistances. For example, assume that the resistance of R_1 is to be determined. Normally, R_2 and R_3 would appear in parallel with R_1 , reducing its measured value. Applying the guard voltage to the junction of R_2 and R_3 effectively removes R_2 and R_3 from the circuit, and the resistance of R_1 is determined in the usual manner by forcing the source current I_S through R_1 , and then measuring the resulting voltage across the device in order to compute the resistance. Note that each of the six SourceMeter terminal connections is routed through a Model 7019-C crosspoint. Crosspoint connections can be changed as desired to test the various elements within the network.

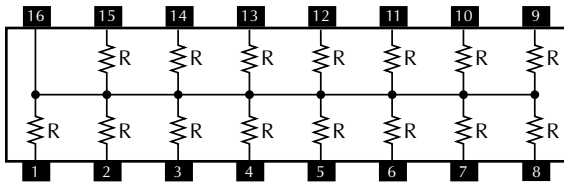

A. Bussed

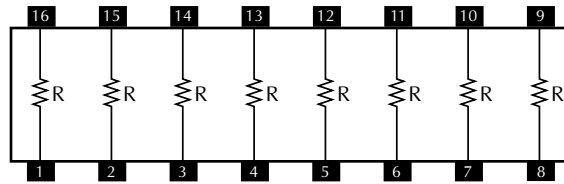

B. Isolated

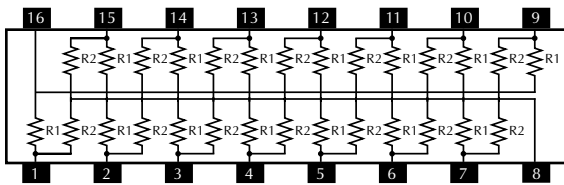

C. Dual terminator

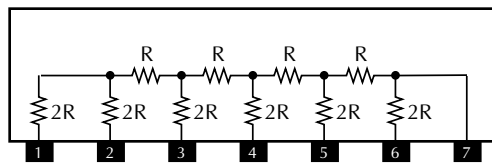

D. Ladder with "buried" nodes

Figure 4-6
Types of resistor networks

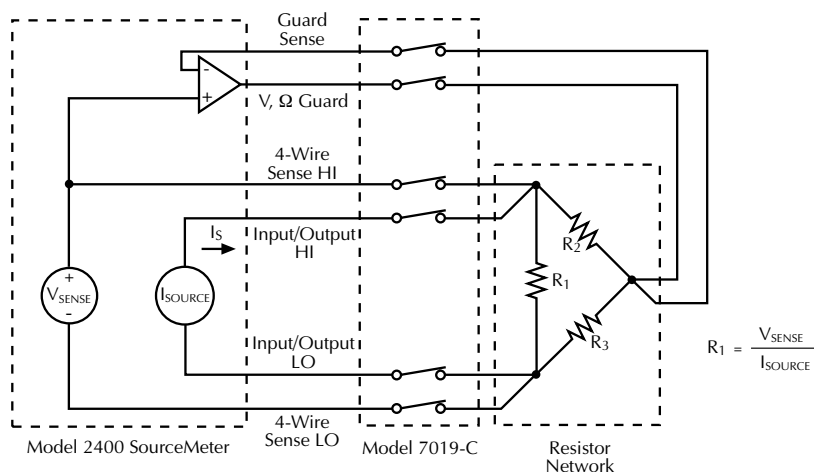

Figure 4-7
Six-wire ohms guarded measurement technique

4.5.4 Six-wire ohms test switching connections

Figure 4-8 shows the basic connections, using a Model 2400 SourceMeter and the Model 7019-C, to make six-wire ohms measurements on resistor networks.

SourceMeter and matrix card connections

The six rear panel jacks of the SourceMeter are connected to the Model 7019-C rows summarized in Table 4-2.

Table 4-2
SourceMeter and matrix card connections

Model 2400 jack	Model 7019-C row terminal
INPUT/OUTPUT HI	FORCE+
INPUT/OUTPUT LO	FORCE-
V, Ω GUARD	GUARD
4-WIRE SENSE HI	SENSE+
4-WIRE SENSE LO	SENSE LO
GUARD SENSE	GUARD SENSE

Resistor network connections

The resistor network terminals should be connected to the twelve column terminals (IN1 through IN12) of the Model 7019-C. The exact connecting scheme will depend on the resistor network configuration.

4.5.5 Basic six-wire ohms test procedure

The basic procedure for making resistor network measurements using the Model 2400 SourceMeter and the Model 7019-C for six-wire ohms measurements on resistor networks is:

1. Connect the SourceMeter and resistor network to the Model 7019-C using Figures 4-7 and 4-8 as a guide.
2. Configure the SourceMeter for six-wire ohms measurements, and be sure the rear panel jacks are selected.
3. Program the switching mainframe to close the necessary Model 7019-C crosspoints to test the desired network resistance element.
4. Turn on the Model 2400 source output.
5. Make the resistance measurement for the selected element.
6. Turn off the Model 2400 source.
7. Program the switching mainframe to open the crosspoints presently closed.
8. Repeat steps 3 through 7 for each network element to be tested.

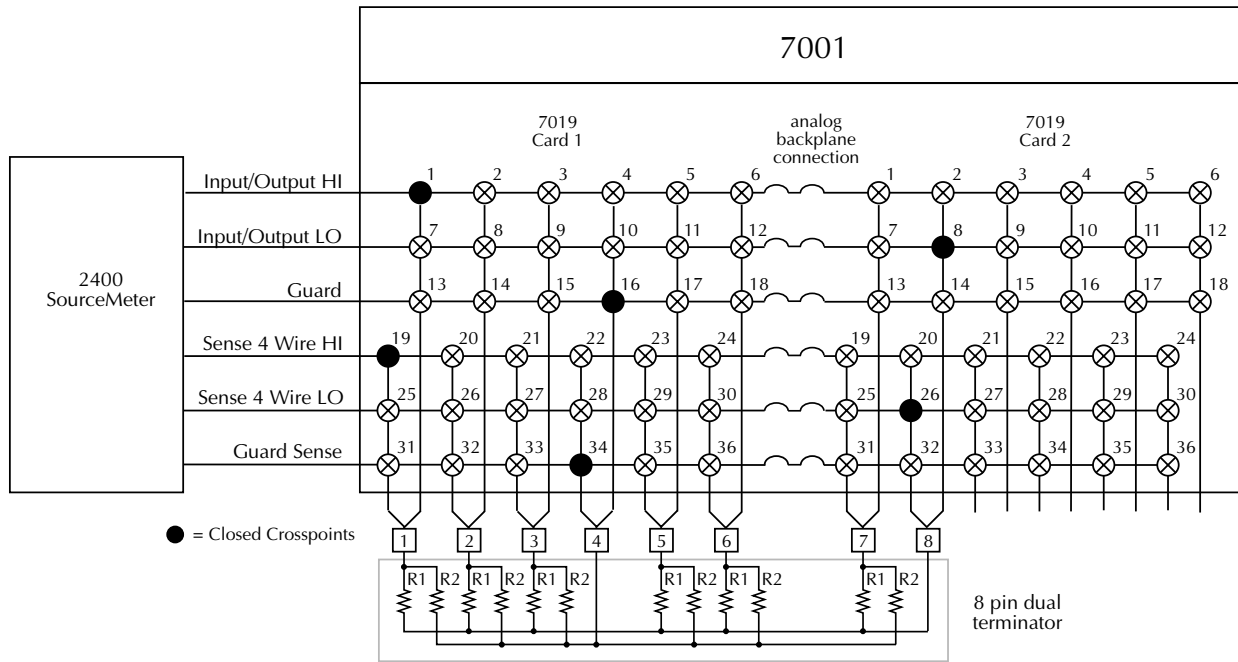

Figure 4-8
Six-wire ohms test connections

4.5.6 Split Kelvin measurement technique

Conventional 2-wire or 4-wire resistance measurement techniques cannot be used to test resistors with “buried” nodes such as the ladder network shown in Figure 4-6D. In such networks, the usual solution is to use a split Kelvin connection, where the source and sense lines are connected to different points on the network.

Figure 4-9 shows the basic circuit configuration for the split Kelvin measurement technique. In this example, connections allow the value of R_3 to be determined. The source current flows through R_3 , developing a voltage across that resistance element, and the resistance value is computed from the sourced current and measured voltage in the usual manner. Note that the measured voltage is essentially the same as the voltage across R_3 because the sense current through R_1 and R_5 is negligible.

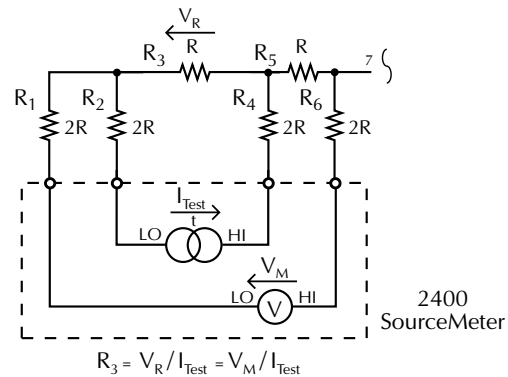

Figure 4-9
Split Kelvin measurement technique

4.5.7 Split Kelvin test connections

Figure 4-10 shows the basic connections using a Model 2400 SourceMeter and the Model 7019-C to make the split Kelvin resistance measurement previously described.

4.5.8 Basic test procedure

The basic procedure for making split Kelvin resistor network measurements using the Model 2400 SourceMeter and Model 7019-C is:

1. Connect the SourceMeter and resistor network to the Model 7019-C using Figures 4-9 and 4-10 as a guide.

2. Configure the SourceMeter for four-wire ohms measurements.
3. Program the switching mainframe to close the necessary Model 7019-C crosspoints to test the desired network resistance element.
4. Turn on the Model 2400 source output.
5. Make the resistance measurement for the selected element.
6. Turn off the Model 2400 source.
7. Program the switching mainframe to open the crosspoints presently closed.
8. Repeat steps 3 through 7 for each network element to be tested.

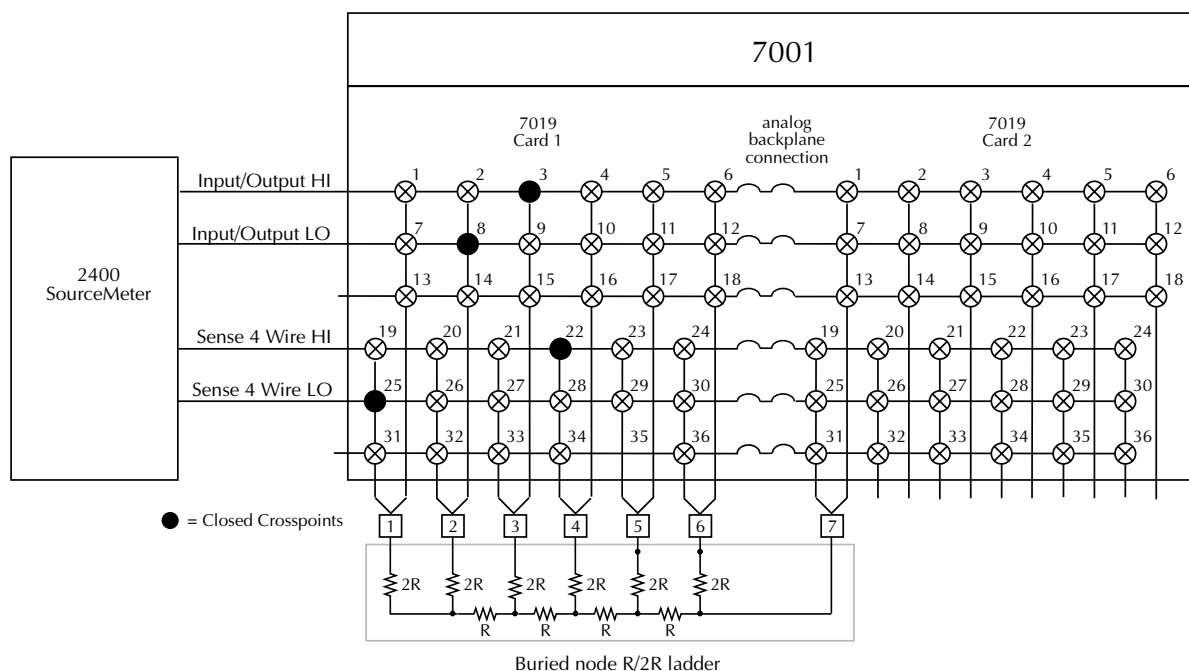

Figure 4-10
Split Kelvin test connections

5

Servicing

5.1 Introduction

This section contains information necessary to service the Model 7019-C matrix card.

WARNING

The information in this section is intended for qualified service personnel only. Some of the procedures may expose you to hazardous voltages that could result in personal injury or death. Do not attempt to perform these procedures unless qualified to do so.

5.2 Handling and cleaning precautions

Because of the high-impedance circuits on the Model 7019-C, care should be taken when handling or servicing the card to prevent possible contamination, which could degrade performance. The following precautions should be taken when handling the matrix card.

- Do not store or operate the card in an environment where dust could settle on the circuit board. Use dry nitrogen gas to clean dust off the card if necessary.
- Handle the card only by the side edges. Do not touch any board surfaces, components, or connectors. Do not touch areas adjacent to electrical contacts. When servicing the card, wear clean cotton gloves.

- If making solder repairs on the circuit board, use an OA-based (organic activated) flux. Remove the flux from these areas when the repair is complete. Use pure water and clean cotton swabs to remove the flux. Take care not to spread the flux to other areas of the circuit board. Once the flux has been removed, swab only the repaired area with methanol, and then blow-dry the board with dry nitrogen gas.
- After cleaning, the card should be placed in a 50°C low humidity environment for several hours before use.

5.3 Performance verification

The following paragraphs discuss performance verification procedures for the Model 7019-C, including path resistance, offset current, and isolation.

With the Model 7019-C backplane jumpers installed, the performance verification procedures must be performed with only one matrix card (the one being checked) installed in the Model 7001/7002 mainframe. These conditions do not apply if the backplane jumpers are removed.

CAUTION

Contamination will degrade the performance of the matrix card. To avoid contamination, always grasp the card by the side edges. Do not touch the connectors, and do not touch the board surfaces or components. On plugs and receptacles, do not touch areas adjacent to the electrical contacts.

NOTE

Failure of any performance verification test may indicate the matrix card is contaminated. See paragraph 5.2 for information on cleaning the card.

5.3.1 Environmental conditions

All verification measurements should be made at an ambient temperature between 18° and 28°C, and at a relative humidity of less than 70%.

5.3.2 Recommended verification equipment

Table 5-1 summarizes the equipment necessary for performance verification, along with the application for each instrument. Note that the required connecting cables are not shown and are left to the discretion of the technician.

Be sure to use low-noise triax cable for electrometer connections.

Table 5-1
Recommended verification equipment

Description	Model	Specifications	Test
DMM	Keithley Model 2010	10Ω; 60ppm	Channel resistance
Electrometer	Keithley Model 6517	200pA; 1% 2GΩ, 0.225%	Offset current, Isolation resistance

Note: Required connecting cables not shown.

5.3.3 Matrix card connections

The recommended method for making instrument connections to the matrix card is by hard-wiring a 96-pin female DIN connector and then mating it to the connector on the Model 7019-C. Figure 5-1 shows connector terminal identification. The connector in the Model 7011-KIT-R connection kit (see Table 3-2) can be used for this purpose.

NOTE

After making solder connections to a connector, remove solder flux as explained in paragraph 5.2. Failure to clean the solder connections could result in degraded performance, preventing the card from passing verification tests.

Before pre-wiring any connector plugs, study the following test procedures to fully understand the connection requirements.

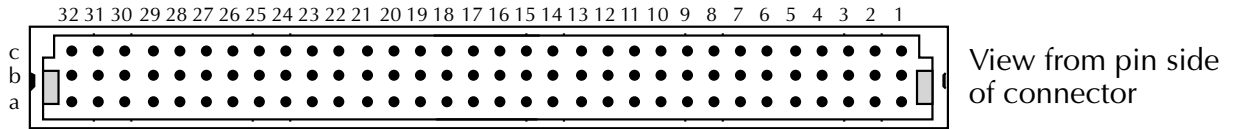

Matrix terminal	Connector designation 1a-32c	Schematic designation 1-96
FORCE+	2c	66
FORCE-	3c	67
GUARD	6c	70
SENSE+	4c	68
SENSE-	5c	69
GUARD SENSE	7c	71
A	9c	73
B	8c	72
IN1	11c	75
IN2	12c	76
IN3	13c	77
IN4	14c	78
IN5	15c	79
IN6	16c	80
IN7	17c	81
IN8	18c	82
IN9	19c	83
IN10	20c	84
IN11	21c	85
IN12	22c	86
IN13	23c	87
IN14	24c	88
IN15	25c	89
IN16	26c	90
Shield pins	9a, 9b	9, 41

Note: Short pins 1a to 1b on the mating connector (pins 1 and 33 on schematic) to allow the output relays on the connector card to close.

Figure 5-1
96-pin connector terminal identification

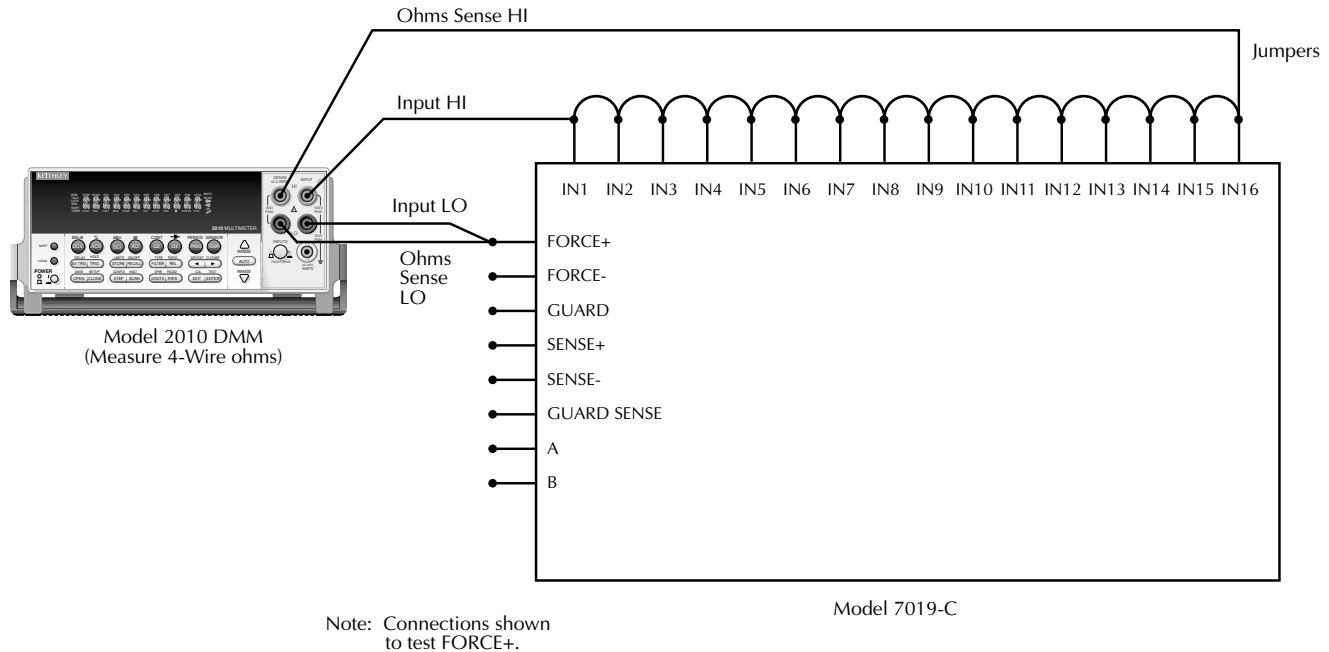

Figure 5-2
Connections for channel resistance tests

5.3.4 Channel resistance tests

Referring to Figure 5-2, perform the following steps to verify that every relay is closing properly and that the channel resistance is within specification.

1. Turn off the Model 7001/7002.
2. Install the Model 7019-C in slot 1 (CARD 1) of the Model 7001/7002.
3. As shown in Figure 5-2, connect the terminals of all matrix columns (IN1 through IN16) together to form one common terminal.
4. Set the Model 2010 to the 10Ω range, and connect four test leads to the INPUT and SENSE jacks.
5. Short the free ends of the four test leads together, and enable the Model 2010 REL mode. Leave REL enabled for the entire test.
6. Connect INPUT HI and SENSE HI of the Model 2010 to the common column terminals. Make physical connections at IN1 and IN16 as shown.
7. Connect the DMM INPUT LO and SENSE LO test leads to the FORCE+ row terminal as shown in Figure 5-2.
8. Turn on the Model 7001/7002.
9. Program the mainframe to close Channel 1!1 (Slot 1, Channel 1). Verify that the resistance of this channel is <math><1\Omega</math>.
10. Open Channel 1!1.
11. Repeat steps 9 and 10 for channels 2 through 6 (Channel 1!2 through Channel 1!6). In each instance, verify that the channel resistance is <math><1\Omega</math>.
12. Repeat steps 9 through 10 for each row connection and channel summarized in Table 5-2. For each test:
 - Connect the DMM INPUT LO and SENSE LO terminals to the appropriate Model 7019-C row.
 - Test each channel for that row listed in the table, being sure to close only one channel for each test.
 - Make sure each channel resistance reading is <math><1\Omega</math>.

Table 5-2
Channel resistance test summary

DMM row connection	Closed channels*	Mainframe channel programming**
FORCE+	1 - 6	1!1 - 1!6
FORCE-	7 - 12	1!7 - 1!12
GUARD	13 - 18	1!13 - 1!18
SENSE+	19 - 24	1!19 - 1!24
SENSE-	25 - 30	1!25 - 1!30
GUARD SENSE	31 - 36	1!31 - 1!36
A	37, 38	1!37, 1!38
B	39, 40	1!39, 1!40

* Close only one channel at a time. See procedure.
** Assumes Model 7019-C is installed in Slot 1.

5.3.5 Offset current tests

These tests check offset (leakage) current between row pairs. These tests are performed by measuring the leakage current with a Model 6517 Electrometer.

Referring to Figure 5-3, perform the following procedure to check offset current:

1. Turn off the Model 7001/7002.
2. Install the Model 7019-C in Slot 1 of the Model 7001/7002.

3. Connect the Model 6517 Electrometer INPUT HI terminal to the FORCE+ row of the matrix card as shown in Figure 5-3. Connect the electrometer INPUT LO terminal to FORCE- as shown.
4. Select the Model 6517 200pA range, enable zero check, and zero correct the instrument.
5. Turn on the Model 7001/7002.
6. Program the Model 7001/7002 to close channels 1!1 and 1!7.
7. Disable Model 6517 zero check, and verify that the current reading is <100pA. This measurement is the leakage current of the pathway.
8. Enable Model 6517 zero check, and open channels 1!1 and 1!7.
9. Repeat the basic procedure in steps 6 through 8 to check the rest of the pathway pair(s) (channels 1!2 through 1!6 of the FORCE+ row, and channels 1!7 through 1!12 of FORCE-).
10. Repeat the procedure in steps 6 through 9 for the remaining rows and channels, using Table 5-3 as guide. For each test:
 - Connect the electrometer INPUT HI and LO terminals to the indicated rows.
 - Close only one channel pair at a time (one channel for each row).
 - Verify that the offset current for each channel is <100pA.

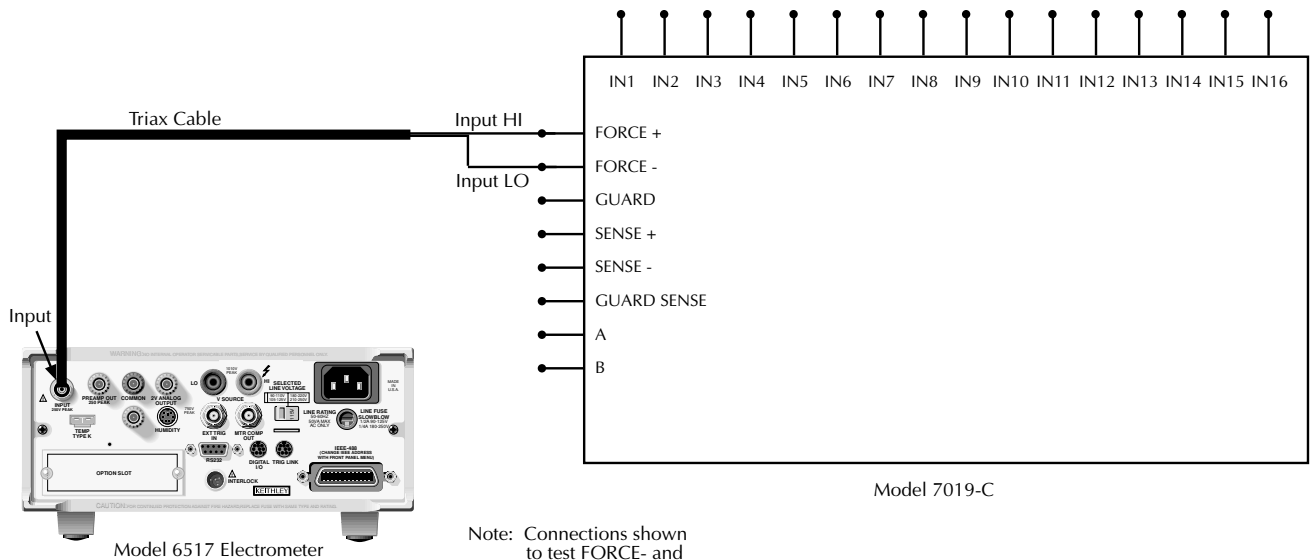

Note: Connections shown to test FORCE- and FORCE+ rows.

Figure 5-3
Connections for offset current tests

Table 5-3
Offset current test summary

Electrometer connections	Closed channels*	Mainframe channel programming**
FORCE+	1 - 6	1!1 - 1!6
FORCE-	7 - 12	1!7 - 1!12
GUARD	13 - 18	1!13 - 1!18
GUARD SENSE	31 - 36	1!31 - 1!36
SENSE+	19 - 24	1!19 - 1!24
SENSE-	25 - 30	1!25 - 1!30
A	37, 38	1!37, 1!38
B	39, 40	1!39, 1!40

* Close only one channel pair at a time. See procedure.
** Assumes Model 7019-C is installed in Slot 1.

5.3.6 Path isolation tests

These tests check the leakage resistance (isolation) between adjacent paths. A path is defined as the circuit from a row to a column that results from closing a particular crosspoint. The test is performed by using the ohms function of the Model 6517 Electrometer to measure the path isolation resistance.

1. Turn off the Model 7001/7002.
2. Install the Model 7019-C in slot 1 of the Model 7001/7002.

3. Connect the Model 6517 INPUT HI and voltage source HI terminals to the FORCE+ and FORCE- rows as shown in Figure 5-4. Make sure the voltage source is off. Also, make sure there are no other connections to the card. Select the Model 6517 ohms function and 2GΩ range. Make sure the internal voltage source connection mode is turned on.
4. Select the Model 6517 ohms function and 2GΩ range. Make sure the internal voltage source connection mode is turned on.
5. Turn on the Model 7001/7002, and program it to close Channels 1!1 (Channel 1) and 1!8 (Channel 8).
6. Set the Model 6517 Voltage Source to 200V and turn on the output.
7. After allowing the Model 6517 reading to settle, verify that the resistance reading is >1GΩ .
8. Repeat steps 5 through 8 for the remaining FORCE+ and FORCE- row channel pairs listed in Table 5-4.
9. Turn off the Model 6517 voltage source.
10. Repeat steps 5 through 9 for the remaining pathways listed in Table 5-4. For each test:
 - Connect the electrometer INPUT HI and voltage source HI terminals to the indicated Model 7019-C rows.
 - Close only the pair of channels being tested.
 - Make sure the Model 6517 voltage source is on.
 - Verify that the path isolation resistance in each case is >1GΩ .

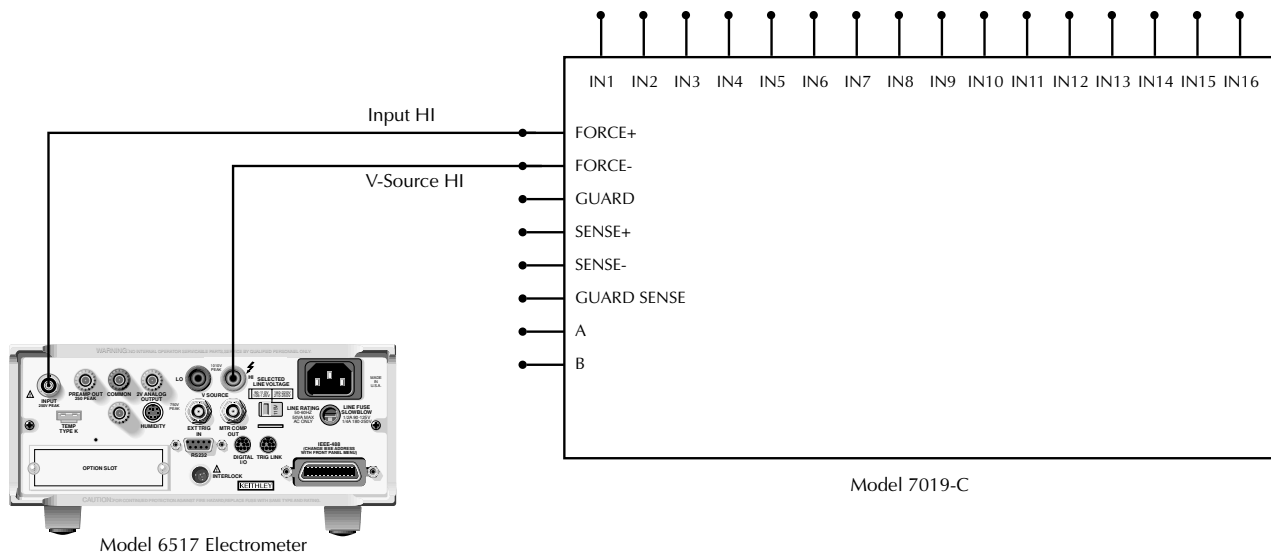

Figure 5-4
Connections for path isolation tests

Table 5-4
Path isolation test summary

Row connections	Closed channels*	Mainframe channel programming**	
FORCE+, FORCE-	1, 8	1!1, 1!8	
	2, 9	1!2, 1!9	
	3, 10	1!3, 1!10	
	4, 11	1!4, 1!11	
	5, 12	1!5, 1!12	
	FORCE-, GUARD	7, 14	1!7, 1!14
		8, 15	1!8, 1!15
		9, 16	1!9, 1!16
		10, 17	1!10, 1!17
	SENSE+, SENSE-	11, 18	1!11, 1!18
19, 26		1!19, 1!26	
20, 27		1!20, 1!27	
21, 28		1!21, 1!28	
22, 29		1!22, 1!29	
23, 30		1!23, 1!30	
SENSE-, GUARD SENSE	25, 32	1!25, 1!32	
	26, 33	1!26, 1!33	
	27, 34	1!27, 1!34	
	28, 35	1!28, 1!35	
	29, 36	1!29, 1!36	
A, B	37, 39	1!37, 1!39	
	38, 40	1!38, 1!40	

* Close both channels simultaneously for each test.
** Assumes Model 7019-C is installed in Slot 1.

5.3.7 Common-mode isolation tests

These tests check the leakage resistance (isolation) between each pathway and chassis ground using the ohms function of the Model 6517 Electrometer. The procedure is:

1. Turn off the Model 7001/7002.
2. Install the Model 7019-C in slot 1 of the Model 7001/7002.
3. Connect the Model 6517 voltage source HI terminal to the FORCE+ row, and connect the electrometer INPUT HI terminal to chassis ground of the mainframe, as shown in Figure 5-5. Make sure the voltage source is off. Also, make sure there are no other connections to the card.
4. Select the Model 6517 ohms function, and choose the 2GΩ range. Make sure the internal voltage source connection mode is enabled.
5. Turn on the Model 7001/7002.
6. Program the Model 7001/7002 to close Channel 1!1. Set the Model 6517 Voltage Source to 200V and turn on the output.
7. After settling, verify that the Model 6517 resistance reading is >1GΩ. This measurement is the common-mode isolation resistance of the pathway.
8. Turn off the Model 6517 voltage source, and open Channel 1!1.
9. Repeat the basic procedure in steps 6 through 8 to check the rest of the pathways (Channels 1!2 through 1!6) of the FORCE+ row.

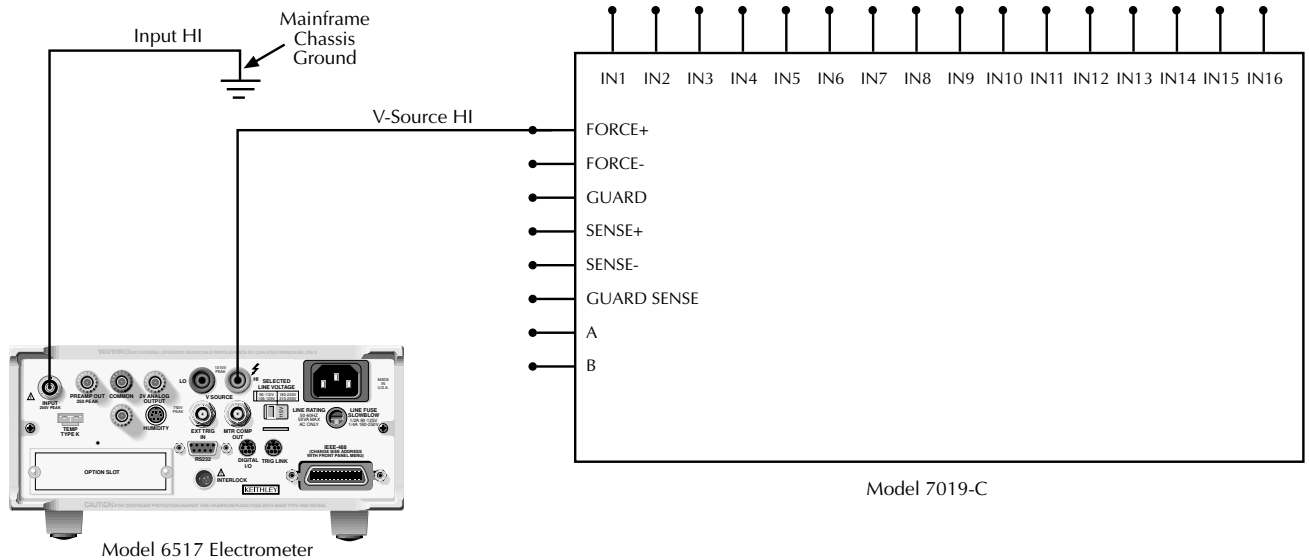

Figure 5-5
Connections for common-mode isolation tests

10. Repeat the procedure in steps 6 through 9 for the remaining rows, using Table 5-5 as guide. For each test:
 - Connect the electrometer voltage source HI terminal to the indicated row.
 - Close only one channel at a time.
 - Make sure the Model 6517 voltage source is on.
 - Verify that the isolation resistance is $>1G\Omega$.

Table 5-5
Common-mode isolation test summary

Electrometer connection	Closed channels*	Mainframe channel programming**
FORCE+	1 - 6	1!1 - 1!6
FORCE-	7 - 12	1!7 - 1!12
GUARD	13 - 18	1!13 - 1!18
SENSE+	19 - 24	1!19 - 1!24
SENSE-	25 - 30	1!25 - 1!30
GUARD SENSE	31 - 36	1!31 - 1!36
A	37, 38	1!37, 1!38
B	39, 40	1!39, 1!40

* Close only one channel at a time. See procedure.
 ** Assumes Model 7019-C is installed in Slot 1.

5.4 Special handling of static-sensitive devices

CMOS and other high-impedance devices are subject to possible static discharge damage because of the high-impedance levels involved. The following precautions pertain specifically to static-sensitive devices. However, since many devices in the Model 7019-C are static-sensitive, it is recommended that they are all treated as static-sensitive.

- Such devices should be transported and handled only in containers specially designed to prevent or dissipate static build-up. Typically, these devices will be received in anti-static containers made of plastic or foam. Keep these parts in their original containers until ready for installation.
- Remove the devices from their protective containers only at a properly grounded work station. Also, ground yourself with a suitable wrist strap while working with these devices.
- Handle the devices only by the body; do not touch the pins.
- Any printed circuit board into which the device is to be inserted must first be grounded to the bench or table.
- Use only anti-static type de-soldering tools and grounded-tip soldering irons.

5.5 Principles of operation

The following paragraphs discuss the basic operating principles for the Model 7019-C and can be used when troubleshooting the matrix card. The schematic drawing of the matrix card is located at the end of Section 6.

5.5.1 Block diagram

Figure 5-6 shows a simplified block diagram of the Model 7019-C. Key elements include the relay drivers and relays, as well as the ROM, which contain card ID and configuration information. These various elements are discussed in the following paragraphs.

5.5.2 Card identification ROM

Upon power-up, card identification information from each card is read serially by the mainframe. This ID data includes such information as card ID, hardware settling time, and relay configuration information. ID data is contained within EEPROM U106.

5.5.3 Relay control

Card relays are controlled by serial data transmitted via the relay DATA line. A total of five bytes for each card are shifted in serial fashion into latches located in the card relay driver ICs, U101 through U105. The serial data is clocked in by the CLK line. As data overflows one register, it is fed out the QS line of the register down the chain.

Once all five bytes have shifted into the card, the STR (strobe) line is set high to latch the relay information into the Q outputs of the relay drivers, and the appropriate relays are energized (assuming the driver outputs are enabled). Note that a relay driver output goes low to energize the corresponding relay.

5.5.4 Power-on safeguard

The power-on safeguard circuit keeps relays from inadvertently turning on when the mainframe power is turned on or off. The safeguard circuit controls the OE (output enable) terminals of the relay driver ICs (U101 through U105) and is located in the mainframe. See the Model 7001/7002 Instruction Manual for details.

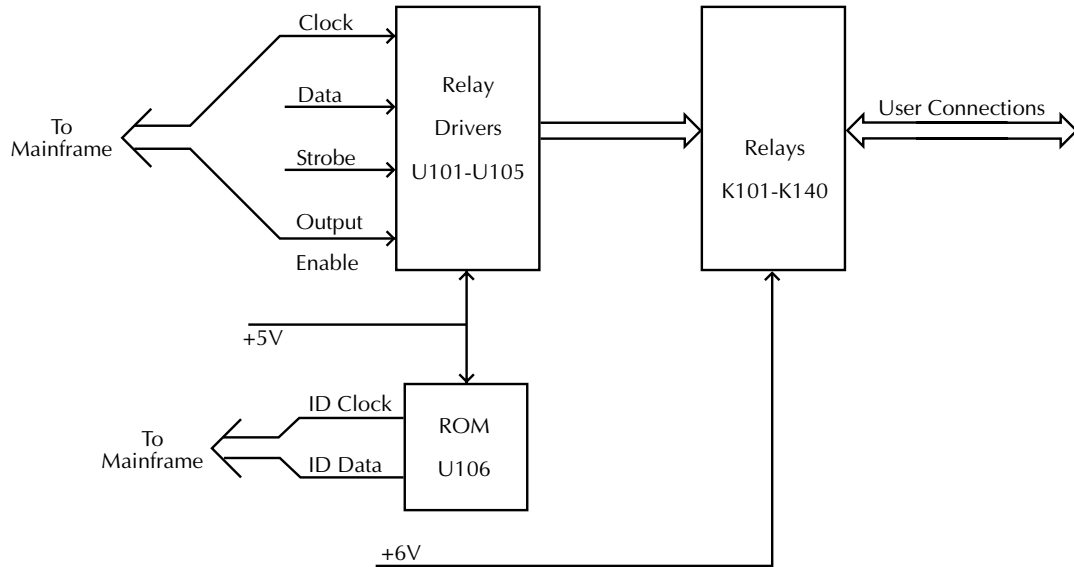

Figure 5-6
Block diagram

5.6 Troubleshooting

5.6.1 Troubleshooting equipment

Table 5-6 summarizes recommended equipment for troubleshooting the Model 7019-C.

Table 5-6
Recommended troubleshooting equipment

Description and model	Manufacturer	Application
Multimeter	Keithley 2000	Measure DC voltages
Oscilloscope	TEK 2243	View logic waveforms

5.6.2 Troubleshooting access

To gain access to the relay card top surface to measure voltages under actual operation conditions (Model 7001 only), perform the following steps:

1. Disconnect the connector card from the relay card.
2. Remove the Model 7001 cover.
3. Install the relay card in the CARD 1 slot location.
4. Turn on Model 7001 power to measure voltages (see the following paragraph).

5.6.3 Troubleshooting procedure

Table 5-7 summarizes the troubleshooting procedure for the Model 7019-C.

WARNING

Lethal voltages are present within the Model 7001 mainframe. Some of the procedures may expose you to hazardous voltages. Observe standard safety precautions for dealing with live circuits. Failure to do so could result in personal injury or death.

CAUTION

Observe the following precautions when troubleshooting or repairing the switch card:

- To avoid contamination, which could degrade card performance, only handle the card by the handle and side edges. Do not touch edge connectors, board surfaces, or components on the card. Also, do not touch areas adjacent to electrical contacts on connectors.

- Use care when removing relays from the PC board to avoid pulling traces away from the circuit board. Before attempting to remove a relay, use an appropriate de-soldering tool, such as a solder sucker, to completely clear each mounting hole of solder. Each relay pin must be free to move in its mounting hole before removal. Also, make sure no burrs are present on the ends of the relay pins.

*Table 5-7
Troubleshooting procedure*

Step	Item/component	Required condition	Comments
1	Digital ground (P2001, pins 3 and 4)		All voltages referenced to digital ground.
2	U101-U105, pin 10	+6V DC	Relay voltage.
3	U106, pin 8	+5V DC	Logic voltage.
4	U106, pin 6	ID ROM clock pulses	During power-up only.
5	U106, pin 5	ID ROM data pulses	During power-up only.
6	U101-U105, pin 7	STR pulse	End of relay update sequence.
7	U101-U105, pin 2	CLK pulses	During relay update sequence only.
8	U101-U105, pin 3	DATA pulses	During relay update sequence only.
9	U101-U105, pins 11-18	Low with relay energized; high with relay de-energized.	Relay driver outputs.

6

Replaceable Parts

6.1 Introduction

This section contains replacement parts information, schematic diagrams, and component layout drawings for the Model 7019-C.

6.2 Parts lists

Parts lists for the relay and connector boards are included in tables integrated with schematic diagrams and component layout drawings for the boards. Parts are listed alphabetically in order of circuit designation.

6.3 Ordering information

To place an order or to obtain information concerning replacement parts, contact your Keithley representative or the factory (see inside front cover for addresses). When ordering parts, be sure to include the following information:

- Card model number (7019-C)
- Card serial number
- Part description
- Circuit description, if applicable
- Keithley part number

6.4 Factory service

If the card is to be returned to Keithley Instruments for repair, perform the following:

- Call the Repair Department at 1-800-552-1115 for a Return Material Authorization (RMA) number.
- Complete the service form at the back of this manual and include it with the card.
- Carefully pack the card in the original packing carton.
- Write ATTENTION REPAIR DEPT and the RMA number on the shipping label.

NOTE

It is not necessary to return the switching mainframe with the card.

6.5 Component layouts and schematic diagrams

Component layout drawings and schematic diagrams for the relay and connector boards are included on the following pages integrated with the parts lists.

Table 6-1
Relay board parts list

Circuit designation	Description	Keithley part no.
	SHIELD	7011-305C
C101-106	CAP, .1UF,20%,50V,CERAMIC	C-365-.1
C107-109	CAP,150PF,10%,1000V,CERAMIC	C-64-150P
C110, 111	CAP, 10UF,-20+100%,25V,ALUM ELEC	C-314-10
J1002,1003	CONN, 48-PIN, 3-ROWS	CS-736-2
K101-140	RELAY (SPST),COTO 9000-0149	RL-131
P2001	CONNECTOR, 32-PIN, 2-ROWS	CS-775-1
R101	RES,10K,5%,1/4W,COMPOSITION OR FILM	R-76-10K
U101-105	IC, 8-BIT SERIAL-IN LATCH DRIVER,5841A	IC-536
U106	PROGRAMMED EPROM	7019-800-*
W101-108	JUMPER	J-15

* Order same firmware revision as present part. (For example, A01.)

Table 6-2
Connector board parts list

Circuit Designation	Description	Keithley part no.
	SHIELD	7011-311A
C202-205	CAP, 10UF, 20%, 50V, ALUM ELEC	C-489-10
CR201	DIODE,SILICON,IN4148	RF-28
J1004	CONNECTOR, 96-PIN	CS-514
K201-205	RELAY, MINI SIGNAL	RL-163
P1002,1003	CONNECTOR, 48-PIN	CS-748-3
R202-205	RES,100,5%,1/4W,COMPOSITION OR FILM	R-76-100

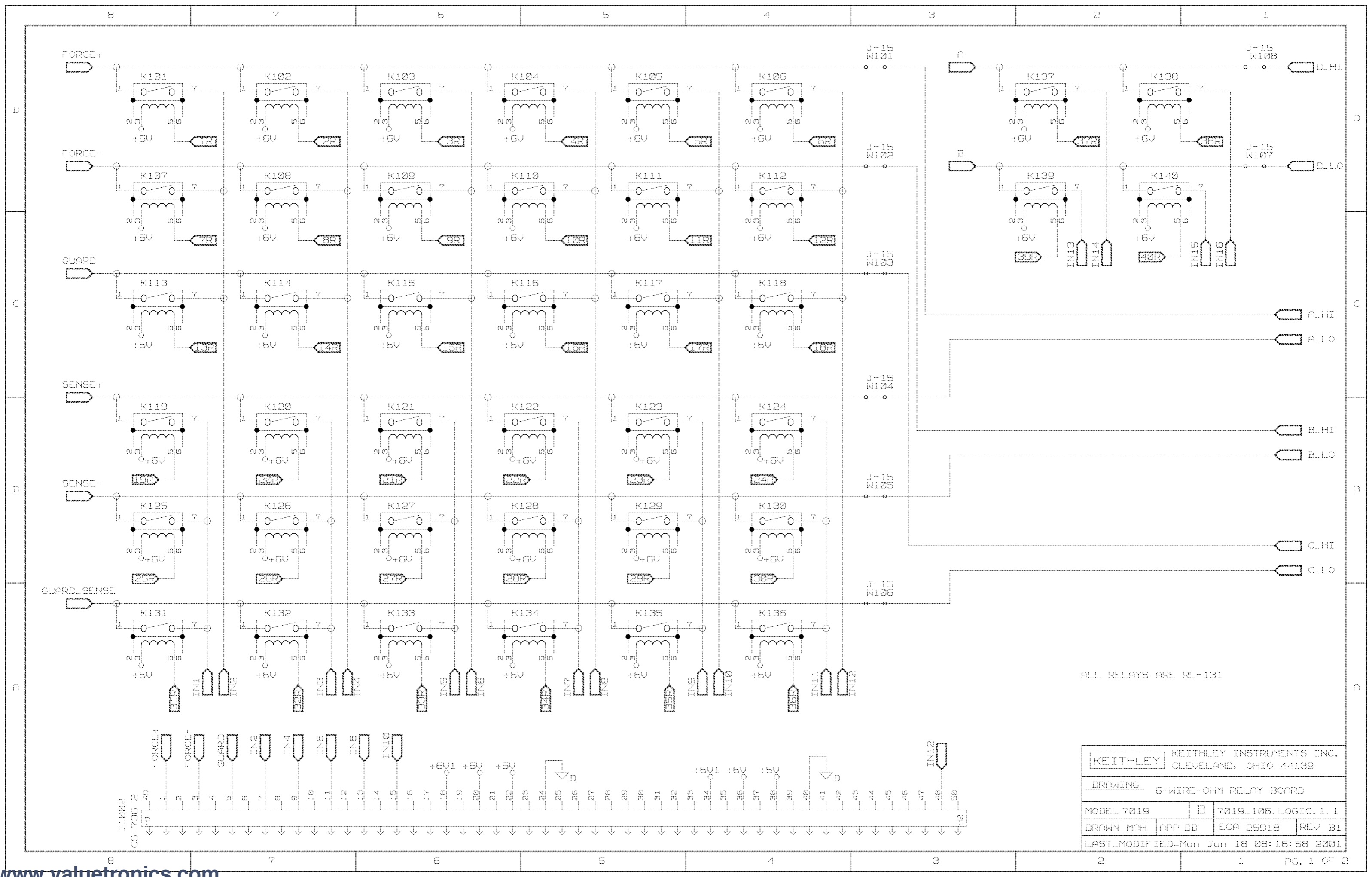

ALL RELAYS ARE RL-131

KEITHLEY		KEITHLEY INSTRUMENTS INC. CLEVELAND, OHIO 44139	
DRAWING 6-WIRE-OHM RELAY BOARD			
MODEL 7019	B	7019.106.LOGIC.1.1	
DRAWN MAH	APP DD	ECA 25918	REV B1
LAST_MODIFIED=Mon Jun 18 08:16:58 2001			

LTR.	ECA NO.	REVISION	ENG.	DATE
A		PRELIMINARY		
B	18889	RELEASED	S.Z.	6/26/96
B1	25918	CHANGED U106 TO TC17-100B	ELS	6/18/01

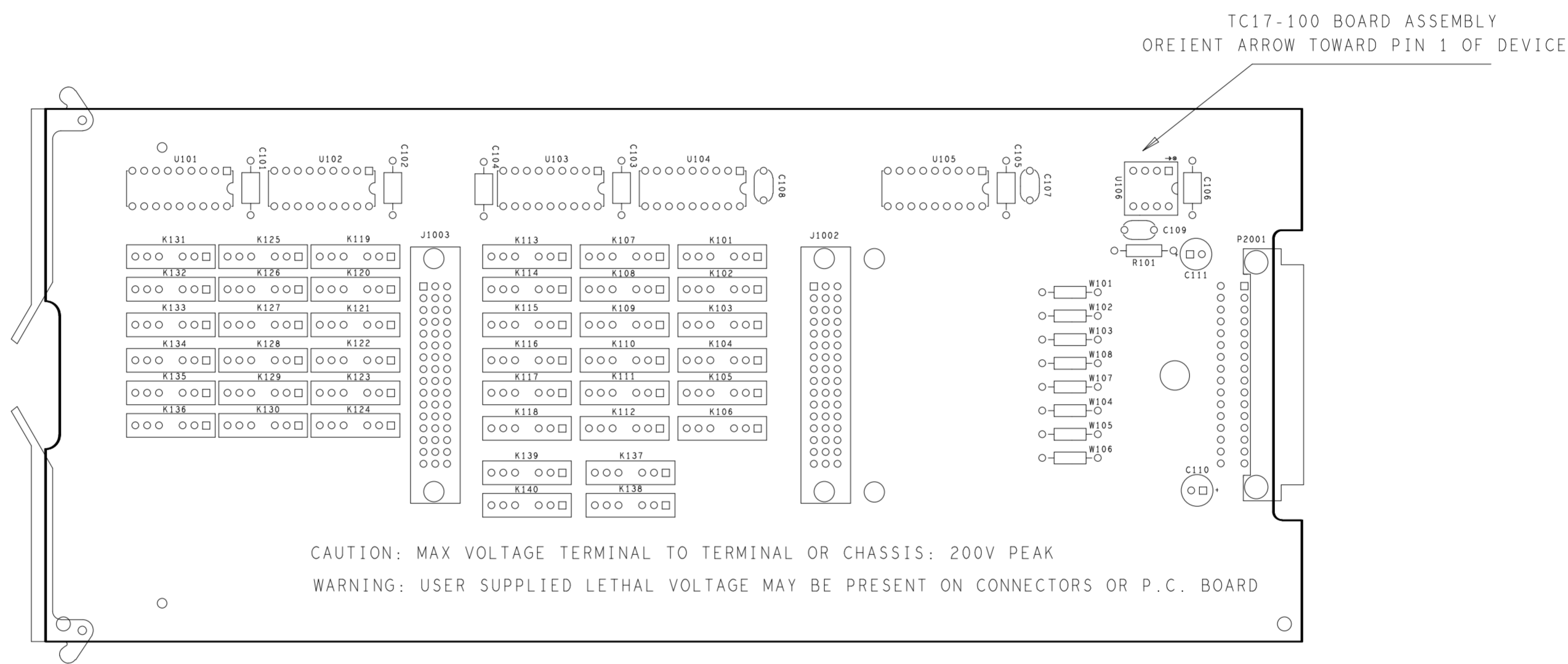

FOR COMPONENT INFORMATION SEE PRODUCT STRUCTURE

MODEL	NEXT ASSEMBLY	QTY.
USED ON		

 KEITHLEY INSTRUMENTS INC. CLEVELAND, OHIO 44139	DIM ARE IN IN. UNLESS OTHERWISE NOTED	DATE 1/8/96	SCALE 1:1	TITLE COMPONENT LAYOUT, 6-WIRE-OHM RELAY BOARD
	DIM. TOL. UNLESS OTHERWISE SPECIFIED	DRN MAH	APPR.	
	XX=+.01 ANG.=+1 XXX=+.005 FRAC.=+1/64	DO NOT SCALE THIS DRAWING		

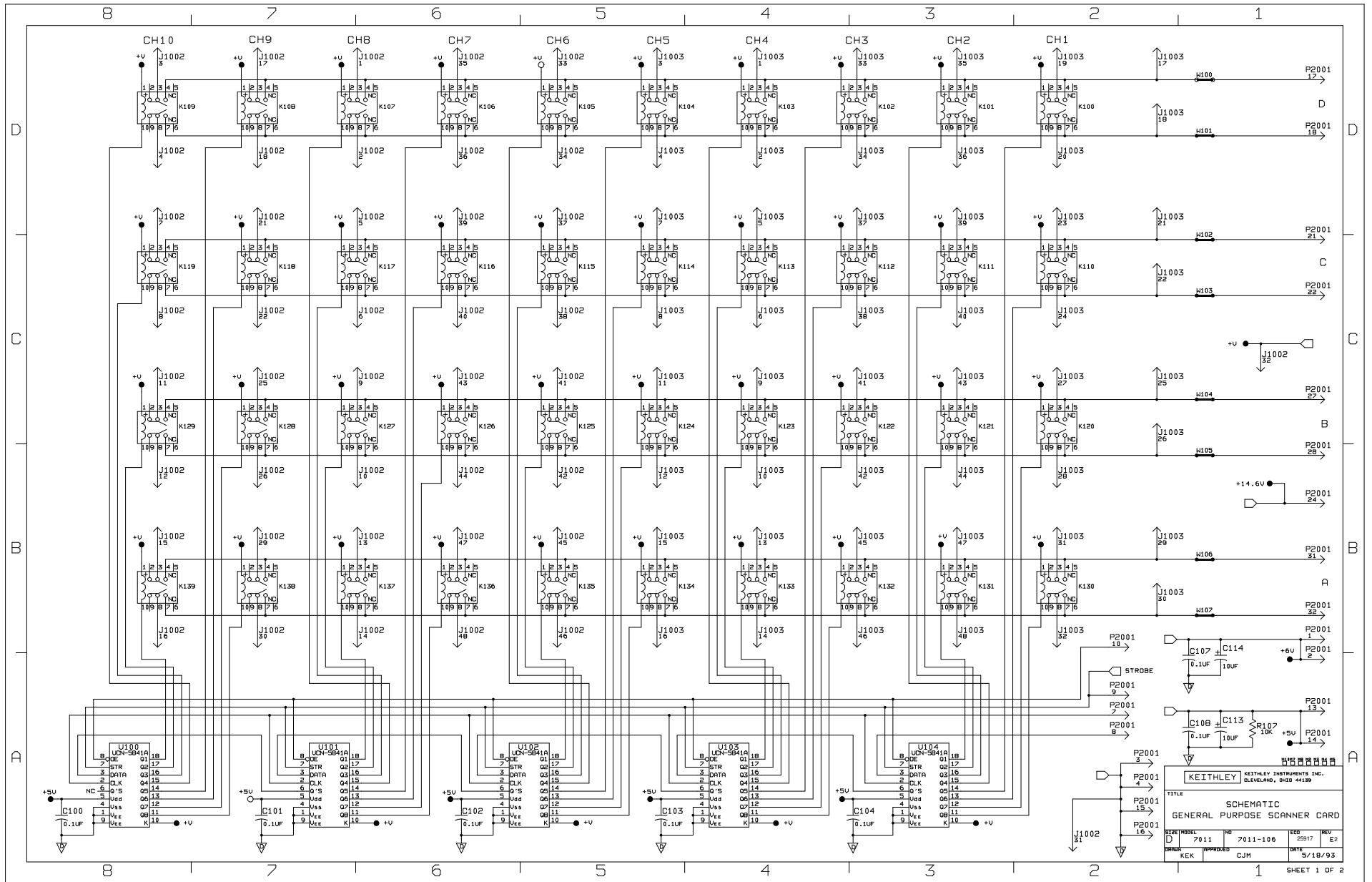

KEITHLEY KEITHLEY INSTRUMENTS INC.
CLEVELAND, OHIO 44139

TITLE
SCHEMATIC
GENERAL PURPOSE SCANNER CARD

SIZE	MODEL	NO	REV
D	7011	7011-106	25917 E2
ORIGIN	APPROVED	DATE	
KEK	CJM	5/18/93	

SHEET 1 OF 2

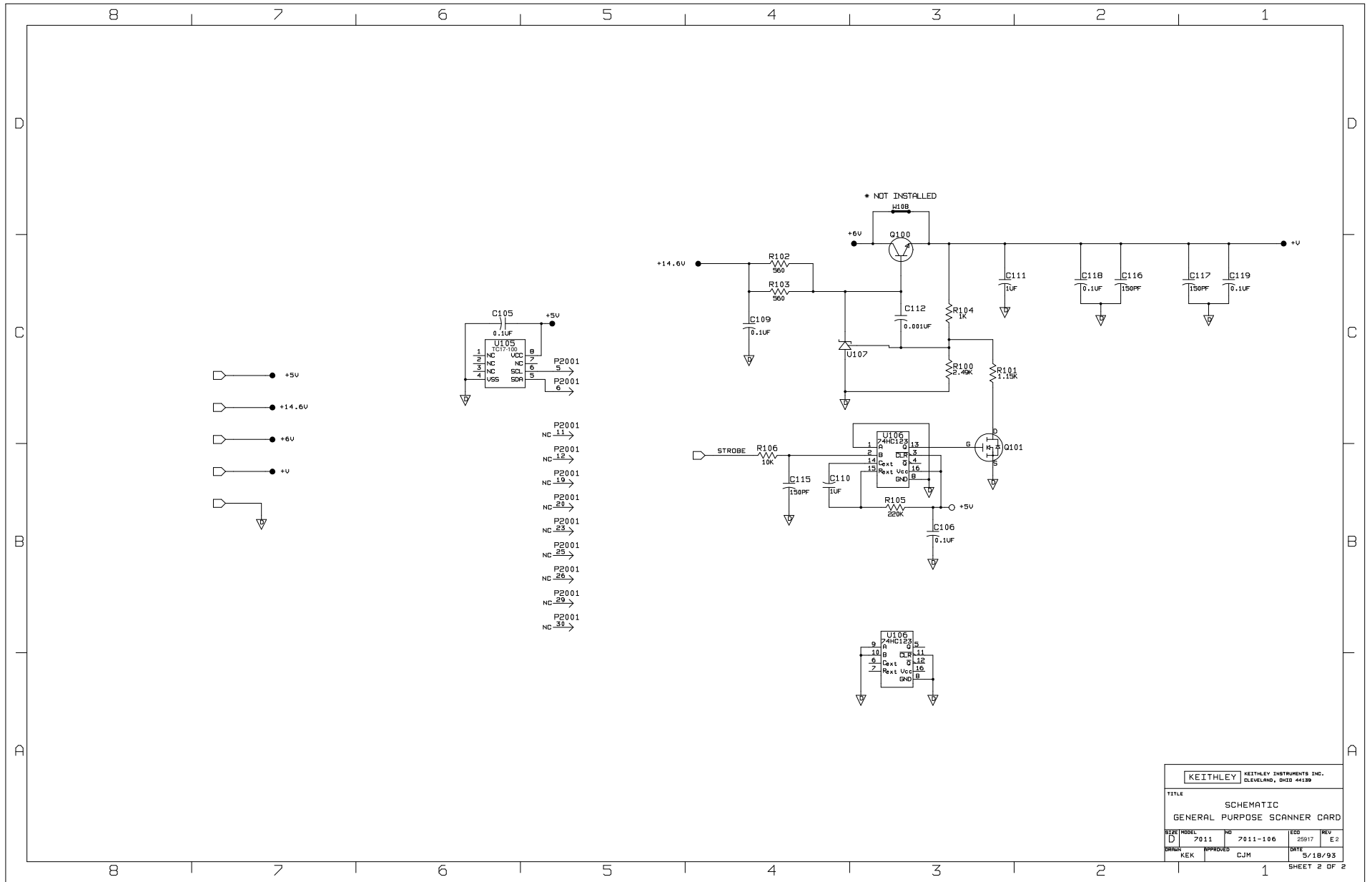

KEITHLEY		KEITHLEY INSTRUMENTS INC.	
		CLEVELAND, OHIO 44139	
TITLE			
SCHEMATIC			
GENERAL PURPOSE SCANNER CARD			
SIZE	MODEL	NO	REV
D	7011	7011-106	25917 E2
DRGR	APPROVED	DATE	
KEK	CJM	5/18/93	

001-1102.ON

LTR.	ECO NO.	REVISION	ENG.	DATE
B		PRELIMINARY		
C	910920	RELEASED	MS	9-20-91
D	15129	DELETED 2-56x3/8PPH(2 REQ'D)	SZ	8-5-92
D1	15453	ADDED MC-612, CHART FOR 7014, AND NOTE TO INSTALL W108 TO 7014 ONLY	SZ	9-1-92
D2	15565	RELOCATED MC-285 ON MODEL 7014	AS	11-30-92
E	15452	CHG'D ARTWORK FROM REV D TO E.		5-20-93
E2	25917	CHG'D U106 FROM TC737 TO TC17-100. DELETED R5,72.	KK	6/18/01

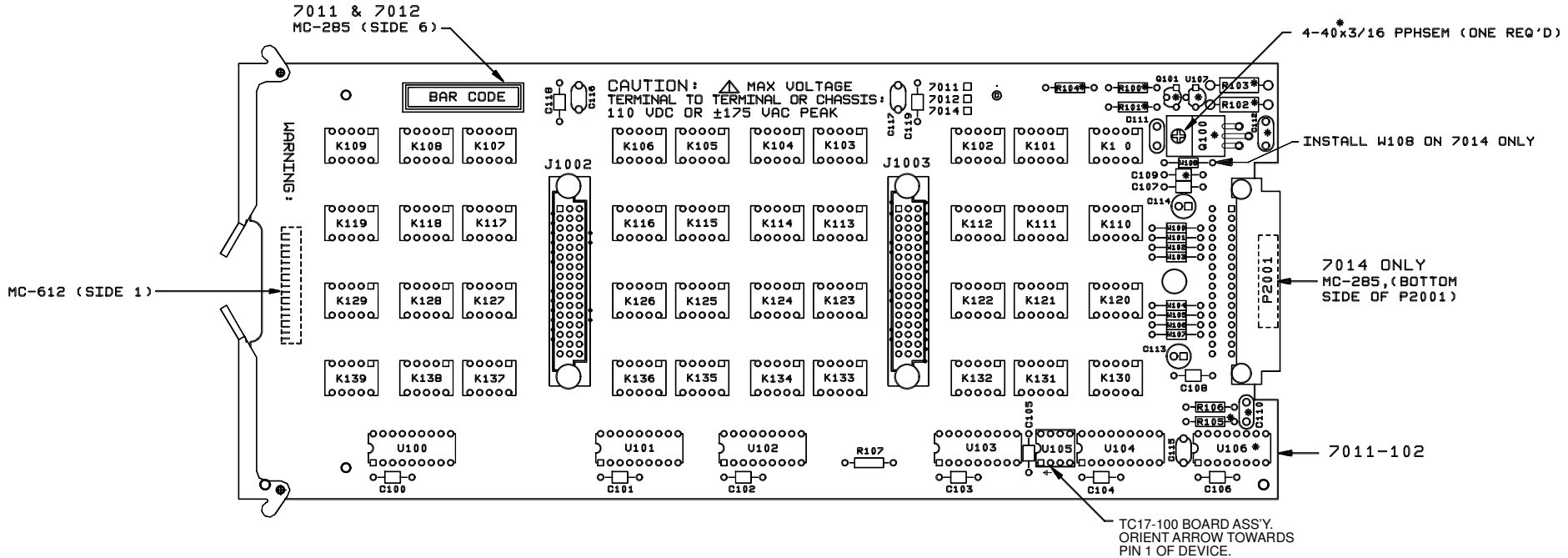

* FOR 7014 BUILD, DO NOT INSTALL THE FOLLOWING PARTS

R100	Q100	U106	C109
R101	Q101	U107	C110
R102			C112
R103			
R104		4-40X3/16PPHSEM	
R105			

NOTE: FOR COMPONENT INFORMATION, REFER TO PRODUCT STRUCTURE FOR 7011, 7012 AND 7014

MODEL	NEXT ASSEMBLY	QTY.
7014	7011-101	1
7012	7011-101	1
7011	7011-101	1

USED ON

DO NOT SCALE THIS DRAWING		DIMENSIONAL TOLERANCES UNLESS OTHERWISE SPECIFIED		DATE 8/12/91	SCALE 5:4	TITLE	COMPONENT LAYOUT SCANNER BOARD
KEITHLEY KEITHLEY INSTRUMENTS INC. CLEVELAND, OHIO 44139		XX=±.015	ANG.=±1°	DRN. KEK	ENG. APPR.	NO.	
		XXX=±.005	FRAC.=±1/64	MATERIAL		C	7011-100
		SURFACE MAX. 3		FINISH			

LTR.	ECA NO.	REVISION	ENG.	DATE
A		PRELIMINARY		
B				

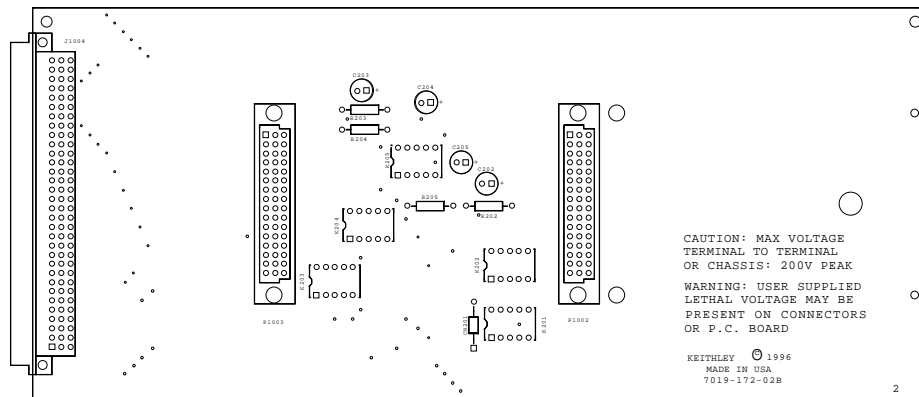

NOTE: FOR COMPONENT INFORMATION, PLEASE REFER TO PRODUCT STRUCTURE.

MODEL	NEXT ASSEMBLY	QTY.
USED ON		

KEITHLEY KEITHLEY INSTRUMENTS INC. CLEVELAND, OHIO 44139	DIM ARE IN IN. UNLESS OTHERWISE NOTED	DATE 1/17/96	SCALE 1:1	TITLE COMPONENT LAYOUT
	DIM. TOL. UNLESS OTHERWISE SPECIFIED	DRN KEK	APPR.	6-WIRE-OHM CONNECTOR BOARD
XX=+.01 XXX=+.005	ANG.=+1 FRAC.=+1/64	DO NOT SCALE THIS DRAWING	C	NO. 7019-170

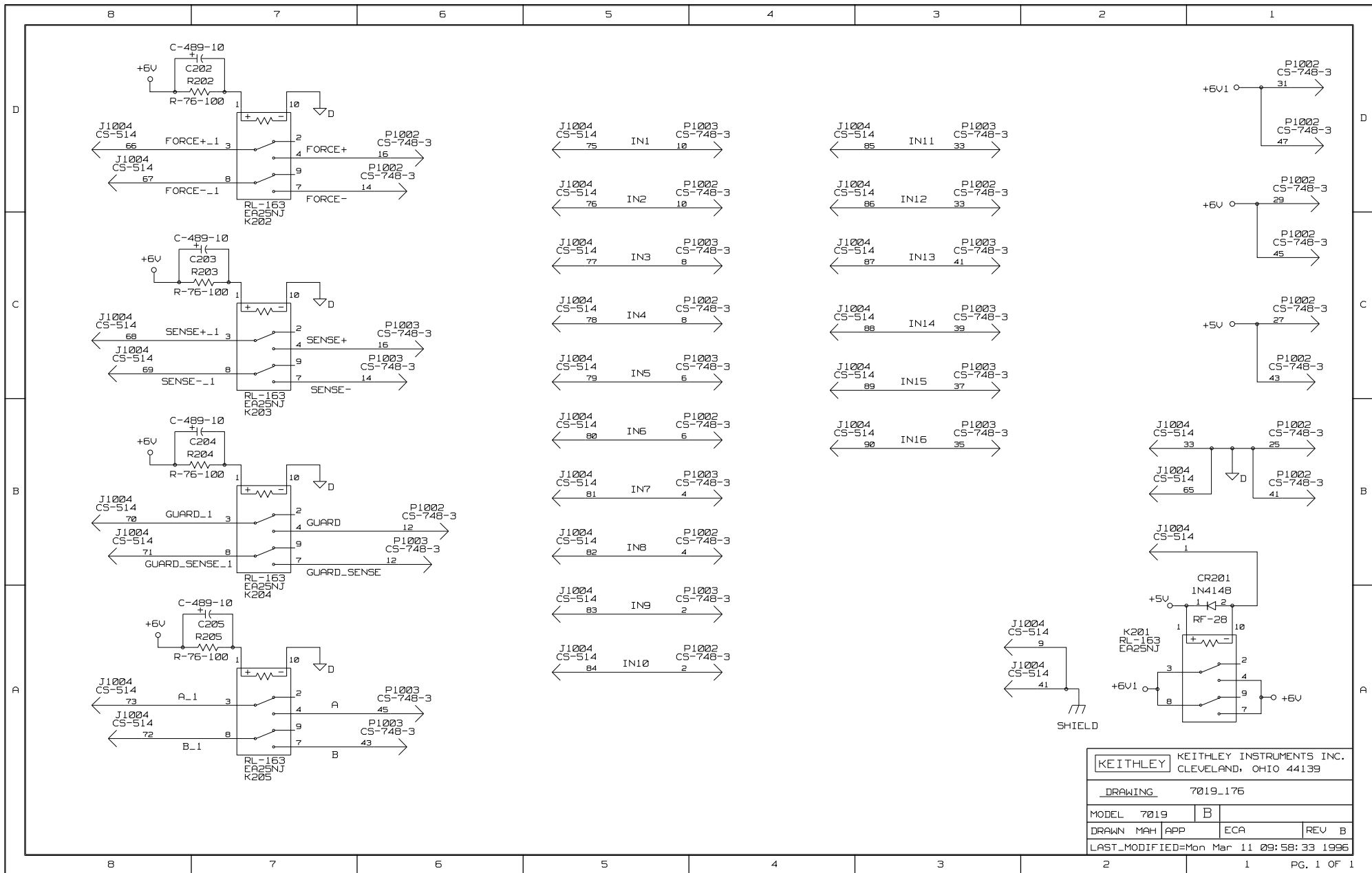

KEITHLEY		KEITHLEY INSTRUMENTS INC.	
		CLEVELAND, OHIO 44139	
DRAWING		7019.176	
MODEL	7019	B	
DRAWN	MAH	APP	ECA
LAST_MODIFIED=Mon Mar 11 09:58:33 1996		REV	B

A

Automatic crosspoint sequencing 4-3

B

Backplane jumpers 2-1
Backplane row jumpers 3-1
Basic matrix configuration 2-1
Basic six-wire ohms test procedure 4-7
Basic test procedure 4-9
Block diagram 5-8

C

Card connections and installation 3-1
Card identification ROM 5-8
Channel assignments 4-2
Channel resistance tests 5-4
Common-mode isolation tests 5-7
Component layouts and schematic diagrams 6-1
Connections 3-1
Connector insulation and cleaning 3-6
Connector terminal identification 3-2

E

Environmental conditions 5-2

F

Factory service 6-1
Features 1-1
Front panel control 4-3

G

General information 1-1
Ground loops 4-4

H

Handling and cleaning precautions 5-1
Handling precautions 1-2, 3-1

I

IEEE-488 bus operation 4-3
Inspection for damage 1-2
Instruction manual 1-2
Isolated switching systems 2-3

K

Keeping connectors clean 4-5

M

Magnetic fields 4-4
Mainframe analog backplane 2-1
Mainframe control of matrix card 4-1
Manual addenda 1-1
Matrix card connections 5-2
Matrix card installation 3-8
Matrix card removal 3-9
Matrix expansion 2-3
Matrix expansion (dual 3×12 matrix) 2-3
Matrix switching basics 2-1
Maximizing relay life 4-1
Maximum signal levels 4-1
Measurement considerations 4-3
Model 7019-C installation and removal 3-8
Multi-card system 3-7

O

Offset current tests 5-5
Operation 4-1
Optional accessories 1-2
Ordering information 6-1

P

Parts list 6-1
Path isolation 4-4
Path isolation tests 5-6
Performance verification 5-1
Power-on safeguard 5-8
Principles of operation 5-8

R

Radio frequency interference 4-4
Recommended verification equipment 5-2
Relay control 5-8
Repacking for shipment 1-2
Replaceable parts 6-1
Row connections to backplane 2-2

S

Safety and signal considerations 4-1
Safety considerations 4-1
Safety symbols and terms 1-2
Servicing 5-1
Shipping contents 1-2
Single-card system 3-6
Six-wire ohms matrix switching 2-3
Six-wire ohms measurement technique 4-6
Six-wire ohms resistance testing applications 4-5
Six-wire ohms test switching connections 4-7
Special handling of static-sensitive devices 5-8
Specifications 1-2
Split Kelvin measurement technique 4-8
Split Kelvin test connections 4-9

T

Troubleshooting 5-9
Troubleshooting access 5-9
Troubleshooting equipment 5-9
Troubleshooting procedure 5-9
Types of resistor networks 4-5
Typical connection schemes 3-6
Typical connection techniques 3-4
Typical matrix switching schemes 2-3
Typical resistor network tests 4-6

U

Unpacking and inspection 1-2
Utility pathway switching 2-3

W

Warranty information 1-1



Service Form

Model No. _____ Serial No. _____ Date _____

Name and Telephone No. _____

Company _____

List all control settings, describe problem and check boxes that apply to problem. _____

- | | | |
|--|--|--|
| <input type="checkbox"/> Intermittent | <input type="checkbox"/> Analog output follows display | <input type="checkbox"/> Particular range or function bad; specify _____ |
| <input type="checkbox"/> IEEE failure | <input type="checkbox"/> Obvious problem on power-up | <input type="checkbox"/> Batteries and fuses are OK |
| <input type="checkbox"/> Front panel operational | <input type="checkbox"/> All ranges or functions are bad | <input type="checkbox"/> Checked all cables |

Display or output (check one)

- | | |
|-----------------------------------|--|
| <input type="checkbox"/> Drifts | <input type="checkbox"/> Unable to zero |
| <input type="checkbox"/> Unstable | <input type="checkbox"/> Will not read applied input |
| <input type="checkbox"/> Overload | |

- | | |
|---|--|
| <input type="checkbox"/> Calibration only | <input type="checkbox"/> Certificate of calibration required |
| <input type="checkbox"/> Data required | |

(attach any additional sheets as necessary)

Show a block diagram of your measurement system including all instruments connected (whether power is turned on or not). Also, describe signal source.

Where is the measurement being performed? (factory, controlled laboratory, out-of-doors, etc.)

What power line voltage is used? _____ Ambient temperature? _____ °F

Relative humidity? _____ Other? _____

Any additional information. (If special modifications have been made by the user, please describe.)

Be sure to include your name and phone number on this service form.

Specifications are subject to change without notice.

All Keithley trademarks and trade names are the property of Keithley Instruments, Inc. All other trademarks and trade names are the property of their respective companies.

KEITHLEY

Keithley Instruments, Inc.

BELGIUM: Keithley Instruments B.V.
CHINA: Keithley Instruments China
FRANCE: Keithley Instruments Sarl
GERMANY: Keithley Instruments GmbH
GREAT BRITAIN: Keithley Instruments Ltd.
INDIA: Keithley Instruments GmbH
ITALY: Keithley Instruments s.r.l.
KOREA: Keithley Instruments Korea
NETHERLANDS: Keithley Instruments B.V.
SWITZERLAND: Keithley Instruments SA
TAIWAN: Keithley Instruments Taiwan

28775 Aurora Road • Cleveland, Ohio 44139 • 440-248-0400 • Fax: 440-248-6168
1-888-KEITHLEY (534-8453) www.keithley.com

Bergensesteenweg 709 • B-1600 Sint-Pieters-Leeuw • 02/363 00 40 • Fax: 02/363 00 64
Yuan Chen Xin Building, Room 705 • 12 Yumin Road, Dewai, Madian • Beijing 100029 • 8610-6202-2886 • Fax: 8610-6202-2892
3, allée des Garays • 91127 Palaiseau Cédex • 01 64 53 20 20 • Fax: 01 60 11 77 26
Landsberger Strasse 65 • D-82110 Germering • 089/84 93 07-40 • Fax: 089/84 93 07-34
The Minster • 58 Portman Road • Reading, Berkshire RG30 1EA • 0118-9 57 56 66 • Fax: 0118-9 59 64 69
Flat 2B, WILLOCRISSA • 14, Rest House Crescent • Bangalore 560 001 • 91-80-509-1320/21 • Fax: 91-80-509-1322
Viale San Gimignano, 38 • 20146 Milano • 02-48 39 16 01 • Fax: 02-48 30 22 74
2FL., URI Building • 2-14 Yangjae-Dong • Seocho-Gu, Seoul 137-130 • 82-2-574-7778 • Fax: 82-2-574-7838
Postbus 559 • NL-4200 AN Gorinchem • 0183-635333 • Fax: 0183-630821
Kriesbachstrasse 4 • 8600 Dübendorf • 01-821 94 44 • Fax: 01-820 30 81
1FL., 85 Po Ai Street • Hsinchu, Taiwan, R.O.C. • 886-3-572-9077 • Fax: 886-3-572-9031