

KEITHLEY

Models 2510 and 2510-AT

TEC SourceMeter[®]

Service Manual

WARRANTY

Keithley Instruments, Inc. warrants this product to be free from defects in material and workmanship for a period of 1 year from date of shipment.

Keithley Instruments, Inc. warrants the following items for 90 days from the date of shipment: probes, cables, rechargeable batteries, diskettes, and documentation.

During the warranty period, we will, at our option, either repair or replace any product that proves to be defective.

To exercise this warranty, write or call your local Keithley representative, or contact Keithley headquarters in Cleveland, Ohio. You will be given prompt assistance and return instructions. Send the product, transportation prepaid, to the indicated service facility. Repairs will be made and the product returned, transportation prepaid. Repaired or replaced products are warranted for the balance of the original warranty period, or at least 90 days.

LIMITATION OF WARRANTY

This warranty does not apply to defects resulting from product modification without Keithley's express written consent, or misuse of any product or part. This warranty also does not apply to fuses, software, non-rechargeable batteries, damage from battery leakage, or problems arising from normal wear or failure to follow instructions.

THIS WARRANTY IS IN LIEU OF ALL OTHER WARRANTIES, EXPRESSED OR IMPLIED, INCLUDING ANY IMPLIED WARRANTY OF MERCHANTABILITY OR FITNESS FOR A PARTICULAR USE. THE REMEDIES PROVIDED HEREIN ARE BUYER'S SOLE AND EXCLUSIVE REMEDIES.

NEITHER KEITHLEY INSTRUMENTS, INC. NOR ANY OF ITS EMPLOYEES SHALL BE LIABLE FOR ANY DIRECT, INDIRECT, SPECIAL, INCIDENTAL OR CONSEQUENTIAL DAMAGES ARISING OUT OF THE USE OF ITS INSTRUMENTS AND SOFTWARE EVEN IF KEITHLEY INSTRUMENTS, INC., HAS BEEN ADVISED IN ADVANCE OF THE POSSIBILITY OF SUCH DAMAGES. SUCH EXCLUDED DAMAGES SHALL INCLUDE, BUT ARE NOT LIMITED TO: COSTS OF REMOVAL AND INSTALLATION, LOSSES SUSTAINED AS THE RESULT OF INJURY TO ANY PERSON, OR DAMAGE TO PROPERTY.

KEITHLEY

Keithley Instruments, Inc.

28775 Aurora Road • Cleveland, Ohio 44139 • 440-248-0400 • Fax: 440-248-6168
1-888-KEITHLEY (534-8453) • www.keithley.com

Sales Offices:

BELGIUM:	Bergensesteenweg 709 • B-1600 Sint-Pieters-Leeuw • 02-363 00 40 • Fax: 02/363 00 64
CHINA:	Yuan Chen Xin Building, Room 705 • 12 Yumin Road, Dewai, Madian • Beijing 100029 • 8610-6202-2886 • Fax: 8610-6202-2892
FINLAND:	Touhokatu 2 • 02100 Espoo • Phone: 09-54 75 08 10 • Fax: 09-25 10 51 00
FRANCE:	3, allée des Garays • 91127 Palaiseau Cédex • 01-64 53 20 20 • Fax: 01-60 11 77 26
GERMANY:	Landsberger Strasse 65 • 82110 Germering • 089/84 93 07-40 • Fax: 089/84 93 07-34
GREAT BRITAIN:	Unit 2 Commerce Park, Brunel Road • Theale • Berkshire RG7 4AB • 0118 929 7500 • Fax: 0118 929 7519
INDIA:	Flat 2B, Willocrissa • 14, Rest House Crescent • Bangalore 560 001 • 91-80-509-1320/21 • Fax: 91-80-509-1322
ITALY:	Viale San Gimignano, 38 • 20146 Milano • 02-48 39 16 01 • Fax: 02-48 30 22 74
JAPAN:	New Pier Takeshiba North Tower 13F • 11-1, Kaigan 1-chome • Minato-ku, Tokyo 105-0022 • 81-3-5733-7555 • Fax: 81-3-5733-7556
KOREA:	FL., URI Building • 2-14 Yangjae-Dong • Seocho-Gu, Seoul 137-130 • 82-2-574-7778 • Fax: 82-2-574-7838
NETHERLANDS:	Postbus 559 • 4200 AN Gorinchem • 0183-635333 • Fax: 0183-630821
SWEDEN:	c/o Regus Business Centre • Frosundaviks Allé 15, 4tr • 169 70 Solna • 08-509 04 679 • Fax: 08-655 26 10
SWITZERLAND:	Kriesbachstrasse 4 • 8600 Dübendorf • 01-821 94 44 • Fax: 01-820 30 81
TAIWAN:	1FL., 85 Po Ai Street • Hsinchu, Taiwan, R.O.C. • 886-3-572-9077 • Fax: 886-3-572-9031

www.valuetronics.com

Models 2510 and 2510-AT TEC SourceMeter® Service Manual

All references in this manual to the Model 2510 also apply to the Model 2510-AT unless otherwise specified.

Manual Print History

The print history shown below lists the printing dates of all Revisions and Addenda created for this manual. The Revision Level letter increases alphabetically as the manual undergoes subsequent updates. Addenda, which are released between Revisions, contain important change information that the user should incorporate immediately into the manual. Addenda are numbered sequentially. When a new Revision is created, all Addenda associated with the previous Revision of the manual are incorporated into the new Revision of the manual. Each new Revision includes a revised copy of this print history page.

Revision A (Document Number 2510-902-01)	April 2000
Revision B (Document Number 2510-902-01)	June 2000
Revision C (Document Number 2510-902-01)	December 2000
Revision D (Document Number 2510-902-01)	February 2002

The following safety precautions should be observed before using this product and any associated instrumentation. Although some instruments and accessories would normally be used with non-hazardous voltages, there are situations where hazardous conditions may be present.

This product is intended for use by qualified personnel who recognize shock hazards and are familiar with the safety precautions required to avoid possible injury. Read and follow all installation, operation, and maintenance information carefully before using the product. Refer to the manual for complete product specifications.

If the product is used in a manner not specified, the protection provided by the product may be impaired.

The types of product users are:

Responsible body is the individual or group responsible for the use and maintenance of equipment, for ensuring that the equipment is operated within its specifications and operating limits, and for ensuring that operators are adequately trained.

Operators use the product for its intended function. They must be trained in electrical safety procedures and proper use of the instrument. They must be protected from electric shock and contact with hazardous live circuits.

Maintenance personnel perform routine procedures on the product to keep it operating properly, for example, setting the line voltage or replacing consumable materials. Maintenance procedures are described in the manual. The procedures explicitly state if the operator may perform them. Otherwise, they should be performed only by service personnel.

Service personnel are trained to work on live circuits, and perform safe installations and repairs of products. Only properly trained service personnel may perform installation and service procedures.

Keithley products are designed for use with electrical signals that are rated Installation Category I and Installation Category II, as described in the International Electrotechnical Commission (IEC) Standard IEC 60664. Most measurement, control, and data I/O signals are Installation Category I and must not be directly connected to mains voltage or to voltage sources with high transient over-voltages. Installation Category II connections require protection for high transient over-voltages often associated with local AC mains connections. Assume all measurement, control, and data I/O connections are for connection to Category I sources unless otherwise marked or described in the Manual.

Exercise extreme caution when a shock hazard is present. Lethal voltage may be present on cable connector jacks or test fixtures. The American National Standards Institute (ANSI) states that a shock hazard exists when voltage levels greater than 30V RMS, 42.4V peak, or 60VDC are present. **A good safety practice is to expect that hazardous voltage is present in any unknown circuit before measuring.**

Operators of this product must be protected from electric shock at all times. The responsible body must ensure that operators are prevented access and/or insulated from every connection point. In some cases, connections must be exposed to potential human contact. Product operators in these circumstances must be trained to protect themselves from the risk of electric shock. If the circuit is capable of operating at or above 1000 volts, **no conductive part of the circuit may be exposed.**

Do not connect switching cards directly to unlimited power circuits. They are intended to be used with impedance limited sources. NEVER connect switching cards directly to AC mains. When connecting sources to switching cards, install protective devices to limit fault current and voltage to the card.

Before operating an instrument, make sure the line cord is connected to a properly grounded power receptacle. Inspect the connecting cables, test leads, and jumpers for possible wear, cracks, or breaks before each use.

When installing equipment where access to the main power cord is restricted, such as rack mounting, a separate main input power receptacle may be provided, in close proximity to the equipment and within easy reach of the operator.

For maximum safety, do not touch the product, test cables, or any other instruments while power is applied to the circuit under test. ALWAYS remove power from the entire test system and discharge any capacitors before: connecting or disconnecting ca-

bles or jumpers, installing or removing switching cards, or making internal changes, such as installing or removing jumpers.

Do not touch any object that could provide a current path to the common side of the circuit under test or power line (earth) ground. Always make measurements with dry hands while standing on a dry, insulated surface capable of withstanding the voltage being measured.

The instrument and accessories must be used in accordance with its specifications and operating instructions or the safety of the equipment may be impaired.

Do not exceed the maximum signal levels of the instruments and accessories, as defined in the specifications and operating information, and as shown on the instrument or test fixture panels, or switching card.

When fuses are used in a product, replace with same type and rating for continued protection against fire hazard.

Chassis connections must only be used as shield connections for measuring circuits, NOT as safety earth ground connections.

If you are using a test fixture, keep the lid closed while power is applied to the device under test. Safe operation requires the use of a lid interlock.

If a  screw is present, connect it to safety earth ground using the wire recommended in the user documentation.

The  symbol on an instrument indicates that the user should refer to the operating instructions located in the manual.

The  symbol on an instrument shows that it can source or measure 1000 volts or more, including the combined effect of normal and common mode voltages. Use standard safety precautions to avoid personal contact with these voltages.

The **WARNING** heading in a manual explains dangers that might result in personal injury or death. Always read the associated information very carefully before performing the indicated procedure.

The **CAUTION** heading in a manual explains hazards that could damage the instrument. Such damage may invalidate the warranty.

Instrumentation and accessories shall not be connected to humans.

Before performing any maintenance, disconnect the line cord and all test cables.

To maintain protection from electric shock and fire, replacement components in mains circuits, including the power transformer, test leads, and input jacks, must be purchased from Keithley Instruments. Standard fuses, with applicable national safety approvals, may be used if the rating and type are the same. Other components that are not safety related may be purchased from other suppliers as long as they are equivalent to the original component. (Note that selected parts should be purchased only through Keithley Instruments to maintain accuracy and functionality of the product.) If you are unsure about the applicability of a replacement component, call a Keithley Instruments office for information.

To clean an instrument, use a damp cloth or mild, water based cleaner. Clean the exterior of the instrument only. Do not apply cleaner directly to the instrument or allow liquids to enter or spill on the instrument. Products that consist of a circuit board with no case or chassis (e.g., data acquisition board for installation into a computer) should never require cleaning if handled according to instructions. If the board becomes contaminated and operation is affected, the board should be returned to the factory for proper cleaning/servicing.

Table of Contents

1	Performance Verification	
	Introduction	1-2
	Verification test requirements	1-2
	Environmental conditions	1-2
	Warm-up period	1-2
	Line power	1-3
	Recommended test equipment	1-3
	Resistor characterization	1-4
	Verification limits	1-4
	Example limits calculation	1-4
	Resistance limits calculation	1-4
	Restoring factory defaults	1-5
	Performing the verification test procedures	1-5
	Test summary	1-5
	Test considerations	1-6
	Adjusting setpoints	1-6
	Voltage accuracy	1-6
	Output voltage accuracy	1-6
	Voltage readback accuracy	1-7
	Voltage limit accuracy	1-8
	Current accuracy	1-8
	Output current accuracy	1-8
	Current readback accuracy	1-9
	Current limit accuracy	1-10
	AC resistance accuracy	1-10
	Sensor measurement accuracy	1-11
2	Calibration	
	Introduction	2-2
	Environmental conditions	2-2
	Temperature and relative humidity	2-2
	Warm-up period	2-2
	Line power	2-2
	Calibration considerations	2-3
	Calibration cycle	2-3
	Recommended calibration equipment	2-3
	Resistor characterization	2-4
	Calibration menu	2-5
	Unlocking calibration	2-5
	Unlocking calibration from the front panel	2-5
	Unlocking calibration by remote	2-6

Changing the password	2-6
Changing the password from the front panel	2-6
Changing the password by remote	2-6
Resetting the calibration password	2-7
Viewing calibration dates and calibration count	2-7
Calibration errors	2-7
Front panel error reporting	2-7
Remote error reporting	2-7
Aborting calibration steps	2-8
Front panel calibration	2-8
Remote calibration	2-20
Remote calibration command summary	2-20
Remote calibration procedure	2-21

3 Routine Maintenance

Introduction	3-2
Line fuse replacement	3-2

4 Troubleshooting

Introduction	4-2
Safety considerations	4-2
Repair considerations	4-2
Power-on self-test	4-3
Front panel tests	4-3
KEYS test	4-3
DISPLAY PATTERNS test	4-4
CHAR SET test	4-4
Principles of operation	4-5
Overall block diagram	4-5
Analog circuits	4-6
Power supply	4-12
Digital circuitry	4-13
Display board circuits	4-15
Troubleshooting	4-15
Display board checks	4-15
Power supply checks	4-16
Digital circuitry checks	4-16
Analog circuitry checks	4-17
Internal fuse replacement	4-17
Power supply module fuse replacement	4-17
Digital I/O +5V supply fuse replacement	4-18
No comm link error	4-18

5	Disassembly	
	Introduction	5-2
	Handling and cleaning	5-2
	Handling PC boards	5-2
	Solder repairs	5-2
	Static sensitive devices	5-3
	Assembly drawings	5-3
	Case cover removal	5-4
	Mother board removal	5-4
	Front panel disassembly	5-5
	Removing power components	5-5
	Power supply module removal	5-5
	Power module removal	5-6
	Fan removal	5-6
	Instrument reassembly	5-6

6	Replaceable Parts	
	Introduction	6-2
	Parts lists	6-2
	Ordering information	6-2
	Factory service	6-2
	Component layouts	6-2

A Specifications

B	Calibration Reference	
	Introduction	B-2
	Command summary	B-2
	Miscellaneous commands	B-3
	SENSe commands	B-6
	SOURce commands	B-8
	DAC commands	B-9
	RESistance commands	B-9
	Detecting calibration errors	B-10
	Reading the error queue	B-10
	Error summary	B-10
	Status byte EAV (Error Available) bit	B-10
	Generating an SRQ on error	B-10
	Detecting calibration step completion	B-12
	Using the *OPC? query	B-12
	Using the *OPC command	B-12
	Generating an SRQ on calibration complete	B-13

C**Calibration Program**

Introduction	C-2
Computer hardware requirements	C-2
Software requirements	C-2
Calibration equipment	C-2
General program instructions	C-3
Program C-1 Model 2510 calibration program	C-4

List of Illustrations

1 Performance Verification

Figure 1-1	Connections for voltage verification tests	1-7
Figure 1-2	Connections for current verification tests	1-9
Figure 1-3	Connections for AC resistance verification test	1-11
Figure 1-4	Connections for sensor resistance accuracy verification	1-12

2 Calibration

Figure 2-1	Voltage calibration connections	2-9
Figure 2-2	Current and current protection calibration connections	2-11
Figure 2-3	Thermistor and RTD calibration resistor connections	2-12
Figure 2-4	Shorted input calibration connections	2-13
Figure 2-5	I-SS and V-SS calibration resistor connections	2-17
Figure 2-6	AC ohms calibration connections	2-18

3 Routine Maintenance

Figure 3-1	Rear panel	3-2
------------	------------------	-----

4 Troubleshooting

Figure 4-1	Overall block diagram	4-5
Figure 4-2	Block diagram of analog circuits	4-6
Figure 4-3	Simplified schematic of class D amplifier	4-7
Figure 4-4	Simplified schematic of H-bridge output stage	4-8
Figure 4-5	H-bridge switching and step-down regulator	4-9
Figure 4-6	Sensor conditioning for 10k Ω thermistor	4-10
Figure 4-7	PID hardware control loop	4-11
Figure 4-8	Power supply block diagram	4-12
Figure 4-9	Digital circuitry overall block diagram	4-13
Figure 4-10	Digital control circuits	4-14

List of Tables

1	Performance Verification	
Table 1-1	Recommended verification equipment	1-3
Table 1-2	Characterized resistor values	1-4
Table 1-3	Sensor resistance measurement accuracy limits	1-13
2	Calibration	
Table 2-1	Recommended calibration equipment	2-4
Table 2-2	Characterized resistor values	2-4
Table 2-3	Calibration menu	2-5
Table 2-4	Calibration step summary	2-9
Table 2-5	Remote calibration command summary	2-20
Table 2-6	Remote calibration step summary	2-21
3	Routine Maintenance	
Table 3-1	Power line fuse	3-3
4	Troubleshooting	
Table 4-1	Display board checks	4-15
Table 4-2	Power supply checks	4-16
Table 4-3	Digital circuitry checks	4-16
Table 4-4	Analog circuitry checks	4-17
6	Replaceable Parts	
Table 6-1	Mother board parts list	6-3
Table 6-2	Display board parts list	6-9
Table 6-3	Miscellaneous parts list	6-10
B	Calibration Reference	
Table B-1	Calibration commands	B-2
Table B-2	Calibration errors	B-11

1 Performance Verification

Introduction

Use the procedures in this section to verify that Model 2510 accuracy is within the limits stated in the instrument's one-year accuracy specifications. You can perform these verification procedures:

- When you first receive the instrument to make sure that it was not damaged during shipment.
- To verify that the unit meets factory specifications.
- To determine if calibration is required.
- Following calibration to make sure it was performed properly.

WARNING The information in this section is intended for qualified service personnel only. Do not attempt these procedures unless you are qualified to do so. Some of these procedures may expose you to hazardous voltages, which could cause personal injury or death if contacted. Use standard safety precautions when working with hazardous voltages.

NOTE *If the instrument is still under warranty and its performance is outside specified limits, contact your Keithley representative or the factory to determine the correct course of action.*

Verification test requirements

Be sure that you perform the verification tests:

- Under the proper environmental conditions.
- After the specified warm-up period.
- Using the correct line voltage.
- Using the proper test equipment.
- Using the specified output signals and reading limits.

Environmental conditions

Conduct your performance verification procedures in a test environment with:

- An ambient temperature of 18-28°C (65-82°F).
- A relative humidity of less than 70% unless otherwise noted.

Warm-up period

Allow the Model 2510 to warm up for at least one hour before conducting the verification procedures.

If the instrument has been subjected to temperature extremes (those outside the ranges stated above), allow additional time for the instrument's internal temperature to stabilize. Typically, allow one extra hour to stabilize a unit that is 10°C (18°F) outside the specified temperature range.

Also, allow the test equipment to warm up for the minimum time specified by the manufacturer.

Line power

The Model 2510 requires a line voltage of 100 to 240V and a line frequency of 50 or 60Hz. Verification tests must be performed within this range.

Recommended test equipment

Table 1-1 summarizes recommended verification equipment and pertinent specifications. You can use alternate equipment as long as that equipment has specifications at least as good as those listed in Table 1-1. Keep in mind, however, that test equipment uncertainty will add to the uncertainty of each measurement. Generally, test equipment uncertainty should be at least four times better than corresponding Model 2510 specifications.

Table 1-1
Recommended verification equipment

Description	Manufacturer/Model	Specifications
Digital Multimeter	Keithley 2002	DC Voltage ¹ 20V: ±6.8ppm Resistance ¹ 20Ω: ±23ppm 200Ω: ±19ppm 2kΩ: ±7.4ppm 20kΩ: ±7.4ppm 200kΩ: ±29.8ppm
Resistors ²	Isotec RUG-Z-1R00-0.1	1Ω, ±0.1%, 100W 100Ω, ±1% 1kΩ, ±1% 10kΩ, ±1% 100kΩ, ±1%
INPUT/OUTPUT Mating Connector ³	Keithley CS-846	

1. Ninety day, full-range accuracy specification of ranges required for various measurement points.
2. Characterize all resistors using 4-wire ohms function of recommended DMM before use.
3. One connector supplied with Model 2510.

Resistor characterization

The resistors listed in Table 1-1 must be characterized using the 4-wire ohms function of the recommended DMM before use. Be sure to use the lowest resistance range possible for each measurement for best accuracy. Characterized values can be recorded in Table 1-2.

Table 1-2
Characterized resistor values

Nominal resistance	Characterized resistance*
1Ω	_____Ω
100Ω	_____Ω
1kΩ	_____kΩ
10kΩ	_____kΩ
100kΩ	_____kΩ

*Characterize value using DMM (see Table 1-1).

Verification limits

The verification limits stated in this section have been calculated using only the Model 2510 one-year accuracy specifications, and they do not include test equipment uncertainty. If a particular measurement falls outside the allowable range, recalculate new limits based on Model 2510 specifications and corresponding test equipment specifications.

Example limits calculation

As an example of how verification limits are calculated, assume you are testing the operating voltage function using a 10V value. Using the Model 2510 operating voltage one-year accuracy specification of $\pm(0.1\%$ of reading + 4mV offset), the calculated output limits are:

$$\text{Limits} = 10\text{V} \pm [(10\text{V} \times 0.1\%) + 4\text{mV}]$$

$$\text{Limits} = 10\text{V} \pm (0.01 + 0.004)$$

$$\text{Limits} = 10\text{V} \pm 0.014\text{V}$$

$$\text{Limits} = 9.986 \text{ to } 10.014\text{V}$$

Resistance limits calculation

When verifying accuracy for tests using the precision resistors, it will be necessary to recalculate resistance limits based on the actual characterized resistance values. You can calculate resistance reading limits in the same manner described above, but be sure to use the actual characterized resistance values and the Model 2510 one-year accuracy specifications for your calculations (see Appendix A).

Restoring factory defaults

Before performing the verification procedures, restore the instrument to its factory front panel (BENCH) defaults as follows:

1. Press the MENU key. The instrument will display the following prompt:
MAIN MENU
SAVESETUP COMMUNICATION CAL ►
2. Select SAVESETUP, and then press ENTER. The unit then displays:
SAVESETUP MENU
SAVE RESTORE POWERON RESET
3. Select RESET, and then press ENTER. The unit displays:
RESET ORIGINAL DFLTS
BENCH GPIB
4. Select BENCH, and then press ENTER to restore BENCH defaults.

Performing the verification test procedures

Test summary

- Voltage accuracy
- Current accuracy
- AC resistance accuracy
- Sensor measurement accuracy

If the Model 2510 is not within specifications and not under warranty, see the calibration procedures in Section 2 for information on calibrating the unit.

Test considerations

WARNING The maximum common-mode voltage (voltage between INPUT/OUTPUT - terminals and chassis ground) is 30V DC. Exceeding this value may cause a shock hazard.

CAUTION The maximum voltage between INPUT/OUTPUT sense (S) terminals is 1V. Exceeding this voltage may result in instrument damage.

When performing the verification procedures:

- Be sure to restore factory front panel defaults as previously outlined.
- Make sure that the test equipment is fully warmed up and properly connected to the Model 2510 INPUT or OUTPUT terminals as required.
- Be sure that the Model 2510 output is turned on before making measurements.
- Be sure the test equipment is set up for the proper function and range.
- Allow the Model 2510 output signal to settle before making a measurement.
- Do not connect test equipment to the Model 2510 through a scanner, multiplexer, or other switching equipment.

Adjusting setpoints

Before making many verification measurements, you must properly adjust the setpoint as covered below.

1. First select the function to be tested as indicated in the procedure.
2. Press any one of the four EDIT keys (◀, ▶, ▲, ▼) to enter the setpoint edit mode.
3. Using the EDIT keys, adjust the setpoint to the required value.

Voltage accuracy

Output voltage accuracy

Follow the steps below to verify that Model 2510 output voltage accuracy is within specified limits. This test involves setting the output voltage to a specific value and accurately measuring the voltage with a DMM.

1. With the power off, connect the digital multimeter to the Model 2510 OUTPUT terminals, as shown in Figure 1-1.
2. Turn on the Model 2510 and DMM, and allow them to warm up for at least one hour.
3. Select the multimeter DC volts measuring function, and choose the 20V range.
4. Press the Model 2510 V key to select the voltage function, and make sure the source output is turned on.

5. Using the EDIT keys, adjust the Model 2510 voltage setpoint to exactly +9.000V.
6. Verify that the DMM reading is within 8.987 to 9.013V limits.
7. Repeat steps 5 and 6 for a -9.000V output value.
8. Turn off the output when the test is completed.

Figure 1-1
Connections for voltage
verification tests

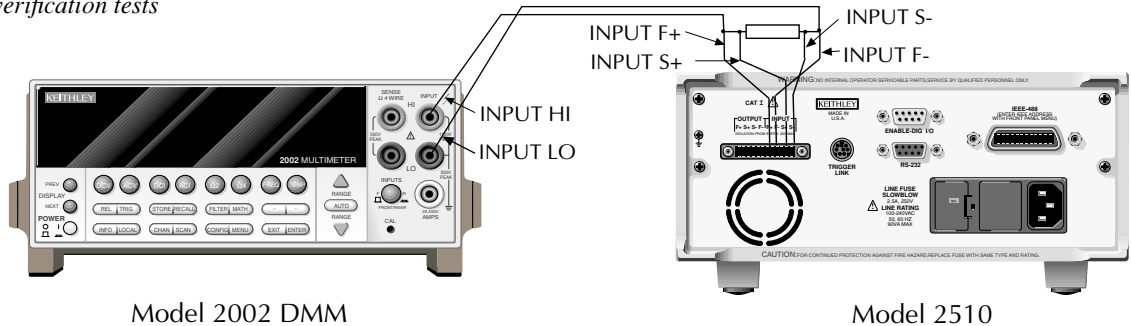

Voltage readback accuracy

Follow the steps below to verify that Model 2510 voltage readback accuracy is within specified limits. This test involves setting the output voltage to a specific value as measured by a DMM and verifying that the Model 2510 voltage readback display reading is within limits.

1. With the power off, connect the digital multimeter to the Model 2510 OUTPUT terminals, as shown in Figure 1-1.
2. Turn on the Model 2510 and DMM, and allow them to warm up for at least one hour.
3. Select the multimeter DC volts measuring function, and choose the 20V range.
4. Press the Model 2510 V key to select the voltage function, and make sure the source output is turned on.
5. Using the EDIT keys, adjust the Model 2510 output voltage as measured by the DMM to +9.000V (or closest possible value).
6. Verify that the Model 2510 readback display (top display line) is within 8.987 to 9.013V limits.
7. Repeat steps 5 and 6 for a -9.000V output value.
8. Turn off the output when the test is completed.

Voltage limit accuracy

Follow the steps below to verify that Model 2510 voltage limit accuracy is within specified limits. The test involves setting the voltage limit to a specific value and making sure the output voltage is limited to the required value.

1. With the power off, connect the digital multimeter to the Model 2510 OUTPUT terminals, as shown in Figure 1-1.
2. Turn on the Model 2510 and the DMM, and allow them to warm up for one hour.
3. Select the multimeter DC voltage measuring function, and set the unit to the 20V range.
4. Press the Model 2510 V key to select the voltage function.
5. Using the EDIT keys, adjust the Model 2510 voltage setpoint to +10.000V.
6. Press CONFIG then V, select PROTECTION, then set the voltage limit to 9.00V.
7. Turn the source output on.
8. Verify that the “VLIM” message is displayed, then note the DMM voltage reading.
9. Verify that the voltage measured in step 8 is within 8.55 to 9.45V limits.
10. Turn off the output when the test is completed.

Current accuracy

Output current accuracy

Follow the steps below to verify that Model 2510 output current accuracy is within specified limits. The test involves setting the output current to a specific value and measuring the current using a 1 Ω resistor and a digital multimeter.

1. With the power off, connect the digital multimeter and 1 Ω resistor to the Model 2510 OUTPUT terminals, as shown in Figure 1-2.
2. Turn on the Model 2510 and the DMM, and allow them to warm up for one hour.
3. Select the multimeter DC voltage measuring function, and set the unit to the 20V range.
4. Press CONFIG then I, choose PROTECTION, then set the current limit to 5.00A.
5. Press the Model 2510 I key to select the current function, and make sure the source output is turned on.
6. Using the EDIT keys, adjust the Model 2510 setpoint to exactly +4.5000A. Compute the current as follows: $I = V/R$, where V is the DMM voltage reading, and R is the characterized value of the 1 Ω resistor.
7. Verify that the current calculated in step 6 is within 4.474 to 4.526A limits.
8. Repeat steps 6 and 7 for an output current of -4.5000A.
9. Turn off the output when the test is completed.

Figure 1-2
Connections for current
verification tests

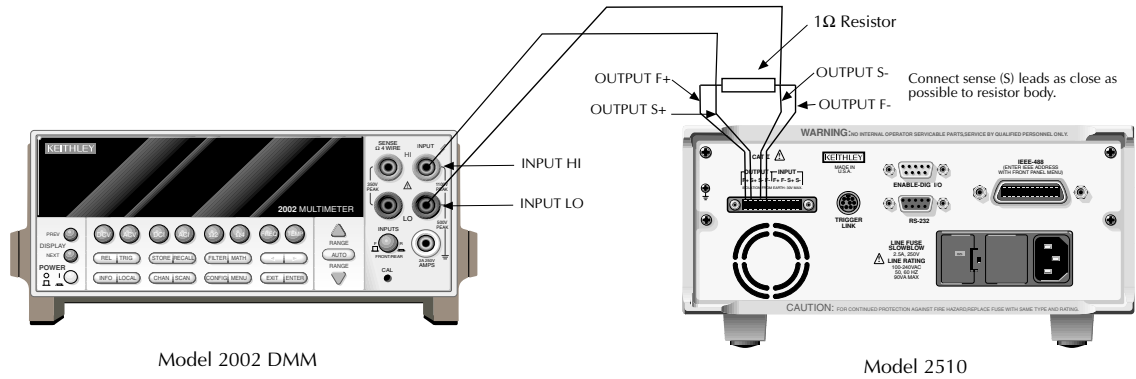

Current readback accuracy

Follow the steps below to verify that Model 2510 current readback accuracy is within specified limits. The test involves setting the output current to a specific value using a 1Ω resistor and a digital multimeter.

1. With the power off, connect the digital multimeter and 1Ω resistor to the Model 2510 OUTPUT terminals, as shown in Figure 1-2.
2. Turn on the Model 2510 and the DMM, and allow them to warm up for one hour.
3. Select the multimeter DC voltage measuring function, and set the unit to the 20V range.
4. Press CONFIG then I, choose PROTECTION, then set the current limit to 5.00A.
5. Press the Model 2510 I key to select the current function, and make sure the source output is turned on.
6. Using the EDIT keys, adjust the Model 2510 output current to +4.5000A, as determined from the DMM voltage reading and resistor value. Compute the current as follows:

$$I = V/R$$
 where V is the DMM voltage reading, and R is the characterized value of the 1Ω resistor.
7. Verify that the current calculated in step 6 is within 4.474 to 4.526A limits.
8. Repeat steps 6 and 7 for an output current of -4.5000A.

Current limit accuracy

Follow the steps below to verify that Model 2510 current limit accuracy is within specified limits. The test involves setting the current limit to a specific value and making sure the current is limited to the required value.

1. With the power off, connect the digital multimeter and 1 Ω resistor to the Model 2510 OUTPUT terminals, as shown in Figure 1-2.
2. Turn on the Model 2510 and the DMM, and allow them to warm up for one hour.
3. Select the multimeter DC voltage measuring function, and set the unit to the 20V range.
4. Press the Model 2510 V key to select the voltage function.
5. Press CONFIG then I, select PROTECTION, then set the current limit to 4.50A.
6. Make sure the source output is turned on.
7. Using the EDIT keys, adjust the Model 2510 output voltage to +10.000V.
8. Verify that the "ILIM" message is displayed, then measure the output current, as determined from the DMM voltage reading and resistor value. Compute the current as follows: $I = V/R$, where V is the DMM voltage reading, and R is the characterized value of the 1 Ω resistor.
9. Verify that the current calculated in step 9 is within 4.275 to 4.725A limits.
10. Turn off the output when the test is completed.

AC resistance accuracy

Follow the steps below to verify that Model 2510 AC resistance accuracy is within specified limits. The test involves connecting a 100 Ω resistor to the OUTPUT terminals and verifying that the Model 2510 AC resistance reading is within limits.

1. With the power off, connect the 100 Ω resistor to the Model 2510 OUTPUT terminals, as shown in Figure 1-3.
2. Connect the Model 2510 to the serial port or IEEE-488 interface of the computer.
3. Turn on the Model 2510, and allow it to warm up for one hour before testing.
4. Press CONFIG then R.
5. Select AC-OHMS, then press ENTER.
6. Note the reading, and verify that the resistance measurement is within required limits. (Recalculate limits using the characterized resistance value and Model 2510 AC resistance specifications.) For a 100 Ω resistance, the limits are: 99.88 to 100.12 Ω .

Figure 1-3
Connections for
AC resistance
verification test

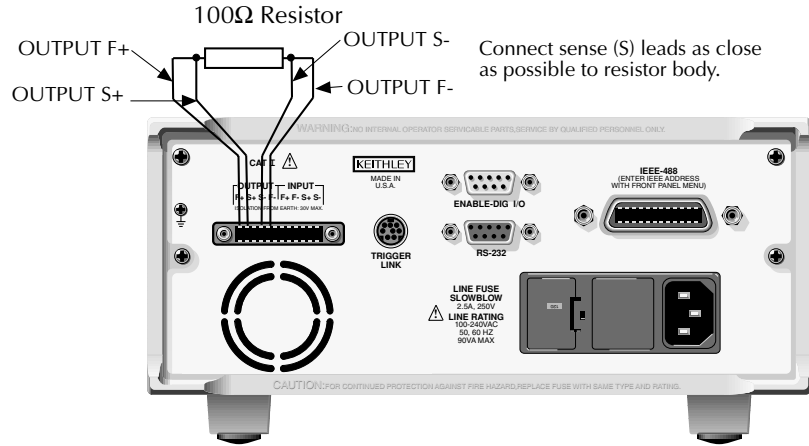

Sensor measurement accuracy

Use the following steps to verify that Model 2510 temperature sensor measurement accuracy is within specified limits. This procedure involves connecting characterized resistors to the INPUT terminals and verifying sensor resistance readings are within required limits.

NOTE *The following procedure tests thermistor sensor accuracy and will verify sensor measurement accuracy for all sensor types.*

1. With the power off, connect the 100Ω characterized resistor to the Model 2510 INPUT terminals, as shown in Figure 1-4.
2. Turn on the Model 2510, and allow it to warm up for one hour before testing.
3. Select the Model 2510 voltage function by pressing the V key.

Figure 1-4
Connections for sensor
resistance accuracy
verification

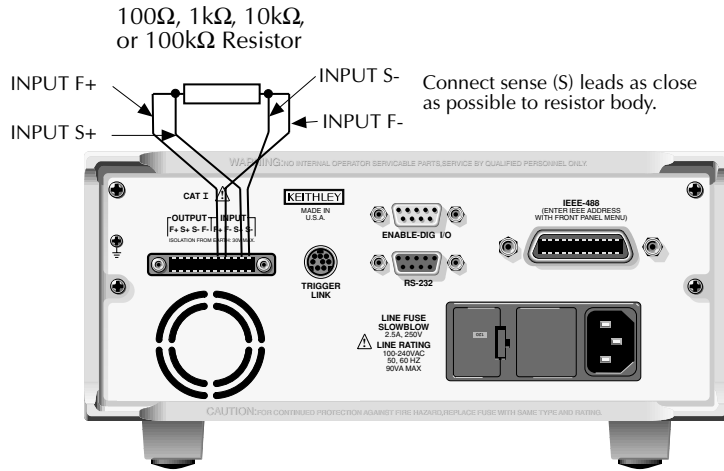

Model 2510

4. Configure the Model 2510 for thermistor sensor type, resistance range, and 4-wire sense mode as follows:
 - Press CONFIG then T. The instrument will display the following:
CONFIG TEMPERATURE
PROTECTION SENSOR-TYPE UNITS PID
 - Select SENSOR-TYPE, and then press ENTER. The following will be displayed:
SENSOR TYPE
THERMISTOR RTD I-SS V-SS
 - Select THERMISTOR, and then press ENTER. The following will be displayed:
THERMISTOR SETTINGS
RANGE A B C I-SRC ►
 - Select RANGE, then press ENTER. The unit displays:
THERMISTOR RANGE
100 1K 10K 100K
 - Select 100, then press ENTER.
 - From the THERMISTOR SETTINGS menu, choose SENSE-MODE, then press ENTER.
 - From the SENSE MODE menu, choose 4-WIRE, then press ENTER.
 - Press EXIT as required to return to normal display.
5. Repeatedly press the DISPLAY TOGGLE key until the sensor resistance (RT) is displayed on the lower display line on the right. For example: RT: +099.98Ω.
6. Verify that the sensor reading for the 100Ω resistance in Table 1-3 is within stated limits.

NOTE The reading limits in Table 1-3 are based on nominal resistance values. Recalculate new limits based on characterized resistance values and Model 2510 one-year thermistor sensor accuracy specifications (see Appendix A).

- Repeat steps 1 through 5 for the remaining resistance values in Table 1-3. Be sure to select the correct resistance range from the THERMISTOR RANGE menu.

Table 1-3

Sensor resistance measurement accuracy limits

Sensor range	Test resistance ¹	Model 2510 sensor reading limits ² (1 year, 18°C-28°C)
100Ω	100Ω	99.89 to 100.11Ω
1kΩ	1kΩ	0.9992 to 1.0008kΩ
10kΩ	10kΩ	9.995 to 10.005kΩ
100kΩ	100kΩ	99.939 to 100.061kΩ

- Nominal resistance values.
- Reading limits based on Model 2510 1-year accuracy specifications and nominal resistance values. Recalculate reading limits using actual characterized resistance values and Model 2510 1-year accuracy specifications. See “Verification limits” earlier in this section for details.

2 Calibration

Introduction

Use the procedures in this section to calibrate the Model 2510. These procedures require accurate test equipment to measure precise DC voltages and resistances. Calibration can be performed either from the front panel or by sending SCPI calibration commands over the IEEE-488 bus or RS-232 port with the aid of a computer.

WARNING The information in this section is intended for qualified service personnel only. Do not attempt these procedures unless you are qualified to do so. Some of these procedures may expose you to hazardous voltages.

Environmental conditions

Temperature and relative humidity

Conduct the calibration procedures at an ambient temperature of 18-28°C (65-82°F) with relative humidity of less than 70% unless otherwise noted.

Warm-up period

Allow the Model 2510 to warm up for at least one hour before performing calibration.

If the instrument has been subjected to temperature extremes (those outside the ranges stated above), allow additional time for the instrument's internal temperature to stabilize. Typically, allow one extra hour to stabilize a unit that is 10°C (18°F) outside the specified temperature range.

Allow the test equipment to warm up for the minimum time specified by the manufacturer.

Line power

The Model 2510 requires a line voltage of 100 to 240V at line frequency of 50 or 60Hz. The instrument must be calibrated while operating from a line voltage within this range.

Calibration considerations

WARNING The maximum common-mode voltage (voltage between INPUT/OUTPUT - terminals and chassis ground) is 30V DC. Exceeding this value may cause a shock hazard.

CAUTION The maximum voltage between INPUT/OUTPUT sense (S) terminals is 1V. Exceeding this voltage may result in instrument damage.

When performing the calibration procedures:

- Make sure that the test equipment is properly warmed up and connected to the Model 2510 INPUT or OUTPUT terminals as required.
- Always allow the source signal to settle before calibrating each point.
- Do not connect test equipment to the Model 2510 through a scanner or other switching equipment.
- If an error occurs during calibration, the Model 2510 will generate an appropriate error message. See Appendix B for more information.

Calibration cycle

Perform calibration at least once a year to ensure the unit meets or exceeds its specifications.

Recommended calibration equipment

Table 2-1 lists the recommended equipment for the calibration procedures. You can use alternate equipment as long that equipment has specifications at least as good as those listed in the table. For optimum calibration accuracy, test equipment specifications should be at least four times better than corresponding Model 2510 specifications.

Table 2-1
Recommended calibration equipment

Description	Manufacturer/Model	Specifications
Digital Multimeter	Keithley 2002	DC Voltage ¹ 20V: ±6.8ppm Resistance ¹ 20Ω: ±23ppm 200Ω: ±19ppm 2kΩ: ±7.4ppm 20kΩ: ±7.4ppm 200kΩ: ±29.8ppm
Resistors ²	Isotec RUG-Z-1R00-0.1	1Ω, ±0.1%, 100W 100Ω, ±1% 1kΩ, ±1% 10kΩ, ±1% 100kΩ, ±1%
INPUT/OUTPUT Mating Connector ³	Keithley CS-846	
Clean Copper Wire		#18-22 AWG

3. Ninety day, full-range accuracy specification of ranges required for various measurement points.
4. Characterize all resistors using 4-wire ohms function of recommended DMM before use.
5. One connector supplied with Model 2510.

Resistor characterization

The resistors listed in Table 2-1 must be characterized using the 4-wire ohms function of the recommended DMM before use. Be sure to use the lowest resistance range possible for each measurement for best accuracy. Record the characterized values in Table 2-2.

Table 2-2
Characterized resistor values

Nominal resistance	Characterized resistance*
1Ω	_____Ω
100Ω	_____Ω
1kΩ	_____kΩ
10kΩ	_____kΩ
100kΩ	_____kΩ

*Characterize value using DMM (see Table 2-1).

Calibration menu

Table 2-3 summarizes the main calibration menu selections. To enter the calibration menu, press the MENU key, select CAL, then press ENTER. Use the EDIT keys to move the cursor and scroll through menu selections. Press ENTER to select a MENU item.

Table 2-3
Calibration menu

Menu selection	Description
UNLOCK	Unlock calibration using password (default: 002510).
EXECUTE	Execute calibration steps.
VOLTAGE	Voltage calibration.
CURRENT	Current calibration.
I-PROTECTION	Current protection calibration.
TEMPERATURE	Temperature calibration.
AC-OHMS	AC resistance calibration.
V-SOURCE	Voltage source calibration.
VIEW-DATES	View calibration dates.
SAVE	Save calibration constants.
LOCK	Lock out calibration.
CHANGE-PASSWORD	Change calibration password.

Unlocking calibration

Before performing calibration, you must first unlock calibration by entering or sending the calibration password as explained in the following paragraphs.

Unlocking calibration from the front panel

1. Press the MENU key, choose CAL, and press ENTER. The instrument will display the following:
CALIBRATION
UNLOCK EXECUTE VIEW-DATES ►
◀ SAVE LOCK CHANGE-PASSWORD
2. Select UNLOCK, and then press ENTER. The instrument will display the following:
PASSWORD:
Use ◀, ▶, ▲, ▼, ENTER or EXIT.
3. Use the ▲ and ▼ keys to select the letter or number, and use the ◀ and ▶ arrow keys to choose the position. (Press ▼ for letters; ▲ for numbers.) Enter the present password on the display. (Front panel default: 002510.)
4. Once the correct password is displayed, press the ENTER key. You can then proceed with the calibration procedure.

Unlocking calibration by remote

To unlock calibration via remote, send the following command:

```
:CAL:PROT:CODE '<password>'
```

For example, the following command uses the default password:

```
:CAL:PROT:CODE 'KI002510'
```

Changing the password

The default password (002510) may be changed from the front panel or via remote as discussed.

Changing the password from the front panel

Follow the steps below to change the password from the front panel:

1. Press the MENU key, choose CAL, and press ENTER. The instrument will display the following:
CALIBRATION
UNLOCK EXECUTE VIEW-DATES ►
◀ SAVE LOCK CHANGE-PASSWORD
2. Select UNLOCK, then enter the password. (Default: 002510.)
3. Select CHANGE-PASSWORD, and then press ENTER. The instrument will display the following:
New Pwd: 002510
Use ◀, ▶, ▲, ▼, ENTER or EXIT.
4. Using the EDIT keys, enter the new password on the display.
5. Once the desired password is displayed, press the ENTER key to store the new password.

Changing the password by remote

To change the calibration password by remote, first send the present password, and then send the new password. For example, the following command sequence changes the password from the 'KI002510' remote default to 'KI_CAL':

```
:CAL:PROT:CODE 'KI002510'  
:CAL:PROT:CODE 'KI_CAL'
```

You can use any combination of letters and numbers up to a maximum of eight characters.

NOTE If you change the first two characters of the password to something other than “KI”, you will not be able to unlock calibration from the front panel.

Resetting the calibration password

If you lose the calibration password, you can unlock calibration by shorting together the CAL pads, which are located on the display board. Doing so will reset the password to the factory default (002510, front panel; KI002510, remote).

See Section 5 for details on disassembling the unit to access the CAL pads. Refer to the display board component layout drawing at the end of Section 6 for the location of the CAL pads.

Viewing calibration dates and calibration count

When calibration is locked, only the UNLOCK and VIEW-DATES selections will be accessible in the calibration menu. To view calibration dates and calibration count at any time:

1. From normal display, press MENU, select CAL, then press ENTER. The unit will display the following:
CALIBRATION
UNLOCK EXECUTE VIEW-DATES ►
2. Select VIEW-DATES, and then press ENTER. The Model 2510 will display the next and last calibration dates and the calibration count as in the following example:
NEXT CAL: 02/15/2001
Last calibration: 02/15/2000 Count: 0001

Calibration errors

The Model 2510 checks for errors after each calibration step, minimizing the possibility that improper calibration may occur due to operator error.

Front panel error reporting

If an error is detected during comprehensive calibration, the instrument will display an appropriate error message (see Appendix B). The unit will then prompt you to repeat the calibration step that caused the error.

Remote error reporting

You can detect errors while in remote by testing the state of EAV (Error Available) bit (bit 2) in the status byte. (Use the *STB? query to request the status byte.) Query the instrument for the type of error by using the :SYST:ERR? query. The Model 2510 will respond with the error number and a text message describing the nature of the error. See Appendix B for details.

Aborting calibration steps

To abort a calibration step from the front panel, press the EXIT key. To abort a calibration step via remote, send the :ABORt command.

Front panel calibration

The front panel calibration procedure described below calibrates all functions. Note that each function is separately calibrated, and the procedure must be performed in the order shown.

Step 1: Prepare the Model 2510 for calibration

1. Turn on the Model 2510 and the digital multimeter, and allow them to warm up for at least one hour before performing calibration.
2. Configure the INPUT terminals for 4-wire sensing as follows:
 - Press CONFIG then T.
 - Select SENSOR-TYPE, then press ENTER.
 - Choose THERMISTOR, then press ENTER.
 - Select SENSE-MODE, then press ENTER.
 - Choose 4-WIRE, then press ENTER.
 - Press EXIT as required to back out of the menu structure and return to normal display.
3. Press the MENU key, choose CAL, and press ENTER. Select UNLOCK, and then press ENTER. The instrument will display the following:
PASSWORD:
Use ◀, ▶, ▲, ▼, ENTER or EXIT.
4. Use the ▲ and ▼ keys to select the letter or number, and use the ◀ and ▶ arrow keys to choose the position. (Press ▼ for letters; ▲ for numbers.) Enter the present password on the display. (Front panel default: 002510.)
5. Press ENTER to complete the process.
6. Select EXECUTE, then press ENTER to enter the CAL EXECUTE menu. Table 2-4 summarizes the various menu selections and calibration steps, which are covered in more detail throughout the procedure.

Table 2-4
Calibration step summary

Function*	Calibration step	Test connections
VOLTAGE	Output +8.5V Output 0V Output -8.5V	DMM to OUTPUT terminals (Figure 2-1) DMM to OUTPUT terminals (Figure 2-1) DMM to OUTPUT terminals (Figure 2-1)
CURRENT	1 Ω resistor	1 Ω resistor to OUTPUT terminals (Figure 2-2)
I-PROTECTION	1 Ω resistor	1 Ω resistor to OUTPUT terminals (Figure 2-2)
TEMPERATURE THERMISTOR	100 Ω resistor, short 1k Ω resistor, short 10k Ω resistor, short 100k Ω resistor, short	100 Ω resistor then short to INPUT terminals (Figure 2-3 and Figure 2-4) 1k Ω resistor then short to INPUT terminals (Figure 2-3 and Figure 2-4) 10k Ω resistor then short to INPUT terminals (Figure 2-3 and Figure 2-4) 100k Ω resistor then short to INPUT terminals (Figure 2-3 and Figure 2-4)
RTD	100 Ω resistor, short 1k Ω resistor, short	100 Ω resistor then short to INPUT terminals (Figure 2-3 and Figure 2-4) 1k Ω resistor then short to INPUT terminals (Figure 2-3 and Figure 2-4)
I-SS	1k Ω resistor	DMM and 1k Ω resistor to INPUT terminals (Figure 2-5)
V-SS	1k Ω resistor, short	DMM, 1k Ω resistor; short to INPUT terminals (Figure 2-4 and Figure 2-5)
AC-OHMS	100 Ω resistor	100 Ω resistor to OUTPUT terminals (Figure 2-6)
V-SOURCE	Open leads	None (open OUTPUT terminals)

* CAL EXECUTE menu selections.

Step 2: Voltage calibration

- From the CAL EXECUTE menu, select VOLTAGE, then press ENTER. The instrument will display the following message:
VOLTAGE CAL
Connect only a DMM to Peltier. ►
◀ Then press ENTER.
- Connect the DMM to the Model 2510 OUTPUT terminals, as shown in Figure 2-1.

Figure 2-1
Voltage calibration
connections

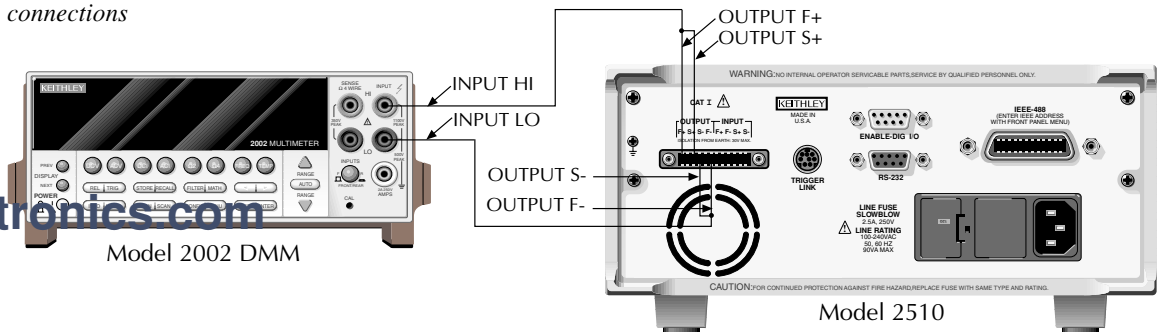

3. Select the DMM DC voltage function, and enable auto-range.
4. Press ENTER. The unit will then prompt for the +8.5V step:
VOLTAGE CAL
Press ENTER to output +8.5V

NOTE *The output will turn on automatically when you perform the next step.*

5. Press ENTER. The Model 2510 will source +8.5V and simultaneously display the following:
DMM RDG: +08.50000 V
Use ◀ ▶ ▲ ▼, ENTER or EXIT.
6. Note and record the DMM reading, and then use the EDIT keys to adjust the Model 2510 display to agree exactly with the actual DMM reading.
7. After adjusting the display to agree with the DMM reading, press ENTER. The instrument will then display the following:
VOLTAGE CAL
Press ENTER to output 0.0V
8. Press ENTER. The Model 2510 will source 0V and at the same time display the following:
DMM RDG: +00.00000 V
Use ◀ ▶ ▲ ▼, ENTER or EXIT.
9. Note and record the DMM reading, and then adjust the Model 2510 display to agree with that reading.
10. After adjusting the display value to agree with the DMM reading, press ENTER. The unit will then display the following:
VOLTAGE CAL
Press ENTER to output -8.5V
11. Press ENTER. The Model 2510 will source -8.5V and display the following:
DMM RDG: -08.50000 V
Use ◀ ▶ ▲ ▼, ENTER or EXIT.
12. Note and record the DMM reading, adjust the Model 2510 display to agree with the DMM reading, and press ENTER.
13. Disconnect the DMM from the OUTPUT terminals.

Step 3: Current and current protection calibration

1. From the CAL EXECUTE menu, select CURRENT, then press ENTER. The instrument will display the following message:
CURRENT CAL
Connect a 1Ω load to Peltier. ►
◀ Then press ENTER.
2. Connect the 1Ω resistor to the Model 2510 OUTPUT terminals, as shown in Figure 2-2.

Figure 2-2
Current and current protection calibration connections

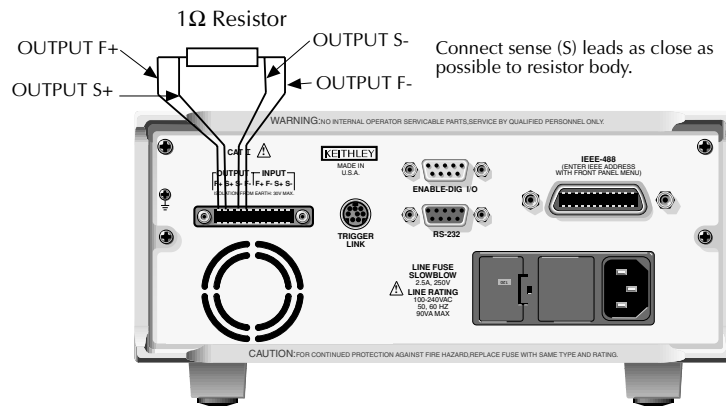

Model 2510

3. Press ENTER. The Model 2510 will display the following:
RES VALUE: 1.00000Ω
Use ◀, ▶, ▲, ▼, ENTER or EXIT.
4. Adjust the Model 2510 display to agree exactly with the characterized value of the 1Ω resistor, then press ENTER.
5. Select I-PROTECTION, then press ENTER. The instrument will then display the following:
CURRENT PROTECTION
Connect 1Ω load to Peltier. ►
◀ Then press ENTER.
6. With the 1Ω resistor still connected to the OUTPUT terminals, press ENTER. The Model 2510 will automatically complete the current protection calibration process.
7. Disconnect the 1Ω resistor from the OUTPUT terminals.

Step 4: Temperature calibration

1. Connect the 100Ω resistor to the Model 2510 INPUT terminals, as shown in Figure 2-3.
2. From the CAL EXECUTE menu, select TEMPERATURE, then press ENTER. The instrument will display the following message:
TEMPERATURE CAL
THERMISTOR RTD I-SS V-SS

Figure 2-3
Thermistor and RTD
calibration resistor
connections

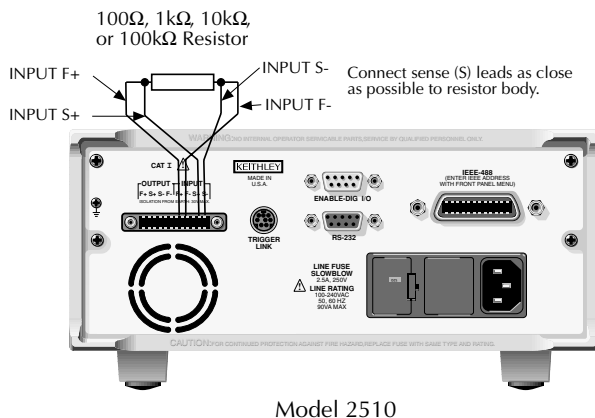

3. Select THERMISTOR, then press ENTER. The instrument will display the following:
THERMISTOR CAL
100Ω 1kΩ 10kΩ 100kΩ
4. Select 100Ω, then press ENTER. The unit will display the following:
THERMISTOR CAL
Connect 100Ω to temperature ►
◀ sensor and press ENTER.
5. Make sure the 100Ω resistor is properly connected, then press ENTER. The Model 2510 will display the following:
RES VALUE: 0.100000kΩ
Use ◀, ▶, ▲, ▼, ENTER or EXIT.
6. Use the EDIT keys to adjust the Model 2510 display to agree exactly with the characterized 100Ω resistance value, then press ENTER. The unit will display the following:
THERMISTOR CAL
Connect a Short to temperature ►
◀ sensor and press ENTER.
7. Short all four INPUT terminals together using clean copper wire, as shown in Figure 2-4. Allow one minute for thermal equilibrium.

Figure 2-4
Shorted input
calibration connections

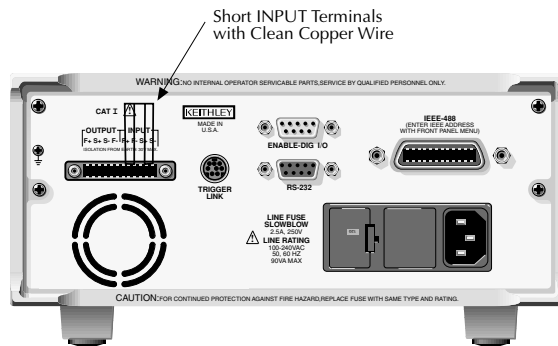

Model 2510

NOTE The characterized 1Ω resistor can be used in place of the shorted INPUT terminals, if desired. Enter the characterized value of the 1Ω resistor at the RES VALUE prompt.

8. Press ENTER. The Model 2510 will display the following:
RES VALUE: 00.00000 Ω
Use ◀, ▶, ▲, ▼, ENTER or EXIT.
9. Press ENTER to complete the shorted calibration step, then remove the shorting wires from the INPUT terminals.
10. From the THERMISTOR CAL menu, select $1k\Omega$, then press ENTER. The unit will display the following:
THERMISTOR CAL
Connect $1k\Omega$ to temperature ▶
◀ sensor and press ENTER.
11. Connect the $1k\Omega$ resistor to the Model 2510 INPUT terminals (see Figure 2-3).
12. Press ENTER. The Model 2510 will display the following:
RES VALUE: 01.00000 $k\Omega$
Use ◀, ▶, ▲, ▼, ENTER or EXIT.
13. Use the EDIT keys to adjust the Model 2510 display to agree exactly with the characterized $1k\Omega$ resistance value, then press ENTER. The unit will display the following:
THERMISTOR CAL
Connect a Short to temperature ▶
◀ sensor and press ENTER.
14. Short all four INPUT terminals together using clean copper wire (see Figure 2-4). Allow one minute for thermal equilibrium.
15. Press ENTER. The Model 2510 will display the following:
RES VALUE: 00.00000 Ω
Use ◀, ▶, ▲, ▼, ENTER or EXIT.
16. Press ENTER to complete the shorted calibration step, then remove the shorting wires from the INPUT terminals.

17. From the THERMISTOR CAL menu, select 10k Ω , then press ENTER. The unit will display the following:
THERMISTOR CAL
Connect 10k Ω to temperature ►
◀ sensor and press ENTER.
18. Connect the 10k Ω resistor to the Model 2510 INPUT terminals (Figure 2-3).
19. Press ENTER. The Model 2510 will display the following:
RES VALUE: 010.0000k Ω
Use ◀, ▶, ▲, ▼, ENTER or EXIT.
20. Use the EDIT keys to adjust the Model 2510 display to agree exactly with the characterized 10k Ω resistance value, then press ENTER. The unit will display the following:
THERMISTOR CAL
Connect a Short to temperature ►
◀ sensor and press ENTER.
21. Short all four INPUT terminals together using clean copper wire (see Figure 2-4). Allow one minute for thermal equilibrium.
22. Press ENTER. The Model 2510 will display the following:
RES VALUE: 00.00000 Ω
Use ◀, ▶, ▲, ▼, ENTER or EXIT.
23. Press ENTER to complete the shorted calibration step, then remove the shorting wires from the INPUT terminals.
24. From the THERMISTOR CAL menu, select 100k Ω , then press ENTER. The unit will display the following:
THERMISTOR CAL
Connect 100k Ω to temperature ►
◀ sensor and press ENTER.
25. Connect the 100k Ω resistor to the Model 2510 INPUT terminals (Figure 2-3).
26. Press ENTER. The Model 2510 will display the following:
RES VALUE: 0100.000k Ω
Use ◀, ▶, ▲, ▼, ENTER or EXIT.
27. Use the EDIT keys to adjust the Model 2510 display to agree exactly with the characterized 100k Ω resistance value, then press ENTER. The unit will display the following:
THERMISTOR CAL
Connect a Short to temperature ►
◀ sensor and press ENTER.
28. Short all four INPUT terminals together using clean copper wire (see Figure 2-4). Allow one minute for thermal equilibrium.
29. Press ENTER. The Model 2510 will display the following:
RES VALUE: 00.00000 Ω
Use ◀, ▶, ▲, ▼, ENTER or EXIT.

30. Press ENTER to complete the shorted calibration step, then remove the shorting wires from the INPUT terminals.
31. Press EXIT to return to the TEMPERATURE CAL menu.
32. Select RTD, then press ENTER. The unit displays the following:
RTD CAL
Connect 100 Ω to temperature ►
◀ sensor and press ENTER.
33. Connect the 100 Ω resistor to the Model 2510 INPUT terminals (Figure 2-3).
34. Press ENTER. The Model 2510 will display the following:
RES VALUE: 0.100000k Ω
Use ◀, ▶, ▲, ▼, ENTER or EXIT.
35. Adjust the display to agree with the value of the 100 Ω resistor, then press ENTER. The unit will display the following:
RTD CAL
Connect a Short to temperature ►
◀ sensor and press ENTER.
36. Short all four INPUT terminals together using clean copper wire (see Figure 2-4). Allow one minute for thermal equilibrium.
37. Press ENTER. The Model 2510 will display the following:
RES VALUE: 00.00000 Ω
Use ◀, ▶, ▲, ▼, ENTER or EXIT.
38. Press ENTER to complete the shorted calibration step, then remove the shorting wires from the INPUT terminals.
39. Connect the 1k Ω resistor to the Model 2510 INPUT terminals (Figure 2-3).
40. Press ENTER. The Model 2510 will display the following:
RES VALUE: 01.00000k Ω
Use ◀, ▶, ▲, ▼, ENTER or EXIT.
41. Adjust the display to agree with the value of the 1k Ω resistor, then press ENTER. The unit will display the following:
RTD CAL
Connect a Short to temperature ►
◀ sensor and press ENTER.
42. Short all four INPUT terminals together using clean copper wire (see Figure 2-4). Allow one minute for thermal equilibrium.
43. Press ENTER. The Model 2510 will display the following:
RES VALUE: 00.00000 Ω
Use ◀, ▶, ▲, ▼, ENTER or EXIT.

44. Press ENTER to complete the shorted calibration step, then remove the shorting wires from the INPUT terminals.
45. From the TEMPERATURE CAL menu, select I-SS, then press ENTER. The unit displays the following:
I-SS CAL
Connect 1k Ω to temperature ►
◀ sensor and press ENTER.
46. Connect the DMM and 1k Ω resistor to the Model 2510 (Figure 2-5). Press ENTER. The Model 2510 will display the following:
RES VALUE: 01.00000k Ω
Use ◀, ▶, ▲, ▼, ENTER or EXIT.
47. Use the EDIT keys to adjust the Model 2510 display to agree exactly with the characterized 1k Ω resistance value, then press ENTER. The unit will prompt for the DMM voltage reading:
DMM RDG: +0.833330 V
Use ◀, ▶, ▲, ▼, ENTER or EXIT.
48. Note the DMM reading, then adjust the Model 2510 display to agree with that value. Press ENTER.
49. From the TEMPERATURE CAL menu, select V-SS, then press ENTER. The unit displays the following:
V-SS CAL
Connect 1k Ω to temperature ►
◀ sensor and press ENTER.
50. Make sure the 1k Ω resistor and the DMM are still connected to the Model 2510 INPUT terminals (Figure 2-5).
51. Press ENTER. The Model 2510 will display the following:
DMM RDG: +2.500000V
Use ◀, ▶, ▲, ▼, ENTER or EXIT.
52. Note the DMM reading, use the EDIT keys to adjust the Model 2510 display to agree exactly with that value, then press ENTER. The unit will display the following:
V-SS CAL
Connect a Short to temperature ►
◀ sensor and press ENTER.
53. Short all four INPUT terminals together using clean copper wire (see Figure 2-4). Allow one minute for thermal equilibrium.
54. Press ENTER. The Model 2510 will display the following:
DMM RDG: +0.000000V
Use ◀, ▶, ▲, ▼, ENTER or EXIT.

55. Press ENTER to complete the shorted calibration step, then remove the shorting wires from the INPUT terminals.
56. Press EXIT to return to the CAL EXECUTE menu.

Figure 2-5
I-SS and V-SS calibration
resistor connections

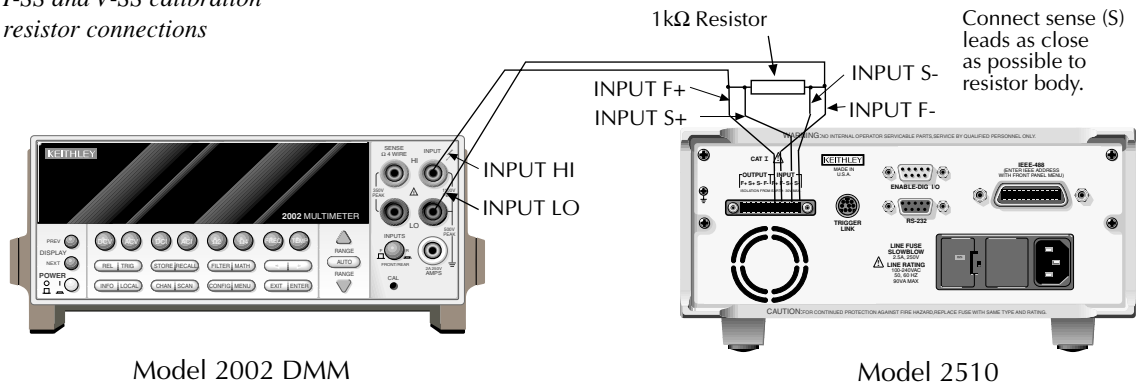

Step 5: AC ohms calibration

- From the CAL EXECUTE menu, select AC-OHMS, then press ENTER. The instrument will display the following message:
AC-OHMS CAL
Connect a 100Ω load to Peltier. ►
◀ Then press ENTER.
- Connect the 100Ω resistor to the OUTPUT terminals (see Figure 2-6).
- Press ENTER. The instrument will display the following:
RES VALUE: 0.100000kΩ
Use ◀, ▶, ▲, ▼, ENTER or EXIT.
- Use the EDIT keys to adjust the Model 2510 display to agree exactly with the characterized 100Ω resistance value, then press ENTER.

Figure 2-6
AC ohms calibration
connections

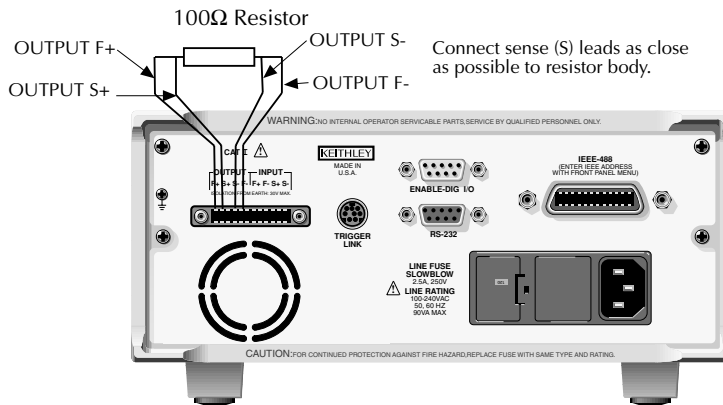

Model 2510

Step 6: Voltage source calibration

- From the CAL EXECUTE menu, select V-SOURCE, then press ENTER. The instrument will display the following message:
V-SRC CAL
Open Peltier leads then press ►
◀ ENTER.
- Disconnect all resistors and test leads from the Model 2510 OUTPUT terminals.
- Press ENTER to complete voltage source calibration.
- Press EXIT to return to the CALIBRATION menu.

Step 7: Enter calibration dates and save calibration

NOTE For temporary calibration without saving new calibration constants, proceed to Step 8: Lock out calibration.

1. From the CALIBRATION menu, select SAVE, then press ENTER. The unit will prompt you for the calibration date:
CAL DATE: 02/15/2000
Use ◀, ▶, ▲, ▼, ENTER or EXIT.
2. Using the EDIT keys, change the displayed date to today's date, then press the ENTER key. Press ENTER again to confirm the date.
3. The unit will then prompt for the calibration due date:
NEXT CAL: 02/15/2001
Use ◀, ▶, ▲, ▼, ENTER or EXIT.
4. Set the calibration due date to the desired value, then press ENTER. Press ENTER again to confirm the date.
5. Once the calibration dates are entered, calibration is complete, and the following message will be displayed:
CALIBRATION COMPLETE
Press ENTER to save; EXIT to abort
6. Press ENTER to save the calibration data (or press EXIT to abort without saving calibration data).

Step 8: Lock out calibration

From the CAL EXECUTE menu, select LOCK, then press ENTER to lock out calibration. Press EXIT to return to normal display.

Remote calibration

Use the following procedure to perform remote calibration by sending SCPI commands over the IEEE-488 bus or RS-232 port. The remote commands and appropriate parameters are separately summarized for each step.

Remote calibration command summary

Table 2-5 summarizes remote calibration commands used in this section.

NOTE For a detailed description of all calibration commands and queries, refer to Appendix B.

Table 2-5
Remote calibration command summary

Command	Description
:CALibration	Calibration subsystem.
:PROTeCted	Calibration commands protected by code/password.
:CODE '<password>'	Unlock calibration. (Default code/password: KI002510.)
:SENSe	
:VOLTage <NRf>	Calibrate Peltier voltage measurement.
:CURRent <NRf>	Calibrate current measurement.
:TEMPerature <NRf>	Calibrate temperature measurement.
:SOURce <NRf>	Calibrate Peltier source/sense voltage.
:AUTO	Calibrate voltage source.
:IPDac	Calibrate current protection DAC.
:RESistance	
[:AC] <NRf>	Calibrate AC ohms.
:DATE <y>,<m>,<d>	Program calibration year, month, day.
:NDUE <y>,<m>,<d>	Program calibration due year, month, day.
:SAVE	Save calibration data in EEPROM.
:LOCK	Lock out calibration.

Remote calibration procedure

Step 1: Prepare the Model 2510 for calibration

1. With the power off, connect the Model 2510 to the controller IEEE-488 interface or RS-232 port using a shielded interface cable.
2. Turn on the Model 2510 and the test equipment, and allow them to warm up for at least one hour before performing calibration.
3. If you are using the IEEE-488 interface, make sure the primary address of the Model 2510 is the same as the address specified in the program you will be using to send commands. (Use the MENU key and the COMMUNICATION menu to access the IEEE-488 address.)
4. Send the following command to unlock calibration:
:CAL:PROT:CODE 'K1002510'
5. Table 2-6 summarizes the various calibration steps and associated commands, which are covered in more detail throughout the procedure.

Table 2-6

Remote calibration step summary

Calibrated function	Calibration command	Test connections
Voltage	:OUTP ON :SOUR:VOLT 8.5 :CAL:PROT:SENS:VOLT <DMM_Reading> :CAL:PROT:SOUR <DMM_Reading> :SOUR:VOLT 0 :CAL:PROT:SENS:VOLT <DMM_Reading> :CAL:PROT:SOUR <DMM_Reading> :SOUR:VOLT -8.5 :CAL:PROT:SENS:VOLT <DMM_Reading> :CAL:PROT:SOUR <DMM_Reading> :OUTP OFF	DMM to OUTPUT (Figure 2-1) DMM to OUTPUT (Figure 2-1) DMM to OUTPUT (Figure 2-1) DMM to OUTPUT (Figure 2-1) DMM to OUTPUT (Figure 2-1) DMM to OUTPUT (Figure 2-1)
Current	:OUTP ON :CAL:PROT:SENS:CURR <Resistance_Value>	1Ω to OUTPUT (Figure 2-2)
Current protection	:CAL:PROT:IPD :OUTP OFF	1Ω to OUTPUT (Figure 2-2)

Table 2-6 (cont.)

Remote calibration step summary

Calibrated function	Calibration command	Test connections
Temperature Thermistor sensor	:SYST:RSEN ON :SENS:TEMP:TRAN THER :SENS:TEMP:THER:RANG 100 :CAL:PROT:TEMP <Resistance_Value> :CAL:PROT:TEMP 0 :SENS:TEMP:THER:RANG 1e3 :CAL:PROT:TEMP <Resistance_Value> :CAL:PROT:TEMP 0 :SENS:TEMP:THER:RANG 1e4 :CAL:PROT:TEMP <Resistance_Value> :CAL:PROT:TEMP 0 :SENS:TEMP:THER:RANG 1e5 :CAL:PROT:TEMP <Resistance_Value> :CAL:PROT:TEMP 0	100Ω to INPUT (Figure 2-3) Short to INPUT (Figure 2-4) 1kΩ to INPUT (Figure 2-3) Short to INPUT (Figure 2-4) 10kΩ to INPUT (Figure 2-3) Short to INPUT (Figure 2-4) 100kΩ to INPUT (Figure 2-3) Short to INPUT (Figure 2-4)
RTD sensor	:SENS:TEMP:TRAN RTD :SENS:TEMP:RTD:RANG 100 :CAL:PROT:TEMP <Resistance_Value> :CAL:PROT:TEMP 0 :SENS:TEMP:RTD:RANG 1000 :CAL:PROT:TEMP <Resistance_Value> :CAL:PROT:TEMP 0	100Ω to INPUT (Figure 2-3) Short to INPUT (Figure 2-4) 1000Ω to INPUT (Figure 2-3) Short to INPUT (Figure 2-4)
Current sensor	:SENS:TEMP:TRAN ISS :CAL:PROT:TEMP <Resistance_Value> :CAL:PROT:TEMP <DMM_Reading>	1kΩ/DMM to INPUT (Figure 2-5)
Voltage sensor	:SENS:TEMP:TRAN VSS :CAL:PROT:TEMP <DMM_Reading> :CAL:PROT:TEMP 0	1kΩ/DMM to INPUT (Figure 2-5) Short to INPUT (Figure 2-4)
AC ohms	:CAL:PROT:RES <Resistance_Value>	100Ω to OUTPUT (Figure 2-6)
Voltage source	:OUTP ON :CAL:PROT:SOUR:AUTO :OUTP OFF	None (open OUTPUT)

Step 2: Voltage calibration

1. Connect the DMM to the Model 2510 OUTPUT terminals, as shown in Figure 2-1.
2. Select the DMM DC voltage function, and enable auto-range.
3. Send this command to turn on the output:
:OUTP ON
4. Send the following command to output +8.5V:
:SOUR:VOLT 8.5
5. Note and record the DMM reading, and then send that value as the parameter for the following commands:
:CAL:PROT:SENS:VOLT <DMM_Reading>
:CAL:PROT:SOUR <DMM_Reading>
For example, if the DMM reading is 8.51V, the correct commands are:
:CAL:PROT:SENS:VOLT 8.51
:CAL:PROT:SOUR 8.51
6. Send the following command to output 0V:
:SOUR:VOLT 0
7. Note and record the DMM reading, then send that value as the parameter for the following commands:
:CAL:PROT:SENS:VOLT <DMM_Reading>
:CAL:PROT:SOUR <DMM_Reading>
8. Send the following command to output -8.5V:
:SOUR:VOLT -8.5
9. Note and record the DMM reading, then send that value as the parameter for the following commands:
:CAL:PROT:SENS:VOLT <DMM_Reading>
:CAL:PROT:SOUR <DMM_Reading>
10. Send this command to turn off the output:
:OUTP OFF
11. Disconnect the DMM from the OUTPUT terminals.

Step 3: Current and current protection calibration

1. Connect the 1 Ω resistor to the Model 2510 OUTPUT terminals, as shown in Figure 2-2.
2. Send this command to turn on the output:
:OUTP ON
3. Send the following command with the characterized 1 Ω resistor value as the command parameter:
:CAL:PROT:SENS:CURR <Resistance_Value>
For example, if the actual resistor value is 1.01 Ω , the correct command is:
:CAL:PROT:SENS:CURR 1.01

4. With the 1Ω resistor still connected, send the following command to calibrate the current protection DAC:
:CAL:PROT:IPD
5. Send this command to turn off the output:
:OUTP OFF
6. Disconnect the 1Ω resistor from the OUTPUT terminals.

Step 4: Temperature calibration

1. Connect the 100Ω resistor to the Model 2510 INPUT terminals, as shown in Figure 2-3.
2. Send the following command to select the thermistor type temperature sensor:
:SENS:TEMP:TRAN THER
3. Send the following command to enable 4-wire sensing:
:SYST:RSEN ON
4. Send this command to select the 100Ω resistance range:
:SENS:TEMP:THER:RANG 100
5. Send the following command with the characterized 100Ω resistance value as the parameter to calibrate the 100Ω range:
:CAL:PROT:SENS:TEMP <Resistance_Value>
6. Short the INPUT terminals with clean copper wire (Figure 2-4). Allow one minute for thermal equilibrium, then send this command:
:CAL:PROT:SENS:TEMP 0
7. Connect the $1k\Omega$ resistor to the Model 2510 INPUT terminals (Figure 2-3).
8. Send this command to select the $1k\Omega$ resistance range:
:SENS:TEMP:THER:RANG 1e3
9. Send the following command with the characterized $1k\Omega$ resistance value as the parameter to calibrate the $1k\Omega$ range:
:CAL:PROT:SENS:TEMP <Resistance_Value>
10. Short the INPUT terminals with clean copper wire (Figure 2-4). Allow one minute for thermal equilibrium, then send this command:
:CAL:PROT:SENS:TEMP 0
11. Connect the $10k\Omega$ resistor to the Model 2510 INPUT terminals (Figure 2-3).
12. Send this command to select the $10k\Omega$ resistance range:
:SENS:TEMP:THER:RANG 1e4
13. Send the following command with the characterized $10k\Omega$ resistance value as the parameter to calibrate the $10k\Omega$ range:
:CAL:PROT:SENS:TEMP <Resistance_Value>
14. Short the INPUT terminals with clean copper wire (Figure 2-4). Allow one minute for thermal equilibrium, then send this command:
:CAL:PROT:SENS:TEMP 0
15. Connect the $100k\Omega$ resistor to the Model 2510 INPUT terminals (Figure 2-3).

16. Send this command to select the 100k Ω resistance range:
:SENS:TEMP:THER:RANG 1e5
17. Send the following command with the characterized 100k Ω resistance value as the parameter to calibrate the 100k Ω range:
:CAL:PROT:SENS:TEMP <Resistance_Value>
18. Short the INPUT terminals with clean copper wire (Figure 2-4). Allow one minute for thermal equilibrium, then send this command:
:CAL:PROT:SENS:TEMP 0
19. Connect the 100 Ω resistor to the INPUT terminals (Figure 2-3).
20. Send the following command to select the RTD type temperature sensor:
:SENS:TEMP:TRAN RTD
21. Send this command to select the 100 Ω range:
:SENS:TEMP:RTD 100
22. Send the following command with the characterized 100 Ω resistance value as the parameter to calibrate the RTD measurement function:
:CAL:PROT:SENS:TEMP <Resistance_Value>
23. Short the INPUT terminals with clean copper wire (Figure 2-4). Allow one minute for thermal equilibrium, then send this command:
:CAL:PROT:SENS:TEMP 0
24. Connect the 1000 Ω resistor to the INPUT terminals (Figure 2-5).
25. Send this command to select the 1000 Ω range:
:SENS:TEMP:RTD:RANG 1000
26. Send the following command with the characterized 1000 Ω resistance value as the parameter to calibrate the RTD measurement function:
:CAL:PROT:SENS:TEMP <Resistance_Value>
27. Short the INPUT terminals with clean copper wire (Figure 2-4). Allow one minute for thermal equilibrium, then send this command:
:CAL:PROT:SENS:TEMP 0
28. Connect the DMM and the 1k Ω resistor to the INPUT terminals (Figure 2-5).
29. Send the following command to select a solid-state, current-type temperature sensor:
:SENS:TEMP:TRAN ISS
30. Send the following command with the characterized 1k Ω resistance value as the parameter:
:CAL:PROT:SENS:TEMP <Resistance_Value>
31. Note the DMM reading, then send that value as the parameter for the following command:
:CAL:PROT:SENS:TEMP <DMM_Reading>
32. Make sure the 1k Ω resistor and DMM are still connected to the Model 2510 INPUT terminals (Figure 2-5).
33. Send the following command to select a solid-state, voltage-type temperature sensor:
:SENS:TEMP:TRAN VSS

34. Note the DMM reading, then send the following command with the DMM reading value as the parameter to calibrate the current type solid-state sensor:
:CAL:PROT:SENS:TEMP <DMM_Reading>
35. Short the INPUT terminals with clean copper wire (Figure 2-4). Allow one minute for thermal equilibrium, then send this command:
:CAL:PROT:SENS:TEMP 0

Step 5: AC ohms calibration

1. Connect the 100 Ω resistor to the OUTPUT terminals (see Figure 2-6). Note that the output will be turned off for the AC ohms calibration step.
2. Send the following command with the characterized 100 Ω resistance value as the command parameter to calibrate the AC ohms function:
:CAL:PROT:RES <Resistance_Value>

Step 6: Voltage source calibration

1. Disconnect all resistors and test leads from the Model 2510 OUTPUT terminals.
2. Turn on the output by sending:
:OUTP ON
3. Send this command to complete voltage source calibration:
:CAL:PROT:SOUR:AUTO
4. Turn off the output by sending:
:OUTP OFF

Step 7: Program calibration dates

Use following commands to set the calibration date and calibration due date:

```
:CAL:PROT:DATE <yyyy>, <mm>, <dd>      (Calibration date)
:CAL:PROT:NDUE <yyyy>, <mm>, <dd>     (Next calibration due date)
```

Note that the year, month, and date must be separated by commas.

Step 8: Save calibration constants

Calibration is now complete, so you can store the calibration constants in EEROM by sending the following command:

```
:CAL:PROT:SAVE
```

NOTE Calibration will be temporary unless you send the SAVE command.

Step 9: Lock out calibration

To lock out further calibration, send the following command after completing the calibration procedure:

```
:CAL:PROT:LOCK
```

3

Routine Maintenance

Introduction

The information in this section deals with routine type maintenance that can be performed by the operator.

Line fuse replacement

WARNING Disconnect the line cord at the rear panel, and remove all test leads connected to the instrument (front and rear) before replacing the line fuse.

The power line fuse is accessible from the rear panel and is integral with the AC power module (see Figure 3-1).

Figure 3-1
Rear panel

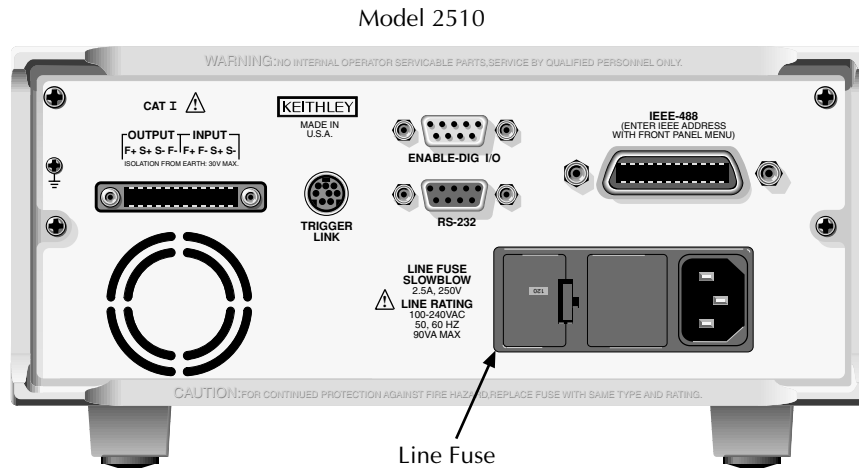

Perform the following steps to replace the line fuse:

1. Using a small flat-blade screwdriver, carefully release the locking tab that secures the fuse carrier to the power module.
2. Pull out the fuse carrier, and replace the fuse with the type specified in Table 3-1.

CAUTION To prevent instrument damage, use only the fuse type specified in Table 3-1.

3. Reinstall the fuse carrier, pushing it in firmly until it locks into place.

NOTE If the power line fuse continues to blow, a circuit malfunction exists and must be corrected. Refer to the troubleshooting information in Section 4 of this manual for additional information.

Table 3-1
Power line fuse

Line voltage	Rating	Keithley part no.
100-240V	250V, 2.5A, Slow Blow 5 × 20mm	FU-106-2.5

4 Troubleshooting

Introduction

This section of the manual will assist you in troubleshooting and repairing the Model 2510. Included are self-tests, test procedures, troubleshooting tables, and circuit descriptions. Note that disassembly instructions are located in Section 5, and component layout drawings are at the end of Section 6.

Safety considerations

WARNING The information in this section is intended for qualified service personnel only. Do not perform these procedures unless you are qualified to do so. Some of these procedures may expose you to hazardous voltages that could cause personal injury or death. Use caution when working with hazardous voltages.

Repair considerations

Before making any repairs to the Model 2510, be sure to read the following considerations.

CAUTION The PC boards are built using surface mount techniques and require specialized equipment and skills for repair. If you are not equipped and/or qualified, it is strongly recommended that you send the unit back to the factory for repairs or limit repairs to the PC board replacement level. Without proper equipment and training, you could damage a PC board beyond repair.

- Repairs will require various degrees of disassembly; however, it is recommended that the Front Panel Tests be performed prior to any disassembly. The disassembly instructions for the Model 2510 are contained in Section 5 of this manual.
- Do not make repairs to surface mount PC boards unless equipped and qualified to do so (see previous CAUTION).
- When working inside the unit and replacing parts, be sure to adhere to the handling precautions and cleaning procedures explained in Section 5.
- Many CMOS devices are installed in the Model 2510. These static-sensitive devices require special handling as explained in Section 5.
- Whenever a circuit board is removed or a component is replaced, the Model 2510 must be recalibrated. See Section 2 for details on calibrating the unit.

Power-on self-test

During the power-on sequence, the Model 2510 will perform a checksum test on its EPROM and test its RAM. If one of these tests fails, the instrument will lock up.

Front panel tests

There are three front panel tests: one to test the functionality of the front panel keys and two to test the display. In the event of a test failure, refer to Display board checks for details on troubleshooting the display board.

KEYS test

The KEYS test lets you check the functionality of each front panel key. Perform the following steps to run the KEYS test.

1. Display the MAIN MENU by pressing the MENU key.
2. Using the EDIT keys, select TEST, and press ENTER to display the SELF-TEST MENU.
3. Select DISPLAY-TESTS, and press ENTER to display the following menu:
FRONT PANEL TESTS
KEYS DISPLAY-PATTERNS CHAR-SET
4. Select KEYS, and press ENTER to start the test. When a key is pressed, the label name for that key will be displayed to indicate that it is functioning properly. When the key is released, the message “No keys pressed” is displayed.
5. Pressing EXIT tests the EXIT key. However, the second consecutive press of EXIT aborts the test and returns the instrument to the SELF-TEST MENU. Continue pressing EXIT to back out of the menu structure.

DISPLAY PATTERNS test

The display test lets you verify that each pixel and annunciator in the vacuum fluorescent display is working properly. Perform the following steps to run the display test:

1. Display the MAIN MENU by pressing the MENU key.
2. Select TEST, and press ENTER to display the SELF-TEST MENU.
3. Select DISPLAY-TESTS, and press ENTER to display the following menu:
FRONT PANEL TESTS
KEYS DISPLAY-PATTERNS CHAR-SET
4. Select DISPLAY-PATTERNS, and press ENTER to start the display test. There are five parts to the display test. Each time a front panel key (except EXIT) is pressed, the next part of the test sequence is selected. The five parts of the test sequence are as follows:
 - Checkerboard pattern (alternate pixels on) and all annunciators.
 - Checkerboard pattern and the annunciators that are on during normal operation.
 - Horizontal lines (pixels) of the first digit are sequenced.
 - Vertical lines (pixels) of the first digit are sequenced.
 - Each digit (and adjacent annunciator) is sequenced. All the pixels of the selected digit are on.
5. When finished, abort the display test by pressing EXIT. The instrument returns to the FRONT PANEL TESTS MENU. Continue pressing EXIT to back out of the menu structure.

CHAR SET test

The character set test lets you display all characters. Perform the following steps to run the character set test:

1. Display the MAIN MENU by pressing the MENU key.
2. Select TEST, and press ENTER to display the SELF-TEST MENU.
3. Select DISPLAY-TESTS, and press ENTER to display the following menu:
FRONT PANEL TESTS
KEYS DISPLAY-PATTERNS CHAR-SET
4. Select CHAR-SET, and press ENTER to start the character set test. Press any key except EXIT to cycle through all displayable characters.
5. When finished, abort the character set test by pressing EXIT. The instrument returns to the FRONT PANEL TESTS MENU. Continue pressing EXIT to back out of the menu structure.

Principles of operation

The following information is provided to support the troubleshooting tests and procedures covered in this section of the manual.

Overall block diagram

Figure 4-1 shows an overall block diagram of the Model 2510. Circuitry may be divided into three general areas:

- **Analog circuits** — includes source circuits such as the pulse-width modulator, H-drive, and class D output stages, as well as measurement circuits such as the sensor signal conditioning and A/D converter circuits.
- **Digital circuits** — includes the microcomputer that controls the analog section, front panel, and GPIB and RS-232 ports, as well as associated interfacing circuits.
- **Power supplies** — converts the AC line voltage into DC voltages that supply the power for the digital and analog circuits, and the class D power amplifier.

Figure 4-1
Overall block diagram

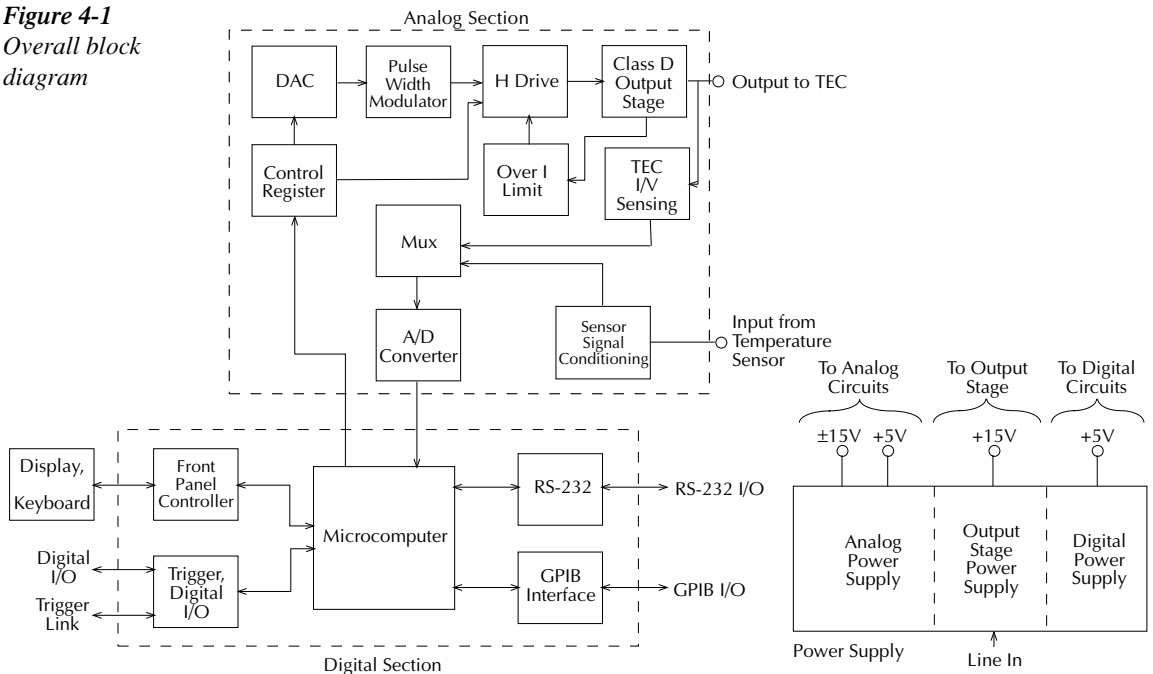

Analog circuits

Figure 4-2 shows a block diagram of the analog circuits. These circuits are discussed in more detail in the following paragraphs.

Figure 4-2
Block diagram of
analog circuits

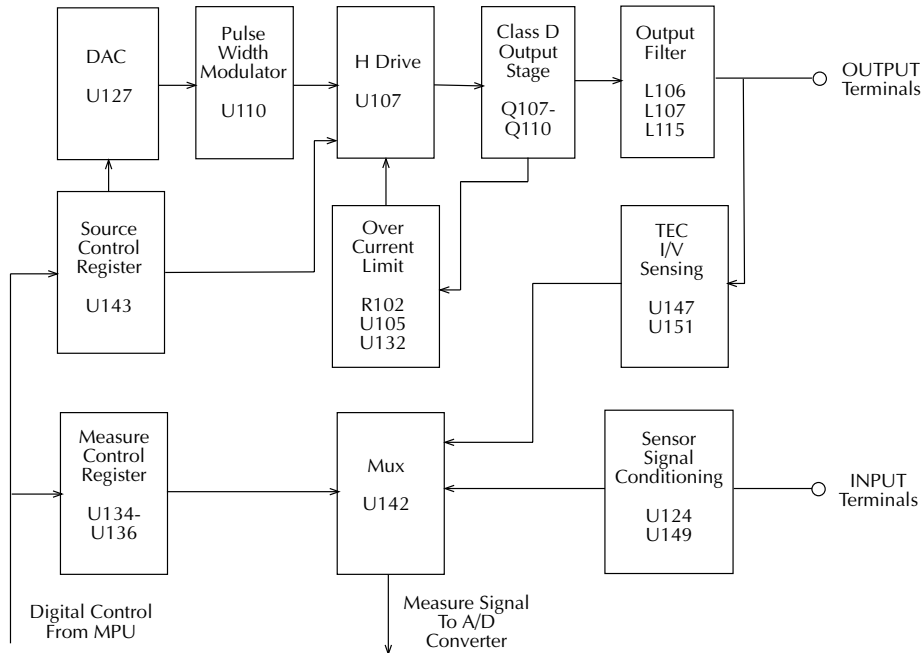

Source circuits

The Model 2510 source is a digitally controlled, class D power amplifier with the output stage in an H-bridge configuration. U127 is a 16-bit DAC that controls the pulse-width modulator U110. The H-drive IC, U107, switches the four output FETs, Q107 - Q110. Output filtering is provided by L106, L107, L115, and associated components. Control information for the DAC and H-drive circuit is fed through serial-to-parallel converter U143.

The source amplitude voltage is controlled by varying the duty cycle of the pulse-width modulator and, ultimately, the output stage with the digital control information fed to the DAC and the serial-to-parallel converter. For example, with a duty cycle of 50%, the output is 2.5V.

The hardware current limit circuit consists of R102, U105, U132, and associated components. The output stage current that flows through R102 develops a voltage that is amplified by U105 and compared with a programmed current limit in 10-bit DAC U132. If the current value exceeds the pre-programmed limit, the H-drive IC is disabled, turning off the output stage.

Class D Amplifier

Figure 4-3 shows a simplified schematic of the class D amplifier output stage. The H_DAC converts control information from the processor into an analog signal that controls the pulse-width modulator (PWM) through the H-bridge control. The IP_DAC converts current limit control information from the processor and forms the BRIDGE OFF signal that turns off the output stage in an over-current condition.

Figure 4-3
Simplified schematic
of class D amplifier

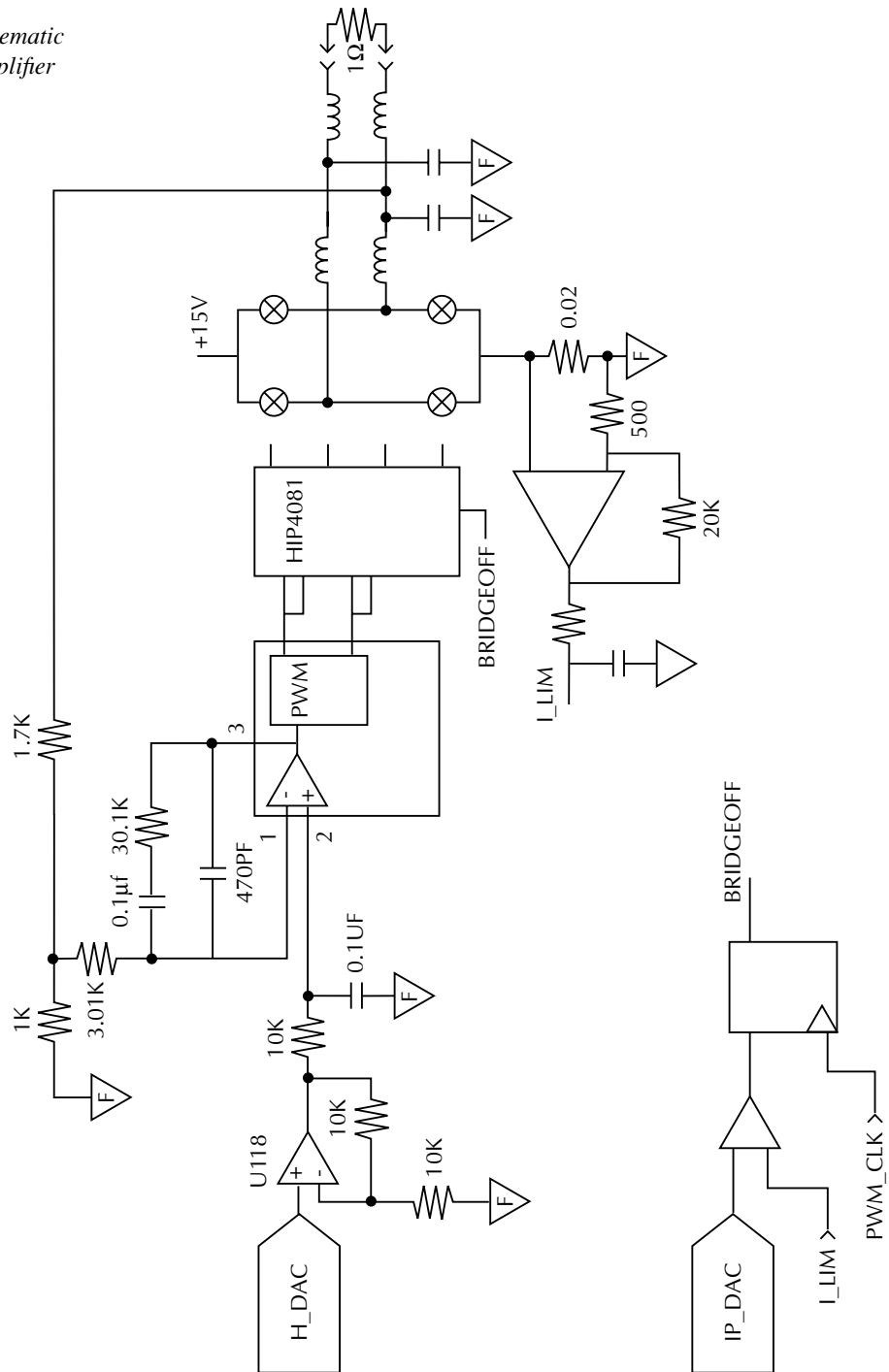

H-bridge

Figure 4-4 shows a simplified schematic of the H-bridge output stage switching as well as the pulse-width modulator waveforms. The four output stage transistors function as simple switches with the switching phases and duty cycles controlled by the pulse-width modulator as shown.

Figure 4-4
Simplified schematic of
H-bridge output stage

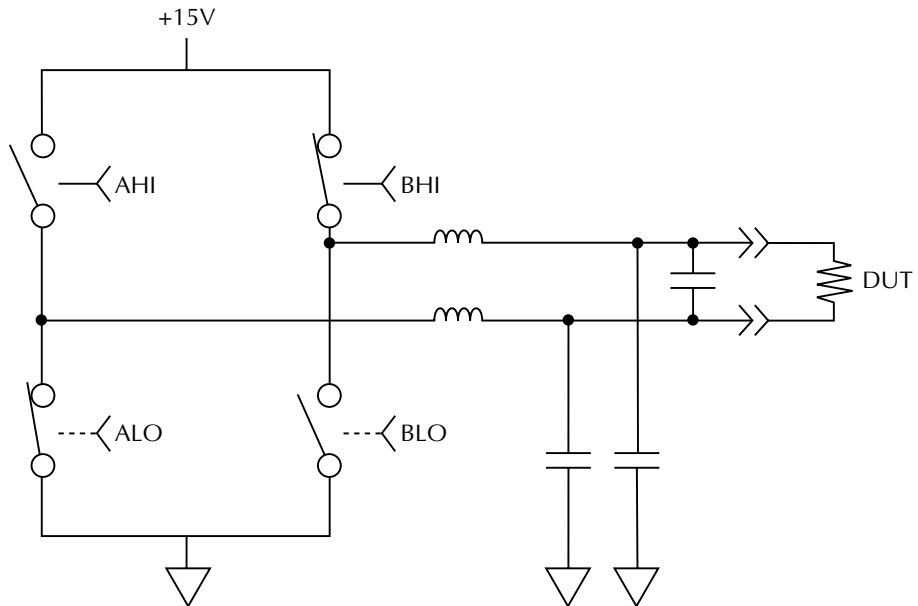

A. H-Bridge Switching

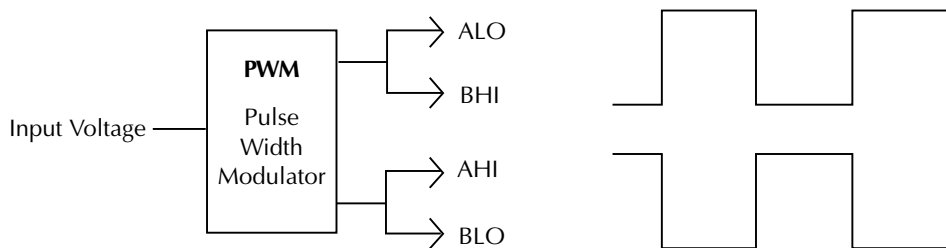

B. Pulse-Width Modulator Waveforms

Figure 4-5 shows alternate switching phases of the H-bridge output stage as well as a simplified schematic of the step-down “buck” regulator. Note that the bridge switches between alternate configurations as shown, with the duration and duty cycles controlled by the pulse-width modulator. The step-down “buck” regulator smooths the H-bridge switching waveform into a constant DC level.

Figure 4-5
H-bridge switching and
step-down regulator

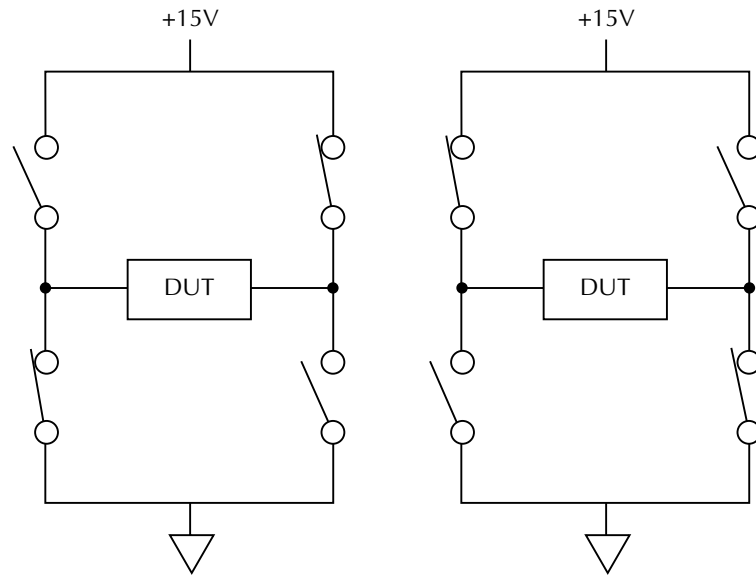

A. H-Bridge

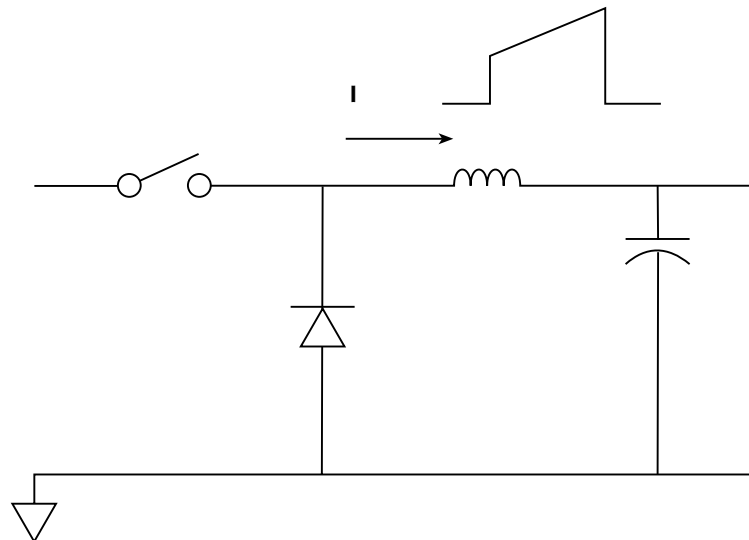

B. Step-Down “Buck” Regulator

Measurement circuits

Signal conditioning for the external temperature sensor is provided by U124, U149, and associated components. Voltage and current feedback signals from the TEC output terminals are developed by U147 and U151.

The conditioned temperature sensor, voltage, and current, feedback signals are fed to the multiplexer IC, U142, that switches among the signals during the various phases of the measurement cycle. The output of the mux is fed to the A/D converter for conversion to digital data. Additional signals switched by the mux during the measurement cycle include a reference voltage, reference temperature, internal circuit board temperature signal, and an internal +15V measurement.

Sensor conditioning

Figure 4-6 shows a simplified schematic of the sensor conditioning circuits. In this example, measurement using a $10\text{k}\Omega$ thermistor is assumed. Sensor conditioning for other thermistor ranges and sensor types is similar.

Figure 4-6
Sensor conditioning
for $10\text{k}\Omega$ thermistor

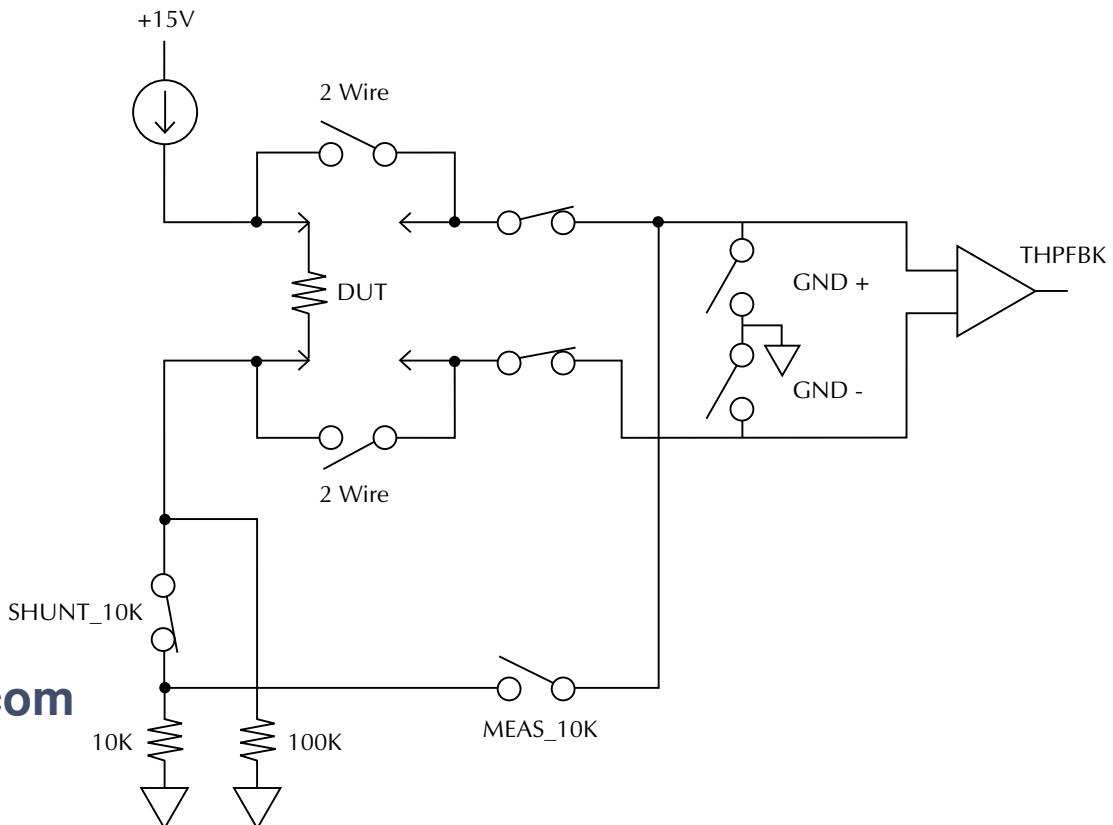

A constant current is forced through the DUT (thermistor) as well as a reference resistor (in this example, $10\text{k}\Omega$ for the $10\text{k}\Omega$ range). As various phases of the measurement cycle, the voltages across the DUT and $10\text{k}\Omega$ reference resistor are measured, and the actual DUT resistance is computed from the ratio of the two voltages. Since the resistance of the $10\text{k}\Omega$ reference resistance is accurately known (as determined during instrument calibration), the DUT resistance and a given temperature can be accurately determined, and internal software converts the resistance into an equivalent temperature reading.

A/D converter

The Model 2510 unit uses a multi-slope charge balance A/D converter with a single-slope run-down. The converter is controlled by a gate array. Commands are issued by the MPU to the gate array, and the gate array IC sends A/D reading data back to the MPU for calibration and processing.

PID hardware loop control

Figure 4-7 shows an overall diagram of the hardware aspects of the PID control loop.

Figure 4-7
PID hardware control loop

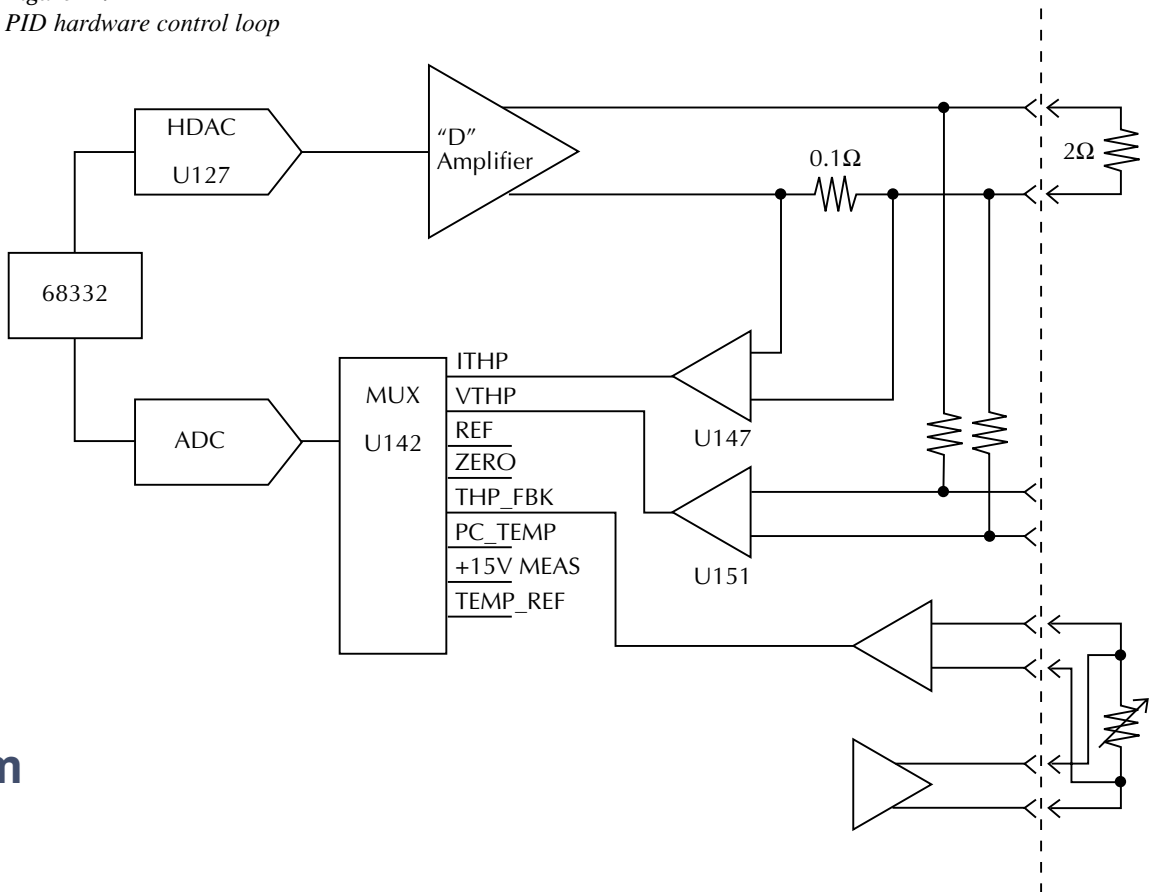

As previously discussed, source control information from the 68332 processor is fed to the HDAC where it is converted into an analog signal to control the class D amplifier output.

Power supply

Figure 4-8 shows a block diagram of the Model 2510 power supply system.

Figure 4-8
Power supply
block diagram

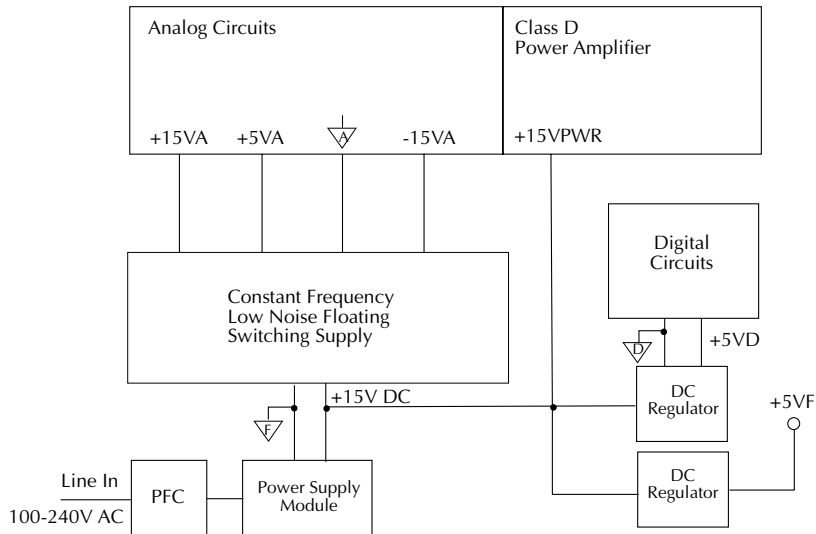

The integrated switching power supply module provides all power for the instrument while providing universal inputs and power factor correction for the 120/240V line. The +15VPWR voltage from the module powers the output stage directly, and this supply voltage is further regulated to develop a +5VF (floating) supply voltage and the +5VD (digital) voltage that powers the digital circuits.

A constant-frequency switching supply also runs off the +15V power module supply and generates the supply voltages for the analog circuits: +5VA and $\pm 15VA$.

Digital circuitry

Refer to Figure 4-9 for the following discussion on digital circuitry.

Figure 4-9
Digital circuitry
overall block diagram

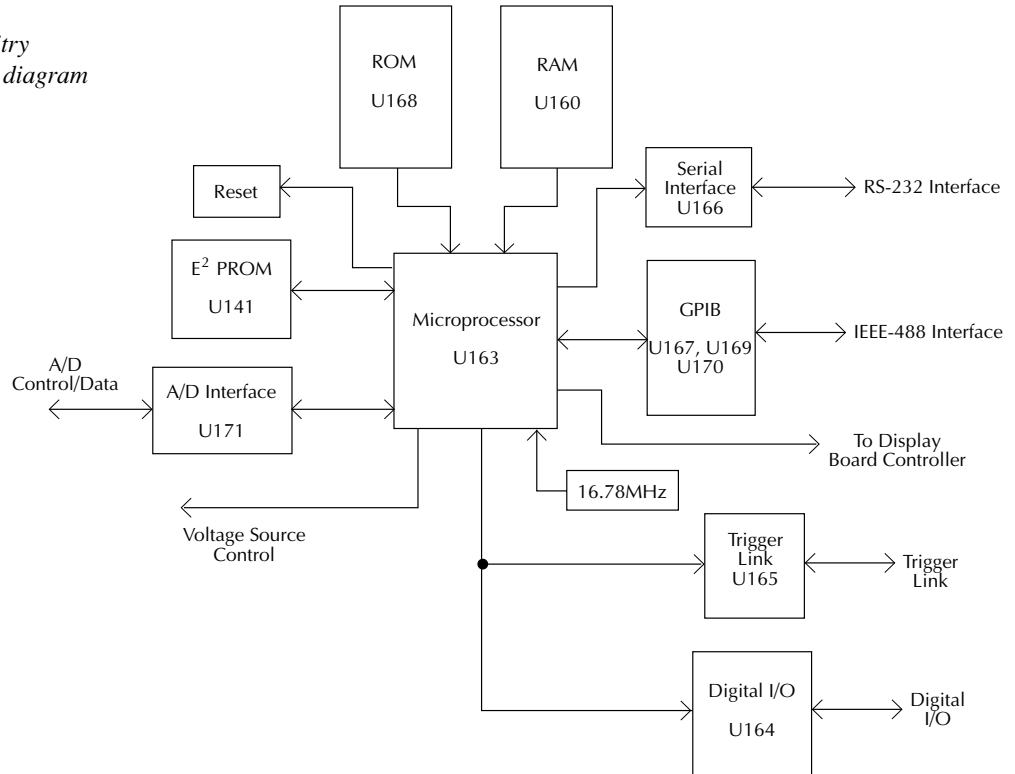

The core digital circuitry uses a Motorola 68332 microcontroller (U163) running at 16.78MHz. The memory configuration includes a flash EEPROM (U168) and a RAM (U160). Flash ROM support allows internal firmware upgrades using either the serial or GPIB port for downloading new firmware. All calibration constants and the saved setups are stored in a separate serial EEPROM (U141).

External communication is provided via GPIB and serial interfaces. A 9914 GPIB IEEE-488 standard interface IC (U167) is used for the GPIB, and a U166 provides the voltage conversion for the RS-232 port. U164 provides interfacing for the Digital I/O port.

Figure 4-10 shows a diagram for digital control that includes serial-to-parallel converters U134 to U136 and associated control signal nomenclatures.

Figure 4-10
Digital control circuits

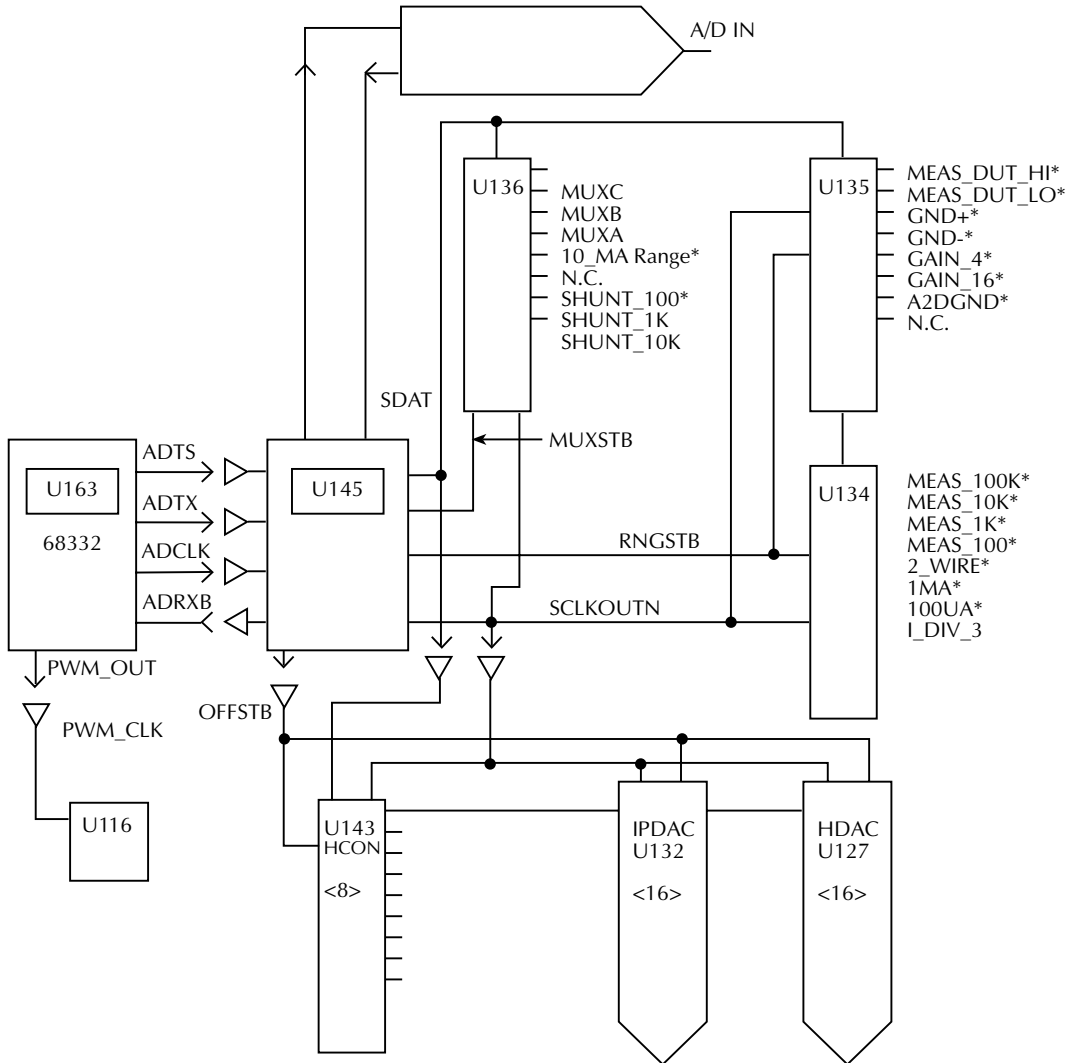

Display board circuits

U902 is the display microcontroller that controls the VFD (vacuum fluorescent display) and interprets key data. The microcontroller has four peripheral I/O ports that are used for the various control and read functions.

Display data is serially transmitted to the microcontroller from the digital board via the TXB line to the microcontroller PD0 terminal. In a similar manner, key data is serially sent back to the mother board through the RXB line via PD1. The 4MHz clock for the microcontroller is generated on the digital board.

DS901 is the VFD (vacuum fluorescent display) module, which can display up to 49 characters. Each character is organized as a 5×7 matrix of dots or pixels and includes a long underbar segment to act as a cursor.

The display uses a common multiplexing scheme with each character refreshed in sequence. U903 and U904 are the grid drivers, and U901 and U905 are the dot drivers. Note that dot driver and grid driver data is serially transmitted from the microcontroller (PD3 and PC1).

Troubleshooting

Troubleshooting information for the various circuits is summarized below. Refer to the component layout drawings at the end of Section 6 for component locations.

Display board checks

If the front panel display tests indicate that there is a problem on the display board, use Table 4-1. See “Principles of operation” for display circuit theory.

Table 4-1
Display board checks

Step	Item/component	Required condition	Remarks
1	Front panel test	Verify that all segments operate.	Use front panel display test.
2	J1033	+5V, $\pm 5\%$	Digital +5V supply.
3	U902, pin 1	Goes low briefly on power up, and then goes high.	Microcontroller RESET.
4	U902, pin 43	4MHz square wave.	Controller 4MHz clock.
5	U902, pin 32	Pulse train every 1 ms.	Control from main processor.
6	U902, pin 33	Brief pulse train when front panel key is pressed.	Key down data sent to main processor.

Power supply checks

Power supply problems can be checked out using Table 4-2. See “Principles of operation” for circuit theory on the power supply.

Table 4-2
Power supply checks

Step	Item/component	Required condition	Remarks
1	Line fuse	Check continuity.	Remove to check.
2	Line power	Plugged into live receptacle, power on.	Check for correct power-up sequence.
3	J1003, pin 3	+15V, $\pm 10\%$ (+15VPWR)	Referenced to TP121.
4	TP102	+5V, $\pm 5\%$ (+5VF)	Referenced to TP121.
5	TP112	+5V, $\pm 5\%$ (+5VD)	Referenced to U163, pin 19.
6	TP101	+15V, $\pm 5\%$ (+15VA)	Referenced to TP122.
7	TP105	-15V, $\pm 5\%$ (-15VA)	Referenced to TP122.
8	TP106	+5V, $\pm 5\%$ (+5VA)	Referenced to U104, pin 2.
9	TP107	+5V, $\pm 5\%$ (+5VRF)	Referenced to U104, pin 2.

Digital circuitry checks

Digital circuit problems can be checked out using Table 4-3. See “Principles of operation” for a digital circuit description.

Table 4-3
Digital circuitry checks

Step	Item/component	Required condition	Remarks
1	Power-on test	RAM OK, ROM OK.	Verify that RAM and ROM are functional.
2	U163 pin 19	Digital common. common.	All signals referenced to digital common.
3	U163 pin 7	+5V	Digital logic supply.
4	U163 pin 68	Low on power-up, then goes high.	MPU RESET line.
5	U163, A0-A19	Check for stuck bits.	MPU address bus.
6	U163, D0-D15	Check for stuck bits.	MPU data bus.
7	U163 pin 66	16.78MHz.	MPU clock.
8	U166 pin 7	Pulse train during RS-232 I/O.	RS-232 TX line.
9	U166 pin 8	Pulse train during RS-232 I/O.	RS-232 RX line.
10	U167 pins 34-42	Pulse train during IEEE-488 I/O.	IEEE-488 data bus.
11	U167 pins 26-31	Pulses during IEEE-488 I/O.	IEEE-488 command lines.
12	U167 pin 24	Low with remote enabled.	IEEE-488 REN line.
13	U167 pin 25	Low during interface clear.	IEEE-488 IFC line.
14	U163 pin 43	Pulse train.	D_ADDDATA
15	U163 pin 44	Pulse train.	D_DATA
16	U163 pin 45	Pulse train.	D_CLK
17	U163 pin 47	Pulse train	D_STB

Analog circuitry checks

Table 4-4 summarizes analog circuitry checks.

NOTE All measurements are with the V function selected, +5V output voltage, 5A current limit, and 1 Ω and 100 Ω resistors connected to the OUTPUT and INPUT terminals respectively. Turn OUTPUT ON while measuring.

Table 4-4
Analog circuitry checks

Step	Item/component ¹	Required condition	Remarks
1	TP103 ¹	+10.4V	H drive signal
2	TP104 ¹	+4V	H drive signal
3	TP108 ²	+6.3V	A/D reference signal
4	TP109 ²	-12.5V	-14V nominal supply
5	TP110 ²	+12.5V	+14V nominal supply
6	TP114 ²	0V	Sensor feedback signal
7	TP118 ²	Pulse train	Mux output to A/D converter
8	TP119 ²	0.5V	OUTPUT current sense signal
9	TP120 ²	5V	OUTPUT voltage sense signal

6. Measured with respect to F common (TP121).

7. Measured with respect to A2 common (TP122).

Internal fuse replacement

WARNING Disconnect the line cord and all cables and test leads from the instrument before replacing internal fuses.

CAUTION Do not install a fuse with a higher current rating than specified, or instrument damage may occur.

Power supply module fuse replacement

An internal fuse protects the power supply module from over-current conditions. Replace this fuse as follows:

1. Turn off the power, and disconnect the line cord and all other test leads and cables from the instrument.
2. Remove the case cover and mother board, as covered in Section 5.
3. Locate the fuse on the power supply module circuit board. The module is mounted on the chassis bottom.
4. Replace the fuse with one with the same current and voltage rating marked on the power supply module circuit board.

Digital I/O +5V supply fuse replacement

An internal fuse protects the +5V supply line on the ENABLE-DIG I/O connector from over-current conditions. Replace this fuse as follows:

1. Turn off the power, and disconnect the line cord and all other test leads and cables from the instrument.
2. Remove the case cover, as covered in Section 5.
3. Locate fuse F101 on the mother board. This fuse is located near the ENABLE-DIG I/O/RS-232 connector assembly (J1007) at the back of the board. See the 2510-100 component layout drawing at the end of Section 6 for location.
4. Carefully unsolder the blown fuse.
5. Replace the fuse with one with the following rating: 0.6A, Keithley part number FU-103, then solder it in place.
6. After soldering, clean the mother board as covered in Section 5, “Handling and cleaning precautions.”

No comm link error

A “No Comm Link” error indicates that the front panel processor has stopped communicating with the main processor, which is located on the mother board. This error indicates that the main processor ROM (U168) may require reseating in its socket. The ROM may be reseated as follows:

1. Turn off the power, and disconnect the line cord and all other test leads and cables from the instrument.
2. Remove the case cover as outlined in Section 5.
3. Locate the firmware ROM, U168, located on the digital board. This ROM is the only IC installed in a socket. (Refer to the 2510-100 component layout drawing at the end of Section 6 for exact location.)
4. Carefully push down on the ROM IC to make sure it is properly seated in its socket.

CAUTION Be careful not to push down excessively, or you might crack the mother board.

5. Connect the line cord, and turn on the power. If the problem persists, additional troubleshooting will be required.

5 Disassembly

Introduction

This section explains how to handle, clean, and disassemble the Model 2510. Disassembly drawings are located at the end of this section.

Handling and cleaning

To avoid contaminating PC board traces with body oil or other foreign matter, avoid touching the PC board traces while you are repairing the instrument. Mother board areas covered by the shield have high-impedance devices or sensitive circuitry where contamination could cause degraded performance.

Handling PC boards

Observe the following precautions when handling PC boards:

- Wear cotton gloves.
- Only handle PC boards by the edges and shields.
- Do not touch any board traces or components not associated with repair.
- Do not touch areas adjacent to electrical contacts.
- Use dry nitrogen gas to clean dust off PC boards.

Solder repairs

Observe the following precautions when you must solder a circuit board:

- Use an OA-based (organic activated) flux, and take care not to spread the flux to other areas of the circuit board.
- Remove the flux from the work area when you have finished the repair by using pure water with clean, foam-tipped swabs or a clean, soft brush.
- Once you have removed the flux, swab only the repair area with methanol, then blow-dry the board with dry nitrogen gas.
- After cleaning, allow the board to dry in a 50°C, low-humidity environment for several hours.

Static sensitive devices

CMOS devices operate at very high impedance levels. Therefore, any static that builds up on you or your clothing may be sufficient to destroy these devices if they are not handled properly. Use the following precautions to avoid damaging them:

CAUTION Many CMOS devices are installed in the Model 2510. Handle all semiconductor devices as being static sensitive.

- Transport and handle ICs only in containers specially designed to prevent static build-up. Typically, you will receive these parts in anti-static containers made of plastic or foam. Keep these devices in their original containers until ready for installation.
- Remove the devices from their protective containers only at a properly grounded work station. Ground yourself with a suitable wrist strap.
- Handle the devices only by the body; do not touch the pins.
- Ground any printed circuit board into which a semiconductor device is to be inserted to the bench or table.
- Use only anti-static type desoldering tools.
- Use only grounded-tip solder irons.
- Once the device is installed in the PC board, it is normally adequately protected, and you can handle the boards normally.

Assembly drawings

Use the assembly drawings located at the end of this section to assist you as you disassemble and reassemble the Model 2510. Refer to these drawings for information about the Keithley part numbers of most mechanical parts in the unit. Assembly drawings include:

- Front panel assembly — 2510-040
- Chassis/power module assembly — 2510-050
- Front panel/chassis assembly — 2510-051
- Chassis assembly — 2510-052
- Final inspection — 2510-080

Case cover removal

Follow the steps below to remove the case cover to gain access to internal parts.

WARNING Before removing the case cover, disconnect the line cord and any test leads from the instrument.

1. **Remove handle** — The handle serves as an adjustable tilt-bail. Adjust its position by gently pulling it away from the sides of the instrument case and swinging it up or down. To remove the handle, swing the handle below the bottom surface of the case and back until the orientation arrows on the handles line up with the orientation arrows on the mounting ears. With the arrows lined up, pull the ends of the handle away from the case.
2. **Remove mounting ears** — Remove the screw that secures each mounting ear. Pull down and out on each mounting ear.

NOTE When reinstalling the mounting ears, make sure to mount the right ear to the right side of the chassis, and the left ear to the left side of the chassis. Each ear is marked “RIGHT” or “LEFT” on its inside surface.

3. **Remove rear bezel** — To remove the rear bezel, loosen the two screws that secure the rear bezel to the chassis, then pull the bezel away from the case.
4. **Remove bottom screws** — Remove the four screws that secure the case to the chassis. They are located on the bottom of the case.
5. **Remove chassis** — To remove the case, grasp the front bezel of the instrument, and carefully slide the chassis forward. Slide the chassis out of the metal case.

Mother board removal

Perform the following steps to remove the mother board. This procedure assumes that the case cover is already removed.

1. Remove the IEEE-488, ENABLE-DIG I/O, and RS-232 fasteners.
The IEEE-488, ENABLE-DIG I/O, and RS-232 connectors each have two hex-head screws that secure the connectors to the rear panel. Remove these screws.
2. Remove mother board mounting screws.
Remove the two mounting screws that secure the mother board to the chassis.
3. Unplug cables:
 - Unplug the display board ribbon cable from J1014.
 - Unplug the cables going to the power supply from J1003.
 - Unplug the cable going to the OUTPUT indicator from J102.
 - Unplug the fan cable from J1015.

4. Remove mother board.

Slide the mother board forward until the slots line up with the guide pins, then remove the board.

During reassembly, replace the mother board, and start the IEEE-488, ENABLE-DIG I/O, and RS-232 connector screws and the board mounting screws. Tighten all the fasteners once they are all in place and the board is correctly aligned. Be sure to plug in all cables.

Front panel disassembly

Use the following procedure to remove the display board and/or the pushbutton switch pad.

1. Remove the power switch rod. Carefully disconnect the power switch rod from the power switch mounted on the rear panel power module. Slide the rod toward the rear until it clears the access hole in the front panel, then remove the rod.
2. Remove the front panel assembly. This assembly has four retaining clips that snap onto the chassis over four pem nut studs. Two retaining clips are located on each side of the front panel. Pull the retaining clips outward and, at the same time, pull the front panel assembly forward until it separates from the chassis.
3. Unplug the display board ribbon cables.
4. Using a thin-bladed screw driver, pry the plastic PC board stop (located at the bottom of the display board) until the bar separates from the casing. Pull the display board from the front panel.
5. Remove the switch pad by pulling it from the front panel.

Removing power components

The following procedures to remove the power supply and/or power module require that the case cover and mother board be removed, as previously explained.

Power supply module removal

Perform the following steps to remove the power supply module:

1. Remove the wires that connect the power supply module to the rear panel power module.
2. Remove any cable clamps or cable ties that secure the power supply module wires.
3. Remove the screws that secure the power supply to the chassis bottom, then remove the module.

Power module removal

Perform the following steps to remove the rear panel power module:

1. Disconnect the power module's ground wire. This green and yellow wire connects to a threaded stud on the chassis with a kep nut.
2. Squeeze the latches on either side of the power module while pushing the module from the access hole.

Fan removal

1. Remove the two nuts that secure the fan to the rear of the chassis.
2. Remove the fan from the chassis.

Instrument reassembly

Reassemble the instrument by reversing the previous disassembly procedures. Make sure that all parts are properly seated and secured, and that all connections are properly made.

WARNING To ensure continued protection against electrical shock, verify that power line ground (green and yellow wire attached to the power module) is connected to the chassis.

Also make sure the four bottom case screws are properly installed to secure and ground the case cover to the chassis.

2510-040

ON

LTR	ECA NO.	REVISION	ENG	DATE
B	25369	ADDED CA-239-1A	ST	1/12/01
BI	26779	Add T-7788		

STEP 1

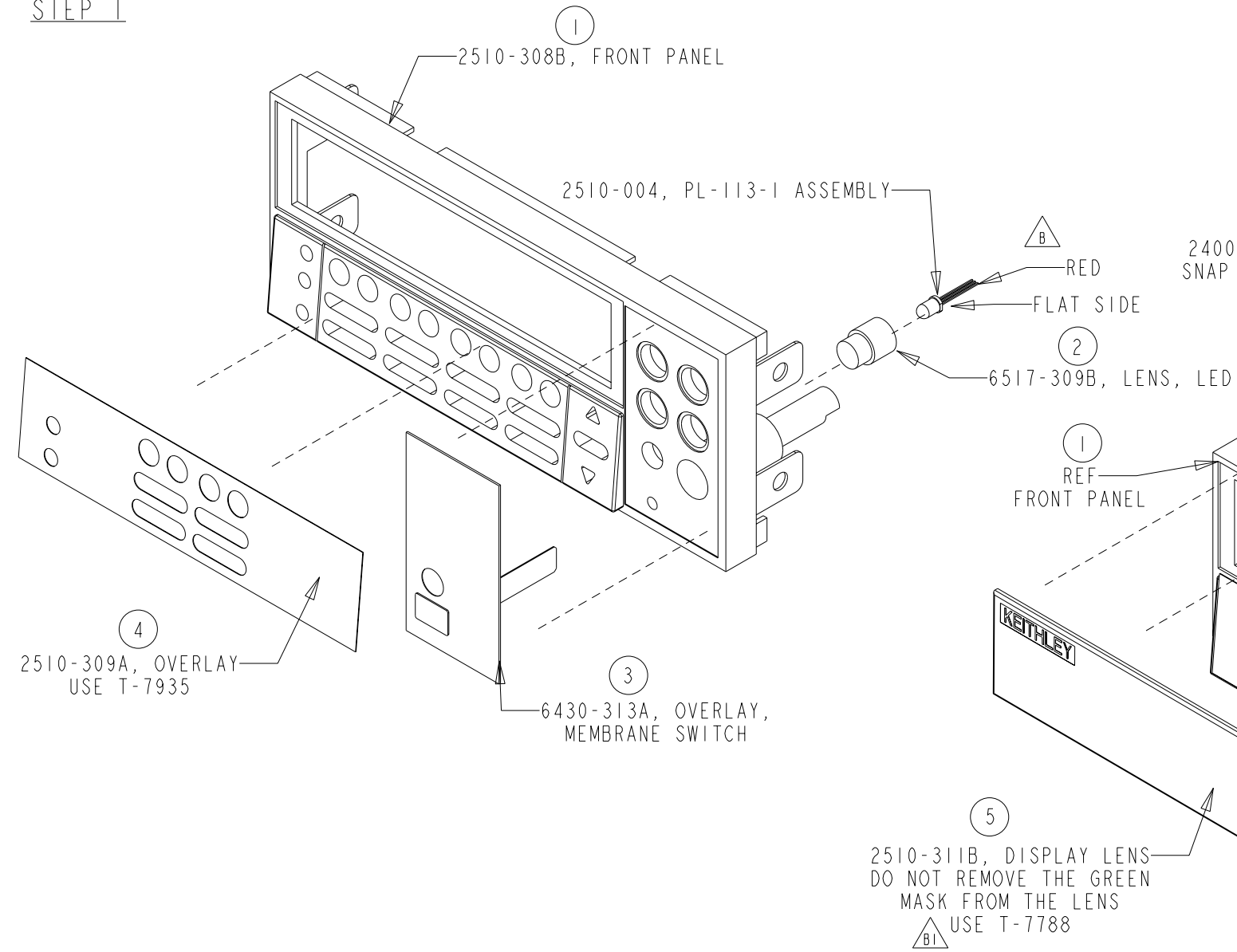

STEP 2

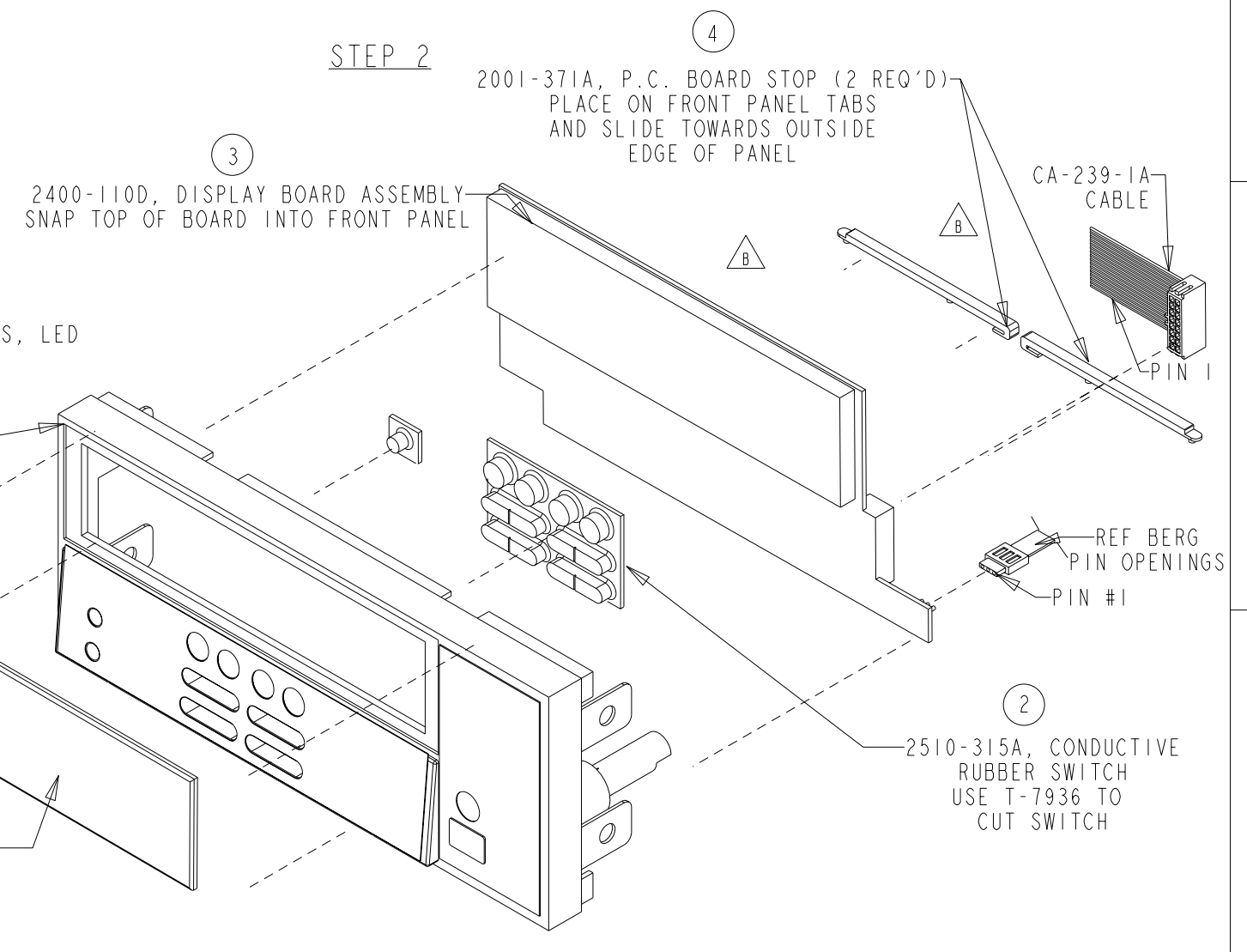

www.valuetronics.com

PART NUMBER	QTY	DESCRIPTION
2510-308B	1	FRONT PANEL
2400-110D	1	DISPLAY BOARD ASSEMBLY
6430-313A	1	OVERLAY, MEMBRANE SWITCH
2510-311B	1	DISPLAY LENS
2510-315A	1	CONDUCTIVE RUBBER SWITCH
2001-371A	2	P.C. BOARD STOP
6517-309B	1	LENS, LED
2510-004	1	CRIMP ASSEMBLY
2510-309A	1	OVERLAY
CA-239-1A	1	CABLE

2510	2510-052	Front Panel/Chassis Ass'y	1
MODEL	NEXT ASSEMBLY	NEXT PROCESS STEP	QTY
USED ON			

DO NOT SCALE THIS DRAWING		DIMENSIONAL TOLERANCES UNLESS OTHERWISE SPECIFIED		DATE 9-9-99	SCALE - - - - -	TITLE	
Keithley Instruments Inc. Cleveland, Ohio 44139		XX = ±.015	ANG. = ±°	DRN.	MAT	ENG APPR.	LS
		XXX = ±.005		FRAC. = ±1/64		MATERIAL	
		SURFACE MAX. $\sqrt{63}$		FINISH		B	NO. 2510-040

050-019Z

ON

LTR	ECA NO.	REVISION	ENG	DATE
B	24166	Added ST-217-1	ST	3/20/00
B1	24459	2510-302B Was 2510-302A	ST	5/18/00
B2	25369	CHANGED TORQUE SPEC.	ST	1/12/01
B3	26756	2510-302C Was 2510-302B		

DETAIL A POWER MODULE WIRING

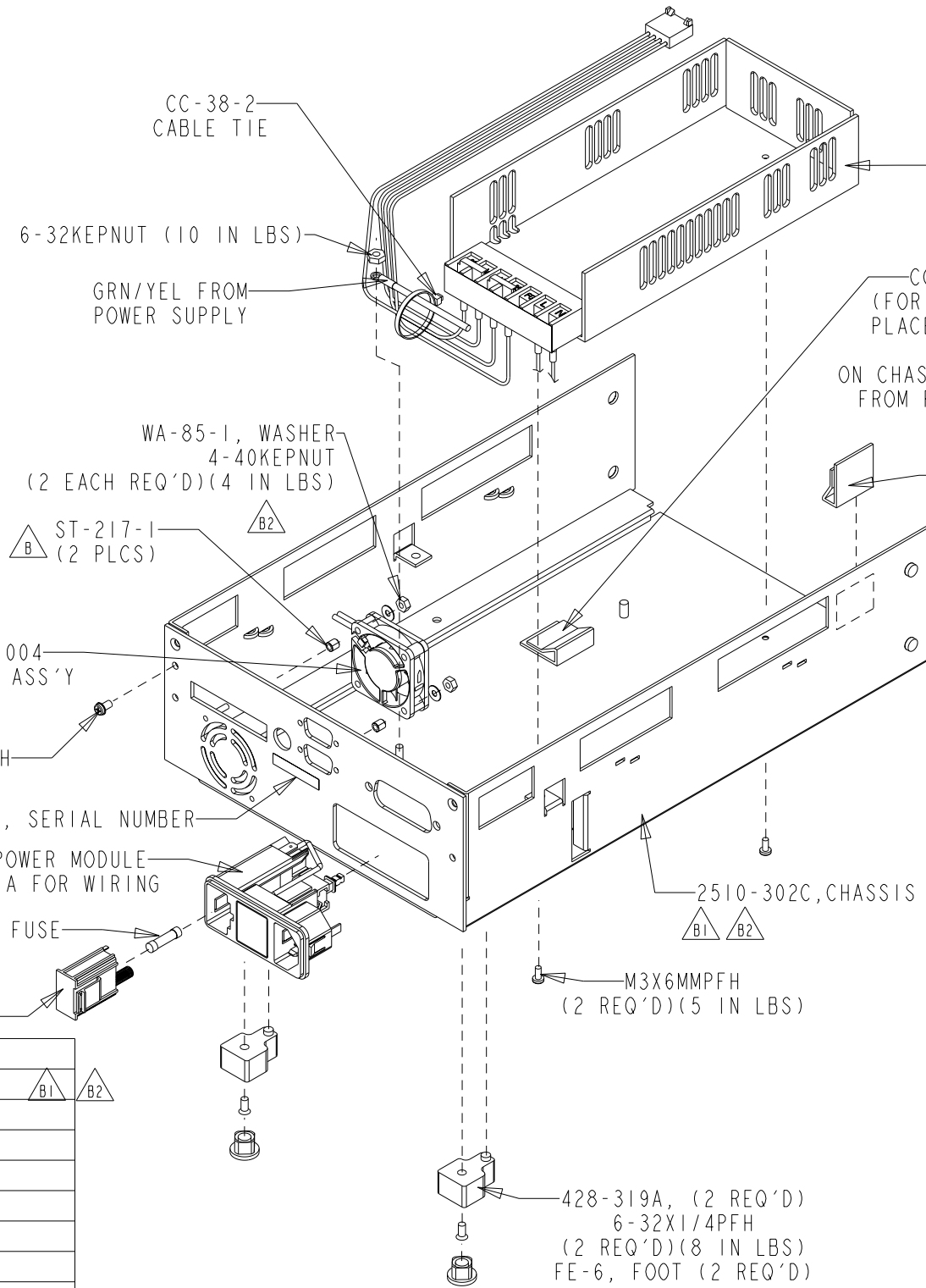
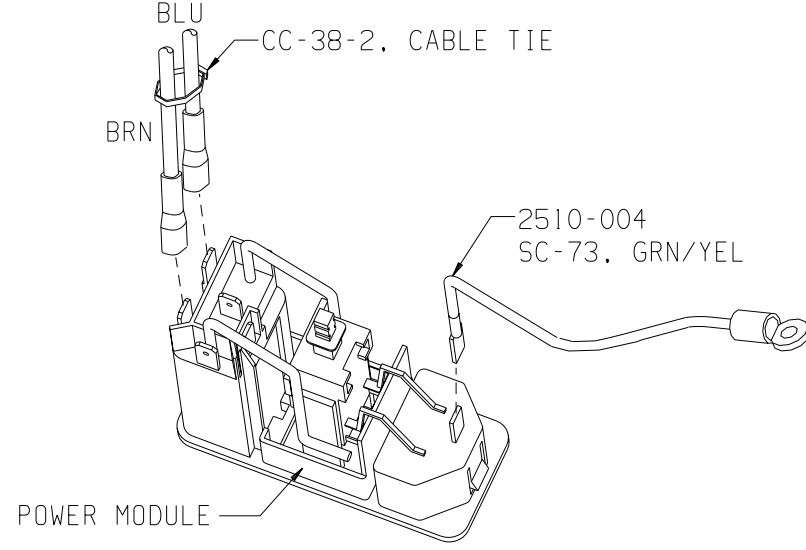

PS-77-1A, POWER SUPPLY
SEE DETAIL B
INSTALL WIRES BEFORE
PLACING IN CHASSIS

CC-37, CABLE CLAMP
(FOR POWER SUPPLY WIRES)
PLACE EDGE OF CLAMP NEXT
TO POWER SUPPLY
ON CHASSIS BOTTOM, INSTALL 5"
FROM FRONT EDGE OF CHASSIS

CC-37, CABLE CLAMP
USE T-7946

DETAIL B POWER SUPPLY WIRING

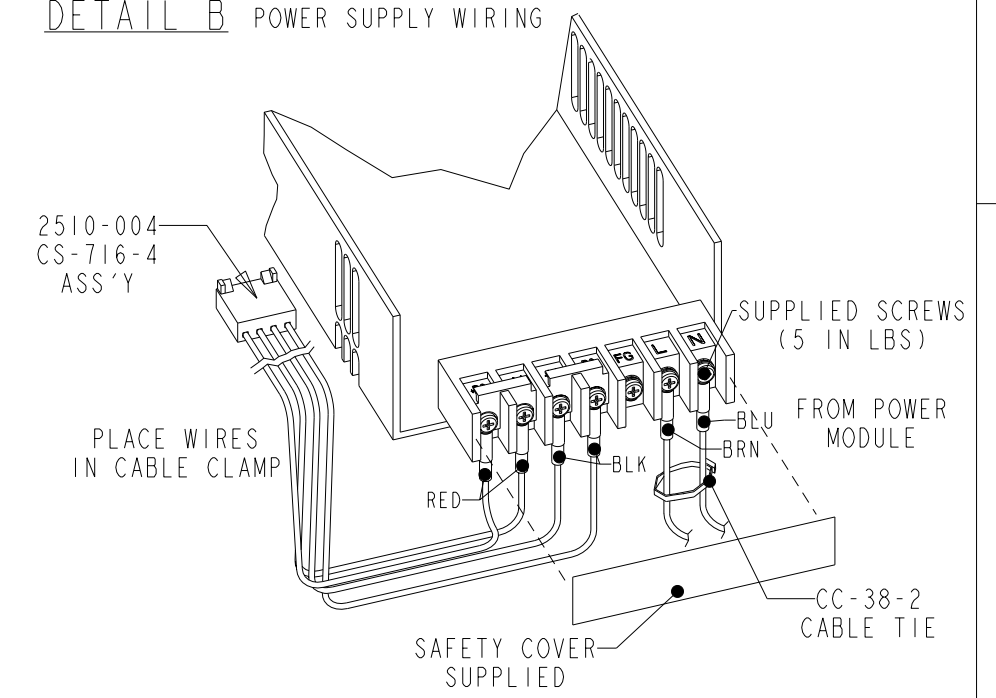

PART NUMBER	QTY	DESCRIPTION
2510-302C	1	CHASSIS
PS-77-1A	1	POWER SUPPLY
428-319A	2	FOOT
FE-6	2	FOOT
FH-39	1	FUSE HOLDER
FU-106-2.5	1	FUSE 2.5 AMP
PM-1-1B	1	POWER MODULE
M3X6MMPFH	2	MILLIMETER PHIL PAN HEAD SCREW
2510-004	1	WIRE CRIMP ASSEMBLY
4-40KEPNUT	2	KEPNUT
6-32KEPNUT	1	KEPNUT
6-32X1/4PFH	2	PHIL FLAT HEAD SCREW
CC-37	2	CABLE CLAMP
MC-285	1	SERIAL NUMBER
WA-85-1	2	WASHER
6-32X5/16PPH	1	PHIL PAN HEAD SCREW
CC-38-2	3	CABLE TIE
ST-217-1	2	SPACER

2510	2510-051	Front Panel/Chassis Assembly	1
MODEL	NEXT ASSEMBLY	NEXT PROCESS STEP	QTY
USED ON			

DO NOT SCALE THIS DRAWING

DIMENSIONAL TOLERANCES UNLESS OTHERWISE SPECIFIED

XX = ±.015 ANG. = ±°

XXX = ±.005 FRAC. = ±1/64

SURFACE MAX. \sqrt{R}

DATE 22-Sep-99 SCALE - - - - - TITLE

DRN. MAT ENG APPR. LS Chassis/Power Module Assembly

MATERIAL FINISH

NO. 2510-050

www.valuetronics.com

190-019Z

ON

D3	25950	2510-100E1 Was 2510-100E	ST	10/30/01
D4	26175	2510-100F1 Was 2510-100E1		

LTR	ECA NO.	REVISION	ENG	DATE
D	25369	DEL CA-239-1A& CHG'D 2510-100D	ST	1/12/01
D1	25302	2510-100D1 WAS 2510-100D	ST	2/5/01
D2	25768	2510-100E Was 2510-100D1	ST	10/30/01

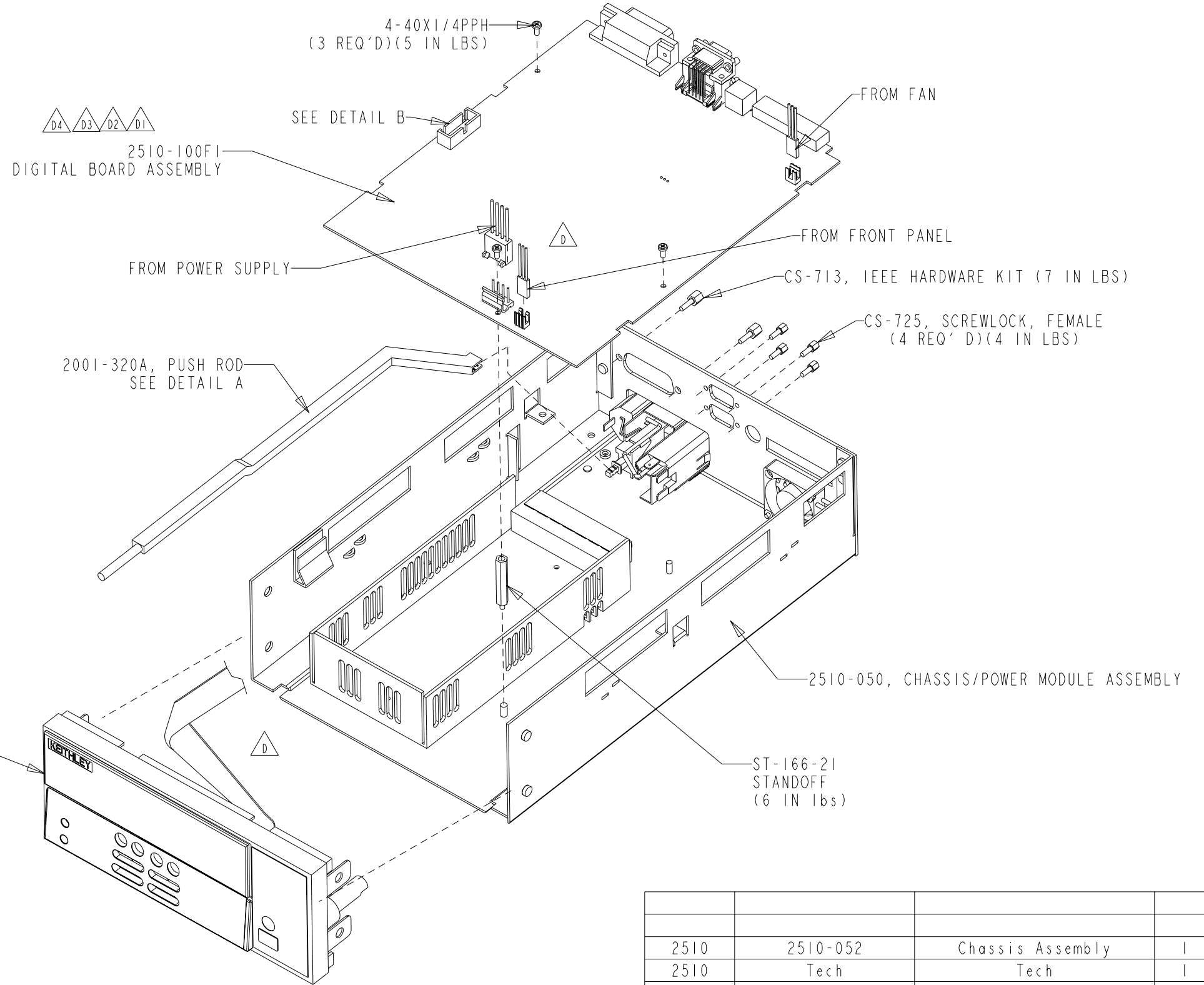
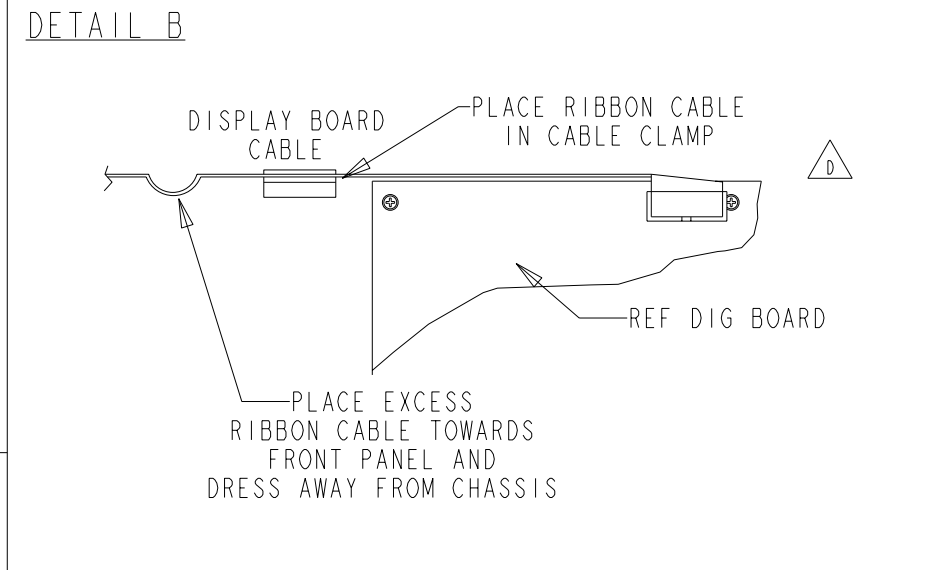
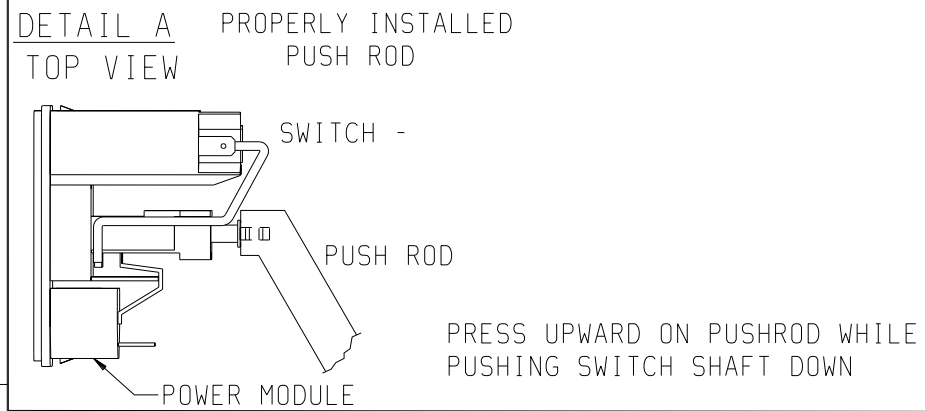

www.valuetronics.com

PART NUMBER	QTY	DESCRIPTION
2510-050	1	CHASSIS/POWER MODULE ASSEMBLY
2510-040	1	FRONT PANEL ASSEMBLY
2510-100F1 Δ D4	1	DIGITAL BOARD ASSEMBLY Δ D1 Δ D2 Δ D3
CS-713	1	IEEE HARDWARE KIT
CS-725	4	SCREWLOCK, FEMALE
2001-320A	1	PUSH ROD
4-40X1/4PPH	3	PHIL PAN HEAD SCREW Δ D
ST-166-21	1	STANDOFF

2510	2510-052	Chassis Assembly	1
2510	Tech	Tech	1
MODEL	NEXT ASSEMBLY	NEXT PROCESS STEP	QTY
USED ON			

DO NOT SCALE THIS DRAWING

KEITHLEY Keithley Instruments Inc. Cleveland, Ohio 44139

DIMENSIONAL TOLERANCES UNLESS OTHERWISE SPECIFIED
 XX = \pm .015 ANG. = \pm °
 XXX = \pm .005 FRAC. = \pm 1/64
 SURFACE MAX. \sqrt{R}

DATE 22-Sep-99 SCALE - - - -
 DRN. MAT ENG APPR. LS
 MATERIAL FINISH

TITLE
 Front Panel/Chassis Assembly

NO. 2510-051

2510-052

ON

LTR	ECA NO.	REVISION	ENG	DATE
A	24008	Released	ST	1/5/00

STEP 1

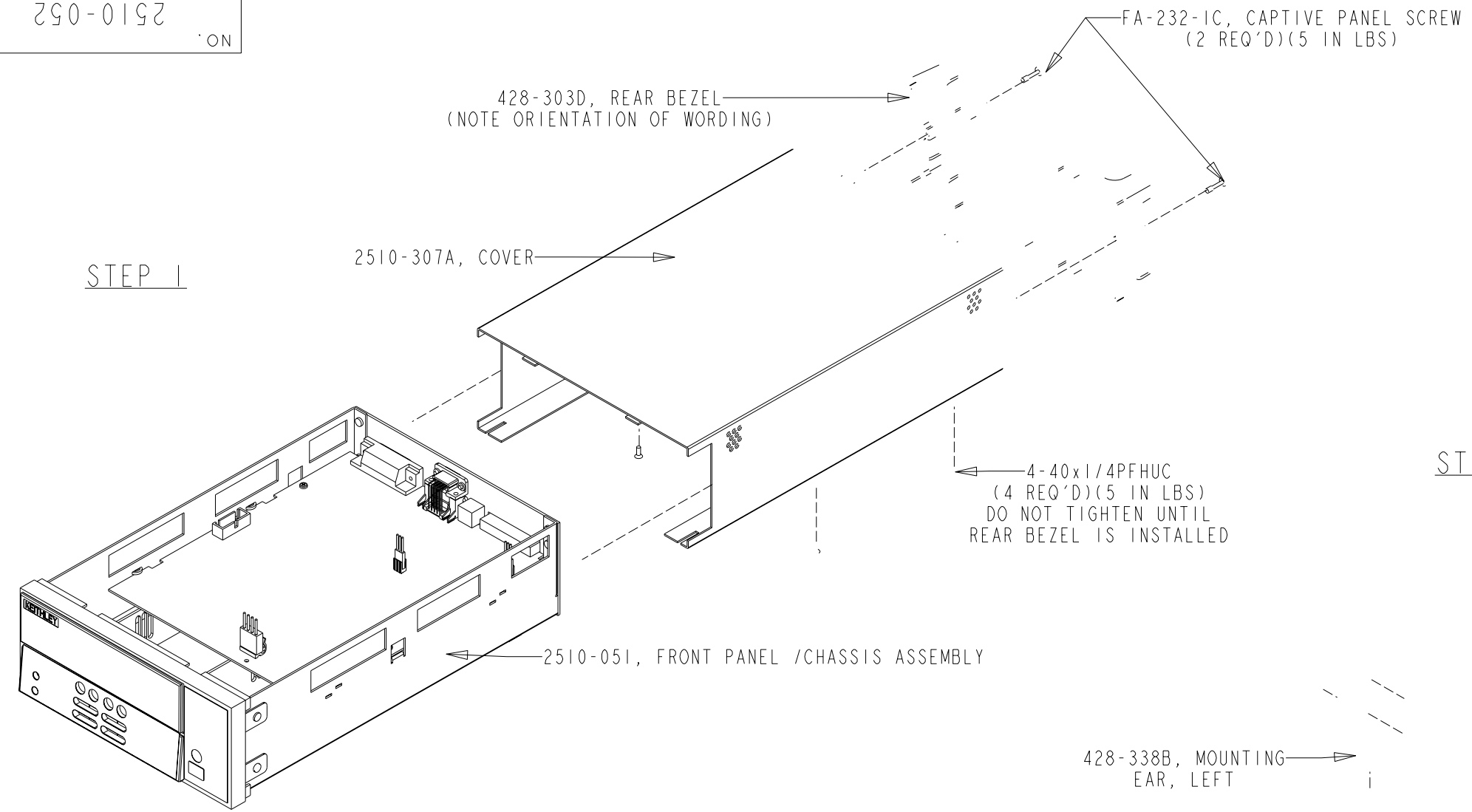

STEP 2

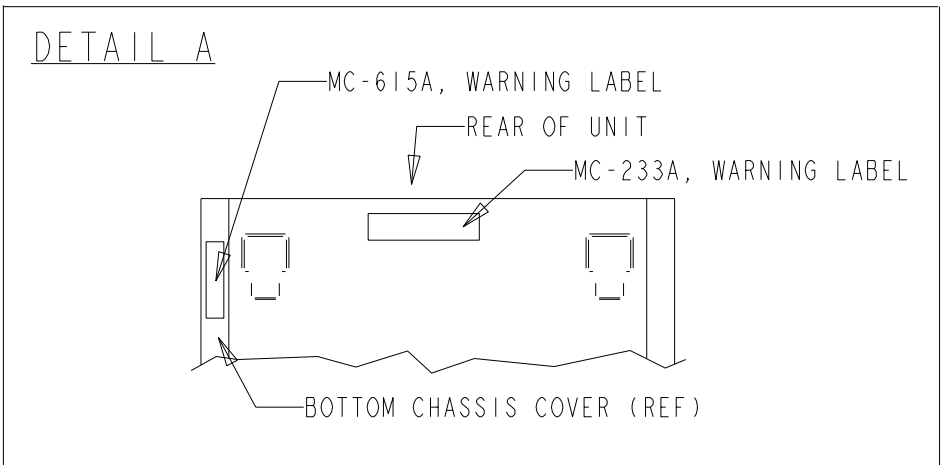
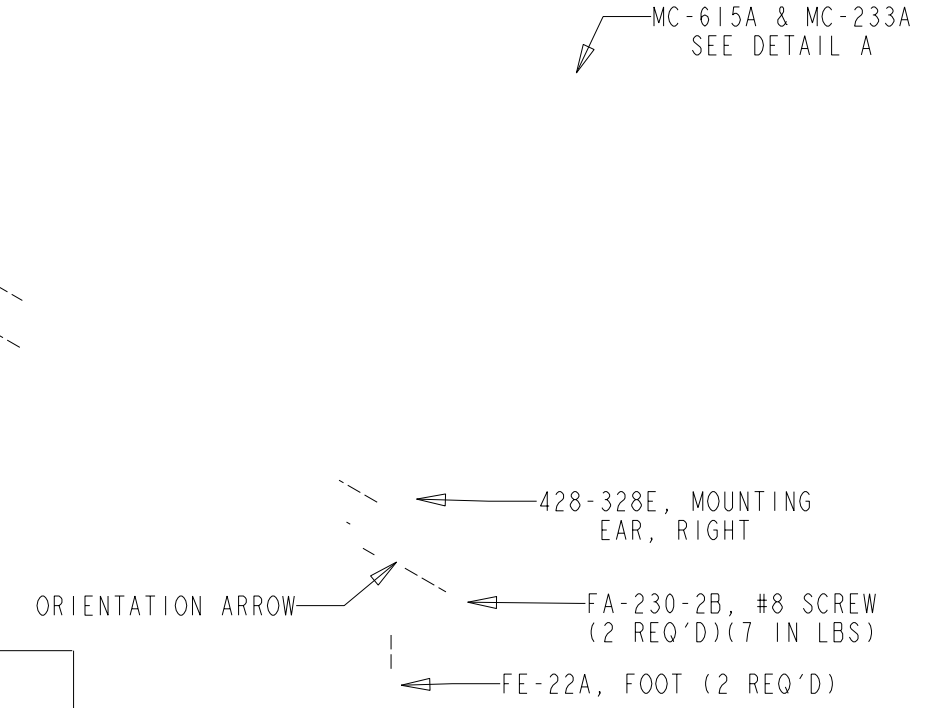

PART NUMBER	QTY	DESCRIPTION
2510-051	1	FRONT PANEL/CHASSIS ASSEMBLY
2510-307A	1	COVER
428-328E	1	MOUNTING EAR RIGHT
428-338B	1	MOUNTING EAR LEFT
FA-230-2B	2	FASTENER
FE-22A	2	FOOT
MC-615A	1	WARNING LABEL
4-40x1/4PFHUC	4	PHIL FLAT HEAD UNDERCUT SCREW
428-303D	1	REAR BEZEL
FA-232-1C	2	CAPTIVE PANEL SCREW
MC-233A	1	LABEL, WARNING

MODEL	NEXT ASSEMBLY	NEXT PROCESS STEP	QTY
2510	2510-080	Final Inspection	1
2510	Tech	Tech	1

DO NOT SCALE THIS DRAWING

DIMENSIONAL TOLERANCES UNLESS OTHERWISE SPECIFIED

XX = ±.015 ANG. = ±1°

XXX = ±.005 FRAC. = ±1/64

SURFACE MAX. $\sqrt{63}$

DATE 23-Sep-99 SCALE - - - - - TITLE Chassis Assembly OP6

DRN. Mat ENG APPR.

MATERIAL FINISH

NO. 2510-052

KEITHLEY Keithley Instruments Inc. Cleveland, Ohio 44139

www.valuetronics.com

080-019Z

ON

LTR	ECA NO.	REVISION	ENG	DATE
E	26769	OPTP-950-00* Was 2510-900-00* PA-804A Was PA-791A		

Recommended Procedure:

1. Turn the UUT ON.
2. Verify all display segments and annunciator turn ON for a few seconds.
3. Verify Firmware Rev.
4. Verify GPIB Address 15.
5. Wait until front panel displays all numbers.

To change GPIB Address:

1. Press MENU.
2. Using the Left and Right Arrow Keys, Select COMMUNICATION and Press ENTER.
3. Using the Left and Right Arrow Keys, Select GPIB and Press ENTER.
4. Using UP and DOWN Arrow Keys, Set Address to 15 and Press ENTER.
5. To EXIT, Press EXIT.

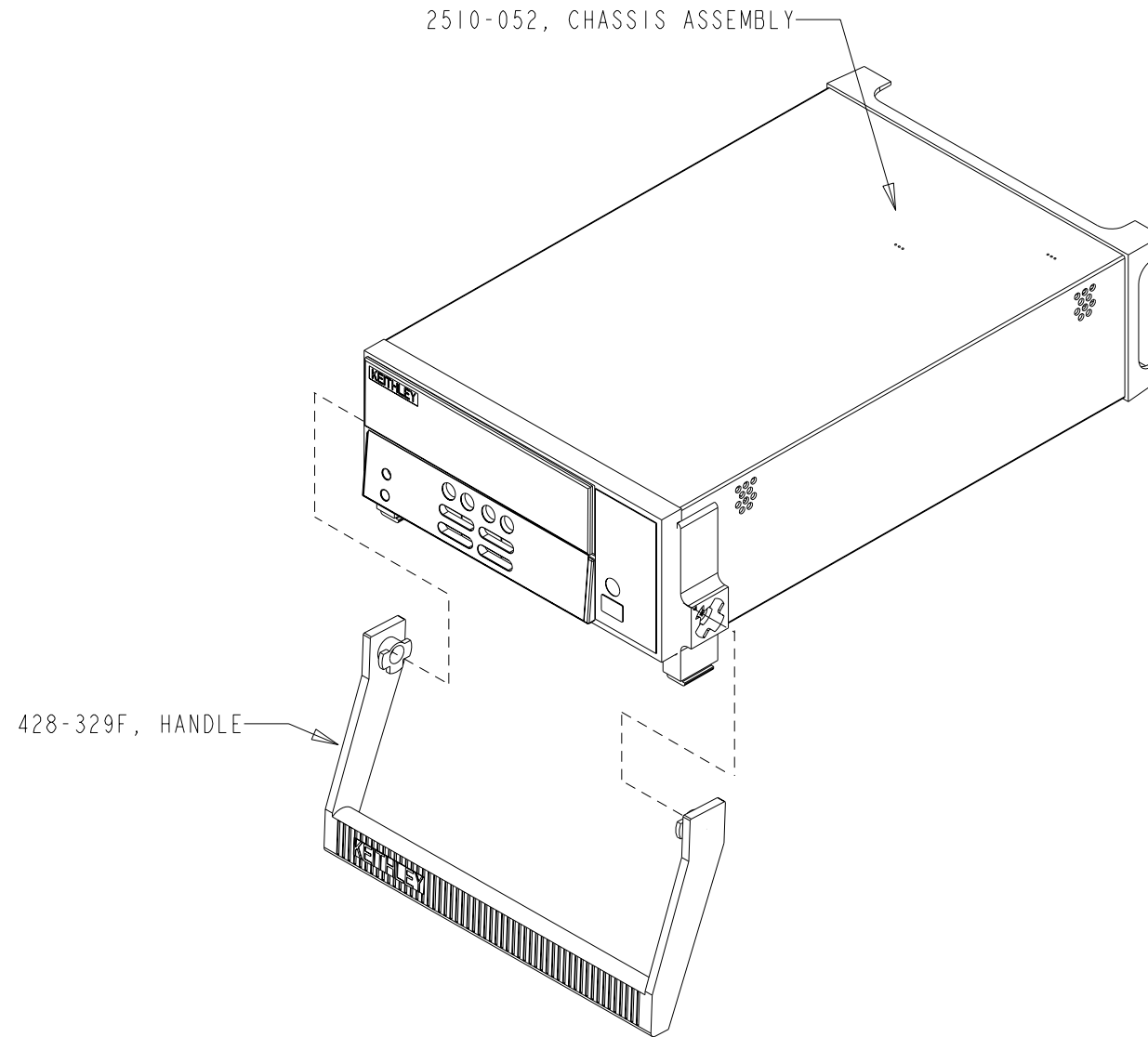

PERFORM HIPOT TEST
PER MS-1537 TO IEC
VOLTAGE SPEC

NOTE:
UNIT IS TO BE SHIPPED WITH
GREEN MASK ON THE LENS

PLACE CERTIFICATE OF CALIBRATION ON TOP OF UNIT, THEN PLACE INTO PO-14-4,
CHIPLOC BAG AND SEND WITH W.O. SHIPPING KIT ITEMS TO AUDIT

CALL STOCKROOM FOR WORK ORDER
SHIPPING KIT BEFORE SENDING TO F.G.S.

PART NUMBER	QTY	DESCRIPTION
2510-052	1	CHASSIS ASSEMBLY
PO-14-4	1	CHIPLOC BAG
CO-7	1	LINE CORD W.O. SHIPPING KIT
OPTO-950-00	1	MANUAL PACKAGE W.O. SHIPPING KIT
-----	1	CERT OF CAL (PA-214, PRINTED IN PROD)
428-329F	1	HANDLE
CS-846	1	CONNECTOR W.O. SHIPPING KIT
PA-804A	1	PACKING LIST W.O. SHIPPING KIT
MC-960A	1	LABEL, REAR PANEL W.O. SHIPPING KIT

2510	Audit	Audit	1
MODEL	NEXT ASSEMBLY	NEXT PROCESS STEP	QTY
USED ON			

Keithley Instruments Inc. Cleveland, Ohio 44139	DO NOT SCALE THIS DRAWING	DIMENSIONAL TOLERANCES UNLESS OTHERWISE SPECIFIED	DATE 23-Sep-99	SCALE - - - - -	TITLE
	XX = ±.015 ANG. = ±1° XXX = ±.005 FRAC. = ±1/64 SURFACE MAX. \sqrt{R}	DRN. Mat	ENG APPR. LS	Final Inspection	
		MATERIAL	B	NO.	2510-080
		FINISH			

www.valuetronics.com

6

Replaceable Parts

Introduction

This section contains replacement parts information and component layout drawings for the Model 2510.

Parts lists

The electrical parts lists for the Model 2510 are shown in the tables at the end of this section. For part numbers to the various mechanical parts and assemblies, use the Miscellaneous parts list and the assembly drawings provided at the end of Section 5.

Ordering information

To place an order, or to obtain information concerning replacement parts, contact your Keithley representative or the factory (see inside front cover for addresses). When ordering parts, be sure to include the following information:

- Instrument model number (Model 2510)
- Instrument serial number
- Part description
- Component designation (if applicable)
- Keithley part number

Factory service

If the instrument is to be returned to Keithley Instruments for repair, perform the following:

- Call the Repair Department at 1-800-552-1115 for a Return Material Authorization (RMA) number.
- Complete the service form at the back of this manual, and include it with the instrument.
- Carefully pack the instrument in the original packing carton.
- Write ATTENTION REPAIR DEPARTMENT and the RMA number on the shipping label.

Component layouts

Keithley.com

The component layouts for the circuit boards are provided on the following pages. Drawings include:

- Mother board — 2510-100
- Display board — 2400-110

Table 6-1*Mother board parts list*

Circuit designation	Description	Keithley part no.
C101,C102,C204,C205,C206,C207	CAP, 680U, 20%, 50V ALUM ELEC	C-578-680
C103,C106	CAP, 2.2U, 10%, 50V TANTALUM	C-563-2.2
C104,105,118,121,122,125,126,127,157,158	CAP, .1UF, 20%, 50V CERAMIC	C-418-.1
C107,109,112,114,135,136,143,152,155,161	CAP, .1UF, 10%, 25V, CERAMIC	C-495-.1
C110,C113	CAP, .033U, 10%, 50V CERAMIC	C-491-.033
C111,C128,C188,C189,C192,C194,C290	CAP, 1UF, 20%, 35V, TANTALUM	C-494-1
C115,C175	CAP, 2200P, 1%, 50V CERAMIC	C-532-2200P
C116,C174	CAP, 220PF, 10%, 100V, CERAMIC	C-451-220P
C119,C172,C185	CAP, 100PF, 5%, 100V CERAMIC	C-465-100P
C120	CAP, 470P, 10%, 100V, CERAMIC	C-451-470P
C123,131,132,133,134,137,138,141,142,146	CAP, 22UF, 20%, 25V, TANTALUM	C-440-22
C130	CAP, 100UF, 20%, 10V, ALUM ELEC	C-483-100
C139,C140,C144,C145	CAP, 47U, 20%, 50V, ALUM	C-579-47
C151,156,178,187,199,210,236,150	CAP, 22UF, 20%, 25V, TANTALUM	C-440-22
C162,163,167,170,171,181,182,196,198,200	CAP, .1UF, 10%, 25V, CERAMIC	C-495-.1
C164,C184	CAP, 2200P, 10%, 100V CERAMIC	C-430-2200P
C165,166,186,193,220,225,226,229,230,231	CAP, .01UF, 10%, 50V CERAMIC	C-491-.01
C168,169,183,195,197,250,268	CAP, 47P, 5%, 100V, CERAMIC	C-465-47P
C173,251,266,117,147,297-305	CAP, 1000PF,10%, 50V, MONO CERAMIC	C-452-1000P
C176,177,180,208,209,214,215,216,253,271	CAP, .1UF, 20%, 50V CERAMIC	C-418-.1
C179,C247,C260,C265,C275,C292	CAP, 100P, 10%, 100V CERAMIC	C-451-100P
C201,202,203,211,212,213,219,221,222	CAP, .1UF, 10%, 25V, CERAMIC	C-495-.1
C223	CAP, 47PF, 10%, 100V, CERAMIC	C-451-47P
C224,C228	CAP, 15P, 1%, 100V CERAMIC	C-512-15P
C227,233,234,237,238,239,240,241,243	CAP, .1UF, 10%, 25V, CERAMIC	C-495-.1
C232,C235,C242,C245,C282	CAP, .01UF, 10%, 50V CERAMIC	C-491-.01
C246,248,249,252,254,255,256,261,267,269	CAP, .1UF, 10%, 25V, CERAMIC	C-495-.1
C270,C295,C218,C296	CAP, .1UF, 20%, 50V CERAMIC	C-418-.1
C272,C273	CAP, 1UF, 20%, 100V, CERAMIC	C-487-1
C277,278,280,281,283-289,291,293,294	CAP, .1UF, 10%, 25V, CERAMIC	C-495-.1
C279	CAP, .1UF, 20%,100V, CERAMIC	C-436-.1
CR101,CR113	DIODE, MBRS140T3	RF-110

Table 6-1 (cont.)
Mother board parts list

Circuit designation	Description	Keithley part no.
CR102	ULTRA FAST BRIDGE RECTIFIER, EDF1BM	RF-123
CR103,CR104,CR105,CR106	ULTRAFAST POWER RECTIFIER	RF-107
CR107,CR108,CR130	DIODE, SWITCHING, MMBD914	RF-83
CR109,CR110,CR111,CR112,CR133	DIODE, SWITCHING, MMSD914T19	RF-112
CR114	DIODE, DUAL HSM-2822T31	RF-95
CR115,CR116,CR122-CR129,CR131,CR132	DIODE, DUAL SWITCHING, BAV99L	RF-82
CR117,CR118,CR119,CR120,CR121	DIODE, DUAL COMMON ANODE BAW56LT2	RF-98
F101	POLYSWITCH, SMD030-2	FU-103
HS101,HS105-HS110	HEAT SINK	HS-55
J1001	CONNECTOR, MODULES	CS-834
J1003	CONNECTOR, HEADER	CS-784-4
J1006	CONN, MICRODIN W/GND FINGERS	CS-792
J1007	CONN, D-SUB DUAL STACK M-F	CS-1072-1
J1008	CONN, RIGHT ANGLE, 24 PIN	CS-501
J101	CONN,BERG	CS-339
J1014	CONN, HEADER STRAIGHT SOLDER PIN	CS-368-16
J102,J1015	LATCHING HEADER,FRICTON, SGL ROW	CS-724-3
K101	N.C RELAY, 1 FORMB, AQV214	RL-176
K102	MINI POWER RELAY, DK1A-5V	RL-249
L101,L105	CHOKE, 22UH	CH-66-22
L102,L103,L104	FERRITE BEAD	CH-91
L106,L107,L116	HIGH CURRENT TOROID	CH-103-1
L108,L109,L110,L111,L112,L113,L114,L118	FERRITE CHIP 600 OHM BLM32A07	CH-62
L115	EMI SUPPRESSION INDUCTOR	CH-84
L117,L120	CHOKE, EMI	CH-57
L119,L121,L122,L123,L124	FERRITE CHIP 600 OHM BLM32A07	CH-62
L125	CHOKE, 100MHZ	CH-50
PS101	POWER SUPPLY DC-DC CONVERTER	PS-76-1A
Q101,Q102,Q104,Q119	TRANS, NPN, MMBT3904	TG-238
Q103	TRANS, PNP, MMBT3906L	TG-244
Q105,Q106	TRANS, N CHANNEL MOSFET, BUZ11	TG-211
Q107,Q108,Q109,Q110	HEXFET POWER MOSFET, IRFZ44N	TG-354

Table 6-1 (cont.)

Mother board parts list

Circuit designation	Description	Keithley part no.
Q111,Q116,Q117	TRANS, P-CHAN, MOSFET, TP0610T	TG-259
Q112,Q113,Q114,Q115,Q120,Q121,Q122,Q123	TRANS, N-MOSFET, VN0605T	TG-243
Q124,Q125,Q126,Q127	TRANS, N-MOSFET, VN0605T	TG-243
R101,R103,R104,R105,R188	RES, 10, 5%, 125MW METAL FILM	R-375-10
R102	RES, .02, 1.5W, 1%	R-468-.02
R107,R198,R200	RES, 20K, 1%, 100MW, THICK FILM	R-418-20K
R112,R113	RES, 200K, 1%, 125MW, METAL FILM	R-391-200K
R114,115,106,123,208,135,136,130,157,143	RES, 1K, 1%, 100MW, THICK FILM	R-418-1K
R116,R117,R150,R161,R162,R199,R209,R221	RES, 475, 1%, 100MW, THICK FILM	R-418-475
R119,R118,R141	RES, 30.1K, 1%, 100MW, THICK FILM	R-418-30.1K
R120,R142	RES, 24.3, 1%, 100MW, THICK FILM	R-418-24.3
R121	RES, 3.01K, 1%, 100MW, THICK FILM	R-418-3.01K
R122	RES, 1.74K, 1%, 100MW, THICK FILM	R-418-1.74K
R124,R126,R307	RES, .0499, 1%, 100MW, THICK FILM	R-418-.0499
R125,127,131,165,151,152,168,169,171	RES, 10K, 1%, 100MW, THICK FILM	R-418-10K
R132,R311	RES, 7.5K, 1%, 100MW, THICK FILM	R-418-7.5K
R133	RES, 51, 5%, 125MW, METAL FILM	R-375-51
R134,R137,R201,R306	RES, 200, 1%, 100MW, THICK FILM	R-418-200
R138,R139,R316	RES, 5.11K, 1%, 100MW, THICK FILM	R-418-5.11K
R146,147,167,177,178,202,216,217,218,219	RES, 1K, 1%, 100MW, THICK FILM	R-418-1K
R148,R149,R255,R256,R257,R279,R284,R140	RES, 2.21K, 1%, 100MW, THICK FILM	R-418-2.21K
R153	RES, 49.9K, 1%, 100MW, THICK FILM	R-418-49.9K
R154	RES, 1.28M, .1%, 1/8W, METAL FILM	R-176-1.28M
R159	RES, 4.99K, 1%, 125mW, METAL FILM	R-391-4.99K
R160	RES, 100K, 1%, 100MW, THICK FILM	R-418-100K
R163	RES, 2.49K, 1%, 125MW, METAL FILM	R-391-2.49K
R164	RES, 20K, .1%, 1/10W, METAL FILM	R-263-20K
R170	RES, 2.49K, .1%, .125MW, THIN FILM	R-456-2.49K
R172	RES, 10K, .1%, .125W, THIN FILM	R-456-10K
R173	RES, 249K, .1%, .125W, THIN FILM	R-456-249K
R174	RES, 27.7K, .1%, .125W, THIN FILM	R-456-27.7K
R175	RES, 10K, .1%, 1/10W, METAL FILM	R-263-10K

Table 6-1 (cont.)
Mother board parts list

Circuit designation	Description	Keithley part no.
R176	RES, 1K, .1%, 1/10W, METAL FILM	R-263-1K
R179	RES, 100K, .1%, 1/10W, METAL FILM	R-263-100K
R180	RES, 34K, 1%, 100MW, THICK FILM	R-418-34K
R181,R248,R254,R270	RES, 4.75K, 1%, 100MW, THICK FILM	R-418-4.75K
R182	RES, 82.5, 1%, 100MW, THICK FILM	R-418-82.5
R183,R293,R295,R297,R299,R301,R303	RES, 5.11K, 1%, 100MW, THICK FILM	R-418-5.11K
R184	RES, 470,5%, 125MW, METAL FILM	R-375-470
R185,189,239,294,296,298,300,302,304	RES, 100, 1%, 100MW, THICK FILM	R-418-100
R186	RES, 6.65K, .1%, 1/10W, METAL FILM	R-263-6.65K
R187	RES NET	TF-245
R190,R191,R192,R193,R194,R195,R196,R197	RES, 5.11K, 1%, 100MW, THICK FILM	R-418-5.11K
R203	RES, .1, 1%, 3W	R-475-.1
R210,R305,R313,R314,R315,R320	RES, 10K, 1%, 100MW, THICK FILM	R-418-10K
R211,R215,R252	RES, 10M, 1%, 125MW, THICK FILM	R-418-10M
R212	RES, 18K, .1%, 1/10W, METAL FILM	R-263-18K
R213,235,236,241-247,249-251,253,263-266	RES, 10K, 1%, 100MW, THICK FILM	R-418-10K
R214	RES, 3.2K, .1%, 1/10W, METAL FILM	R-263-3.2K
R220,222,230,231,258-262,267,272,280,281	RES, 1K, 1%, 100MW, THICK FILM	R-418-1K
R223,R224,R225,R226,R227,R228,R229,R232	RES, 475, 1%, 100MW, THICK FILM	R-418-475
R233,R234,R237	RES, 475, 1%, 100MW, THICK FILM	R-418-475
R238	RES, 15k, 1%, 100MW, THICK FILM	R-418-15K
R240	RES, 332K, 1%, 100MW, THICK FILM	R-418-332K
R268,R269,R271,R274-277,282,283,285-290	RES, 10K, 1%, 100MW, THICK FILM	R-418-10K
R273	RES, 100, 5%, 250MW, METAL FILM	R-376-100
R278	RES, 100, .1%, 1/10W, METAL FILM	R-263-100
R291,292,312,R158	RES, 1K, 1%, 100MW, THICK FILM	R-418-1K
R308	RES, .1%, 1/10W, METAL FILM	R-263-229
R309	RES, 56.2, .1%, 1/10W, METAL FILM	R-263-56.2
RV101	TRANSIENT VOLTAGE SUPPRESSOR	VR-25
SO-168	SOCKET PLCC-032-T-A	SO-143-32
T101	TRANSFORMER	TR-315A
TP103,TP104,TP111-TP113,TP118-TP120	SURFACE MOUNT PCB TEST POINT	CS-1026

Table 6-1 (cont.)*Mother board parts list*

Circuit designation	Description	Keithley part no.
TP121,TP122	SURFACE MOUNT PCB TEST POINT	CS-1026
U101	IC, +5V VOLTAGE REGULATOR, LM2940CT	IC-576
U102	IC, VOLTAGE REGULATOR	IC-1133
U103	IC, -15V VOLTAGE REGULATOR	IC-1135
U104	IC, VOLTAGE REGULATOR	IC-1132
U105,U119	IC, DUAL FET OPAMP	IC-1128
U107	IC, 80V 2.5A FULL BRIDGE FET DRIVER	IC-1139
U108,U109,U123	IC, 2 - INPUT AND GATE	IC-1140
U110	IC, HIGH SPEED PWM CONTROLLER	IC-1119
U113	IC, SUPPLY VOLT SUPERVISOR, TL7705A	IC-860
U114	IC, AJD SHUNT REGULATOR, TL431CLP	IC-677
U115,U150	IC, SINGLE TRANSISTOR OPTO COUPLER	IC-1182
U116	IC, HIGH SPEED PWN CONTROLLER	IC-1120
U118	IC, VOLT COMPARATOR LM393D	IC-775
U120,U124	IC, OPA177GS	IC-960
U121	IC, PRECISION BIFET OPAMP	IC-1194
U122	IC, DUAL BIPOLAR OP-AMP, LT1124CS8	IC-955
U125,U172	IC, VOLTAGE REFERENCE	IC-1065
U126,U130,U131,U152,U153	IC, CMOS ANAL SWITCH, DG444DY	IC-866
U127	IC, +5V 16 BIT DAC, MAX542ACSD	IC-1176
U128	IC, VOLT. COMPARATOR, LM311M	IC-776
U129	IC, OP-AMP, NE5534D	IC-802
U132	IC, +5V 10 BIT DAC, MAX515CSA	IC-1331
U133	IC, NCHAN LAT DMOS QUADFET, SD5400CY	IC-893
U134,U135,U136,U143	IC, 8 STAGE SHIFT C074HC409AM	IC-1026
U138	IC, QUAD D FLIP FLOP W/CLK, RESET 74HC175	IC-923
U139,U140	IC, QUAD 2 IN NOR, 74HCT02	IC-809
U141	IC, SERIAL EPROM 24LC16B	LSI-153
U142	IC, 8-CHAN ANA MULTIPLEXER, DG408DY	IC-844
U145	PROGRAM	2000-802A02
U146	IC, DUAL D-TYPE F/F, 74HC74	IC-773

Table 6-1 (cont.)
Mother board parts list

Circuit designation	Description	Keithley part no.
U147,U151	IC, DIFFERENTIAL AMP, INA117P	IC-889
U148	IC, OP-AMP, LOW NOISE LT1007CS8	IC-949
U149	IC, OPAMP	IC-1357
U155,U158,U154	IC, HCPL0631, PACK	IC-1153
U156,U157	IC, HIGH SPEED OPTO COUPLER	IC-1225
U159,U165	IC, POS NAND GATES/INVERT, 74HCT14	IC-656
U160	IC, 64KX16 BIT CMOS STATIC RAM	LSI-215-1
U161	IC, 2 INPUT EXCLUSIVE OR GATE, NC7SZ86	IC-1180
U163	IC, MICROCONTROLLER MC68332-FC	LSI-161
U164	IC, PROTECTED QUAD POWER DRIVERS	IC-1212
U166	IC, +5V RS-232 TRANSCEIVER, MAX202	IC-952
U167	IC, GPIB ADAPTER, 9914A	LSI-123
U168	PROGRAMMED ROM	2510-800*
U169	IC, OCTAL INTER BUS TRANS,75161	IC-647
U170	IC, OCTAL INTERFACE BUS, 75160	IC-646
U171,U137	IC, 2-INPUT OR GATE	IC-1206
U173	IC, CURRENT SOURCE, LM334H	IC-421
U174	IC, CENTIGRADE TEMP SENSOR, LM35DZ	IC-933
VR103,VR104	DIODE, ZENER, 6.2V MMSZ6V2	DZ-97
VR105	DIODE	DZ-127
VR106	DIODE, ZENER 30V BZX84C30	DZ-106-30
W101,W102	JUMPER, .300	J-7-1
Y101	OSCILLATOR HIGH SPEED CMOS 12MHZ	CR-37
Y102	CRYSTAL, FSM327	CR-41

*Order current firmware revision, for example 2510-800A01.

Table 6-2
Display board parts list

Circuit designation	Description	Keithley part no.
C901	CAP, 22UF, 20%, 6.3 TANTALUM	C-417-22
C902,C904,C907,C908,C910	CAP, .1UF, 20%,100V, CERAMIC	C-436-.1
C903,C905,C906,C909,C911	CAP, .1UF, 20%, 50V, CERAMIC	C-418-.1
C912	CAP, 2.2UF, 20%,100V, ALUM ELEC	C-503-2.2
C913,C914	CAP, 100UF, 20%, 16V, TANTALUM	C-504-100
C915,C916	CAP, 33PF, 10%, 100V, CERAMIC	C-451-33P
CR901,CR902,CR903,CR904	DIODE, SWITCHING, 250MA,BAV103	RF-89
CR905,CR906	DIODE, SWITCHING, MMBD914	RF-83
DS901	VACUUM FLUORESCENT DISPLAY	DD-51C
J1032	CONN, BERG	CS-339
J1033	CONN, HEADER STRAIGHT SOLDER PIN	CS-368-16
Q901,Q902	TRANS, NPN GEN PURPOSE BC868	TG-293
R901	RES NET, 15K, 2%, 1.875W	TF-219-15K
R902	RES, 13K, 5%,125MW, METAL FILM	R-375-13K
R903,R904	RES, 4.7K, 5%, 250MW, METAL FILM	R-376-4.7K
R905	RES, 1M, 5%, 125MW, METAL FILM	R-375-1M
R906	RES, 1K, 5%, 250MW, METAL FILM	R-376-1K
R907	RES, 240, 5%, 250MW, METAL FILM	R-376-240
R908	RES, 10M, 5%, 125MW, METAL FILM	R-375-10M
T901	TRANSFORMER, TDK, ER14.5 SERIES	TR-300
U901,U904,U905	IC, LATCHED DRIVERS, UCN-5812EPF-1	IC-732
U902	PROGRAMMED ROM	7001-800*
U903	IC, 32-BIT, SERIAL UCN5818EPF-1	IC-830
VR901	DIODE, ZENER, 8.2V, MMBZ5237	DZ-92
Y901	CRYSTAL, 4MHZ	CR-36-4M

*Order current revision level, for example 7001-800A02.

Table 6-3
Miscellaneous parts list

Qty.	Description	Keithley part no.
1	BEZEL, REAR	428-303D
1	CHASSIS	2510-301A
1	CONDUCTIVE RUBBER SWITCH	2510-315A
1	COVER	2510-307A
1	DISPLAY LENS	2510-311B
1	FAN	FN-39-1
2	FOOT	428-319A
2	FOOT, EXTRUDED	FE-22A
2	FOOT,RUBBER	FE-6
1	FUSE HOLDER	FH-39
1	FUSE, EXP. 2.5/5X20MM	FU-106-2.5
1	HANDLE	428-329F
1	LENS, LED	6517-309B
1	LINE CORD	CO-7
1	LINE MODULE	PM-1-1B
1	MATING INPUT/OUTPUT CONNECTOR	CS-846
1	MEMBRANE SWITCH, FRONT PANEL	6430-313A
1	MODIFIED FRONT PANEL	2510-308A
1	MOUNTING EAR, LEFT	428-338B
1	MOUNTING EAR, RIGHT	428-328E
1	OVERLAY FRONT PANEL	2510-309A
2	PC BOARD STOP	2001-371A
1	POWER ROD	2001-320A
1	POWER SUPPLY	PS-77-1A
1	REAR PANEL	2510-303A

LTR.	ECA NO.	REVISION	ENG.	DATE
A		PRELIMINARY	AJS	5/24/99
B		PRELIMINARY	CAD	9/2/99
C	23834	RELEASED	LM/CAD	12/1/99
D	23898	ADDED, DELETED, CHG'D PART REFER TO ECA FOR DETAILS	JBN	8/18/00
E	25768	ADDED J103 (NOT POPULATED)	MS	1/18/01
F	25747	ARTWORK WAS REV E. ADDED C500	TA/AS	02/23/02

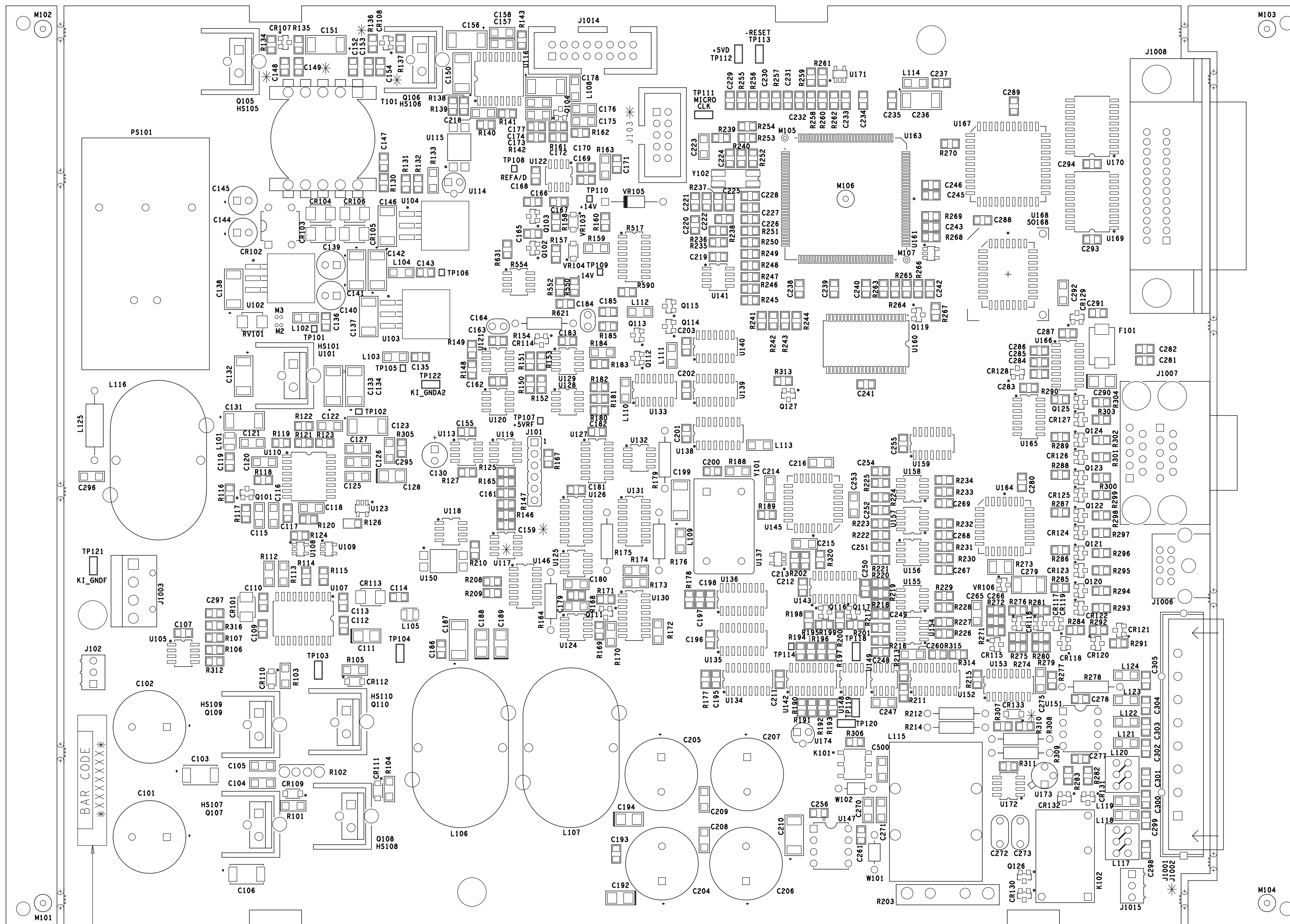

* DO NOT POPULATE:
 SMT: C148, C149, C153, C154,
 C159, R310, U117.
 PTH: J103, J1002.

NOTE:
 FOR FURTHER COMPONENT INFORMATION,
 REFER TO 2510 PRODUCT STRUCTURE.

MODEL	NEXT ASSEMBLY	QTY.

USED ON

KEITHLEY KEITHLEY INSTRUMENTS INC. CLEVELAND, OHIO 44139	DIM ARE IN IN. UNLESS OTHERWISE NOTED		DATE 5/21/99	SCALE 3:2	TITLE COMPONENT LAYOUT, MOTHER BOARD
	DIM. TOL. UNLESS OTHERWISE SPECIFIED		DRN AJS	APPR. ps	
XX=+.01 XXX=+.005	ANG.=+1 FRAC.=+1/64	DO NOT SCALE THIS DRAWING		C NO.	2510-100

2400-110 ON

LTR.	ECO NO.	REVISION	ENG.	DATE
A	17908	RELEASED	SZ	10-25-95
C	20811	CHG'D ARTWORK FROM REV A TO C.	SZ	1-29-98
D	24050	MOVED DISPLAY 20MILS INWARD.	LM/MS	2-05-99
E	26879	CHG'D ARTWORK FROM REV D TO E. ADDED C917 AND J1034. TO BE USED ON MODEL 2436 ONLY.	TA/MS AJS	02/02/02

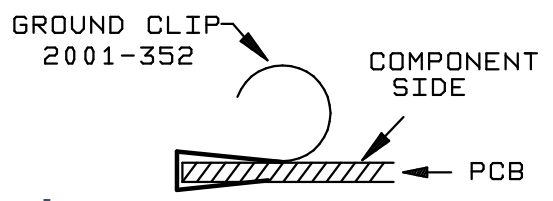
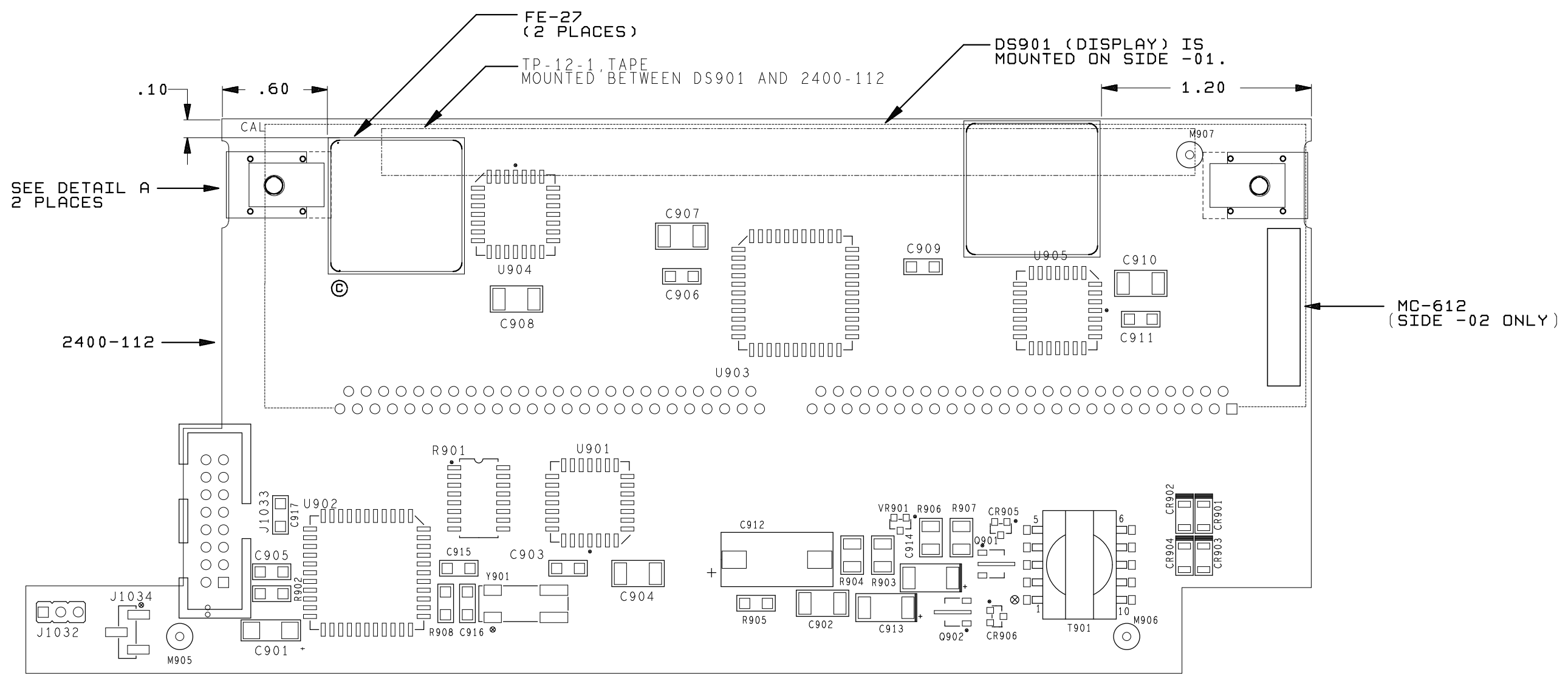

NOTE: FOR MORE COMPONENT INFORMATION REFER TO 2400 PRODUCT STRUCTURE.

MODEL	NEXT ASSEMBLY	QTY.
2400		1
USED ON		

DO NOT SCALE THIS DRAWING		DIMENSIONAL TOLERANCES UNLESS OTHERWISE SPECIFIED		DATE 6/22/95	SCALE 3:2	TITLE COMPONENT LAYOUT, DISPLAY BOARD	
KEITHLEY INSTRUMENTS INC. CLEVELAND, OHIO 44139		XX=±.010	ANG.=±1°	DRN. AJS	ENG. APPR. AJS	B	NO. 2400-110
		XXX=±.005	FRAC.=±1/64	MATERIAL	FINISH		
		SURFACE MAX. 63					

A Specifications

2510 TEC SourceMeter

The Model 2510 Thermoelectric Cooler Controller is designed to:

- control the power to the TEC to maintain a constant temperature, current, voltage, or thermistor resistance
- measure the resistance of the TEC
- software PID loop

CONTROL SYSTEM SPECIFICATIONS

SET: Constant Peltier Temperature
Constant Peltier Voltage
Constant Peltier Current
Constant Thermistor Resistance

CONTROL METHOD:

Programmable software PID loop.
Proportional, Integral, and Derivative gains independently programmable.

SETPOINT SHORT TERM STABILITY: $\pm 0.005^\circ\text{C rms}$.^{2,3}

SETPOINT LONG TERM STABILITY: $\pm 0.01^\circ\text{C}$.^{2,4}

SETPOINT RANGE: -50°C to 225°C .

OVER TEMPERATURE LIMIT: 250°C max .

UNDER TEMPERATURE LIMIT: -50°C max .

SETPOINT RESOLUTION: 0.001°C , 1mV , $100\mu\text{A}$, 0.01% of nominal (25°C) thermistor resistance.

HARDWARE CURRENT LIMIT: 1.0A to $5.25\text{A} \pm 5\%$.

SOFTWARE VOLTAGE LIMIT: ± 0.5 to $10.5\text{V} \pm 5\%$.

THERMAL FEEDBACK ELEMENT SPECIFICATIONS (1 Year, $23^\circ\text{C} \pm 5^\circ\text{C}$)

Sensor Type	RTD		Thermistor				Solid State	
	100 Ω	1 k Ω	100 Ω	1 k Ω	10 k Ω	100 k Ω	Current Output (I_{SS})	Voltage Output (V_{SS})
Excitation ⁹	2.50 mA	833 μA	2.5 mA	833 μA	100 μA	33 μA	+13.5V	2.5 mA
Compliance						833 $\mu\text{A max}$	833 μA	15.75 V max
Nominal Resistance Range	0–250 Ω	0–2.50 k Ω	0–1 k Ω	0–10 k Ω	0–80 k Ω	0–200 k Ω		
Excitation Accuracy	$\pm 2.9\%$	$\pm 2.9\%$	$\pm 2.9\%$	$\pm 2.9\%$	$\pm 2.9\%$	$\pm 2.9\%$	$\pm 12\%$	$\pm 2.9\%$
Nominal Sensor Temperature Range	-50° to $+250^\circ\text{C}$	-50° to $+250^\circ\text{C}$	-50° to $+250^\circ\text{C}$	-50° to $+250^\circ\text{C}$	-50° to $+250^\circ\text{C}$	-50° to $+250^\circ\text{C}$	-40° to $+100^\circ\text{C}$	-40° to $+100^\circ\text{C}$
Sensor Coefficients	α, β, δ	α, β, δ	A, B, C	A, B, C	A, B, C	A, B, C	Slope & offset	Slope & offset
Measurement Accuracy ($\pm\%$ rdg + offset)	$0.04 + 0.07 \Omega$	$0.04 + 0.4 \Omega$	$0.04 + 0.07 \Omega^1$	$0.04 + 0.4 \Omega^1$	$0.02 + 3 \Omega^1$	$0.04 + 21 \Omega$	$0.03 + 100 \text{ nA}$	$0.03 + 500 \mu\text{V}$

THERMISTOR MEASUREMENT ACCURACY¹⁴

Nominal Thermistor Resistance	Accuracy vs. Temperature			
	0 $^\circ\text{C}$	25 $^\circ\text{C}$	50 $^\circ\text{C}$	100 $^\circ\text{C}$
100 Ω	0.021 $^\circ\text{C}$	0.035 $^\circ\text{C}$	0.070 $^\circ\text{C}$	0.27 $^\circ\text{C}$
1 k Ω	0.015 $^\circ\text{C}$	0.023 $^\circ\text{C}$	0.045 $^\circ\text{C}$	0.18 $^\circ\text{C}$
10 k Ω	0.006 $^\circ\text{C}$	0.012 $^\circ\text{C}$	0.026 $^\circ\text{C}$	0.15 $^\circ\text{C}$
100 k Ω	0.009 $^\circ\text{C}$	0.014 $^\circ\text{C}$	0.026 $^\circ\text{C}$	0.13 $^\circ\text{C}$

TEC OUTPUT SPECIFICATIONS

OUTPUT RANGE: $\pm 10\text{VDC}$ at up to $\pm 5\text{ADC}$.

OUTPUT RIPPLE: $< 5\text{mV rms}$.⁵

AC RESISTANCE EXCITATION: $\pm(9.6\text{mA} + 190\mu\text{A})$.^{10,11}

TEC MEASUREMENT SPECIFICATIONS

FUNCTION	1 Year, $23^\circ\text{C} \pm 5^\circ\text{C}$
Operating Resistance ^{1,6,7,8}	$\pm(2.0\%$ of rdg + 0.1mV)
Operating Voltage ^{1,6}	$\pm(0.1\%$ of rdg + 4mV)
Operating Current ⁶	$\pm(0.4\%$ of rdg + 8mA)
AC Resistance ^{1,13}	$\pm(0.10\%$ of rdg + 0.02Ω)

OPEN SHORTED THERMOELECTRIC DETECTION

LOAD IMPEDANCE: Stable into $1\mu\text{F}$ typical.

COMMON MODE VOLTAGE: 30VDC maximum.

COMMON MODE ISOLATION: $> 10^6\Omega$, $< 1500\text{pF}$.

MAX. SENSE LEAD RESISTANCE: 1Ω for rated accuracy.

MAX. FORCE LEAD RESISTANCE: 0.1Ω .

OPEN/SHORTED ELEMENT DETECTION

SOFTWARE LINEARIZATION FOR THERMISTOR AND RTD

COMMON MODE VOLTAGE: 30VDC .

COMMON MODE ISOLATION: $> 10^6\Omega$, $< 1000\text{pF}$.

MAX. VOLTAGE DROP IN INPUT FORCE LEADS: 1 volt.

MAX. SENSE LEAD RESISTANCE: 100Ω for rated accuracy.

SENSE INPUT IMPEDANCE: $> 1 \cdot 10^6\Omega$.

GENERAL

NOISE REJECTION:

SPEED	NPLC	CMRR ¹²
Normal	1.00	90 dB

SOURCE OUTPUT MODES: Fixed DC level.

PROGRAMMABILITY: IEEE-488 (SCPI-1995.0), RS-232, 3 user-definable power-up states plus factory default and *RST.

POWER SUPPLY: Nominal 100 to 240VAC rms, 50–60Hz, 90VA.

WARRANTY: 1 year.

EMC: Conforms to European Union Directive 89/336/EEC, EN 61326-1.

SAFETY: Conforms to European Union Directive 73/23/EEC, EN 61010-1.

VIBRATION: MIL-PRF-28800F Class 3 Random Vibration.

WARM-UP: 1 hour to rated accuracies.

DIMENSIONS, WEIGHT: 89mm high \times 213 mm wide \times 370mm deep (3 1/2 in \times 8 3/8 in \times 14 1/8 in).
Basic configuration (with handle & feet): 104mm high \times 238mm wide \times 370mm deep (4 1/8 in \times 9 3/8 in \times 14 1/8 in).
Weight: 1.8 lbs.

ENVIRONMENT: Operating: 0° – 50°C , 70% R.H. up to 35°C . Derate 3% R.H./ $^\circ\text{C}$, 35° – 50°C .
Storage: -25° to 65°C .

NOTES

- 1 With remote voltage sense.
- 2 With 10k Ω thermistor as sensor.
- 3 Short term stability is defined as 24 hours with Peltier and Model 2510 at $25^\circ\text{C} \pm 0.5^\circ\text{C}$.
- 4 Long term stability is defined as 30 days with Peltier and Model 2510 at $25^\circ\text{C} \pm 0.5^\circ\text{C}$.
- 5 10Hz to 10MHz measured at 5A output into a 2 Ω load.
- 6 Common mode voltage = 0V (meter connect enabled, connects Peltier low output to thermistor measure circuit ground). $\pm(0.1\%$ of rdg + 0.1Ω) with meter connect disabled.
- 7 Resistance range 0Ω to 20Ω for rated accuracy.
- 8 Current through Peltier $> 0.2\text{A}$.
- 9 Default values shown, selectable values of 3 μA , 10 μA , 33 μA , 100 μA , 833 μA , 2.5mA. Note that temperature control performance will degrade at lower currents.
- 10 AC Ohms is a dual pulsed measurement using current reversals available over bus only.
- 11 @ $23^\circ\text{C} \pm 5^\circ\text{C}$.
- 12 For 1k Ω unbalance in LO lead. Minimum amplifier specification.
- 13 Resistance range 0Ω to 100Ω for rated accuracy.
- 14 Accuracy figures represent the uncertainty that the Model 2510 may add to the temperature measurement, not including thermistor uncertainty. These accuracy figures are for thermistors with typical A, B, C constants.

Accuracy calculations

The information below discusses how to calculate accuracy for both TEC measurement and thermal feedback element specifications.

Accuracy specifications are stated as follows:

$$\text{Accuracy} = \pm(\% \text{ of reading} + \text{offset})$$

As an example of how to calculate the actual limits, assume an output voltage of 5V. You can compute the limits from one-year operating voltage accuracy specifications as follows:

$$\begin{aligned} \text{Accuracy} = & \pm(\% \text{ of reading} + \text{offset}) \\ & \pm[(0.1\% \times 5\text{V}) + 4\text{mV}] \\ & \pm(5\text{mV} + 4\text{mV}) \\ & \pm 9\text{mV} \end{aligned}$$

Thus, the actual operating voltage range is: $5\text{V} \pm 9\text{mV}$, or from 4.991 to 5.009V.

B Calibration Reference

Introduction

This appendix contains detailed information on the various Model 2510 remote calibration commands, calibration error messages, and methods to detect the end of each calibration step.

Section 2 of this manual covers detailed calibration procedures.

Command summary

Table B-1 summarizes Model 2510 calibration commands. These commands are covered in detail in the following paragraphs.

Table B-1
Calibration commands

Command	Description
:CALibration	Calibration subsystem.
:PROTeCted	Calibration commands protected by code/password.
:CODE '<password>'	Unlock calibration. (Default code/password: KI002510.)
:CODE?	Query calibration code/password.
:SENSe	
:VOLTage <NRf>	Calibrate Peltier voltage measurement.
:DATA?	Query Peltier voltage calibration constants.
:CURRent <NRf>	Calibrate current measurement.
:DATA?	Query current calibration constants.
:TEMPerature <NRf>	Calibrate temperature measurement.
:DATA?	Query temperature calibration constants.
:SOURce <NRf>	Calibrate Peltier source/sense voltage.
:DATA?	Query Peltier source/sense calibration constants.
:AUTO	Calibrate voltage source.
:IPDac	Calibrate current protection DAC.
:DATA?	Query current protection DAC calibration constants.
:RESistance	
[:AC] <NRf>	Calibrate AC ohms.
:DATA?	Query AC ohms calibration constants
:DATE <yyyy>,<mm>,<dd>	Program calibration year, month, day.
:DATE?	Query calibration date.
:NDUE <yyyy>,<mm>,<dd>	Program calibration due year, month, day.
:NDUE?	Query calibration due date.
:SAVE	Save calibration data in EEPROM.
:LOCK	Lock out calibration.
:LOCK?	Query if calibration is locked. (1 = locked; 0 = unlocked).
:COUNt?	Query number of times Model 2510 has been calibrated.

Miscellaneous commands

Miscellaneous commands are those commands that perform such functions as unlocking calibration, saving calibration constants, locking out calibration, and programming date parameters.

:CODE

(:CALibration:PROTECTED:CODE)

Purpose	To unlock calibration so that you can perform the calibration procedures.
Format	:cal:prot:code '<password>'
Parameters	Up to a 8-character string including letters and numbers.
Description	The :CODE command sends the password/code and enables calibration when performing these procedures via remote. The correct password must be sent to the unit before sending any other calibration command. The default remote password is KI002510.

- NOTE**
- *The :CODE command should be sent only once before performing calibration. Do not send :CODE before each calibration step.*
 - *To change the code, first send the present code, then send the new code.*
 - *The password parameter must be enclosed in single quotes.*
 - *If you change the first two characters of the password to something other than "KI", you will not be able to unlock calibration from the front panel.*

Example :CAL:PROT:CODE 'KI002510' Send default code of KI002510.

:COUNT?

(:CALibration:PROTECTED:COUNT?)

Purpose	To request the number of times the Model 2510 has been calibrated.
Format	:cal:prot:count?
Response	Number of times calibrated.
Description	The :COUNT? query may be used to determine the total number of times the Model 2510 has been calibrated.
Example	:CAL:PROT:COUNT? Request calibration count.

:LOCK

(:CALibration:PROTeCted:LOCK)

Purpose	To lock out calibration.	
Format	:cal:prot:lock	
Query	:cal:prot:lock?	
Response	0	Calibration unlocked
	1	Calibration locked
Description	The :LOCK command allows you to lock out calibration after completing the procedure. Thus, :LOCK performs the opposite of sending the password with the :CODE command. The :LOCK? query returns calibration lock status.	

NOTE To unlock calibration, send the :CODE command with the appropriate password.

Example :CAL:PROT:LOCK Lock out calibration

:SAVE

(:CALibration:PROTeCted:SAVE)

Purpose	To save calibration constants in EEROM after the calibration procedure.	
Format	:cal:prot:save	
Description	The :SAVE command stores internally calculated calibration constants derived during comprehensive in EEROM. EEROM is non-volatile memory, and calibration constants will be retained indefinitely once saved. Generally, :SAVE is sent after all other calibration steps (except for :LOCK).	

NOTE Calibration will be only temporary unless the :SAVE command is sent to permanently store calibration constants. Calibration data will not be saved if calibration was not unlocked by sending the :CODE command or if invalid calibration data exists.

Example :CAL:PROT:SAVE Save calibration constants

:DATE

(:CALibration:PROTECTED:DATE)

Purpose To program the calibration date.**Format** :cal:prot:date <year>, <month>, <day>**Parameters** <year> = 2000 to 2099
<month> = 1 to 12
<day> = 1 to 31**Query** :cal:prot:date?**Response** <year>, <month>, <day>**Description** The :DATE command allows you to store the calibration date in instrument EEROM for future reference. You can read back the date from the instrument by using the :DATE? query, or by using the front panel CAL menu.*NOTE* The year, month, and day parameters must be delimited by commas.**Example** :CAL:PROT:DATE 2000,11,20 Send cal date (11/20/2000).**:NDUE**

(:CALibration:PROTECTED:NDUE)

Purpose To send the next calibration due date to the instrument.**Format** :cal:prot:ndue <year>, <month>, <day>**Parameters** <year> = 2000 to 2099
<month> = 1 to 12
<day> = 1 to 31**Query** :cal:prot:ndue?**Response** <year>, <month>, <day>**Description** The :NDUE command allows you to store the date when calibration is next due in instrument memory. You can read back the next due date by using the :NDUE? query, or by using the front panel CAL menu.*NOTE* The next due date parameters must be delimited by commas.**Example** :CAL:PROT:NDUE 2001,11,20 Send due date (11/20/2001).

SENSe commands

:VOLTage

(:CALibration:PROTected:SENSe:VOLTage)

(:CALibration:PROTected:SENSe:VOLTage:DATA?)

Purpose To calibrate the Peltier voltage measurement.

Format :cal:prot:sens:volt <DMM_Reading>

Parameters <DMM_Reading> = 3.5 to 12.5[V] = cal at + F.S.
 -2.5 to 2.5[V] = zero cal
 -3.5 to -12.5[V] = cal at - F.S.

Query :cal:prot:sens:volt:data?

Description The :CAL:PROT:SENS:VOLT command calibrates the Model 2510 Peltier voltage measurement. During the calibration process, this command is sent three times; once each with parameters of approximately +F.S, 0, and -F.S. The actual parameters are voltage readings taken with a precision DMM. The :CAL:PROT:SENS:VOLT:DATA? query allows you to request the Peltier voltage calibration parameters.

Example :CAL:PROT:SENS:VOLT 8.51 Calibrate positive voltage.

:CURRent

(:CALibration:PROTected:SENSe:CURRent)

(:CALibration:PROTected:SENSe:CURRent:DATA?)

Purpose To calibrate the current measurement.

Format :cal:prot:sens:curr <Resistor_Value>

Parameters <Resistor_Value> = 0.5 to 1.5[Ω]

Query :cal:prot:sens:curr:data?

Description The :CAL:PROT:SENS:CURR command calibrates the Model 2510 current measurement. During the calibration process, a 1Ω (nominal) resistor must be connected to the OUTPUT terminals, and the source is automatically set to +4.5V, 0V, and -4.5V. The command parameter is the characterized value of the 1Ω resistor.

The :CAL:PROT:SENS:CURR:DATA? query allows you request the current calibration parameters.

Example :CAL:PROT:SENS:CURR 1.01 Calibrate current.

:TEMPerature

(:CALibration:PROTected:SENSe:TEMPerature)

(:CALibration:PROTected:SENSe:TEMPerature:DATA?)

Purpose To calibrate the temperature sensor measurements.**Format** :cal:prot:sens:temp <Value>

Parameters <Resistor_Value> = 100k Ω thermistor: 0 to 125e3[Ω]
 10k Ω thermistor: 0 to 12.5e3[Ω]
 1k Ω thermistor: 0 to 1.25e3[Ω]
 100 Ω thermistor: 0 to 125[Ω]
 100 Ω RTD: 0 to 125[Ω]
 1000 Ω RTD: 0 to 1250 [Ω]
 VSS: 0V to 5[V]
 ISS: 350 to 1.25e3[Ω] then 0.01 to 1.5[V]

Query :cal:prot:sens:temp:data?

Description The :CAL:PROT:SENS:TEMP command calibrates the Model 2510 temperature sensor measurements. During the calibration process, a 100 Ω , 1k Ω , 10k Ω , or 100k Ω (nominal) resistor or a short must be connected to the INPUT terminals, and the characterized value, a zero value, or a voltage reading is sent as the command parameter, depending on the calibration step (see Section 2 for details). The appropriate sensor and range must first be selected with the following commands:

- Enable 4-wire sensing: :SYST:RSEN ON
- Thermistor sensor: :SENS:TEMP:TRAN THER
- Thermistor range: :SENS:TEMP:THER:RANG <Range>
- RTD sensor: :SENS:TEMP:TRAN RTD
- RTD range: :SENS:TEMP:RTD:RANG <Range>
- ISS sensor: :SENS:TEMP:TRAN ISS
- VSS sensor: :SENS:TEMP:TRAN VSS

The :CAL:PROT:SENS:TEMP:DATA? query allows you request the temperature sensor calibration parameters.

Example :CAL:PROT:SENS:TEMP 100.5 Calibrate temperature sensor.

SOURce commands

:SOURCE

(:CALibration:PROTeCted:SOURce)

(:CALibration:PROTeCted:SOURce:DATA?)

Purpose To calibrate the Peltier source/sense voltage.

Format :cal:prot:sour <DMM_Reading>

Parameters <DMM_Reading> = 3.5 to 12.5[V] = cal at + F.S.
 -2.5 to 2.5[V] = zero cal
 -3.5 to -12.5[V] = cal at - F.S.

Query :cal:prot:sour:data?

Description The :CAL:PROT:SOUR command calibrates the Model 2510 Peltier source/sense voltage. During the calibration process, this command is sent three times; once each with parameters of approximately +F.S (full scale), 0, and -F.S. The actual parameters are voltage readings taken with a precision DMM.

The :CAL:PROT:SOUR:DATA? query allows you request the voltage calibration parameters.

Example :CAL:PROT:SOUR 8.51 Calibrate with positive voltage.

:AUTO

(:CALibration:PROTeCted:SOURce:AUTO)

Purpose To calibrate the voltage source.

Format :cal:prot:sour:auto

Description The :CAL:PROT:SOUR:AUTO command calibrates the Model 2510 voltage source. Disconnect all test leads or equipment from the OUTPUT terminals before sending this command.

Example :CAL:PROT:SOUR:AUTO Calibrate voltage source.

DAC commands

:IPDac

(:CALibration:PROTeCted:IPDac)

(:CALibration:PROTeCted:IPDac:DATA?)

Purpose To calibrate the current protection DAC.

Format :cal:prot:ipd

Query :cal:prot:ipd:data?

Description The :CAL:PROT:IPD command calibrates the current protection DAC. A resistor of less than 1.5Ω must be connected to the OUTPUT terminals before this command is sent.

The :CAL:PROT:IPD:DATA? query allows you request the current protection DAC calibration parameters.

Example :CAL:PROT:IPD Calibrate current protection DAC.

RESistance commands

:RESistance

(:CALibration:PROTeCted:RESistance[:AC])

(:CALibration:PROTeCted:RESistance[:AC]:DATA?)

Purpose To calibrate the AC ohms circuit.

Format :cal:prot:res <Resistance_Value>

Parameters <Resistance_Value> = 10 to 1e3 [Ω] (100 default)

Query :cal:prot:res:data?

Description The :CAL:PROT:RES command calibrates the Model 2510 AC ohms circuit. A 10Ω to 1kΩ (100Ω preferred) resistor must be connected to the OUTPUT terminals, and the characterized value of that resistor is used as the :CAL:PROT:RES command parameter. The output is off.

The :CAL:PROT:RES:DATA? query requests the AC ohms calibration constants.

Example :CAL:PROT:RES 99.5 Calibrate with 100Ω nominal resistor.

Detecting calibration errors

If an error occurs during any calibration step, the Model 2510 will generate an appropriate error message. Several methods to detect calibration errors are discussed below.

Reading the error queue

As with other Model 2510 errors, any calibration errors will be reported in the error queue. (You can read the error queue by using the `:SYST:ERR?` query.)

Error summary

Table B-2 summarizes calibration errors. If errors occur, and `:CAL:PROT:SAVE` is sent, calibration constants without errors will be saved while those with errors will not.

Status byte EAV (Error Available) bit

Whenever an error is available in the error queue, the EAV (Error Available) bit (bit 2) of the status byte will be set. Use the `*STB?` query to obtain the status byte, then test bit 2 to see if it is set. If the EAV bit is set, an error has occurred, and you can use the appropriate error query to read the error and at the same time clear the EAV bit in the status byte.

Generating an SRQ on error

To program the instrument to generate an IEEE-488 bus SRQ (Service Request) when an error occurs, send the following command: `*SRE 4`. This command will enable SRQ when the EAV bit is set. You can then read the status byte and error queue as outlined above to check for errors and to determine the exact nature of the error.

Table B-2
Calibration errors

Error number	Error message
+500	"Date of calibration not set"
+501	"Next date of calibration not set"
+502	"Calibration data invalid"
+509	"Not permitted with cal locked"
+510	"Not permitted with cal un-locked"
+520	"Source + gain data invalid"
+521	"Source + offset data invalid"
+522	"Source - gain data invalid"
+523	"Source - offset data invalid"
+524	"Source DAC Overflow"
+525	"Source DAC Underflow"
+530	"I Protection gain data invalid"
+531	"I Protection offset data invalid"
+532	"I Protection DAC Overflow"
+533	"I Protection DAC Underflow"
+540	"V Meas + gain data invalid"
+541	"V Meas + offset data invalid"
+542	"V Meas - gain data invalid"
+543	"V Meas - offset data invalid"
+550	"I Meas + gain data invalid"
+551	"I Meas + offset data invalid"
+552	"I Meas - gain data invalid"
+553	"I Meas - offset data invalid"
+560	"100 Ohm Thermistor data invalid"
+561	"1kOhm Thermistor data invalid"
+562	"10kOhm Thermistor data invalid"
+563	"100kOhm Thermistor data invalid"
+564	"RTD data invalid"
+565	"VSS data invalid"
+566	"ISS data invalid"
+570	"AC Ohms data invalid"

Detecting calibration step completion

When sending remote calibration commands, you must wait until the instrument completes the current operation before sending another command. You can use either `*OPC?` or `*OPC` to help determine when each calibration step is completed.

Using the `*OPC?` query

With the `*OPC?` (operation complete) query, the instrument will place an ASCII 1 in the output queue when it has completed each step. To determine when the OPC response is ready, do the following:

1. Repeatedly test the MAV (Message Available) bit (bit 4) in the status byte and wait until it is set. (You can request the status byte by using the `*STB?` query.)
2. When MAV is set, a message is available in the output queue, and you can read the output queue and test for an ASCII 1.
3. After reading the output queue, repeatedly test MAV again until it clears. At this point, the calibration step is completed.

Using the `*OPC` command

The `*OPC` (operation complete) command can be used to detect the completion of each calibration step. In order to use `*OPC` to detect the end of each calibration step, do the following:

1. Enable operation complete by sending `*ESE 1`. This command sets the OPC (operation complete bit) in the standard event enable register, allowing operation complete status from the standard event status register to set the ESB (event summary bit) in the status byte when operation complete is detected.
2. Send the `*OPC` command immediately following each calibration command. For example:

```
:CAL:PROT:SENS:VOLT 8;*OPC
```

Note that you must include the semicolon (;) to separate the two commands, and that the `*OPC` command must appear on the same line as the calibration command.

3. After sending a calibration command, repeatedly test the ESB (Event Summary) bit (bit 5) in the status byte until it is set. (Use `*STB?` to request the status byte.)
4. Once operation complete has been detected, clear OPC status using one of two methods: (1) use the `*ESR?` query, then read the response to clear the standard event status register, or (2) send the `*CLS` command to clear the status registers. Note that sending `*CLS` will also clear the error queue and operation complete status.

Generating an SRQ on calibration complete

An IEEE-488 bus SRQ (service request) can be used to detect operation complete instead of repeatedly polling the Model 2510. To use this method, send both *ESE 1 and *SRE 32 to the instrument, then include the *OPC command at the end of each calibration command line, as covered above. Clear the SRQ by querying the ESR (using the *ESR? query) to clear OPC status, then request the status byte with the *STB? query.

Refer to your controller's documentation for information on detecting and servicing SRQs.

C Calibration Program

Introduction

This appendix includes a calibration program written in BASIC to help you to calibrate the Model 2510. Refer to Section 2 for more details on calibration procedures, equipment, and connections. Appendix B covers calibration commands in detail.

Computer hardware requirements

The following computer hardware is required to run the calibration programs:

- IBM PC compatible computer.
- Keithley KPC-488.2, KPS-488.2, or KPC-488.2AT, or CEC PC-488 IEEE-488 interface for the computer.
- Two shielded IEEE-488 connecting cables (Keithley Model 7007).

Software requirements

In order to use the calibration programs, you will need the following computer software:

- Microsoft QBasic (supplied with MS-DOS 5.0 or later) or Quick Basic.
- MS-DOS version 5.0 or later or Windows 95/98/Me.
- HP-style Universal Language Driver, CECHP.EXE (supplied with Keithley and CEC interface cards listed above).

Calibration equipment

The following calibration equipment is required:

- Keithley Model 2002 DMM.
- 1 Ω , 100 Ω , 1k Ω , 10k Ω , and 100k Ω resistors.
- Clean copper wire.

See Section 2 for detailed equipment specifications.

General program instructions

1. With the power off, connect the Model 2510 and the digital multimeter to the IEEE-488 interface of the computer. Be sure to use shielded IEEE-488 cables for bus connections.
2. Turn on the computer, the Model 2510, and the digital multimeter. Allow the Model 2510 and the multimeter to warm up for at least one hour before performing calibration.
3. Make sure the Model 2510 is set for a primary address of 15. (Use the front panel MENU/COMMUNICATIONS/GPIB selection to check or change the address.)
4. Make sure the digital multimeter primary address is set to 16.
5. Make sure that the computer bus driver software (CECHP.EXE) is properly initialized.
6. Enter the QBasic editor, and type in the program below.

NOTE Be sure to change the resistor parameters (R\$, R\$(1) - R\$(4)) to the characterized values of the 1 Ω , 100 Ω , 1k Ω , 10k Ω , and 100k Ω resistors. (See Section 2 for details.)

7. Check thoroughly for errors, then save it using a convenient filename.
8. Run the program, and follow the prompts on the screen to perform calibration. For test connections, refer to the following figures in Section 2:
 - Voltage calibration DMM connections: Figure 2-1.
 - Current and current protection calibration 1 Ω resistor connections: Figure 2-2.
 - Thermistor and RTD calibration 100 Ω to 100k Ω resistor connections: Figure 2-3.
 - Shorted INPUT connections: Figure 2-4.
 - I-SS and V-SS calibration resistor/DMM connections: Figure 2-5.
 - AC ohms calibration 100 Ω resistor connections: Figure 2-6.

Program C-1 Model 2510 calibration program

```

\ Model 2510 calibration program for use with Keithley 2002 DMM.
\ 2510 primary address = 15. 2002 primary address = 16.
OPEN "IEEE" FOR OUTPUT AS #1          \ Open IEEE-488 output path.
OPEN "IEEE" FOR INPUT AS #2          \ Open IEEE-488 input path.
PRINT #1, "INTERM CR LF"             \ Set input terminator.
PRINT #1, "OUTTERM LF"               \ Set output terminator.
PRINT #1, "REMOTE 15 16"             \ Put 2510, 2002 in remote.
PRINT #1, "OUTPUT 15;*RST"           \ Initialize 2510.
PRINT #1, "OUTPUT 15;*CLS"           \ Clear 2510 status.
PRINT #1, "OUTPUT 15;*ESE 1;*SRE 32" \ Enable OPC and SRQ.
PRINT #1, "OUTPUT 16;:SYST:PRES"     \ Initialize 2002.
PRINT #1, "OUTPUT 16;:FORM:ELEM READ" \ 2002 reading data only.
\
\ Replace nominal resistor values below with characterized values.
R$ = "1"                             \ 1 ohm value.
R$(1) = "100"                         \ 100 ohm value.
R$(2) = "1e3"                          \ 1k ohm value
R$(3) = "1e4"                          \ 10k ohm value.
R$(4) = "1e5"                          \ 100k ohm value.
\
CLS
PRINT "Model 2510 Calibration Program"
GOSUB KeyCheck
PRINT #1, "OUTPUT 15;:CAL:PROT:CODE 'KI002510'"
J = 1
FOR I = 1 TO 46
READ Cmd$
SELECT CASE I
CASE 1
PRINT "Connect DMM INPUT to 2510 OUTPUT terminals."
GOSUB KeyCheck
CASE 3, 4, 6, 7, 9, 10, 39, 41
GOSUB ReadDMM
Cmd$ = Cmd$ + Reading$
CASE 12
PRINT "Connect 1 ohm resistor to OUTPUT terminals."
GOSUB KeyCheck
CASE 13
Cmd$ = Cmd$ + R$
CASE 19, 22, 25, 28, 32, 35
IF I = 32 THEN J = 1
PRINT "Connect "; R$(J); " ohm resistor to INPUT terminals."
GOSUB KeyCheck
Cmd$ = Cmd$ + R$(J)
J = J + 1

```

```

CASE 20, 23, 26, 29, 33, 36, 42
    PRINT "Short INPUT terminals with clean copper wire."
    PRINT "Wait 1 minute."
    GOSUB KeyCheck
CASE 38, 41
    PRINT "Connect 1k ohm resistor and DMM to INPUT terminals."
    IF I = 38 THEN Cmd$ = Cmd$ + R$(2)
    GOSUB KeyCheck
CASE 43
    PRINT "Connect 100 ohm resistor to OUTPUT terminals."
    GOSUB KeyCheck
    Cmd$ = Cmd$ + R$(1)
CASE 44
    PRINT "Disconnect all equipment from OUTPUT terminals."
    GOSUB KeyCheck
END SELECT
PRINT #1, "OUTPUT 15;"; Cmd$; ";*OPC"
GOSUB CalEnd
GOSUB ErrCheck
NEXT I
LINE INPUT "Enter calibration date (yyyy,mm,dd): "; D$
PRINT #1, "OUTPUT 15;:CAL:PROT:DATE "; D$
LINE INPUT "Enter calibration due date (yyyy,mm,dd): "; D$
PRINT #1, "OUTPUT 15;:CAL:PROT:NDUE "; D$
PRINT #1, "OUTPUT 15;:CAL:PROT:SAVE"      ` Save calibration constants.
GOSUB ErrCheck
PRINT #1, "OUTPUT 15;:CAL:PROT:LOCK"      ` Lock out calibration.
PRINT "Calibration completed."
PRINT #1, "LOCAL 15 16"
CLOSE
END
\
KeyCheck:                                ` Check for key press routine.
WHILE INKEY$ <> "" : WEND                  ` Flush keyboard buffer.
PRINT : PRINT "Press any key to continue (ESC to abort program)."
```

DO: I\$ = INKEY\$: LOOP WHILE I\$ = ""

```

IF I$ = CHR$(27) THEN GOTO EndProg        ` Abort if ESC is pressed.
RETURN
\
CalEnd:                                    ` Check for cal step completion.
DO: PRINT #1, "SRQ?"                       ` Request SRQ status.
    INPUT #2, S                             ` Input SRQ status byte.
LOOP UNTIL S                               ` Wait for operation complete.
PRINT #1, "OUTPUT 15;*ESR?"               ` Clear OPC.
PRINT #1, "ENT # 15"
INPUT #2, S
PRINT #1, "SPOLL 15"                       ` Clear SRQ.
INPUT #2, S
RETURN
```

```

\
ErrCheck:                                ` Error check routine.
PRINT #1, "OUTPUT 15;:SYST:ERR?"         ` Query error queue.
PRINT #1, "ENTER 15"
INPUT #2, E, Err$
IF E <> 0 THEN PRINT Err$: GOTO ErrCheck' Display error.
RETURN
\
ReadDMM:                                  ` Get reading from DMM.
SLEEP 3
PRINT #1, "OUTPUT 16;:READ?"
PRINT #1, "ENTER 16"
INPUT #2, Reading$
RETURN
\
EndProg:                                  ` Close files, end program.
BEEP: PRINT "Calibration aborted."
PRINT #1, "OUTPUT 15;:CAL:PROT:LOCK"
PRINT #1, "OUTPUT 15;*RST"
PRINT #1, "LOCAL 15 16"
CLOSE
END
\
CmdList:                                  ` Calibration command list.
DATA ":OUTP ON",":SOUR:VOLT 8.5","CAL:PROT:SENS:VOLT ","CAL:PROT:SOUR "
DATA ":SOUR:VOLT 0","CAL:PROT:SENS:VOLT ","CAL:PROT:SOUR "
DATA ":SOUR:VOLT -8.5","CAL:PROT:SENS:VOLT ","CAL:PROT:SOUR ","OUTP OFF"
DATA ":OUTP ON", "CAL:PROT:SENS:CURR ","CAL:PROT:IPD","OUTP OFF"
DATA ":SYST:RSEN ON","SENS:TEMP:TRAN THER"
DATA ":SENS:TEMP:THER:RANG 100","CAL:PROT:SENS:TEMP ","CAL:PROT:SENS:TEMP 0"
DATA ":SENS:TEMP:THER:RANG 1E3","CAL:PROT:SENS:TEMP ","CAL:PROT:SENS:TEMP 0"
DATA ":SENS:TEMP:THER:RANG 1E4","CAL:PROT:SENS:TEMP ","CAL:PROT:SENS:TEMP 0"
DATA ":SENS:TEMP:THER:RANG 1E5","CAL:PROT:SENS:TEMP ","CAL:PROT:SENS:TEMP 0"
DATA ":SENS:TEMP:TRAN RTD","SENS:TEMP:RTD:RANG 100"
DATA ":CAL:PROT:SENS:TEMP ","CAL:PROT:SENS:TEMP 0"
DATA ":SENS:TEMP:RTD:RANG 1E3","CAL:PROT:SENS:TEMP ","CAL:PROT:SENS:TEMP 0"
DATA ":SENS:TEMP:TRAN ISS","CAL:PROT:SENS:TEMP ","CAL:PROT:SENS:TEMP "
DATA ":SENS:TEMP:TRAN VSS","CAL:PROT:SENS:TEMP ","CAL:PROT:SENS:TEMP 0"
DATA ":CAL:PROT:RES ","OUTP ON"
DATA ":CAL:PROT:SOUR:AUTO","OUTP OFF"

```

Index

A

- Aborting calibration steps 2-8
- AC resistance accuracy 1-10
- Accuracy calculations A-5
- Analog circuitry checks 4-17
- Assembly drawings 5-3

B

- Block diagram
 - Analog circuitry 4-6
 - Digital circuitry 4-13
 - Overall 4-5
 - Power supply 4-12

C

- Calibration 2-1
- Calibration commands B-2
- Calibration considerations 2-3
 - Calibration cycle 2-3
 - Recommended calibration equipment 2-3
 - Resistor characterization 2-4
- Calibration equipment C-2
- Calibration errors 2-7, B-11
 - Front panel error reporting 2-7
 - Remote error reporting 2-7
- Calibration menu 2-5
- Calibration Program C-1
- Calibration Reference B-1
- Calibration step summary 2-9
- Case cover removal 5-4
- Changing the password 2-6
 - by remote 2-6
 - from the front panel 2-6
- Characterized resistor values 1-4, 2-4
- Class D Amplifier 4-6
- Command summary B-2
- Component layouts 6-2
- Computer hardware requirements C-2

Connections

- AC ohms calibration 2-18
- Current and current protection calibration 2-11
 - for AC resistance verification test 1-11
 - for current verification tests 1-9
 - for sensor resistance accuracy verification 1-12
 - for voltage verification tests 1-7
- I-SS and V-SS calibration resistor 2-15
- Shorted input calibration 2-13
- Thermistor and RTD calibration resistor 2-12
 - voltage calibration 2-9

Current accuracy 1-8

- limit 1-10
- Output 1-8
- readback 1-9

D

- DAC commands B-9
 - :IPDac B-9
- Detecting calibration errors B-10
 - Error summary B-10
 - Generating an SRQ on error B-10
 - Reading the error queue B-10
 - Status byte EAV (Error Available) bit B-10
- Detecting calibration step completion B-12
 - Generating an SRQ on calibration complete B-13
 - Using the *OPC command B-12
 - Using the *OPC? query B-12
- Digital circuitry checks 4-18
- Disassembly 5-1
- Display board checks 4-15

E

- Environmental conditions 2-2
 - Line power 2-2
 - Temperature and relative humidity 2-2
 - Warm-up period 2-2

F

- Factory service 6-2
- Front panel calibration 2-8
- Front panel disassembly 5-5
- Front panel tests 4-3
 - CHAR SET test 4-4
 - DISPLAY PATTERNS test 4-4
 - KEYS test 4-3
- Fuse replacement
 - Digital I/O +5V supply 4-18
 - Power supply module 4-17

G

- General program instructions C-3
 - Program C-1 Model 2510 calibration program C-4

H

- Handling and cleaning 5-2
 - Handling PC boards 5-2
 - Solder repairs 5-2
- H-Bridge 4-8

I

- Instrument reassembly 5-6
- Internal fuse replacement 4-17
- Introduction 1-2, 2-2, 3-2, 4-2, 5-2, 6-2, B-2, C-2

L

- Line fuse replacement 3-2

M

- Miscellaneous commands B-3
 - :CODE B-3
 - :COUNT? B-3
 - :DATE B-5
 - :LOCK B-4
 - :NDUE B-5
 - :SAVE B-4
- Mother board removal 5-4

N

- No comm link error 4-18

O

- Ordering information 6-2

P

- Parts list
 - Display board 6-9
 - Miscellaneous 6-10
 - Mother board 6-3
- Parts lists 6-2
- Performance Verification 1-1
- Performing the verification test procedures 1-5
 - Adjusting setpoints 1-6
 - Test considerations 1-6
 - Test summary 1-5
- PID hardware loop control 4-11
- Power line fuse 3-3
- Power supply checks 4-16
- Power-on self-test 4-3
- Principles of operation 4-5
 - Analog circuits 4-6
 - A/D converter 4-11
 - Measurement circuits 4-10
 - Source circuits 4-6
 - Digital circuitry 4-13
 - Display board circuits 4-15
 - Overall block diagram 4-5
 - Power supply 4-12

R

- Rear panel 3-2
- Recommended calibration equipment 2-4
- Recommended test equipment 1-3
 - Resistor characterization 1-4
- Recommended verification equipment 1-3
- Remote calibration 2-20
 - command summary 2-20
 - procedure 2-21
- Remote calibration command summary 2-20
- Removing power components 5-5
 - Fan removal 5-6
 - Power module removal 5-6
 - Power supply module removal 5-5
- Repair considerations 4-2
- Replaceable Parts 6-1
- Resetting the calibration password 2-7
- RESistance commands B-9
 - :RESistance B-9
- Restoring factory defaults 1-5
- Routine Maintenance 3-1

S

- Safety considerations 4-2
- SENSE commands B-6
 - :CURRENT B-6
 - :TEMPerature B-7
 - :VOLTage B-6
- Sensor conditioning 4-10
- Sensor measurement accuracy 1-11
- Sensor resistance measurement accuracy limits 1-13
- Software requirements C-2
- SOURce commands B-8
 - :AUTO B-8
 - :SOURCE B-8
- Specifications A-1
- Static sensitive devices 5-3

T

- Troubleshooting 4-1, 4-15
 - Analog circuitry checks 4-17
 - Digital circuitry checks 4-16
 - Display board checks 4-15
 - Power supply checks 4-16

U

- Unlocking calibration 2-5
 - by remote 2-6
 - from the front panel 2-5

V

- Verification limits 1-4
 - Example limits calculation 1-4
 - Resistance limits calculation 1-4
- Verification test requirements 1-2
 - Environmental conditions 1-2
 - Line power 1-3
 - Warm-up period 1-2
- Viewing calibration dates and calibration count 2-7
- Voltage accuracy 1-6
 - limit 1-8
 - Output 1-6
 - readback 1-7



Service Form

Model No. _____ Serial No. _____ Date _____

Name and Telephone No. _____

Company _____

List all control settings, describe problem and check boxes that apply to problem. _____

Intermittent Analog output follows display Particular range or function bad; specify _____

IEEE failure Obvious problem on power-up Batteries and fuses are OK

Front panel operational All ranges or functions are bad Checked all cables

Display or output (check one)

Drifts Unable to zero Unstable

Overload Will not read applied input

Calibration only Certificate of calibration required Data required

(attach any additional sheets as necessary)

Show a block diagram of your measurement including all instruments connected (whether power is turned on or not). Also, describe signal source.

Where is the measurement being performed? (factory, controlled laboratory, out-of-doors, etc.) _____

What power line voltage is used? _____ Ambient temperature? _____ °F

Relative humidity? _____ Other? _____

Any additional information. (If special modifications have been made by the user, please describe.)

Be sure to include your name and phone number on this service form.

Specifications are subject to change without notice.

All Keithley trademarks and trade names are the property of Keithley Instruments, Inc. All other trademarks and trade names are the property of their respective companies.



Keithley Instruments, Inc.

28775 Aurora Road • Cleveland, Ohio 44139 • 440-248-0400 • Fax: 440-248-6168
1-888-KEITHLEY (534-8453) • www.keithley.com

Sales Offices: BELGIUM:

Bergensesteenweg 709 • B-1600 Sint-Pieters-Leeuw • 02-363 00 40 • Fax: 02/363 00 64

CHINA:

Yuan Chen Xin Building, Room 705 • 12 Yumin Road, Dewai, Madian • Beijing 100029 • 8610-6202-2886 • Fax: 8610-6202-2892

FINLAND:

Tietäjäsentie 2 • 02130 Espoo • Phone: 09-54 75 08 10 • Fax: 09-25 10 51 00

FRANCE:

3, allée des Garays • 91127 Palaiseau Cédex • 01-64 53 20 20 • Fax: 01-60 11 77 26

GERMANY:

Landsberger Strasse 65 • 82110 Germering • 089/84 93 07-40 • Fax: 089/84 93 07-34

GREAT BRITAIN:

Unit 2 Commerce Park, Brunel Road • Theale • Berkshire RG7 4AB • 0118 929 7500 • Fax: 0118 929 7519

INDIA:

Flat 2B, Willocrissa • 14, Rest House Crescent • Bangalore 560 001 • 91-80-509-1320/21 • Fax: 91-80-509-1322

ITALY:

Viale San Gimignano, 38 • 20146 Milano • 02-48 39 16 01 • Fax: 02-48 30 22 74

JAPAN:

New Pier Takeshiba North Tower 13F • 11-1, Kaigan 1-chome • Minato-ku, Tokyo 105-0022 • 81-3-5733-7555 • Fax: 81-3-5733-7556

KOREA:

2FL., URI Building • 2-14 Yangjae-Dong • Seocho-Gu, Seoul 137-888 • 82-2-574-7778 • Fax: 82-2-574-7838

NETHERLANDS:

Postbus 559 • 4200 AN Gorinchem • 0183-635333 • Fax: 0183-630821

SWEDEN:

c/o Regus Business Centre • Frosundaviks Allé 15, 4tr • 169 70 Solna • 08-509 04 679 • Fax: 08-655 26 10

SWITZERLAND:

Kriesbachstrasse 4 • 8600 Dübendorf • 01-821 94 44 • Fax: 01-820 30 81

TAIWAN:

1FL., 85 Po Ai Street • Hsinchu, Taiwan, R.O.C. • 886-3-572-9077 • Fax: 886-3-572-9031

© Copyright 2001 Keithley Instruments, Inc.

Printed in the U.S.A.

4/02