

# Model 247 High Voltage Supply

Instruction Manual

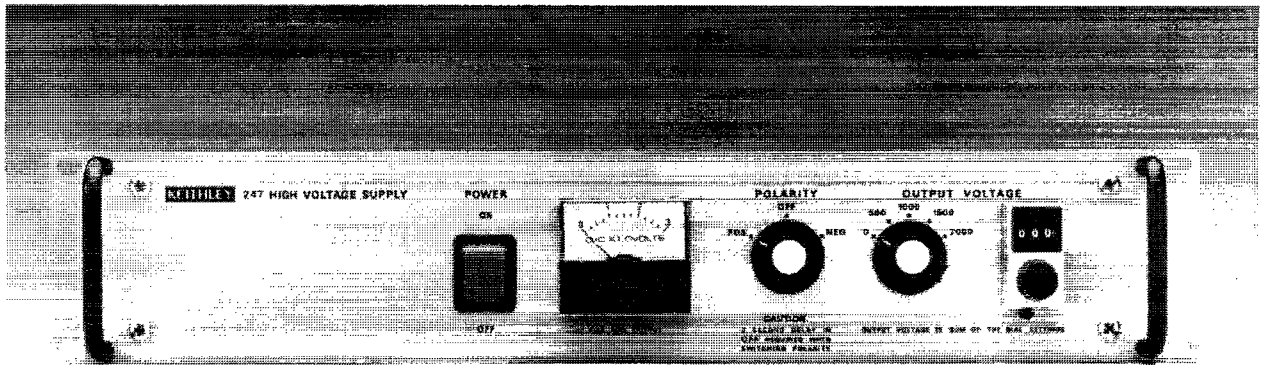

Contains Operating and Servicing Information

**KEITHLEY**

# WARRANTY

Keithley Instruments, Inc. warrants this product to be free from defects in material and workmanship for a period of 1 year from date of shipment.

Keithley Instruments, Inc. warrants the following items for 90 days from the date of shipment: probes, cables, rechargeable batteries, diskettes, and documentation.

During the warranty period, we will, at our option, either repair or replace any product that proves to be defective.

To exercise this warranty, write or call your local Keithley representative, or contact Keithley headquarters in Cleveland, Ohio. You will be given prompt assistance and return instructions. Send the product, transportation prepaid, to the indicated service facility. Repairs will be made and the product returned, transportation prepaid. Repaired or replaced products are warranted for the balance of the original warranty period, or at least 90 days.

## LIMITATION OF WARRANTY

This warranty does not apply to defects resulting from product modification without Keithley's express written consent, or misuse of any product or part. This warranty also does not apply to fuses, software, non-rechargeable batteries, damage from battery leakage, or problems arising from normal wear or failure to follow instructions.

THIS WARRANTY IS IN LIEU OF ALL OTHER WARRANTIES, EXPRESSED OR IMPLIED, INCLUDING ANY IMPLIED WARRANTY OF MERCHANTABILITY OR FITNESS FOR A PARTICULAR USE. THE REMEDIES PROVIDED HEREIN ARE BUYER'S SOLE AND EXCLUSIVE REMEDIES.

NEITHER KEITHLEY INSTRUMENTS, INC. NOR ANY OF ITS EMPLOYEES SHALL BE LIABLE FOR ANY DIRECT, INDIRECT, SPECIAL, INCIDENTAL OR CONSEQUENTIAL DAMAGES ARISING OUT OF THE USE OF ITS INSTRUMENTS AND SOFTWARE EVEN IF KEITHLEY INSTRUMENTS, INC., HAS BEEN ADVISED IN ADVANCE OF THE POSSIBILITY OF SUCH DAMAGES. SUCH EXCLUDED DAMAGES SHALL INCLUDE, BUT ARE NOT LIMITED TO: COSTS OF REMOVAL AND INSTALLATION, LOSSES SUSTAINED AS THE RESULT OF INJURY TO ANY PERSON, OR DAMAGE TO PROPERTY.



Test Instrumentation Group, Keithley Instruments, Inc. • 28775 Aurora Road • Cleveland, Ohio 44139 • (216) 248-0400 • Fax: (216) 248-6168

CHINA: Keithley Instruments, Inc. • Holiday Inn Lido • Office Building 404C • Beijing, China, 100004 • 8610-436-2871/2860 • 8610-436-2871

FRANCE: Keithley Instruments SARL • 3 Allée des Garays • B.P. 60 • 91122 Palaiseau Cédex • 01-60-11-51-55 • Fax: 01-60-11-77-26

GERMANY: Keithley Instruments GmbH • Landsberger Str. 65 • 82110 Germering • 089-849307-0 • Fax: 089-84930759

GREAT BRITAIN: Keithley Instruments, Ltd. • The Minster • 58 Portman Road • Reading, Berkshire RG30 1EA • 01734-575666 • Fax: 01734-596469

ITALY: Keithley Instruments SRL • Viale S. Gimignano 38 • 20146 Milano • 02-48303008 • Fax: 02-48302274

JAPAN: Keithley Instruments Far East KK • Sumiyoshi 24 Bldg., Room 201 • 2-24-2 Sumiyoshi-cho • Naka-ku, Yokohama 231 • 81-45-201-2246 • Fax: 81-45-201-2247

NETHERLANDS: Keithley Instruments BV • Avelingen West 49 • 4202 MS Gorinchem • Postbus 559 • 4200 AN Gorinchem • 01830-35333 • Fax: 01830-30821

SWITZERLAND: Keithley Instruments SA • Kriesbachstrasse 4 • 8600 Dübendorf • 01-821-9444 • Fax: 01-820-3081

# Model 247 High Voltage Supply Instruction Manual

© 1990, Keithley Instruments, Inc.  
Test Instrumentation Group  
All rights reserved.  
Cleveland, Ohio, U.S.A.  
December 1992, Sixth Printing  
Document Number: 31834 Rev. F

All Keithley product names are trademarks or registered trademarks of Keithley Instruments, Inc.

Other brand and product names are trademarks or registered trademarks of their respective holders.

# SAFETY PRECAUTIONS

The following safety precautions should be observed before using Model 247 High Voltage Supply.

The Model 247 High Voltage Supply is intended for use by qualified personnel who recognize shock hazards and are familiar with the safety precautions required to avoid possible injury. Read over the instruction manual carefully before using the instrument.

Exercise extreme caution when a shock hazard is present. Lethal voltages may be present on the test fixture or the supply output connector. The American National Standards Institute (ANSI) states the a shock hazard exists when voltage levels greater than 30V RMS or 42.4V peak are present. **A good safety practice is to expect that hazardous voltage is present in any unknown circuit before measuring.**

Inspect the connecting cables, test leads, and jumpers for possible wear, cracks, or breaks before each use.

For maximum safety, do not touch the voltage supply, test fixture, test cables or any other instruments while power is applied to the circuit under test. Turn off all power and discharge any capacitors before connecting or disconnecting cables or jumpers.

Do not touch any object which could provide a current path to the common side of the circuit under test or power line (earth) ground. Always make measurements with dry hands while standing on a dry, insulated surface capable of withstanding the voltage being measured.

Instrumentation and accessories should not be connected to humans.

The  symbol on a Model 247 indicates that 1000V or more may be present on the terminals. Refer to the Model 247 Instruction Manual.

# Model 247

## High Voltage Power Supply

### OUTPUT:

**Voltage:** 0 to 3kV DC.

**Current:** 6mA DC maximum.

**Polarity:** Positive or negative with respect to chassis.

**ACCURACY:** (18°-28°C):  $\pm$  (0.25% of setting + 1.5V DC) from 1% to 100% of maximum output voltage.

**RESOLUTION:** Dial graduations of 200mV.

**STABILITY:**  $\pm$ 0.01% of setting/hr.;  $\pm$ 0.02% of setting/8 hrs., at constant temperature after ½-hour warm-up.

**TEMPERATURE COEFFICIENT** (0°-18°C & 28°-50°C):  $\pm$ 50ppm/°C.

**LINE REGULATION:** 0.001% voltage change for 10% line variation.

**LOAD REGULATION:** 0.005% voltage change from no load to full load.

**RIPPLE AND NOISE:** 3.5mV rms, 10mV p-p @ 3kV, 6mA; 1mV rms, 3mV p-p @ 1kV, 1mA, 10Hz-100kHz.

**SETTLING TIME:** 4 seconds to within 1V with full resistive load.

**OVERLOAD PROTECTION:** Short circuit proof, arc protected, self restoring.

**METER:** Monitors voltage output.

### ENVIRONMENT:

**Operating:** 0° to 50°C, 0 to 80% relative humidity up to 35°C.

**Storage:** -40° to 75°C.

**CONNECTOR:** Rear panel, MHV Type UG-931/U.

**POWER:** 90-125V/180-250V, 50-60Hz, 130VA.

**DIMENSIONS, WEIGHT:** 483mm wide  $\times$  89mm high  $\times$  273mm deep (19 in.  $\times$  3½ in.  $\times$  10¾ in.), excluding handles. Four holes spaced for rack mounting. Net weight 5.9kg (13 lbs.).

**ACCESSORIES SUPPLIED:** Instruction manual, UG-932/U mating connector, mounting feet for bench operation.

Specifications subject to change without notice.

# Table of Contents

## SECTION 1 — General Information

1.1	PURPOSE OF EQUIPMENT .....	1-1
1.2	DESCRIPTION .....	1-1
1.3	SPECIFICATIONS .....	1-1
1.4	SAFETY SYMBOLS AND TERMS .....	1-1
1.5	WARRANTY INFORMATION .....	1-2

## SECTION 2 — Operation

2.1	INSTALLATION .....	2-1
2.2	FRONT PANEL CONTROLS AND TERMINALS .....	2-1
2.3	REAR PANEL CONNECTORS AND TERMINALS .....	2-2
2.4	PREPARATION FOR USE .....	2-3
2.5	INPUT POWER .....	2-3
2.6	CURRENT LIMITING .....	2-3
2.7	HIGH VOLTAGE OUTPUT .....	2-3
2.8	APPLICATIONS .....	2-4
2.8.1	Application of 247 with Photomultipliers .....	2-4
2.8.2	Application of 247 to Resistivity Measurements .....	2-4
2.8.3	Application of 247 with Ionization Chambers .....	2-4

## SECTION 3 — Theory of Operation

3.1	FUNCTIONAL DESCRIPTION .....	3-1
3.2	CIRCUIT DESCRIPTION .....	3-1

## SECTION 4 — Maintenance

4.1	INTRODUCTION .....	4-1
4.2	RECOMMENDED TEST EQUIPMENT .....	4-1
4.3	PREPARATION FOR MEASUREMENTS .....	4-2
4.4	CALIBRATION ADJUSTMENTS .....	4-2
4.5	PERFORMANCE TESTS .....	4-2
4.6	TROUBLESHOOTING PROCEDURE .....	4-3

## SECTION 5 — Replaceable Parts

5.1	INTRODUCTION .....	5-1
5.2	ORDERING INFORMATION .....	5-1
5.3	FACTORY SERVICE .....	5-1

# List of Tables

## SECTION 4 — Maintenance

Table 4-1	Recommended Test Equipment .....	4-1
-----------	----------------------------------	-----



# List of Illustrations

## SECTION 2 — Operation

Figure 2-1	Model 247 Front Panel .....	2-2
Figure 2-2	Model 247 Rear Panel .....	2-2
Figure 2-3	Connector and Cable Assembly .....	2-4
Figure 2-4	Photomultiplier Circuit .....	2-4
Figure 2-5	Resistivity Measurement .....	2-4
Figure 2-6	Ionization Chamber Circuit .....	2-4

## SECTION 3 — Theory of Operation

Figure 3-1	High Voltage Power Supply Block Diagram .....	3-1
------------	---	-----

## SECTION 4 — Maintenance

Figure 4-1	Model 247 Exploded View .....	4-4
------------	-------------------------------	-----

# SECTION 1

## General Information

---

---

### 1.1 PURPOSE OF EQUIPMENT

The Model 247 is a regulated precision laboratory high voltage power supply. It provides the low noise, excellent line regulation and high stability that are essential for the most rigid measurement requirements.

### 1.2 DESCRIPTION

The Model 247 is a precision regulated linear power supply with a maximum output voltage of 3kV. The units consist of a DC power supply which converts the AC line power to a low DC voltage and a DC converter which generates the high DC output voltage. Low voltage electronic solid-state circuitry is mounted on the plug-in PCB 100, and the high voltage assembly is fully encapsulated for reliable, arc-free, operation.

This stable, low noise high voltage power supply features front panel digital voltage metering and calibrated direct reading front panel controls, and a polarity selector switch. The rear panel features a HV output connector line power plug, fuse, and a voltage selector switch. The unit is arc and short circuit protected for safe, reliable operation.

The unit is fully enclosed and designed to mount in a standard 19" rack. The unit may also be used in benchtop applications using the rubber feet supplied.

### 1.3 SPECIFICATIONS

For Model 247 detailed specifications, refer to the specifications that precede this section.

### 1.4 SAFETY SYMBOLS AND TERMS

Safety symbols used in this manual are as follows:

The symbol  on the instrument denotes that the user should refer to the operating instructions.

The symbol  on the instrument denotes that 1000V or more may be present on the terminal(s).

The **WARNING** used in this manual explains dangers that could result in personal injury or death.

The **CAUTION** used in this manual explains hazards that could damage the instrument.

## 1.5 WARRANTY INFORMATION

The warranty is given on the inside front cover of this Instruction Manual. If there is a need to exercise the Warranty, contact the factory to determine the proper action to be taken.

### NOTE

Attempting to repair or tampering with the unit while still under warranty (less than 12 months since date of shipment) will void the warranty. All in-warranty repairs should be sent to the factory.

# SECTION 2

## Operation

---

---

### 2.1 INSTALLATION

#### WARNING

This unit outputs hazardous voltage that could cause injury or death. Do not connect to line power unless ground (GND) and output high are properly connected.

Figure 2-1 shows the mounting and clearance dimensions as well as the controls and connectors on the front and rear panels. Rubber feet and screws are supplied with each unit. For benchtop use, remove the four corner screws and install the four rubber feet using the new screws.

### 2.2 FRONT PANEL CONTROLS AND TERMINALS

**Power Switch** — A rocker switch turns the line power on or off to the entire instrument. The rocker switch has a built-in pilot lamp that is lit when the power switch is on.

**Output Meter** — The output meter monitors the output voltage. Meter operation is independent of the AC input power; therefore, it reads the output at all times.

**Polarity Switch** — The polarity switch sets the output for positive or negative polarity. Also, it switches the output voltage off.

#### CAUTION

A two-second delay in the center OFF position is required when switching polarity.

**Voltage Switch** — The Voltage switch sets the output voltage in increments of 500V from 0V to 2000V.

**Voltage Dial** — The Voltage dial is a 10 turn digital dial that supplements the Voltage switch setting by up to 1000V.

#### WARNING

Before turning the power on to the instrument, make sure the voltage switch and dial are properly set. Monitor the output on the meter when the power is on.

#### NOTE

The output voltage is the sum of the Voltage dial and the Voltage switch.

### 2.3 REAR PANEL CONNECTORS AND TERMINALS

**GND** — The case ground screw (GND) is to be connected to the measurement system common.

**Output Connector** — The output connector is a MHV type UG931/U connector. It mates with a MHV type UG932/U connector.

**Fuse** — The line power fuse (Slo-Blo) is rated 1.6A, 250V for 90-127V AC operation and 0.8A, 250V for 180-254V AC operation.

**Line Voltage Selector** — The line voltage selector selects the appropriate line voltage 90-127V AC or 180-254V AC.

**Line Plug** — The recessed line plug accepts a three-wire female line plug for line power.

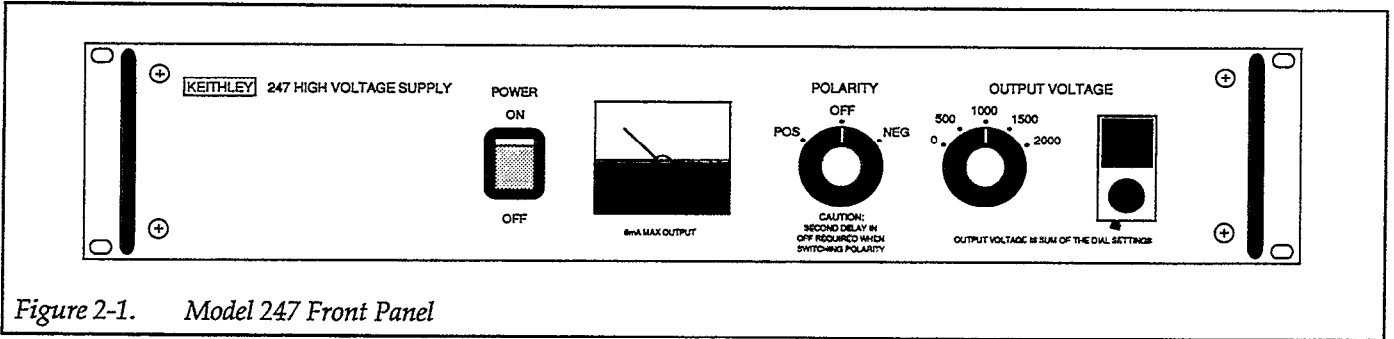

Figure 2-1. Model 247 Front Panel

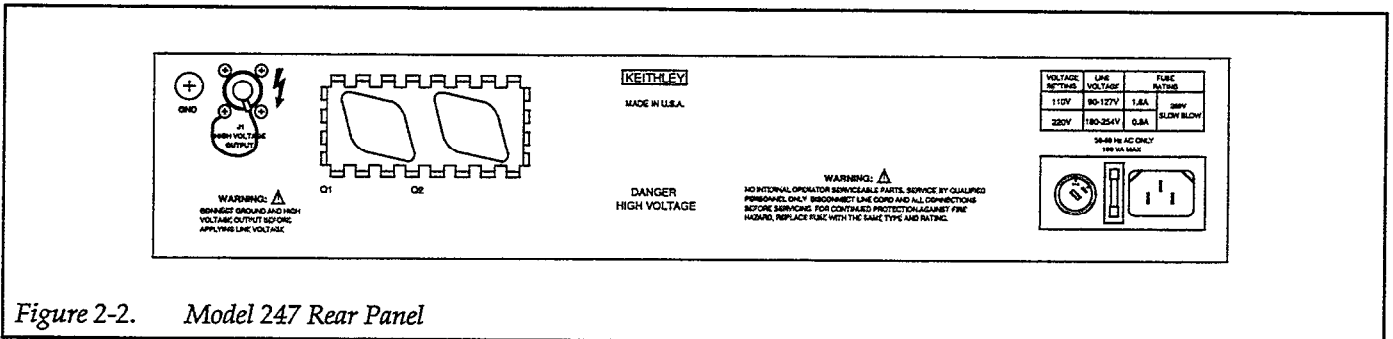

Figure 2-2. Model 247 Rear Panel

## 2.4 PREPARATION FOR USE

Perform the following procedure to prepare the Model 247 for use:

1. Set the Model 247 for proper line voltage operation as specified in paragraph 2.5.
2. Connect a ground wire from case ground (on rear panel) to the measuring system common.
3. Set the front panel controls to:
  - A. Power switch — OFF
  - B. Polarity switch — OFF
  - C. Output voltage switch — 0
  - D. 10 turn digital dial — 000 (full counterclockwise)
4. Plug the line cord into the power line with a three-wire receptacle to maintain proper case ground.

### WARNING

This unit is equipped with a three-wire grounded line cord. This must be used with a three-wire receptacle where the "third wire" is connected to earth ground, otherwise personal injury or death may occur.

5. Connect the output of the Model 247 to the circuit. Use a properly rated coaxial cable with the supplied MHV type UG932/U mating connector to insure good circuit connections and safe operation. Refer to paragraph 2.6.
6. Set the Polarity switch to the desired polarity.
7. Turn on the power to the instrument. With actual load and output voltage, allow one hour for warm up.
8. Increase the Voltage switch slowly to reach the approximate desired voltage. Then trim the voltage with the Voltage dial until the desired voltage level is obtained.

### WARNING

Always turn power OFF and verify that the Model 247's output meter reads 0V DC, before connecting or removing any equipment. External circuits may retain High Voltage after the Model 247 has been turned off. Discharge any residual voltage before connecting or removing any equipment.

## 2.5 INPUT POWER

The AC input line voltage required to operate the instrument is 90-127V or 180-254V. The recessed line voltage se-

lector switch on the rear panel selects either 90-127V (110V setting) or 180-254V (220V setting) operation.

The line fuse ratings are as follows:

Line Voltage	Fuse Rating	Keithley Part No.
90-127VAC	1.6A, 250V, slow blow 5 × 20mm	FU-96-7
180-254VAC	0.8A, 250V, slow blow, 5 × 20mm	FU-96-6

## 2.6 CURRENT LIMITING

The Model 247 includes a current limiting circuit that automatically drops the output voltage to a safe level when the rated output current is exceeded by 20%. Refer to the Maximum Current specification when operating the unit at reduced output voltages or when operating in a current limit mode for capacitor charging.

## 2.7 HIGH VOLTAGE OUTPUT

The high voltage output connector is located on the rear panel (output LO is connected to chassis). A MHV type UG932/U shielded mating connector is supplied with each unit. Assembly instructions for the connector are listed below.

1. Gently cut through the outer insulation without cutting the shield.
2. Using a sharp point, unravel the shield braid.
3. Clean off all traces of graphite.
4. Cut the center insulation to the proper length (approximately 3/8"). Cut the center conductor to approximately 1/8".
5. Solder center conductor to male pin. Cut the braid back so it fits around the connector (see Figure 2-3).
6. Assemble as in Figure 2-3.

### WARNING

When the High Voltage Output is not in use, turn off the power and cover the output connector with the supplied cover cap.

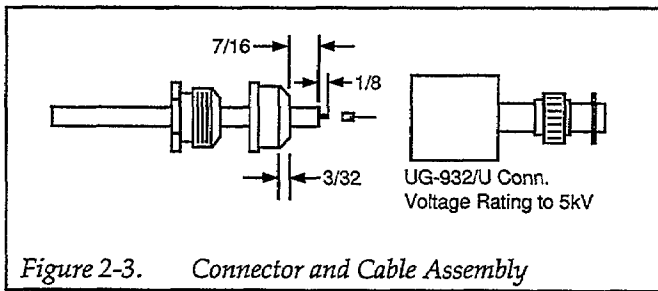

Figure 2-3. Connector and Cable Assembly

## 2.8 APPLICATIONS

The following are four examples of typical applications of the Model 247, related to the low current capabilities of electrometers and picoammeters.

### 2.8.1 Application of 247 with Photomultipliers

The electron-multiplier requires up to 200 volts per stage and may have 10 to 14 stages. Thus, a total supply voltage up to 3000V may be needed. The overall sensitivity or gain is very responsive to changes in supply voltage. For this reason the long-term stability of the supply must be excellent. The specified stability of the Model 247 is valid after one-hour warm up. Warm up takes one hour with actual load and output voltage.

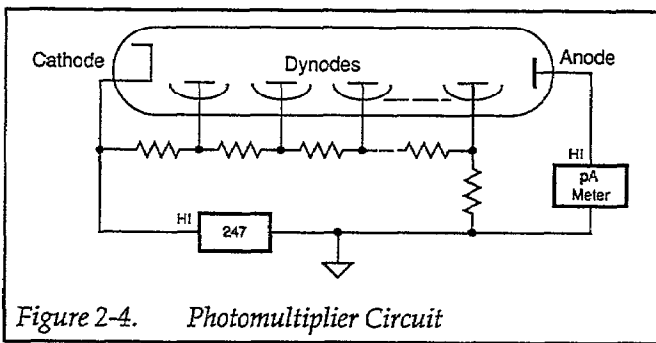

Figure 2-4. Photomultiplier Circuit

### 2.8.2 Application of 247 to Resistivity Measurements

To find resistivity of insulating materials, a known voltage is applied to a sample of the material. The resulting current is measured with a picoammeter or electrometer. With a source voltage of 1000 volts or more, higher resis-

tance materials may be measured. Flexible materials such as PVC, rubber or paper may be tested with the Model 6105 Resistivity Adapter as shown.

The Model 247 is especially useful since it is low-noise and well-regulated, allowing the more sensitive electrometer ranges to be used when measuring high quality insulators. The front panel polarity switch makes it easy to check for non-linearity (polarity sensitivity).

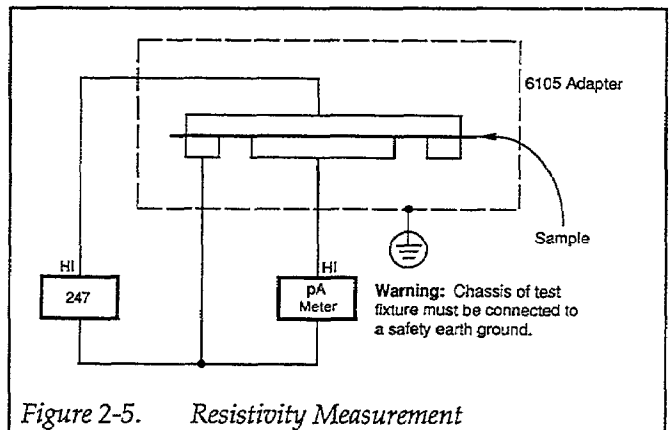

Figure 2-5. Resistivity Measurement

### 2.8.3 Application of 247 with Ionization Chambers

The electrodes must have a bias voltage of several hundred volts to enable them to collect ions. This voltage must be very steady since fluctuations would be capacitively coupled to the picoammeter and cause spurious readings. The excellent line and load stabilities of the Model 247 easily meet this need.

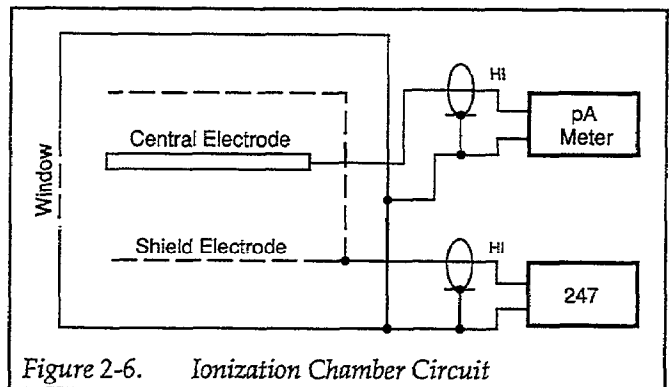

Figure 2-6. Ionization Chamber Circuit

# SECTION 3

## Theory of Operation

---

---

### 3.1 FUNCTIONAL DESCRIPTION

Figure 3-1 is a block diagram of the Model 247. The schematic diagram is located in Section 5, Replaceable Parts. When reading through the Theory of Operation for the Model 247, it will be helpful to refer to the schematic diagram.

The circuit uses a DC-DC converter which converts low voltage DC power to a high voltage DC output. This output voltage is highly regulated and filtered and can be varied by the front panel controls. The input to the DC-DC converter is obtained from internal low voltage power supplies powered by AC line input.

An oscillator determines the high frequency (approximately 20kHz) at which all amplification high voltage transformation, rectification and filtering occurs. The amplification is a function of a control voltage which performs the function of control and regulation. A sample of the output voltage is compared against a reference voltage in the sensing circuit. The sensing circuit generates the control voltage to set and maintain a fixed high voltage output.

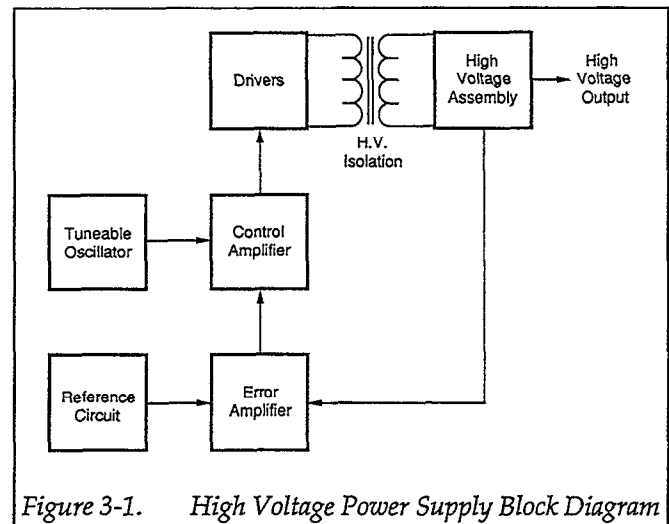

Figure 3-1. High Voltage Power Supply Block Diagram

### 3.2 CIRCUIT DESCRIPTION

The AC input line is converted to the B+ (36VDC) supply and regulated  $\pm 12V$  low voltage power supplies. The B+ supply is a filtered full wave rectifier circuit located on the chassis. The regulated low voltage power supply circuit (+12V) consists of a rectifier circuit located on T1 and output regulators located on PCB-100.

The output of the oscillator circuit which is amplified in the AGC amplifier, is a function of the control voltage developed at the output of the error amplifier.



The encapsulated high voltage assembly includes a high voltage transformer, rectifier or multiplier circuits, ripple filter and sensing circuit. These are all critical custom designed and encapsulated components.

A sample of the high voltage DC output is fed to the output voltage sensing circuit, and is compared to a com-

mand voltage. Output voltage control is obtained by varying the command voltage fed to the error amplifier. The error amplifier compares the command voltage and the signal from the output voltage sense circuit. Any differences causes a correction in the gain control of the AGC amplifier. The command voltage is controlled by the front panel controls. The reference and reference control and buffer provide a stable -5VDC to the front panel output voltage controls.

# SECTION 4

## Maintenance

---

---

### 4.1 INTRODUCTION

Section 4 contains information required for the maintenance of Model 247 units. It is organized around the verification procedure used to determine that the equipment is operating to specifications.

#### WARNING

The procedures in this section are for use only by qualified service personnel. Do not perform these procedures unless qualified to do so. Many of the steps in this section may expose you to potentially lethal voltages that could result in personal injury or

death if normal safety precautions are not observed.

#### WARNING

To prevent a shock hazard, remove the line cord and all test leads from the instrument before removing any cover.

### 4.2 RECOMMENDED TEST EQUIPMENT

The recommended test equipment required to test and maintain the Model 247 is listed in Table 4-1.

Table 4-1. Recommended Test Equipment

Item	Description	Specifications	Manufacturer	Model
A	Oscilloscope	10MHz	Phillips	3234
B	Digital Voltmeter	.001%	Keithley	192
C	Variable Auto Transformer		General Radio	3030-5118
D	Voltage Divider	1000 to 1	Julie Research	HV-10
E	Load Resistor	—	Clarostat	VP-50-k-50k-50M
F*	AC Viewing Circuit			
G	Power Line Ammeter	.1%	Valhalla Scientific	2000

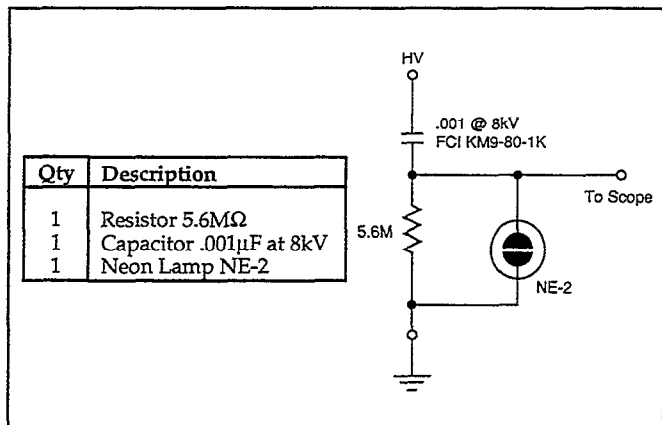

### 4.3 PREPARATION FOR MEASUREMENTS

Connect the HIGH VOLTAGE OUTPUT of the Model 247 to the high voltage terminal of the DC voltage divider (D) and to the capacitor input of the AC viewing circuit (F). The low voltage terminal of the DC divider should be connected to the digital voltmeter input, and the AC viewing circuit output connected to the oscilloscope input. Make sure that a good ground is connected to all instruments, viewing circuits and the Model 247. After the ground has been checked, adequate safety precautions have been taken, and the output voltage controls set at zero, input power can be applied. The AC input should be applied through the variable autotransformer, which should be initially set for 115 or 230 volts output, as appropriate.

### 4.4 CALIBRATION ADJUSTMENTS

#### WARNING

To prevent a shock hazard, remove the power cord and all test leads from the Model 247 before removing any cover.

Remove the top cover of the Model 247. Set the Volts switch to 0. Set the Volts dial to read 1000. Adjust the Reference Adjust Potentiometer (R172) of PCB 100 (see Figure 4-1) for an output voltage of 1000 volts.

Set the Volts dial to read 10 (with the Volts switch still at 0). Adjust the Offset Adjust Potentiometer (R171) for an output voltage of 10 volts. Set all front panel voltage controls for 3000 volt output and readjust the Reference Adjust Potentiometer (R172) if necessary.

Potentiometer R178 is an Overload Adjustment. To calibrate this adjustment set the Model 247 for full load and full voltage (3000V at 6mA) by using the load resistor (E) on the output. Adjust R178 until the voltage drops off and then back off of R178 approximately 1/8 of a turn.

Potentiometer R173 is a Frequency Adjustment. To calibrate this adjustment set the Model 247 for full load and full voltage (3000V at 6mA) by using the load resistor (E) on the output. Adjust R173 for minimum AC power line current.

Adjustment is not complete. The following performance tests are used to determine that the unit meets all of its specifications.

### 4.5 PERFORMANCE TESTS

Check to assure that the procedures in paragraph 4.3 have been followed.

#### NOTE

Performance tests may be performed without doing the calibration.

Turn the front panel output volts control fully clockwise until the reading on the digital voltmeter indicates maximum output from the Model 247.

Connect one end of the high voltage load resistor to ground and the other end to a shorting stick (1 ft. insulated stick to which the load resistor is attached). Then, with the shorting stick, connect the load resistor across the high voltage output and observe the change in output voltage. During this no load to full load test, the digital voltmeter reading should not change by more than 0.005%.

With the load connected as above, observe the AC ripple voltage on the oscilloscope. The ripple should be less than the specified peak-to-peak ripple under this condition of full load and maximum output voltage.

Vary the autotransformer to produce an AC line input change of +10% to the power supply, and again observe the change in digital voltmeter reading. This change should be less than 0.001%.

Additional line and load regulation and ripple measurements may be performed at other voltage levels using the same procedure outlined above. This should not usually be necessary. Satisfactory test data at maximum output voltage and the full range of voltage control generally indicate that satisfactory test data will be obtained at all voltage levels. However, full range testing is performed at the factory on each unit prior to shipment.

## 4.6 TROUBLESHOOTING PROCEDURE

A Model 247 High Voltage Power Supply consists of easily replaceable plug-in printed circuit boards, and a main chassis assembly which includes the high voltage circuitry. The basic troubleshooting procedure consists of determining which of these assemblies is defective. Removal of the top cover provides access to the printed circuit board and high voltage components. The printed circuit board is secured by four screws to the bottom of the chassis.

No further disassembly is required for troubleshooting purposes. Make sure all test instruments are grounded, either to the high voltage connector shield, or directly to the chassis, prior to the application of input power to the unit. The following procedures should then be followed.

Remove connector/cable from P303 on PCB300 (see Figure 4-1 for location). This leaves only the low voltage B+ and the unregulated +20 volt power supplies operable. Turn on the AC line power and measure the DC voltage obtained across R101. (See Figure 4-1 for location.) This

voltage should be approximately +41VDC. If this voltage differs by more than 15%, the power transformer, or PCB100 is probably defective.

If the B+ supply is operating properly, check for unregulated  $\pm 20$ VDC output accessible across C103(+) and C131(-) on PCB100. The + voltages should be of equal magnitude to within 5% and within the range of 16 to 24VDC. If the magnitude and tracking are not within the range specified, this circuitry is probably defective.

If all of the low voltage power supplies are operating properly, turn off input power, insert connector to P303, turn all voltage controls to zero, follow the PREPARATION FOR MEASUREMENTS procedure in paragraph 4.3, and turn the line power back on

If output voltage can be obtained, but the unit does not properly regulate or the front panel control does not operate properly, PCB 100 is probably defective.

If no output voltage is obtainable, test for AC drive to the base of transistor Q1 or Q2 located on the rear of the unit. If drive is present, the high voltage assembly or transistors are probably defective.

It is recommended that the unit be returned to the factory for the repair of the high voltage assembly. Specify model number and serial number in all correspondence with the factory.

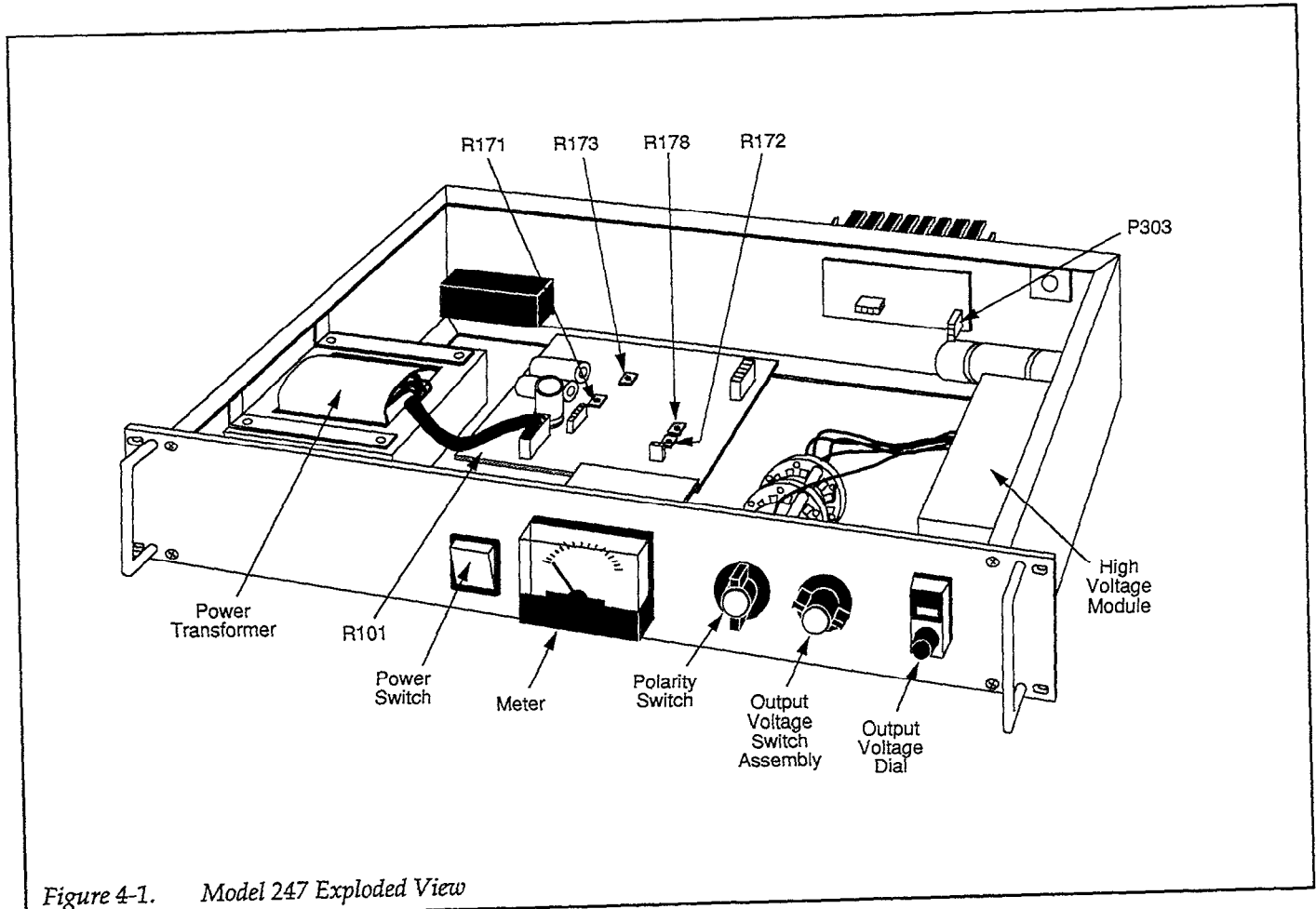

Figure 4-1. Model 247 Exploded View

# SECTION 5

## Replaceable Parts

---

---

### 5.1 INTRODUCTION

Operational spares to support the Model 247 are available from the factory. It is recommended that common electronic components (i.e. resistors, capacitors, transistors, etc.) be purchased from local electronics distributors. These parts are called out on the schematic diagrams located on the following pages.

### 5.2 ORDERING INFORMATION

To place an order or to obtain information concerning replacement parts, contact your Keithley representative or the factory. See inside front cover for addresses. When ordering, include the following information:

1. Instrument Model Number
2. Instrument Serial Number
3. Parts Description
4. Circuit Description (if applicable)
5. Part Number

### 5.3 FACTORY SERVICE

If the instrument is to be returned to the factory for service, please complete the Service Form which follows this section, and return it with the instrument.

Table 5-1. Model 247 Replacement Parts

Description	Part Number
Printed Circuit Card (PCB 100)	109641
Printed Circuit Card (PCB 300)	208329
High Voltage module	308028
Power transformer	40152
Bridge rectifier	EDI #PK 10
HV connector	UG 931/U
HV Mating connector	UG 932/U
Meter	309206-1
Power switch	212JG1B60X03
Output Voltage switch assembly	301317
Polarity switch	204737
Rubber bumper	H.H. Smith #2192



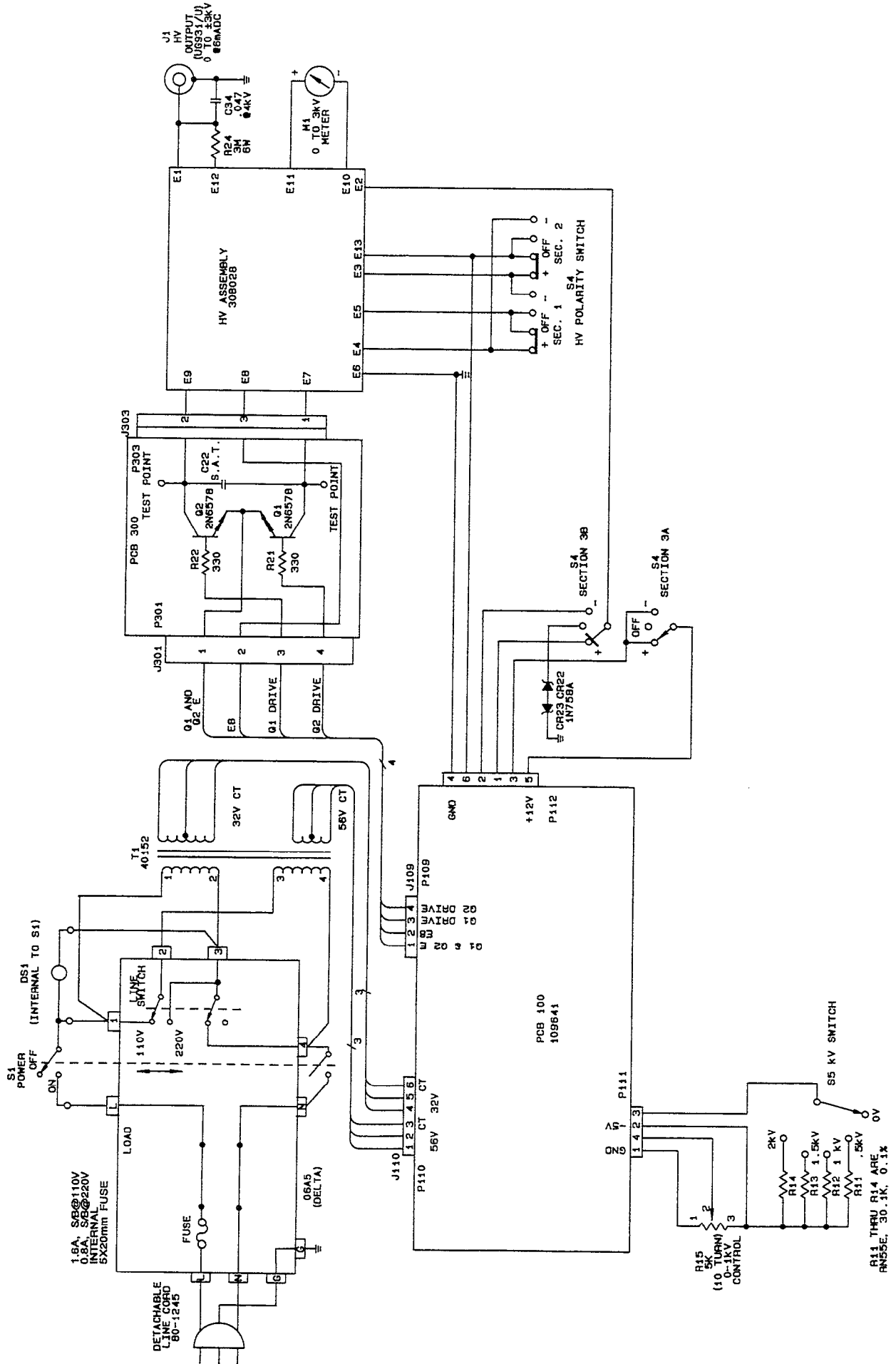





# Service Form

Model No. \_\_\_\_\_ Serial No. \_\_\_\_\_ Date \_\_\_\_\_

Name and Telephone No. \_\_\_\_\_

Company \_\_\_\_\_

List all control settings, describe problem and check boxes that apply to problem. \_\_\_\_\_

\_\_\_\_\_

- |  |  |  |
|--|--|--|
| <input type="checkbox"/> Intermittent            | <input type="checkbox"/> Analog output follows display   | <input type="checkbox"/> Particular range or function bad; specify |
| <input type="checkbox"/> IEEE failure            | <input type="checkbox"/> Obvious problem on power-up     | <input type="checkbox"/> Batteries and fuses are OK                |
| <input type="checkbox"/> Front panel operational | <input type="checkbox"/> All ranges or functions are bad | <input type="checkbox"/> Checked all cables                        |

Display or output (check one)

- |                                   |  |
|-----------------------------------|--|
| <input type="checkbox"/> Drifts   | <input type="checkbox"/> Unable to zero              |
| <input type="checkbox"/> Unstable | <input type="checkbox"/> Will not read applied input |
| <input type="checkbox"/> Overload |  |

Calibration only       Certificate of calibration required

Data required

(attach any additional sheets as necessary)

Show a block diagram of your measurement system including all instruments connected (whether power is turned on or not). Also, describe signal source.

Where is the measurement being performed? (factory, controlled laboratory, out-of-doors, etc.)

\_\_\_\_\_

What power line voltage is used? \_\_\_\_\_ Ambient temperature? \_\_\_\_\_ °F

Relative humidity? \_\_\_\_\_ Other? \_\_\_\_\_

Any additional information. (If special modifications have been made by the user, please describe.)

\_\_\_\_\_

Be sure to include your name and phone number on this service form.

**KEITHLEY**

**Test Instrumentation Group**  
**Keithley Instruments, Inc.**  
28775 Aurora Road  
Cleveland, Ohio 44139

Printed in the U.S.A.