

# Model 238 High Current Source Measure Unit

Service Manual

Contains Servicing Information

**KEITHLEY**

# WARRANTY

Keithley Instruments, Inc. warrants this product to be free from defects in material and workmanship for a period of 1 year from date of shipment.

Keithley Instruments, Inc. warrants the following items for 90 days from the date of shipment: probes, cables, rechargeable batteries, diskettes, and documentation.

During the warranty period, we will, at our option, either repair or replace any product that proves to be defective.

To exercise this warranty, write or call your local Keithley representative, or contact Keithley headquarters in Cleveland, Ohio. You will be given prompt assistance and return instructions. Send the product, transportation prepaid, to the indicated service facility. Repairs will be made and the product returned, transportation prepaid. Repaired or replaced products are warranted for the balance of the original warranty period, or at least 90 days.

## LIMITATION OF WARRANTY

This warranty does not apply to defects resulting from product modification without Keithley's express written consent, or misuse of any product or part. This warranty also does not apply to fuses, software, non-rechargeable batteries, damage from battery leakage, or problems arising from normal wear or failure to follow instructions.

THIS WARRANTY IS IN LIEU OF ALL OTHER WARRANTIES, EXPRESSED OR IMPLIED, INCLUDING ANY IMPLIED WARRANTY OF MERCHANTABILITY OR FITNESS FOR A PARTICULAR USE. THE REMEDIES PROVIDED HEREIN ARE BUYER'S SOLE AND EXCLUSIVE REMEDIES.

NEITHER KEITHLEY INSTRUMENTS, INC. NOR ANY OF ITS EMPLOYEES SHALL BE LIABLE FOR ANY DIRECT, INDIRECT, SPECIAL, INCIDENTAL OR CONSEQUENTIAL DAMAGES ARISING OUT OF THE USE OF ITS INSTRUMENTS AND SOFTWARE EVEN IF KEITHLEY INSTRUMENTS, INC., HAS BEEN ADVISED IN ADVANCE OF THE POSSIBILITY OF SUCH DAMAGES. SUCH EXCLUDED DAMAGES SHALL INCLUDE, BUT ARE NOT LIMITED TO: COSTS OF REMOVAL AND INSTALLATION, LOSSES SUSTAINED AS THE RESULT OF INJURY TO ANY PERSON, OR DAMAGE TO PROPERTY.

**KEITHLEY**

Keithley Instruments, Inc. • 28775 Aurora Road • Cleveland, OH 44139 • 440-248-0400 • Fax: 440-248-6168 • <http://www.keithley.com>

BELGIUM:	Keithley Instruments B.V.	Bergensesteenweg 709 • B-1600 Sint-Pieters-Leeuw • 02/363 00 40 • Fax: 02/363 00 64
CHINA:	Keithley Instruments China	Yuan Chen Xin Building, Room 705 • 12 Yumin Road, Deswai, Madian • Beijing 100029 • 8610-62022886 • Fax: 8610-62022892
FRANCE:	Keithley Instruments Sarl	B.P. 60 • 3, allée des Garays • 91122 Palaiseau Cédex • 01 64 53 20 20 • Fax: 01 60 11 77 26
GERMANY:	Keithley Instruments GmbH	Landsberger Strasse 65 • D-82110 Germering • 089/84 93 07-40 • Fax: 089/84 93 07-34
GREAT BRITAIN:	Keithley Instruments Ltd	The Minster • 58 Portman Road • Reading, Berkshire RG30 1EA • 0118-9 57 56 66 • Fax: 0118-9 59 64 69
INDIA:	Keithley Instruments GmbH	Flat 2B, WILOCRISSA • 14, Rest House Crescent • Bangalore 560 001 • 91-80-509-1320/21 • Fax: 91-80-509-1322
ITALY:	Keithley Instruments s.r.l.	Viale S. Gimignano, 38 • 20146 Milano • 02/48 30 30 08 • Fax: 02/48 30 22 74
NETHERLANDS:	Keithley Instruments B.V.	Postbus 559 • 4200 AN Gorinchem • 0183-635333 • Fax: 0183-630821
SWITZERLAND:	Keithley Instruments SA	Kriesbachstrasse 4 • 8600 Dübendorf • 01-821 94 44 • Fax: 01-820 30 81
TAIWAN:	Keithley Instruments Taiwan	1 Fl. 85 Po Ai Street • Hsinchu, Taiwan, R.O.C. • 886-3572-9077 • Fax: 886-3572-903

10/99

# Model 238 High Current Source Measure Unit Service Manual

©1990, Keithley Instruments, Inc.  
Test Instrument Group  
All rights reserved.  
Cleveland, Ohio, U.S.A.  
Third Printing, May 2000  
Document Number: 238-902-01 Rev. C

# Manual Print History

The print history shown below lists the printing dates of all Revisions and Addenda created for this manual. The Revision Level letter increases alphabetically as the manual undergoes subsequent updates. Addenda, which are released between Revisions, contain important change information that the user should incorporate immediately into the manual. Addenda are numbered sequentially. When a new Revision is created, all Addenda associated with the previous Revision of the manual are incorporated into the new Revision of the manual. Each new Revision includes a revised copy of this print history page.

Revision B (Document Number 238-902-01) ..... August 1992  
Revision C (Document Number 238-902-01) ..... May 2000

All Keithley product names are trademarks or registered trademarks of Keithley Instruments, Inc.  
Other brand and product names are trademarks or registered trademarks of their respective holders.

# Safety Precautions

---

The following safety precautions should be observed before using this product and any associated instrumentation. Although some instruments and accessories would normally be used with non-hazardous voltages, there are situations where hazardous conditions may be present.

This product is intended for use by qualified personnel who recognize shock hazards and are familiar with the safety precautions required to avoid possible injury. Read the operating information carefully before using the product.

The types of product users are:

**Responsible body** is the individual or group responsible for the use and maintenance of equipment, for ensuring that the equipment is operated within its specifications and operating limits, and for ensuring that operators are adequately trained.

**Operators** use the product for its intended function. They must be trained in electrical safety procedures and proper use of the instrument. They must be protected from electric shock and contact with hazardous live circuits.

**Maintenance personnel** perform routine procedures on the product to keep it operating, for example, setting the line voltage or replacing consumable materials. Maintenance procedures are described in the manual. The procedures explicitly state if the operator may perform them. Otherwise, they should be performed only by service personnel.

**Service personnel** are trained to work on live circuits, and perform safe installations and repairs of products. Only properly trained service personnel may perform installation and service procedures.

Exercise extreme caution when a shock hazard is present. Lethal voltage may be present on cable connector jacks or test fixtures. The American National Standards Institute (ANSI) states that a shock hazard exists when voltage levels greater than 30V RMS, 42.4V peak, or 60VDC are present. **A good safety practice is to expect that hazardous voltage is present in any unknown circuit before measuring.**

Users of this product must be protected from electric shock at all times. The responsible body must ensure that users are prevented access and/or insulated from every connection point. In some cases, connections must be exposed to potential human contact. Product users in these circumstances must be trained to protect themselves from the risk of electric shock. If the circuit is capable of operating at or above 1000 volts, **no conductive part of the circuit may be exposed.**

As described in the International Electrotechnical Commission (IEC) Standard IEC 664, digital multimeter measuring circuits (e.g., Keithley Models 175A, 199, 2000, 2001, 2002, and 2010) are Installation Category II. All other instruments' signal terminals are Installation Category I and must not be connected to mains.

Do not connect switching cards directly to unlimited power circuits. They are intended to be used with impedance limited sources. **NEVER** connect switching cards directly to AC mains. When connecting sources to switching cards, install protective devices to limit fault current and voltage to the card.

Before operating an instrument, make sure the line cord is connected to a properly grounded power receptacle. Inspect the connecting cables, test leads, and jumpers for possible wear, cracks, or breaks before each use.

For maximum safety, do not touch the product, test cables, or any other instruments while power is applied to the circuit under test. **ALWAYS** remove power from the entire test system and discharge any capacitors before: connecting or disconnecting cables or jumpers, installing or removing switching cards, or making internal changes, such as installing or removing jumpers.

Do not touch any object that could provide a current path to the common side of the circuit under test or power line (earth) ground. Always make measurements with dry hands while standing on a dry, insulated surface capable of withstanding the voltage being measured.

The instrument and accessories must be used in accordance with its specifications and operating instructions or the safety of the equipment may be impaired.

Do not exceed the maximum signal levels of the instruments and accessories, as defined in the specifications and operating information, and as shown on the instrument or test fixture panels, or switching card.

When fuses are used in a product, replace with same type and rating for continued protection against fire hazard.

Chassis connections must only be used as shield connections for measuring circuits, NOT as safety earth ground connections.

If you are using a test fixture, keep the lid closed while power is applied to the device under test. Safe operation requires the use of a lid interlock.

If a  screw is present, connect it to safety earth ground using the wire recommended in the user documentation.

The  symbol on an instrument indicates that the user should refer to the operating instructions located in the manual.

The  symbol on an instrument shows that it can source or measure 1000 volts or more, including the combined effect of normal and common mode voltages. Use standard safety precautions to avoid personal contact with these voltages.

The **WARNING** heading in a manual explains dangers that might result in personal injury or death. Always read the associated information very carefully before performing the indicated procedure.

The **CAUTION** heading in a manual explains hazards that could damage the instrument. Such damage may invalidate the warranty.

Instrumentation and accessories shall not be connected to humans.

Before performing any maintenance, disconnect the line cord and all test cables.

To maintain protection from electric shock and fire, replacement components in mains circuits, including the power transformer, test leads, and input jacks, must be purchased from Keithley Instruments. Standard fuses, with applicable national safety approvals, may be used if the rating and type are the same. Other components that are not safety related may be purchased from other suppliers as long as they are equivalent to the original component. (Note that selected parts should be purchased only through Keithley Instruments to maintain accuracy and functionality of the product.) If you are unsure about the applicability of a replacement component, call a Keithley Instruments office for information.

To clean an instrument, use a damp cloth or mild, water based cleaner. Clean the exterior of the instrument only. Do not apply cleaner directly to the instrument or allow liquids to enter or spill on the instrument. Products that consist of a circuit board with no case or chassis (e.g., data acquisition board for installation into a computer) should never require cleaning if handled according to instructions. If the board becomes contaminated and operation is affected, the board should be returned to the factory for proper cleaning/servicing.

# Model 238 Source Measure Unit Specifications

**SOURCE-MEASURE UNIT:** Sources voltage while measuring current, or sources current while measuring voltage.

**FUNCTION:** Can be used as DC source or meter, sweep source, or full source-measure unit.

**SOURCE-DELAY-MEASURE CYCLE:**

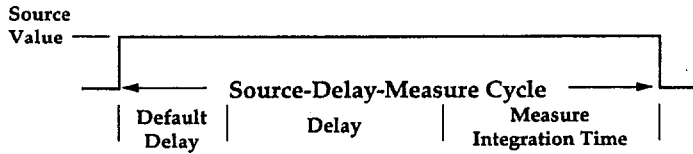

**Default Delay:** Fixed delay for instrument settling.

**User Delay:** Additional delay for device under test or system capacitance.

**MEASURE:**

**Integration Time:**

Fast	416 μsec.	4-digit resolution
Medium	4 msec.	5-digit resolution
Line Cycle	16.67 msec. (60 Hz) 20.00 msec. (50 Hz)	5-digit resolution

**Elapsed Time:** Measures and stores time from sweep trigger to measurement complete for each step of sweep.

**RANGING:**

**Source:** Auto-ranging through keypad entry; fixed range selection using rotary dial and SELECT keys (DC function). Fully programmable in SWEEP function.

**Measure:** Auto or fixed range. Fixed range selection made by choice of COMPLIANCE value.

**FILTER:** Takes n measurements, calculates and outputs average (n = 2, 4, 8, 16, or 32, selectable).

**SUPPRESS:** Subtracts displayed measurement from subsequent readings.

**MENU:** DC Measurement Delay, Default Delay On/Off, Local/Remote Sense, 50/60Hz, IEEE Address, Self Tests.

**DATA ENTRY:** Numeric keypad or detented rotary dial.

**TRIGGER:**

**Input and Output:** Set for any phase of SOURCE-DELAY-MEASURE sequence or trigger output at end of sweep.

**Origin:** Internal, External (including front panel MANUAL TRIGGER button), IEEE-488 bus (TALK, GET, "X").

**MEMORY:** Stores one full sweep (up to 1000 points) of source, delay, and measure values, elapsed times, and sweep parameters. Lithium battery backup.

**INTERLOCK:** Use with test fixture or external switch. Normally closed; open puts instrument in standby.

## VOLTAGE

RANGE (Max. Value)	STEP SIZE	ACCURACY (1 Year, 18°-28°C)	MEASURE V		ACCURACY <sup>1</sup> (1 Year, 18°-28°C)
			RESOLUTION 4-Digit	5-Digit	
±1.5000V	100 μV	±(0.033% + 800μV + [I <sub>o</sub> /I <sub>FS</sub> ] × 600μV) <sup>2</sup>	100 μV	10 μV	±(0.028% + 450μV + [I <sub>o</sub> /I <sub>FS</sub> ] × 600μV) <sup>2</sup>
±15.000V	1mV	±(0.033% + 2.7mV)	1mV	100 μV	±(0.025% + 1.3mV)
±110.00V	10mV	±(0.033% + 24mV)	10mV	1mV	±(0.025% + 10mV)

I<sub>o</sub> = Output current

I<sub>FS</sub> = Full scale on selected current range

<sup>1</sup>Specifications apply for 5-digit resolution. For 4-digit resolution add 100ppm of range. Assumes remote sense for I > 100μA.

<sup>2</sup>On the 1A range use [I<sub>o</sub>/I<sub>FS</sub>] × 250μV.

**COMPLIANCE:** Bipolar current limit set with single value.

**Maximum:** ±1A (±100mA on the 110V range).

**Minimum:** ±1% of selected voltage range.

**Accuracy, Step Size:** Same as current source.

**NOISE (p-p typical):**

Range	0.1-10Hz
110 V	< 3ppm of range
15 V	< 3ppm of range
1.5 V	< 10ppm of range

**WIDEBAND NOISE:** 0.1 to 20MHz, 8mV p-p typical.

**OVERSHOOT:** <0.01% (110V step, 10mA range).

**SETTLING TIME:** <500μsec. to 0.01% (110V step, 10mA range).

**NMRR:** >60dB at 50 or 60Hz (LINE CYCLE integration time selected).

**CMRR:** >120dB at DC, 50 or 60Hz (LINE CYCLE integration time selected).

**INPUT IMPEDANCE (as a voltmeter):** >10<sup>14</sup>Ω paralleled by <20pF.

## CURRENT

RANGE (Max. Value)	STEP SIZE	ACCURACY (1 Year, 18°-28°C)	MEASURE I		ACCURACY <sup>1,2</sup> (1 Year, 18°-28°C)
			RESOLUTION 4-Digit	5-Digit	
±1.0000 nA	100 fA	±(0.3 % + 450 fA)	100 fA	10 fA	±(0.3 % + 100 fA) <sup>2</sup>
±10.000 nA	1 pA	±(0.3 % + 2 pA)	1 pA	100 fA	±(0.3 % + 1 pA)
±100.00 nA	10 pA	±(0.21% + 20 pA)	10 pA	1 pA	±(0.21 % + 6 pA)
±1.0000 μA	100 pA	±(0.05% + 200 pA)	100 pA	10 pA	±(0.04 % + 60 pA)
±10.000 μA	1 nA	±(0.05% + 2 nA)	1 nA	100 pA	±(0.035% + 700 pA)
±100.00 μA	10 nA	±(0.05% + 20 nA)	10 nA	1 nA	±(0.035% + 6 nA)
±1.0000 mA	100 nA	±(0.05% + 200 nA)	100 nA	10 nA	±(0.035% + 60 nA)
±10.000 mA	1 μA	±(0.05% + 2 μA)	1 μA	100 nA	±(0.038% + 600 nA)
±100.00 mA	10 μA	±(0.1 % + 20 μA)	10 μA	1 μA	±(0.1 % + 6 μA)
±1.0000 A	100 μA	±(0.12% + 700 μA)	100 μA	10 μA	±(0.12 % + 300 μA)

<sup>1</sup>Specifications apply for 5-digit resolution. For 4-digit resolution, all offset terms are 200ppm of range.

<sup>2</sup>Offset specification applies for 23°C ± 1°C with suppression. Temperature coefficient 50fA/°C.

**COMPLIANCE:** Bipolar voltage limit set with single value.

**Maximum:** ±110V (±15V on the 1A range).

**Minimum:** ±1% of selected current range.

**Accuracy, Step Size:** Same as voltage source.

**NOISE (p-p of range):** 0.1-10Hz: <3ppm (<20ppm on 1nA, 10nA and 1A ranges).

**OVERSHOOT:** <0.01% typical (10mA step, R<sub>L</sub> = 10kΩ).

**SETTLING TIME:** <500μsec. to 0.01% (10mA step, R<sub>L</sub> = 10kΩ).

**OUTPUT R, C:** >10<sup>14</sup>Ω paralleled by <20pF (on 1nA range).

Specifications subject to change without notice.

## IEEE-488 BUS IMPLEMENTATION

**MULTILINE COMMANDS:** DCL, LLO, SDC, GET, GTL, UNT, UNL, SPE, SPD.

**UNILINE COMMANDS:** IFC, REN, EOI, SRQ, ATN.

**INTERFACE FUNCTIONS:** SH1, AH1, T6, TE0, L4, LE0, SR1, RL1, PP0, DC1, DT1, C0, E1.

All front panel functions and setups are available over the IEEE-488 bus, in addition to Status, Service Request, Output Format, EOI, Trigger, and Terminator.

IEEE-488 address is set from front panel menu.

---

## EXECUTION SPEED

**MINIMUM SOURCE-DELAY-MEASURE CYCLE TIME:** 1msec.

**RESPONSE TO IEEE-488 COMMAND (as a source):** 25msec.

**MEASUREMENT RATE:** 1msec. per point into internal buffer.

**CONTINUOUS MEASUREMENT SPEED (source DC value over IEEE-488 bus):** 110 readings per second.

**TRIGGER LATENCY TIME:** <2msec.

---

## GENERAL

**LOAD CAPACITANCE:** Stable into 20,000pF typical.

**REMOTE SENSE:** Corrects for up to 2V drop in each output lead. Maximum 1k $\Omega$  per sense lead for rated accuracy. Residual output resistance (as a voltage source) is 0.5 $\Omega$ .

**GUARD:** Output Resistance:  $\leq 12k\Omega$ .

Maximum Output Current:  $\pm 2mA$ .

Open Circuit Offset Relative to Output HI:  $\pm 2mV$  max.

**ISOLATION (Output LO to chassis):** Typically  $>10^{10}\Omega$  in parallel with 650pF.

**MAXIMUM COMMON MODE VOLTAGE:** 200V peak.

**CONNECTORS:** Outputs: 3-lug triax.

Trigger Input/Output: BNC.

Interlock: 3-pin miniature DIN.

**TEMPERATURE COEFFICIENT (0 $^{\circ}$ -18 $^{\circ}$ C & 28 $^{\circ}$ -50 $^{\circ}$ C):**  
 $\pm(0.1 \times \text{applicable accuracy specification})/^{\circ}\text{C}$ .

**ENVIRONMENT:**

**Operating:** 0 $^{\circ}$ -50 $^{\circ}$ C, 70% relative humidity up to 35 $^{\circ}$ C. Linearly derate 3% RH/ $^{\circ}$ C, 35 $^{\circ}$ -50 $^{\circ}$ C.

**Storage:** -25 $^{\circ}$  to 65 $^{\circ}$ C.

**WARM-UP:** One hour to rated accuracy.

**COOLING:** Internal fan forced air cooling.

**POWER:** 105-125 or 210-250V AC (external switch selectable), 90-110V and 180-220V version available. 120VA max.

**DIMENSIONS, WEIGHT:** 89mm high  $\times$  435mm wide  $\times$  448mm deep (3 $\frac{1}{2}$  in.  $\times$  17 $\frac{1}{4}$  in.  $\times$  17 $\frac{3}{8}$  in.). Net weight 9kg (19.75 lbs.).

**ACCESSORIES SUPPLIED:**

Model 7078-TRX-10: Triax to Triax Cable, 3m (10 ft.) (2 supplied)

Model 236-ILC-3: Interlock Cable

**ACCESSORIES AVAILABLE:**

Model 8000-10: Equipment Rack for 3 SMUs (10 in.)

Model 8000-14: Equipment Rack for 4 SMUs (14 in.)



# Table of Contents

## SECTION 1 — Performance Verification

1.1	INTRODUCTION . . . . .	1-1
1.2	ENVIRONMENTAL CONDITIONS . . . . .	1-1
1.3	INITIAL CONDITIONS . . . . .	1-1
1.4	REQUIRED TEST EQUIPMENT . . . . .	1-1
1.5	VERIFICATION PROCEDURES . . . . .	1-1
1.5.1	Equipment Characterization . . . . .	1-3
1.5.2	Common Mode Verification . . . . .	1-6
1.5.3	Voltage Source Verification . . . . .	1-7
1.5.4	Voltage Measure Verification . . . . .	1-8
1.5.5	Remote Sense Verification . . . . .	1-10
1.5.6	Low Current (1nA to 10mA) Measure Ranges Verification . . . . .	1-11
1.5.7	Low Current (1nA to 10mA) Source Ranges Verification . . . . .	1-13
1.5.8	100mA and 1A Measure Ranges Verification . . . . .	1-16
1.5.9	100mA and 1A Source Ranges Verification . . . . .	1-16

## SECTION 2 — Calibration

2.1	INTRODUCTION . . . . .	2-1
2.2	RECOMMENDED CALIBRATION EQUIPMENT . . . . .	2-1
2.3	ENVIRONMENTAL CONDITIONS . . . . .	2-1
2.4	WARM-UP PERIOD . . . . .	2-1
2.5	CAL LOCK . . . . .	2-2
2.6	CALIBRATION PROCEDURES . . . . .	2-2
2.6.1	Equipment Characterization . . . . .	2-2
2.6.2	Voltage Calibration . . . . .	2-5
2.6.3	100mA and 1A Ranges Calibration . . . . .	2-8
2.6.4	Low Current Ranges Calibration (1nA – 10mA) . . . . .	2-11
2.7	CALIBRATION ERRORS . . . . .	2-13
2.8	CALIBRATION PROGRAM . . . . .	2-14

## SECTION 3 — Maintenance

3.1	INTRODUCTION . . . . .	3-1
3.2	LINE FUSE REPLACEMENT . . . . .	3-1
3.3	FAN FILTER CLEANING . . . . .	3-1
3.4	BATTERY REPLACEMENT . . . . .	3-2
3.5	HANDLING AND CLEANING PRECAUTIONS . . . . .	3-2
3.6	DISASSEMBLY INSTRUCTIONS . . . . .	3-4
3.7	SPECIAL HANDLING OF STATIC SENSITIVE DEVICES . . . . .	3-8
3.8	TROUBLESHOOTING . . . . .	3-8
3.8.1	Recommended Test Equipment . . . . .	3-8

3.8.2	Diagnostics .....	3-8
3.8.3	Power Supply Checks .....	3-10
3.8.4	Analog Control Lines .....	3-10
3.8.5	Analog Switching .....	3-11
3.8.6	Digital and Display Checks .....	3-12

## **SECTION 4 — Principles of Operation**

4.1	INTRODUCTION .....	4-1
4.2	ANALOG CIRCUITRY .....	4-2
4.2.1	V/I Control and Readback .....	4-2
4.2.2	Output Module .....	4-4
4.2.3	V/I Feedback .....	4-5
4.3	A/D CONVERTER .....	4-8
4.4	DIGITAL CIRCUITRY .....	4-8
4.4.1	I/O Controller .....	4-8
4.4.2	Source/Measure Controller .....	4-9
4.4.3	Communications .....	4-9
4.4.4	Display Circuitry .....	4-9
4.5	POWER SUPPLY .....	4-10

## **SECTION 5 — Replaceable Parts**

5.1	INTRODUCTION .....	5-1
5.2	PARTS LISTS .....	5-1
5.3	ORDERING INFORMATION .....	5-1
5.4	FACTORY SERVICE .....	5-1
5.5	SCHEMATIC DIAGRAMS AND COMPONENT LOCATION DRAWINGS .....	5-1

# List of Illustrations

## SECTION 1 — Performance Verification

Figure 1-1	Setup for Equipment Characterization . . . . .	1-5
Figure 1-2	Setup for Common Mode Verification . . . . .	1-6
Figure 1-3	Setup for Voltage Source Ranges Verification . . . . .	1-7
Figure 1-4	Setup for Voltage Measure Ranges Verification . . . . .	1-9
Figure 1-5	Setup for Remote Sense Verification . . . . .	1-10
Figure 1-6	Setup for Low Current Measure Ranges Verification (1nA to 10mA) . . . . .	1-12
Figure 1-7	Setup for Low Current Source Ranges Verification (1nA to 10mA) . . . . .	1-15
Figure 1-8	Setup for 100mA and 1A Measure Ranges Verification . . . . .	1-17
Figure 1-9	Setup for 100mA and 1A Source Ranges Verification . . . . .	1-18

## SECTION 2 — Calibration

Figure 2-1	Calibration Switch (Cal Lock) . . . . .	2-2
Figure 2-2	Setup for Equipment Characterization . . . . .	2-3
Figure 2-3	Setup for Volts Calibration . . . . .	2-6
Figure 2-4	Setup for 100mA and 1A Ranges Calibration . . . . .	2-9
Figure 2-5	Current Ranges Calibration (1nA to 10mA) . . . . .	2-11
Figure 2-6	U1 Error Status Word . . . . .	2-14
Figure 2-7	U7 Calibration Status Word . . . . .	2-14

## SECTION 3 — Maintenance

Figure 3-1	Line Voltage Switch and Line Fuse . . . . .	3-1
Figure 3-2.	Digital Board . . . . .	3-3
Figure 3-3.	Output Board . . . . .	3-5
Figure 3-4.	Analog Board (Shields Removed) . . . . .	3-6
Figure 3-5	Model 238 Exploded View . . . . .	3-7

## SECTION 4 — Principles of Operation

Figure 4-1.	Overall Block Diagram . . . . .	4-1
Figure 4-2.	Simplified Schematic of V/I Control and Readback . . . . .	4-2
Figure 4-3.	Output Module (Simplified Schematic Diagram) . . . . .	4-5
Figure 4-4.	V/I Feedback (Simplified Schematic) . . . . .	4-6
Figure 4-5.	Damping Relay Contact Bounce . . . . .	4-7

# List of Tables

## SECTION 1 — Performance Verification

Table 1-1	Required Test Equipment .....	1-2
Table 1-2	Specifications for Alternate Equipment .....	1-3
Table 1-3	Model 263 I-Source Characterization .....	1-4
Table 1-4	Voltage Source Verification .....	1-8
Table 1-5	Voltage Measure Verification .....	1-9
Table 1-6	Allowable Reading Calculations for Low Current Measure Verification ( $\mu\text{A}$ to $10\text{mA}$ ) .....	1-11
Table 1-7	Low Current Measure Verification ( $\text{InA}$ to $10\text{mA}$ ) .....	1-12
Table 1-8	Allowable Reading Calculations for Low Current Source Verification ( $\text{InA}$ to $10\text{mA}$ ) .....	1-13
Table 1-9	Low Current Source Verification ( $\text{InA}$ to $10\text{mA}$ ) .....	1-14

## SECTION 2 — Calibration

Table 2-1	Required Test Equipment .....	2-1
Table 2-2	Specifications for Alternate Equipment .....	2-2
Table 2-3	Model 263 I-Source Characterization .....	2-5
Table 2-4	Calibration Error Messages .....	2-13

## SECTION 3 — Maintenance

Table 3-1	Line Fuse Selection .....	3-1
Table 3-2	Recommended Troubleshooting Equipment .....	3-8
Table 3-3	Power Supply Checks .....	3-10
Table 3-4	Analog Switching; Current Ranging .....	3-11
Table 3-5	Analog Switching; Current Ranging .....	3-11
Table 3-6	Analog Switching; Feedback .....	3-12
Table 3-7	Analog Switching; Sensing .....	3-12
Table 3-8	Analog Switching; A/D Multiplexing .....	3-12
Table 3-9	Digital Circuitry Checks .....	3-13
Table 3-10	Display Circuitry Checks .....	3-14

## SECTION 4 — Principles of Operation

Table 4-1	Volts Range Relays .....	4-8
-----------	--------------------------	-----



# SECTION 1

## Performance Verification

---

### 1.1 INTRODUCTION

The procedures outlined in this section may be used to verify that the instrument is operating within the limits stated in the specifications at the front of this manual. Performance verification may be performed when the instrument is first received to ensure that no damage or misadjustment has occurred during shipment. Verification may also be performed whenever there is question of instrument accuracy, or following calibration, if desired.

#### NOTE

If the instrument is still under warranty (less than 1 year from the date of shipment), and its performance falls outside the specified range, contact your Keithley representative or the factory to determine the correct course of action.

Before attempting any of the following procedures, make sure you are familiar with the controls and operation of the Model 238. Refer to the Model 238 Operator's Manual for complete information.

#### WARNING

The procedures in this section are for use only by qualified service personnel. Do not perform these procedures unless qualified to do so. Many of these steps in this section may expose you to potentially lethal voltages that could result in personal injury or death if normal safety precautions are not observed.

### 1.2 ENVIRONMENTAL CONDITIONS

All measurements should be made at 18-28°C (65-82°F) and at less than 70% humidity.

### 1.3 INITIAL CONDITIONS

#### WARNING

The Source Measure Unit is equipped with a 3-wire power cord that contains a separate ground wire and is designed to be used with grounded outlets. When proper connections are made, instrument chassis is connected to power line ground. Failure to use a grounded outlet may result in injury or death due to electric shock.

The Model 238 must be turned on and allowed to warm up for at least one hour before beginning the verification procedures. If the instrument has been subject to extremes of temperature (outside the range specified in paragraph 1.2), additional time should be allowed for internal temperatures to reach normal operating temperature. Typically, it takes one additional hour to stabilize a unit that is 10°C (18°F) outside the specified temperature range.

### 1.4 REQUIRED TEST EQUIPMENT

Table 1-1 lists all the test equipment required for verification. The procedures for performance verification are based on using this exact equipment.

Alternate equipment may be used as long as the substitute equipment has specifications at least as good as those listed in Table 1-2. Note that equipment characterization (paragraph 1.5.1) is not required if using equipment that meets the specifications in Table 1-2.

### 1.5 VERIFICATION PROCEDURES

The following paragraphs contain the detailed procedures for verifying the one year accuracy specifications of the Model 238 using the equipment listed in Table 1-1.

#### NOTE

The allowable reading limits in these procedures only reflect the specifications of the Model 238. They do not include error contributed by test equipment.





These procedures are intended for use only by qualified personnel using accurate and reliable test equipment. If the instrument is out of specifications and not under warranty, refer to the calibration section of this manual.

**WARNING**

Lethal voltages (up to 100V) will be connected to the Model 8006 test fixture. To avoid a possible shock hazard, the safety in-

terlock circuit must be connected to the Model 238.

Connect the test fixture screw to safety earth ground using #18 AWG wire minimum before use. Turn off all power before connecting or disconnecting wires or cables.

Also, keep in mind that GUARD is always enabled. Thus, a lethal voltage on OUTPUT HI is also present on the two GUARD terminals of the Model 238.

**Table 1-1 Required Test Equipment**

Manufacturer	Model	Description	Specifications
Keithley	263	5-1/2 digit Calibrator/ Source	2nA, 20nA ranges; $\pm(0.0625\% + 10 \text{ counts})$ 200nA range; $\pm(0.035\% + 10 \text{ counts})$
Keithley	193A	5-1/2 digit DMM	200mV, 2V ranges; $\pm(0.005\% + 2 \text{ counts})$ 20V-1000V ranges; $\pm(0.007\% + 1 \text{ count})$ 200 $\Omega$ -200k $\Omega$ ranges; $\pm(0.007\% + 2 \text{ counts})$ 200 $\mu$ A-2mA ranges; $\pm(0.09\% + 10 \text{ counts})$
Keithley	617	4-1/2 digit Electrometer	2pA range; $\pm(1.6\% + 66 \text{ counts})$ 20pA range; $\pm(1.6\% + 7 \text{ counts})$ 200pA range; $\pm(1.6\% + 1 \text{ count})$ 2nA range; $\pm(0.25\% + 5 \text{ counts})$ 20nA range; $\pm(0.25\% + 1 \text{ count})$ 200nA range; $\pm(0.25\% + 1 \text{ count})$ 2 $\mu$ A range; $\pm(0.15\% + 4 \text{ counts})$ 20 $\mu$ A range; $\pm(0.15\% + 1 \text{ count})$
Keithley	8006	Test Fixture	—
Keithley	236-ILC-3	Interlock Cable	—
Fluke	343A	DC Voltage Calibrator	10V-100V ranges; $\pm 0.002\%$
Valhalla	2500E	Current Calibrator	100mA-1A ranges; $\pm 0.025\%$
Keithley	R-249-100 R-263-1k R-263-100K	100 $\Omega$ Resistor 1k $\Omega$ Resistor 100k $\Omega$ Resistor	$\pm 0.1\%$ , $\pm 20 \text{ ppm}/^\circ\text{C}$ $\pm 0.1\%$ , $\pm 10 \text{ ppm}/^\circ\text{C}$ $\pm 0.1\%$ , $\pm 10 \text{ ppm}/^\circ\text{C}$
Keithley	7078-TRX	3-slot triax cable (3 required)	—
Keithley	6172	2-slot male to 3-lug female triax adapter (2 required)	—
Pomona	B-24	Banana plug cable (6 required)	—



**Table 1-2 Specifications for Alternate Equipment**

Instrument Type	Required Specifications
DMM	Same as Keithley 193A (see Table 1-1)
Source DC Current	0.9nA, 9nA, 90nA, Same as Keithley 263 (see Table 1-1) 0.9μA; ±180ppm 9μA, 90μA, 900μA, 9mA; ±170ppm 90mA; ±230ppm 0.9A; ±625ppm
Measure DC Current	250ppm rdg ±500nA

### 1.5.1 Equipment Characterization

In order to verify the 1μA, 10μA, 100μA, 1mA and 10mA source and measure ranges of the Model 238, the 0.9μA, 9μA, 90μA, 0.9mA and 9mA outputs of the Model 263 are characterized.

1. Connect the Model 263 source, Model 193A DMM and Model 8006 test fixture as shown in Figure 1-1. Install the 100kΩ resistor (in Table 1-1) in the AXIAL KELVIN CLIPS test socket of the test fixture.
2. Configure the source and DMM as follows:

Model 263 – Amps function, +0.90000μA on 2μA range, GUARD enabled and output in standby.  
Model 193A – Ohms function on the 200kΩ range.

3. Zero the Model 193A as follows:
  - A. At the SENSE 1 (HI) terminal of the test socket, disconnect the jumper whose other end is connected to BINDING POST 2 on the Signal Panel.
  - B. Connect that jumper to the SENSE 2 (LO) terminal of the test socket. This shorts the Ohms Sense input of the Model 193A at the test socket.
  - C. On the Model 193A, enable ZERO to cancel test lead resistance.
  - D. Relocate the jumper back to the SENSE 1 terminal of the test socket. Make sure the connections at the Component Test Module are correct as shown in Figure 1-1.
4. In the space provided below, use a pencil to record the actual value of the 100kΩ resistor from the display of the Model 193A.

$$R_{100k\Omega} = \text{_____} \text{ k}\Omega$$

5. Set the Model 193A to the DCV function and the 200mV range, and disable zero.
6. To cancel any offset, zero the Model 193A by shorting its input (VOLTS HI to LO) and enabling zero.
7. Remove the short from the input of the Model 193A and place the short on the input of the Model 193A and place the Model 263 in operate to source +0.90000μA to the 100kΩ resistor
8. In the space below, use a pencil to record the voltage drop across the resistor from the display of the Model 193A.

$$V_{100k\Omega} = \text{_____} \text{ mV}$$

9. Calculate (to 5-1/2 digits) the current through the 100kΩ resistor as follows:

$$I_{0.9\mu A} = \frac{V_{100k\Omega}}{R_{100k\Omega}} = \text{_____} \mu A$$

$I_{0.9\mu A}$  is the characterized current for the 2μA range of the Model 263. It is used to check the 1μA measurement range of the Model 238. Using a pencil, record the calculated value of  $I_{0.9\mu A}$  in Entry 1 of Table 1-3.

10. Place the Model 263 in standby.
11. Set the Model 193A to the 2V range.
12. Set the Model 263 to source 9.0000μA on the 20μA range and enable operate.
13. As performed in steps 8 and 9, measure the voltage across the 100kΩ resistor and calculate the current.

$$V_{100k\Omega} = \text{_____} \text{ V}$$

$$I_{9\mu A} = \frac{V_{100k\Omega}}{R_{100k\Omega}} = \text{_____} \mu A$$

$I_{9\mu A}$  is the characterized current for the 20μA range of the Model 263. It is used to check the 10μA measurement range of the Model 238. Using a pencil, record the calculated value of  $I_{9\mu A}$  in Entry 2 of Table 1-3.

14. Place the Model 263 in standby.
15. In the test fixture, remove the 100kΩ resistor and install the 1kΩ resistor (R-263-1k).
16. On the Model 193A, select the Ohms function, 2kΩ range and disable zero.
17. Repeat step 3 to zero the Model 193A.
18. Measure and record the value of the 1kΩ resistor.

$$R_{1k\Omega} = \text{_____} \text{ k}\Omega$$

19. Set the Model 193A to DCV and the 200mV range, and disable zero.
20. To cancel any offset, zero the Model 193A by shorting its input (VOLTS HI to LO) and enabling zero.
21. Remove the short from the input of the Model 193A and set the Model 263 to source 90.000μA on the 200μA range and enable operate.





22. Record the voltage measurement from the Model 193A and calculate the current.

$$V_{1k\Omega} = \text{_____ mV}$$

$$I_{90\mu A} = \frac{V_{1k\Omega}}{R_{1k\Omega}} = \text{_____ } \mu A$$

$I_{90\mu A}$  is the characterized current for the 200 $\mu A$  range of the Model 263. It is used to check the 100 $\mu A$  measurement range of the Model 238. Using a pencil, record the calculated value of  $I_{90\mu A}$  in Entry 3 of Table 1-3.

23. Place the Model 263 in standby.  
24. Set the Model 193A to the 2V range.  
25. Set the Model 263 to source 0.90000mA on the 2mA range, and enable operate.  
26. Record the voltage measurement from the Model 193A and calculate the current.

$$V_{1k\Omega} = \text{_____ V}$$

$$I_{0.9mA} = \frac{V_{100\Omega}}{R_{100\Omega}} = \text{_____ mA}$$

$I_{0.9mA}$  is the characterized current for the 2mA range of the Model 263. It is used to check the 1mA measurement range of the Model 238. Using a pencil, record the calculated value of  $I_{0.9mA}$  in Entry 4 of Table 1-3.

27. Place the Model 263 in standby.  
28. In the test fixture, remove the 1k $\Omega$  resistor and install the 100 $\Omega$  resistor (R-249-100).  
29. On the Model 193A, select the Ohms function, 200 $\Omega$  range and disable zero.  
30. Repeat step 3 to zero the Model 193A.  
31. Measure and record the value of the 100 $\Omega$  resistor.

$$R_{100\Omega} = \text{_____ } \Omega$$

32. Set the Model 193A to DCV and the 2V range, and disable zero.  
33. To cancel any offset, zero the Model 193A by shorting its input (VOLTS HI to LO) and enabling zero.  
34. Remove the short from the input of the Model 193A and set the Model 263 to source 9.0000mA on the 20mA range and enable operate.  
35. Record the voltage measurement from the Model 193A and calculate the current.

$$V_{100\Omega} = \text{_____ } \Omega$$

$$I_{9mA} = \frac{V_{100\Omega}}{R_{100\Omega}} = \text{_____ mA}$$

$I_{9mA}$  is the characterized current for the 20mA range of the Model 263. It is used to check the 10mA measurement range of the Model 238. Using a pencil, record the calculated value of  $I_{9mA}$  in Entry 5 of Table 1-3.

36. Place the Model 263 in standby.

Table 1-3 Model 263 I-Source Characterization

Entry	263 I-Source		Characterized I-Source Value	I-Source Value Limits*
	Range	Programmed Value		
1	2 $\mu A$	0.90000 $\mu A$	$I_{0.9\mu A} = \text{_____}$	0.9 $\mu A \pm 450pA$
2	20 $\mu A$	9.0000 $\mu A$	$I_{9\mu A} = \text{_____}$	9 $\mu A \pm 4.3nA$
3	200 $\mu A$	90.000 $\mu A$	$I_{90\mu A} = \text{_____}$	90 $\mu A \pm 45nA$
4	2mA	0.90000mA	$I_{0.9mA} = \text{_____}$	0.9mA $\pm 430nA$
5	20mA	9.0000mA	$I_{9mA} = \text{_____}$	9mA $\pm 5.4\mu A$

\*The characterized I-source values should be within the listed limits. These limits are based on 90-day specifications of the Models 263 and 193A. A characterized value that does not fall within these limits indicates a calculation error, or that the Model 263 and/or Model 193A is out of specification.





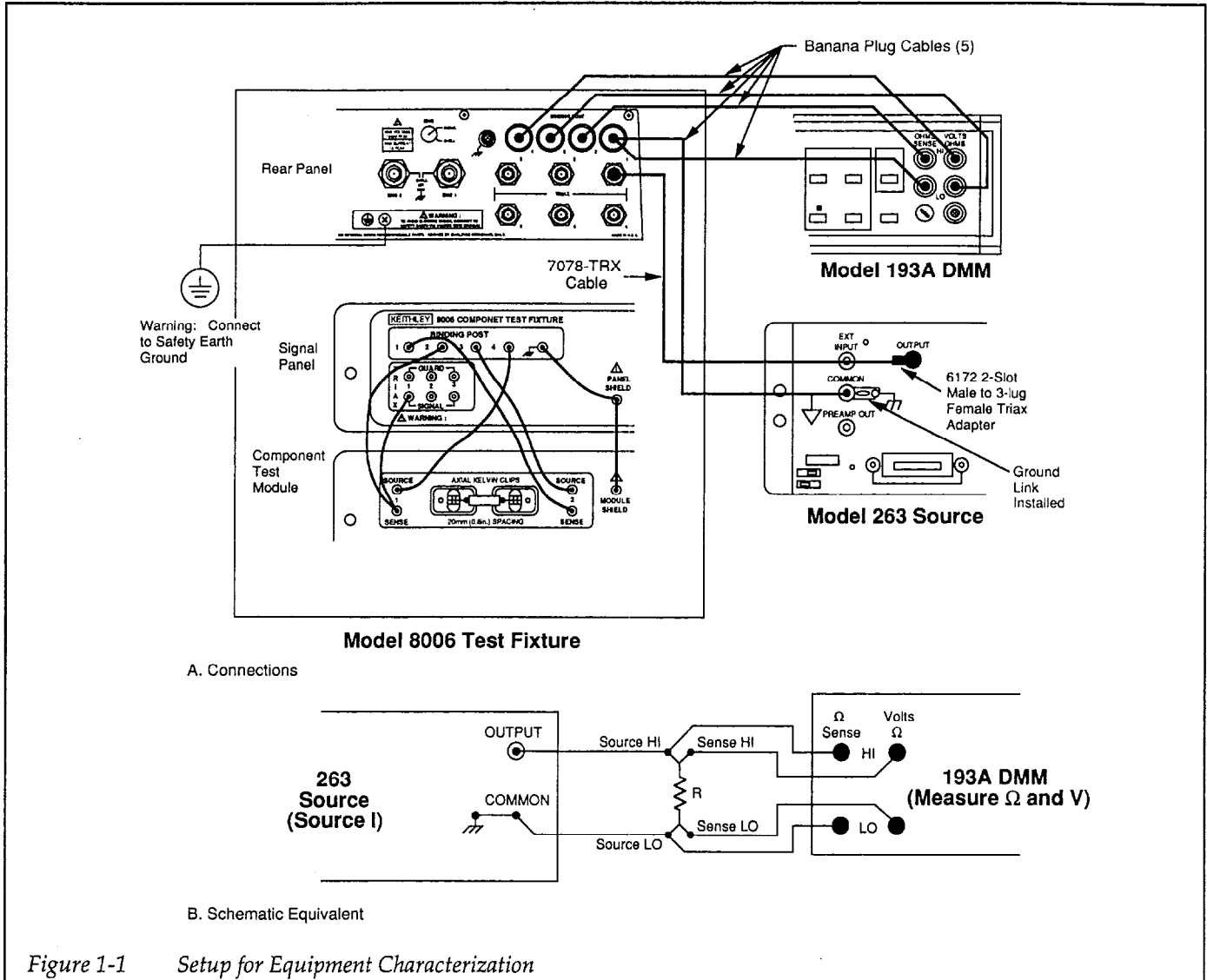

Figure 1-1 Setup for Equipment Characterization





### 1.5.2 Common Mode Verification

Set up the equipment as shown in Figure 1-2 and perform the following steps for common mode verification.

1. While in standby, program the Model 238 as follows;  
 TIME at LINECYCLE PERIOD, source at +1.0000 $\mu$ A, and compliance at 1V on the 1.5V range.

2. Place the Model 238 in OPERATE and, using a pencil, record the voltage measurement in the space provided below.

$$V_{+1\mu A} = \underline{\hspace{2cm}} \text{ V}$$

3. From the keypad, change the source value to -1.0000 $\mu$ A and record that measurement.

$$V_{-1\mu A} = \underline{\hspace{2cm}} \text{ V}$$

4. Subtract the two voltage measurements from each other. Verify that the absolute value of the result is <1.20mV

$$|V_{+1\mu A} - V_{-1\mu A}| < 1.20\text{mV}$$

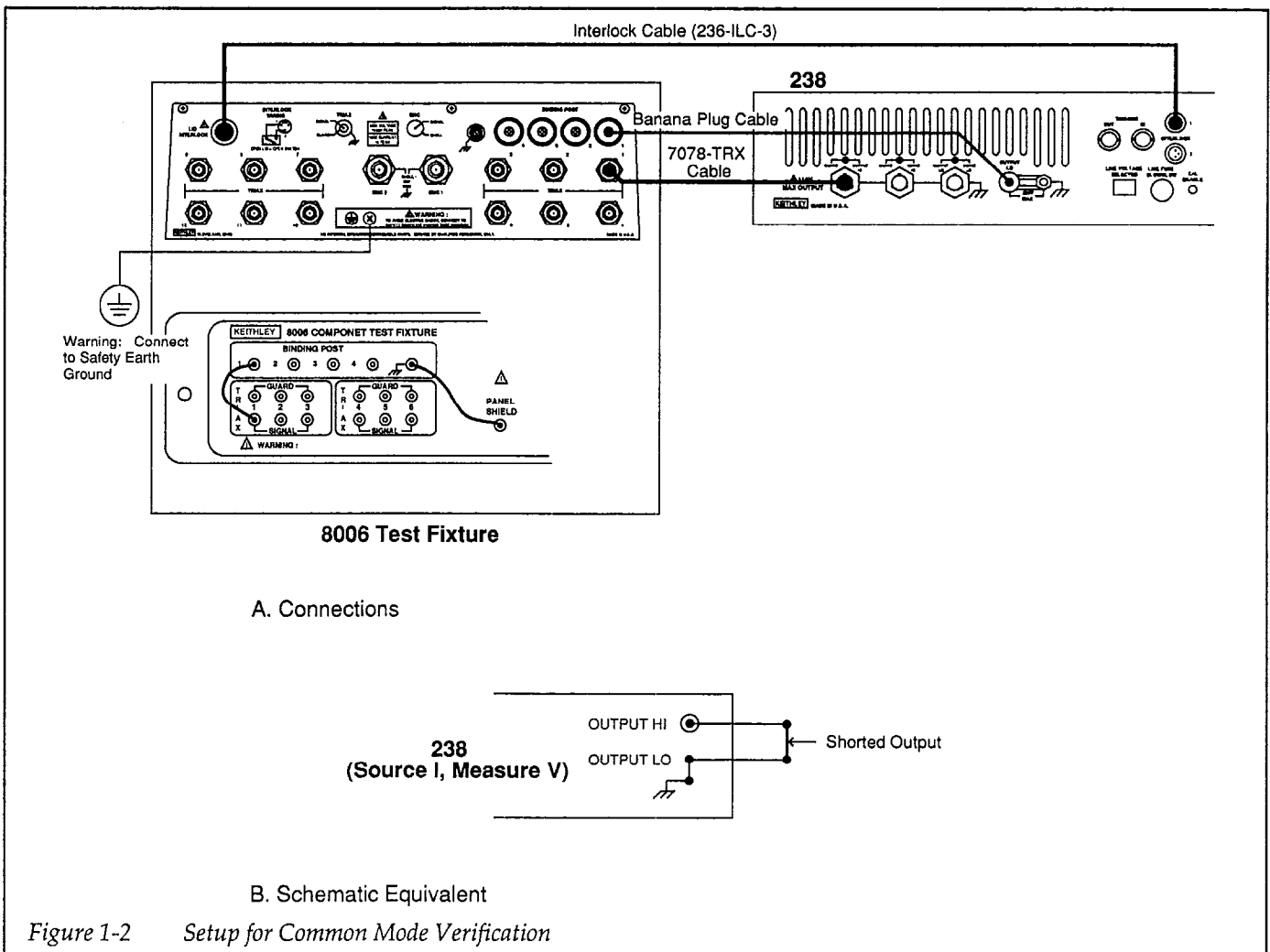

Figure 1-2 Setup for Common Mode Verification



### 1.5.3 Voltage Source Verification

Set up the equipment as shown in Figure 1-3 and perform the following steps to verify the voltage source.

#### WARNING

The following procedure uses hazardous voltages (100V) that could cause injury or death. Exercise extreme caution when encountering these lethal voltage levels.

1. Set the Model 193A to measure DCV on the 200mV range.
2. While in standby, set the Model 238 to source 0V on the 1.5V range and set compliance to 10mA.
3. Temporarily disconnect the banana cable from BINDING POST 2 at the rear panel of the test fixture and connect it to VOLTS LO of the Model 193A. This will short the input of the Model 193A DMM.
4. On the Model 193A, press ZERO to cancel any measurement offsets.
5. Reconnect the banana cable to BINDING POST 2 of the test fixture.
6. Place the Model 238 in operate and verify that the reading on the DMM is within the limits shown in the first entry of Table 1-4. Use the filter if the reading is noisy.
7. Press the SELECT ◀ button to select the 15V range and verify that the DMM reading is within the allowable limits in Table 1-4.
8. Using Table 1-4 as a guide, repeat step 7 to check the 0V output on the 110V range.
9. From the keypad, program the Model 238 to source +1V on the 1.5V range and verify that reading on the 193A DMM is within the allowable limits.
10. Repeat step 9 for a source value of -1V.
11. Using Table 1-4 as a guide, check source values of  $\pm 10V$  and  $\pm 100V$ .
12. Program the Model 238 to 0V and place it in standby.

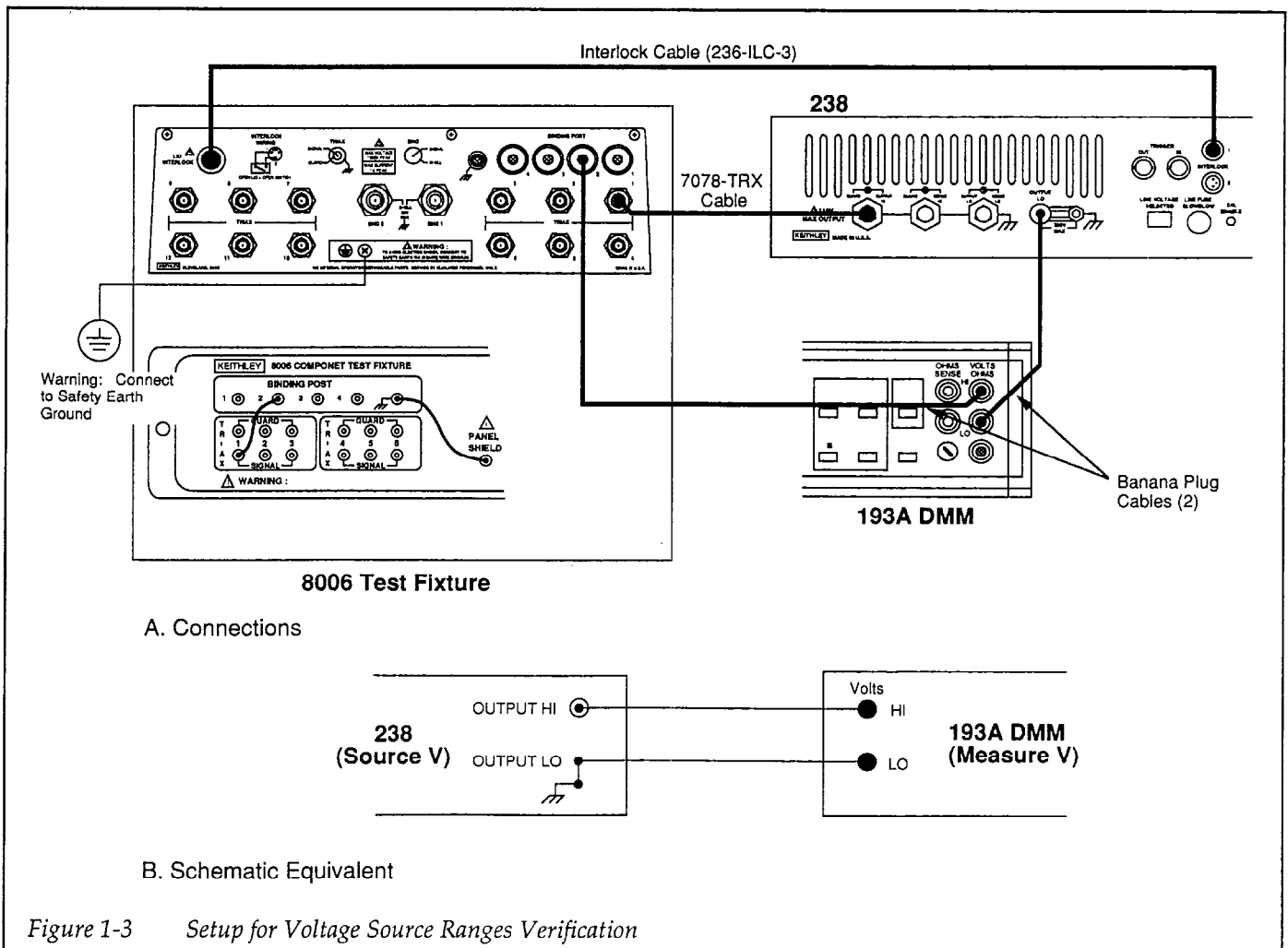

Figure 1-3 Setup for Voltage Source Ranges Verification



Table 1-4 Voltage Source Verification

238 Source Value*	238 Source Range	193A Range	Allowable Reading on Model 193A (18°C to 28°C)
0V	1.5V	200mV	-0.800mV to +0.800mV
0V	15V	200mV	-2.700mV to +2.700mV
0V	110V	200mV	-24.000mV to +24.000mV
1.0V	1.5V	2V	+0.99887V to +1.00113V
-1.0V	1.5V	2V	-0.99887V to -1.00113V
10V	15V	20V	+9.9940V to +10.0060V
-10V	15V	20V	-9.9940V to -10.0060V
100V	110V	200V	+99.943V to +100.057V
-100V	110V	200V	-99.943V to -100.057V

\*Current compliance is set to 10mA

### 1.5.4 Voltage Measure Verification

Set up the equipment shown in Figure 1-4 and perform the following steps to verify voltage measurement:

**WARNING**

The following procedure uses hazardous voltages (100V) that could cause injury or death. Exercise extreme caution when encountering these lethal voltage levels.

1. While in standby, configure the Model 238 to measure volts by setting it to source 0nA on the 1nA current source range.
2. While in standby, set the Model 343A calibrator to output 0V on the 10V range.
3. On the Model 238, set voltage compliance to 1.5V on the 1.5V measurement range.
4. Place the calibrator and the Model 238 in operate.
5. Verify that the measured voltage reading on the Model 238 is within the allowable limits listed in the first entry of Table 1-5.
6. On the Model 238, change the compliance limit to 15V on the 15V measurement range and verify that the voltage reading is within the limits in the table.
7. Using Table 1-5 as a guide, repeat step 6 to measure 0V on the 110V range.
8. Set the calibrator to output +1V on the 10V range, and set the Model 238 for a compliance limit of 1.5V on the 1.5V measurement range. Verify that the voltage reading on the Model 238 is within the allowable limits in the table.
9. Repeat step 8 using a calibrator output of -1V.
10. Using Table 1-5 as a guide, measure calibrator outputs of ±10V and ±100V.
11. Place the Model 238 in standby.



Table 1-5 Voltage Measure Verification

343A Range	343A Output	238 Compliance Limit & Measuring Range*	Allowable Reading (18°C to 28°C)
10V	0V	1.5V	-0.00045V to +0.00045V
10V	0V	15V	-00.0013V to +00.0013V
10V	0V	110V	-000.010V to +000.010V
10V	+1V	1.5V	+0.99927V to +1.00073V
10V	-1V	1.5V	-0.99927V to -1.00073V
10V	+10V	15V	+9.9962V to +10.0038V
10V	-10V	15V	-9.9962V to -10.0038V
100V	+100V	110V	+99.965V to +100.035V
100V	-100V	110V	-99.965V to -100.035V

\*238 set to source 0nA on InA source range.

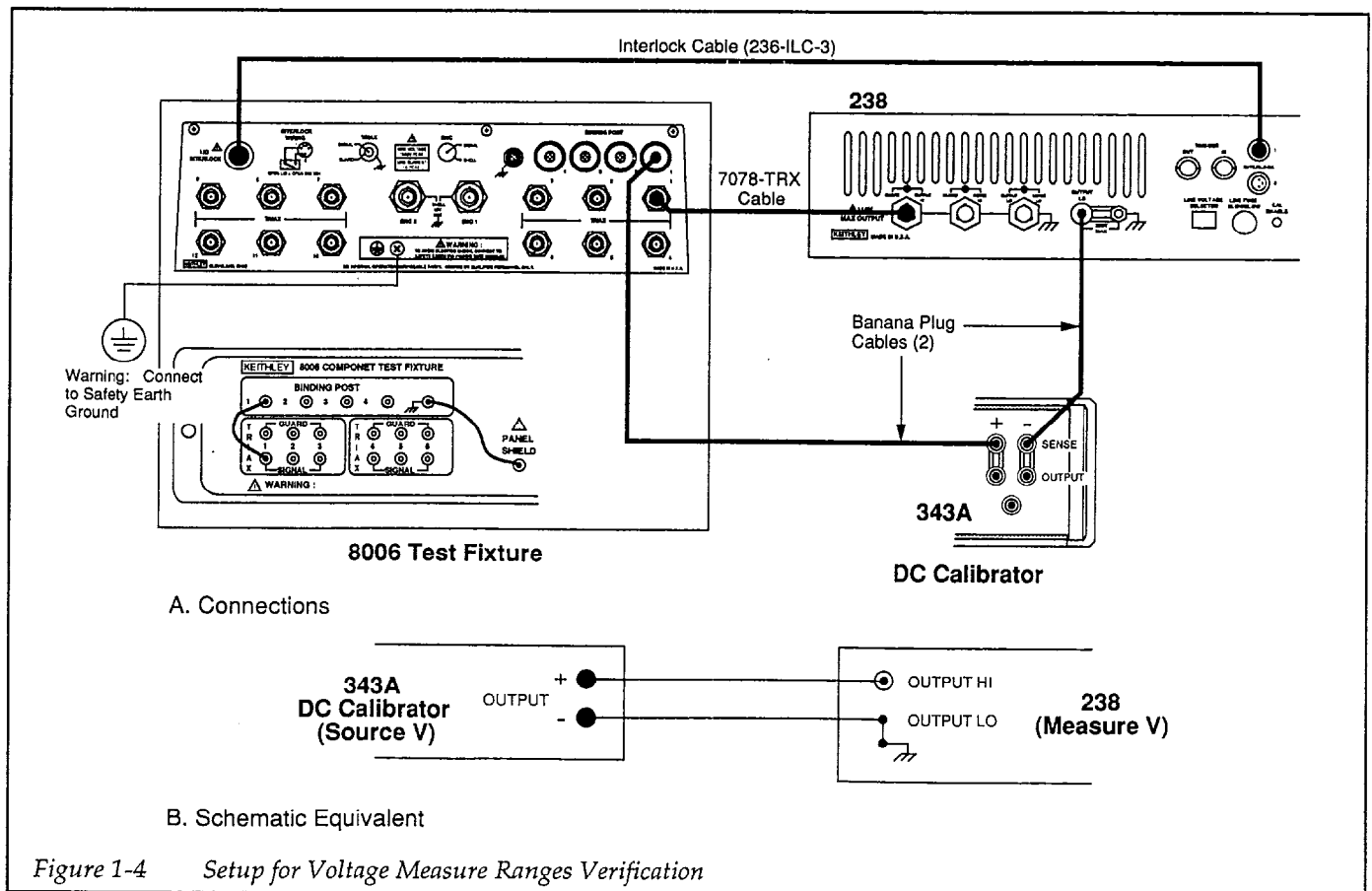

Figure 1-4 Setup for Voltage Measure Ranges Verification



### 1.5.5 Remote Sense Verification

Set up the equipment as shown in Figure 1-5. The 1kΩ resistor (R-263-1k) is installed in the Kelvin test socket. Perform the following steps to verify remote sense accuracy:

**WARNING**

When a Model 238 is programmed for remote sensing, hazardous voltage may be present on the SENSE and OUTPUT terminals when the unit is in operate regardless of the programmed voltage or current. To avoid a possible shock hazard, always turn off all power before connecting or disconnecting cables to the Source Measure Unit or the associated test fixture.

1. While in standby, place the Model 238 in remote sense and set it to source 10V with a compliance limit of 10mA on the 10mA measurement range. Place the Model 238 in standby.
2. Set the Model 193A DMM to DCV and select the 20V range.
3. Temporarily disconnect the banana cable from VOLTS HI of the DMM at the rear panel of the test fixture (BINDING POST 1), and connect it to VOLTS LO of the DMM. This shorts the input of the Model 193A DMM.
4. On the Model 193A DMM, enable zero to cancel any offsets.
5. Re-connect the banana cable to BINDING POST 1 of the test fixture.
6. Place the Model 238 in operate and verify that the reading on the DMM is within the following allowable limit; 9.9940V to 10.0060V.
7. Place the Model 238 in standby and local sense.

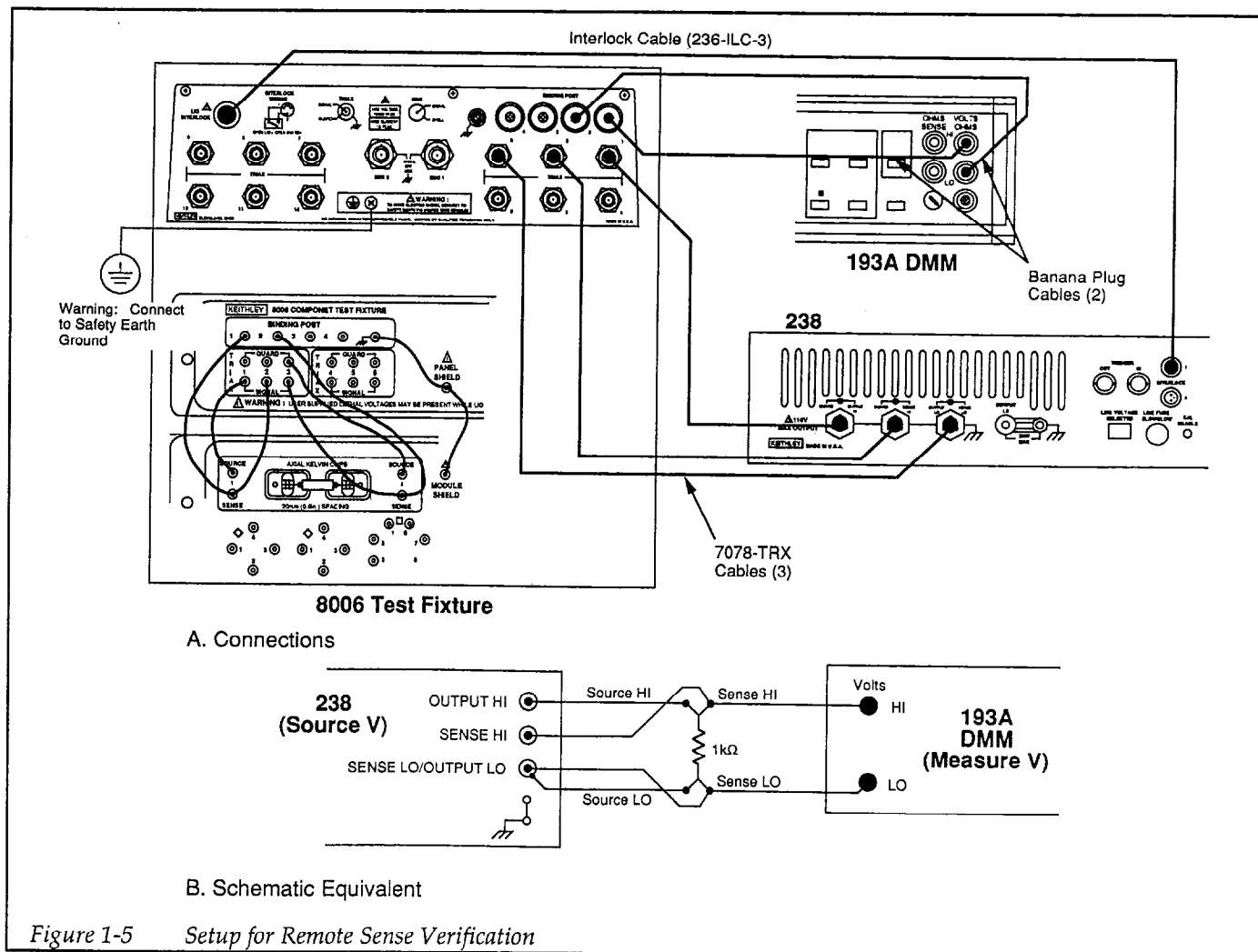

Figure 1-5 Setup for Remote Sense Verification



### 1.5.6 Low Current (1nA to 10mA) Measure Ranges Verification

Set up the equipment as shown in Figure 1-6 and perform the following steps to verify the 1nA to 10mA measure ranges:

1. Use Table 1-6 to calculate the allowable readings for the 1mA through 10mA ranges. The values for  $I_{0.9\mu A}$ ,  $I_{9\mu A}$ ,  $I_{90\mu A}$ ,  $I_{0.9mA}$  and  $I_{9mA}$  were previously calculated and recorded in Table 1-3. After calculating these readings, transfer them to Table 1-7.
2. While in standby, configure the Model 238 to measure current by setting it to source 0V on the 1.5V source range.
3. While in standby, set the Model 263 to the 2nA range and enable guard.
4. Set the compliance limit of the Model 238 to 1nA on the 1nA measurement range and enable operate.
5. Verify that the current measurement on the Model 238 is within the allowable limits listed in the first entry of Table 1-7.
5. On the Model 238, change the compliance limit to 10nA on the 10nA measurement range. Verify that the reading on this measurement range is within the limits specified in the table.
6. Using Table 1-7, check the rest of the Model 238 current ranges with the output of the Model 263 in standby.
7. Set the Model 263 to output +0.90000nA on the 2nA range, and set the Model 238 compliance limit to 1nA on the 1nA measurement range.
8. Verify that the reading is within the limits specified in the table.
9. On the Model 263, change the output to negative polarity and verify that the reading is within the limits specified in the table.
10. Using Table 1-7 as a guide, check the 10nA through 10mA measurement ranges of the Model 238.
11. Place the Model 263 in standby.

Table 1-6 Allowable Reading Calculations for Low Current Measure Verification (1 $\mu$ A to 10mA)

238 Measure Range	Reading Calculations*	Allowable Reading**		Typical Limits***
		Lower Limit	Upper Limit	
1 $\mu$ A	$+I_{0.9\mu A} \pm [ (0.0004) I_{0.9\mu A} + 60pA ] =$ $-I_{0.9\mu A} \pm [ (0.0004) I_{0.9\mu A} + 60pA ] =$	+ . . . . . $\mu A$ - . . . . . $\mu A$	+ . . . . . $\mu A$ - . . . . . $\mu A$	+0.90000 $\mu A$ $\pm 870pA$ -0.90000 $\mu A$ $\pm 870pA$
10 $\mu$ A	$+I_{9\mu A} \pm [ (0.00035) I_{9\mu A} + 700pA ] =$ $-I_{9\mu A} \pm [ (0.00035) I_{9\mu A} + 700pA ] =$	+ . . . . . $\mu A$ - . . . . . $\mu A$	+ . . . . . $\mu A$ - . . . . . $\mu A$	+9.0000 $\mu A$ $\pm 8nA$ -9.0000 $\mu A$ $\pm 8nA$
100 $\mu$ A	$+I_{90\mu A} \pm [ (0.00035) I_{90\mu A} + 6nA ] =$ $-I_{90\mu A} \pm [ (0.00035) I_{90\mu A} + 6nA ] =$	+ . . . . . $\mu A$ - . . . . . $\mu A$	+ . . . . . $\mu A$ - . . . . . $\mu A$	+90.000 $\mu A$ $\pm 83nA$ -90.000 $\mu A$ $\pm 83nA$
1mA	$+I_{0.9mA} \pm [ (0.00035) I_{0.9mA} + 60nA ] =$ $-I_{0.9mA} \pm [ (0.00035) I_{0.9mA} + 60nA ] =$	+ . . . . . mA - . . . . . mA	+ . . . . . mA - . . . . . mA	+0.90000mA $\pm 800nA$ -0.90000mA $\pm 800nA$
10mA	$+I_{9mA} \pm [ (0.00038) I_{9mA} + 600nA ] =$ $-I_{9mA} \pm [ (0.00038) I_{9mA} + 600nA ] =$	+ . . . . . mA - . . . . . mA	+ . . . . . mA - . . . . . mA	+9.0000mA $\pm 9.4\mu A$ -9.0000mA $\pm 9.4\mu A$

\*  $I_{0.9\mu A}$ ,  $I_{9\mu A}$ ,  $I_{90\mu A}$ ,  $I_{0.9mA}$ , and  $I_{9mA}$  are obtained from Table 1-3

\*\* Allowable reading limits are to be transferred to Table 1-7.

\*\*\* The calculated allowable readings should be within listed typical limits. These limits are based on the 90-day specifications of the Model 263 and 193A. A calculated allowable reading that does not fall within these limits indicates a calculation error, or that the Model 263 and/or Model 193A is out of specification.

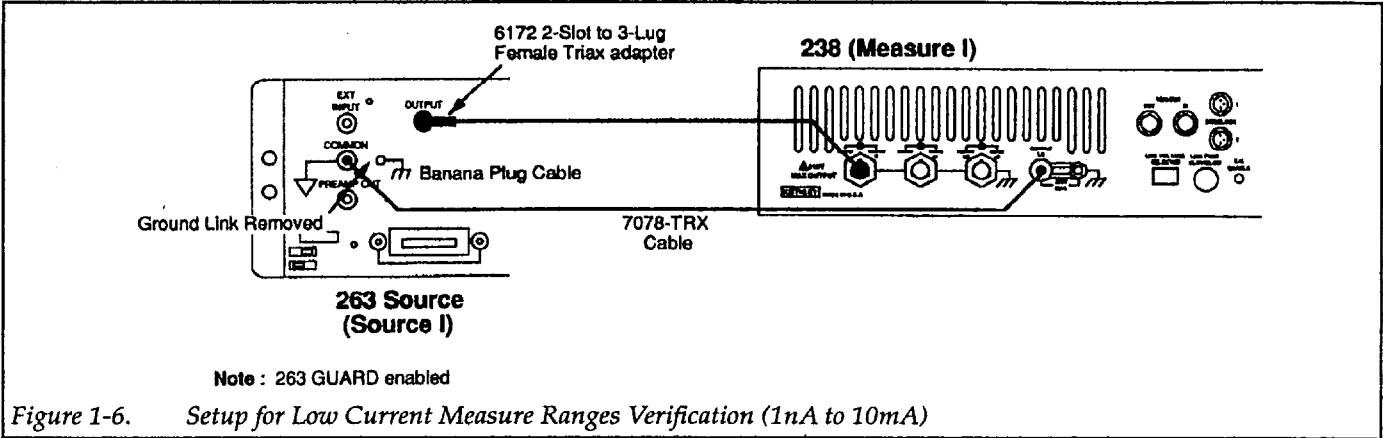

Figure 1-6. Setup for Low Current Measure Ranges Verification (1nA to 10mA)

Table 1-7 Low Current Measure Verification (1nA to 10mA)

263 Range	263 Output	238 Compliance Limit & Measure Range*	Allowable Readings** (18°C to 28°C)
2nA	Standby	1nA	-0.00010nA to +0.00010nA
2nA	Standby	10nA	-00.0010nA to +00.0010nA
2nA	Standby	100nA	-000.006nA to +000.006nA
2nA	Standby	1μA	-0.00006μA to +0.00006μA
2nA	Standby	10μA	-00.0007μA to +00.0007μA
2nA	Standby	100μA	-000.006μA to +000.006μA
2nA	Standby	1mA	-0.00006mA to +0.00006mA
2nA	Standby	10mA	-00.0006mA to +00.0006mA
2nA	+0.90000nA	1nA	-0.89720nA to -0.90280nA
2nA	-0.90000nA	1nA	+0.89720nA to +0.90280nA
20nA	+9.0000nA	10nA	-8.9720nA to -9.0280nA
20nA	-9.0000nA	10nA	+8.9720nA to +9.0280nA
200nA	+90.000nA	100nA	-89.805nA to -90.195nA
200nA	-90.000nA	100nA	+89.805nA to +90.195nA
2μA	+0.90000μA	1μA	- _____ to - _____
2μA	-0.90000μA	1μA	+ _____ to + _____
20μA	+9.0000μA	10μA	- _____ to - _____
20μA	-9.0000μA	10μA	+ _____ to + _____
200μA	+90.000μA	100μA	- _____ to - _____
200μA	-90.000μA	100μA	+ _____ to + _____
2mA	+0.90000mA	1mA	- _____ to - _____
2mA	-0.90000mA	1mA	+ _____ to + _____
20mA	+9.0000mA	10mA	- _____ to - _____
20mA	-9.0000mA	10mA	+ _____ to + _____

\*238 set to source 0V on the 1.5V source range.

\*\*Allowable readings for the 1μA through 10mA ranges are calculated in Table 1-6.







Table 1-9 Low Current Source Verification (1nA to 10mA)

617 Range	263 I-Source		238 I-Source*		617 Allowable Ratings** (18°C to 28°C)	
	Range	Output Setting	Source Range	Source Value***		
2pA	2nA	Standby	1nA	0nA	-0.4500pA	to +0.4500pA
2pA	2nA	Standby	10nA	0nA	-2.000pA	to +2.000pA
20pA	2nA	Standby	100nA	0nA	-20.00pA	to +20.00pA
200pA	2nA	Standby	1µA	0µA	-200.0pA	to +200.0pA
2nA	2nA	Standby	10µA	0µA	-2.000nA	to +2.000nA
20nA	2nA	Standby	100µA	0µA	-20.00nA	to +20.00nA
200nA	2nA	Standby	1mA	0mA	-200.0nA	to +200.0nA
2µA	2nA	Standby	10mA	0mA	-2.000µA	to +2.000µA
20pA	2nA	+0.9nA -0.9nA	1nA	-0.9nA +0.9nA	-3.150pA	to +3.150pA
200pA	20nA	+9nA -9nA	10nA	-9nA +9nA	-29.00pA	to +29.00pA
200pA	200nA	+90nA -90nA	100nA	-90nA +90nA	-209.0pA	to +209.0pA
2nA	2µA	+0.9µA -0.9µA	1µA	-I <sub>0.9µA</sub> +I <sub>0.9µA</sub>	-_____nA	to +_____nA
20nA	20µA	+9µA -9µA	10µA	-I <sub>9µA</sub> +I <sub>9µA</sub>	-_____nA	to +_____nA
200nA	200µA	+90µA -90µA	100µA	-I <sub>90µA</sub> +I <sub>90µA</sub>	-_____nA	to +_____nA
2µA	2mA	+0.9mA -0.9mA	1mA	-I <sub>0.9mA</sub> +I <sub>0.9mA</sub>	-_____nA	to +_____nA
2µA	20mA	+9mA -9mA	10mA	-I <sub>9mA</sub> +I <sub>9mA</sub>	-_____nA	to +_____nA

\* 238 compliance limit set to 1.1V on the 1.1V measurement range.

\*\* Allowable readings for the 1µA thru 10mA source ranges are calculated in Table 1-8.

\*\*\* For the 1µA thru 10mA ranges, program the Model 238 to source the characterized I-source values from Table 1-3.



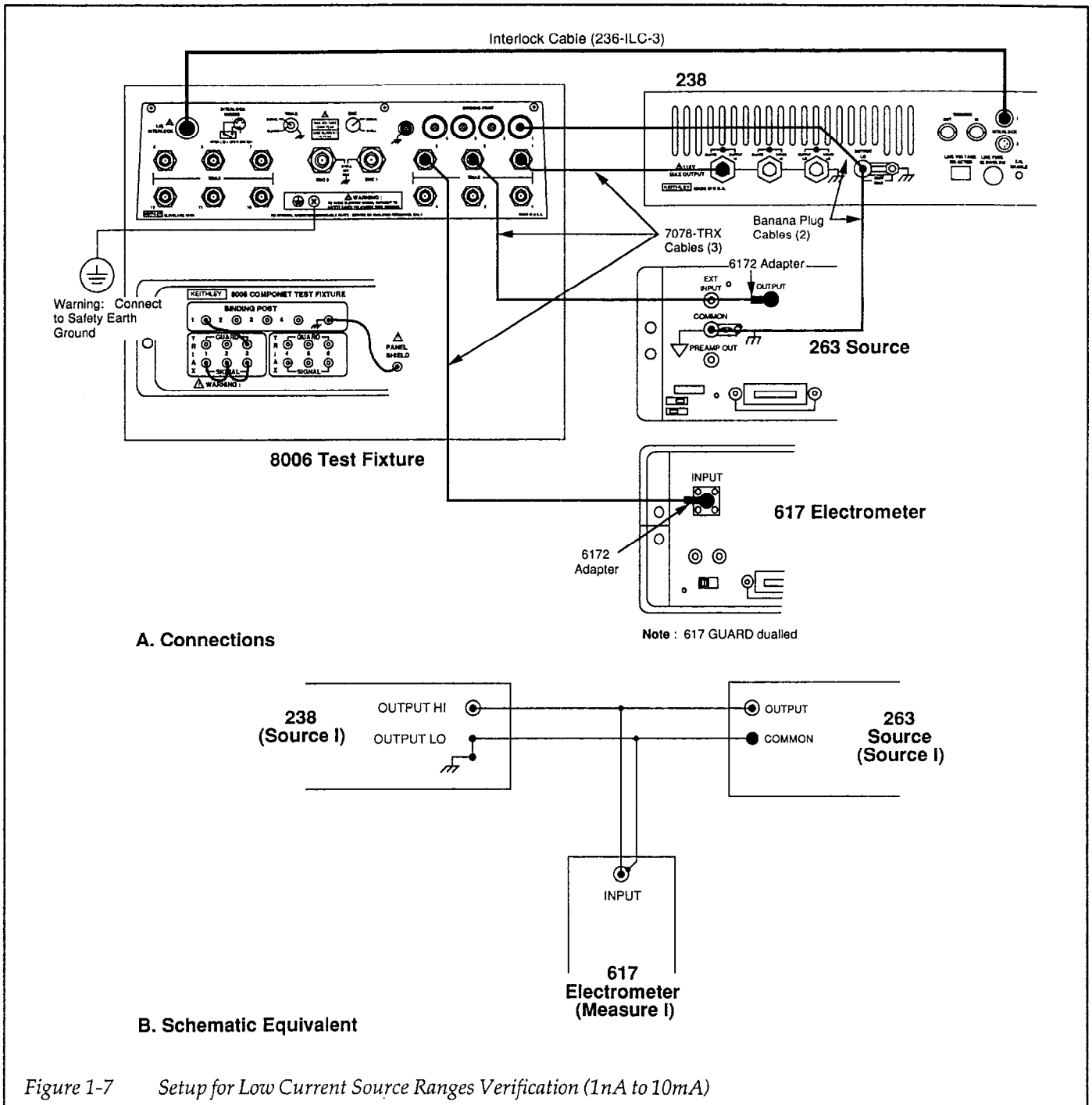

Figure 1-7 Setup for Low Current Source Ranges Verification (1nA to 10mA)





### 1.5.8 100mA and 1A Measure Ranges Verification

Set up the equipment as shown in Figure 1-8. A copper short is installed in the test socket.

#### 100mA Measure Range Verification

Perform the following steps to verify the 100mA measurement range:

1. While in standby, set the Model 238 to source 0V on the 1.5V source range, and set compliance to 100mA.
2. Remove the short from the test fixture and place the Model 238 in standby.
3. Verify that the current reading ( $I_{238}$ ) on the Model 238 is within the following limits:

$$I_{238} = \pm 6\mu\text{A}$$

4. Place the short in the test fixture socket and set the calibration source to output +90mA.
5. Verify that the current reading ( $I_{238}$ ) on the Model 238 is within the following limits:

$$I_{238} = 89.904\text{mA to } 90.096\text{mA}$$

6. Set the calibration source to output -90mA.
7. Verify that the current reading ( $I_{238}$ ) on the Model 238 is within the following limits:

$$I_{238} = -89.904\text{mA to } -90.096\text{mA}$$

8. Place the Models 343A and 238 in standby.

#### 1A Measure Range Verification

Perform the following steps to verify the 1A measurement range:

1. While in standby, set the Model 238 to source 0V on the 1.5V source range and set compliance to 1A.
2. Remove the short from the test fixture and place the Model 238 in operate.
3. Verify that the current reading ( $I_{238}$ ) on the Model 238 is within the following limits:

$$I_{238} = \pm 300\mu\text{A}$$

4. Place the short in the test fixture and set the calibration source to output +900mA on the 1A range.
5. Verify that the current reading ( $I_{238}$ ) on the Model 238 is within the following limits:

$$I_{238} = 898.62\text{mA to } 901.38\text{mA}$$

6. Set the calibration source to output -900mA.
7. Verify that the current reading ( $I_{238}$ ) on the Model 238 is within the following limits:

$$I_{238} = -898.62\text{mA to } -901.38\text{mA}$$

8. Place the Models 343A and 238 in standby.

### 1.5.9 100mA and 1A Source Ranges Verification

The equipment setup for both 100mA and 1A source verification is shown in Figure 1-9.



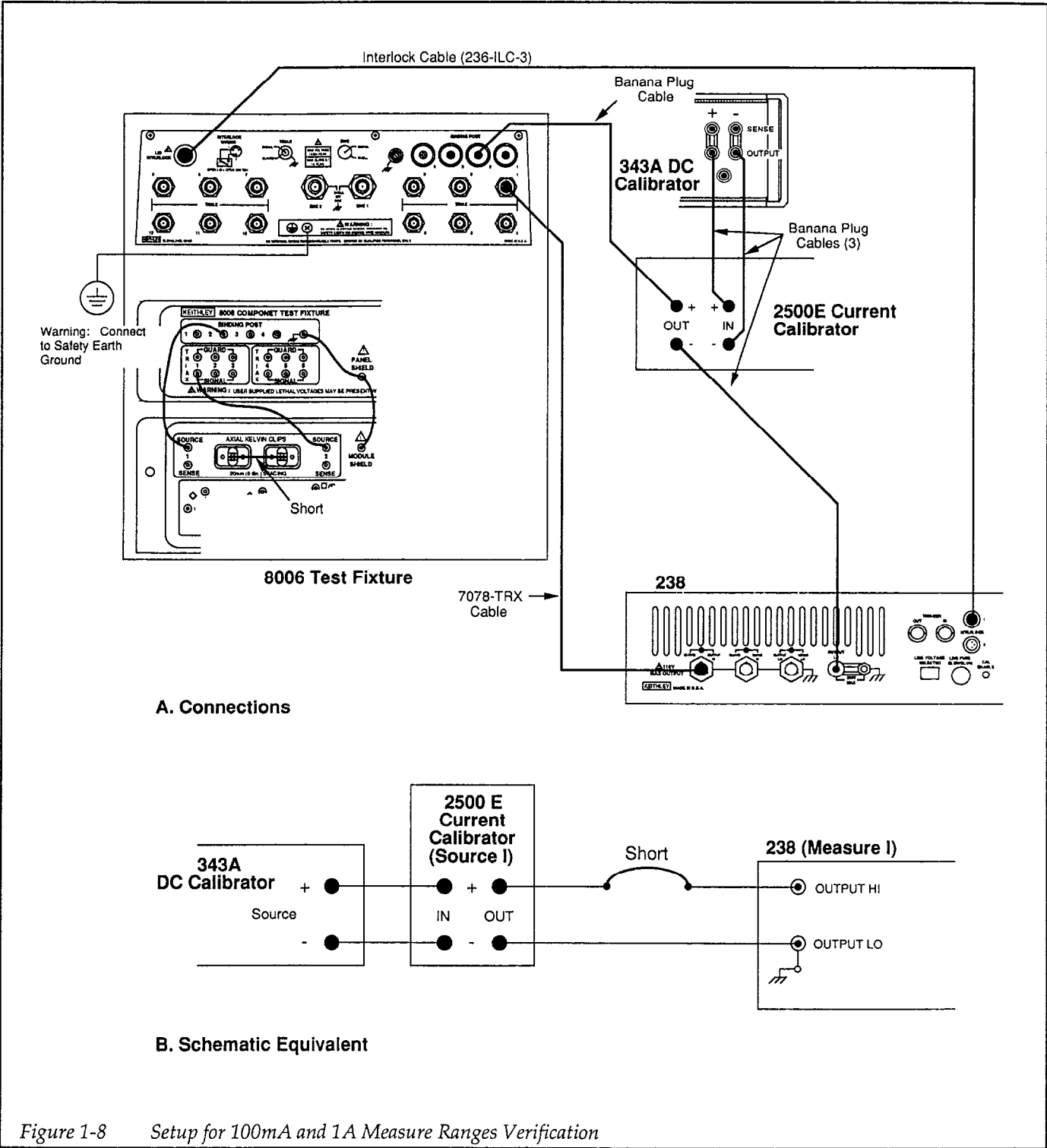

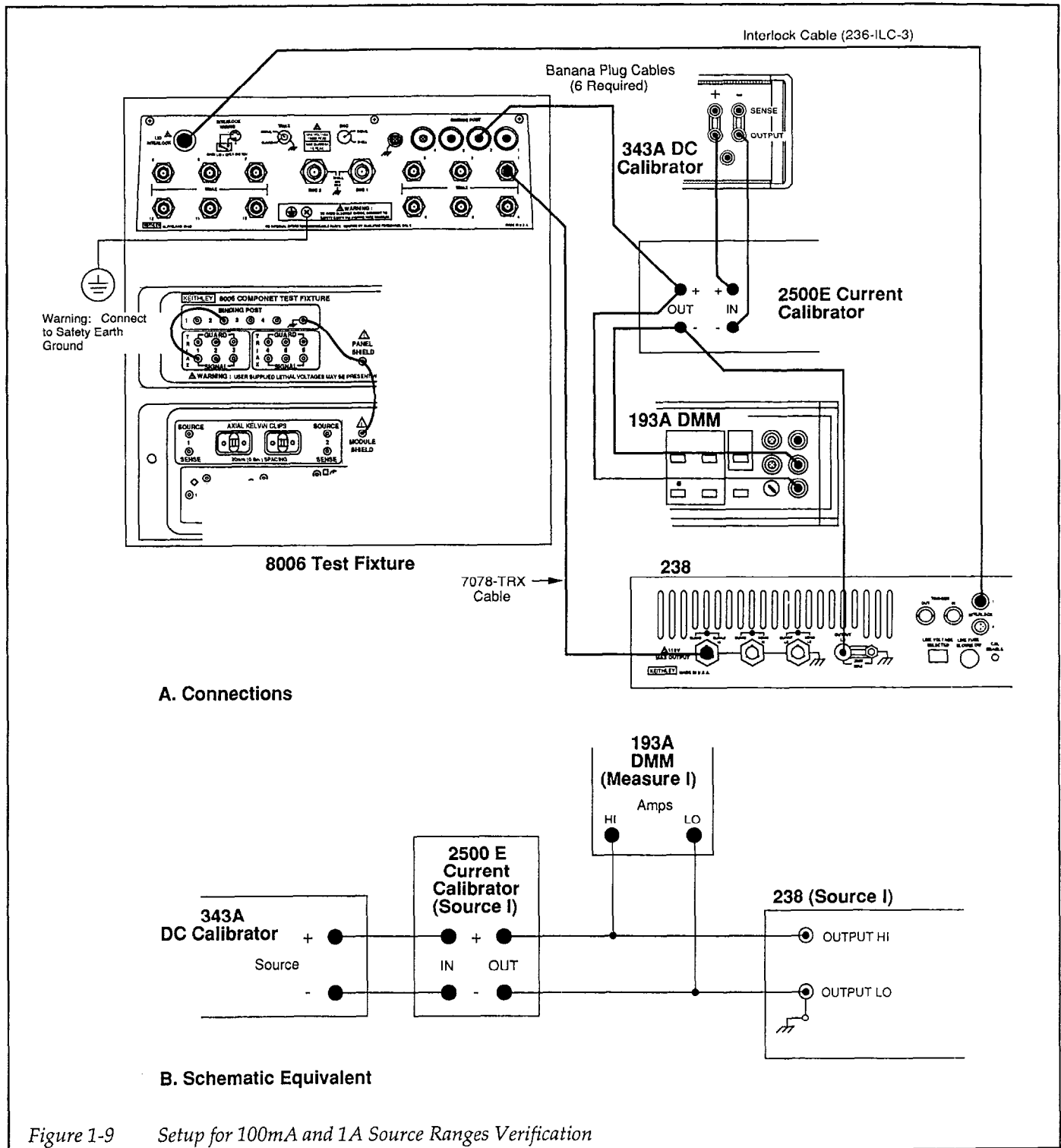

Figure 1-9 Setup for 100mA and 1A Source Ranges Verification



**100mA Source Range Verification**

Perform the following steps to verify the 100mA source range:

1. While in standby, set the Model 238 to source 0mA on the 100mA source range and set compliance to 1.5V.
2. Set the Model 193A to the 200 $\mu$ A range.
3. Set the Model 343A to 0V and place the Model 2500E on the 100 $\mu$ A range.
4. Place the Model 238 in operate and verify that the current measurement on the Model 193A ( $I_{193A}$ ) is within the following limits:

$$I_{193A} = \pm 20\mu\text{A}$$

5. Set the Model 238 to output +90mA, and set the calibration source to output -90mA on the 100mA range.
  6. Verify that the current measurement from the Model 193A ( $I_{193A}$ ) is within the following limits:
- $$I_{193A} = \pm 0.1100\text{mA}$$
7. Set the Model 238 to output -90mA, and set the calibration source to output +90mA on the 100mA range.
  8. Verify that the current measurement from the Model 193A ( $I_{193A}$ ) is within the following limits:

$$I_{193A} = \pm 0.1100\text{mA}$$

9. Place the Model 238 and the calibration source in standby.

**1A Source Range Verification**

Perform the following steps to verify the 1A source range:

1. While in standby, set the Model 238 to source 0A on the 1A range and set compliance to 1.5V.
2. While in standby, set the Model 343A to 0V and place the Model 2500E on the 1mA range.
3. Place the Models 238 and 343A in operate, and verify that the current reading on the Model 193A ( $I_{193A}$ ) is within the following limits:

$$I_{193A} = \pm 700\mu\text{A}$$

4. Set the Model 238 to output +0.900A and the calibration source to output -0.900A.
5. Verify that the current reading on the Model 193A ( $I_{193A}$ ) is within the following limits:

$$I_{193A} = \pm 1.78\text{mA}$$

6. Set the Model 238 to output -0.900A and the calibration source to output +0.900A.
7. Verify that the current reading on the Model 193A ( $I_{193A}$ ) is within the following limits:

$$I_{193A} = \pm 1.78\text{mA}$$

# SECTION 2

## Calibration

### 2.1 INTRODUCTION

Calibration should be performed every 12 months, or if the performance verification procedure (Section 1) shows that the Model 238 is out of specifications. If any of the calibration steps cannot be performed without error, refer to the troubleshooting information in this manual. If the problem persists, call your Keithley representative or the factory for further information.

Calibration of the Model 238 is performed over the IEEE-488 bus. This section contains the step-by-step calibration procedures, and a program written in Microsoft QuickBASIC that can be used.

Before attempting any of the following procedures, make sure you are familiar with the controls and operation of the Model 238. Refer to the Model 238 Operator's Manual for complete information.

#### WARNING

The procedures in this section are for use only by qualified service personnel. Do not perform these procedures unless qualified to do so. Many of the steps in this section may expose you to potentially lethal voltages that could result in personal injury or death if normal safety precautions are not observed.

### 2.2 RECOMMENDED CALIBRATION EQUIPMENT

Table 2-1 lists recommended calibration equipment. Note that the Models 263 and 193A must be within their 90-day specifications as listed in the table. Alternate equipment may be used as long as their accuracy is at least as good as the specifications listed in Table 2-2.

### 2.3 ENVIRONMENTAL CONDITIONS

Calibration should be performed under laboratory conditions having an ambient temperature of  $23^{\circ}\text{C} \pm 1^{\circ}\text{C}$  and a relative humidity of less than 70%.

### 2.4 WARM-UP PERIOD

#### WARNING

The Source Measure Unit is equipped with a 3-wire power cord that contains a separate ground wire and is designed to be used with grounded outlets. When proper connections are made, instrument chassis is connected to power line ground. Failure to use a grounded outlet may result in injury or death due to electric shock.

Table 2-1 Required Test Equipment

Manufacturer	Model	Description	Specifications
Keithley	263	5-1/2 digit Calibrator/ Source	2nA, 20nA ranges; $\pm(0.0625\% + 10 \text{ counts})$ 200nA range; $\pm(0.035\% + 10 \text{ counts})$
Keithley	193A	5-1/2 digit DMM	200mV, 2V ranges; $\pm(0.005\% + 2 \text{ counts})$ 20V-1000V ranges; $\pm(0.007\% + 1 \text{ count})$ 200 $\Omega$ -200k $\Omega$ ranges; $\pm(0.007\% + 2 \text{ counts})$ 200 $\mu\text{A}$ , 2mA ranges; $\pm(0.09\% + 10 \text{ counts})$
Keithley	8006	Test Fixture	—
Keithley	R-249-100	100 $\Omega$ Resistor	$\pm 0.1\%$ , $\pm 20\text{ppm}/^{\circ}\text{C}$
	R-263-1k	1k $\Omega$ Resistor	$\pm 0.1\%$ , $\pm 10\text{ppm}/^{\circ}\text{C}$
	R-263-100K	100k $\Omega$ Resistor	$\pm 0.1\%$ , $\pm 10\text{ppm}/^{\circ}\text{C}$
Fluke	343A	DC Voltage Calibrator	10-100V ranges; $\pm 0.002\%$
Valhalla	2500E	Current Calibrator	100mA-1A ranges; $\pm 0.025\%$





**Table 2-2 Specifications for Alternate Equipment**

Instrument Type	Required Specifications
DMM	Same as Keithley 193A (see Table 1-1)
Source DC Current	0.9nA, 9nA, 90nA, Same as Keithley 263 (see Table 2-1) 0.9μA; ±180ppm 9μA, 90μA, 900μA, 9mA; ±170ppm 90mA; ±230ppm 0.9mA; ±625ppm

Turn on the Model 238 and allow it to warm up for at least one hour before performing the calibration procedures. If the instrument has been subjected to extremes of temperature or humidity, allow at least one additional hour for the internal temperature to stabilize. Typically, it takes one additional hour to stabilize a unit that is 10°C (18°F) outside the specified temperature range.

## 2.5 CAL LOCK

A switch (CAL LOCK), accessible through the rear panel with a thin shaft screwdriver (see Figure 2-1), is used to prevent inadvertent calibration of the Model 238. CAL LOCK is a two position (in and out) pushbutton switch. With the CAL LOCK switch in the locked "out" position, storage of calibration constants in nonvolatile memory cannot take place. Temporary calibration values can be entered and used with CAL LOCK in the "out" position. However, when power is turned off, the newly entered calibration constants will be lost.

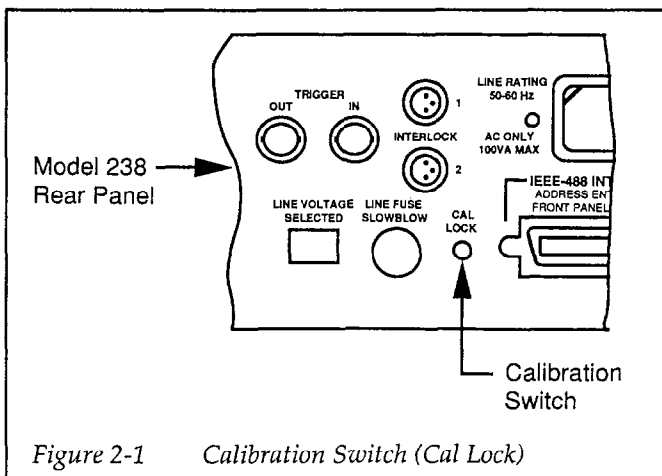

Figure 2-1 Calibration Switch (Cal Lock)

When calibration is performed with CAL LOCK in the unlocked "in" position, calibration constants will be stored in nonvolatile memory when the C59 command is sent over the bus.

## 2.6 CALIBRATION PROCEDURES

The step-by-step procedures for calibrating the Model 238 are provided here. Calibration is divided into three separate procedures that are independent of one another. That is, any or all (in any order) of the three procedures can be performed. The three procedures include; voltage calibration (paragraph 2.6.2), 100mA and 1A calibration (paragraph 2.6.3), and low current ranges calibration (paragraph 2.6.4).

Calibration is performed using the "C" command over the IEEE-488 bus. Details concerning the use of the "C" command and other commands are contained in Section 3 of the Model 238 Operator's Manual.

### WARNING

**Lethal voltage (up to 100V) will be connected to the Model 8006 test fixture. To avoid a possible shock hazard, the safety interlock circuit must be connected to the Model 238.**

Connect the test fixture screw to safety earth ground using #18 AWG wire minimum before use. Turn off all power before connecting or disconnecting wires or cables.

Also, keep in mind that GUARD is always enabled. Thus, a lethal voltage on OUTPUT HI is also present on the two GUARD terminals of the Model 238.

### 2.6.1 Equipment Characterization

In order to calibrate the 1μA, 10μA, 100μA, 1mA and 10mA source and measure ranges of the Model 238, the 0.9μA, 9μA, 90μA, 0.9mA and 9mA outputs of the Model 263 are characterized.

1. Connect the Model 263 source, Model 193A DMM and Model 8006 test fixture as shown in Figure 2-2. Install the 100kΩ resistor (in Table 2-1) in the AXIAL KELVIN CLIPS test socket of the test fixture.



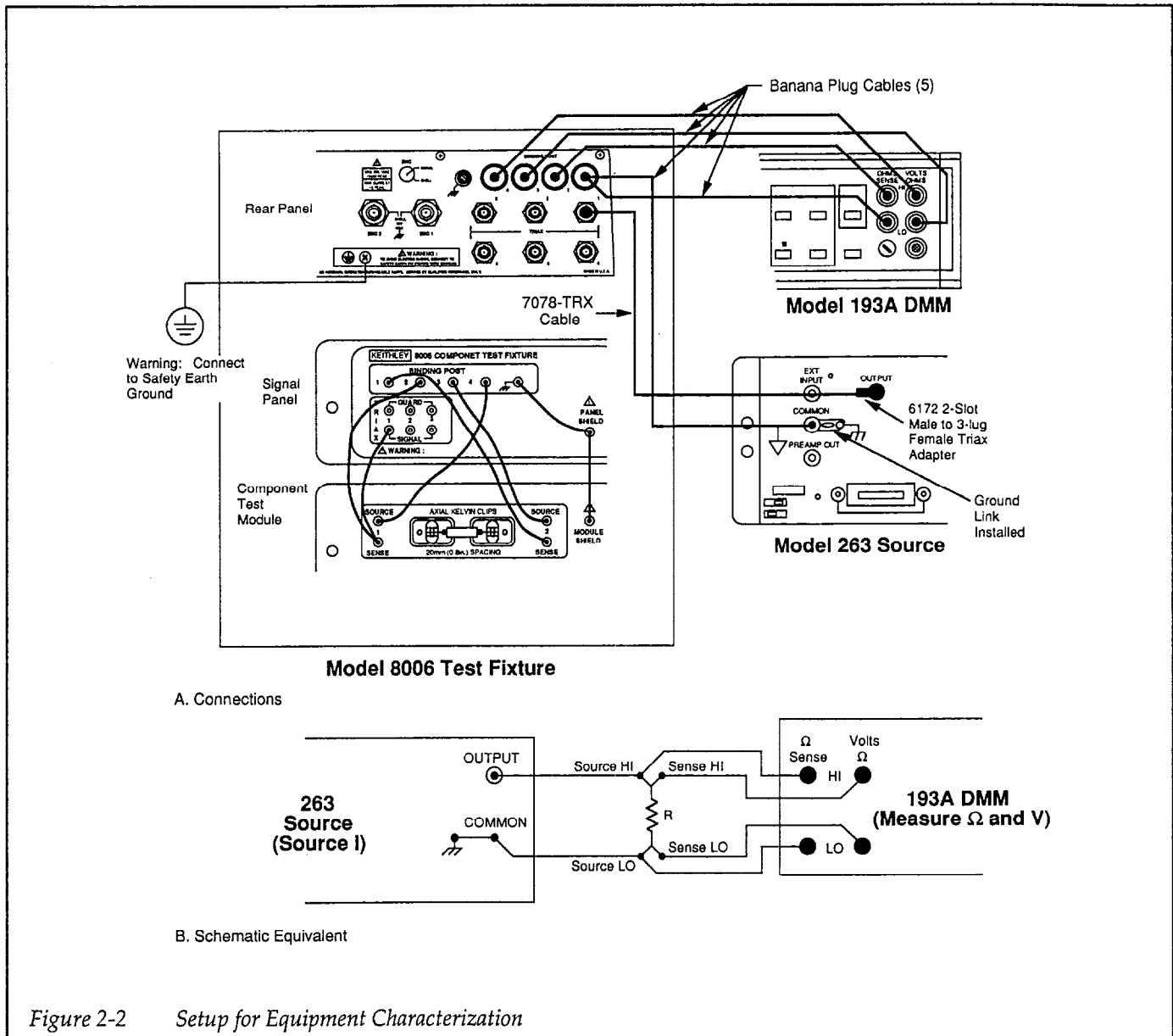

Figure 2-2 Setup for Equipment Characterization

2. Configure the source and DMM as follows:
  - Model 263 – Amps function,  $+0.90000\mu\text{A}$  on  $2\mu\text{A}$  range, Guard enabled and output in standby.
  - Model 193A – Ohms function on the  $200\text{k}\Omega$  range.
3. Zero the Model 193A as follows:
  - A. At the SENSE 1 (HI) terminal of the test socket, disconnect the jumper whose other end is connected to BINDING POST 2 on the Signal Panel.
  - B. Connect that jumper to the SENSE 2 (LO) terminal of the test socket. This shorts the Ohms Sense input of the Model 193A at the test socket.
  - C. On the Model 193A, enable zero to cancel test lead resistance.
  - D. Relocate the jumper back to the SENSE 1 terminal of the test socket. Make sure the connections at the Component Test Module are correct as shown in Figure 2-2.
4. In the space provided below, use a pencil to record the actual value of the  $100\text{k}\Omega$  resistor from the display of the Model 193A:
 
$$R_{100\text{k}\Omega} = \text{_____} \text{ k}\Omega$$
5. Set the Model 193A to the DCV function and the  $200\text{mV}$  range, and disable zero.
6. To cancel any offset, zero the Model 193A by shorting its input (VOLTS HI to LO) and enabling zero.



7. Remove the short from the input of the Model 193A and place the Model 263 in operate to source +0.90000μA to the 100kΩ resistor
8. In the space below, use a pencil to record the voltage drop across the resistor from the display of the Model 193A:

$$V_{100k\Omega} = \underline{\hspace{2cm}} \text{ mV}$$

9. Calculate (to 5-1/2 digits) the current through the 100kΩ resistor as follows:

$$I_{0.9\mu A} = \frac{V_{100k\Omega}}{R_{100k\Omega}} = \underline{\hspace{2cm}} \mu A$$

$I_{0.9\mu A}$  is the characterized current for the 2μA range of the Model 263. It is used to calibrate the 1μA range of the Model 238. Using a pencil, record the calculated value of  $I_{0.9\mu A}$  in Entry 1 of Table 2-3.

10. Place the Model 263 in standby.
11. Set the Model 193A to the 2V range.
12. Set the Model 263 to source 9.0000μA on the 20μA range and enable operate.
13. As performed in steps 8 and 9, measure the voltage across the 100kΩ resistor and calculate the current:

$$V_{100k\Omega} = \underline{\hspace{2cm}} \text{ V}$$

$$I_{9\mu A} = \frac{V_{100k\Omega}}{R_{100k\Omega}} = \underline{\hspace{2cm}} \mu A$$

$I_{9\mu A}$  is the characterized current for the 20μA range of the Model 263. It is used to calibrate the 10μA range of the Model 238. Using a pencil, record the calculated value of  $I_{9\mu A}$  in Entry 2 of Table 2-3.

14. Place the Model 263 in standby.
15. In the test fixture, remove the 100kΩ resistor and install the 1kΩ resistor (R-263-1k).
16. On the Model 193A, select the Ohms function, 2kΩ range and disable zero.
17. Repeat step 3 to zero the Model 193A.
18. Measure and record the value of the 1kΩ resistor:

$$R_{1k\Omega} = \underline{\hspace{2cm}} \text{ k}\Omega$$

19. Set the Model 193A to DCV and the 200mV range, and disable zero.
20. To cancel any offset, zero the Model 193A by shorting its input (VOLTS HI to LO) and enabling zero.
21. Remove the short from the input of the Model 193A and set the Model 263 to source 90.000μA on the 200μA range and enable operate.
22. Record the voltage measurement from the Model 193A and calculate the current:

$$V_{1k\Omega} = \underline{\hspace{2cm}} \text{ mV}$$

$$I_{90\mu A} = \frac{V_{1k\Omega}}{R_{1k\Omega}} = \underline{\hspace{2cm}} \mu A$$

$I_{90\mu A}$  is the characterized current for the 200μA range of the Model 263. It is used to calibrate the 100μA range of the Model 238. Using a pencil, record the calculated value of  $I_{90\mu A}$  in Entry 3 of Table 2-3.

23. Place the Model 263 in standby.
24. Set the Model 193A to the 2V range.
25. Set the Model 263 to source 0.90000mA on the 2mA range, and enable operate.
26. Record the voltage measurement from the Model 193A and calculate the current:

$$V_{1k\Omega} = \underline{\hspace{2cm}} \text{ V}$$

$$I_{0.9mA} = \frac{V_{1k\Omega}}{R_{1k\Omega}} = \underline{\hspace{2cm}} \text{ mA}$$

$I_{0.9mA}$  is the characterized current for the 2mA range of the Model 263. It is used to calibrate the 1mA range of the Model 238. Using a pencil, record the calculated value of  $I_{0.9mA}$  in Entry 4 of Table 2-3.

27. Place the Model 263 in standby.
28. In the test fixture, remove the 1kΩ resistor and install the 100Ω resistor (R-249-100).
29. On the Model 193A, select the Ohms function, 200Ω range and disable zero.
30. Repeat step 3 to zero the Model 193A.
31. Measure and record the value of the 100Ω resistor:

$$R_{100\Omega} = \underline{\hspace{2cm}} \Omega$$

32. Set the Model 193A to DCV and the 2V range, and disable zero.
33. To cancel any offset, zero the Model 193A by shorting its input (VOLTS HI to LO) and enabling zero.
34. Remove the short from the input of the Model 193A and set the Model 263 to source 9.0000mA on the 20mA range and enable operate.
35. Record the voltage measurement from the Model 193A and calculate the current:

$$V_{100\Omega} = \underline{\hspace{2cm}} \Omega$$

$$I_{9mA} = \frac{V_{100\Omega}}{R_{100\Omega}} = \underline{\hspace{2cm}} \text{ mA}$$

$I_{9mA}$  is the characterized current for the 20mA range of the Model 263. It is used to calibrate the 10mA range of the Model 238. Using a pencil, record the calculated value of  $I_{9mA}$  in Entry 5 of Table 2-3.

36. Place the Model 263 in standby.

#### NOTE

To store calibration constants in nonvolatile memory, place the CAL LOCK switch to the unlocked "in" position (see paragraph 2.5). With the switch in the locked "out" position, calibration will be temporary. That is, the new calibration constants will be lost when the instrument is turned off.



Table 2-3 Model 263 I-Source Characterization

Entry	263 I-Source		Characterized I-Source Value	I-Source Value Limits*
	Range	Programmed Value		
1	2 $\mu$ A	0.9000 $\mu$ A	$I_{0.9\mu A} = \underline{\hspace{2cm}}$	0.9 $\mu$ A $\pm$ 450pA
2	20 $\mu$ A	9.000 $\mu$ A	$I_{9\mu A} = \underline{\hspace{2cm}}$	9 $\mu$ A $\pm$ 4.3nA
3	200 $\mu$ A	90.000 $\mu$ A	$I_{90\mu A} = \underline{\hspace{2cm}}$	90 $\mu$ A $\pm$ 45nA
4	2mA	0.9000mA	$I_{0.9mA} = \underline{\hspace{2cm}}$	0.9mA $\pm$ 430nA
5	20mA	9.000mA	$I_{9mA} = \underline{\hspace{2cm}}$	9mA $\pm$ 5.4 $\mu$ A

\*The characterized I-source values should be within the listed limits. These limits are based on 90-day specifications of the Models 263 and 193A. A characterized value that does not fall within these limits indicates a calculation error, or that the Model 263 and/or Model 193A is out of specification.

## 2.6.2 Voltage Calibration

For voltage calibration, connect the Model 193A DMM to the Model 238 via the Model 8006 test fixture as shown in Figure 2-3. Jumper A is initially installed to short the output of the Model 238 and the input of the Model 193A.

### WARNING

The following procedure uses hazardous voltages (100V) that could cause injury or death. Exercise extreme caution when encountering these lethal voltage levels. Make sure to connect the Model 8006 interlock circuit to the Model 238

Perform the following steps to calibrate the voltage source and measure ranges:

1. Set the Model 193A DMM to DC volts and autorange.
2. With the short (Jumper A) installed, zero the Model 193A by enabling zero.
3. Place the Model 238 in operate. The calibration mode cannot be entered with the Model 238 in standby.
4. Over the IEEE-488 bus, send the following command to enter the calibration mode:

C0X

Note: All other calibration commands (C1 through C59) will be ignored unless the C0 command is first sent over the bus.

5. With the short still installed, send the following command over the bus to perform common mode calibration:

C1X

Note: Common mode calibration takes approximately 30 seconds to complete.

6. Remove the short (Jumper A) and send the following command to source +0V on the 1.5V range:

C2X

7. From the display of the Model 193A, record the voltage reading ( $V_{MSR}$ ):

$V_{MSR} = \underline{\hspace{2cm}}$

8. Send the measured voltage reading ( $V_{MSR}$ ) over the bus with the C3 command as follows to calibrate off-set for the +1.5V source and measurement range:

C3, $V_{MSR}X$

For example, if the reading on the Model 193A is +0.00036V, send C3,.00036X or C3,36E-5X over the bus.

9. Send the following command to source +1.4V on the 1.5V range:

C4X

10. From the display of the Model 193A, record the voltage reading ( $V_{MSR}$ ):

$V_{MSR} = \underline{\hspace{2cm}}$

11. Send the measured voltage reading ( $V_{MSR}$ ) over the bus with the C5 command as follows to calibrate gain for the +1.5V source and measurement range:

C5, $V_{MSR}X$

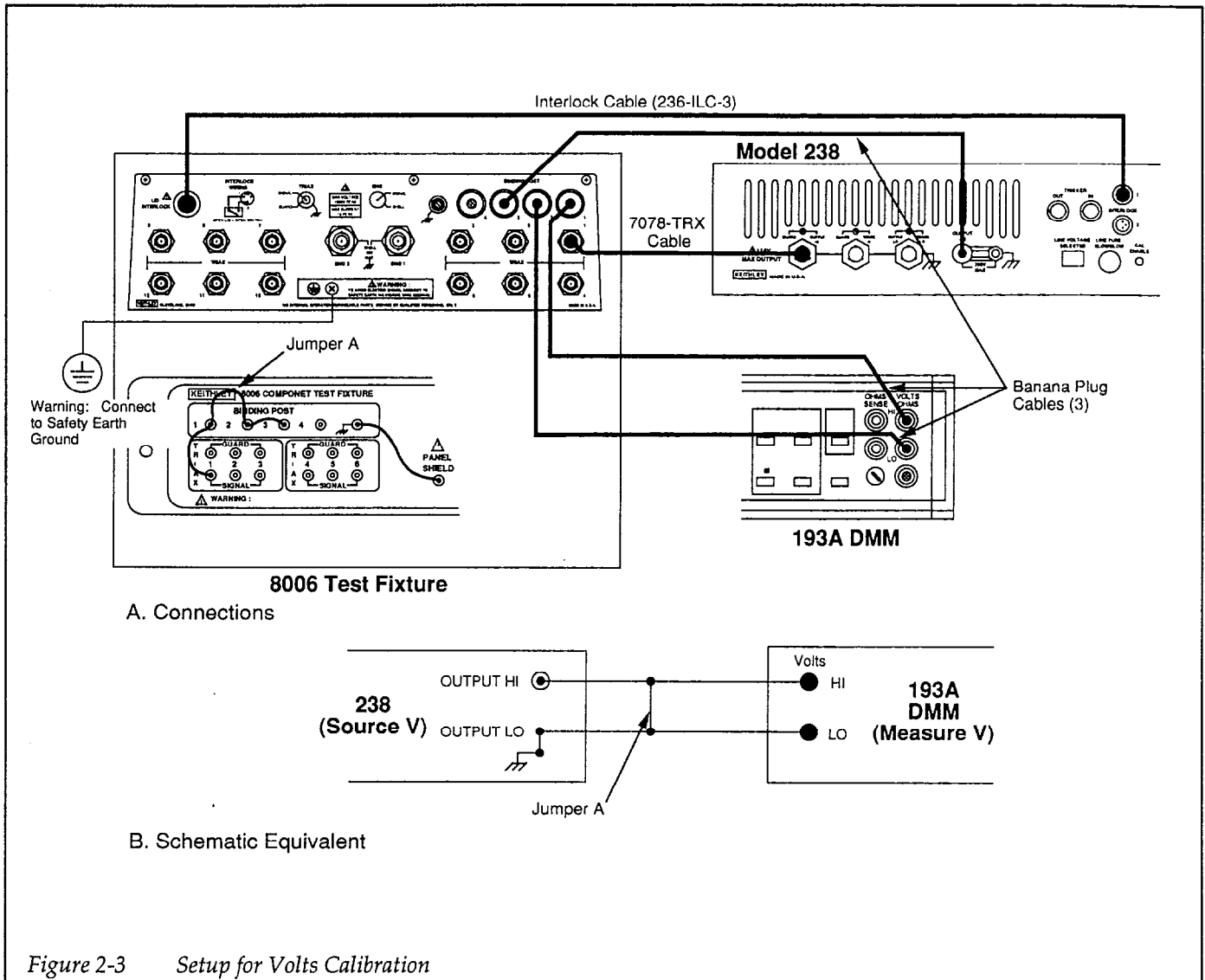

Figure 2-3 Setup for Volts Calibration

12. Send the following command to source -0V on the 1.5V range:  
C6X
13. From the display of the Model 193A, record the voltage reading ( $V_{MSR}$ ):  
 $V_{MSR} = \underline{\hspace{2cm}}$
14. Send the measured voltage reading ( $V_{MSR}$ ) over the bus with the C7 command as follows to calibrate offset for the -1.5V source and measurement range:  
C7, $V_{MSR}X$
15. Send the following command to source -1V on the 1.5V range:  
C8X
16. From the display of the Model 193A, record the voltage reading ( $V_{MSR}$ ):  
 $V_{MSR} = \underline{\hspace{2cm}}$
17. Send the measured voltage reading ( $V_{MSR}$ ) over the bus with the C9 command as follows to calibrate gain for the -1.5V source and measurement range:  
C9, $V_{MSR}X$
18. Send the following command to source +0V on the 15V range:  
C10X
19. From the display of the Model 193A, record the voltage reading ( $V_{MSR}$ ):  
 $V_{MSR} = \underline{\hspace{2cm}}$



20. Send the measured voltage reading ( $V_{MSR}$ ) over the bus with the C11 command as follows to calibrate offset for the +15V source and measurement range:  
C11, $V_{MSR}X$
21. Send the following command to source +14V on the 15V range:  
C12X
22. From the display of the Model 193A, record the voltage reading ( $V_{MSR}$ ):  
 $V_{MSR} = \underline{\hspace{2cm}}$
23. Send the measured voltage reading ( $V_{MSR}$ ) over the bus with the C13 command as follows to calibrate gain for the +15V source and measurement range:  
C13, $V_{MSR}X$
24. Send the following command to source -0V on the 15V range:  
C14X
25. From the display of the Model 193A, record the voltage reading ( $V_{MSR}$ ):  
 $V_{MSR} = \underline{\hspace{2cm}}$
26. Send the measured voltage reading ( $V_{MSR}$ ) over the bus with the C15 command as follows to calibrate offset for the -15V source and measurement range:  
C15, $V_{MSR}X$
27. Send the following command to source -14V on the 15V range:  
C16X
28. From the display of the Model 193A, record the voltage reading ( $V_{MSR}$ ):  
 $V_{MSR} = \underline{\hspace{2cm}}$
29. Send the measured voltage reading ( $V_{MSR}$ ) over the bus with the C17 command as follows to calibrate gain for the -15V source and measurement range:  
C17, $V_{MSR}X$
30. Send the following command to source +0V on the 110V range:  
C18X
31. From the display of the Model 193A, record the voltage reading ( $V_{MSR}$ ):  
 $V_{MSR} = \underline{\hspace{2cm}}$
32. Send the measured voltage reading ( $V_{MSR}$ ) over the bus with the C19 command as follows to calibrate offset for the +110V source and measurement range:  
C19X, $V_{MSR}X$
33. Send the following command to source +100V on the 110V range:  
C20X
34. From the display of the Model 193A, record the voltage reading ( $V_{MSR}$ ):  
 $V_{MSR} = \underline{\hspace{2cm}}$
35. Send the measured voltage reading ( $V_{MSR}$ ) over the bus with the C21 command as follows to calibrate gain for the +110V source and measurement range:  
C21, $V_{MSR}X$
36. Send the following command to source -0V on the 110V range:  
C22X
37. From the display of the Model 193A, record the voltage reading ( $V_{MSR}$ ):  
 $V_{MSR} = \underline{\hspace{2cm}}$
38. Send the measured voltage reading ( $V_{MSR}$ ) over the bus with the C23 command as follows to calibrate offset for the -110V source and measurement range:  
C23, $V_{MSR}X$
39. Send the following command to source -100V on the 110V range:  
C24X
40. From the display of the Model 193A, record the voltage reading ( $V_{MSR}$ ):  
 $V_{MSR} = \underline{\hspace{2cm}}$
41. Send the measured voltage reading ( $V_{MSR}$ ) over the bus with the C25 command as follows to calibrate gain for the -110V source and measurement range:  
C25, $V_{MSR}X$
42. Send the following command over the bus to exit calibration:  
Note: Check that the CAL LOCK switch is in the desired position; "in" for permanent calibration, or "out" for temporary calibration.  
C59X
- If the switch is in the "out" position, the message "TEMPORARY CAL" will be briefly displayed to indicate that newly entered cal constants will be lost when the Model 238 is turned off. Permanent calibration can still be done by setting the calibration switch to the "in" position, and sending C0X and C59X over the bus in that order.  
After sending the C59X command, the Model 238 will go into standby.





### 2.6.3 100mA and 1A Ranges Calibration

To calibrate the 100mA and 1A ranges, connect the circuit shown in Figure 2-4.

#### 100mA Range Calibration

Perform the following steps to calibrate the 100mA source and measure range:

1. Set the Model 193A to the 200µA (DC) range.
2. Place the Model 238 in operate. The calibration mode cannot be entered with the Model 238 in standby.
3. Over the IEEE-488 bus, send the following command to enter the calibration mode:

C0X

Note: All other calibration commands (C1 through C59) will be ignored unless the C0 command is first sent over the bus.

4. Send the following command to source +0mA on the 100mA range:

C34X

5. Set the Model 343A to output 0V and place the Model 2500E on the 100µA range.
6. From the display of the Model 193A, record the off-set current ( $I_{+0mA}$ ):

$I_{+0mA} = \underline{\hspace{2cm}}$

7. Send the current reading ( $I_{+0mA}$ ) over the bus with the C35 command as follows to calibrate offset for the 100mA range:

C35, $I_{+0mA}X$

8. Send the following command to source +90mA:

C36X

9. Set the calibration source to output -90mA on the 100mA range and, from the display of the Model 193A, record the current reading ( $I_{193A}$ ):

$I_{193A} = \underline{\hspace{2cm}}$

10. Calculate the actual current ( $I_{+90mA}$ ) using the following calculation:

$I_{+90mA} = 90mA + I_{193A} = \underline{\hspace{2cm}} mA$

11. Send the calculated current reading ( $I_{+90mA}$ ) over the bus with the C37 command as follows to calibrate

gain for the +100mA source and measurement range:

C37, $I_{+90mA}X$

12. Send the following command to source -0mA on the 100mA range:

C38X

13. Set the Model 343A to 0V and place the Model 2500E on the 100µA range.

14. From the display of the Model 193A, record the off-set current ( $I_{-0mA}$ ):

$I_{-0mA} = \underline{\hspace{2cm}}$

15. Send the current reading ( $I_{-0mA}$ ) over the bus with the C39 command as follows to calibrate gain for the -100mA source and measurement range:

C39, $I_{-0mA}X$

16. Send the following command to source -90mA:

C40X

17. Set the calibration source to +90mA on the 100mA range.

18. From the display of the Model 193A, record the current reading ( $I_{-193A}$ ):

$I_{-193A} = \underline{\hspace{2cm}}$

19. Calculate the actual current using the following calculation:

$I_{-90mA} = -90mA + I_{-193A} = \underline{\hspace{2cm}} mA$

20. Send the calculated current reading ( $I_{-90mA}$ ) over the bus with the C41 command as follows to calibrate gain for the -100mA source and measure range:

C41, $I_{-90mA}X$

21. Send the following command over the bus to exit calibration:

Note: Check that the CAL LOCK switch is in the desired position; "in" for permanent calibration, or "out" for temporary calibration.

C59X

If the switch is in the "out" position, the message "TEMPORARY CAL" will be briefly displayed to indicate that newly entered cal constants will be lost when the Model 238 is turned off. Permanent calibration can still be done by setting the calibration switch to the "in" position, and sending C0X and C59X over the bus in that order.

After sending the C59X command, the Model 238 will go into standby.



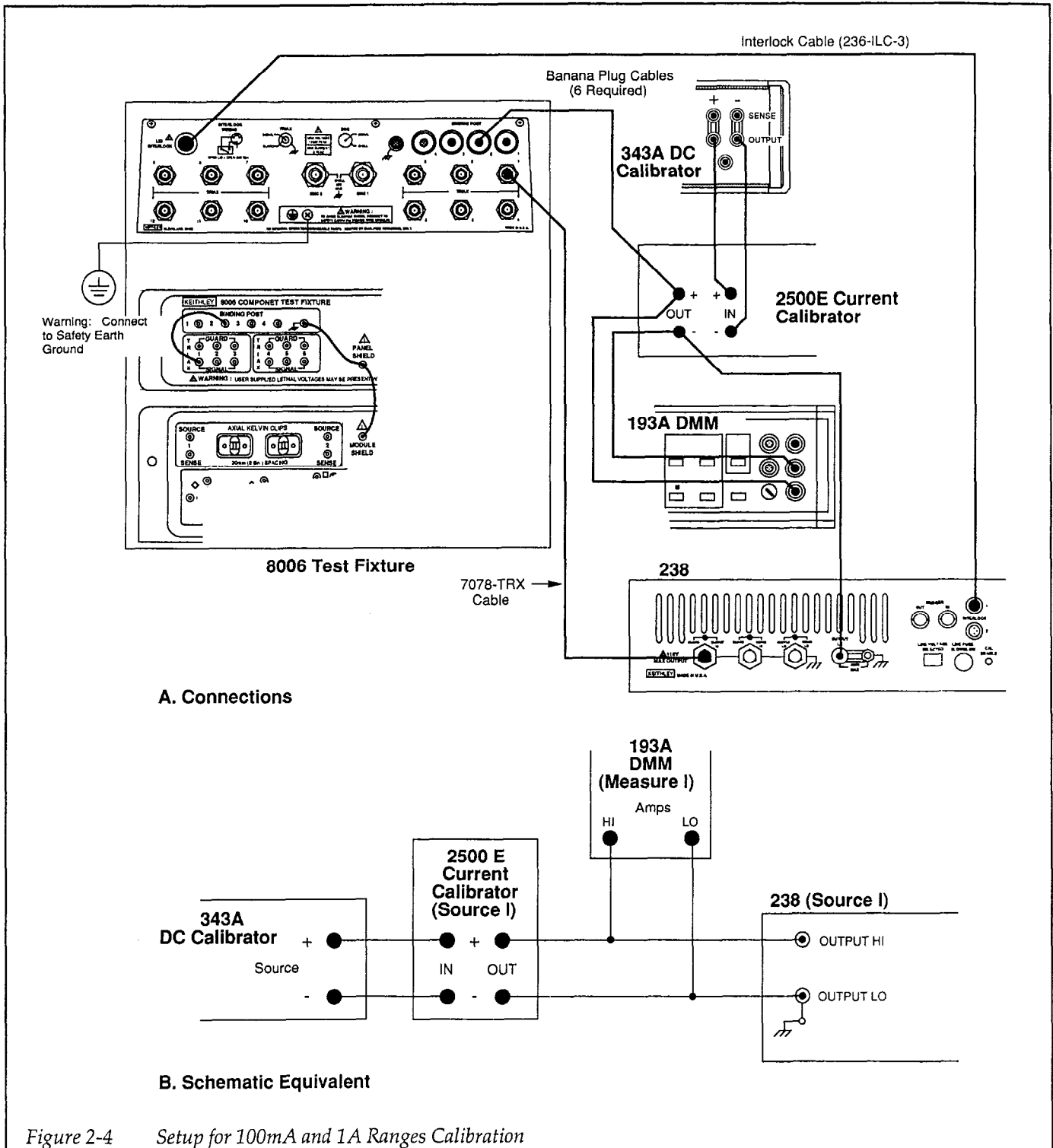

Figure 2-4 Setup for 100mA and 1A Ranges Calibration



### 1A Range Calibration

Perform the following steps to calibrate the 1A source and measure range:

1. Set the Model 193A to the 2mA (DC) range.
2. Place the Model 238 in operate. The calibration mode cannot be entered with the Model 238 in standby.
3. Over the IEEE-488 bus, send the following command to enter the calibration mode:

C0X

Note: All other calibration commands (C1 through C59) will be ignored unless the C0 command is first sent over the bus.

4. Send the following command to source +0mA on the 1A range:

C26X

5. Set the Model 343A to 0V and place the Model 2500E on the 100 $\mu$ A range.
6. From the display of the Model 193A, record the offset current ( $I_{+0A}$ ):

$I_{+0A} = \underline{\hspace{2cm}}$

7. Send the current reading ( $I_{+0A}$ ) over the bus with the C27 command as follows to calibrate offset for the +1A source and measure range:

C27, $I_{+0A}X$

8. Send the following command to source +0.9A:

C28X

9. Set the calibration source to -0.9A on the 1A range
10. From the display of the Model 193A, record the current ( $I_{193A}$ ):

$I_{193A} = \underline{\hspace{2cm}}$

11. Calculate the actual current ( $I_{+0.9A}$ ) using the following calculation:

$I_{+0.9A} = 0.9A + I_{193A} = \underline{\hspace{2cm}} A$

12. Send the calculated current reading ( $I_{+0.9A}$ ) over the bus with the C29 command as follows to calibrate gain for the +1A source and measure range:

C29, $I_{+0.9A}X$

13. Send the following command to source -0A on the 1A range:

C30X

14. Set the Model 343A to 0V and place the Model 2500E on the 100 $\mu$ A range.
15. From the display of the Model 193A, record the offset current ( $I_{-0A}$ ):

$I_{-0A} = \underline{\hspace{2cm}}$

16. Send the current reading ( $I_{-0A}$ ) over the bus with the C31 command as follows to calibrate offset for the -1A source and measure range:

C31, $I_{-0A}X$

17. Send the following command to source -0.9A:

C32X

18. Set the calibration source to +0.9A on the 1A range.
19. From the display of the Model 193A, record the current ( $I_{-193A}$ ):

$I_{-193A} = \underline{\hspace{2cm}}$

20. Calculate the actual current ( $I_{-0.9A}$ ) using the following calculation:

$I_{-0.9A} = -0.9A + I_{-193A} = \underline{\hspace{2cm}}$

21. Send the calculated reading ( $I_{-0.9A}$ ) over the bus with the C33 command as follows to calibrate gain for the -1A source and measure range:

C33, $I_{-0.9A}X$

22. Send the following command over the bus to exit calibration:

Note: Check that the CAL LOCK switch is in the desired position; "in" for permanent calibration, or "out" for temporary calibration.

C59X

If the switch is in the "out" position, the message "TEMPORARY CAL" will be briefly displayed to indicate that newly entered cal constants will be lost when the Model 238 is turned off. Permanent calibration can still be done by setting the calibration switch to the "in" position, and sending C0X and C59X over the bus in that order.

After sending the C59X command, the Model 238 will go into standby.

## 2.6.4 Low Current Ranges Calibration (1nA – 10mA)

Connect the characterized Model 263 calibrator to the Model 238 as shown in Figure 2-5. The characterized I-source values ( $I_{0.9\mu A}$ ,  $I_{9\mu A}$ ,  $I_{90\mu A}$ ,  $I_{0.9mA}$  and  $I_{9mA}$ ) of the Model 263 that are used to calibrate the 1 $\mu A$  through 10mA ranges were determined in the equipment characterization procedure (paragraph 2.6.1) and recorded in Table 2-3.

Perform the following steps to calibrate the 1nA through 10mA measurement ranges:

### NOTE

If controlling the Model 263 from the front panel, always select the lowest possible current range. Over the bus, AUTO range can be used.

1. In standby, set the Model 263 to 0.9nA and enable Guard.
2. Place the Model 238 in Operate. The calibration mode cannot be entered with the Model 238 in standby.
3. Over the IEEE-488 bus, send the following command to enter the calibration mode:

C0X

Note: All other calibration commands (C1 through C59) will be ignored unless the C0 command is first sent over the bus.

4. Send the following command over the IEEE-488 bus to calibrate offset for the 1nA measurement range:

C42X

Note: Calibration takes approximately 20 seconds to complete.

5. Place the Model 263 in operate to source 0.9nA to the Model 238.
6. Send the following command over the bus to calibrate gain for the 1nA measurement range:

C43,0.9E-9X

Note: Calibration takes approximately 20 seconds to complete.

7. Place the Model 263 in standby and set it to 9nA.
8. Send the following command over the bus to calibrate offset for the 10nA measurement range:

C44X

Note: Calibration takes approximately 10 seconds to complete.

9. Place the Model 263 in operate to source 9nA to the Model 238.
10. Send the following command over the bus to calibrate gain for the 10nA measurement range:

C45,9E-9X

Note: Calibration takes approximately 10 seconds to complete.

11. Place the Model 263 in standby and set it to 90nA.
12. Send the following command over the bus to calibrate offset of the 100nA measurement range:

C46X

Note: Calibration takes approximately four seconds to complete.

13. Place the Model 263 in operate to source 90nA to the Model 238.

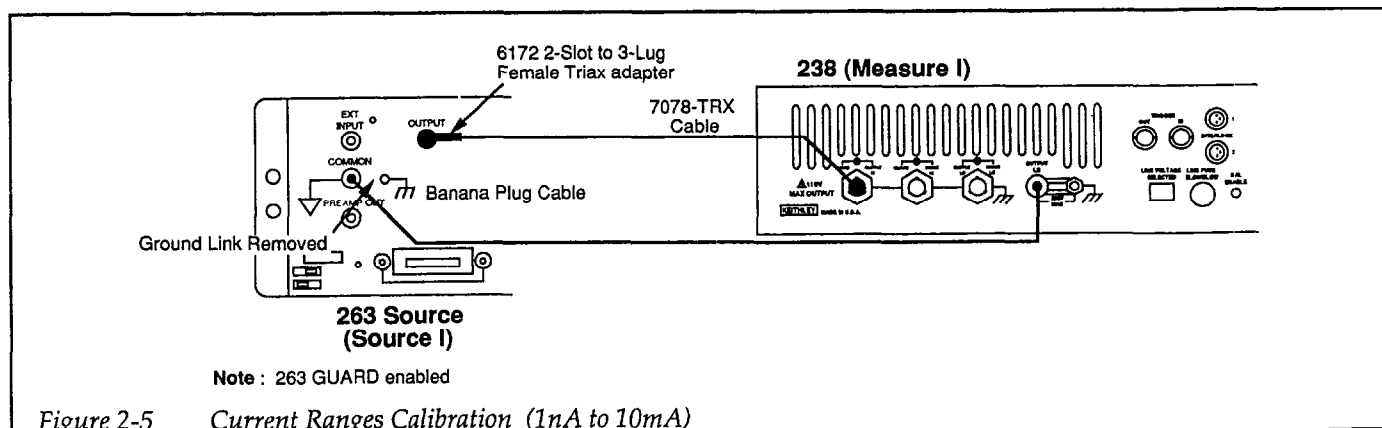



14. Send the following command over the bus to calibrate gain for the 100nA measurement range:

C47,90E-9X

Note: Calibration takes approximately four seconds to complete.

15. Place the Model 263 in standby and set it to 0.9 $\mu$ A.  
16. Send the following command over the bus to calibrate offset for the 1 $\mu$ A measurement range:

C48X

17. Place the Model 263 in operate.  
18. Send the value for  $I_{0.9\mu A}$  (from Table 2-3) over the bus with the C49 command as follows to calibrate gain for the 1 $\mu$ A measurement range:

C49, $I_{0.9\mu A}X$

For example, if  $I_{0.9\mu A} = 0.90036\mu A$ , send C49,0.90036E-6X.

19. Place the Model 263 in standby and set it to 9 $\mu$ A.  
20. Send the following command over the bus to calibrate offset for the 10 $\mu$ A measurement range:

C50X

21. Place the Model 263 in operate.  
22. Send the value for  $I_{9\mu A}$  (from Table 2-3) over the bus with the C51 command as follows to calibrate gain for the 10 $\mu$ A measurement range:

C51, $I_{9\mu A}X$

23. Place the Model 263 in standby and set it to 90 $\mu$ A.  
24. Send the following command over the bus to calibrate offset for the 100 $\mu$ A measurement range:

C52X

25. Place the Model 263 in operate.  
26. Send the value for  $I_{90\mu A}$  (from Table 2-3) over the bus with the C53 command as follows to calibrate gain for the 100 $\mu$ A measurement range:

C53, $I_{90\mu A}X$

27. Place the Model 263 in standby and set it to 0.9mA.  
28. Send the following command over the bus to calibrate offset for the 1mA measurement range:

C54X

29. Place the Model 263 in operate.  
30. Send the value for  $I_{0.9mA}$  (from Table 2-3) over the bus with the C55 command as follows to calibrate gain of the 1mA measurement range:

C55, $I_{0.9mA}X$

31. Place the Model 263 in standby and set it to 9mA.  
32. Send the following command over the bus to calibrate offset for the 10mA measurement range:

C56X

33. Place the Model 263 in operate.  
34. Send the value for  $I_{9mA}$  (from Table 2-3) over the bus with the C57 command as follows to calibrate gain for the 10mA measurement range:

C57, $I_{9mA}X$

35. Place the Model 263 in standby and set it to 0mV.  
36. Place the Model 263 in operate.  
37. Send the following command over the bus to calibrate the 1nA through 10mA source ranges:

C58X

Note: Calibration of the low current source ranges takes approximately four minutes to complete.

Note: Check that the CAL LOCK switch is in the desired position; "in" for permanent calibration, or "out" for temporary calibration.

38. Send the following command over the bus to exit calibration and store the cal constants:

C59X

If the switch is in the "out" position, the message "TEMPORARY CAL" will be briefly displayed to indicate that newly entered cal constants will be lost when the Model 238 is turned off. Permanent calibration can still be done by setting the calibration switch to the "in" position, and sending C0X and C59X over the bus in that order.

After sending the C59X command, the Model 238 will go into standby.

39. Place the 263 into standby.



## 2.7 CALIBRATION ERRORS

Calibration errors and subsequent error messages that could occur during calibration are explained in Table 2-4. It is important to realize that if any of these errors (except IN CAL) occur, calibration is compromised. Even though some errors will cause default cal constants to be used, they do not guarantee specified accuracy. When a calibration error occurs, find and fix the problem and repeat calibration.

Since calibration error messages are briefly displayed by the Model 238, they can be easily overlooked. For this reason it is strongly recommended that calibration errors be detected and displayed by the calibration program. The

following steps provide the general procedure required to detect calibration errors over the IEEE-488 bus:

1. Program the Model 238 to generate an SRQ on an error by sending the M32 command over the bus.
2. When an SRQ occurs (error), send the U1 command and then address the Model 238 to talk.
3. Display the character string (U1 Error Status Word) from the Model 238 on the computer CRT and refer to Figure 2-6 to determine the error type.
4. After displaying the U1 error status word, send the U7 command and address the Model 238 to talk.
5. Display the character string (U7 Calibration Status Word) on the computer CRT and refer to Figure 2-7 to determine which calibration step failed. This status word also provides the status of the CAL LOCK switch.

**Table 2-4 Calibration Error Messages**

Message	Explanation
IN CAL	Tried to set the instrument to a state that is illegal while in the calibration mode. Legal commands include; C (calibration), N (operate/standby), O (output sense) and U (status). From the front panel, only operate/standby and output sense can be set. All illegal commands and operations are ignored.
IN STBY	The Model 238 is in standby. The calibration command sent over the bus will not be executed. (See Note).
CAL COMPLI	Compliance has occurred during calibration. Check test setup connections and instrument settings.
CAL MODE ERR	Common mode calibration error. Output of Model 238 is not shorted or unit is defective. The cal constant from the previous calibration will be used.
CAL VALUE ERR	Invalid calibration value sent to the Model 238. This calibration step is ignored (not attempted). Calibration constant from previous calibration will be used.
CAL ADC ZERO	Measure offset calibration error. Calibration is attempted using a value that is not within acceptable limits. The transmitted value is ignored and a default cal constant value is used instead. Possible problems include; incorrect cal constant value, defective calibration equipment (or connections), or defective Model 238.
CAL ADC GAIN	Measure gain calibration error. Calibration is attempted using a value that is not within acceptable limits. The transmitted value is ignored and a default cal constant value is used instead. Possible problems include; incorrect cal constant value, defective calibration equipment (or connections), or defective Model 238.
CAL SRC ZERO	Source offset calibration error. Calibration is attempted using a value that is not within acceptable limits. The transmitted value is ignored and a default cal constant value is used instead. Possible problems include; incorrect cal constant value, defective calibration equipment (or connections), or defective Model 238.
CAL SRC GAIN	Source gain calibration error. Calibration is attempted using a value that is not within acceptable limits. The transmitted value is ignored and a default cal constant value is used instead. Possible problems include; incorrect cal constant value, defective calibration equipment (or connections), or defective Model 238.

Note: During the execution of a calibration step in which the Model 238 takes a measurement conversion, it is possible the instrument can transition from OPERATE to STANDBY. This can occur because it was specifically programmed to do so, or because the test fixture safety interlock was opened.

In this event, the OPERATE and STANDBY transition is detected and the measurement conversion used to compute the calibration constant is ignored. The front panel message "IN STBY" is displayed when this occurs.

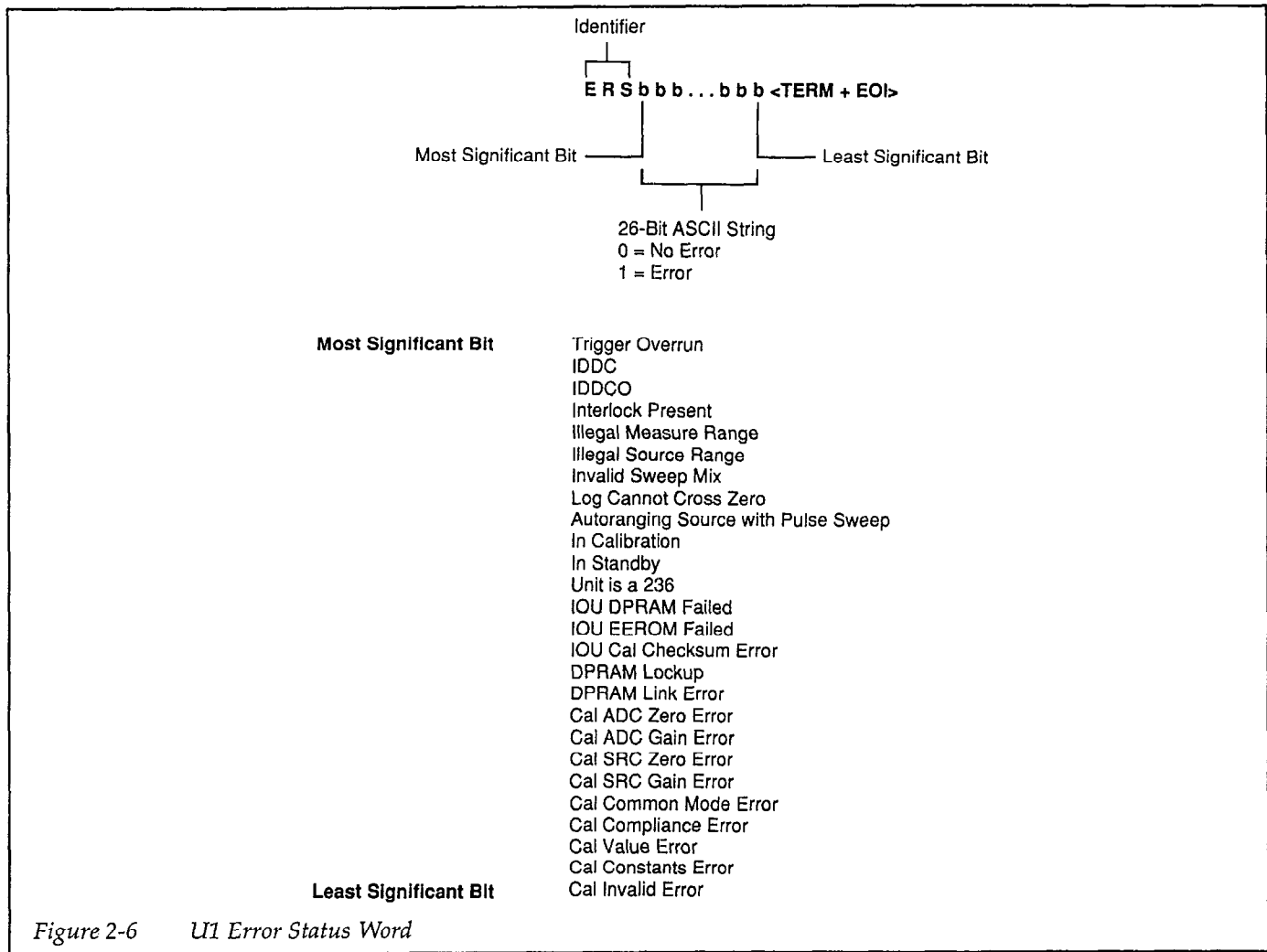

Figure 2-6 U1 Error Status Word

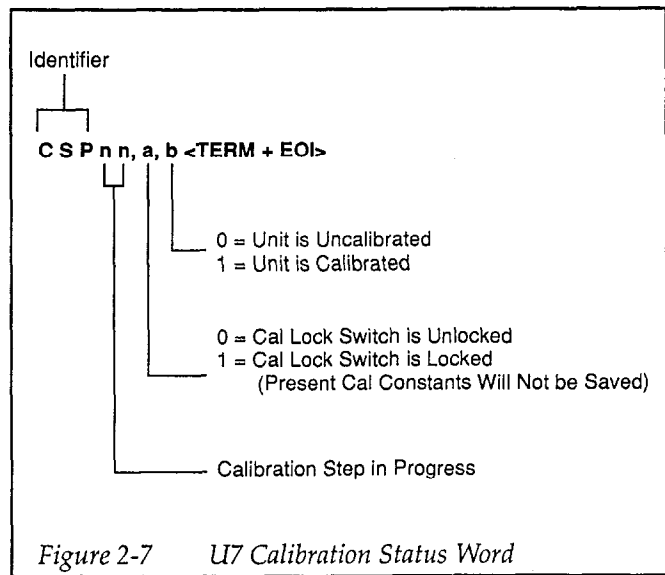

Figure 2-7 U7 Calibration Status Word

## 2.8 CALIBRATION PROGRAM

The following program can be used to calibrate the Model 238. Configure the recommended equipment and software per manufacturers instructions and type in the program.

### NOTE

The program does not calibrate the 1A range since the equipment used to calibrate that range is not programmable and thus, cannot be controlled over the IEEE-488 bus.



'Rev. B 10/11/90

```
*****
'*                                     Model 238 Calibration Program           *
'* NOTE: Program calibrates voltage and InA-10mA current ranges only.         *
'* Equipment Required: Model 193A DMM, Model 263 Calibrator                     *
'* 193A address = 10; 238 address = 16; 263 address = 8                         *
'* Computer: IBM PC, AT or compatible                                           *
'* IEEE-488 interface card: IOtech, CEC, or National PC-II or IIA              *
'* Operating system: PC-DOS or MS-DOS, version 3.0 or later                    *
'* Programming language: Microsoft QuickBASIC version 4.0 or later             *
'* IEEE-488 bus driver: IOtech Driver488, version 2.3 or later                 *
*****
```

CLS

OPTION BASE 1

DIM char(5), char\$(5), Ical(8), msg\$(3) ' Dimension arrays.

DIM Err\$(9)

FOR I = 1 TO 5: READ char\$(I): NEXT I ' Read prompt strings.

FOR I = 1 TO 8: READ Ical(I): NEXT I ' Read cal currents.

FOR I = 1 TO 3: READ msg\$(I): NEXT I ' Read procedure messages.

FOR I = 1 TO 9: READ Err\$(I): NEXT I ' Read error messages.

Dly = 3 ' Measurement delay (seconds).

\*\*\*\*\* INITIALIZE IEEE-488 INTERFACE \*\*\*\*\*

OPEN "\DEV\IEEEOUT" FOR OUTPUT AS #1 ' Open IEEE-488 output path.

OPEN "\DEV\IEEEIN" FOR INPUT AS #2 ' Open IEEE-488 input path.

Start: IOCTL #1, "BREAK" ' Reset interface.

PRINT #1, "RESET" ' Warm start interface.

PRINT #1, "REMOTE" ' Assert remote enable.

PRINT #1, "CLEAR" ' Send device clear.

PRINT #1, "TIME OUT 30" ' 30 second bus time out.

PRINT #1, "LOL" ' Enable Local Lockout

CLS ' Clear screen.

LOCATE 12, 23

PRINT " Model 238 Calibration Program"

LOCATE 21, 12

PRINT "NOTE: This program does NOT calibrate 100mA and 1A ranges."

LOCATE 22, 12

PRINT "Refer to Service Manual for complete information."

LOCATE 14, 10

GOSUB KeyCheck ' Check for operator signal.

\*\*\*\*\* SELECT FUNCTION(S) TO CALIBRATE \*\*\*\*\*

SelCal:

CLS

GOSUB TypeCheck

E = 0: C1 = 0 ' Clear error counter.

PRINT "Select function to calibrate:"

PRINT

FOR I = 1 TO 3 ' Loop for all 3 selections.

PRINT " "; I; "- "; msg\$(I); " calibration"

NEXT I

PRINT



```

InCal: INPUT "Select calibration function (1-3)"; cal
IF cal < 1 OR cal > 3 THEN BEEP: GOTO InCal
PRINT
'
'***** INITIALIZE 238 *****
PRINT #1, "OUTPUT 16;M32,X"      ' 238 SRQ on error.
PRINT #1, "OUTPUT 16;B0,,X"    ' Zero bias output level for safety.
PRINT #1, "OUTPUT 16;OOX"      ' Local sensing.
PRINT #1, "OUTPUT 16;KOYOX"    ' Enable EOI, hold-off, terminator.
'
'***** CHECK CAL LOCK SWITCH STATUS *****
PRINT #1, "OUTPUT 16;U7X"      ' Request calibration status word.
PRINT #1, "ENTER 16"          ' Address 238 to talk.
LINE INPUT #2, ST$            ' Input cal status word.
IF MID$(ST$, 7, 1) = "1" THEN ' Check cal lock switch status.
    BEEP
    PRINT "Model 238 Cal Lock switch is in locked position."
    PRINT "Calibration will be only temporary."
    PRINT
    C1 = 1
    GOSUB KeyCheck
END IF
'
'***** ENABLE BUS SRQ ERROR TRAPPING *****
'
ON PEN GOSUB ErrCheck          ' Point to error routine.
PEN ON                          ' Enable error detection.
PRINT #1, "ARM SRQ"           ' Enable SRQ.
'
'***** MAIN PROGRAM LOOP *****
'
ON cal GOSUB CalVolt, CalLow
IF cal = 3 THEN
    GOSUB CalVolt
    GOSUB CalLow
END IF
PRINT : BEEP
PRINT #1, "CLEAR"              ' Send DCL.
PRINT msg$(cal); " calibration procedure completed."
PRINT E; "error(s) detected during calibration."
PRINT
IF C1 = 1 THEN PRINT "NOTE: Calibration is temporary."
PRINT
INPUT "Rerun calibration program (y/n)"; IN$
IN$ = LEFT$(IN$, 1)
IF IN$ = "y" OR IN$ = "Y" THEN GOTO SelCal
PRINT #1, "LOCAL"              ' Restore local operation.
CLOSE 1: CLOSE 2               ' Close I/O files.
END                             ' End of program.
'
'*****
'*          VOLTAGE FUNCTION CALIBRATION ROUTINES          *
'*****
'

```

```

CalVolt:
CLS
PRINT "Voltage Calibration Procedure."
PRINT "See Service Manual for details on test connections."
PRINT
PRINT "Short 238 output and 193A input."
GOSUB KeyCheck
PRINT #1, "OUTPUT 10;FOROS3G1X"      ' 193A DCV, 6-1/2 digits, auto range.
PRINT #1, "OUTPUT 16;N1X"           ' Put 238 in operate.
PRINT #1, "OUTPUT 16;COX"           ' Put 238 in cal mode.
PRINT "Performing common mode adjustment."
PRINT "Please wait approximately 30 seconds for completion."
PRINT
PRINT #1, "OUTPUT 16;C1X"            ' Calibrate 238 common mode.
PRINT #1, "OUTPUT 10;Z1X"            ' Zero 193A.
BEEP
PRINT #1, "OUTPUT 16;C59X"           ' Remove 238 from cal mode.
PRINT #1, "OUTPUT 16;NOX"           ' Put 238 in standby.
PRINT "Remove short from 238 output and 193A input."
PRINT "Make sure 238 output is properly connected to 193A input."
PRINT
BEEP
PRINT "WARNING: Hazardous voltage may be present on terminals."
PRINT
GOSUB KeyCheck
PRINT #1, "OUTPUT 16;N1X"            ' Put 238 in operate.
PRINT #1, "OUTPUT 16;COX"           ' Put 238 in cal mode.
PRINT "Performing voltage calibration."
PRINT "Press ESC to abort procedure and restart program."
FOR I = 2 TO 25                       ' Loop for all cal points.
IN$ = INKEY$: IF IN$ = CHR$(27) THEN PRINT #1, "CLEAR": GOTO SelCal
PRINT #1, "OUTPUT 16;C"; I; "X"      ' Send cal command to 238.
GOSUB Delay                           ' Wait for settling.
PRINT #1, "ENTER 10"                 ' Get reading from 193A.
INPUT #2, Vmsr                        ' Input 193A reading.
I = I + 1                              ' Increment C command value.
PRINT #1, "OUTPUT 16;C"; I; ", "; Vmsr; "X" ' Send cal value to 238.
NEXT I                                 ' Loop back for next cal point.
PRINT #1, "OUTPUT 16;C59X"           ' Exit calibration procedure.
PRINT #1, "OUTPUT 16;NOX"           ' Put 238 in standby.
PRINT #1, "OUTPUT 10;ZOR5X"         ' Disable 193A zero mode, 1000V range.
RETURN

```

```

' *****
' *                1nA - 10mA CURRENT RANGE CALIBRATION ROUTINES                *
' *****

```

```

CalLow:
CLS
PRINT "1nA - 10mA Current Range Calibration."
PRINT "Make sure 263 and 238 are properly connected."
PRINT "See Service Manual for complete details."
PRINT
GOSUB KeyCheck

```



```

PRINT #1, "OUTPUT 08;F1ROW1X"          ' 263 amps, auto range, guard on.
' INPUT 263 CHARACTERIZATION PARAMETERS
CharCheck:
INPUT "Enter 263 characterization parameters (y/n)"; IN$
IN$ = LEFT$(IN$, 1)
IF IN$ = "N" OR IN$ = "n" THEN GOTO NoChar
IF IN$ <> "y" AND IN$ <> "Y" THEN BEEP: GOTO CharCheck
PRINT
InChar: PRINT "Enter the following 263 characterization parameters."
PRINT "See Service Manual for 263 characterization procedure."
PRINT
FOR I = 1 TO 5                          ' Loop for all parameters
PRINT "Enter parameter for 263 "; char$(I); " "; ' Prompt for parameter.
INPUT char(I)                            ' Input parameter.
NEXT I                                    ' Loop back for next parameter.
NoChar:
FOR I = 1 TO 5
IF char(I) = 0 THEN
    BEEP
    PRINT "Improper characterization parameters are presently entered."
    GOTO InChar
END IF
NEXT I
PRINT
GOSUB KeyCheck
PRINT "Performing 1nA - 10mA current measurement calibration procedure."
PRINT "Press ESC to abort procedure and restart program."
PRINT #1, "OUTPUT 16;N1X"                ' Put 238 in operate.
PRINT #1, "OUTPUT 16;COX"                ' Put 238 in cal mode.
J = 1: K = 1                             ' Initialize array index counters.
FOR I = 42 TO 57                          ' Loop for all cal points.
IN$ = INKEY$: IF IN$ = CHR$(27) THEN PRINT #1, "CLEAR": GOTO SelCal
PRINT #1, "OUTPUT 08;V"; Ical(J); "X"    ' Program 263 current value.
GOSUB Delay                               ' Allow settling time.
PRINT #1, "OUTPUT 16;C"; I; "X"         ' Send cal offset command.
GOSUB Delay                               ' Settling time.
I = I + 1                                 ' Increment C command value.
PRINT #1, "OUTPUT 08;O1X"                ' Put 263 in operate.
GOSUB Delay                               ' Settling time.
IF I > 47 THEN                            ' Use characterized values for >100nA
    PRINT #1, "OUTPUT 16;C"; I; ", "; char(K); "X"
    K = K + 1                             ' Increment array counter.
ELSE PRINT #1, "OUTPUT 16;C"; I; ", "; Ical(J); "X"
END IF
GOSUB Delay                               ' Settling time.
J = J + 1                                 ' Increment array index.
PRINT #1, "OUTPUT 08;OOX"                ' Put 263 in standby.
NEXT I                                    ' Loop back for next cal point.
' 1nA - 10mA SOURCE CALIBRATION
PRINT #1, "OUTPUT 08;F2R1X"              ' 263 200mV range.
PRINT #1, "OUTPUT 08;VOX"                ' 263 0mV output.
PRINT #1, "OUTPUT 08;O1X"                ' Put 263 in operate.
GOSUB Delay
PRINT #1, "TIME OUT 240"                 ' Select 4 minute bus time out.

```

```

PRINT : BEEP
PRINT "Performing InA - 10mA source calibration."
PRINT "Please wait approximately 3-4 minutes for completion."
PRINT #1, "OUTPUT 16;C58X"          ' Cal 238 InA-10mA source.
PRINT #1, "OUTPUT 16;C59X"          ' Exit 238 cal mode.
PRINT #1, "OUTPUT 16;NOX"           ' Put 238 in standby.
PRINT #1, "OUTPUT 08;OOX"           ' Put 263 in standby.
PRINT #1, "TIME OUT 30"             ' Restore 30 sec. bus time out.
RETURN
'
KeyCheck:                            ' Check keyboard input routine.
PRINT "Press SPACE or ENTER key to continue (ESC to end program)."
```

```

PRINT
Lp1: IN$ = INKEY$: IF IN$ <> "" THEN GOTO Lp1
Lp3: IN$ = INKEY$: IF IN$ = "" THEN GOTO Lp3
IF IN$ = CHR$(27) THEN                ' Check for ESC.
    CLS
OutMsg: PRINT "Program terminated"
    PRINT #1, "CLEAR"                 ' Send DCL.
    PRINT #1, "ABORT"                 ' Send IFC.
    PRINT #1, "LOCAL"                 ' Restore local operation.
    CLOSE 1
    CLOSE 2
    END
END IF
IF IN$ <> CHR$(32) AND IN$ <> CHR$(13) THEN BEEP: GOTO Lp1
RETURN
'
Delay:                                ' Delay subroutine
t = TIMER
Lp2: IF (TIMER - t) < Dly THEN GOTO Lp2
RETURN
'
ErrCheck:                              ' Error check subroutine.
IF IOCTL$(2) <> "0" THEN RETURN       ' Driver ready for command?
PRINT #1, "SPOLL"                     ' Check for non-SRQ interrupt.
INPUT #2, SB
IF SB = 0 THEN RETURN
PRINT #1, "SPOLL 16"                   ' Serial poll 238.
INPUT #2, SB                           ' Input serial poll byte.
IF (SB AND 32) <> 0 THEN               ' Check for error.
    E = E + 1                          ' Increment error counter.
    BEEP
    PRINT #1, "OUTPUT 16;U1X"          ' Request error word.
    PRINT #1, "ENTER 16"
    INPUT #2, Err$                      ' Input error word.
    PRINT
    GOSUB CalStep
    PRINT "Model 238 ";
    GOSUB DispErr
    PRINT " Error on calibration step #"; ST; "."
    PRINT "See calibration error message list in Service Manual."
    PRINT
    GOSUB KeyCheck

```

```

        PRINT "Continuing..."
    END IF
    RETURN
    '
    DispErr:                                ' Display error subroutine.
    IF MID$(Err$, 7, 1) = "1" THEN PRINT "Interlock Present";
    IF MID$(Err$, 14, 1) = "1" THEN PRINT "In Standby";
    IF MID$(Err$, 13, 1) = "1" THEN PRINT "In Calibration";
    FOR L = 1 TO 9                            ' Check cal error messages.
    IF MID$(Err$, L + 20, 1) = "1" THEN PRINT Err$(L);
    NEXT L
    RETURN
    '
    CalStep:                                ' Determine cal step for cal error.
    PRINT #1, "OUTPUT 16;U7X"                ' Request cal status word.
    PRINT #1, "ENTER 16"                    ' Address 236 to talk.
    LINE INPUT #2, ST$                       ' Input cal status word.
    ST = VAL(MID$(ST$, 4, 2))                ' Convert step to variable.
    RETURN
    '
    TypeCheck:                               ' Make sure unit is a 238.
    PRINT #1, "OUTPUT 16;UOX"
    PRINT #1, "ENTER 16"
    INPUT #2, ST$
    IF LEFT$(ST$, 3) <> "238" THEN
        BEEP
        PRINT "Unit is not a Model 238."
        GOTO OutMsg
    END IF
    RETURN
    '
    ' Characterization prompt strings
    DATA "2uA range (approx. 0.9uA)"
    DATA "20uA range (approx. 9uA)"
    DATA "200uA range (approx. 90uA)"
    DATA "2mA range (approx. 0.9mA)"
    DATA "20mA range (approx. 9mA)"
    '
    ' Current calibration data
    DATA 0.9E-9,9E-9,90E-9,0.9E-6,9E-6,90E-6,0.9E-3,9E-3
    '
    ' Procedure message data strings
    DATA "Voltage"
    DATA "1nA to 10mA current ranges"
    DATA "Voltage and 1nA to 10mA current ranges"
    '
    ' Error message strings.
    DATA "Cal ADC Zero","Cal ADC Gain","Cal SRC Zero","Cal SRC Gain"
    DATA "Cal Common Mode","Cal Compliance","Cal Value"
    DATA "Cal Constants","Cal Invalid"

```

# SECTION 3

## Maintenance

### 3.1 INTRODUCTION

This section contains information necessary to maintain and troubleshoot the Model 238.

#### WARNING

Other than line fuse replacement and fan filter cleaning, the procedures included in this section are for use only by qualified service personnel. Do not perform these procedures unless qualified to do so. Troubleshooting steps may expose you to potentially lethal voltages that could result in injury or death if normal safety precautions are not observed.

### 3.2 LINE FUSE REPLACEMENT

A rear panel fuse located adjacent to the line voltage switch (see Figure 3-1) protects the power line input of the Source Measure Unit. If the fuse needs to be replaced (line voltage switch setting changed or suspected blown fuse), perform the following steps:

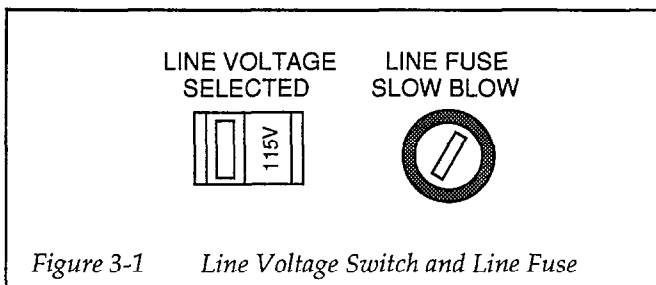

Figure 3-1 Line Voltage Switch and Line Fuse

#### WARNING

Make sure the Source Measure Unit is disconnected from the power line and other equipment before replacing the fuse.

1. With the power off, place the end of a flat-blade screwdriver into the slot in the rear panel LINE FUSE holder. Push in gently and rotate the fuse carrier one-quarter turn counterclockwise. Release pressure on the holder and its internal spring will push the fuse and carrier out of the holder.
2. Remove the fuse and replace it with the type recommended in Table 3-1.

Table 3-1 Line Fuse Selection

Line Voltage	Fuse Type	Keithley Part Number
195-250V	0.625A, 250V, 3AG, Slo Blo	FU-27
90-125V	1.25A, 250V, 3AG, Slo Blo	FU-28

#### CAUTION

Do not use a fuse with a higher current rating than specified, or instrument damage may occur. If the instrument repeatedly blows fuses, locate and correct the cause of the trouble before replacing the fuse. See paragraph 3.8 for troubleshooting information.

3. Install the new fuse and the fuse carrier into the holder by reversing the above procedure.

### 3.3 FAN FILTER CLEANING

The Model 238 has an internal cooling fan to vent heat out of the instrument case. The fan has a filter to keep dirt and dust from entering the instrument case. Contamination on pc boards could result in degraded performance. The fan filter must be cleaned periodically to maintain internal cleanliness and proper ventilation.



Perform the following steps to remove and clean the fan filter element:

1. Turn off the Model 238. The fan must be off in order to prevent dirt and dust from being ingested into the instrument case while removing the filter element.
2. Position the instrument such that you are facing the rear panel. The cooling fan is internally mounted to the right-hand end of the rear panel. The filter assembly is mounted to the rear panel in front of the fan intake vents.
3. Remove the two screws that secure the vented shroud of the filter assembly to the rear panel. The filter assembly will swing away from the rear panel allowing the filter element to be removed.
4. To clean the filter element, blow out the dust and dirt with pressurized air or nitrogen.
5. Reinstall the filter assembly onto the rear panel. The two hinges of the filter assembly shroud fit into the rear panel vents. Make sure the filter element covers all the rear panel intake vents.

### 3.4 BATTERY REPLACEMENT

When line power to the Model 238 is turned off, the lithium battery on the digital board provides backup power to the memory in which user programmed setup conditions and sweep data are stored. The battery has enough capacity to maintain data for one year of continuous power off, or two years if the Model 238 is on for 12 hours every day. The battery by itself has a shelf life of eight years. Although the Model 238 will operate without a battery, it will not retain any setup conditions or sweep data when turned off. The instrument will power up to the factory default conditions.

The battery may be replaced with any 2450 lithium coin cell. It can also be ordered from Keithley (part number BA-44).

Replacement of the lithium battery is normally a safe procedure as long as these safety precautions are followed.

#### WARNING

The precautions below must be followed to avoid possible personal injury.

1. Do not short the battery terminals together.
2. Do not incinerate or otherwise expose to excessive heat (>60°C).

3. Keep lithium batteries away from all liquids.
4. Do not recharge lithium batteries.
5. Observe proper polarity when inserting battery into holder.

Replace the battery as follows:

1. Turn off the power, disconnect the line cord, and remove all test leads.
2. After allowing at least three minutes for internal capacitors to discharge, remove the top cover (see paragraph 3.6).
3. The battery is on the digital board (see Figure 3-2 for location). Pry the battery out of its holder using a non-metallic tool.

#### WARNING

Do not use a metal tool to pry out the battery as you could short the terminals.

4. Install the new battery, taking care to observe proper polarity as stamped on the battery holder. The plus (+) terminal of the battery faces up.
5. Reinstall the top cover.

### 3.5 HANDLING AND CLEANING PRECAUTIONS

When troubleshooting or otherwise working inside the instrument, care should be taken not to indiscriminately touch PC board traces and open wires to avoid contaminating them with body oils or other foreign matter. Areas covered by a shield within the Model 238 have high impedance devices or sensitive circuitry where contamination could cause degraded performance.

The same general precautions apply when replacing parts in these areas. When unsoldering and soldering parts, be careful not to spread the flux around the board to adjacent areas.

1. Using a squeeze bottle, carefully apply clean, uncontaminated methanol to the area to be cleaned. Use sufficient solution to thoroughly wet the circuit board.
2. Using a small, clean brush, wipe the area thoroughly until it is free of flux or contaminants. In some cases, it may be helpful to tilt the board at an angle and brush contaminants away from the affected area, allowing contaminated residue and methanol to run off the board.



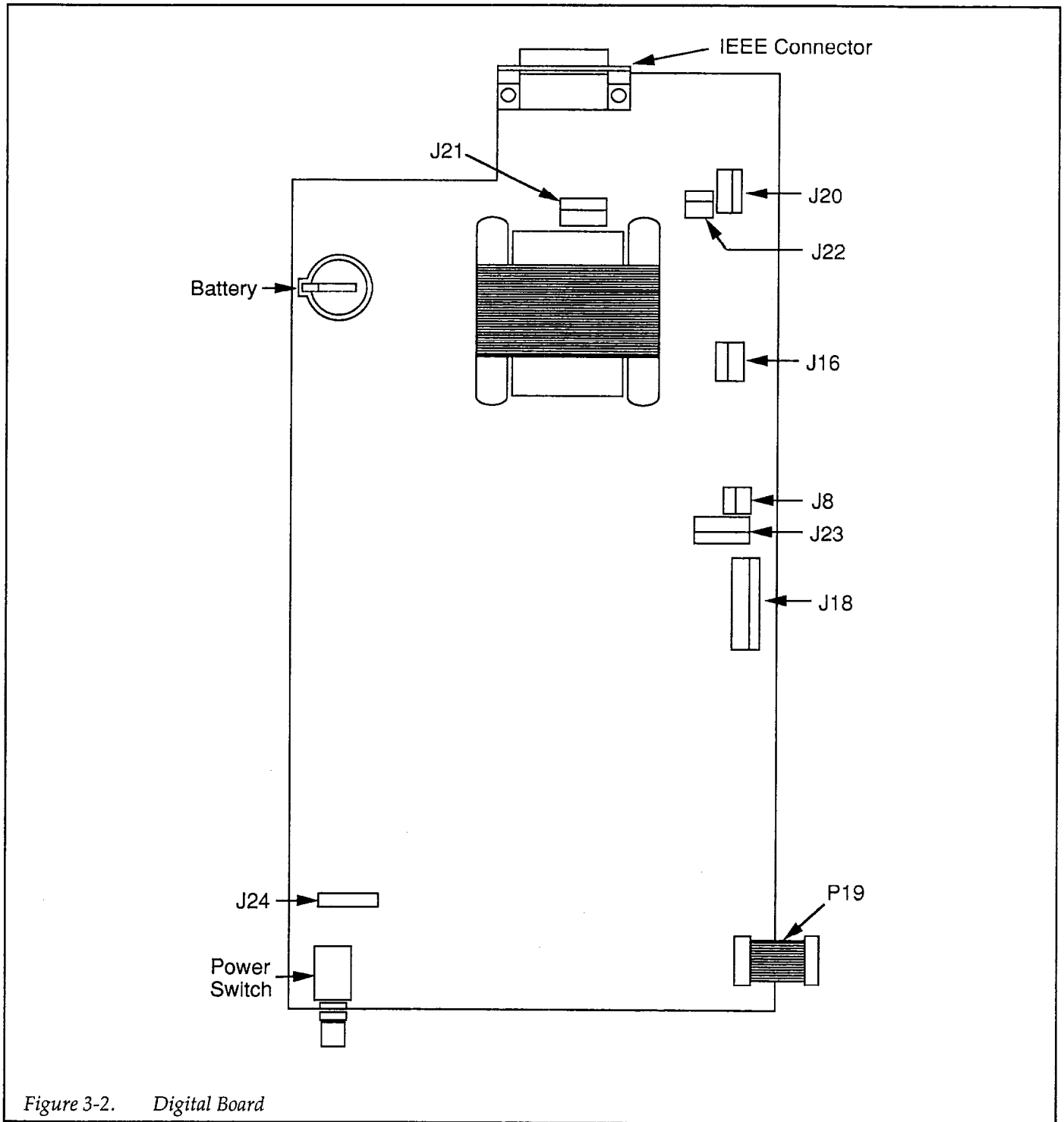

Figure 3-2. Digital Board



3. Wash the area again with fresh, clean methanol, allowing it to drain, flushing contaminants off the board.
4. Once the area is thoroughly cleaned, it should be dried with pressurized dry clean air or nitrogen. Do not use compressed air from an ordinary air compressor, as oil particles in the air could contaminate the circuit board.
5. After cleaning or parts replacement, check to see that any components connected to the Teflon® insulators are not physically touching the board or adjacent parts.

### 3.6 DISASSEMBLY INSTRUCTIONS

If it is necessary to troubleshoot the instrument or to replace a component, use the following disassembly procedure. Disassembly should be done in the order that it is presented since many steps depend on a previously performed procedure.

#### NOTE

Connector designations on the illustrations use either a "P" or "J" prefix. A "P" indicates that the connector is a plug type, while "J" indicates that it is a receptacle. For example, P10 is a plug connector that mates to receptacle J10.

#### WARNING

**Disconnect the line cord and any test leads from the instrument, and wait at least three minutes to allow high voltage capacitors to discharge before beginning disassembly.**

1. Remove the top cover as follows:
  - A. The top cover is secured to the chassis by six screws. Four are located at the top of the instrument and two are located at the rear. Remove those six screws.
  - B. Slide the top cover towards the rear of the instrument until it separates completely from the chassis.
2. Remove the bottom cover as follows:
  - A. If installed, remove the four plastic feet located on the bottom cover. Each foot is secured with a single screw.
  - B. The bottom cover is secured to the chassis by two screws located at the rear of the instrument. Remove those two screws.
  - C. Slide the bottom cover towards the rear until it completely separates from the chassis.

#### CAUTION

**When reinstalling the bottom cover, use the proper screws to install the four feet. Screws that are too long will cause damage to the internal circuit boards. The front feet are secured by #6-32x5/8" screws, the rear feet are secured by #6-32x1/2" screws.**

**If leaving the feet off in order to install the instrument in a rack, do not use the original screws to secure the bottom cover. Instead, use the four short screws (#6-32x1/4") supplied with the rack mount kit.**

3. If the cooling fan needs to be removed, proceed as follows. Otherwise, proceed to step 4.
  - A. Disconnect P22 (fan) from J22 on the digital board (see Figure 3-2).
  - B. Disconnect the ground wire from the rear panel.
  - C. Remove the four fasteners that secure the fan to the rear panel.
  - D. Pull the fan out of the instrument case.
4. Remove the output board (see Figure 3-3) as follows:

Note: The output board is mounted on the analog board adjacent to the rear panel.

#### WARNING

**To avoid burns from excessive heat, make sure that the heat sink on the output board is cool enough to handle. If the heat sink is hot, wait until it is cool before attempting to remove the output board.**

- A. Disconnect P16 from J16 on the digital board (see Figure 3-2).
- B. Remove the four screws that secure the output board assembly to the analog board.
- C. Grasp the heat sink and lift up the output board assembly a few inches. Disconnect P15 from J15 which is located on the analog board directly under the output board.
- D. Lift the output board out of the instrument case.
5. Remove the analog board (see Figure 3-4) as follows:
  - A. Remove the analog board shield. It is secured to the analog board with four screws.
  - B. Remove the inner shield. It is secured to the analog board with three screws.
  - C. Disconnect P19 (ribbon cable from digital board) from J19.
  - D. Disconnect P8 and P18 from J8 and J18 on the digital board.
  - E. Disconnect the connector for the OUTPUT LO banana jack from J27.
  - F. Disconnect the SMB triax connectors from J11, J12 and J13.





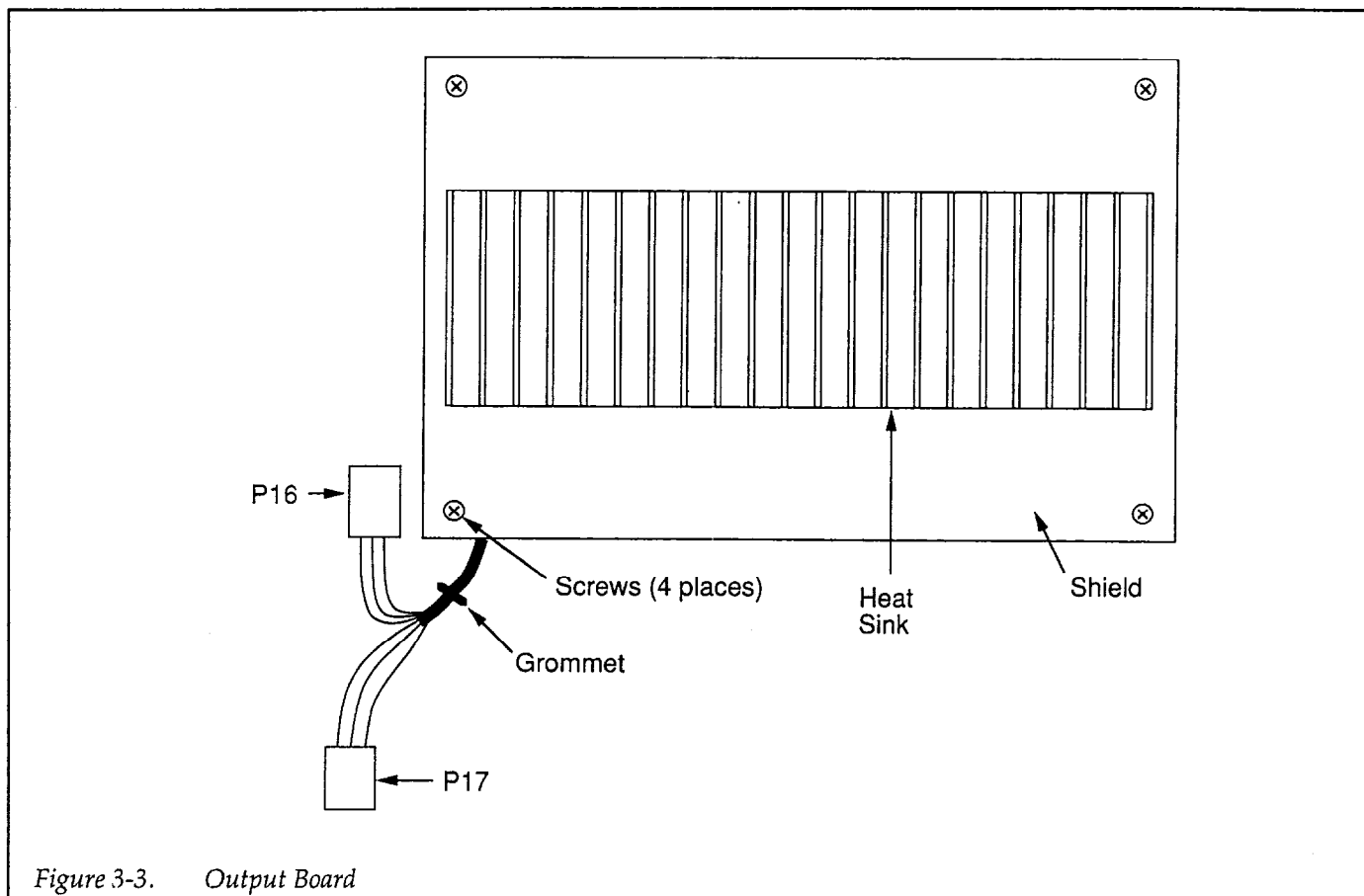

Figure 3-3. Output Board

- G. Place the instrument on its right side and, from the case bottom, remove the seven screws that secure the analog board to the mounting rails.
  - H. Place the instrument in the normal upright position and carefully manipulate the analog board assembly out of the instrument case.
  - I. Remove the bottom shield of the analog board. It is secured to the analog board by the five remaining screws accessible from the component side of the board.
6. Remove the rear panel assembly as follows:
    - A. Disconnect P20 (AC line filter) and P22 (fan) from J20 and J22 on the digital board.
    - B. At the back of the instrument, remove the two nuts that secure the IEEE-488 interface connector to the rear panel.
    - C. Remove the four screws that attach the rear panel to the side panels of the instrument. Two of these screws also secure the fan filter assembly to the rear panel.
    - D. To provide clearance, pull the rear panel outward a little and then disconnect P21 (Trigger and Interlock) from J21 on the digital board.
    - E. Separate the rear panel from the instrument case.

#### WARNING

To provide protection from possible electric shock, when re-assembling make sure the ground wires from the AC power outlet and cooling fan are connected to the rear panel.

7. Remove the digital board (see Figure 3-2) as follows:
  - A. Disconnect the display board ribbon cable from J24.
  - B. Place the instrument on its left side. From the bottom of the instrument case, notice that there are eight screws (seven slotted and one Phillips) securing the digital board to the three mounting rails. The Phillips head screw installs into a kep nut on the other side of the board. Remove this screw first and make sure not to lose the kep nut.
  - C. Remove the other seven screws that secure the digital board to the mounting rails. Be sure not to let the digital board fall when the last screw is removed.
  - D. Place the instrument in the normal upright position and remove the digital board from the case.





- E. Remove the top and bottom shield for the digital board. This shield assembly is secured to the board by four screws.
- 8. Remove the display board as follows:
  - A. At the front panel, pull off the rotary knob.
  - B. Remove each of the four decorative strips from the side panels as follows:
    - a. From inside the case, place a thin blade screwdriver into one of the holes where the decorative strip is secured.
    - b. Carefully push outwards until the strip disengages from one of the fasteners.
  - C. Carefully push outwards until the strip disengages from one of the fasteners.
  - D. Pull the strip away from the side panel.
    - Note: To reinstall, align the strip in the recessed part of the side panel and press the strip at the locations of the fasteners.
  - E. Remove the four screws that secure the front panel assembly to the side panels and disengage the front panel assembly from the chassis.
  - F. Loosen the four Allen set screws securing the bezel assemblies to the front panel. Remove the bezel assemblies from the front panel.
  - G. Lift the display board away from front panel.

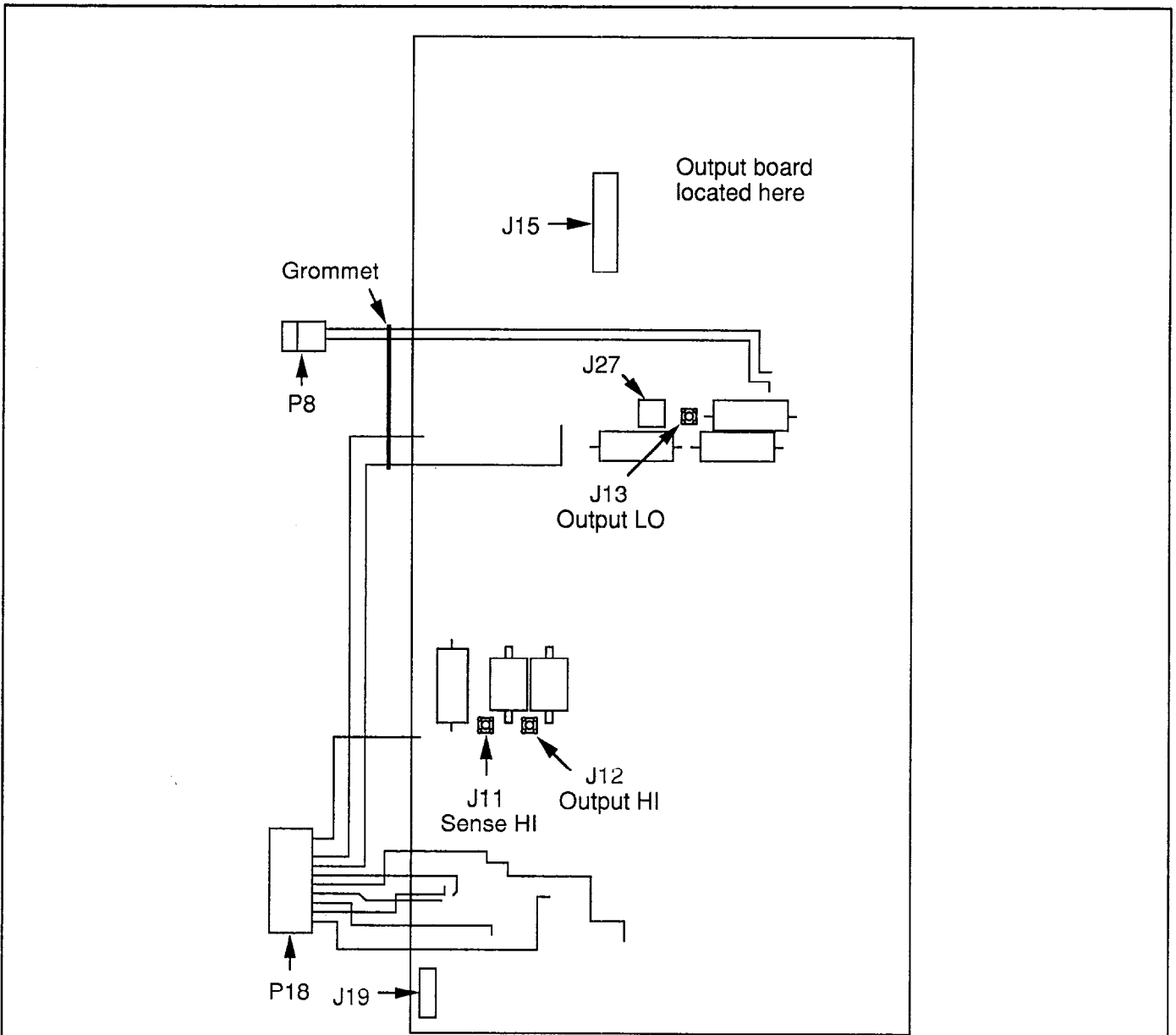

Figure 3-4. Analog Board (Shields Removed)



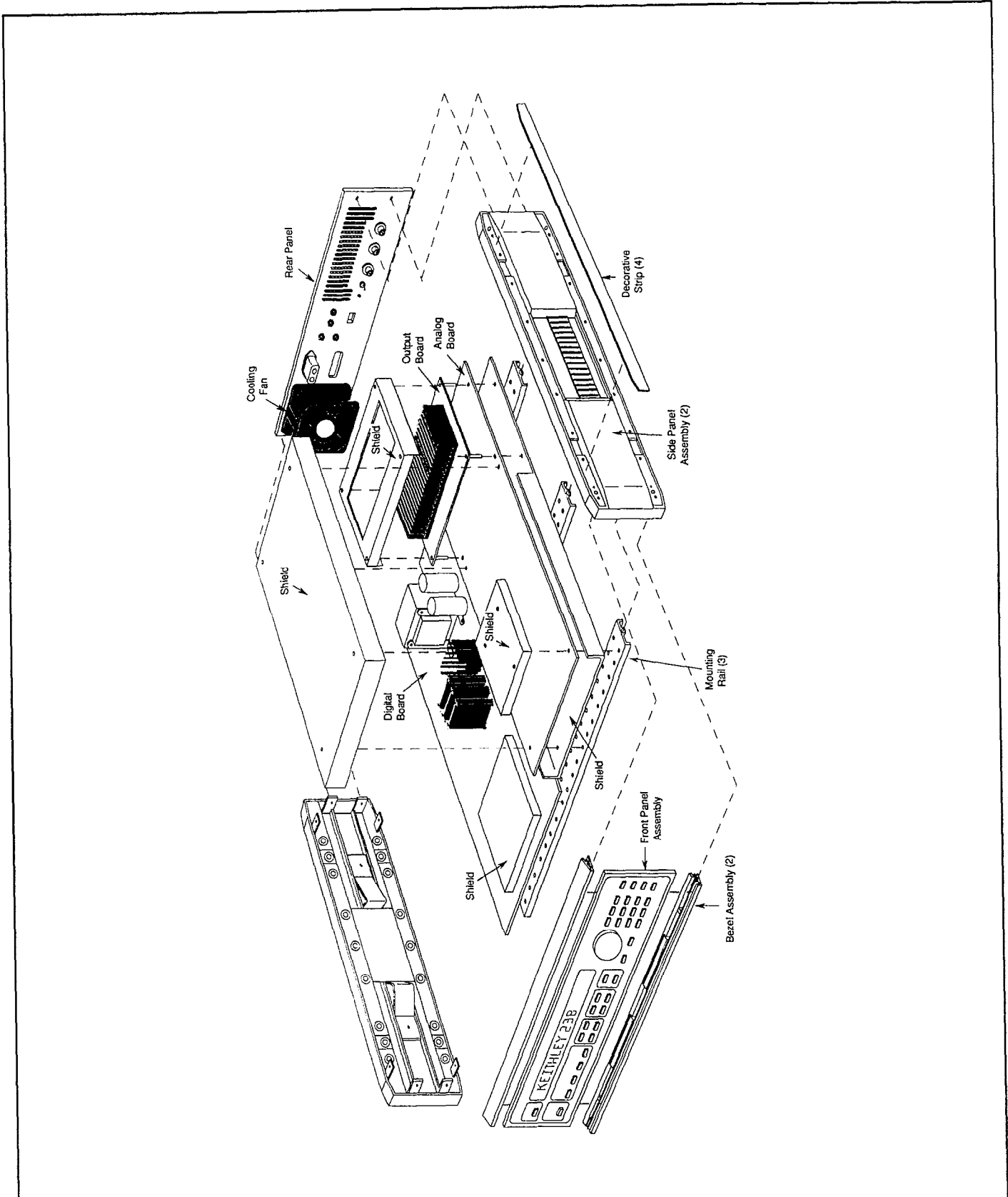

Figure 3-5 Model 238 Exploded View



- The instrument can be re-assembled by reversing the above procedure. Make sure that all parts are properly seated and secured, and that all connections are properly made. To ensure proper operation, shields must be replaced and fastened securely.

**WARNING**

To ensure continued protection against safety hazards, verify that power line ground (green wire attached to AC power receptacle) and fan ground are connected to the rear panel.

**3.7 SPECIAL HANDLING OF STATIC SENSITIVE DEVICES**

CMOS devices operate at very high impedance levels for low power consumption. As a result, any static that builds up on your person or clothing may be sufficient to destroy these devices, if they are not handled properly. Use the following precautions to avoid damaging them.

- ICs should be transported and handled only in containers specially designed to prevent static build-up. Typically, these parts will be received in anti-static containers of plastic or foam. Keep these devices in their original containers until ready for installation.
- Remove the devices from their protective containers only at a properly grounded workstation. Also, ground yourself with a suitable wrist strap.
- Handle the devices only by the body; do not touch the pins.
- Any printed circuit board into which the device is to be inserted must also be grounded to the bench or table.
- Use only anti-static type solder sucker.
- Use only grounded tip solder irons.
- Once the device is installed in the pc board, it is normally adequately protected, and normal handling can resume.

**3.8 TROUBLESHOOTING**

The troubleshooting information contained in this section is intended for use by qualified personnel having a basic understanding of analog and digital circuitry. The individual should also be experienced at using typical test equipment as well as ordinary troubleshooting procedures. The information presented here has been written to assist in isolating a defective circuit or circuit section. Isolation of a specific component is left to the technician. Note that schematic diagrams and component location drawings, which are an essential aid to troubleshooting, are included in Section 5.

**3.8.1 Recommended Test Equipment**

Success in troubleshooting complex equipment like the Model 238 depends not only on the skill of the technician, but relies on the use of accurate, reliable test equipment. Table 3-2 lists the equipment recommended for troubleshooting the Model 238. Other equipment, such as logic analyzers and capacitance checkers, could also be helpful.

**Table 3-2 Recommended Troubleshooting Equipment**

Equipment	Use
Five function DMM with 0.1% basic DCV accuracy, 10M input impedance	Power supply and DC voltage checks; analog signal tracing continuity, logic levels,
Dual-trace, triggered sweep oscilloscope, DC to 50MHz	Digital and analog waveform checks.
Digital frequency counter	Checking clock frequencies.

**3.8.2 Diagnostics**

The Model 238 has some internal diagnostic capabilities to aid in troubleshooting.

**Power-up and MEMORY TEST**

On power-up or when the Memory Test is run, the Model 238 performs a series of tests on its memory elements. If a failure occurs, one or more front panel messages are displayed.

Perform the following steps to perform the Memory Test:

- Enable MENU and use the rotary knob to display "MEMORY TEST".
- Press ENTER. If the test passes, the display will blank for a couple of seconds and display the next menu item. Otherwise, a failure will cause one or more front panel messages to be displayed.  
Note: The Memory Test can also be run by sending J1X over the bus.

The front panel messages associated with memory element failures are explained as follows.



Message	Explanation
CAL INVALID ERR	On power-up, this message will indicate that one or more calibration errors exist. The Model 238 needs to be re-calibrated.
CAL CONSTANTS ERR	One or more calibration constants are not within allowable limits. Default cal constants will be used. Try re-calibrating the Model 238. Repeated failures may indicate defective E <sup>2</sup> ROM (U33).
IOU CAL CHECKSUM	Checksum test of calibration constants failed. Try re-calibrating instrument. Repeated failures may indicate a defective E <sup>2</sup> ROM (U33).
UNCALIBRATED	There are no calibration constants stored in memory. The E <sup>2</sup> ROM (U33) may be defective. Note that the Source Measure light blinks.
IOU DPRAM FAILED	The dual-port RAM for the I/O controller has failed making the instrument non-functional. The DPRAM (U12) may be defective.
IOU EEROM FAILED	The E <sup>2</sup> ROM (U33) in the I/O controller has failed making the instrument non-functional.
DPRAM LOCKUP	The source/measure controller cannot respond to the I/O controller due to RAM (U13), EPROM (U17), or microprocessor (U25) failure. The instrument is non-functional.
DPRAM LINK ERR	Communications error in the DPRAM (U12) between the I/O controller and the source/measure controller. The unit is non-functional.
1F	IOU RAM (U30) failure. The unit is non-functional.
2F	IOU EPROM (U31) failure. The unit is non-functional.

NOTE: There are error messages associated with calibration and are covered in the calibration section of this manual.

## Display Test

When the display test is run all display segments and front panel lights are turned on for a few seconds. Perform the following steps to run the display test:

1. Enable MENU and use the rotary knob to display "DISPLAY TEST".
2. Press ENTER to run the test.  
Note: The memory test can also be performed by sending J2X over the bus.

## A/D Test Mode

The instrument can be placed in the A/D test mode which allows the A/D multiplexer (U1) to be stopped in any one of its A/D phases. This allows switching states to be checked and signal tracing to the A/D input (see A/D Multiplexing in paragraph 3.8.5).

1. Turn off the Model 238.
2. While holding in the MENU button, turn on the Model 238. Continue to hold in the MENU button until the MENU indicator turns on.

3. Use the rotary knob to display "A/D TEST". Note that the A/D converter is still running normally at this time.
4. Press ENTER. The following message will be briefly displayed:

ENTER TO EXIT

This is an instructional message indicating that once in the A/D test mode, pressing ENTER will exit the test mode allowing the A/D converter to run normally. The following message will then be displayed:

A/D ZERO TEST

This message indicates that the A/D converter is locked in the zero phase.

5. The instrument can be placed in any of the other A/D phases (A/D REF, A/D VOLTS and A/D AMPS) with the use of the SELECT buttons.
6. To exit from the A/D test mode, press ENTER.
7. To return the instrument to the normal source/measure display state, press MENU.

Note: The A/D test will remain on the MENU until power is cycled.



Table 3-3. Power Supply Checks

Step	Item	Component	Required Condition	Remarks
1	Line voltage switch	—	Set to 115V or 230V as required	Line voltage selection
2	Line fuse	—	Check for continuity	Remove fuse to check.
3	Line Power	—	Plugged into live receptacle; power on	
4	+5V Digital supply	VR1, pin2	+5V $\pm$ 0.25%	Reference to digital common.
5	$\pm$ 15V Analog supplies	VR3, pin3 VR4, pin3	+15V $\pm$ 1V -15V $\pm$ 1V	Reference to floating common.
6	$\pm$ 30V Analog supplies	VR5, pin2 VR6, pin3	+30V $\pm$ 2V -30V $\pm$ 2V	Reference to floating common.
7	+5V Analog supply	VR2, pin3	+5V $\pm$ 0.25%	Reference to floating common.
8	$\pm$ 150V Floating supply	J16, pin4 J16, pin1	+150V $\pm$ 20V -150V $\pm$ 20V	Reference to output common.
9	$\pm$ 15V Floating supply	J8, pin1 J8, pin2	+15V $\pm$ 1V +15V $\pm$ 1V	Reference to output common.
10	$\pm$ 24V Floating supply	J23, pin1 J23, pin4	+30V $\pm$ 6V -30V $\pm$ 6V	Reference to output common.

### 3.8.3 Power Supply Checks

Table 3-3 shows the various checks that can be made to the power supplies of the Model 238. In addition to the normal voltage checks, it is a good idea to check the various supplies with an oscilloscope for signs of noise or oscillations.

### 3.8.4 Analog Control Lines

Control lines, managed by the source/measure controller, are used to drive the various relays, switching FETs and analog switches associated with analog circuitry operation. That is, an appropriate voltage level present on a control line will cause the respective switch to close or open.

These control lines (located on schematic 238-126, page 1) drive relay coils, gates of switching FETs, and inputs of analog switches. The following summarizes the nominal voltage levels that should be present on the control lines to drive these switching devices.

#### NOTE

To check voltage levels on control lines, reference the measurement to floating common.

#### CAUTION

On the Model 238, remove the ground link from output common when using chassis grounded equipment to make measurements referenced to floating ground. Otherwise, erroneous measurements or possible instrument damage may result.

#### Relay Drive

K8, K9, K10, K11 and K12;  
0V = relay switch closed  
+5V = relay switch open

K1, K3, K4, K5, K6 and K15;  
0V = relay switch open  
+5V = relay switch closed

#### K1 (Output Module)

0V = relay switch open  
-15V = relay switch closed



**FET Switch Drive**

N-channel FET;

0V = switch closed (on)

-15V = switch open (off)

P-channel FET;

0V = switch closed (on)

+15V = switch open (off)

**Analog Switch Drive (U45, U48, U49 and U50)**

0V = switch closed

+5V = switch open

Other control lines that are not used to drive switching devices are described as follows:

**COMPLIANCE** — Used for compliance detection. When the Model 238 is in compliance, this control line is at 0V. Otherwise, +5V is on this line.

**POLARITY** — Used to provide the appropriate 10V reference for the clamping circuits. When the instrument is programmed for a positive (+) output, this control line is at nominally +10V. When programmed for a negative (-) output, this line is at nominally -10V.

**100mA RANGE BIAS** — Used to select the appropriate current limit to the output stage. With the instrument on the 100mA range (source or measure), this control line is at +5V. On the other current ranges this line is at 0V.

**3.8.5 Analog Switching**

Tables 3-4 through 3-8 provide the switching states of most of the analog circuit switching devices for the various operating conditions.

**Current Ranging** — Table 3-4 lists the switches that are closed for each of the nine current ranges. This table applies to both source and measure current ranges. Notice that on the 1nA range none of the current range relays are closed.

**Volts Ranging** — Table 3-5 lists the switches that are closed for each of the available voltage ranges. This table applies to both source and measure voltage ranges.

**Table 3-4. Analog Switching: Current Ranging**

Range	Relays Closed	Range Switches Closed
1A	K1*, K8	Q6-Q9, Q33, Q37, Q38, Q51-Q54, U50A, U50B
100mA	K8	Q5-Q9, Q37, Q38
10mA	K9	U45A, Q10, Q11
1mA	K9	U45A, Q12, Q13
100µA	K9	U45A, Q4, Q14
10µA	K9	U45A, Q4
1µA	K10	U45A, Q4
100nA	K11	U45A, Q4
10nA	K12	U45A, Q4
1nA	—	U45A, Q4

\*Output module

**Table 3-5. Analog Switching: Current Ranging**

Range	Relays Closed	FET Switches Closed
1.5V	K4, K6, K7	Q24, Q33, Q35, Q53
15V	K4, K6, K7	Q24
110V	K7	—
1100V	—	—

**Feedback** — As listed in Table 3-6, analog switches U48 and U49 are used for feedback switching. Each of these two devices has four individual switches and are identified by their circuit schematic pin numbers. The table lists the states of these switches for standby and operate conditions while programmed to source current and voltage.

**Sensing** — As listed in Table 3-7 three relays are used to select local or remote sensing. Note that when the instrument is programmed for remote sensing, the relay switches will default to the local sensing states when placed in standby. That is, relay K3 will open, and relays K15 and K5 will close whenever the instrument is placed in standby.





Table 3-6. Analog Switching; Feedback

Analog Switches		Source I Measure V		Source V Measure I	
Device	Pins	Standby	Operate	Standby	Operate
U48	6, 7	Closed	Open	Closed	Closed
U49	6, 7	Closed	Open	Closed	Closed
U48	2, 3	Closed	Open	Closed	Closed
U49	10, 11	Closed	Open	Closed	Closed
U48	10, 11	Open	Closed	Open	Open
U49	14, 15	Open	Closed	Open	Open
U48	14, 15	Open	Closed	Open	Open
U49	2, 3	Open	Closed	Open	Open

Table 3-7. Analog Switching; Sensing

Sense	Relays*		
	K3	K15	K5
Local	Open	Closed	Closed
Remote	Closed	Open	Open

\*Relay states with 238 in OPERATE. In standby, relays go to local sense states.

Output — For safety, there are two relays that are used to disconnect OUTPUT HI and SENSE HI from the rear panel output triax connectors. When the instrument is off, relays K1 and K2 are open. When turned on, these relay switches remain open until the instrument is first placed in operate. These two switches then remain closed while the instrument is powered on.

A/D Multiplexing — During normal operation, the A/D multiplexer (U1) continuously applies a sequence of signals to the input of the A/D converter. These signals include Zero, Reference and Measure (I or V). Only one signal is switched to the A/D input at one time. The switching speed and sequence varies according to how the instrument is programmed to operate.

In the A/D test mode (see paragraph 3.8.2) the A/D converter is locked up in the desired A/D phase. This allows multiplexer switch states to be checked and signal tracing to the A/D input to be performed. Table 3-8 identifies the switch that is closed during each A/D phase. The pin numbers of multiplexer U1 are used to identify each switch.

Table 3-8. Analog Switching; A/D Multiplexing

A/D Phase	U1 Switch Closed (pins)
Reference	6, 7
V Measure	14, 15
I Measure	10, 11
Zero	2, 3

### 3.8.6 Digital and Display Checks

The digital and display circuitry can be checked out by using the troubleshooting data found in Table 3-9 and 3-10.

Note: The firmware that controls the Model 238 is contained in two EPROMs (U17 and U31). If it is necessary to replace one or both of the EPROMs, make sure that both EPROMs installed in the instrument have the same firmware revision level. After installing new firmware, perform factory initialization to write firmware changes to the E2ROM. Factory initialization is performed by enabling MENU, displaying FACTORY INIT with the rotary knob, and then pressing ENTER.

#### CAUTION

The EPROMs are static sensitive devices that are susceptible to damage by routine handling. Be sure to handle the devices as explained in paragraph 3.7.



Table 3-9. Digital Circuitry Checks

Step	Item/Component	Required Condition	Remarks
1	U12, U13, U17, U30, U31 and U33	Pass RAM, EPROM, DPRAM and NVRAM tests on power up.	Display will lock if failure occurs.
2	U28, pin 18	TTL level pulse every 1msec	I/O controller VIA display clock
3	U28, pin 6 (PA4), pin 7 (PA5), pin 8 (PA6), pin 9 (PA7)	Switch data (+5V or 0V)	Data input to VIA when button pressed
4	U28, pin 11 (PB1), pin 12 (PB2)	Rotary knob data (+5V to 0V)	Data input VIA when rotary knob turned
5	U28, pin 19	Variable pulse train (0V to +5V)	Data output to display
6	U25, pins 34 and 35	2MHz TTL	Bus clock
7	U25, pin 37	+5V, $\pm 5\%$	Reset line (goes low momentarily on power up)
8	U27, pin 9	+5V signal pulsed 0V to +5V every 1msec	INT line
9	U27, pin 19	+5V (Logic "1")	RESET line
10	U27, pin 18	2MHz squarewave (0V to +5V)	Clock
11	U27, pin 28	Goes true (+0V) when command is sent	ATN line
12	U27, pin 24 (NDAC), 25 (NRFD), 26 (DAV), and data lines	See Figure 3-7 for required conditions	Handshake sequence
13	U14, pin 19	Variable pulse train (0V to +5V)	S/M controller VIA data to optos.
14	U14, pins 2-9 (PA0-PA7)	Variable pulse train (0V to +5V)	Data to VIA from A/D
15	U15, pins 34 and 35	2MHz TTL	Clock
16	U15, pin 37	+5V, $\pm 5\%$	Reset line (goes low momentarily on power up)





Table 3-10 Display Circuitry Checks

Step	Item/Component	Required Condition	Remarks
1.	P24, pin 15 and 16	+5V, $\pm 5\%$	+5V supply
2	U5, U6, U9 and U10; OUT1 thru OUT8	Variable pulses	Segment drivers
3	U4, pins 4-7, 14-17 U7, pins 4-7, 14-17 U8, pins 4 and 5	Variable pulses	Digit drivers
4	P24, pin 10	Depress any switch located in the first column of switch array on schematic (236-116).	Pulse present when button pressed.
5	P24, pin 9	Depress any switch located in the second column.	Pulse present when button pressed.
6	P24, pin 8	Depress any switch located in the third column.	Pulse present when button pressed.
7	P24, pin 7	Depress any switch located in the fourth column.	Pulse present when button pressed.



# SECTION 4

## Principles of Operation

### 4.1 INTRODUCTION

This section contains a general functional description of the Model 238. Detailed schematics and component location drawings are located at the end of this manual.

A simplified block diagram of the Model 238 is shown in Figure 4-1. The instrument may be divided into two sections; analog and digital circuitry. The analog and digital sections are electrically isolated from each other by the use of opto-isolators for control and communications. Separate power supplies for the analog and digital sections ensure proper isolation.

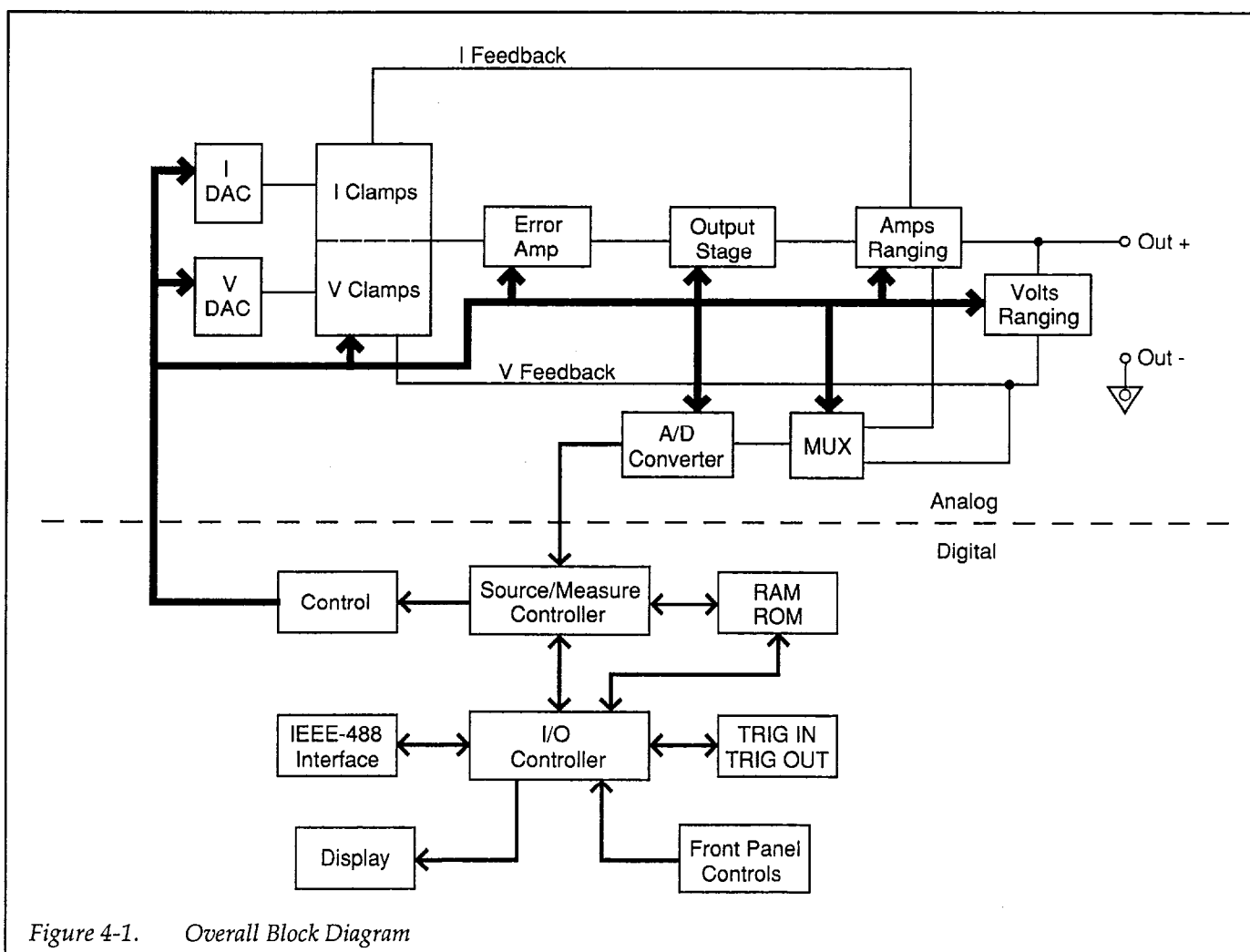

Figure 4-1. Overall Block Diagram



## 4.2 ANALOG CIRCUITRY

The heart of the source is an error amplifier that along with its complex scheme of feedback elements is configured as a bootstrap amplifier. Input stimulus for the amplifier is provided by two user-programmed digital-to-analog converters (DACs). The controlling function (current or voltage) and selected polarity of the source turns on one of four precision clamps allowing an input signal to be applied to the error amplifier. The output voltage from the DAC and the feedback configuration applies a voltage to the input of the error amplifier that will effect a constant level of current or voltage at the output.

Measurement is accomplished by routing properly conditioned feedback levels for voltage and current through a multiplexer to the analog-to-digital (A/D) converter.

Before proceeding to the details of circuit operation, it may be helpful to clarify what is meant by "controlling

function". If the instrument is programmed to source a specific current and it does indeed source that current, then it is considered to be current controlled. That is, current is the controlling function. If for some reason the instrument goes into compliance, the programmed current will not be sourced. Instead, the instrument sources a constant voltage (compliance voltage). Thus, voltage becomes the controlling function. Conversely, when programmed to source voltage, voltage is the controlling function unless the instrument goes into current compliance. In compliance, current becomes the controlling function.

### 4.2.1 V/I Control and Readback

A simplified schematic diagram of the V/I control and V/I readback circuitry is shown in Figure 4-2. The detailed schematic showing all circuit components is located on page 2 of drawing number 238-126.

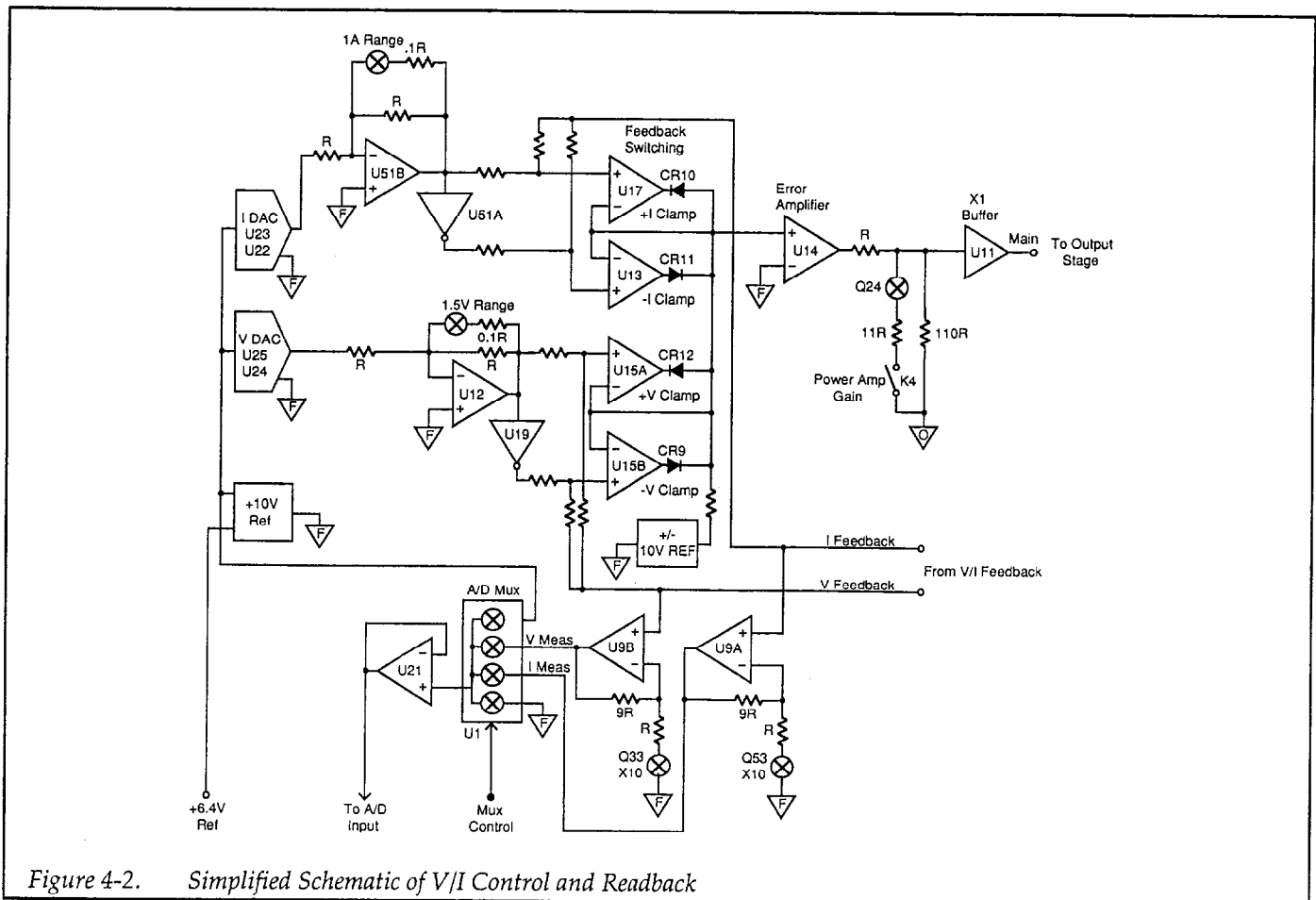

Figure 4-2. Simplified Schematic of V/I Control and Readback



Programming current and voltage sets the output voltage of the two digital-to-analog (DAC) circuits. Programming current controls the output of the I DAC (U23 and U22), and programming voltage controls the output of the V DAC (U25 and U24). Programming current or voltage for zero output will result with a 0V output from the respective DAC. Programming for a full scale output will result with a  $-10\text{V}$  output from the respective DAC.

The output voltage from the I DAC is applied to current clamps through resistor networks. Op amp U13 and diode CR11 form the negative current clamp (-I CLAMP). The output from the I DAC is inverted by the  $\times 1$  amplifier U51B ( $\times 0.1$  for the 1A range). The inverted output of U51B is again inverted by U51A. Op amp U17 and diode CR10 form the positive current clamp (+I CLAMP).

The output from the V DAC is inverted by the  $\times 1$  amplifier U12 ( $\times 0.1$  for the 1.1V range) and similarly applied to current clamps through resistor networks. Op amp U15A and diode CR12 form the positive voltage clamp (+V CLAMP). The inverted output of U12 is again inverted by U19. Op amp U15B and diode CR9 form the negative voltage clamp (-V CLAMP).

During operation, only one of the four precision clamps will be on at one time to control the error amplifier (U14). The controlling function and the programmed polarity (+ or -) will determine which clamp is on. The following example will explain how this occurs.

**Example 1:** This example is divided into two parts. Part 1 will explain circuit operation with the instrument sourcing a constant current. Part 2 will explain what happens when the source goes into voltage compliance.

**Part 1:** Assume that the instrument is sourcing  $+5\text{mA}$  with a  $27\text{V}$  compliance to a  $4\text{k}\Omega$  load. Under these conditions the instrument is not in compliance ( $5\text{mA} \times 4\text{k}\Omega = 20\text{V}$ ). Thus, current is the controlling function.

The I DAC outputs  $-5\text{V}$ . Thus, negative voltage appears at the non-inverting (+) input of U13 and positive voltage appears at the non-inverting (+) input of U17. The V DAC outputs approximately  $-3\text{V}$ . Positive voltage appears at the non-inverting (+) input of U15A and negative voltage appears at the non-inverting (+) input of U15B.

Since the instrument is programmed for a positive output, the  $+10\text{V}$  REF will apply a positive voltage to the common side of the clamps. This positive voltage will reverse-bias diodes CR11 and CR9B and prevent the -I CLAMP and -V CLAMP from turning on.

With the front end of the bootstrap amplifier set up as described,  $-5\text{V}$  will be fed back (via I FEEDBACK) to U17 and U13. The non-inverting (+) input of U17 will go to  $0\text{V}$  ( $-5\text{V} + 5\text{V} = 0\text{V}$ ) forward-biasing CR10. As a result, the +I CLAMP turns on.

The voltage drop across the load is  $20\text{V}$  ( $5\text{mA} \times 4\text{k}\Omega = 20\text{V}$ ). This voltage is scaled down to  $2\text{V}$  and inverted. This  $-2\text{V}$  is fed back (via V FEEDBACK) to U15A and U15B. The non-inverting (+) input of U15B will go positive keeping CR12 reverse-biased. As a result, the +V CLAMP remains off.

Current from  $+10\text{V}$  REF will flow into the +I CLAMP, which is turned on (remember, the other clamps are off). As a result, the feedback configuration and the I DAC output will apply a voltage to the error amplifier (U14) that will effect a constant  $+5\text{mA}$  output current.

**Part 2:** Assume the instrument is still programmed to source  $+5\text{mA}$  with a compliance of  $27\text{V}$ . However, for one reason or another, the load resistance changes to  $6\text{k}\Omega$ . This load change causes the source to go into compliance making voltage the controlling function.

With the  $4\text{k}\Omega$  load, the +I CLAMP is on making current the controlling function (as explained in the Part 1). When the load resistance is increased to  $6\text{k}\Omega$ , the voltage drop across the load would be  $30\text{V}$  ( $5\text{mA} \times 6\text{k}\Omega = 30\text{V}$ ). However, voltage is limited at  $27\text{V}$  and the source goes into compliance.

In voltage compliance, the  $27\text{V}$  is scaled down to  $3\text{V}$  and inverted. This  $-3\text{V}$  is fed back (via V FEEDBACK) to U15A. The non-inverting (+) input of U15A will go to  $0\text{V}$  ( $-3\text{V} + 3\text{V} = 0\text{V}$ ) forward-biasing CR12. As a result, the +V CLAMP will turn on.

Current from  $+10\text{V}$  REF starts flowing into the +V CLAMP. With less current flowing into the +I CLAMP, the voltage at the input of U14 decreases causing the output current of the source to decrease. The resultant feedback voltage to U17 will cause its (+) input to increase



above 0V causing CR10 to become reversed-biased. As a result, the +I CLAMP will turn off.

With the +V CLAMP on, the instrument is voltage controlled. The output from the V DAC and the feedback configuration will apply a voltage to the error amplifier (U14) that will effect a constant output voltage of +27V.

Bootstrap amplifier gain is controlled at the output of the error amplifier (U14) by the FET switch Q24 and relay K4. On the 110V and 1100V ranges, the switches are open and x110 gain is provided. On the lower voltage ranges the switches are closed providing x11 gain. Device U11 is a x1 buffer between the V/I control circuit and the output module.

Measurement is accomplished by routing properly conditioned voltage feedback levels (I FEEDBACK and V FEEDBACK) through a multiplexer to the analog-to-digital (A/D) converter. Op amp U9A is configured as a non-inverting amplifier for I FEEDBACK. On the 1A range, the FET switch Q53 is closed providing x10 gain. On the other current ranges, the FET switch is open configuring U9A as a unity gain amplifier. Op amp U9B is configured as a non-inverting amplifier for V FEEDBACK. On the 1.5V range, the FET switch Q33 is closed providing x10 gain. On the higher voltage ranges, the FET switch is open configuring U9B as a unity gain amplifier. The four signals (+10V reference, V Measure, I Measure and floating common) are multiplexed (U1) and routed to the A/D converter via buffer U21.

## 4.2.2 Output Module

The output stage of the bootstrap amplifier basically consists of a class AB circuit whose bias is controlled by the output of the error amplifier. The simplified schematic diagram of the output module is shown in Figure 4-3. The detailed schematic of the output stage is found on drawings 238-166 and 238-126 (page 2).

### Low Current Ranges

At the heart of the output stage are power transistors Q21 and Q19. The collector of Q21 is effectively connected to the +150V, 120mA power supply, while the collector of Q19 is effectively connected to the -150V, 120mA power supply.

When programmed for a zero output, both Q21 and Q19 are zero-biased (off). The +150V supplies are dropped across the high impedance of these two transistors. As a result, zero voltage is present at the output (floating common to output common). When the source is programmed for a positive output, Q21 becomes forward-biased (on). The voltage drop across Q21 becomes less than +150V. As a result, the voltage present at the output is the difference between the supply voltage (+150V) and the voltage drop across Q21. For a positive output, Q19 is reverse-biased (off) keeping the negative supply isolated from the output.

Circuitry for a negative output functions in a similar manner. When the source is programmed for a negative output, Q19 becomes forward-biased, resulting with a negative voltage present on the output. Transistor Q21 is reverse-biased isolating the output from the positive supply.

Bias for the two power transistors are provided by the +30V supplies and two 15V zener diodes (VR10 and VR9). This bias circuit is referenced to floating common in order to maintain the bases of the transistors at a voltage that is higher than the output so that they can be forward-biased. Bias control is performed by the output of the error amplifier (MAIN drive). The polarity and magnitude of MAIN determines which transistor is forward-biased and the amount of bias current that in turn determines the magnitude of the output voltage. For example, as a positive MAIN becomes more positive, more bias current is delivered to the base of Q21 resulting in a higher output voltage.



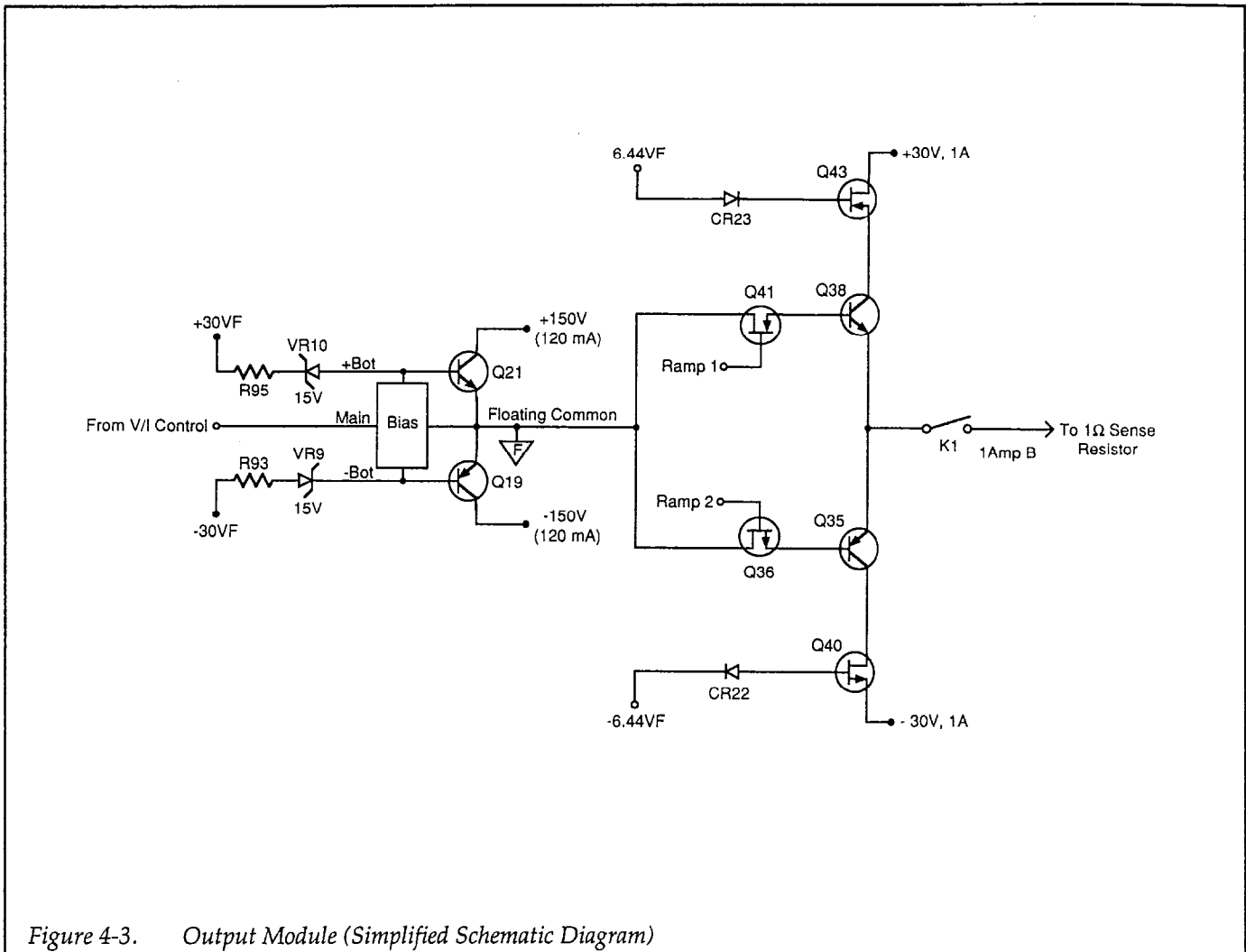

Figure 4-3. Output Module (Simplified Schematic Diagram)

### 1A Current Range

When the 1A range is selected, relay K1 and switches Q41 and Q36 are closed. The drive for the 1A stage is provided by the 1nA-100mA stage. For low output currents (0 to 20mA), the 1nA-100mA stage is used. As the current is increased, the transistors in the 1A output stage start to turn to provide output current up to 1A. To obtain the full voltage swing on the output, transistors Q43 and Q40 are driven by 6.44 zeners (VR1 and VR2).

### 4.2.3 V/I Feedback

A simplified schematic diagram of the V/I feedback circuitry is shown in Figure 4-4. The detailed schematic of this circuitry is provided by page 3 of drawing 238-126.

**Amps Ranging** — Current range selection is accomplished by activating the appropriate range FET and/or relay. The nominal range resistances, relays and FETs for each of the nine current ranges are shown in the illustration (Figure 4-4). The FET labeled QAB for the 100mA range is actually a composite P and N-channel FET. A more detailed look at the 100mA range is shown in Figure 4-5. In reality, QA is comprised of P-channel FETs Q8 and Q9, and QB is comprised of N-channel FETs Q6, Q7, Q37 and Q38.

Without special circuitry, current measurement range changes may cause voltage spikes to occur at the output. Voltage spikes are caused by contact bounce of the selected range relay. These spikes occur too fast for the bootstrap amplifier to react to the change in feedback voltage. As a result, the system cannot adjust itself accordingly to maintain a steady voltage output.

+

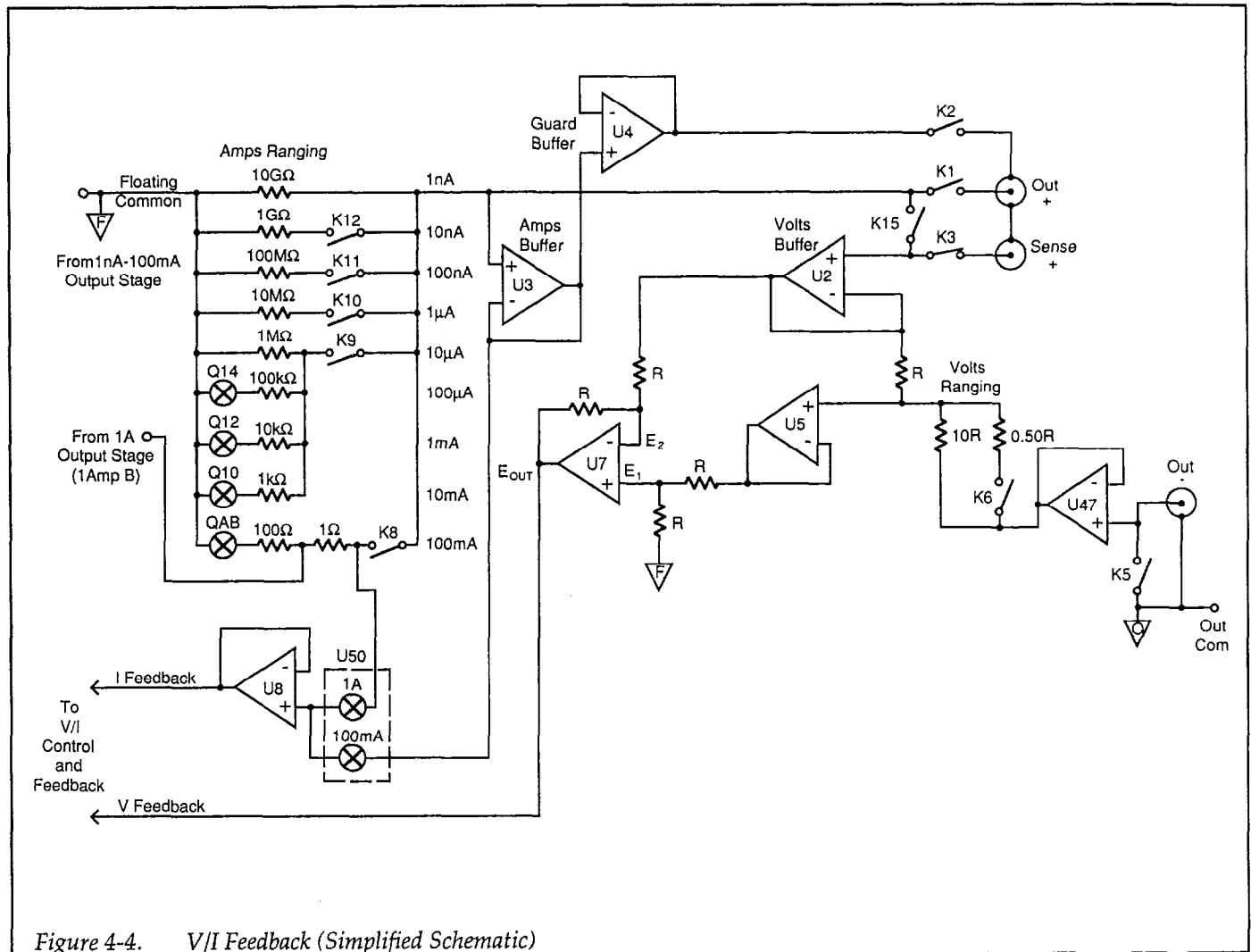

Figure 4-4. V/I Feedback (Simplified Schematic)

The Model 238 resolves this problem by using circuitry that, in effect, shunts the current ranges with a 100Ω resistor whose voltage drop ramps in a linear fashion towards 0V. This slow rate of voltage change allows the system to adjust itself keeping the output voltage constant (spike free). The circuitry that accomplishes this consists of FETs QA and QB, and the +15V-to-0V ramps that control them.

The following sequence takes place when a current measurement range change occurs:

1. Relay K8 closes.
2. The appropriate ramp is activated (RANGE 2 RAMP for + polarity, or RANGE 1 RAMP for - polarity). The ramp on the gate of the appropriate FET results

with a corresponding voltage ramp across the 100Ω resistor.

3. The other ramp is activated. Turning on the second FET increases the current carrying capability of the circuit. With both FETs fully on, the current ranges are shunted by the 100Ω resistor.
4. The new range relay and/or FET is activated.  
Note: If the 100mA range is the new range, it is already selected. The range change sequence stops at this point. If a different range is selected, continue on to the next steps.
5. The two voltage ramps are disabled in reverse order.
6. Relay K8 opens completing the range change.

When the 100mA source range is selected, K8 closes and both ramps are activated to turn on both FETs. As long as the 100mA range is selected, 0V is maintained at the gates of the FETs to keep them on.

+



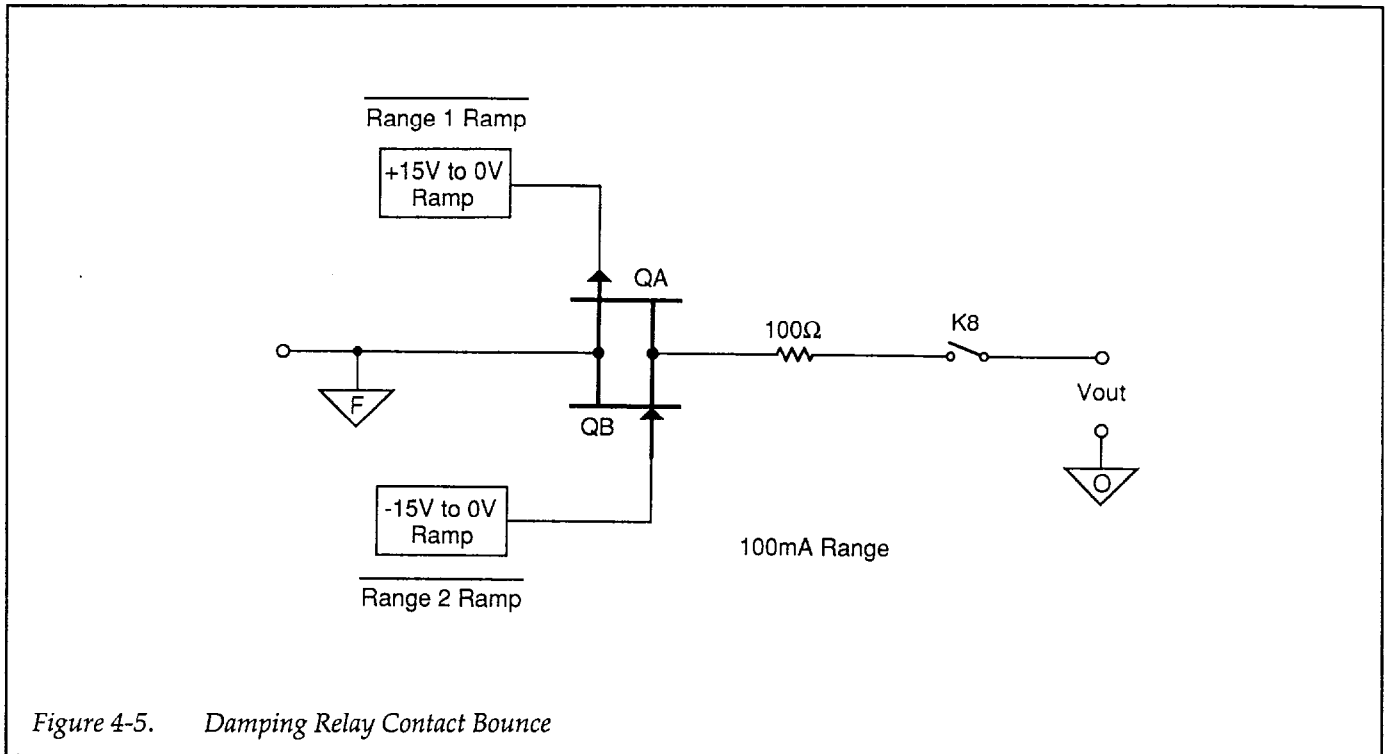

Figure 4-5. Damping Relay Contact Bounce

Op amp U3 is a unity gain amplifier that serves as a buffer between the output and I FEEDBACK. I FEEDBACK is fed back to V/I Control and Readback where it completes the feedback loop and is also routed to the A/D converter for measurement. On the 1A range, the 1AMPB output is switched directly to U8 (via U50), bypassing U3.

Guard — The x1 output of U3 is also routed to another x1 buffer amplifier (U4) whose output is used as the driven guard for the instrument. Buffer U4 isolates the driven guard from I FEEDBACK.

Volts Ranging and Sensing — The voltage range resistors are part of a voltage divider network. In general, OUT + is applied to the top of divider. The output of the divider is then routed to a differential amplifier. The other input to the differential amplifier is effectively OUT -. The output of the x1 differential output is then fed back to the V/I Control and Readback circuitry.

Op amp U2 is configured as a unity gain amplifier that serves as a buffer between the output and volts ranging circuitry. In local sense (K15 closed, K3 open), the output is accessed internally. In remote sense (K15 open, K3

closed), the output is accessed at the load. The x1 output of U2 is applied to the negative (-) input of the differential amplifier (U7).

The output of U2 is also applied to the top of the voltage divider for volts ranging. The bottom of the voltage divider network is connected to output common (OUT -) via op amp U47 which is configured as a x1 buffer. In local sense (K5 closed), OUT - is accessed internally. In remote sense (K5 open), OUT - is accessed at the load.

Volts range relay K6 determines the resistance of the bottom leg of the voltage divider. Table 4-1 identifies the relays for each voltage range. The output of the voltage divider is routed to the + input of the differential amplifier (U7) via op amp U5 which serves as a x1 buffer.

Op amp U7 is configured as a x1 differential amplifier. The output voltage (VOUT) of this amplifier will be the algebraic difference of its two inputs ( $E_1 - E_2 = V_{OUT}$ ). VOUT (V FEEDBACK) is routed back as a bootstrap amplifier feedback loop and also to the A/D multiplexer for measurement.





**Table 4-1 Volts Range Relays**

238 Range	Relays Energized
1.5V	K6
15V	K6
110V	None

### 4.3 A/D CONVERTER

The Source Measure Unit uses a constant frequency, variable pulse width, analog-to-digital converter. The schematic diagram for the A/D converter is located on page 3 of drawing 238-106.

Reading conversions start with a charge balance phase and end with a single slope phase, thus producing two sets of counts from U47 back to the pre-scale counter (U21) and VIA of the source/measure controller.

The A/D input is applied to current offset resistors R63 and R64. The input current is applied to the gate of Q4 via FET switch Q2 converting the bipolar +10V input to a unipolar current. Operational amplifier U50 and Q4 form an integrator with capacitor C63. This integrator ramps in a positive direction (since the current is negatively offset) until it reaches a threshold, or until a timebase interval occurs and switches on a balance current. This continues for a length of time that is determined by the value in register U44 which is programmed by the source/measure controller.

Device U45 is an 8 bit magnitude comparator which continuously compares the set value to the count value in counter U46. When these two numbers match, the output on pin 19 of U45 stops the A/D converter, thus signaling the end of the charge-balance phase. After determining that the charge balance has stopped (by monitoring counts or timing out), the software sets the final-slope balance line high. This clears U46 making it ready for a new charge-balance phase, and starts the final-slope phase of the A/D converter.

The final-slope phase essentially removes all charge remaining on the integrator by ramping the output of U50 to 0V. Counts are accumulated during the final-slope and used for calculation of the effective input signal. The A/D converter is run through a number of phases that

are used to null any error signals present in the A/D or analog front end.

The time base for the A/D converter is provided by an oscillator that consists of inverter U57 and crystal Y2. The 7.68MHz time base, which is a multiple of 60Hz, is divided by counters U41 and U40 to provide system timing functions for charge balance control. The 7.68MHz is fed directly to NOR gate U47 where it is gated on and off by the rest of the A/D function. The A/D power supply reference voltages, -10V, and +5V are derived from operational amplifier U56 and associated circuitry. These are reference voltages used in generating currents and thresholds for the A/D converter.

### 4.4 DIGITAL CIRCUITRY

The schematic diagrams for the digital circuitry are located in last section of this manual, drawing number 238-106.

The Source Measure Unit is controlled by two 6809 8-bit 2MHz N-MOS microprocessors. These two microprocessors coordinate all instrument functions. These include running the display and keyboard, servicing the IEEE-488 interface, and control of all analog functions.

#### 4.4.1 I/O Controller

The schematic diagram for the I/O controller is provided on page 1 of drawing 238-106.

The I/O controller controls the display and front panel controls, the IEEE-488 interface, test fixture lid closure detection, and TRIGGER IN and TRIGGER OUT. It also maintains calibration constants, and contains the major portion of the operating system for the instrument.

At the heart of the I/O controller system is an 8-bit 68B09 microprocessor running at 2MHz. The system master oscillator Y1 is an 8MHz canned crystal oscillator. I/O controller peripherals include a 64K X 8 ROM (U31) which contains the program memory, a 32K X 8 static CMOS RAM (U30) which is battery backed up via U29 and the battery (BT1). Calibration constants are stored in non-volatile memory (U33; E<sup>2</sup>ROM). A versatile interface adapter (U28) provides peripheral interface to the 6809 microprocessor. It is primarily used to interface with the display and keyboard. It is also used to interface TRIGGER OUT and TRIGGER IN, as well as monitor the test



fixture lid detect interface. A 9914 IEEE-488 standard interface (U27) is combined with two transceivers (U34 and U35) to provide the interface function. All of these peripheral chips are interfaced to the 6809 via a programmable logic device (U26; PAL 16L8).

A NOR gate package (U32) is used to provide protection for calibration constants stored in non-volatile memory (U33) during power-up and power-down.

A power-up reset control circuit (U36) guarantees a delayed reset after power-up and a prompt reset on power-down by sensing power supply threshold.

#### 4.4.2 Source/Measure Controller

The schematic diagram for the source/measure controller is provided on page 2 of drawing 238-106.

This controller system also uses a 68B09 microprocessor (U15). As with the I/O controller (see previous paragraph), it derives its 2MHz operating frequency from the 8MHz crystal (Y1). The peripherals for this 6809 include 32K of ROM (U17), 32K of static RAM (U13), and a versatile interface adapter (U14) which provides interface to the analog circuitry as well as a few other miscellaneous functions.

Devices U18, U19 and U58 are binary counters that form the core of a software watch-dog timer. This timer monitors software execution of both CPUs via lines that are regularly toggled. If any line fails to toggle within approximately 4msec the entire system will be reset.

As with the I/O controller, all the peripheral chips of the source/measure controller are decoded and controlled by a programmable logic device (U16; PAL 16L8). A/D control as well as A/D counts accumulation are performed by the VIA (U14) with a prescale counter (U21). Inverters (U23) provide a software selectable enable for the high voltage converter in the Model 237 only.

#### 4.4.3 Communications

The schematic diagram for the communications circuitry is located on page 4 of drawing 238-106.

Communications are provided by opto-couplers that serve as an interface between the source/measure controller and the analog circuitry. This particular circuit is fairly unique in that control signals are sent through two optos that are driven 180° out of phase with one another to provide immunity from false glitching.

The outputs of the complimentary opto-couplers are decoded by programmable logic device U1 (PAL 20L10). From U1, the signals are sent to various places on the analog board by decoder U39 which determines one of four clock paths as set by the bank select signals 0 and 1 which are also derived from U1. This circuit topology provides for a very reliable communications scheme such that the analog circuitry can never receive false data.

Opto-couplers AT1, AT2, AT3, AT7 and AT8 are all involved in the transmission of clock, data, strobe, and the two bank select signals from the VIA of the source/measure controller to the analog board. Opto-coupler AT5 returns a CV/CC constant voltage or constant current level signal to the source/measure controller so that the present state of the analog output can be determined. The A/D converter counts are returned to the microprocessor of the source/measure controller by AT6 which is a high speed opto-coupler.

#### 4.4.4 Display Circuitry

The schematic diagram for the display circuit is provided on drawing 236-116.

The display, which is controlled by the I/O controller, is basically an 18-digit alpha-numeric LED display. It consists of nine two-digit display elements (DS1 through DS9). Each of these display elements are multiplexed in a matrix fashion. Each display digit has its common cathode connected to sink drivers (U4, U7 and U8). These sink drivers are switched on in a rotating fashion.

The display is divided into two banks of ten columns such that the DS1 left digit and DS6 left digit are on simultaneously, as can be evidence by the common connections of the inputs of U4 pin 3 and U7 pin 8. This allows the display to be refreshed faster, thus eliminating flicker associated with line frequency beating with lighting and such. The front panel indicator LEDs (DS10 through DS29) are driven in a similar manner by sink drivers of U8. The anodes of the two separate banks of display elements are driven by source drivers U5 and U6 (left bank), and U9 and U10 (right bank). These are serial input, par-



allel output combination shift register/drivers. They interface directly to the I/O controller VIA clock data interface. A strobe is provided by software to load the outputs of the drivers with data. The displays are indexed at a 100Hz (1ms) rate.

Circuit components U1 and U2 provide a timer function that allow the selection of either a bright or dim digit and is used for flashing cursor digits. A counter (U2) times out after 256µsec and bit 16 of the two serial bank source drivers is fed back into U1 pin 12 and U1 pin 6. Depending on the states of these bits, the LEDs will be on for the entire 1msec duration or 1/4 (256µsec) duration. The column drivers are selected by a one-of-ten decoder (U3) which is directly driven from the VIA of the I/O controller. These columns, as they are selected, also select columns in the front panel key switch matrix through diodes CR1 through CR 10. The column driven low, and the four lines fed back to the VIA of the I/O controller identify which key is pressed.

## 4.5 POWER SUPPLY

The schematic diagram for the power supply is located on page 4 of drawing 236-106.

The power supply consists of an off line transformer (T1) which has selectable 115/230V operation. It is essentially two 115 volts primaries either in series or parallel. In parallel with one of the primary windings is the cooling fan allowing it to always operate on 115V. The line select switch (S2) allows user selectable line voltages. Switch S1 is the main power switch, F1 is the system fuse, and J2 is a rear panel mounted line filter connector. The secondary of the transformer provides all of the power supply voltages.

The digital power supply (gray transformer secondaries on schematic) is capable of delivering +5V at 1.2A to

power all digital and front panel circuit components. Full wave rectification is provided by the bridge rectifier CR1. Capacitors C106 and C107 provide spike suppression, while C4 provides filtering. Voltage regulation is provided by VR1 with capacitor C24 on its output for stability.

The 15V and 30V analog supplies are derived from the orange colored secondaries. The 15V power supply consists of a bridge rectifier CR4, filter capacitors C53 and C55, 15V regulators VR3 and VR4, and stability capacitors C91 and C92. A voltage doubler circuit consisting of diodes CR2, CR3, CR6 and CR7, and storage capacitors C52, C54, C56 and C57 combine with adjustable regulators VR5 and VR6, and resistors R6, R7, R8 and R9 to provide the 30V outputs.

The +5V analog supply (brown secondaries) consists of the bridge rectifier CR5, filter capacitor C7, regulator VR2, and output capacitors C93 and C15. This power supply provides +5V for analog functions.

The 150V supply (yellow secondaries) is provided for the bootstrap amplifier. A bridge rectifier is configured from four diodes; CR8, CR9, CR10 and CR11. These diodes rectify and use capacitors C58 and C59 as storage elements. A 15V analog supply is derived from a shunt regulator circuit consisting of resistors R73 and R74, and regulators VR7 and VR8 in parallel with capacitors C95 and C96.

The 30V supply (blue, white/brown and blue/white secondaries) is used to drive the 1A output stage. Bridge rectifier CR12 provides full-wave rectification while R80, R90, C110 and C119 suppress diode spikes. Triac Q7, zener diodes VR9 and VR10, and resistor R81 provide a clamping circuit that guarantees that the F1 fuse will clear when the instrument is set for 115V operation while connected to the 230V line. Minimum load is guaranteed by resistors R94 and R95. Filtering is provided by capacitors C10 and C118.





# SECTION 5

## Replaceable Parts

---

### 5.1 INTRODUCTION

This section contains replacement parts information, component location drawings and schematic diagrams for the Model 238.

### 5.2 PARTS LISTS

Parts are listed alphanumerically in order of their circuit designations. The first parts list contains information for the display board of the Model 238. The next parts list contains information for the digital board of the Model 238. The next parts list contains information for the analog board of the Model 238. The next parts list contains information for the output module. The last parts list contains information on miscellaneous parts that do not pertain to any of the pc boards.

### 5.3 ORDERING INFORMATION

To place an order, or to obtain information concerning replacement parts, contact your Keithley representative or the factory. See inside front cover for addresses. When ordering, include the following information:

- Instrument Model Number
- Instrument Serial Number
- Parts Description
- Circuit Designation (if applicable)
- Keithley Part Number

If an additional service manual is required, order part number 238-902-00. The manual package will contain the service manual and any applicable addenda.

### 5.4 FACTORY SERVICE

If the instrument is to be returned to the factory for service, please complete the service form which follows this section and return it with the instrument.

### 5.5 SCHEMATIC DIAGRAMS AND COMPONENT LOCATION DRAWINGS

Schematic diagrams and component location drawings follow the appropriate replaceable parts list for that particular board.



**TABLE 1. MODEL 238 ANALOG BOARD, PARTS LIST**

<b>CIRCUIT DESIG.</b>	<b>DESCRIPTION</b>	<b>KEITHLEY PART NO.</b>
C12,16	CAP,22PF,2.5%,630V,POLYPROPYLENE	C-405-22P
C124	CAP,150PF,1%,500V,MICA	C-209-150P
C127,128	CAP,68PF,2.5%,630V,POLYPROPYLENE	C-405-68P
C129	CAP,1000PF,10%,1000V,CERAMIC	C-64-1000P
C13,17,19,135, 142,150,151, 152,160,161	CAP,15PF,5%,100V,CERAMIC	C-372-15P
C130,140,141, 148,149	CAP,1000PF,1%,50V,CERMANIC	C-347-1000P
C131	CAP,47000PF,10%,100V,EPOXY	C-371-47000P
C132	CAP,10PF,10%,1000V,CERAMIC	C-64-10P
C132	CAP,10PF,10%,1000V,CERAMIC	C-64-10P
C133	CAP,15PF,10%,200V,CERAMIC	C-406-15P
C138,139,159	CAP,5PF,10%,1000V,CERAMIC	C-64-5P
C143,144	CAP,10PF,5%,100V,CERMANIC	C-372-10P
C153,154	CAP,15PF,5%,100V,CERAMIC	C-372-15P
C157	CAP,680PF,10%,1000V,CERAMIC	C-64-680P
C158	CAP,470PF,5%,500V,POLYSTYRENE	C-138-470P
C170..175, 177..214, 216..223	CAP,..1UF,20%,50V,CERAMIC	C-365-.1
C176,215, 224..246	CAP,..1UF,20%,50V,CERAMIC	C-237-.1
C18	CAP,39PF,2%,50V,CERMANIC	C-348-39P
C20	CAP,1500PF,10%,1000V,CERMANIC	C-64-1500P
C21	CAP,270PF,2.5%,630V,POLYPROPYLENE	C-405-270P
C22,120	CAP,560PF,2.5%,630V,POLYPROPYLENE	C-405-560P
C23	CAP,100PF,2.5%,630V,POLYPROPYLENE	C-405-100P
C24,121	CAP,220PF,2.5%,630V,POLYPROPYLENE	C-405-220P
C25	CAP,8PF,2.5%,630V,POLYPROPYLENE	C-405-8P
C26,122,123	CAP,33PF,2.5%,630V,POLYPROPYLENE	C-405-33P
C28,37	CAP,.01UF,10%,1000V,CERAMIC	C-64-.01
C39	CAP,3300PF,10%,100V,CERMANIC	C-430-3300P
C40,41,134, 156,162	CAP,150PF,1%,100V,CERMANIC	C-372-150P
C43	CAP,1UF,20%,50V, CERAMIC	C-237-1
C50,51	CAP,.01UF,20%,50V,CERAMIC	C-365-.01
C54,76,98,101, 102,115,155	CAP, 10UF,-20+100%,25V,ALUM ELEC	C-314-10
C6	CAP,22PF,10%,1000V,CERAMIC	C-64-22P
C8	CAP,150PF,10%,1000V,CERAMIC	C-64-150P
C9,10	CAP,33PF,10%,1000V,CERAMIC	C-64-33P
CR1..4,7,22..26, 28..33	DIODE,IN3595 (DO-7)	RF-43
CR34	DIODE,BRIDGE,DF10M	RF-79
CR5,6	DIODE,SILICON,SCHOTTKY,SB120	RF-78

CR9..16,19,20	DIODE,SILICON,IN4148 (DO-35)	RF-28
E1	SURGE ARRESTOR FOR P18 ASS'Y GROMMET	SA-3 GR-6
J11..13	CONN,SMB,MALE,P.C. MOUNT	CS-545
J15	CONN,MALE,15 PIN	CS-612-15
J19	CONN,DUAL 7-PIN-BERG	CS-389-5
J27	CONN,MALE,2PIN	CS-288-2
K1,8	RELAY, (SPST)	RL-141
K12,15	RELAY (SPST)	RL-117
K2,4..16 20	RELAY,REED, HI VOLTAGE	RL-119
K3	RELAY,REED, HI VOLTAGE	RL-129
K9,10,11	RELAY (SPST)	RL-117
P18	CONNECTOR HOUSING (10 PIN MOLEX)	CS-287-10
PS	CONNECTOR, HOUSING	CS-287-3
Q18	TRANS,N CHANNEL JFET,SELECTED J210	236-601
Q19,31	TRANS,NPN SILICON,2N3904 (TO-92)	TG-47
Q24	TRANS,N CHANNEL JFET,SELECTED J210	TG-167-1
Q25..28	TRANS,NPN COMP SILICON AMP,2N5089	TG-62
Q29	TRANS,PNP SILICON 2N3906 (TO-92)	TG-84
Q32,43,44,46,48	TRANS,CURRENT REGULATOR,CR430	TG-219
Q36	TRANS,CURRENT REGULATOR,CR120	TG-159
Q39,40	TRANS,N CHANNEL FET,2N4392 (TO-92)	TG-128-1
Q4..7,10..14, 33,35,37,38, 51..54	TRANS,SELECTED N CHANNEL JFET,5434	TG-179
Q41,42,45,47	TRANS,NPN CATV SILICON,MPSH17	TG-221
Q49,50	TRANS,N CHANNEL JFET,5432 (TO-92)	TG-198
Q8,9	TRANS,P CHANNEL JFET,J270 (TO-92)	TG-166
R101	RES,12.4K,1%,1/8W,METAL FILM	R-88-12.4K
R102	RES,820K,5%,1/4W,COMPOSITION OR FILM	R-76-820K
R103,106,109	RES,180K,5%,1/4W,COMPOSITION OR FILM	R-76-180K
R104	RES,91K,5%,1/4W,COMPOSITION OR FILM	R-76-91K
R107	RES,1.5M,5%,1/4W,COMPOSITION OR FILM	R-76-1.5M
R110	RES,300K,5%,1/4W,COMPOSITION OR FILM	R-76-300K
R115	RES,200K,5%,1/4W,COMPOSITION OR FILM	R-76-200K
R119	RES,4.99K,1%,1/8W,METAL FILM	R-88-4.99K
R12	RES,10G,2%,1.5W,HY MEG	R-289-10G
R124	RES,2.4K,5%,1/4W,COMPOSITION OR FILM	R-76-2.4K
R125	RES,75K,1%,1/8W,METAL FILM	R-88-75K
R126,137,190	RES,100,1%,1/8W,METAL FILM	R-88-100
R128	RES,681..1%,1/10W,METAL FILM	R-263-681
R129..131	RES,732K,1%,1/4W,PRECISION THIN FILM	R-368-732K
R13,29,74,75, 153,155,188,189	RES,10K,.1%,1/10W, METAL FILM	R-263-10K
R132	RES,51K,5%,1/4W,COMPOSITION OR FILM	R-76-51K
R134,135	RES,100K,10%,1/2W,COMPOSITION	R-1-100K
R138	RES,22K,10%,1/2W,COMPOSITION	R-1-22K
R139..146	RES,794,.1%,1/10W,METAL FILM	R-263-794



R14	RES, 13.82K, .1%,1/8W,METAL FILM	R-377-13.82K
R147	RES,2734K,.1%,1/8W,METAL FILM	R-377-27.4K
R15	RES,300K,.1%,1/8W,METAL FILM	R-377-300K
R150	RES,5.1K,5%,1/4W,COMPOSITION OR FILM	R-76-5.1K
R152,154	RES,1.8M,5%,1/4W,COMPOSITION OR FILM	R-76-1.8M
R156	RES,137K,1%,1/8W,METAL FILM	R-88-137K
R16..18	RES,1M,0.1%,1/4W,METAL FILM	R-374-1M
R160,161	RES,10K,10%,1/2W,COMPOSITION	R-1-10K
R163	RES,2K,5%,1/4,COMPOSITION OR FILM	R-76-2K
R164,165	RES,3.9K,5%,1/4W,COMPOSITION OR FILM	R-76-3.9K
R166	RES,51K,5%,1/4W,COMPOSITION OR FILM	R-76-51K
R167	RES,56.2K,1%,1/8W,METAL FILM	R-88-56.2K
R169	RES,510,5%,1/4W,COMPOSITION OR FILM	R-76-510
R170	RES,250,.1%,1/10W,WIRE WOUND	R-291-250
R175	RES,1M,5%,1/4W, COMPOSITION OR FILM	R-76-1M
R177..184, R199..201	RESISTOR	R-385-10.92
R185	RES,10M,5%,1/4W,COMPOSITION OR FILM	R-76-10M
R191	RES,182K,1%,1/8W,METAL FILM	R-88-182K
R2	RES,10K,10%,1W,COMPOSITION	R-2-10K
R20,22	RES,13K,5%,1/4W,COMPOSITION OR FILM	R-76-13K
R25,32..35,49, 81,174	RES,560K,5%,1/4W,COMPOSITION OR FILM	R-76-560K
R26,192,194	RES,100K,.1%,1/10W,METAL FILM	R-263-100K
R27,30,171..173	SELECTED RESISTOR SET	238-600
R28	RES,49.9,1%,1/8W,COMPOSITION OR	R-88-49.9
R3,21,23,24,133	RES,10.101K,.1%,75W,WIREWOUND	R-384-10.101K
R31,100,114, 127,159,168, 196..198	RES,100K,5%,1/4W,COMPOSITION OR FILM	R-76-100K
R38	RES,998K,.1%,1/4W,METAL FILM	R-264-998K
R39	RES,9.88M,0.5%,1/2W,1200V,METAL OR FILM	R-265-9.88M
R4	RES,5.6K,5%,1/4W,COMPOSITION OR FILM	R-76-5.6K
R40	RES,1G,2%,1.5W,HY MEG	R-289-1G
R41	RES,100M,1%,1.5W,HY MEG	R-289-100M
R43,54,83,84, 148,149	RES,10K,1%,1/8W,METAL FILM	R-88-10K
R44,187	RES,90K,.1%,1/8W,METAL FILM	R-377-90K
R45,56,57,72, 73,79,80,186	RES,10K,.1%,1/8W,METAL FILM	R-377-10K
R46	RES,15K,5%,1/4W,COMPOSITION OR FILM	R-76-15K
R47,48,116..118, 120..122,136, 176,195	RES,10K,5%,1/4W,COMPOSITION OR FILM	R-76-10K
R5,6	RES,1K,5%,1/4W,COMPOSITION OR FILM	R-76-1K
R50,52,53,66, 71,105,108	RES,20K,5%,1/4W,COMPOSITION OR FILM	R-76-20K
R51	RES,243K,5%,1/4W,COMPOSITION OR	R-88-243K
R55,82	RES,150,5%,1/4W, COMPOSITION OR FILM	R-76-150
R58,67	RES,1.1M,5%,1/4W,COMPOSITION OR FILM	R-76-1.1M
R7	RES,51,5%,1/4W,COMPOSITION OR FILM	R-76-51
R76	RES,237,1%,1/8W,METAL FILM	R-88-237
R77	RES,4.5K,.1%,1/10W,METAL FILM	R-263-4.5K
R78	RES,7.39K,.1%,1/10W,METAL FILM	R-263-7.39K



R8,157	RES,49.9K,1%,1/8W,METAL FILM	R-88-49.9K
R85,151	RES,19.6K,1%,1/8W,METAL FILM	R-88-19.6K
R86,87	RES,100K,.1%,1/8W,METAL FILM	R-377-100K
R89,193	RES,11.1K,.1%,1/8W,METAL FILM	R-377-11.1K
R9,42,68,123, 162	RES,1K,5%,1/4W,COMPOSITION OR FILM	R-76-1K
R92,94	RES,2.2K,5%,1/4W,COMPOSITION OR FILM	R-76-2.2K
R93,95	RES,3.57K,5%,1/4W,COMPOSITION OR	R-88-3.57K
R96	RES,1.24K,1%,1/8W,METAL FILM	R-88-1.24K
R97	RES,82K,5%,1/4W,COMPOSITION OR FILM	R-76-82K
R98	RES,18K,5%,1/4W,COMPOSITION OR FILM	R-76-18K
TE2,3,6..8,10, 12,14,16..19, 22..29	TERMINAL (TEFLON)	TE-97-1
TE20,21	TEFLON TERMINAL	TE-111
U1,45,48,50	IC,SPST CMOS ANALOG SWITCH,DG211	IC-320
U10,31,52	IC,QUAD COMPARATOR,LM339	IC-219
U11	IC,WIDEBAND CURRENT BUFFER,LH4001	IC-572
U18	IC,22V OP-AMP,OP-07	IC-207
U19,47	IC,20V OP-AMP,LT1055CN8	IC-672
U2,3	IC,OP-AMP,OPA128 IC-542	
U23,25	IC,14-BIT CMOS D/A CONVERT,AD7538KN	IC-601
U26,28,29,35, 41..43,53	IC,8 STAGE SHIFT/STORE REGISTER,4094	IC-251
U30	IC,QUAD 2-1 LINE DATA SELEC/MULT,74HC158	IC-587
U32	IC,QUAD LOW POWER JFET,LF444	IC-329
U33	IC,QUAD 2 INPUT POS AND,74HC08	IC-465
U34	IC,DUAL D-TYPE FLIP FLOP,74HC74	IC-337
U37	IC,DARLINGTON ARRAY,2003	IC-206
U38	IC,3 TO8 LINE DECODER/DEMULTI,74HC138	IC-431
U4,8,13,14,17	IC,18V BIFET OP-AMP,AD744	IC-586
U44	IC,RETRIG MONO MULTIVIB,74HC123	IC-492
U46	IC,OCTAL BUFFER,74HC244N	IC-469
U49	IC,SPST CMOS ANALOG SWITCH,DG271	IC-508
U5,7,21,22,24	IC,15V OP-AMP, 1007	IC-422
U51	IC,LOW-PWR BIFET OPAMP,AD648	IC-719
U6	IC,CMOS SERIAL INPUT 12-BIT DAC,MP7543	IC-419
U9,12,15	IC,DUAL HIGH SPEED OP-AMP,LT1057ACN8	IC-590
VR1,6	DIODE,ZENER 15V,1N4744A (TO-41)	DZ-75
VR11	DIODE,ZENER 6.4V,IN4579 (DO-7)	DZ-73
VR14,15	DIODE,ZENER 200V,1N5388A (CASE 17)	DZ-74
VR2,5	DIODE,ZENER 4.3V,1N749A (DO-7)	DZ-63
VR3,4	DIODE,ZENER, 12V,IN9638	DZ-54
VR9,10	DIODE,ZENER 15V,1N718 (DO-7)	DZ-18

**TABLE 2. MODEL 238 DIGITAL BOARD, PARTS LIST**

<b>CIRCUIT DESIG.</b>	<b>DESCRIPTION</b>	<b>KEITHLEY PART NO.</b>
AT1..3,7,8	IC,DUAL HIGH CMR/SPEED OPTO,HCPL-2631	IC-588
AT5	IC,OPTPCOUPLER,2601	IC-239
AT6	IC,OPTOCOUPLER,HCPL-2400	IC-464
BT1	BATTERY, LITHIUM BATTERY HOLDER	BA-44 BH-34
C1	CAP,33PF,10%,1000V,CERAMIC	C-64-33P
C10,118	CAP,10,000UF,20%,35V,ALUM ELEC	C-433-10000
C106,107	CAP,.1UF,20%,50V,CERAMIC	C-237-.1
C108,109	CAP,.02,20%,.500V CERAMIC	C-22-.02
C110,119	CAP,.1UF,20%,100V EPOXY	C-416-.1
C116	CAP,710PF,2%,50V,CERAMIC	C-348-710P
C120	CAP,.01UF,20%,50V,CERAMIC	C-365-.01
C121..146	CAP,.01UF,20%,50V,CERAMIC	C-365-.01
C147..176	CAP,.1UF,20%,50V,CERAMIC	C-365-.1
C15..17,24,33,94	CAP, 10UF,-20+100%,25V,ALUM ELEC	C-314-10
C4	CAP,10000UF,-20+30%,25V,ALUM ELEC	C-342-10000
C52,54	CAP,100UF,20%,63V,ALUM ELEC	C-403-100
C53,55	CAP,1000UF,-10+100%,35V,ELECTROLYTIC	C-309-1000
C56,57	CAP,100UF,-10+100%,35V,ALUM ELEC	C-295-100
C58,59	CAP,560UF,20%,200V,ALUM ELEC	C-355-560
C63	CAP,.0047UF,10%,100V,POLYPROPYLENE	C-306-.0047
C64	CAP,820PF,10%,1000V,CERAMIC	C-64-820P
C67	CAP,22PF,10%,1000V,CERAMIC	C-64-22P
C68,70,72	CAP,47PF,10%,1000V,CERAMIC	C-64-47P
C7	CAP,4700UF,-20+100%,16V,ALUMINUM	C-313-4700
C71	CAP,22PF,20%,500V,CERAMIC	C-22-22P
C73,89..93, 95..97	CAP,1UF,20%,50V, CERAMIC	C-237-1
CR1	DIODE, BRIDGE PE05	RF-48
CR12	DIODE,BRIDGE,KBU4B (CASE KBU)	RF-64
CR13..16,19,20, 23..26	DIODE,SILICON,IN4148 (DO-35)	RF-28
CR2,3,6,7	DIODE,SWITCHING,IN4607 (DO-35)	RF-41-1
CR27	DIODE,SILICON,SCHOTTKY,SB120	RF-78
CR4,5	DIODE,BRIDGE,VM18	RF-52
CR8..11	DIODE,SILICON,IN4006 (D0-41)	RF-38
F1	FUSE, 1.25A,250V FUSE HOLDER FUSE CARRIER	FU-28 FH-21 FH-25
J10	CONN,RIGHT ANGLE,24PIN	CS-507
J16,23	MODIFIED, CONNECTOR	590-314-4
J18	MODIFIED, CONNECTOR	590-314-10
J20	MODIFIED CONNECTOR	236-329A
J22	MODIFIED, CONNECTOR	590-314-3
J8	CONN, MALE, 3 PIN	CS-288-3
L1	CHOKE, 1-UH	CH-16

P19	CABLE ASSEMBLY	CA-27-12C
Q2	TRANS,N-CHANNEL FET,TN06L	TG-216
Q3	TRANS, N CHANNEL JFET,PN5434(TO-92)	TG-174-1
Q4	TRANS,N CHANNEL DUAL FET,MP842 (T0-52)	TG-175
Q5	TRANS,NPN SILICON,2N3904 (T0-92)	TG-47
Q6	TRANS,N CHANNEL FET,2N4392 (TO-92)	TG-128-1
Q7	TRANS,TRIODE THYRISTOR,MAC223-6	TG-172
R1	RES,430,5%,1/4W,COMPOSITION OR FILM	R-76-430
R15,17,50,80,87,90,91	RES,1K,5%,1/4W,COMPOSITION OR FILM	R-76-1K
R16,23	RES NET,3.3K,5%,1.25W	TF-140
R2	RES,330,5%,1/4W,COMPOSITION OR FILM	R-76-330
R20..22,71,81	RES,100,5%,1/4W,COMPOSITION OR FILM	R-76-100
R25,72,77	RES,3.3K,5%,1/4W, COMPOSITION OR FILM	R-76-3.3K
R3,4,10,11,28,83..86,89	RES,470,5%,1/4W,COMPOSITION OR FILM	R-76-470
R32	RES,560K,5%,1/4W,COMPOSITION OR FILM	R-76-560K
R33	RES,6.2K,5%,1/4W COMPOSITION OR FILM	R-76-6.2K
R34	RES,2K,5%,1/4,COMPOSITION OR FILM	R-76-2K
R35,75,76	RES,47K,5%,1/4W,COMPOSITION OR FILM	R-76-47K
R36	RES,100,1%,1/8W,METAL FILM	R-88-100
R37	RES,4.87K,1%,1/8W,METAL FILM	R-88-4.87K
R38,39,59..62,65	RES,10K,5%,1/4W,COMPOSITION OR FILM	R-76-10K
R41	RES,142.2K,.02%,1/8W,PRECISION THIN FILM	R-365-142.2K
R42	RES,100K,5%,1/4W,COMPOSITION OR FILM	R-76-100K
R43	POT,10K,10%,.5W,NON-WIREWOUND	RP-97-10K
R44,47	RES,200,5%,1/4W,COMPOSITION OR FILM	R-76-200
R45,48	RES,20K,1%,1/8W,METAL FILM	R-88-20K
R46	RES,32.4K,1%,1/8W,METAL FILM	R-88-32.4K
R49,52	RES,7.87K,1%,1/8W,METAL FILM	R-88-7.87K
R51	RES,2.15K,1%,1/8W,METAL FILM	R-88-2.15K
R53	RES,15.4K,1%,1/8W,METAL FILM	R-88-15.4K
R54	RES,10K,1%,1/8W,METAL FILM	R-88-10K
R55	RES,7.78K,.02%,1/8W,PRECISION THIN FILM	R-365-7.78K
R56	RES,1M,5%,1/4W, COMPOSITION OR FILM	R-76-1M
R57	RES,15K,5%,1/4W,COMPOSITION OR FILM	R-76-15K
R58	RES,5.1K,5%,1/4W,COMPOSITION OR FILM	R-76-5.1K
R6,8	RES,5.62K,1%,1/8W,METAL FILM	R-88-5.62K
R63	RES,51.1K,1%,1/8W,METAL FILM	R-88-51.1K
R64	RES,26.7K,1%,1/8W,METAL FILM	R-88-26.7K
R7,R9	RES,243,1%,1/8W,METAL FILM	R-88-243
R70	RES,996K,.1%,1/4W,METAL FILM	R-264-996K
R73,74	RES,15K,10%,2W,COMPOSITION	R-3-15K
R78,79	RES,4.3K,5%,1/4W,COMPOSITION OR FILM	R-76-4.3K
R82	RES NET,1K,2%,1.70W	TF-180-3
R92	RES,510,5%,1/4W,COMPOSITION OR FILM	R-76-510
R93	RES,270,5%,1/4W,COMPOSITION OR FILM	R-76-270
R94,95	RES,5.6K,5%,1/4W,COMPOSITION OR FILM	R-76-5.6K
S1	SWITCH,PUSHBUTTON (6 POLE)	SW-466
S2	SWITCH,SLIDE (DPDT)	SW-476
S3	SWITCH,PUSHBUTTON (2 POLE)	SW-469
T1	TR-277B (JAPAN) TRANSFORMER, ASSY	TR-276

TP1,2	CONN,TEST POINT	CS-553
U1	IC,PAL,20L10	IC-643
U12	IC,CMOS DUAL PORT RAM,IDT7130	LSI-88
U13,30	IC,32KX8 STATIC CMOS RAM,D43256C-15L	LSI-76
U14,28	IC,VERSATILE INTERFACE ADAPTER,G65SC22	LSI-86
U15,25	IC,8 BIT MICROPROCESSING UNIT,MC68B09	LSI-65
U16	IC,10 INPUT AND-OR-INVERT ARRAY,PAL16L8	IC-582
U17	EPROM PROGRAM	238-800-**
U18,19,58	IC,12 STAGE BINARY COUNTER,74HC4040	IC-407
U21,40,46	IC,DUAL 4 BIT COUNTER,74HCT393	IC-462
U23	IC,HEX INVERTER,74HC05	IC-466
U26	IC,10 INPUT AND-OR-INVERT ARRAY,PAL16L8	IC-682
U27	IC,GPIB ADAPTER,9914A	LSI-49
U29	IC,NONVOLATILE CONTROLLER DS1210	IC-541
U31	EPROM PROGRAM	238-801-**
U32,47	IC,QUAD 2 INPUT NOR,74HC02	IC-412
U33	IC,PROGRAMMABLE E2ROM 2816B	LSI-83
U34	IC,OCTAL INTERFACE BUS,75160	IC-298
U35	IC,OCTAL INTERFACE BUS TRANSCEIVER,75161	IC-299
U36	IC,SUPPLY VOLTAGE SUPERVISOR,TL7705AC	IC-602
U38	IC,OCTAL BUFFER,74HC244N	IC-469
U39	IC, 3 TO8 LINE DECODER/DEMULTI,74HC138	IC-431
U41	IC,DUAL 4 BIT DECADE COUNTER,74HC390	IC-500
U42,44	IC,8 STAGE SHIFT/STORE REGISTER,4094	IC-251
U43,52	IC,TRIPLE 2 CH MULTI/DEMUX,4053	IC-283-1
U45	IC,8 BIT IDENTITY COMP,74HC688	IC-488
U48	IC,QUAD COMPARATOR,LM339	IC-219
U49,55	IC,DUAL D-TYPE FLIP FLOP,74HC74	IC-337
U50	IC,DUAL LOW NOISE OP-AMP,5534	IC-540
U51,57,59	IC,HEX INVERTER,74HC04	IC-354
U54	IC,QUAD 2 INPUT NAND,74HC00	IC-351
U56	IC,DUAL LOW NOISE OP-AMP,NE5532	IC-501
	USE ON TR WIRING CABLE TIE	CC-38-2
VR1	IC,+5V REGULATOR,20MA,LM323	IC-240
	HEAT SINK	HS-22
VR2	RIVET, 1/8 DIA. X 3/16 LG (1) STAKING, HS-25	32469-2
VR3	RIVET, 1/8 DIA. X 3/16 LG (1) STAKING, HS-25	32469-5
VR4	RIVET, 1/8 DIA. X 3/16 LG (1) STAKING, HS-25	32469-6
VR5	IC,VOLTAGE REGULATOR,LM317MP	IC-308
VR6	IC,VOLTAGE REGULATOR,LM337MP	IC-309
VR7,8	DIODE,ZENER 15V,1N4744A (TO-41)	DZ-75
VR9, 10	DIODE, ZENER 100V, IN5378B	DZ-72-2
Y1	OSCILLATOR, 8MHZ	CR-25-4
Y2	CRYSTAL, 7.68MHZ	CR-29

\*\*ORDER CURRENTLY INSTALLED FIRMWARE LEVEL. FOR EXAMPLE, IF THE FIRMWARE REVISION LEVEL IS A06, ORDER PART NUMBER 238-800-A06 AND 238-801-A06.

**TABLE 3. MODEL 238 DISPLAY BOARD, PARTS LIST**

<b>CIRCUIT DESIG.</b>	<b>DESCRIPTION</b>	<b>KEITHLEY PART NO.</b>
C1..4 C5	CAP,.01UF,20%,50V,CERAMIC CAP, 10UF,-20+100%,25V,ALUM ELEC	C-365-.01 C-314-10
CR1..10	DIODE,SILICON,IN4148 (DO-35)	RF-28
DS1..9 DS10..28	DIGITAL DISPLAY PILOT LIGHT,RED,LED LED MOUNTS	DD-39 PL-71 MK-22-1
P24	CABLE ASSEMBLY, 20 CONDUCTOR	CA-27-9
R1..23,25,27, 29..31.33.34 R24 R26 R28,32	RES,82,5%,1/4W,COMPOSITION OR FILM RES, 15, 5%, 1/4 COMPOSITION OR FILM RES, 15, 5%, 1/4 COMPOSITION OR FILM RES,3.3K,5%,1/4W, COMPOSITION OR FILM	R-76-82 R-76-15 R-76-15 R-76-3.3K
S1 S2..34	DIGITAL CONTACTING ENCODER SWITCH, MOMENTARY	SW-472 SW-435
U1 U2 U3 U4,7,8 U5,6,9,10	IC,QUAD 2 INPUT NOR,74HC02 IC,12 STAGE BINARY COUNTER,74HC4040 1 OF 10 DECODER, 74HC42 IC,8-CHANNEL SAT SINK DRIVER,UDN-2596A IC,8-BIT SERIAL-INPUT,UNC5895A	IC-412 IC-407 IC-583 IC-578 IC-537

**TABLE 4. MODEL 238 OUTPUT MODULE, PARTS LIST**

<b>CIRCUIT DESIG.</b>	<b>DESCRIPTION</b>	<b>KEITHLEY PART NO.</b>
C10,12	CAP,3300PF,5%,500V,DIPPED MICA	C-236-3300P
C17,19	CAP,.01UF,10%,1000V,CERAMIC	C-64-.01
C20	CAP,.01UF,20%,50V,CERAMIC	C-365-.01
C21,30	CAP,1UF,20%,50V, CERAMIC	C-237-1
C22,23	CAP,1800PF,1%,500V,MICA	C-209-1800P
C24,25	CAP,3300PF,10%,100V,CERMANIC	C-430-3300P
C26,28	CAP,2200PF,1%,500V,MICA	C-278-2200P
C27,29	CAP,6800PF,1%,100V,MICA	C-248-6800P
CR18,26	DIODE,SWITCHING,IN4149 (DO-35)	RF-60
CR19,27	DIODE,1N5404	RF-74
CR20,21	DIODE,SCHOTTKY, IN5711	RF-69
CR7,9	DIODE,SILICON,IN4148 (DO-35)	RF-28
CR8,10..12,17, 22..25	DIODE,SILICON,1N4937	RF-71
K1	RELAY,HIGH SENSITIVITY,18W-K	RL-140
P16,23	HOUSING, CONNECTOR	CS-287-4
Q1,2	TRANS,N CHAN MOSPOW FET,2N7000 (TO-92)	TG-195
Q18,23	TRANS,N-CHANNEL FET,IRF630	TG-214
Q19,25	TRANS,PNP POWER,MJE350	TG-210
Q21,24	TRANS,NPN SILICON,MJE340	TG-209
Q27	TRANS,PNP SILICON 2N3906 (TO-92)	TG-84
Q34,40	TRANS,P-FIELD EFFECT,MTP20P06	TG-229
Q35	TRANS,PNP POWER TRANS, TIP106(TO 220)	TG-231
Q36	TRANS,P-CHANNEL DMOSFET,VP0104N3(TO-92)	TG-193
Q37	TRANS,PNP POWER TRANS,MJE250(TO-220)	TG-186
Q38	TRANS,NPN POWER TRANS, TIP101(TO 220)	TG-230
Q39,44,45,47	TRANS,NPN COMP SILICON AMP,2N5089	TG-62-1
Q41	TRANS,N-CHANNEL DMOSFET,VN0101NS(TO-92)	TG-192
Q42	TRANS,NPN POWER TRANS,MJE240(TO-220)	TG-185
Q43,46	TRANS,N-FIELD EFFECT,MTP20N08	TG-228
Q7,8	TRANS,P-CHANNEL 200V FET,IRF9630	TG-215
Q9,20,22,26,28	TRANS,NPN SILICON,2N3904 (TO-92)	TG-47
R1,2	RES,158,1%,1/8W,METAL FILM	R-88-158
R18,19	RES,1.1M,5%,1/4W,COMPOSITION OR FILM	R-76-1.1M
R20,34,36,39	RES,3.3M,5%,1/4W,COMPOSITION OR FILM	R-76-3.3M
R21..23,28,37, 38,47,50,55,60, 63,65	RES,51,5%,1/4W,COMPOSITION OR FILM	R-76-51
R24,26	RES,26.1,1%,1/8W,METAL FILM	R-88-26.1
R25,27	RES,619,1%,1/8W,METAL FILM	R-88-619
R29,30	RES,27.4,1%,1/8W,METAL FILM	R-88-27.4
R31,32	RES,11.3K,1%,1/8W,METAL FILM	R-88-11.3K
R45,46	RES,1M,5%,1/4W, COMPOSITION OR FILM	R-76-1M
R48,51	RES,10K,5%,1/4W,COMPOSITION OR FILM	R-76-10K
R49,52	RES,.51,5%,1W,COMPOSITION OR FILM	R-357-.51
R53,54	RES,2.2M,5%,1/4W,COMPOSITION OR FILM	R-76-2.2M
R56,58	RES,1.8M,5%,1/4W,COMPOSITION OR FILM	R-76-1.8M

R57,59	RES,100K,5%,1/4W,COMPOSITION OR FILM	R-76-100K
R61,64	RES,1.5M,5%,1/4W,COMPOSITION OR FILM	R-76-1.5M
R62,66	RES, 680K, 5%,1/4W, COMPOSITION OR FILM	R-76-680K
R67,68	RES,470,5%,1/4W,COMPOSITION OR FILM	R-76-470
	TX-17x1/4x1 1/2 P15 CONNECTOR, HOUSING	CS-638-15
VR1,2	DIODE,ZENER 6.44V,IN4577AGED (DO-7)	DZ-58



**TABLE 5. MODEL 238 MISCELLANEOUS, PARTS LIST**

<b>CIRCUIT DESIG.</b>	<b>DESCRIPTION</b>	<b>KEITHLEY PART NO.</b>
	OVERLAY, FRONT PANEL	238-302
	LINE CORD	CO-7
	PUSHBUTTON	228-317-4
	PUSHBUTTON	228-317-5
	PUSHBUTTON	228-317-6
	PUSHBUTTON	228-317-7
	REAR FOOT	FE-21
	MOUNTING RAILS	228-319
	FRONT PANEL	236-304
	KNOB	236-305
	A/D SHIELD	236-311
	OUTPUT SHROUD	236-312
	WINDOW (RED)	236-314-1
	BOTTOM SHIELD	236-315
	INNER SHIELD	236-316
	TOP SHIELD, ANALOG BOARD	236-317
	BOTTOM SHIELD INSULATOR	236-323
	FILTER SHROUD	236-332
	REAR PANEL	236-309
	POWER SUPPLY SHIELD	238-306
	SUPPORT, PRINTED CIRCUIT BOARD	228-318
	CABLE ASSY 3 LUG TRIAX	CA-63-10
	MODIFIED, PRINTED CIRCUIT SUPPORT	228-314-2
	BOTTOM SHIELD	ST-137-2
	CAP	CAP-28-1
	FILTER	FL-9
	FAN	FN-25
	CAP,100PF,10%,1000V,CERAMIC	C-64-100P
	SUPPORT, PRINTED CIRCUIT BOARD	228-318
	TRIAX CONNECTOR	CS-723
	CONNECTOR, RIGHT ANGLE SMB	CS-759
	TRIAX CONNECTOR	CS-723
	CONNECTOR, RIGHT ANGLE SMB	CS-759
	DECORATIVE STRIP ASSEMBLY	193-322
	DECORATIVE STRIP ASSEMBLY	193-323
J1,2	CABLE ASS'Y (TRIAX, RIGHT ANGLE SMB)	CA-72-2
J25,26	CONNECTOR, 3 PIN MALE	CS-659
J3	CABLE ASS'Y (TRIAX, RIGHT ANGLE SMB)	CA-72-1
J4	BINDING POST	BP-11-0
J5	BINDING POST (METAL)	BP-15
J6,7	CONNECTOR,BNC	CS-249
J9	LINE FILTER	LF-2
P20	HOUSING, CONNECTOR	CS-287-5
P22	CONNECTOR, HOUSING	CS-287-3
	FRONT FOOT ASSEMBLY	706-317
	TOP COVER	236-324
	BOTTOM COVER	228-313

# Service Form

Model No. \_\_\_\_\_ Serial No. \_\_\_\_\_ Date \_\_\_\_\_

Name and Telephone No. \_\_\_\_\_

Company \_\_\_\_\_

List all control settings, describe problem and check boxes that apply to problem. \_\_\_\_\_

- |  |  |  |
|--|--|--|
| <input type="checkbox"/> Intermittent            | <input type="checkbox"/> Analog output follows display   | <input type="checkbox"/> Particular range or function bad; specify |
| <input type="checkbox"/> IEEE failure            | <input type="checkbox"/> Obvious problem on power-up     | <input type="checkbox"/> Batteries and fuses are OK                |
| <input type="checkbox"/> Front panel operational | <input type="checkbox"/> All ranges or functions are bad | <input type="checkbox"/> Checked all cables                        |

Display or output (check one)

- |                                   |  |
|-----------------------------------|--|
| <input type="checkbox"/> Drifts   | <input type="checkbox"/> Unable to zero              |
| <input type="checkbox"/> Unstable | <input type="checkbox"/> Will not read applied input |
| <input type="checkbox"/> Overload |  |

- |   |  |
|---|--|
| <input type="checkbox"/> Calibration only | <input type="checkbox"/> Certificate of calibration required |
| <input type="checkbox"/> Data required    |  |

(attach any additional sheets as necessary)

Show a block diagram of your measurement system including all instruments connected (whether power is turned on or not). Also, describe signal source.

Where is the measurement being performed? (factory, controlled laboratory, out-of-doors, etc.)

\_\_\_\_\_

What power line voltage is used? \_\_\_\_\_ Ambient temperature? \_\_\_\_\_ °F

Relative humidity? \_\_\_\_\_ Other? \_\_\_\_\_

Any additional information. (If special modifications have been made by the user, please describe.)

\_\_\_\_\_

Be sure to include your name and phone number on this service form.