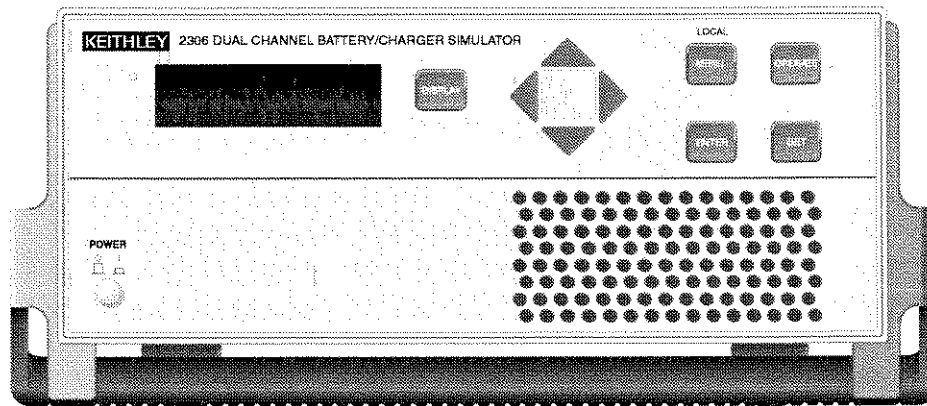


Model 2302/2306  
Battery/Charger Simulator  
Quick Results Guide



Contains Result Oriented Operating Information

**KEITHLEY**

# WARRANTY

Keithley Instruments, Inc. warrants this product to be free from defects in material and workmanship for a period of 1 year from date of shipment.

Keithley Instruments, Inc. warrants the following items for 90 days from the date of shipment: probes, cables, rechargeable batteries, diskettes, and documentation.

During the warranty period, we will, at our option, either repair or replace any product that proves to be defective.

To exercise this warranty, write or call your local Keithley representative, or contact Keithley headquarters in Cleveland, Ohio. You will be given prompt assistance and return instructions. Send the product, transportation prepaid, to the indicated service facility. Repairs will be made and the product returned, transportation prepaid. Repaired or replaced products are warranted for the balance of the original warranty period, or at least 90 days.

## LIMITATION OF WARRANTY

This warranty does not apply to defects resulting from product modification without Keithley's express written consent, or misuse of any product or part. This warranty also does not apply to fuses, software, non-rechargeable batteries, damage from battery leakage, or problems arising from normal wear or failure to follow instructions.

THIS WARRANTY IS IN LIEU OF ALL OTHER WARRANTIES, EXPRESSED OR IMPLIED, INCLUDING ANY IMPLIED WARRANTY OF MERCHANTABILITY OR FITNESS FOR A PARTICULAR USE. THE REMEDIES PROVIDED HEREIN ARE BUYER'S SOLE AND EXCLUSIVE REMEDIES.

NEITHER KEITHLEY INSTRUMENTS, INC. NOR ANY OF ITS EMPLOYEES SHALL BE LIABLE FOR ANY DIRECT, INDIRECT, SPECIAL, INCIDENTAL OR CONSEQUENTIAL DAMAGES ARISING OUT OF THE USE OF ITS INSTRUMENTS AND SOFTWARE EVEN IF KEITHLEY INSTRUMENTS, INC., HAS BEEN ADVISED IN ADVANCE OF THE POSSIBILITY OF SUCH DAMAGES. SUCH EXCLUDED DAMAGES SHALL INCLUDE, BUT ARE NOT LIMITED TO: COSTS OF REMOVAL AND INSTALLATION, LOSSES SUSTAINED AS THE RESULT OF INJURY TO ANY PERSON, OR DAMAGE TO PROPERTY.

# KEITHLEY

Keithley Instruments, Inc. • 28775 Aurora Road • Cleveland, OH 44139 • 440-248-0400 • Fax: 440-248-6168 • <http://www.keithley.com>

BELGIUM:	Keithley Instruments B.V.	Bergensesteenweg 709 • B-1600 Sint-Pieters-Leeuw • 02/363 00 40 • Fax: 02/363 00 64
CHINA:	Keithley Instruments China	Yuan Chen Xin Building, Room 705 • 12 Yumin Road, Dewai, Madian • Beijing 100029 • 8610-62022886 • Fax: 8610-62022892
FRANCE:	Keithley Instruments Sarl	B.P. 60 • 3, allée des Garays • 91122 Palaiseau Cédex • 01 64 53 20 20 • Fax: 01 60 11 77 26
GERMANY:	Keithley Instruments GmbH	Landsberger Strasse 65 • D-82110 Germering • 089/84 93 07-40 • Fax: 089/84 93 07-34
GREAT BRITAIN:	Keithley Instruments Ltd	The Minster • 58 Portman Road • Reading, Berkshire RG30 1EA • 0118-9 57 56 66 • Fax: 0118-9 59 64 69
INDIA:	Keithley Instruments GmbH	Flat 2B, WILOCRISSA • 14, Rest House Crescent • Bangalore 560 001 • 91-80-509-1320/21 • Fax: 91-80-509-1322
ITALY:	Keithley Instruments s.r.l.	Viale S. Gimignano, 38 • 20146 Milano • 02/48 30 30 08 • Fax: 02/48 30 22 74
NETHERLANDS:	Keithley Instruments B.V.	Postbus 559 • 4200 AN Gorinchem • 0183-635333 • Fax: 0183-630821
SWITZERLAND:	Keithley Instruments SA	Kriesbachstrasse 4 • 8600 Dübendorf • 01-821 94 44 • Fax: 01-820 30 81
TAIWAN:	Keithley Instruments Taiwan	1 Fl. 85 Po Ai Street • Hsinchu, Taiwan, R.O.C. • 886-3572-9077 • Fax: 886-3572-9031

10/99

---

# Model 2302/2306 Battery/Charger Simulator Quick Results Guide

©1999, Keithley Instruments, Inc.  
All rights reserved.  
Cleveland, Ohio, U.S.A.  
First Printing, March 1999  
Document Number: 2306-903-01 Rev. A

---

## Manual Print History

The print history shown below lists the printing dates of all Revisions and Addenda created for this manual. The Revision Level letter increases alphabetically as the manual undergoes subsequent updates. Addenda, which are released between Revisions, contain important change information that the user should incorporate immediately into the manual. Addenda are numbered sequentially. When a new Revision is created, all Addenda associated with the previous Revision of the manual are incorporated into the new Revision of the manual. Each new Revision includes a revised copy of this print history page.

Revision A (Document Number 2306-903-01) ..... March 1999

All Keithley product names are trademarks or registered trademarks of Keithley Instruments, Inc.  
Other brand names are trademarks or registered trademarks of their respective holders.



---

## Safety Precautions

The following safety precautions should be observed before using this product and any associated instrumentation. Although some instruments and accessories would normally be used with non-hazardous voltages, there are situations where hazardous conditions may be present.

This product is intended for use by qualified personnel who recognize shock hazards and are familiar with the safety precautions required to avoid possible injury. Read the operating information carefully before using the product.

The types of product users are:

**Responsible body** is the individual or group responsible for the use and maintenance of equipment, for ensuring that the equipment is operated within its specifications and operating limits, and for ensuring that operators are adequately trained.

**Operators** use the product for its intended function. They must be trained in electrical safety procedures and proper use of the instrument. They must be protected from electric shock and contact with hazardous live circuits.

**Maintenance personnel** perform routine procedures on the product to keep it operating, for example, setting the line voltage or replacing consumable materials. Maintenance procedures are described in the manual. The procedures explicitly state if the operator may perform them. Otherwise, they should be performed only by service personnel.

**Service personnel** are trained to work on live circuits, and perform safe installations and repairs of products. Only properly trained service personnel may perform installation and service procedures.

Exercise extreme caution when a shock hazard is present. Lethal voltage may be present on cable connector jacks or test fixtures. The American National Standards Institute (ANSI) states that a shock hazard exists when voltage levels greater than 30V RMS, 42.4V peak, or 60VDC are present. **A good safety practice is to expect that hazardous voltage is present in any unknown circuit before measuring.**

Users of this product must be protected from electric shock at all times. The responsible body must ensure that users are prevented access and/or insulated from every connection point. In some cases, connections must be exposed to potential human contact. Product users in these circumstances must be trained to protect themselves from the risk of electric shock. If the circuit is capable of operating at or above 1000 volts, **no conductive part of the circuit may be exposed.**

As described in the International Electrotechnical Commission (IEC) Standard IEC 664, digital multi-meter measuring circuits (e.g., Keithley Models 175A, 199, 2000, 2001, 2002, and 2010) are Installation Category II. All other instruments' signal terminals are Installation Category I and must not be connected to mains.

Do not connect switching cards directly to unlimited power circuits. They are intended to be used with impedance limited sources. **NEVER** connect switching cards directly to AC mains. When connecting sources to switching cards, install protective devices to limit fault current and voltage to the card.

Before operating an instrument, make sure the line cord is connected to a properly grounded power receptacle. Inspect the connecting cables, test leads, and jumpers for possible wear, cracks, or breaks before each use.

For maximum safety, do not touch the product, test cables, or any other instruments while power is applied to the circuit under test. **ALWAYS** remove power from the entire test system and discharge any capacitors before: connecting or disconnecting cables or jumpers, installing or removing switching cards, or making internal changes, such as installing or removing jumpers.

---

Do not touch any object that could provide a current path to the common side of the circuit under test or power line (earth) ground. Always make measurements with dry hands while standing on a dry, insulated surface capable of withstanding the voltage being measured.


The instrument and accessories must be used in accordance with its specifications and operating instructions or the safety of the equipment may be impaired.


Do not exceed the maximum signal levels of the instruments and accessories, as defined in the specifications and operating information, and as shown on the instrument or test fixture panels, or switching card.


When fuses are used in a product, replace with same type and rating for continued protection against fire hazard.

Chassis connections must only be used as shield connections for measuring circuits, NOT as safety earth ground connections.

If you are using a test fixture, keep the lid closed while power is applied to the device under test. Safe operation requires the use of a lid interlock.

If a  screw is present, connect it to safety earth ground using the wire recommended in the user documentation.

The  symbol on an instrument indicates that the user should refer to the operating instructions located in the manual.

The  symbol on an instrument shows that it can source or measure 1000 volts or more, including the combined effect of normal and common mode voltages. Use standard safety precautions to avoid personal contact with these voltages.

The **WARNING** heading in a manual explains dangers that might result in personal injury or death. Always read the associated information very carefully before performing the indicated procedure.

The **CAUTION** heading in a manual explains hazards that could damage the instrument. Such damage may invalidate the warranty.

Instrumentation and accessories shall not be connected to humans.

Before performing any maintenance, disconnect the line cord and all test cables.

To maintain protection from electric shock and fire, replacement components in mains circuits, including the power transformer, test leads, and input jacks, must be purchased from Keithley Instruments. Standard fuses, with applicable national safety approvals, may be used if the rating and type are the same. Other components that are not safety related may be purchased from other suppliers as long as they are equivalent to the original component. (Note that selected parts should be purchased only through Keithley Instruments to maintain accuracy and functionality of the product.) If you are unsure about the applicability of a replacement component, call a Keithley Instruments office for information.

To clean an instrument, use a damp cloth or mild, water based cleaner. Clean the exterior of the instrument only. Do not apply cleaner directly to the instrument or allow liquids to enter or spill on the instrument. Products that consist of a circuit board with no case or chassis (e.g., data acquisition board for installation into a computer) should never require cleaning if handled according to instructions. If the board becomes contaminated and operation is affected, the board should be returned to the factory for proper cleaning/servicing.

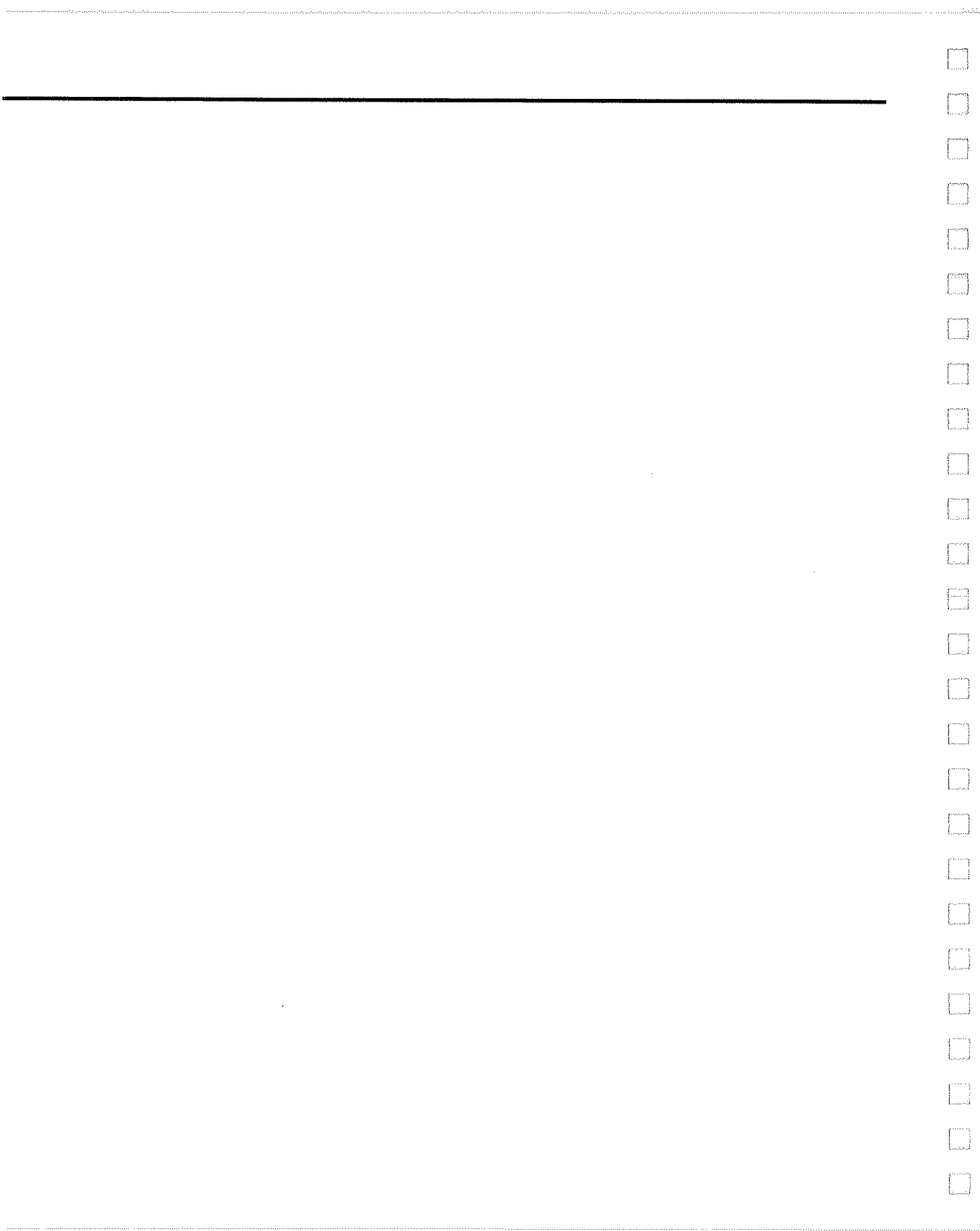
---

## Table of Contents

Introduction .....	2
Performance features .....	2
Proper connection of the supply to the DUT .....	2
Front panel operation .....	4
Menu controls .....	4
Setting the output voltage, current range, and current limit .....	4
Turning supply output ON/OFF .....	5
Actual V and I mode .....	5
DVM input mode .....	7
Pulse current mode .....	8
Long integration mode .....	15
Advanced features .....	19
Simulating battery impedance .....	19
Variable output bandwidth .....	26

## List of Illustrations

Model 2306 front panel .....	1
Rear panel view of Model 2306 .....	3
4-wire remote sense connection of the DUT to the output .....	3
2-wire local sense connection of the DUT to the output .....	4
Pulsed waveform .....	9
Eliminating the effect of a current transient on a pulse current measurement .....	10
Circuit — determining the dynamic voltage and current characteristics of a DUT .....	13
Pulsed waveform .....	16
Battery schematic .....	20
Actual battery pack terminal voltage during GSM phone simulation .....	21
Simulated GSM phone current profile .....	22
Electronic resistance of NiCd, NiMH, and Li ion battery packs .....	23
Effect of variable output impedance control .....	24
Voltage drop sample (with supplied Li ion battery pack) .....	25
Voltage drop sample (with Model 2306 and output impedance set at 0.24Ω) .....	26





# Model 2306

## Quick Results Guide

---

### NOTES

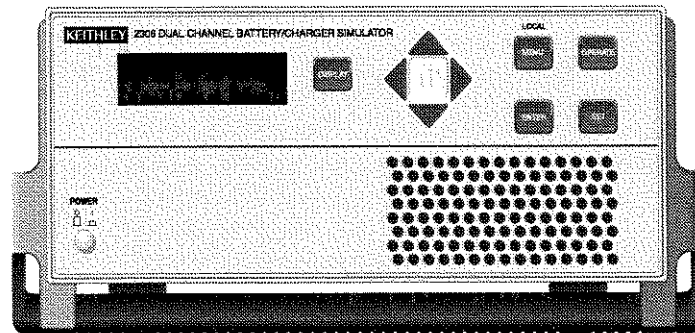
*This guide covers Keithley Models 2302 and 2306 simulators (power supplies). Since the Model 2302 is a single channel battery simulator, functions related to the second channel (i.e., the charger channel) are not available for the Model 2302. Therefore:*

- *battery and charger channel features contained in this manual apply for the Model 2306*
- *only battery channel features contained in this manual apply for the Model 2302*

*Refer to Appendix F of Instruction Manual (2306-901-01) for specific Model 2302 information.*

*Information contained in this guide applies to all power supply channels (unless otherwise noted). In this manual, channel 1 refers to the battery channel while channel 2 refers to the charger channel (2306 feature only).*

**Figure 1**  
*Model 2306 front panel*



## Introduction

This guide is designed to familiarize users of the Keithley Model 2306 Dual Channel Battery/Charger Simulator and Model 2302 Single Channel Battery Simulator with the basic operating features available from the instrument's front panel and also the GPIB Bus. The sequence of operating instructions reflects the order in which the instrument would be configured for a typical application. For each operating mode, an example set of bus commands is provided. While the SCPI command strings are generic, the exact programming syntax will depend on the test program language.

## Performance features

The battery channel, the single output channel of the Model 2302 and channel #1 on the Model 2306, has several enhanced performance features:

1. The transient response, defined by the voltage recovery time and voltage drop when subjected to a 1000% load change, is faster. For exact specifications refer to Appendix A in the Model 2306 Instruction Manual.
2. Three current trigger ranges (100 mA, 1A, and 5A) for pulsed current and long integration operation as opposed to a single range on the charger channel, channel #2 (5A).
3. Variable output impedance on channel #1 ( $0\Omega$  to  $1.00\Omega$  in  $0.01\Omega$  steps). Channel #2 has fixed output impedance.

## Proper connection of the supply to the DUT

**WARNING** When installing a unit into a test system, make sure the external power sources do not apply voltage to the power supply in excess of its maximum limits (see specifications). Failure to do so could result in personal injury or death.

**WARNING** The power cord supplied with the Model 2306 contains a separate ground for use with grounded outlets. When proper connections are made, instrument chassis is connected to power line ground through the ground wire in the power cord. Failure to use a grounded outlet may result in personal injury or death due to electric shock.

Figure 2 shows a rear panel view of the Model 2306 detailing the connector sockets for the battery channel "OUTPUT #1" and the charger channel "OUTPUT #2." The Model 2306 does not have an internal local sense connection. Therefore, the operator must connect the DUT to the supply in either a remote or local sense configuration as illustrated. For a 4-wire remote sense application, the sense inputs to the supply must be connected at load as close to the inputs of the load as possible through twisted pair leads as shown in Figure 3.



Figure 2  
Rear panel view of Model 2306

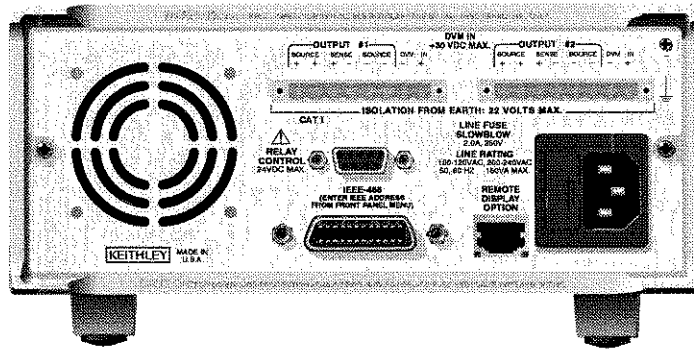
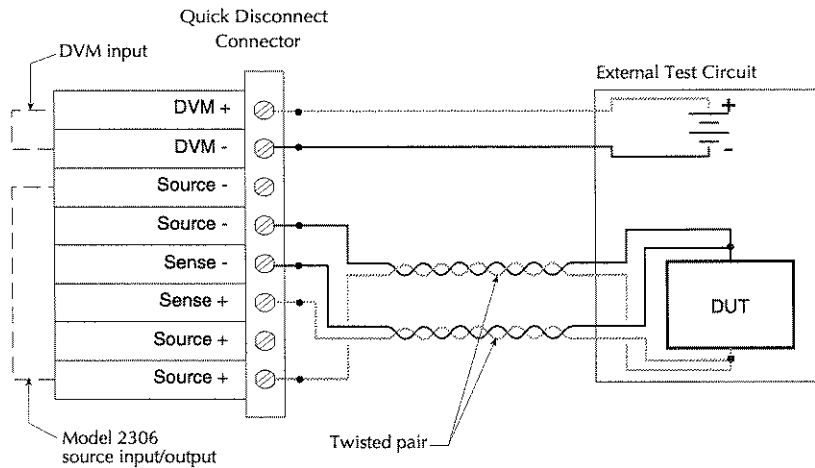


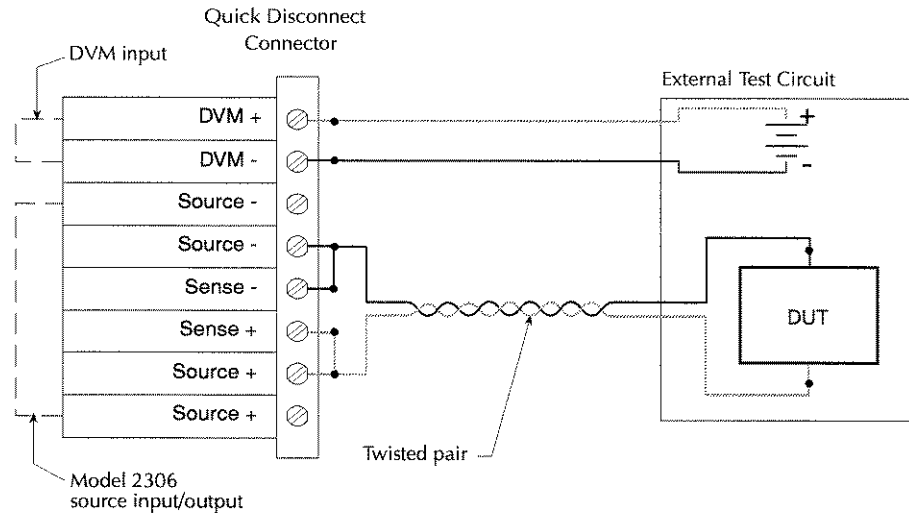
Figure 3  
4-wire remote sense connection of the DUT to the output



**NOTE** DO NOT jumper the sense inputs and supply outputs at the rear of the supply.  
DO NOT pass the source and sense leads together in the same twisted pair.

Failure to connect the sense leads in this fashion will severely compromise the performance of Model 2306 with dynamic loads. Figure 4 illustrates the proper connection of the supply to the DUT using a 2-wire local sense configuration.

**Figure 4**  
2-wire local sense connection of the DUT to the output



## Front panel operation

### Menu controls

- Press the MENU key to activate the main menu.
- Use the UP and DOWN keys to scroll through the primary menu items.
- Changing channels (Model 2306 only): When the main menu is displayed, use the ◀/▶ keys to change the active channel (each press of the ◀/▶ keys will toggle between channel #1 and channel #2).

**NOTE** If a channel number is not shown, the LEFT and RIGHT key presses will be ignored. Also the LEFT and RIGHT key presses will be ignored if a sub-menu only exists on the battery channel (not on the charger channel).

### Setting the output voltage, current range, and current limit

Output voltage can be set from 0 to 15V, and there are two ranges for current, 5A and 5mA. Current range is checked or changed from the CURRENT RANGE item of the MENU.

1. Press the SET key to select the Output Settings Mode. A blinking cursor appears in the voltage field of the display.
2. Use the ◀, ▶, ▲ and ▼ keys to key in the desired output voltage value and press SET. The blinking cursor moves to the current field of the display.



3. Use the ◀, ▶, ▲, and ▼ keys to key in the desired current limit and press SET to exit from the output settings mode.
4. CURRENT RANGE #1/#2 can be checked or changed from the menu (which is accessed by pressing the MENU key). The “#1” (battery channel active) or “#2” (charger channel active) will appear on the top line of the display.

**NOTE** The active channel may be toggled in any of the main menu items by using the ◀/▶ keys. The ◀/▶ keys will not change the active channel in the sub-menu items.

## Turning supply output ON/OFF

The OPERATE key is used to control the output of the power supply. This key toggles the output between on and off. While in one of the display modes, output ON or OFF is displayed in the upper right corner of the display. The key is active in any front panel menu or display mode. In menus, the on/off state of operate is not displayed.

## Actual V and I mode

Measured output voltages and currents are displayed with the actual V and I display mode selected. This display mode is selected as follows:

**NOTE** To display measured readings if the instrument is in the settings mode, press the SET key until the blinking stops (the measured readings can then be displayed). To determine if the instrument is in the settings mode, check for a blinking cursor in a digit of the voltage or current field (if present, the instrument is in the setting mode).

1. Press the DISPLAY key to access the display menu. DISPLAY TYPE #1 (battery channel active) or DISPLAY TYPE #2 (charger channel active) will appear on the top line of the display. Toggle the active channel if necessary.
2. Press the ▲/▼ keys until “ACTUAL V AND I” is displayed.
3. Press ENTER. Voltage readings are located on the top line of the display and current readings are located on the bottom line.

## NPLC rate

The integration (reading) rate of the instrument is specified as a parameter based on the number of power-line cycles (NPLC), where 1 PLC for 60Hz line frequency is 16.67msec. In general, the fastest integration time (0.01 PLC) results in increased reading noise. The slowest integration time (10 PLC) provides the best common-mode and normal-mode rejection. In between settings are a compromise between speed and noise. The NPLC RATE #1/#2 item of the menu is also used to set the reading rate for DVM measurements.

**NOTE** *NPLC RATE is not used to set the integration rate for pulse current and long integration measurements. These measurements are covered in the paragraphs titled “Pulse current mode” on page 8 and “Long integration mode” on page 15.*

**Average readings**

The average reading count (1 to 10) specifies the number of measurement conversions to average for each reading. For example, with a reading count of 5, each displayed reading will be the average of five measurement conversions. The AVER READINGS #1/#2 menu items are also used to set the average reading count for DVM measurements.

**NOTE** *AVER READINGS is not used to set the average reading count for pulse current and long integration measurements. Refer to applicable sections of this guide for information on setting the average reading count for pulse current and long integration measurements.*

**Programming examples: outputting and reading back V and I**

The following command sequences demonstrates how to output voltage and current, and read back (measure) the actual voltage and current:

**Battery channel (#1)**

Command	Description
VOLT 5	‘ Set output voltage to 5V.
SENS:CURR:RANG:AUTO ON	‘ Enable auto range for current.
CURR 750e-3	‘ Set current limit to 750mA.
CURR:TYPE TRIP	‘ Select Trip mode for current limit.
SENS:FUNC ‘VOLT’	‘ Select the voltage measurement function.
SENS:NPLC 2	‘ Set integration rate to 2 PLC.
SENS:AVER 5	‘ Set average reading count to 5.
OUTP ON	‘ Turn on the power supply output.
READ?	‘ Trigger 5 voltage measurement conversions and return the average of those 5 conversions. The average reading is displayed on the front panel.
SENS:FUNC ‘CURR’	‘ Select current measurement function.
READ?	‘ Trigger 5 current measurement conversions and return the average of those 5 conversions. The average of the 5 readings is displayed on the front panel.

**Charger channel (#2)**

Command	Description
SOUR2:VOLT 5	' Set output voltage to 5V.
SENS2:CURR:RANG:AUTO ON	' Enable auto range for current.
SOUR2:CURR 750e-3	' Set current limit to 750mA.
SOUR2:CURR:TYPE LIM	' Select LIM mode for current limit.
SENS2:FUNC 'VOLT'	' Select the voltage measurement function.
SENS2:NPLC 4	' Set integration rate to 4 PLC.
SENS2:AVER 4	' Set average reading count to 4.
OUTP2 ON	' Turn on the power supply output.
READ2?	' Trigger 4 voltage measurement conversion and return the average of those 4 conversions.
SENS2:FUNC 'CURR'	' Select current measurement function.
READ2:ARR?	' Trigger 4 current measurement conversions and return all 4 conversions. The average of the 4 readings is displayed on the front panel.

**DVM input mode**

The DVM input display mode must be selected in order to measure voltage applied to DVM input of the power supply. This display mode is selected as follows:

1. Press the DISPLAY key to access the display menu. DISPLAY TYPE #1 (battery channel active) or DISPLAY TYPE #2 (charger channel active) will appear on the top line of the display. Toggle the active channel if necessary by using the left or right arrow keys.
2. Press the ▲/▼ key until "DVM INPUT" is displayed.
3. Press ENTER.

**Programming examples: making voltage measurements with the DVM**

The following command sequence demonstrates how to measure voltage applied to the DVM input of the power supply:



**Battery channel (#1)**

Command	Description
SENS:FUNC 'DVM'	' Select the DVM input function.
SENS:NPLC 6	' Set integration rate to 6 PLC.
SENS:AVER 10	' Set average reading count to 10.
READ:ARR?	' Trigger and return 10 readings. The average of the 10 readings is displayed on the front panel.

**Charger channel (#2)**

Command	Description
SENS2:FUNC 'DVM'	' Select the DVM input function.
SENS2:NPLC 3	' Set integration rate to 3 PLC.
SENS2:AVER 8	' Set average reading count to 8.
READ2:ARR?	' Trigger and return 8 readings. The average of the 8 readings is displayed on the front panel.

**Pulse current mode**

**Description**

The Model 2306 can perform pulsed current measurements for dynamic loads. The built-in measurements include:

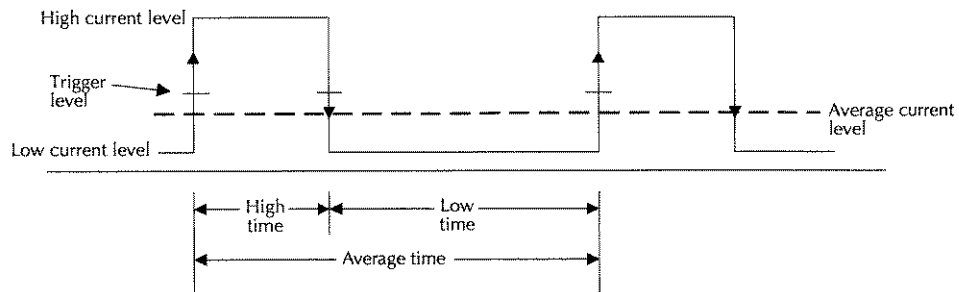
1. Peak measured current - measures the peak (high) current of the pulse train.
2. Idle measured current - measures the idle (low) current of the pulse train.
3. Average transmitted current - measures the average current of the pulse train.

The high measurement is triggered on the rising edge of the pulse (Figure 5) and an integration is performed for the time specified for the high measurement. The falling edge of the pulse triggers the low measurement, and an integration is performed for the time specified for the low measurement. An average measurement is triggered on the rising edge, and covers both the high and low periods of the pulse as specified by the average measurement time setting. The Model 2306 computes one measurement parameter, high, low, or average, at a time. The desired measurement mode on the front panel is selected with the up and down arrow keys.



The pulse measurement period  $T$  can be selected manually or be automatically set by the Model 2306. First, the user must specify a trigger level that serves as a threshold to initiate integration process, i.e., at  $t = 0$ . Once the trigger level is selected, the output is turned on and the pulsed load is operational, the 2306 can be prompted to automatically determine the high time, low time, and average time in pulsed current mode according to Figure 5. These parameters may also be set manually from the front panel or over the GPIB bus.

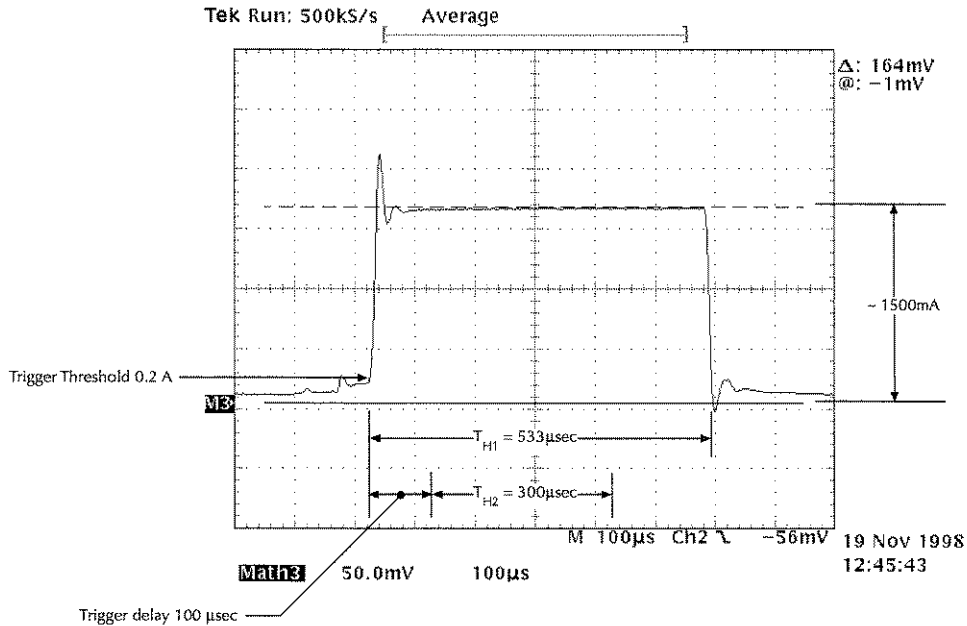
**Figure 5**  
Pulsed waveform



**NOTE** The pulsed waveform in Figure 5 shows trigger level and the high, low, and average times set by the Model 2306 using the auto-time feature.

The pulsed response of a device is rarely a perfect square wave. Figure 6 shows the current response of a typical GSM handset during the transmit portion of the data frame. Using the built in auto-time feature with a trigger threshold of 0.2 amp and no trigger delay, the Model 2306 will automatically set the HIGH integration time, denoted by  $T_{H1}$ , to 533 $\mu$ s. For this value of HIGH integration time, the effect of the current transient at the beginning of the pulse is included in the measurement. Although in this example the effect of the current transient on the measurement is small, the user can eliminate the effect of the transient by adding a suitable amount of trigger delay. In this case, a delay of 100 $\mu$ s is sufficient to eliminate the effect of transient, approximately 70 $\mu$ s, from the measurement. Accordingly, the HIGH integration time,  $T_{H2}$ , must be reduced, in this case 300 $\mu$ s was chosen, so the integration time does not extend into a section of the pulse the user does not want to measure.

**Figure 6**  
Eliminating the effect of a current transient on a pulse current measurement



**NOTE** In Figure 6, a trigger delay of 100µs is used to eliminate the effect of a current transient on the pulse current measurement.

**Front panel operation (for pulse current measurements)**

All of the following settings are available in sub-menus of PULSE CURRENT #1/#2 main menu item. Scroll through the main menu and when PULSE CURRENT #1/#2 is displayed press “ENTER” to access the sub-menus.

**Turn on the output**

Press the OPERATE key after setting the appropriate voltage and current limits for the DUT.

**Trigger level and range — “TRIG LEVEL RANGE” and “TRIGGER LEVEL” sub-menus**

Battery Channel (#1) — The trigger level can be set for either the 5A, 1A, or 100mA range.

Trigger level ranges: 5A range: 0–5A in 5mA steps

1A range: 0–1A in 1mA steps

100mA range: 0–100mA in 0.1mA steps

To change the range for the trigger level setting, place the blinking cursor on the "A" at the far right end of line two of the display, and press the UP or DOWN key. After keying in the trigger level (in amps), press ENTER to update the displayed range for that trigger level setting only.

Charger Channel (#2) — Set the trigger level from 0 to 5A in 5mA steps.

Same as battery channel but settings for one range only 5A range: 0–5A in 5mA steps.

If the trigger level is incorrect or the DUT is not functioning properly, the "PULSE CURR TRIG NOT DETECTED" message will be displayed. (See note No Pulses Detected message on page 12.)

**Integration time (manual setting) "AVERAGE TIME", "LOW TIME", and "HIGH TIME" sub-menus**

The values for HIGH, LOW, and AVERAGE time may be changed in 33.3333  $\mu$ sec intervals with the UP and DOWN keys. Range of values is 33.3333 $\mu$ sec to 833.33msec.

**Integration time (auto time setting) "AUTO TIME" sub-menu**

Press ENTER when "ACQUIRE TIMES" appears on the display. If the correct trigger level is selected in the previous step and the DUT is operating, the Model 2306 will automatically determine the HIGH, LOW, and AVERAGE times. If the trigger level is incorrect or the DUT is not functioning properly the message "PULSE CURR TRIG NOT DETECTED" will be displayed. (See note No Pulses Detected message on page 12.)

**Trigger delay (if necessary) channel #1 and channel #2:**

The trigger level is changed in the TRIGGER LEVEL sub-menu by pressing the UP or DOWN key.

Range is 0 – 0.100sec in 10 $\mu$ sec increments.

**NOTE** *The high, low, or average integration times can be set either manually or automatically. When a pulse is detected, there is a 15 $\mu$ sec trigger latency before the integration time begins. An additional user trigger delay can be set to allow the leading edge pulse overshoot to settle. Regardless of the user trigger delay setting, the internal trigger delay is always present.*

**Average readings count (if necessary) Channel #1 and Channel #2:**

The AVERAGE READINGS sub-menu of the PULSE CURRENT #1/#2 menu item is used to set the average readings count for pulse current measurements. This count specifies the number of measurements (integrations) to average for each reading. Range is 1 – 100.

### Pulse current display mode

Pulse current measurements are displayed with the pulse current display mode selected. This display mode is selected as follows:

**NOTE** *To display measured readings if the instrument is in the settings mode, press the SET key until the blinking stops (the measured readings can then be displayed). To determine if the instrument is in the settings mode, check for a blinking cursor in a digit of the voltage or current field (if present, the instrument is in the settings mode).*

1. Press the DISPLAY key to access the display menu.
2. If the desired active display is not selected, use the LEFT and RIGHT keys to toggle the active display. The top line of the display will show which output channel is active.
3. Press the UP or DOWN key until "PULSE CURRENT" is displayed and press ENTER.
4. Use the UP or DOWN key to display the desired pulse measurement; high, low, or average.

### NOTES No Pulses Detected message

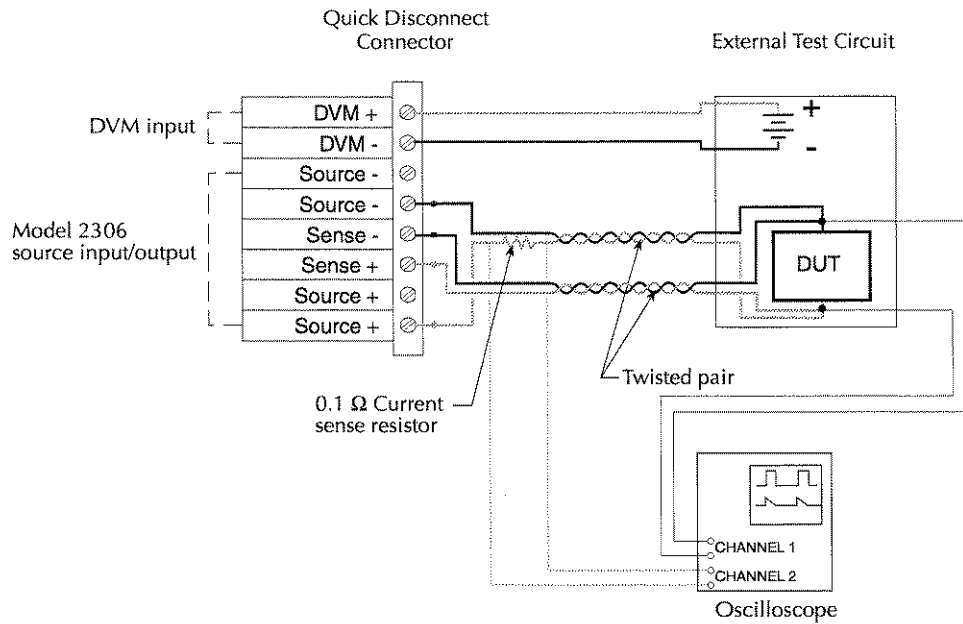
*If no pulses are detected, current will not be measured (i.e., ----A), and the "NO PULSE" message will be displayed. The "NO PULSE" message is displayed with dashes or the last valid pulse reading. Dashes are shown if the pulse-current measurement settings are not appropriate for detecting pulses. The last valid pulse is shown if the pulse disappears while taking readings and no change in pulse settings was made.*

*Pulses are not detected with the output OFF. With the output ON, pulses will not be detected if the trigger level is too low or too high. Adjust the trigger level as necessary and toggle back to the display mode until pulse measurements are displayed.*

**NOTE** *If possible, the user should always use an oscilloscope to determine the timing and transient characteristics of a DUT. The waveform information is very useful in setting up the Model 2306, reducing setup time, and achieving maximum performance and productivity. The voltage and current characteristics of the DUT can be determined with a two-channel oscilloscope, a 0.1 ohm resistor used as a current sense resistor, and a voltage probe at the DUT as shown in Figure 7.*



**Figure 7**  
 Circuit — determining the dynamic voltage and current characteristics of a DUT



**NOTE** Figure 7 contains a simple circuit for determining the dynamic voltage and current characteristics of the DUT using a 2-channel oscilloscope, a 0.1 ohm resistor used as a current sense resistor, and a voltage probe at the DUT.

### Programming examples: pulse current measurements

The following command sequence will return the average of 10 peak pulse current measurements:

#### Battery channel (#1)

Command	Description
SENS:RANG 5	' Select 5A range.
VOLT 15	' Set output voltage to 15V.
CURR 0.75	' Set current limit to 750mA.
OUTP ON	' Turn output on.
SENS:PCUR:SYNC ON	' Enable trigger synchronization.
SENS:PCUR:AVER 10	' Set average count to 10.
SENS:PCUR:SYNC:TLEV:RANG 0.5	' Select the 1A trigger level range.
SENS:PCUR:SYNC:TLEV:ONE 0.1	' Set trigger level to 100mA for 1A trigger level range.
SENS:PCUR:TIME:AUTO	' Set integration times automatically.
SENS:PCUR:SYNC:DEL 50e-3	' Set trigger delay to 50msec.
SENS:FUNC "PCUR"	' Select pulse current function.
SENS:PCUR:MODE HIGH	' Configure to measure peak pulse.
READ?	' Trigger 10 measurement conversions and return the average of those 10 conversions. The average of the 10 conversions is displayed on the front panel. Each of the 10 conversion syncs to the rising edge.



**Charger channel (#2)**

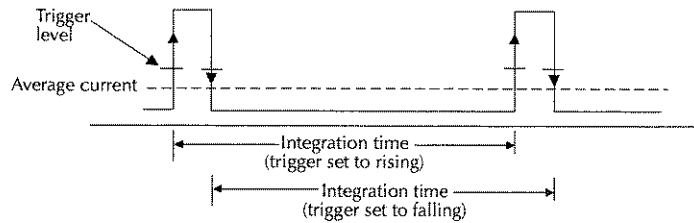
Command	Description
SENS2:RANG 5	‘ Select 5A range.
SOUR2:VOLT 15	‘ Set output voltage to 15V.
SOUR2:CURR 0.75	‘ Set current limit to 750mA.
OUTP2 ON	‘ Turn output on.
SENS2:PCUR:SYNC ON	‘ Enable trigger synchronization.
SENS2:PCUR:AVER 10	‘ Set average count to 10.
SENS2:PCUR:SYNC:TLEV 0.1	‘ Set trigger level to 100mA.
SENS2:PCUR:TIME:AUTO	‘ Set integration times automatically.
SENS2:PCUR:SYNC:DEL 50e-3	‘ Set trigger delay to 50msec.
SENS2:FUNC “PCUR”	‘ Select pulse current function.
SENS2:PCUR:MODE HIGH	‘ Configure to measure peak pulse (trigger on).
READ2	‘ Trigger 10 measurement conversions and return the average of those 10 conversions. The average of the 10 conversions is displayed on the front panel. Each of the ten conversion syncs to the rising edge.

**Long integration mode**

In the long integration mode, a current measurement results from a continuous integration of the dynamic current for a period ranging from approximately 850ms to 60sec set in 1msec increments. The Model 2306 can determine the integration time automatically or the user can set the integration time manually from the front panel. A pulse edge can be used to trigger the start of the measurement as shown in Figure 8. Select **RISING** to use a rising pulse edge to start the measurement. Select **FALLING** to use a falling pulse edge to start the measurement. A third option is available if you do not want measurements controlled by pulse edges. With **NEITHER** selected, measurements will start as soon as the long integration function is selected. Note that a pulse has to be detected before a **RISING** or **FALLING** pulse edge can trigger a long integration measurement (see Trigger Level and Range on page 16). To average over several pulse periods, the user must enter the sum of the pulse periods as the integration time.

The GPIB commands **TIMEOUT**, **SEARCH**, **DETECT**, and **FAST** are available exclusively in the long integration mode to optimize measurement speed. For the relevance and use of these commands regarding a particular measurement application, refer to the Model 2306 Instruction Manual, Section 4, Long Integration Measurements.

**Figure 8**  
Pulsed waveform



**NOTE** The pulse waveform contained in Figure 8 shows trigger level and the integration time used by the Model 2306 for pulse current measurements.

### Front panel operation for performing long integration measurements

All of the following settings are available in sub-menus of the LONG INTEGRAT #1/#2 main menu item. Scroll through the main menu and when LONG INTEGRAT #1/#2 is displayed press “ENTER” to access the sub-menus.

#### Turn on the output

Press the OPERATE key after setting the appropriate voltage and current limits for the DUT.

#### Trigger level and range – “TRIG LEVEL RANGE” and “TRIGGER LEVEL” sub-menus

Battery Channel (#1) — The trigger level can be set for either the 5A, 1A, or 100mA range.

Trigger level ranges: 5A range: 0–5A in 5mA steps

1A range: 0–1A in 1mA steps

100mA range: 0–100mA in 0.1 mA steps

To change the range for the trigger level setting, place the blinking cursor on the “A” at the far right end of line two of the display, and press the UP or DOWN key. After keying in the trigger level (in amps), press ENTER to update the displayed range for that trigger level setting only.





Charger Channel (#2) — Set the trigger level from 0 to 5A in 5mA steps.

**NOTE:** *This is the same as battery channel but settings are for only one range, the 5A range: 0–5A in 5mA steps.*

If the trigger level is incorrect or the DUT is not functioning properly, the message “LONG INT TRIG NOT DETECTED” will be displayed. (See the LONG INT TRIG NOT DETECTED note on page 18.)

#### **Trigger edge – “TRIGGER EDGE” sub-menus**

Toggle between the RISING, FALLING, and NEITHER settings with the UP and DOWN keys. With NEITHER selected, measurements will start as soon as the long integration function is selected.

#### **Timeout – “TIMEOUT” sub-menu**

When the TIMEOUT value is reached, NO PULSE is displayed (top line of the front panel display). The value for TIMEOUT should be set to a value greater than the long integration time for a long integration reading.

#### **Manually setting long integration time (“INTEGRATION TIME” sub-menu)**

The value for LINT INT TIME for channel #1 or channel #2 can be specified in 0.850 sec to 60 sec (i.e. @ 60Hz) with the UP and DOWN keys.

#### **Automatically setting long integration time (“AUTO TIME” sub-menu)**

Press ENTER when “LINT AUTOTIME #1, #2”, “ACQUIRE TIMES” appears on the display. If the correct trigger level is selected in the previous step and the DUT is operating, the Model 2306 will automatically determine the INTEGRATION times. If the trigger level is incorrect or the DUT is not functioning properly, the message “LONG INT TRIG NOT DETECTED” will be displayed. (See the LONG INT TRIG NOT DETECTED note on page 18.)

#### **Long integration display mode**

Long integration measurements are displayed with the long integration display mode selected. This display mode is selected as follows:

**NOTE** *To display measured readings if the instrument is in the settings mode, press the SET key until the blinking stops (the measured readings can then be displayed). To determine if the instrument is in the settings mode, check for a blinking cursor in a digit of the voltage or current field (if present, the instrument is in the setting mode).*

1. Press the DISPLAY key to access the display menu.
2. If the desired active display is not selected, use the LEFT and RIGHT keys to toggle the active display. The top line of the display will show which output channel is active.
3. Press the UP or DOWN key until “LONG INTEGRATION” is displayed and press ENTER.

4. To stop taking long integration readings, press any front panel key. As long as the instrument remains in the long integration display state, the measurement process can be resumed by pressing the UP or DOWN key.

**NOTE** *LONG INT TRIG NOT DETECTED message*

*This message may take a few seconds to appear. With the trigger edge set to NEITHER, this message may appear if level setting causes no rising edge detection. A valid trigger level is not required if the trigger edge is set to NEITHER. For the battery channel (#1), this message will only appear if the range of the trigger level setting matches the selected trigger level range. For the charger channel #2, the trigger level range setting is not user selectable.*

**NOTE** *If you select AUTO TIME to set the integration time, the pulse timeout message "LONG INT TRIG NOT DETECTED" will display if the output is OFF. This message indicates that the integration time has not been updated. To update the integration time, select AUTO TIME after the output is turned ON.*

**Programming examples: long integration measurements**

The following command sequence will trigger and return one long integration measurement:

**Battery channel (#1)**

Command	Description
SENS:RANG 5	‘ Select 5A range.
VOLT 15	‘ Set output voltage to 15V.
CURR 0.75	‘ Set current limit to 750mA.
OUTP ON	‘ Turn output on.
SENS:LINT:TLEV:RANG 0.5	‘ Select 1A trigger level range.
SENS:LINT:TEDG RISING	‘ Select rising trigger edge to initiate measurement.
SENS:LINT:TLEV:ONE 0.1	‘ Set trigger level to 100mA for 1A trigger-level range.
SENS:LINT:TIME:AUTO	‘ Set integration time automatically for single pulse.
SENS:FUNC "LINT"	‘ Select long integration function.
READ?	‘ Trigger and return one reading and reading shown on display.

**Charger channel (#2)**

Command	Description
SENS2:RANG 5	‘ Select 5A range.
SOUR2:VOLT 15	‘ Set output voltage to 15V.
SOUR2:CURR 0.75	‘ Set current limit to 750mA.
OUTP2 ON	‘ Turn output on.
SENS2:LINT:TEDG RISING	‘ Select rising trigger edge to initiate measurement.
SENS2:LINT:TLEV 0.1	‘ Set trigger level to 100mA.
SENS2:LINT:TIME:AUTO	‘ Set integration time automatically for single pulse.
SENS2:FUNC “LINT”	‘ Select long integration function.
READ2?	‘ Trigger and return one reading and reading shown on display.

## Advanced features

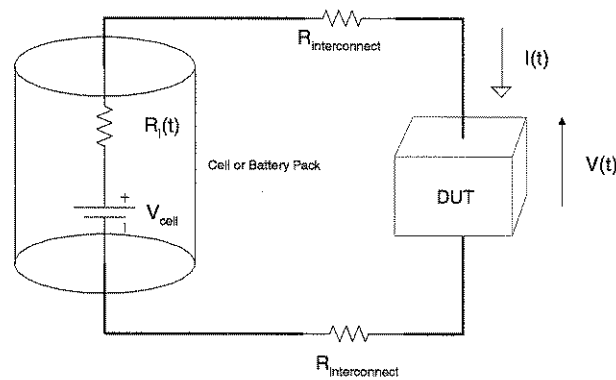
### Simulating battery impedance

The electronic resistance of batteries varies according to a variety of factors such as chemistry, cell construction, number of charge/discharge cycles, temperature, and depth of discharge. If a battery is used as a source in a circuit with a dynamic load, changes in the voltage across the load will be produced proportional to the electronic resistance of the battery and other sources of resistance in the circuit. If the peak load current is high enough or the electronic resistance of the battery and the resistance between the source and the DUT is large, the voltage drop compromises the performance of the device.

This phenomenon occurs in TDMA and GSM cellular handsets where the magnitude of the “ON/OFF” current during transmission varies by as much as a factor of 20. In the absence of any filtering capacitance between the battery and the RF power amplifier, the handset will shut off if the supply voltage is below the operating threshold for periods as short as several microseconds.

Figure 9 shows a simple schematic of a battery. This battery is represented by an ideal voltage source,  $V_{\text{cell}}$ , with internal impedance,  $R_1(t)$ , and is connected to a DUT with interconnects having resistance  $R_{\text{interconnect}}$ .

**Figure 9**  
Battery schematic



If  $R_{\text{interconnect}}$  is small compared to  $R_i(t)$  and if  $R_i(t)$  is relatively constant during the length of the pulse,  $R_i(t) \sim R_i$ , then the voltage across the DUT may be expressed as:

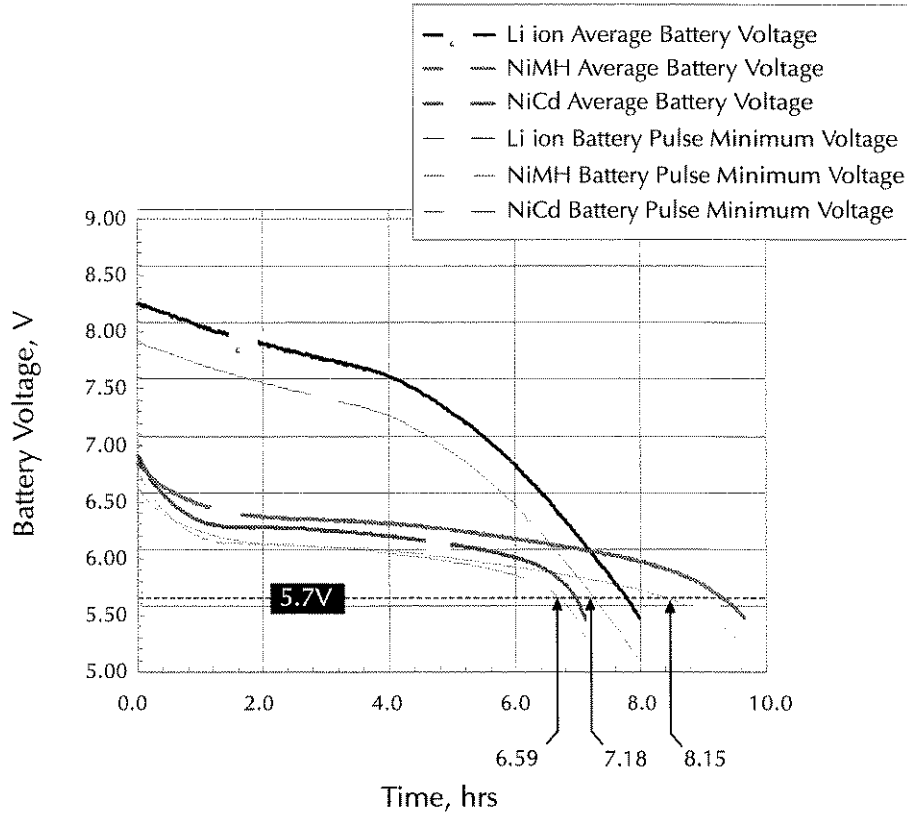
$$V(t) = V_i - I(t)R_i$$

where  $I(t)$  is the time varying current through the battery.

Figure 10 shows the actual performance of typical Li ion, NiMH, and NiCd handset battery packs with a dynamic load, shown in Figure 11, simulating a GSM handset during transmission. The pulse minimum voltage is the voltage at the battery terminals during the transmit, or high current portion, of the data frame. The average battery voltage is the voltage across the terminals measured with a 6½ digit DMM at approximately 50 readings per second. The figure shows the pulse minimum voltage reaches the shutdown threshold of 5.7V before the average battery voltage. The difference between the pulse minimum and average battery voltage also varies as a function of the electronic resistance with time. Figure 12 shows the variations for specific battery packs and ranges between 200 and 500mV. The results of these measurements prove that the impedance of the battery must be considered when evaluating handset performance, especially near the end of life for the battery pack.

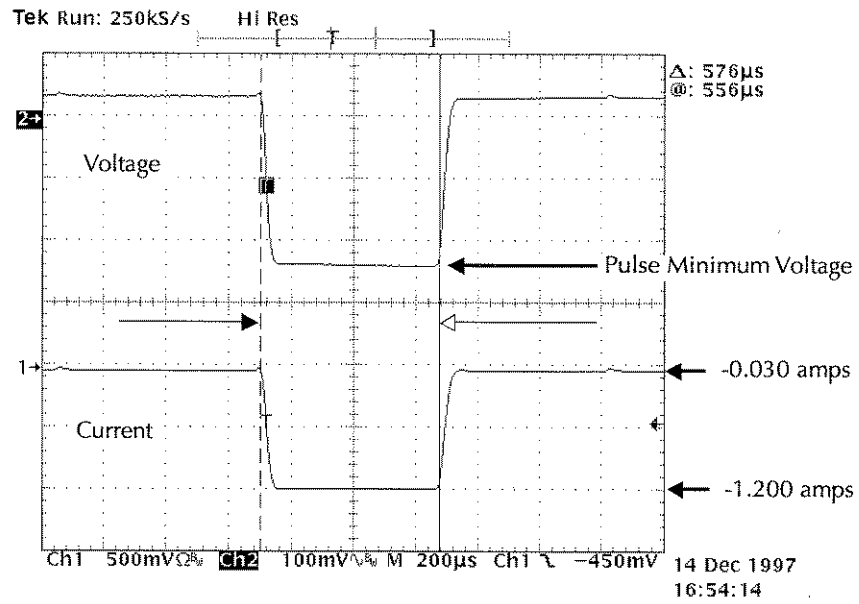


**Figure 10**  
Actual battery pack terminal voltage during GSM phone simulation



**NOTE** Figure 10 shows the average and minimum battery pack terminal voltage during a load pulse from a dynamic load simulating a GSM phone.

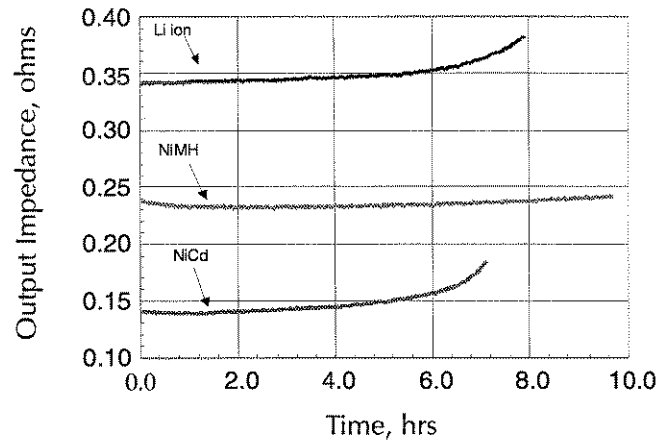
**Figure 11**  
*Simulated GSM phone current profile*



**NOTE** The simulated GSM phone current profile contained in Figure 11 shows a standby current of .030A, a transmit current of 1.2A, and the pulse minimum voltage during the transmit frame.



**Figure 12**  
*Electronic resistance of NiCd, NiMH, and Li ion battery packs*



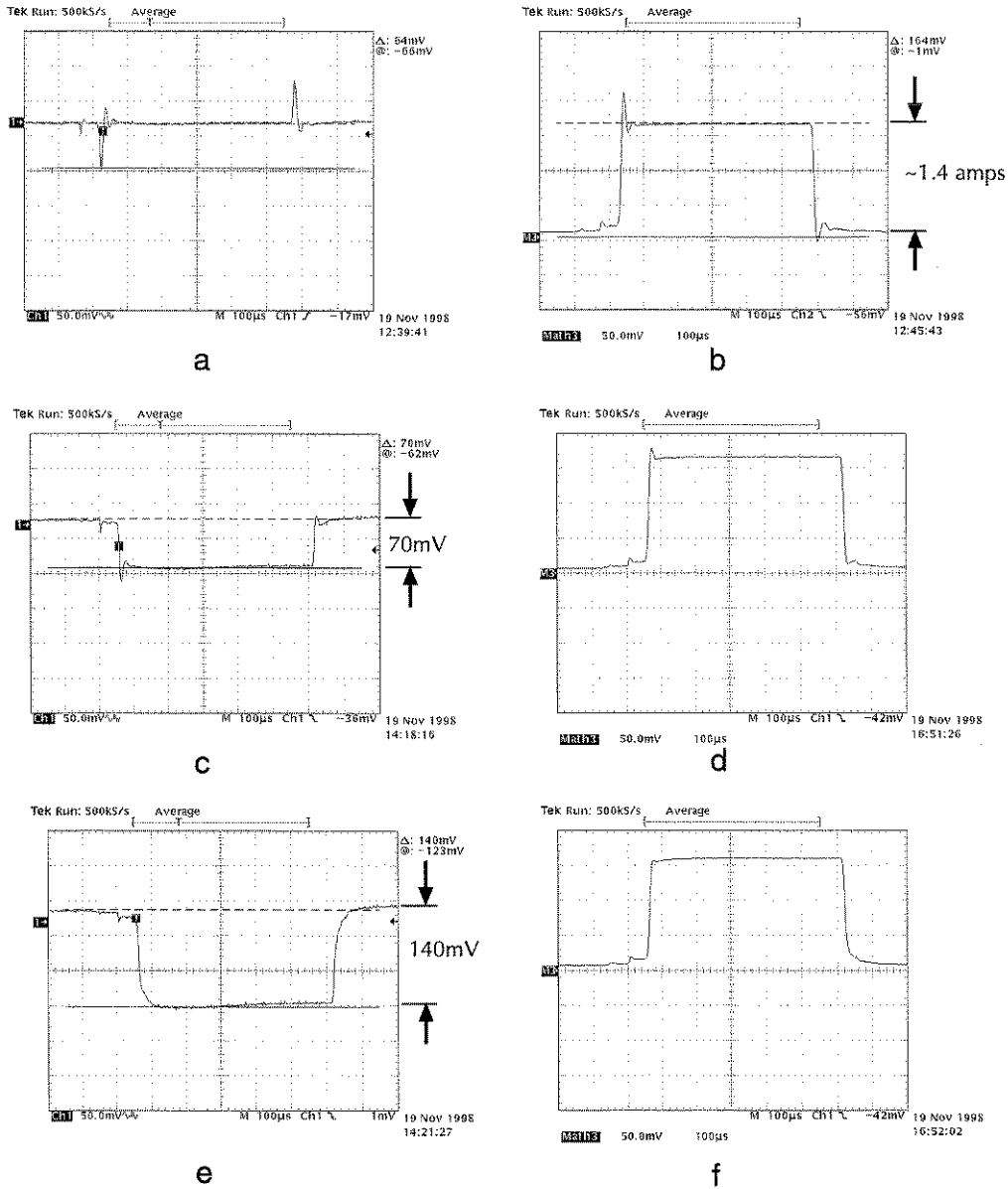
**NOTE** Figure 12 shows electronic resistance for battery packs during a simulated GSM phone pulsed discharge from full charge to 5.5 volts.

### Variable output impedance control on channel #1

Channel #1 of the Model 2306 has a variable output impedance control that can be used to simulate the impedance of a battery pack. The output impedance may be set from 0.00 ohms (default condition) to 1.00 ohms in 0.01 ohm increments from the front panel or over the GPIB bus.

Figure 13 shows the output voltage and current response of channel #1 with a GSM phone for output impedance values of 0.00, 0.05, and 0.10 ohms. The voltage drop, 70mV in **c** and 140mV in **e**, is approximately equal to the dynamic load current, 1.4A, multiplied by the output impedance, **c** (0.05 ohms) and **e** (0.10 ohms).

**Figure 13**  
Effect of variable output impedance control

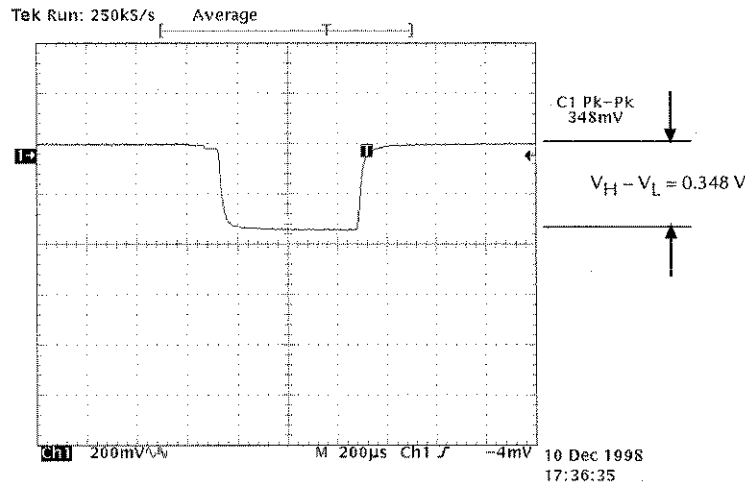


**NOTE** Figure 13 contains the effect of the variable output impedance control of the Model 2306 on the current and voltage performance of a GSM handset.



Two methods are used to determine the impedance value of the cell or battery pack. The first method uses data from the battery manufacturer or another source and is simply entered into the Model 2306 from the front panel or over the GPIB bus. The second method involves a simple series of measurements as follows.

**Figure 14**  
Voltage drop sample (with supplied Li ion battery pack)



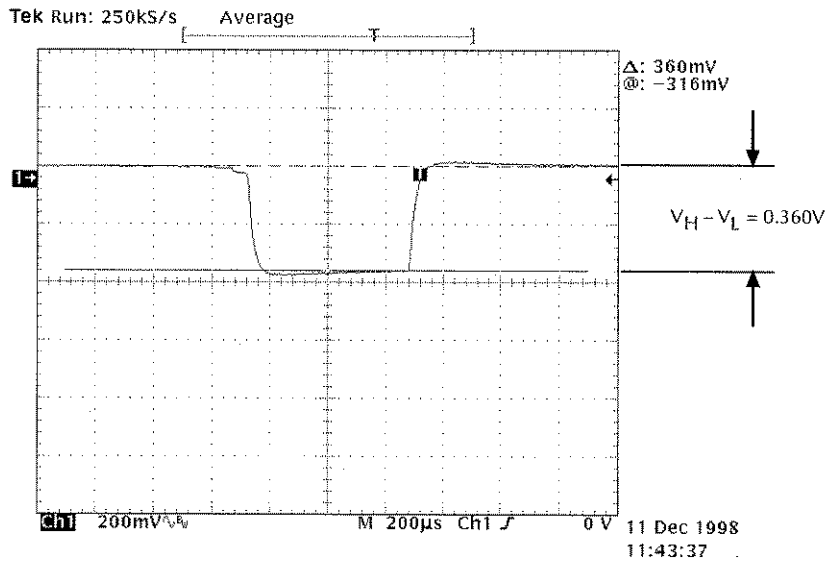
**NOTE** Figure 14 shows the voltage drop during the transmit portion of the pulse with the supplied Li ion battery pack. See Figure 15 for the comparative illustration using the Model 2306.

Figure 14 shows the transient voltage response at the battery terminals with the handset battery. Using Figure 14, the voltage drop during the transmit portion of the pulse of a GSM phone with the supplied Li ion battery is 0.348V. Using the pulse current mode of the battery channel the measured current during the transmit portion of the data frame is  $I_H = 1.536A$  and the idle portion of the data frame is  $I_L = 0.082A$ . To estimate  $R_i$  from the measured voltage, we use:

$$R_i = \frac{V_H - V_L}{I_H - I_L} = \frac{0.348V}{1.454A} = 0.239\Omega$$

Using this value for the output impedance setting in the battery channel, the voltage drop across the output terminals, as shown in Figure 15, is 0.360V. This value is in agreement, to within 3%, with the results obtained with the battery included with the handset.

**Figure 15**  
Voltage drop sample (with Model 2306 and output impedance set at 0.24Ω)



**NOTE** Figure 15 shows the voltage drop during the transmit portion of the pulse of a GSM phone using the Model 2306 battery channel with output impedance set to 0.24Ω. See Figure 14 for actual Li ion battery results.

### Variable output bandwidth

Testing the performance of the battery charger circuitry in a handset does not require the high bandwidth performance in channel #1 or channel #2 of the Model 2306. Since a charger circuit is a voltage regulated circuit, it resembles a high capacitance load to the output of the Model 2306. For this type of application, the LOW bandwidth output mode provides increased stability and eliminates oscillations that may occur. The LOW bandwidth output mode is selectable from the front panel or over the GPIB bus of the Model 2306.

### Front panel operation for output bandwidth

The following settings are available in main menu under OUT BANDWIDTH #1,#2. Use the UP or DOWN keys to set the desired output bandwidth, either HIGH or LOW.

#### GPIB commands

Command	Description
:OUTPut:BANDwidth HIGH or LOW	' Bandwidth when the output state is ON and current range is set to 5A. When output is OFF, the bandwidth is LOW. When current range is 5mA, bandwidth is LOW.
:OUTPut2:BANDwidth HIGH or LOW	' Same as above, but for output channel #2.

