

Model 2010  
Multimeter  
Service Manual

Contains Calibrating and Servicing Information

**KEITHLEY**

---

## WARRANTY

Keithley Instruments, Inc. warrants this product to be free from defects in material and workmanship for a period of 3 years from date of shipment.

Keithley Instruments, Inc. warrants the following items for 90 days from the date of shipment: probes, cables, rechargeable batteries, diskettes, and documentation.

During the warranty period, we will, at our option, either repair or replace any product that proves to be defective.

To exercise this warranty, write or call your local Keithley representative, or contact Keithley headquarters in Cleveland, Ohio. You will be given prompt assistance and return instructions. Send the product, transportation prepaid, to the indicated service facility. Repairs will be made and the product returned, transportation prepaid. Repaired or replaced products are warranted for the balance of the original warranty period, or at least 90 days.

## LIMITATION OF WARRANTY

This warranty does not apply to defects resulting from product modification without Keithley's express written consent, or misuse of any product or part. This warranty also does not apply to fuses, software, non-rechargeable batteries, damage from battery leakage, or problems arising from normal wear or failure to follow instructions.

THIS WARRANTY IS IN LIEU OF ALL OTHER WARRANTIES, EXPRESSED OR IMPLIED, INCLUDING ANY IMPLIED WARRANTY OF MERCHANTABILITY OR FITNESS FOR A PARTICULAR USE. THE REMEDIES PROVIDED HEREIN ARE BUYER'S SOLE AND EXCLUSIVE REMEDIES.

NEITHER KEITHLEY INSTRUMENTS, INC. NOR ANY OF ITS EMPLOYEES SHALL BE LIABLE FOR ANY DIRECT, INDIRECT, SPECIAL, INCIDENTAL OR CONSEQUENTIAL DAMAGES ARISING OUT OF THE USE OF ITS INSTRUMENTS AND SOFTWARE EVEN IF KEITHLEY INSTRUMENTS, INC., HAS BEEN ADVISED IN ADVANCE OF THE POSSIBILITY OF SUCH DAMAGES. SUCH EXCLUDED DAMAGES SHALL INCLUDE, BUT ARE NOT LIMITED TO: COSTS OF REMOVAL AND INSTALLATION, LOSSES SUSTAINED AS THE RESULT OF INJURY TO ANY PERSON, OR DAMAGE TO PROPERTY.

# KEITHLEY

Keithley Instruments, Inc. • 28775 Aurora Road • Cleveland, OH 44139 • 440-248-0400 • Fax: 440-248-6168 • <http://www.keithley.com>

<b>BELGIUM:</b>	<b>Keithley Instruments B.V.</b>	Bergensesteenweg 709 • B-1600 Sint-Pieters-Leeuw • 02/363 00 40 • Fax: 02/363 00 64
<b>CHINA:</b>	<b>Keithley Instruments China</b>	Yuan Chen Xin Building, Room 705 • 12 Yumin Road, Dewai, Madian • Beijing 100029 • 8610-62022886 • Fax: 8610-62022892
<b>FRANCE:</b>	<b>Keithley Instruments Sarl</b>	B.P. 60 • 3, allée des Garays • 91122 Palaiseau Cédex • 01 64 53 20 20 • Fax: 01 60 11 77 26
<b>GERMANY:</b>	<b>Keithley Instruments GmbH</b>	Landsberger Strasse 65 • D-82110 Germering • 089/84 93 07-40 • Fax: 089/84 93 07-34
<b>GREAT BRITAIN:</b>	<b>Keithley Instruments Ltd</b>	The Minster • 58 Portman Road • Reading, Berkshire RG30 1EA • 0118-9 57 56 66 • Fax: 0118-9 59 64 69
<b>INDIA:</b>	<b>Keithley Instruments GmbH</b>	Flat 2B, WILOCRISSA • 14, Rest House Crescent • Bangalore 560 001 • 91-80-509-1320/21 • Fax: 91-80-509-1322
<b>ITALY:</b>	<b>Keithley Instruments s.r.l.</b>	Viale S. Gimignano, 38 • 20146 Milano • 02/48 30 30 08 • Fax: 02/48 30 22 74
<b>NETHERLANDS:</b>	<b>Keithley Instruments B.V.</b>	Postbus 559 • 4200 AN Gorinchem • 0183-635333 • Fax: 0183-630821
<b>SWITZERLAND:</b>	<b>Keithley Instruments SA</b>	Kriesbachstrasse 4 • 8600 Dübendorf • 01-821 94 44 • Fax: 01-820 30 81
<b>TAIWAN:</b>	<b>Keithley Instruments Taiwan</b>	1 Fl. 85 Po Ai Street • Hsinchu, Taiwan, R.O.C. • 886-3572-9077 • Fax: 886-3572-9031

---

# Model 2010 Multimeter Service Manual

©1996, Keithley Instruments, Inc.  
All rights reserved.  
Cleveland, Ohio, U.S.A.  
Third Printing, September 1999  
Document Number: 2010-902-01 Rev. C

---

## Manual Print History

The print history shown below lists the printing dates of all Revisions and Addenda created for this manual. The Revision Level letter increases alphabetically as the manual undergoes subsequent updates. Addenda, which are released between Revisions, contain important change information that the user should incorporate immediately into the manual. Addenda are numbered sequentially. When a new Revision is created, all Addenda associated with the previous Revision of the manual are incorporated into the new Revision of the manual. Each new Revision includes a revised copy of this print history page.

Revision A (Document Number 2010-902-01) .....	January 1996
Revision B (Document Number 2010-902-01) .....	June 1999
Addendum B (Document Number 2010-902-02).....	September 1999
Revision C (Document Number 2010-902-01) .....	September 1999

All Keithley product names are trademarks or registered trademarks of Keithley Instruments, Inc.  
Other brand names are trademarks or registered trademarks of their respective holders.

---

## Safety Precautions

The following safety precautions should be observed before using this product and any associated instrumentation. Although some instruments and accessories would normally be used with non-hazardous voltages, there are situations where hazardous conditions may be present.

This product is intended for use by qualified personnel who recognize shock hazards and are familiar with the safety precautions required to avoid possible injury. Read the operating information carefully before using the product.

The types of product users are:

**Responsible body** is the individual or group responsible for the use and maintenance of equipment, for ensuring that the equipment is operated within its specifications and operating limits, and for ensuring that operators are adequately trained.

**Operators** use the product for its intended function. They must be trained in electrical safety procedures and proper use of the instrument. They must be protected from electric shock and contact with hazardous live circuits.

**Maintenance personnel** perform routine procedures on the product to keep it operating, for example, setting the line voltage or replacing consumable materials. Maintenance procedures are described in the manual. The procedures explicitly state if the operator may perform them. Otherwise, they should be performed only by service personnel.

**Service personnel** are trained to work on live circuits, and perform safe installations and repairs of products. Only properly trained service personnel may perform installation and service procedures.

Exercise extreme caution when a shock hazard is present. Lethal voltage may be present on cable connector jacks or test fixtures. The American National Standards Institute (ANSI) states that a shock hazard exists when voltage levels greater than 30V RMS, 42.4V peak, or 60VDC are present. **A good safety practice is to expect that hazardous voltage is present in any unknown circuit before measuring.**

Users of this product must be protected from electric shock at all times. The responsible body must ensure that users are prevented access and/or insulated from every connection point. In some cases, connections must be exposed to potential human contact. Product users in these circumstances must be trained to protect themselves from the risk of electric shock. If the circuit is capable of operating at or above 1000 volts, **no conductive part of the circuit may be exposed.**

As described in the International Electrotechnical Commission (IEC) Standard IEC 664, digital multimeter measuring circuits (e.g., Keithley Models 175A, 199, 2000, 2001, 2002, and 2010) are Installation Category II. All other instruments' signal terminals are Installation Category I and must not be connected to mains.

Do not connect switching cards directly to unlimited power circuits. They are intended to be used with impedance limited sources. NEVER connect switching cards directly to AC mains. When connecting sources to switching cards, install protective devices to limit fault current and voltage to the card.

Before operating an instrument, make sure the line cord is connected to a properly grounded power receptacle. Inspect the connecting cables, test leads, and jumpers for possible wear, cracks, or breaks before each use.

For maximum safety, do not touch the product, test cables, or any other instruments while power is applied to the circuit under test. ALWAYS remove power from the entire test system and discharge any capacitors before: connecting or disconnecting cables or jumpers, installing or removing switching cards, or making internal changes, such as installing or removing jumpers.

Do not touch any object that could provide a current path to the common side of the circuit under test or power line (earth) ground. Always make measurements with dry hands while standing on a dry, insulated surface capable of withstanding the voltage being measured.

---

The instrument and accessories must be used in accordance with its specifications and operating instructions or the safety of the equipment may be impaired.

Do not exceed the maximum signal levels of the instruments and accessories, as defined in the specifications and operating information, and as shown on the instrument or test fixture panels, or switching card.

When fuses are used in a product, replace with same type and rating for continued protection against fire hazard.

Chassis connections must only be used as shield connections for measuring circuits, **NOT** as safety earth ground connections.

If you are using a test fixture, keep the lid closed while power is applied to the device under test. Safe operation requires the use of a lid interlock.

If a  screw is present, connect it to safety earth ground using the wire recommended in the user documentation.

The  symbol on an instrument indicates that the user should refer to the operating instructions located in the manual.

The  symbol on an instrument shows that it can source or measure 1000 volts or more, including the combined effect of normal and common mode voltages. Use standard safety precautions to avoid personal contact with these voltages.

The **WARNING** heading in a manual explains dangers that might result in personal injury or death. Always read the associated information very carefully before performing the indicated procedure.

The **CAUTION** heading in a manual explains hazards that could damage the instrument. Such damage may invalidate the warranty.

Instrumentation and accessories shall not be connected to humans.

Before performing any maintenance, disconnect the line cord and all test cables.

To maintain protection from electric shock and fire, replacement components in mains circuits, including the power transformer, test leads, and input jacks, must be purchased from Keithley Instruments. Standard fuses, with applicable national safety approvals, may be used if the rating and type are the same. Other components that are not safety related may be purchased from other suppliers as long as they are equivalent to the original component. (Note that selected parts should be purchased only through Keithley Instruments to maintain accuracy and functionality of the product.) If you are unsure about the applicability of a replacement component, call a Keithley Instruments office for information.

To clean an instrument, use a damp cloth or mild, water based cleaner. Clean the exterior of the instrument only. Do not apply cleaner directly to the instrument or allow liquids to enter or spill on the instrument. Products that consist of a circuit board with no case or chassis (e.g., data acquisition board for installation into a computer) should never require cleaning if handled according to instructions. If the board becomes contaminated and operation is affected, the board should be returned to the factory for proper cleaning/servicing.

Rev. 2/99

---

# Table of Contents

## 1 Performance Verification

Introduction .....	1-2
Verification test requirements.....	1-3
Performing the verification test procedure.....	1-6
Verifying DC voltage .....	1-7
Verifying AC voltage.....	1-8
Verifying DC current.....	1-10
Verifying AC current .....	1-11
Verifying resistance.....	1-12
Verifying temperature .....	1-14
Verifying frequency.....	1-17
Verifying ratio .....	1-18

## 2 Calibration

Introduction .....	2-2
Environmental conditions .....	2-3
Calibration considerations.....	2-4
Calibration code .....	2-5
Comprehensive calibration.....	2-6
Front panel calibration .....	2-8
Remote calibration .....	2-16
Manufacturing calibration.....	2-24

## 3 Routine Maintenance

Introduction .....	3-2
Setting the line voltage and replacing the line fuse.....	3-2
Replacing the AMPS fuse .....	3-4

## 4 Troubleshooting

Introduction .....	4-2
Repair considerations .....	4-2
Power-on self-test.....	4-2
Front panel tests .....	4-3
Principles of operation .....	4-4
Troubleshooting .....	4-10
Analog signal switching states.....	4-13
No comm link error .....	4-18

---

## 5 Disassembly

Introduction .....	5-2
Handling and cleaning.....	5-2
Static sensitive devices .....	5-3
Assembly drawings .....	5-4
Case cover removal .....	5-5
Changing trigger link lines .....	5-6
Motherboard removal .....	5-7
Front panel disassembly .....	5-8
Main CPU firmware replacement.....	5-9
Removing power components .....	5-10
Instrument re-assembly .....	5-12

## 6 Replaceable Parts

Introduction .....	6-2
Parts lists.....	6-2
Ordering information.....	6-2
Factory service .....	6-3
Component layouts.....	6-3

## A Specifications

Accuracy calculations.....	A-7
----------------------------	-----

## B Calibration Command Reference

Introduction .....	B-2
Command summary .....	B-2
Miscellaneous calibration commands .....	B-4
DC calibration commands .....	B-8
AC calibration commands .....	B-14
Manufacturing calibration commands.....	B-16
Remote error reporting .....	B-18
Detecting calibration step completion.....	B-21

## C Calibration Program

Introduction .....	C-2
Computer hardware requirements .....	C-2
Software requirements.....	C-2
Calibration equipment .....	C-3
General program instructions .....	C-3



---

## List of Illustrations

### 1 Performance Verification

Connections for DC volts verification.....	1-7
Connections for AC volts verification .....	1-8
Connections for DC current verification .....	1-10
Connections for AC current verification .....	1-11
Connections for resistance verification (10 $\Omega$ -10M $\Omega$ ranges).....	1-12
Connections for resistance verification (100M $\Omega$ range).....	1-13
Connections for frequency verification.....	1-17
Verifying ratio .....	1-18

### 2 Calibration

Low-thermal short connections.....	2-9
Calibrator connections for DC volts and ohms portion of comprehensive calibration .....	2-10
Connections for DC and AC amps comprehensive calibration.....	2-12
Connections for AC volts calibration .....	2-13
Synthesizer connections for manufacturing calibration.....	2-25

### 3 Routine Maintenance

Power module.....	3-3
-------------------	-----

### 4 Troubleshooting

Power supply block diagram .....	4-5
Digital circuitry block diagram .....	4-7
Analog circuitry block diagram .....	4-8

### 5 Disassembly

Trigger link connectors .....	5-6
-------------------------------	-----

---

## List of Tables

### 1 Performance Verification

Recommended verification equipment .....	1-4
DCV reading limits .....	1-7
ACV reading limits.....	1-9
DCI limits .....	1-10
ACI limits .....	1-11
Limits for resistance verification .....	1-13
Thermocouple temperature verification reading limits .....	1-15
Four-wire RTD temperature verification reading limits .....	1-16

### 2 Calibration

Recommended equipment for comprehensive, DC-only, or AC-only calibration .....	2-6
Comprehensive calibration procedures .....	2-8
DC volts calibration summary.....	2-11
Ohms calibration summary .....	2-11
DC current calibration summary .....	2-12
AC voltage calibration summary .....	2-13
AC current calibration summary .....	2-14
DC voltage calibration programming steps.....	2-18
Resistance calibration programming steps.....	2-19
DC current calibration programming steps .....	2-20
AC voltage calibration programming steps .....	2-21
AC current calibration programming steps .....	2-22
Recommended equipment for manufacturing calibration .....	2-24

### 3 Routine Maintenance

Power line fuse .....	3-3
-----------------------	-----

### 4 Troubleshooting

Power supply components.....	4-4
Display board checks .....	4-10
Power supply checks .....	4-11
Digital circuitry checks .....	4-12
DCV signal switching .....	4-13
ACV and FREQ signal switching.....	4-13
$\Omega 2$ signal switching.....	4-14
$\Omega 4$ signal switching.....	4-14
$\Omega 2/\Omega 4$ reference switching .....	4-15
DCA signal switching .....	4-15

---

ACA signal switching .....	4-15
DCV signal multiplexing and gain .....	4-16
ACV and ACA signal multiplexing and gain.....	4-16
DCA signal multiplexing and gain .....	4-16
$\Omega$ 2 signal multiplexing and gain.....	4-17
$\Omega$ 4 signal multiplexing and gain.....	4-17
Circuit section locations for switching devices .....	4-17

## **6 Replaceable Parts**

Mother board parts list .....	6-4
Display board parts list .....	6-11
Connector board parts list .....	6-11
Mechanical parts list.....	6-12

## **B Calibration Command Reference**

Remote calibration command summary .....	B-2
DC calibration commands .....	B-8
AC calibration commands .....	B-14
Calibration error summary.....	B-18



# 1 Performance Verification

## Introduction

Use the procedures in this section to verify that the Model 2010 Multimeter accuracy is within the limits stated in the instrument's one-year accuracy specifications. You can perform verification procedures:

- When you first receive the instrument to make sure that it was not damaged during shipment, and that the unit meets factory specifications.
- If the instrument's accuracy is questionable.
- Following calibration.

**WARNING** *The information in this section is intended only for qualified service personnel. Do not attempt these procedures unless you are qualified to do so.*

**NOTE** *If the instrument is still under warranty and its performance is outside specified limits, contact your Keithley representative or the factory to determine the correct course of action.*

## Verification test requirements

Be sure that you perform the verification tests:

- Under the proper environmental conditions.
- After the specified warm-up period.
- Using the correct line voltage.
- Using the proper calibration equipment.
- Using the specified reading limits.

### Environmental conditions

Conduct your performance verification procedures in a test environment that has:

- An ambient temperature of 18-28°C (65-82°F).
- A relative humidity of less than 80% unless otherwise noted.

### Warm-up period

Allow the Model 2010 Multimeter to warm up for at least two hours before conducting the verification procedures.

If the instrument has been subjected to temperature extremes (those outside the ranges stated above), allow additional time for the instrument's internal temperature to stabilize. Typically, allow one extra hour to stabilize a unit that is 10°C (18°F) outside the specified temperature range.

Also, allow the test equipment to warm up for the minimum time specified by the manufacturer.

### Line power

The Model 2010 Multimeter requires a line voltage of 100V/120V/220V/240V, ±10% and a line frequency of 45Hz to 66Hz and 360Hz to 440Hz.

## Recommended test equipment

Table 1-1 summarizes recommended verification equipment. Use the Fluke Model 5700A Calibrator (or the equivalent) to verify Model 2010 Multimeter measurement accuracy. You can use alternate equipment as long as that equipment has specifications at least as good as those listed in Table 1-1. Keep in mind, however, that the calibrator will add to the uncertainty of each measurement. Table 1-1 lists the uncertainties of the recommended Fluke 5700A at each source value.

**Table 1-1**  
Recommended verification equipment

<b>Fluke 5700A Calibrator:</b>				
<b>DC voltage</b>	<b>AC voltage (1kHz, 50kHz)*</b>	<b>DC current</b>	<b>AC current (1kHz)</b>	<b>Resistance</b>
100mV:±14ppm 1.0V:±7ppm 10V:±5ppm 100V:±7ppm 1000V:±9ppm	100mV:±200ppm 1.0V:±82ppm 10V:±82ppm 100V:±90ppm 700V:±85ppm	10mA:±60ppm 100mA:±70ppm 1A:±110ppm 2.2A:±94ppm	1A:±690ppm 2.2A:±682ppm	10Ω:±28ppm 100Ω:±17ppm 1kΩ:±12ppm 10kΩ:±11ppm 100kΩ:±13ppm 1MΩ:±18ppm 10MΩ:±37ppm 100MΩ:±120ppm
<b>Fluke 5725A Amplifier:</b> AC Voltage, 50kHz: 700V, ±375ppm				
<b>Keithley 3930A or 3940 Frequency Synthesizer:</b> 1V RMS, 1kHz, ±5ppm				
<b>General Radio 1433-T Precision Decade Resistance Box:</b> 10Ω-400Ω, ±0.02%				

\*1kHz specifications shown. 5725A amplifier required to source 700V at 50kHz.

NOTE: The Fluke 5725A amplifier is necessary only if you wish to verify the 750V AC range at 50kHz. Verification at 220V, 50kHz using only the 5700A calibrator is adequate for most applications.

## Verification limits

The verification limits stated in this section have been calculated using only the Model 2010 one-year accuracy specifications. All ranges do not include the verification equipment's uncertainty. If a particular measurement falls slightly outside the allowable range, recalculate new limits based on both Model 2010 specifications and pertinent calibration equipment specifications.

### Example reading limit calculation

The following is an example of how reading limits have been calculated:

Assume you are testing the 10V DC range using a 10V input value. Using the Model 2010 one-year accuracy specification for 10V DC of  $\pm$  (24ppm of reading + 4ppm of range), the calculated limits are:

$$\text{Reading limits} = 10V \pm [(10V \times 24\text{ppm}) + (10V \times 4\text{ppm})]$$

$$\text{Reading limits} = 10V \pm (.00024 + .00004)$$

$$\text{Reading limits} = 10V \pm .00028V$$

$$\text{Reading limits} = 9.99972V \text{ to } 10.00028V$$

### Calculating resistance reading limits

Resistance reading limits must be recalculated based on the actual calibration resistance values supplied by the equipment manufacturer. Calculations are performed in the same manner as shown in the preceding example, except you should use the actual calibration resistance values instead of the nominal values when performing your calculations.

## Restoring factory defaults

Before performing the verification procedures, restore the instrument to its factory defaults as follows:

1. Press SHIFT and then SETUP. The instrument will display the following prompt:  
RESTORE: FACT

**NOTE** Pressing either range key toggles the RESTORE selection between USER and FACT.

2. Select FACT, and then restore the factory default conditions by pressing ENTER.
3. Factory defaults will be set as follows:  
Speed: medium  
Filter: 10 readings



## Performing the verification test procedures

### Test summary

Verification test procedures include:

- DC volts
- AC volts
- DC current
- AC current
- Resistance
- Temperature
- Frequency
- Ratio

If the Model 2010 is not within specifications and not under warranty, see the calibration procedures in Section 2.

### Test considerations

When performing the verification procedures:

- Be sure to restore factory defaults as outlined above.
- Restore factory defaults and choose the measurement function to be tested.
- Make sure that the equipment is properly warmed up and connected to the front panel input jacks. Also make sure that the front panel input jacks are selected with the INPUTS switch.
- Do not use autoranging for any verification tests because autorange hysteresis may cause the Model 2010 to be on an incorrect range. For each test signal, you must manually set the correct range for the Model 2010 using the range keys.
- Make sure the calibrator is in operate before you verify each measurement.
- Always let the source signal settle before taking a reading.
- Do not connect test equipment to the Model 2010 through a scanner or other switching equipment.

**WARNING** *The maximum common-mode voltage (voltage between INPUT LO and chassis ground) is 500V peak. Exceeding this value may cause a breakdown in insulation, creating a shock hazard. Some of the procedures in this section may expose you to dangerous voltages. Use standard safety precautions when such dangerous voltages are encountered to avoid personal injury caused by electric shock.*

## Verifying DC voltage

Check DC voltage accuracy by applying accurate voltages from the DC voltage calibrator to the Model 2010 INPUT jacks and verifying that the displayed readings fall within specified limits. Follow these steps to verify the DC voltage:

**CAUTION** Do not exceed 1000V peak between INPUT HI and INPUT LO because instrument damage may occur.

1. Connect the Model 2010 HI and LO INPUT jacks to the DC voltage calibrator as shown in Figure 1-1.

**NOTE** Use shielded, low-thermal connections when testing the 100mV and 1V ranges to avoid errors caused by noise or thermal effects. Connect the shield to the calibrator's output LO terminal.

**Figure 1-1**  
Connections for  
DC volts verification

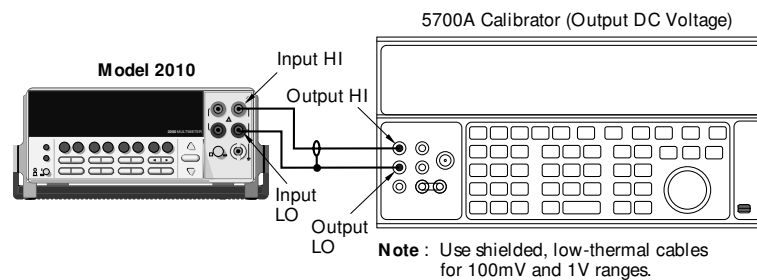

2. Select the DC volts function by pressing the DCV key, and set the Model 2010 to the 100mV range.
3. Set the calibrator output to 0.00000mV DC, and allow the reading to settle.
4. Enable the Model 2010 REL mode. Leave REL enabled for the remainder of the DC volts verification tests.
5. Source positive and negative full-scale voltages for each of the ranges listed in Table 1-2. For each voltage setting, be sure that the reading is within stated limits.

**Table 1-2**  
DCV reading limits

Range	Applied DC voltage*	Reading limits (1 year, 18°C–28°C)
100mV	100.0000mV	99.99540 to 100.00460mV
1V	1.000000V	0.9999730 to 1.0000270V
10V	10.00000V	9.999720 to 10.000280V
100V	100.0000V	99.99600 to 100.00400V
1000V	1000.000V	999.9530 to 1000.0470V

\* Source positive and negative values for each range.

## Verifying AC voltage

Check AC voltage accuracy by applying accurate AC voltages at specific frequencies from the AC voltage calibrator to the Model 2010 inputs and verifying that the displayed readings fall within specified ranges.

**CAUTION** Do not exceed 1000V peak between INPUT HI and INPUT LO, or  $8 \times 10^7$  V•Hz input, because instrument damage may occur.

Follow these steps to verify AC voltage accuracy:

1. Connect the Model 2010 HI and LO INPUT jacks to the AC voltage calibrator as shown in Figure 1-2.

**Figure 1-2**  
Connections for  
AC volts verification

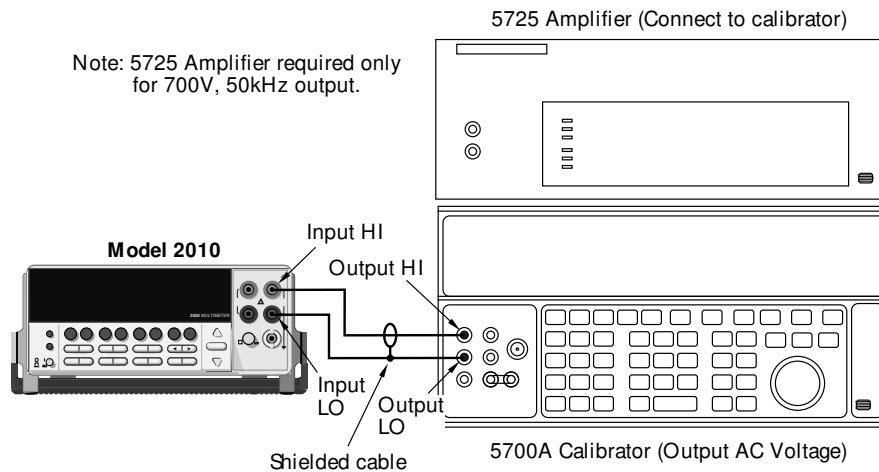

2. Select the AC volts function by pressing the ACV key.
3. Set the Model 2010 for the 100mV range; make sure that REL is disabled.
4. Source 1kHz and 50kHz AC voltages for each of the ranges summarized in Table 1-3, and make sure that the respective Model 2010 readings fall within stated limits.

**Table 1-3**  
ACV reading limits

ACV range	Applied AC voltage	Reading limits (1 year, 18°C–28°C)	
		1kHz	50kHz
100mV	100.0000mV	99.910 to 100.090mV	99.830 to 100.170mV
1V	1.000000V	0.99910 to 1.00090V	0.99830 to 1.00170V
10V	10.00000V	9.9910 to 10.0090V	9.98300 to 10.0170V
100V	100.0000V	99.910 to 100.090V	99.830 to 100.170V
750V	700.000V*	699.36 to 700.64V	698.79 to 701.21V

\*If the 5725A amplifier is not available, change the 700V at 50kHz step to 220V at 50kHz.  
(Reading limits for 220V at 50kHz = 219.361 to 220.639V).

## Verifying DC current

Check DC current accuracy by applying accurate DC currents from the DC current calibrator to the AMPS input of the Model 2010 and verifying that the displayed readings fall within specified limits. Follow these steps to verify DC current accuracy:

1. Connect the Model 2010 AMPS and INPUT LO jacks to the calibrator as shown in Figure 1-3.
2. Select the DC current measurement function by pressing the DCI key.
3. Set the Model 2010 for the 10mA range.
4. Source positive and negative full-scale currents for each of the ranges listed in Table 1-4, and verify that the readings for each range are within stated limits.

**Figure 1-3**  
Connections for  
DC current verification

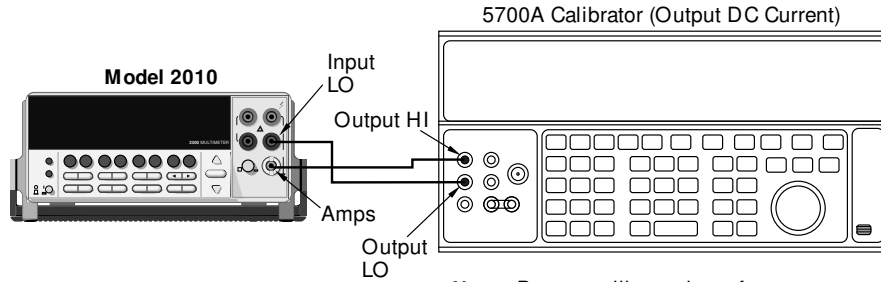

**Note:** Be sure calibrator is set for normal current output.

**Table 1-4**  
DCI limits

DCI range	Applied DC current*	Reading limits (1 year, 18°C–28°C)
10mA	10.0000mA	9.994600 to 10.005400mA
100mA	100.0000mA	99.94600 to 100.05400mA
1A	1.000000A	0.9991600 to 1.0008400A
3A	2.20000A	2.197315 to 2.202685A

\*Source positive and negative currents with values shown.

## Verifying AC current

Check AC current accuracy by applying accurate AC current at specific frequencies from the AC current calibrator to the Model 2010 input and verifying that the displayed readings fall within specified limits. Follow these steps to verify AC current:

1. Connect the Model 2010 AMPS and INPUT LO jacks to the calibrator as shown in Figure 1-4.
2. Select the AC current function by pressing the ACI key.
3. Set the Model 2010 for the 1A range.
4. Source 1A and 2.2A, 1kHz full-scale AC currents as summarized in Table 1-5, and verify that the readings are within stated limits.

**Figure 1-4**  
Connections for  
AC current verification

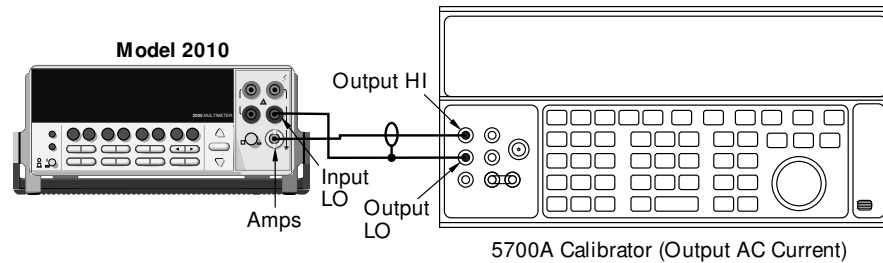

**Table 1-5**  
ACI limits

ACI range	Applied DC voltage	Reading limits (1 year, 18°C–28°C) 1kHz
1A	1.000000A	0.99860 to 1.00140A
3A	2.20000A	2.1949 to 2.2051A

## Verifying resistance

Check resistance by connecting accurate resistance values to the Model 2010 and verifying that its resistance readings are within the specified limits.

**CAUTION** Do not apply more 1000V peak between INPUT HI and LO or more than 350V peak between SENSE HI and LO, or instrument damage could occur.

Follow these steps to verify resistance accuracy:

1. Using shielded 4-wire connections, connect the Model 2010 INPUT and SENSE jacks to the calibrator as shown in Figure 1-5.

**Figure 1-5**  
Connections for  
resistance verification  
(10 $\Omega$ -  
10M $\Omega$  ranges)

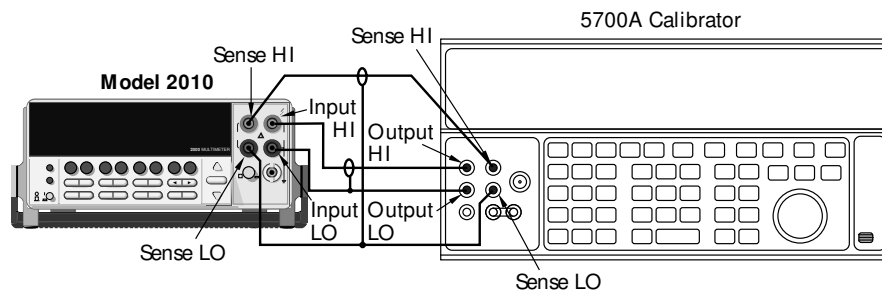

**Note :** Use shielded low-thermal cables to minimize noise. Enable or disable calibrator external sense as indicated in procedure.

2. Set the calibrator for 4-wire resistance with external sense on.
3. Select the Model 2010 4-wire resistance function by pressing the  $\Omega 4$  key.
4. Set the Model 2010 for the 10 $\Omega$  range, and make sure the FILTER is on. Set the calibrator output to 0 $\Omega$ , then enable Model 2010 REL.
5. Recalculate reading limits based on actual calibrator resistance values.
6. Source the nominal full-scale resistance values for the 10 $\Omega$ -10M $\Omega$  ranges summarized in Table 1-6, and verify that the readings are within calculated limits.
7. Connect the Model 2010 INPUT and SENSE jacks to the calibrator as shown in Figure 1-6.
8. Disable external sense on the calibrator.
9. Set the Model 2010 for the 100M $\Omega$  range.
10. Source a nominal 100M $\Omega$  resistance value, and verify that the reading is within calculated limits for the 100M $\Omega$  range.

**Table 1-6**  
Limits for resistance verification

$\Omega$ range	Nominal applied resistance	Nominal reading limits (1 year, 18°C–28°C)	Recalculated limits*
10 $\Omega$	10 $\Omega$	9.999310 to 10.000690 $\Omega$	_____ to _____ $\Omega$
100 $\Omega$	100 $\Omega$	99.99390 to 100.00610 $\Omega$	_____ to _____ $\Omega$
1k $\Omega$	1k $\Omega$	0.9999480 to 1.0000520k $\Omega$	_____ to _____ k $\Omega$
10k $\Omega$	10k $\Omega$	9.999480 to 10.000520k $\Omega$	_____ to _____ k $\Omega$
100k $\Omega$	100k $\Omega$	99.99080 to 100.00920k $\Omega$	_____ to _____ k $\Omega$
1M $\Omega$	1M $\Omega$	0.9999260 to 1.0000740M $\Omega$	_____ to _____ M $\Omega$
10M $\Omega$	10M $\Omega$	9.995960 to 10.004040M $\Omega$	_____ to _____ M $\Omega$
100M $\Omega$	100M $\Omega$	99.84960 to 100.15040M $\Omega$	_____ to _____ M $\Omega$

\* See verification limits.

**Figure 1-6**  
Connections for resistance verification (100M $\Omega$  range)

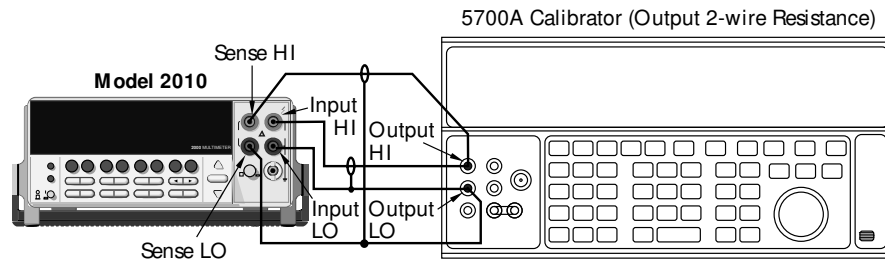

**Note :** Use shielded cables to minimize noise.  
Disable calibrator external sense mode.



## Verifying temperature

Thermocouple and RTD temperature readings are derived from DC volts and ohms readings respectively. For this reason, it is not necessary to independently verify the accuracy of temperature measurements. As long as the DC volts and ohms functions meet or exceed their respective specifications, temperature function accuracy is automatically verified. However, temperature verification procedures are provided below for those who wish to separately verify temperature accuracy.

### Thermocouple temperature

1. Connect the DC voltage calibrator output terminals to the Model 2010 INPUT jacks using low-thermal shielded connections. (Use 2-wire connections similar to those shown in Figure 1-1.)
2. Configure the Model 2010 for °C units, type J temperature sensor, and 0°C simulated reference junction as follows:
  - A. Press SHIFT then SENSOR, and note the unit displays the temperature units: UNITS: C. (If necessary, use the cursor and range keys to select °C units.)
  - B. Press ENTER, and note the unit displays the sensor type: SENS: TCOUPLE. (Use the cursor and range keys to select a thermocouple type temperature sensor.)
  - C. Press ENTER. The unit then displays the thermocouple type: TYPE: J.
  - D. Select a type J temperature sensor, and then press ENTER. The unit displays the reference junction type: JUNC: SIM.
  - E. Make sure the simulated reference junction type is selected, and then press ENTER. The unit displays the current simulated reference junction temperature: SIM: 023.
  - F. Using the cursor and range keys, set the reference junction temperature to 0°C, and then press ENTER to complete the temperature configuration process.

3. Select the temperature function by pressing the TEMP key.
4. Source each of the voltages summarized in Table 1-7, and verify that the temperature readings are within limits. Be sure to select the appropriate thermocouple type for each group of readings. (See step 2.)

**Table 1-7***Thermocouple temperature verification reading limits*

<b>Thermocouple type</b>	<b>Applied DC voltage*</b>	<b>Reading limits (1 year, 18°C–28°C)</b>
J	-7.659mV	-190.60 to -189.40°C
	0mV	-0.50 to +0.50°C
K	42.281mV	749.50 to 750.50°C
	-5.730mV	-190.60 to -189.40°C
	0mV	-0.50 to +0.50°C
	54.138mV	1349.20 to 1350.80°C

\* Voltages shown are based on ITS-90 standard using 0°C reference junction temperature. See text for procedure to set reference junction temperature.

## RTD temperature

1. Connect the precision decade resistance box (listed in Table 1-1) to the Model 2010 INPUT and SENSE jacks using 4-wire connections. (See Figure 1-1 for a similar connecting scheme.)
2. Configure the Model 2010 temperature function for °C units and RTD temperature sensor ( $\alpha=0.00385$ ) as follows:
  - A. Press SHIFT then SENSOR, and note the unit displays the temperature units: UNITS: C.
  - B. Press ENTER, and note the unit displays the sensor type: SENS: TCOUPLE.
  - C. Using the cursor and range keys, set the display as follows: SENS: 4W-RTD.
  - D. Press ENTER, and note the unit displays: TYPE: PT100.
  - E. Using the cursor and range keys, set the unit for the following display: TYPE: PT385.
  - F. Press ENTER to complete the temperature configuration process.
3. Select the temperature function by pressing the TEMP key.
4. Set the decade resistance box to each of the values shown in Table 1-8, and verify that the temperature readings are within the required limits.

**Table 1-8**

*Four-wire RTD temperature verification reading limits*

Applied resistance*	Reading limits (°C) (1 year, 18°C–28°C)
22.80Ω	-190.14 to -189.86°C
100.00Ω	-0.08 to +0.08°C
313.59Ω	599.86 to 600.14°C

\* Based on  $\alpha = 0.00385$ . See text.

## Verifying frequency

Follow the steps below to verify the Model 2010 frequency function.

1. Connect the frequency synthesizer to the Model 2010 INPUT jacks. See Figure 1-7.
2. Set the synthesizer to output a 1kHz, 1V RMS sine wave.
3. Select the Model 2010 frequency function by pressing the **FREQ** key.
4. Verify that the Model 2010 frequency reading is between 999.9000Hz and 1.000100kHz.

**Figure 1-7**  
*Connections for  
frequency verifi-  
cation*

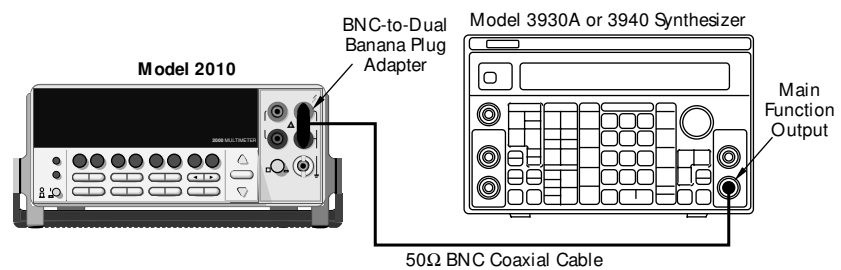

## Verifying ratio

**CAUTION** When verifying ratio or using sense volts, the SENSE LO terminal must be referenced to INPUT LO. Exceeding 350V DC from SENSE HI to SENSE LO will cause instrument damage.

1. Connect SENSE HI to INPUT HI, and connect SENSE LO to INPUT LO.
2. Connect the DC calibrator output HI and LO terminals to the Model 2010 HI and LO terminals respectively, as shown in Figure 1-8.
3. Select the Model 2010 DCV function, and select the 1V range.
4. Set the DC calibrator output to +1.000000V DC, and turn on its output.
5. Press SHIFT then RATIO, then select and enable both RATIO:ON and SENSEIN:ON.
6. Verify that the ratio reading is between 0.9999460 and 1.0000540.

**Figure 1-8**  
Verifying ratio

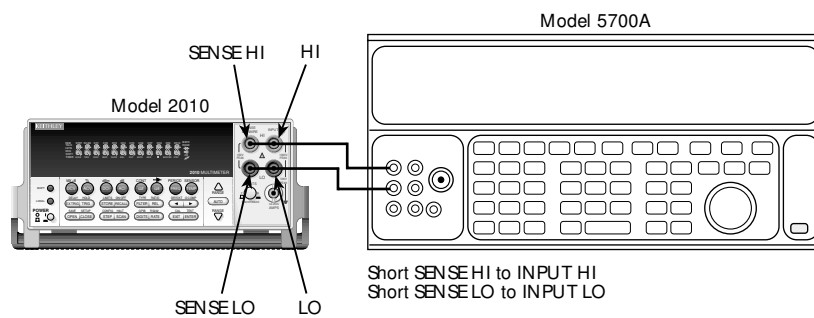

---

# 2 Calibration

## Introduction

Use the procedures in this section to calibrate the Model 2010. Calibration procedures include:

- Comprehensive calibration: calibrate DC and AC voltages, DC and AC currents, and resistance values.
- Manufacturing calibration: usually only performed at the factory

**WARNING** *The information in this section is intended for qualified service personnel only. Do not attempt these procedures unless you are qualified to do so.*

All the procedures require accurate calibration equipment to supply precise DC and AC voltages, DC and AC currents, and resistance values. Comprehensive AC and DC calibration can be performed any time by an operator either from the front panel, or by using the SCPI commands sent either over the IEEE-488 bus or the RS-232 port. DC-only and AC-only calibration may be performed individually, if desired.

**NOTE** *Manufacturing calibration is normally required in the field only if the Model 2010 has been repaired.*

## Environmental conditions

Conduct the calibration procedures in a location that has:

- An ambient temperature of 18-28°C (65-82°F)
- A relative humidity of less than 80% unless otherwise noted

### Warm-up period

Allow the Model 2010 Multimeter to warm up for at least two hours before performing calibration.

If the instrument has been subjected to temperature extremes (those outside the ranges stated in the above section), allow extra time for the instrument's internal temperature to stabilize. Typically, allow one extra hour to stabilize a unit that is 10°C (18°F) outside the specified temperature range.

Also, allow the test equipment to warm up for the minimum time specified by the manufacturer.

### Line power

The Model 2010 Multimeter requires a line voltage of 100V/120V/220V/240V,  $\pm 10\%$  and a line frequency of 45Hz to 66Hz, or 360Hz to 440Hz.



## Calibration considerations

When performing the calibration procedures:

- Make sure that the equipment is properly warmed up and connected to the appropriate input jacks. Also make sure that the correct input jacks are selected with the INPUTS switch.
- Make sure the calibrator is in operate before you complete each calibration step.
- Always let the source signal settle before calibrating each point.
- Do not connect test equipment to the Model 2010 through a scanner or other switching equipment.
- If an error occurs during calibration, the Model 2010 will generate an appropriate error message. See Appendix B for more information.
- Always allow the calibrator to settle before pressing ENTER to complete each step. (There is a “u” on the display of the 5700A Calibrator that is the settle annunciator).

**WARNING** *The maximum common-mode voltage (voltage between INPUT LO and chassis ground) is 500V peak. Exceeding this value may cause a breakdown in insulation, creating a shock hazard. Some of the procedures in this section may expose you to dangerous voltages. Use standard safety precautions when such dangerous voltages are encountered to avoid personal injury caused by electric shock.*

## Calibration code

Before performing comprehensive calibration, you must first unlock calibration by entering the appropriate calibration code.

### Front panel code

For front panel calibration, follow these steps:

1. Access the calibration menu by pressing **SHIFT CAL**, and note that the instrument displays the following:

CAL: DATES

2. Use the up or down range key to scroll through the available calibration parameters until the unit displays **RUN**, and then press **ENTER**.
3. The Model 2010 then prompts you to enter a code:

CODE? 000000

The factory default code is 002010. Use the left and right arrow keys to move among the digits, use the up range key to increment numbers, and press the down range key to specify alphabetic letters. Confirm the code by pressing **ENTER**.

4. The Model 2010 lets you define a new calibration code. Use the up and down range keys to toggle between yes and no. Choose **N** if you do not want to change the code. Choose **Y** if you want to change the code. The unit then prompts you to enter a new code. Enter the code, and press **ENTER**.

### Remote command code

If you are performing calibration over the IEEE-488 bus or the RS-232 port, send the following command to unlock calibration:

```
CAL:PROT:CODE '<8-character string>'
```

The default code command is:

```
CAL:PROT:CODE 'KI002010'
```

**NOTE** *If the first two characters are anything other than “KI”, you will not be able to unlock cal from the front panel.*

## Comprehensive calibration

The comprehensive calibration procedure calibrates the DCV, DCI, ACV, ACI, and ohms functions. You can also choose to calibrate only the DCV/DCI and resistance, or the ACV/ACI functions.

These procedures are usually the only ones required in the field. Manufacturing calibration is done at the factory and can be done in the field if the unit has been repaired. See Manufacturing calibration at the end of this section for more information.

### Calibration cycle

Perform comprehensive calibration at least every other year, once a year, or every 90 days to ensure the unit meets the corresponding specifications.

### Recommended equipment

Table 2-1 lists the recommended equipment you need for comprehensive, DC only, and AC only calibration procedures. You can use alternate equipment, such as a DC transfer standard and characterized resistors, as long as that equipment has specifications at least as good as those listed in the table.

**Table 2-1**

*Recommended equipment for comprehensive, DC-only, or AC-only calibration*

<b>Fluke 5700A calibrator:</b>				
<b>DC voltage</b>	<b>AC voltage (1kHz, 50kHz)*</b>	<b>DC current</b>	<b>AC current (1kHz)</b>	<b>Resistance</b>
±10V:±5ppm 100V:±7ppm	10mV:±710ppm 100mV:±200ppm 1.0V:±82ppm 10V:±82ppm 100V:±90ppm 700V:±85ppm	10mA:±60ppm 100mA:±70ppm 1A:±110ppm	100mA:±190ppm 1A:±690ppm 2A:±670ppm	10Ω:±28ppm 1kΩ:±12ppm 10kΩ:±11ppm 100kΩ:±13ppm 1MΩ:±18ppm
<b>Keithley 8610 Low-thermal shorting plug</b>				

\* 1kHz specifications. 10mV and 700V points require 1kHz only. All calibrator specifications are 90-day, 23°C ±5°C specifications and indicate total absolute uncertainty at specified output.

## Aborting calibration

You can abort the front panel calibration process at any time by pressing EXIT. The instrument will then ask you to confirm your decision to abort with the following message:

ABORT CAL?

Press EXIT to abort calibration at this point, or press any other key to return to the calibration process.

**NOTE** *The Model 2010 will not respond to any remote programming commands while the ABORT CAL? message is displayed.*

## Front panel calibration

Use the following steps for comprehensive, DC-only, and AC-only calibration procedures.

The procedures for front panel calibration include:

- Preparing the Model 2010 for calibration
- Front panel short and open calibration
- DC voltage calibration
- Resistance calibration
- DC current calibration
- AC voltage calibration
- AC current calibration
- Setting calibration dates

### Preparing the Model 2010 for calibration

1. Turn on the Model 2010, and allow it to warm up for at least two hours before performing calibration procedure.
2. Start the calibration process as follows:
  - A. Access the calibration menu by pressing SHIFT then CAL.
  - B. Use the up and down range keys to scroll through the available calibration menu items until the unit displays RUN, and then press ENTER.
  - C. At the prompt, enter the calibration code. (The default code is 002010.) Use the left and right arrow keys to move among the digits, use the up range key to increment numbers, and press the down range key to specify alphabetic letters. Confirm the code by pressing ENTER.
  - D. Choose N at the prompt to proceed without changing the code, and then press ENTER.
3. Choose which of the calibration tests summarized in Table 2-2 you want to run at the CAL: RUN prompt. Use the up and down range keys to scroll through the options; select your choice by pressing ENTER.

**Table 2-2**  
*Comprehensive calibration procedures*

Procedure	Menu choice	Procedures
Full calibration	ALL	All comprehensive calibration steps.
DCV, DCI, and ohms	DC	DC voltage, DC current, and resistance calibration.
ACV and ACI	AC	AC voltage and AC current.

## Front panel short and open calibration

At the Model 2010 prompt for a front panel short, perform the following:

1. Connect the Model 8610 low-thermal short to the instrument front panel INPUT and SENSE terminals as shown in Figure 2-1. Make sure the INPUTS button is not pressed in so that the front inputs are selected. Wait at least three minutes before proceeding to allow for thermal equilibrium.

**NOTE** Be sure to connect the low-thermal short properly to the HI, LO, and SENSE terminals. Keep drafts away from low-thermal connections to avoid thermal drift, which could affect calibration accuracy.

**Figure 2-1**  
Low-thermal  
short connections

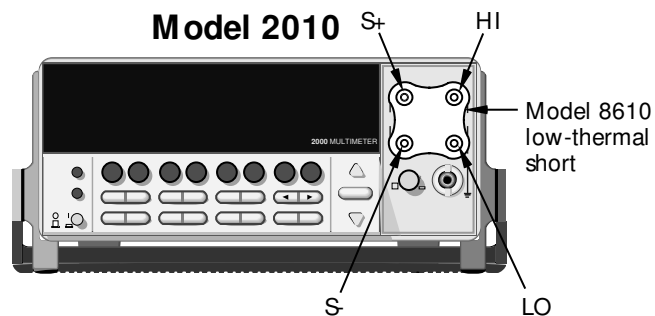

2. Press ENTER to start short-circuit calibration. While the unit is calibrating, the unit will display:  
CALIBRATING
3. When the unit is done calibrating, it will display the following prompt:  
OPEN CIRCUIT
4. Remove the calibration short, and press ENTER. During this phase, the CALIBRATING message will be displayed.

## DC volts calibration

After the front panel short and open procedure, the unit will prompt you for the first DC voltage: +10V. Perform the following:

1. Connect the calibrator to the Model 2010 as shown in Figure 2-2. Wait three minutes to allow for thermal equilibrium before proceeding.

**NOTE** Although 4-wire connections are shown, the sense leads are connected and disconnected at various points in this procedure by turning calibrator external sense on or off as appropriate. If your calibrator does not have provisions for turning external sense on and off, disconnect the sense leads when external sensing is to be turned off, and connect the sense leads when external sensing is to be turned on. Do not exceed  $\pm 15V$  peak on sense LO to LO. This will cause erroneous readings to be stored during calibration.

**Figure 2-2**  
Calibrator connections for DC volts and ohms portion of comprehensive calibration

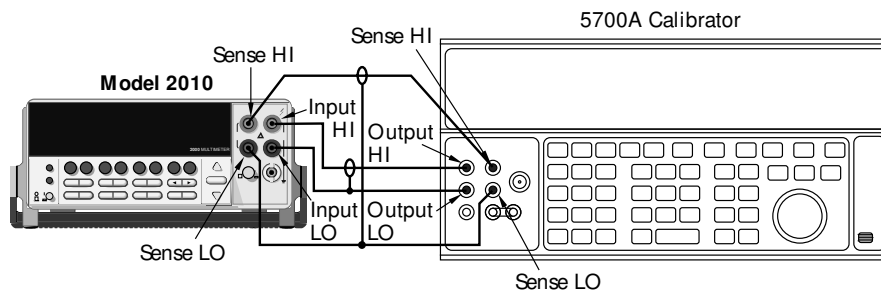

**Note :** Use shielded low-thermal cables to minimize noise. Enable or disable calibrator external sense as indicated in procedure.

2. Set the calibrator to output DC volts, and turn external sense off.
3. Perform the steps listed in Table 2-3 to complete DC volts calibration. For each calibration step:
  - Set the calibrator to the indicated value, and make sure it is in operate.
  - Press the ENTER key to calibrate that step.
  - Wait until the Model 2010 finishes each step. The unit will display the CALIBRATING message while calibrating.

**NOTE** If your calibrator cannot output the values recommended in Table 2-3, use the left and right arrow keys, and the up and down range keys to set the Model 2010 display value to match the calibrator output voltage.

**Table 2-3**  
DC volts calibration summary

Calibration step	Calibrator voltage	Allowable range
+10V	+10.00000V	+9V to +11V
-10V	-10.00000V	-9V to -11V
100V	+100.0000V	+90V to +110V

## Resistance calibration

Completing the 100V DC calibration step ends the DC voltage calibration procedure. The Model 2010 will then prompt you to connect 10 $\Omega$ . Follow these steps for resistance calibration:

1. Set the calibrator output for resistance, and turn on external sense.

**NOTE** Use external sense (4-wire  $\Omega$ ) when calibrating all resistance ranges. Be sure that the calibrator external sense mode is turned on.

2. Perform the calibration steps summarized in Table 2-4. For each step:
  - Set the calibrator to the indicated value, and place the unit in operate. (If the calibrator cannot output the exact resistance value, use the Model 2010 left and right arrow keys and the range keys to adjust the Model 2010 display to agree with the calibrator resistance.)
  - Press the ENTER key to calibrate each point.
  - Wait for the Model 2010 to complete each step before continuing.

**Table 2-4**  
Ohms calibration summary

Calibration step	Calibrator resistance*	Allowable range
10 $\Omega$	10 $\Omega$	9 $\Omega$ to 11 $\Omega$
1k $\Omega$	1k $\Omega$	0.9k $\Omega$ to 1.1k $\Omega$
10k $\Omega$	10k $\Omega$	9k $\Omega$ to 11k $\Omega$
100k $\Omega$	100k $\Omega$	90k $\Omega$ to 110k $\Omega$
1M $\Omega$	1M $\Omega$	0.9M $\Omega$ to 1.1M $\Omega$

\* Nominal resistance. Adjust Model 2010 calibration parameter to agree with actual value.



## DC current calibration

After the  $1M\Omega$  resistance point has been calibrated, the unit will prompt you for 10mA. Follow these steps for DC current calibration:

1. Connect the calibrator to the AMPS and INPUT LO terminals of the Model 2010 as shown in Figure 2-3.

**Figure 2-3**  
Connections for DC and AC amps comprehensive calibration

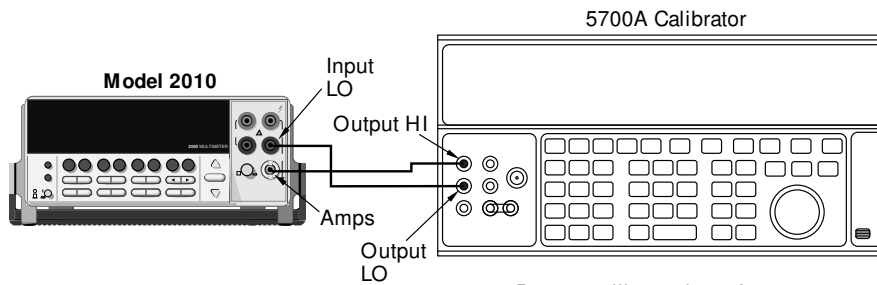

**Note:** Be sure calibrator is set for normal current output.

2. Calibrate each current step summarized in Table 2-5. For each step:
  - Set the calibrator to the indicated DC current, and make sure the unit is in operate.
  - Make sure the Model 2010 display indicates the correct calibration current.
  - Press ENTER to complete each step.
  - Allow the Model 2010 to finish each step.

**NOTE** If you are performing DC-only calibration, proceed to Setting calibration dates.

**Table 2-5**  
DC current calibration summary

Calibration step	Calibrator current	Allowable range
10mA	10.00000mA	9mA to 11mA
100mA	100.0000mA	90mA to 110mA
1A	1.000000A	0.9A to 1.1A

## AC voltage calibration

Follow these steps for AC voltage calibration:

1. Connect the calibrator to the Model 2010 INPUT HI and LO terminals as shown in Figure 2-4.

**Figure 2-4**  
Connections for  
AC volts calibration

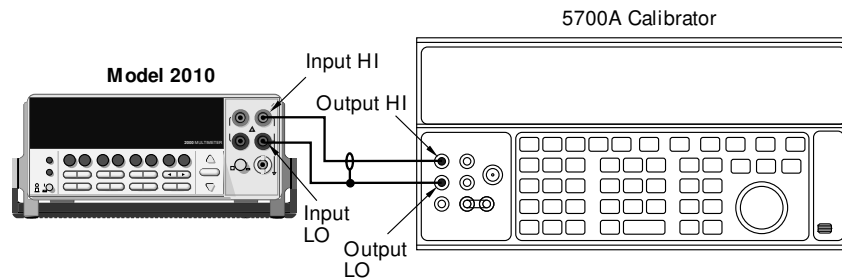

2. Perform the calibration steps summarized in Table 2-6. For each step:
  - Set the calibrator to the indicated value, and make sure the calibrator is in operate.
  - Press ENTER to complete each step.
  - Wait until the Model 2010 completes each step.

**Table 2-6**  
AC voltage calibration summary

Calibration step	Calibrator voltage, frequency
10mV AC at 1kHz	10.00000mV, 1kHz
100mV AC at 1kHz	100.0000mV, 1kHz
100mV AC at 50kHz	100.0000mV, 50kHz
1V AC at 1kHz	1.000000V, 1kHz
1V AC at 50kHz	1.000000V, 50kHz
10V AC at 1kHz	10.00000V, 1kHz
10V AC at 50kHz	10.00000V, 50kHz
100V AC at 1kHz	100.0000V, 1kHz
100V AC at 50kHz	100.0000V, 50kHz
700V AC at 1kHz	700.000V, 1kHz

**NOTE** Do not exceed  $\pm 15V$  peak between sense LO and LO. You may have to remove the external sense leads before calibrating AC volts. Even though some calibrators can turn off their external sense, the AC voltage can still cause excess voltage to appear between sense LO and LO.

## AC current calibration

After the 700V AC at 1kHz point has been calibrated, the unit will prompt you for 100mA at 1kHz. Follow these steps for AC current calibration:

1. Connect the calibrator to the AMPS and INPUT LO terminals of the Model 2010 as shown in Figure 2-3.
2. Perform the calibration steps summarized in Table 2-7. For each step:
  - Set the calibrator to the indicated current and frequency, and make sure the unit is in operate.
  - Press ENTER to complete each calibration step.
  - Allow the unit to complete each step before continuing.

**Table 2-7**  
*AC current calibration summary*

Calibration step	Calibrator current, frequency
100mA at 1kHz	100.0000mA, 1kHz
1A at 1kHz	1.000000A, 1kHz
2A at 1kHz	2.000000A, 1kHz

## Setting calibration dates

At the end of the calibration procedure, the instrument will display the CALIBRATION COMPLETE message. Press ENTER to continue, and the Model 2010 will prompt you to enter the calibration date and the calibration due date. Set these dates as follows:

1. At the CAL DATE: mm/dd/yy prompt, use the left and right arrow keys and the range keys to set the calibration date, and then press ENTER.
2. The unit will then prompt you to enter the next calibration due date with this prompt: CAL NDUE: mm/dd/yy. Use the left and right arrow keys and the range keys to set the calibration due date, and then press ENTER.
3. The unit will prompt you to save new calibration constants with this message: SAVE CAL? YES. To save the new constants, press ENTER. If you do not want to save the new constants, press the down range key to toggle to NO, and then press ENTER.

**NOTE** *Calibration constants calculated during the current calibration procedure will not be saved unless you choose the YES option. Previous calibration constants will be retained if you select NO.*

*If an incorrect date is entered, the "INVALID DATE" message will be displayed. The menu will remain until a valid date is entered.*

## Remote calibration

Use the following steps to perform comprehensive, DC-only, and AC-only calibration procedures by remote. See Appendix B for a detailed list and description of SCPI calibration commands.

When sending calibration commands, be sure that the Model 2010 completes each step before sending the next command. You can do so by observing the front panel CALIBRATING message or by detecting the completion of each step over the bus.

The procedures for calibrating the Model 2010 using SCPI commands include:

- Preparing the Model 2010 for calibration
- Front panel short and open calibration
- DC volts calibration
- Resistance calibration
- DC current calibration
- AC volts calibration
- AC current calibration
- Programming calibration dates
- Saving calibration constants
- Locking out calibration

**NOTE** *As with front panel calibration, you can choose to perform comprehensive, DC-only, or AC-only calibration. Be sure to include a space character between each command and parameter.*

## Preparing the Model 2010 for calibration

1. Connect the Model 2010 to the IEEE-488 bus of the computer using a shielded IEEE-488 cable, such as the Keithley Model 7007, or connect the unit to a computer through the RS-232 port using a straight-through 9-pin to 9-pin cable (use a 9-25-pin adapter if necessary).
2. Turn on the Model 2010, and allow it to warm up for two hours before performing calibration.
3. Select the DCV function, and choose SLOW as the rate (integration time = 5PLC).
4. Make sure the primary address of the Model 2010 is the same as the address specified in the program that you will be using to send commands. Use the GPIB key.
5. Unlock the calibration function by sending this command:

```
:CAL:PROT:CODE 'KI002010'
```

(The above command shows the default code, KI002010. Substitute the correct code if changed.)

6. Send the following command to initiate calibration:  
:CAL:PROT:INIT

## Short and open calibration

1. Connect the Model 8610 low-thermal short to the instrument INPUT and SENSE terminals as shown in Figure 2-1. Make sure the INPUTS button is not pressed in so that the front inputs are active. Wait at least three minutes before proceeding to allow for thermal equilibrium.

**NOTE** *Be sure to connect the low-thermal short properly to the HI, LO, and SENSE terminals. Keep drafts away from low-thermal connections to avoid thermal drift, which could affect calibration accuracy.*

2. Send the following command:  
:CAL:PROT:DC:STEP1
3. After the Model 2010 completes this step, remove the low-thermal short and send this command:  
:CAL:PROT:DC:STEP2

## DC volts calibration

After front panel short and open steps, perform the following:

1. Connect the calibrator to the Model 2010 as shown in Figure 2-2. Allow three minutes for thermal equilibrium.

**NOTE** Although 4-wire connections are shown, the sense leads are connected and disconnected at various points in this procedure by turning calibrator external sense on or off as appropriate. If your calibrator does not have provisions for turning external sense on and off, disconnect the sense leads when external sensing is to be turned off, and connect the sense leads when external sensing is to be turned on. Disconnect sense leads when calibrating and verifying AC volts.

**NOTE** Disconnect sense leads when calibrating and verifying AC volts.

2. Perform the calibration steps summarized in Table 2-8. For each step:
  - Set the calibrator to the indicated voltage, and make sure the unit is in operate. (Use the recommended voltage if possible.)
  - Send the indicated programming command. (Change the voltage parameter if you are using a different calibration voltage.)
  - Wait until the Model 2010 completes each step before continuing.

**Table 2-8**  
DC voltage calibration programming steps

Calibration step	Calibrator voltage	Calibration command*	Parameter range
+10V	+10.00000V	:CAL:PROT:DC:STEP3 10	9 to 11
-10V	-10.00000V	:CAL:PROT:DC:STEP4 -10	-9 to -11
100V	100.0000V	:CAL:PROT:DC:STEP5 100	90 to 110

\* Change parameter accordingly if using a different calibrator voltage.

## Resistance calibration

Follow these steps for resistance calibration:

1. Set the calibrator to the resistance mode, and turn on external sensing.

**NOTE** Use external sense (4-wire  $\Omega$ ) when calibrating all resistance ranges. Be sure that the calibrator external sense mode is turned on,

2. Perform the calibration steps summarized in Table 2-9. For each step:
  - Set the calibrator to the indicated resistance, and make sure the unit is in operate. (Use the recommended resistance or the closest available value.)
  - Send the indicated programming command. (Change the command parameter if you are using a different calibration resistance than that shown.)
  - Wait until the Model 2010 completes each step before continuing.

**Table 2-9**  
Resistance calibration programming steps

Calibration step	Calibrator resistance	Calibration command*	Parameter range
10 $\Omega$	10 $\Omega$	:CAL:PROT:DC:STEP6 10	9 to 11
1k $\Omega$	1k $\Omega$	:CAL:PROT:DC:STEP7 1E3	900 to 1.1E3
10k $\Omega$	10k $\Omega$	:CAL:PROT:DC:STEP8 10E3	9E3 to 11E3
100k $\Omega$	100k $\Omega$	:CAL:PROT:DC:STEP9 100E3	90E3 to 110E3
1M $\Omega$	1M $\Omega$	:CAL:PROT:DC:STEP10 1E6	900E3 to 1.1E6

\* Use exact calibrator resistance value for parameter.



## DC current calibration

After the 1M $\Omega$  resistance point has been calibrated, follow these steps for DC current calibration:

1. Connect the calibrator to the AMPS and INPUT LO terminals of the Model 2010 as shown in Figure 2-3.
2. Perform the calibration steps listed in Table 2-10. For each step:
  - Set the calibrator to the indicated current, and make sure the unit is in operate. (Use the recommended current if possible.)
  - Send the indicated programming command. (Change the current parameter if you are using a different calibration current.)
  - Wait until the Model 2010 completes each step before continuing.

**NOTE** *If you are performing DC-only calibration, proceed to Programming calibration dates.*

**Table 2-10**  
DC current calibration programming steps

Calibration step	Calibrator current	Calibration command*	Parameter range
10mA	10.00000mA	:CAL:PROT:DC:STEP11 10E-3	9E-3 to 11E-3
100mA	100.00000mA	:CAL:PROT:DC:STEP12 100E-3	90E-3 to 110E-3
1A	1.000000A	:CAL:PROT:DC:STEP13 1	0.9 to 1.1

\* Change parameter if using different current.

## AC voltage calibration

Follow these steps for AC voltage calibration:

1. Connect the calibrator to the Model 2010 INPUT HI and LO terminals as shown in Figure 2-4.

**NOTE** *Disconnect any sense leads from the calibrator to the Model 2010 when calibrating or verifying AC volts. Even though some calibrators provide an external sense enable/disable function, excessive voltage ( $\pm 15V$  peak) may be applied and will corrupt the calibration or verify.*

2. Perform the calibration steps summarized in Table 2-11. For each step:
  - Set the calibrator to the indicated voltage and frequency, and make sure the unit is in operate. (You must use the stated voltage and frequency.)
  - Send the indicated programming command.
  - Wait until the Model 2010 completes each step before continuing.

**Table 2-11**  
AC voltage calibration programming steps

Calibration step	Calibrator voltage, frequency	Calibration command
10mV AC at 1kHz	10.00000mV, 1kHz	:CAL:PROT:AC:STEP1
100mV AC at 1kHz	100.0000mV, 1kHz	:CAL:PROT:AC:STEP2
100mV AC at 50kHz	100.0000mV, 50kHz	:CAL:PROT:AC:STEP3
1V AC at 1kHz	1.000000V, 1kHz	:CAL:PROT:AC:STEP4
1V AC at 50kHz	1.000000V, 50kHz	:CAL:PROT:AC:STEP5
10V AC at 1kHz	10.00000V, 1kHz	:CAL:PROT:AC:STEP6
10V AC at 50kHz	10.00000V, 50kHz	:CAL:PROT:AC:STEP7
100V AC at 1kHz	100.0000V, 1kHz	:CAL:PROT:AC:STEP8
100V AC at 50kHz	100.0000V, 50kHz	:CAL:PROT:AC:STEP9
700V AC at 1kHz	700.000V, 1kHz	:CAL:PROT:AC:STEP10

## AC current calibration

Follow these steps for AC current calibration:

1. Connect the calibrator to the AMPS and INPUT LO terminals of the Model 2010 as shown in Figure 2-3.
2. Perform the calibration steps summarized in Table 2-12. For each step:
  - Set the calibrator to the indicated current and frequency, and make sure the unit is in operate. (You must use the stated current and frequency.)
  - Send the indicated programming command.
  - Wait until the Model 2010 completes each step before continuing.

**Table 2-12**  
AC current calibration programming steps

Calibration step	Calibrator current, frequency	Calibration command
100mA at 1kHz	100.0000mA, 1kHz	:CAL:PROT:AC:STEP11
1A at 1kHz	1.000000A, 1kHz	:CAL:PROT:AC:STEP12
2A at 1kHz	2.000000A, 1kHz	:CAL:PROT:AC:STEP13

## Programming calibration dates

Program the present calibration date and calibration due date by sending the following commands:

```
:CAL:PROT:DATE <year>, <month>, <day>
:CAL:PROT:NDUE <year>, <month>, <day>
```

For example, the following commands assume calibration dates of 12/15/95 and 3/14/96 respectively:

```
:CAL:PROT:DATE 1995, 12, 15
:CAL:PROT:NDUE 1996, 3, 14
```

**NOTE** If an incorrect date is sent, an error will be generated.

## Saving calibration constants

After completing the calibration procedure, send the following command to save the new calibration constants:

```
:CAL:PROT:SAVE
```

*NOTE* Calibration constants will not be saved unless the :SAVE command is sent.

## Locking out calibration

After saving calibration, send the following command to lock out calibration:

```
:CAL:PROT:LOCK
```

## Manufacturing calibration

The manufacturing procedure is normally performed only at the factory, but the necessary steps are included here in case the unit is repaired, and the unit requires these calibration procedures.

*NOTE* If the unit has been repaired, the entire comprehensive calibration procedure should also be performed in addition to the manufacturing calibration procedure.

### Recommended test equipment

Table 2-13 summarizes the test equipment required for the manufacturing calibration steps. In addition, you will need the Fluke 5700A Calibrator (see Table 2-1) to complete the comprehensive calibration steps.

*Table 2-13*  
*Recommended equipment for manufacturing calibration*

Keithley 3930A or 3940 Frequency Synthesizer:

1V RMS, 3Hz,  $\pm 5$ ppm

1V RMS, 1kHz,  $\pm 5$ ppm

Keithley Model 2001 or 2002 Digital Multimeter:

1V, 3Hz AC,  $\pm 0.13\%$

Keithley Model 8610 Low-thermal short

### Unlocking manufacturing calibration

To unlock manufacturing calibration, press and hold in the OPEN key while turning on the power.

### Measuring synthesizer signal amplitude

The 3Hz synthesizer signal amplitude must be accurately measured using the digital multimeter listed in Table 2-13. Proceed as follows:

1. Connect the synthesizer output to the Model 2001/2002 Digital Multimeter INPUT jacks. (See Figure 2-5 for typical connections.)
2. Turn on the synthesizer and multimeter, and allow a two-hour warm-up period before measuring.
3. Set the synthesizer to output a 1V RMS sine wave at 3Hz; measure and record the signal amplitude.

## Front panel manufacturing calibration

1. Press in and hold the OPEN key while turning on the power.
2. Connect the low-thermal short to the rear panel input jacks, and select the rear inputs with the INPUTS switch. Allow three minutes for thermal equilibrium.
3. Press SHIFT then CAL, select RUN, and then enter the appropriate calibration code (default: 002010).
4. Select ALL at the CAL:RUN prompt.
5. Press ENTER.
6. Perform the entire front panel comprehensive calibration procedure discussed earlier in this section. (See Comprehensive calibration.)
7. Connect the synthesizer to the Model 2010 front panel INPUT jacks as shown in Figure 2-5. Select the front input jacks with the INPUTS switch.

**Figure 2-5**  
*Synthesizer connections for manufacturing calibration*

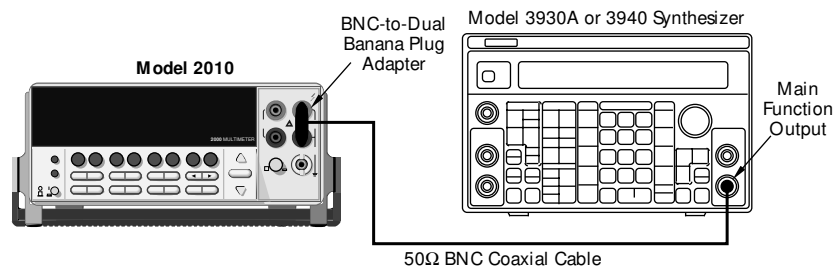

Note: Synthesizer output voltage must be accurately measured. (See text).

8. After the last AC current calibration step, the instrument will prompt you to enter 3Hz at 1V RMS and 1kHz with the following prompts:
  - Low-frequency cal: Set the synthesizer to output a 1V RMS, 3Hz sine wave. Use the left and right arrow keys and the range keys to adjust the display to agree with the synthesizer amplitude you measured previously, and then press ENTER.
  - Frequency cal: Set the synthesizer to output a 1V RMS, 1kHz sine wave. Enter 1.000000kHz at the prompt, and then press ENTER.
9. Set the calibration dates, and then save calibration to complete the process.

## Remote manufacturing calibration

1. Connect the low-thermal short to the rear panel input jacks, and select the rear inputs with the INPUTS switch. Allow three minutes for thermal equilibrium.
2. Press in and hold the OPEN key while turning on the power.
3. Enable calibration by sending the :CODE command. For example, the default command is:  
`:CAL:PROT:CODE 'KI002010'`
4. Initiate calibration by sending the following command:  
`:CAL:PROT:INIT`
5. Calibrate step 0 with the following command:  
`:CAL:PROT:AC:STEP0`
6. Perform the entire SCPI command comprehensive calibration procedure discussed earlier in this section. (See Comprehensive calibration.)
7. Connect the synthesizer to the Model 2010 INPUT jacks as shown in Figure 2-5. Select the front input jacks with the INPUTS switch.
8. Set the synthesizer to output a 1V RMS, 3Hz sine wave, and then send the following command:  
`:CAL:PROT:AC:STEP14 <Cal_voltage>`  
<Cal\_voltage> is the actual 3Hz synthesizer signal amplitude you measured previously.
9. Set the synthesizer to output a 1V RMS, 1kHz sine wave, and then send the following command:  
`:CAL:PROT:AC:STEP15 1E3`
10. Send the following commands to set calibration dates, save calibration, and lock out calibration:  
`:CAL:PROT:DATE <year>, <month>, <day>`  
`:CAL:PROT:NDUE <year>, <month>, <day>`  
`:CAL:PROT:SAVE`  
`:CAL:PROT:LOCK`

---

# 3 Routine Maintenance



## Introduction

This section describes routine type maintenance that can be performed by the operator and includes procedures for replacing both the line fuse and the amps fuse.

## Setting the line voltage and replacing the line fuse

**WARNING** *Disconnect the line cord at the rear panel, and remove all test leads connected to the instrument (front and rear) before replacing the line fuse.*

The power line fuse is located in the power module next to the AC power receptacle (see Figure 3-1). If the line voltage must be changed or if the line fuse requires replacement, perform the following steps:

1. Place the tip of a flat-blade screwdriver into the power module by the fuse holder assembly (see Figure 3-1). Gently push in and turn to the left. Release pressure on the assembly, and its internal spring will push it out of the power module.
2. Remove the fuse, and replace it with the type listed in Table 3-1.

**CAUTION** *For continued protection against fire or instrument damage, replace the fuse only with the type and rating listed. If the instrument repeatedly blows fuses, locate and correct the cause of the trouble before replacing the fuse.*

3. If configuring the instrument for a different line voltage, remove the line voltage selector from the assembly, and rotate it to the proper position. When the selector is installed into the fuse holder assembly, the correct line voltage appears inverted in the window.
4. Install the fuse holder assembly into the power module by pushing it in until it locks in place.

**Figure 3-1**  
Power module

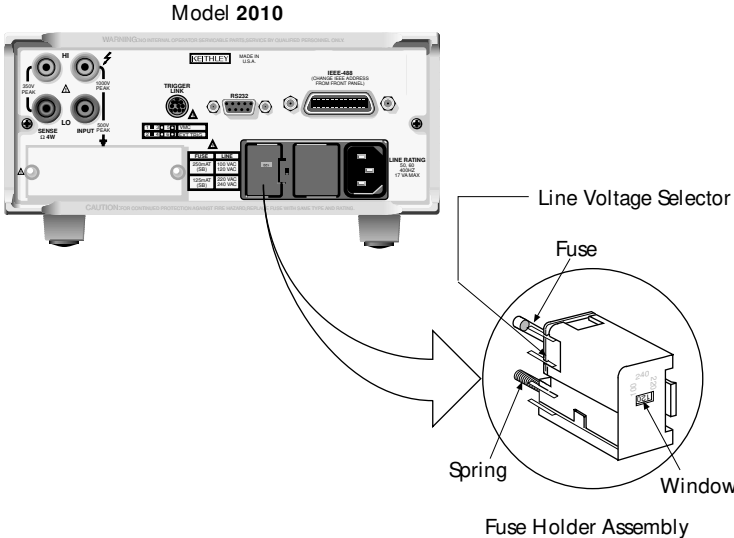

**Table 3-1**  
Power line fuse

Line voltage	Rating	Keithley part no.
100/120V	0.25A, slow-blow	FU-96-4
220/240V	0.125A, slow-blow	FU-91

Note: 5 × 20mm fuses required

## Replacing the AMPS fuse

The AMPS fuse protects the current input from an over-current condition. Follow the steps below to replace the AMPS fuse.

**WARNING** *Make sure the instrument is disconnected from the power line and other equipment before replacing the AMPS fuse.*

1. Turn off the power, and disconnect the power line and test leads.
2. From the front panel, gently push in the AMPS jack with your thumb, and rotate the fuse carrier one-quarter turn counter-clockwise. Release pressure on the jack, and its internal spring will push the fuse carrier out of the socket.
3. Remove the fuse, and replace it with the same type: 3A, 250V, fast blow, Keithley part number FU-99-1.

**CAUTION** *Do not use a fuse with a higher current rating than specified, or instrument damage may occur. If the instrument repeatedly blows fuses, locate and correct the cause of the trouble before replacing the fuse.*

4. Install the new fuse by reversing the above procedure.

---

# 4 Troubleshooting

## Introduction

This section of the manual will assist you in troubleshooting and repairing the Model 2010. Included are self-tests, test procedures, troubleshooting tables, and circuit descriptions. It is left to the discretion of the repair technician to select the appropriate tests and documentation needed to troubleshoot the instrument.

**WARNING** *The information in this section is intended for qualified service personnel only. Do not perform these procedures unless you are qualified to do so. Some of these procedures may expose you to hazardous voltages that could cause personal injury or death. Use caution when working with hazardous voltages.*

## Repair considerations

Before making any repairs to the Model 2010, be sure to read the following considerations.

**CAUTION** *The PC boards are built using surface mount techniques and require specialized equipment and skills for repair. If you are not equipped and/or qualified, it is strongly recommended that you send the unit back to the factory for repairs or limit repairs to the PC board replacement level. Without proper equipment and training, you could damage a PC board beyond repair.*

- Repairs will require various degrees of disassembly. However, it is recommended that the Front Panel Tests be performed prior to any disassembly. The disassembly instructions for the Model 2010 are contained in Section 5 of this manual.
- Do not make repairs to surface mount PC boards unless equipped and qualified to do so (see previous CAUTION).
- When working inside the unit and replacing parts, be sure to adhere to the handling precautions and cleaning procedures explained in Section 5.
- Many CMOS devices are installed in the Model 2010. These static-sensitive devices require special handling as explained in Section 5.
- Whenever a circuit board is removed or a component is replaced, the Model 2010 must be recalibrated. See Section 2 for details on calibrating the unit.

## Power-on self-test

During the power-on sequence, the Model 2010 will perform a checksum test on its EPROM (U156 and U157) and test its RAM (U151 and U152). If one of these tests fails, the instrument will lock up.

## Front panel tests

There are two front panel tests: one to test the functionality of the front panel keys and one to test the display. In the event of a test failure, refer to Display board checks for details on troubleshooting the display board.

### KEY test

The KEY test allows you to check the functionality of each front panel key. Perform the following steps to run the KEY test:

1. Press SHIFT and then TEST to access the self-test options.
2. Use the up or down RANGE key to display TEST: KEY.
3. Press ENTER to start the test. When a key is pressed, the label name for that key is displayed to indicate that it is functioning properly. When the key is released, the “NO KEY PRESS” message is displayed.
4. Pressing EXIT tests the EXIT key. However, the second consecutive press of EXIT aborts the test and returns the instrument to normal operation.

### DISP test

The display test allows you to verify that each segment and annunciator in the vacuum fluorescent display is working properly. Perform the following steps to run the display test:

1. Press SHIFT and then TEST to access the self-test options.
2. Use the up or down RANGE key to display TEST: DISP.
3. Press ENTER to start the test. There are four parts to the display test. Each time ENTER is pressed, the next part of the test sequence is selected. The four parts of the test sequence are:
  - All annunciators are displayed.
  - The segments of each digit are sequentially displayed.
  - The 12 digits (and annunciators) are sequentially displayed.
  - The annunciators located at either end of the display are sequentially displayed.
4. When finished, abort the display test by pressing EXIT. The instrument returns to normal operation.

## Principles of operation

The following information is provided to support the troubleshooting tests and procedures covered in this section of the manual. Refer to the following block diagrams:

Figure 4-1 — Power supply block diagram

Figure 4-2 — Digital circuitry block diagram

Figure 4-3 — Analog circuitry block diagram

### Power supply

The following information provides some basic circuit theory that can be used as an aid to troubleshoot the power supply. A block diagram of the power supply is shown in Figure 4-1.

AC power is applied to the AC power module receptacle (J1009). Power is routed through the line fuse and line voltage selection switch of the power module to the power transformer. The power transformer has a total of four secondary windings for the various supplies.

AC voltage for the display filaments is taken from a power transformer secondary at F1 and F2, and then routed to the display board.

Each DC supply uses a rectifier and a capacitive filter, and many supplies use an IC regulator. Table 4-1 summarizes rectifier, filter, and regulator circuits for the various DC supplies.

**Table 4-1**  
*Power supply components*

Supply	Rectifier	Filter	Regulator
+5VD	CR104	C156, C175	U144
+37V	CR116, CR117	C104	U101
+15V	CR102	C148	U180
-15V	CR102	C131	U179
+5V, +5VRL	CR103	C146	U124
+25V	CR136, CR140, CR141	C281	—
-25V	CR137, CR138, CR139	C284	—
+18V	CR102	—	—
-18V	CR102	—	—
+20V	—	C279, C281	U187

**Figure 4-1**  
Power supply  
block diagram

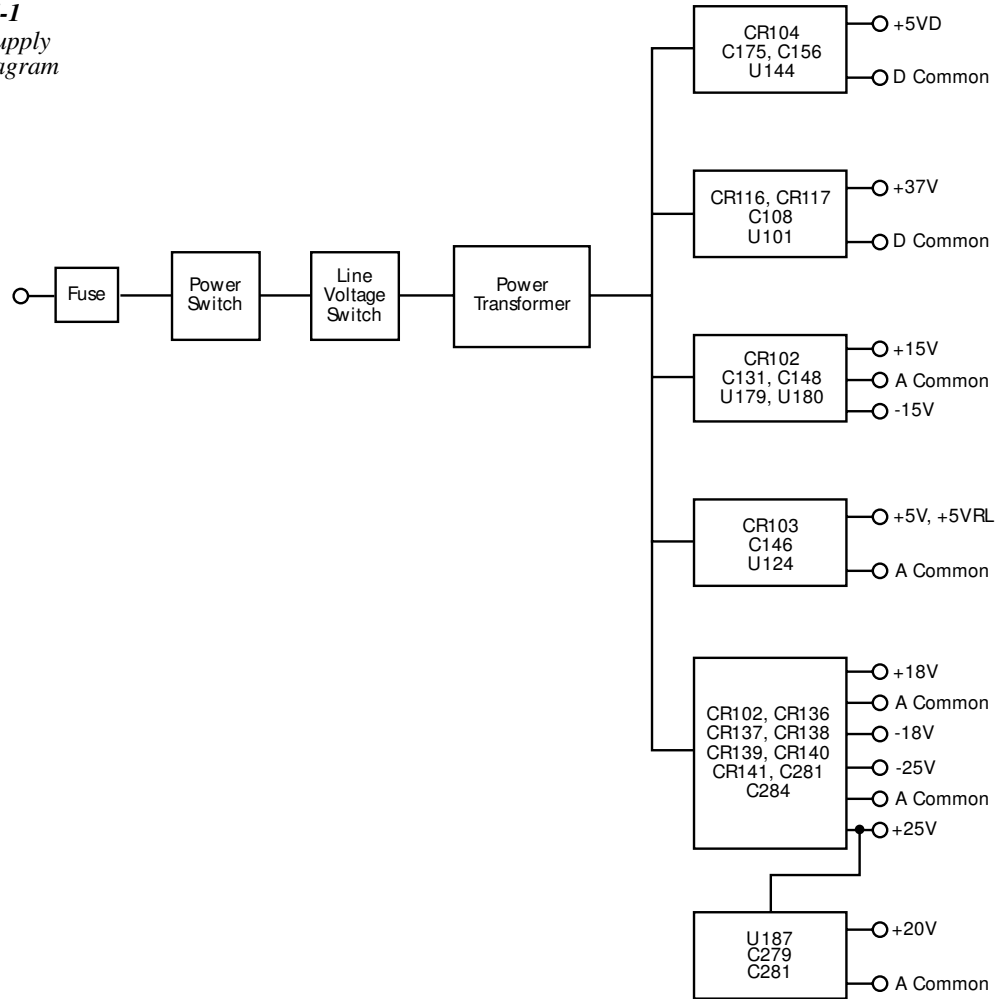



## Display board

Display board components are shown in the digital circuitry block diagram in Figure 4-2.

### Microcontroller

U401 is the display board microcontroller that controls the display and interprets key data. The microcontroller uses three internal peripheral I/O ports for the various control and read functions. Display data is serially transmitted to the microcontroller from the digital section via the TXB line to the microcontroller RDI terminal. In a similar manner, key data is serially sent back to the digital section through the RXB line via TDO. The 4MHz clock for the microcontroller is generated by crystal Y401.

### Display

DS401 is the display module, which can display up to 12 alphanumeric characters and includes the various annunciators.

The display uses a common multiplexing scheme with each character refreshed in sequence. U402 and U403 are the drivers for the display characters and annunciators. Note that data for the drivers is serially transmitted from the microcontroller (MOSI and PC1).

Filament voltage for the display is derived from the power supply transformer (F1 and F2). The display drivers require +37VDC and +5VDC, which are supplied by U144 (+5VD) and U101 (+37V).

### Key matrix

The front panel keys (S401-S430) are organized into a row-column matrix to minimize the number of microcontroller peripheral lines required to read the keyboard. A key is read by strobing the columns and reading all rows for each strobed column. Key-down data is interpreted by the display microcontroller and sent back to the main microprocessor using proprietary encoding schemes.

## Digital circuitry

Refer to Figure 4-2 for the following discussion on digital circuitry.

### Microprocessor

U135 is a 68306 microprocessor that oversees all operating aspects of the instrument. The MPU has a 16-bit data bus and provides an 18-bit address bus. It also has parallel and serial ports for controlling various circuits. For example, the RXDA, TXDA, RXDB and TXDB lines are used for the RS-232 interface.

The MPU clock frequency of 14.7456MHz is controlled by crystal Y101.

**Figure 4-2**  
Digital circuitry  
block diagram

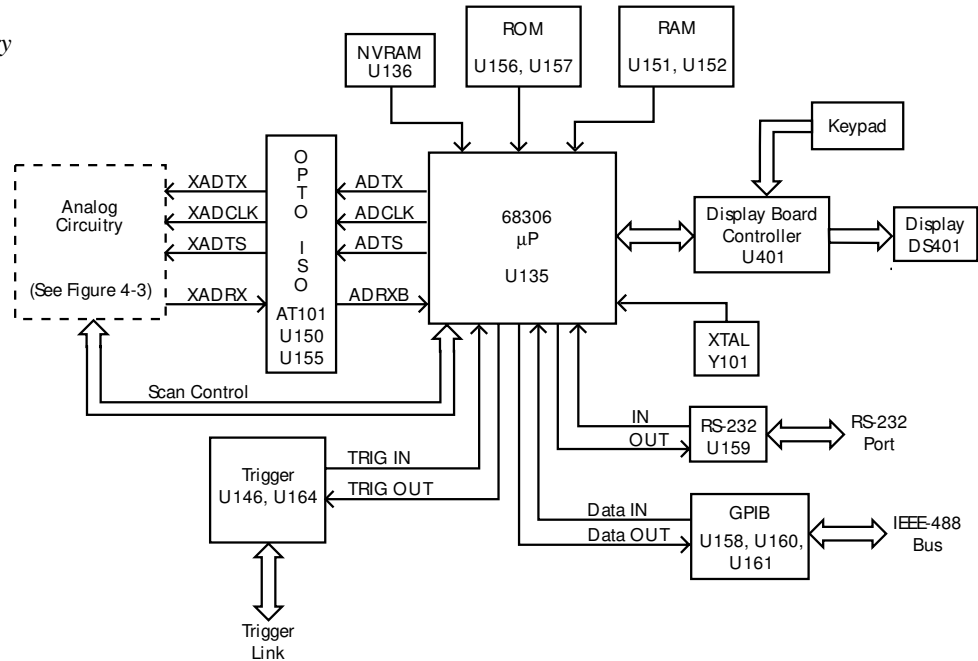

### Memory circuits

ROMs U156 and U157 store the firmware code for instrument operation. U157 stores the D0-D7 bits of each data word, and U156 stores the D8-D15 bits.

RAMs U151 and U152 provide temporary operating storage. U152 stores the D0-D7 bits of each data word, and U151 stores the D8-D15 bits.

Semi-permanent storage facilities include NVRAM U136. This IC stores such information as instrument setup and calibration constants. Data transmission from this device is performed serially.

### RS-232 interface

Serial data transmission and reception is performed by the TXDB and RXDB lines of the MPU. U159 provides the necessary voltage level conversion for the RS-232 interface port.

### IEEE-488 interface

U158, U160, and U161 make up the IEEE-488 interface. U158, a 9914A GPIA, takes care of routine bus overhead such as handshaking, while U160 and U161 provide the necessary buffering and drive capabilities.

### Trigger circuits

Buffering for Trigger Link input and output is performed by U146. Trigger input and output is controlled by the IRQ4 and PB3 lines of the MPU. U164 provides additional logic for the trigger input to minimize MPU control overhead.

At the factory, trigger output is connected to line 1 of the Trigger Link connector (resistor R267 installed). Trigger input is connected to line 2 of the Trigger Link connector (resistor R270 installed).

### Analog circuitry

Refer to Figure 4-3 for the following discussion on analog circuitry.

**Figure 4-3**  
Analog circuitry  
block diagram

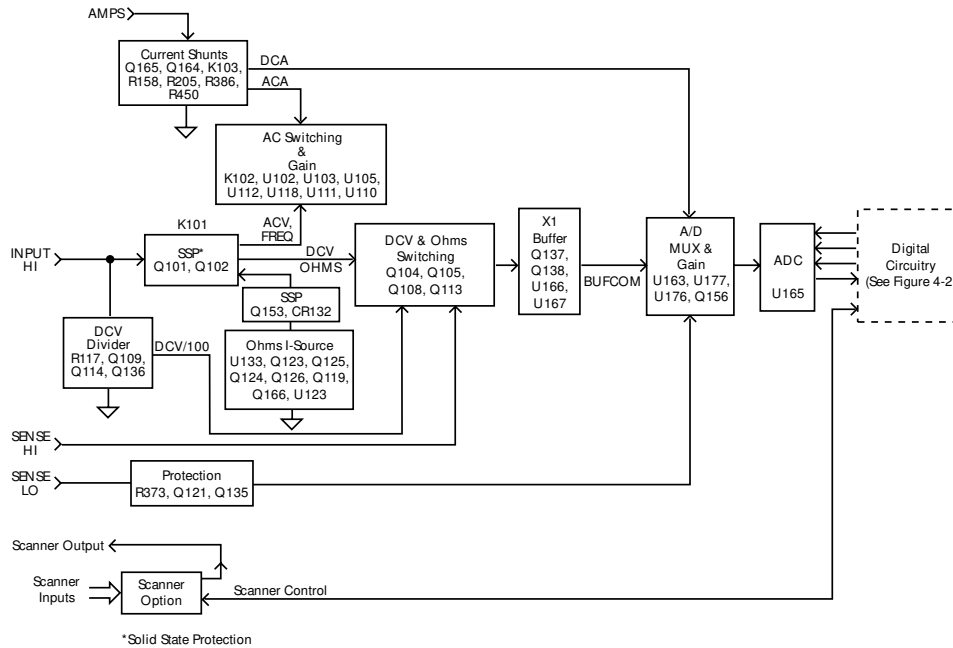

### INPUT HI

INPUT HI protection is provided by the SSP (solid state protection) circuit. The SSP is primarily made up of Q101 and Q102. An overload condition opens Q101 and Q102, which disconnects the analog input signal from the rest of the analog circuit.

Note that for the 100VDC and 1000VDC ranges, Q101 and Q102 of the SSP are open. The DC voltage signal is routed through the DCV Divider (Q114 and Q136) to the DCV switching circuit.

## AMPS input

The ACA or DCA input signal is applied to the Current Shunt circuit, which is made up of K103, Q165, Q164, R205, R450, R386, and R158. U178 controls if either Q164 or Q165 is turned on. For the 3A and 1A DCA ranges and all ACA ranges,  $0.1\Omega$  (R158) is shunted across the input (K103 off). For the 100mA DCA range, K103 is energized (on). Q164 (both) are turned on with the LOAMP control line set high.  $1.01\Omega$  (R386 + R158) is shunted across the input. For the 10mA DCA range, K103 is energized (on). Q165 (both) are turned on with the LOAMP control line set low.  $10.1\Omega$  (R205//R450 + R386 + R158) is shunted across the input.

The ACA signal is then sent to the AC Switching & Gain circuit, while the DCA signal is routed directly to the A/D MUX & Gain circuit.

## Signal switching

Signal switching for DCV and OHMS is done by the DCV & Ohms Switching circuit. FETs Q113, Q105, Q104, and Q108 connect the DCV or ohms signal to the X1 buffer (Q137, U167, and U166). (See Analog signal switching states at the end of this section for a summary of switching states of these FETs for the various DCV and OHMS ranges.)

Note that the reference current for OHMS is generated by the Ohms I-Source circuit. For 4-wire ohms measurements, SENSE LO is connected to the circuit by controlling U163.

Signal switching and gain for ACV, FREQ, and ACA is done by the AC Switching & Gain circuit, which is primarily made up of K102, U102, U103, U105, U112, U118, U111, and U110. (See Analog signal switching states.) Note that U111 is used for frequency adjustment. The states of these analog switches vary from range to range.

## Multiplexer and A/D converter

All input signals, except FREQ, are routed to the A/D MUX & Gain circuit. The multiplexer (U163) switches the various signals for measurement. In addition to the input signal, the multiplexer also switches among reference and zero signals at various phases of the measurement cycle.

When the input signal is selected by the MUX, it is amplified by a composite operational amplifier made up of Q156 and U177. Tables in Analog signal switching states at the end of this section provide the switch states of U176, which determine the gain for Q156 and U177.

The multiplexed signals of the measurement cycle are routed to the A/D Converter (U165), where it converts the analog signals to digital form. The digital signals are then routed through an opto-isolator to the MPU to calculate a reading.

## Troubleshooting

Troubleshooting information for the various circuits is summarized below. See Analog signal switching states for additional information regarding the analog circuitry.

### Display board checks

If the front panel DISP test indicates that there is a problem on the display board, use Table 4-2. See Principles of operation for display circuit theory.

**Table 4-2**  
*Display board checks*

Step	Item/component	Required condition	Remarks
1	Front panel DISP test.	Verify that all segments operate.	Use front panel display test.
2	P1005, pin 5	+5V $\pm$ 5%	Digital +5V supply.
3	P1005, pin 9	+37V $\pm$ 5%	Display +37V supply.
4	U401, pin 1	Goes low briefly on power up, then goes high.	Microcontroller RESET.
5	U401, pin 43	4MHz square wave.	Controller 4MHz clock.
6	U401, pin 32	Pulse train every 1ms.	Control from main processor.
7	U401, pin 33	Brief pulse train when front panel key is pressed.	Key down data sent to main processor.

## Power supply checks

Power supply problems can be checked using Table 4-3. See Principles of operation for circuit theory on the power supply.

**Table 4-3**  
*Power supply checks*

Step	Item/component	Required condition	Remarks
1	Line fuse	Check continuity.	Remove to check.
2	Line voltage	120V/240V as required.	Check power module position.
3	Line power	Plugged into live receptacle, power on.	Check for correct power-up sequence.
4	U144, pin 2	+5V $\pm$ 5%	+5VD, referenced to Common D.
5	U101, pin 7	+37V $\pm$ 5%	+37V, referenced to Common D.
6	U180, pin 3	+15V $\pm$ 5%	+15V, referenced to Common A.
7	U179, pin 3	-15.7V $\pm$ 5%	-15V, referenced to Common A.
8	U124, pin 3	+5V $\pm$ 5%	+5VRL, referenced to Common A.
9	CR141 cathode	+25V $\pm$ 20%	+25V, referenced to Common A.
10	CR139 anode	-25V $\pm$ 20%	-25V, referenced to Common A.
11	U180, pin 1	+18V $\pm$ 20%	+18V, referenced to Common A.
12	U179, pin 2	-18V $\pm$ 20%	-18V, referenced to Common A.
13	Q183, emitter	+21V $\pm$ 5%	+20V, referenced to Common A.

## Digital circuitry checks

Digital circuit problems can be checked using Table 4-4. See Principles of operation for a digital circuit description.

**Table 4-4**  
*Digital circuitry checks*

Step	Item/component	Required condition	Remarks
1	Power-on test	RAM OK, ROM OK.	Verify that RAM and ROM are functional.
2	U157 pin 16	Digital common.	All signals referenced to digital common.
3	U157 pin 32	+5V	Digital logic supply.
4	U135 pin 48	Low on power-up, then goes high.	MPU RESET line.
5	U135, lines A1-A23	Check for stuck bits.	MPU address bus.
6	U135, lines D1-D15	Check for stuck bits.	MPU data bus.
7	U135 pin 44	14.7456MHz	MPU clock.
8	U159 pin 13	Pulse train during RS-232 I/O.	RS-232 RX line.
9	U159 pin 14	Pulse train during RS-232 I/O.	RS-232 TX line.
10	U158 pins 34-42	Pulse train during IEEE-488 I/O.	IEEE-488 data bus.
11	U158 pins 26-31	Pulses during IEEE-488 I/O.	IEEE-488 command lines.
12	U158 pin 24	Low with remote enabled.	IEEE-488 REN line.
13	U158 pin 25	Low during interface clear.	IEEE-488 IFC line.
14	U135 pin 84	Pulse train.	ADRXB
15	U135 pin 91	Pulse train.	ADTX
16	U135 pin 90	Pulse train.	ADCLK
17	U135 pin 89	Pulse train.	ADTS

## Analog signal switching states

Tables 4-5 through 4-11 provide switching states of the various relays, FETs, and analog switches for the basic measurement functions and ranges. These tables can be used to assist in tracing an analog signal from the input to the A/D multiplexer.

**Table 4-5**  
DCV signal switching

Range	Q101	Q102	Q114	Q136	Q109	K101*	Q113	Q105	Q104	Q108		
100mV	ON	ON	OFF	OFF	OFF	SET	OFF	ON	ON	OFF		
1V	ON	ON	OFF	OFF	OFF	SET	OFF	ON	ON	OFF		
10V	ON	ON	OFF	OFF	OFF	SET	OFF	OFF	ON	OFF		
100V	OFF	OFF	ON	ON	OFF	SET	OFF	OFF	OFF	ON		
1000V	OFF	OFF	ON	ON	OFF	SET	OFF	OFF	OFF	ON		
<b>Sense volts</b>											<b>Q154</b>	<b>Q153</b>
100mV	OFF	OFF	OFF	OFF	OFF	SET	ON	OFF	OFF	OFF	ON	ON
1V	OFF	OFF	OFF	OFF	OFF	SET	ON	OFF	OFF	OFF	ON	ON
10V	OFF	OFF	OFF	OFF	OFF	SET	ON	OFF	OFF	OFF	ON	ON

\*K101 SET states: Pin 8 switched to Pin 7  
Pin 3 switched to Pin 4

**Table 4-6**  
ACV and FREQ signal switching

Range	Q101	Q102	K101*	K102*	U103 pin 8	U103 pin 9	U105 pin 9	U105 pin 8	U103 pin 16	U103 pin 1	U105 pin 1	U111 pin 16
100mV	ON	ON	RESET	RESET	ON	ON	OFF	OFF	OFF	ON	ON	OFF
1V	ON	ON	RESET	RESET	ON	ON	OFF	OFF	ON	OFF	OFF	OFF
10V	ON	ON	RESET	SET	OFF	OFF	ON	OFF	OFF	ON	ON	OFF
100V	ON	ON	RESET	SET	OFF	OFF	ON	OFF	ON	OFF	OFF	OFF
750V	ON	ON	RESET	SET	OFF	OFF	ON	ON	OFF	OFF	OFF	OFF

\*K101 and K102 RESET states: Pin 8 switched to Pin 9  
Pin 3 switched to Pin 2  
K101 and K102 SET states: Pin 8 switched to Pin 7  
Pin 3 switched to Pin 4



**Table 4-7**  
*Ω2 signal switching*

Range	K104	Q101	Q102	Q114	Q136	Q109	K101*	K102*	Q113	Q105	Q104	Q108	Q153	Q167
10Ω	RESET	ON	ON	OFF	OFF	OFF	SET	RESET	OFF	ON	OFF	OFF	ON	OFF
100Ω	RESET	ON	ON	OFF	OFF	OFF	SET	RESET	OFF	ON	OFF	OFF	ON	OFF
1kΩ	RESET	ON	ON	OFF	OFF	OFF	SET	RESET	OFF	ON	OFF	OFF	ON	OFF
10kΩ	RESET	ON	ON	OFF	OFF	OFF	SET	RESET	OFF	ON	OFF	OFF	ON	OFF
100kΩ	RESET	ON	ON	OFF	OFF	OFF	SET	RESET	OFF	ON	OFF	OFF	ON	OFF
1MΩ	RESET	ON	ON	OFF	OFF	OFF	SET	RESET	OFF	ON	OFF	OFF	ON	OFF
10MΩ	RESET	ON	ON	OFF	OFF	ON	SET	SET	OFF	ON	OFF	OFF	OFF	OFF
100MΩ	RESET	ON	ON	OFF	OFF	ON	SET	SET	OFF	ON	OFF	OFF	OFF	OFF

\*K101 set states: Pin 8 switched to Pin 7  
Pin 3 switched to Pin 4  
K102 reset states: Pin 8 switched to Pin 9  
Pin 3 switched to Pin 2

**Table 4-8**  
*Ω4 signal switching*

Range	K104	Q101	Q102	Q114	Q136	Q109	K101*	K102*	Q113	Q105	Q104	Q108	Q153	Q167
10Ω	RESET	OFF	OFF	OFF	OFF	OFF	SET	RESET	ON	OFF	OFF	OFF	ON	OFF
100Ω	RESET	OFF	OFF	OFF	OFF	OFF	SET	RESET	ON	OFF	OFF	OFF	ON	OFF
1kΩ	RESET	OFF	OFF	OFF	OFF	OFF	SET	RESET	ON	OFF	OFF	OFF	ON	OFF
10kΩ	RESET	OFF	OFF	OFF	OFF	OFF	SET	RESET	ON	OFF	OFF	OFF	ON	OFF
100kΩ	RESET	OFF	OFF	OFF	OFF	OFF	SET	RESET	ON	OFF	OFF	OFF	ON	OFF
1MΩ	RESET	OFF	OFF	OFF	OFF	OFF	SET	RESET	ON	OFF	OFF	OFF	ON	OFF
10MΩ	RESET	ON	ON	OFF	OFF	ON	SET	SET	OFF	ON	OFF	OFF	OFF	OFF
100MΩ	RESET	ON	ON	OFF	OFF	ON	SET	SET	OFF	ON	OFF	OFF	OFF	OFF
<b>Dry circuit</b>														
10Ω	SET	OFF	OFF	ON	ON	OFF	RESET	RESET	ON	OFF	OFF	OFF	ON	ON
100Ω	SET	OFF	OFF	ON	ON	OFF	RESET	RESET	ON	OFF	OFF	OFF	ON	ON

\*K101 set states: Pin 8 switched to Pin 7  
Pin 3 switched to Pin 4  
K102 reset states: Pin 8 switched to Pin 9  
Pin 3 switched to Pin 2

**Table 4-9**  
*Ω2/Ω4 reference switching*

Range	U133 pin 8	U133 pin 1	Q123	Q125	Q124	Q126
10Ω	OFF	ON	ON	ON	OFF	OFF
100Ω	ON	OFF	ON	ON	OFF	OFF
1kΩ	ON	OFF	ON	ON	OFF	OFF
10kΩ	OFF	ON	OFF	OFF	ON	ON
100kΩ	ON	OFF	OFF	OFF	ON	ON
1MΩ	ON	OFF	OFF	OFF	ON	ON
10MΩ	OFF	ON	OFF	OFF	ON	ON
100MΩ	OFF	ON	OFF	OFF	ON	ON
<b>Dry circuit</b>						
10Ω	ON	OFF	ON	ON	OFF	OFF
100Ω	OFF	ON	OFF	OFF	ON	ON

**Table 4-10**  
*DCA signal switching*

Range	K103	Q165	Q164
10mA	ON	ON	OFF
100mA	ON	OFF	ON
1A	OFF	OFF	ON
3A	OFF	OFF	ON

**Table 4-11**  
*ACA signal switching*

Range	K103	U105 pin 16	U105 pin 1	U111 pin 16	U105 pin 8	U103 pin 16	U103 pin 1
1A	OFF	ON	ON	OFF	OFF	OFF	OFF
3A	OFF	ON	ON	ON	OFF	OFF	OFF

Tables 4-12 through 4-16 can be used to trace the analog signal through the A/D multiplexer (U163) to the final amplifier stage. These tables show the MUX lines (S3, S4, S6, S7) that are selected for measurement during the SIGNAL phase of the multiplexing cycle. Also included are switching states of analog switches (U176) that set up the gain for the final amplifier stage (U177).

**Table 4-12**  
DCV signal multiplexing and gain

Range	Signal (U163)	U176 pin 1	U176 pin 8	U176 pin 9	Gain (U177)	U129 pin 16
100mV	S4	OFF	OFF	OFF	X100	ON
1V	S4	OFF	OFF	ON	X10	OFF
10V	S4	OFF	ON	OFF	X1	OFF
100V	S4	OFF	OFF	ON	X10	OFF
1000V	S4	OFF	ON	OFF	X1	OFF

**Table 4-13**  
ACV and ACA signal multiplexing and gain

Range	U176 pin 1	U176 pin 8	U176 pin 9	Gain (U177)	U129 pin 1
All	ON	ON	OFF	X1	OFF

**Table 4-14**  
DCA signal multiplexing and gain

Range	Signal (U163)	U176 pin 1	U176 pin 8	U176 pin 9	Gain (U177)	U176 pin 16
10mA	S6	OFF	OFF	OFF	X100	ON
100mA	S6	OFF	OFF	OFF	X100	ON
1A	S6	OFF	OFF	OFF	X100	ON
3A	S6	OFF	OFF	ON	X10	OFF

**Table 4-15**  
*Ω2 signal multiplexing and gain*

Range	Signal (U163)	U176 pin 1	U176 pin 8	U176 pin 9	Gain (U177)	U176 pin 16
10Ω	S4	OFF	OFF	OFF	X100	ON
100Ω	S4	OFF	OFF	OFF	X100	ON
1kΩ	S4	OFF	OFF	ON	X10	OFF
10kΩ	S4	OFF	OFF	ON	X10	OFF
100kΩ	S4	OFF	OFF	ON	X10	OFF
1MΩ	S4	OFF	ON	OFF	X1	OFF
10MΩ	S4	OFF	ON	OFF	X1	OFF
100MΩ	S4	OFF	ON	OFF	X1	OFF

**Table 4-16**  
*Ω4 signal multiplexing and gain*

Range	Signal (U163)	U176 pin 1	U176 pin 8	U176 pin 9	Gain (U177)	U176 pin 16
10Ω	S4 then S7	OFF	OFF	OFF	X100	ON
100Ω	S4 then S7	OFF	OFF	OFF	X100	ON
1kΩ	S4 then S7	OFF	OFF	ON	X10	OFF
10kΩ	S4 then S7	OFF	OFF	ON	X10	OFF
100kΩ	S4 then S7	OFF	OFF	ON	X10	OFF
1MΩ	S4 then S7	OFF	ON	OFF	X1	OFF
10MΩ	S4 then S7	OFF	ON	OFF	X1	OFF
100MΩ	S4 then S7	OFF	ON	OFF	X1	OFF

Figure 4-3 provides a block diagram of the analog circuitry. Table 4-17 is provided to show where the various switching devices are located in the block diagram.

**Table 4-17**  
*Circuit section locations for switching devices*

Switching devices	Analog circuit section (see Figure 4-3)
Q101, Q102, Q153 Q114, Q136, Q109 K101, Q113, Q105, Q104, Q108, Q167 K102, U103, U105, U111 U133, Q123, Q125, Q124, Q126, Q120 K103, Q164, Q165 U163, U177, U176	SSP (Solid State Protection) DCV Divider DCV & Ohms Switching AC Switching & Gain Ohms I-Source Current Shunts A/D Mux & Gain

## No comm link error

A “No Comm Link” error indicates that the front panel processor has ceased communication with the main processor, which is located on the mother board. This error indicates that there may be a problem with the cable connection from the front panel display or one of the main processor ROMs may require re-seating in its socket. Check to be sure there is a proper cable connection from the front panel display. ROMs may be reseated as follows:

1. Turn off the power, and disconnect the line cord and all other test leads and cables from the instrument.
2. Remove the case cover as outlined in Section 5.
3. Find the two firmware ROMs, U156 and U157, located on the mother board. These are the only ICs installed in sockets. (Refer to the component layout drawing at the end of Section 6 for exact locations.)
4. Carefully push down on each ROM IC to make sure it is properly seated in its socket.

**CAUTION** *Be careful not to push down excessively, or you might crack the mother board.*

5. Connect the line cord, and turn on the power. If the problem persists, additional troubleshooting will be required.

---

# 5 Disassembly

## Introduction

This section explains how to handle, clean, and disassemble the Model 2010 Multimeter. Disassembly drawings are located at the end of this section.

## Handling and cleaning

To avoid contaminating PC board traces with body oil or other foreign matter, avoid touching the PC board traces while you are repairing the instrument. Motherboard areas covered by the shields have high-impedance devices or sensitive circuitry where contamination could cause degraded performance.

### Handling PC boards

Observe the following precautions when handling PC boards:

- Wear cotton gloves.
- Only handle PC boards by the edges and shields.
- Do not touch any board traces or components not associated with repair.
- Do not touch areas adjacent to electrical contacts.
- Use dry nitrogen gas to clean dust off PC boards.

### Solder repairs

Observe the following precautions when soldering a circuit board:

- Use an OA-based (organic activated) flux, and take care not to spread the flux to other areas of the circuit board.
- Remove the flux from the work area when you have finished the repair by using pure water with clean, foam-tipped swabs or a clean, soft brush.
- Once you have removed the flux, swab only the repair area with methanol, then blow-dry the board with dry nitrogen gas.
- After cleaning, allow the board to dry in a 50°C, low-humidity environment for several hours.

## Static sensitive devices

CMOS devices operate at very high impedance levels. Therefore, any static that builds up on you or your clothing may be sufficient to destroy these devices if they are not handled properly. Use the following precautions to avoid damaging them.

**CAUTION** *Many CMOS devices are installed in the Model 2010. Handle all semiconductor devices as being static sensitive.*

- Transport and handle ICs only in containers specially designed to prevent static build-up. Typically, you will receive these parts in anti-static containers made of plastic or foam. Keep these devices in their original containers until ready for installation.
- Remove the devices from their protective containers only at a properly grounded work station. Also, ground yourself with a suitable wrist strap.
- Handle the devices only by the body; do not touch the pins.
- Ground any printed circuit board into which a semiconductor device is to be inserted to the bench or table.
- Use only anti-static type desoldering tools.
- Use only grounded-tip solder irons.
- Once the device is installed in the PC board, it is normally adequately protected, and you can handle the boards normally.



## **Assembly drawings**

Use the following assembly drawings to assist you as you disassemble and re-assemble the Model 2010. Also, refer to these drawings for information about the Keithley part numbers of most mechanical parts in the unit. The drawings are located at the end of this section.

- Front Panel Assembly — 2010-040
- Chassis/Transformer Power Module Assembly — 2010-050
- Front Panel/Chassis Assembly — 2010-051
- Chassis Assembly — 2010-052

## Case cover removal

Follow the steps below to remove the case cover to gain access to internal parts.

**WARNING** *Before removing the case cover, disconnect the line cord and any test leads from the instrument.*

1. Remove Handle — The handle serves as an adjustable tilt-bail. Adjust its position by gently pulling it away from the sides of the instrument case and swinging it up or down. To remove the handle, swing the handle below the bottom surface of the case and back until the orientation arrows on the handles line up with the orientation arrows on the mounting ears. With the arrows lined up, pull the ends of the handle away from the case.
2. Remove Mounting Ears — Remove the screw that secures each mounting ear. Pull down and out on each mounting ear.

**NOTE** *When re-installing the mounting ears, make sure to mount the right ear to the right side of the chassis, and the left ear to the left side of the chassis. Each ear is marked "RIGHT" or "LEFT" on its inside surface.*

3. Remove Rear Bezel — To remove the rear bezel, loosen the two captive screws that secure the rear bezel to the chassis. Pull the bezel away from the case.
4. Removing Grounding Screws — Remove the two grounding screws that secure the case to the chassis. They are located on the bottom of the case at the back.
5. Remove Cover — To remove the case, grasp the front bezel of the instrument, and carefully slide the chassis forward. Slide the chassis out of the metal case.

**NOTE** *To gain access to the components under the motherboard shields, remove the shields, which are secured to the motherboard by their appropriate screw.*

## Changing trigger link lines

The Model 2010 uses two lines of the Trigger Link rear panel connector as External Trigger (EXT TRIG) input and Voltmeter Complete (VMC) output. At the factory, line 1 is configured as VMC and line 2 as EXT TRIG.

**NOTE** Line 1, 3, or 5 of the Trigger Link can be configured as VMC, while line 2, 4, or 6 can be configured as EXT TRIG.

You can change trigger link line configurations by moving the position of resistors inside the unit. Perform the following steps to change trigger link lines:

**WARNING** Make sure the instrument is disconnected from the power line and other equipment before performing the following procedure.

1. Remove the cover from the instrument as explained in Case cover removal.
2. The resistors used to select the trigger link lines are located next to the Trigger Link connector as shown in Figure 5-1. The “resistors” are actually solder beads that bridge pc-board pads. If the factory default lines are selected, the solder beads will be located at R270 (line 2, EXT TRIG) and R267 (line 1, VMC).
3. To change a trigger link line:
  - Use a hot air pencil to remove the appropriate solder bead.
  - Using a solder with OA-based flux, apply a solder bead to the appropriate resistor location.
  - Replace the cover on the instrument.

**Figure 5-1**  
Trigger link connectors

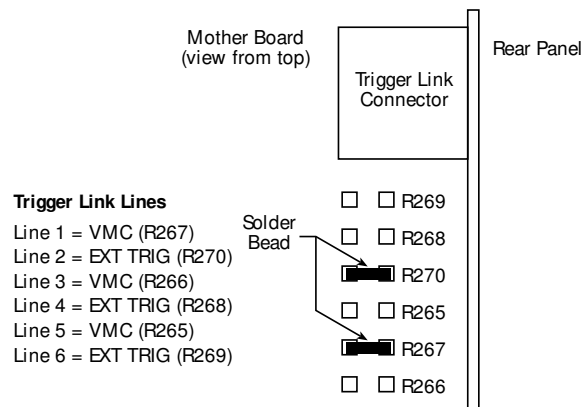

## Motherboard removal

Perform the following steps to remove the motherboard. This procedure assumes that the case cover is already removed.

1. Remove the IEEE-488 and RS-232 fasteners.

The IEEE-488 and the RS-232 connectors each have two nuts that secure the connectors to the rear panel. Remove these nuts.

2. Remove the front/rear switch rod.

At the switch, place the edge of a flat-blade screw driver in the notch on the pushrod. Gently twist the screw driver while pulling the rod from the shaft.

3. Disconnect the front and rear input terminals.

You must disconnect these input terminal connections for both the front and rear inputs:

- INPUT HI and LO
- SENSE HI and LO
- AMPS

Remove all the connections except the front AMPS connection by pulling the wires off the pin connectors. To remove the front panel AMPS input wire (white), first remove the AMPS fuse holder, and then use needle-nose pliers to grasp the AMP wire near fuse housing. Push the wire forward and down to snap the spring out of the fuse housing. Carefully pull the spring and contact tip out of housing.

During re-assembly, use the following table to identify input terminals:

Input terminals	Front wire color	Rear wire color
INPUT HI	Red	White/Red
INPUT LO	Black	White/Black
SENSE HI	Yellow	White/Yellow
SENSE LO	Gray	White/Gray
AMPS	White	—

4. Unplug cables:

- Unplug the display board ribbon cable from connector J1014.
- Unplug the transformer cables from connectors J1016 and J1015.
- Unplug the OPTION SLOT ribbon cable from connector J1017.

5. Remove the fastening screw that secures the main PC board to the chassis. This screw is located along the left side of the unit towards the rear. It also holds down U144.

During re-assembly, replace the board, and start the IEEE-488 and RS-232 connector nuts and the mounting screw. Tighten all the fasteners once they are all in place and the board is correctly aligned.

6. Remove the motherboard, which is held in place by edge guides on each side, by sliding it forward until the board edges clear the guides. Carefully pull the motherboard from the chassis.

## Front panel disassembly

Use the following procedures to remove the display board and/or the pushbutton switch pad:

**NOTE** *You must first remove the case cover, the front/rear input switch, and the front input terminal wires as described in earlier in this section.*

1. Unplug the display board ribbon cable from connector J1014.
2. Remove the front panel assembly.  
This assembly has four retaining clips that snap onto the chassis over four pem nut studs. Two retaining clips are located on each side of the front panel. Pull the retaining clips outward and at the same time pull the front panel assembly forward until it separates from the chassis.
3. Using a thin-bladed screw driver, pry the plastic PC board stop (located at the bottom of the display board) until the bar separates from the casing. Pull the display board from the front panel.
4. Remove the switch pad by pulling it from the front panel.

## Main CPU firmware replacement

Changing the firmware may be necessary as upgrades become available. The firmware revision levels for the main and front panel CPUs are displayed during the power-on sequence. (The main firmware revision level is displayed on the left; the front panel firmware revision level is displayed on the right.) For example, REV: A01 A02 indicates a main firmware revision level of A01 and a front panel firmware revision level of A02.

The firmware for the main CPU is located in the EPROMs U156 (EVEN) and U157 (ODD), leadless ICs that reside in chip carriers on the PC board. To replace the CPU firmware, perform the following:

**WARNING** *Disconnect the instrument from the power lines, and remove the test leads before changing the firmware.*

1. Remove the case cover as described earlier in this section.
2. Locate U156 EVEN and U157 ODD (EPROMs) on the main PC board. They are the only devices installed in chip carriers (sockets).

**CAUTION** *EPROMs U156 and U157 are static-sensitive devices. Be sure to follow the handling precautions explained in Static sensitive devices.*

3. Using an appropriate chip extractor, remove U156 from its chip carrier.
4. Position the new U156 EPROM on the appropriate chip carrier. Make sure the notched corner of the chip is aligned with the notch in the chip carrier.

**NOTE** *Be sure to install the correct EPROMs at the ODD and EVEN locations. The instrument will not function if the EPROMs are installed in the wrong sockets.*

5. With the EPROM properly positioned, push down on the chip until it completely seats into the chip carrier.
6. Repeat steps 3 through 5 for EPROM U157.
7. After installation, make sure the instrument powers up normally before replacing the cover.

## Removing power components

The following procedures for removing the power transformer and/or power module require that the case cover and motherboard be removed, as previously explained.

### Power transformer removal

Perform the following steps to remove the power transformer:

1. Remove motherboard.
2. Unplug the transformer wires that attach to the power module at the rear panel.

During re-assembly, use drawing 2010-050 as a reference and replace the wires as follows:

Top wire:	Gray
Right top:	Violet
Right bottom:	White
Left top:	Red
Left bottom:	Blue

3. Remove the two nuts that secure the transformer to the bottom of the chassis.
4. Pull the black ground wire off the threaded stud, and remove the power transformer from the chassis.

**WARNING** *To avoid electrical shock, which could result in injury or death, the black ground wire of the transformer must be connected to chassis ground. When installing the power transformer, be sure to re-connect the black ground wire to the mounting stud on bottom of the chassis.*

## Power module removal

Perform the following steps to remove the power module:

1. Remove motherboard.
2. Unplug the transformer wires that attach to the power module at the rear panel.

During re-assembly, use drawing 2010-050 as a reference, and replace the wires as follows:

Top wire:	Gray
Right top:	Violet
Right bottom:	White
Left top:	Red
Left bottom:	Blue

3. Disconnect the power module's ground wire. This green and yellow wire connects to a threaded stud on the chassis with a kep nut.
4. Squeeze the latches on either side of the power module while pushing the module from the access hole.

**WARNING** *To avoid electrical shock, which could result in injury or death, the ground wire of the power module must be connected to chassis ground. When installing the power module, be sure to re-connect the green and yellow ground wire to the threaded stud on the chassis.*



## Instrument re-assembly

Re-assemble the instrument by reversing the previous disassembly procedures. Make sure that all parts are properly seated and secured and that all connections are properly made. To ensure proper operation, replace and securely fasten the shield.

**WARNING** *To ensure continued protection against electrical shock, verify that power line ground (green and yellow wire attached to the power module) and the power transformer ground (black wire) are connected to the chassis.*



# 6 Replaceable Parts

## Introduction

This section contains replacement parts information and component layout drawings for the Model 2010.

## Parts lists

The electrical parts lists for the Model 2010 are shown in Tables 4-1 to 4-3. For part numbers to the various mechanical parts and assemblies, use the Miscellaneous parts list and the assembly drawings provided at the end of Section 5 and Tables 6-1 through 6-4.

## Ordering information

To place an order, or to obtain information concerning replacement parts, contact your Keithley representative or the factory (see inside front cover for addresses). When ordering parts, be sure to include the following information:

- Instrument model number (Model 2010)
- Instrument serial number
- Part description
- Component designation (if applicable)
- Keithley part number

## Factory service

If the instrument is to be returned to Keithley Instruments for repair, perform the following:

- Call the Repair Department at 1-800-552-1115 for a Return Material Authorization (RMA) number.
- Complete the service form at the back of this manual, and include it with the instrument.
- Carefully pack the instrument in the original packing carton.
- Write ATTENTION REPAIR DEPARTMENT and the RMA number on the shipping label.

## Component layouts

The component layouts are provided in the following pages:

- Motherboard: 2010-250, pages 1 and 2
- Connector board: 2010-250, pages 1 and 2
- Display board: 2010-110, pages 1 and 2

**Table 6-1**  
Mother board parts list

Circuit desig.	Description	Keithley part no.
AT101	IC, DUAL HIGH CMR/SPEED OPTO, HCPL-2631	IC-588
C101,103,111,116,118,122,124,128,133,135,136,138,139,142,149,152,153,159-163,167-170,173,174,178,180,183,186,187,190,193,197,198,201-208,210,212-218,221,223,225,227,230,232,233,249,250,290,299	CAP, .1UF, 10%, 25V, CERAMIC	C-495-.1
C102	CAP, .01UF, 10%,1000V,CERAMIC	C-64-.01
C104	CAP, 100UF, 20%, 63V, ALUM ELEC	C-403-100
C105	CAP, .22UF, 20%, 400V FILM	C-513-.22
C106	CAP, 15P, 1%, 100V, CERAMIC	C-512-15P
C107,117,147,151,182,185,191,194,199,234,237,259,261-263,279,280,282,283,285-287,291,293,294	CAP, .1UF, 20%,50V, CERAMIC	C-418-.1
C109	CAP, 2.2UF, 20%, 63V, POLYCARB	C-480-2.2
C110,141,150,158,176,219,220,222,224,226,272-275,278,289	CAP, 47P, 5%, 100V, CERAMIC	C-465-47P
C112,248	CAP, .01, 5%, 50V, NPO	C-514-.01
C113,114,119,123,126,245-247	CAP, 1000P, 10%, 100V, CERAMIC	C-451-1000P
C115	CAP, .33UF, 20%, 63V, POLYCARBONATE	C-482-.33
C120	CAP, 270PF, 5%, 100V, CERAMIC	C-465-270P
C131,148	CAP, 1000UF, 20%, 50V, ALUM ELEC	C-469-1000
C132,140	CAP, 220PF, 10%, 100V, CERAMIC	C-451-220P
C137	CAP, 33PF, 5%, 100V, CERAMIC	C-465-33P
C145,240,260,300	CAP, 1000PF, 20%, 50V, CERAMIC	C-418-1000P
C146	CAP, 2200UF, 20%, 16V, ALUM ELEC	C-473-2200
C156	CAP, 6800UF, -20+100%, 16V, ALUMINUM	C-313-6800
C171,177	CAP, 2200P, 10%, 100V, CERAMIC	C-430-2200P
C175	CAP, 10UF,20%, 25V, TANTALUM	C-440-10
C179,308,312	CAP, 100PF, 5%, 100V, CERAMIC	C-465-100P
C209	CAP, 22UF, 20%, 25V, TANTALUM	C-440-22
C241,242,243,270	CAP, .01UF, 10%, 50V, CERAMIC	C-491-.01
C251,258,295	CAP, 100PF, 5%, 100V, CERAMIC	C-465-100P
C252,257,264,266,267,268,271	CAP, 47PF, 10%, 100V, CERAMIC	C-451-47P
C253-256	CAP, .15UF, 20%, 50V, CERAMIC	C-418-.15
C276,277,281,284	CAP, 470UF, 20%, 63V, ALUM ELEC	C-477-470
C288	CAP, .1UF, 10%, 1000V, CERAMIC	C-64-.1

**Table 6-1 (cont.)**  
Mother board parts list

Circuit desig.	Description	Keithley part no.
C296,297	CAP, 47UF, ±20%, 25V, ALUM ELEC	C-314-47
C298	CAP, 100PF, 2.5%, 630V, POLYPROPYLENE	C-405-100P
C306,307	CAP, 680PF, 10%, 1000V, CERAMIC	C-64-680P
CR102,103	DIODE, BRIDGE, VM18	RF-52
CR104	DIODE, SILICON, W04M	RF-46
CR106	DIODE, BRIDGE PE05	RF-48
CR110,118	DIODE, DUAL HSM-2822T31	RF-95
CR111,112,116,117,119,126,133 ,134,142,143	DIODE, DUAL SWITCHING, BAV99L	RF-82
CR120,122	DIODE, DUAL COMMON ANODE BAW56LT2	RF-98
CR121,123,127,128,131	DIODE, SWITCHING, MMBD914	RF-83
CR132	DIODE, HI-VOLTAGE, HV-15	RF-76
CR135-141	DIODE, SWITCHING, MMSD914T19	RF-112
E101,102	SURGE ARRESTOR, CG3-1.5L	SA-4
J1006	CONN, MICRODIN W/GND FINGERS	CS-792
J1007	CONN, RT ANGLE, MALE, 9 PIN	CS-761-9
J1008	CONN, RIGHT ANGLE, 24 PIN	CS-501
J1014	CONN, HEADER STRAIGHT SOLDER PIN	CS-368-16
J1015	CONNECTOR, HEADER	CS-784-4
J1016	CONN, MALE, 5-PIN (MOLEX 42491)	CS-784-5
J1017	CONNECTOR, HEADER STRAIGHT SOLDER PIN	CS-368-14
J1034	CONN, MALE RT ANGLE, 32 PIN	CS-456
K101,102,104	RELAY, MINATURE (DPDT) TQ2E-L2-5V	RL-155
K103	RELAY, MINI SIGNAL REL	RL-163
L101-106	FERRITE CHIP 600 OHM BLM32A07	CH-62
L107,108	CHOKE	CH-61
L109,111	CHOKE, 22UH	CH-66-22
L110	CHOKE, 100UH	CH-14
LS101	BEEPER, 5V, 30MA, BRT1209P-06-C	EM-5
Q101,102,153	TRANS, N-CHAN MOSFET, 2SK1412	TG-276
Q103,112,128,130, 147,171,183	TRANS, NPN, MMBT3904	TG-238
Q104,105,108,109,113,114,121, 123,124,126,135,136,159,167, 185,186,195	TRANS, N CHANNEL JFET, SNJ132199	TG-294
Q119	TRANS, P CHANNEL JFET, J270	TG-166

**Table 6-1 (cont.)**  
 Mother board parts list

Circuit desig.	Description	Keithley part no.
Q125	TRANS, SELECTED TG-128	31841A
Q129,141,166,172	TRANS, PNP, MMBT3906L	TG-244
Q137,138	SELECTION, TG-225	182-600B
Q140,188	TRANS, N-CHAN JFET, SST4393	TG-263
Q142,148	TRANS, NPN COMP SILICON AMP, MPS8099	TG-157
Q143,149	TRANS, PNP COMP SILICON AMP, MPS8599	TG-158
Q144,150	TRANS, NPN SILICON, BC846BL	TG-278
Q145,146	TRANS, PNP, BC 856BL	TG-287
Q151,168,169,175-178	TRANS, N-MOSFET, VN0605T	TG-243
Q154,155	TRANS, N-CHAN MOSFET, TN254ON8	TG-274
Q156	TRANS, DUAL N-CHAN JFET, SNJ450H99	TG-326
Q160	TRANS, NPN PAIR, LM394	TG-142
Q162	TRANS, DUAL PNP, LS352	TG-322
Q163,189,191,192,196	TRANS, PNP, BC860C	TG-323
Q164,165	TRANS, N-CHAN MOSFET, IRF7101	TG-312
Q184	TRANS, N CHANNEL FET, 2N4392	TG-128-1
Q187	TRANS, P-CHAN, MMBFJ175	TG-311
R101,102	RES, 1M, 5%, 125MW, METAL FILM	R-375-1M
R104,105	RES, 549K, .1%, 1/4W, METAL FILM	R-315-549K
R106	RES, 11K, .1%, 1/10W, METAL FILM	R-263-11K
R109,134,329,382	RES, 1K, 1%, 125mW, METAL FILM	R-391-1K
R110,133	RES NET, 9K-1K, MICRO DIVIDER	TF-246-2
R111,122,140,165,182,190,200, 256,272,279,284,288,290,296, 298,299,358,380,391,398,408, 415,426	RES, 1K, 1%, 100MW, THICK FILM	R-418-1K
R112	RES, 100K, 1%, 125mW, METAL FILM	R-391-100K
R115	RES, 1K, .1%, 1W, WIREWOUND	R-249-1K
R117	RES NET, 100K, 9.9M, METAL FILM	TF-251
R118,175,224,263,276,282, 295	RES, 10K, 1%, 100MW, THICK FILM	R-418-10K
R123	RES, 73.2K, 1%, 100MW, THICK FILM	R-418-73.2K
R127,135	RES, 33.2K, 1%, 100MW, THICK FILM	R-418-33.2K
R129	RES, 215, 1%, 100MW, THICK FILM	R-418-215
R130,164,183,186,191,193,315, 340	RES, 100K, 1%, 100MW, THICK FILM	R-418-100K
R137,143,152,154,177,230,343, 349,361-364, 402,424	RES, 49.9K, 1%, 100MW, THICK FILM	R-418-49.9K
R142	RES, 10, 5%, 125MW, METAL FILM	R-375-10
R145,156,161,178,184,187,213,2 48,257,321,322,351	RES, 100, 1%, 100MW, THICK FILM	R-418-100
R146	RES, 1.1M, 5%, 125MW, METAL FILM	R-375-1.1M

**Table 6-1 (cont.)**  
Mother board parts list

Circuit desig.	Description	Keithley part no.
R147	RES, 732K, 1%, 100MW, THICK FILM	R-418-732K
R153	RES NET, 3.6K MICRO DIVIDER	TF-246-1
R155,169,339,387,388,427	RES, 4.99K, 1%, 100MW, THICK FILM	R-418-4.99K
R157,342	RES, 511, 1%, 100MW, THICK FILM	R-418-511
R158	RES, .1, 1%, 2W, 4-TERMINAL MOLDED	R-342-.1
R172	RES, 1M, 1%, 100MW, THICK FILM	R-418-1M
R185,372,385,398	RES, 1K, 1%, 125mW, METAL FILM	R-391-1K
R189	RES, 6.65K, 1%, 125MW, METAL FILM	R-391-6.65K
R194	RES, 644, 1%, 3W, 300V, METAL FOIL	R-449-644
R195	RES, 64.4K, 1%, 3W, 300V, METAL FOIL	R-449-64.4K
R196,212,217,220,221,264	RES, 2.21K, 1%, 100MW, THICK FILM	R-418-2.21K
R201,204,229,231,233, 238,244	RES, 4.75K, 1%, 100MW, THICK FILM	R-418-4.75K
R202,319,327,328,337,338,389, 390,433,445	RES, 10K, 1%, 100MW, THICK FILM	R-418-10K
R205	RES, 10, .5%, 1/8W, METAL FILM	R-246-10
R214,218,422,441	RES, 2K, 1%, 100MW, THICK FILM	R-418-2K
R215	RES, 49.9K, 1%, 125MW, METAL FILM	R-391-2.87K
R216	RES, 2.49K, 1%, 125MW, METAL FILM	R-391-2.49K
R225,283	RES, 470, 5%, 125MW, METAL FILM	R-375-470
R226,228,235,237,245, 250,252, 255	RES, 475, 1%, 100MW, THICK FILM	R-418-475
R234	RES, 5.11K, 1%, 100MW, THICK FILM	R-418-5.11K
R241	RES, 34K, 1%, 100MW, THICK FILM	R-418-34K
R243,259,317,320	RES, 10, 10%, 100MW, THICK FILM	R-418-10
R246	RES, 82.5, 1%, 100MW, THICK FILM	R-418-82.5
R249	RES, 4.02K, 1%, 100MW, THICK FILM	R-418-4.02K
R261	RES, 200, 1%, 100MW, THICK FILM	R-418-200
R267,270	RES, .0499, 1%, 100MW, THICK FILM	R-418-.0499
R271	RES NET (SOIC)	TF-245
R277	RES, 66.5K, 1%, 100MW, THICK FILM	R-418-66.5K
R278,281,297	RES, 357, 1%, 100MW, THICK FILM	R-418-357
R280,294	RES, 49.9, 1%, 100MW, THICK FILM	R-418-49.9
R287,459	RES, 1.28M, .1%, 1/8W, METAL FILM	R-176-1.28M
R291,292	RES, 47.5K, 1%, 100MW, THICK FILM	R-418-47.5K
R300	RES, 6.04K, 1%, 125MW, THIN FILM	R-423-6.04K
R304	RES, 20K, 1%, 125MW, METAL FILM	R-391-20K
R318	RES, 73.2K, 1%, 100MW, THICK FILM	R-418-73.2K
R324,367	RES, 4.99K, 1%, 125mW, METAL FILM	R-391-4.99K
R325	RES, 200K, 1%, 125MW, METAL FILM	R-391-200K
R326,370	RES, 499, 1%, 125MW, METAL FILM	R-391-499
R330	RES, 22K, 5%, 125MW, METAL FILM	R-375-22K



**Table 6-1 (cont.)**  
**Mother board parts list**

<b>Circuit desig.</b>	<b>Description</b>	<b>Keithley part no.</b>
R331	RES, 1.8M, 5%, 125MW, METAL FILM	R-375-1.8M
R332,365	RES, 499, 1%, 125MW, METAL FILM	R-391-499
R333,334,336	RES, 2.49K, 1%, 125MW, METAL FILM	R-391-2.49K
R335,400	RES, 20, 1%, 100MW, THICK FILM	R-418-20
R341,344	RES, 3.01K, 1%, 100MW, THICK FILM	R-418-3.01K
R345	RES, 511, 1%, 100MW, THICK FILM	R-418-511
R350	RES, 75K, 1%, 100MW THICK FILM	R-418-75K
R353	RES, 332, 1%, 100MW, THICK FILM	R-418-332
R359	RES, 3.01K, 1%, 125MW, METAL FILM	R-391-3.01K
R360	RES, 301, 1%, 100MW, THICK FILM	R-418-301
R366,373	RES, 5K, .1%, WIREWOUND	R-249-5K
R368	RES, 169, .1%, 1/2W, 350V, METAL FILM	R-94-169
R371,392,421	RES, 15k, 1%, 100MW, THICK FILM	R-418-15K
R384	RES, 24.9K, 1%, 100MW, THICK FILM	R-418-24.9K
R386	RES, .91, .1, 1/4W, WIREWOUND	R-95-.91
R405,407	RES, 560K, 5%, 250MW, METAL FILM	R-376-560K
R406	RES, 18.7, 1%, 125mW, METAL FILM	R-391-18.7
R412	RES, 33, 5%, 250mW, METAL FILM	R-376-33
R413	RES, 20K, 1%, 100MW, THICK FILM	R-418-20K
R414	RES, 2.2M, 10%, 1/2W, 1.5KV, METAL OXIDE	R-367-2.2M
R419	RES, 137, 1%, 125MW, METAL FILM	R-391-121
R423	RES, 4.02K,1%,100MW, THICK FILM	R-418-4.02K
R425,446	RES, 49.9K, 1%, 100MW, THICK FILM	R-418-49.9K
R428	RES, 1.87K, .1%, 1/8W, METAL FILM	R-377-1.87K
R429	RES, 200, .1%, 1/10W, METAL FILM	R-263-200
R430	RES, 100K, 1%, 100MW, THICK FILM	R-418-100K
R431	RES, 18K, .1%, 1/10W, METAL FILM	R-263-18K
R444	RES, 24K, 5%, 1W, 200V, THICK FILM	R-437-24K
R450	RES, 100, .1%, 1/10W, METAL FILM	R-263-100
S101	SWITCH, PUSHBUTTON, 8 POLE	SW-468
TP102-106	CONN,TEST POINT	CS-553
U101	IC, VOLTAGE REG LM317M	IC-846
U102,118	IC, J-FET, OP-AMP, TLE2081CD	IC-967
U103,105,111	IC, CMOS ANALOG SWITCH DG211DY	IC-768
U104,170,171	IC, MOSFET DRIVER, TLP591B	IC-877
U106,109,121,130, 134,182	IC, 8 STAGE SHIFT/STORE, MC14094BD	IC-772
U107,108,172	IC, PHOTO, DARLINGTON TRANS	IC-911
U110	IC,TRMS TO DC CONVERTER, 637JR	IC-796
U112	IC, J-FET OP-AMP LF357M	IC-966

**Table 6-1 (cont.)**  
Mother board parts list

Circuit desig.	Description	Keithley part no.
U114,168,173	IC, DUAL J-FET OP-AMP, OP-282GS	IC-968
U115,120	IC, QUAD COMPARATOR, LM339D	IC-774
U116	IC, DARLINGTON ARRAY, ULN2003L	IC-969
U117,145	IC, VOLT. COMPARATOR, LM311M	IC-776
U123	IC, DUAL PICOAMP OP-AMP AD706JR	IC-910
U124	IC, +5V REGULATOR, 500mA,7805	IC-93
U131,178	IC, VOLT COMPARATOR LM393D	IC-775
U133,176	IC, CMOS ANAL SWITCH, DG444DY	IC-866
U135	IC, 16BIT MICROPROCESSOR MC68306FC16	LSI-154
U136	IC, SERIAL EPROM 24LC16B	LSI-153
U137,184	IC, OP-AMP, AD744KR	IC-1068
U138	INTEGRATED CIRCUIT, OPA177GS	IC-960
U139,166	IC, DUAL BIPOLAR OP-AMP, LT1124CS8	IC-955
U141	IC, PRECISION REFERENCE, LM399	196-600A
U142	IC, OP-AMP, NE5534D	IC-802
U144	IC, LOW DROPOUT REGULATOR, LM295T	IC-962
U146	IC,POS NAND GATES/INVERT, 74HCT14	IC-656
U147,164,192	IC, DUAL D-TYPE F/F, 74HC74	IC-773
U148,153	IC, QUAD 2 IN NOR, 74HCT02	IC-809
U149	IC, NCHAN LAT DMOS QUADFET, SD5400CY	IC-893
U150,155	IC, OPTOCOUPLER, 2601	IC-239
U151,152	IC, 32KX8 STAT CMOS RAM, D43256C	LSI-93-100
U154	IC, QUAD D FLIP FLOP W/CLK, RESET 74HC175	IC-923
U156	PROGRAMMED ROM	2010-804-*
U157	PROGRAMMED ROM	2010-803-*
U158	IC, GPIB ADAPTER, 9914A	LSI-123
U159	IC, +5V RS-232 TRANSCEIVER, MAX202	IC-952
U160	IC,OCTAL INTERFACE BUS, 75160	IC-646
U161	IC,OCTAL INTER BUS TRANS, 75161	IC-647
U163	IC, 8-CHAN ANA MULTIPLEXER, DG408DY	IC-844
U165	PROGRAMMED IC	2000-802-*
U167	IC, OP-AMP, LTC1050CS8	IC-791
U174,177	IC, OP-AMP, MC34081BD	IC-1058
U179	IC, NEG VOLTAGE REG -15V, 500MA, 79M15	IC-195
U180	IC, POS VOLTAGE REG +15V, 500MA, 7815	IC-194
U185	IC, AJD SHUNT REGULATOR, TL431CLP	IC-677
U187	IC, PROGRAMMABLE, PRECISION-REF TL431CD	IC-1042
U188,189	IC, PHOTO TRANS, TLP626BV-LFI	IC-1006
U190	IC, OP-AMP, AD707	IC-712

**Table 6-1 (cont.)**  
*Mother board parts list*

<b>Circuit desig.</b>	<b>Description</b>	<b>Keithley part no.</b>
VR103,104	DIODE, ZENER, 6.8V, MMSZ5235BT1	DZ-100
VR105,106	DIODE, ZENER, 11V, MMSZ11T1	DZ-103
VR112,113	DIODE, ZENER, 6.2V, MMSZ6V2	DZ-97
VR115,121	DIODE, ZENER, 5.1V, BZX84C5V1	DZ-88
VR116,119	DIODE, ZENER, 3.3V, MMBZ5226BL	DZ-94
VR120,VR102	DIODE, ZENER, 6.2V, BZX84B6V2	DZ-87
VR122	DIODE, ZENER, 6.4V, IN4579	DZ-73
VR123,124	DIODE, ZENER, 12V, MMSZ11T1	DZ-112
VR125,126	DIODE, ZENER, 7.5V, BZX84C7V5	DZ-110
Y101	CRYSTAL, 14.7456MHZ	CR-39
Y102	OSCILLATOR HIGH SPEED CMOS 12MHZ	CR-37

\* Order same type as existing firmware revision level.

**Table 6-2**  
Display board parts list

Circuit desig.	Description	Keithley part no.
C413	CAP, 22UF, 20%, 6.3, TANTALUM	C-417-22
C401,402,411	CAP, .1UF, 20%, 50V, CERAMIC	C-418-.1
C406,408	CAP, 33PF, 10%, 100V, CERAMIC	C-451-33P
C414	CAP, 47PF, 10%, 100V, CERAMIC	C-451-47P
C403-405,407,409, 410,412	CAP, .1UF, 10%, 25V, CERAMIC	C-495-.1
CR401,402	DIODE, MBR0520LT1	RF-103
DS401	DISPLAY	DD-52
P1014	CABLE ASSEMBLY	CA-123-16A
R419	RES, 10M, 5%, 125MW, METAL FILM	R-375-10M
R405,408,410,412	RES, 12.1, 1%, 125MW, METAL FILM	R-391-12.1
R420,421	RES, 10K, 1%, 100MW, THICK FILM	R-418-10K
R413	RES, 13K, 1%, 100MW, THICK FILM	R-418-13K
R401-404,406,409, 411,415,416	RES, 15K, 1%, 100MW, THICK FILM	R-418-15K
U401	PROGRAMMED ROM	2000-800-*
U402,403	IC, LATCHED DRIVERS, UCN-5812EPF-1	IC-732
	IC, 8-BIT MICROCON, MC68HC705C8P(PLCC)	LSI-105
Y401	CRYSTAL, 4MHZ	CR-36-4

\* Order current firmware revision level.

**Table 6-3**  
Connector board parts list

Circuit desig.	Description	Keithley part no.
C101	CAP, .1UF, 10%, 25V, CERAMIC	C-495-.1
C302-305	CAP, 47P, 5%, 100V, CERAMIC	C-465-47P
J1034	CONN, MALE RT ANGLE, 32-PIN	CS-456
P1017	CABLE ASSEMBLY	CA-123-14A
R196	RES, 2.21K, 1%, 100MW, THICK FILM	R-418-2.21K

**Table 6-4**  
Mechanical parts list

Description	Keithley part no.
BANANA JACK, PUSH-IN, BLACK	BJ-13-0
BANANA JACK, PUSH-IN, RED	BJ-13-2
BEZEL, REAR	428-303D
CARD GUIDE/SHIELD	2000-311A
CHASSIS	2000-305
CHASSIS ASSEMBLY	2000-309F
CHASSIS ASSEMBLY	2010-MECH-6
CONTACT, CURRENT INPUT	2001-313C
COVER	2000-307C
COVER PANEL, SCANNER	2001-372A
DISPLAY LENS	2010-304A
FOOT	428-319A
FOOT, EXTRUDED	FE-22A
FOOT, RUBBER	FE-6
FRONT PANEL	2001-302G
FRONT PANEL OVERLAY	2000-303A
FRONT PANEL PRINTED	2010-301A
FRONT/REAR SWITCH ROD	2001-322A
FUSE HOLDER	FH-35-1
FUSE 0.25A	FU-96-4
FUSE, 3A, 250	FU-99-1
JACK, CURRENT INPUT	2001-312D
JACK, CURRENT INPUT	V-2001-312D
LINE MODULE	PM-1-1B
MOTHERBOARD SHIELD	2000-306B
MOUNTING EAR, LEFT	428-338B
MOUNTING EAR, RIGHT	428-328E
POWER ROD	2001-320A
REAR PANEL	2000-308
SWITCHPAD	2000-310A
TRANSFORMER	TR-299B
WIRE, 16GA GRN/YEL	SC-73-5

---

# A Specifications

## DC CHARACTERISTICS

CONDITIONS: MED (1 PLC)<sup>1</sup> or SLOW (5 PLC)

ACCURACY: ±(ppm of reading + ppm of range)  
(ppm = parts per million) (e.g., 10ppm = 0.001%)

FUNCTION	RANGE	RESOLUTION	INPUT		TEMPERATURE COEFFICIENT					
			TEST CURRENT OR BURDEN VOLTAGE	RESISTANCE OR CLAMP VOLTAGE	24 Hour <sup>13</sup> 23°C±1°	90 Day 23°C±5°	1 Year 23°C±5°	2 Years 23°C±5°	0°-18°C & 28°-50°C	
<b>Voltage</b>	100.00000 mV <sup>17</sup>	10 nV		> 10 GΩ	10 + 9	25 + 9	37 + 9	50 + 10	2 + 6	
	1.0000000 V	100 nV		> 10 GΩ	7 + 2	18 + 2	25 + 2	32 + 2	2 + 1	
	10.000000 V	1 μV		> 10 GΩ	7 + 4	18 + 4	24 + 4	32 + 4	2 + 1	
	100.00000 V	10 μV		10 MΩ ±1%	10 + 4	25 + 5	35 + 5	52 + 5	5 + 1	
	1000.0000 V <sup>8</sup>	100 μV		10 MΩ ±1%	17 + 6	31 + 6	41 + 6	55 + 6	5 + 1	
<b>Resistance<sup>14</sup></b>	10.000000 Ω	1 μΩ	10 mA		15 + 9	40 + 9	60 + 9	100 + 10	8 + 6	
	100.00000 Ω	10 μΩ	1 mA		15 + 9	36 + 9	52 + 9	90 + 10	8 + 6	
	1.0000000 kΩ	100 μΩ	1 mA		15 + 2	33 + 2	50 + 2	80 + 2	8 + 1	
	10.000000 kΩ	1 mΩ	100 μA		15 + 2	32 + 2	50 + 2	80 + 2	8 + 1	
	100.00000 kΩ	10 mΩ	10 μA		15 + 2	40 + 2	70 + 2	120 + 2	8 + 1	
	1.0000000 MΩ	100 mΩ	10 μA		20 + 3	50 + 4	70 + 4	125 + 4	8 + 1	
	10.000000 MΩ <sup>10</sup>	1 Ω	640 nA // 10MΩ		150 + 4	200 + 4	400 + 4	500 + 4	25 + 1	
	100.00000 MΩ <sup>10</sup>	10 Ω	640 nA // 10MΩ		800 + 4	1500 + 4	1500 + 4	1800 + 4	150 + 1	
	<b>Dry Circuit Resistance</b>	10.00000 Ω <sup>15</sup>	10 μΩ	1 mA	20 mV	25 + 90	50 + 90	70 + 90	120 + 90	8 + 60
		100.0000 Ω	100 μΩ	100 μA	20 mV	25 + 90	50 + 90	70 + 90	120 + 90	8 + 60
<b>Current</b>	10.000000 mA	10 nA	< 0.15 V		60 + 15	300 + 40	500 + 40	740 + 40	50 + 5	
	100.00000 mA	100 nA	< 0.18 V		100 + 15	300 + 40	500 + 40	740 + 40	50 + 5	
	1.0000000 A	1 μA	< 0.35 V		200 + 15	500 + 40	800 + 40	1200 + 40	50 + 5	
	3.000000 A	10 μA	< 1 V		1000 + 10	1200 + 15	1200 + 15	1800 + 15	50 + 5	
<b>Continuity 2W</b>	1 kΩ	100 mΩ	1 mA		40 + 100	100 + 100	120 + 100	190 + 10	8 + 1	
<b>Diode Test</b>	10.000000 V	1 μV	1 mA		20 + 6	30 + 7	40 + 7	55 + 7	8 + 1	
	4.400000 V	1 μV	100 μA		20 + 6	30 + 7	40 + 7	55 + 7	8 + 1	
	10.000000 V	1 μV	10 μA		20 + 6	30 + 7	40 + 7	55 + 7	8 + 1	
<b>DCV:DCV Ratio<sup>16</sup></b>	100 mV to 1000 V				Ratio accuracy = accuracy of selected sense input range + accuracy of selected input range.					

## DC NOISE PERFORMANCE

RATE	DIGITS	RMS NOISE 100mV RANGE		RMS NOISE 10V RANGE		NMRR <sup>11</sup>	CMRR <sup>12</sup>
		10 seconds	2 minutes	10 seconds	2 minutes		
5 PLC	7½	100 nV	110 nV	1.1 μV	1.2 μV	60 dB	140 dB
1 PLC	6½	120 nV	125 nV	1.3 μV	1.4 μV	60 dB	140 dB
0.1 PLC	5½	1.5 μV	1.6 μV	11 μV	11.5 μV	—	80 dB
0.01 PLC	4½	3.0 μV	2.9 μV	135 μV	139 μV	—	80 dB

## DC OPERATING CHARACTERISTICS<sup>3</sup>

FUNCTION	DIGITS	READINGS/s	PLC's <sup>7</sup>
DCV (all ranges),	7½ <sup>2</sup>	4 (3)	5
DCI (all ranges), and	6½ <sup>2,6</sup>	30 (27)	1
Ohms (<10M range)	6½ <sup>2,4</sup>	50 (44)	1
	5½ <sup>2,4</sup>	260 (220)	0.1
	5½ <sup>4</sup>	490 (440)	0.1
	5½ <sup>4</sup>	1000 (1000)	0.04
	4½ <sup>4</sup>	2000 (1800)	0.01

## DC SYSTEM SPEEDS<sup>3, 5</sup>

RANGE CHANGE<sup>2</sup>: 50/s (42/s).  
 FUNCTION CHANGE<sup>2</sup>: 45/s (38/s).  
 AUTORANGE TIME<sup>2,9</sup>: <30ms (<35ms).  
 ASCII READINGS TO RS-232 (19.2K BAUD): 55/s (55/s).  
 MAX. INTERNAL TRIGGER RATE: 2000/s (2000/s).  
 MAX. EXTERNAL TRIGGER RATE: 480/s (480/s).  
 RATIO SPEED<sup>2,3</sup>: 10/s (8/s).

**DC GENERAL**

**LINEARITY OF 10VDC RANGE:** ±(2ppm of reading + 1ppm of range).  
**DCV, Ω, TEMPERATURE, CONTINUITY, DIODE TEST INPUT PROTECTION:** 1000V, all ranges.  
**MAXIMUM 4WΩ LEAD RESISTANCE:** 5% of range per lead for 10Ω, 100Ω and 1kΩ ranges; 1kΩ per lead for all other ranges.  
**DC CURRENT INPUT PROTECTION:** 3A, 250V fuse.  
**SHUNT RESISTOR:** 0.1Ω for 3A and 1A ranges. 1Ω for 100mA range. 10Ω for 10mA range.  
**CONTINUITY THRESHOLD:** Adjustable 1Ω to 1000Ω.  
**OVERRANGE:** 120% of range except on 1000V, 3A and Diode.  
**OFFSET COMPENSATION:** Available for 10kΩ and lower ranges only.

**DC NOTES**

- For the following ranges, add 4ppm to the range accuracy specification: 100mV, 10Ω, 100Ω, 10mA, 100mA and 1A. Dry circuit function add 40ppm.
- Speeds include measurement and binary data transfer out the GPIB.
- Speeds are for 60Hz (50Hz) operation using factory default operating conditions (\*RST). Autorange off, Display off, Trigger delay = 0.
- Sample count = 1024, auto zero off.
- Auto zero off, NPLC = 0.01.
- Ohms, 17 (15) readings/second.
- 1 PLC = 16.67ms @ 60Hz, 20ms @ 50Hz/400Hz. The frequency is automatically determined at power up.
- For signal levels >500V, add 0.02ppm/V uncertainty for the portion exceeding 500V.
- Add 120ms for ohms.
- Must have 10% matching of lead resistance in Input HI and LO.
- For line frequency ±0.1%.
- For 1kΩ unbalance in LO lead.
- Relative to calibration accuracy.
- Specifications are for 4-wire ohms or 2-wire ohms with REL function. 10Ω range is for 4-wire only.
- Offset compensation on.
- Sense LO input must be referenced to Input LO. Sense HI input must not exceed 125% (referenced to Input LO) of range selected. Sense input has 100mV, 1V and 10V ranges.
- When properly zeroed using REL function.

**TRUE RMS AC VOLTAGE AND CURRENT CHARACTERISTICS**

ACCURACY<sup>1</sup>: ±(% of reading + % of range), 23°C ±5 °C

VOLTAGE RANGE	RESOLUTION	CALIBRATION CYCLE	3 Hz– 10 Hz	10 Hz– 20 kHz	20 kHz– 50 kHz	50 kHz– 100 kHz	100 kHz– 300 kHz
100.0000 mV	0.1 μV	90 Days	0.35 + 0.03	0.05 + 0.03	0.11 + 0.05	0.60 + 0.08	4 + 0.5
1.000000 V	1.0 μV						
10.00000 V	10 μV	1 Year	0.35 + 0.03	0.06 + 0.03	0.12 + 0.05	0.60 + 0.08	4 + 0.5
100.0000 V	100 μV						
750.000 V	1 mV						
<b>TEMPERATURE COEFFICIENT<sup>8</sup></b>			0.035 + 0.003	0.005 + 0.003	0.006 + 0.005	0.01 + 0.006	0.03 + 0.01
CURRENT RANGE	RESOLUTION	CALIBRATION CYCLE	3 Hz - 10 Hz	10 Hz - 5 kHz			
1.000000 A	1 μA	90 Day/1 Year	0.30 + 0.04	0.10 + 0.04			
3.00000 A	10 μA	90 Day/1 Year	0.35 + 0.06	0.15 + 0.06			
<b>TEMPERATURE COEFFICIENT<sup>8</sup></b>			0.035 + 0.006	0.015 + 0.006			

**HIGH CREST FACTOR ADDITIONAL ERROR ±(% of reading)<sup>7</sup>**

<b>CREST FACTOR:</b>	1–2	2–3	3–4	4–5
<b>ADDITIONAL ERROR:</b>	0.05	0.15	0.30	0.40

**AC OPERATING CHARACTERISTICS<sup>2</sup>**

FUNCTION	DIGITS	READINGS/s	RATE	BANDWIDTH
ACV (all ranges), and ACI (all ranges)	6½ <sup>3</sup>	0.5 (0.4)	SLOW	3 Hz–300 kHz
	6½ <sup>3</sup>	1.4 (1.5)	MED	30 Hz–300 kHz
	6½ <sup>4</sup>	4.0 (4.3)	MED	30 Hz–300 kHz
	6½ <sup>3</sup>	2.2 (2.3)	FAST	300 Hz–300 kHz
	6½ <sup>4</sup>	35 (30)	FAST	300 Hz–300 kHz



**ADDITIONAL LOW FREQUENCY ERRORS ±(% of reading)**

	<b>SLOW</b>	<b>MED</b>	<b>FAST</b>
20Hz – 30Hz	0	0.3	—
30Hz – 50Hz	0	0	—
50Hz – 100Hz	0	0	1.0
100Hz – 200Hz	0	0	0.18
200Hz – 300Hz	0	0	0.10
> 300Hz	0	0	0

**AC SYSTEM SPEEDS <sup>2, 5</sup>**

**FUNCTION/RANGE CHANGE <sup>6</sup>:** 4 / s.

**AUTORANGE TIME:** <3 s.

**ASCII READINGS TO RS-232 (19.2K BAUD) <sup>4</sup>:** 50 / s.

**MAX. INTERNAL TRIGGER RATE <sup>4</sup>:** 300 / s.

**MAX. EXTERNAL TRIGGER RATE <sup>4</sup>:** 300 / s.

**AC GENERAL**

**INPUT IMPEDANCE:** 1MΩ ±2% paralleled by <100pF.

**ACV INPUT PROTECTION:** 1000V.

**MAXIMUM DCV:** 400V on any ACV range.

**ACI INPUT PROTECTION:** 3A, 250V fuse.

**BURDEN VOLTAGE:** 1A Range: <0.35V rms. 3A Range: <1V rms.

**SHUNT RESISTOR:** 0.1Ω on all ACI ranges.

**AC CMRR:** >70dB with 1kΩ in LO lead.

**MAXIMUM CREST FACTOR:** 5 at full scale.

**VOLT HERTZ PRODUCT:** ≤8 × 10<sup>7</sup> V·Hz.

**OVERRANGE:** 120% of range except on 750V and 3A ranges.

**AC NOTES**

- Specifications are for SLOW rate and sinewave inputs >5% of range.
- Speeds are for 60Hz (50Hz) operation using factory default operating conditions (\*RST). Auto zero off, Auto range off, Display off, includes measurement and binary data transfer out the GPIB.
- 0.01% of step settling error. Trigger delay = 400ms.
- Trigger delay = 0.
- DETECTOR: BANDwidth 300, NPLC = 0.01.
- Maximum useful limit with trigger delay = 175ms.
- Applies to non-sinewaves >5Hz.
- Applies to 0°–18°C and 28°–50°C.

**FREQUENCY AND PERIOD CHARACTERISTICS <sup>1,2</sup>**

<b>ACV RANGE</b>	<b>FREQUENCY RANGE</b>	<b>PERIOD RANGE</b>	<b>GATE TIME</b>	<b>RESOLUTION ±(ppm of reading)</b>	<b>ACCURACY 90 Day/1 Year ±(% of reading)</b>
100 mV	3 Hz	333 ms	1 s	0.3	0.01
to	to	to			
750 V	500 kHz	2 μs			

**FREQUENCY NOTES**

- Specifications are for sinewave inputs >10% of ACV range, except 100mV range. On 100mV range frequency must be >10Hz if voltage is <20mV.
- 20% overrange on all ranges except 750V range.

## TEMPERATURE CHARACTERISTICS

### THERMOCOUPLE<sup>2,3,4</sup>

90 Day/1 Year (23°C ± 5°C)

#### ACCURACY<sup>1</sup>

TYPE	RANGE	RESOLUTION	ACCURACY <sup>1</sup>	
			Relative to Simulated Reference Junction	Using 2001-TCSCAN <sup>5</sup>
J	-200 to + 760°C	0.001°C	±0.5°C	±0.65°C
K	-200 to + 1372°C	0.001°C	±0.5°C	±0.70°C
N	-200 to + 1300°C	0.001°C	±0.5°C	±0.70°C
T	-200 to + 400°C	0.001°C	±0.5°C	±0.68°C

### 4-WIRE RTD<sup>2,3,7,8</sup>

90 Day/1 Year (23°C ± 5°C)

2 Year (23°C ± 5°C)

RANGE	RESOLUTION	ACCURACY <sup>6</sup>	ACCURACY <sup>6</sup>
-100° to +100°C	0.001°C	±0.08°C	±0.12°C
-200° to +630°C	0.001°C	±0.14°C	±0.18°C

## TEMPERATURE NOTES

- For temperatures <-100°C, add ±0.1°C and >900°C add ±0.3°C.
- Temperature can be displayed in °C, K or °F.
- Accuracy based on ITS-90.
- Exclusive of thermocouple error.
- Specifications apply to channels 2-6. Add 0.6°C/channel from channel 6.
- Excluding probe errors.
- 100Ω platinum, D100, F100, PT385, PT-3916 or user type.
- Maximum lead resistance (each lead) to achieve rated accuracy is 5Ω.

## INTERNAL SCANNER SPEED

### MAXIMUM INTERNAL SCANNER RATES:

RANGE: Channels/s<sup>1</sup>

TRIGGER DELAY = 0

DCV <sup>2</sup>	ACV <sup>2,3</sup>	2 WIRE OHMS <sup>2</sup>	4 WIRE OHMS <sup>2</sup>	T/C TEMPERATURE <sup>2</sup>	RTD TEMPERATURE <sup>2</sup>
All : 105	All : 96	All : 102	<10MΩ : 55	All : 70	All : 2

TRIGGER DELAY = AUTO

DCV <sup>2</sup>	ACV <sup>2,3</sup>	2 WIRE OHMS <sup>2</sup>	4 WIRE OHMS <sup>2</sup>	T/C TEMPERATURE <sup>2</sup>	RTD TEMPERATURE <sup>2</sup>
0.1 V : 100	All : 1.8	100 Ω : 82	100 Ω : 42	All : 70	All : 2
1 V : 100		1 kΩ : 85	1 kΩ : 42		
10 V : 100		10 kΩ : 42	10 kΩ : 25		
100 V : 70		100 kΩ : 28	100 kΩ : 21		
1000 V : 70		1 MΩ : 8	1 MΩ : 7		
		10 MΩ : 5	10 MΩ : 5		
		100 MΩ : 3	100 MΩ : 3		

## INTERNAL SCANNER SPEED NOTES

- Speeds are for 60Hz or 50Hz operation using factory default operating conditions (\*RST). Auto Zero off, Auto Range off, Display off, sample count = 1024.
- NPLC = 0.01.
- DETECTOR BANDwidth: 300.

## GENERAL INFORMATION

### GENERAL SPECIFICATIONS

**POWER SUPPLY:** 100V / 120V / 220V / 240V  $\pm$ 10%.

**LINE FREQUENCY:** 45Hz to 66Hz and 360Hz to 440Hz, automatically sensed at power-up.

**POWER CONSUMPTION:** 22VA.

**OPERATING ENVIRONMENT:** Specified for 0°C to 50°C. Specified to 80% R.H. at 35°C.

**STORAGE ENVIRONMENT:** -40°C to 70°C.

**WARRANTY:** 3 years.

**SAFETY:** Designed to UL-3111-1, IEC-1010-1.

**EMC:** Complies with European Union Directive 89/336/EEC (CE marking requirements), FCC part 15 class B, CTSPR 11, IEC 801-2, IEC 801-3, IEC 801-4.

**VIBRATION:** MIL-T-28800E Type III, Class 5.

**WARMUP:** 2 hours to rated accuracy.

**DIMENSIONS: Rack Mounting:** 89mm high x 213mm wide x 370mm deep (3½ in x 8¾ in x 14⅞ in).

**Bench Configuration (with handle and feet):** 104mm high x 238mm wide x 370mm deep (4⅛ in x 9⅜ in x 14⅞ in).

**SHIPPING WEIGHT:** 5kg (11 lbs).

**VOLT HERTZ PRODUCT:**  $\leq 8 \times 10^7$ V·Hz.

### TRIGGERING AND MEMORY

**READING HOLD SENSITIVITY:** 0.01%, 0.1%, 1%, or 10% of reading.

**TRIGGER DELAY:** 0 to 99 hrs (1ms step size).

**EXTERNAL TRIGGER DELAY:** <1ms.

**EXTERNAL TRIGGER JITTER:** <500µs.

**MEMORY:** 1024 readings.

### MATH FUNCTIONS

Rel, Min/Max/Average/StdDev (of stored reading), dB, dBm, Limit Test, %, and mX+b with user defined units displayed.

**dBm REFERENCE RESISTANCES:** 1 to 9999Ω in 1Ω increments.

### REMOTE INTERFACE

Keithley 199/196 Emulation

GPIO (IEEE-488.2) and RS-232C

SCPI (Standard Commands for Programmable Instruments)

### ACCESSORIES SUPPLIED

Model 1751 Safety Test Leads

User Manual

Service Manual

### ACCESSORIES AVAILABLE

<b>Model 1050:</b>	Padded Carrying Case with handle and shoulder strap
<b>Model 1754:</b>	Universal Test Lead Kit
<b>Model 2000-SCAN:</b>	10-Channel Scanner
<b>Model 2001-TCSCAN:</b>	9-Channel Thermocouple Scanner (includes 1-channel reference junction)
<b>Model 2010-EW:</b>	One Year Warranty Extension
<b>Model 4288-1:</b>	Single Fixed Rack Mount Kit
<b>Model 4288-2:</b>	Dual Fixed Rack Mount Kit
<b>Model 5804:</b>	4-Terminal Test Lead Set
<b>Model 5805:</b>	Kelvin Probes
<b>Model 5806:</b>	Kelvin Clip Lead Set
<b>Model 5807-7:</b>	Helical Spring Point Test Leads
<b>Model 7007-1:</b>	Shielded GPIB Cable, 1m (3.2 ft)
<b>Model 7007-2:</b>	Shielded GPIB Cable, 2m (6.5 ft)
<b>Model 7009-5:</b>	Shielded RS-232 Cable, 1.5m (5 ft.)
<b>Model 8502:</b>	Trigger-Link Adapter to 6 female BNC connector
<b>Model 8503:</b>	Trigger-Link Cable to 2 male BNCs, 1m (3.2 ft)
<b>Model 8605:</b>	High Performance Modular Test Leads
<b>Model 8606:</b>	High Performance Probe Tip Kit

Specifications subject to change without notice.

## Accuracy calculations

The following information discusses how to calculate accuracy for both DC and AC characteristics.

### Calculating DC characteristics accuracy

DC characteristics accuracy is calculated as follows:

$$\begin{aligned} \text{Accuracy} &= \pm(\text{ppm of reading} + \text{ppm of range}) \\ (\text{ppm} &= \text{parts per million, and } 10\text{ppm} = 0.001\%) \end{aligned}$$

As an example of how to calculate the actual reading limits, assume that you are measuring 5V on the 10V range. You can compute the reading limit range from one-year DCV accuracy specifications as follows:

$$\begin{aligned} \text{Accuracy} &= \pm(24\text{ppm of reading} + 4\text{ppm of range}) \\ &\pm[(24\text{ppm} \times 5\text{V}) + (4\text{ppm} \times 10\text{V})] \\ &\pm(120\mu\text{V} + 40\mu\text{V}) \\ &\pm 160\mu\text{V} \end{aligned}$$

Thus, the actual reading range is  $5\text{V} \pm 160\mu\text{V}$  or from 4.99984V to 5.00016V

DC current and resistance calculations are performed in exactly the same manner using the pertinent specifications, ranges, and input signal values.

### Calculating AC characteristics accuracy

AC characteristics accuracy is calculated similarly, except that AC specifications are given as follows:

$$\text{Accuracy} = \pm(\% \text{ of reading} + \% \text{ of range})$$

As an example of how to calculate the actual reading limits, assume that you are measuring 120V, 60Hz on the 750V range. You can compute the reading limit range from ACV one-year accuracy specifications as follows:

$$\begin{aligned} \text{Accuracy} &= \pm(0.06\% \text{ of reading} + 0.03\% \text{ of range}) \\ &\pm[(0.0006 \times 120\text{V}) + (0.0003 \times 750\text{V})] \\ &\pm(0.072\text{V} + 0.225\text{V}) \\ &\pm 0.297\text{V} \end{aligned}$$

In this case, the actual reading range is  $20\text{V} \pm 0.297\text{V}$  or from 119.703V to 120.297V

AC current calculations are performed in exactly the same manner using the pertinent specifications, ranges, and input signal values.

### **Additional derating factors**

In some cases, additional derating factors must be applied to calculate certain accuracy values. For example, an additional derating factor of 0.02ppm/V must be added to DCV specifications for voltages over 500V. Before calculating accuracy, study the associated specifications very carefully to see if any derating factors apply.



**B**  
Calibration  
Command Reference

## Introduction

This appendix contains detailed information about the various Model 2010 remote calibration commands. Section 2 of this manual covers detailed calibration procedures. For information about additional commands to control other instrument functions, refer to the Model 2010 User's Manual.

## Command summary

Table B-1 summarizes Model 2010 calibration commands.

**Table B-1**  
*Remote calibration command summary*

Command	Description
:CALibration :PROTected  :CODE '<up to 8 char. string>' :COUNT? :INITiate :LOCK  :LOCK? :SAVE :DATE <year>, <month>, <day> :DATE? :NDUE <year>, <month>, <day> :NDUE?	Calibration root command. All commands in this subsystem are protected by the calibration lock (except queries and :CODE). Calibration code or password (default: KI002010). Request the number of times the unit has been calibrated. Initiate calibration. Lock out calibration (opposite of enabling cal with :CODE command). Request comprehensive cal lock state. (0 = locked; 1 = unlocked) Save cal constants to EEROM. Send cal date to 2010. Request cal date from 2010. Send next due cal date to 2010. Request next due cal date from 2010.

**Table B-1 (cont.)**  
Remote calibration command summary

Command	Description
:CALibration	
:PROTected	
:DC	DC cal steps.
:STEP0	Rear terminal short step. <sup>1</sup>
:STEP1	Front terminal short circuit.
:STEP2	Open circuit.
:STEP3 <NRf>	10V DC step.
:STEP4 <NRf>	-10V DC step.
:STEP5 <NRf>	100V DC step.
:STEP6 <NRf>	10Ω 4-wire step.
:STEP7 <NRf>	1kΩ 4-wire step.
:STEP8 <NRf>	10kΩ 4-wire step.
:STEP9 <NRf>	100kΩ 4-wire step.
:STEP10 <NRf>	1MΩ 4-wire step.
:STEP11 <NRf>	10mA DC step.
:STEP12 <NRf>	100mA DC step.
:STEP13 <NRf>	1A DC step.
:AC	AC cal steps.
:STEP1	10mV AC at 1kHz step.
:STEP2	100mV AC at 1kHz step.
:STEP3	100mV AC at 50kHz step.
:STEP4	1V AC at 1 kHz step.
:STEP5	1V AC at 50kHz step.
:STEP6	10V AC at 1kHz step.
:STEP7	10V AC at 50kHz step.
:STEP8	100V AC at 1kHz step.
:STEP9	100V AC at 50kHz step.
:STEP10	700V AC at 1kHz step.
:STEP11	100mA AC at 1kHz step.
:STEP12	1A AC at 1kHz step.
:STEP13	2A AC at 1kHz step.
:STEP14	1V AC at 3Hz step. <sup>1</sup>
:STEP15	1V AC at 1kHz step. <sup>1</sup>

Notes:

<sup>1</sup> DC:STEP0, AC:STEP14, and AC:STEP15 are one-time factory calibration points and are valid only in manufacturing calibration mode.

<sup>2</sup> Upper-case letters indicate short form of each command. For example, instead of sending ":CALibration:PROTected:INITiate,", you can send":CAL:PROT:INIT:"



## Miscellaneous calibration commands

Miscellaneous commands perform miscellaneous calibration functions such as programming the calibration code and date. These commands are discussed in detail in the following paragraphs.

### **:CODE (:CALibration:PRO Tected:CODE)**

<b>Purpose</b>	To program the calibration code or password so that you can perform the calibration procedures.
<b>Format</b>	<code>:cal:prot:code '&lt;char_string&gt;'</code>
<b>Parameter</b>	Up to a 8-character string including letters and numbers.
<b>Description</b>	The :CODE command enables the Model 2010 calibration procedures when performing these procedures over the bus. In general, this command must be sent to the unit before sending any other comprehensive or manufacturing calibration command. The default calibration code is KI002010.
<b>Note</b>	<ul style="list-style-type: none"><li>• The :CODE command should be sent only once before performing either the comprehensive or factory calibration. Do not send :CODE before each calibration step.</li><li>• To change the code, first send the present code, and then send the new code.</li><li>• The code parameter must be enclosed in single quotes.</li></ul>
<b>Example</b>	<code>:CAL:PROT:CODE 'KI002010'</code> Send default code of KI002010

### **:COUNT? (:CALibration:PRO Tected:COUNT?)**

<b>Purpose</b>	To determine how many times the Model 2010 has been calibrated.
<b>Format</b>	<code>:cal:prot:coun?</code>
<b>Response</b>	<code>&lt;n&gt;</code> Calibration count.
<b>Description</b>	The :COUNT? command lets you determine how many times the Model 2010 has been calibrated.
<b>Note</b>	Use the :COUNT? command to help you monitor for unauthorized calibration procedures.
<b>Example</b>	<code>:CAL:PROT:COUN?</code> Request number of times the unit has been calibrated.

**:INIT (:CALibration:PRO Tected:INI Tiate)**

<b>Purpose</b>	To initiate comprehensive and factory calibration procedures.	
<b>Format</b>	:cal:prot:init	
<b>Description</b>	The :INIT command enables Model 2010 calibration when performing these procedures over the bus. This command must be sent to the unit after sending the :CODE command, but before sending any other DC, AC, or manufacturing calibration command.	
<b>Note</b>	The :INIT command should be sent only once before performing either DC, AC, or factory calibration. Do not send :INIT before each calibration step.	
<b>Example</b>	:CAL:PROT:INIT	Initiate calibration.

**:LOCK (:CALibration:PRO Tected:LOCK)**

<b>Purpose</b>	To lock out comprehensive or manufacturing calibration.	
<b>Format</b>	:cal:prot:lock	
<b>Description</b>	The :LOCK command lets you lock out both comprehensive and manufacturing calibration after completing those procedures. Thus, :LOCK performs the opposite of enabling calibration with the :CODE command.	
<b>Note</b>	To unlock comprehensive calibration, send the :CODE command. To unlock manufacturing calibration, hold in the OPEN key while turning on the power.	
<b>Example</b>	:CAL:PROT:LOCK	Lock out calibration.

**:LOCK? (:CALibration:PRO Tected:LOCK?)**

<b>Purpose</b>	To read comprehensive calibration lock status.	
<b>Format</b>	:cal:prot:lock?	
<b>Purpose</b>	0	Comprehensive calibration locked.
	1	Comprehensive calibration unlocked.
<b>Description</b>	The :LOCK? query requests status from the Model 2010 on calibration locked/unlocked state. Calibration must be enabled sending the :CODE command before calibration can be performed.	
<b>Example</b>	:CAL:PROT:LOCK?	Request cal lock state.

**:SAVE (:CALibration:PRO Tected:SAVE)**

<b>Purpose</b>	To save calibration constants in EEROM after the calibration procedure.	
<b>Format</b>	:cal:prot:save	
<b>Description</b>	The :SAVE command stores internally calculated calibration constants derived during both comprehensive and manufacturing calibration in EEROM. (EEROM is non-volatile memory.) Calibration constants will be retained indefinitely once saved. Generally, :SAVE is sent after all other calibration steps (except for :LOCK).	
<b>Note</b>	Calibration will be temporary unless the :SAVE command is sent to permanently store calibration constants.	
<b>Example</b>	:CAL:PROT:SAVE	Save calibration constants.

**:DATE (:CALibration:PRO Tected:DATE)**

<b>Purpose</b>	To send the calibration date to the instrument.	
<b>Format</b>	:cal:prot:date <year>, <month>, <day>	
<b>Parameters</b>	<year> = 1995 to 2094 <month> = 1 to 12 <day> = 1 to 31	
<b>Query format</b>	:cal:prot:date?	
<b>Response</b>	<year>, <month>, <day>	
<b>Description</b>	The :DATE command allows you to store the calibration date in instrument memory for future reference. You can read back the date from the instrument over the bus by using the :DATE? query or the CALIBRATION selection in the front panel CAL menu.	
<b>Note</b>	The year, month, and day parameters must be delimited by commas.	
<b>Examples</b>	:CAL:PROT:DATE 1995,12,16	Send cal date (12/16/95).
	:CAL:PROT:DATE?	Request cal date.

**:NDUE (:CALibration:PRO Tected:NDUE)**

<b>Purpose</b>	To send the next calibration due date to the instrument.	
<b>Format</b>	:cal:prot:ndue <year>, <month>, <day>	
<b>Parameters</b>	<year> = 1995 to 2094 <month> = 1 to 12 <day> = 1 to 31	
<b>Query format</b>	:cal:prot:ndue?	
<b>Response</b>	<year>, <month>, <day>	
<b>Description</b>	The :NDUE command allows you to store the date when calibration is next due in instrument memory. You can read back the next due date from the instrument over the bus by using the :NDUE? query or the front panel CAL menu.	
<b>Note</b>	The next due date parameters must be delimited by commas.	
<b>Examples</b>	:CAL:PROT:NDUE 1996,12,16	Send due date (12/16/96).
	:CAL:PROT:NDUE?	Request due date.

## DC calibration commands

The :DC commands perform calibration of the DCV, DCI, and ohms functions. Table B-2 summarizes these calibration commands along with parameter limits.

**Table B-2**  
DC calibration commands

Command	Description	Parameter limits
:CALibration		
:PROTeCted		
:DC		
:STEP1	Front terminal short circuit.	
:STEP2	Open circuit.	
:STEP3 <NRf>	10V DC calibration step.	9 to 11
:STEP4 <NRf>	-10V DC calibration step.	-9 to -11
:STEP5 <NRf>	100V DC calibration step.	90 to 110
:STEP6 <NRf>	10 $\Omega$ 4-wire calibration step.	9 to 11
:STEP7 <NRf>	1k $\Omega$ 4-wire calibration step.	900 to 1.1E3
:STEP8 <NRf>	10k $\Omega$ 4-wire calibration step.	9E3 to 11E3
:STEP9 <NRf>	100k $\Omega$ 4-wire calibration step.	90E3 to 110E3
:STEP10 <NRf>	1M $\Omega$ 4-wire calibration step.	900E3 to 1.1E6
:STEP11 <NRf>	10mA DC calibration step.	9E-3 to 11E-3
:STEP12 <NRf>	100mA DC calibration step.	90E-3 to 110E-3
:STEP13 <NRf>	1A DC calibration step.	0.9 to 1.1

**:STEP1 (:CALibration:PROTected:DC:STEP1)**

<b>Purpose</b>	To perform front terminal short-circuit calibration.	
<b>Format</b>	:cal:prot:dc:step1	
<b>Description</b>	:STEP1 performs the short-circuit calibration step in the comprehensive calibration procedure. Connect a low-thermal short (Model 8610) to the front panel input jacks before sending this command.	
<b>Example</b>	:CAL:PROT:DC:STEP1	Perform short-circuit calibration.

**:STEP2 (:CALibration:PROTected:DC:STEP2)**

<b>Purpose</b>	To perform front terminal open-circuit calibration.	
<b>Format</b>	:cal:prot:dc:step2	
<b>Description</b>	:STEP2 performs the open-circuit calibration step in the comprehensive calibration procedure. Disconnect all cables and accessories from the input jacks before sending this command.	
<b>Example</b>	:CAL:PROT:DC:STEP2	Perform open circuit calibration.

**:STEP3 (:CALibration:PROTected:DC:STEP3)**

<b>Program</b>	To program the +10V comprehensive calibration step.	
<b>Format</b>	:cal:prot:dc:step3 <Cal_voltage>	
<b>Parameter</b>	<Cal_voltage> = 9 to 11 [V]	
<b>Description</b>	:STEP3 programs the +10V DC comprehensive calibration step. The allowable range of the calibration voltage parameter is from 9 to 11, but 10 is recommended for best results.	
<b>Example</b>	:CAL:PROT:DC:STEP3 10	Program 10V step.

**:STEP4 (:CALibration:PROTected:DC:STEP4)**

<b>Purpose</b>	To program the -10V DC comprehensive calibration step.
<b>Format</b>	:cal:prot:dc:step4 <Cal_voltage>
<b>Parameter</b>	<Cal_voltage> = -9 to -11 [V]
<b>Description</b>	:STEP4 programs the -10V DC comprehensive calibration step. The allowable range of the calibration voltage parameter is from -9 to -11, but -10 is recommended for best results.
<b>Example</b>	:CAL:PROT:DC:STEP4 -10      Program -10V step.

**:STEP5 (:CALibration:PROTected:DC:STEP5)**

<b>Purpose</b>	To program the 100V DC comprehensive calibration step.
<b>Format</b>	:cal:prot:dc:step5 <Cal_voltage>
<b>Parameter</b>	<Cal_voltage> = 90 to 110 [V]
<b>Description</b>	:STEP5 programs the 100V DC comprehensive calibration step. The allowable range of the calibration voltage parameter is from 90 to 110, but 100 is recommended for best results.
<b>Example</b>	:CAL:PROT:DC:STEP5 100      Program 100V step.

**:STEP6 (:CALibration:PROTected:DC:STEP6)**

<b>Purpose</b>	To program the 10 $\Omega$ 4-wire comprehensive calibration step.
<b>Format</b>	:cal:prot:dc:step6 <Cal_resistance>
<b>Parameter</b>	<Cal_resistance> = 9 to 11 [ $\Omega$ ]
<b>Description</b>	:STEP6 programs the 10 $\Omega$ 4-wire resistance comprehensive calibration step. The allowable range of the calibration resistance parameter is from 9 to 11, but 10 is recommended for best results.
<b>Example</b>	:CAL:PROT:DC:STEP6 10      Program 10 $\Omega$ step.

**:STEP7 (:CALibration:PROTected:DC:STEP7)**

<b>Purpose</b>	To program the 1k $\Omega$ 4-wire comprehensive calibration step.
<b>Format</b>	:cal:prot:dc:step7 <Cal_resistance>
<b>Parameter</b>	<Cal_resistance> = 900 to 1.1E3 [ $\Omega$ ]
<b>Description</b>	:STEP7 programs the 1k $\Omega$ 4-wire resistance comprehensive calibration step. The allowable range of the calibration resistance parameter is from 900 to 1.1E3, but 1E3 is recommended for best results.
<b>Example</b>	:CAL:PROT:DC:STEP7 1E3    Program 1k $\Omega$ step.

**:STEP8 (:CALibration:PROTected:DC:STEP8)**

<b>Purpose</b>	To program the 10k $\Omega$ 4-wire comprehensive calibration step.
<b>Format</b>	:cal:prot:dc:step8 <Cal_resistance>
<b>Parameter</b>	<Cal_resistance> = 9E3 to 11E3 [ $\Omega$ ]
<b>Description</b>	:STEP8 programs the 10k $\Omega$ 4-wire resistance comprehensive calibration step. The allowable range of the calibration resistance parameter is from 9E3 to 11E3, but 10E3 is recommended for best results.
<b>Example</b>	:CAL:PROT:DC:STEP8 10E3    Program 10k $\Omega$ step.

**:STEP9 (:CALibration:PROTected:DC:STEP9)**

<b>Purpose</b>	To program the 100k $\Omega$ 4-wire comprehensive calibration step.
<b>Format</b>	:cal:prot:dc:step9 <Cal_resistance>
<b>Parameter</b>	<Cal_resistance> = 90E3 to 110E3 [ $\Omega$ ]
<b>Description</b>	:STEP9 programs the 100k $\Omega$ 4-wire resistance comprehensive calibration step. The allowable range of the calibration resistance parameter is from 90E3 to 110E3, but 100E3 is recommended for best results.
<b>Example</b>	:CAL:PROT:DC:STEP9 100E3    Program 100k $\Omega$ step.



**:STEP10 (CALibration:PRO Tected:DC:STEP10)**

<b>Purpose</b>	To program the 1M $\Omega$ comprehensive calibration step.
<b>Format</b>	:cal:prot:dc:step10 <Cal_resistance>
<b>Parameter</b>	<Cal_resistance> = 900E3 to 1.1E6 [ $\Omega$ ]
<b>Description</b>	:STEP10 programs the 1M $\Omega$ comprehensive calibration step. The allowable range of the calibration resistance parameter is from 900E3 to 1.1E6. Use the 1E6 value whenever possible, or the closest possible value.
<b>Example</b>	:CAL:PROT:DC:STEP10            Program 1M $\Omega$ calibration step.

**:STEP11 (CALibration:PRO Tected:DC:STEP11)**

<b>Purpose</b>	To program the 10mA comprehensive calibration step.
<b>Format</b>	:cal:prot:dc:step11 <Cal_current>
<b>Parameter</b>	<Cal_current> = 9E-3 to 11E-3 [A]
<b>Description</b>	:STEP11 programs the 10mA comprehensive calibration step. The allowable range of the calibration current parameter is from 9E-3 to 11E-3. Use the 10E-3 value whenever possible for best results.
<b>Example</b>	:CAL:PROT:DC:STEP11 10E-3        Program 10mA step.

**:STEP12 (CALibration:PRO Tected:DC:STEP12)**

<b>Purpose</b>	To program the 100mA comprehensive calibration step.
<b>Format</b>	:cal:prot:dc:step12 <Cal_current>
<b>Parameter</b>	<Cal_current> = 90E-3 to 110E-3 [A]
<b>Description</b>	:STEP12 programs the 100mA comprehensive calibration step. The allowable range of the calibration current parameter is from 90E-3 to 110E-3. Use the 100E-3 value whenever possible for best results.
<b>Example</b>	:CAL:PROT:DC:STEP12 0.1    Program 100mA step.

**:STEP13 (CALibration:PRO Tected:DC:STEP13)**

<b>Purpose</b>	To program the 1A comprehensive calibration step.
<b>Format</b>	:cal:prot:dc:step13 <Cal_current>
<b>Parameter</b>	<Cal_current> = 0.9 to 1.1 [A]
<b>Description</b>	:STEP13 programs the 1A comprehensive calibration step. The allowable range of the calibration current parameter is from 0.9 to 1.1. Use a value of 1 whenever possible for best results.
<b>Example</b>	:CAL:PROT:DC:STEP13 1    Program 1A step.

## AC calibration commands

The :AC commands perform comprehensive (user) calibration of the ACV and ACI functions. Table B-3 summarizes these calibration commands.

**Table B-3**  
*AC calibration commands*

Command	Description
:CALibration	
:PROTeCted	
:AC	
:STEP	
1	10mV AC at 1kHz calibration step.
2	100mV AC at 1kHz calibration step.
3	100mV AC at 50kHz calibration step.
4	1V AC at 1 kHz calibration step.
5	1V AC at 50kHz calibration step.
6	10V AC at 1kHz calibration step.
7	10V AC at 50kHz calibration step.
8	100V AC at 1kHz calibration step.
9	100V AC at 50kHz calibration step.
10	700V AC at 1kHz calibration step.
11	100mA AC at 1kHz calibration step.
12	1A AC at 1kHz calibration step.
13	2A AC at 1kHz calibration step.

**:AC:STEP<n> (CALibration:PRO Tected:AC:STEP<n>)**

<b>Purpose</b>	To program individual AC calibration steps.	
<b>Format</b>	:cal:prot:ac:step<n>	
<b>Parameters</b>	1	10mV AC at 1kHz calibration step.
	2	100mV AC at 1kHz calibration step.
	3	100mV AC at 50kHz calibration step.
	4	1V AC at 1kHz calibration step.
	5	1V AC at 50kHz calibration step.
	6	10V AC at 1kHz calibration step.
	7	10V AC at 50kHz calibration step.
	8	100V AC at 1kHz calibration step.
	9	100V AC at 50kHz calibration step.
	10	700V AC at 1kHz calibration step.
	11	100mA AC at 1kHz calibration step.
	12	1A AC at 1kHz calibration step.
	13	2A AC at 1kHz calibration step.
<b>Description</b>	The :AC:STEP command programs the 13 individual AC calibration steps; <n> represents the calibration step number. The appropriate signal must be connected to the instrument when programming each step, as summarized in the parameters listed above.	
<b>Example</b>	:CAL:PROT:AC:STEP7	Program AC step 7.

## Manufacturing calibration commands

The following three calibration steps are only performed at the factory or when the unit has been repaired:

:CALibration:PROTeCted:AC:STEP14	1V AC at 3Hz
:CALibration:PROTeCted:AC:STEP15	1V AC at 1kHz
:CALibration:PROTeCted:DC:STEP0	Rear terminal short circuit

### **:AC:STEP<14| 15> (CALibration:PROTeCted:AC:STEP<14| 15>)**

<b>Purpose</b>	To program individual AC manufacturing calibration steps.
<b>Format</b>	:cal:prot:ac:step14 <Cal_voltage> :cal:prot:ac:step15 <Cal_frequency>
<b>Parameter</b>	<Cal_voltage> = 1 [1V nominal] <Cal_frequency> = 1E3 [1kHz nominal]
<b>Description</b>	The :AC:STEP14 and :AC:STEP:15 commands program the two manufacturing AC calibration steps. The appropriate signal must be connected to the instrument when programming each step, as summarized by the parameters listed above.
<b>Examples</b>	:CAL:PROT:AC:STEP14 1      Program AC step 14. :CAL:PROT:AC:STEP15 1E3    Program AC step 15.

**:DC:STEP0 (:CALibration:PROTected:DC:STEP0)**

<b>Purpose</b>	To perform rear terminal short-circuit calibration.	
<b>Format</b>	:cal:prot:dc:step0	
<b>Description</b>	:STEP0 performs the rear short-circuit calibration step in the manufacturing calibration procedure. Connect a low-thermal short (Model 8610) to the rear panel input jacks, and select the rear inputs before sending this command.	
<b>Example</b>	:CAL:PROT:DC:STEP0	Perform rear short-circuit calibration.

## Remote error reporting

Methods to detect and determine the nature of calibration errors are discussed in the following paragraphs.

### Error summary

Table B-4 summarizes Model 2010 calibration errors.

**Table B-4**  
*Calibration error summary*

Error number	Description
+400	"10 vdc zero error"
+401	"100 vdc zero error"
+402	"10 vdc full scale error"
+403	"-10 vdc full scale error"
+404	"100 vdc full scale error"
+405	"-100 vdc full scale error"
+406	"1k 2-w zero error"
+407	"10k 2-w zero error"
+408	"100k 2-w zero error"
+409	"10M 2-w zero error "
+410	"10M 2-w full scale error"
+411	"10M 2-w open error"
+412	"1k 4-w zero error"
+413	"10k 4-w zero error"
+414	"100k 4-w zero error"
+415	"10M 4-w sense lo zero error",
+416	"1k 4-w full scale error",
+417	"10k 4-w full scale error",
+418	"100k 4-w full scale error",
+419	"1M 4-w full scale error",
+420	"10M 4-w full scale error"
+421	"10m adc zero error"
+422	"100m adc zero error"
+423	"10m adc full scale error"
+424	"100m adc full scale error"
+425	"1 adc full scale error"
+438	"Date of calibration not set"
+439	"Next date of calibration not set"
+440	"Gain-aperture correction error"
+450	"100m vac dac error"
+451	"1 vac dac error"
+452	"10 vac dac error"
+453	"100 vac dac error"

**Table B-4 (cont.)**  
*Calibration error summary*

<b>Error number</b>	<b>Description</b>
+454	"100m vac zero error"
+455	"100m vac full scale error"
+456	"1 vac zero error"
+457	"1 vac full scale error"
+458	"1 vac noise error"
+459	"10 vac zero error"
+460	"10 vac full scale error"
+461	"10 vac noise error"
+462	"100 vac zero error"
+463	"100 vac full scale error"
+464	"750 vac zero error"
+465	"750 vac full scale error"
+466	"750 vac noise error"
+467	"Post filter offset error"
+468	"1 aac zero error"
+469	"1 aac full scale error"
+470	"3 aac zero error"
+471	"3 aac full scale error"
+472	"Input time constant error"
+473	"Frequency gain error"
+474	"10 vdc sense zero error"
+475	"10 2-w zero error"
+476	"10 4-w zero error"
+477	"10 4-w full scale error"
+478	"1 adc zero error"
+479	"10 Ohm DryCkt Zero error"
+480	"10 Ohm DryCkt FS error"
+481	"100 Ohm DryCkt Zero error"
+482	"100 Ohm DryCkt FS error"
+483	"10 Ohm Ioff Ocomp FS error"
+484	"10 Ohm 4-w Ioff Ocomp DryCkt FS error"
+485	"1K Ohm Ioff Ocomp FS error"
+486	"100 Ohm 4-w Ioff Ocomp DryCkt FS error"
+487	"10K Ohm Ioff Ocomp FS error"
+490	"Front-rear switch incorrect"
+500	"Calibration data invalid"
+513	"AC calibration data lost"
+514	"DC calibration data lost"
+515	"Calibration dates lost"
+610	"Questionable Calibration"

Note: These errors set bit 3 in the Standard Event Status Register.



## Error queue

As with other Model 2010 errors, any calibration error will be reported in the bus error queue. You can read this queue by using the `:SYST:ERR?` query. The Model 2010 will respond with the appropriate error message, as summarized in Table B-4.

## Statusbyte EAV (Error Available) bit

Whenever an error is available in the error queue, the EAV (Error Available) bit (bit 2) of the status byte will be set. Use the `*STB?` query or serial polling to obtain the status byte, and then test bit 2 to see if it is set. If the EAV bit is set, an error has occurred, and you can use the `:SYST:ERR?` query to read the error and at the same time clear the EAV bit in the status byte.

## Generating an SRQ on error

To program the instrument to generate an IEEE-488 bus SRQ when an error occurs, send the `*SRE 4` command. This command will enable SRQ when the EAV bit is set. You can then read the status byte and error queue as outlined above to check for errors and to determine the exact nature of the error.

## Detecting calibration step completion

When sending remote calibration commands, you must wait until the instrument completes the current operation before sending a command. You can use either `*OPC?` or `*OPC` to help determine when each calibration step is completed.

### Using the `*OPC?` query

With the `*OPC?` (operation complete) query, the instrument will place an ASCII 1 in the output queue when it has completed each step. To determine when the OPC response is ready, perform the following:

1. Repeatedly test the MAV (Message Available) bit (bit 4) in the status byte and wait until it is set. (You can request the status byte by using the `*STB?` query or by serial polling.)
2. When MAV is set, a message is available in the output queue, and you can read the output queue and test for an ASCII 1.
3. After reading the output queue, repeatedly test MAV again until it clears. At this point, the calibration step is completed.

### Using the `*OPC` command

The `*OPC` (operation complete) command can also be used to detect the completion of each calibration step. To use `*OPC` to detect the end of each calibration step, you must do the following:

1. Enable operation complete by sending `*ESE 1`. This command sets the OPC (operation complete bit) in the standard event enable register, allowing operation complete status from the standard event status register to set the ESB (event summary bit) in the status byte when operation complete is detected.
2. Send the `*OPC` command immediately following each calibration command. For example:

```
:CAL:PROT:DC:STEP1;*OPC
```

Note that you must include the semicolon (;) to separate the two commands and that the `*OPC` command must appear on the same line as the calibration command.

3. After sending a calibration command, repeatedly test the ESB (Event Summary) bit (bit 5) in the status byte until it is set. (Use either the `*STB?` query or serial polling to request the status byte.)
4. Once operation complete has been detected, clear OPC status using one of two methods: (1) Use the `*ESR?` query, and then read the response to clear the standard event status register, or (2) Send the `*CLS` command to clear the status registers.

Note that sending `*CLS` will also clear the error queue and operation complete status.

## **Generating an SRQ on calibration complete**

An IEEE-488 bus SRQ (service request) can be used to detect operation complete instead of repeatedly polling the Model 2010. To use this method, send both \*ESE 1 and \*SRE 32 to the instrument, then include the \*OPC command at the end of each calibration command line, as covered above. Refer to your controller's documentation for information on detecting and servicing SRQs.

---

# C Calibration Program

## Introduction

This appendix includes a calibration program written in BASIC to help you in calibrate the Model 2010. Refer to Section 2 for more details on calibration procedures, equipment, and connections.

## Computer hardware requirements

The following computer hardware is required to run the calibration program:

- IBM PC, AT, or compatible computer.
- Keithley KPC-488.2, KPS-488.2, or KPC-488.2AT, or CEC PC-488 IEEE-488 interface for the computer.
- Two shielded IEEE-488 connecting cables (Keithley Model 7007)

## Software requirements

In order to use the calibration program, you will need the following software:

- Microsoft QBasic (supplied with MS-DOS 5.0 or later).
- MS-DOS version 5.0 or later.
- HP-style Universal Language Driver, CECHP.EXE (supplied with Keithley and CEC interface cards listed above).

## Calibration equipment

The following calibration equipment is required:

- Fluke 5700A Calibrator
- Keithley Model 8610 Calibration Short

See Section 2 for detailed equipment information.

## General program instructions

1. With the power off, connect the Model 2010 and the calibrator to the IEEE-488 interface of the computer. Be sure to use shielded IEEE-488 cables for bus connections.
2. Turn on the computer, the Model 2010, and the calibrator. Allow the Model 2010 and the calibrator to warm up for at least two hours before performing calibration.
3. Make sure the Model 2010 is set for a primary address of 16. (Use the front panel GPIB key to check or change the address.)
4. Make sure the calibrator primary address is at its factory default setting of 4.
5. Make sure that the computer bus driver software (CECHP.EXE) is properly initialized.
6. Enter the QBasic editor, and type in the appropriate program below. Check thoroughly for errors, then save it using a convenient filename.

**NOTE** *The program assumes a default calibration code of K1002010. If the calibration code has been changed, modify the :CAL:PROT:CODE parameter accordingly.*

7. Run the program, and follow the prompts on the screen to perform calibration.

**Program C-1. Q Basic calibration program**

```
' Model 2010 calibration program for use with the Fluke 5700A calibrator.
' Rev. 1.0, 9/11/95
OPEN "IEEE" FOR OUTPUT AS #1           ' Open IEEE-488 output path.
OPEN "IEEE" FOR INPUT AS #2           ' Open IEEE-488 input path.
PRINT #1, "INTERM CRLF"                ' Set input terminator.
PRINT #1, "OUTTERM LF"                 ' Set output terminator.
PRINT #1, "REMOTE 4 16"                ' Put 2010, 5700A in remote.
PRINT #1, "CLEAR"                      ' Send DCL.
PRINT #1, "OUTPUT 16;:SYST:PRES;*CLS"  ' Initialize 2010.
PRINT #1, "OUTPUT 16;*ESE 1;*SRE 32"  ' Enable OPC and SRQ
PRINT #1, "OUTPUT 4;*RST;*CLS;STBY"   ' Reset 5700A calibrator.
PRINT #1, "OUTPUT 4;CUR_POST NORMAL"  ' Normal current output.
C$ = ":CAL:PROT:"                      ' 2010 partial command header.
'
CLS                                     ' Clear CRT.
PRINT "Model 2010 Multimeter Comprehensive Calibration Program"
PRINT #1, "OUTPUT 16;:CAL:PROT:CODE 'KI002010'" ' Send KI002010 cal code.
PRINT #1, "OUTPUT 16;:CAL:PROT:INIT"    ' Initiate calibration.
GOSUB ErrCheck
RESTORE CmdList
'
FOR I = 1 TO 26                         ' Loop for all cal points.
READ Msg$, Cmd$                         ' Read message, cal strings.
SELECT CASE I                           ' Select cal sequence.
    CASE 1, 2
        PRINT Msg$
        GOSUB KeyCheck
    CASE 3
        PRINT "Connect calibrator to INPUT and SENSE jacks."
        PRINT "Wait 3 minutes."
        GOSUB KeyCheck
        PRINT #1, "OUTPUT 4;EXTSENSE OFF"
        PRINT #1, "OUTPUT 4;"; Msg$
        PRINT #1, "OUTPUT 4;OPER"
    CASE 4, 5, 12, 13, 15 TO 23, 25, 26
        PRINT #1, "OUTPUT 4;"; Msg$
        PRINT #1, "OUTPUT 4;OPER"
    CASE 6 TO 10
        PRINT #1, "OUTPUT 4;"; Msg$
        PRINT #1, "OUTPUT 4;EXTSENSE ON"
        PRINT #1, "OUTPUT 4;OPER"
        PRINT #1, "OUTPUT 4;OUT?"
        PRINT #1, "ENTER 4"
        INPUT #2, R, R$, S
        Cmd$ = Cmd$ + " " + STR$(R)
    CASE 11, 14, 24
        J$ = "AMPS"
```

```

        IF I = 14 THEN J$ = "INPUT HI"
        PRINT #1, "OUTPUT 4;STBY"
        PRINT "Connect calibrator to "; J$; " and INPUT LO jacks."
        GOSUB KeyCheck
        PRINT #1, "OUTPUT 4;"; Msg$
        PRINT #1, "OUTPUT 4;OPER"

END SELECT
IF I > 2 THEN GOSUB Settle
PRINT #1, "OUTPUT 16;"; C$; Cmd$; ";*OPC"           ' Send cal command to 2010.
GOSUB CalEnd                                       ' Wait until cal step ends.
GOSUB ErrCheck                                     ' Check for cal error.
NEXT I
'
PRINT #1, "OUTPUT 4;STBY"
LINE INPUT "Enter calibration date (yyyy,mm,dd): "; D$
PRINT #1, "OUTPUT 16;:CAL:PROT:DATE "; D$
GOSUB ErrCheck
LINE INPUT "Enter calibration due date (yyyy,mm,dd): "; D$
PRINT #1, "OUTPUT 16;:CAL:PROT:NDUE "; D$
GOSUB ErrCheck
PRINT #1, "OUTPUT 16;:CAL:PROT:SAVE"           ' Save calibration constants.
GOSUB ErrCheck
PRINT #1, "OUTPUT 16;:CAL:PROT:LOCK"           ' Lock out calibration.
PRINT "Calibration completed."
PRINT #1, "OUTPUT 16;:SYST:PRES"
END
'
KeyCheck:                                         ' Check for key press routine.
WHILE INKEY$ <> "": WEND                          ' Flush keyboard buffer.
PRINT : PRINT "Press any key to continue (ESC to abort program)."
```

```

DO: I$ = INKEY$: LOOP WHILE I$ = ""
IF I$ = CHR$(27) THEN GOTO EndProg               ' Abort if ESC is pressed.
RETURN
'
CalEnd:                                           ' Check for cal step completion.
PRINT "Performing calibration step #"; I
DO: PRINT #1, "SRQ?"                             ' Request SRQ status.
INPUT #2, S                                       ' Input SRQ status byte.
LOOP UNTIL S                                       ' Wait for operation complete.
PRINT #1, "OUTPUT 16;*ESR?"                       ' Clear OPC.
PRINT #1, "ENTER 16"
INPUT #2, S
PRINT #1, "SPOLL 16"                             ' Clear SRQ.
INPUT #2, S
RETURN
'
ErrCheck:                                         ' Error check routine.
PRINT #1, "OUTPUT 16;:SYST:ERR?"                 ' Query error queue.
PRINT #1, "ENTER 16"
```



```

INPUT #2, E, Err$
IF E <> 0 THEN BEEP: PRINT Err$: GOTO ErrCheck' Display error.
RETURN
'
Settle:                                ' Calibrator settling routine.
DO: PRINT #1, "OUTPUT 4;ISR?"           ' Query status register.
PRINT #1, "ENTER 4"
INPUT #2, S
LOOP UNTIL (S AND &H1000)                ' Test settle bit.
RETURN
'
EndProg:                                ' Close files, end program.
BEEP: PRINT "Calibration aborted."
PRINT #1, "OUTPUT 4;STBY"
PRINT #1, "OUTPUT 16;:SYST:PRES"
PRINT #1, "LOCAL 4 16"
CLOSE
END
'
CmdList:
DATA "Connect low-thermal short to inputs, wait 3 minutes.,""DC:STEP1"
DATA "Disconnect low-thermal short from inputs.,""DC:STEP2"
DATA "OUT 10 V,0 HZ","DC:STEP3 10"
DATA "OUT -10 V","DC:STEP4 -10"
DATA "OUT 100 V","DC:STEP5 100"
DATA "OUT 10 OHM","DC:STEP6"
DATA "OUT 1 KOHM","DC:STEP7"
DATA "OUT 10 KOHM","DC:STEP8"
DATA "OUT 100 KOHM","DC:STEP9"
DATA "OUT 1 MOHM","DC:STEP10"
DATA "OUT 10 MA","DC:STEP11 10E-3"
DATA "OUT 100 MA","DC:STEP12 100E-3"
DATA "OUT 1A","DC:STEP13 1"
DATA "OUT 10 MV,1 KHZ","AC:STEP1"
DATA "OUT 100 MV,1 KHZ","AC:STEP2"
DATA "OUT 100 MV,50 KHZ","AC:STEP3"
DATA "OUT 1 V,1 KHZ","AC:STEP4"
DATA "OUT 1 V,50 KHZ","AC:STEP5"
DATA "OUT 10 V,1 KHZ","AC:STEP6"
DATA "OUT 10 V,50 KHZ","AC:STEP7"
DATA "OUT 100 V,1 KHZ","AC:STEP8"
DATA "OUT 100 V,50 KHZ","AC:STEP9"
DATA "OUT 700 V,1 KHZ","AC:STEP10"
DATA "OUT 100 MA,1 KHZ","AC:STEP11"
DATA "OUT 1 A,1 KHZ","AC:STEP12"
DATA "OUT 2 A,1 KHZ","AC:STEP13"

```

---

# Index

## A

- AC calibration commands B-14
- Accuracy calculations A-7
- Analog signal switching states 4-13
- Assembly drawings 5-4

## C

- Calibration 2-1
- Calibration command reference B-1
- Calibration considerations 2-4
- Calibration code 2-5
- Calibration equipment C-3
- Calibration program C-1
- Case cover removal 5-5
- Changing trigger link lines 5-6
- Command summary B-2
- Component layouts 6-3
- Comprehensive calibration 2-6
- Computer hardware requirements C-2

## D

- DC calibration commands B-8
- Detecting calibration step completion B-21
- Disassembly 5-1

## E

- Environmental conditions 2-3

## F

- Factory service 6-3
- Front panel calibration 2-8
- Front panel disassembly 5-8
- Front panel tests 4-3

## G

- General program instructions C-3

## H

- Handling and cleaning 5-2

## I

- Instrument re-assembly 5-12

## M

- Main CPU firmware replacement 5-9
- Manufacturing calibration 2-24
- Miscellaneous calibration commands B-4, B-16
- Motherboard removal 5-7

## N

- No comm link error 4-18

## O

- Ordering information 6-2

## P

- Parts lists 6-2
- Performance verification 1-1
- Performing the verification test procedure 1-6
- Power-on self-test 4-2
- Principles of operation 4-4

## R

- Remote calibration 2-16
- Remote error reporting B-18
- Removing power components 5-10
- Repair considerations 4-2
- Replaceable parts 6-1
- Replacing the AMPS fuse 3-4
- Routine maintenance 3-1

## S

- Setting the line voltage and replacing the line fuse 3-2
- Software requirements C-2
- Specifications A-1
- Static sensitive devices 5-3

## T

- Troubleshooting 4-1, 4-10

## V

- Verification test requirements 1-3
- Verifying AC current 1-11
- Verifying AC voltage 1-8
- Verifying DC current 1-10
- Verifying DC voltage 1-7
- Verifying frequency 1-17
- Verifying ratio 1-18
- Verifying resistance 1-12
- Verifying temperature 1-14

**KEITHLEY**

**Keithley Instruments, Inc.**

28775 Aurora Road  
Cleveland, Ohio 44139

Printed in the U.S.A.