

Model 2002 Multimeter

User's Manual

2002-900-01 Rev. E / February 2009

KEITHLEY

A GREATER MEASURE OF CONFIDENCE

WARRANTY

Keithley Instruments, Inc. warrants this product to be free from defects in material and workmanship for a period of one (1) year from date of shipment.

Keithley Instruments, Inc. warrants the following items for 90 days from the date of shipment: probes, cables, software, rechargeable batteries, diskettes, and documentation.

During the warranty period, Keithley Instruments will, at its option, either repair or replace any product that proves to be defective.

To exercise this warranty, write or call your local Keithley Instruments representative, or contact Keithley Instruments headquarters in Cleveland, Ohio. You will be given prompt assistance and return instructions. Send the product, transportation prepaid, to the indicated service facility. Repairs will be made and the product returned, transportation prepaid. Repaired or replaced products are warranted for the balance of the original warranty period, or at least 90 days.

LIMITATION OF WARRANTY

This warranty does not apply to defects resulting from product modification without Keithley Instruments' express written consent, or misuse of any product or part. This warranty also does not apply to fuses, software, non-rechargeable batteries, damage from battery leakage, or problems arising from normal wear or failure to follow instructions.

THIS WARRANTY IS IN LIEU OF ALL OTHER WARRANTIES, EXPRESSED OR IMPLIED, INCLUDING ANY IMPLIED WARRANTY OF MERCHANTABILITY OR FITNESS FOR A PARTICULAR USE. THE REMEDIES PROVIDED HEREIN ARE BUYER'S SOLE AND EXCLUSIVE REMEDIES.

NEITHER KEITHLEY INSTRUMENTS, INC. NOR ANY OF ITS EMPLOYEES SHALL BE LIABLE FOR ANY DIRECT, INDIRECT, SPECIAL, INCIDENTAL, OR CONSEQUENTIAL DAMAGES ARISING OUT OF THE USE OF ITS INSTRUMENTS AND SOFTWARE, EVEN IF KEITHLEY INSTRUMENTS, INC. HAS BEEN ADVISED IN ADVANCE OF THE POSSIBILITY OF SUCH DAMAGES. SUCH EXCLUDED DAMAGES SHALL INCLUDE, BUT ARE NOT LIMITED TO: COST OF REMOVAL AND INSTALLATION, LOSSES SUSTAINED AS THE RESULT OF INJURY TO ANY PERSON, OR DAMAGE TO PROPERTY.

KEITHLEY

A G R E A T E R M E A S U R E O F C O N F I D E N C E

Keithley Instruments, Inc.

Corporate Headquarters • 28775 Aurora Road • Cleveland, Ohio 44139
440-248-0400 • Fax: 440-248-6168 • 1-888-KEITHLEY (1-888-534-8453) • www.keithley.com

www.valuetronics.com

Model 2002 Multimeter User's Manual

©2009, Keithley Instruments, Inc.
Cleveland, Ohio, U.S.A.
All rights reserved.

Any unauthorized reproduction, photocopy, or use of the information herein, in whole or in part, without the prior written approval of Keithley Instruments, Inc. is strictly prohibited.

TSP™, TSP-Link™, and TSP-Net™ are trademarks of Keithley Instruments, Inc. All Keithley Instruments product names are trademarks or registered trademarks of Keithley Instruments, Inc. Other brand names are trademarks or registered trademarks of their respective holders.

Document Number: 2002-900-01 Rev. E/ February 2009

The following safety precautions should be observed before using this product and any associated instrumentation. Although some instruments and accessories would normally be used with non-hazardous voltages, there are situations where hazardous conditions may be present.

This product is intended for use by qualified personnel who recognize shock hazards and are familiar with the safety precautions required to avoid possible injury. Read and follow all installation, operation, and maintenance information carefully before using the product. Refer to the user documentation for complete product specifications.

If the product is used in a manner not specified, the protection provided by the product warranty may be impaired.

The types of product users are:

Responsible body is the individual or group responsible for the use and maintenance of equipment, for ensuring that the equipment is operated within its specifications and operating limits, and for ensuring that operators are adequately trained.

Operators use the product for its intended function. They must be trained in electrical safety procedures and proper use of the instrument. They must be protected from electric shock and contact with hazardous live circuits.

Maintenance personnel perform routine procedures on the product to keep it operating properly, for example, setting the line voltage or replacing consumable materials. Maintenance procedures are described in the user documentation. The procedures explicitly state if the operator may perform them. Otherwise, they should be performed only by service personnel.

Service personnel are trained to work on live circuits, perform safe installations, and repair products. Only properly trained service personnel may perform installation and service procedures.

Keithley Instruments products are designed for use with electrical signals that are rated Measurement Category I and Measurement Category II, as described in the International Electrotechnical Commission (IEC) Standard IEC 60664. Most measurement, control, and data I/O signals are Measurement Category I and must not be directly connected to mains voltage or to voltage sources with high transient over-voltages. Measurement Category II connections require protection for high transient over-voltages often associated with local AC mains connections. Assume all measurement, control, and data I/O connections are for connection to Category I sources unless otherwise marked or described in the user documentation.

Exercise extreme caution when a shock hazard is present. Lethal voltage may be present on cable connector jacks or test fixtures. The American National Standards Institute (ANSI) states that a shock hazard exists when voltage levels greater than 30V RMS, 42.4V peak, or 60VDC are present. A good safety practice is to expect that hazardous voltage is present in any unknown circuit before measuring.

Operators of this product must be protected from electric shock at all times. The responsible body must ensure that operators are prevented access and/or insulated from every connection point. In some cases, connections must be exposed to potential human contact. Product operators in these circumstances must be trained to protect themselves from the risk of electric shock. If the circuit is capable of operating at or above 1000V, no conductive part of the circuit may be exposed.

Do not connect switching cards directly to unlimited power circuits. They are intended to be used with impedance-limited sources. NEVER connect switching cards directly to AC mains. When connecting sources to switching cards, install protective devices to limit fault current and voltage to the card.

Before operating an instrument, ensure that the line cord is connected to a properly-grounded power receptacle. Inspect the connecting cables, test leads, and jumpers for possible wear, cracks, or breaks before each use.

When installing equipment where access to the main power cord is restricted, such as rack mounting, a separate main input power disconnect device must be provided in close proximity to the equipment and within easy reach of the operator.

For maximum safety, do not touch the product, test cables, or any other instruments while power is applied to the circuit under test. ALWAYS remove power from the entire test system and discharge any capacitors before: connecting or disconnecting cables or jumpers, installing or removing switching cards, or making internal changes, such as installing or removing jumpers.

Do not touch any object that could provide a current path to the common side of the circuit under test or power line (earth) ground. Always make measurements with dry hands while standing on a dry, insulated surface capable of withstanding the voltage being measured.

The instrument and accessories must be used in accordance with its specifications and operating instructions, or the safety of the equipment may be impaired.

Do not exceed the maximum signal levels of the instruments and accessories, as defined in the specifications and operating information, and as shown on the instrument or test fixture panels, or switching card.

When fuses are used in a product, replace with the same type and rating for continued protection against fire hazard.

Chassis connections must only be used as shield connections for measuring circuits, NOT as safety earth ground connections.

If you are using a test fixture, keep the lid closed while power is applied to the device under test. Safe operation requires the use of a lid interlock.

If a  screw is present, connect it to safety earth ground using the wire recommended in the user documentation.

The  symbol on an instrument indicates that the user should refer to the operating instructions located in the user documentation.

The  symbol on an instrument shows that it can source or measure 1000V or more, including the combined effect of normal and common mode voltages. Use standard safety precautions to avoid personal contact with these voltages.

The  symbol on an instrument shows that the surface may be hot. Avoid personal contact to prevent burns.

The  symbol indicates a connection terminal to the equipment frame.

If this  symbol is on a product, it indicates that mercury is present in the display lamp. Please note that the lamp must be properly disposed of according to federal, state, and local laws.

The **WARNING** heading in the user documentation explains dangers that might result in personal injury or death. Always read the associated information very carefully before performing the indicated procedure.

The **CAUTION** heading in the user documentation explains hazards that could damage the instrument. Such damage may invalidate the warranty.

Instrumentation and accessories shall not be connected to humans.

Before performing any maintenance, disconnect the line cord and all test cables.

To maintain protection from electric shock and fire, replacement components in mains circuits - including the power transformer, test leads, and input jacks - must be purchased from Keithley Instruments. Standard fuses with applicable national safety approvals may be used if the rating and type are the same. Other components that are not safety-related may be purchased from other suppliers as long as they are equivalent to the original component (note that selected parts should be purchased only through Keithley Instruments to maintain accuracy and functionality of the product). If you are unsure about the applicability of a replacement component, call a Keithley Instruments office for information.

To clean an instrument, use a damp cloth or mild, water-based cleaner. Clean the exterior of the instrument only. Do not apply cleaner directly to the instrument or allow liquids to enter or spill on the instrument. Products that consist of a circuit board with no case or chassis (e.g., a data acquisition board for installation into a computer) should never require cleaning if handled according to instructions. If the board becomes contaminated and operation is affected, the board should be returned to the factory for proper cleaning/servicing.

Table of Contents

1 General Information

1.1	Introduction	1-1
1.2	Features	1-1
1.3	Warranty information	1-2
1.4	Manual addenda	1-2
1.5	Safety symbols and terms	1-2
1.6	Specifications	1-2
1.7	Inspection	1-2
1.8	Options and accessories	1-2

2 Front Panel Operation

2.1	Introduction	2-1
2.2	Power-up	2-1
2.2.1	Line power connections	2-1
2.2.2	Line fuse replacement	2-2
2.2.3	Power-up sequence	2-2
2.2.4	High energy circuit safety precautions	2-4
2.2.5	Power-on default conditions	2-4
2.2.6	Warm-up period	2-4
2.2.7	IEEE-488 primary address	2-4
2.3	Display	2-4
2.3.1	Multiple displays	2-4
2.3.2	Information messages	2-7
2.3.3	Status and error messages	2-7
2.3.4	Navigating menus	2-9
2.4	Functions	2-9
2.4.1	DC and AC voltage	2-9
2.4.2	DC and AC current	2-23
2.4.3	Two and four-wire resistance	2-28
2.4.4	Frequency	2-32
2.4.5	Temperature	2-33
2.5	Range	2-40
2.5.1	Display resolution	2-40
2.5.2	Maximum readings	2-40
2.5.3	Manual ranging	2-40
2.5.4	Autoranging	2-40
2.6	Relative	2-40
2.6.1	Configuring rel	2-41
2.6.2	Enabling rel	2-41

2.6.3	Multiple display of rel	2-41
2.7	Triggers	2-41
2.7.1	Trigger model	2-41
2.7.2	Configuring the measure layer	2-46
2.7.3	Configuring the scan layer	2-48
2.7.4	Configuring the arm layer	2-49
2.7.5	Halting triggers	2-50
2.7.6	External triggering	2-50
2.7.7	Trigger Link	2-53
2.8	Buffer	2-64
2.8.1	Burst mode	2-65
2.8.2	Configuring data storage	2-67
2.8.3	Storing and recalling readings	2-69
2.8.4	Buffer multiple displays	2-70
2.9	Filter	2-71
2.9.1	Filter types	2-71
2.9.2	Filter modes	2-71
2.9.3	Response time	2-73
2.9.4	Auto filtering	2-73
2.9.5	Configuring the filters	2-74
2.10	Math	2-75
2.10.1	Polynomial	2-75
2.10.2	Percent	2-76
2.10.3	Percent deviation	2-76
2.10.4	Selecting and configuring math	2-76
2.10.5	Calculate multiple display	2-77
2.11	Scanning	2-77
2.11.1	Scanning overview	2-77
2.11.2	Front panel scanner controls	2-77
2.11.3	Using CHAN key to close and open internal channels	2-78
2.11.4	Using CONFIGURE CHAN to configure channels	2-79
2.11.5	Using CONFIG-SCAN to configure scanning	2-80
2.11.6	Using SCAN to configure scan parameters	2-81
2.11.7	Starting and stopping scanning	2-83
2.11.8	Scanner operation examples	2-83
2.12	Menu	2-87
2.12.1	SAVESETUP	2-90
2.12.2	GPIB	2-96
2.12.3	CALIBRATION	2-96
2.12.4	TEST	2-97
2.12.5	LIMITS	2-97
2.12.6	STATUS-MSG	2-99
2.12.7	GENERAL	2-99

3 IEEE-488 Reference

3.1	Introduction	3-1
3.2	IEEE-488 bus connections	3-1
3.3	Primary address selection	3-2
3.4	QuickBASIC 4.5 programming	3-3
3.5	General bus commands	3-4
3.5.1	REN (remote enable)	3-4
3.5.2	IFC (interface clear)	3-4

3.5.3	LLO (local lockout)	3-4
3.5.4	GTL (go to local)	3-5
3.5.5	DCL (device clear)	3-5
3.5.6	SDC (selective device clear)	3-5
3.5.7	GET (group execute trigger)	3-5
3.5.8	SPE, SPD (serial polling)	3-5
3.6	Front panel aspects of IEEE-488 operation	3-5
3.6.1	Error and status message	3-5
3.6.2	IEEE-488 status indicators	3-5
3.6.3	LOCAL key	3-6
3.7	Status structure	3-6
3.7.1	Condition registers	3-8
3.7.2	Transition filters	3-8
3.7.3	Event registers	3-8
3.7.4	Enable registers	3-8
3.7.5	Queues	3-16
3.7.6	Status byte and service request (SRQ)	3-16
3.8	Trigger model (IEEE-488 operation)	3-18
3.9	Programming syntax	3-23
3.10	Common commands	3-29
3.10.1	*CLS — clear status	3-29
3.10.2	*ESE <NRf> — event enable	3-30
	*ESE? — event enable query	3-30
3.10.3	*ESR? — event status register query	3-31
3.10.4	*IDN? — identification query	3-32
3.10.5	*OPC — operation complete	3-33
3.10.6	*OPC? — operation complete query	3-34
3.10.7	*OPT? — option identification query	3-35
3.10.8	*RCL — recall	3-35
3.10.9	*RST — reset	3-36
3.10.10	*SAV — save	3-36
3.10.11	*SRE <NRf> — service request enable	3-36
	*SRE? — service request enable query	3-36
3.10.12	*STB? — status byte query	3-38
3.10.13	*TRG — trigger	3-39
3.10.14	*TST? — self-test query	3-39
3.10.15	*WAI — wait-to-continue	3-40
3.11	Signal oriented measurement commands	3-41
3.12	Calculate subsystem	3-67
3.12.1	:CALCulate[1]	3-67
3.12.2	:CALCulate2	3-69
3.12.3	:CALCulate3	3-71
3.13	:DISPlay subsystem	3-76
3.14	:FORMat subsystem	3-79
3.15	:INPut subsystem	3-84
3.16	:OUTPut subsystem	3-85
3.17	:ROUte subsystem	3-86
3.17.1	:CLOSe <list>	3-86
3.17.2	:OPEN <list>	3-86
3.17.3	:OPEN:ALL	3-87
3.17.4	:SCAN commands	3-87
3.18	Sense subsystems	3-91
3.18.1	[:SENSe[1]] subsystem	3-91
3.18.2	:ALTerNate[1] commands	3-91

3.18.3	:FUNctIon <name>	3-91
3.18.4	:DATA commands	3-92
3.18.5	:APERTure <n>	3-93
3.18.6	:NPLCycles <n>	3-94
3.18.7	:COUPling AC DC	3-96
3.18.8	RANGe commands	3-96
3.18.9	:REFErence <n>	3-99
3.18.10	:DIGits <n>	3-101
3.18.11	:AVERage commands	3-102
3.18.12	[:FUNCTION] <name>	3-105
3.18.13	:PWINDow <n>	3-106
3.18.14	:METHod <name>	3-106
3.18.15	:SOURce <name>	3-106
3.18.16	THReshold commands	3-107
3.18.17	:TRANsducer <name>	3-108
3.18.18	:RTD commands	3-109
3.18.19	:TCouple:TYPE <name>	3-111
3.18.20	:RJUNctionX commands	3-112
3.18.21	:OCOMpensated 	3-114
3.18.22	:DTCouple commands	3-114
3.18.23	:SENSe2 subsystem	3-115
3.19	:SOURce subsystem	3-116
3.20	:STATus subsystem	3-117
3.20.1	[:EVENT]?	3-117
3.20.2	:ENABle <NRf>	3-122
3.20.3	:PTRansition <NRf>	3-125
3.20.4	:NTRansition <NRf>	3-132
3.20.5	:CONDition?	3-134
3.20.6	:PRESET	3-134
3.20.7	:QUEue commands	3-135
3.21	:SYSTem subsystem	3-137
3.21.1	:PRESet	3-137
3.21.2	:POSetup <name>	3-137
3.21.3	:FRSWitch?	3-137
3.21.4	:VERsion?	3-138
3.21.5	:ERRor?	3-138
3.21.6	:AZERo commands	3-138
3.21.7	:AMETHod <name>	3-139
3.21.8	:LSYNc:STATe 	3-143
3.21.9	:KEY <NRf>	3-143
3.21.10	:CLEar	3-145
3.21.11	:LFRequency	3-145
3.21.12	:DATE <yr>, <mo>, <day>	3-145
3.21.13	:TIME <hr>, <min>, <sec>	3-145
3.21.14	:TSTamp commands	3-146
3.21.15	:RNUMber:RESet	3-146
3.22	:TRACe subsystem	3-147
3.22.1	:CLEar	3-147
3.22.2	:FREE?	3-147
3.22.3	:EGRoup <name>	3-147
3.22.4	:POINTs <n>	3-148
3.22.5	:FEED <name>	3-148
3.22.6	:DATA?	3-151
3.22.7	:TSTamp:FORMat <name>	3-151

3.23	Trigger subsystem	3-152
3.23.1	:INITiate commands	3-152
3.23.2	:ABORt	3-152
3.23.3	:IMMediate	3-152
3.23.4	:COUNt <n>	3-153
3.23.5	:DELay <n>	3-153
3.23.6	:SOURce <name>	3-154
3.23.7	:TIMer <n>	3-154
3.23.8	:SIGNal	3-155
3.23.9	TCONfigure commands	3-155
3.23.10	RTCLock commands	3-157
3.24	:UNIT subsystem	3-159

A	Specifications
B	Interface Function Codes
C	ASCII Character Codes and IEEE-488 Multiline Interface Command Messages
D	IEEE-488 Bus Overview
E	IEEE-488 Conformance Information
F	SCPI Conformance Information
G	Example Programs
H	HP3458A Emulation Mode

List of Illustrations

2	Front Panel Operation	
Figure 2-1	Bar graph (zero-at-left) multiple display	2-6
Figure 2-2	Zero-centered bar graph multiple display	2-6
Figure 2-3	Maximum and minimum multiple display	2-7
Figure 2-4	Positive and negative peak spikes	2-15
Figure 2-5	DC voltage multifunction multiple displays	2-16
Figure 2-6	AC voltage multifunction multiple displays	2-20
Figure 2-7	DC in-circuit current measurements	2-26
Figure 2-8	AC current multifunction multiple displays	2-28
Figure 2-9	3-wire RTD temperature measurements	2-34
Figure 2-10	2-wire RTD temperature measurements	2-35
Figure 2-11	Temperature equations	2-38
Figure 2-12	Trigger model (front panel operation)	2-44
Figure 2-13	External triggering connectors (BNC)	2-50
Figure 2-14	External triggering and asynchronous trigger link input pulse specifications	2-50
Figure 2-15	Meter complete and asynchronous trigger link output pulse specifications	2-51
Figure 2-16	DUT test system	2-51
Figure 2-17	External trigger connectors	2-52
Figure 2-18	Trigger link connectors	2-53
Figure 2-19	DUT test system	2-54
Figure 2-20	Trigger Link connections (asynchronous example #1)	2-54
Figure 2-21	Operation model for asynchronous trigger link example #1	2-56
Figure 2-22	Connections using Trigger Link adapter	2-57
Figure 2-23	DUT test system (asynchronous example #2)	2-57
Figure 2-24	Trigger Link connections (asynchronous example #2)	2-58
Figure 2-25	Operation model for asynchronous Trigger Link example #2	2-60
Figure 2-26	Semi-synchronous Trigger Link specifications	2-61
Figure 2-27	Typical semi-synchronous mode connections	2-61
Figure 2-28	Trigger Link connections (semi-synchronous example)	2-62
Figure 2-29	Operation mode for semi-synchronous Trigger Link example	2-63
Figure 2-30	Averaging and advanced filter types	2-72
Figure 2-31	Moving and repeating filter modes	2-73
Figure 2-32	SCAN key menu structure	2-82
Figure 2-33	SCAN key menu structure for ratio and delta	2-83
Figure 2-34	Limits bar graph example	2-98
Figure 2-35	Using limit test to start 100Ω resistor	2-99
Figure 2-36	Digital I/O port	2-100
Figure 2-37	Digital I/O port simplified schematic	2-101
Figure 2-38	Sample externally powered relay sample	2-102
Figure 2-39	Line cycle synchronization	2-104

3

IEEE-488 Reference

Figure 3-1	IEEE-488 connector	3-2
Figure 3-2	IEEE-488 connections	3-2
Figure 3-3	IEEE-488 connector location	3-2
Figure 3-4	Model 2002 status register structure	3-7
Figure 3-5	Standard event status	3-9
Figure 3-6	Operation event status	3-10
Figure 3-7	Arm event status	3-11
Figure 3-8	Sequence event status	3-12
Figure 3-9	Trigger event status	3-13
Figure 3-10	Measurement event status	3-14
Figure 3-11	Questionable event status	3-15
Figure 3-12	Status byte and service request (SRQ)	3-17
Figure 3-13	Trigger Model (IEEE-488 bus operation)	3-19
Figure 3-14	Standard Event Enable Register	3-31
Figure 3-15	Standard Event Status Register	3-32
Figure 3-16	Service Request Enable Register	3-37
Figure 3-17	Status Byte Register	3-39
Figure 3-18	ASCII data format	3-79
Figure 3-19	IEEE754 single precision data format (32 data bits)	3-80
Figure 3-20	IEEE754 double precision data format (64 data bits)	3-81
Figure 3-21	Measurement Event Register	3-118
Figure 3-22	Questionable Event Register	3-119
Figure 3-23	Operation Event Register	3-120
Figure 3-24	Trigger Event Register	3-120
Figure 3-25	Arm Event Register	3-121
Figure 3-26	Sequence Event Register	3-121
Figure 3-27	Measurement Event Enable Register	3-123
Figure 3-28	Questionable Event Enable Register	3-123
Figure 3-29	Operation Event Enable Register	3-124
Figure 3-30	Trigger Event Enable Register	3-124
Figure 3-31	Arm Event Enable Register	3-124
Figure 3-32	Sequence Event Enable Register	3-125
Figure 3-33	Measurement Transition Filter	3-126
Figure 3-34	Questionable Transition Filter	3-127
Figure 3-35	Operation Transition Filter	3-128
Figure 3-36	Trigger Transition Filter	3-129
Figure 3-37	Arm Transition Filter	3-130
Figure 3-38	Sequence Transition Filter	3-131
Figure 3-39	Key-press codes	3-144

D

IEEE-488 Bus Overview

Figure D-1	IEEE-488 bus configuration	D-2
Figure D-2	IEEE-488 handshake sequence	D-3
Figure D-3	Command codes	D-6

List of Tables

2 Front Panel Operation

Table 2-1	Data checked on power-up	2-3
Table 2-2	Power-up error messages	2-3
Table 2-3	Multiple displays by function	2-5
Table 2-4	Status and error messages	2-8
Table 2-5	EXIT key actions	2-9
Table 2-6	CONFIGURE DCV menu structure	2-10
Table 2-7	CONFIGURE ACV menu structure	2-11
Table 2-8	DCV and ACV integration times set-by-resolution	2-12
Table 2-9	DCV and ACV auto filter	2-13
Table 2-10	DCV and ACV auto resolution	2-13
Table 2-11	CONFIGURE DCI menu structure	2-24
Table 2-12	CONFIGURE ACI menu structure	2-24
Table 2-13	DCI and ACI integration time set-by-resolution	2-25
Table 2-14	DCI and ACI auto filter	2-25
Table 2-15	DCI and ACI auto resolution	2-26
Table 2-16	CONFIGURE OHMS-2W menu structure	2-29
Table 2-17	CONFIGURE OHMS-4W menu structure	2-29
Table 2-18	$\Omega 2$ and $\Omega 4$ integration time set-by-resolution	2-30
Table 2-19	$\Omega 2$ and $\Omega 4$ auto filter	2-30
Table 2-20	$\Omega 2$ and $\Omega 4$ auto resolution	2-31
Table 2-21	Trigger level range and increments	2-32
Table 2-22	CONFIGURE FREQUENCY menu structure	2-33
Table 2-23	CONFIG TEMPERATURE menu structure	2-36
Table 2-24	Temperature integration time set-by-resolution	2-39
Table 2-25	Temperature auto resolution	2-39
Table 2-26	Allowable rel values	2-41
Table 2-27	CONFIGURE TRIGGER menu structure	2-42
Table 2-28	Reading storage options	2-64
Table 2-29	CONFIGURE DATA STORE menu structure	2-65
Table 2-30	Available functions in burst mode	2-66
Table 2-31	Burst mode sequence	2-67
Table 2-32	Fill-and-stop sequence	2-69
Table 2-33	Continuous sequence	2-70
Table 2-34	Pretrigger sequence	2-70
Table 2-35	Auto filters	2-74
Table 2-36	CONFIGURE FILTER menu structure	2-74
Table 2-37	CONFIGURE MATH menu structure	2-76
Table 2-38	CHANNEL SELECTION menu structure	2-78
Table 2-39	CONFIGURE CHANNELS menu structure	2-79
Table 2-40	SCAN OPERATION menu structure	2-81
Table 2-41	Main menu structure	2-88
Table 2-42	Factory default conditions	2-91

3 IEEE-488 Reference

Table 3-1	General bus commands and associated statements	3-4
Table 3-2	IEEE-488.2 common commands and queries	3-29
Table 3-3	Signal oriented measurement command summary	3-41
Table 3-4	CALCulate command summary	3-46
Table 3-5	DISPlay command summary	3-48
Table 3-6	FORMat command summary	3-48
Table 3-7	INPut command summary	3-49
Table 3-8	OUTput command summary	3-49
Table 3-9	ROUte command summary	3-50
Table 3-10	SENSe command summary	3-50
Table 3-11	SOURce command summary	3-59
Table 3-12	STATus command summary	3-60
Table 3-13	SYSTem command summary	3-62
Table 3-14	TRACe command summary	3-63
Table 3-15	Trigger command summary	3-63
Table 3-16	UNIT command summary	3-65
Table 3-17	Minimum delay times for stream mode	3-142

B Interface Function Codes

Table B-1	Model 2002 interface function codes	B-1
-----------	---	-----

D IEEE-488 Bus Overview

Table D-1	IEEE-488 bus command summary	D-4
Table D-2	Hexadecimal and decimal command codes	D-7
Table D-3	Typical addressed command sequence	D-7
Table D-4	Typical common command sequence	D-7
Table D-5	IEEE command groups	D-8

E IEEE-488 Conformance Information

Table E-1	IEEE-488 documentation requirements	E-1
Table E-2	Coupled commands	E-3

H HP3458A Emulation Mode

Table H-1	Commands not supported by HP3458A emulation mode	H-2
Table H-2	Supported HP3458A commands	H-3

General Information

1.1 Introduction

This section contains general information about the Model 2002 Multimeter. It is arranged in the following manner:

1.2 Features

1.3 Warranty information

1.4 Manual addenda

1.5 Safety symbols and terms

1.6 Specifications

1.7 Inspection

1.8 Options and accessories

1.2 Features

Some important Model 2002 features include:

- Full range of functions — Among other functions, the multimeter can measure DC voltage (normal and peak spikes), AC voltage (RMS, average, and peak), DC current (normal and in-circuit), AC current (RMS and average), two and four-wire resistance (normal and offset-compensated), frequency (voltage and current), and temperature (resistance temperature devices or thermocouples).
- Two-line display — Readings and front panel messages are shown on an alphanumeric display having a 20-character top line and a 32-character bottom line.
- Multifunction measuring and display — From the front panel, you can configure the instrument to sequentially measure and simultaneously display readings of multiple functions.
- Reading and setup storage — Readings and setup data can be stored and recalled from the front panel or over the IEEE-488 bus. For example, the buffer can be programmed to store up to 850 readings at 4.5 digits, or up to 250 time-stamped readings at 6.5 digits. The Model 2002 can be configured with memory options that extend the storage capacity up to 30,000 readings and ten setups.
- High-speed measurements — The instrument is capable of acquiring, for example, 2000 readings/second at 4.5 digits of resolution, and 215 readings/second at 6.5 digits.
- Talk-only mode — From the front panel, you can set the instrument to send readings to an IEEE-488 printer or, with an optional adapter, to a Centronics printer.
- Digital calibration — The instrument may be digitally calibrated from either the front panel or over the bus.
- Standard IEEE-488 interface — Bus operation conforms to the IEEE-488.2 and SCPI standards.
- Trigger link — This is a new trigger concept that provides more versatile and precise external triggering. It is in addition to the standard Trigger In/Measurement Complete BNC external triggering techniques.
- Optional field-installable internal scanner — This is a 10-channel scanner card, which includes eight channels of 2-pole relay switching and two channels of 2-pole solid-state switching. All channels can be configured for 4-pole operation.

1.3 Warranty information

Warranty information is located on the inside front cover of this instruction manual. Should your Model 2002 require warranty service, contact the Keithley representative or authorized repair facility in your area for further information. When returning the instrument for repair, be sure to fill out and include the service form at the back of this manual to provide the repair facility with the necessary information.

1.4 Manual addenda

Any improvements or changes concerning the instrument or manual will be explained in an addendum included with the manual. Be sure to note these changes and incorporate them into the manual.

1.5 Safety symbols and terms

The following symbols and terms may be found on an instrument or used in this manual.

The  symbol on an instrument indicates that the user should refer to the operating instructions located in the manual.

The  symbol on an instrument shows that high voltage may be present on the terminal(s). Use standard safety precautions to avoid personal contact with these voltages.

The **WARNING** heading used in this manual explains dangers that might result in personal injury or death. Always read the associated information very carefully before performing the indicated procedure.

The **CAUTION** heading used in this manual explains hazards that could damage the instrument. Such damage may invalidate the warranty.

1.6 Specifications

Full Model 2002 specifications are included in Appendix A.

1.7 Inspection

The Model 2002 was carefully inspected, both electrically and mechanically before shipment. After unpacking all items from the shipping carton, check for any obvious signs of physical damage that may have occurred during transit. (Note: There may be a protective film over the display lens,

which can be removed.) Report any damage to the shipping agent immediately. Save the original packing carton for possible future reshipment. The following items are included with every Model 2002 order:

- Model 2002 Multimeter (with MEM1 or MEM2 memory option, if ordered) with line cord.
- Model 8605 High Performance Modular Test Leads.
- Model 2002 User's Manual and Model 2002 Calibration Manual.
- Accessories as ordered.
- Full calibration data (conforming to MIL-STD 45662A).

If an additional manual is required, order the appropriate manual package:

- Keithley part number 2002-900-00 for the User's Manual.
- Keithley part number 2002-902-00 for the Repair Manual.
- Keithley part number 2002-903-00 for the Getting Started Manual.
- Keithley part number 2002-905-00 for the Calibration Manual.

The manual packages include a manual and any pertinent addenda.

1.8 Options and accessories

The following options and accessories are available from Keithley for use with the Model 2002.

Model 1050 Padded Carrying Case: A carrying case for a Model 2002 or a Model 7001. Includes handles and shoulder strap.

Models 2002/MEM1 and 2002/MEM2: These optional configurations of the Model 2002 extend its storage capacity. The MEM1 option has 32K-bytes for non-volatile storage of five setups, and 7000 readings in compact format or 1400 readings in full format. The MEM2 option has 128K-bytes for non-volatile storage of ten setups, and 30000 compact readings or 6000 full readings.

Model 2001-SCAN: This is a 10-channel scanner card that installs within the Model 2002. It has eight channels of 2-pole relay switching and two channels of 2-pole solid-state switching. All channels can be configured for 4-pole operation. Included are two pairs of leads for connection to Model 2002 rear panel inputs (Keithley part number CA-109).

Model 2001-TCSCAN: This is a thermocouple/general purpose scanner card that installs in the option slot of the Model 2002. The card has nine analog input channels that can be used for high-accuracy, high-speed scanning. A built-in temperature reference allows multi-channel, cold-junction compensated temperature measurements using thermocouples.

Model 4288-1 Single Fixed Rack Mount Kit: Mounts a single Model 2002 in a standard 19-inch rack.

Model 4288-2 Side-by-side Rack Mount Kit: Mounts two instruments (Models 182, 428, 486, 487, 2001, 2002, 7001) side-by-side in a standard 19-inch rack.

Model 4288-3 Side-by-side Rack Mount Kit: Mounts a Model 2002 and a Model 199 side-by-side in a standard 19-inch rack.

Model 4288-4 Side-by-side Rack Mount Kit: Mounts a Model 2002 and a 5 -inch instrument (Models 195A, 196, 220, 224, 230, 263, 595, 614, 617, 705, 740, 775, etc.) side-by-side in a standard 19-inch rack.

Models 7007-1 and 7007-2 Shielded IEEE-488 Cables: Connect the Model 2002 to the IEEE-488 bus using shielded cables and connectors to reduce electromagnetic interference (EMI). The Model 7007-1 is one meter long; the Model 7007-2 is two meters long.

Models 8501-1 and 8501-2 Trigger Link Cables: Connect the Model 2002 to other instruments with Trigger Link connectors (e.g., Model 7001 Switch System). The Model 8501-1 is one meter long; the Model 8501-2 is two meters long.

Model 8502 Trigger Link Adapter: Allows you to connect the Trigger Link of the Model 2002 to instruments that use the standard BNC (In/Out) external triggering technique.

Model 8530 IEEE-488 to Centronics Printer Adapter Cable: Translates the IEEE-488 connector pinout and signal level to a Centronics termination. This permits a standard Centronics parallel printer to be connected to a Model 2002 in TALK-ONLY mode.

Model 8605 High Performance Modular Test Leads: Consists of two high voltage (1000V) test probes and leads. The test leads are terminated with a banana plug with retractable sheath on each end. (Each Model 2002 is shipped with one set of these test leads.)

Model 8606 High Performance Probe Tip Kit: Consists of two spade lugs, two alligator clips, and two spring hook test probes. (The spade lugs and alligator clips are rated at 30V

RMS, 42.4V peak; the test probes are rated at 1000V.) These components are designed to be used with high performance test leads terminated with banana plugs, such as the Model 8605 High Performance Modular Test Leads.

The following test leads and probes are rated at 30V RMS, 42.4V peak:

Models 5805 and 5805-12 Kelvin Probes: Consists of two spring-loaded Kelvin test probes with banana plug termination. Designed to be used with instruments that measure 4-terminal resistance. The Model 5805 is 0.9m long; the Model 5805-12 is 3.6m long.

Model 5806 Kelvin Clip Lead Set: Includes two Kelvin clip test leads (0.9m) with banana plug termination. Designed for instruments that measure 4-terminal resistance. A set of eight replacement rubber bands for the Model 5806 is available as Keithley P/N GA-22.

Model 8604 SMD Probe Set: Consists of two test leads (3ft), each terminated with a surface mount device “grabber” clip on one end and a banana plug with retractable sheath on the other end.

Model 8610 Low Thermal Shorting Plug: Consists of four banana plugs mounted to a 1-inch square circuit board, interconnected to provide a short circuit among all plugs.

Model 8611 Low Thermal Patch Leads: Consists of two test leads (3ft), each with a banana plug with a retractable sheath at each end. These leads minimize the thermally-induced offsets that can be created by test leads.

Model 8612 Low Thermal Spade Leads: Consists of two test leads (3ft), each terminated with a spade lug on one end and a banana plug with a retractable sheath on the other end. These leads minimize the thermally-induced offsets that can be created by test leads.

Model 8680 RTD Probe Adapter: This adapts RTDs with terminated and unterminated cables to instruments with banana jacks for measuring 4-terminal resistance. It has a 4-pin “T”-style connector and a 4-pin screw terminal block.

Model 8681 Miniature RTD Surface Probe: This is a low cost platinum 4-wire-RTD with unterminated wires. It is designed to measure the temperature of flat surfaces or free space.

Model 8693 General Purpose/Immersion RTD Probe: This probe has a platinum RTD sensor. It is designed for immersion in liquids as well as other general purpose applications.

Model 8695 Surface RTD Probe: This probe has a platinum RTD sensor. It is designed to measure the temperature of flat surfaces of solids.

Model 8696 Air/Gas RTD Probe: This probe has a platinum RTD sensor. It has an exposed junction within a protective shroud for measuring the temperature of air or gases.

2

Front Panel Operation

2.1 Introduction

This section contains detailed reference information for front panel operation of the Model 2002. It is organized as follows:

- 2.2 Power-up:** Covers information on connecting the instrument to line power, warm-up period, default conditions, and the power-up sequence.
- 2.3 Display:** Covers display format and messages that may appear while using the instrument.
- 2.4 Functions:** Describes the measurement functions of the instrument (DC and AC voltage, DC and AC current, 2-wire and 4-wire resistance, frequency, and temperature).
- 2.5 Range:** Covers both manual and autoranging operation.
- 2.6 Relative:** Gives details on using the relative feature that can be used to null offsets or subtract a baseline value from present and future readings.
- 2.7 Triggering:** Details types of trigger modes as well as trigger sources that can be used.
- 2.8 Buffer:** Covers use of the reading buffer including programming buffer size and recalling data, time stamp, and statistics information.
- 2.9 Filter:** Covers the use of the digital filter types that can be used to reduce reading noise.

2.10 Math: Describes the calculations that can be performed on readings in continuous operation.

2.11 Scanning: Discusses setting up internal and external scans, along with ratio and delta calculations.

2.12 Menu: Covers selections controlled from the main menu, such as saving instrument setups, GPIB (IEEE-488 bus) configuration, calibration, self-tests, limits, and the digital I/O port.

2.2 Power-up

2.2.1 Line power connections

Follow the procedure below to connect the Model 2002 to line power and turn on the instrument.

1. The Model 2002 operates from a line voltage in the range of 90-134V or 180-250V at a frequency of 50, 60, or 400Hz. Check to see that the operating voltage in your area is compatible.

CAUTION

Operating the instrument on an incorrect line voltage may cause damage to the instrument, possibly voiding the warranty.

2. Before plugging in the power cord, make sure the front panel power switch is in the off (0) position.
3. Connect the female end of the supplied power cord to the AC receptacle on the rear panel. Connect the other end of the power cord to a grounded AC outlet.

WARNING

The power cord supplied with the Model 2002 contains a separate ground wire for use with grounded outlets. When proper connections are made, instrument chassis is connected to power line ground through the ground wire in the power cord. Failure to use a grounded outlet may result in personal injury or death due to electric shock.

2.2.2 Line fuse replacement

A rear panel fuse located below the AC receptacle protects the power line input of the instrument. If the fuse needs to be replaced, perform the following steps:

WARNING

Make sure the instrument is disconnected from the power line and other equipment before replacing the line fuse.

1. With the power off, place the end of a flat-blade screwdriver into the rear panel LINE FUSE holder. Push in gently and rotate the fuse carrier one-quarter turn counterclockwise. Release pressure on the holder and its internal spring will push the fuse carrier out of the holder.
2. Remove the fuse and replace it with the same type (0.5A, 250V, slow blow, 5 × 20mm). The Keithley part number is FU-71.

CAUTION

Do not use a fuse with a higher current rating than specified, or instrument damage may occur. If the instrument repeatedly blows fuses, locate and correct the cause of the trouble before replacing the fuse. See the optional Model 2002 Repair Manual for troubleshooting information.

3. Install the new fuse and fuse carrier into the holder by reversing the above procedure.

2.2.3 Power-up sequence

On power-up, the Model 2002 performs self-tests on its EPROM and RAM, and checksum tests on data stored in non-volatile memory. (See Table 2-1.) If a failure is detected, the instrument momentarily displays an error message and the ERR annunciator turns on. (Messages are listed in Table 2-2.)

NOTE

If a problem develops while the instrument is under warranty, return it to Keithley Instruments, Inc. for repair.

If the instrument passes the self-tests, the firmware revision levels, memory option (if installed), and presently selected IEEE-488 primary address are displayed. An example of this display is shown as follows:

```
Model 2002
Rev. A01 A01 MEM1 IEEE Addr=16
```

The firmware revision levels (left to right) are for the main microcontroller and display microcontroller. The revision level number may be different in your particular unit. If the MEM1 or MEM2 memory options are not present, that portion of the bottom line is left blank. The IEEE-488 address is its default value of 16.

Next, if the unit is configured to display the calibration due date at power-up, the unit shows the following:

```
Model 2002
Calibration due: mmm/dd/yy
```

where “mmm” is the month abbreviation, “dd” is the day, and “yy” is the year. If no calibration date is set, the display shows that it is due now. (See the Model 2002 Calibration Manual to set the calibration due date and paragraph 2.12.3 of this manual to set the display option.)

After the power-up sequence, the instrument begins its normal display, for example:

```
000.0000 mVDC
```

Power-up error messages

Error messages that may be displayed during power-up are summarized in Table 2-2. These are shown when one of the checksum tests of Table 2-1 fails.

Table 2-1
Data checked on power-up

Data	Type of storage	Memory option
IEEE-488 address	Electrically-erasable PROM	STD, MEM1, MEM2
Power-on default	Electrically-erasable PROM	STD, MEM1, MEM2
Calibration constants	Electrically-erasable PROM	STD, MEM1, MEM2
Calibration dates	Electrically-erasable PROM	STD, MEM1, MEM2
Instrument setups	1 in electrically-erasable PROM 4 more in non-volatile RAM 9 more in non-volatile RAM	STD, MEM1, MEM2 MEM1 MEM2
Reading buffer	(Volatile RAM) Non-volatile RAM	STD MEM1, MEM2

Note: STD is standard memory, MEM1 is memory option #1, MEM2 is memory option #2.

Table 2-2
Power-up error messages

Message	Action
Error +515, Calibration dates lost	The cal dates are set to factory default values, but they are not stored into EEPROM. To do this, perform a comprehensive calibration.
Error +514, DC calibration data lost	DC cal constants are set to factory default values, but they are not stored into EEPROM. To do this, perform a comprehensive calibration.
Error +513, AC calibration data lost	AC cal constants are set to factory default values, but they are not stored into EEPROM. To do this, perform a comprehensive calibration.
Error +512, Power-on state lost	Power-on defaults are reset to factory defaults (bench) and stored into EEPROM.
Error +511, GPIB address lost	GPIB address is reset to factory default (16) and stored into EEPROM.
Error +510, Reading buffer data lost	The reading buffer controls are reset to factory defaults, but they are not stored into NVRAM. To do this, store readings in the buffer.
Error -314, Save/recall memory lost	Instrument setup is reset to bench defaults and stored into EEPROM.

Notes:

1. Any of these error conditions may occur the first time a unit is turned on or after replacing the firmware.
2. Error +510, Reading buffer data lost, applies to units with optional memory.
3. Error +512, Power-on state lost, may occur the first time the unit is powered-up after replacing the MEM2 memory option with MEM1.

2.2.4 High energy circuit safety precautions

To optimize safety when measuring voltage in high energy distribution circuits, read and use the directions in the following warning.

WARNING

Dangerous arcs of an explosive nature in a high energy circuit can cause severe personal injury, or death. If the multimeter is connected to a high energy circuit when set to a current range, low resistance range, or any other low impedance range, the circuit is virtually shorted. Dangerous arcing can result even when the multimeter is set to a voltage range if the minimum voltage spacing is reduced.

When making measurements in high energy circuits, use test leads that meet the following requirements:

- Test leads should be fully insulated.
- Only use test leads that can be connected to the circuit (e.g., alligator clips, spade lugs, etc.) for hands-off measurements.
- Do not use test leads that decrease voltage spacing. This diminishes arc protection and creates a hazardous condition.

Use the following sequence when testing power circuits:

1. De-energize the circuit using the regular installed connect-disconnect device, such as a circuit breaker, main switch, etc.
2. Attach the test leads to the circuit under test. Use appropriate safety rated test leads for this application.
3. Set the multimeter to the proper function and range.
4. Energize the circuit using the installed connect-disconnect device and make measurements without disconnecting the multimeter.
5. De-energize the circuit using the installed connect-disconnect device.
6. Disconnect the test leads from the circuit under test.

WARNING

The maximum common-mode voltage (voltage between INPUT LO and chassis ground) is 500V peak. Exceeding this value may cause a breakdown in insulation, creating a shock hazard.

2.2.5 Power-on default conditions

Power-on default conditions are those conditions the instrument assumes when it is first turned on. You can change these power-on default conditions (except the primary address) by using the save setup feature that is available with the MENU key, as described in paragraph 2.12.1. Depending on the installed memory option, either one, five, or ten user-defined setups can be stored, any one of which could be selected as the power-on default.

Table 2-42 in paragraph 2.12.1 lists the default conditions that are set at the factory to optimize bench and GPIB (IEEE-488) operation.

2.2.6 Warm-up period

The Model 2002 can be used within one minute after it is turned on. However, the instrument should be turned on and allowed to warm up for at least four hours before use to achieve rated accuracy.

2.2.7 IEEE-488 primary address

The IEEE-488 primary address of the instrument must be the same as the primary address you specify in the controller's programming language. The default primary address of the instrument is 16, but you can set the address to any value from 0 to 30 by using the MENU key. Refer to paragraph 2.12.2 for step-by-step instructions on setting the primary address. Section 4 contains details on using the Model 2002 over the IEEE-488 bus.

2.3 Display

The display of the Model 2002 is primarily used to display readings along with the units and type of measurement. When not displaying readings, it is used for informational messages, such as menu headings and selections. At the top of the display are annunciators to indicate various states of operation. The Getting Started manual covers the display basics.

2.3.1 Multiple displays

Each measurement function has its own set of "multiple displays" shown on the bottom line of the front panel display. The PREVIOUS and NEXT DISPLAY keys scroll through the selections for the present function.

Some of the multiple displays are for multiple functions, where different functions are measured sequentially from the same set of test leads. The readings are shown simultaneously, such as:

- Top line shows a DC voltage measurement; bottom line shows positive and negative peak spike measurements.
- Top line shows an AC RMS voltage reading; bottom line shows an AC frequency measurement and a crest factor calculation.

Also, the multiple displays can show a reading in a different form, or give additional information about the reading, for example:

- Top line shows a reading; bottom line shows a zero-centered bar graph with adjustable limits.

- Top line shows a frequency measurement; bottom line shows the adjustable trigger level.

To scroll through the multiple displays available for each measurement function, repeatedly press and release the NEXT DISPLAY key. The same action with the PREVIOUS DISPLAY key does a reverse scroll through the displays. To return to the default reading display, just press and hold either key.

Multiple displays that are specific to a particular function or operation are discussed later in this section, such as the peak spikes displays in DC voltage, and the calculations display in math. (See Table 2-3 for paragraph references.) Displays that are common to most of the measurement functions are discussed here.

Table 2-3
Multiple displays by function

Function	Next display	Paragraph
All	Bar graph	2.3.1
	Zero-centered bar graph	2.3.1
	Maximum and minimum values	2.3.1
	Relative and actual values	2.6
	Calculated and actual values (see Note 1)	2.10
	Limits bar graph (see Note 1)	2.12.5
	Adjacent channel readings (see Note 2)	2.11
DC voltage	DC volts, AC ripple voltage and frequency	2.4.1
	Positive peak spikes and highest value	
	Negative peak spikes and lowest value	
AC voltage	Positive and negative peak spikes	
	AC RMS voltage, frequency, and crest factor	2.4.1
DC current	AC RMS, average, and peak voltages	
	(none specific to function)	2.4.2
AC current	AC RMS (or average) current and frequency	2.4.2
	AC RMS and average current	
2-wire resistance	Source current	2.4.3
	Voltage drop across DUT	
4-wire resistance	Source current	2.4.3
	Voltage drop across DUT	
	Lead resistance	
Frequency	Period calculation	2.4.4
	Trigger level	
Temperature	Celsius, Fahrenheit, and Kelvin units	2.4.5
	RTD resistance (or thermocouple voltage)	
	Reference junction (thermocouples only)	
Data storage buffer	Maximum and minimum values	2.8
	Average and standard deviation	

Notes:

1. Multiple displays for calculated values and limits bar graph are not available for the frequency function.
2. The multiple display for adjacent channel readings is not available for the DC and AC current functions.

Bar graph

The “normal” bar graph, with a zero at the left end, is a graphical representation of a reading as a portion of a range. (See Figure 2-1.) The vertical lines displayed along the bar designate 0%, 25%, 50%, 75%, and 100% of full scale. Each full segment of the bar represents approximately 4% of the range limit.

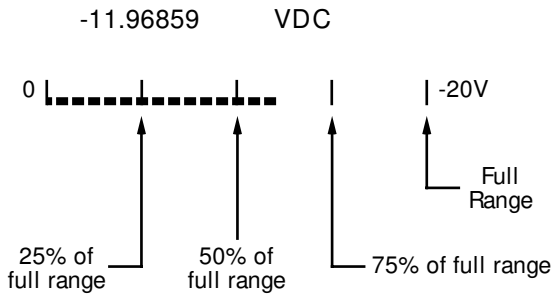

Figure 2-1
Bar graph (zero-at-left) multiple display

For measurement functions with a range (voltage, current, and resistance), the right endpoint of the bar graph is plus full scale of the present range for positive readings, and minus full scale for negative readings. When the 100% line changes to an arrow, the reading exceeds the present range.

Note that the normal bar graph is not available when the ACV units are dB or dBm.

For functions without a range (frequency and temperature), the right endpoint of the bar graph is user-programmable by pressing either CONFIG-NEXT DISPLAY or CONFIG-PREV DISPLAY. Note that these configuration menus are context-sensitive. If the unit is in any function except frequency or temperature, CONFIG-NEXT DISPLAY results in the zero bar graph configuration display.

Perform the following to view or change the range of the bar graph:

1. From the frequency or temperature function, press the CONFIG key and then the NEXT or PREV DISPLAY key. The following menu is displayed:

```
BARGRAPH TYPE
ZERO-AT-LEFT ZERO-CENTERED
```

2. Use the cursor keys (◀ and ▶) to place the cursor on ZERO-AT-LEFT and press ENTER. You will access one of the following menus:

For frequency:

```
FREQ BARGRAPH RANGE
2Hz 20Hz 200Hz 2kHz 20kHz ▶
◀ 200kHz 2MHz 15MHz
```

For temperature:

```
BARGRAPH:0 to 0040°C
```

3. Change the frequency range by highlighting one of the selections and pressing ENTER. For the temperature range, use the cursor keys and the RANGE ▲ and ▼ keys to enter a numeric value (0 - 9999°C). Press ENTER when done.

Zero-centered bar graph

The zero-centered bar graph is a graphical representation of a reading with plus and minus limits. (See Figure 2-2.) The limits are expressed in a user-selectable percentage of range for voltage, current, and resistance, and a user-selectable value for frequency and temperature.

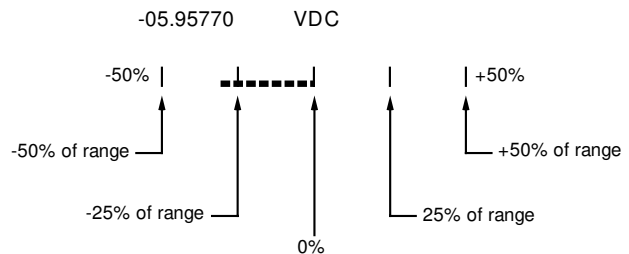

Figure 2-2
Zero-centered bar graph multiple display

The vertical lines displayed along the bar designate the plus and minus limits, zero, and halfway to either limit. There are ten full segments between zero and each end, so each full segment represents 10% of the limit. When a line at the limit changes to an arrow, the reading exceeds the programmed range.

The plus and minus percentage of range that is programmed (0.01 - 99.99%) applies to all voltage, current, and resistance functions. Because of rounding, values greater than 99.5% are shown as 100% and, likewise, values greater than 1% (such as 1.67%) are shown rounded to the nearest integer percent.

Note that the zero-centered bar graph is not available when the ACV units are dB or dBm.

Perform the following to view or change the plus and minus percentage of range:

1. From a voltage, current, or resistance function, press CONFIG and then NEXT or PREV DISPLAY. The following is displayed:

ZERO-BARGRAPH±50.00%

2. Change the percentage by using the cursor keys and the RANGE ▲ and ▼ keys to enter a numeric value (0.01 - 99.99%). Press ENTER when done. The same percentage of range is used for voltage, current, and resistance measurements.

Perform the following to view or change the plus and minus value limit:

1. From the frequency or temperature function, press CONFIG and then NEXT or PREV DISPLAY. The following menu is displayed:

BARGRAPH TYPE
ZERO-AT-LEFT ZERO-CENTERED

2. Use the cursor keys (◀ and ▶) to place the cursor on ZERO-CENTERED and press ENTER. You will access one of the following menus:

For frequency:

FREQ ZEROBARGRAPH(±)
1Hz 10Hz 100Hz 1kHz 10kHz ▶
◀ 100kHz 1MHz 10MHz 15MHz

For temperature:

ZERO-BARGRAPH±0002°C

3. Change the frequency limits by highlighting one of the selections and pressing ENTER. For the temperature, use the cursor keys and the RANGE ▲ and ▼ keys to enter a numeric value (0 - 9999°C). Press ENTER when done.

Maximum and minimum

The maximum and minimum multiple display shows the maximum and minimum readings since the display was entered. (See Figure 2-3.) The maximum and minimum values are reset by the following:

- Pressing the present function key.
- Leaving the display by changing function or entering a menu.

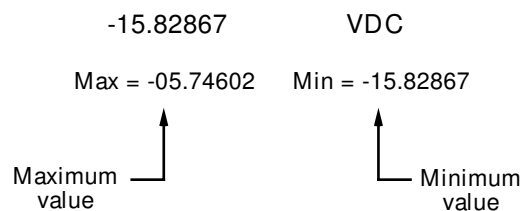

Figure 2-3
Maximum and minimum multiple display

The resolution, units, and prefix on the bottom line are the same as shown for top line reading. If necessary, the bottom line values automatically change to scientific notation, rounded to 4.5 digits.

2.3.2 Information messages

Press the INFO key to view context-sensitive information from most of the displays. An arrow (◀ or ▶) on the bottom line indicates that there is more information. Use the cursor keys (◀ and ▶) to view the complete line. To exit an INFO display, just press INFO, ENTER, EXIT, or a function key.

2.3.3 Status and error messages

During Model 2002 operation and programming, you will encounter a number of front panel messages. Typical messages are either of status or error variety, as listed in Table 2-4.

The most recent status or error messages can be momentarily displayed. Just enter a configuration menu or the main menu, and press the PREV key. (The display is blank if no message is queued.)

Table 2-4
Status and error messages

Number	Description	Event
+900	“Internal System Error”	EE
+611	“Questionable Temperature”	SE
+610	“Questionable Calibration”	SE
+519	“Excessive temp drift during cal”	EE
+518	“Low level calibration data lost”	EE
+517	“Preamp calibration data lost”	EE
+516	“Install option id lost”	EE
+515	“Calibration dates lost”	EE
+514	“DC calibration data lost”	EE
+513	“AC calibration data lost”	EE
+512	“Power-on state lost”	EE
+511	“GPIB address lost”	EE
+510	“Reading buffer data lost”	EE
+444 to	Calibration Errors	EE
+350	(see Calibration Manual)	
+312	“Buffer pretriggered”	SE
+311	“Buffer lost”	SE
+310	“Buffer full”	SE
+309	“Buffer half full”	SE
+308	“Buffer Available”	SE
+307	“Voltmeter complete”	SE
+306	“Reading Available”	SE
+305	“High limit 2 event”	SE
+304	“Low limit 2 event”	SE
+303	“High limit 1 event”	SE
+302	“Low limit 1 event”	SE
+301	“Reading overflow”	SE
+174	“Re-entering the idle layer”	SE
+173	“Waiting in arm layer 2”	SE
+172	“Waiting in arm layer 1”	SE
+171	“Waiting in trigger layer”	SE
+161	“Program running”	SE
+126	“Device calculating”	SE
+125	“Device measuring”	SE
+124	“Device sweeping”	SE
+123	“Device ranging”	SE
+122	“Device settling”	SE
+121	“Device calibrating”	SE
+101	“Operation complete”	SE
+000	“No error”	SE
-100	“Command error”	EE
-101	“Invalid character”	EE
-102	“Syntax error”	EE
-103	“Invalid separator”	EE
-104	“Data type error”	EE
-105	“GET not allowed”	EE
-108	“Parameter not allowed”	EE
-109	“Missing parameter”	EE
-110	“Command header error”	EE
-111	“Header separator error”	EE
-112	“Program mnemonic too long”	EE

Table 2-4
Status and error messages (cont.)

Number	Description	Event
-113	“Undefined header”	EE
-114	“Header suffix out of range”	EE
-120	“Numeric data error”	EE
-121	“Invalid character in number”	EE
-123	“Exponent too large”	EE
-124	“Too many digits”	EE
-128	“Numeric data not allowed”	EE
-140	“Character data error”	EE
-141	“Invalid character data”	EE
-144	“Character data too long”	EE
-148	“Character data not allowed”	EE
-150	“String data error”	EE
-151	“Invalid string data”	EE
-154	“String too long”	EE
-158	“String data not allowed”	EE
-160	“Block data error”	EE
-161	“Invalid block data”	EE
-168	“Block data not allowed”	EE
-170	“Expression error”	EE
-171	“Invalid expression”	EE
-178	“Expression data not allowed”	EE
-200	“Execution error”	EE
-201	“Invalid while in local”	EE
-202	“Settings lost due to rtl” (return to local)	EE
-210	“Trigger error”	EE
-211	“Trigger ignored”	EE
-212	“Arm ignored”	EE
-213	“Init ignored”	EE
-214	“Trigger deadlock”	EE
-215	“Arm deadlock”	EE
-220	“Parameter Error”	EE
-221	“Settings conflict”	EE
-222	“Parameter data out of range”	EE
-223	“Too much data”	EE
-224	“Illegal parameter value”	EE
-230	“Data corrupt or stale”	EE
-241	“Hardware missing”	EE
-260	“Expression Error”	EE
-281	“Cannot create program”	EE
-282	“Illegal program name”	EE
-314	“Save/recall memory lost”	EE
-315	“Configuration memory lost”	EE
-330	“Self Test failed”	EE
-350	“Queue overflow”	EE
-410	“Query interrupted”	EE
-420	“Query unterminated”	EE
-430	“Query deadlocked”	EE
-440	“Query unterminated after indefinite response”	EE

SE = Status event
EE = Error event

2.3.4 Navigating menus

There are basically two types of menu structures; the Main Menu and the Configure menus. The Main Menu accesses items for which there are no dedicated keys, and Configure menus are used to configure measurement functions and other instrument operations.

Use the following rules to navigate through the menu structure:

1. The top level of the Main Menu is accessed by pressing the MENU key. A Configuration menu is accessed by pressing CONFIG and then the desired function (DCV, ACV, etc.) or operation (TRIG, STORE, etc.).
2. A menu item is selected by placing the cursor on it and pressing ENTER. Cursor position is denoted by the blinking menu item or parameter. The cursor keys (◀ and ▶) control cursor position.
3. A displayed arrow (◀ and ▶) on the bottom line indicates that there are one or more additional items (messages) to select from. Use the appropriate cursor key to display them.
4. A numeric parameter is keyed in by placing the cursor on the digit to be changed and using the RANGE ▲ or ▼ key to increment or decrement the digit.
5. A change is only executed when ENTER is pressed. Entering an invalid parameter generates an error and the entry is ignored.
6. The EXIT key is used to back out of the menu structure. Any change that is not entered is cancelled when EXIT is pressed. The EXIT key has additional actions and are summarized in Table 2-5.

2.4 Functions

To minimize the need to reprogram setup conditions every time you switch from one function to another, each function

“remembers” its own unique setup configuration. Setup configuration parameters that are remembered include:

- Range
- Relative
- Integration time
- Filtering
- Display resolution
- Multiple displays

To access the configuration menus for the measurement functions, press the CONFIG key and then a function key (DCV, ACV, DCI, ACI, Ω2, Ω4, FREQ, TEMP). Rules for navigating the menu structures are covered in paragraph 2.3.4.

2.4.1 DC and AC voltage

The Model 2002 can make DCV measurements from 1nV to 1100V and ACV measurements from 10nV to 775V. The basic measurement procedures for DCV and ACV are contained in the Getting Started manual.

Voltage configuration

The following information explains the various configuration options for DC and AC voltage measurements. The configuration menus are summarized in Tables 2-6 and 2-7. The menus are accessed by pressing CONFIG and then DCV or ACV. Paragraph 2.3.5 summarizes the rules for navigating through menus.

Note that a function does not have to be selected in order to be configured. When the function is selected, it will assume the programmed status.

Table 2-5
EXIT key actions

Condition	EXIT key action
Temporary message displayed (e.g., TRIGGERS HALTED)	Cancels display of temporary message.
INFO message displayed	Cancels INFO message, returns to menu or normal reading display.
Reading display hold	Cancels reading display hold, resumes normal reading display.
Scanning	Disables scanning. Also stops data storage if enabled.
Data storage	Stops data storage. Temporary message STORAGE INTERRUPTED is displayed.

Table 2-6
CONFIGURE DCV menu structure

Menu item	Description
SPEED NORMAL FAST MEDIUM HIACCURACY SET-SPEED-EXACTLY SET-BY-RSLN	Measurement speed (integration time) menu: Select 1 PLC (power line cycle, 16.67msec for 60Hz, 20msec for 50Hz and 400Hz). Select 0.01 PLC. Select 0.1 PLC. Select 10 PLC. Set integration time in PLC (0.01-50). Default to setting appropriate for resolution.
FILTER AUTO AVERAGING ADVANCED AVERAGING-MODE	Digital filter menu: Default to filter appropriate for integration time. Program a simple average filter (1-100 readings). Program a simple average filter (1-100 readings) with a noise tolerance window (0-100% of range). Select moving average or repeating average mode.
RESOLUTION AUTO 3.5d, 4.5d, 5.5d, 6.5d, 7.5d, 8.5d	Display resolution menu: Default to resolution appropriate for integration time. Select a specific resolution.

Table 2-7
CONFIGURE ACV menu structure

Menu item	Description
SPEED NORMAL FAST MEDIUM HIACCURACY SET-SPEED-EXACTLY SET-BY-RSLN	Measurement speed (integration time) menu: Select 1 PLC (power line cycle, 16.67msec for 60Hz, 20msec for 50Hz and 400Hz). Select 0.01 PLC. Select 0.1 PLC. Select 10 PLC. Set integration time in PLC (0.01-50). Default to setting appropriate for resolution.
FILTER AUTO AVERAGING ADVANCED AVERAGING-MODE	Digital filter menu: Default to filter appropriate for integration time. Program a simple average filter (1-100 readings). Program a simple average filter (1-100 readings) with a noise tolerance window (0-100% of range). Select moving average or repeating average mode.
RESOLUTION AUTO 3.5d, 4.5d, 5.5d, 6.5d, 7.5d, 8.5d	Display resolution menu: Default to resolution appropriate for integration time. Select a specific resolution.
UNITS VOLTS dB dBm	Display units menu: Select volts. Select dB and set voltage reference level. Select dBm and set reference impedance.
COUPLING AC AC+DC	Coupling menu: Select AC coupled measurements. Select DC coupled measurements.
AC-TYPE RMS AVERAGE PEAK LOW-FREQ-RMS POSITIVE-PEAK NEGATIVE-PEAK	Type of ACV measurement menu: Select true RMS ACV. Select average ACV. Select peak ACV. Select low frequency (typically <50Hz) true RMS ACV. Select positive DCV peak spikes measurements. Select negative DCV peak spikes measurements.

SPEED

The SPEED parameter sets the integration time of the A/D converter, the period of time the input signal is measured (also known as aperture). The integration time affects the usable resolution, the amount of reading noise, as well as the ultimate reading rate of the instrument. From the front panel, the integration time is specified in parameters based on a number of power line cycles (NPLC), where 1 PLC for 60Hz is 16.67msec and 1 PLC for 50Hz and 400Hz is 20msec.

The SPEED parameters for all functions (except frequency) are explained as follows:

FAST: Sets integration time to 0.01 PLC. Use FAST if speed is of primary importance at the expense of increased reading noise and less usable resolution.

MEDIUM: Sets integration time to 0.1PLC. Use MEDIUM when a compromise between noise performance and speed is acceptable.

NORMAL: Sets integration time to 1 PLC. A compromise like MEDIUM, but NORMAL provides better noise performance at the expense of speed.

HIACCURACY: Sets integration time to 10 PLC. Use HI-ACCURACY when high common-mode and normal-mode rejection is required.

SET-SPEED-EXACTLY: When this parameter is selected, the current PLC value is displayed. By using the cursor keys (◀ and ▶) and the RANGE ▲ and ▼ keys, you can enter any PLC value from 0.01 to 50. Be sure to press ENTER after keying in a new value. Note that an integer PLC value will increase noise rejection.

SET-BY-RSLN: This parameter optimizes the integration time for the present resolution setting. See Table 2-8 for the default integration times of the DCV and ACV functions. The default set-by-resolution integration times of other functions are listed in Tables 2-13, 2-18 and 2-24.

FILTER

FILTER lets you set the digital filter response. The filter menu is available from the function configuration menus (i.e. CONFIGURE DCV) or by pressing CONFIGURE FILTER with the desired function already selected. All of the parameters (menu items) for FILTER are explained in paragraph 2.9. Since the AUTO parameter has specific effects on DCV and ACV, it is covered here.

AUTO: This parameter for a digital filter optimizes its use for the present measurement function. The defaults for automatic filtering of DCV and ACV are listed in Table 2-9.

Table 2-8
DCV and ACV integration times set-by-resolution

Measurement function and type	Resolution	Integration time
DCV	3.5d, 4.5d	0.01 PLC
	5.5d	0.02 PLC
	6.5d	0.10 PLC
	7.5d	1.00 PLC
	8.5d	10.00 PLC
DCV peak spikes	3.5d (to 7.5d)	Not used
RMS, average	3.5d, 4.5d	0.01 PLC
	5.5d	0.02 PLC
	6.5d, 7.5d, 8.5d	10.00 PLC
Low frequency RMS	3.5d to 8.5d	Not used
ACV peak	4d (to 8d)	Not used

Notes:

1. For DCV measurements, if the integration time is SET-BY-RSLN and the resolution AUTO, the integration time will be 1.0 PLC and the resolution 7.5 digits.
2. For RMS and average measurements, if the integration time is SET-BY-RSLN and the resolution is AUTO, the integration will be 1.0 PLC and the resolution 5.5 digits.
3. For DCV peak spikes, low frequency RMS, and ACV peak measurements, the integration time setting is ignored.
4. The resolution of DCV peak spikes can be from 3.5d to 8.5d, but the accuracy is specified at 3.5d. The resolution of ACV peak can be from 4d to 8d, but the accuracy is specified at 4d.

Table 2-9
DCV and ACV auto filter

Measurement function and type	Units	State	Type	Readings	Noise tolerance	Averaging Mode
DCV	-	On	Advanced	10	1.0%	Moving
DCV peak spikes	-	On	Advanced	10	5.0%	Moving
RMS, average, low frequency RMS	Any	Off	Advanced	10	5.0%	Moving
ACV peak	Volts	On	Advanced	10	5.0%	Moving
	dB, dBm	On	Averaging	10	-	Moving

RESOLUTION

Except for frequency, temperature, and some special cases of AC voltage, all functions can operate with 3 to 8 -digit resolution, or they can default to a setting appropriate for the selected integration time.

3.5d, 4.5d, 5.5d, 6.5d, 7.5d or 8.5d: Sets resolution to the specified number of digits.

AUTO: optimizes the resolution for the present integration time setting. See Table 2-10 for the default resolutions of the DCV and ACV functions. The default resolutions of the other functions are listed in Tables 2-15, 2-20 and 2-25.

UNITS

This parameter selects the displayed units for AC voltage measurements.

VOLTS: With volts selected as the units, AC voltage measurements are expressed in volts.

dB: Expressing AC voltage in dB makes it possible to compress a large range of measurements into a much smaller scope. The relationship between dB and voltage is defined by the following equation:

$$dB = 20 \log \frac{V_{IN}}{V_{REF}}$$

where: V_{IN} is the AC input signal.
 V_{REF} is the specified voltage reference level.

Table 2-10
DCV and ACV auto resolution

Measurement function and type	Integration time	Resolution
DCV	0.01 to <0.02 PLC	4.5d
	0.02 to <0.10 PLC	5.5d
	0.10 to <1.00 PLC	6.5d
	1.00 to <10.00 PLC	7.5d
	10.00 to 50 PLC	8.5d
DCV peak spikes	Not used	3.5d
RMS, average	0.01 to <0.02 PLC	4.5d
	0.02 to <10.00 PLC	5.5d
	10.00 to 50 PLC	6.5d
Low frequency RMS	Not used	5.5d
ACV peak	Not used	4d

Notes:

1. If the DCV resolution is AUTO and the integration time SET-BY-RSLN, the resolution will be 7.5 digits and the integration time 1.0 PLC.
2. For DCV peak spikes, low frequency RMS, and ACV peak measurements, the integration time setting is ignored.
3. For RMS and average measurements, if the resolution is AUTO and the integration time is SET-BY-RSLN, the resolution will be 5.5 digits and the integration time 1.0 PLC.

The instrument will read 0dB when the reference voltage level is applied to the input. dB measurements are possible on all ACV measurement types except positive peak spikes and negative peak spikes, as these may be negative, and the log of a negative number is not defined. Note that dB mea-

measurements are specified only for the low frequency RMS measurement type.

If a relative value is in effect when dB is selected, the value is converted to dB. If a relative value is stored after dB units are selected, the units of the relative value are dB.

After selecting dB, the present reference voltage level is displayed. To change the reference level, use the cursor keys (◀ and ▶) and the RANGE ▲ and ▼ keys. Be sure to press ENTER after changing the reference level.

dBm: dBm is defined as decibels above or below a 1mW reference. With a user-programmable reference impedance, the Model 2002 reads 0dBm when the voltage needed to dissipate 1mW through the reference impedance is applied. The relationship between dBm, a reference impedance, and the voltage is defined by the following equation:

$$\text{dBm} = 10 \log \frac{(V_{\text{IN}}^2/Z_{\text{REF}})}{1\text{mW}}$$

where: V_{IN} is the AC input signal.
 Z_{REF} is the specified reference impedance.

NOTE

Do not confuse reference impedance with input impedance. The input impedance of the instrument is not modified by the dBm parameter.

If a relative value is in effect when dBm is selected, the value is converted to dBm. If a relative value is stored after dBm units are selected, the units of the relative value is dBm.

To set the reference impedance, perform the following steps:

After selecting dBm, the present reference impedance is displayed (1-9999Ω). To change the reference impedance, use the cursor keys (◀ and ▶) and the RANGE ▲ and ▼ keys. Be sure to press ENTER after changing the reference impedance.

dB/dBm notes:

1. dB and dBm units are not allowed with positive or negative peak spike measurements.
2. dB and dBm units are not allowed with an advanced filter.
3. With dB or dBm units selected, there is no bar graph or zero-centered bar graph multiple display.

4. When units are changed from volts to dB or dBm, all values less than zero that depend on the new units are made equal to zero. This includes, for example, relative values and stored readings. This avoids the overflow condition of a log of a negative number.

COUPLING

This parameter selects the input coupling for the ACV function.

AC: With AC coupling selected, a DC blocking capacitor is placed in series with the input. This removes the DC component from the RMS, average or peak ACV measurement.

AC+DC: When AC+DC coupling is selected, the blocking capacitor is removed. Subsequent RMS, average or peak ACV measurements reflect both the AC and DC components of the signal.

While displaying readings, the present coupling setting is shown on the bottom line, if not showing a multiple display.

Note that the coupling settings for ACV and ACI are discrete. Thus, setting the coupling of ACV has no effect on the coupling of ACI.

AC-TYPE

This parameter selects the measurement type for the ACV function. The Model 2002 directly measures RMS, average, and peak AC voltages. For a 330V peak-to-peak sine wave, which is line voltage in the U.S., the measurements would be:

- RMS = 117V
- Average = 105V (full wave rectified)
- Peak AC = 165V

The peak detector is also used to measure positive and negative peak spikes riding on a DC signal and they are, therefore, also configured from the AC-TYPE menu.

RMS and LOW-FREQ-RMS: Selecting between normal RMS mode and low frequency RMS mode depends on the desired accuracy and speed. Low frequency RMS mode is more accurate, but slower.

Both modes are specified between 20Hz and 2MHz, with low frequency RMS specified additionally down to 1Hz. Some guidelines for choosing between the two modes follow:

- Below 50Hz, use low frequency RMS mode for its greater accuracy.

- Between 50 and 100Hz, use either mode.
- Above 100Hz, use normal RMS mode for its greater speed.

AVERAGE: When this item is selected, the signal path in the instrument bypasses the RMS converter, and the average ACV measurement is the filtered output of a full wave rectifier.

PEAK: For AC peak measurements, the instrument displays the largest peak (positive or negative) of the input signal. The measurement window is fixed at 100msec.

Note that you can configure the resolution of ACV peak measurements from 4 digits (3.5d from SET ACV RESOLUTION menu) to 9 digits (8.5d), but the accuracy is specified at 4 digits. In addition, the accuracy specifications for AC peak measurements assume AC+DC coupling below 200Hz.

POSITIVE-PEAK and NEGATIVE-PEAK: Peak spike measurements are available as an ACV primary display (top line). They are also available as a DCV multiple display (bottom line). The menu items POSITIVE-PEAK and NEGATIVE-PEAK enable the measurement as a primary display. See Figure 2-4 for a description of the primary display.

After selecting a positive or negative peak spikes measurement from the SET ACV MEASUREMENT menu, you are asked to enter a value for the measurement window. A typical message follows:

PEAK WINDOW = 0.1 s

This sets the time the signal is sampled before the display is updated with a new reading. It can range from 0.1sec to 9.9sec.

As a primary display, the resolution of peak spikes can be set from 3.5d to 8.5d, but the accuracy is specified at 3.5d. (As a multiple display, the resolution is fixed at 3.5d.)

Note that dB and dBm are not allowed as valid units for peak spikes. Positive-going spikes on a negative DC level could still read as a negative value, and the log of a negative number is not defined.

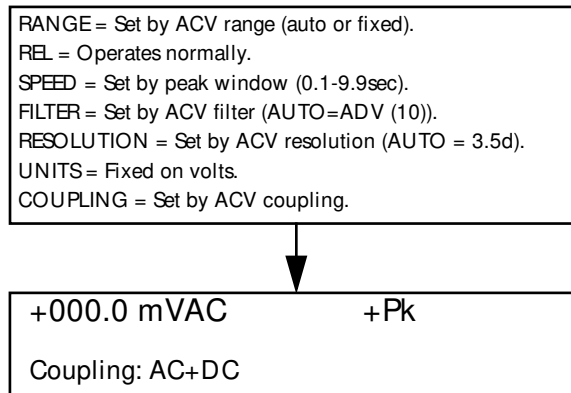

NOTES:

1. Positive peak spikes and negative peak spikes are selected in the CONFIGURE-ACV menu.
2. Peak spikes measurement is specified for volts at 3.5 digits.
3. "Peak window" is the time a signal is sampled before a reading is displayed.

Figure 2-4
Positive and negative peak spikes

Multiple displays

The displays for DC and AC voltage that show multiple functions are shown in Figures 2-5 and 2-6. The multiple display for crest factor, which is calculated from the peak and RMS values, is described here.

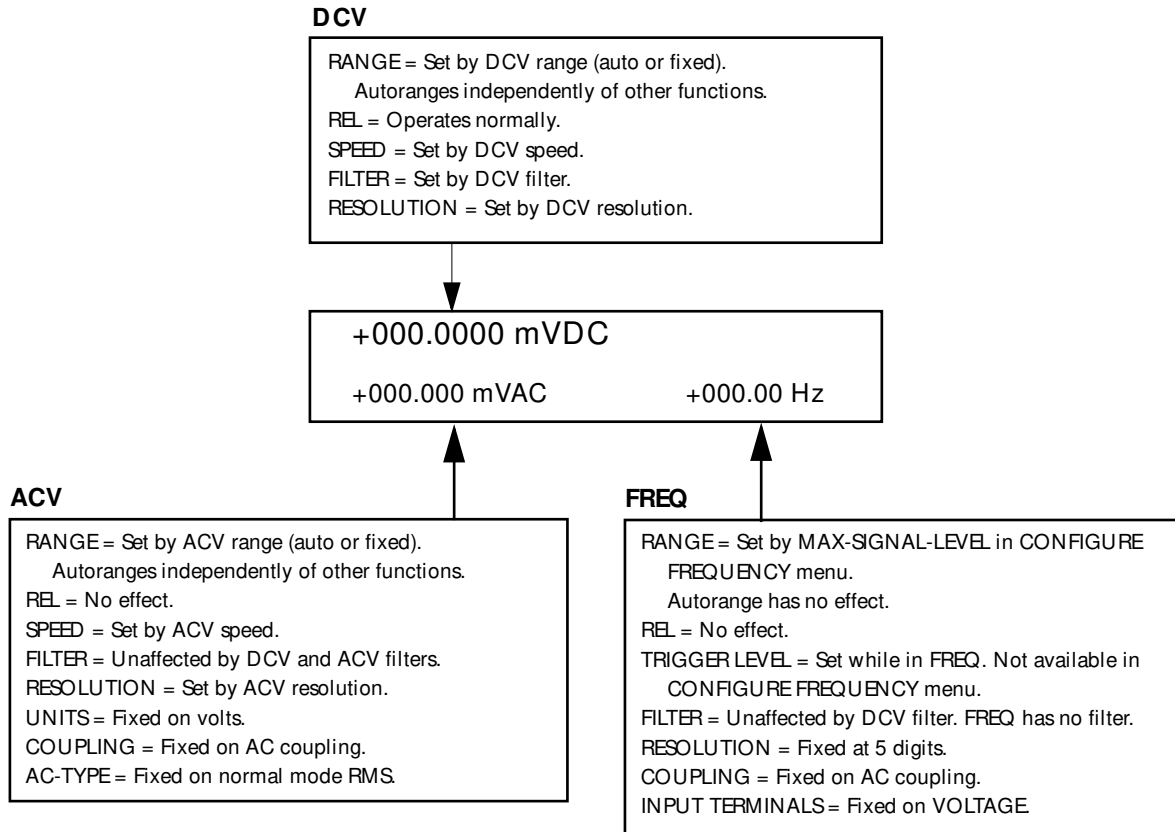

A. DC voltage, AC voltage, and frequency functions

Figure 2-5

DC voltage multifunction multiple displays

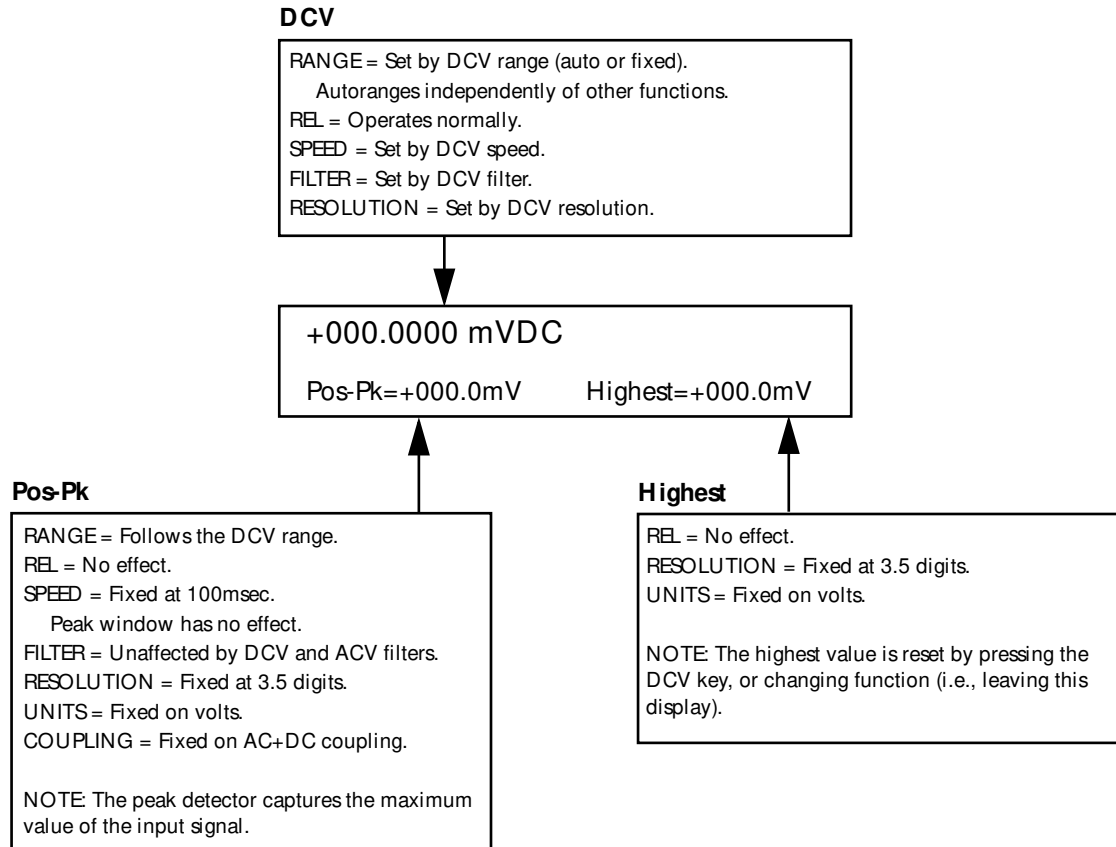

B. DC voltage and positive peak spikes functions

Figure 2-5
 DC voltage multifunction multiple displays (cont.)

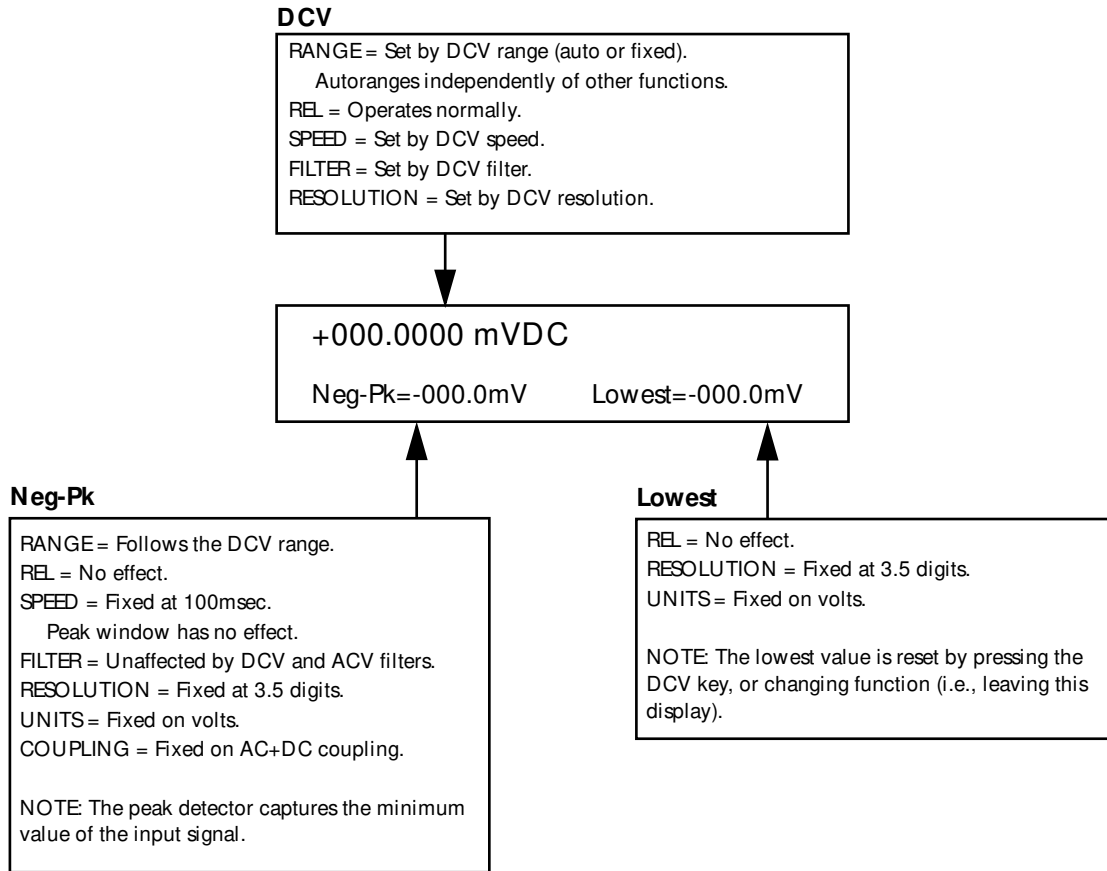

C. DC voltage and negative peak spikes functions

Figure 2-5
DC voltage multifunction multiple displays (cont.)

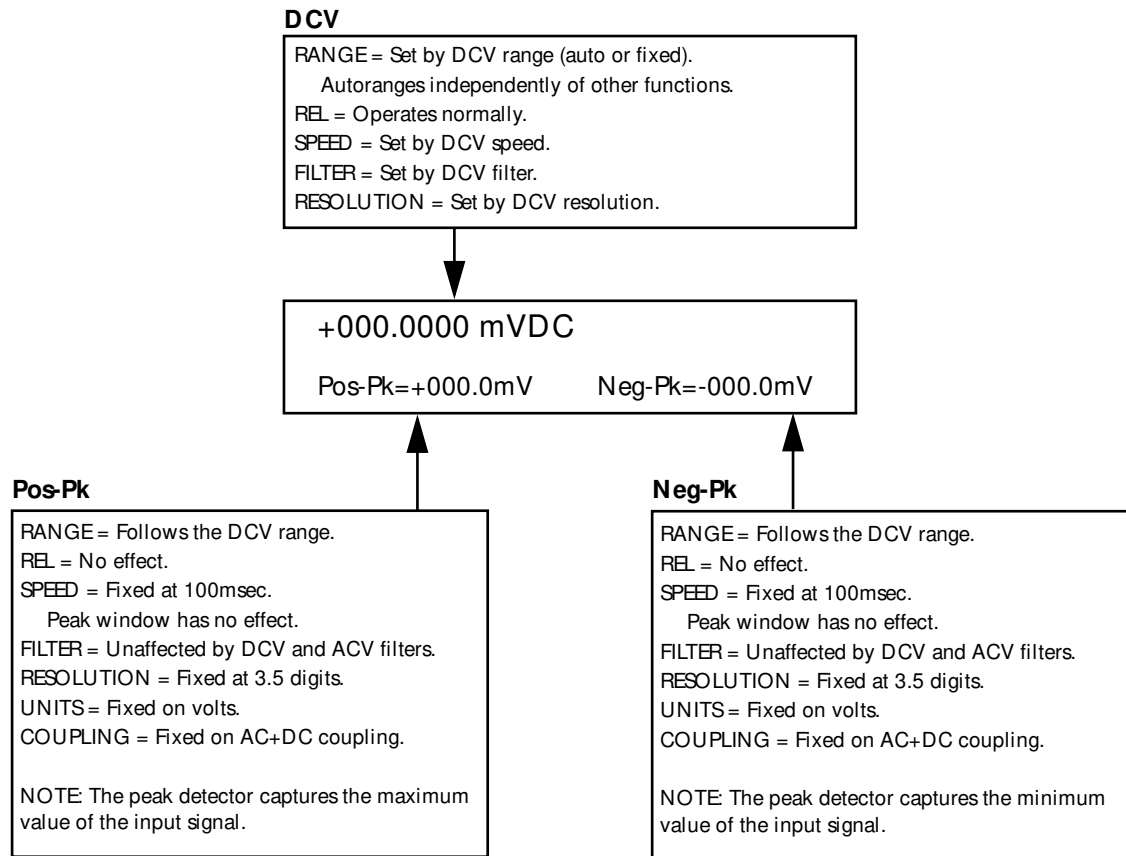

D. DC voltage, positive and negative peak spikes functions

Figure 2-5
 DC voltage multifunction multiple displays (cont.)

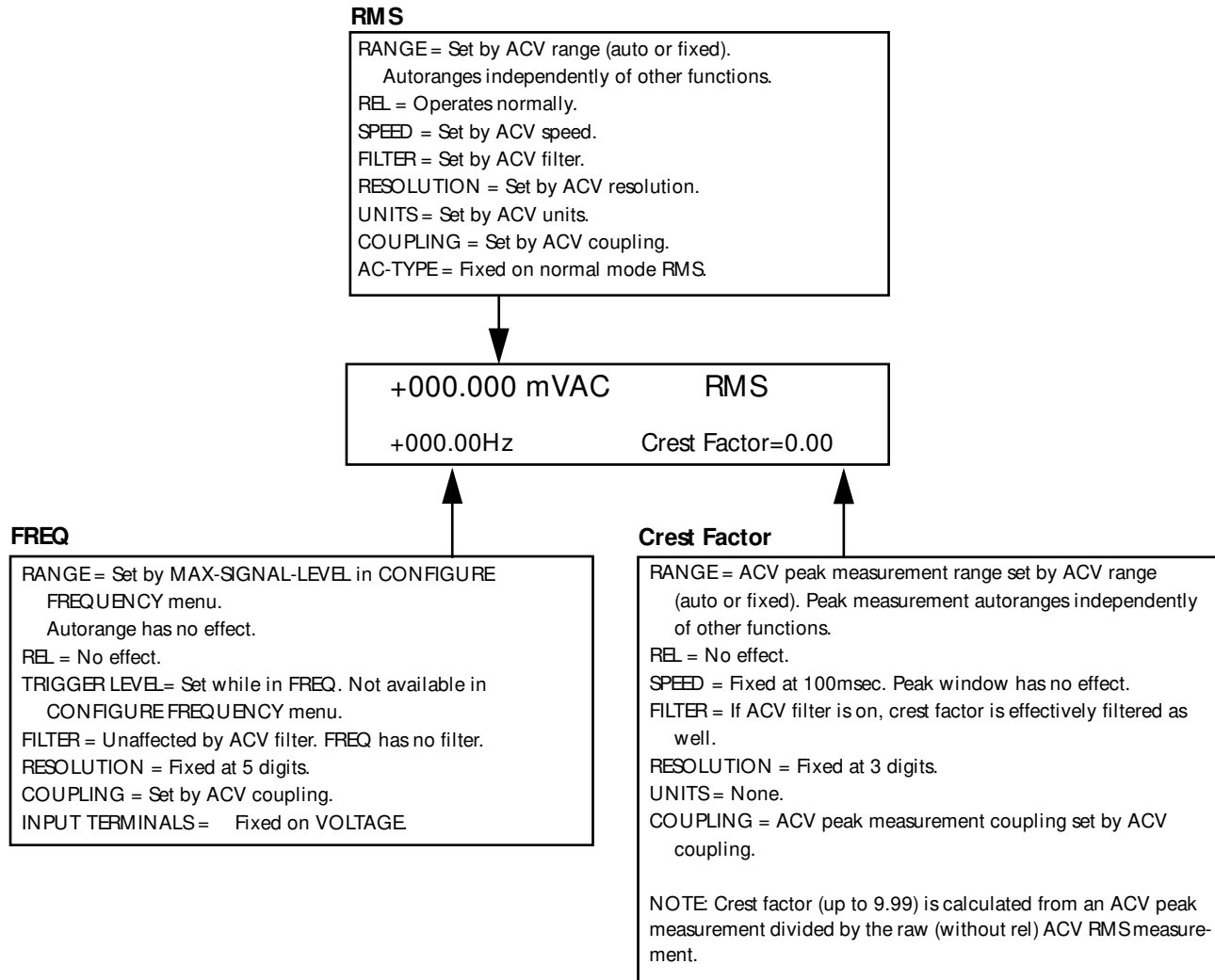

A. AC RMS voltage, frequency, and crest factor

Figure 2-6
 AC voltage multifunction multiple displays

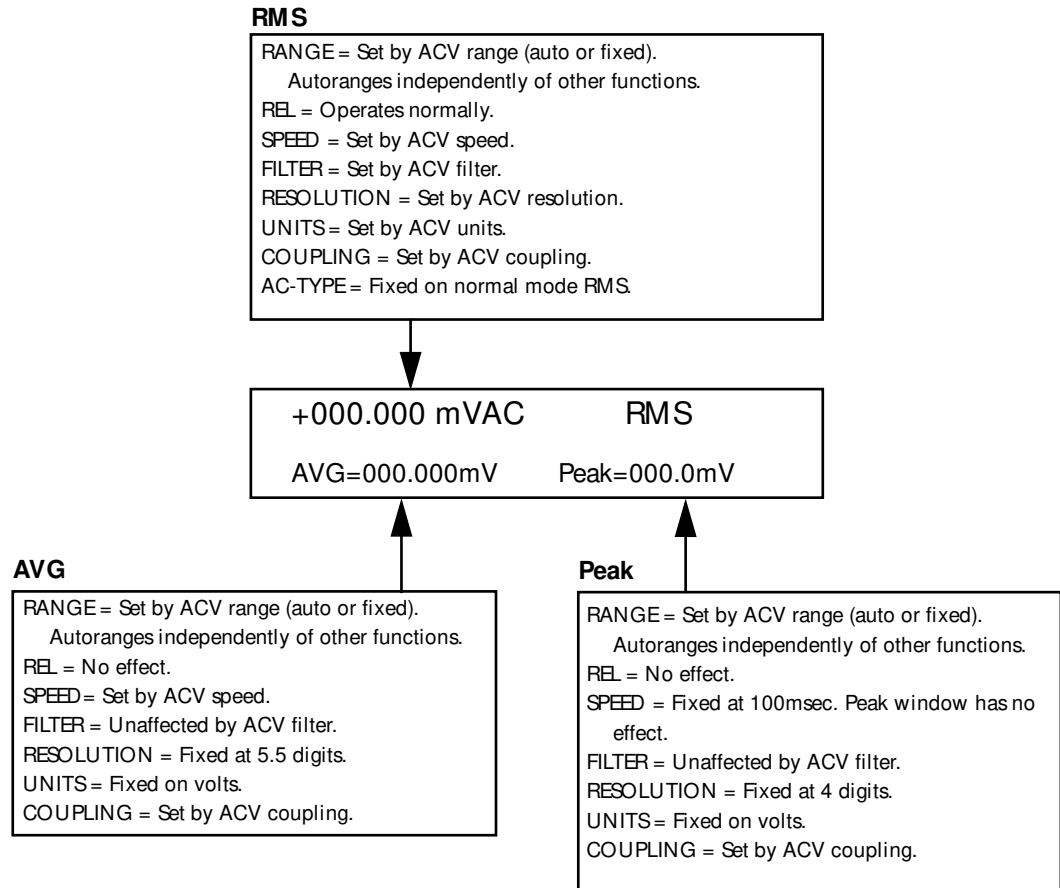

B. AC RMS, average, and peak voltages

Figure 2-6
 AC voltage multifunction multiple displays (cont.)

Crest factor — The crest factor of a waveform is the ratio of its peak value to its RMS value. Thus, the crest factor specifies the dynamic range of a true RMS instrument. For sinusoidal waveforms, the crest factor is 1.414. For a symmetrical square wave, the crest factor is unity. The crest factor of a rectangular pulse is related to its duty cycle; as the duty cycle decreases, the crest factor increases.

For the Model 2002, the additional error term for RMS measurements caused by a high crest factor is specified up to a value of five. The maximum displayable value is 9.99, else it shows “over”.

Note that the crest factor is not calculated if dB or dBm is the presently selected units.

Low level considerations

For sensitive measurements, external considerations besides the Model 2002 affect the accuracy. Effects not noticeable when working with higher voltages are significant in microvolt signals. The Model 2002 reads only the signal received at its input; therefore, it is important that this signal be properly transmitted from the source. The following paragraphs indicate factors that affect accuracy, including thermal offsets and stray pick-up.

Shielding — AC voltages that are extremely large compared with the DC signal to be measured may produce an erroneous output. Therefore, to minimize AC interference, the circuit should be shielded with the shield connected to the Model 2002 INPUT LO (particularly for low-level sources). Improper shielding can cause the Model 2002 to behave in one or more of the following ways:

- Unexpected offset voltages.
- Inconsistent readings between ranges.
- Sudden shifts in reading.

To minimize pick-up, keep the voltage source and the Model 2002 away from strong AC magnetic sources. The voltage induced due to magnetic flux is proportional to the area of the loop formed by the input leads. Therefore, minimize the loop area of the input leads and connect each signal at only one point.

Thermal EMFs — Thermal emfs (thermoelectric potentials) are generated by thermal differences between the junctions of dissimilar metals. These can be large compared to the signal that the Model 2002 can measure. Thermal emfs can cause the following conditions:

- Instability or zero offset is much higher than expected.

- The reading is sensitive to (and responds to) temperature changes. This effect can be demonstrated by touching the circuit, by placing a heat source near the circuit, or by a regular pattern of instability (corresponding to heating and air conditioning systems, or changes in sunlight).

To minimize the drift caused by thermal emfs, use copper leads to connect the circuit to the Model 2002. A banana plug generates a few microvolts. A clean copper conductor such as #10 bus wire is ideal for this application. The leads to the input may be shielded or unshielded, as necessary. Refer to Shielding.

Widely varying temperatures within the circuit can also create thermal emfs. Therefore, maintain constant offset temperatures to minimize these thermal emfs. A cardboard box around the circuit under test also helps by minimizing air currents.

The REL control can be used to null out constant offset voltages.

Note that additional thermals may be generated by the optional Model 2002-SCAN scanner card.

AC voltage offset — The Model 2002, at 5 d resolution, will typically display 150 counts of offset on AC volts with the input shorted. This offset is caused by the offset of the TRMS converter. This offset will not affect reading accuracy and should not be zeroed out using the rel feature. The following equation expresses how this offset (V_{OFFSET}) is added to the signal input (V_{IN}):

$$\text{Displayed reading} = \sqrt{(V_{\text{IN}})^2 + (V_{\text{OFFSET}})^2}$$

Example: Range = 2VAC

Offset = 150 counts (1.5mV)

Input = 200mV RMS

$$\begin{aligned} \text{Display reading} &= \sqrt{(200\text{mV})^2 + (1.5\text{mV})^2} \\ &= \sqrt{0.04\text{V} + (2.25 \times 10^{-6}\text{V})} \\ &= .200005\text{V} \end{aligned}$$

The offset is seen as the last digit which is not displayed. Therefore, the offset is negligible. If the rel feature were used to zero the display, the 150 counts of offset would be subtracted from V_{IN} resulting in an error of 150 counts in the displayed reading.

2.4.2 DC and AC current

The Model 2002 can make normal DCI measurements from 10pA and 2.1A and ACI measurements from 100pA to 2.1A. The basic measurement procedures for DCI and ACI are contained in the Getting Started manual.

AMPS fuse replacement

There are two protection fuses for the current ranges, one for the front terminals, another for the rear. This procedure describes how to change an AMPS fuse.

WARNING

Make sure the instrument is disconnected from the power line and other equipment before replacing an AMPS fuse.

1. Turn off the power and disconnect the power line and test leads.
2. Perform one of the following steps:
 - A. For the front panel AMPS fuse, gently push in the AMPS jack with your thumb and rotate the fuse carrier one-quarter turn counter-clockwise. Release pressure on the jack and its internal spring will push the jack out of the socket.
 - B. For the rear panel AMPS fuse, place the end of a flat-blade screwdriver into the rear panel AMPS holder. Push in gently and rotate the fuse carrier one-quarter turn counter-clockwise. Release pressure on the holder and its internal spring will push the fuse carrier out of the holder.

3. Remove the fuse and replace it with the same type (2A, 250V, fast blow, 5 × 20mm). The Keithley part number is FU-48.

CAUTION

Do not use a fuse with a higher current rating than specified, or instrument damage may occur. If the instrument repeatedly blows fuses, locate and correct the cause of the trouble before replacing the fuse. See the optional Model 2002 Repair Manual for troubleshooting information.

4. Install the new fuse by reversing the above procedure.

Current configuration

The following information explains the various configuration options for DC and AC current measurements. The configuration menus are summarized in Tables 2-11 and 2-12. The menus are accessed by pressing CONFIG and then DCI or ACI. Paragraph 2.3.5 summarizes the rules for navigating through the menus.

Note that a function does not have to be selected in order to be configured. When the function is selected, it will assume the programmed status.

Table 2-11
CONFIGURE DCI menu structure

Menu item	Description
SPEED NORMAL FAST MEDIUM HIACCURACY SET-SPEED-EXACTLY SET-BY-RSLN	Measurement speed (integration time) menu: Select 1 PLC (power line cycle, 16.67msec for 60Hz, 20msec for 50Hz and 400Hz). Select 0.01 PLC. Select 0.1 PLC. Select 10 PLC. Set integration time in PLC (0.01-50). Default to setting appropriate for resolution.
FILTER AUTO AVERAGING ADVANCED AVERAGING-MODE	Digital filter menu: Default to filter appropriate for integration time. Program a simple average filter (1-100 readings). Program a simple average filter (1-100 readings) with a noise tolerance window (0-100% of range). Select moving average or repeating average mode.
RESOLUTION AUTO 3.5d, 4.5d, 5.5d, 6.5d, 7.5d, 8.5d	Display resolution menu: Default to resolution appropriate for integration time. Select a specific resolution.
MEASUREMENT-MODE NORMAL IN-CIRCUIT	Measurement mode menu: Select normal current measurement (use AMPS terminals). Select in-circuit current measurement (use INPUT and SENSE terminals).

Table 2-12
CONFIGURE ACI menu structure

Menu item	Description
SPEED NORMAL FAST MEDIUM HIACCURACY SET-SPEED-EXACTLY SET-BY-RSLN	Measurement speed (integration time) menu: Select 1 PLC (power line cycle, 16.67msec for 60Hz, 20msec for 50Hz and 400Hz). Select 0.01 PLC. Select 0.1 PLC. Select 10 PLC. Set integration time in PLC (0.01-50). Default to setting appropriate for resolution.
FILTER AUTO AVERAGING ADVANCED AVERAGING-MODE	Digital filter menu: Default to filter appropriate for integration time. Program a simple average filter (1-100 readings). Program a simple average filter (1-100 readings) with a noise tolerance window (0-100% of range). Select moving average or repeating average mode.
RESOLUTION AUTO 3.5d, 4.5d, 5.5d, 6.5d, 7.5d, 8.5d	Display resolution menu: Default to resolution appropriate for integration time. Select a specific resolution.
COUPLING AC AC+DC	Coupling menu: Select AC coupled measurements. Select DC coupled measurements.
AC-TYPE RMS AVERAGE	Type of ACI measurement menu: Select true RMS ACI. Select average ACI.

SPEED

The SPEED parameter sets the integration time of the A/D converter, the period of time the input signal is measured (also known as aperture). It is discussed in paragraph 2.4.1, DC and AC voltage. Only the differences for DC and AC current are noted here.

SET-BY-RSLN: This parameter optimizes the integration time for the present resolution setting. The defaults for set-by-resolution integration times of DCI and ACI are listed in Table 2-13.

Table 2-13
DCI and ACI integration time set-by-resolution

Measurement function and type	Resolution	Integration time
DC current	3.5d, 4.5d	0.01 PLC
	5.5d	0.02 PLC
	6.5d	0.20 PLC
	7.5d, 8.5d	2.00 PLC
DC in-circuit current	3.5d to 7.5d	Not used
RMS, average	3.5d, 4.5d	0.01 PLC
	5.5d	0.02 PLC
	6.5d, 7.5d, 8.5d	10.00 PLC

Notes:

1. For normal DC current, if the integration time is SET-BY-RSLN and the resolution is AUTO, the integration time will be 1.0 PLC and the resolution 6.5 digits.
2. For DC in-circuit current, the integration time setting is ignored.
3. For AC current, if the integration time is SET-BY-RSLN and the resolution is AUTO, the integration time will be 1.0 PLC and the resolution 5.5 digits.

Table 2-14
DCI and ACI auto filter

Measurement function and type	State	Type	Readings	Noise tolerance	Mode
DC current	On	Advanced	10	1.0%	Moving
DC in-circuit current	On	Advanced	10	1.0%	Moving
AC current	Off	Advanced	10	5.0%	Moving

FILTER

FILTER lets you set the digital filter response. The filter menu is available from the function configuration menus (i.e. CONFIGURE DCI) or by pressing CONFIGURE FILTER with the desired function already selected. All of the parameters (menu items) for FILTER are explained in paragraph 2.9. Since the AUTO parameter has specific effects on DCI and ACI, it is covered here.

AUTO: This parameter for a digital filter optimizes its use for the present measurement function. The defaults for automatic filtering of DCI and ACI are listed in Table 2-14.

RESOLUTION

The RESOLUTION parameter sets the display resolution. It is discussed in paragraph 2.4.1, DC and AC voltage. Only the differences for DC and AC current are noted here.

AUTO: Refer to Table 2-15 for the resolution associated with the integration time.

MEASUREMENT-MODE

This option selects the DC current measurement mode, either normal or in-circuit measurements.

NORMAL: This option is for normal current measuring, where the meter is placed in series with the current path and the voltage across an internal shunt resistor is measured.

Table 2-15
DCI and ACI auto resolution

Measurement function and type	Integration time	Resolution
DC current	0.01 to <0.02 PLC	4.5d
	0.02 to <0.20 PLC	5.5d
	0.20 to <2.00 PLC	6.5d
	2.00 to 50 PLC	7.5d
DC in-circuit current	Not used	5.5d
RMS, average	0.01 to <0.02 PLC	4.5d
	0.02 to <10.00 PLC	5.5d
	10.00 to 50 PLC	6.5d

Notes:

- For normal DC current, if the resolution is AUTO and the integration time is SET-BY-RSLN, the resolution will be 6.5 digits and the integration time 1.0 PLC.
- For DC in-circuit current, the integration time setting is ignored.
- For AC current, if the resolution is AUTO and the integration time is SET-BY-RSLN, the resolution will be 5.5 digits and the integration time 1.0 PLC.

IN-CIRCUIT: In-circuit current is a calculation based on a 4-wire resistance measurement and a voltage measurement. It is similar to an offset-compensated ohms measurement.

The current in a low resistance conductor (e.g., a printed circuit trace) can be measured without breaking the current path. The Model 2002 can do this with a pair of Kelvin test probes across the conductor. See Figure 2-7. The method follows:

- Using one set of the Kelvin probe tips, the instrument sources a known current (I_{SOURCE}) through the conductor and simultaneously measures the resulting voltage (V_{MEAS1}) with the other set of probe tips:

$$V_{MEAS1} = (I_{IN-CKT} + I_{SOURCE})R_{TRACE}$$

or

$$R_{TRACE} = \frac{V_{MEAS1}}{(I_{IN-CKT} + I_{SOURCE})}$$

- The instrument then measures the voltage (V_{MEAS2}) across the conductor without sourcing an additional current:

$$V_{MEAS2} = (I_{IN-CKT})R_{TRACE}$$

or

$$R_{TRACE} = \frac{V_{MEAS2}}{(I_{IN-CKT})}$$

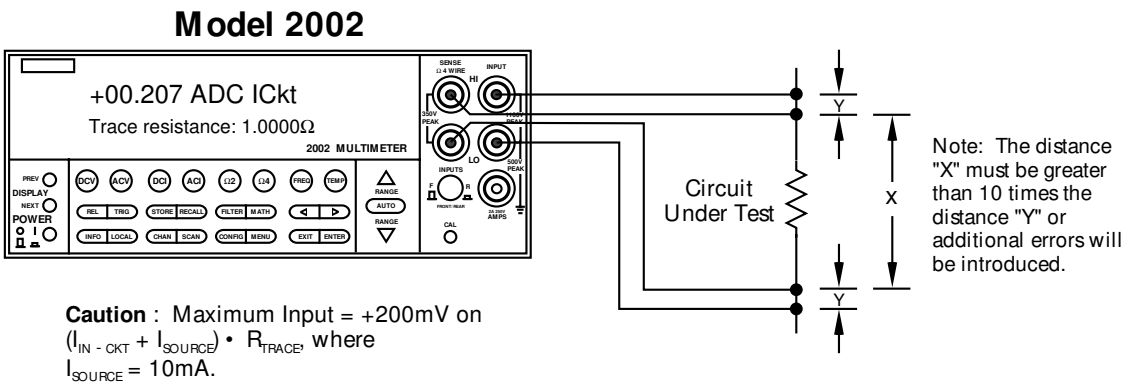

Figure 2-7
DC in-circuit current measurements

3. It then calculates the in-circuit current by combining the equations and solving for I_{IN-CKT} :

$$\frac{V_{MEAS1}}{(I_{IN-CKT} + I_{SOURCE})} = \frac{V_{MEAS2}}{(I_{IN-CKT})}$$

$$V_{MEAS1}(I_{IN-CKT}) = V_{MEAS2}(I_{IN-CKT} + I_{SOURCE})$$

$$V_{MEAS1}(I_{IN-CKT}) = V_{MEAS2}(I_{IN-CKT}) + V_{MEAS2}(I_{SOURCE})$$

$$V_{MEAS1}(I_{IN-CKT}) - V_{MEAS2}(I_{IN-CKT}) = V_{MEAS2}(I_{SOURCE})$$

$$I_{IN-CKT}(V_{MEAS1} - V_{MEAS2}) = V_{MEAS2}(I_{SOURCE})$$

$$I_{IN-CKT} = \frac{V_{MEAS2}(I_{SOURCE})}{(V_{MEAS1} - V_{MEAS2})}$$

Because of accuracy considerations, in-circuit current readings are limited to traces with a resistance of $1m\Omega$ to 10Ω . If either of these limits is exceeded in the resistance calculation, the in-circuit current cannot be calculated. The bottom line of the front panel display will show and update the trace resistance.

A procedure to measure in-circuit current follows:

1. Select the in-circuit current measurement mode from the CONFIGURE DCI menu and place the instrument in the DCI function. Note that the 4W annunciator lights to indicate this is a 4-wire measurement.
2. Connect a set of Kelvin test probes, such as Keithley Model 5805 or 5806, to the Model 2002 INPUT HI and LO terminals and SENSE HI and LO terminals.
3. For $R_{TRACE} < 50m\Omega$, or where the conductors are physically hot, rel out (zero correct) any thermal offsets that are present before measuring in-circuit current. With power to the test circuit removed, place the probes on the desired trace and enable rel from the DCI function.
4. Turn on the power to the test circuit and read the in-circuit current calculation. The speed of this measurement is four readings per second at 1PLC. Its range is fixed at 12A. The default filter for in-circuit current is a moving average of ten readings. Additional filtering may be needed at low current levels.

A measurement overflow occurs for any of the following conditions:

- The measured voltage exceeds $|\pm 200mV|$.
- The trace resistance is less than $1m\Omega$ or greater than 10Ω .
- The in-circuit current is greater than 12A.

COUPLING

This parameter selects the input coupling for the ACI function.

AC: With AC coupling selected, a DC block capacitor is placed in series with the AC measurement circuit (note that the current shunt resistors are always DC coupled to the inputs. This removes the DC component from the RMS and average ACI measurement.

AC+DC: When AC+DC coupling is selected, the blocking capacitor is removed. Subsequent RMS or average ACI measurements reflect both the AC and DC components of the signal.

Note that the coupling settings for ACI and ACV are discrete. Thus, setting the coupling of ACI has no effect on the coupling of ACV.

AC-TYPE

This parameter selects the measurement type for the ACI function. The Model 2002 directly measures RMS and average AC current.

RMS: With this parameter selected, the instrument performs RMS AC current measurements.

AVERAGE: When this item is selected, the signal path in the instrument bypasses the RMS converter, and the average ACI measurement is the filtered output of a full wave rectifier.

Multiple displays

The multiple displays for AC current that show multiple functions are shown in Figure 2-8. There are no multifunction displays for DC current.

RMS (or AVG)

RANGE = Set by ACI range (auto or fixed).
 Autoranges independently of other function.
 REL = Operates normally.
 SPEED = Set by ACI speed.
 FILTER = Set by ACI filter.
 RESOLUTION = Set by ACI resolution.
 COUPLING = Set by ACI coupling.
 AC-TYPE = Set by ACI AC-Type.

+000.000 μ AAC RMS (or AVG)
 +0.0000 Hz

FREQ

RANGE = Set by MAX-SIGNAL-LEVEL in CONFIGURE FREQUENCY menu.
 Autorange has no effect.
 REL = No effect.
 TRIGGER LEVEL = Set while in FREQ. Not available in CONFIGURE FREQUENCY menu.
 FILTER = Unaffected by ACI filter. FREQ has no filter.
 RESOLUTION = Fixed at 5 digits.
 COUPLING = Set by ACI coupling.
 INPUT TERMINALS = Fixed on CURRENT

A. AC RMS (or average) current and frequency functions

RMS

RANGE = Set by ACI range (auto or fixed).
 Autoranges independently of other function.
 REL = Operates normally.
 SPEED = Set by ACI speed.
 FILTER = Set by ACI filter.
 RESOLUTION = Set by ACI resolution.
 COUPLING = Set by ACI coupling.

+000.000 μ AAC RMS
 AVG=000.000 μ AAC

AVG

RANGE = Set by ACI range (auto or fixed).
 Autoranges independently of other function.
 REL = No effect.
 SPEED = Set by ACI speed.
 FILTER = Unaffected by ACI filter.
 RESOLUTION = Fixed at 5.5 digits.
 COUPLING = Set by ACI coupling.

B. AC RMS and average current functions

Figure 2-8
 AC current multifunction multiple displays

2.4.3 Two and four-wire resistance

The Model 2002 can make 2-wire resistance measurements from 100n Ω to 1.05G Ω and 4-wire resistance measurements from 100n Ω to 2.1M Ω . The basic measurement procedures for Ω 2 and Ω 4 are contained in the Getting Started manual.

Shielding

It helps to shield resistance greater than 100k Ω to achieve a stable reading. Place the resistance in a shielded enclosure and electrically connect the shield to the INPUT LO terminal of the instrument.

Resistance configuration

The following information explains the various configuration options for 2-wire and 4-wire resistance measurements. The configuration menus are summarized in Tables 2-16 and 2-17. The menus are accessed by pressing CONFIG and then Ω 2 or Ω 4. Paragraph 2.3.5 summarizes the rules for navigating through the menus.

Note that a function does not have to be selected in order to be configured. When the function is selected, it will assume the programmed status.

Table 2-16
CONFIGURE OHMS-2W menu structure

Menu item	Description
SPEED NORMAL FAST MEDIUM HIACCURACY SET-SPEED-EXACTLY SET-BY-RSLN	Measurement speed (integration time) menu: Select 1 PLC (power line cycle, 16.67msec for 60Hz, 20msec for 50Hz and 400Hz). Select 0.01 PLC. Select 0.1 PLC. Select 10 PLC. Set integration time in PLC (0.01-50). Default to setting appropriate for resolution.
FILTER AUTO AVERAGING ADVANCED AVERAGING-MODE	Digital filter menu: Default to filter appropriate for integration time. Program a simple average filter (1-100 readings). Program a simple average filter (1-100 readings) with a noise tolerance window (0-100% of range). Select moving average or repeating average mode.
RESOLUTION AUTO 3.5d, 4.5d, 5.5d, 6.5d, 7.5d, 8.5d	Display resolution menu: Default to resolution appropriate for integration time. Select a specific resolution.
OFFSETCOMP	Enable/disable offset compensation (20 Ω -20k Ω ranges).
MAXAUTORANGE 1G Ω , 200M Ω , 20M Ω , 2M Ω , 200k Ω , 20k Ω	Set upper limit for autoranging of 2-wire resistance. Select a specific range.

Table 2-17
CONFIGURE OHMS-4W menu structure

Menu item	Description
SPEED NORMAL FAST MEDIUM HIACCURACY SET-SPEED-EXACTLY SET-BY-RSLN	Measurement speed (integration time) menu: Select 1 PLC (power line cycle, 16.67msec for 60Hz, 20msec for 50Hz and 400Hz). Select 0.01 PLC. Select 0.1 PLC. Select 10 PLC. Set integration time in PLC (0.01-50). Default to setting appropriate for resolution.
FILTER AUTO AVERAGING ADVANCED AVERAGING-MODE	Digital filter menu: Default to filter appropriate for integration time. Program a simple average filter (1-100 readings). Program a simple average filter (1-100 readings) with a noise tolerance window (0-100% of range). Select moving average or repeating average mode.
RESOLUTION AUTO 3.5d, 4.5d, 5.5d, 6.5d, 7.5d, 8.5d	Display resolution menu: Default to resolution appropriate for integration time. Select a specific resolution.
OFFSETCOMP	Enable/disable offset compensation (20 Ω -20k Ω ranges).
MAXAUTORANGE 2M Ω , 200k Ω , 20k Ω , 2k Ω , 200 Ω , 20 Ω	Set upper limit for autoranging of 4-wire resistance. Select a specific range.

SPEED

The SPEED parameter sets the integration time of the A/D converter, the period of time the input signal is measured (also known as aperture). It is discussed in paragraph 2.4.1, DC and AC voltage. Only the differences for 2-wire and 4-wire resistance are noted here.

SET-BY-RSLN: This parameter optimizes the integration time for the present resolution setting. The defaults for set-by-resolution integration times of $\Omega 2$ and $\Omega 4$ are listed in Table 2-18.

Table 2-18
 $\Omega 2$ and $\Omega 4$ integration time set-by-resolution

Resolution	Integration time
3.5d, 4.5d	0.01 PLC
5.5d	0.02 PLC
6.5d	0.10 PLC
7.5d	1.00 PLC
8.5d	10.00 PLC

Note: If the integration time is SET-BY-RSLN and the resolution AUTO, the integration time will be 1.0 PLC and the resolution 7.5 digits.

FILTER

FILTER lets you set the digital filter response. The filter menu is available from the function configuration menus (i.e. CONFIGURE OHMS-2W) or by pressing CONFIGURE FILTER with the desired function already selected. All of the parameters (menu items) for FILTER are explained in paragraph 2.9. Since the AUTO parameter has specific effects on $\Omega 2$ and $\Omega 4$, it is covered here.

AUTO: This parameter for a digital filter optimizes its use for the present measurement function. The defaults for automatic filtering of $\Omega 2$ and $\Omega 4$ are listed in Table 2-19.

RESOLUTION

The RESOLUTION parameter sets the display resolution. It is discussed in paragraph 2.4.1, DC and AC voltage. Only the differences for $\Omega 2$ and $\Omega 4$ are noted here.

Note that all scientific notation displays are 7-1/2 digits. Labels on the far right, such as channel number, may be omitted to provide the desired precision.

Table 2-19
 $\Omega 2$ and $\Omega 4$ auto filter

Measurement function	State	Type	Rdg.	Noise tolerance	Avg. Mode
2-wire resistance	On	Advanced	10	1.0%	Moving
4-wire resistance	On	Advanced	10	1.0%	Moving

AUTO: Refer to Table 2-20 for the resolution associated with the integration time.

Table 2-20
 $\Omega 2$ and $\Omega 4$ auto resolution

Integration time	Resolution
0.01 to <0.02 PLC	4.5d
0.02 to <0.10 PLC	5.5d
0.10 to <1.00 PLC	6.5d
1.00 to <10.00 PLC	7.5d
10.00 to 50 PLC	8.5d

Note: If the resolution is AUTO and the integration time SET-BY-RSLN, the resolution will be 7.5 digits and the integration time 1.0 PLC.

OFFSETCOMP

Offset compensation is used to compensate for voltage potentials, such as thermal offsets, across the device under test. This feature eliminates errors due to a low level external voltage source configured in series with the unknown resistor. Offsets up to $\pm 0.2V$ on the 20Ω and 200Ω ranges, and from $-0.2V$ to $+2V$ on the $2k\Omega$ and $20k\Omega$ ranges can be corrected with offset compensation. Offset compensation is available for 2- and 4-wire resistance measurements.

During offset compensated resistance measurements, the Model 2002 performs the following steps for each A/D conversion:

1. Makes a normal resistance measurement of the device. In general, this consists of sourcing a current through the device, and measuring the voltage drop across the device.
2. Turns off the internal current source and again measures the voltage drop across the device. This is the voltage caused by an external device.
3. Calculates and displays the corrected resistance value.

Offset compensation not only corrects for small error voltages in the measurement circuit, but it also compensates for thermal voltages generated within the Model 2002. Consequently, the use of offset compensation yields greater accuracy.

The OFFSETCOMP selections are explained as follows:

ON: Enables offset compensation

OFF: Disables offset compensation

Offset compensated readings are indicated by “OCmp” to the right of the reading.

Note that the offset compensation settings of the ohms functions are discrete. Thus, enabling offset compensation in 2-wire ohms has no effect on 4-wire ohms.

MAXAUTORANGE

By setting an upper limit on autoranging, you can prevent changes to ranges that you do not want to use. This speeds up the reading rate while still using auto-ranging.

MAXAUTORANGE selections for $\Omega 2$ and $\Omega 4$:

1G Ω , 200M Ω , 20M Ω , 2M Ω , 200k Ω or 20k Ω : Sets maximum autorange limit for $\Omega 2$.

2M Ω , 200k Ω , 20k Ω , 2k Ω , 200 Ω or 20 Ω : Sets maximum autorange limit for $\Omega 4$.

Multiple displays

There are three multiple displays available just for the resistance functions:

- Source current
- Voltage drop
- Lead resistance ($\Omega 4$ only)

Source current: This is the value of the current being sourced for the present resistance range. It is based on the calibration constants and is shown as follows:

$$\text{Source Current} = 0.0000 \text{ mA}$$

Voltage drop: This display shows the voltage drop across the resistance under test. It is shown as follows:

$$\text{Voltage Drop} = 0.0000 \text{ mV}$$

This voltage drop is determined by multiplying the source current by the resistance and does not include voltage contributions from other current that may be flowing through the resistance.

Lead Resistance: This display, available only for 4-wire ohms, shows the value of the lead resistance that is being nulled by using the $\Omega 4$ function. You can use the information to decide if a 4-wire measurement is necessary. The display is as follows:

$$\text{Lead Resistance} = 0.0000 \Omega$$

If the lead resistance exceeds $1k\Omega$, the display is:

2-WIRE OHMS measurement overflow

2.4.4 Frequency

The Model 2002 can make frequency measurements from 1Hz to 15MHz through its INPUT HI and INPUT LO terminals, and from 1Hz to 1MHz through its AMPS and INPUT LO terminals. The basic measurement procedure for FREQ is contained in the Getting Started manual.

Trigger level

The frequency function has an adjustable trigger level. An appropriate trigger level is needed for the frequency counter to operate properly. The instrument only counts cycles with peak amplitudes that reach the trigger level. For example, if the trigger level is set for 5V, cycles with peak amplitudes less than 5V are not counted.

If using AC+DC coupling, make sure the trigger level accounts for the DC bias level. For example, if a 1V peak-to-peak input signal is riding on a 5V DC bias level, a trigger level of 5.5V is appropriate.

While the display is showing frequency measurements, the RANGE ▲ and ▼ keys can be used to change the trigger level of the measurement.

Each press of a RANGE ▲ or ▼ key adjusts the trigger level by 0.5% of the presently selected maximum signal level to a maximum of 60% of the range. The AUTO RANGE key returns the trigger level to 0V or 0mA. After pressing one of the range keys, the present trigger level is momentarily displayed. The trigger level is also available as a multiple display.

See Table 2-21 for the trigger level ranges and increments.

Table 2-21
Trigger level range and increments

Maximum signal level	Trigger level	
	Range	Increment
1V	-0.600 to +0.600V	0.005V
10V	-6.00 to +6.00V	0.05V
100V	-60.0 to +60.0V	0.5V
1000V	-600 to +600V	5V
1mA	-0.600mA to +0.600mA	0.005mA
10mA	-6.00mA to +6.00mA	0.05mA
100mA	-60.0mA to +60.0mA	0.5mA
1A	-600mA to +600mA	5mA

Frequency configuration

The following information explains the various configuration options for frequency measurements. The configuration menu is summarized in Table 2-22. This menu is accessed by pressing CONFIG and then FREQ. Paragraph 2.3.5 summarizes the rules for navigating through the menus.

Note that a function does not have to be selected in order to be configured. When the function is selected, it will assume the programmed status.

MAX-SIGNAL-LEVEL

The maximum signal level is used to specify the maximum expected peak input voltage or current level for frequency measurements.

The following MAX-SIGNAL-LEVEL selections depend on which input terminals are presently selected (see INPUT-TERMINALS):

1V, 10V, 100V, 1000V or TTL: Sets the maximum signal level for the voltage input terminals. Selecting the TTL parameter configures the maximum signal level to 10V and the trigger level to +0.8V.

1mA, 10mA, 100mA or 1A: Sets the maximum signal level for the AMPS input terminals.

The MAX-SIGNAL-LEVEL setting is critical to the accuracy of frequency measurements. If the selected level is too large, the input signal is not large enough to trigger the instrument's zero-crossing circuitry, and a 0mHz reading results.

To verify the proper level, use the AC voltage or AC current function to measure the rms value of the input signal. The resultant reading indicates the best level to use. For example, if the rms value is 2V, a maximum signal level setting of 10V is appropriate. Note that the coupling used in the AC measurement should match that used in the frequency measurement.

RESOLUTION

The available display resolutions are 4 digits and 5 digits. There is no auto resolution parameter on the frequency function.

4-DIGITS: Sets display resolution for frequency measurements to 4-digits.

5-DIGITS: Sets display resolution for frequency measurements to 5-digits.

Table 2-22
CONFIGURE FREQUENCY menu structure

Menu item	Description
MAX-SIGNAL-LEVEL 1V, 10V, 100V, 1000V, TTL 1mA, 10mA, 100mA, 1A	Display maximum signal level menu: Select maximum voltage level for voltage inputs. Select maximum current level for current inputs.
RESOLUTION 4-DIGITS, 5-DIGITS	Display resolution menu: Select a specific resolution.
INPUT-TERMINALS VOLTAGE CURRENT	Input terminals for frequency measurements menu: Select INPUT HI and INPUT LO terminals. Select AMPS and INPUT LO terminals.
COUPLING AC AC+DC	Coupling menu: Select AC coupled measurements. Select DC coupled measurements.

Notes:

1. The maximum signal level menu is coupled to the input terminals menu, i.e., voltage levels are shown if voltage is the selected input.
2. With the Model 1801 Nanovolt Preamp installed and enabled, the maximum signal level is fixed at 2mV.

INPUT-TERMINALS

Both the volts and amps input terminals can be used to measure frequency. The upper limit on the voltage terminals is 15MHz; on the amps terminals it is 1MHz. The voltage limit is subject to the $2 \times 10^7 \text{V} \cdot \text{Hz}$ product.

VOLTAGE: Specifies the voltage input terminals for frequency measurements.

CURRENT: Specifies the AMPS input terminals for frequency measurements.

COUPLING

This parameter selects the input coupling for the frequency function.

AC: With AC coupling selected, a DC blocking capacitor is placed in series with the AC measurement circuit. This removes the DC component from the input signal.

AC+DC: When AC+DC coupling is selected, the blocking capacitor is removed. Subsequent FREQ measurements reflect both the AC and DC components of the signal.

Multiple displays

There are two multiple displays just for the frequency function:

- Period calculation
- Trigger level

The multiple display showing the period of the waveform is calculated from the frequency measurement and, as such, is only available when the frequency does not equal 0Hz. It is also unavailable when math is enabled.

The trigger level multiple display is the same message that is displayed when the trigger level is changed, but it is a permanent display.

2.4.5 Temperature

The Model 2002 measures temperature with two different sensor types: RTDs and thermocouples. With RTDs, the Model 2002 can measure temperature between -200°C and +630°C. RTDs can be connected to the input terminals or the optional Model 2001-SCAN scanner card.

When using thermocouples, the instrument measures temperature over a range that is dependent on the thermocouple type (refer to the specifications in Appendix A). Thermocouples can be connected to the Model 2001-TCSCAN card (which plugs into the option slot of the Model 2002), or to an external thermocouple card, such as a Model 7057A or 7402 installed in a Model 7001 or 7002 Switch System.

Temperature measurements

The basic measurement procedure for 4-wire RTD temperature measurements is contained in the Getting Started manual. The procedure for measuring temperature with 3-wire and 2-wire RTDs is similar. Connection diagrams for these RTDs are provided by Figures 2-9 and 2-10. Be sure that the temperature function is configured for the correct sensor type. Use the 4-WIRE-RTD selection for a 3-wire RTD sensor.

If using the Model 2001-TCSCAN to make thermocouple temperature measurements, refer to its instruction manual for connection information and the measurement procedure. If using the Model 7057A or 7402, connect the output of the thermocouple card to INPUT HI and LO of the Model 2002 and refer to its instruction manual for operating information.

The Models 7057A and 7402 use Channel 1 as the reference junction, and must be configured on the Model 2002 for voltage references and offset.

Temperature configuration

The following information explains the various configuration options for temperature measurements. The configuration menu is summarized in Table 2-23. This menu is accessed by pressing CONFIG and then TEMP. Paragraph 2.3.5 summarizes the rules for navigating through the menus.

Note that a function does not have to be selected in order to be configured. When the function is selected, it will assume the programmed status.

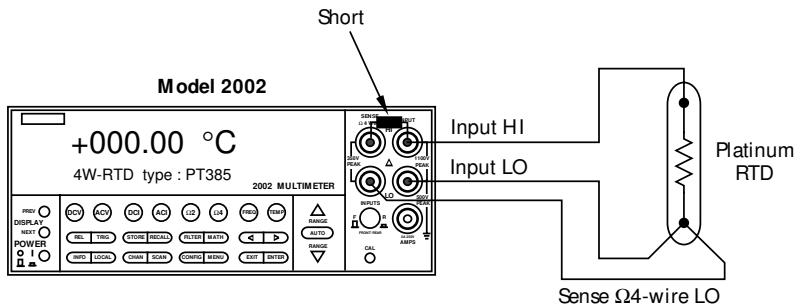

A. Connections to Banana Jacks

WARNING : To avoid a shock hazard and possible instrument damage, do not use the Model 8680 RTD Probe Adapter to measure voltages exceeding 30V RMS, 42.4V peak.

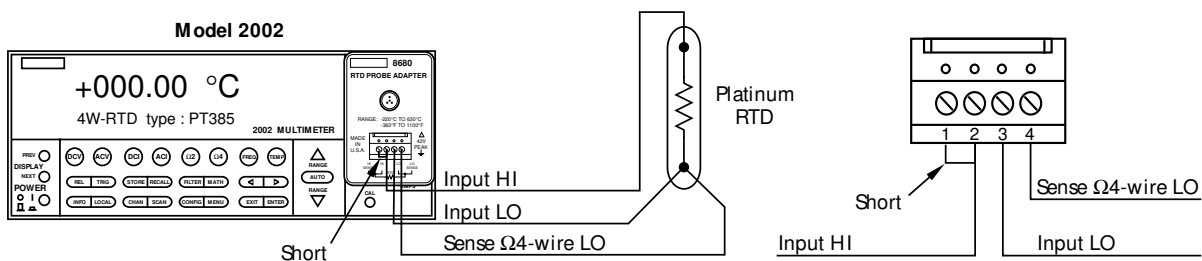

B. Connections to Terminal Block

Figure 2-9
3-wire RTD temperature measurements

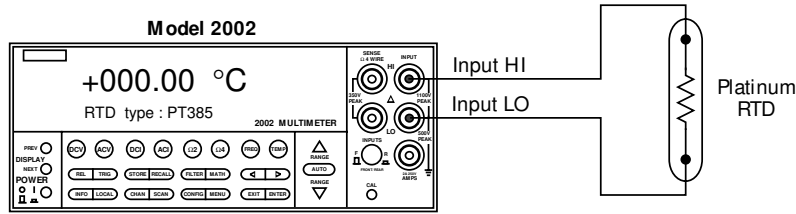

A. Connections to Banana Jacks

WARNING : To avoid a shock hazard and possible instrument damage, do not use the Model 8680 RTD Probe Adapter to measure voltages exceeding 30V RMS, 42.4V peak.

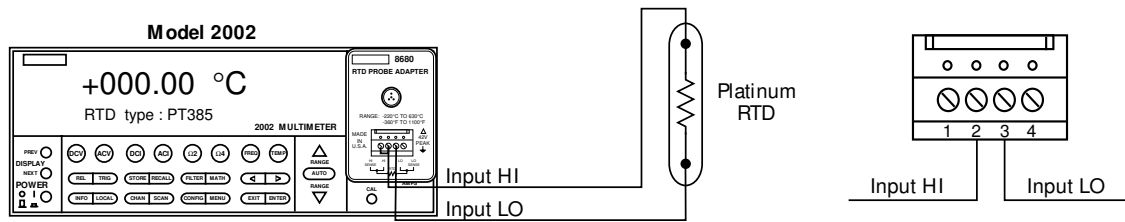

B. Connections to Terminal Block

Figure 2-10
2-wire RTD temperature measurements

Table 2-23
CONFIG TEMPERATURE menu structure

Menu item	Description
<p>SENSOR</p> <p> 4-WIRE-RTD</p> <p> PT100</p> <p> D100</p> <p> F100</p> <p> USER</p> <p> PT385</p> <p> PT3916</p> <p> SPRTD</p> <p> RTD</p> <p> PT100</p> <p> D100</p> <p> F100</p> <p> USER</p> <p> PT385</p> <p> PT3916</p> <p> SPRTD</p> <p> THERMOCOUPLE</p> <p> THERMOCOUPLE-TYPE</p> <p> REF-JUNCTIONS</p> <p> CONFIGURE</p> <p> ACQUIRE-REF-TEMP</p> <p> INTERNAL-TEMP</p> <p>UNITS</p> <p> DEG-C, DEG-F, K</p> <p>SPEED</p> <p> NORMAL</p> <p> FAST</p> <p> MEDIUM</p> <p> HIACCURACY</p> <p> SET-SPEED-EXACTLY</p> <p> SET-BY-RSLN</p> <p>FILTER</p> <p> AUTO</p> <p> AVERAGING</p> <p> AVERAGING-MODE</p> <p>RESLN</p> <p> AUTO</p> <p> 1°, 0.1°, 0.01°, 0.001°</p>	<p>Sensor type menu:</p> <p>4-wire RTD type menu:</p> <p> Select PT100 type.</p> <p> Select D100 type.</p> <p> Select F100 type.</p> <p> Use to set R-zero, alpha, beta, delta.</p> <p> Select PT385 type.</p> <p> Select PT3916 type.</p> <p> Select SPRTD type.</p> <p>2-wire RTD type menu:</p> <p> Select PT100 type.</p> <p> Select D100 type.</p> <p> Select F100 type.</p> <p> Use to set R-zero, alpha, beta, delta.</p> <p> Select PT385 type.</p> <p> Select PT3916 type.</p> <p> Select SPRTD type.</p> <p>Thermocouple setup menu:</p> <p> Select desired thermocouple type (J, K, T, E, R, S, B, N).</p> <p> Configure reference junction menu (JCN1 thru JCN5):</p> <p> Configure simulated or real junction.</p> <p> Acquire reference temperature.</p> <p> Select internal temperature transducer.</p> <p>Temperature units menu:</p> <p> Select desired temperature units.</p> <p>Measurement speed (integration time) menu:</p> <p> Select 1 PLC (power line cycle, 16.67msec for 60Hz, 20msec for 50Hz and 400Hz).</p> <p> Select 0.01 PLC.</p> <p> Select 0.1 PLC.</p> <p> Select 10 PLC.</p> <p> Set integration time in PLC (0.01-50).</p> <p> Default to setting appropriate for resolution.</p> <p>Digital filter menu:</p> <p> Default to filter appropriate for integration time.</p> <p> Select simple average filter (1-100 readings).</p> <p> Select moving average or repeating average mode.</p> <p>Display resolution menu:</p> <p> Default to resolution appropriate for sensor.</p> <p> Select a specific resolution.</p>

Note: With the Model 1801 Nanovolt Preamp installed and enabled, the SENSOR menu item is used for differential thermocouple configuration.

SENSOR

This parameter is used to select the temperature sensor.

4-WIRE-RTD or RTD: If using a 4-wire or 3-wire RTD sensor, select 4-WIRE-RTD. If using a 2-wire RTD, select RTD. Selecting an RTD sensor displays the options for RTD standards. Five are configured for common RTDs and the sixth allows you to enter your own RTD factors:

- PT100, D100, F100, PT385 and PT3916 — Selects the following default parameters for the RTD standards:

Type	Standard	Alpha	Beta	Delta	RZero (Ω at 0°C)
PT100	ITS-90	0.003850	0.10863	1.49990	100.00000
D100	ITS-90	0.003920	0.10630	1.49710	100.00000
F100	ITS-90	0.003900	0.11000	1.49589	100.00000
PT385	IPTS-68	0.003850	0.11100	1.50700	100.00000
PT3916	IPTS-68	0.003916	0.11600	1.50594	100.00000

- USER — This selection allows you to change one or more of the RTD factors listed in the above table. The equation using the factors are shown in Figure 2-11.

SPRTD: Choosing type SPRTD takes you to the SPRTD COEFFICIENTS menu, which allows you to program the following parameters:

R-ZERO: RTD 0°C resistance value

A4: set A4 coefficient

B4: set B4 coefficient

A7: set A7 coefficient

B7: set B7 coefficient

C7: set C7 coefficient

The ITS-90 standard provides two reference equations for Standard Platinum Resistance Thermometers covering the temperature range 18.8033K to 1234.93K. A single SPRTD, however, usually cannot be used to cover the entire range. The temperature range is therefore broken up into several subranges. These subranges depend on the calibration points of the temperature scale and are based on the melting or triple points of various pure substances. For an exact list of the elements needed and details on RTD calibration, refer to NIST Technical Note 1265 "Guidelines For Realizing the International Temperature Scale of 1990". In each subrange, the calibration constants required for that range are listed.

An SPRTD as supplied from the manufacturer will come with a certificate of calibration that lists the calibration constants and the temperature range supported. In all cases except subranges #4 and #7, translation of the supplied coefficients to Model 2002 values will be required. In most cases, this translation is done simply entering the A value (for example) supplied with the SPRTD into the A4 position (temperatures less than 0°C) or A7 value (temperatures above 0°C) required by the Model 2002. The same procedure is used for translating the B and, where applicable, C constants.

The following table should be helpful in translating SPRTD coefficients to Model 2002 SPRTD coefficients. The Model 2002 supports SPRTD temperatures between 83.805K and 933.473K. For any of the subranges below, only temperatures within the range from 83.805K to 933.47K will be measured.

Coefficients	RTD coefficients to Model 2002 coefficients
Subrange #1: 13.8033K - 273.16K	Not applicable
Subrange #2: 24.5561K - 273.16K	A2 to A4, B2 to B4
Subrange #3: 54.3584K - 273.16K	A3 to A4, B3 to B4
Subrange #4: 83.8058K - 273.16K	No substitution needed
Subrange #5: 234.3156K - 302.9146K	A5 to A4, A5 to A7, B5 to B4 B5 to B7, Set C7 = 0. A5 value entered for both A4 and A7; B5 value entered for both B4 and B7
Subrange #6: 273.15K - 1234.93K	Not applicable
Subrange #7: 273.15K - 933.473K	No substitution needed
Subrange #8: 273.15K - 692.677K	A8 to A7, B8 to B7, Set C7 = 0
Subrange #9: 273.15K - 505.078K	A9 to A7, B9 to B7, Set C7 = 0
Subrange #10: 273.15K - 429.7485K	A10 to A7, B10 to B7, Set C7 = 0
Subrange #11: 273.15K - 302.9146K	A11 to A7, Set B7 = 0, C7 = 0

Measurement Example: Suppose you are using an SPRTD that has been calibrated for subrange #2 above, in which case the RTD is calibrated for measurements between 24.5561 and 273.16K. The Model 2002, however, supports only SPRTD temperatures down to 83.805K, so temperatures below this value will be reported as an overflow even though the SPRTD is capable of measuring lower. The calibration certificate lists A2, B2, C1, C2, and C3 as the calibration coefficients. You can set up the Model 2002 for this measurement as follows:

1. Set the temperature sensor type to be FRTD (4-wire measurement) from the CONFIG/TEMP/SENSOR/TYPE menu.
2. Choose the SPRTD RTD type using the CONFIG/TEMP/SENSOR/TYPE/FRTD/SPRTD menu.
3. From the SPRTD COEFFICIENTS menu, set the RTD 0°C resistance value and the following coefficients:
 - Set the Model 2002 A4 coefficient to the RTD certificate A2 value.
 - Set the Model 2002 B4 coefficient to the RTD certificate B2 value.

Note that the A7, B7, and C7 values will not be used for this sensor.

4. Switch to the temperature function, and begin taking readings.

THERMOCOUPLE: Select THERMOCOUPLE when using the Model 2001-TCSCAN (installed in the option slot of the Model 2002), or an external thermocouple scanner card (Model 7057A or Model 7402).

- THERMOCOUPLE-TYPE — This menu is used to select the type of thermocouple that you are going to use. Select one of the following thermocouple types:

J, K, T, E, R, S, B, or N

- REF-JUNCTION — Typically, a thermocouple card uses a single reference junction. This menu item is used to select one of the five following reference junctions for further configuration:

JCN1, JCN2, JCN3, JCN4 or JCN5 — After choosing one of these reference junctions you can configure it further or acquire a reference temperature.

- CONFIGURE — This menu item displays the configuration menu for the selected reference junction.

SIMULATED-TEMP — This option allows you to enter a default temperature. Typical reference junction temperatures are 0°C and 23°C. Note the reference junction temperature is shown in the units selected by the SET TEMP UNITS menu.

REAL-JUNCTION — This option lets you enter values for a temperature coefficient for the selected ref-

erence junction (in mV/°C) and an offset voltage (in mV at 0°C). Consult the thermocouple card manual for correct configuration.

- ACQUIRE-REF-TEMP — This option updates the stored reference temperature used for generating a temperature measurement. If the junction type (JCN) is simulated, the defined simulated junction temperature is used. If the junction type is real, you must manually close that channel from the scanner before acquiring the temperature.

INTERNAL-TEMP: This option of the TEMP SENSOR TYPE menu is used to select the internal temperature transducer. With this selection, the internal temperature difference from the calibration temperature of the Model 2002 will be displayed when the TEMP function is selected.

For $T < 0^{\circ}\text{C}$:

$$R_T = R_0[1 + AT + BT^2 + CT^3(T-100)]$$

For $0^{\circ}\text{C} < T < 630^{\circ}\text{C}$:

$$R_T = R_0(1 + AT + BT^2)$$

Where:

$$A = \alpha \left(1 + \frac{\delta}{100} \right)$$

$$B = -\alpha\delta \cdot 10^{-4}$$

$$C = -\alpha\beta \cdot 10^{-8}$$

Above 0°C, the equation solves faster by applying:

$$T = \frac{-A + \sqrt{A^2 - 4B \left(1 - \frac{R_T}{R_0} \right)}}{2B}$$

Below 0°C, it is an iterative solution and it runs slower.

Figure 2-11
Temperature equations

UNITS

This parameter selects the displayed units for temperature measurements.

DEG-C: Displays temperature measurement units in °C.

DEG-F: Displays temperature measurement units in °F.

K: Displays temperature measurement units in K (Kelvin).

There is a multiple display for the temperature function that shows the reading expressed in all three temperature units.

SPEED

The SPEED parameter sets the integration time of the A/D converter, the period of time the input signal is measured (also known as aperture). It is discussed in paragraph 2.4.1, DC and AC voltage. Only the differences for temperature are noted here.

SET-BY-RSLN: This parameter optimizes the integration time for the present resolution setting. The defaults for set-by-resolution integration times of temperature are listed in Table 2-24.

Table 2-24
Temperature integration time set-by-resolution

Resolution degrees	Resolution digits	Integration time
1 degree	3.5d	1.0 PLC
0.1 degree	4.5d	1.0 PLC
0.01 degree	5.5d	1.0 PLC
0.001 degree	6.5d	1.0 PLC

Note: If the integration time is SET-BY-RSLN and the resolution AUTO, the integration time will be 1.0 PLC and the resolution set by sensor.

FILTER

FILTER lets you set the digital filter response. The filter menu is available from the function configuration menus (i.e. CONFIG TEMPERATURE) or by pressing CONFIGURE FILTER with the desired function already selected. All of the parameters (menu items) for FILTER are explained in paragraph 2.9. Since the AUTO parameter has specific effects on TEMP, it is covered here.

The advanced filter is not available for the temperature function.

AUTO: This parameter for a digital filter optimizes its use for the present measurement function. The defaults for automatic filtering of temperature are as follows:

State	Type	Readings	Averaging Mode
On	Averaging	10	Moving

RESLN

Resolution for temperature is not expressed in number of digits, but in fractions of a degree, ranging from 1° to 0.001°.

AUTO: Display resolution is dictated by temperature sensor type. Table 2-25 lists the resolution for the various sensor types.

1°, 0.1°, 0.01°, or 0.001°: Sets display resolution for TEMP.

Table 2-25
Temperature auto resolution

Sensor	Resolution	
	Degree	Digits
RTDs 2-, 3-, or 4-wire	0.01	5.5d
Thermocouples J, K, T, E	0.1	4.5d
Thermocouples R, S, B, N	1	3.5d

Note: If the resolution is AUTO and the integration time SET-BY-RSLN, the integration time will be 1.0 PLC.

Multiple displays

The available multiple displays for temperature depend on the presently selected sensor type, except for the multiple display that shows temperature in three different units:

+0000.0 °C
+0000.0 °F +0000.0 K

RTD measurements have a multiple display for the resistance of the RTD, such as:

RTD Resistance = +0.0000 Ω

Thermocouple measurements have multiple displays for the thermocouple voltage and reference junction temperature. Sample displays are:

Thermocouple Voltage = 0.0000mV
Reference junction = 00.0 °C

Note that the reference junction temperature is shown in the units selected by the SET TEMP UNITS menu. The display of two blinking question marks at the right of the reference junction temperature indicates an overflow of the reference junction measurement. Thermocouple measurements will be made normally using the existing reference temperature value.

2.5 Range

The selected measurement range affects both the ultimate resolution and accuracy of the measurements as well as the maximum signal that can be measured. The range setting (fixed or auto) for each measurement function is saved when changing functions.

2.5.1 Display resolution

The display resolution of a Model 2002 reading depends on the selected range and the resolution setting. The default and maximum display resolutions for every range on each function are included in the specifications of Appendix A.

You can set the display resolution, as described in paragraph 2.4.

2.5.2 Maximum readings

The full scale readings for every range on each function are included in the specifications of Appendix A. Input values more than the maximum reading listed cause the “Overflow” message to be displayed.

2.5.3 Manual ranging

To select a manual range, simply press the RANGE ▲ or ▼ key. The instrument changes one range per key press. The selected range is displayed on the bottom line of the display.

If the instrument displays the “Overflow” message on a particular range, select a higher range until an on-range reading is displayed. Use the lowest range possible without causing an overflow to ensure best accuracy and resolution.

Note that the frequency and temperature functions have just one range. For the frequency functions, the RANGE ▲ and ▼ keys increase and decrease the trigger level by 0.5%. On temperature the keys have no effect.

2.5.4 Autoranging

To enable autoranging, press the AUTO key. The AUTO annunciator turns on when autoranging is selected. While autoranging is selected, the instrument automatically chooses the best range to measure the applied signal.

NOTE

Autoranging should not be used when optimum speed is required.

Note that up-ranging occurs at 105% of range, while down-ranging occurs at 10% of range.

To cancel autoranging, press AUTO or the RANGE ▲ or ▼ key. Pressing AUTO to cancel autoranging leaves the instrument on the present range.

Pressing the RANGE ▼ key when the instrument has autoranged to the lowest range displays the following momentary typical message and leaves the instrument in autorange:

Range at minimum: 200 mVDC

The instrument operates similarly if the RANGE ▲ key is pressed when the instrument has autoranged to the highest range.

For the frequency function, pressing the AUTO key returns the trigger level to 0.0V. The AUTO key has no effect in the temperature function.

2.6 Relative

The rel (relative) operation subtracts a reference value from actual readings. When rel is enabled by the REL key, the instrument uses the present reading as a relative value. Subsequent readings will be the difference between the actual input value and the rel value. You can also enter and enable a relative value from the CONFIG-REL display (see paragraph 2.6.1).

A rel value can be established for each measurement function. The state and value of rel for each measurement function are saved when changing functions.

Once a rel value is established for a measurement function, the value is the same for all ranges. For example, if 150V is set as a rel value on the 200V range, the rel is also 150V on the 1000V, 20V, 2V, and 200mV ranges.

A relative value can be as large as the highest range for the particular function. Table 2-26 lists the allowable range of rel values for each function.

Selecting a range that cannot accommodate the rel value does not cause an overflow condition, but it also does not increase the maximum allowable input for that range. For example, on the 2mA range, the Model 2002 still overflows for a 2.1mA input.

Table 2-26
Allowable rel values

Function	Rel range	
DC voltage	-1.1e3 to +1.1e3	(±1100V)
AC voltage	-7.75e2 to +7.75e2	(±775V)
DC current	-1.2e1 to +1.2e1	(±12A)
AC current	-2.1e0 to +2.1e0	(±2.1A)
2-wire resistance	0 to +1.05e9	(0 to 1.05GΩ)
4-wire resistance	0 to +2.1e6	(0 to 2.1MΩ)
Frequency	0 to +1.5e7	(0 to 15MHz)
Temperature	-3.28e2 to +3.31e3	(-328 to +3310°)

2.6.1 Configuring rel

Pressing CONFIGURE REL displays the rel value for the present measurement function. You can change the rel value using the cursor keys (◀ and ▶) and the RANGE ▲ and ▼ keys. When ENTER is pressed, the instrument returns to the measurement display state with that value of rel enabled.

If you try to enter an invalid rel value, a message indicating the rel limit will be displayed and the rel operation will be cancelled.

Previously stored rel values are converted if temperature or AC voltage units are changed. For example, a rel value of 100 that was stored with units of DEG-C is converted to 212 if temperature units are changed to DEG-F.

Note that a bench or GPIB reset clears any stored rel values and disables rel for all functions.

2.6.2 Enabling rel

From the normal reading display, the REL key toggles the rel operation on and off. Each time rel is enabled by the REL key, the present reading becomes the new rel value for that function. You cannot rel an overflow reading.

To make a new reading the rel value, rel must first be disabled and then enabled again. Disabling rel does not clear any stored rel value.

When rel is enabled, the resulting reading is the algebraic difference between the actual input value and the rel value:

$$\text{rel'd reading} = \text{actual value} - \text{relative value}$$

With math enabled, the rel'd reading is acted on by the math operation:

$$\text{displayed reading} = \text{math operation}(\text{rel'd reading})$$

A rel value expressed in dB or dBm is applied after the reading is referenced to the selected level.

2.6.3 Multiple display of rel

One of the “multiple displays” allows you to view the reading without rel applied on the bottom line of the display and the rel'd reading on the top line. The display is available by repeatedly pressing either the NEXT or PREVIOUS DISPLAY key to scroll through the multiple displays of the particular function. The following is a typical message for a rel multiple display:

```
+000.012 mVAC RMS
Actual=+001.012 (without REL)
```

2.7 Triggers

The following paragraphs discuss front panel triggering, trigger configuration, and external triggering, including example setups.

Model 2002 triggers are set up in the CONFIGURE TRIGGER menu. The menu structure is shown and summarized in Table 2-27. Some general rules to navigate menus are given in paragraph 2.3.4.

2.7.1 Trigger model

The following information describes triggering of the Model 2002 from the front panel. The flowchart of Figure 2-12 summarizes front panel triggering. It is called the Trigger Model because it is patterned after the SCPI commands sent over the IEEE-488 bus to control triggering.

Table 2-27
CONFIGURE TRIGGER menu structure

Menu item	Description
MEASURE SOURCE IMMEDIATE EXTERNAL MANUAL GPIB TRIGLINK TIMER HOLD DELAY COUNT INFINITE ENTER-CHAN-COUNT CONTROL SOURCE ACCEPTOR	Measure layer menu: Select measure source: Use to make measurements immediately. Use external triggers to control measuring. Use TRIG key to control measuring. Use bus triggers to control measuring. Use Trigger Link triggers to control measuring. Enter Trigger Link mode and lines. Use a timer to control measuring and enter interval between triggers (0.001-999999.999sec.). Use to hold up the measurement in the measure layer. Use to delay measurement in the measure layer (0.001-999999.999sec.). Define number of measurements to make: Repeat measuring indefinitely. Count = use defined value (1-99999). Select trigger control mode: Enable Source Bypass. Disable Source Bypass.
SCAN SOURCE IMMEDIATE EXTERNAL MANUAL GPIB TRIGLINK TIMER HOLD DELAY COUNT INFINITE ENTER-SCAN-COUNT CONTROL SOURCE ACCEPTOR	Scan layer menu: Select scan source: Use to pass operation immediately into the measure layer. Use external triggers to control scanning. Use TRIG key to control scanning. Use bus triggers to control scanning. Use Trigger Link triggers to control scanning. Enter Trigger Link lines. Use a timer to control scanning and enter interval between scans (0.001-999999.999sec.). Use to hold up the measurement in the scan layer. Use to delay scan in the scan layer (0.001-999999.999sec.). Define number of scans to be performed: Repeat scanning indefinitely. Count = user defined value (1-99999). Select trigger control mode: Enable Source Bypass. Disable Source Bypass.

Table 2-27
CONFIGURE TRIGGER menu structure (cont.)

Menu item	Description
ARM SOURCE IMMEDIATE EXTERNAL MANUAL GPIB TRIGLINK RT-CLOCK HOLD COUNT INFINITE ENTER-ARM-COUNT CONTROL SOURCE ACCEPTOR	Arm layer menu: Select arm source: Use to arm meter immediately and pass operation into the scan layer. Use external triggers to arm meter. Use TRIG key to arm meter. Use bus triggers to arm meter. Use Trigger Link triggers to arm meter. Enter Trigger Link lines. Use clock to arm meter. Enter time and date. Use to hold up the measurement in the arm layer. Define number of times to arm meter: Continuously re-arm meter. User defined count value (1-99999). Select trigger control mode: Enable Source Bypass. Disable Source Bypass.
HALT	Use to halt triggers. Press TRIG key to resume triggering.

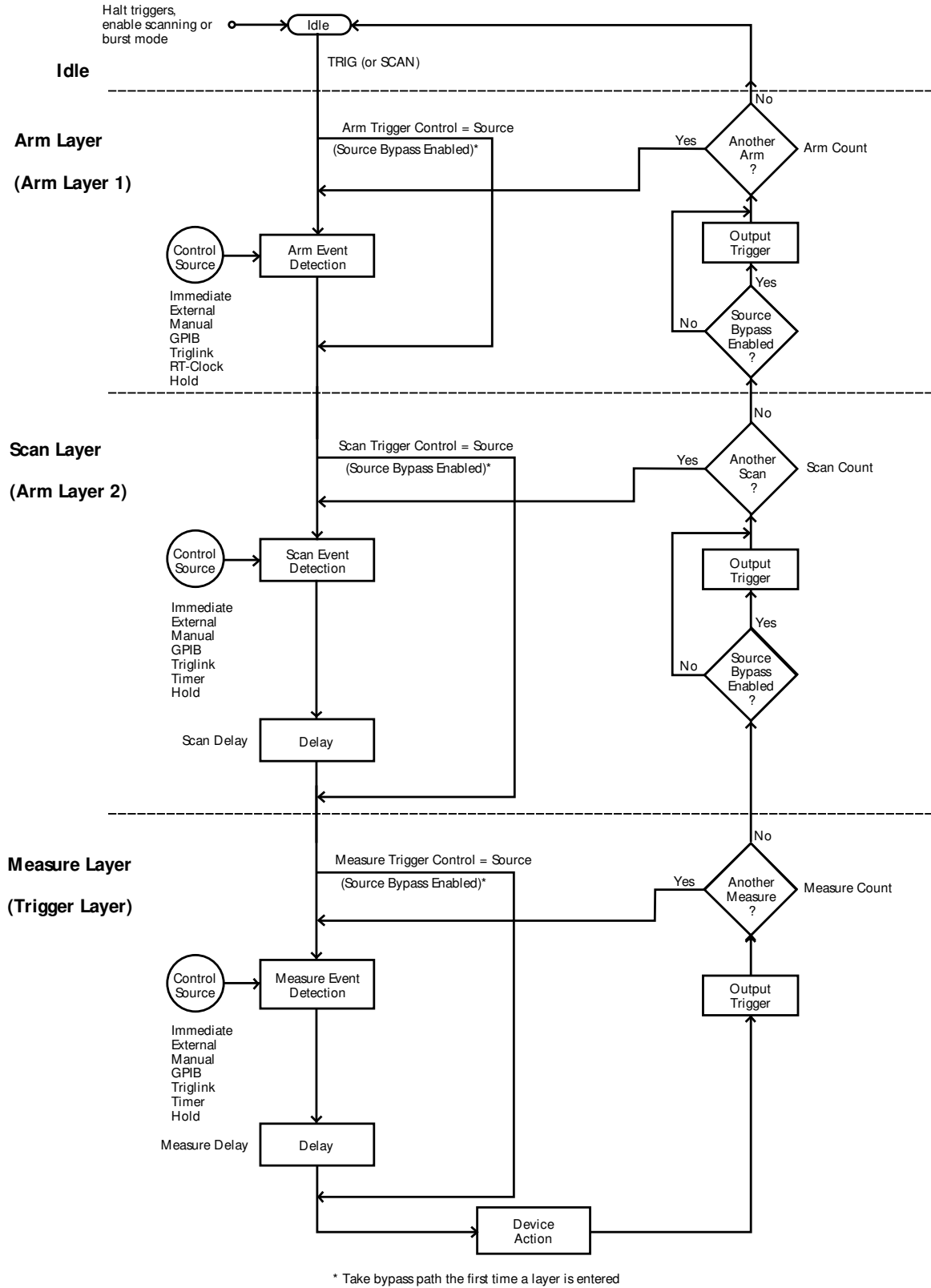

Figure 2-12
Trigger model (front panel operation)

Idle

The instrument is considered to be in the idle state whenever it is not operating within one of the three layers of the Trigger Model. The front panel ARM indicator is off when the instrument is in the idle state. While in the idle state, the instrument cannot perform any measurement or scanning functions.

From the front panel there are four ways to put the instrument into idle:

- Select RESET GPIB from the SAVESETUP option of the main menu. Press the TRIG key to take a reading. After each reading, the instrument returns to the idle state.
- Select HALT from the CONFIGURE TRIGGER menu. Press the TRIG key to resume triggering.
- Enable BURST-MODE from the CONFIGURE DATA STORE menu. This places the instrument in idle until the TRIG key is pressed. After each burst acquisition the instrument returns to idle.
- Configure an internal or external scan with the SCAN key. Disabling the scan resumes triggering.

Trigger Model Layers

As can be seen in Figure 2-12, the trigger model uses three layers: the Arm Layer, Scan Layer and Measure Layer. For IEEE-488 bus operation, these layers are known as Arm Layer 1, Arm Layer 2 and the Trigger Layer.

Once the Model 2002 is taken out of the idle state, operation proceeds through the layers of the trigger model down to the device action where a measurement occurs.

Control Sources — In general, each layer contains a control source which holds up operation until the programmed event occurs. The control sources are described as follows:

- Immediate — With this control source selected, event detection is immediately satisfied allowing operation to continue.
- Manual — Event detection is satisfied by pressing the TRIG key. Note that the Model 2002 must be taken out of remote before it will respond to the TRIG key. Pressing LOCAL or sending LOCAL 716 over the bus takes the instrument out of remote.
- GPIB — Event detection is satisfied when a bus trigger (GET or *TRG) is received by the Model 2002.
- RT-Clock — Event detection in the Arm Layer is satisfied when the programmed time and date occurs. The real-time clock control source is not available in the Scan Layer and Measure Layer.

- Timer — Event detection is immediately satisfied on the initial pass through the layer. Each subsequent detection is satisfied when the programmed timer interval (1 to 999999.999 seconds) elapses. A timer resets to its initial state when operation loops back to a higher layer (or idle). Note that a timer is not available in the Arm Layer.
- External — Event detection is satisfied when an input trigger via the EXTERNAL TRIGGER connector is received by the Model 2002.
- Triglink — Event detection is satisfied when an input trigger via the TRIGGER LINK is received by the Model 2002.
- Hold — With this selection, event detection is not satisfied by any of the above control source events and operation is held up.

Source Bypasses — As can be seen in the flowchart, each layer has a path that allows operation to loop around the control source. Each path is called a source bypass.

When a source bypass is enabled, and the external or trigger link (triglink) control source is selected, operation loops around the control source on the initial pass through the layer. If programmed for another event detection in the layer, the bypass loop will not be in effect though it is still enabled. The bypass loop resets (be in effect) if operation loops back to a higher layer (or idle).

In the Arm Layer and Scan Layer, enabling a source bypass also enables the respective output trigger. In the Trigger Layer, its output trigger is always enabled and occurs after every device action. See Output Triggers for more information.

Delays — The Scan Layer and the Measure Layer have a programmable delay (0 to 999999.999 seconds) that is enforced after an event detection.

Device Action — The primary device action is a measurement. However, the device action could include a function change and a channel scan (if scanner is enabled). A channel is scanned (closed) before a measurement is made. When scanning internal channels, the previous channel opens and the next channel closes (break-before-make). Also included in the device action is the internal settling time delay for the relay.

Output Triggers — In the Arm Layer and Scan Layer the output triggers are enabled only if their respective source bypasses are also enabled. If a trigger link (triglink) control source is selected, the output trigger pulse is available on the selected TRIGGER LINK output line. For all other control

source selections, the trigger pulse is available at the METER COMPLETE connector.

In the Measure Layer, the output trigger is always enabled and occurs after every device action. If the control source is set for external, immediate, manual, GPIB or timer, the output trigger pulse is available at the METER COMPLETE connector. If the trigger link (triglink) control source is selected, output trigger action occurs on the selected TRIGGER LINK output line as follows:

- If the asynchronous Trigger Link mode is selected, the output trigger pulse is available on the programmed output line.
- If the semi-synchronous Trigger Link mode is selected and the source bypass is disabled, the Trigger Link line is released (goes high).
- If the semi-synchronous Trigger Link mode is selected and the source bypass is enabled, the Trigger Link line is pulled down low and then released.

Counters — All three layers use programmable counters which allow operation to return to or stay in the respective layer. For example, programming the Measure Layer counter for infinity keeps operation in the Measure Layer. After each device action and subsequent output trigger, operation loops back to the Trigger Layer control source. A counter resets when operation loops back to a higher layer (or idle).

2.7.2 Configuring the measure layer

The measure layer is used for the following operations:

- To select the measuring event (SOURCE) for the instrument.
- To delay operation in the measure layer.
- To designate the number of measurements the instrument will make (COUNT).
- To enable or disable the Source Bypass.

The measure layer is configured from the MEASURE item of the CONFIGURE TRIGGER menu, which is displayed by pressing the CONFIG key and then the TRIG key. General rules for navigating through the menu structure one contained in paragraph 2.3.4.

SOURCE

This menu item selects the event that controls the measure source.

IMMEDIATE: With this selection, events (such as TIMER and EXTERNAL triggers) do not control the measurement interval. Once the Model 2002 starts measuring, it will take readings as fast as its measurement configuration allows.

EXTERNAL: With this selection, external triggers are used to control the measure source. Each trigger stimulus applied to the Model 2002 performs a device action, as defined by the trigger model. In addition to a measurement, this may include range changing, filtering, calculations, data storing, scanning, and other operations.

The external trigger is applied to the rear panel “EXTERNAL TRIGGER” BNC connector. See paragraph 2.7.6 for detailed information on external triggering.

NOTE

The front panel TRIG key (see MANUAL) is active with external triggering selected. Pressing the TRIG key performs a device action.

MANUAL: With this selection, the front panel TRIG key controls the measure source. A device action is performed when the TRIG key is pressed.

NOTE

The front panel TRIG key is active when EXTERNAL, GPIB, TRIGLINK, or TIMER is selected.

GPIB: With this selection, bus triggers control the measure source. When the Model 2002 receives a bus trigger (GET or *TRG), it performs a device action, as defined by the trigger model. In addition to a measurement, this may include range changing, filtering, calculations, data storing, scanning, and other operations. See Section 3 for detailed information on bus triggers.

NOTE

The front panel TRIG key (see MANUAL) is active with bus triggering selected. Pressing the TRIG key performs a device action.

TRIGLINK: With this selection, the measure source is controlled by the Trigger Link of the Model 2002. Trigger Link is an enhanced trigger system that uses up to six lines to direct trigger pulses to and from other instruments.

When the Model 2002 receives a trigger over the Trigger Link, it performs a device action, as defined by the trigger model. In addition to a measurement, this may include range changing, filtering, calculations, data storing, scanning, and other operations.

See paragraph 2.7.7 for details on using the Trigger Link.

NOTE

The front panel TRIG key (see MANUAL) is active with the Trigger Link selected. Pressing the TRIG key performs a device action.

After selecting TRIGLINK as the measurement event, select one of the following trigger link modes:

- **ASYNCHRONOUS** — The asynchronous trigger link mode is used for trigger configurations that require input and output triggers to be routed on separate lines. After selecting this trigger link mode, you will be prompted to select an input line and then an output line. Note that you cannot use the same trigger line for both input and output.
- **SEMI-SYNCHRONOUS** — In this mode, the input and output triggers for the Model 2002 are assigned to the same line. After selecting this trigger link mode, you will be prompted to select the trigger line.

TIMER: Use the timer to control the time interval between measurements.

The timer can be set for an interval from 0.001 seconds (1msec) to 999999.999 seconds with 1msec resolution.

After a measurement is triggered to start, the next measurement starts at the end of the programmed timer interval. If however, the programmed timer interval is shorter than the time it takes to complete a single measurement, the next measurement does not start until the previous one is done.

NOTE

The front panel TRIG key (see MANUAL) is active with the timer selected. Pressing the TRIG key after the completion of a measurement starts the next measurement (assuming the Model 2002 is programmed for another measurement; see COUNT).

HOLD: When HOLD is selected, the measure source is suppressed. As a result, measuring is stopped and does not continue until HOLD is cancelled by selecting one of the other measure source selections. Select HOLD from the SELECT MEASURE SRC menu by placing the cursor on HOLD and pressing ENTER. The instrument returns to the SETUP measure layer menu.

DELAY

This delay is used to hold up operation in the measure layer. After the measure event occurs, the instrument waits until the delay period times out (0 - 999999.999sec) before performing a device action.

COUNT

With this selection, you determine the number (count) of measurements per scan sequence. The user programmed count can be smaller, equal to, or larger than the number of channels in the scan list. For example, if the scan list is made up of four channels, you can program a count of 12. With this count value, the instrument repeats the scan three times. An advantage of repeating channels (rather than scans) is that delays in the scan layer of operation are avoided. The measure delays among all 12 channels are the same.

INFINITE: Use this selection to continuously repeat measurements (and looping in the measure layer).

ENTER-CHAN-COUNT: With this selection, the user determines the number of readings per scan. You can program the Model 2002 to measure up to 99999 times.

CONTROL

Use this menu item to enable or disable the source bypass. The source bypass is used to bypass the measure event on the first pass through the measure layer.

SOURCE: With this selection, the source bypass is enabled. The measure event will be bypassed on the first pass through the scan layer. This allows operation to proceed to the Delay and Device Action without having to wait for the programmed event.

ACCEPTOR: With this selection, the source bypass is disabled.

2.7.3 Configuring the scan layer

The scan layer is used for the following operations:

- To select the scanning event (SOURCE) for the instrument.
- To delay operation in the scan layer.
- To designate the number of scan sequences the instrument will perform (COUNT).
- To enable or disable the Source Bypass.

The scan layer is configured from the SCAN item of the CONFIGURE TRIGGER menu, which is displayed by pressing the CONFIG key and then the TRIG key. General rules for navigating through the menu structure is contained in paragraph 2.3.4.

SOURCE

This menu item selects the event that controls the scan source.

IMMEDIATE: With this selection, operation passes immediately into the measure layer.

EXTERNAL: With this selection, external triggers are used to control the scan source. A trigger stimulus applied to the Model 2002 passes operation into the measure layer. The external trigger is applied to the rear panel “EXTERNAL TRIGGER” BNC connector. See paragraph 2.7.6 for detailed information on external triggering.

NOTE

The front panel TRIG key (see MANUAL) is active with external triggering selected. Pressing the TRIG key passes operation into the measure layer.

MANUAL: With this selection, the front panel TRIG key controls the scan source. Operation passes into the measure layer when the TRIG key is pressed.

NOTE

The front panel TRIG key is active when EXTERNAL, GPIB, TRIGLINK, or TIMER is selected.

GPIB: With this selection, bus triggers control the scan source. Operation passes immediately into the measure layer when a bus trigger (GET or *TRG) is received by the Model 2002. See Section 3 for detailed information on bus triggers.

NOTE

The front panel TRIG key (see MANUAL) is active with bus triggering selected. Pressing the TRIG key passes operation into the measure layer.

TRIGLINK: With this selection, the scan source is controlled by the Trigger Link of the Model 2002. Trigger Link is an enhanced trigger system that uses up to six lines to direct trigger pulses to and from other instruments. Operation passes into the measure layer when the Model 2002 receives a trigger over the Trigger Link. See paragraph 2.7.7 for details on using the Trigger Link.

NOTE

The front panel TRIG key (see MANUAL) is active with the Trigger Link selected. Pressing the TRIG key passes operation into the measure layer.

After selecting TRIGLINK, you will be prompted to select an input line and then an output line. Note that you cannot use the same trigger line for both input and output.

TIMER: Use the timer feature to control the time interval between scan sequences when scanning. The timer can be set for an interval from 0.001 seconds (1msec) to 999999.999 seconds with 1msec resolution.

After a scan sequence is triggered to start, the next scan sequence starts at the end of the programmed timer interval. If however, the programmed timer interval is shorter than the time it takes to complete a single scan sequence, the next scan sequence does not start until the previous one is done.

NOTE

The front panel TRIG key (see MANUAL) is active with the timer selected. Pressing the TRIG key after the completion of a scan sequence starts the next scan sequence (assuming the Model 2002 is programmed for another scan sequence; see COUNT).

HOLD: When HOLD is selected, the scan source is suppressed. As a result, operation does not pass into the measure layer until HOLD is cancelled by selecting one of the other scan source selections. Select HOLD from the SELECT SCAN SOURCE menu by placing the cursor on HOLD and pressing ENTER. The instrument returns to the SETUP SCAN LAYER menu.

DELAY

This delay is used to hold up operation in the scan layer. After the scan event occurs, the instrument waits until the delay period times out (0 to 999999.999sec) before proceeding to the measure layer.

COUNT

This menu item defines the number of times operation returns to the scan layer.

INFINITE: Use this selection to continuously return operation to the scan layer.

ENTER-SCAN-COUNT: With this selection, the user determines the number of times operation returns to the scan layer. You can program the Model 2002 to scan up to 99999 times.

CONTROL

Use this menu item to enable or disable the source bypass. The source bypass is used to bypass the scan event on the first pass through the scan layer.

SOURCE: With this selection, the source bypass is enabled. The scan event will be bypassed on the first pass through the scan layer. This allows operation to proceed into the measure layer without having to wait for the programmed event.

ACCEPTOR: With this selection, the source bypass is disabled.

2.7.4 Configuring the arm layer

The arm layer is used for the following operations:

- To select the arming event (SOURCE) for the instrument.
- To designate the number of times the instrument is to be armed (COUNT).
- To enable or disable the Source Bypass.

The arm layer is configured from the ARM item of the CONFIGURE TRIGGER menu, which is displayed by pressing the CONFIG key and then the TRIG key. General rules for navigating through the menu structure is contained in paragraph 2.3.4.

SOURCE

This menu item selects the event that controls the arm source.

IMMEDIATE: With this selection, operation passes immediately into the scan layer.

EXTERNAL: With this selection, external triggers are used to control the arm source. A trigger stimulus applied to the Model 2002 passes operation into the scan layer. The external trigger is applied to the rear panel “EXTERNAL TRIGGER” BNC connector. See paragraph 2.7.6 for detailed information on external triggering.

NOTE

The front panel TRIG key (see MANUAL) is active with external triggering selected. Pressing the TRIG key passes operation into the scan layer.

MANUAL: With this selection, the front panel TRIG key controls the arm source. Operation passes into the scan layer when the TRIG key is pressed.

NOTE

The front panel TRIG key is active when EXTERNAL, GPIB, or TRIGLINK is selected.

GPIB: With this selection, bus triggers control the arm source. Operation passes immediately into the scan layer when a bus trigger (GET or *TRG) is received by the Model 2002. See Section 3 for detailed information on bus triggers.

NOTE

The front panel TRIG key (see MANUAL) is active with bus triggering selected. Pressing the TRIG key passes operation into the scan layer.

TRIGLINK: With this selection, the arm source is controlled by the Trigger Link of the Model 2002. Trigger Link is an enhanced trigger system that uses up to six lines to direct trigger pulses to and from other instruments. Operation passes into the scan layer when the Model 2002 receives a trigger over the Trigger Link. See paragraph 2.7.7 for details on using the Trigger Link.

NOTE

The front panel TRIG key (see MANUAL) is active with the Trigger Link selected. Pressing the TRIG key passes operation into the scan layer.

After selecting TRIGLINK, you will be prompted to select an input line and then an output line. Note that you cannot use the same trigger line for both input and output.

RT-Clock: With this selection, the arm source is controlled by the real-time clock. When the programmed time and date occurs, the Model 2002 passes operation into the scan layer.

- **SET-TIME** — Use this selection to set the time (hour, minute and second) for the arm event. Set the time using the 12-hour format of “AM” or “PM” is displayed (see CLOCK in paragraph 2.12.7). Otherwise, set the time using the 24-hour format.
- **SET-DATE** — Use this selection to set the date (month, day and year) for the arm event.

HOLD: When HOLD is selected, the arm source is suppressed. As a result, operation does not pass into the scan layer until HOLD is cancelled by selecting one of the other arm source selections. Select HOLD from the SELECT ARM SOURCE menu by placing the cursor on HOLD and pressing ENTER. The instrument returns to the SETUP arm layer menu.

COUNT

This menu item defines the number of times operation returns to the arm layer.

INFINITE: Use this selection to continuously return operation to the arm layer.

ENTER-ARM-COUNT: With this selection, the user determines the number of times operation returns to the arm layer. You can program the Model 2002 to arm up to 99999 times.

CONTROL

Use this menu item to enable or disable the source bypass. The source bypass is used to bypass the arm event on the first pass through the arm layer.

SOURCE: With this selection, the source bypass is enabled. The arm event will be bypassed on the first pass through the arm layer. This allows operation to proceed into the scan layer without having to wait for the programmed event.

ACCEPTOR: With this selection, the source bypass is disabled.

2.7.5 Halting triggers

The Halt option of the CONFIGURE TRIGGER menu is used to disarm the instrument and place it in the idle state. You can press the TRIG key to resume front panel triggers.

2.7.6 External triggering

The Model 2002 has BNC connections on the rear panel for external triggering (see Figure 2-13). The EXTERNAL TRIGGER INPUT jack allows the Model 2002 to be triggered by other instruments. The METER COMPLETE OUTPUT jack allows the Model 2002 to trigger other instruments.

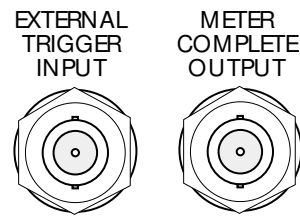

Figure 2-13
External triggering connectors (BNC)

External trigger

The EXTERNAL TRIGGER INPUT jack requires a falling-edge, TTL-compatible pulse with the specifications shown in Figure 2-14.

In general, external triggers can be used as events to control measure operations. For the Model 2002 to respond to external triggers, the appropriate layers of trigger model must be configured for it. Paragraphs 2.7.2 through 2.7.4 explain how to program the three layers of the measurement.

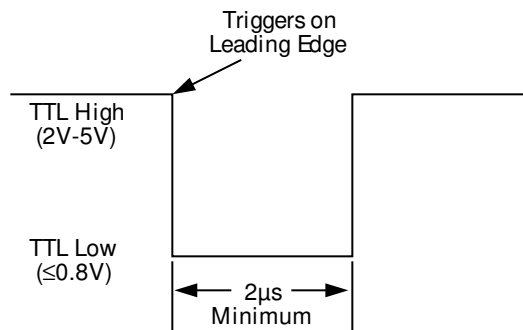

Figure 2-14
External triggering and asynchronous trigger link input pulse specifications

Meter complete

The METER COMPLETE OUTPUT jack provides a TTL-compatible output pulse that can be used to trigger other instruments. The specifications for this trigger pulse are shown in Figure 2-15.

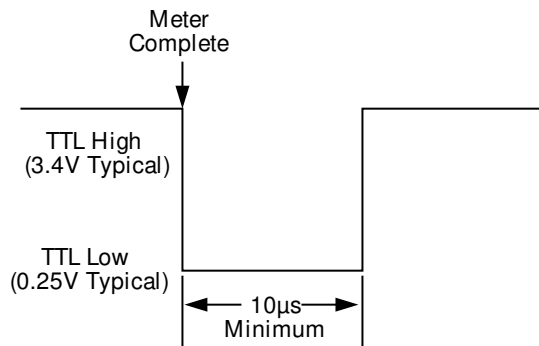

Figure 2-15
Meter complete and asynchronous trigger link output pulse specifications

Typically, you would want the Model 2002 to output a trigger after the settling time of each measurement. (Settling time includes the internally set measurement settling time and the user programmed DELAY period.) An output completion pulse occurs after each measurement as long as the measure source is set to external, timer, manual, or immedi-

ate. See paragraph 2.7.2 for details on programming the measure layer.

The Model 2002 can also output a completion pulse while in the scan and/or arm layers of operation. Figure 2-12 shows where these triggers occur in the trigger model. If the scan layer Source Bypass is enabled (Control = Source) and the Scan Source is programmed for External, an output trigger occurs on each return path through the scan layer. If the arm layer Source Bypass is enabled (Control = Source) and the Arm Source is programmed for External, an output trigger occurs on each return path through the arm layer. See paragraphs 2.7.3 and 2.7.4 for programming the Scan and arm layers.

External triggering example #1

In a typical test system, you may want to close a channel and then measure the DUT connected to that channel with a multimeter. Such a test system is shown in Figure 2-16, which uses a Model 2002 Multimeter to measure ten DUTs switched by a Model 7011 multiplexer card in a Model 7001 or 7002 Switch System.

The external trigger connections for this test are shown in Figure 2-17. Channel Ready (output) of the Model 7001 or 7002 is connected to External Trigger Input of the Model 2002. Meter Complete Output of the Model 2002 is connected to External Trigger (input) of the Model 7001 or 7002.

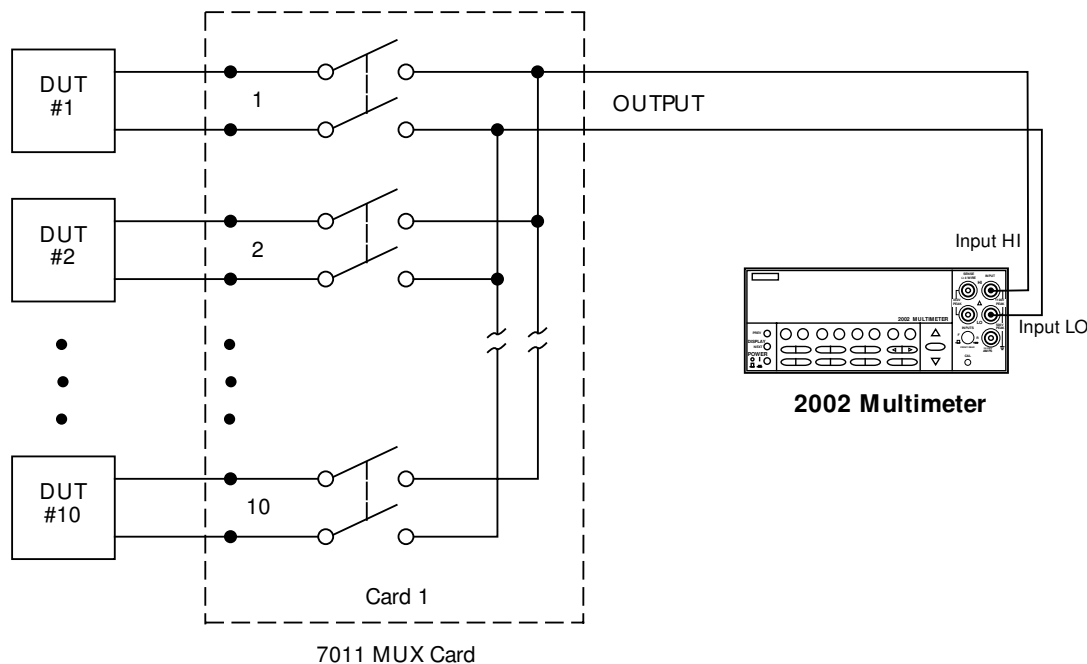

Figure 2-16
DUT test system

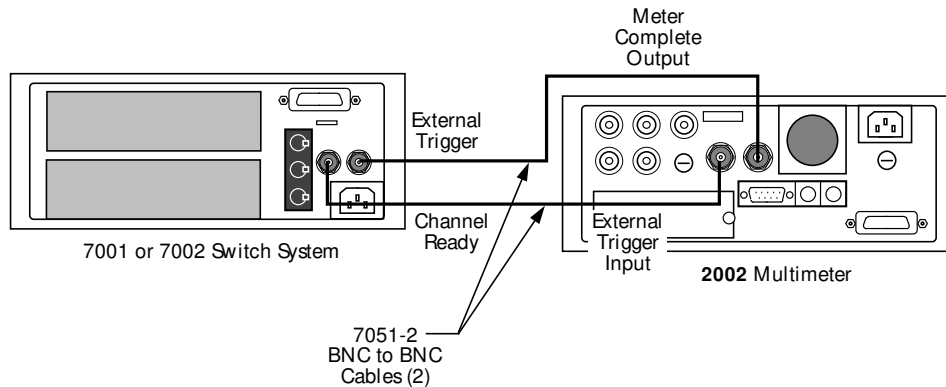

Figure 2-17
External trigger connectors

For this example, the Models 2002 and 7001/7002 are configured as follows:

Model 2002:

Idle State:

Bench reset = :INIT:CONT ON*

Arm layer:

Arm source = Immediate*

Arm count = 1*

Arm trigger control = Acceptor*

Scan layer:

Scan source = Immediate*

Scan count = Infinite*

Scan trigger control = Acceptor*

Measure layer:

Measure source = External

Measure count = Infinite*

Measure trigger control = Acceptor*

* Indicates that the setting is the BENCH RESET (and factory) default condition.

Model 7001 or 7002:

Idle State:

Reset = :INIT:CONT OFF*

Scan List = 1!1-1!10,

Arm layer:

Arm spacing = Immediate*

Arm count = 1*

Arm trigger control = Acceptor*

Scan layer:

Scan spacing = Immediate*

Number of scans = 1

Scan trigger control = Acceptor*

Channel Layer:

Channel spacing = External

Number of channels = Use Scanlist length*

Channel trigger control = Source*

* Indicates that the setting is the RESET (and factory) default condition.

Notice that the Model 2002 is reset to BENCH defaults. With this selection, the multimeter stays armed. Since the arm source and scan source are set to Immediate, the Model 2002 waits in the measure layer for a trigger.

With the Channel Trigger Control of the switch system set for Source, scan operation initially bypasses the need for an external trigger to close the first channel. Since arm spacing and scan spacing are set to Immediate, the scan starts as soon as the scanner is taken out of the idle state by pressing the STEP key. When the front panel STEP key is pressed:

- The scanner arms and closes the first channel.
- After Channel 1!1 settles, a trigger is sent from Channel Ready of the Model 7001/7002 to External Trigger Input of the Model 2002 to trigger a measurement of DUT #1.
- After the Model 2002 completes the measurement, it outputs a trigger from Meter Complete Output to External Trigger of the Model 7001/7002, which closes the next channel.
- After Channel 1!2 settles, a trigger is sent to the Model 2002 to trigger a measurement of DUT #2.

This process continues until all ten channels are scanned and measured.

The data store capability of the Model 2002 could be used to store the measurements as they occur. Just press the STORE

key to set the number of readings to store, then press ENTER. The Model 2002 waits (with the asterisk annunciator lit) for an external trigger from the Model 7001/7002 before taking a reading, storing it, and sending a trigger pulse.

External triggering example #2

External triggering can also be used in a test system consisting of a Model 2002 Multimeter and a Model 706 Scanner with an appropriate scanner card.

The external trigger connections are the same as those shown in Figure 2-17 for the Models 2002 and 7001/7002. Channel Ready Output of the Model 706 is connected to External Trigger Input of the Model 2002. External Trigger Input of the Model 706 is connected to Meter Complete Output of the Model 2002.

The trigger configuration of the Model 2002 does not change from the previous example. The Model 706 is configured for external triggering.

2.7.7 Trigger Link

The Model 2002 has enhanced external triggering capabilities using the Trigger Link. The Trigger Link has six lines allowing up to six instruments to be controlled over this trigger bus. The 8-pin micro-DIN sockets used for the Trigger Link are shown in Figure 2-18.

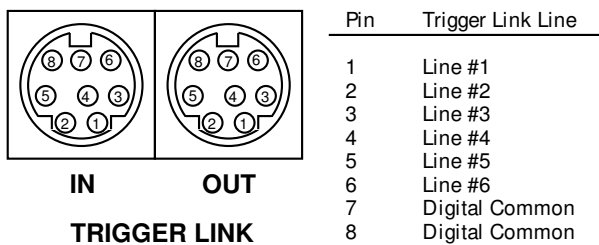

Figure 2-18
Trigger link connectors

NOTE

The two rear panel Trigger Link connectors are actually connected in parallel. It does not matter which connector you use when connecting the Trigger Link to another instrument.

In general, Trigger Link input triggers to the Model 2002 are used to control the measure operation. For the Model 2002 to respond to Trigger Link compatible triggers, the appropriate layers of the trigger model must be programmed for it. For example, if you want Trigger Link input triggers to control the measuring process, you must program Measure Source for TRIGLINK trigger events. Typically, a Trigger Link output trigger from the Model 2002 would be used to trigger a scanner to close the next channel.

There are two modes of operation for Trigger Link: asynchronous and semi-synchronous. In the asynchronous mode, separate lines are used for input and output triggers; in the semi-synchronous mode, the same line is used for both input and output triggers.

Asynchronous operation

In the asynchronous operating mode, Trigger Link functions fundamentally in the same manner as External Triggering (see paragraph 2.7.6). Like External Triggering, the asynchronous mode uses separate lines for input and output triggers. Also, the asynchronous mode uses the same TTL-compatible pulses as External Triggering. The specifications for the input and output trigger signals of asynchronous mode are shown in Figure 2-14 and Figure 2-15, respectively.

For typical asynchronous Trigger Link operation, the measure layer is configured with Measure Source set to TRIGLINK and Triggerlink mode set to ASYNCHRONOUS. You must also select input and output lines for the measure layer. Input and output triggers can be set to any of the six lines, but they cannot use the same line. For example, if you select line #1 for input triggers, then output triggers must use one of the other five lines (#2 through #6).

During operation in the measure layer, each Trigger Link input trigger makes a measurement. After the user-programmed DELAY and the measurement settling time, the Model 2002 outputs a Trigger Link completion pulse (typically to a scanner to close the next channel). The measure layer is configured using the CONFIG-TRIG menu (see paragraph 2.7.2).

The scan layer and/or arm layer can also be programmed for Trigger Link, where Scan Source is set to TRIGLINK, and Arm Source is set to TRIGLINK. When using Trigger Link in these layers, you must also select input and output lines as you did in the measure layer. Keep in mind that you can use the same lines in the Scan and arm layers as selected in the measure layer.

Asynchronous Trigger Link example #1

In a typical test system, you may want to close a channel and then measure the DUT connected to the channel with a multimeter. Such a test system is shown in Figure 2-19, which uses a Model 2002 Multimeter to measure ten DUTs switched by a Model 7011 multiplexer card in a Model 7001/7002 Switch System.

The Trigger Link connections for this test system are shown in Figure 2-20. Trigger Link of the Model 2002 is connected to Trigger Link of the Model 7001/7002 Switch System. Notice that only one Trigger Link cable is needed.

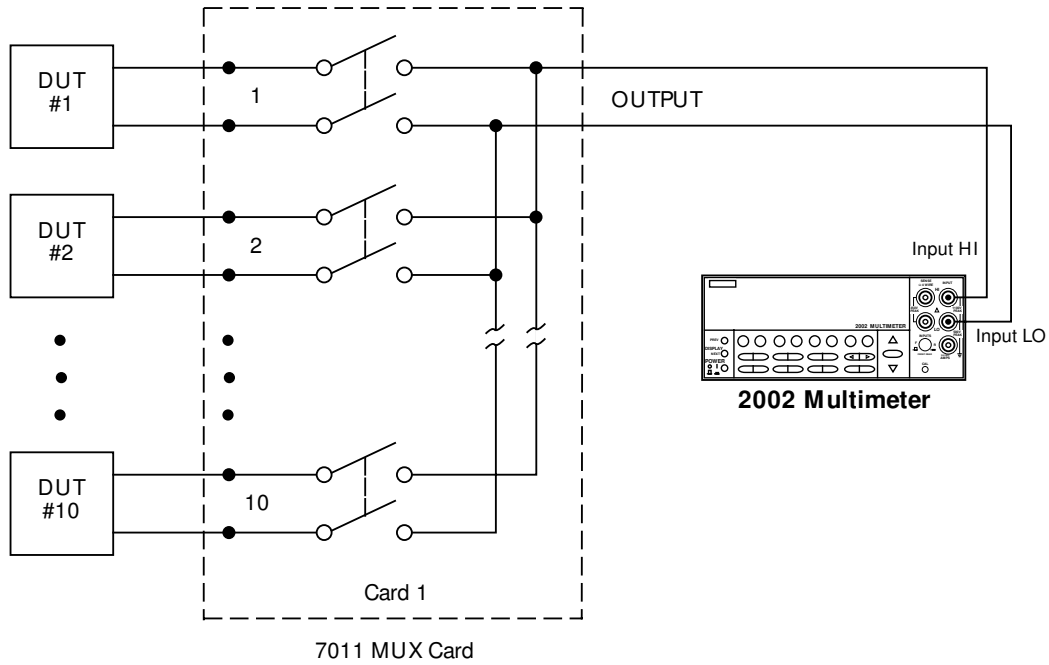

Figure 2-19
DUT test system

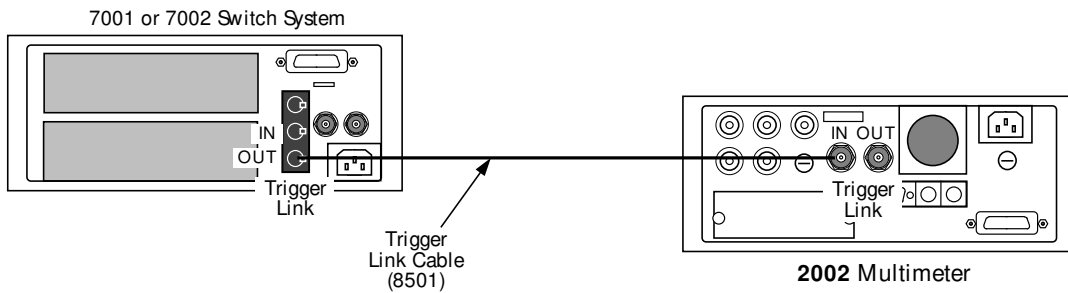

Figure 2-20
Trigger Link connections (asynchronous example #1)

For this example, the Models 2002 and 7001/7002 are configured as follows:

Model 2002:

Idle state:

Bench reset = :INIT:CONT ON*

Arm layer:

Arm source = Immediate*

Arm count = 1*

Arm trigger control = Acceptor*

Scan layer:

Scan source = Immediate*

Scan count = Infinite*

Scan trigger control = Acceptor*

Measure layer:

Measure source = TrigLink

Trigger link mode = Asynchronous*

Input line = #2*

Output line = #1*

Measure count = 10

Measure trigger control = Acceptor*

* Indicates that the setting is the BENCH RESET (and factory) default condition.

Model 7001 or 7002:

Idle state:

Reset = :INIT:CONT OFF*

Scan list = 1!1-1!10,

Arm layer:

Arm spacing = Immediate*

Arm count = 1*

Arm trigger control = Acceptor*

Scan layer:

Scan spacing = Immediate*

Number of scans = 1

Scan trigger control = Acceptor*

Channel Layer:

Channel spacing = TrigLink

Trigger link mode = Asynchronous*

Input line = #1*

Output line = #2*

Number of channels = Use Scanlist length*

Channel trigger control = Source*

* Indicates that the setting is the RESET (and factory) default condition.

Notice that the Model 2002 is reset to BENCH defaults. With this selection, the multimeter stays armed. Since the arm source and scan source are set to Immediate, the Model 2002 waits in the measure layer for a trigger.

With the Channel Trigger Control of the Model 7001/7002 set for Source, scan operation initially bypasses the need for

a Trigger Link trigger to close the first channel. Since arm spacing and scan spacing are set to Immediate, the scan starts as soon as the scanner is taken out of the idle state by pressing the STEP key.

To run the test and store the readings in the Model 2002, press STORE on the multimeter, enter the desired number of readings (ten), and press ENTER. The Model 2002 waits (with the asterisk annunciator lit) for a Trigger Link trigger from the Model 7001/7002.

Press STEP on the Model 7001/7002 to start the scan. The scanner's output pulse triggers the Model 2002 to take a reading, store it, and send a trigger pulse. The following explanation on operation is referenced to the operation model shown in Figure 2-21.

(A) The BENCH RESET condition arms the Model 2002 and places multimeter operation at point A in the flowchart, where it is waiting for a Trigger Link trigger. Note that since both the arm layer and scan layer are programmed for Immediate Source, operation immediately drops down to the measure layer at point A.

(B) Pressing STEP takes the Model 7001/7002 out of the idle state and places operation at point B in the flowchart. Since both the arm layer and scan layer are programmed for Immediate Spacing, operation drops down to the channel layer at point B.

(C) Since Channel Trigger Source is set to Source, the scan does not wait at point B for a trigger. Instead, it bypasses "Wait for Trigger Link Trigger" and closes the first channel (point C). Note that the Bypass is in effect only on the first pass through the model into a layer.

(D) After the relay settles, the Model 7001/7002 outputs a Channel Ready pulse (point D). Since the instrument is programmed to scan ten channels, operation loops back up to point B, where it waits for an input trigger. Note that Bypass is no longer in effect.

(E) and **(F)** Remember that the Model 2002 operation is at point A waiting for a trigger. The output Channel Ready pulse from the Model 7001/7002 triggers the multimeter to measure DUT #1 (point E). After the measurement is complete, the Model 2002 outputs a completion pulse (point F) and then loops back to point A, where it waits for another input trigger.

The trigger applied to the Model 7001/7002 from the Model 2002 closes the next channel in the scan. This triggers the multimeter to measure the next DUT. The process continues until all ten channels are scanned and measured.

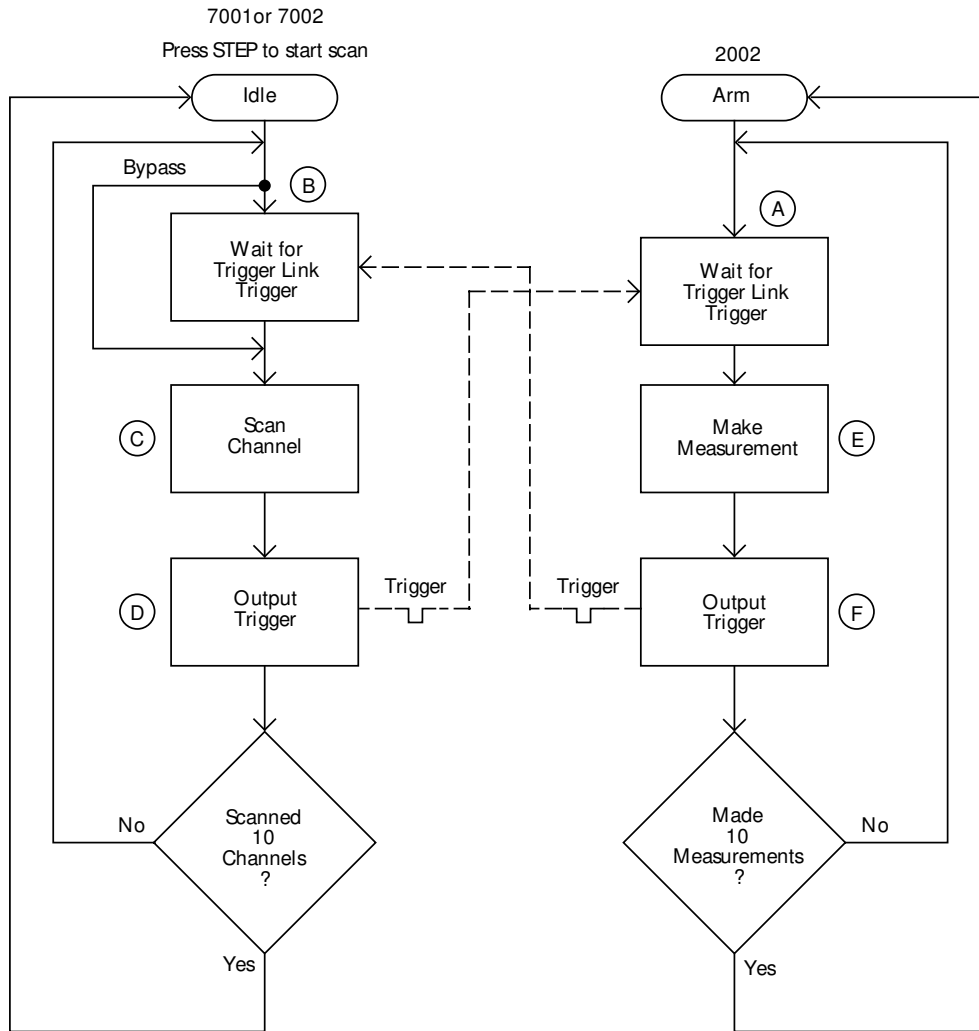

Figure 2-21
Operation model for asynchronous trigger link example #1

External Triggering and Trigger Link

As previously mentioned, the trigger pulses for the asynchronous Trigger Link are identical to the trigger pulses used for External Triggering. The only thing that prevents them from being used together in a test system is connection incompatibility. Trigger Link uses 8-pin micro-DIN connectors while External Triggering uses BNC connectors.

This connection problem can be solved by using the Model 8502 Trigger Link Adapter. The adapter has two 8-pin micro-DIN connectors and six BNC connectors. The micro-DIN connectors mate directly to the Trigger Link connector on the Model 2002 using a trigger link cable. The BNC connectors mate directly to the External Triggering BNC connectors on other instruments using standard male BNC to BNC cables.

Figure 2-22 shows how a Keithley Model 706 Scanner can be connected to the Trigger Link of the Model 2002 using the adapter. With this adapter, a Model 706 could be substituted for the Model 7001/7002 in the previous example (Asynchronous Trigger Link example #1). With the Model 706 set for External Triggering, the test would start when the single scan mode is selected and initiated.

Asynchronous Trigger Link example #2

In this example, the test system (Figure 2-23) includes a Model 2002 to measure each DUT at two different bias levels that are provided by a Model 230 voltage source. With the source set to the first voltage level, the ten channels are scanned and measured. The source is then set to the second voltage level and the ten channels are again scanned and measured.

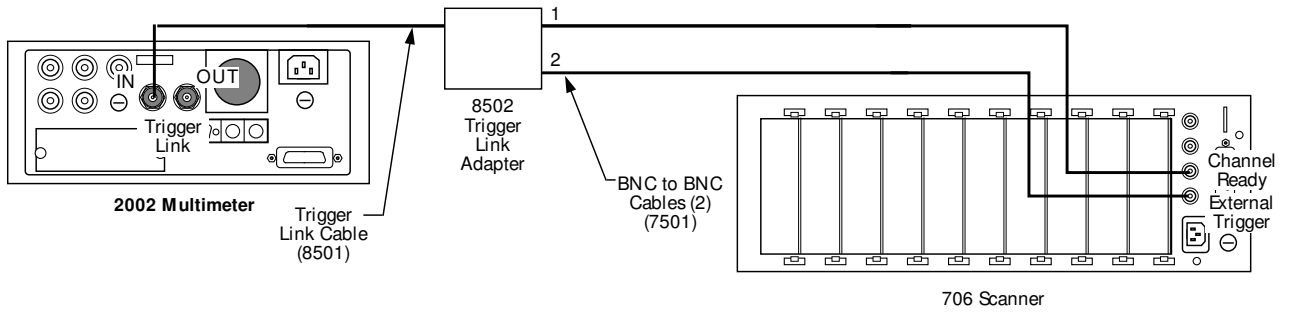

Figure 2-22
Connections using Trigger Link adapter

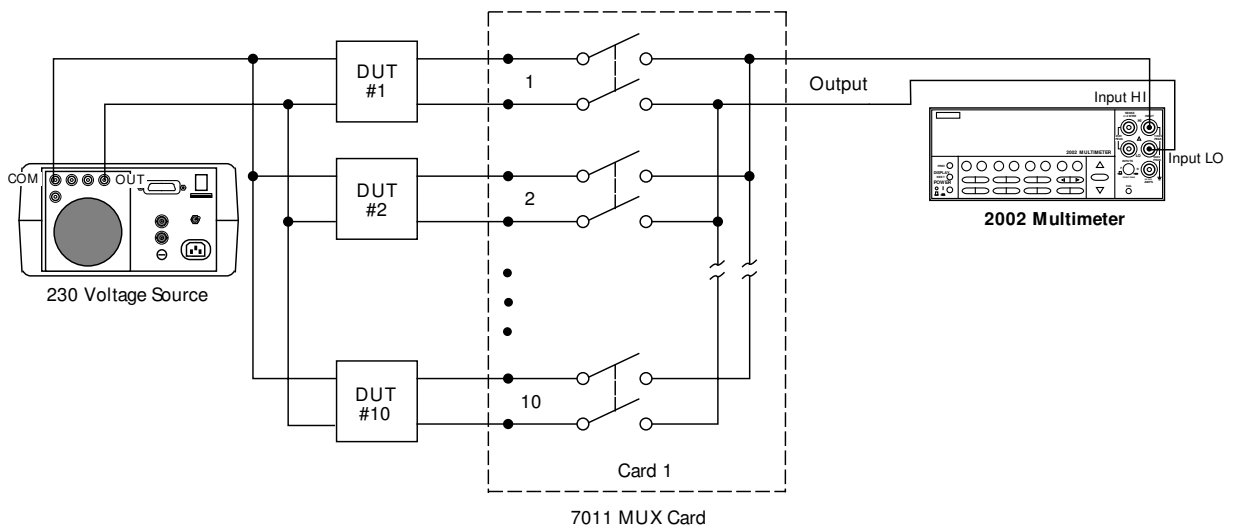

Figure 2-23
DUT test system (asynchronous example #2)

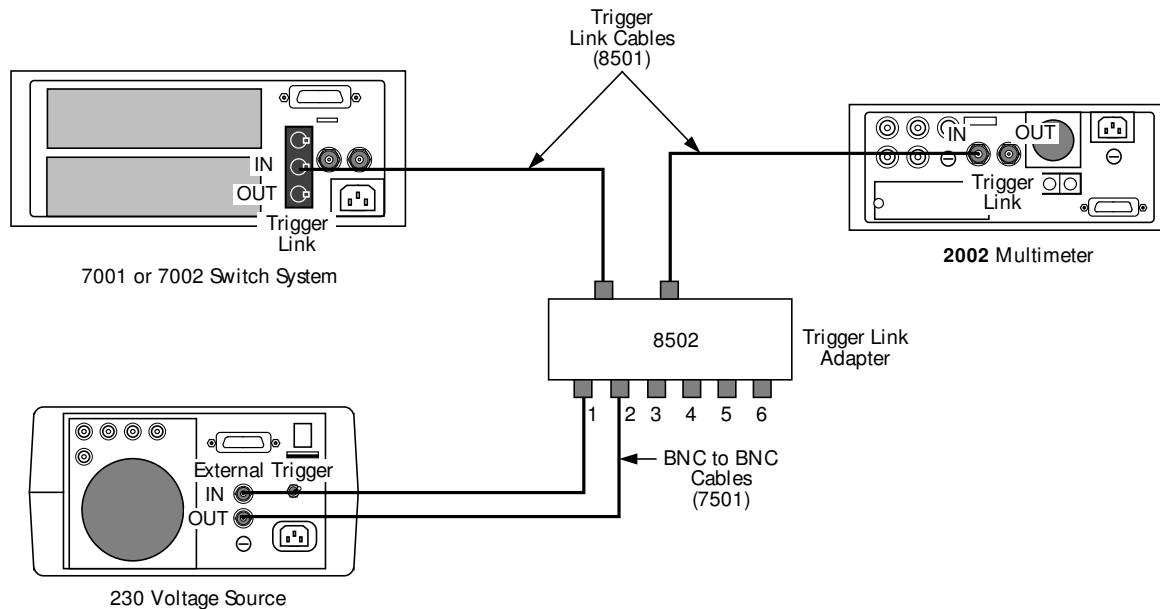

Figure 2-24
Trigger Link connections (asynchronous example #2)

Since this example uses an instrument that does not have Trigger Link (Model 230), the Model 8502 Trigger Link Adapter is required. Connections are shown in Figure 2-24.

For this example, the Model 230 is programmed for External Triggering and is set to source the first voltage level. The Models 2002 and 7001/7002 are configured as follows:

Model 2002:

Idle state:

Bench reset = :INIT:CONT ON*

Arm layer:

Arm source = Immediate*
Arm count = 1*
Arm trigger control = Acceptor*

Scan layer:

Scan source = Immediate*
Scan count = Infinite*
Scan trigger control = Acceptor*

Measure layer:

Measure source = TrigLink
Trigger link mode = Asynchronous
Input line = #3
Output line = #4
Measure count = 20
Measure trigger control = Acceptor*

* Indicates that the setting is the BENCH RESET (and factory) default condition.

Model 7001 or 7002:

Idle state:

Reset = :INIT:CONT OFF*

Scan list = 1!1-1!10,

Arm layer:

Arm spacing = Immediate*
Arm count = 1*
Arm trigger control = Acceptor*

Scan layer:

Scan spacing = TrigLink
Trigger link mode = Asynchronous
Input line = #2
Output line = #1
Number of scans = 2
Scan trigger control = Source

Channel layer:

Channel spacing = TrigLink
Trigger link mode = Asynchronous
Input line = #4
Output line = #3
Number of channels = 20
Channel trigger control = Source*

* Indicates that the setting is the RESET (and factory) default condition.

Notice that the Model 2002 is reset to BENCH defaults. With this selection, the multimeter stays armed. Since the arm source and scan source are set to Immediate, the Model 2002 waits in the measure layer for a trigger.

To run the test and store the readings in the Model 2002, press STORE on the multimeter, enter the desired number of readings (20), and press ENTER. The Model 2002 waits (with the asterisk annunciator lit) for a Trigger Link trigger from the Model 7001/7002.

Press STEP on the Model 7001/7002 to start the scan. The following explanation on operation is referenced to the operation model shown in Figure 2-25.

- Ⓐ Pressing STEP on the Model 7001/7002 takes it out of the idle state and places operation at point A in the flowchart. Since the arm layer is programmed for Immediate Spacing, operation drops down to the scan layer at point A.
- Ⓑ Since Scan Trigger Control of the Model 7001/7002 is set for Source, the scan does not wait at point A for a trigger. Instead, it bypasses “Wait for Trigger Link Trigger” and proceeds to point B. Note that this Bypass is in effect only on the first pass through the model.
- Ⓒ Since Channel Trigger Source of the Model 7001/7002 is also set to Source, the scan does not wait at point B for a trigger. Instead, it bypasses “Wait for Trigger Link Trigger” and closes the first channel (point C). Note that the Bypass is in effect only on the first pass through the model.
- Ⓓ After the relay settles, the Model 7001/7002 outputs a Trigger Link trigger pulse (point D). Since the instrument is programmed to scan ten channels, operation loops back up to point B, where it waits for an input trigger. Note that Bypass is no longer in effect.

- Ⓔ The trigger pulse from the Model 7001/7002 triggers the Model 2002 to make a measurement of DUT #1. After the measurement is complete, the multimeter outputs a Trigger Link trigger pulse (point E).

The trigger applied to the Model 7001/7002 from the Model 2002 closes the next channel in the scan, which in turn triggers the multimeter to measure the next DUT. This process continues until all ten channels are scanned and measured.

- Ⓕ After the last channel is scanned and measured, operation proceeds to point F, where the Model 7001/7002 outputs a trigger pulse. Since the Model 7001/7002 is programmed to perform two scans, its operation loops back up to point A, where it waits for an input trigger. Note that Bypass is no longer in effect.

- Ⓖ The trigger pulse from the Model 7001/7002 triggers the Model 230 to output the next programmed voltage level. After the voltage level is set, the Model 230 outputs a trigger pulse (point G).

The trigger pulse applied to the Model 7001/7002 from the Model 230 places operation at point B. The Bypass is again in effect because this is the beginning of a new scan. This allows operation to drop down to point C, where the first channel is again closed and eventually measured. As previously explained, all ten channels are scanned and measured.

After the last channel of the second scan is closed and measured, the Model 7001/7002 returns to the idle state.

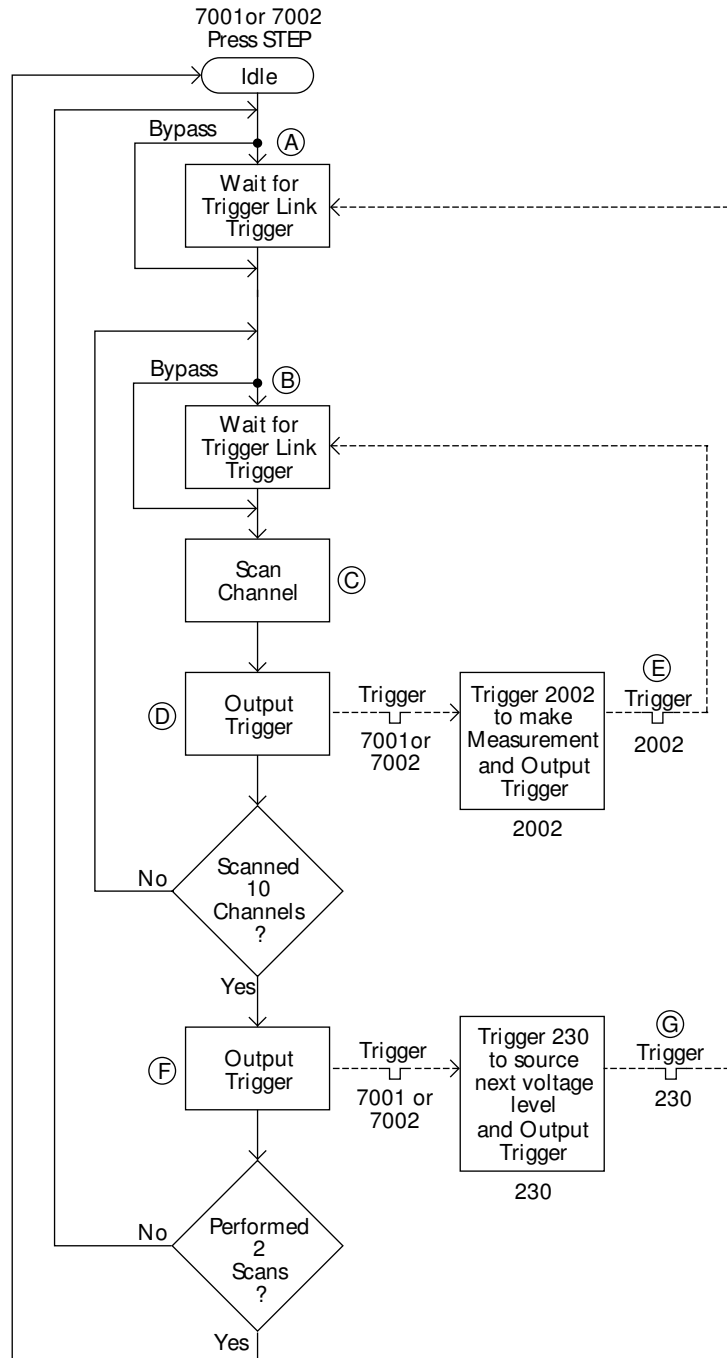

Figure 2-25
 Operation model for asynchronous Trigger Link example #2

Semi-synchronous operation

In the Semi-synchronous Trigger Link mode, all triggering (input and output) is controlled by a single line. When the normally high (+5V) trigger line is pulled low (0V), a trigger occurs on the negative-going edge. When the trigger line is released, a trigger occurs on the positive-going edge (see Figure 2-26). The advantage of this single line trigger is that as long as one of the instruments in the system holds the line low, the trigger is suppressed. In other words, the trigger does not occur until all instruments in the system are ready.

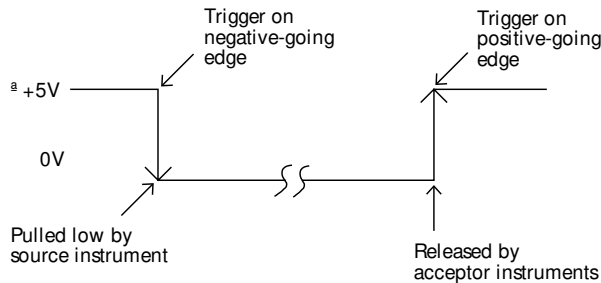

Figure 2-26
Semi-synchronous Trigger Link specifications

For example, assume that a Model 2002 is connected to two Model 7001 or 7002 Switch Systems for semi-synchronous operation, as shown in Figure 2-27. All three instruments are programmed to use trigger line #1. The two Model 7001s/7002s have relay settling times of 10msec and 50msec, respectively. The Model 2002 is designated as the trigger control source and the two Model 7001/7002 units as trigger control acceptors.

Assume that the Model 2002 initially performs a measurement. After the reading is done, the Model 2002 drives the trigger line low. The negative-going edge triggers both Model 7001s/7002s to close a channel. While the Model 7001s/7002s are in the process of closing a channel, they hold the trigger line low. Ten milliseconds after switch closure, the first Model 7001/7002 releases the trigger line. However, the second Model 7001/7002 continues to hold the line low since it is not finished. Fifty milliseconds after switch closure, the second Model 7001/7002 releases the trigger line. The positive-going edge triggers the Model 2002 to make a measurement and subsequently pull the trigger line back down to close the next channels. This process continues until all channels are scanned and measured.

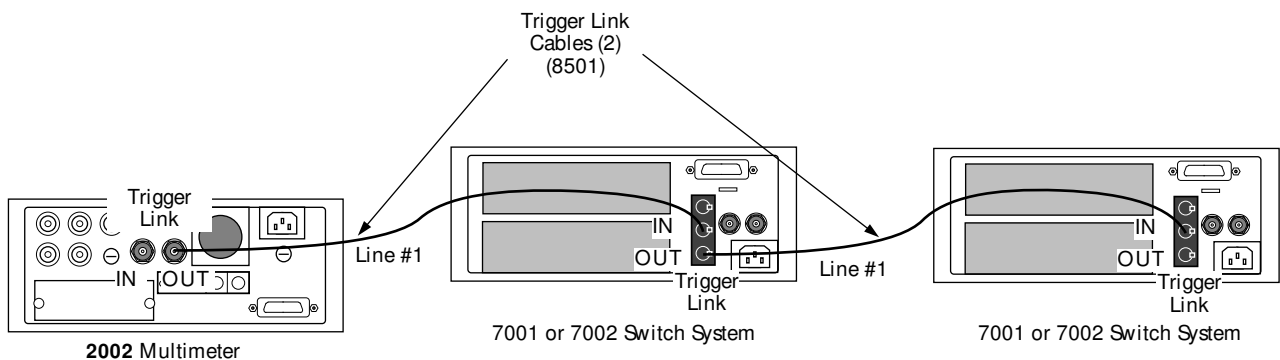

Figure 2-27
Typical semi-synchronous mode connections

Semi-synchronous Trigger Link example

This example uses the same test system (Figure 2-19) that was used for the Asynchronous Trigger Link example #1. However, triggering is done using the Semi-synchronous mode. Trigger Link connections are shown in Figure 2-28.

The two instruments are configured as follows:

Model 2002:

Idle state:

Bench reset = :INIT:CONT ON*

Arm layer:

Arm source = Immediate*

Arm count = 1*

Arm trigger control = Acceptor*

Scan layer:

Scan source = Immediate*

Scan count = Infinite*

Scan trigger control = Acceptor*

Measure layer:

Measure source = TrigLink

Trigger link mode = Semi-synchronous

Semi-sync line = #1*

Measure count = 10

Measure trigger control = Acceptor*

* Indicates that the setting is the BENCH RESET (and factory) default condition.

Model 7001 or 7002:

Idle state:

Reset = :INIT:CONT OFF*

Scan list = 1!1-1!10,

Arm layer:

Arm spacing = Immediate*

Arm count = 1*

Arm trigger control = Acceptor*

Scan layer:

Scan spacing = Immediate*

Number of scans = 1

Scan trigger control = Acceptor*

Channel layer:

Channel spacing = TrigLink

Trigger link mode = Semi-synchronous

Semi-sync line = #1

Number of channels = Use Scanlist length*

Channel trigger control = Source*

* Indicates that the setting is the RESET (and factory) default condition.

To run the test and store the readings in the Model 2002, press STORE on the multimeter, enter the desired number of readings (ten), and press ENTER. The Model 2002 waits (with the asterisk annunciator lit) for a Trigger Link trigger from the Model 7001/7002. Press STEP on the Model 7001/7002 to start the scan.

The following explanation on operation is referenced to the operation model shown in Figure 2-29.

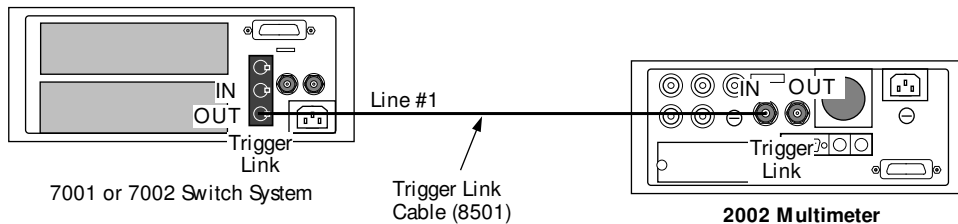

Figure 2-28
Trigger Link connections (semi-synchronous example)

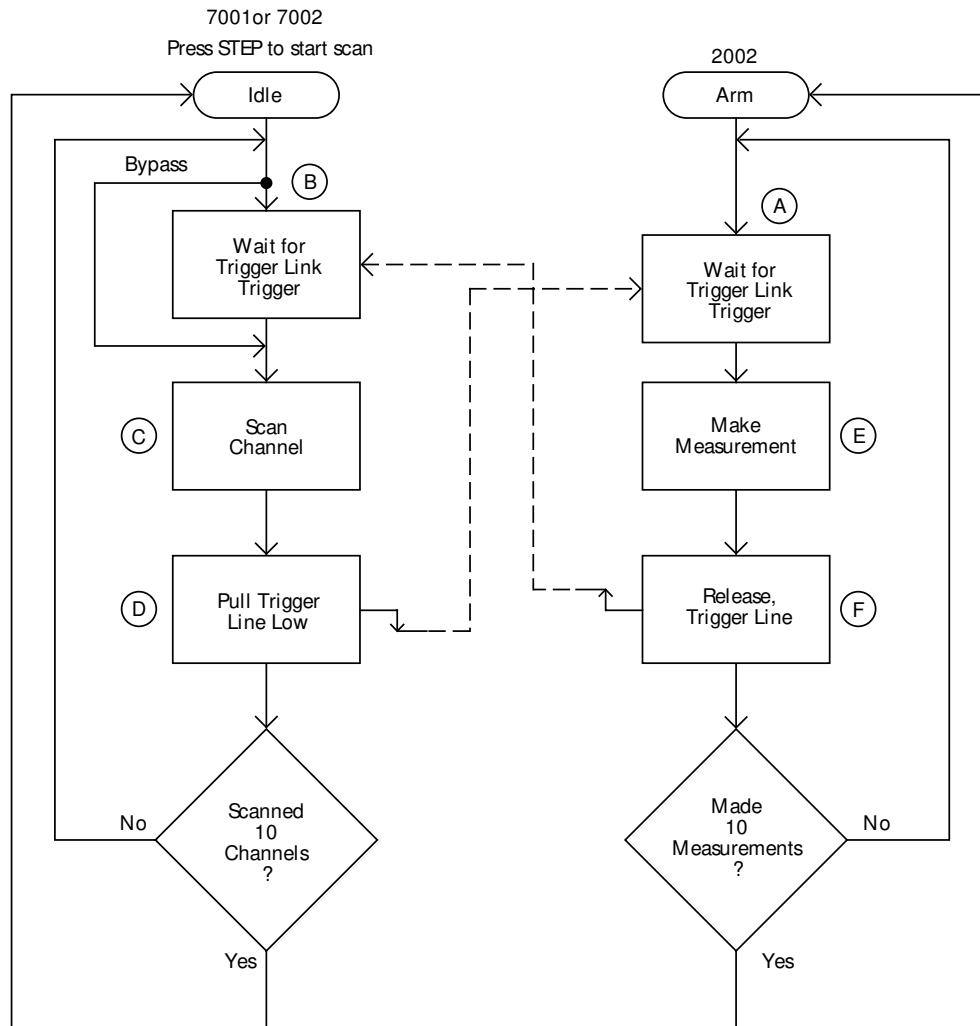

Figure 2-29
Operation mode for semi-synchronous Trigger Link example

- Ⓐ The BENCH RESET condition arms the Model 2002 and places multimeter operation at point A in the flowchart, where it is waiting for a Trigger Link trigger. Note that since both the arm layer and scan layer are programmed for Immediate Source, operation immediately drops down to the measure layer at point A.
- Ⓑ Pressing STEP takes the Model 7001/7002 out of the idle state and places operation at point B in the flowchart. Since both the arm layer and scan layers are programmed for Immediate Spacing, operation drops down to the Channel Layer at point B.
- Ⓒ Since Channel Trigger Source is set to Source, the scan does not wait at point B for a trigger. Instead, it bypasses “Wait for Trigger Link Trigger” and closes the first chan-

nel (point C). Note that the Bypass is in effect only on the first pass through the model.

- Ⓓ After the relay settles, the Model 7001/7002 pulls down the Trigger Link trigger line (point D). Since the instrument is programmed to scan ten channels, operation loops back up to point B, where it waits for an input trigger. Note that Bypass is no longer in effect.

- Ⓔ and Ⓕ Remember that the Model 2002 operation is at point A waiting for a trigger. When the trigger line is pulled low by the Model 7001/7002, the leading negative-going edge triggers the Model 2002 to measure DUT #1 (point E). Note that the multimeter holds the trigger line low. After the measurement is complete, The Model 2002 releases the trigger line (point F) and then loops back to point A where it waits for another input trigger.

When the Model 2002 releases the trigger line, the leading positive-going edge triggers the Model 7001/7002 to close the next channel in the scan. This pulls the trigger line low, triggering the Model 2002 to measure the next DUT. The process continues until all ten channels are scanned and measured.

2.8 Buffer

The Model 2002 has a buffer to store reading data. It can acquire readings at two different rates (normal and burst modes). The maximum possible number of stored readings depends on the installed memory option and the user-programmable data group. (See Table 2-28.)

Table 2-28
Reading storage options

Memory	Data group		
	Full	Compact	Type
Standard	404	2027	Volatile
MEM1 option	1381	6909	Non-volatile
MEM2 option	5980	29908	Non-volatile

A full data group includes the readings, units, channel#, reading#, time-stamp, and status (overflow). A compact data group does not include channel# or time-stamp information. In addition to these items, recalled data also includes statistical information, such as minimum, maximum, average, and standard deviation.

The following paragraphs discuss configuration of the buffer acquisition speed, data grouping, and buffer control, as well as recalling buffered data. The CONFIG DATA STORE menu structure is shown and summarized in Table 2-29.

Table 2-29
CONFIGURE DATA STORE menu structure

Menu item	Description
Burst-mode	Acquire 4.5-digit readings at 2000 readings/sec and store in buffer.
Data-group	Select data types to store in buffer.
Full	Store reading, units, channel#, reading#, time-stamp, and status (overflow).
Compact	Store reading, units, reading#, and status (overflow).
Control	Select type of buffer control.
Fill-and-stop	Fill buffer with readings and stop.
Pretrigger	Wait for pretrigger event; store before and after readings.
Percentage	Enter percentage of stored readings before trigger.
Reading-count	Enter count of stored readings before trigger.
Event	Select source for pretrigger event.
Continuous	Store readings in buffer continuously.
Never	Readings are not stored.
Timestamp	Configure timestamp:
Type	Check or change type:
Relative-Time	Reference timestamp to relative time.
Real-Time	Reference timestamp to real-time.
Format	Select timestamp format:
Absolute	Reference each timestamp to the first buffer reading (relative), or to the time and date (real).
Delta	Reference each timestamp to the previous buffer reading.
Clear-all	Clear all stored readings and buffer statistics.
Count	Select buffer size.
Enter-count	Enter number of readings to store.
Use-trigger-model	Use (finite) measure count from trigger model.
Feed	Select type of reading to store.
After-calc	Store readings after math calculation.
Before-calc	Store readings before math calculation.
None	No readings are placed in the buffer.

2.8.1 Burst mode

The burst data acquisition mode maximizes the reading rate of the Model 2002. Burst mode consists of two distinct phases:

- Acquiring raw readings (A/D counts).
- Post-processing the raw readings by applying calibration constants and storing the resulting readings in the buffer.

In burst mode, the Model 2002 acquires 4.5-digit readings at 2000 readings/second. The post-processing takes about 2msec/reading. If any filter or math operations are enabled, the post-processing time is longer. To make this reading rate possible, certain tradeoffs are made with the unit's functionality, as described in the following paragraph.

Configuring the unit for burst mode

Before burst mode can be enabled, the following changes must be made to the present instrument configuration:

- Select a valid measurement function for the burst mode, as listed in Table 2-30.
- Select a fixed range for the expected signal, or choose autorange to let the instrument select a fixed range when burst mode starts.
- Set the trigger event source in the measure layer to immediate, external, trigger link, or timer.
- Disable any "multiple displays".
- Disable scanning.

Table 2-30
Available functions in burst mode

Function	Type
DC voltage	Normal
AC voltage	RMS, average
DC current	Normal
AC current	RMS, average
2-wire resistance	Normal

If these changes are not made, a “Settings conflict” error or similar message is displayed when you attempt to turn on burst mode.

When burst mode is selected, the Model 2002 is automatically configured for taking fast measurements. (The instrument’s previous settings are restored when burst mode is aborted.) Selecting burst mode makes these temporary changes:

- Triggers are idled between bursts.
- Autoranging is disabled.
- Autozero is disabled.
- Integration time is set to 0.01 PLC (167µsec).
- Resolution is fixed at 4.5 digits.
- Buffer data group is set to compact.
- Buffer control is set to fill-and-stop.

NOTE

Some instrument settings allowed in burst mode, such as a trigger event source of timer in the measure layer, may affect the acquisition speed of 2000 readings/second.

Enabling burst mode

Once burst mode is enabled, the instrument is dedicated to that purpose. Other than setting the buffer size, you cannot change any configuration parameters until burst mode is aborted.

Thus, make sure to configure the instrument’s function, range and triggering to be compatible with burst mode before enabling it. An incompatible configuration causes a “Settings conflict” error when you try to enable burst mode.

Burst mode is enabled through the CONFIG DATA STORE menu. This menu is displayed by pressing CONFIG and

then STORE. Rules for navigating menu structures are provided in paragraph 2.3.4.

BURST-MODE

This CONFIG DATA STORE menu selection is used to enable or disable the burst mode:

OFF: Selecting this menu item returns the instrument to the CONFIG DATA STORE menu.

ON: Select ON to enable burst mode. This action clears the buffer, puts the unit into idle and takes it out of autorange. The following typical message then prompts you for the number of readings to store in the buffer:

BURST: 00100 READINGS

After ENTERing the desired buffer size, the following typical message will be displayed:

00100 READING BURST
Use TRIG to start; EXIT to abort

Burst mode operation

Table 2-31 details the sequence of steps during burst mode. The steps assume just one burst of readings before aborting the burst mode, but you are able to initiate more than one burst, each time overwriting the previously stored readings.

As can be seen from the table, a front panel trigger starts the burst acquisition. The Model 2002 remains looping in the measure layer of the trigger model until the requested number of readings is acquired. To enhance burst acquisition speed, the front panel is not updated until the raw readings are being post-processed.

Meter Complete output pulses are sent at the rate of 2kHz during the acquisition phase. (Note: The last one is not sent until post-processing is done.)

After the acquisition phase, the unit returns to the idle state and starts post-processing, which consists of converting the raw readings into measurements by applying the calibration constants. During the post-processing phase, the front panel “*” annunciator is lit.

The acquisition phase of burst mode can be aborted by pressing the EXIT key. Then the Model 2002 starts post-processing on that portion of the reading buffer.

Since burst mode turns off autozero, an autozero refresh is required once every 24 hours (by changing functions, resolution, or issuing an autozero bus command).

Table 2-31
Burst mode sequence

Action	Result	Annunciators
BURST MODE ON ENTER	BURST:00100 READINGS Use ◀, ▶, ▲, ▼, ENTER, EXIT, or INFO	ARM and AUTO off
ENTER	00100 READING BURST Use TRIG to start; EXIT to abort	ARM on
TRIG	(burst readings acquired)	
	(post-processing of readings)	* on
	BURST:00100 READINGS Processing rdg #xx of 1000	
	BURST:00100 READINGS Storage complete; press RECALL	ARM and * off
RECALL	BURST:00100 READINGS Use ◀, ▶, ▲, ▼, ENTER, EXIT, or INFO Rdg#+00000	
	...	
	Rdg#+00099	
EXIT	BURST:00100 READINGS Use ◀, ▶, ▲, ▼, ENTER, EXIT, or INFO	
	(press ENTER to loop back to start)	
EXIT	BURST MODE ABORTED Use CONFIG → STORE to resume	ARM and AUTO on
	(normal reading display)	

Notes:

1. This table assumes the unit was set for autorange before enabling burst.
2. Multiple displays of buffered readings are available when burst data is recalled. (See paragraph 2.5.4.)

2.8.2 Configuring data storage

The data storage configuration menu is used for the following operations:

- To acquire a burst of readings at high speed.
- To select the data types stored in the buffer.
- To select the buffer control.
- To clear the buffer of readings and statistics.
- To specify the number of readings to store.
- To specify the source of readings to be stored.

The buffer is configured from the CONFIG DATA STORE menu (see Table 2-29). This menu is displayed by pressing

CONFIG and then STORE. Rules for navigating menu structures are provided in paragraph 2.3.4.

BURST-MODE

The burst mode is discussed in paragraph 2.8.1.

DATA-GROUP

This menu selection chooses the data items that are stored in the buffer. Note that changing the data grouping clears the buffer.

FULL: With this selection, for each reading, the following information is stored: units, channel number (if applicable), reading number, time-stamp, and status (overflow).

The “full” data group should be used for 6.5 digits or greater resolution. It also allows you to change function, range, or channel while storing.

COMPACT: With this selection, readings, units, reading numbers, and status (overflow) are stored. This allows more readings to be stored in the buffer.

“Compact” is only accurate and displayed to 5.5 digits. It does not allow changes of function, range, or channel while storing.

CONTROL

This menu item controls the type of data storage.

FILL-AND-STOP: This control selection fills the buffer with the requested number of readings and stops. You can then recall the readings.

PRETRIGGER: This selection continuously stores readings until a user-programmed trigger event occurs. It then stores post-trigger readings. For example, with a buffer size of 100 readings, there will be 50 readings stored before the trigger event and 50 readings stored after the trigger.

The first reading after the trigger is reading zero. Pretrigger readings have reading numbers and relative time-stamps with a minus sign; post-trigger readings have reading numbers and relative time-stamps with a plus sign.

After selecting PRETRIGGER, configure pretrigger control further as follows:

- **PERCENTAGE** or **READING-COUNT** — Specify the number of readings to store before the trigger event as a percentage of the total number of stored readings, or as a number of pretrigger readings. You will be prompted to enter the percentage or count value.
- **EVENT** — Selects the source of the pretrigger or “mark-point” event. This can be a Manual, GPIB, Trigger Link or External trigger.

CONTINUOUS: With this control selection, readings are always stored in the buffer. The process continues, with the oldest readings being overwritten in a circular manner, until storage is interrupted with the EXIT key.

NEVER: Gets set to this if data storage has been interrupted. Pressing the STORE key changes NEVER to FILL-AND-STOP.

CLEAR-ALL

This action can be used at any time to clear the data buffer of all stored readings and buffer statistics. Since the MEM1 and MEM2 memory options are non-volatile, clear-all is the only way for the operator to clear the reading buffer.

TIMESTAMP

When using FULL data grouping (see DATA-GROUP), a timestamp is included with each buffer reading. This menu selection is used to check and/or change the timestamp type and format.

TYPE: This menu item is used to check and/or change the timestamp type. Note that changing the timestamp type clears the buffer.

- **RELATIVE-TIME** — With this selection, timestamps are oriented to a timer with the first buffer reading timestamped at 0.000000 seconds. Each following timestamp is then based on the currently selected format (see FORMAT). With the ABSOLUTE format selected, the timestamp for each reading is referenced (in seconds) to the first buffer reading. With the DELTA format selected, each timestamp is referenced (in seconds) to the previous timestamp.
- **REAL-TIME** — With this selection, timestamps are oriented to the real-time clock and are based on the currently selected format (see FORMAT). With the ABSOLUTE format selected, each reading is simply timestamped with the actual time and date. Time can be expressed in the 12-hour (AM, PM) format or the 24-hour format (see CLOCK in paragraph 2.12.7).

With the DELTA format selected, the first buffer reading is timestamped at 00000d 00h 00m 00.00s (zero days, hours, minutes and seconds). Each subsequent timestamp is referenced (in days, hours, minutes and seconds) to the previous timestamp.

Timestamp type for buffer readings is coupled to timestamp type for bus readings. Thus, if you change timestamp type from this menu structure, it also changes in the MAIN MENU structure (see TIMESTAMP in paragraph 2.12.7).

FORMAT: This menu item is used to check and/or change the timestamp format. Note that if format is changed after readings are stored in the buffer, the timestamps will change to reflect the alternate format.

- **ABSOLUTE** — With this selection, each timestamp provides the time and date that the reading was taken (see REAL-TIME timestamp type), or the number of seconds from the first buffer reading that the reading was taken (see RELATIVE-TIME timestamp type).

- **DELTA** — With this selection, each timestamp is referenced to the timestamp for the previous reading. This provides the time between buffer readings. Timestamps are provided in days, hours, minutes and seconds (see REAL-TIME timestamp type) or in seconds (see RELATIVE-TIME timestamp type).

COUNT

With this menu selection, you specify the number of readings to store.

ENTER-COUNT: This item allows you to specify the buffer size in number of readings.

USE-TRIGGER-MODEL: This selection lets you default to the measure count in the present trigger configuration, as long as the measure count is a finite value.

FEED

This selection allows you to select the source of readings to be placed in the buffer.

AFTER-CALC: With this item, readings are stored in the buffer after any enabled math operations are performed.

BEFORE-CALC: With this item selected, readings are placed in the buffer before any math is performed.

NONE: With NONE selected, no readings are placed in the buffer when storage is performed. Pressing the STORE key changes NONE to the AFTER-CALC selection.

2.8.3 Storing and recalling readings

Tables 2-32 through 2-34 detail the sequence of steps for the various modes of buffer control. The tables assume the buffer is configured as explained in paragraph 2.8.2.

Note that during data storage, the reading number on the bottom line of the display is one ahead of the reading on the top line.

There are “multiple displays” available when recalling buffered readings. These are explained in paragraph 2.8.4.

*Table 2-32
Fill-and-stop sequence*

Action	Result	Annunciator
STORE ENTER	STORE 00100 READINGS Storing reading #xx of 100 Storage complete; press RECALL	(* on) (* off)
RECALL	Rdg#+00000 @Time=+000.000000 sec ... Rdg#+00099 @Time=+002.700473 sec	
EXIT	(normal reading display)	

Table 2-33
Continuous sequence

Action	Result	Annunciator
STORE ENTER	STORE 00100 READINGS Storing reading #xx of 100	(* on)
RECALL	100 rdgs stored; continuous ON Rdg#+00000 @Time=+003.903546 sec ...	
EXIT RECALL	100 rdgs stored; continuous ON Rdg#+00000 @Time=+067.709331 sec ...	
EXIT EXIT	100 rdgs stored; continuous ON STORAGE INTERRUPTED Acquired 100 of 100 readings (normal reading display)	(* off)

Table 2-34
Pretrigger sequence

Action	Result	Annunciator
STORE ENTER	STORE 00100 READINGS Waiting for pretrigger event	(* on)
TRIG	Storing reading #xx of 50	
RECALL	Storage complete; press RECALL Rdg#-00050 @Time=-004.999990 sec ... Rdg#+00000 @Time=+000.000000 sec ... Rdg#+00049 @Time=+004.899996 sec	(* off)
EXIT	(normal reading display)	

Note: A manual trigger is used as an example. Other pretrigger events include GPIB, trigger link, and external.

2.8.4 Buffer multiple displays

Math operations performed on buffered readings are available when readings are recalled. Just press NEXT DISPLAY to view the math operation on the bottom line of front panel display, in the following order:

1. MAX — maximum reading in buffer, for example:
MAX=+1.635968e+00 at RDG# +00090

Notes:

- A. Display response may be slow due to calculation of statistics for large buffers.

- B. Exponents are in terms of primary units of function on top line (i.e., volts, not millivolts).
2. MIN — minimum reading in buffer, for example:
MIN=+1.627611e+00 at RDG# +00012
3. AVG — This math operation displays the mean value of the buffered readings, for example:
AVG=+1.6345e+00

The equation used to calculate the mean is:

$$y = \frac{\sum_{i=1}^n X_i}{n}$$

where: x_i is a stored reading, and
 n is the number of stored readings.

Note: If $n = 0$, the result is NAN (not a number).

4. SDEV — This operation displays the standard deviation of the stored readings, for example:

SDEV=1.4944e-03

The equation used to calculate the standard deviation is:

$$y = \sqrt{\frac{\sum_{i=1}^n X_i^2 - \frac{1}{n} \left(\sum_{i=1}^n X_i \right)^2}{n-1}}$$

where: x_i is a stored reading, and
 n is the number of stored readings.

Note: If $n \leq 1$, the result is NAN (not a number).

NOTE

These statistics are invalid if the measurement function changed during data store (e.g., when scanning different functions).

The Model 2002 uses IEEE-754 floating point format for math calculations.

The last display in this series allows you to dump the buffered readings to a printer. See paragraph 2.12.2 for details on configuring printers.

2.9 Filter

Filtering stabilizes noisy measurements. The Model 2002 uses a digital filter, which is based on reading conversions. The displayed, stored, or transmitted reading is simply an average of a number of reading conversions.

When a filter is enabled, the selected filter configuration for that measurement function is in effect. Filtering is enabled

by pressing the FILTER key (FILT annunciator turns on). Pressing FILTER a second time disables the filter.

Filtering is performed only on primary display measurements; it has no effect on multiple displays.

2.9.1 Filter types

The Model 2002 has two types of digital filters: averaging and advanced. Both types are a simple average of one to 100 reading conversions. The difference between them is the user-programmable noise “window” of the advanced filter.

The noise window, which is expressed as a percentage of range (0-100%), allows a faster response time to large signal step changes (e.g., scanned readings). A reading conversion outside the plus or minus noise window fills the filter “stack” immediately.

If the noise does not exceed the selected percentage of range, the reading is based on an average of reading conversions. In this case, the advanced filter works the same as the averaging filter. If the noise does exceed the selected percentage, the reading is a single reading conversion, and new averaging starts from this point. The two filter types are compared in Figure 2-30.

2.9.2 Filter modes

An additional filter parameter is the mode, either moving or repeating. A moving filter is a first-in, first-out stack, where the newest reading conversion replaces the oldest. An average of the stacked reading conversions yields a reading. Therefore, after a selected number of conversions, a moving filter gives a new reading for every new conversion.

A repeating filter takes a selected number of reading conversions, averages them, and yields a reading. It then flushes its stack and starts over. This characteristic is useful when scanning channels.

If burst mode is enabled with filtering, the post-processing time increases. A filter mode setting of repeating is ignored in burst mode.

Filter modes are compared in Figure 2-31.

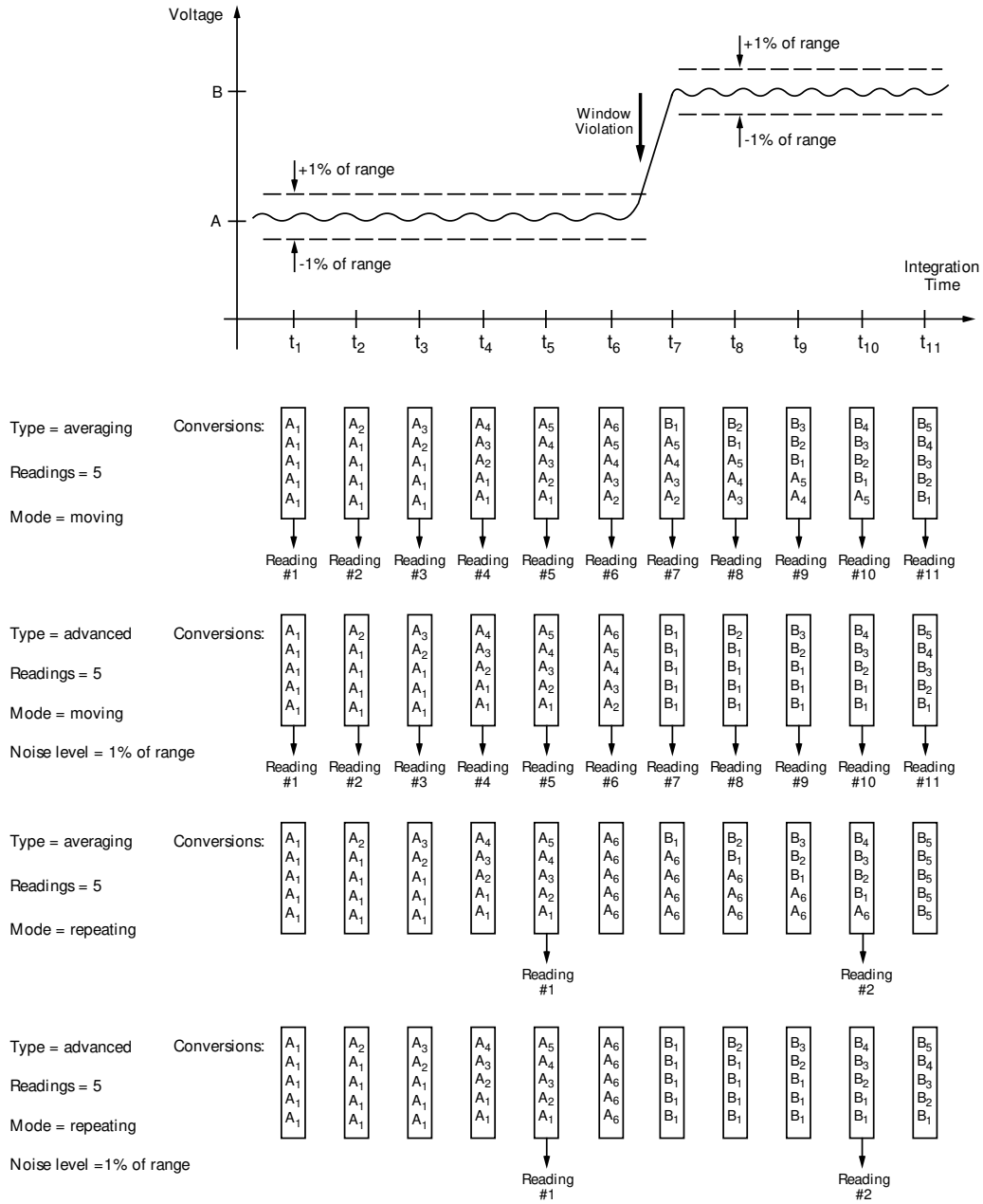
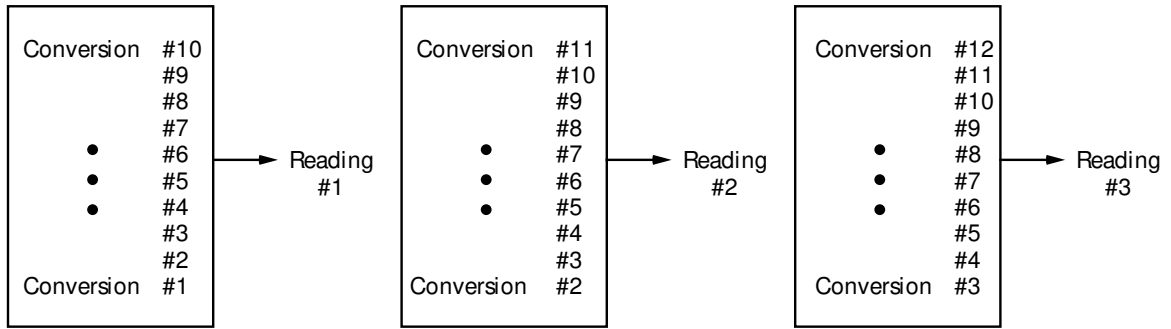
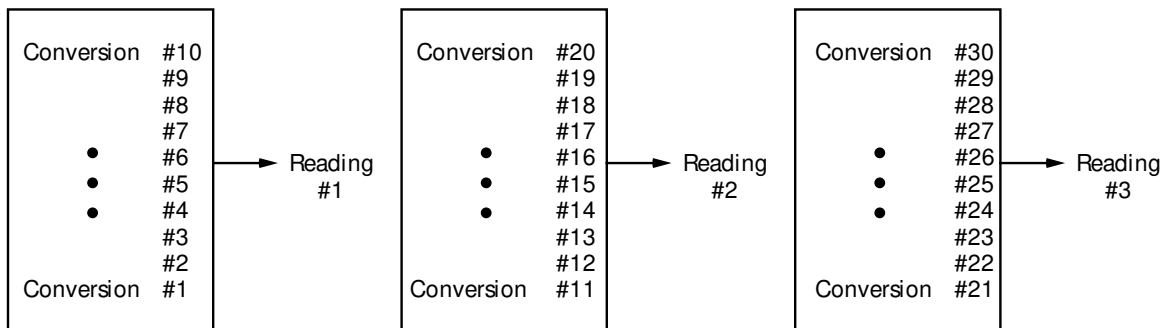

Figure 2-30
Averaging and advanced filter types



A. Type - Average, Readings = 10, Mode - Moving



B. Type - Average, Readings = 10, Mode - Repeating

Figure 2-31
Moving and repeating filter modes

2.9.3 Response time

The various filter parameters have the following effects on the time needed to display, store, or output a filtered reading:

- Filter type: The time to the first reading is the same for both types, but thereafter averaging mode yields a faster reading than repeating mode. Also, advanced has a faster response to changes in the input signal than averaging.
- Number of reading conversions: Speed and accuracy are tradeoffs.

- Noise window: For the advanced type, a tradeoff of speed, accuracy, and response to input signal changes.

2.9.4 Auto filtering

For those measurement functions with a filter, one of the possible selections is automatic filtering. Depending on the measurement function and type, the AUTO selection may disable filtering. Auto filtering is summarized in Table 2-35.

Table 2-35
Auto filters

Measurement		Filter				
Function	Type	State	Type	Readings	Averaging Mode	Noise Tolerance Level
DC voltage	--	On	Advanced	10	Moving	1%
AC voltage	RMS, average, low frequency RMS	Off	Advanced for volts; Average for dB, dBm	10	Moving	5%
	Peak, pos. peak spikes, neg. peak spikes	On	Advanced for volts; Average for dB, dBm	10	Moving	5%
DC current	Normal	On	Advanced	10	Moving	1%
	In-circuit	On	Advanced	10	Moving	1%
AC current	RMS, average	Off	Advanced	10	Moving	5%
2-wire resistance	--	On	Advanced	10	Moving	1%
4-wire resistance	--	On	Advanced	10	Moving	1%
Frequency	--	(See note)				
Temperature	--	On	Average	10	Moving	-

Note: A filter is not available on the frequency function.

2.9.5 Configuring the filters

Each measurement function except frequency has its own configuration for a digital filter. A digital filter configuration menu is shown in Table 2-36.

Table 2-36
CONFIGURE FILTER menu structure

Menu item	Description
Auto	Default to filter appropriate for measurement function and type.
Averaging	Program simple average filter (1-100 readings).
Advanced	Program simple average filter (1-100 readings), with a noise tolerance window (0-100% of range).
Averaging-mode	Select moving average or repeating average mode.

Choosing the filter parameters for each function follows the same procedure. There are three ways to display a filter configuration menu:

- To configure the filter of the present function, just press CONFIG, then FILTER.
- To configure the filter of another function and remain in the present function, press CONFIG, and the appropriate function key, then select FILTER from its menu.
- To configure the filter of another function and change to that function, press the appropriate function key, and CONFIG, then FILTER.

AUTO

This menu item selects auto filtering. When chosen, auto filtering enables the filter parameters listed in Table 2-35 for the function you are presently configuring. Note that selecting AUTO immediately enables the filter for that function when the state listed in Table 2-35 is ON. In this case, if you are configuring the filter for the present measurement function, the FILT annunciator comes on.

AVERAGING

Use this selection for a non-windowed averaging filter. A message indicating the presently set number of reading conversions to average (the “stack” size) is displayed. If you change the filter value, be sure to press ENTER.

Note that the number of reading conversions selected for the averaging filter type is also coupled to that for the advanced filter type.

ADVANCED

This selection is for an averaging filter with a noise window. (It is not available with dB or dBm units, ratio or delta, temperature or frequency.) A message indicating the presently set number of reading conversions to average (the “stack” size) is displayed.

You can retain the present filter value or you can key in another value. In either case, press ENTER to display the maximum noise window.

The displayed level is the plus or minus percentage of range window around the first reading conversion in the stack. Be sure to press ENTER if you key in a different percentage.

Note that the number of reading conversions (filter value) selected for the advanced filter is also coupled to that for the averaging filter.

AVERAGING-MODE

This selection determines the mode of a digital filter for a measurement function, either a moving or repeating average.

MOVING: This item selects a moving filter, where a new reading conversion is shifted into a stack as the oldest conversion is shifted out (FIFO). When the stack is full, a simple average is taken to yield a reading.

REPEAT: This menu item selects a repeating filter, where an average of a selected number of reading conversions is taken for each reading.

2.10 Math

Model 2002 math operations are divided into four categories:

- Math performed on single readings (polynomial percent, and percent deviation).

- Math performed on buffered readings (maximum and minimum values, average, and standard deviation).
- Math performed on single readings as a part of a pass/fail limits test.
- Math performed on scanned readings (ratio and delta).

The first category is configured from the CONFIGURE MATH menu and is described in this paragraph. Math operations on buffered readings are available in multiple displays of recalled data and are discussed in paragraph 2.8. Limit tests are described in paragraph 2.12, under main menu operations. Ratio and delta calculations on scanned channels are available from the CONFIGURE SCAN menu, as discussed in paragraph 2.11.

Note that once enabled for a function, the polynomial and the percentage calculations are in effect across function changes.

NOTE

The Model 2002 uses IEEE-754 floating point format for math calculations.

2.10.1 Polynomial

This math operation allows you to mathematically manipulate normal display readings (X) according to the following polynomial calculation:

$$Y = (a2)X^2 + (a1)X + (a0)$$

where: X is the normal display reading
a2, a1 and a0 are user entered constants
Y is the displayed result

The value of the “a2”, “a1” and “a0” constants can be changed through the CONFIGURE MATH menu (see paragraph 2.10.4). The before and after calculation can be viewed with one of the multiple displays, as described in paragraph 2.10.5. When necessary, the resulting Y value is displayed in scientific notation.

The polynomial can be used in place of the more familiar $mX+b$ slope calculation. Simply let $a2=0$, $a1=m$ and $a0=b$. Over the bus, the $mX+b$ calculation still exists and is coupled to the polynomial calculation. Thus, changing a1 and/or a0 changes m and/or b respectively. See paragraph 3.11 for details.

2.10.2 Percent

This operation lets you specify a target reading value. The displayed reading will be expressed as a percentage of the target value, often in scientific notation. The percentage calculation is performed as follows:

$$\text{Percent} = \frac{\text{Input Reading}}{\text{Target Value}} \times 100$$

As an example, consider the default target value for percentage calculations, where:

$$100\% = +1.000000e+00$$

Therefore, on the 200µA range, a 100µA input would be 0.01% of the target value and a typical reading would be displayed as follows:

$$+1.0000e+04\mu\text{AAC}\%$$

Range: 200 µAAC Coupling: AC

Note that the value is not 10000%, but 10000µ%, which equals 0.01%. With the calculate multiple display selected, as described in paragraph 3.10.5, the display would be:

$$+1.0000e+04\mu\text{AAC}\%$$

Reading = +100.000

where the bottom line shows the reading (in the units and multiplier prefix of the top line) before the percentage calculation is performed.

2.10.3 Percent deviation

The following math calculation provides the percent deviation between the normal display reading and the currently stored REL value for the selected function:

$$\text{PD} = \frac{(X-Y)}{Y} \times 100\%$$

where: X is the normal display reading
 Y is the REL value for the selected function
 PD is the displayed result (percent deviation)

Percent Deviation is enabled through the CONFIGURE MATH menu (see paragraph 2.10.4).

Note that Percent Deviation does not scale based on the m, k, or M range factor. For example, 10% deviation on the 20kΩ range will be displayed as 10.00000. If the number is too large for the allowed number of leading zeroes (for example 10 on the 2kΩ range), the display will switch to 7-1/2 digit scientific notation.

2.10.4 Selecting and configuring math

The polynomial, percent or percent deviation calculation is selected and configured from the CONFIGURE MATH menu (see Table 2-37). The selected calculation is enabled by pressing the MATH key. The Model 2002 then displays the result of the calculation, using scientific notation where necessary. Pressing MATH a second time disables the calculation.

Table 2-37
 CONFIGURE MATH menu structure

Menu item	Description
None	Select no calculation when MATH key is pressed.
Polynomial	Select polynomial calculation and enter constants.
Percent	Select percent calculation and enter target (reference) value.
Percent deviation	Select percent deviation calculation.

NONE

With this menu item, no math operation goes into effect when the MATH key is pressed. The MATH annunciator lights, but NONE is displayed on the top line.

POLYNOMIAL

This menu item selects the polynomial calculation and allows you to program the polynomial constants. The “a2” constant is displayed first. You can retain the displayed value or key in a new value. In either case, press ENTER to display the “a1” constant. Retain or change this constant and press ENTER to display the “a0” constant. If you change the “a0” constant, be sure to again press ENTER.

PERCENT

This menu item selects the percent calculation and lets you specify the target value. If you key in a new target value, be sure to press ENTER.

PERCENT DEVIATION

This menu item selects the percent deviation calculation and returns the display to the normal measurement state.

2.10.5 Calculate multiple display

One of the multiple displays lets you view the reading on the bottom line of the display and the result of the calculation on the top line. This display is available by repeatedly pressing either the NEXT or PREVIOUS DISPLAY key to scroll through the multiple displays for the particular function. The following is a typical message for a percentage calculation:

```
-7.0431e+01 VDC %
Reading = -0.704311
```

The display resolution on the bottom line follows that chosen for the top line. If scientific notation is required on the top line, it is fixed at 4.5 digits. The value on the bottom line tracks the units and prefix of the top line. (For example, if the top line displays μA , then the units on the bottom line are μA .)

Note that this multiple display is not available on the frequency function.

2.11 Scanning

The Model 2002 can be used with an internal scanner card (Model 2001-SCAN or 2001-TCSCAN) or with external scanner cards installed in switching mainframes such as the Models 706, 7001 and 7002. The following paragraphs discuss various aspects of using scanning with the Model 2002.

2.11.1 Scanning overview

A scanner allows you to switch among a number of input signals to the Model 2002 for measurement. The channel control and scanning capabilities depend on whether an internal or external scanner card is being used, as well as on the capabilities of the scanner card in question. Refer to the documentation supplied with the scanner card for specific connection information.

Using an internal scanner card

The optional Model 2001-SCAN scanner card allows you to switch or scan up to ten 2-pole channels, or five 4-pole channels. Two of the channels use solid-state switching for high-speed multiplexing, ratio, or delta applications.

The optional Model 2001-TCSCAN Thermocouple/General Purpose Scanner Card allows you to multiplex one of nine 2-pole, or one of four 4-pole analog signals into the Model 2002, and/or any combination of 2- or 4-pole analog signals. Refer to the instruction manual for the Model 2001-TCS-CAN for complete operation information.

When using these cards, the Model 2002 can:

- Close and open individual channels.
- Scan through channels using a separate measurement function for each channel, if desired.
- Perform ratio and delta measurements using two user-defined channels.

Using external scanner cards

When using external scanning, you can define separate measurement functions for a maximum of 80 channels. Note however, that you cannot close or open external channels using Model 2002 controls. Use the switching mainframe controls to open and close individual channels.

In order to synchronize Model 2002 measurements with external channel closure, connect the Model 2002 external trigger inputs or the trigger link to the external switching mainframe trigger inputs and outputs. Refer to paragraphs 2.7.6 and 2.7.7 for examples on using external triggering and the trigger link.

2.11.2 Front panel scanner controls

Controls that affect scanner card operation include:

- CHAN: Allows you to open and close internal scanner card channels.
- CONFIGURE CHAN: Defines the measurement functions for each internal and external scanner card channel, selects the number of external channels, defines channels assigned to the internal scan list, and saves/restores an alternate measurement function.
- CONFIGURE SCAN: Selects internal or external scanning and controls ratio/delta operation when using the internal scanner.
- SCAN: Starts/stops scanning using the selected scan list. Configures scan count, scan interval, and enables buffer storage and recall if internal or external list is selected.
- EXIT: Disables scanning and returns to normal operation. (Trigger model is restored to pre-scanning configuration.)
- ◀ and ▶ : Allows you to manually scan through channels.
- PREV/NEXT DISPLAY: Allows you to display the two adjacent channels (manual scanning only).

2.11.3 Using CHAN key to close and open internal channels

The CHAN key controls channels on the internal scanner card only. The CHAN key allows you to directly:

- Close a specific channel (or channel pair for 4-wire functions).
- Immediately open any internal closed channel (or channel pair for 4-wire functions).

Channel selection menu

Table 2-38 summarizes the channel selection menu structure along with a brief description of each item. More detailed descriptions of these menu items are presented in the following paragraphs. See paragraph 2.3.4 for general rules on navigating menus.

With a scanner card installed in the option slot of the Model 2002, the following options are available when CHAN is pressed:

CLOSE-CHANNEL: This menu item prompts you to enter the channel (from 1 to 10) that you wish to close. Use the cursor keys (◀ and ▶) and the RANGE ▲ and ▼ keys to display the channel and press ENTER. The number of the closed channel will be displayed on the front panel along with normal readings.

Selecting a different channel from the one that is presently closed will cause the closed channel to open and allow a settling time before closing the selected channel.

Channel relays will be closed according to the presently selected function. If a 2-wire function is used, only the relay for that one channel will be closed. If a 4-wire function is selected, both the selected channel relay and the matching relay pair will close. For example, closing channel 2 will also close the channel 7 relay. Fixed 4-pole relay pairs are:

- 1 and 6 (not available for Model 2001-TCSCAN)
- 2 and 7
- 3 and 8
- 4 and 8
- 5 and 10.

OPEN-ALL-CHANNELS: Selecting OPEN-ALL-CHANNELS will immediately open any closed scanner card channels or channel pair for 4-wire functions.

Table 2-38
CHANNEL SELECTION menu structure

Menu item	Description
CLOSE-CHANNEL ENTER CHAN#01 (1-10)	Close channel menu: Use cursor, range, and ENTER keys.
OPEN-ALL-CHANNELS	Press ENTER to open closed channel(s).

Note: This menu is only available with a scanner card installed.

2.11.4 Using CONFIGURECHAN to configure channels

The CONFIGURE CHANNELS menu allows you to:

- Select measurement functions for internal scanner card channels, and define which channels to use when scanning.
- Select measurement functions and the number of channels in an external scanner used with the Model 2002.
- Define, save, and restore an alternate measurement function which can then be assigned to specific channels.

Table 2-39 summarizes the CONFIGURE CHANNELS menu structure, which is discussed in detail in the following paragraphs. Again, see paragraph 2.3.4 for more information on navigating menus.

The CONFIGURE CHANNELS menu is displayed by pressing CONFIG and then CHAN.

INTERNAL CHAN

The INTERNAL-CHANS selection allows you to set the measuring function for each of the internal scanner card channels. When this selection is made the currently selected function for each channel is displayed.

Changes are made by placing the cursor on the desired channel and using the RANGE ▲ and ▼ keys to select the desired measurement function:

- DCV: DC volts
- ACV: AC volts
- Ω2W: 2-wire ohms
- Ω4W: 4-wire ohms
- FRQ: Frequency
- TMP: Temperature
- ALT: alternate function (see below)
- JN1...JN5: Reference junction type
- : None

Ω4W function: The Ω4W function is valid only for channels 1-5 for the Model 2001-SCAN and channels 2-5 for the Model 2001-TCSCAN. If selected, “PRD” (paired) will be shown on the corresponding paired channel (6-10 for the Model 2001-SCAN and 7-10 for the Model 2001-TCS-CAN). Once Ω4W is selected for a valid channel, changing the assignment to a different function will de-assign the paired channel and change the function to “---” (none).

TMP function: The TMP function is valid for the same channels as the Ω4W function if the temperature sensor is a 4-wire RTD type. If a 2-wire RTD type is used, channels 6-10 could be assigned to the TMP function, but if the sensor type is later changed to a 4-wire RTD, any channel from 6-10 will then be set to “---” (none). Thermocouple TMP measurements, using the Model 2001-TCSCAN, can be assigned to channels 2-10.

Table 2-39
CONFIGURE CHANNELS menu structure

Menu item	Description
INTERNAL-CHANS SET INTERNAL CHANS 1=DCV 2=DCV 3=DCV 4=DCV 5=DCV	Defines internal functions: Use range and cursor keys to select channels and functions.
EXTERNAL INPUTS # EXTERNAL INPUTS=80 DEFAULT CHOOSE-FUNCTIONS SELECT CHAN=01 CHANNEL #01 FUNCTION	Sets number of external channels and functions: # of external channels (1-80). Selects default function for all external channels. Use to select channel functions. Select channel using range and cursor keys. Select function using cursor keys.
SAVE-ALT-FCN RESTORE-ALT-FUNCTION	Stores present function as alternate. Restores saved alternate function.

JN functions: Note that there are five reference temperature functions available (JN1-JN5). With the Model 2001-TCS-CAN, the reference junction must be assigned to channel 1. Junction types are defined using the CONFIGURE TEMPERATURE menu.

NOTE

The JN functions in the internal menu are intended for use with thermocouple scanner card (Model 2001-TCSCAN). The Model 2001-SCAN internal scanner card is not intended to be used with thermocouples.

No function (---): Selecting none (---) effectively removes that channel from the scan list. When scanning, the instrument will skip any channels that have no function defined.

EXTERNAL-INPUTS

This menu item allows you to select measurement functions for external scanner cards used with the Model 2002 Multi-meter. When the EXTERNAL-INPUTS menu item is selected, the instrument will prompt you to enter the number of channels being used.

Use the cursor and range keys to select the number of channels (1-80), then press ENTER. Once the number of inputs is selected, you will be prompted for channel functions.

Briefly, these menu items allow you to select the following:

DEFAULT: This selection assigns the presently selected measurement function to all external channels.

CHOOSE-FUNCTION: This menu item allows you define functions for each external channel. When selected, you will be prompted to enter the channel to be programmed. Use the cursor keys and the range keys to key in the channel and press ENTER. The instrument will then display the available functions.

Use the cursor keys to select the desired function, then press ENTER. Repeat the procedure for every external channel to be defined.

SAVE-ALT-FCN and RESTORE-ALT-FCN

An ALT (alternate) function is one that cannot be directly accessed with one of the eight function keys. For example, assume that you select the ACV peak function using CONFIG-ACV. You can then use SAVE-ALT to assign peak ACV to the ALT function. Whenever the ALT function is encountered in the scan list, the instrument will switch to the ACV

peak function for that channel even if the instrument is measuring a different type of ACV (RMS for example).

You can also use the ALT function to store an existing main function but with a different set of operating parameters. For example, you could set up a specific set of operating parameters for the straight DCV function and a second DCV setup as the ALT function. This arrangement allows you to specify changes in virtually any measurement parameter from channel to channel even if the measurement functions are the same.

NOTE

Some functions may not be compatible with certain scanner cards. For example, you should not use the DCI and ACI functions with the Model 2001-SCAN and 2001-TCSCAN internal scanner cards.

SAVE-ALT-FCN stores the presently selected function and all its configured settings as the ALT function.

RESTORE-ALT-FCN restores the function that was saved as the ALT function and all associated settings as if a normal function change were taking place.

2.11.5 Using CONFIG-SCAN to configure scanning

The SCAN OPERATION menu allows you to configure the following scanner aspects:

- Select the internal or external channel list for scanning.
- Enable ratio and delta operation.

Table 2-40 summarizes the SCAN OPERATION menu structure, which is discussed in more detail in the following paragraphs. See paragraph 2.3.4 for more information on menu navigation.

Pressing CONFIG-SCAN will display the SCAN OPERATION menu. These choices select the action the instrument will take when it is triggered.

INTERNAL

This selection enables scanning with the internal scanner card. When this selection is chosen, the Model 2002 will change to the function specified for the first channel and then close the channel and take a reading. When the next trigger is received, the instrument will open the present channel, change to the specified measuring function for the next chan-

nel, and then close the channel and take a reading. The process repeats until all channels in the list are scanned.

The instrument defaults to this selection if it detects a scanner card on power-up.

Table 2-40
SCAN OPERATION menu structure

Menu item	Description
INTERNAL	Enables internal scanning.
EXTERNAL	Enables external scanning.
RATIO MEASURE REFERENCE FUNCTION	Enables ratio mode (internal). Selects measure channel. Selects reference channel. Selects ratio function.
DELTA MEASURE REFERENCE FUNCTION	Enables delta mode (internal). Selects measure channel. Selects reference channel. Selects delta function.

EXTERNAL

This menu selection enables scanning with an external scanner card located in a switching mainframe. This selection operates in a manner similar to INTERNAL except that the internal scanner is not used. When this menu item is selected, the instrument will immediately change to the selected measuring function for the first channel. When the multimeter is triggered, it will take a measurement and then change to the measurement function for the next channel. This process repeats until all channels in the scan list are scanned.

The instrument defaults to this selection if it does not detect a scanner card on power-up.

RATIO and DELTA

Either of these two selections configures the Model 2002 to measure the two specified internal scanner channels and then compute the ratio or difference (delta) between them. When

RATIO or DELTA is selected, the instrument will close the scanner reference channel and then wait for a trigger. When the reading is triggered, the unit will make a measurement on the reference channel, switch to the measurement channel, and then take a second measurement. After measuring the measurement channel, the unit will compute and display the ratio or delta value, and switch back to the reference channel to wait for the next trigger. Note that the ratio mode uses 7-1/2 digits of display resolution, but the channel number will not be displayed.

The following options are available for RATIO and DELTA:

MEASURE: This option is used to select the measure channel. After selecting MEASURE, place the cursor on the desired channel and press ENTER.

REFERENCE: This option is used to select the measure channel. After selecting REFERENCE, place the cursor on the desired channel and press ENTER.

FUNCTION: This option is used to select the function. After selecting FUNCTION, place the cursor on the desired function (DCV, Ω2 or Ω4) and press ENTER.

Ratio and Delta computation: During configuration, one channel is defined as the reference channel, and a second channel is defined as the measurement channel. Ratio and delta are computed from signals measured on these channels as follows:

$$\text{Ratio} = \frac{\text{Measure}}{\text{Reference}}$$

$$\text{Delta} = \text{Measure} - \text{Reference}$$

2.11.6 Using SCAN to configure scan parameters

Once an internal or external scan list is enabled, you use the SCAN key to configure internal or external scanning. The menu structure of Figure 2-32 shows the procedure.

The procedure changes scan layer parameters in the trigger model. When scanning is disabled by the EXIT key, the trigger model is restored to its pre-scanning configuration.

```

Entry for external list → SCAN CONFIG EXT SCANNER
Reset scanner; press ENTR to >
< continue.

ENTER CONFIG EXT SCANNER
Set CHAN COUNT to infinite; >
< Press ENTER to continue.

ENTER SELECT TRIG SOURCE
TRIGLINK EXTERNAL TIMER>
< GPIB MANUAL IMMEDIATE

XXXXX CONFIG EXT SCANNER
Set CHAN SPACing to XXXXX. >
< Press ENTER to continue.

ENTER CONFIG EXT SCANNER
Set SCAN LIST for 80 channels >
< Press ENTER to continue.

ENTER CONFIG EXT SCANNER
STEP scanner to first cahnnel >
< Press ENTER to continue.

ENTER

Entry for internal list → SCAN SCAN COUNT = 00010 INFO: SCAN COUNT
Use <, >, ^, v, ENTER, EXIT, or INFO Number of scans

ENTER USE SCAN TIMER?
YES NO

YES INTERVL = 000000.000 INFO: TIMER
Use <, >, ^, v, ENTER, EXIT, or INFO For TIMER source, the interval >
< (in seconds) between triggers.

ENTER

NO DATA NO MEMORY?
YES NO

YES XXXXX RDGS TO BUFFER (Use CONFIG-STORE to
Press ENTER to continue. change number of readings)

ENTER

NO Press ENTER to begin
XXXX scans of XX channels or >
< press EXIT to abort.

ENTER +000.0000 mVDC CHXX
storing reading #XXX of XXX

SCAN COMPLETE
Storage complete; press RECALL

SCAN COMPLETE
RECALL-DATA SCAN-AGAIN EXIT

RECALL-DATA +000.0000 mVDC INFO: RECALL BY RDG#
Rdg# +00000 Use <, >, ^, v to change reading. >
< Use NEXTDISP to see statistics

EXIT SCAN COMPLETE
RECALL-DATA SCAN-AGAIN EXIT

SCAN-AGAIN Press ENTER to begin
XXXX scans of XX channels or >
< press EXIT to abort.

EXIT DISABLE EXT SCANNER
Set CHAN SPACING to MANUAL >
< Press ENTER to continue.

```

Figure 2-32
SCAN key menu structure

2.11.7 Starting and stopping scanning

Internal and external scanning

After an internal or external scan is configured, pressing the ENTER key from the SCAN menu starts scanning. Pressing the EXIT key disables scanning. An internal or external scan cannot be temporarily disabled.

Ratio/delta measurements

After ratio or delta measurements are selected from the SCAN OPERATION menu, the SCAN, TRIG, and EXIT keys control scanning. Press the SCAN key to start the operation, as shown in Figure 2-33.

SCAN	TRIGGERS HALTED Use SCAN key to resume: EXIT to quit
SCAN or TRIG	Ratio or delta measurements
SCAN	TRIGGERS HALTED Use SCAN key to resume: EXIT to quit
EXIT	SCANNING DISABLED Use SCAN key to resume
EXIT	SCANNING DISABLED Use SCAN key to resume

Figure 2-33

SCAN key menu structure for ratio and delta

Manual scanning

When using internal scanning, you can manually scan channels by pressing the ◀ or ▶ keys. To use this feature, first close a channel by using the CLOSE-CHANNEL option accessible with the CHAN key. Use ▶ to increment channels, or use ◀ to decrement channels. Hold down either key to continuously scan through channels manually.

Adjacent channel display

The multiple display mode can be used to display the two adjacent channels only when manually controlling channels. To use this feature, first manually close the desired channel, then press PREV to display alternate channels. You can then use the ◀ and ▶ keys to scroll through channel displays normally.

NOTE

The adjacent channel display mode cannot be used when scanning channels automatically using the internal or external scan list.

As an example, assume that you close channel 5 using the CHAN key. With the multiple display enabled, channels 4 and 6 will appear on the lower display line.

2.11.8 Scanner operation examples

The following paragraphs give step-by-step procedures for various scanner operating modes.

Closing and opening channels

Use the front panel CHAN key to close and open specific channels on the internal scanner card as follows:

1. From normal display, press the CHAN key. The instrument will display the following menu:
CHANNEL SELECTION
CLOSE-CHANNEL OPEN-ALL-CHANNELS
2. Select CLOSE-CHANNEL, then press ENTER. The Model 2002 will display the following prompt:
ENTER CHANNEL# 01 (1-10)
3. Use the cursor and range keys to select the channel you wish to close (1-10), then press ENTER. Any previously closed channel will open, and the selected channel will close.
4. To open the close channel, select OPEN-ALL-CHANNELS in the CHANNEL SELECTION menu, then press ENTER.

Manual scanning and using the multiple display

The ◀ and ▶ keys can be used to manually scan through channels on the internal scanner card. The multiple display mode can also be used to display adjacent scanner channels while scanning manually.

NOTE

Adjacent channel display cannot be used when the instrument is scanning automatically.

Follow the steps below to scan manually and display alternate channels.

1. Manually close a channel by using the CLOSE-CHANNEL selection accessible with the CHAN key.
2. Press the ▶ key to manually increment channels, or press the ◀ key to manually decrement channels. Hold down either key to manually scan through channels con-

tinuously. Auto-repeat of cursor keys is disabled when adjacent channel next display is shown.

3. With the unit in the normal display mode, press the PREV key to enable adjacent channel display. Note that the lower and upper adjacent channel readings will appear on the lower display section.
4. Manually scan through channels with the ◀ or ▶ key. Note that the adjacent display channel numbers track the channel on the main display.
5. Press the NEXT key to cancel the alternate channel display mode, then use the CHAN key to open channels when done scanning.

Scanning internal channels

Internal channels are scanned by configuring scan channels and programming the Model 2002 to perform a scan. The following steps demonstrate the basic procedures for performing basic scanning using the Model 2001-SCAN scanner card.

NOTE

Depending on selected trigger modes, it may be necessary to trigger the instrument to perform scanning. Refer to paragraph 2.7 for detailed information on triggering.

Step 1: Configure channels

Use CONFIG-CHAN to select the measurement functions for each of the scanner channels as follows:

1. Press CONFIG-CHAN. The instrument will display the following menu:

```
CONFIGURE CHANNELS
INTERNAL-CHANS  EXTERNAL-INPUTS ▶
◀ SAVE-ALT-FCN  RESTORE-ALT-FCN
```

2. Select INTERNAL-CHANS, then press ENTER. The multimeter will display the following menu:

```
SET INTERNAL CHANS
1=DCV 2=DCV 3=DCV 4=DCV 5=DCV ▶
◀ 6=DCV 7=DCV 8=DCV 9=DCV 10=DCV
```

3. Using the cursor keys, select the desired channel (press the right cursor key to display channels 6 through 10).
4. Using the range keys, select the desired measurement function: DCV, ACV, Ω2W, Ω4W, FRQ, TMP, ALT, JN1, JN2, JN3, JN4, JN5, --- (None).
5. Repeat steps 3 and 4 for each of the channels you wish to scan. Note: Select --- (none) to omit a channel from the scan list.

6. Examine all ten channels to verify omitted channels and paired (PRD) channels.
7. After selecting all measurement functions, press ENTER to return to normal display.

Step 2: Select internal scan list

Use the SCAN OPERATION menu to select the internal scan list as follows:

1. Press CONFIG-SCAN. The Model 2002 will display the following:

```
SCAN OPERATION
INTERNAL  EXTERNAL  RATIO  DELTA
```

2. Select INTERNAL, then press ENTER.

Step 3: Start scan

After configuring channels and scan list, simply press the SCAN key to begin scanning. The instrument will prompt you to configure the scan count and scan timer, and to enable data storage. Pressing the ENTER key will scan through selected channels and make a measurement on each channel using the previously selected measurement function for each channel. When the scan has completed, you can recall stored data and/or scan again. To disable scanning, press the EXIT key.

Using ratio and delta

The Model 2002 can display the difference (DELTA) or quotient (RATIO) between the signal on any two internal scanner channels. The following paragraphs discuss ratio and delta calculations and also give step-by-step procedures for using ratio and delta.

When the instrument is first placed in the ratio or delta mode, it will close the scanner reference channel and then wait for a trigger. When the reading is triggered, the unit will make a measurement on the reference channel, switch to the measurement channel, and then take a second measurement. After measuring the measurement channel, the unit will compute and display the ratio or delta value, and switch back to the reference channel to wait for the next trigger.

The steps below outline the basic procedure for making ratio measurements. The procedure for delta measurements is essentially the same, except that you would select DELTA in the appropriate menu.

Step 1: Connect inputs

Input signals must be connected to the two channels you intend to define as measurement and reference channels.

Step 2: Define measurement channel

1. From normal display, press CONFIG-SCAN. The instrument will display the following:

```
SCAN OPERATION
INTERNAL  EXTERNAL  RATIO  DELTA
```

2. Select RATIO, then press ENTER. The Model 2002 will display the following:

```
CONFIGURE RATIO
MEASURE  REFERENCE  FUNCTION
```

3. Select MEASURE, then press ENTER. The instrument will display the following:

```
RATIO MEASURE CHAN
CHI  2  3  4  5  6  7  8  9  10
```

4. Using the cursor keys, select the channel you wish to define as the measure channel, then press ENTER.

Step 3: Define reference channel

1. From the CONFIGURE RATIO menu, select REFERENCE, then press ENTER. The Model 2001 will display the following message:

```
RATIO REFERENCE CHAN
CHI  2  3  4  5  6  7  8  9  10
```

2. Using the cursor keys, select the channel to be defined as the reference channel, then press ENTER.

Step 4: Select measurement function

1. From the CONFIGURE RATIO menu, select FUNCTION, then press ENTER. The instrument will display the following:

```
SET RATIO FUNCTION
DCV  Ω2  Ω4
```

Note that only DC volts, and 2- and 4-wire ohms functions are available for ratio and delta modes.

2. Use the cursor keys to select the desired function, then press ENTER.
3. Press EXIT as necessary to return to normal display.

Step 5: Display ratio readings

Once the reference channel, measurement channel, and ratio function have been defined, press SCAN to halt triggers, then press TRIG or SCAN to display ratio readings. The instrument will automatically display ratio readings computed from signals applied to the reference and measurement channels. If you have selected a trigger mode that requires a separate trigger for each reading, you will, of course, have to

trigger the instrument to obtain each ratio reading (refer to paragraph 2.7 for details on triggering).

Step 6: Disabling and cancelling the ratio mode

You can disable the ratio mode by pressing EXIT while ratio readings are being displayed. To cancel the ratio mode, press CONFIG-SCAN, then select another option under the SCAN-OPERATION menu.

RTD temperature measurements

The following paragraphs outline the basic procedures for making RTD temperature measurements using the internal scanner. For more detailed information on temperature measurements in general, refer to paragraph 2.4.5.

Step 1: Connect RTD probes

Connect RTD probes to the scanner using the basic resistance connections outlined in the scanner card manual. For 4-wire probes, pair the connections as follows:

- Channels 1 and 6: probe #1
- Channels 2 and 7: probe #2
- Channels 3 and 8: probe #3
- Channels 4 and 9: probe #4
- Channels 5 and 10: probe #5

Step 2: Select sensor type and units

Use the CONFIGURE CHANNELS menu to select the RTD sensor type and the units you wish to display. See paragraph 2.4.5 for details.

Step 3: Configure channels

1. Press CONFIG-CHAN. The instrument will display the following:

```
CONFIGURE CHANNELS
INTERNAL-CHANS  EXTERNAL-INPUTS ►
◀ SAVE-ALT-FCN  RESTORE-ALT-FCN
```

2. Select INTERNAL-CHANS. The Model 2002 will display the following:

```
SET INTERNAL CHANNELS
1=DCV  2=DCV  3=DCV  4=DCV  5=DCV ►
◀ 6=DCV  7=DCV  8=DCV  9=DCV  10=DCV
```

3. Use the cursor and range keys to select channels and functions. Set the function type to TMP for all channels connected to RTD probes. Select --- (none) for channels without probes connected.
4. Press ENTER to return to normal display.

Step 4: Configure scan

1. From normal display, press CONFIG-SCAN. The instrument will display the following:

```
SCAN OPERATION
INTERNAL  EXTERNAL  RATIO  DELTA
```

2. Select INTERNAL, then press ENTER.

Step 5: Scan channels

To start scanning, press the SCAN key and program the scan count, scan timer, and data storage. Then press ENTER. When the scan has completed, you can recall stored data and/or scan again. Press EXIT while scanning to interrupt data storage and disable scanning.

Using the scanner with the data storage buffer

The Model 2002 internal data storage buffer can be used to store readings taken while using the scanner. The following paragraphs outline the basic steps necessary for data storage of scanner readings. Refer to paragraph 2.8 for additional information on using the data storage buffer.

Step 1: Configure channels

1. Press CONFIG-CHAN. The instrument will display the following:

```
CONFIGURE CHANNELS
INTERNAL-CHANS  EXTERNAL-INPUTS ►
◀ SAVE-ALT-FCN  RESTORE-ALT-FCN
```

2. Select INTERNAL-CHANS. The Model 2002 will display the following:

```
SET INTERNAL CHANNELS
1=DCV 2=DCV 3=DCV 4=DCV 5=DCV ►
◀ 6=DCV 7=DCV 8=DCV 9=DCV 10=DCV
```

3. Use the cursor and range keys to select channels and functions, then press ENTER when you have set all functions and channels.

Step 2: Configure scan

1. From normal display, press CONFIG-SCAN. The instrument will display the following:

```
SCAN OPERATION
INTERNAL  EXTERNAL  RATIO  DELTA
```

2. Select INTERNAL, then press ENTER.

Step 3: Trigger scan

Press SCAN to program the scan count, scan timer, data storage and select YES to the “Data to memory?” prompt. Then press ENTER. The unit will cycle through the channels, stopping to take and store a reading on each channel.

Step 4: Recall readings

From the SCAN COMPLETE menu, select the RECALL-DATA option to display readings stored in the buffer. Use the cursor and range keys to select the reading number to display. Note that the instrument will display the channel number for each buffer reading in addition to other pertinent buffer information. Press EXIT to return to the SCAN COMPLETE menu.

External scanning

Follow the general steps below to set Model 2002 modes for external scanning.

Step 1: Make scanner card connections

Be sure to connect your scanner signal lines and trigger cables as appropriate. See the scanner card documentation for details on signal connections. Paragraphs 2.7.6 and 2.7.7 provide information on external triggering and using the trigger link.

Step 2: Configure trigger parameters

Using CONFIG-TRIG, select the required trigger layer parameters based on the desired scanner and multimeter operation. See paragraph 2.7 for Model 2002 trigger parameter details.

Step 3: Configure external channels and functions

1. From normal display, press CONFIG-CHAN. The instrument will display the following:

```
CONFIGURE CHANNELS
INTERNAL-CHANS  EXTERNAL-INPUTS ►
◀ SAVE-ALT-FCN  RESTORE-ALT-FCN
```

2. Select EXTERNAL-INPUTS, then press ENTER. The Model 2002 will prompt you to enter the number of channels:

```
# EXTERNAL INPUTS=80
```

3. Use the range and cursor keys to set the number of external channels you will be using, then press ENTER. The instrument will prompt you to set functions:

```
SET CHAN FUNCTIONS
DEFAULT  CHOOSE-FUNCTIONS
```

4. If you wish to use the current default function for all channels, select DEFAULT, then press ENTER.
5. If you intend to program a separate function for each channel, choose CHOOSE-FUNCTIONS, then press ENTER. The instrument will prompt you for a channel number, as in the following typical display:
SELECT CHAN=01 (DCV)
6. Use the cursor and range keys to select a channel, then press ENTER. Select the desired function, then press ENTER. Repeat the procedure for all channels to be defined.
7. Press EXIT as necessary to return to normal display.

Step 4: Enable external scanning

1. From normal display, press CONFIG-SCAN. The instrument will display the following:
SCAN OPERATION
INTERNAL EXTERNAL RATIO DELTA
2. Select EXTERNAL, then press ENTER.

Step 5: Start scan

Press SCAN for instructions to set up the external scanner, program the scan count, scan timer, and data storage. Then press ENTER to start scanning. When the scan has completed you can recall stored data and/or scan again. Press EXIT to interrupt data storage and disable scanning.

2.12 Menu

The main menu accesses the various instrument operations for which there are no dedicated keys, such as setup storage, IEEE-488 setup, calibration, self-test, and limits. The main menu structure is summarized in Table 2-41.

The top level of the main menu is displayed by placing the instrument in the reading display state, and then pressing the MENU key.

Some general rules to navigate the menu levels are given in paragraph 2.3.4.

Table 2-41
Main menu structure

Menu item	Description
SAVESETUP SAVE RESTORE POWERON BENCH GPIB USER-SETUP-NUMBER RESET BENCH GPIB	Setup menu: Save setup at a memory location (up to 1, 5, or 10). Return 2002 to setup stored at a memory location (up to 1, 5, or 10). Power-on Menu: Power on to bench default setup conditions. Power on to GPIB default setup conditions. Power on to setup stored at a memory location (up to 1, 5, or 10). Reset Menu: Return 2002 to bench default setup. Return 2002 to GPIB default setup.
GPIB ADDRESSABLE TALK-ONLY FEED AFTER-CALC BEFORE-CALC NONE INTERFACE IEEE-488 CENTRONICS INTERVAL FORMFEED CONTROL SET-PAGE-SETUP ELEMENTS STATUS	GPIB/Printer Setup menu: Check/change IEEE-488 bus address (0-30). GPIB/Printer Talk-only mode menu: GPIB Output Feed menu: Specify reading after math operation. Specify reading before math operation. Specify no readings. Select printer interface. Specify IEEE-488 printer. Specify Centronics parallel printer. Specify printing interval (every reading to 1 out of 9999). Formfeeds menu: Enable/disable page breaks. Set number line between form feeds (1-255). Select GPIB data elements (reading, units, reading number, channel number, timestamp, status). Display IEEE-488 bus status byte.
CALIBRATION COMPREHENSIVE POINT CAL CALIBRATION-DATES	Calibration menu: Perform DC and AC calibration. Perform point calibrations. Check/change calibration date.
TEST BUILT-IN-TEST AUTOMATIC MANUAL DIAGNOSTICS FRONT-PANEL-TESTS KEYS DISPLAY-PATTERNS	Self-test menu: Test analog and digital boards. Run all tests automatically. Select tests to run. Factory diagnostic tests. Test display board. Verify operation of front panel keys. Verify operation of display.

Table 2-41
Main menu structure (cont.)

Menu item	Description
LIMITS LIMIT-SET-1 CONTROL LOLIM1 HILIM1 LIMIT-SET-2 CONTROL LOLIM2 HILIM2 STROBE-CONTROL PASS-PATTERN	Limits menu: Limit-Set-1 menu: Enable/disable limit set #1. Set value of low limit #1. Set value of high limit #1. Limit-Set-2 menu: Enable/disable limit set #2. Set value of low limit #2. Set value of high limit #2. Enable/disable limit strobe signal of digital output #4 when trigger occurs. Specify patterns on digital outputs to signify limits pass.
STATUS-MSG	Enable/disable status message mode.
GENERAL DIGITAL-I/O OUTPUT-STATE OUTPUT-SENSE INPUT SERIAL# A/D CONTROLS LINE-SYNC AUTO-ZERO TIMESTAMP TYPE RELATIVE-TIME REAL-TIME RESET-TIME RESET-RDG# DECIMAL CLOCK TIME DATE FORMAT 12-HOUR 24-HOUR	General menu: Digital I/O menu: Check/change states of digital output lines. Check/change sense of digital output lines. Read digital input line. Display serial number, memory option SCPI version, and firmware revisions. A/D menu: Enable/disable line synchronization of measurements. Also, displays the power line frequency. Disable or enable normal or synchronous autozero mode. Configure timestamp: Check or change type. Reference timestamp to relative time. Reference timestamp to real time. Reset relative timestamp to zero. Reset reading number to zero. Select period or comma for display of decimal point. Clock menu: Check or set time of day. Check or set date. Select clock format: 12-hour format (AM, PM). 24-hour format.

2.12.1 SAVESETUP

The SAVESETUP option of the main menu is used for the following operations:

- To save the present instrument configuration in non-volatile memory.
- To restore the instrument to a previously saved instrument configuration.
- To set the instrument's power-on configuration.
- To reset the instrument to a factory default configuration.

SAVE

Use this menu item to save the present instrument setup in a specific memory location. Depending on the memory option, you can store up to one (STD), five (MEM1), or ten (MEM2) setups in non-volatile memory. The installed memory option is displayed on power-up, and in the SERIAL# option of the General Menu (see paragraph 2.12.7).

After selecting SAVE, you will be prompted to save the present setup in a memory location. Note that the numbering of setup locations starts with setup #0. You can save the setup at memory location #0 or you can use the RANGE ▲ and ▼ keys to enter a different value. With the desired memory location displayed, press ENTER.

RESTORE

Use this menu item to return the instrument to a setup that was previously stored (see SAVE) in memory.

After selecting RESTORE you will be prompted to enter the memory location number of the setup that you wish to restore. Note that #0 is a valid memory location. Use the range keys (▲ and ▼) to key in the desired location and press ENTER. The instrument will immediately restore that setup configuration.

POWERON

Use this menu item to select the instrument setup that goes into effect on power-on.

The instrument can be set to power on to the factory bench defaults, the factory GPIB defaults, or to a user setup stored (see SAVE) at a specific memory location. These POWERON options are explained as follows:

BENCH: Use this option to return the instrument to the bench default conditions (see Table 2-42) the next time it is turned on.

GPIB: With this option, the unit returns to the GPIB default conditions (see Table 2-42) the next time it is turned on.

USER-SETUP-NUMBER: Using this option, the instrument powers on to a user setup saved at a specific memory location (see SAVE).

After selecting USER-SETUP-NUMBER, you will be prompted to enter the memory location number of the setup that you wish the instrument to power up to. Note that #0 is a valid memory location. Use the range keys (▲ and ▼) to key in the desired memory location and press ENTER.

RESET

Use this menu option to reset the instrument to the bench or GPIB default conditions (see Table 2-42).

The RESET options are explained as follows:

BENCH: With this option, the instrument returns to the bench default conditions (see Table 2-42). After selecting BENCH, the instrument returns to the normal display of readings after requesting an ENTER to confirm your selection.

GPIB: With this option, the unit returns to the GPIB default conditions (see Table 2-42). After selecting GPIB, the instrument returns to the normal display of readings after requesting an ENTER to confirm your selection. Note that the instrument goes to the Idle state.

Table 2-42
Factory default conditions

Function or operation	Bench default	GPIB default
AC current: AC-type Coupling Filter Auto Averaging Readings Advanced Readings Noise tolerance level Filter mode Range Relative Value Resolution Speed	RMS AC Off On Off 10 On 10 5% Moving Auto Off 0.0 Auto (5.5d) Normal (1 PLC)	RMS AC Off Off Off 10 On 10 5% Repeat Auto Off 0.0 Auto (5.5d) Normal (1 PLC)
AC voltage: AC-type Peak spikes window Coupling Filter Auto Averaging Readings Advanced Readings Noise tolerance level Filter mode Range Relative Value Resolution Speed Units dB reference dBm reference	RMS 0.1sec AC Off On Off 10 On 10 5% Moving Auto Off 0.0 Auto (5.5d) Normal (1 PLC) Volts 1V 75Ω	RMS 0.1sec AC Off Off Off 10 On 10 5% Repeat Auto Off 0.0 Auto (5.5d) Normal (1 PLC) Volts 1V 75Ω
Autozero	On (Synchronous)	On (Synchronous)
Buffer: Burst mode Control Count Data group Feed	No effect No effect No effect No effect No effect	No effect No effect No effect No effect No effect

Table 2-42
Factory default conditions (cont.)

Function or operation	Bench default	GPIB default
DC current:		
Filter	On	Off
Auto	On	Off
Averaging	Off	Off
Readings	10	10
Advanced	On	On
Readings	10	10
Noise tolerance level	1%	1%
Filter mode	Moving	Repeat
Measurement mode	Normal	Normal
Range	Auto	Auto
Relative	Off	Off
Value	0.0	0.0
Resolution	Auto (6.5d)	Auto (6.5d)
Speed	Normal (1 PLC)	Normal (1 PLC)
DC voltage:		
Filter	On	Off
Auto	On	Off
Averaging	Off	Off
Readings	10	10
Advanced	On	On
Readings	10	10
Noise tolerance level	1%	1%
Filter mode	Moving	Repeat
Range	Auto	Auto
Relative	Off	Off
Value	0.0	0.0
Resolution	Auto (7.5d)	Auto (7.5d)
Speed	Normal (1 PLC)	Normal (1 PLC)
Digital I/O:		
Output states	No effect	No effect
Output sense	No effect	No effect
Frequency:		
Coupling	AC	AC
Maximum signal level:		
Function	Voltage	Voltage
Voltage level	10V	10V
Current level	1mA	1mA
Relative	Off	Off
Value	0.0	0.0
Resolution	Auto (5d)	Auto (5d)
Terminals	Voltage	Voltage
Trigger level	0.0	0.0
Function	DCV	DCV

Table 2-42
Factory default conditions (cont.)

Function or operation	Bench default	GPIB default
Limits:		
Limit set #1	Off	Off
Low limit #1	-1.0	-1.0
Low limit #1 action	0	0
High limit #1	1.0	1.0
High limit #1 action	0	0
Limit set #2	Off	Off
Low limit #2	-1.0	-1.0
Low limit #2 action	0	0
High limit #2	1.0	1.0
High limit #2 action	0	0
Strobe control	Off	Off
Pass pattern	0	0
Line synchronization	Off	Off
Math	Off	Off
Function	Percent	Percent
Reference for percent	1.0	1.0
“a0” factor for polynomial	0	0
“a1” factor for polynomial	1	1
“a2” factor for polynomial	0	0
Resistance (2-wire):		
Filter	On	Off
Auto	On	Off
Averaging	Off	Off
Readings	10	10
Advanced	On	On
Readings	10	10
Noise tolerance level	1%	1%
Filter mode	Moving	Repeat
Offset compensation	Off	Off
Range	Auto	Auto
Maximum autorange	1GΩ	1GΩ
Relative	Off	Off
Value	0.0	0.0
Resolution	Auto (7.5d)	Auto (7.5d)
Speed	Normal (1 PLC)	Normal (1 PLC)

Table 2-42
Factory default conditions (cont.)

Function or operation	Bench default	 GPIB default
Resistance (4-wire):		
Filter	On	Off
Auto	On	Off
Averaging	Off	Off
Readings	10	10
Advanced	On	On
Readings	10	10
Noise tolerance level	1%	1%
Filter mode	Moving	Repeat
Offset compensation	Off	Off
Range	Auto	Auto
Maximum autorange	2M Ω	2M Ω
Relative	Off	Off
Value	0.0	0.0
Resolution	Auto (7.5d)	Auto (7.5d)
Speed	Normal (1 PLC)	Normal (1 PLC)
Scanning:		
Channels	No effect	No effect
Scan list:		
Internal list	No channels	No channels
External list	No channels	No channels
Function	DC voltage	DC voltage
Scan operation	None	None
Ratio:		
Reference channel	5	5
Measure channel	10	10
Function	DC voltage	DC voltage
Delta:		
Reference channel	5	5
Measure channel	10	10
Function	DC voltage	DC voltage

Table 2-42
Factory default conditions (cont.)

Function or operation	Bench default	GPIB default
Temperature:		
Filter	On	Off
Auto	On	Off
Averaging	On	On
Readings	10	10
Filter mode	Moving	Repeat
Relative	Off	Off
Value	0.0	0.0
Resolution	Auto (0.01°C)	Auto (0.01°C)
RTDs:		
Type	PT100	PT100
Resistance at 0°C	100Ω	100Ω
Alpha	0.00385	0.00385
Beta	0.10863	0.10863
Delta	1.49990	1.49990
Sensor	4-wire RTD	4-wire RTD
Speed	Normal (1 PLC)	Normal (1 PLC)
Thermocouples:		
Type	J	J
Reference junction	Simulated	Simulated
Default temperature	23°C	23°C
Real junction temp. coefficient	10mV/°C	10mV/°C
Offset	0mV @ 0°C	0mV @ 0°C
Units	°C	°C
Triggers:	Armed	Idled
arm layer:		
Source	Immediate	Immediate
Triglink input	Line 2	Line 2
Triglink output	Line 1	Line 1
Count	1	1
Control	Acceptor	Acceptor
scan layer:		
Source	Immediate	Immediate
Triglink input	Line 2	Line 2
Triglink output	Line 1	Line 1
Delay	0	0
Count	Infinite	1
Control	Acceptor	Acceptor
measure layer:		
Source	Immediate	Immediate
Triglink mode	Asynchronous	Asynchronous
Triglink input	Line 2	Line 2
Triglink output	Line 1	Line 1
Timer	0.1sec	0.1sec
Delay	0	0
Count	Infinite	1
Control	Acceptor	Acceptor

2.12.2 GPIB

The GPIB menu is used for the following operations:

- To view or change the IEEE-488 address.
- To select the talk-only mode and its parameters.
- To select the data elements to send.
- To view the status byte of the instrument.

Changing between “Addressable” and “Talk-only” causes triggers to be halted.

ADDRESSABLE

With the instrument set for “Addressable”, it can listen and talk to a bus controller. This menu item lets you check and/or change the IEEE-488 address of the instrument. At the factory the address is set to 16, but it can be changed to any value from 0 to 30.

After selecting ADDRESSABLE, the present IEEE-488 address will be displayed. If you wish to change the address, use the RANGE ▲ and ▼ keys to display the desired number and press ENTER.

TALK-ONLY

In the talk-only mode, the Model 2002 ignores commands from the bus and merely outputs data, as requested by the printer. When the instrument is in the talk-only mode, the TALK annunciator turns on.

The options for TALK-ONLY are explained as follows:

FEED: This item has options that select the type of readings printed: readings after a math operation is performed (AFTER-MATH), readings before a math operation (BEFORE-MATH), or no readings (NONE).

INTERFACE: With the IEEE-488 option of this item, data elements are sent to an IEEE-488 bus printer set for listen always. With the CENTRONICS option, data elements are sent to a printer with a Centronics (parallel) interface. The printer must be connected with a Model 8530 IEEE-488 to Centronics Printer Adapter Cable.

INTERVAL: The INTERVAL option controls how often readings are printed (expressed as 1 out of nnnn readings).

FORMFEED: Use the FORMFEED option of the menu to enable or disable the sending of a formfeed character to the printer after printing a user-selectable number of lines per page (1-255 lines).

ELEMENTS

This menu item lets you select the data elements sent:

- Reading — The numeric value of the reading.
- Units — The units of the reading.
- Reading# — The buffer location of the reading. The reading number can be reset to zero from the GENERAL MENU (see paragraph 2.12.7).
- Chan# — The channel number on which the reading was taken.
- Timestamp — The real-time or relative timestamp for each reading. Timestamp type is selected from the GENERAL MENU (see paragraph 2.12.7).
- Status — The reading status information (normal reading, measurement overflow, relative reading).

STATUS

Use this menu item to view the IEEE-488 status byte. Refer to Section 3 (IEEE- 488 Reference) for information on the status byte.

The bits in the status byte are refreshed by exiting and re-entering its menu.

2.12.3 CALIBRATION

The CALIBRATION menu is used for the following operations:

- To perform comprehensive calibration.
- To perform point calibration.
- To view or change the calibration date.

Some of the menu items are locked to prevent unintended changing of calibration constants.

COMPREHENSIVE

The procedure for comprehensive calibration is locked; to enable it requires the CAL switch to be pressed. The procedure uses accurate calibration equipment to supply precise DC voltages, DC currents and resistance values. Refer to the Model 2002 Calibration Manual for instructions.

POINT-CALS

This menu item is used to perform calibration for selected functions. AC calibration requires no external equipment and can be performed by the operator at any time to ensure the accuracy of ACV and ACI measurements.

DCV, ohms, and DCI calibration requires the use of accurate calibration equipment and is only intended to be performed by qualified service personnel. Refer to the Model 2002 Calibration Manual to calibrate these functions.

AC-CAL: Use this menu item to perform the AC self-calibration procedure.

NOTE

The AC calibration constants generated by this procedure are not permanently stored. They are in effect only until the power is turned off. To permanently store AC calibration constants, refer to the Model 2002 Calibration Manual.

To perform an AC-only calibration, follow these steps:

1. The Model 2002 must be allowed to warm up for at least one hour before calibration.
2. Disconnect all test leads or cables from the front and rear INPUT and SENSE jacks.
3. Select POINT-CALS from the PERFORM CALIBRATION menu.
4. Press ENTER to begin AC calibration, which takes about six minutes to complete.

NOTE

All keypresses are locked out when a calibration step is in progress.

5. Once the process has successfully completed, the "AC CAL COMPLETE" message is displayed, and you can press ENTER or EXIT to return to a normal display.

DCV, OHMS and DCI: These menu items are used to calibrate DCV, ohms and DCI. The calibration procedures are locked out to prevent accidental changing of calibration constants. These calibration procedures should only be performed by qualified service personnel. Refer to the Model 2002 Calibration Manual for details on performing point calibration for these functions.

CALIBRATION-DATES

Use this menu item to view or change the calibration dates.

Use the VIEW option of the menu to display the last calibration date and the next calibration date. The DISPLAY-AT-POWERUP option controls whether the next calibration date is displayed during the power-up sequence.

The CHANGE option is locked; to enable it requires the CAL switch to be pressed. The option allows you to change the calibration date and next calibration date. Refer to the Model 2002 Calibration Manual for instructions.

2.12.4 TEST

The SELF-TEST MENU is used as a diagnostic tool to isolate problems with the Model 2002. Information on using these test procedures is included in the optional Model 2002 Repair Manual.

2.12.5 LIMITS

The LIMITS menu is used for the following operations:

- To set and control the limit values that determine the PASS/FAIL and HI/LO status of subsequent measurements.
- To set the digital output patterns that signify passing or failing limit checks.
- To enable/disable a binning strobe signal on digital output #4 for triggering a user-supplied device handler.

NOTE

Since the logic sense of the digital output lines is programmable (high-true or low-true), this discussion of limits uses the logical terms TRUE/FALSE and ON/OFF, rather than HIGH and LOW.

There are two sets of limits, each with high and low limit values. You can program and enable one or both limit sets. With both sets enabled, the values can overlap or one set can be included in the other. The only restriction is that, within the same set, the high limit must be greater than the low limit for a valid test.

The limit test is performed after polynomial and percent math operations. Unit prefixes are applied before the limit test, for example:

- Low limit = -1.0, High limit = 1.0.
A 150mV reading equals 0.15V (PASS).
- Low limit = -1.0, High limit = 1.0.
A 0.6k Ω reading equals 600 Ω (FAIL).

Limit set #1 is available as a multiple display, which shows a bar graph and a pass/fail indication for the measurements. (Note: The PASS/FAIL indication is not available for ACV,

ACI, and in-circuit current because other information is displayed in its place.) While the limits bar graph is displayed, the programmed values for limit set #1 can be viewed by pressing INFO.

The digital output lines can be programmed to reflect the results of limit tests. The first test that fails sets a programmable digital output pattern, where the test execution order is LOW1, HIGH1, LOW2, HIGH2. If all tests pass, another programmable pattern is set. (Also see DIGITAL I/O in paragraph 2.12.7.)

LIMIT-SET-1 and LIMIT-SET-2

These menu items are similar in that you can enable or disable either or both limit sets, and program the high and low limit values for either or both limit sets.

The options for these menu items are explained as follows:

CONTROL: This item enables or disables control of the digital output lines by the results of either or both limit set tests. For example, to let limit set #1 control the digital output lines, highlight the CONTROL item in the previous menu and press ENTER. Then highlight the ENABLE item in the next menu and press ENTER. The instrument returns to the LIMIT SET #1 MENU.

LOLIM1, HILIM1, LOLIM2, HILIM2: These items allow you to set values for the low and high limits, and the action performed on the digital output lines for each limit test failure.

After selecting a limit, the value for that limit will be displayed. To change the limit, use the cursor keys and the range keys to display the desired value. Note that you must enter values in scientific notation.

Press ENTER to select your value and display the next menu which selects the digital output action to be taken if the selected limit is the first limit to be exceeded. The digital outputs can be toggled between ON and OFF with the range keys.

Each measurement function except frequency has a multiple display for the limits bar graph. It shows a pass/fail indication and a graphical representation of the reading compared to limit set #1. (Note: PASS/FAIL indication is not available on ACV, ACI, and in-circuit current.) If low limit #1 is less than high limit #1, you will see a display similar to that shown in Figure 2-34.

Note that the Model 2002 does not check the validity of the high and low limit values when you enter them. If low limit #1 is greater than or equal to high limit #1, the following

message is shown on the bottom line of the limits bar graph next display:

No bar graph: LLIM1 >= HLIM1

The programmed values for limit set #1 are shown by pressing the INFO key from the limits bar graph next display.

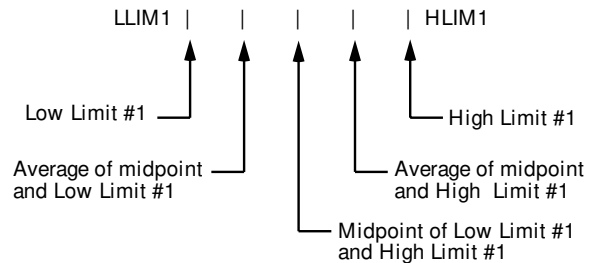

A. Defined points of display

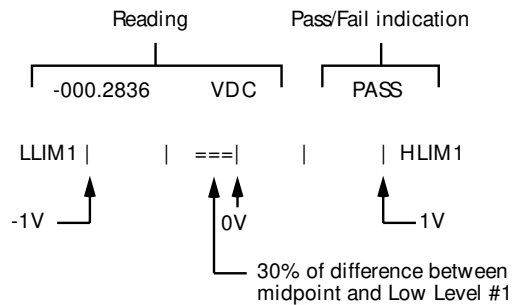

- NOTES: 1. Press INFO to view the programmed Low Limit #1 and High Limit #1 values.
- 2. Multiple display of limit values do not use unit prefixes (i.e., volts not millivolts).

B. Example Display with Limits = ±1V

Figure 2-34
Limits bar graph example

STROBE-CONTROL

This menu item enables or disables the use of digital output #4 as a binning strobe signal.

If enabled, the strobe signal is set TRUE for greater than 10 microseconds after all limit tests have been performed on a new reading. The FALSE to TRUE transition can be used to trigger an external device handler to check digital outputs #1-3 for sorting parts into bins.

When binning is enabled from the front panel or with the bus command :CALCulate3:BSTRObe:STATe ON, the binning strobe signal is set to FALSE. When binning is disabled, the strobe signal is left unchanged.

DISABLED: Use this selection to disable strobe control.

ENABLED: Use this selection to enable strobe control.

PASS-PATTERN

This item allows you to program the on/off states of the digital output lines for when all limit tests pass. Note that when the binning strobe is enabled, digital output line #4 cannot be used.

Selecting PAS-PATTERN displays the digital output pattern that occurs when all limit tests pass. To change the pattern, use the cursor keys and the range keys. The range keys toggle the parameter values between OFF and ON.

Limits example

This example sorts a quantity of 100Ω resistors into five bins, according to the following tolerances:

- Values less than 90Ω (outside -10% tolerance).
- Values greater than 110Ω (outside +10% tolerance).
- Values between 90Ω and 99Ω (meets -10% tolerance).
- Values between 101Ω and 110Ω (meets +10% tolerance).
- Values between 99Ω and 101Ω (meets ±1% tolerance).

The desired test is shown in Figure 2-35. Use the following procedure to program the limits:

1. From the LIMITS menu, set the limit values and actions according to the following table:

Limit	Value	Action
LOLIM1	90Ω	DIGOUT1=ON, others OFF
HILIM1	110Ω	DIGOUT2=ON, others OFF
LOLIM2	99Ω	DIGOUT1=ON, DIGOUT2=ON, others OFF
HILIM2	101Ω	DIGOUT3=ON, others OFF

2. Enable the binning strobe signal from the STROBE-CONTROL item of the LIMITS menu.
3. Set a pass pattern of all lines off from the PASS PATTERN item of the LIMITS menu.
4. Enable the control of the digital output lines by limit set #1 and limit set #2 from the LIMIT SET #1 and LIMIT SET #2 menus. This sets the digital output lines to the “pass pattern” (all OFF in this example). Since binning is enabled, digital output #4 is also OFF.

Note that the actual state (high or low) of the digital output lines depends on the polarity (ACTIVE-HIGH or ACTIVE-LOW). This is programmed from the DIGITAL I/O selection of the GENERAL menu.

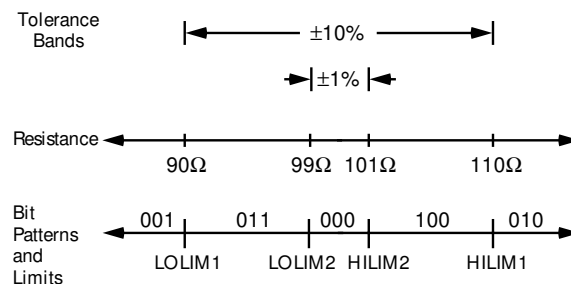

Figure 2-35
Using limit test to sort 100Ω resistors

2.12.6 STATUS-MSG

This selection is used to enable or disable the status messages mode. When enabled, status messages are displayed to identify specific operations that are performed.

ON: Enable the status message mode.

OFF: Disable the status message mode.

The instrument may become so busy displaying status messages, that keypresses are no longer acknowledged. You may have to clear status message display by pressing the EXIT key or sending a bus command (:DISPlay:SMESsage OFF) to get out of this mode.

2.12.7 GENERAL

The GENERAL menu is used for the following operations:

- To control the state and sense of the digital outputs; to view the state of the digital input.
- To view the serial number, memory option, SCPI version, and firmware revision levels of the Model 2002.
- To control the frequency of autozero readings and to set line synchronization of readings.
- To configure timestamp.
- To choose the character displayed for a decimal.
- To set the real-time clock.

DIGITAL I/O

Overview

The Model 2002's Digital I/O port is a 9-pin "D" sub-miniature connector located on the rear panel. The port's location and pin designations are shown in Figure 2-36.

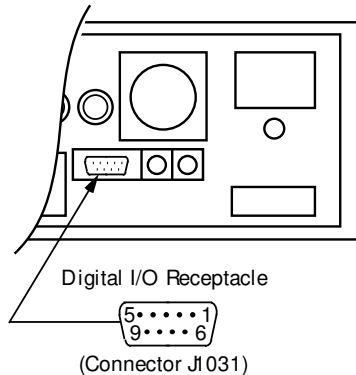

Pin Designations

1 =	Digital Input
2 =	N/C
3 =	N/C
4 =	V _{ext} fly-back connection (+5V to 30V)
5 =	Digital Ground
6 =	Digital Output #1
7 =	Digital Output #2
8 =	Digital Output #4
9 =	Digital Output #3

Figure 2-36

Digital I/O port

The Model 2002's Digital I/O port can be used to control external circuitry. The port provides four output lines and one input line. Each open-collector output can be set high (+5V) or low (0V) and will sink up to 100mA. A TTL high on the Model 2002's digital input is read as "ON". The four output lines can also operate external supplies from +5V to +30V.

Use the DIGITAL I/O Menu to select the following options:

- **OUTPUT-STATE**
ON or OFF selectable for each output line (1 through 4). Use to check or change the output state.
- **OUTPUT-SENSE**
ACTIVE-HIGH or ACTIVE-LOW selectable for each output line (TTL1 through TTL4). Use to check or change the output sense.

- **INPUT**

ON or OFF. Use to check or change the status of the digital input line. Sense is fixed at active-high (ON=5V).

Controlling digital circuitry

Each of the four digital, open-collector outputs (connector J1031, pins 6 through 9) includes a built-in pull up resistor to +5V. The output transistor is capable of sinking up to 100mA from voltages up to +30V. The outputs can be controlled independently or tied to one of four limit values (two high, two low). Paragraph 2.12.5 contains information about controlling digital outputs from the limits menu.

Early versions of the Model 2002 have an additional 10kΩ resistor connected between the collector and the internal built-in test circuitry. Under certain combinations of output states, this resistor limits the output high to 2.5V.

For example:

Output #1 set high (+5V)

Outputs #2, #3, and #4 set low (0V)

Output #1 is restricted to +2.5V

If using the digital output to sink current from external devices, a Model 2002 containing the additional 10kΩ resistor will function correctly. The transistor switch is open restricting current flow through the external device in the high state (+5V). However, if the output is directly used as an input to a typical logic input, the 2.5V high state may not be reliably detected as a high. To correct this condition (if a 2.5V high is unacceptable), add external 1kΩ pull up resistors to the logic circuit inputs, remove the built-in test resistors (R734, R737, R739, and R741), or use an external voltage supply.

External voltage supply

Each output can be operated from external voltage supplies (voltage range from +5V to +30V applied through the device being driven). Refer to Figure 2-37 for a simplified schematic of the digital I/O port. The high current sink capacity of the output driver allows direct control of relays, solenoids, and lamps, with no additional circuitry needed. Each output channel contains a fly-back diode for protection when switching inductive loads (such as a low power solenoid or relay coils). To use these fly-back diodes, connect the external supply voltage to pin 4 of J1031 (the digital I/O port). Make sure the external supply voltage is between +5V and +30V and the current required by the device does not exceed 100mA.

CAUTION

Do not apply more than 100mA maximum current or exceed +30V maximum voltage on pin 4 of J1031 (the digital I/O port). Applying current or voltage exceeding these limits may damage the instrument.

to turn on externally powered devices, set the corresponding digital output line parameters as follows (through the GENERAL/DIGITAL I/O menus):

OUTPUT-STATE=ON
OUTPUT-SENSE=ACTIVE-LOW

In the low state (0V), the output transistor sinks current through the external device. In the high state, the output transistor is off (transistor switch is open). This interrupts current flow through the external device. Most applications use active-low (ON=0V) OUTPUT-SENSE. Use the OUTPUT-SENSE menu to check or change the sense of the digital output line.

An externally powered relay connected to the digital output port is shown in Figure 2-38. Other externally powered devices can be similarly connected by replacing the relay with the device. When using the Model 2002's collector outputs

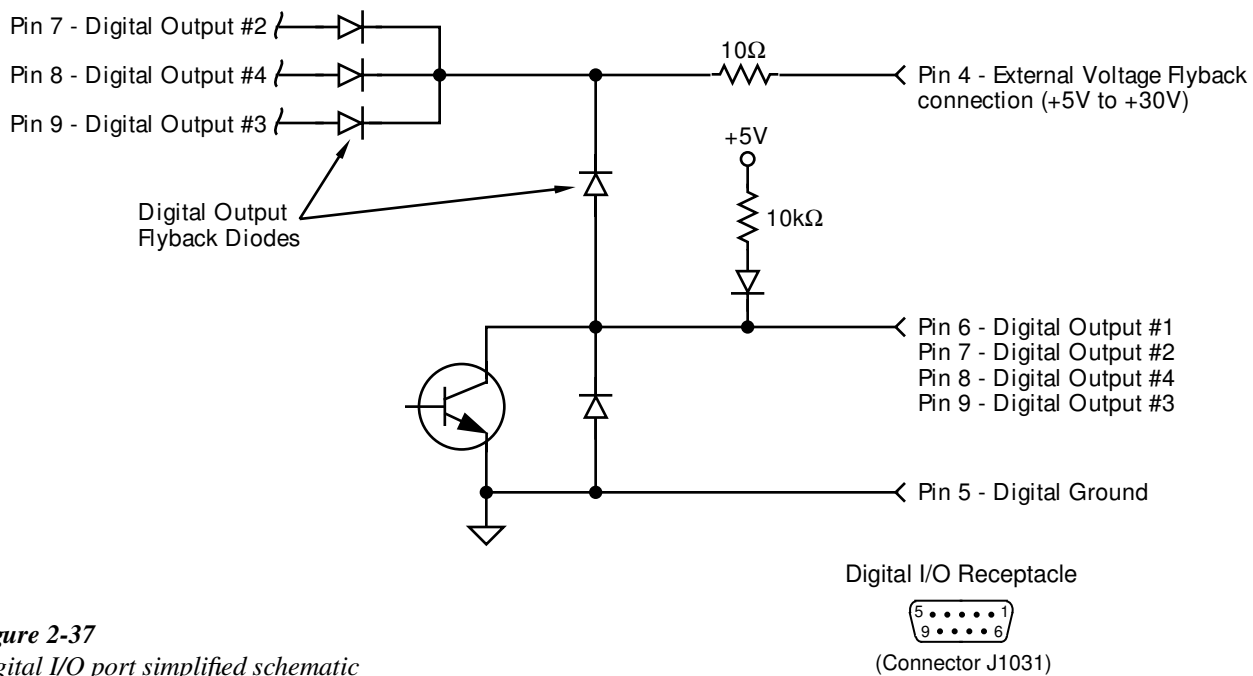

Figure 2-37
Digital I/O port simplified schematic

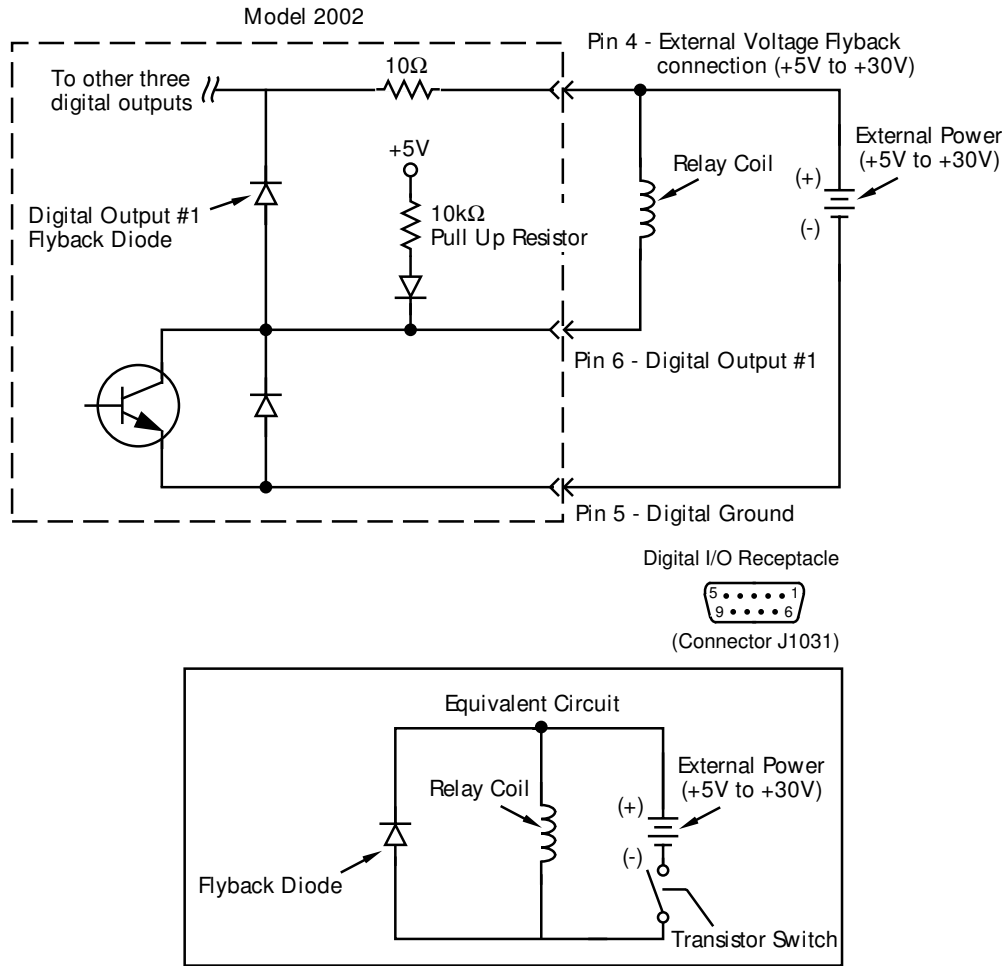

Figure 2-38
Sample externally powered relay sample

Outputs used as logic inputs

To use the digital outputs as logic inputs to active TTL, Low-power TTL, or CMOS inputs:

1. Connect the Model 2002 digital outputs to the logic inputs.
2. Connect the digital grounds.
3. Using the STATE menu, check the output state setting of the Model 2002 output lines. The STATE value for each output used should be ON.
4. Using the LOGIC-SENSE menu, check the logic-sense setting of the Model 2002 output lines (TTL1 through TTL4). Make sure the correct LOGIC-SENSE value is selected for each output line. The LOGIC-SENSE value varies according to the type of TTL, Low-power TTL, or CMOS inputs used (ACTIVE-HIGH or ACTIVE-LOW).

NOTE

If any LIMITS control is enabled (LOLIM1 or 2, HILIM1 or 2—High, Low, or Pass), the OUTPUT-STATE menu does not check or change the output status. Refer to paragraph 2.12.5 for information on limits.

Input

The single digital input is located on the digital I/O port (connector J1031, pin 1). The input sense is fixed at active-high (ON=5V). Use the INPUT menu to change the status of the input to ON or OFF.

Digital I/O menu

Access the DIGITAL I/O menu as follows:

1. Display the GENERAL MENU.
2. Use the ◀ and ▶ keys to highlight DIGITAL I/O, and press Enter. The following will be displayed:

```
DIGITAL I/O MENU
OUTPUT-STATE  OUTPUT-SENSE  INPUT
```

The DIGITAL I/O menu is used to configure the following operations:

- Check or change the OUTPUT-STATE (ON or OFF) of the four digital output lines.
- Check or change the OUTPUT-SENSE of the digital output lines. The logic sense can be active-high (ON = +5V) or active-low (ON = 0V).
- Check the status (ON or OFF) of the single digital input line.

OUTPUT-STATE: Use this menu item to check or change the state (on or off) of the four digital output lines. The actual level of an “on” line is determined by the sense, which is controlled by the next menu item (OUTPUT-SENSE).

The state (on or off) of a digital output line is changed by placing the cursor on the desired line and pressing the RANGE ▲ or ▼ key. These keys simply toggle the state. With the lines configured as desired, press ENTER.

OUTPUT-SENSE: Use this menu item to check or change the sense of the digital output lines. The sense of each line can be active-high (ON = +5V) or active-low (ON = 0V).

When OUTPUT-SENSE is selected, you will be prompted to select the desired output line:

- TTL1, TTL2, TTL3 OR TTL4 — Selects the digital output line and displays the following options:
 - ACTIVE-HIGH — Use this option to set the sense of the selected output line to active-high.
 - ACTIVE-LOW — Use this option to set the sense of the selected output line to active-low.

To check or change output sense, place the cursor on the appropriate line and press ENTER. Cursor position indicates the present logic sense for the selected line (ACTIVE-HIGH or ACTIVE-LOW). To change the sense, place the cursor on the alternate selection and press ENTER.

INPUT: Use this menu item to read (ON or OFF) the digital input line. Its sense is fixed at active-high (ON = 5V). The status is updated when INPUT is selected.

SERIAL

This item displays the serial number, memory option, SCPI version, and firmware revision levels of the instrument. The following information is displayed:

```
Serial #XXXXXXX MEM1
SCPI version 1991.0 ▶
◀ software rev AXX/AYY
```

where: #XXXXXXX is the serial number of the instrument.
MEM1 is the memory option present (also could be STD or MEM2)
AXX is the firmware level for the main microcontroller.
AYY is the firmware level for the display microcontroller.

A/D CONTROLS

With this GENERAL MENU item, you can control auto zero and line synchronization.

LINE-SYNC: Synchronizing A/D conversion with the power line frequency increases common mode and normal mode noise rejection. When line cycle synchronization is enabled, the measurement is initiated at the first positive-going zero-crossing of the power line cycle after the trigger (See Figure 2-39).

When LINE-SYNC is selected, the power line frequency is displayed and the options for line synchronization are displayed:

- ENABLED — Enables line synchronization.
- DISABLED — Disables line synchronization.

Changing the state of line synchronization halts triggers and puts the instrument into idle. Press TRIG to return to re-arm triggers.

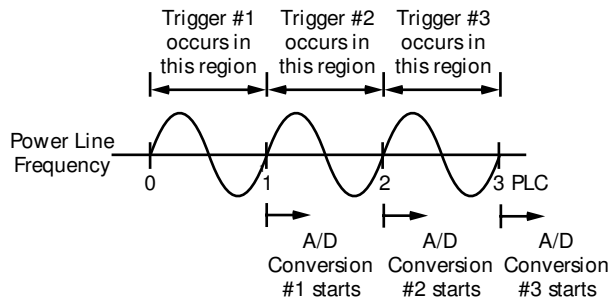

Note: A/D conversions assume an integration time of ≤ 1 PLC (Power Line Cycle)

Figure 2-39
Line cycle synchronization

AUTOZERO: In order to maintain stability and accuracy over time and temperature, the Model 2002 intermittently measures internal voltages corresponding to offsets and gains of amplifiers. This process is known as autozeroing. There are three types of autozero: synchronous, normal, and off. The characteristics of each are described below.

- **Synchronous** (the default mode) is the most accurate, but slowest mode. In this mode, each trigger causes three A/D conversions: one for input signal, one for an internal zero, and one for an internal gain. This mode also yields a constant reading rate.
- **Normal** is slightly less stable than synchronous, but significantly faster. In this mode, internal measurements are only taken often enough to maintain specified accuracy. Because internal readings are not consistently taken, the reading rate is higher, but not constant.
- **Off** disables the autozeroing mechanism. This mode yields the fastest reading rate at the expense of decreased reading stability.

With this selection, the type of autozero is chosen. Changing autozero halts triggers and puts the instrument into the idle state. Use the TRIG key to re-arm triggers. In addition, entering the burst data acquisition mode disables autozero.

NOTE

With autozero disabled, calibration accuracy will drift with time and temperature. It is recommended that an autozero refresh be performed every 24 hours to ensure measurement integrity. This can be performed by enabling and then disabling autozero, by changing speed or function, or by issuing an autozero bus command.

The burst data acquisition mode disables autozero. This type of measurement requires an autozero refresh once every 24 hours by performing one of the following:

- Change the display resolution.
- Change the measurement function.

The options for AUTOZERO are as follows:

- **DISABLE** — Disables autozero.
- **NORMAL** — Enables normal autozero.
- **SYNCHRONOUS** — Enables synchronous autozero.

Changing autozero halts triggers and puts the instrument into the idle state. Use the TRIG key to re-arm triggers.

TIMESTAMP

A timestamp is available for readings sent over the bus and for readings stored in the buffer. This GENERAL menu selection is used to configure the timestamp for readings sent over the IEEE-488 bus. From the front panel, readings are sent over the bus via the GPIB selection of the MAIN MENU (see paragraph 2.12.2). See paragraph 2.8.2 to configure the timestamp for buffer readings.

Specifically, this selection is used to perform the following operations:

- Select the type of timestamp; relative or real-time.
- Reset the relative timestamp to zero.
- Reset the reading number to zero.

Timestamp and the reading number are only included with each reading if they are selected as GPIB data elements (see paragraph 2.12.2). Figure 3-18 shows how the timestamp and reading number is included with each reading.

The menu items for TIMESTAMP are explained as follows:

TYPE: This item is used to check or change timestamp type. Note that changing the timestamp type clears the buffer. The two timestamp types are described as follows:

- **RELATIVE TIME** — With this selection, timestamps are oriented to a timer and references each reading to a point in time. The timer starts at 0.000000 seconds when the instrument is turned on or when the relative timestamp is reset (see RESET-TIME). After 99,999,999999 seconds, the timer resets to zero seconds and starts over.
- **REAL-TIME** — With this selection, timestamps are oriented to the real-time clock and provide the current time (24-hour format) and date for each reading.

Timestamp type for bus readings is coupled to timestamp type for buffer readings. Thus, if you change timestamp type from this menu structure, it also changes in the CONFIG DATA STORE menu structure (see paragraph 2.8).

RESET-TIME: This item is used to reset the relative timestamp to 0.000000 seconds. The timestamp also resets to zero seconds when the instrument is turned on. It has no effect on the real-time clock.

RESET-RDG#: This menu item is used to reset the reading number to zero. The reading number also resets to zero when the instrument is turned on.

DECIMAL

This menu item lets you select between periods and commas to signify decimal points on the front panel display.

The following options are available for DECIMAL:

PERIOD: This option selects the period (.) as the decimal point for readings.

COMMA: This option selects the comma (,) as the decimal point for readings.

CLOCK

The Model 2002 has a real-time clock that is used for time-stamping bus and buffer readings (real-time timestamp), and as a control source for the Arm Layer (Arm Layer 1). This GENERAL MENU selection is used to set the time date and format (12-hour or 24-hour) for the real time clock.

The menu items for CLOCK are explained as follows:

TIME: This item is used to set the time for the clock. If the 12-hour format is selected, “AM” or “PM” will be displayed. The absence of “AM” or “PM” denotes the 24-hour format. The format for time can be changed with the FORMAT menu item. Use the cursor keys and the range keys to set the time (hours:minutes:seconds).

DATE: This item is used to set the date for the clock. Use the cursor keys and the range keys to set the date. Note that the day of the week (Sun, Mon, etc.) is automatically calculated and displayed for the date.

FORMAT: This item is used to select the time format for the clock:

- **12-HOUR** — With this selection, real-time timestamps for buffer readings are provided in the 12-hour format (AM or PM). Also, the real-time clock control source for the Arm Layer must be set using the 12-hour format.
- **24-HOUR** — With this selection, real-time timestamps for buffer readings are provided in the 24-hour format. Also, the real-time clock control source for the Arm Layer must be set using the 24-hour format.

Note that real-time timestamps for bus readings are always provided in the 24-hour format, regardless of the FORMAT selection.

3

IEEE-488 Reference

3.1 Introduction

This section contains reference information on programming the Model 2002 over the IEEE-488 bus and is organized as follows:

- 3.2 IEEE-488 bus connections:** Explains instrument connections to the IEEE-488 bus.
- 3.3 Primary address selection:** Explains how to set the primary address from the front panel.
- 3.4 QuickBASIC 4.5 programming:** Summarizes programming using QuickBASIC 4.5 with the KPC-488.2 interface and Universal Language Driver (CECHP).
- 3.5 General bus commands:** Covers the general IEEE-488 commands required for basic operations, such as placing the unit in remote.
- 3.6 Front panel aspects of IEEE-488 operation:** Covers status indicators, messages that pertain to bus operation, and the use of the LOCAL key.
- 3.7 Status structure:** Explains the various registers and queues that make up the status structure of the Model 2002.
- 3.8 Trigger model:** Explains the operation process (Trigger Model) over the IEEE-488 bus.
- 3.9 Program message syntax:** Covers the syntax rules for common commands and SCPI commands.
- 3.10 Common commands:** Covers the IEEE-488.2 common commands used by the Model 2002.
- 3.11 SCPI Signal Oriented Measurement Commands:** Covers the signal oriented commands used by the Model 2002.

3.12–3.24 SCPI command subsystems: Covers the SCPI commands used by the Model 2002.

The IEEE-488 is an instrumentation data bus with hardware and programming standards originally adopted by the IEEE (Institute of Electrical and Electronic Engineers) in 1975 and given the IEEE-488 designation. In 1978 and 1987, the standards were upgraded to IEEE-488-1978 and IEEE-488.1-1987, respectively. The Model 2002 conforms to these standards.

The Model 2002 also conforms to the IEEE-488.2-1987 standard and the SCPI 1991 (Standard Commands for Programmable Instruments) standard. IEEE-488.2 defines a syntax for sending data to and from instruments, how an instrument interprets this data, what registers should exist to record the state of the instrument, and a group of common commands. The SCPI standard defines a command language protocol. It goes one step farther than IEEE-488.2 and defines a standard set of commands to control every programmable aspect of an instrument.

3.2 IEEE-488 bus connections

The Model 2002 can be connected to the IEEE-488 bus through a cable equipped with standard IEEE-488 connectors, an example is shown in Figure 3-1. The connector can be stacked to allow a number of parallel connections to one instrument. Two screws are located on each connector to ensure that connections remain secure. Current standards call for metric threads, which are identified with dark colored screws. Earlier versions had different screws, which were silver colored. Do not attempt to use these type of connectors on the instrument, which is designed for metric threads.

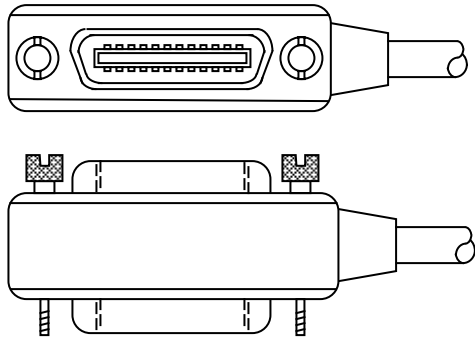

Figure 3-1
IEEE-488 connector

A typical connecting scheme for a multi-unit test system is shown in Figure 3-2. Although any number of connectors could theoretically be stacked on one instrument, it is recommended that you stack no more than three connectors on any one unit to avoid possible mechanical damage.

NOTE

In order to minimize interference caused by electromagnetic radiation, it is recommended that only shielded IEEE-488 cables be used. The Models 7007-1 and 7007-2 shielded IEEE-488 cables are available from Keithley.

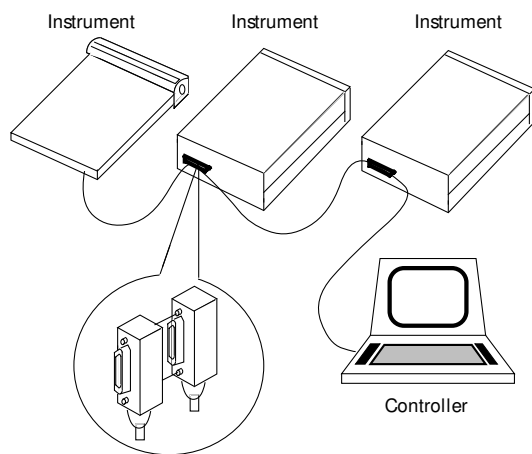

Figure 3-2
IEEE-488 connections

Connect the Model 2002 to the IEEE-488 bus as follows:

1. Line up the cable connector with the connector located on the rear panel. The connector is designed so that it

will fit only one way. Figure 3-3 shows the location of the IEEE-488 connector on the instrument.

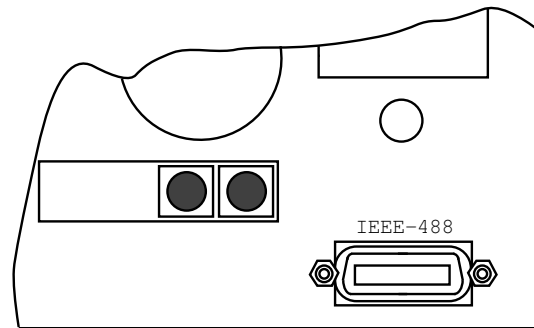

Figure 3-3
IEEE-488 connector location

2. Tighten the screws securely, but do not overtighten them.
3. Add additional connectors from other instruments, as required.
4. Make certain that the other end of the cable is properly connected to the controller. Most controllers are equipped with an IEEE-488 style connector, but a few may require a different type of connecting cable. Consult the instruction manual for your controller for the proper connecting method.

NOTE

The IEEE-488 bus is limited to a maximum of 15 devices, including the controller. The maximum cable length is 20-meters, or two meters times the number of devices, whichever is less. Failure to observe these limits may result in erratic bus operation.

3.3 Primary address selection

The Model 2002 is shipped from the factory with a programmed primary address of 16. The primary address may be set to any value between 0 and 30 as long as address conflicts with other instruments are avoided. Note that controllers are also given a primary address, so do not use that address either. Most frequently, controller addresses are 0 or 21, but you should consult the controller's instruction manual for details. Whatever primary address you choose, you must make certain that it corresponds with the value specified as part of the controller's programming language.

To check the present primary address or to change to a new one, perform the following procedure:

1. Display the MAIN MENU by pressing the MENU key.
2. Use the cursor keys (◀ and ▶) to place the cursor on GPIB and press ENTER. The GPIB/PRINTER SETUP menu will then be displayed.
3. Use the cursor keys to place the cursor on ADDRESS-ABLE and press ENTER.
4. The current primary address of the instrument will be displayed. For example, if the instrument is set to primary address 16, the following message will be displayed:

ADDRESS = 16 (0-30)

5. To retain the displayed address, press EXIT three times to return the instrument to the measurement display state.
6. To change the primary address, use the ◀ and ▶ keys and the ▲ and ▼ keys to display the new address value (0 to 30). The ◀ and ▶ keys control cursor position and the ▲ and ▼ keys increment and decrement the selected digit.
7. With the desired address value displayed, press ENTER. The address will be stored in non-volatile memory. That is, it will not be lost when the instrument is turned off.
8. Press EXIT two times to return to the measurement display state.

NOTE

Each device on the bus must have a unique primary address. Failure to observe this precaution will probably result in erratic bus operation.

3.4 QuickBASIC 4.5 programming

Programming examples are written in Microsoft QuickBASIC 4.5 using the Keithley KPC-488.2 (or Capital Equipment Corporation) IEEE interface and the HP-style Universal Language Driver (CECHP).

Before any programming example can be run, the Universal Language Driver must first be installed. From DOS, execute the following command to install the driver:

```
cechp
```

If you include the CECHP command in your AUTOEXEC.BAT file, the driver will automatically be installed every time you turn on your computer.

Program fragments

Program fragments are used extensively throughout this manual to demonstrate proper programming syntax. As the name implies, only a fragment of the whole program is used in order to avoid redundancy.

At the beginning of each program, driver files have to be opened and the input terminator should be set for CRLF.

```
OPEN "ieee" FOR OUTPUT AS #1
OPEN "ieee" FOR INPUT AS #2
PRINT #1, "interm crlf"
```

A typical program fragment includes an OUTPUT command and an ENTER command. The OUTPUT command sends a program message (command string) to the Model 2002. If the program message includes a query command, then the ENTER command is required to get the response message from the Model 2002. The ENTER command addresses the Model 2002 to talk. The following example program fragment demonstrates how OUTPUT and ENTER are used. Note that the commands assume address 16 which is the factory set address of the Model 2002.

```
PRINT #1, "output 16; :func 'volt:ac'; func?"
PRINT #1, "enter 16"
```

If you wish to display the response message on the CRT, the computer will have to read the message and then "print" it to the CRT display as follows:

```
LINE INPUT #2, A$
PRINT A$
```

The following programming example shows how all the above statements are used together. The program fragment is shown in bold typeface.

```
OPEN "ieee" FOR OUTPUT AS #1 ' Open driver
OPEN "ieee" FOR INPUT AS #2 ' Open driver
PRINT #1, "interm crlf" ' CRLF terminator
' Select ACV and query
PRINT #1, "output 16; :func 'volt:ac'; func?"
PRINT #1, "enter 16" ' Get response message
LINE INPUT #2, A$ ' Read response message
PRINT A$ ' Display message
```

3.5 General bus commands

General bus commands are those commands such as DCL that have the same general meaning regardless of the instrument. Table 3-1 lists the general bus commands. Also included is the programming statement for each command using the Keithley KPC-488.2 IEEE interface and the HP-style Universal Language Driver (CECHP). Note that the commands requiring that a primary address be specified assume that the address is set to 16. This is the address that is set at the factory.

3.5.1 REN (remote enable)

The remote enable command is sent to the Model 2002 by the controller to set up the instrument for remote operation. Generally, the instrument should be placed in the remote mode before you attempt to program it over the bus. Simply setting REN true does not actually place the instrument in the remote state. Instead the instrument must be addressed to listen after setting REN true before it goes into remote.

Note that the instrument need not be in remote to be a talker.

Program fragment

```
PRINT #1, "remote 16" ' Place 2002 in remote;
                    ' turn on REM annunciator
```

Note that all front panel controls except for LOCAL (and POWER) are inoperative while the instrument is in remote. You can restore normal front panel operation by pressing the LOCAL key.

3.5.2 IFC (interface clear)

The IFC command is sent by the controller to place the Model 2002 in the local, talker, and listener idle states. The unit responds to the IFC command by cancelling front panel TALK or LISTEN lights, if the instrument was previously placed in one of those states.

Note that this command does not affect the status of the instrument; settings, data, and event registers are not changed.

To send the IFC command, the controller need only set the IFC line true for a minimum of 100µsec.

Program fragment

```
PRINT #1, "output 16; *idn?" ' Send query command
PRINT #1, "enter 16"       ' Read data; turn on
                           ' TALK annunciator
SLEEP 3                    ' Wait 3 seconds
PRINT #1, "abort"         ' Talker idle state;
                           ' turn off TALK annun-
                           ' ciator
```

3.5.3 LLO (local lockout)

The LLO command is used to prevent local operation of the instrument. After the unit receives LLO, all its front panel controls except POWER are inoperative. In this state, pressing LOCAL will not restore control to the front panel. The GTL command restores control to the front panel.

Program fragment

```
PRINT #1, "remote 16" ' Place 2002 in remote
RINT #1, "local lockout" ' Lock out front panel
                        ' (including LOCAL key)
SLEEP 6                ' Wait 6 seconds
PRINT #1, "local 16" ' Restore front panel op-
                        ' eration
```

Table 3-1

General bus commands and associated statements

Command	Programming statement	Effect on Model 2002
REN	REMOTE 16	Goes into effect when next addressed to listen.
IFC	ABORT	Goes into talker and listener idle states.
LLO	LOCAL LOCKOUT	LOCAL key locked out.
GTL	LOCAL 16	Cancel remote, restore front panel operation for 2002.
	LOCAL	Cancel remote, restore front panel operation for all devices.
DCL	CLEAR	Returns all devices to known conditions.
SDC	CLEAR 16	Returns Model 2002 to known conditions.
GET	TRIGGER 16	Initiates a trigger.
SPE, SPD	SPOLL 16	Serial Polls the Model 2002.

3.5.4 GTL (go to local)

The GTL command is used to take the instrument out of the remote state. Operation of the front panel keys will also be restored by GTL.

Program fragment

```
PRINT #1, "remote 16" ' Place 2002 in remote
SLEEP 3              ' Wait 3 seconds
PRINT #1, "local 16" ' Take 2002 out of remote
```

3.5.5 DCL (device clear)

The DCL command may be used to clear the IEEE GPIB interface and return it to a known state. Note that the DCL command is not an addressed command, so all instruments equipped to implement DCL will do so simultaneously.

When the Model 2002 receives a DCL command, it clears the Input Buffer and Output Queue, cancels deferred commands, and clears any command that prevents the processing of any other device command. A DCL does not affect instrument settings and stored data.

Program fragment

```
PRINT #1, "clear" ' Clear all devices
```

3.5.6 SDC (selective device clear)

The SDC command is an addressed command that performs essentially the same function as the DCL command. However, since each device must be individually addressed, the SDC command provides a method to clear only selected instruments instead of clearing all instruments simultaneously, as is the case with DCL.

Program fragment

```
PRINT #1, "clear 16" ' Clear 2002
```

3.5.7 GET (group execute trigger)

GET is a GPIB trigger that is used as an arm, scan and/or measure event to control operation. The Model 2002 will react to this trigger if it is the programmed control source. GET can also be used as the pre-trigger for the reading buffer. The control source is programmed from the SCPI :TRIGGER subsystem.

With the instrument programmed and waiting for a GPIB trigger, the following program fragment will provide the GET.

Program fragment

```
PRINT #1, "trigger 16" ' Trigger 2002 from over
                        ' the bus
```

This sends IEEE-488 commands UNT UNL LISTEN 16 GET. When the command is executed, the trigger event occurs. (The command TRIGGER just sends GET. Any other listeners are triggered when the command is executed.)

3.5.8 SPE, SPD (serial polling)

The serial polling sequence is used to obtain the Model 2002 serial poll byte. The serial poll byte contains important information about internal functions, as described in paragraph 3.7.6. Generally, the serial polling sequence is used by the controller to determine which of several instruments has requested service with the SRQ line. However, the serial polling sequence may be performed at any time to obtain the status byte from the Model 2002.

Program fragment

```
PRINT #1, "spoll 16" ' Serial poll the 2002
INPUT #2, S          ' Read the serial poll byte
PRINT S              ' Display the decimal value of
                    ' the serial poll byte
```

3.6 Front panel aspects of IEEE-488 operation

The following paragraphs discuss aspects of the front panel that are part of IEEE-488 operation, including messages, status indicators, and the LOCAL key.

3.6.1 Error and status messages

Table 2-4 summarizes the error and status messages associated with IEEE-488 programming. Note that the instrument may be programmed to generate an SRQ, and command queries can be performed to check for specific error conditions.

3.6.2 IEEE-488 status indicators

The REM (remote), TALK (talk), LSTN (listen), and SRQ (service request) annunciators show the present IEEE-488 status of the instrument. Each of these indicators is briefly described below.

REM — This indicator shows when the instrument is in the remote state. Note that REM does not necessarily indicate the state of the REN line, as the instrument must be addressed to listen with REN true before the REM indicator

turns on. When the instrument is in remote, all front panel keys except for the LOCAL key are locked out. When REM is turned off, the instrument is in the local state, and front panel operation is restored.

TALK — This indicator is on when the instrument is in the talker active state. The unit is placed in this state by addressing it to talk with the correct MTA (My Talk Address) command. TALK is off when the unit is in the talker idle state. The instrument is placed in the talker idle state by sending it an UNT (Untalk) command, addressing it to listen, or with the IFC (Interface Clear) command.

LSTN — This indicator is on when the Model 2002 is in the listener active state, which is activated by addressing the instrument to listen with the correct MLA (My Listen Address) command. Listen is off when the unit is in the listener idle state. The unit can be placed in the listener idle state by sending UNL (Unlisten), addressing it to talk, or by sending IFC (Interface Clear) over the bus.

SRQ — The instrument can be programmed to generate a service request (SRQ) when one or more errors or conditions occur. When this indicator is on, a service request has been generated. This indicator will stay on until the serial poll byte

is read or all the conditions which caused SRQ have ceased to exist. See paragraph 3.7.6 for details.

3.6.3 LOCAL key

The LOCAL key cancels the remote state and restores local operation of the instrument.

Pressing LOCAL also turns off the REM indicator and returns the display to normal if a user defined message was displayed.

Note that the LOCAL key is also inoperative if the LLO (Local Lockout) command is in effect.

3.7 Status structure

The status structure for the Model 2002 is summarized in Figure 3-4. Instrument events, such as errors, are monitored and manipulated by seven status register sets. Notice that these seven status register sets feed directly or indirectly into the Status Byte Register. More detailed illustrations of these register sets are provided by Figures 3-5 through 3-11.

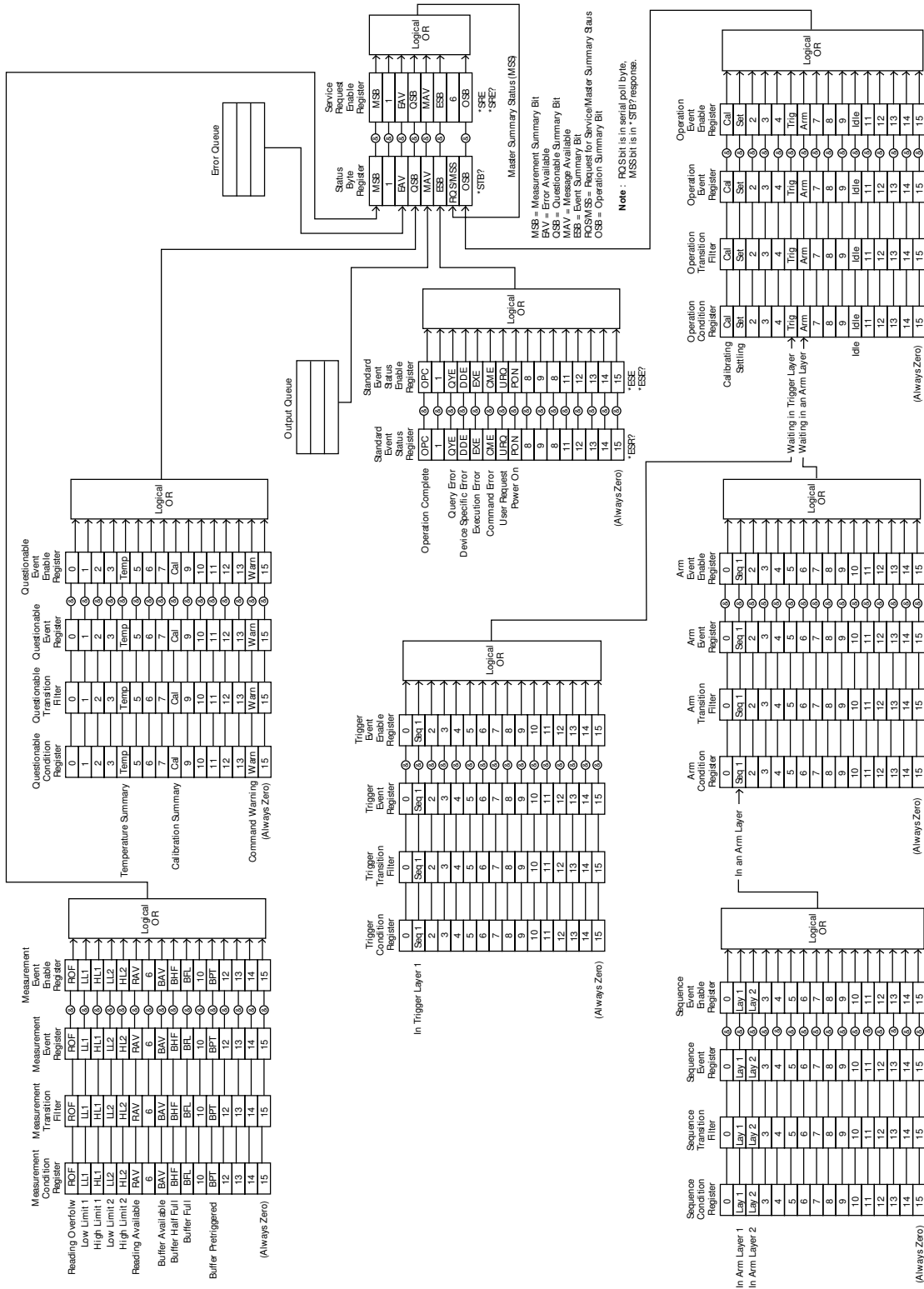

Figure 3-4 Model 2002 status register structure

3.7.1 Condition registers

As shown in the illustrations, all status register sets, except the standard event status register set, have a condition register. A condition register is a real-time read-only register that constantly updates to reflect the current operating conditions of the instrument. For example, while a calculation is being performed, bit B9 (Calc) of the Operation Condition Register is set. When the calculation is completed, bit B9 clears.

The :CONDition? query commands in the STATus Subsystem are used to read the condition registers. See paragraph 3.20 for details.

3.7.2 Transition filters

As shown in the illustrations, all status register sets, except the standard event status register set, have a transition filter. A transition filter is made up of two registers that are programmed by the user. It is used to specify which transition (0 to 1, or 1 to 0) in the corresponding condition register will set the corresponding bit in the event register.

A filter can be programmed for positive transitions (PTR), negative transitions (NTR) or both. When an event is programmed for a positive transition, the corresponding bit in the event register sets when the corresponding bit in the condition register changes for 0 to 1. Conversely, when programmed for a negative transition, the bit in the event register sets when the corresponding bit in the condition register changes from 1 to 0.

The :PTR and :NTR commands in the Status Subsystem are used to set or clear the individual bits of the transition filter registers, while the :PTR? and :NTR? query commands are used to read the registers (see paragraph 3.20 for details). Reading a transition filter register does not affect its bit pattern.

The following operations set (1) all bits of all PTR registers and clear (0) all bits of all NTR registers:

- Cycling power
- Sending :STATus:PRESet

3.7.3 Event registers

As shown in the illustrations, each status register set has an event register. An event register is a latched, read-only register whose bits are set by the corresponding condition register and transition filter. Once a bit in an event register is set, it remains set (latched) until the register is cleared by a specific

clearing operation. The bits of an event register are logically ANDed with the bits of the corresponding enable register and applied to an OR gate. The output of the OR gate is applied to another register set or to the Status Byte Register.

The *ESR? Common Command is used to read the Standard Event Register (see paragraph 3.10.3). All other event registers are read using the [:EVENT]? query commands in the STATus Subsystem (see paragraph 3.20).

An event register is cleared when it is read. The following operations clear all event registers:

- Cycling power
- Sending *CLS

3.7.4 Enable registers

As shown in the illustrations, each status register set has an enable register. An enable register is programmed by the user and serves as a mask for the corresponding event register. An event bit is masked when the corresponding bit in the enable register is cleared (0). When masked, a set bit in an event register cannot set a bit in a following register set or in the Status Byte Register ($1 \text{ AND } 0 = 0$).

To use the Status Byte Register to detect events (i.e. serial poll), you must unmask the events by setting (1) the appropriate bits of the enable registers.

The Standard Event Status Enable Register is programmed and queried using the *ESE and *ESE? Common Commands respectively (see paragraph 3.10.2). All other enable registers are programmed and queried using the :ENABLE and :ENABLE? commands in the STATus Subsystem (see paragraph 3.20).

An enable register is not cleared when it is read. The Enable registers are affected by the following operations:

- Cycling power – Clears all enable registers
- :STATus:PRESet clears the following enable registers:
Operation Event Enable Register
Questionable Event Enable Register
Measurement Event Enable Register
- :STATus:PRESet sets all bits of the following enable registers:
Trigger Event Enable Register
Arm Event Enable Register
Sequence Event Enable Register
- *ESE 0 – Clears the Standard Event Status Enable Register.

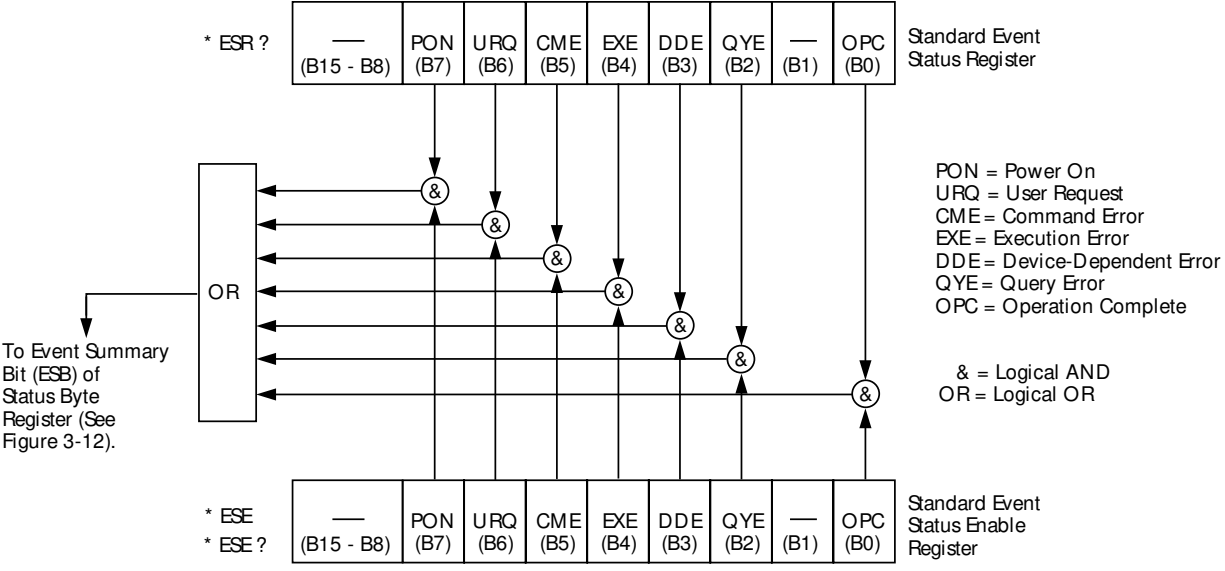

Figure 3-5
Standard event status

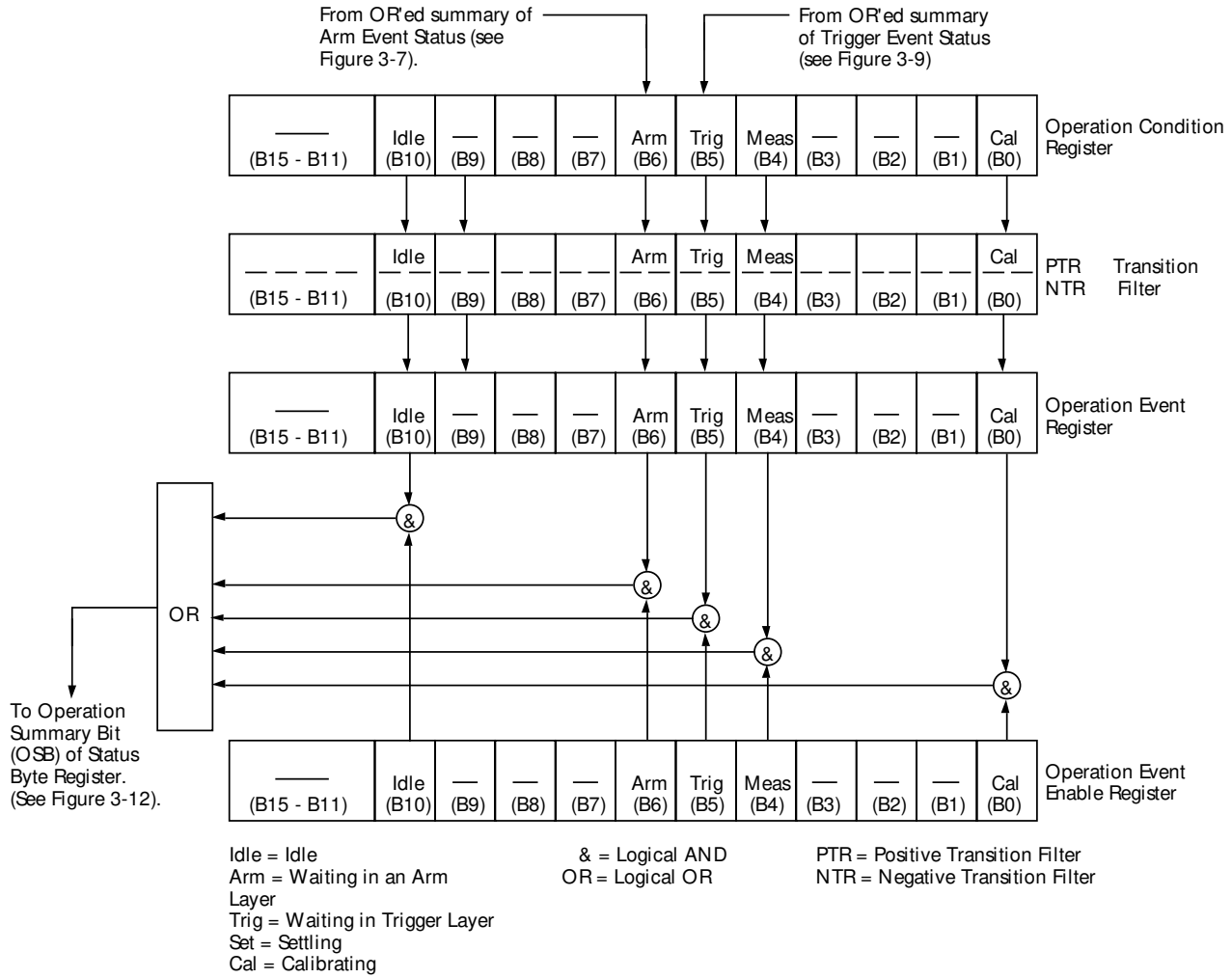
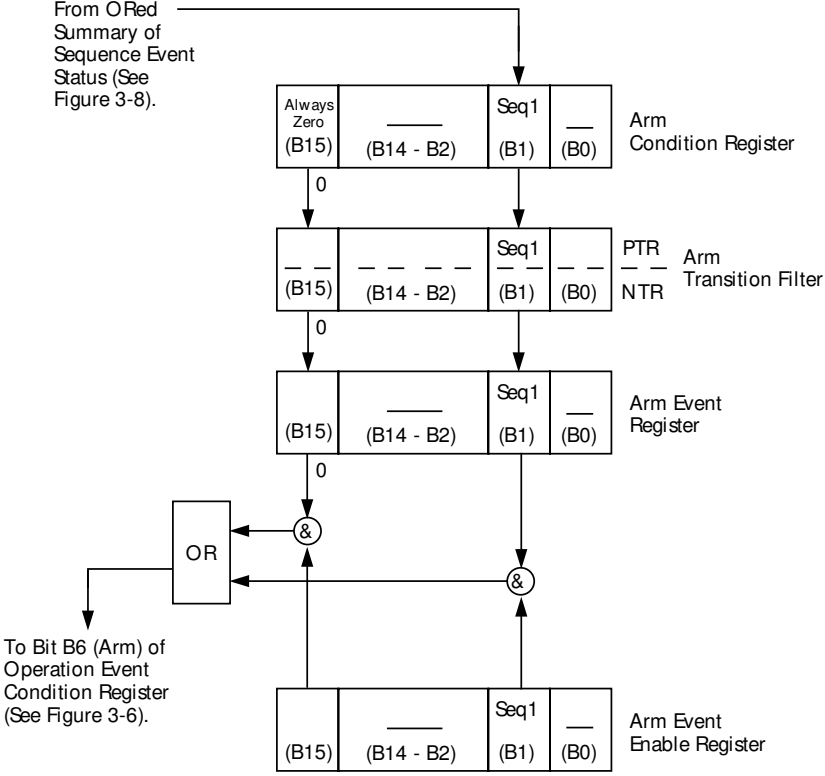

Figure 3-6
Operation event status



Seq 1 = Sequence 1 (Set bit indicates that the 2001 is in the arm layer of Sequence 1)

& = Logical AND
OR = Logical OR
PTR = Positive Transition Register
NTR = Negative Transition Register

Figure 3-7
Arm event status

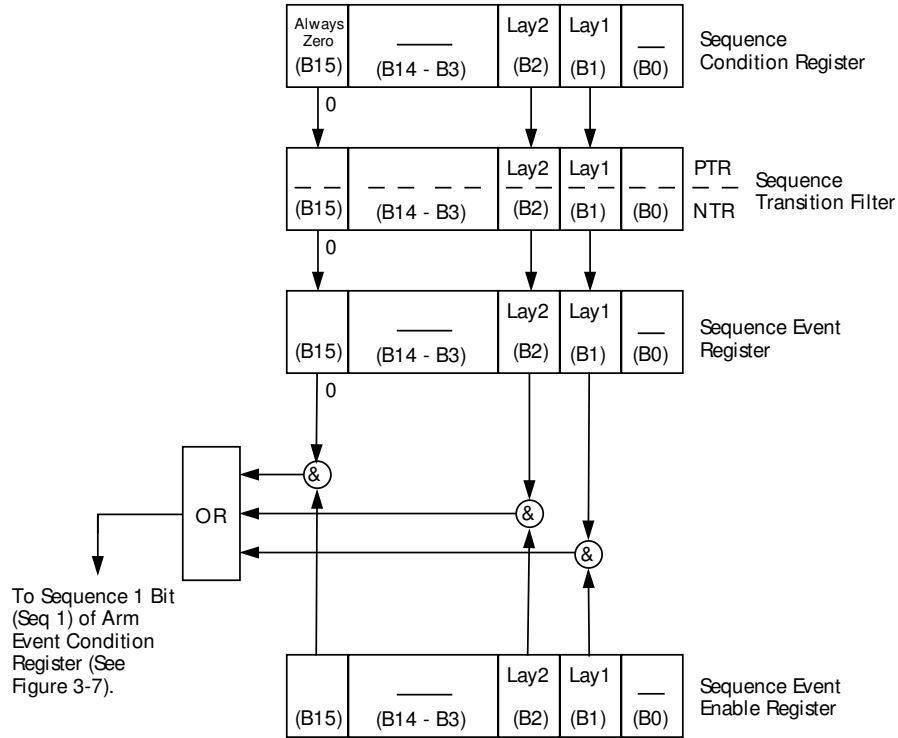

Lay1 = Layer 1 (Set bit indicates that 2002 is in arm layer 1).
 Lay2 = Layer 2 (Set bit indicates that 2002 is in arm layer 2).

& = Logical AND
 OR = Logical OR
 PTR = Positive Transition Register
 NTR = Negative Transition Register

Figure 3-8
 Sequence event status

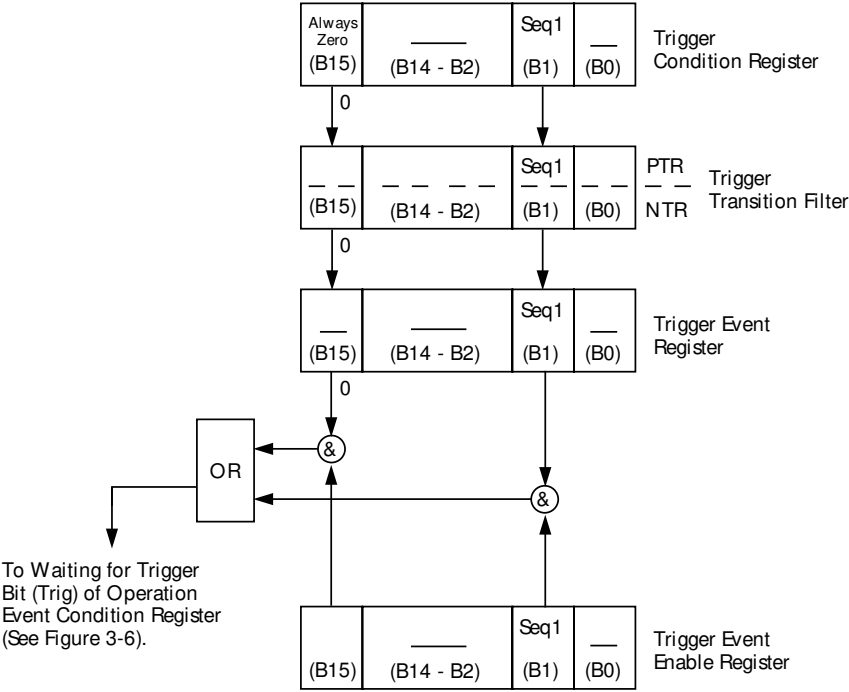

Seq 1 = Sequence 1 (Set bit indicates that the 2002 is in the trigger layer of Sequence 1)

& = Logical AND
OR = Logical OR
PTR = Positive Transition Register
NTR = Negative Transition Register

Figure 3-9
Trigger event status

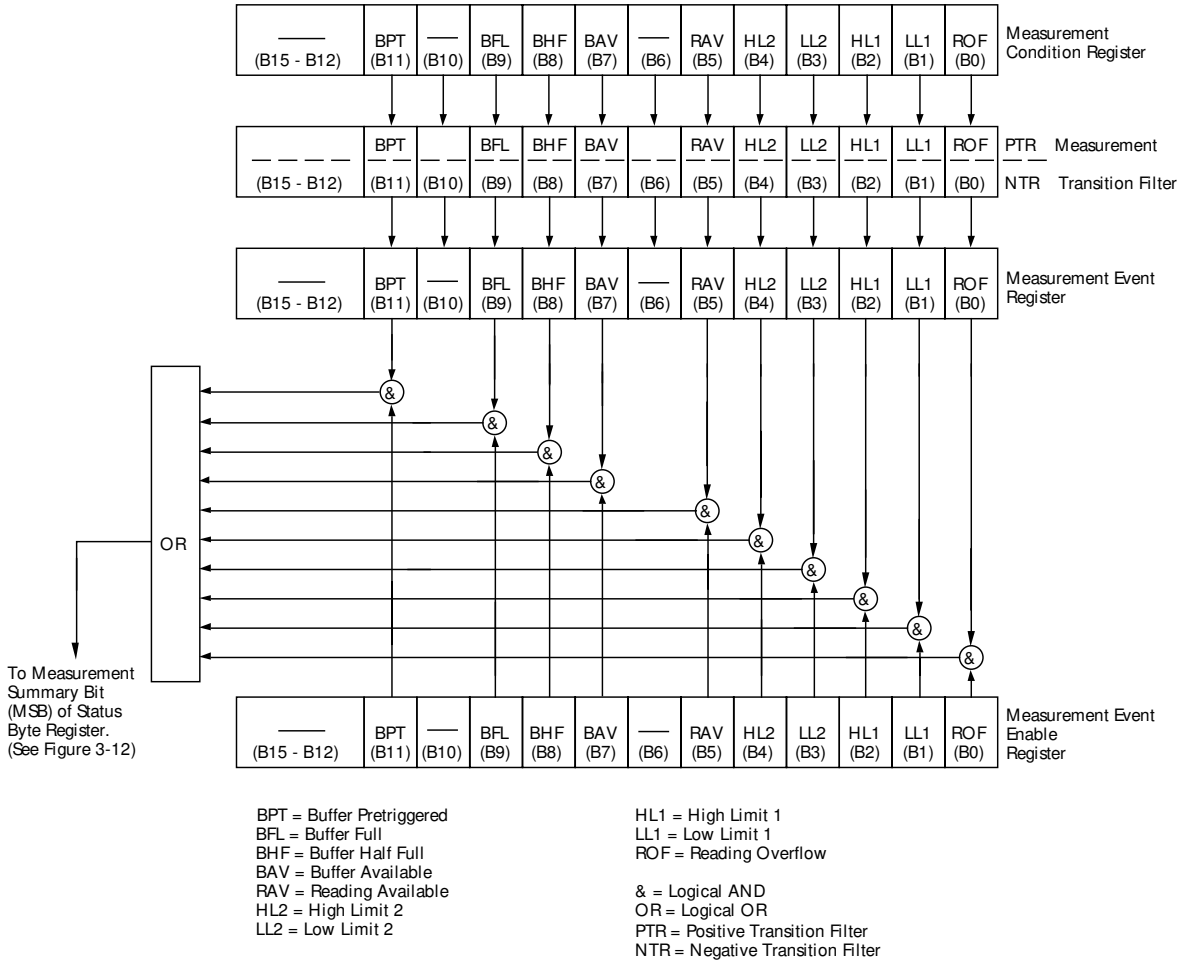
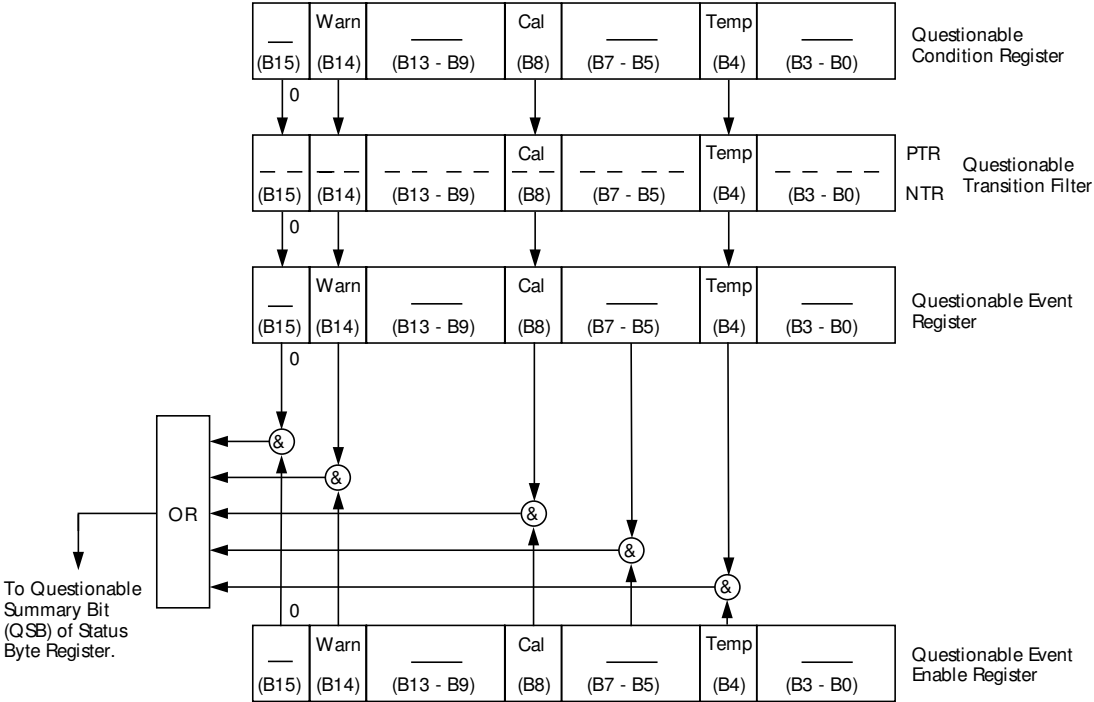

Figure 3-10
Measurement event status



Warn = Command Warning
Cal = Calibration Summary
Temp = Temperature Summary

& = Logical AND
OR = Logical OR
PTR = Positive Transition Register
NTR = Negative Transition Register

Figure 3-11
Questionable event status

3.7.5 Queues

The Model 2002 uses two queues; the Output Queue and the Error Queue. The queues are first-in first-out (FIFO) registers. The Output Queue is used to hold readings and response messages, and the Error Queue is used to hold error messages and status messages. The Model 2002 status model (Figure 3-4) shows how the two queues are structured with the other registers.

Output Queue — The Output Queue is used to hold data that pertains to the normal operation of the instrument. For example, when a query command is sent, the response message is placed in the Output Queue.

When data is placed in the Output Queue, the Message Available (MAV) bit in the Status Byte Register sets. A data message is cleared from the Output Queue when it is read. The Output Queue is considered cleared when it is empty. An empty Output Queue clears the MAV bit in the Status Byte Register.

A message from the Output Queue is read by addressing the Model 2002 to talk after the appropriate query is sent.

Error Queue — The Error Queue is used to hold error messages and status messages. When an error or status event occurs, a message that defines the error/status is placed in the Error Queue. This queue will hold up to 10 messages.

When a message is placed in the Error Queue, the Error Available (EAV) bit in the Status Byte Register is set. An error message is cleared from the Error/Status Queue when it is read. The Error Queue is considered cleared when it is empty. An empty Error Queue clears the EAV bit in the Status Byte Register. An error message from the Error Queue is read by sending either of the following SCPI query commands and then addressing the Model 2002 to talk:

```
:SYSTem:ERRor?  
:STATus:QUEue?
```

Refer to paragraphs 3.20.7 (:STATus:QUEue?) and 3.21.5 (:SYSTem:ERRor?) for complete information on reading error messages.

3.7.6 Statusbyte and service request (SRQ)

Service request is controlled by two 8-bit registers; the Status Byte Register and the Service Request Enable Register. The structure of these registers is shown in Figure 3-12.

Status Byte Register — The summary messages from the status registers and queues are used to set or clear the appropriate bits (B0, B2, B3, B4, B5 and B7) of the Status Byte Register. These bits do not latch and their states (0 or 1) are solely dependent on the summary messages (0 or 1). For example, if the Standard Event Status Register is read, its register will clear. As a result, its summary message will reset to 0, which in turn will clear the ESB bit in the Status Byte Register.

Bit B6 in the Status Byte Register is either:

- The Master Summary Status (MSS) bit, sent in response to the *STB? command, indicates the status of any set bits with corresponding enable bits set.
- The Request for Service (RQS) bit, sent in response to a serial poll, indicates which device was requesting service by pulling on the SRQ line.

For description of the other bits in the Status Byte Register, refer to paragraph 3.10.12.

The IEEE-488.2 standard uses the following common query command to read the Status Byte Register:

```
*STB?
```

When reading the Status Byte Register using the *STB? command, bit B6 is called the MSS bit. None of the bits in the Status Byte Register are cleared when using the *STB? command to read it.

The IEEE-488.1 standard has a serial poll sequence that also reads the Status Byte Register and is better suited to detect a service request (SRQ). When using the serial poll, bit B6 is called the RQS bit. Serial polling causes bit B6 (RQS) to reset. Serial polling is discussed in more detail later in this paragraph (see “Serial Poll and SRQ”).

Any of the following operations clear all bits of the Status Byte Register:

- Cycling power.
- Sending the *CLS common command.

NOTE

The MAV bit may or may not be cleared.

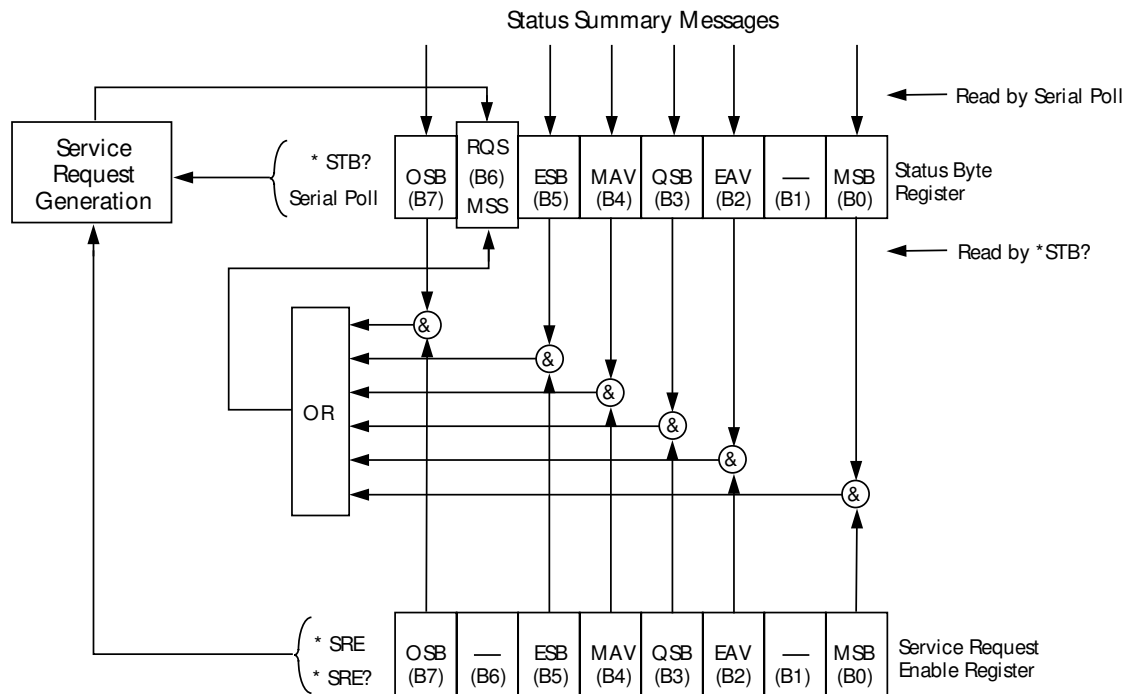

OSB = Operation Summary Bit
MSS = Master Summary Status
RQS = Request for Service
ESB = Event Summary Bit
MAV = Message Available
QSB = Questionable Summary Bit
EAV = Error Available
MSB = Measurement Summary Bit

& = Logical AND
OR = Logical OR

Figure 3-12
Status byte and service request (SRQ)

Service Request Enable Register — This register is programmed by the user and serves as a mask for the Status Summary Message bits (B0, B2, B3, B4, B5 and B7) of the Status Byte Register. When masked, a set summary bit in the Status Byte Register cannot set bit B6 (MSS/RQS) of the Status Byte Register. Conversely, when unmasked, a set summary bit in the Status Byte Register sets bit B6.

A Status Summary Message bit in the Status Byte Register is masked when the corresponding bit in the Service Request Enable Register is cleared (0). When the masked summary bit in the Status Byte Register sets, it is ANDed with the cor-

responding cleared bit in the Service Request Enable Register. The logic “0” output of the AND gate is applied to the input of the OR gate and thus, will not set the MSS/RQS bit in the Status Byte Register.

A Status Summary Message bit in the Status Byte Register is unmasked when the corresponding bit in the Service Request Enable Register is set (1). When the unmasked summary bit in the Status Byte Register sets, it is ANDed with the corresponding set bit in the Service Request Enable Register. The logic “1” output of the AND gate is applied to the input of the OR gate and thus, sets the MSS/RQS bit in the Status Byte Register.

The individual bits of the Service Request Enable Register can be set or cleared by using the following common command (see paragraph 3.10.11 for details):

```
*SRE <Nrf>
```

The Service Request Enable Register can be read using the following common query command (see paragraph 3.10.11 for details):

```
*SRE?
```

The Service Request Enable Register is not cleared when it is read using the *SRE? query command. The Service Request Enable Register clears when power is cycled or a parameter (n) value of zero is sent with the *SRE command (*SRE 0).

Serial poll and SRQ

Any enabled event summary bit that goes from 0 to 1 will set RQS and generate a service request (SRQ). The user's test program can periodically read the Status Byte Register to check to see if a service request (SRQ) has occurred and what caused it. In the event of an SRQ, the program can, for example, branch to an appropriate subroutine that will service the request. Typically, service requests (SRQs) are managed by the serial poll sequence of the Model 2002. If an SRQ does not occur, bit B6 (RQS) of the Status Byte Register will remain cleared and the program will simply proceed normally after the serial poll is performed. If an SRQ does occur, bit B6 of the Status Byte Register will set and the program can branch to a service subroutine when the SRQ is detected by the serial poll.

The serial poll automatically resets RQS of the Status Byte Register. This will allow subsequent serial polls to monitor Bit 6 for an SRQ occurrence generated by other event types. After a serial poll, the same event can cause another SRQ, even if the event register which caused the first SRQ has not been cleared.

A serial poll clears RQS but does not clear MSS. The MSS bit will stay set until all Status Byte event summary bits are cleared.

The following QuickBASIC 4.5 program (using the KPC-488.2 interface and the CECHP driver) demonstrates how serial poll can be used to detect an SRQ.

```
CLS
OPEN "ieee" FOR OUTPUT AS #1
OPEN "ieee" FOR INPUT AS #2
PRINT #1, "output 16; *cls"      ' Clear Status Byte
                                ' Register
PRINT #1, "output 16; *ese 32"  ' Unmask command
                                ' errors
PRINT #1, "output 16; *sre 32"  ' Unmask event sum-
                                ' mary message
PRINT #1, "output 16; *ese"     ' Error - missing
                                ' parameter

SLEEP 1
PRINT #1, "SPOLL 16"           ' Serial poll 2002
INPUT #2, S                    ' Read Status Byte
                                ' Register
S = S OR 191                   ' OR register with a
                                ' mask

IF S = 255 THEN
GOSUB srq                      ' Go to subroutine
                                ' to acknowledge
                                ' SRQ

END IF
PRINT
END

srq:
PRINT "SRQ Has Occurred - RQS (bit B6) is set (1)"
RETURN
```

3.8 Trigger model (IEEE-488 operation)

The following information describes the operation process of the Model 2002 over the IEEE-488 bus. The flowchart in Figure 3-13, which summarizes operation over the bus, is called the Trigger model. It is called the trigger model because operation is controlled by SCPI commands from the Trigger subsystem (see paragraph 3.23. Notice that key SCPI commands are included in the trigger model.

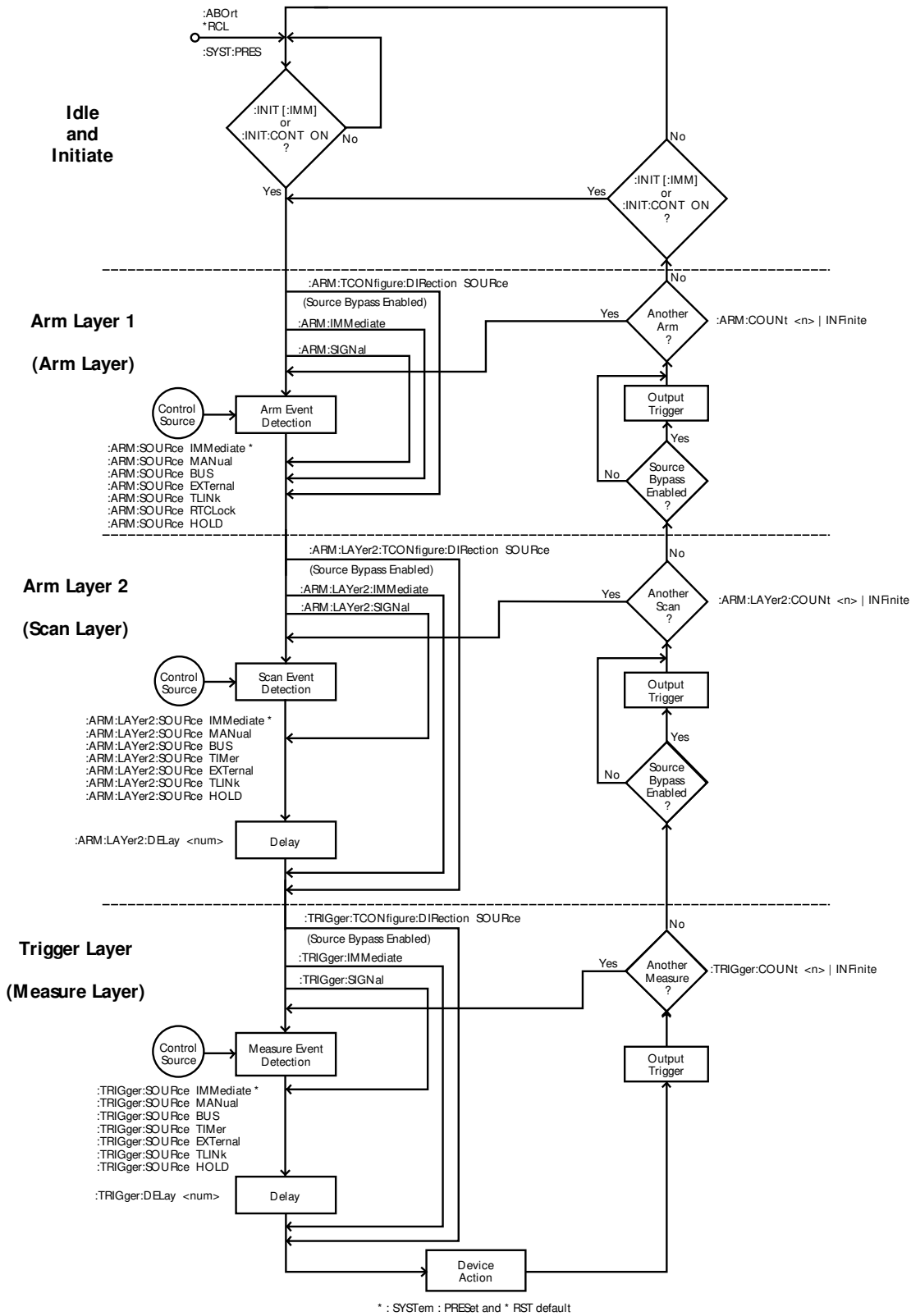

Figure 3-13
Trigger Model (IEEE-488 bus operation)

Idle and initiate

The instrument is considered to be in the idle state whenever it is not operating within one of the layers of the trigger model. The front panel ARM indicator is off when the instrument is in the idle state. While in the idle state, the instrument cannot perform any measure or scan functions. Over the bus, there are two SCPI commands that can be used to take the instrument out of the idle state; :INITiate or :INITiate:CONTinuous ON.

Notice that with continuous initiation enabled (:INIT:CONT ON), the instrument will not remain in the idle state after all programmed operations are completed. However, the instrument can be returned to the idle state at any time by sending the *RST command, the *RCL command, or the SYST:PRES command.

Trigger model layers

As can be seen in Figure 3-13, the trigger model uses three layers; Arm Layer1, Arm Layer 2 and the Trigger Layer. For front panel operation, these layers are known as the Arm Layer, Scan Layer and Measure Layer.

Once the Model 2002 is taken out of the idle state, operation proceeds through the layers of the trigger model down to the device action where a measurement occurs.

Control sources — In general, each layer contains a control source which holds up operation until the programmed event occurs. The control sources are summarized as follows:

- **IMMediate** — With this control source selected, event detection is immediately satisfied allowing operation to continue.
- **MANual** — Event detection is satisfied by pressing the TRIG key. Note that the Model 2002 must be taken out of remote before it will respond to the TRIG key. Press LOCAL or send LOCAL 16 over the bus to take the instrument out of remote.
- **BUS** — Event detection is satisfied when a bus trigger (GET or *TRG) is received by the Model 2002.
- **TIMer** — Event detection is immediately satisfied on the initial pass through the layer. Each subsequent detection is satisfied when the programmed timer interval (1 to 999999.999 seconds) elapses. A timer resets to its initial state when operation loops back to a higher layer (or idle). Note that TIMer is not available in Arm Layer 1.
- **EXTernal** — Event detection is satisfied when an input trigger via the EXTERNAL TRIGGER connector is received by the Model 2002.

- **TLINK** — Event detection is satisfied when an input trigger via the TRIGGER LINK is received by the Model 2002.
- **RTCLOCK** — Event detection is satisfied when the programmed time and date occurs. Note that the real-time clock is only available as a control source for Arm Layer 1.
- **HOLD** — With this selection, event detection is not satisfied by any of the above control source events and operation is held up.

Control source loops — As can be seen in the flowchart, each layer has three paths that allow operation to loop around the control source. These three paths are described as follows:

- **:DIRection (Source Bypass)** — When a source bypass is enabled (:DIRection SOURce) and the EXTernal or TLINK control source is selected, operation will loop around the control source on the initial pass through the layer. If programmed for another event detection in the layer, the bypass loop will not be in effect even though it is still enabled. The bypass loop resets (be in effect) if operation loops back to a higher layer (or idle).

In Arm Layer 1 and Arm Layer 2, enabling a source bypass also enables the respective output trigger. In the Trigger Layer, its output trigger is always enabled and occurs after every device action. See Output Triggers for more information.

- **:IMMediate** — Each time an :IMMediate command is sent, operation loops around the respective control source. It is used when you do not wish to wait for the programmed event to occur (or when the HOLD control source is selected). Note that in Arm Layer 1 and the Trigger Layer, :IMMediate also loops operation around the delays.
- **:SIGNal** — Same function as an :IMMediate command.

Delays — Arm Layer 2 and the Trigger Layer have a programmable Delay (0 to 999999.999 seconds) that is asserted after an event detection. Note, however, that a Delay can be bypassed by sending an :IMMediate or :SIGNal command.

Device Action — The primary device action is a measurement. However, the device action could include a function change and a channel scan (if scanner is enabled). A channel is scanned (closed) before a measurement is made. When scanning internal channels, the previous channel opens and the next channel closes (break-before-make). Also included in the device action is the internal settling time delay for the relay.

Output Triggers — In Arm Layers 1 and 2, the output triggers are enabled only if their respective source bypasses are also enabled. If a TLINK control source is selected, the output trigger pulse is available on the selected TRIGGER LINK output line. For all other control source selections, the trigger pulse is available at the METER COMPLETE connector.

In the Trigger Layer, the output trigger is always enabled and occurs after every device action. If the control source is set for EXTERNAL, IMMEDIATE, MANUAL, BUS or TIMER, the output trigger pulse is available at the METER COMPLETE connector. If the TLINK control source is selected, output trigger action occurs on the selected TRIGGER LINK output line as follows:

- If the asynchronous Trigger Link mode is selected, the output trigger pulse is available on the programmed output line.

- If the semi-synchronous Trigger Link mode is selected and the source bypass is disabled (:trig:tcon:dir acc), the Trigger Link line is released (goes high).
- If the semi-synchronous Trigger Link mode is selected and the Source Bypass is enabled (:trig:tcon:dir sour), the Trigger Link line is pulled down low and then released.

Counters — All three layers use programmable counters which allow operation to return to or stay in the respective layer. For example, programming the Trigger Layer counter for infinity (:trig:coun inf) keeps operation in the Trigger Layer. After each device action and subsequent output trigger, operation loops back to the Trigger Layer control source. A counter resets when operation loops back to a higher layer (or idle).

3.9 Programming syntax

The following information covers syntax for both common commands and SCPI commands. For information not covered here, refer to the IEEE-488.2 and SCPI standards.

Command words

Program messages are made up of one or more command words.

1. **Commands and command parameters:** Common commands and SCPI commands may or may not use a parameter. Examples:

*SAV <NRf>	Parameter (NRf) required.
*RST	No parameter used.
:INITiate:CONTinuous 	Parameter () required.
:SYSTem:PRESet	No parameter used.

Note that there must be at least one space between the command word and the parameter.

Brackets []: There are command words that are enclosed in brackets ([]). These brackets are used to denote an optional command word that does not need to be included in the program message. For example:

```
:INITiate[:IMMediate]
```

The brackets indicate that :IMMediate is implied (optional) and does not have to be used. Thus, the above command can be sent in one of two ways:

```
:INITiate or :INITiate:IMMediate
```

Notice that the optional command is used without the brackets. **Do not include the brackets when using an optional command word.**

Parameter types: Some of the more common parameter types are explained as follows:

 Boolean: Used to enable or disable an instrument operation. 0 or OFF disables the operation, and 1 or ON enables the operation. Example:

```
:CURRent:AC:RANGe:AUTO ON Enable auto-ranging.
```

AC|DC Explicit: This is an example of two explicit parameters to choose from; AC or DC. Example:

```
:CURRent:AC:COUPling AC Select AC coupling
```

<name> Name parameter: Select a parameter name from a listed group. Example:

```
<name> = NEVer
        = NEXt
        = ALWays
        = PRETrigger
```

```
:TRACe:FEED:CONTRol PRETrigger
```

- <NRf> Numeric representation format: This parameter is a number that can be expressed as an integer (e.g., 8), a real number (e.g., 23.6) or an exponent (2.3E6). Example:
- ```
:SYSTem:KEY 16 "Press" NEXT key from over the bus.
```
- <n> Numeric value: A numeric value parameter can consist of an NRf number or one of the following name parameters; DEFault, MINimum or MAXimum. When the DEFault parameter is used, the instrument is programmed to the \*RST default value. When the MINimum parameter is used, the instrument is programmed to the lowest allowable value. When the MAXimum parameter is used, the instrument is programmed to the largest allowable value. Examples:
- ```
:TRIGger:TIMer 0.1      Sets timer to 100msec.
:TRIGger:TIMer DEFault  Sets timer to 0.1sec.
:TRIGger:TIMer MINimum  Sets timer to 1msec.
:TRIGger:TIMer MAXimum  Sets timer to 999999.999sec.
```
- <list> List — Specify one or more switching channels. Examples:
- ```
:ROUte:SCAN (@1:10) Specify scan list (1 through 10).
:ROUte:SCAN (@ 2,4,6) Specify scan list (2, 4 and 6).
```

**Angle brackets <>:** Angle brackets (<>) are used to denote parameter type. Do not include the brackets in the program message. For example:

```
:SOURce:TTL2
```

The <b> indicates that a Boolean type parameter is required. Thus, to set digital input line #2 true, you must send the command with the ON or 1 parameter as follows:

```
:SOURce:TTL2 ON or :SOURce:TTL2 1
```

2. **Query commands:** This type of command requests (queries) the currently programmed status. It is identified by the question mark (?) at the end of the fundamental form of the command. Most commands have a query form. Example:

```
:TRIGger:TIMer? Queries the timer interval.
```

Most commands that require a numeric parameter (<n>) can also use the DEFault, MINimum, and MAXimum parameters for the query form. These query forms are used to determine the \*RST default value, and the upper and lower limits for the fundamental command. Examples:

```
:TRIGger:TIMer? DEFault Queries the *RST default value.
:TRIGger:TIMer? MINimum Queries the lowest allowable value.
:TRIGger:TIMer? MAXimum Queries the largest allowable value.
```

3. **Case sensitivity:** Common commands and SCPI commands are not case sensitive. You can use upper or lower case, and any case combination. Examples:

```
*RST = *rst
:SCAN? = :scan?
:SYSTem:PRESet = :system:preset
```

4. **Long-form and short-form versions:** A SCPI command word can be sent in its long-form or short-form version. The command subsystem tables in this section provide the com-

mands in the long-form version. However, the short-form version is indicated by upper case characters. Examples:

```
:SYSTem:PRESet Long-form
:SYST:PRES Short-form
:SYSTem:PRES Long and short-form combination
```

Note that each command word must be in long-form or short-form, and not something in between. For example, :SYSTe:PRESe is illegal and will generate an error. The command will not be executed.

**Short-form rules:** The following rules can be used to determine the short-form version of any SCPI command:

A. If the length of the command word is four letters or less, there is no short-form version. Example:

```
:auto = :auto
```

B. The following rules apply to command words that exceed four letters:

a. If the fourth letter of the command word is a vowel, delete it and all the letters after it. Example:

```
:immediate = :imm
```

Rule exception – The short-form version of the following command uses only the first two letters of the word:

```
:TCouple = :tc
```

b. If the fourth letter of the command word is a consonant, retain it but drop all the letters after it. Example:

```
:output = :outp
```

C. If there is a question mark (; query) or a non-optional number included in the command word, it must be included in the short-form version. Examples:

```
:delay? = :del?
```

```
:layer2 = :lay2
```

D. As previously explained, command words or characters that are enclosed in brackets ([]) are optional and need not be included in the program message.



## Program messages

A program message is made up of one or more command words sent by the computer to the instrument. Each common command is simply a three letter acronym preceded by an asterisk (\*). SCPI commands are categorized into subsystems and are structured as command paths. The following command paths are contained in the :STATus subsystem and are used to help explain how command words are structured to formulate program messages.

|                    |                       |
|--------------------|-----------------------|
| :STATus            | Path (Root)           |
| :OPERation         | Path                  |
| :PTRansition <NRf> | Command and parameter |
| :NTRansition <NRf> | Command and parameter |
| :ENABle <NRf>      | Command and parameter |
| :PRESet            | Command               |

1. **Single command messages:** There are three levels to the above command structure. The first level is made up of the root command (:STATus) and serves as a path. The second level is made up of another path (:OPERation) and a command (:PRESet). The third path is made up of three commands for the :OPERation path. The four commands in this structure can be executed by sending four separate program messages as follows:

```
:stat:oper:ptr <NRf>
:stat:oper:ntr <NRf>
:stat:oper:enab <NRf>
:stat:pres
```

In each of the above program messages, the path pointer starts at the root command (:stat) and moves down the command levels until the command is executed.

2. **Multiple command messages:** Multiple commands can be sent in the same program message as long as they are separated by semicolons (;). Example showing two commands in one program message:

```
:stat:pres; :stat:oper:enab <NRf>
```

When the above message is sent, the first command word is recognized as the root command (:stat). When the next colon is detected, the path pointer moves down to the next command level and executes the command. When the path pointer sees the colon after the semicolon (;), it resets back to the root level and starts over.

Commands that are on the same command level can be executed without having to retype the entire command path. Example:

```
:stat:oper:enab <NRf>; ptr <NRf>; ntr <NRf>
```

After the first command (:enab) is executed, the path pointer is at the third command level in the structure. Since :ptr and :ntr are also on the third level, they can be typed in without repeating the entire path name. Notice that the leading colon for :ptr and :ntr are not included in the program message. If a colon were included, the path pointer would reset to the root level and expect a root command. Since neither :ptr nor :ntr are root commands, an error would occur.

**3. Command path rules:**

- A. Each new program message must begin with the root command, unless it is optional (e.g., [:SENSe]). If the root is optional, simply treat a command word on the next level as the root.
- B. The colon (:) at the beginning of a program message is optional and need not be used. Example:  

```
:stat:pres = stat:pres
```
- C. When the path pointer detects a colon (:) it will move down to the next command level. An exception is when the path pointer detects a semicolon (;), which is used to separate commands within the program message (see next rule).
- D. When the path pointer detects a colon (:) that immediately follows a semicolon (;), it resets back to the root level.
- E. The path pointer can only move down. It cannot be moved up a level. Executing a command at a higher level requires that you start over at the root command.

4. **Using common commands and SCPI commands in same message:** Both common commands and SCPI commands can be used in the same message as long as they are separated by semicolons (;). A common command can be executed at any command level and will not affect the path pointer. Example:

```
:stat:oper:enab <NRf>; ptr <NRf>; *ESE <NRf>; ntr <NRf>
```

5. **Program Message Terminator (PMT):** Each program message must be terminated with an LF (line feed), EOI (end or identify) or an LF + EOI. The bus will hang if your computer does not provide this termination. The following example shows how a multiple command program message must be terminated:

```
:rout:open all; scan (@1:5) <PMT>
```

**6. Command execution rules:**

- A. Commands are executed in the order that they are presented in the program message.
- B. An invalid command will generate an error and, of course, not be executed.
- C. Valid commands that precede an invalid command in a multiple command program message will be executed.
- D. Valid commands that follow an invalid command in a multiple command program message will be ignored.

**Response messages**

A response message is the message sent by the instrument to the computer in response to a query command program message.

1. Sending a response message: After sending a query command, the response message is placed in the Output Queue. When the Model 2002 is then addressed to talk, the response message is sent from the Output Queue to the computer.
2. Multiple response messages: If you send more than one query command in the same program message (see Multiple command messages), the multiple response message for all the queries is sent to the computer when the Model 2002 is addressed to talk. The responses are sent in the order that the query commands were sent and are separated by semicolons (;). Items within the same query are separated by commas (.). The following example shows

the response message for a program message that contains four single item query commands:

0; 1; 1; 0

3. **Response Message Terminator (RMT):** Each response message is terminated with an LF (line feed) and EOI (end or identify). The following example shows how a multiple response message is terminated:

0; 1; 1; 0 <RMT>

## Message exchange protocol

The message exchange protocol can be summarized by the two following rules:

### **Rule 1. You must always tell the Model 2002 what to send to the computer.**

The following two steps must always be performed, in this order, to send information from the instrument to the computer:

1. Send the appropriate query command(s) in a program message.
2. Address the Model 2002 to talk.

### **Rule 2. The complete response message must be received by the computer before another program message can be sent to the Model 2002.**

### 3.10 Common commands

Common commands (summarized in Table 3-2) are device commands that are common to all devices on the bus. These commands are designated and defined by the IEEE-488.2 standard.

**Table 3-2**  
IEEE-488.2 common commands and queries

| Mnemonic   | Name                           | Description                                                                                                                   |
|------------|--------------------------------|-------------------------------------------------------------------------------------------------------------------------------|
| *CLS       | Clear status                   | Clears all event registers, and Error Queue.                                                                                  |
| *ESE <NRf> | Event Enable command           | Program the Standard Event Enable Register.                                                                                   |
| *ESE?      | Event Enable query             | Read the Standard Event Enable Register.                                                                                      |
| *ESR?      | Event status register query    | Read the Standard Event Status Register and clear it.                                                                         |
| *IDN?      | Identification query           | Returns the manufacturer, model number, serial number, and firm-ware revision levels of the unit.                             |
| *OPC       | Operation complete command     | Sets the Operation Complete bit in the Standard Event Status Register after all pending commands have been executed.          |
| *OPC?      | Operation complete query       | Places an ASCII "1" into the output queue when all pending selected device operations have been completed.                    |
| *OPT?      | Option identification query    | Returns an ID code that indicates which memory option is installed and whether or not the optional scanner card is installed. |
| *RCL <NRf> | Recall command                 | Returns the Model 2002 to the setup configuration stored in the specified memory location.                                    |
| *RST       | Reset command                  | Returns the Model 2002 to the *RST default conditions.                                                                        |
| *SAV <NRf> | Save command                   | Saves the current setup to the specified memory location.                                                                     |
| *SRE <NRf> | Service request enable command | Programs the Service Request Enable Register.                                                                                 |
| *SRE?      | Service request enable query   | Reads the Service Request Enable Register.                                                                                    |
| *STB?      | Read status byte query         | Reads the Status Byte Register.                                                                                               |
| *TRG       | Trigger command                | Sends a bus trigger to the 2002.                                                                                              |
| *TST?      | Self-test query                | Performs a checksum test on ROM and returns the result.                                                                       |
| *WAI       | Wait-to-continue command       | Wait until all previous commands are executed.                                                                                |

#### 3.10.1 \*CLS— clear status Clear status registers and error queue.

##### Description

The \*CLS command is used to clear (reset to 0) the bits of the following registers in the Model 2002:

- Standard Event Status Register
- Operation Event Register
- Error Queue
- Trigger Event Register
- Sequence Event Register
- Arm Event Status Register
- Measurement Event Register
- Questionable Event Register

This command also forces the instrument into the operation complete command idle state and operation complete query idle state.

##### Program fragment

```
PRINT #1, "output 16; *CLS" ' Clear registers and Error Queue
```

## 3.10.2

**\*ESE<NRf> — event enable** Program the Standard Event Enable Register**\*ESE? — event enable query** Read the Standard Event Enable Register**Parameters**

|           |                |
|-----------|----------------|
| <NRf> = 0 | Clear register |
| 1         | Set OPC (B0)   |
| 4         | Set QYE (B2)   |
| 8         | Set DDE (B3)   |
| 16        | Set EXE (B4)   |
| 32        | Set CME (B5)   |
| 64        | Set URQ (B6)   |
| 128       | Set PON (B7)   |
| 255       | Set all bits   |

**Description**

The \*ESE command is used to program the Standard Event Enable Register. This command is sent with the decimal equivalent of the binary value that determines the desired state (0 or 1) of the bits in the register. This register is cleared on power-up.

This register is used as a mask for the Standard Event Status Register. When a standard event is masked, the occurrence of that event will not set the Event Summary Bit (ESB) in the Status Byte Register. Conversely, when a standard event is unmasked (enabled), the occurrence of that event sets the ESB bit. For information on the Standard Event Status Register and descriptions of the standard event bits, see paragraph 3.10.3. The Status Byte Register is described in paragraph 3.7.6.

A cleared bit ("0") in the enable register prevents (masks) the ESB bit in the Status Byte Register from setting when the corresponding standard event occurs. A set bit ("1") in the enable register allows (enables) the ESB bit to set when the corresponding standard event occurs.

The Standard Event Enable Register is shown in Figure 3-14 and includes the decimal weight of each bit. The sum of the decimal weights of the bits that you wish to be set is the parameter value that is sent with the \*ESE command. For example, to set the CME and QYE bits of the Standard Event Enable Register, send the following command:

```
*ESE 36
```

|                               |           |
|-------------------------------|-----------|
| where; CME (bit B5) = Decimal | 32        |
| QYE (bit B2) = Decimal        | 4         |
| <NRf> =                       | <u>36</u> |

If a command error (CME) occurs, bit B5 of the Standard Event Status Register sets. If a query error (QYE) occurs, bit B2 of the Standard Event Status Register sets. Since both of these events are unmasked (enabled), the occurrence of any one of them causes the ESB bit in the Status Byte Register to set.

The Standard Event Status Event Register can be read by using the \*ESE? query command.

**Program fragment**

```
PRINT #1, "output 16; *ese 24; *ese?" ' Set bits B3 and B4, and query
PRINT #1, "enter 16" ' Get response from 2002
```

|                   |                          |                         |                         |                         |                        |                        |    |                        |
|-------------------|--------------------------|-------------------------|-------------------------|-------------------------|------------------------|------------------------|----|------------------------|
| Bit Position      | B7                       | B6                      | B5                      | B4                      | B3                     | B2                     | B1 | B0                     |
| Event             | PON                      | URQ                     | CME                     | EXE                     | DDE                    | QYE                    | —  | OPC                    |
| Decimal Weighting | 128<br>(2 <sup>7</sup> ) | 64<br>(2 <sup>6</sup> ) | 32<br>(2 <sup>5</sup> ) | 16<br>(2 <sup>4</sup> ) | 8<br>(2 <sup>3</sup> ) | 4<br>(2 <sup>2</sup> ) | —  | 1<br>(2 <sup>0</sup> ) |
| Value             | 0/1                      | 0/1                     | 0/1                     | 0/1                     | 0/1                    | 0/1                    | —  | 0/1                    |

Note : Bits B8 through B15 are not shown since they are not used.

Value : 1 = Enable Standard Event  
0 = Disable (Mask) Standard Event

Events : PON = Power On  
URQ = User Request  
CME = Command Error  
EXE = Execution Error  
DDE = Device-dependent Error  
QYE = Query Error  
OPC = Operation Complete

**Figure 3-14**  
*Standard Event Enable Register*

### 3.10.3 \*ESR?— event status register query Read the Standard Event Status Register and clear it.

#### Description

This command is used to acquire the value (in decimal) of the Standard Event Status Register (see Figure 3-15). The binary equivalent of the returned decimal value determines which bits in the register are set. This register is cleared on power-up or when \*CLS is sent.

A set bit in this register indicates that a particular event has occurred. For example, for an acquired decimal value of 48, the binary equivalent is 00110000. For this binary value, bits B4 and B5 of the Standard Event Status Register are set. These set bits indicate that a device-dependent error and command error have occurred.

The bits of the Standard Event Status Register are described as follows:

**Bit B0, Operation Complete (OPC)** — Set bit indicates that all pending selected device operations are completed and the Model 2002 is ready to accept new commands. This bit only sets in response to the \*OPC? query command (see paragraph 3.10.6).

**Bit B1** — Not Used.

**Bit B2, Query Error (QYE)** — Set bit indicates that you attempted to read data from an empty Output Queue.

**Bit B3, Device-dependent Error (DDE)** — Set bit indicates that an instrument operation did not execute properly due to some internal condition.

**Bit B4, Execution Error (EXE)** — Set bit indicates that the Model 2002 detected an error while trying to execute a command.

**Bit B5, Command Error (CME)** — Set bit indicates that a command error has occurred. Command errors include:

1. IEEE-488.2 syntax error: Model 2002 received a message that does not follow the defined syntax of the IEEE-488.2 standard.
2. Semantic error: Model 2002 received a command that was misspelled, or received an optional IEEE-488.2 command that is not implemented.
3. The instrument received a Group Execute Trigger (GET) inside a program message.

**Bit B6, User Request (URQ)** — Set bit indicates that the LOCAL key on the Model 2002 front panel was pressed.

**Bit B7, Power On (PON)** — Set bit indicates that the Model 2002 has been turned off and turned back on since the last time this register has been read.

**Program fragment**

```
PRINT #1, "output 16; *esr?" ' Query register
PRINT #1, "enter 16" ' Get response message from 2002
```

|                   |                          |                         |                         |                         |                        |                        |    |                        |
|-------------------|--------------------------|-------------------------|-------------------------|-------------------------|------------------------|------------------------|----|------------------------|
| Bit Position      | B7                       | B6                      | B5                      | B4                      | B3                     | B2                     | B1 | B0                     |
| Event             | PON                      | URQ                     | CME                     | EXE                     | DDE                    | QYE                    | —  | OPC                    |
| Decimal Weighting | 128<br>(2 <sup>7</sup> ) | 64<br>(2 <sup>6</sup> ) | 32<br>(2 <sup>5</sup> ) | 16<br>(2 <sup>4</sup> ) | 8<br>(2 <sup>3</sup> ) | 4<br>(2 <sup>2</sup> ) | —  | 1<br>(2 <sup>0</sup> ) |
| Value             | 0/1                      | 0/1                     | 0/1                     | 0/1                     | 0/1                    | 0/1                    | —  | 0/1                    |

Note : Bits B8 through B15 are not shown since they are not used.

Value : 1 = Event Bit Set  
 0 = Event Bit Cleared

Events : PON = Power On  
 URQ = User Request  
 CME = Command Error  
 EXE = Execution Error  
 DDE = Device-dependent Error  
 QYE = Query Error  
 OPC = Operation Complete

**Figure 3-15**  
*Standard Event Status Register*

**3.10.4**

**\*IDN?— identification query** Read the identification code

**Description**

The identification code includes the manufacturer, model number, serial number, and firmware revision levels, and is sent in the following format:

KEITHLEY INSTRUMENTS INC., MODEL 2002, xxxxxxx, yyyy/zzzz

where; xxxxxxx is the serial number  
 yyyy/zzzz is the firmware revision levels of the digital board ROM and display board ROM.

**Program fragment**

```
PRINT #1, "output 16; *idn?" ' Query ID code
PRINT #1, "enter 16" ' Get response message from 2002
```

## 3.10.5

**\*OPC — operation complete** Set the Operation Complete bit in the Standard Event Status Register after all pending commands are complete.

**Description**

On power-up, or when \*CLS or \*RST is executed, the Model 2002 goes into the Operation Complete Command Idle State (OCIS). In this state there are no pending overlapped commands. There are three overlapped commands used by the Model 2002:

```
:INITiate
:INITiate:CONTinuous ON
*TRG
```

When the \*OPC command is sent, the Model 2002 exits from OCIS and enters the Operation Complete Command Active State (OCAS). In OCAS, the instrument continuously monitors the No-Operation-Pending flag. After the last pending overlapped command is complete (No-Operation-Pending flag set to true), the Operation Complete (OPC) bit in the Standard Event Status Register sets, and the instrument goes back into OCIS.

Note that the instrument always goes into OCAS when \*OPC is executed. If there are no pending command operations (e.g. trigger model in idle state), the Model 2002 immediately sets the OPC bit and returns to OCIS.

When used with the :INITiate or :INITiate:CONTinuous ON command, the OPC bit of the Standard Event Status Register will not set until the Model 2002 goes back into the idle state. The initiate operations are not considered finished until the instrument goes into the idle state.

When used with the \*TRG command, the OPC bit will not set until the operations associated with the \*TRG command (and the initiate command) are finished. The \*TRG command is considered to be finished when the Device Action completes or when operation stops at a control source to wait for an event (see Trigger Model in paragraph 3.8).

In order to use \*OPC exclusively with the \*TRG command, you will have to first force the completion of the initiate command so that only the \*TRG command is pending. To do this, send the :ABORt command to place the instrument in idle, which (by definition) completes the initiate command. Since continuous initiation is on, operation continues on into the Trigger Model. After sending the \*TRG command, the OPC bit sets when the \*TRG command is finished.

**Program fragment**

```
GOSUB ReadRegister ' Clear register by reading it
PRINT #1, "output 16; :init:cont off; :abort" ' Place 2002 in idle
PRINT #1, "output 16; :init; *opc" ' Start measurements and send *OPC
SLEEP 2 ' Wait two seconds
GOSUB ReadRegister ' Read register to show that OPC is not set
PRINT #1, "output 16; :abort" ' Place 2002 back in idle
GOSUB ReadRegister ' Read register to show that OPC is now set
END

ReadRegister:
PRINT #1, "output 16; *esr?" ' Query Standard Event Status Register
PRINT #1, "enter 16" ' Get response message from 2002
LINE INPUT #2, a$ ' Read decimal value of register
PRINT a$ ' Display decimal value of register
RETURN
```



### 3.10.6 \*OPC?— operation complete query Place a "1" in the Output Queue after all pending operations are completed

#### Description

On power-up, or when \*CLS or \*RST is executed, the Model 2002 goes into the Operation Complete Command Query Idle State (OQIS). In this state there are no pending overlapped commands. There are three overlapped commands used by the Model 2002:

```
:INITiate
:INITiate:CONTInuous ON
*TRG
```

When the \*OPC? command is sent, the Model 2002 exits from OQIS and enters the Operation Complete Command Active State (OQAS). In OQAS, the instrument continuously monitors the No-Operation-Pending flag. After the last pending overlapped command is completed (No-Operation-Pending flag set to true), an ASCII character "1" is placed into the Output Queue, the Message Available (MAV) bit in the Status Byte sets, and the instrument goes back into OQIS. Addressing the Model 2002 to talk sends the ASCII "1" to the computer.

Note that the instrument always goes into OQAS when \*OPC? is executed. If there are no pending command operations (e.g. trigger model in idle state), the Model 2002 immediately places an ASCII "1" in the Output Queue, sets the MAV bit and returns to OQIS.

When used with the :INITiate or :INITiate:CONTInuous ON command, an ASCII "1" will not be sent to the Output Queue and the MAV bit will not set until the Model 2002 goes back into the idle state. The initiate operations are not considered finished until the instrument goes into the idle state.

When used with the \*TRG command, an ASCII "1" will not be placed into the Output Queue and the MAV bit will not set until the operations associated with the \*TRG command (and the initiate command) are finished. The \*TRG command is considered to be finished when the Device Action completes or when operation stops at a control source to wait for an event (see Trigger Model in paragraph 3.8).

In order to use \*OPC? exclusively with the \*TRG command you will have to first force the completion of the initiate command so that only the \*TRG command is pending. To do this, send the :ABORt command to place the instrument in idle, which (by definition) completes the initiate command. Since continuous initiation is on, operation continues on into the Trigger Model. After sending the \*TRG command, an ASCII "1" is placed in the Output Queue and the MAV bit sets when the \*TRG command is finished.

After \*OPC? is executed, additional commands cannot be sent to the Model 2002 until the pending overlapped commands have finished. For example, :INITiate:CONTInuous ON followed by \*OPC? locks up the instrument and requires a device clear (DCL or SDC) before it will accept any more commands.

#### NOTE

See \*OPC, \*TRG and \*WAI for more information.

#### Program fragment

```
PRINT #1, "output 16; :syst:pres" ' Select defaults
PRINT #1, "output 16; :init:cont off; :abort" ' Place 2002 in idle
PRINT #1, "output 16; :am:coun 1" ' Program for 5 measurements and
 stop (idle)

PRINT #1, "output 16; :am:lay2: coun 1"
PRINT #1, "output 16; :trig: coun 5; sour tim"
PRINT #1, "outut 16; :init; *opc?" ' Start measurements and send *opc?
PRINT #1, "enter 16" ' Get response when 2002 goes into idle
LINE INPUT #2, a$ ' Read contents of Output Queue
PRINT a$ ' Display the ASCII "1"
```

### 3.10.7 \*OPT?— option identification query Determine which options are installed in the Model 2002.

#### Description

The response message is made up of two comma separated fields. The first field indicates the presence or absence of extra memory.

0            No extra memory (8k bytes volatile)  
 MEM1       Memory Option 1 (32k bytes non-volatile)  
 MEM2       Memory Option 2 (128k bytes non-volatile)

The second field indicates the presence or absence of the Model 2001-SCAN scanner card.

0            No scanner card installed  
 2001-SCAN   Model 2001-SCAN installed

Example: The following response message indicates that Memory Option 2 and the scanner card are installed:

MEM2, 2001-SCAN

#### Program fragment

```
PRINT #1, "output 16; *opt?" ' Query installed options
PRINT #1, "enter 16" ' Send response message to 2002
```

### 3.10.8 \*RCL—recall Return to a setup stored in memory.

#### Parameters

| No extended memory | Model 2002-MEM1 installed | Model 2002-MEM2 installed |
|--------------------|---------------------------|---------------------------|
| <NRf> = 0          | <NRf> = 0 to 4            | <NRf> = 0 to 9            |

#### Description

This command is used to return the Model 2002 to a setup configuration stored at a memory location. The \*SAV command is used to store a setup configuration at a memory location (see paragraph 3.10.10).

If the Model 2002 does not have any extended memory installed, only one setup configuration can be saved and recalled. In this situation, memory location “0” is the only valid parameter for the \*RCL command. If the Model 2002-MEM1 memory element is installed, up to five setup configurations can be saved and recalled. In this situation, memory locations “0” through “4” are valid parameters. If the Model 2002-MEM2 memory element is installed, up to 10 setup configurations can be saved and recalled. Memory locations “0” through “9” are then valid parameters.

The Model 2002 is shipped from the factory with :SYSTEM:PRESet defaults loaded into the available setup memories. If a recall error occurs, the setup memories default to the :SYSTEM:PRESet values.

#### Program fragment

```
PRINT #1, "output 16; *rcl 0" ' Recall setup stored at memory location 0
```

**3.10.9 \*RST — reset** Reset the Model 2002**Description**

When the \*RST command is sent, the Model 2002 performs the following operations:

1. Returns the Model 2002 to the \*RST default conditions (see SCPI tables).
2. Cancels all pending commands.
3. Cancels response to any previously received \*OPC and \*OPC? commands.

**Program fragment**

```
PRINT #1, "output 16; *rst" ' Return 2002 to *rst defaults
```

**3.10.10 \*SAV — save** Save the current setup in memory**Parameters**

| No extended<br>memory | Model 2002-MEM1<br>installed | Model 2002-MEM2<br>installed |
|-----------------------|------------------------------|------------------------------|
| <NRf> = 0             | <NRf> = 0 to 4               | <NRf> = 0 to 9               |

**Description**

The \*SAV command is used to save the current instrument setup configuration in memory for later recall. Any control affected by \*RST can be saved by the \*SAV command. The \*RCL command is used to restore the instrument to a saved setup configuration.

If the Model 2002 does not have any extended memory installed, only one setup configuration can be saved and recalled. In this situation, memory location “0” is the only valid parameter for the \*SAV command. If the Model 2002-MEM1 memory element is installed, up to five setup configurations can be saved and recalled. In this situation, memory locations “0” through “4” are valid parameters. If the Model 2002-MEM2 memory element is installed, up to 10 setup configurations can be saved and recalled. Memory locations “0” through “9” are then valid parameters.

**Program fragment**

```
PRINT #1, "output 16; *SAV 0" ' Store setup at memory location 0.
```

**3.10.11 \*SRE <NRf> — service request enable** Program the Service Request Enable Register

**\*SRE? — service request enable query** Read the Service Request Enable Register

**Parameters**

|           |                        |
|-----------|------------------------|
| <NRf> = 0 | Clears enable register |
| = 1       | Set MSB bit (Bit 0)    |
| = 4       | Set EAV bit (Bit 2)    |
| = 8       | Set QSB bit (Bit 3)    |
| = 16      | Set MAV bit (Bit 4)    |
| = 32      | Set ESB bit (Bit 5)    |
| = 128     | Set OSB bit (Bit 7)    |
| = 255     | Sets all bits          |

**Description**

The \*SRE command is used to program the Service Request Enable Register. This command is sent with the decimal equivalent of the binary value that determines the desired state (0 or 1) of each bit in the register. This register is cleared on power-up.

This enable register is used along with the Status Byte Register to generate service requests (SRQ). With a bit in the Service Request Enable Register set, an SRQ occurs when the corresponding bit in the Status Byte Register is set by an appropriate event. For details on register structure, refer to paragraph 3.7.

The Service Request Enable Register is shown in Figure 3-16. Notice that the decimal weight of each bit is included in the illustration. The sum of the decimal weights of the bits that you wish to set is the value that is sent with the \*SRE command. For example, to set the ESB and MAV bits of the Service Request Enable Register, send the following command:

\*SSE 34

where; ESB (bit B5) = Decimal 32  
 MAV (bit B4) = Decimal 16  
 <Nrf> = 48

The contents of the Service Request Enable Register can be read using the \*SRE? query command.

### Program fragment

```
PRINT #1, "output 16; *sre 32; *sre?" ' Unmask ESB bit and query register
PRINT #1, "enter 16" ' Send response message to 2002
```

| Bit Position      | B7                       | B6 | B5                      | B4                      | B3                     | B2                     | B1 | B0                     |
|-------------------|--------------------------|----|-------------------------|-------------------------|------------------------|------------------------|----|------------------------|
| Event             | OSB                      | —  | ESB                     | MAV                     | QSB                    | EAV                    | —  | MSB                    |
| Decimal Weighting | 128<br>(2 <sup>7</sup> ) | —  | 32<br>(2 <sup>5</sup> ) | 16<br>(2 <sup>4</sup> ) | 8<br>(2 <sup>3</sup> ) | 4<br>(2 <sup>2</sup> ) | —  | 1<br>(2 <sup>0</sup> ) |
| Value             | 0/1                      | —  | 0/1                     | 0/1                     | 0/1                    | 0/1                    | —  | 0/1                    |

Value : 1 = Enable Service Request Event  
 0 = Disable (Mask) Service Request Event

Events : OSB = Operation Summary Bit  
 ESB = Event Summary Bit  
 MAV = Message Available  
 QSB = Questionable Summary Bit  
 EAV = Error Available  
 MSB = Measurement Summary Bit

**Figure 3-16**  
*Service Request Enable Register*

**3.10.12 \*STB?— status byte query** Read the Status Byte Register**Description**

The \*STB? query command is used to acquire the value (in decimal) of the Status Byte Register. The Status Byte Register is shown in Figure 3-17. The binary equivalent of the decimal value determines which bits in the register are set.

All bits, except Bit 6, in this register are set by other event registers and queues. Bit 6 sets when one or more enabled conditions occur.

The \*STB? query command does not clear the status byte register. This register can only be cleared by clearing the related registers and queues. Register and queue structure are explained in paragraph 3.7.

For example, for an acquired decimal value of 48, the binary equivalent is 00110000. This binary value indicates that Bits 4 and 5 of the Status Byte Register are set.

The bits of the Status Byte Register are described as follows:

**Bit 0, Measurement Status (MSB)** — Set bit indicates that a measurement event has occurred. The event can be identified by reading the Measurement Event Status Register using the :STATus:MEASurement? command (see paragraph 3.20 for details).

**Bit 1** — Not used.

**Bit 2, Error Available (EAV)** — Set bit indicates that an error or status message is present in the Error Queue. The message can be read using one of the following SCPI commands:

```
:SYSTem:ERRor?
:STATus:QUEue?
```

See paragraphs 3.21 and 3.20 for details.

**Bit 3, Questionable Summary Bit (QSB)** — Set bit indicates that a calibration error has occurred.

**Bit 4, Message Available (MAV)** — Set bit indicates that a message is present in the Output Queue. The message is sent to the computer when the Model 2002 is addressed to talk.

**Bit 5, Event Summary Bit (ESB)** — Set bit indicates that an enabled standard event has occurred. The event can be identified by reading the Standard Event Status Register using the \*ESE? query command (see paragraph 3.10.2).

**Bit 6, Master Summary Status (MSS) / Request Service (RQS)** — Set bit indicates that one or more enabled Status Byte conditions have occurred. The MSS bit can be read using the STB? query command, or the occurrence of a service request (RQS bit set) can be detected by performing a Serial Poll.

**Bit 7, Operation Summary Bit (OSB)** — Set bit indicates that an enabled operation event has occurred. The event can be identified by reading the Operation Event Status Register using the :STATus:OPERation? query command (see paragraph 3.20 for details).

**Program fragment**

```
PRINT #1, "output 16; *stb?" ' Query Status Byte Register
PRINT #1, "enter 16" ' Send response message to 2002
```

|                   |                          |                         |                         |                         |                        |                        |    |                        |
|-------------------|--------------------------|-------------------------|-------------------------|-------------------------|------------------------|------------------------|----|------------------------|
| Bit Position      | B7                       | B6                      | B5                      | B4                      | B3                     | B2                     | B1 | B0                     |
| Event             | OSB                      | MSS,<br>RQS             | ESB                     | MAV                     | QSB                    | EAV                    | —  | MSB                    |
| Decimal Weighting | 128<br>(2 <sup>7</sup> ) | 64<br>(2 <sup>6</sup> ) | 32<br>(2 <sup>5</sup> ) | 16<br>(2 <sup>4</sup> ) | 8<br>(2 <sup>3</sup> ) | 4<br>(2 <sup>2</sup> ) | —  | 1<br>(2 <sup>0</sup> ) |
| Value             | 0/1                      | 0/1                     | 0/1                     | 0/1                     | 0/1                    | 0/1                    | —  | 0/1                    |

Value : 1 = Event Bit Set  
0 = Event Bit Cleared

Events : OSB = Operation Summary Bit  
MSS = Master Summary Status  
RQS = Request Service  
ESB = Event Summary Bit  
MAV = Message Available  
QSB = Questionable Summary Bit  
EAV = Error Available  
MSB = Measurement Summary Bit

**Figure 3-17**  
*Status Byte Register*

### 3.10.13 \*TRG — trigger Send a GPIB trigger to the Model 2002.

#### Description

The \*TRG command is used to issue a GPIB trigger to the Model 2002. It has the same effect as a group execute trigger (GET).

The \*TRG command is used as an arm, scan and/or measure event to control operation. The Model 2002 reacts to this trigger if GPIB is the programmed control source. The control source is programmed from the :TRIGger subsystem (see paragraph 3.22).

\*TRG can also be used as the pre-trigger for buffer operation.

#### Program fragment

```
PRINT #1, "output 16; *trg" ' Trigger 2002
```

### 3.10.14 \*TST? — self-test query Run the self-test and acquire the result.

#### Description

This query command is used to perform a checksum test on ROM and places the coded result (0 or 1) in the Output Queue. When the Model 2002 is addressed to talk, the coded result is sent from the Output Queue to the computer.

A returned value of zero (0) indicates that the test passed, and a value of one (1) indicates that the test has failed.

#### Program fragment

```
PRINT #1, "output 16; *tst?" ' Run test and query result
PRINT #1, "enter 16" ' Send response message to 2002
```

### 3.10.15 **\*WAI — wait-to-continue** Prevent the execution of commands until all previous commands are completed.

#### Description

There are two types of device commands; Sequential commands and Overlapped commands. A Sequential command is a command whose operations are allowed to finish before the next command is executed. An Overlapped command is a command that allows the execution of subsequent commands while device operations of the Overlapped command are still in progress. The \*WAI command is used to hold off the execution of subsequent commands until the device operations of all previous Overlapped commands are finished. The \*WAI command is not needed for Sequential commands.

There are three Overlapped commands in the Model 2002; :INITiate, :INITiate:CONTinuous ON and \*TRG.

#### NOTE

See \*OPC, \*OPC? and \*TRG for more information.

The :INITiate commands take the Model 2002 out of the idle state. The device operations of :INITiate are not considered complete until the Model 2002 goes back into idle. By sending the \*WAI command after the :INITiate command, all subsequent commands will not execute until the Model 2002 goes back into idle.

The \*TRG command issues a bus trigger which could be used to provide the arm, scan and measure events for the Trigger Model. By sending the \*WAI command after the \*TRG command, subsequent commands will not be executed until the pointer for the Trigger Model has finished moving in response to \*TRG and has settled at its next state.

#### Program fragment

```
PRINT #1, "output 16; :syst:pres" ' Select defaults
PRINT #1, "output 16; :init:cont off; :abort" ' Place 2002 in idle
PRINT #1, "output 16; :arm:coun 1" ' Program for 30 measurements and
 ' then stop (idle)

PRINT #1, "output 16; :arm:lay2:coun 1"
PRINT #1, "output 16; :trig:coun 30; sour tim"
PRINT #1, "output 16; :init; *wai" ' Start measurements and send
 ' *wai

PRINT #1, "output 16; :data?" ' Query a reading
PRINT #1, "enter 16" ' Get reading after 2002 goes
 ' into idle

LINE INPUT #2, a$ ' Read the reading
PRINT a$ ' Display the reading
```

### 3.11 Signal oriented measurement commands

The signal oriented command group is used to acquire readings using a set of high-level instructions to control the measurement process. These commands are summarized in Table 3-3.

**Table 3-3**  
Signal oriented measurement command summary

| Command                | Description                                                                  |
|------------------------|------------------------------------------------------------------------------|
| :FETCh?                | Requests the latest reading.                                                 |
| :CONFigure:<function>  | Places the 2002 in a “one-shot” measurement mode for the specified function. |
| :READ?                 | Performs an :ABORt, :INITiate, and a :FETCh?.                                |
| :MEASure[:<function>]? | Performs an :ABORt, :CONFigure:<function>, and a :READ?.                     |

#### :FETCh?

##### Description

This query command is used to request the latest post-processed reading. After sending this command and addressing the Model 2002 to talk, the reading will be sent to the computer. This command does not affect the instrument setup.

This command does not trigger a measurement. It simply requests the last available reading. Note that this command can repeatedly return the same reading. In the absence of a new reading, this command will simply return the old reading. If your application requires “fresh” readings, use the :DATA:FRESH? command (see SENSE Subsystem).

This command is automatically asserted when the :READ? or :MEASure? command is sent.

##### Program fragment

```
PRINT #1, "output 16; :syst:pres" ' Select system preset defaults
PRINT #1, "output 16; :fetch?" ' Request the latest reading
PRINT #1, "enter 16" ' Get response message from 2002
```

#### :CONFigure:<function>

```
where: <function> = VOLTage:DC DCV function
 = CURRent:DC DCI function
 = VOLTage:AC ACV function
 = CURRent:AC ACI function
 = RESistance Ω2 function
 = FRESistance Ω4 function
 = FREQuency FREQ function
 = TEMPerature TEMP function
```

##### Query

```
:CONFigure? Query the selected function
Short-form format: :conf?
Response message: CURR:DC, VOLT:AC, CURR:AC, VOLT:DC, RES, FRES, FREQ or
 TEMP
```



**Description**

This command is used to configure the instrument for subsequent measurements on the specified function. Basically, this command places the instrument in a “one-shot” measurement mode. The :READ? command can then be used to trigger a measurement and acquire a reading (see :READ?).

When this command is sent, the Model 2002 will be configured as follows:

- The function specified by this command is selected.
- All controls related to the selected function are defaulted to the \*RST values.
- Continuous initiation is disabled (:INITiate:CONTInuous OFF).
- The control sources in all three layers of the Trigger Model are set to Immediate.
- The count values in all three layers of the Trigger Model are set to one (1).
- The delay in all three layers of the Trigger Model are set to zero (0).
- The Model 2002 is placed in the idle state.
- All math calculations are disabled.
- Buffer operation is disabled. A storage operation currently in process will be aborted.
- Autozero controls are set to the \*RST default values.
- The acquisition method is set to normal.
- All operations associated with switching cards (scanning) are disabled.

This command is automatically asserted when the :MEASure? command is sent.

**Program fragment**

```
PRINT #1, "output 16; :conf:volt:dc" ' Perform :CONFigure operations.
```

**:READ?****Description**

This command is typically used to acquire a post-processed reading after the instrument has been configured by the :CONFigure command. The :CONFigure command places the instrument in a “one-shot” measurement mode. Every time the :READ? command is then sent, a measurement conversion will occur and the reading will be acquired.

When this command is sent, the following commands will be executed in the order that they are presented:

```
:ABORt
:INITiate
:FETCh?
```

When :ABORt is executed, the instrument will go into the idle state if continuous initiation is disabled. Otherwise, operation will re-start at the beginning of the Trigger Model.

If the instrument is in the idle state, :INITiate will take the instrument out of the idle state. If continuous initiation is enabled, (:INITiate:CONTInuous ON), then the :INITiate command will generate an error and ignore the command.

The :FETCh? for details. Note that an “Init ignored” error will not cancel the execution of the :FETCh? command.

**Program fragment**

```
PRINT #1, "output 16; :conf:volt:dc" ' Select "one-shot" DCV function
PRINT #1, "output 16; :read?" ' Perform :READ? operations
PRINT #1, "enter 16" ' Get response message from 2002
```

**:MEASure[:<function>]?**

|                                |                     |
|--------------------------------|---------------------|
| where: <function> = VOLTage:DC | DCV function        |
| = CURRent:DC                   | DCI function        |
| = VOLTage:AC                   | ACV function        |
| = CURRent:AC                   | ACI function        |
| = RESistance                   | $\Omega$ 2 function |
| = FRESistance                  | $\Omega$ 4 function |
| = FREQuency                    | FREQ function       |
| = TEMPerature                  | TEMP function       |

**Description**

This command combines all of the other signal oriented measurement commands to perform a “one-shot” measurement and acquire the reading.

When this command is sent, the following commands are executed in the order that they are presented.

```
:ABORt:CONFiGure:<function>:READ?
```

When :ABORt is executed, the instrument will go into the idle state if continuous initiation is disabled. Otherwise, operation will re-start at the beginning of the Trigger Model.

When :CONFiGure is executed, the instrument will go into a “one-shot” measurement mode. See :CONFiGure for details.

When :READ? is executed, its operations will then be performed. In general, another :ABORt will be performed, than an :INITiate and finally a FETCh? to acquire the reading. See :READ? for details.

**Program fragment**

```
PRINT #1, "output 16; :meas?" ' Perform :MEASure? operations
PRINT #1, "enter 16" ' Get response message from 2002
```



## SCPI command subsystems

SCPI commands are categorized into subsystems and are summarized in Tables 3-4 through 3-16. Following the tables, the subsystems are covered in the following alphabetical order:

- 3.12 Calculate subsystems** — Use :CALCulate1 to configure and control the math operations. Use :CALCulate2 to manipulate readings stored in the buffer, and use :CALCulate3 to configure and control the limit tests.
- 3.13 :DISPlay subsystem** — Use to control display readings and messages.
- 3.14 :FORMat subsystem** — Use to select the data format for transferring instrument readings over the bus.
- 3.15 :INPut subsystem** — Use the Model 1801 Preamp.
- 3.16 :OUTPut subsystem** — Use to select the polarity for the digital output lines.
- 3.17 :ROUte subsystem** — Use to control switching.
- 3.18 Sense subsystems** — Use :SENSe1 to configure and control the measurement functions. Use :SENSe2 to read the digital input port.
- 3.19 :SOURce subsystem** — Use to control the digital output port.
- 3.20 :STATus subsystem** — Use to configure and control the status registers.
- 3.21 :SYSTem subsystem** — Commands not covered by the other subsystems.
- 3.22 :TRACe subsystem** — Use to control the reading buffer.
- 3.23 Trigger subsystem** — Use to configure the Trigger Model.
- 3.24 :UNIT subsystem** — Use to select measurement units.



Table 3-4 (Continued)

CALCulate command summary

| Command       | Description                                                               | Default parameter | SCPI | Ref.   |
|---------------|---------------------------------------------------------------------------|-------------------|------|--------|
| :CALCulate3   | Subsystem to control CALC 3 (limit tests):                                |                   | √    | 3.12.3 |
| :LIMit[1]     | Path to control LIMIT 1 test:                                             |                   | √    |        |
| :UPPer        | Path to configure upper limit:                                            |                   | √    |        |
| [:DATA] <n>   | Set upper limit (-9.999999e35 to +9.999999e35).                           | 1                 | √    |        |
| [:DATA]?      | Query upper limit.                                                        |                   | √    |        |
| :SOURce <NRf> | Specify digital output (0 to 15).                                         | 0                 | √    |        |
| :SOURce?      | Query source.                                                             |                   | √    |        |
| :LOWer        | Path to configure lower limit:                                            |                   | √    |        |
| [:DATA] <n>   | Set lower limit (-9.999999e35 to +9.999999e35).                           | -1                | √    |        |
| [:DATA]?      | Query lower limit.                                                        |                   | √    |        |
| :SOURce <NRf> | Specify digital output (0 to 15).                                         | 0                 | √    |        |
| :SOURce?      | Query source.                                                             |                   | √    |        |
| :STATe <b>    | Enable or disable limit test.                                             | OFF               | √    |        |
| :STATe?       | Query state of limit test.                                                |                   | √    |        |
| :FAIL?        | Query test result (1 = pass, 0 = fail).                                   |                   | √    |        |
| :CLEAR        | Path to clear failed test:                                                |                   | √    |        |
| [:IMMEDIATE]  | Clear failed test indication.                                             |                   | √    |        |
| :AUTO <b>     | Enable or disable auto clear.                                             | ON                | √    |        |
| :AUTO?        | Query auto clear.                                                         |                   | √    |        |
| :LIMit2       | Path to control LIMIT 2 test:                                             |                   | √    |        |
| :UPPer        | Path to configure upper limit:                                            |                   | √    |        |
| [:DATA] <n>   | Set upper limit (-9.999999e35 to +9.999999e35).                           | 1                 | √    |        |
| [:DATA]?      | Query upper limit.                                                        |                   | √    |        |
| :SOURce <NRf> | Set digital output (0 to 15).                                             | 0                 | √    |        |
| :SOURce?      | Query source (digital output value).                                      |                   | √    |        |
| :LOWer        | Path to configure lower limit:                                            |                   | √    |        |
| [:DATA] <n>   | Specify lower limit (-9.999999e35 to +9.999999e35).                       | -1                | √    |        |
| [:DATA]?      | Query lower limit.                                                        |                   | √    |        |
| :SOURce <NRf> | Specify digital output (0 to 15).                                         | 0                 | √    |        |
| :SOURce?      | Query source (digital output value).                                      |                   | √    |        |
| :STATe <b>    | Enable or disable limit test.                                             | OFF               | √    |        |
| :STATe?       | Query state of limit test.                                                |                   | √    |        |
| :FAIL?        | Query test result (1 = pass, 0 = fail).                                   |                   | √    |        |
| :CLEAR        | Path to clear failed test:                                                |                   | √    |        |
| [:IMMEDIATE]  | Clear failed test indication.                                             |                   | √    |        |
| :AUTO <b>     | Enable or disable auto clear.                                             | ON                | √    |        |
| :AUTO?        | Query auto clear.                                                         |                   | √    |        |
| :PASS         | Path to define “pass” digital output pattern.                             |                   |      |        |
| :SOURce <NRf> | Specify digital output (0 to 15).                                         | 0                 | √    |        |
| :CLIMits      | Command path for composite limits:                                        |                   | √    |        |
| :FAIL?        | Query composite result of LIMIT 1 and LIMIT 2 tests (1 = pass, 0 = fail). |                   | √    |        |
| :BSTRobe      | Path to control limit binning strobe:                                     |                   |      |        |
| :STATe <b>    | Enable or disable strobe.                                                 | OFF               |      |        |
| :STATe?       | Query state of binning strobe.                                            |                   |      |        |
| :IMMEDIATE    | Re-perform limit tests.                                                   |                   | √    |        |

**Table 3-5***DISPlay command summary*

| Command                                                                                     | Description                                                                                                                                                                                                                                                           | Default parameter                | SCPI                       |
|---------------------------------------------------------------------------------------------|-----------------------------------------------------------------------------------------------------------------------------------------------------------------------------------------------------------------------------------------------------------------------|----------------------------------|----------------------------|
| :DISPlay<br>[:WINDow[1]]<br>:TEXT<br>:DATA <a><br>:DATA?<br>:STATe <b><br>:STATe?<br>:DATA? | Path to locate message to top display.<br>Path to control user text messages.<br>Define ASCII message "a" (up to 20 characters).<br>Query text message.<br>Enable or disable message mode.<br>Query text message state.<br>Read data on top portion of display.       | (Note 1)<br><br><br><br>(Note 2) | √<br>√<br>√<br>√<br>√<br>√ |
| :WINDow2<br>:TEXT<br>:DATA <a><br>:DATA?<br>:STATe <b><br>:STATe?<br>:DATA?                 | Path to locate message to bottom display.<br>Path to control user text messages.<br>Define ASCII message "a" (up to 32 characters).<br>Query text message.<br>Enable or disable message mode.<br>Query text message state.<br>Read data on bottom portion of display. | (Note 1)<br><br><br><br>(Note 2) | √<br>√<br>√<br>√<br>√<br>√ |
| :CNDisplay<br>:SMESsage <b><br>:SMESsage?<br>:ENABle <b><br>:ENABle?                        | Clear NEXT (or PREV) display messages and cancel associated operations.<br>Enable or disable status message mode.<br>Query status message state.<br>Enable or disable the front panel display.<br>Query state of the display.                                         | OFF<br><br><br>(Note 3)          | <br><br><br>√<br>√         |

## Notes:

1. \*RST and :SYSTEM:PRESet has no effect on a user defined message. Cycling power cancels all user defined messages.
2. \*RST and :SYSTEM:PRESet has no effect on the state of the message mode. Cycling power disables (OFF) the message mode.
3. \*RST and :SYSTEM:PRESet has no effect on the display circuitry. Cycling power enables (ON) the display circuitry.

**Table 3-6***FORMat command summary*

| Command                                                                                                                                       | Description                                                                                                                                                                                                                                                                                                                  | Default parameter                                    | SCPI                         |
|-----------------------------------------------------------------------------------------------------------------------------------------------|------------------------------------------------------------------------------------------------------------------------------------------------------------------------------------------------------------------------------------------------------------------------------------------------------------------------------|------------------------------------------------------|------------------------------|
| :FORMat<br>[:DATA] <type>[,<length>]<br>[:DATA]?<br>:ELEMents <item list><br><br>:ELEMents?<br>:BORDER <name><br>:BORDER?<br>:EXponent <name> | Select data format: (ASCii, REAL,32, REAL,64, SREal or DREal).<br>Query data format.<br>Specify data elements: (READING, CHANnel, RNUMBER, UNITS, TIMEstamp and STATus).<br>Query data elements.<br>Select binary byte order: (NORMAL or SWAPPed).<br>Query byte order.<br>Select exponent precision (NORMAL or HPRecision). | ASCii<br><br><br>(Note)<br><br>SWAPPed<br><br>NORMAL | √<br>√<br><br><br><br>√<br>√ |

Note: READING is the \*RST default and All is the :SYSTEM:PRESet default.

**Table 3-7***INPut command summary*

| Command                                                                  | Description                                                                                                                                                                                     | Default parameter | SCPI |
|--------------------------------------------------------------------------|-------------------------------------------------------------------------------------------------------------------------------------------------------------------------------------------------|-------------------|------|
| :INPut<br>:PREamp<br>:STaTe <b><br>:STaTe?<br>:FILTer <name><br>:FILTer? | Path to control the Model 1801 Preamp:<br>Enable or disable the preamp.<br>Query the state of the preamp.<br>Select filter response (SLOW, MED or FAST).<br>Query the selected filter response. | OFF<br><br>MED    |      |

**Table 3-8***OUTput command summary*

| Command                                                                                                                                                               | Description                                                                                                                                                                                                                                                                                                                                                                                                                                                                                                                                                                      | Default Parameter | SCPI     |
|-----------------------------------------------------------------------------------------------------------------------------------------------------------------------|----------------------------------------------------------------------------------------------------------------------------------------------------------------------------------------------------------------------------------------------------------------------------------------------------------------------------------------------------------------------------------------------------------------------------------------------------------------------------------------------------------------------------------------------------------------------------------|-------------------|----------|
| :OUTPut<br>:TTL[1]<br>:LSEnse <name><br>:LSEnse?<br>:TTL2<br>:LSEnse <name><br>:LSEnse?<br>:TTL3<br>:LSEnse <name><br>:LSEnse?<br>:TTL4<br>:LSEnse <name><br>:LSEnse? | Path to set polarity of digital output line 1:<br>Select polarity; active high (AHIGH) or active low (ALOW).<br>Query polarity of line 1.<br>Path to set polarity of digital output line 2:<br>Select polarity; active high (AHIGH) or active low (ALOW).<br>Query polarity of line 2.<br>Path to set polarity of digital output line 3:<br>Select polarity; active high (AHIGH) or active low (ALOW).<br>Query polarity of line 3.<br>Path to set polarity of digital output line 4:<br>Select polarity; active high (AHIGH) or active low (ALOW).<br>Query polarity of line 4. | (Note 1)          | (Note 2) |

Notes:

1. None of the OUTPut subsystem commands are affected by \*RST and :SYSTem:PRESet.
2. All OUTPut subsystem commands are non-SCPI.



**Table 3-9***ROUTE command summary*

| Command                  | Description                                                        | Default parameter | SCPI | Ref.   |
|--------------------------|--------------------------------------------------------------------|-------------------|------|--------|
| :ROUTE                   |                                                                    |                   |      |        |
| :CLOSE <list>            | Path and command to close specified channel:                       |                   | √    | 3.17.1 |
| :STATe?                  | Query closed channel.                                              |                   | √    |        |
| :CLOSE? <list>           | Query specified channels (1 = closed, 0 = open).                   |                   | √    |        |
| :OPEN <list>             | Open specified channel or all channels.                            |                   | √    | 3.17.2 |
| :OPEN:ALL                | Open all channels.                                                 |                   | √    | 3.17.3 |
| :OPEN? <list>            | Query specified channels (1 = open, 0 = closed).                   |                   | √    |        |
| :SCAN                    | Command path to configure and control scan operations:             |                   | √    | 3.17.4 |
| [:INTERNAL] <list>       | Specify internal scan list (2 to 10 channels).                     | All 10            | √    |        |
| [:INTERNAL]?             | Query the internal scan list.                                      |                   | √    |        |
| :FUNCTION <list>, <name> | Assign function to specified channels.                             |                   |      |        |
| :FUNCTION? <list>        | Query function for each specified channel.                         |                   |      |        |
| :EXTERNAL <list>         | Specify external scan list (2 to 80 channels).                     | All 80            |      |        |
| :EXTERNAL?               | Query the external scan list.                                      |                   |      |        |
| :FUNCTION <list>, <name> | Assign measurement function to specified channels.                 | VOLT:DC           |      |        |
| :FUNCTION? <list>        | Query function for each specified channel.                         |                   |      |        |
| :RATio                   | Command path to configure ratio calculation:                       |                   |      |        |
| :RCHannel <list>         | Specify reference channel (1 to 10).                               | 5                 |      |        |
| :RCHannel?               | Query reference channel.                                           |                   |      |        |
| :MCHannel <list>         | Specify measure channel (1 to 10).                                 | 10                |      |        |
| :MCHannel?               | Query measure channel.                                             |                   |      |        |
| :DELTA                   | Command path to configure delta calculation:                       |                   |      |        |
| :RCHannel <list>         | Specify reference channel (1 to 10).                               | 5                 |      |        |
| :RCHannel?               | Query reference channel.                                           |                   |      |        |
| :MCHannel <list>         | Specify measure channel (1 to 10).                                 | 10                |      |        |
| :MCHannel?               | Query measure channel.                                             |                   |      |        |
| :LSElect <name>          | Select scan operation: (INTERNAL, EXTERNAL, RATio, DELTA or NONE). | NONE              |      |        |
| :LSElect?                | Query scan operation.                                              |                   |      |        |

**Table 3-10***SENSe command summary*

| Command          | Description                                                                                                                                  | Default parameter | SCPI | Ref.   |
|------------------|----------------------------------------------------------------------------------------------------------------------------------------------|-------------------|------|--------|
| [:SENSe[1]]      |                                                                                                                                              |                   |      | 3.18.1 |
| :ALternate[1]    | Path to control an Alternate setup.                                                                                                          |                   |      | 3.18.2 |
| :SAVE            | Save current setup as Alternate setup.                                                                                                       | (Note 1)          |      |        |
| :RECall          | Return instrument to Alternate setup.                                                                                                        |                   |      |        |
| :FUNCTION <name> | Select measurement function: 'VOLTage:AC', 'VOLTage:DC', 'RESistance', 'FRESistance', 'CURRent:AC', 'CURRent:DC', 'FREQuency', 'TEMPerature' | 'VOLT:DC'         | √    | 3.18.3 |
| :FUNCTION?       | Query function.                                                                                                                              |                   | √    |        |
| :DATA            | Path to read reading conversions:                                                                                                            |                   | √    | 3.18.4 |
| [:LATest]?       | Return the last instrument reading.                                                                                                          |                   | √    |        |
| :FRESH?          | Return a new (fresh) reading.                                                                                                                |                   | √    |        |

**Table 3-10 (Continued)**  
SENSe command summary

| Command            | Description                                       | Default parameter | SCPI | Ref.    |
|--------------------|---------------------------------------------------|-------------------|------|---------|
| :CURRent:AC        | Path to configure AC current.                     |                   | √    |         |
| :APERture <n>      | Set integration rate in seconds (166.67e-6 to 1). | (Note 2)          | √    | 3.18.5  |
| :AUTO <b>          | Enable or disable auto aperture.                  | OFF               |      |         |
| :AUTO ONCE         | Enable and then disable auto aperture.            |                   |      |         |
| :AUTO?             | Query auto aperture.                              |                   |      |         |
| :APERture?         | Query aperture (integration rate).                |                   | √    |         |
| :NPLCycles <n>     | Set integration rate (line cycles; 0.01 to 50).   | 1                 | √    | 3.18.6  |
| :AUTO <b>          | Enable or disable auto NPLC.                      | OFF               |      |         |
| :AUTO ONCE         | Enable and then disable auto NPLC                 |                   |      |         |
| :AUTO?             | Query auto line cycle integration.                |                   |      |         |
| :NPLCycles?        | Query line cycle integration rate.                |                   | √    |         |
| :COUPling AC DC    | Specify input coupling.                           | AC                |      | 3.18.7  |
| :COUPling?         | Query input coupling.                             |                   |      |         |
| :RANGe             | Path to configure measurement range:              |                   | √    | 3.18.8  |
| [:UPPer] <n>       | Select range (0 to +2.1).                         | 2.1               | √    |         |
| [:UPPer]?          | Query range.                                      |                   | √    |         |
| :AUTO <b>          | Enable or disable auto range.                     | ON                | √    |         |
| :AUTO ONCE         | Set range based on present input signal.          |                   | √    |         |
| :ULIMit <n>        | Set upper limit for auto range (0 to +2.1).       | 2.1               |      |         |
| :ULIMit?           | Query upper limit.                                |                   |      |         |
| :LLIMit <n>        | Set lower limit for auto range (0 to +2.1).       | 0.0002            |      |         |
| :LLIMit?           | Query lower limit.                                |                   |      |         |
| :AUTO?             | Query auto range.                                 |                   | √    |         |
| :REFeRence <n>     | Specify reference (-2.1 to +2.1).                 | 0                 | √    | 3.18.9  |
| :STATe <b>         | Enable or disable reference.                      | OFF               | √    |         |
| :STATe?            | Query state of reference.                         |                   | √    |         |
| :ACQuire           | Use input signal as reference.                    |                   |      |         |
| :REFeRence?        | Query reference value.                            |                   | √    |         |
| :DIGits <n>        | Specify measurement resolution (4 to 9).          | 7                 |      | 3.18.10 |
| :AUTO <b>          | Enable or disable auto resolution.                | ON                |      |         |
| :AUTO ONCE         | Enable and then disable auto resolution.          |                   |      |         |
| :AUTO?             | Query auto resolution.                            |                   |      |         |
| :DIGits?           | Query resolution.                                 |                   |      |         |
| :AVERAge           | Path to configure and control the filter.         |                   |      | 3.18.11 |
| :TCONtrol <name>   | Select filter type: (MOVing or REPeat).           | (Note 3)          |      |         |
| :TCONtrol?         | Query filter type.                                |                   |      |         |
| :COUNT <n>         | Specify filter count (1 to 100).                  |                   |      |         |
| :COUNT?            | Query filter count.                               | 10                |      |         |
| :ADVanced          | Path to configure and control advanced filter.    |                   |      |         |
| :NTOLerance <n>    | Specify noise tolerance level (0 to 100%).        | 5                 |      |         |
| :NTOLerance?       | Query noise tolerance level.                      |                   |      |         |
| [:STATe] <b>       | Enable or disable advanced filter.                | ON                |      |         |
| [:STATe]?          | Query state of advanced filter.                   |                   |      |         |
| [:STATe] <b>       | Enable or disable filter.                         | (Note 4)          |      |         |
| [:STATe]?          | Query state of digital filter.                    |                   |      |         |
| :AUTO <b>          | Enable or disable auto filter.                    | (Note 5)          |      |         |
| :AUTO ONCE         | Enable and then disable auto filter.              |                   |      |         |
| :AUTO?             | Query auto filter.                                |                   |      |         |
| :DETeCtor          | Path to select function:                          |                   |      | 3.18.12 |
| [:FUNction] <name> | Select type of AC measurement: RMS, AVERAge.      | RMS               |      |         |
| [:FUNction]?       | Query detector function.                          |                   |      |         |

**Table 3-10 (Continued)**  
SENSe command summary

| Command          | Description                                       | Default parameter | SCPI | Ref.    |
|------------------|---------------------------------------------------|-------------------|------|---------|
| :CURRent:DC      | Path to configure DC current.                     |                   | √    |         |
| :APERture <n>    | Set integration rate in seconds (166.67e-6 to 1). | (Note 2)          | √    | 3.18.5  |
| :AUTO <b>        | Enable or disable auto aperture.                  | OFF               |      |         |
| :AUTO ONCE       | Enable and then disable auto aperture.            |                   |      |         |
| :AUTO?           | Query auto aperture.                              |                   |      |         |
| :APERture?       | Query aperture (integration rate).                |                   | √    |         |
| :NPLCycles <n>   | Set integration rate (line cycles; 0.01 to 50).   | 1                 | √    | 3.18.6  |
| :AUTO <b>        | Enable or disable auto NPLC.                      | OFF               |      |         |
| :AUTO ONCE       | Enable and then disable auto NPLC.                |                   |      |         |
| :AUTO?           | Query auto line cycle integration.                |                   |      |         |
| :NPLCycles?      | Query line cycle integration rate.                |                   | √    |         |
| :RANGe           | Path to configure measurement range:              |                   | √    | 3.18.8  |
| [:UPPer] <n>     | Select range (0 to 2.1).                          | 2.1               | √    |         |
| [:UPPer]?        | Query range.                                      |                   | √    |         |
| :AUTO <b>        | Enable or disable auto range.                     | ON                | √    |         |
| :AUTO ONCE       | Set range based on present input signal.          |                   | √    |         |
| :ULIMit <n>      | Set upper limit for auto range (0 to 2.1).        | 2.1               |      |         |
| :ULIMit?         | Query upper limit.                                |                   |      |         |
| :LLIMit <n>      | Set lower limit for auto range (0 to 2.1).        | 0.0002            |      |         |
| :LLIMit?         | Query lower limit.                                |                   |      |         |
| :AUTO?           | Query auto range.                                 |                   | √    |         |
| :REFerence <n>   | Specify reference (-2.1 to +2.1).                 | 0                 | √    | 3.18.9  |
| :STATe <b>       | Enable or disable reference.                      | OFF               | √    |         |
| :STATe?          | Query state of reference.                         |                   | √    |         |
| :ACQuire         | Use input signal as reference.                    |                   |      |         |
| :REFerence?      | Query reference value.                            |                   | √    |         |
| :DIGits <n>      | Specify measurement resolution (4 to 9).          | 7                 |      | 3.18.10 |
| :AUTO <b>        | Enable or disable auto resolution.                | ON                |      |         |
| :AUTO ONCE       | Enable and then disable auto resolution.          |                   |      |         |
| :AUTO?           | Query auto resolution (0 or 1).                   |                   |      |         |
| :DIGits?         | Query resolution.                                 |                   |      |         |
| :AVERage         | Path to configure and control the filter.         |                   |      | 3.18.11 |
| :TCONtrol <name> | Select filter type: (MOVing or REPeat).           | (Note 3)          |      |         |
| :TCONtrol?       | Query filter type.                                |                   |      |         |
| :COUNT <n>       | Specify filter count (1 to 100).                  | 10                |      |         |
| :COUNT?          | Query filter count.                               |                   |      |         |
| :ADVanced        | Path to configure and control advanced filter.    |                   |      |         |
| :NTOLerance <n>  | Specify noise tolerance level (0 to 100%).        | 1                 |      |         |
| :NTOLerance?     | Query noise tolerance level.                      |                   |      |         |
| [:STATe] <b>     | Enable or disable advanced filter.                | ON                |      |         |
| [:STATe]?        | Query state of advanced filter.                   |                   |      |         |
| [:STATe] <b>     | Enable or disable filter.                         | (Note 4)          |      |         |
| [:STATe]?        | Query state of digital filter.                    |                   |      |         |
| :AUTO <b>        | Enable or disable auto filter.                    | (Note 5)          |      |         |
| :AUTO ONCE       | Enable and then disable auto filter.              |                   |      |         |
| :AUTO?           | Query auto filter.                                |                   |      |         |
| :METHod <name>   | Select measure technique: (NORMAL or ICIRcuit).   |                   |      | 3.18.14 |
| :METHod?         | Query method.                                     | NORMAL            |      |         |

**Table 3-10 (Continued)**  
SENSe command summary

| Command          | Description                                       | Default parameter | SCPI | Ref.    |
|------------------|---------------------------------------------------|-------------------|------|---------|
| :VOLTage:AC      | Path to configure AC voltage.                     |                   | √    |         |
| :APERTure <n>    | Set integration rate in seconds (166.67e-6 to 1). | (Note 2)          | √    | 3.18.5  |
| :AUTO <b>        | Enable or disable auto aperture.                  | OFF               |      |         |
| :AUTO ONCE       | Enable and then disable auto aperture.            |                   |      |         |
| :AUTO?           | Query auto aperture.                              |                   |      |         |
| :APERTure?       | Query aperture (integration rate).                |                   | √    |         |
| :NPLCycles <n>   | Set integration rate (line cycles; 0.01 to 50).   | 1                 | √    | 3.18.6  |
| :AUTO <b>        | Enable or disable auto NPLC.                      | OFF               |      |         |
| :AUTO ONCE       | Enable and then disable auto NPLC.                |                   |      |         |
| :AUTO?           | Query auto line cycle integration.                |                   |      |         |
| :NPLCycles?      | Query line cycle integration rate.                |                   | √    |         |
| :COUPling AC DC  | Specify input coupling.                           | AC                |      | 3.18.7  |
| :COUPling?       | Query input coupling.                             |                   |      |         |
| :RANGe           | Path to configure measurement range:              |                   | √    | 3.18.8  |
| [:UPPer] <n>     | Select range (0 to +775).                         | 775               | √    |         |
| [:UPPer]?        | Query range.                                      |                   | √    |         |
| :AUTO <b>        | Enable or disable auto range.                     | ON                | √    |         |
| :AUTO ONCE       | Set range based on present input signal.          |                   | √    |         |
| :ULIMit <n>      | Set upper limit for auto range (0 to +775).       | 775               |      |         |
| :ULIMit?         | Query upper limit.                                |                   |      |         |
| :LLIMit <n>      | Set lower limit for auto range (0 to +775).       | 0.2               |      |         |
| :LLIMit?         | Query lower limit.                                |                   |      |         |
| :AUTO?           | Query auto range.                                 |                   | √    |         |
| :REFerence <n>   | Specify reference (-1100 to 1100).                | 0                 | √    | 3.18.9  |
| :STATe <b>       | Enable or disable reference.                      | OFF               | √    |         |
| :STATe?          | Query state of reference.                         |                   | √    |         |
| :ACQuire         | Use input signal as reference.                    |                   |      |         |
| :REFerence?      | Query reference value.                            |                   | √    |         |
| :DIGits <n>      | Specify measurement resolution (4 to 9).          | 6                 |      | 3.18.10 |
| :AUTO <b>        | Enable or disable auto resolution.                | ON                |      |         |
| :AUTO ONCE       | Enable and then disable auto resolution.          |                   |      |         |
| :AUTO?           | Query auto resolution.                            |                   |      |         |
| :DIGits?         | Query resolution.                                 |                   |      |         |
| :AVERage         | Path to configure and control the filter.         |                   |      | 3.18.11 |
| :TCONtrol <name> | Select filter type: (MOVing or REPeat).           | (Note 3)          |      |         |
| :TCONtrol?       | Query filter type.                                |                   |      |         |
| :COUNT <n>       | Specify filter count (1 to 100).                  | 10                |      |         |
| :COUNT?          | Query filter count.                               |                   |      |         |
| :ADVanced        | Path to configure and control advanced filter.    |                   |      |         |
| :NTOLerance <n>  | Specify noise tolerance level (0 to 100%).        | 5                 |      |         |
| :NTOLerance?     | Query noise tolerance level.                      |                   |      |         |
| [:STATe] <b>     | Enable or disable advanced filter.                | ON                |      |         |
| [:STATe]?        | Query state of advanced filter.                   |                   |      |         |
| [:STATe] <b>     | Enable or disable filter.                         | (Note 4)          |      |         |
| [:STATe]?        | Query state of digital filter.                    |                   |      |         |
| :AUTO <b>        | Enable or disable auto filter.                    | (Note 5)          |      |         |
| :AUTO ONCE       | Enable and then disable auto filter.              |                   |      |         |
| :AUTO?           | Query auto filter.                                |                   |      |         |



**Table 3-10 (Continued)**  
SENSe command summary

| Command           | Description                                       | Default parameter | SCPI | Ref.    |
|-------------------|---------------------------------------------------|-------------------|------|---------|
| :RESistance       | Path to configure resistance:                     |                   | √    |         |
| :APERture <n>     | Set integration rate in seconds (166.67e-6 to 1). | (Note 2)          | √    | 3.18.5  |
| :AUTO <b>         | Enable or disable auto aperture.                  | OFF               |      |         |
| :AUTO ONCE        | Enable and then disable auto aperture.            |                   |      |         |
| :AUTO?            | Query auto aperture.                              |                   |      |         |
| :APERture?        | Query aperture.                                   |                   | √    |         |
| :NPLCycles <n>    | Set integration rate (line cycles; 0.01 to 50).   | 1                 | √    | 3.18.6  |
| :AUTO <b>         | Enable or disable auto NPLC.                      | OFF               |      |         |
| :AUTO ONCE        | Enable and then disable auto NPLC.                |                   |      |         |
| :AUTO?            | Query auto line cycle integration.                |                   |      |         |
| :NPLCycles?       | Query line cycle integration rate.                |                   | √    |         |
| :RANGe            | Path to configure measurement range:              |                   | √    | 3.18.8  |
| [:UPPer] <n>      | Select range (0 to 1.05e9).                       | 1.05e9            | √    |         |
| [:UPPer]?         | Query range.                                      |                   | √    |         |
| :AUTO <b>         | Enable or disable auto range.                     | ON                | √    |         |
| :AUTO ONCE        | Set range based on present input signal.          |                   | √    |         |
| :ULIMit <n>       | Set upper limit for auto range (0 to 1.05e9).     | 1.05e9            |      |         |
| :ULIMit?          | Query upper limit.                                |                   |      |         |
| :LLIMit <n>       | Set lower limit for auto range (0 to 1.05e9).     | 20                |      |         |
| :LLIMit?          | Query lower limit.                                |                   |      |         |
| :AUTO?            | Query auto range.                                 |                   | √    |         |
| :REFerence <n>    | Specify reference (0 to +1.05e9).                 | 0                 | √    | 3.18.9  |
| :STATe <b>        | Enable or disable reference.                      | OFF               | √    |         |
| :STATe?           | Query state of reference.                         |                   | √    |         |
| :ACQuire          | Use input signal as reference.                    |                   |      |         |
| :REFerence?       | Query reference value.                            |                   | √    |         |
| :DIGits <n>       | Specify measurement resolution (4 to 9).          | 8                 |      | 3.18.10 |
| :AUTO <b>         | Enable or disable auto resolution.                | ON                |      |         |
| :AUTO ONCE        | Enable and then disable auto resolution.          |                   |      |         |
| :AUTO?            | Query auto resolution.                            |                   |      |         |
| :DIGits?          | Query resolution.                                 |                   |      |         |
| :AVERage          | Path to configure and control filter.             |                   |      | 3.18.11 |
| :TCONtrol <name>  | Select filter type: (MOVing or REPeat).           |                   |      |         |
| :TCONtrol?        | Query filter type.                                | (Note 3)          |      |         |
| :COUNT <n>        | Specify filter count (1 to 100).                  |                   |      |         |
| :COUNT?           | Query filter count.                               | 10                |      |         |
| :ADVanced         | Path to configure and control advanced filter.    |                   |      |         |
| :NTOLerance <n>   | Specify noise tolerance level (0 to 100%).        |                   |      |         |
| :NTOLerance?      | Query noise tolerance level.                      | 1                 |      |         |
| [:STATe] <b>      | Enable or disable advanced filter.                | ON                |      |         |
| [:STATe]?         | Query state of advanced filter.                   |                   |      |         |
| [:STATe] <b>      | Enable or disable filter.                         |                   |      |         |
| [:STATe]?         | Query state of digital filter.                    | (Note 4)          |      |         |
| :AUTO <b>         | Enable or disable auto filter.                    |                   |      |         |
| :AUTO ONCE        | Enable and then disable auto filter.              | (Note 5)          |      |         |
| :AUTO?            | Query auto filter.                                |                   |      |         |
| :OCOMpensated <b> | Enable or disable Offset Compensation.            | OFF               | √    | 3.18.21 |
| :OCOMpensated?    | Query Offset Compensation.                        |                   | √    |         |

**Table 3-10 (Continued)**  
SENSe command summary

| Command           | Description                                       | Default parameter | SCPI | Ref.    |
|-------------------|---------------------------------------------------|-------------------|------|---------|
| :FRESistance      | Path to configure four-wire resistance:           |                   | √    |         |
| :APERTure <n>     | Set integration rate in seconds (166.67e-6 to 1). | (Note 2)          | √    | 3.18.5  |
| :AUTO <b>         | Enable or disable auto aperture.                  | OFF               |      |         |
| :AUTO ONCE        | Enable and then disable auto aperture.            |                   |      |         |
| :AUTO?            | Query auto aperture.                              |                   |      |         |
| :APERTure?        | Query aperture (integration rate).                |                   | √    |         |
| :NPLCycles <n>    | Set integration rate (line cycles; 0.01 to 50).   | 1                 | √    | 3.18.6  |
| :AUTO <b>         | Enable or disable auto NPLC.                      | OFF               |      |         |
| :AUTO ONCE        | Enable and then disable auto NPLC.                |                   |      |         |
| :AUTO?            | Query auto line cycle integration.                |                   |      |         |
| :NPLCycles?       | Query line cycle integration rate.                |                   | √    |         |
| :RANGe            | Path to configure measurement range:              |                   | √    | 3.18.8  |
| [:UPPer] <n>      | Select range (0 to 2.1e6).                        | 2.1e6             | √    |         |
| [:UPPer]?         | Query range.                                      |                   | √    |         |
| :AUTO <b>         | Enable or disable auto range.                     | ON                | √    |         |
| :AUTO ONCE        | Set range based on present input signal.          |                   | √    |         |
| :ULIMit <n>       | Set upper limit for auto range (0 to 2.1e6).      | 2.1e6             |      |         |
| :ULIMit?          | Query upper limit.                                |                   |      |         |
| :LLIMit <n>       | Set lower limit for auto range (0 to 2.1e6).      | 20                |      |         |
| :LLIMit?          | Query lower limit.                                |                   |      |         |
| :AUTO?            | Query auto range.                                 |                   | √    |         |
| :REFerence <n>    | Specify reference (0 to +2.1e6).                  | 0                 | √    | 3.18.9  |
| :STATe <b>        | Enable or disable reference.                      | OFF               | √    |         |
| :STATe?           | Query state of reference.                         |                   | √    |         |
| :ACQuire          | Use input signal as reference.                    |                   |      |         |
| :REFerence?       | Query reference value.                            |                   | √    |         |
| :DIGits <n>       | Specify measurement resolution (4 to 9).          | 8                 |      | 3.18.10 |
| :AUTO <b>         | Enable or disable auto resolution.                | ON                |      |         |
| :AUTO ONCE        | Enable and then disable auto resolution.          |                   |      |         |
| :AUTO?            | Query auto resolution.                            |                   |      |         |
| :DIGits?          | Query resolution.                                 |                   |      |         |
| :AVERage          | Path to configure and control filter.             |                   |      | 3.18.11 |
| :TCONtrol <name>  | Select filter type: (MOVing or REPeat).           | (Note 3)          |      |         |
| :TCONtrol?        | Query filter type.                                |                   |      |         |
| :COUNT <n>        | Specify filter count (1 to 100).                  | 10                |      |         |
| :COUNT?           | Query filter count.                               |                   |      |         |
| :ADVanced         | Path to configure and control advanced filter.    |                   |      |         |
| :NTOLerance <n>   | Specify noise tolerance level (0 to 100%).        | 1                 |      |         |
| :NTOLerance?      | Query noise tolerance level.                      |                   |      |         |
| [:STATe] <b>      | Enable or disable advanced filter.                | ON                |      |         |
| [:STATe]?         | Query state of advanced filter.                   |                   |      |         |
| [:STATe] <b>      | Enable or disable filter.                         | (Note 4)          |      |         |
| [:STATe]?         | Query state of digital filter.                    |                   |      |         |
| :AUTO <b>         | Enable or disable auto filter.                    | (Note 5)          |      |         |
| :AUTO ONCE        | Enable and then disable auto filter.              |                   |      |         |
| :AUTO?            | Query auto filter.                                |                   |      |         |
| :OCOMpensated <b> | Enable or disable Offset Compensation.            | OFF               | √    | 3.18.21 |
| :OCOMpensated?    | Query Offset Compensation.                        |                   | √    |         |

**Table 3-10 (Continued)**  
SENSe command summary

| Command                                                                                                                                                                                                                                                                                                                      | Description                                                                                                                                                                                                                                                                                                                                                                                                                                                                                                                                                                                                                                                                                                                                                                                  | Default parameter                                       | SCPI | Ref.                                              |
|------------------------------------------------------------------------------------------------------------------------------------------------------------------------------------------------------------------------------------------------------------------------------------------------------------------------------|----------------------------------------------------------------------------------------------------------------------------------------------------------------------------------------------------------------------------------------------------------------------------------------------------------------------------------------------------------------------------------------------------------------------------------------------------------------------------------------------------------------------------------------------------------------------------------------------------------------------------------------------------------------------------------------------------------------------------------------------------------------------------------------------|---------------------------------------------------------|------|---------------------------------------------------|
| :FREQuency<br>:COUPling AC DC<br>:COUPling?<br>:REFEreNce <n><br>:STATe <b><br>:STATe?<br>:ACQuire<br>:REFEreNce?<br>:DIGits <n><br>:DIGits?<br>:SOURce <name><br>:SOURce?<br>:THREshold<br>:CURRent<br>:RANGe <n><br>:RANGe?<br>:LEVel <n><br>:LEVel?<br>:VOLTage<br>:RANGe <n><br>:RANGe?<br>:LEVel <n><br>:LEVel?<br>:TTL | Path to configure frequency:<br>Specify input coupling.<br>Query input coupling.<br>Specify reference (0 to 15e6).<br>Enable or disable reference.<br>Query state of reference.<br>Use input signal as reference.<br>Query reference value.<br>Specify measurement resolution (4 or 5).<br>Query resolution.<br>Select source: (CURRent or VOLTage).<br>Query source.<br>Path to configure threshold:<br>Path to set current threshold:<br>Specify range (0 to 1).<br>Query range.<br>Specify threshold level.<br>Query threshold level.<br>Path to set voltage threshold:<br>Specify range (0 to 1000).<br>Query range.<br>Specify threshold level.<br>Query threshold level.<br>Set threshold to TTL level.                                                                                | AC<br>0<br>OFF<br>5<br>VOLTage<br>0.001<br>0<br>10<br>0 |      | 3.18.7<br>3.18.9<br>3.18.10<br>3.18.15<br>3.18.16 |
| :TEMPerature<br>:APERture <n><br>:AUTO <b><br>:AUTO ONCE<br>:AUTO?<br>:APERture?<br>:NPLCycles <n><br>:AUTO <b><br>:AUTO ONCE<br>:AUTO?<br>:NPLCycles?<br>:REFEreNce <n><br>:STATe <b><br>:STATe?<br>:ACQuire<br>:REFEreNce?<br>:DIGits <n><br>:AUTO <b><br>:AUTO ONCE<br>:AUTO?<br>:DIGits?                                 | Path to configure four-wire resistance:<br>Set integration rate in seconds (166.67e-6 to 1).<br>Enable or disable auto aperture.<br>Enable and then disable auto aperture.<br>Query auto aperture.<br>Query aperture (integration rate).<br>Set integration rate (line cycles; 0.01 to 50).<br>Enable or disable auto NPLC.<br>Enable and then disable auto NPLC.<br>Query auto line cycle integration.<br>Query line cycle integration rate.<br>Specify reference; -200 to +1821 (°C)<br>Enable or disable reference.<br>Query state of reference.<br>Use input signal as reference.<br>Query reference value.<br>Specify measurement resolution (4 to 7).<br>Enable or disable auto resolution.<br>Enable and then disable auto resolution.<br>Query auto resolution.<br>Query resolution. | (Note 2)<br>OFF<br>1<br>OFF<br>0<br>OFF<br>6<br>ON      |      | 3.18.5<br>3.18.6<br>3.18.9<br>3.18.10             |



**Table 3-10 (Continued)**  
SENSe command summary

| Command                                                                                                                                                                                                                                                                                                                                                                                                                                                                                                                                                                                                                                                                                  | Description                                                                                                                                                                                                                                                                                                                                                                                                                                                                                                                                                                                                                                                                                                                                                                                                                                                                                                                                                                                                                                                                                                                                                                                                                                                                                                                                                                                                                                                                                                                                                                                                                                                                                                                                                | Default parameter                                                                                                                                                                                                                                     | SCPI | Ref.                                                                       |
|------------------------------------------------------------------------------------------------------------------------------------------------------------------------------------------------------------------------------------------------------------------------------------------------------------------------------------------------------------------------------------------------------------------------------------------------------------------------------------------------------------------------------------------------------------------------------------------------------------------------------------------------------------------------------------------|------------------------------------------------------------------------------------------------------------------------------------------------------------------------------------------------------------------------------------------------------------------------------------------------------------------------------------------------------------------------------------------------------------------------------------------------------------------------------------------------------------------------------------------------------------------------------------------------------------------------------------------------------------------------------------------------------------------------------------------------------------------------------------------------------------------------------------------------------------------------------------------------------------------------------------------------------------------------------------------------------------------------------------------------------------------------------------------------------------------------------------------------------------------------------------------------------------------------------------------------------------------------------------------------------------------------------------------------------------------------------------------------------------------------------------------------------------------------------------------------------------------------------------------------------------------------------------------------------------------------------------------------------------------------------------------------------------------------------------------------------------|-------------------------------------------------------------------------------------------------------------------------------------------------------------------------------------------------------------------------------------------------------|------|----------------------------------------------------------------------------|
| :TEMPerature<br>AVERage<br>:TCONtrol <name><br>:TCONtrol?<br>:COUnT <n><br>:COUnT?<br>[:STATe] <b><br>[:STATe]?<br>:AUTO <b><br>[:STATe] <b><br>[:STATe]?<br>:AUTO <b><br>:AUTO ONCE<br>:AUTO?<br>:TRANsducer <name><br>:TRANsducer?<br>:RTD<br>:TYPE <name><br>:TYPE?<br>:ALPHa <NRf><br>:ALPHa?<br>:BETA <NRf><br>:BETA?<br>:DELTA <NRf><br>:DELTA?<br>:RZERo <NRf><br>:RZERo?<br>:SPRTD<br>:RZERo <NRf><br>:A4 <NRf><br>:B4 <NRf><br>:A7 <NRf><br>:B7 <NRf><br>:C7 <NRf><br>:TCouple<br>:TYPE <name><br>:TYPE?<br>:RJUNctionX<br>:RSElect <name><br>:RSElect?<br>:SIMulated <n><br>:SIMulated?<br>:REAL<br>:TCoefficient <n><br>:TCoefficient?<br>:OFFSet <n><br>:OFFSet?<br>:ACquire | <p>Path to configure and control the filter.</p> <p>Select filter type: (MOVing or REPeat).</p> <p>Query filter type.</p> <p>Specify filter count (1 to 100).</p> <p>Query filter count.</p> <p>Enable or disable filter.</p> <p>Query state of digital filter.</p> <p>Enable or disable auto filter.</p> <p>Enable or disable filter.</p> <p>Query state of digital filter.</p> <p>Enable or disable auto filter.</p> <p>Enable and then disable auto filter.</p> <p>Query auto filter.</p> <p>Select transducer: (RTD, FRTD, TCouple, DTC, or INTer-nal).</p> <p>Query transducer.</p> <p>Path to configure RTD measurements:</p> <p>Select RTD parameters: (PT100, D100, F100, PT385, PT3916, USER, or SPRTD).</p> <p>Query RTD type.</p> <p>Specify constant for USER type (0 to 0.01).</p> <p>Query alpha.</p> <p>Specify constant for USER type (0 to 1).</p> <p>Query beta.</p> <p>Specify constant for USER type (0 to 5).</p> <p>Query delta.</p> <p>Specify constant for USER type (0 to 1000).</p> <p>Query rzero.</p> <p>Set RTD zero value.</p> <p>Set A4 coefficient.</p> <p>Set B4 coefficient.</p> <p>Set A7 coefficient.</p> <p>Set B7 coefficient.</p> <p>Set C7 coefficient.</p> <p>Path to configure TC measurements:</p> <p>Select thermocouple type: (J, T, K, E, R, S, B, or N).</p> <p>Query TC type.</p> <p>Path to configure reference junctions (X = 1 to 5).</p> <p>Select reference type: (SIMulated or REAL).</p> <p>Query reference type.</p> <p>Specify simulated temperature.</p> <p>Query simulated temperature.</p> <p>Command path to specify “real” reference junction.</p> <p>Specify TC</p> <p>Query TC</p> <p>Specify voltage offset at 0°C.</p> <p>Query voltage offset.</p> <p>Update reference temperature.</p> | <p>(Note 3)</p> <p>10</p> <p>(Note 4)</p> <p>(Note 5)</p> <p>(Note 4)</p> <p>(Note 5)</p> <p>FRTD</p> <p>PT100</p> <p>0.00385</p> <p>0.111</p> <p>1.507</p> <p>100</p> <p>100</p> <p>J</p> <p>SIMulated</p> <p>23°C</p> <p>0.00002</p> <p>0.05463</p> |      | <p>3.18.11</p> <p>3.18.17</p> <p>3.18.18</p> <p>3.18.19</p> <p>3.18.20</p> |

**Table 3-10 (Continued)**  
SENSe command summary

| Command                                                                                                                              | Description                                                                                                                                                                                                                                                                                                                                                                                                                                                                            | Default parameter | SCPI | Ref.    |
|--------------------------------------------------------------------------------------------------------------------------------------|----------------------------------------------------------------------------------------------------------------------------------------------------------------------------------------------------------------------------------------------------------------------------------------------------------------------------------------------------------------------------------------------------------------------------------------------------------------------------------------|-------------------|------|---------|
| :TEMPerature<br>:DTCouple<br>:TYPE <type><br><br>:TYPE<br>:USLope <n><br><br>:USLope?<br><br>:RTEMPerature <n><br><br>:RTEMPerature? | Differential path.<br>Select thermocouple type (<type> = J K T E R S B N USER).<br>Return thermocouple type (J K T E R S B N USER).<br>Select thermocouple slope (<n> = slope in V/°C, 0 is invalid).<br>Return thermocouple slope (V/°C min = -0.099999; max = 0.099999; default = 20E-6).<br>Select reference thermocouple temperature (<n> = reference temperature in degrees)<br>Return thermocouple reference temperature in degrees; min = -273°C; max = 2000°C; default = 0°C). |                   |      | 3.18.22 |
| :SENSe2<br>:TTL[1]<br>:DATA?                                                                                                         | Path to read digital input port:<br>Query (read) the digital input port.                                                                                                                                                                                                                                                                                                                                                                                                               |                   |      | 3.18.23 |

## Notes:

1. The saved alternate setup is lost when power is cycled, or if \*RST or :SYSTem:PRESet is sent over the bus.
2. The default parameter is power line cycle integration; 16.67msec for 60Hz power line and 20msec for 50Hz or 400Hz power line.
3. REPEAT is the \*RST default parameter and MOVing is the :SYSTem:PRESet default parameter.
4. The \*RST default parameter is OFF for all functions. The :SYSTem:PRESet default is OFF for ACI, ACV and TEMP, and ON for DCI, DCV, Ω2 and Ω4.
5. The \*RST default parameter is OFF for all functions. The :SYSTem:PRESet default parameter is ON for ACI, DCI, ACV, DCV, Ω2 and Ω4, and OFF for TEMP.

**Table 3-11**  
SOURce command summary

| Command                                                                                                                                                                 | Description                                                                                                                                                                                                                                                                                                                                                                                          | Default parameter | SCPI     |
|-------------------------------------------------------------------------------------------------------------------------------------------------------------------------|------------------------------------------------------------------------------------------------------------------------------------------------------------------------------------------------------------------------------------------------------------------------------------------------------------------------------------------------------------------------------------------------------|-------------------|----------|
| :SOURce<br>:TTL[1][:LEVel] <b><br>:TTL[1][:LEVel]?<br>:TTL2[:LEVel] <b><br>:TTL2[:LEVel]?<br>:TTL3[:LEVel] <b><br>:TTL3[:LEVel]?<br>:TTL4[:LEVel] <b><br>:TTL4[:LEVel]? | Set digital output line #1 true (1 or ON) or false (0 or OFF).<br>Query digital output line 1.<br>Set digital output line #2 true (1 or ON) or false (0 or OFF).<br>Query digital output line 2.<br>Set digital output line #3 true (1 or ON) or false (0 or OFF).<br>Query digital output line 3.<br>Set digital output line #4 true (1 or ON) or false (0 or OFF).<br>Query digital output line 4. | (Note 1)          | (Note 2) |

## Notes:

1. \*RST and :SYSTem:PRESet have no affect on the state of the output lines. However, cycling power sets all output lines false (OFF).
2. All :SOURce subsystem commands are non-SCPI.

Table 3-12

STATUS command summary

| Command            | Description                                  | Default parameter | SCPI | Ref.   |
|--------------------|----------------------------------------------|-------------------|------|--------|
| :STATus            |                                              |                   | √    |        |
| :MEASurement       | Path to control measurement event registers: |                   |      |        |
| [:EVENT]?          | Read the event register.                     | (Note 2)          |      | 3.20.1 |
| :ENABle <NRf>      | Program the enable register.                 | (Note 3)          |      | 3.20.2 |
| :ENABle?           | Read the enable register.                    |                   |      |        |
| :PTRansition <NRf> | Program the positive transition register.    | (Note 4)          |      | 3.20.3 |
| :PTRansition?      | Read the positive transition register.       |                   |      |        |
| :NTRansition <NRf> | Program the negative transition register.    | (Note 5)          |      | 3.20.4 |
| :NTRansition?      | Read the negative transition register.       |                   |      |        |
| :CONDition?        | Read the condition register.                 |                   |      | 3.20.5 |
| :OPERation         | Path to control operation status registers:  |                   | √    |        |
| [:EVENT]?          | Read the event register.                     | (Note 2)          | √    | 3.20.1 |
| :ENABle <NRf>      | Program the enable register.                 | (Note 3)          | √    | 3.20.2 |
| :ENABle?           | Read the enable register.                    |                   | √    |        |
| :PTRansition <NRf> | Program the positive transition register.    | (Note 4)          | √    | 3.20.3 |
| :PTRansition?      | Read the positive transition register.       |                   | √    |        |
| :NTRansition <NRf> | Program the negative transition register.    | (Note 5)          | √    | 3.20.4 |
| :NTRansition?      | Read the negative transition register.       |                   | √    |        |
| :CONDition?        | Read the condition register.                 |                   | √    | 3.20.5 |
| :ARM               | Path to control arm event registers:         |                   | √    |        |
| [:EVENT]?          | Read the event register.                     | (Note 2)          | √    | 3.20.1 |
| :ENABle <NRf>      | Program the enable register.                 | (Note 3)          | √    | 3.20.2 |
| :ENABle?           | Read the enable register.                    |                   | √    |        |
| :PTRansition <NRf> | Program the positive transition register.    | (Note 4)          | √    | 3.20.3 |
| :PTRansition?      | Read the positive transition register.       |                   | √    |        |
| :NTRansition <NRf> | Program the negative transition register.    | (Note 5)          | √    | 3.20.4 |
| :NTRansition?      | Read the negative transition register.       |                   | √    |        |
| :CONDition?        | Read the condition register.                 |                   | √    | 3.20.5 |
| :SEQuence          | Path to control sequence status registers:   |                   | √    |        |
| [:EVENT]?          | Read the event register.                     | (Note 2)          | √    | 3.20.1 |
| :ENABle <NRf>      | Program the enable register.                 | (Note 3)          | √    | 3.20.2 |
| :ENABle?           | Read the enable register.                    |                   | √    |        |
| :PTRansition <NRf> | Program the positive transition register.    | (Note 4)          | √    | 3.20.3 |
| :PTRansition?      | Read the positive transition register.       |                   | √    |        |
| :NTRansition <NRf> | Program the negative transition register.    | (Note 5)          | √    | 3.20.4 |
| :NTRansition?      | Read the negative transition register.       |                   | √    |        |
| :CONDition?        | Read the condition register.                 |                   | √    | 3.20.5 |
| :TRIGger           | Path to control trigger status registers:    |                   | √    |        |
| [:EVENT]?          | Read the event register.                     | (Note 2)          | √    | 3.20.1 |
| :ENABle <NRf>      | Program the enable register.                 | (Note 3)          | √    | 3.20.2 |
| :ENABle?           | Read the enable register.                    |                   | √    |        |
| :PTRansition <NRf> | Program the positive transition register.    | (Note 4)          | √    | 3.20.3 |
| :PTRansition?      | Read the positive transition register.       |                   | √    |        |
| :NTRansition <NRf> | Program the negative transition register.    | (Note 5)          | √    | 3.20.4 |
| :NTRansition?      | Read the negative transition register.       |                   | √    |        |
| :CONDition?        | Read the condition register.                 |                   | √    | 3.20.5 |

**Table 3-12 (Continued)**  
**STATus command summary**

| Command                    | Description                                                                | Default parameter | SCPI | Ref.   |
|----------------------------|----------------------------------------------------------------------------|-------------------|------|--------|
| :STATus                    |                                                                            |                   |      |        |
| :QUESTionable<br>[:EVENT]? | Path to control questionable status registers:<br>Read the event register. | (Note 2)          | √    | 3.20.1 |
| :ENABle <NRf>              | Program the enable register.                                               | (Note 3)          | √    | 3.20.2 |
| :ENABle?                   | Read the enable register.                                                  |                   | √    |        |
| :PTRansition <NRf>         | Program the positive transition register.                                  | (Note 4)          | √    | 3.20.3 |
| :PTRansition?              | Read the positive transition register.                                     |                   | √    |        |
| :NTRansition <NRf>         | Program the negative transition register.                                  | (Note 5)          | √    | 3.20.4 |
| :NTRansition?              | Read the negative transition register.                                     |                   | √    |        |
| :CONDition?                | Read the condition register.                                               |                   | √    | 3.20.5 |
| :PRESet                    | Return status registers to default states.                                 |                   | √    | 3.20.6 |
| :QUEue                     | Path to access error queue:                                                |                   | √    | 3.20.7 |
| [:NEXT]?                   | Read the most recent error message.                                        | (Note 6)          | √    |        |
| :ENABle <list>             | Specify error and status messages for queue.                               | (Note 7)          | √    |        |
| :ENABle?                   | Read the enabled messages.                                                 |                   | √    |        |
| :DISABle <list>            | Specify messages not to be placed in queue.                                | (Note 7)          |      |        |
| :DISABle?                  | Read the disabled messages.                                                |                   |      |        |
| :CLEar                     | Clears all messages from Error Queue.                                      |                   |      |        |

## Notes:

- Commands in this subsystem are not affected by \*RST and :SYSTem:PRESet. The effects of cycling power, \*CLS and :STATus:PRESet are explained by the following notes.
- Event Registers: Power-up and \*CLS – Clears all bits of the registers  
:STATus:PRESet – No effect.
- Enable Registers: Power-up and :STATus:PRESet – Clears all bits of the registers  
\*CLS – No effect
- PTR Registers: Power-up and :STATus:PRESet sets all bits of the registers  
\*CLS – No effect
- NTR Registers: Power-up and :STATus:PRESet clears all bits of the registers  
\*CLS – No effect
- Error Queue: Power-up and \*CLS – Clears the Error Queue  
:STATus:PRESet – No effect
- Enable/Disable Error Queue Messages: Power-up – Clears list of messages  
\*CLS and :STATus:PRESet – No effect

Table 3-13

SYSTem command summary

| Command                  | Description                                                             | Default parameter | SCPI | Ref     |
|--------------------------|-------------------------------------------------------------------------|-------------------|------|---------|
| :SYSTem                  |                                                                         |                   |      |         |
| :PRESet                  | Return to :SYST:PRESet defaults.                                        |                   | √    | 3.21.1  |
| :POSetup <name>          | Select power-on setup: (RST, PRESet or SAV0-SAV9).                      |                   |      | 3.21.2  |
| :POSetup?                | Query power-on setup.                                                   |                   |      |         |
| :FRSWitch?               | Query INPUTS switch (0 = rear, 1 = front).                              |                   |      | 3.21.3  |
| :VERSion?                | Query rev level of SCPI standard.                                       |                   | √    | 3.21.4  |
| :ERRor?                  | Query (read) Error Queue.                                               | (Note)            | √    | 3.21.5  |
| :AZERo                   | Path to set up autozero.                                                |                   |      | 3.21.6  |
| :TYPE <name>             | Select autozero mode: (NORMal or SYNChronous).                          | SYNC              |      |         |
| :TYPE?                   | Query autozero mode.                                                    |                   |      |         |
| :STATe <b>               | Enable or disable autozero.                                             | ON                |      |         |
| :STATe?                  | Query autozero.                                                         |                   |      |         |
| :AMethod <name>          | Select reading acquisition method: (BURSt, NORMal, ASTReam or SSTReam). | NORMal            |      | 3.21.7  |
| :AMethod?                | Query acquisition method.                                               |                   |      |         |
| :LSYNc                   | Path to control line synchronization of measurements.                   |                   |      | 3.21.8  |
| :STATe <b>               | Enable or disable line sync.                                            | OFF               |      |         |
| :STATe?                  | Query line sync.                                                        |                   |      |         |
| :KEY <NRf>               | Simulate key-press (1 to 31; see Figure 3-39).                          |                   | √    | 3.21.9  |
| :KEY?                    | Query the last “pressed” key.                                           |                   | √    |         |
| :CLear                   | Clears messages from the Error Queue.                                   |                   |      | 3.21.10 |
| :LFRequency?             | Query frequency of line power.                                          |                   |      | 3.21.11 |
| :DATE <yr>, <mo>, <day>  | Set date.                                                               |                   |      | 3.21.12 |
| :DATE?                   | Query date.                                                             |                   |      |         |
| :TIME <hr>, <min>, <sec> | Set time (24-hour format).                                              |                   |      | 3.21.13 |
| :TIME?                   | Query time.                                                             |                   |      |         |
| :TSTamp                  | Path to configure and control timestamp.                                |                   |      | 3.21.14 |
| :TYPE <name>             | Select timestamp type (RELative or RTClock).                            |                   |      |         |
| :TYPE?                   | Query timestamp type.                                                   |                   |      |         |
| :RELative                | Path to reset timestamp.                                                |                   |      |         |
| :RESet                   | Reset relative timestamp to 0 sec.                                      |                   |      |         |
| :RNUMber                 | Path to reset reading number.                                           |                   |      | 3.21.15 |
| :RESet                   | Reset reading number of zero.                                           |                   |      |         |

Note: Clearing the Error Queue: Power-up and \*CLS – Clears the Error Queue  
 \*RST, :SYSTem:PRESet and :STATus:PRESet – No effect

**Table 3-14**  
TRACe command summary

| Command         | Description                                                       | Power-up defaults* | SCPI | Ref.   |
|-----------------|-------------------------------------------------------------------|--------------------|------|--------|
| :TRACe[:DATA]   | Use :TRACe or :DATA as root command.                              |                    |      |        |
| :CLEAr          | Clear readings from buffer.                                       |                    |      | 3.22.1 |
| :FREE?          | Query bytes available and bytes in use.                           |                    | √    | 3.22.2 |
| :EGROup <name>  | Select element group (FULL or COMPact).                           |                    |      | 3.22.3 |
| :EGROup?        | Query element group.                                              |                    |      |        |
| :POINts <n>     | Specify size of buffer.                                           |                    | √    | 3.22.4 |
| :AUTO <b>       | Enable or disable auto buffer sizing.                             |                    | √    |        |
| :AUTO?          | Query state of auto buffer sizing.                                |                    | √    |        |
| :POINts?        | Query buffer size.                                                |                    | √    |        |
| :FEED <name>    | Select source of readings (SENSE[1], CALCulate[1], NONE).         |                    | √    | 3.22.5 |
| :PRETrigger     | Path to configure pre-trigger storage.                            |                    |      |        |
| :AMOUnt         | Path to specify number of pre-trigger readings.                   |                    |      |        |
| [:PERCent] <n>  | Specify % (0 to 100) of buffer.                                   |                    |      |        |
| [:PERCent]?     | Query percentage.                                                 |                    |      |        |
| :READings <n>   | Specify as a number.                                              |                    |      |        |
| :READings?      | Query number of readings.                                         |                    |      |        |
| :SOURce <name>  | Select pre-trigger source event (EXTernal, TLINK, BUS or MANual). |                    |      |        |
| :SOURce?        | Query pre-trigger source event.                                   |                    |      |        |
| :CONTRol <name> | Select buffer control mode (NEVer, NEXT, ALWays or PRETrigger).   |                    | √    |        |
| :CONTRol?       | Query buffer control mode.                                        |                    | √    |        |
| :FEED?          | Query source of readings for buffer.                              |                    | √    |        |
| :DATA?          | Read all readings in the buffer.                                  |                    | √    | 3.22.6 |
| :TSTamp         | Path to select timestamp format for buffer readings.              |                    |      | 3.22.7 |
| :FORMat <name>  | Select timestamp format (ABSolute or DELTA).                      |                    |      |        |
| :FORMat?        | Query timestamp format.                                           |                    |      |        |

\*:SYSTem:PRESet and \*RST have no effect on the commands in this subsystem.

**Table 3-15**  
Trigger command summary

| Command         | Description                              | Default parameter | SCPI | Ref.   |
|-----------------|------------------------------------------|-------------------|------|--------|
| :INITiate       | Subsystem command path:                  |                   | √    | 3.23.1 |
| [:IMMEDIATE]    | Initiate one trigger cycle.              |                   | √    |        |
| :CONTInuous <b> | Enable or disable continuous initiation. | (Note 1)          | √    |        |
| :CONTInuous?    | Query continuous initiation.             |                   | √    |        |
| :ABORt          | Reset trigger system.                    |                   | √    | 3.23.2 |

**Table 3-15 (Continued)**  
Trigger command summary

| Command                  | Description                                                                       | Default parameter | SCPI     | Ref.    |
|--------------------------|-----------------------------------------------------------------------------------|-------------------|----------|---------|
| :ARM[:SEquence[1]]       | Path to configure arm layers:                                                     |                   | √        |         |
| [:LAYer[1]]              | Path to program Arm Layer 1:                                                      |                   | √        |         |
| :IMMediate               | Loop around control source.                                                       |                   | √        | 3.23.3  |
| :COUNT <n>               | Specify arm count (1 to 99999, or INF).                                           | 1                 | √        | 3.23.4  |
| :COUNT?                  | Query arm count.                                                                  |                   | √        |         |
| :SOURce <name>           | Select control source (HOLD, IMMEDIATE, RTCLock, MANual, BUS, TLINK or EXTERNAL). | IMMEDIATE         | (Note 2) | 3.23.6  |
| :SOURce?                 | Query control source.                                                             |                   | √        |         |
| :SIGNAL                  | Loop around control source.                                                       |                   | √        | 3.23.8  |
| :TCONfigure              | Path to configure Triggers:                                                       |                   |          | 3.23.9  |
| :DIRection <name>        | Enable (SOURCE) or disable (ACCEPTOR).                                            |                   |          |         |
| :DIRection?              | Query direction.                                                                  | ACCEPTOR          |          |         |
| :ASYNchronous            | Path to configure asynchronous Trigger Link:                                      |                   |          |         |
| :ILINE <NRf>             | Select input line (1 to 6).                                                       |                   |          |         |
| :ILINE?                  | Query input line.                                                                 | 2                 |          |         |
| :OLINE <NRf>             | Select output line (1 to 6).                                                      |                   |          |         |
| :OLINE?                  | Query output line.                                                                | 1                 |          |         |
| :RTCLock                 | Path to configure the RTCLock control source:                                     |                   |          | 3.23.10 |
| :DATE <yr>, <mo>, <day>  | Specify the date for the clock event.                                             |                   |          |         |
| :DATE?                   | Query the date for the clock event.                                               |                   |          |         |
| :TIME <hr>, <min>, <sec> | Specify the time for the clock event.                                             |                   |          |         |
| :TIME?                   | Query the time for the clock event.                                               |                   |          |         |
| :LAYer2                  | Path to program Arm Layer 2:                                                      |                   | √        |         |
| :IMMediate               | Loop around control source.                                                       |                   | √        | 3.23.3  |
| :COUNT <n>               | Specify scan count (1 to 99999 or INF).                                           | (Note 3)          | √        | 3.23.4  |
| :COUNT?                  | Query scan count.                                                                 |                   | √        |         |
| :DELay <n>               | Program delay (0 to 999999.999 sec).                                              | 0                 | √        | 3.23.5  |
| :DELay?                  | Query delay.                                                                      |                   | √        |         |
| :SOURce <name>           | Select control source (HOLD, IMMEDIATE, TIMER, MANual, BUS, TLINK or EXTERNAL).   | IMMEDIATE         | (Note 2) | 3.23.6  |
| :SOURce?                 | Query control source.                                                             |                   | √        |         |
| :TIMer <n>               | Set timer interval (0.001 to 999999.999 sec).                                     | 1                 | √        | 3.23.7  |
| :TIMer?                  | Query timer.                                                                      |                   | √        |         |
| :SIGNAL                  | Loop around control source.                                                       |                   | √        | 3.23.8  |
| :TCONfigure              | Path to configure Triggers:                                                       |                   |          | 3.23.9  |
| :DIRection <name>        | Enable (SOURCE) or disable (ACCEPTOR) Bypass.                                     |                   |          |         |
| :DIRection?              | Query direction.                                                                  | ACCEPTOR          |          |         |
| :ASYNchronous            | Path to configure asynchronous Trigger Link:                                      |                   |          |         |
| :ILINE <NRf>             | Select input line (1 to 6).                                                       |                   |          |         |
| :ILINE?                  | Query input line.                                                                 | 2                 |          |         |
| :OLINE <NRf>             | Select output line (1 to 6).                                                      |                   |          |         |
| :OLINE?                  | Query output line.                                                                | 1                 |          |         |
| :TRIGger[:SEquence[1]]   | Path to program Trigger Layer:                                                    |                   | √        |         |
| :IMMediate               | Loop around control source.                                                       |                   | √        | 3.23.3  |
| :COUNT <n>               | Set measure count (1 to 99999, or INF).                                           | (Note 3)          | √        | 3.23.4  |
| :COUNT?                  | Query measure count.                                                              |                   | √        |         |
| :DELay <n>               | Set delay (0 to 999999.999 sec).                                                  | 0                 | √        | 3.23.5  |
| :DELay?                  | Query delay.                                                                      |                   | √        |         |
| :SOURce <name>           | Select control source (HOLD, IMMEDIATE, TIMER, MANual, BUS, TLINK or EXTERNAL).   | IMMEDIATE         | (Note 2) | 3.23.6  |
| :SOURce?                 | Query control source.                                                             |                   | √        |         |

**Table 3-15 (Continued)**

Trigger command summary

| Command                        | Description                                      | Default parameter | SCPI | Ref.   |
|--------------------------------|--------------------------------------------------|-------------------|------|--------|
| <i>:TRIGger[:SEQuence[1]]</i>  |                                                  |                   |      |        |
| <i>:TImEr &lt;n&gt;</i>        | Set timer interval (0.001 to 999999.999 sec).    | 0.1               | √    | 3.23.7 |
| <i>:TImEr?</i>                 | Request the programmed timer interval.           |                   | √    |        |
| <i>:SIGNAL</i>                 | Loop around control source.                      |                   | √    | 3.23.8 |
| <i>:TCONfigure</i>             | Path to configure Triggers:                      |                   |      | 3.23.9 |
| <i>:PROTOcol &lt;name&gt;</i>  | Select protocol (ASYNchronous or SSYNchronous).  | ASYNchronous      |      |        |
| <i>:PROTOcol?</i>              | Query protocol.                                  |                   |      |        |
| <i>:DIRection &lt;name&gt;</i> | Enable (SOURce) or disable (ACCEptor) Bypass.    | ACCEptor          |      |        |
| <i>:DIRection?</i>             | Query direction.                                 |                   |      |        |
| <i>:ASYNchronous</i>           | Path to configure asynchronous Trigger Link:     |                   |      |        |
| <i>:ILINe &lt;NRf&gt;</i>      | Select input line (1 to 6).                      | 2                 |      |        |
| <i>:ILINe?</i>                 | Query input line.                                |                   |      |        |
| <i>:OLINe &lt;NRf&gt;</i>      | Select output line (1 to 6).                     | 1                 |      |        |
| <i>:OLINe?</i>                 | Query output line.                               |                   |      |        |
| <i>:SSYNchronous</i>           | Path to configure semi-synchronous Trigger Link: |                   |      |        |
| <i>:LINE &lt;NRf&gt;</i>       | Select trigger line (1 to 6).                    | 1                 |      |        |
| <i>:LINE?</i>                  | Query trigger line.                              |                   |      |        |

Notes:

- Defaults for continuous initiation:  
*:SYSTem:PRESet* enables continuous initiation  
*\*RST* disables continuous initiation
- TLINK and RTCLock (Arm Layer 1) are non-SCPI parameters for the *:SOURce* command. The command (*:SOURce*), and all the other parameters are SCPI confirmed.
- Defaults for count (Arm Layer 2 and Trigger Layer):  
*:SYSTem:PRESet* sets the count to INF (infinite).  
*\*RST* sets the count to 1.



**Table 3-16***UNIT command summary*

| <b>Command</b>                                                                                                                                                   | <b>Description</b>                                                                                                                                                                                                                                                                                                                                                                                        | <b>Default parameter</b>      | <b>SCPI</b> |
|------------------------------------------------------------------------------------------------------------------------------------------------------------------|-----------------------------------------------------------------------------------------------------------------------------------------------------------------------------------------------------------------------------------------------------------------------------------------------------------------------------------------------------------------------------------------------------------|-------------------------------|-------------|
| :UNIT<br>:TEMPerature <name><br>:TEMPerature?<br>:VOLTage<br>:AC <name><br>:DB<br>:REFerence <n><br>:REFerence?<br>:DBM<br>:IMPedance <n><br>:IMPedance?<br>:AC? | Select temperature measurement units (C, CEL, F, FAR or K).<br>Query temperature units.<br>Path to configure ACV units.<br>Select ACV measurement units (V, DB or DBM).<br>Path to set DB reference voltage.<br>Specify reference in volts.<br>Query DB reference.<br>Path to set DBM reference impedance.<br>Specify reference impedance (1-9999).<br>Query DBM reference impedance.<br>Query ACV units. | C<br><br>V<br><br>1<br><br>75 | √<br>√      |

## 3.12 Calculate subsystems

The commands in this subsystem are used to configure and control the three Calculate subsystems and are summarized in Table 3-4.

### 3.12.1 :CALCulate[1]

This subsystem is used to configure and control the Polynomial and Percent math calculations. Detailed information on math calculations is provided in paragraph 2.10.

#### :FORMat <name>

:CALCulate[1]:FORMat <name> Specify CALC 1 format

#### Parameters

|          |            |                                    |
|----------|------------|------------------------------------|
| <name> = | NONE       | No calculation                     |
|          | POLynomial | Polynomial math calculation        |
|          | PERCent    | Percent math calculation           |
|          | PDEViation | Percent deviation math calculation |

#### Query

:FORMat? Query programmed math format

#### Description

This command is used to specify the format for the CALC 1 math calculation. With NONE selected, no CALC 1 calculation is performed. With one of the other formats selected and CALC 1 enabled (see :STATe), the result of the calculation is displayed. The calculated reading is refreshed every time the instrument takes a reading.

#### Program fragment

```
PRINT #1, "output 16; :calc:form perc; form?" ' Select percent and query
 ' format
PRINT #1, "enter 16" ' Get response message from
 ' 2002
```

#### :KMATh commands

##### :MA0Factor <NRf>

:CALCulate[1]:KMATh:MA0Factor <NRf> Specify "a0" factor

#### Parameters

<NRf> = -9.999999e30 to +9.999999e30

#### Query

:MA0Factor Query "a0" factor

#### Description

This command is used to define the "a0" factor for the polynomial calculation.

#### Program fragment

```
PRINT #1, "output 16; :calc:kmat:ma0f 6; ma0f?" ' Set "a0" and query.
PRINT #1, "enter 16" ' Get response from 2002
```

##### :MA1Factor <NRf>

:CALCulate[1]:KMATh:MA1Factor <NRf> Specify "a1" factor

#### Parameters

<NRf> = -9.999999e20 to +9.999999e20

#### Query

:MA1Factor Query "a1" factor

|                         |                                                                                                                                                              |                                  |
|-------------------------|--------------------------------------------------------------------------------------------------------------------------------------------------------------|----------------------------------|
| <b>Description</b>      | This command is used to specify the “a1” factor for the polynomial calculation.                                                                              |                                  |
| <b>Program fragment</b> | PRINT #1, "output 16; :calc:kmat:ma1f 4; ma1f?"                                                                                                              | ' Set "a1" and query.            |
|                         | PRINT #1, "enter 16"                                                                                                                                         | ' Get response from 2002         |
|                         | <b>:MA2Factor &lt;NRf&gt;</b>                                                                                                                                |                                  |
|                         | :CALCulate[1]:KMATH:MA2Factor <NRf> Specify “a2” factor                                                                                                      |                                  |
| <b>Parameters</b>       | <NRf> = -9.999e20 to +9.999e20                                                                                                                               |                                  |
| <b>Query</b>            | :MA2Factor Query “a2” factor                                                                                                                                 |                                  |
| <b>Description</b>      | This command is used to specify the “a2” factor for the polynomial calculation.                                                                              |                                  |
| <b>Program fragment</b> | PRINT #1, "output 16; :calc:kmat:ma2f 6; ma0f?"                                                                                                              | ' Set "a2" and query.            |
|                         | PRINT #1, "enter 16"                                                                                                                                         | ' Get response from 2002         |
|                         | <b>:PERCent &lt;NRf&gt;</b>                                                                                                                                  |                                  |
|                         | :CALCulate[1]:KMATH:PERCent <NRf> Specify Percent target value                                                                                               |                                  |
| <b>Parameters</b>       | <NRf> = -9.999999e35 to +9.999999e35 Specify target value for Percent calculation.                                                                           |                                  |
| <b>Query</b>            | :PERCent? Query Percent target value                                                                                                                         |                                  |
| <b>Description</b>      | This command is used to specify the target value for the Percent calculation.                                                                                |                                  |
| <b>Program fragment</b> | PRINT #1, "output 16; :calc:kmat:perc 10; perc?"                                                                                                             | ' Set target to 10% and query    |
|                         | PRINT #1, "enter 16"                                                                                                                                         | ' Get response message from 2002 |
|                         | <b>:STATe &lt;b&gt;</b>                                                                                                                                      |                                  |
|                         | :CALCulate[1]:STATe <b> Control CALC 1                                                                                                                       |                                  |
| <b>Parameters</b>       | <b> = 0 or OFF Disable CALC 1 calculation<br>1 or ON Enable CALC 1 calculation                                                                               |                                  |
| <b>Query</b>            | :STATe? Query state (on or off) of CALC 1                                                                                                                    |                                  |
| <b>Description</b>      | This command is used to enable or disable the CALC 1 calculation. When enabled, each instrument reading will reflect the selected calculation (see :FORMat). |                                  |
| <b>Program fragment</b> | PRINT #1, "output 16; :calc:stat on;stat?"                                                                                                                   | ' Enable CALC1 and query         |
|                         | PRINT #1, "enter 16"                                                                                                                                         | ' Get response message from 2002 |
|                         | <b>:DATA commands</b>                                                                                                                                        |                                  |
|                         | <b>[:LATest]?</b>                                                                                                                                            |                                  |
|                         | :CALCulate[1]:DATA[:LATest]? Read CALC 1 result                                                                                                              |                                  |
| <b>Description</b>      | This query command is used to read the result of the CALC 1 calculation. If CALC 1 is disabled or NONE is selected, the “raw” reading will instead be read.  |                                  |

**Program fragment**

```
PRINT #1, "output 16; :calc:data?" ' Query result of CALC1
PRINT #1, "enter 16" ' Get response message from 2002
```

**:FRESH?**

```
:CALCulate[1]:DATA:FRESH? Recalculate CALC 1
```

**Description**

This query command is used to return a new (fresh) math result of CALC1. This command will not request the same result twice. If a new reading is triggered, this command will wait until the math result is available. When CALC1 is disabled, there is no difference between SENS:-DATA:FRESH? and CALC:DATA:FRESH?.

**Program fragment**

```
PRINT #1, "output 16; :calc:data:fresh?" ' Query new result of CALC1
PRINT #1, "enter 16" ' Get response from 2002
```

**:IMMEDIATE**

```
:CALCulate[1]:IMMEDIATE Recalculate CALC 1
```

**Query**

```
:IMMEDIATE? Perform calculation and read result (equivalent to :CALCulate[1]:IMMEDIATE;
DATA?)
```

**Description**

When you change the math calculation, the next instrument reading reflects the new calculation (assuming CALC 1 math is enabled). If the instrument is not in a continuous measurement mode (i.e. waiting for a trigger), the displayed reading will not update to reflect the new calculation until the next reading conversion occurs.

This action command allows you to reprocess the current input data to reflect a new calculation. For example, assume the instrument is in a non-continuous measurement mode and requires a manual trigger to cause the next reading conversion. Changing the calculation will not affect the currently displayed reading. However, sending the :IMMEDIATE command reprocesses that displayed reading to reflect the new calculation. Note that sending the :IMMEDIATE command does not initiate a reading conversion.

An alternate way to perform the calculation and read the result is by using the query form of the command (:IMMEDIATE?). When this command is sent, the calculation is performed and the result is queried.

**Program fragment**

```
PRINT #1, "output 16; :syst:pres?" ' Select defaults
PRINT #1, "output 16; :trig:sour bus" ' Place 2002 in one-shot measure mode
SLEEP 3 ' Wait three seconds
PRINT #1, "output 16; :calc:form pol" ' Select polynomial math calculation
PRINT #1, "output 16; :calc:kmat:ma0f 50" ' Set "a0" to 50
PRINT #1, "output 16; :calc:stat on" ' Enable MATH calculation
SLEEP 3 ' Wait three seconds
PRINT #1, "output 16; :cal:imm" ' Perform calculation (adds 50 to
 reading)
```

**3.12.2****:CALCulate2**

This Calculate subsystem is used to configure and control CALC 2 operations on readings stored in the buffer.

**:FORMat <name>**

:CALCulate2:FORMat &lt;name&gt; Specify CALC 2 format

**Parameters**

<name> = MEAN Mean value of readings in buffer  
 SDEV Standard deviation of readings in buffer  
 MAX Largest reading in buffer  
 MIN Lowest reading in buffer  
 PKPK Peak-to-peak value of readings in buffer  
 NONE No calculation

**Query**

:FORMat? Query programmed math format

**Description**

This command is used to specify the format for the CALC 2 math calculation. The calculation operations for CALC 2 use data stored in the buffer.

With NONE selected, no CALC 2 calculation will be performed. With one of the other formats selected and CALC 2 enabled (see :STATe), the calculation is performed every time the :IMMe-diate or :IMMediate? command is executed.

Details on MEAN, SDEV, MAX and MIN are provided in paragraph 2.8.4.

PKPK = MAX - MIN

where: MAX is the largest reading in the buffer  
 MIN is the lowest reading in the buffer

**Program fragment**

```
PRINT #1, "output 16; :calc2:form max; form?" ' Select MAX format and query
PRINT #1, "enter 16" ' Get response message from 2002
```

**:STATe <b>**

:CALCulate2:STATe &lt;b&gt; Control CALC 2

**Parameters**

<b> = 0 or OFF Disable CALC 2 calculation  
 1 or ON Enable CALC 2 calculation

**Query**

:STATe? Query state (on or off) of CALC 2

**Description**

This command is used to enable or disable the CALC 2 calculation. When enabled, the selected CALC 2 format will be calculated when the :IMMediate or :IMMediate? command is executed.

**Program fragment**

```
PRINT #1, "output 16; :calc2:stat on; stat?" ' Enable CALC 2 and query
PRINT #1, "enter 16" ' Get response message from 2002
```

**:IMMediate**

:CALCulate2:IMMediate Perform CALC 2

**Query**

:IMMediate? Perform calculation and read result (equivalent to :CALCulate2:IMMediate; DATA?)

**Description**

The :IMMediate command is used to perform the selected CALC 2 operation on the readings in the buffer (assuming CALC 2 is enabled; see :STATe). After performing the calculation, the result can be read by using the :CALCulate2:DATA? query command.

An alternate way to perform the calculation and read the result is by using the query form of the command (:IMMediate?). When this command is sent, the calculation is performed and the result is queried.

**Program fragment**

This example assumes that there are readings stored in the buffer and CALC 2 is enabled:

```
PRINT #1, "output 16; :calc2:form max" ' Select MAX format
PRINT #1, "output 16; :calc2:imm?" ' Perform math and query result
PRINT #1, "enter 16" ' Get response message from 2002
```

**:DATA?**

```
:CALCulate2:DATA? Read CALC 2 result
```

**Description**

This query command is used to read the result of the CALC 2 operation. If CALC 2 is disabled or NONE is selected, the “raw” reading will instead be read.

Note that this command does not initiate a calculation. This command is used to simply read the result of the last calculation.

**Program fragment**

```
PRINT #1, "output 16; :calc2:data?" ' Query CALC2 reading
PRINT #1, "enter 16" ' Get response message from 2002
```

**3.12.3****:CALCulate3**

This Calculate subsystem is used to configure and control the limit tests (LIMIT 1 test and LIMIT 2 test). See paragraph 2.12.5 for details on limit tests.

**[:DATA] <n>**

```
:CALCulate3:LIMit[1]:UPPer[:DATA] <n> Specify upper LIMIT 1
:CALCulate3:LIMit[1]:LOWer[:DATA] <n> Specify lower LIMIT 1
:CALCulate3:LIMit2:UPPer[:DATA] <n> Specify upper LIMIT 2
:CALCulate3:LIMit2:LOWer[:DATA] <n> Specify lower LIMIT 2
```

**Parameters**

```
<n> = -9.999999e35 to +9.999999e35 Specify limit value
Default Set specified upper limit to 1
 Set specified lower limit to -1
Minimum Set specified limit to -9.999999e35
Maximum Set specified limit to +9.999999e35
```

**Query**

```
:UPPer? Query specified upper limit
:UPPer? Default Query *RST default upper limit
:UPPer? Minimum Query lowest allowable upper limit
:UPPer? Maximum Query largest allowable upper limit

:LOWer? Query specified lower limit
:LOWer? Default Query *RST default lower limit
:LOWer? Minimum Query lowest allowable lower limit
:LOWer? Maximum Query largest allowable lower limit
```

**Description**

These commands are used to set the upper and lower limits for LIMIT 1 and LIMIT 2. The actual limit depends on which measurement function is currently selected. For example, a limit value of 1 is 1V for the volts functions (DCV or ACV), 1A for the current functions (DCI or

ACI),  $1\Omega$  on the ohms functions ( $\Omega 2$  or  $\Omega 4$ ), and  $1^\circ$  (C, F or K) for the temperature function (TEMP). A limit value is not range sensitive. A limit of 2 for DCV is 2V on all measurement ranges. Note that limit tests cannot be performed on frequency (FREQ) measurements.

**Program fragment**

```
PRINT #1, "output 16; :calc3:lim:upp 10; upp?" ' Set upper LIMIT 1 and query
PRINT #1, "enter 16" ' Get response message from
 2002
```

**:SOURce <NRf>**

```
:CALCulate3:LIMit[1]:UPPer:SOURce <NRf> Specify pattern; upper LIMIT 1 failure
:CALCulate3:LIMit[1]:LOWer:SOURce <NRf> Specify pattern; lower LIMIT 1 failure
:CALCulate3:LIMit2:UPPer:SOURce <NRf> Specify pattern; upper LIMIT 2 failure
:CALCulate3:LIMit2:LOWer:SOURce <NRf> Specify pattern; lower LIMIT 2 failure
```

**Parameters**

<NRf> = 0 to 15 Specify digital pattern for output port

**Query**

:SOURce? Query source value for specified limit

**Description**

These commands are used to specify which line(s) of the Digital Output Port will go true when a limit test failure occurs. The first failure in the test sequence determines the digital output pattern. Subsequent failures in the test sequence will not change the digital output pattern on the output port.

Each output line is assigned a decimal weight as follows:

| Digital Output | Decimal Weight |
|----------------|----------------|
| Line #1        | 1              |
| Line #2        | 2              |
| Line #3        | 4              |
| Line #4        | 8              |

The parameter value for the digital pattern is determined by adding the decimal weights of the desired output lines. For example, if you want output lines #2 and #3 to go true when the upper limit of LIMIT 1 is the first failure in the test sequence, use a parameter value of 6 (2+4).

The actual true state (high or low) of each Digital Output line depends on its programmed polarity. Polarity is programmed from the OUTPut subsystem (see paragraph 3.16).

Note that when the binning strobe is enabled (see :BSTRobe command path), output line #4 is not considered to be part of the digital output pattern. The binning strobe uses line #4. With the binning strobe enabled, parameters 8 through 15 are treated the same as parameters 0 through 7.

**Program fragment**

```
PRINT #1, "output 16; :calc3:lim:upp:sour 4; sour?" ' Select line #4 and query
PRINT #1, "enter 16" ' Get response message
 from 2002
```

**:STATe <b>**

```
:CALCulate3:LIMit[1]:STATe Control LIMIT 1 test
:CALCulate3:LIMit2:STATe Control LIMIT 2 test
```

**Parameters**

<b> = 1 or ON Enable specified limit test  
0 or OFF Disable specified limit test

**Query**

:STATe? Query state of specified limit test

**Description**

These commands are used to enable or disable LIMIT 1 and LIMIT 2 tests. When enabled, the test sequence for limits will be performed every time the instrument performs a measurement. Testing is performed in the following sequence: Low Limit 1, High Limit 1, Low Limit 2 and High Limit 2. Any limit test (LIMIT 1 or LIMIT 2) not enabled is simply not performed.

Note that when a limit test (LIMIT 1 or LIMIT 2) is enabled, the digital output port cannot be controlled from the Source Subsystem.

A fail indication (see :FAIL?) for LIMIT 1 or LIMIT 2 is cleared when the respective limit test is disabled.

**Program fragment**

```
PRINT #1, "output 16; :calc3:lim:stat on; stat?" ' Enable LIMIT 1 test and
 ' query
PRINT #1, "enter 16" ' Get response message from
2002
```

**:FAIL?**

```
:CALCulate3:LIMit[1]:FAIL? Read LIMIT 1 test results
:CALCulate3:LIMit2:FAIL? Read LIMIT 2 test results
```

**Description**

These commands are used to read the results of LIMIT 1 and LIMIT 2 tests:

```
0 = Limit test passed
1 = Limit test failed
```

The response message (0 or 1) only tells you if a limit test has passed or failed. It does not tell you which limit (upper or lower) has failed. To determine which limit has failed, you will have to read the Measurement Event Register (see paragraph 3.20.1).

Reading the results of a limit test does not clear the fail indication of the test. A failure can be cleared by using a :CLEAR command, or by disabling the test (:STATe OFF).

**Program fragment**

```
PRINT #1, "output 16; :calc3:lim:fail?" ' Query result of LIMIT 1 test
PRINT #1, "enter 16" ' Get response message from 2002
```

**:CLEAR commands****[:IMMediate]**

```
:CALCulate3:LIMit[1]:CLEAR[:IMMediate] Clear LIMIT 1 test failure
:CALCulate3:LIMit2:CLEAR[:IMMediate] Clear LIMIT 2 test failure
```

**Description**

These action commands are used to clear the fail indication of LIMIT 1 and LIMIT 2 tests. Note that a failure is also cleared when the limit test is disabled (:STATe OFF).

**Program fragment**

```
PRINT #1, "output 16; :calc3:lim:cle" ! Clear fail condition of LIMIT 1 test.
```

**:AUTO <b>**

```
:CALCulate3:LIMit[1]:CLEAR:AUTO Control auto-clear; LIMIT 1
:CALCulate3:LIMit2:CLEAR:AUTO Control auto-clear; LIMIT 2
```

**Parameters**

```
 = 1 or ON Enable auto-clear for limit failure
 0 or OFF Disable auto-clear for limit failure
```

**Query**

```
:AUTO? Query state of auto clear
```



**Description**

With auto-clear enabled, the fail indication of a limit test clears when instrument operation enters the idle state. With auto-clear disabled, the fail indication will remain until it is cleared by the :CLear[:IMMediate] command.

**Program fragment**

```
PRINT #1, "output 16; :calc3:lim:cle:auto on; auto?" ' Enable auto-clear and query
PRINT #1, "enter 16" ' Get response message from 2002
```

**:PASS:SOURce <NRf>**

:CALCulate3:PASS:SOURce <NRf> Specify "pass" pattern

**Parameters**

<NRf> = 0 to 15 Specify digital pattern for output port

**Query**

:SOURce Query programmed source value

**Description**

This command is used to specify which line(s) of the Digital Output Port will go true when there are no failures in the limit tests.

Each output line is assigned a decimal weight as follows:

| Digital Output | Decimal Weight |
|----------------|----------------|
| Line #1        | 1              |
| Line #2        | 2              |
| Line #3        | 4              |
| Line #4        | 8              |

The parameter value for the digital pattern is determined by adding the decimal weights of the desired output lines. For example, if you want output lines #2 and #3 to go true when all enabled limit tests pass, use a parameter value of 6 (2+4).

The actual true state (high or low) of each digital output line depends on its programmed polarity. Polarity is programmed from the OUTPut Subsystem (see paragraph 3.16).

Note that when the binning strobe is enabled (see :BSTRobe command path), output line #4 is not considered to be part of the digital output pattern. The binning strobe uses line #4. With the strobe enabled, parameter values 8 through 15 are treated the same as parameters 0 through 7.

**Program fragment**

```
PRINT #1, "output 16; :calc3:pass:sour 3; sour?" ' Select line #3
PRINT #1, "enter 16" ' Get response message from 2002
```

**:CLIMitsFAIL?**

:CALCulate3:CLIMits:FAIL? Read composite result of limit tests

This query command is used to obtain the composite result of the LIMIT 1 and LIMIT 2 tests. The composite result is the logical OR'ed summary of LIMIT 1 and LIMIT 2:

1 = One or both tests have failed.  
0 = Both tests have passed.

In the event of a failure (1), you can determine which test(s) has failed by using the fail command of each limit (:LIMit1:FAIL? and :LIMit2:FAIL?).

This command (like the other fail commands) does not clear the fail indication for LIMIT 1 or LIMIT 2.

**Program fragment**

```
PRINT #1, "output 16; :calc3:clim:fail?" ' Query composite results of tests
PRINT #1, "enter 16" ' Get response message from 2002
```

**:BSTRobe:STATE <b>**

```
:CALCulate3:BSTRobe:STATE Control binning strobe
```

**Parameters**

```
 = 1 or ON Enable binning strobe
 0 or OFF Disable binning strobe
```

**Query**

```
:STATE? Query state of binning strobe
```

**Description**

This command is used to enable or disable the strobe for the binning operation. When enabled, digital output line #4 is used for the binning strobe pulse. After the appropriate digital pattern is placed on the other three lines of the output port, the >10µsec strobe pulse is asserted on line #4. The strobe is used to “inform” your external binning circuit that the output port (lines 1, 2 and 3) is ready to be read.

**Program fragment**

```
PRINT #1, "output 16; :calc3:bstr:stat on; stat?" ' Enable strobe and query
PRINT #1, "enter 16" ' Get response message from
 2002
```

**:IMMediate**

```
:CALCulate3:IMMediate Perform CALC 3
```

**Description**

When you change the configuration of the limit test, the next reading is evaluated according to that new test configuration. If the instrument is not in a continuous measurement mode (e.g., waiting for a manual trigger), the test will not be performed until the next reading conversion occurs.

This action command allows you to re-process the current input data to test new limits. For example, assume the instrument is in a non-continuous measurement mode and requires a manual trigger to cause the next reading conversion. Changing the test limits will not affect the last test result. However, sending the :IMMediate command reprocesses the data and evaluates the reading according to the new test limits. Note that sending the :IMMediate command does not initiate a reading conversion.

**Program fragment**

```
PRINT #1, "output 16; :trig:sour bus" ' Place 2002 in one-shot mode
SLEEP 3 ' Wait three seconds
PRINT #1, "output 16; :calc3:imm" ' Re-perform limit test
```

### 3.13 :DISPlay subsystem

The display subsystem controls the display of the Model 2002 and is summarized in Table 3-5.

#### :TEXT commands

##### :DATA <a>

:DISPlay[:WINDow[1]]:TEXT:DATA <a>                    Define message for top display  
:DISPlay:WINDow2:TEXT:DATA <a>                    Define message for bottom display

#### Parameters

<a> = ASCII characters for message

Types:    String                    'aa...a' or "aa...a"  
          Indefinite Block        #0aa...a  
          Definite Block          #XYaa...a

where;    Y = number of characters in message:  
          Up to 20 for top display  
          Up to 32 for bottom display  
          X = number of digits that make up Y (1 or 2)

#### Query

:DATA?    Query the defined text message

#### Description

These commands define text messages for display. A message can be as long as 20 characters for the top display, and up to 32 characters for the bottom display. A space is counted as a character. Excess message characters results in an error.

An indefinite block message must be the only command in the program message or the last command in the program message. If you include a command after an indefinite block message (on the same line), it will be treated as part of the message and is displayed instead of executed.

#### Program fragment

```
PRINT #1, "output 16; :disp:text:data ' Model 2002';data?" ' Define and query
 message
PRINT #1, "enter 16" ' Get response mes-
 sage from 2002
```

##### :STATe <b>

:DISPlay[:WINDow[1]]:TEXT:STATe <b>                    Control (on/off) message; top display  
:DISPlay:WINDow2:TEXT:STATe <b>                    Control (on/off) message; bottom display

#### Parameters

<b> = 0 or OFF    Disable text message for specified display  
     = 1 or ON    Enable text message for specified display

#### Query

:STATe?    Query state of message mode for specified display

#### Description

These commands enable and disable the text message modes. When enabled, a defined message is displayed. When disabled, the message is removed from the display.

A user defined text message remains displayed only as long as the instrument is in remote. Taking the instrument out of remote (by pressing the LOCAL key or sending LOCAL 16), cancels the message and disables the text message mode.

**Program fragment**

```
PRINT #1, "output 16; :disp:text:stat on; stat?" ' Enable and query message
mode
PRINT #1, "enter 16" ' Get response message from
2002
```

**:DATA?**

```
:DISPlay[:WINDow[1]]:DATA? Read top display
:DISPlay:WINDow2:DATA? Read bottom display
```

**Description**

These query commands are used to read what is currently being displayed on the top and bottom displays. After sending one of these commands and addressing the Model 2002 to talk, the displayed data (message or reading) will be sent to the computer.

**Program fragment**

```
PRINT #1, "output 16; :disp:data?" ' Query displayed data
PRINT #1, "enter 16" ' Get response message from 2002
```

**:CNDisplay**

```
:DISPlay:CNDisplay Clear (cancel) NEXT display
```

**Description**

This action command is used to clear the bottom display of NEXT (or PREV) messages and cancel the operations associated with them. This command has no effect on any other message types.

**Program fragment**

This example assumes that a NEXT operation is currently being displayed.

```
PRINT #1, "output 16; :cnd" ' Clear NEXT display
```

**:SMESsage <b>**

```
:DISPlay:SMESsage Control status message
```

**Parameters**

```
 = 0 or OFF Disable status messages
 = 1 or ON Enable status messages
```

**Query**

```
:SMESsage? Query state of status message mode
```

**Description**

This command is used to enable/disable the status message mode. The status message mode is a diagnostic tool that provides real-time messages that relate to the current operating state of the instrument. Table 2-4 lists the status messages.

**Program fragment**

```
PRINT #1, "output 16; :disp:smes on; smes?" ' Enable and query status message
mode
PRINT #1, "enter 16" ' Get response message from 2002
```

**:ENABLE <b>**

```
:DISPlay:ENABLE Control display circuitry
```

**Parameters**

```
 = 0 or OFF Disable display circuitry
 = 1 or ON Enable display circuitry
```

**Query**

```
:ENABLE? Query state of display
```

**Description**

This command is used to enable and disable the front panel display circuitry. When disabled, the instrument operates at a higher speed. While disabled, the display is frozen with the following message:

```
FRONT PANEL DISABLED
Press LOCAL to resume.
```

As reported by the message, all front panel controls (except LOCAL) are disabled. Normal display operation can be resumed by using the :ENABLE command to enable the display or by putting the Model 2002 into local.

**Program fragment**

```
PRINT #1, "output 16; :disp:enab off; enab?" ' Disable and query display
 circuitry
PRINT #1, "enter 16" ' Get response message from 2002
```

### 3.14 :FORMat subsystem

The commands for this subsystem are used to select the data format for transferring instrument readings over the bus. The BORDER command and DATA command affect readings transferred from the buffer ONLY. (i.e. SENSE: DATA? or CALC:DATA? is always be sent in ASCII.) These commands are summarized in Table 3-6.

#### **[[:DATA] <type>[,length]**

:FORMat[:DATA] <type>[,<length>] Specify data format

#### **Parameters**

|                     |         |                                 |
|---------------------|---------|---------------------------------|
| <type>[,<length>] = | ASCii   | ASCII format                    |
|                     | REAL,32 | IEEE754 single precision format |
|                     | REAL,64 | IEEE754 double precision format |
|                     | SREal   | IEEE754 single precision format |
|                     | DREal   | IEEE754 double precision format |

#### NOTES:

1. When using the ASCii, SREal or DREal parameter, a <length> parameter is not required.
2. If you do not use a <length> parameter with the REAL parameter, the <length> defaults to 32 (single precision format).

#### **Query**

[[:DATA]? Query data format

#### **Description**

This command is used to select the data format for transferring readings over the bus. For every reading conversion, the data string sent over the bus contains the elements specified by the :ELEMents command. The specified elements are sent in a particular order.

The ASCII data format is in a direct readable form for the operator. Most BASIC languages easily convert ASCII mantissa and exponent to other formats. However, some speed is compromised to accommodate the conversion. Figure 3-18 shows the ASCII format that includes all the data elements.

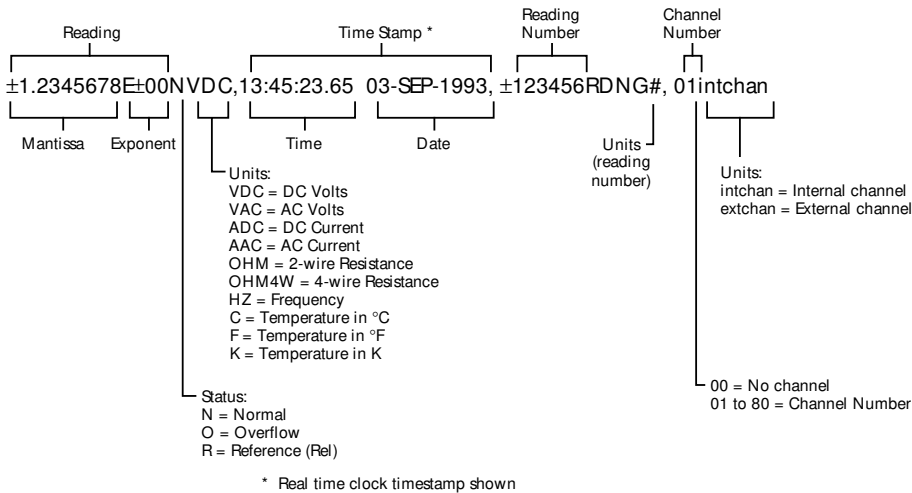
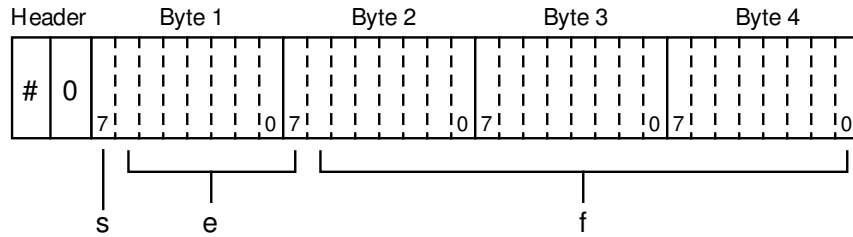

Figure 3-18  
ASCII data format

REAL,32 or SREal will select the binary IEEE754 single precision data format. Figure 3-19 shows the normal byte order format for each data element. For example, if three valid elements are specified, the data string for each reading conversion is made up of three 32-bit data blocks. Note that the data string for each reading conversion is preceded by a 2-byte header that is the binary equivalent of an ASCII # sign and 0.



s = sign bit (0 = positive, 1 = negative)

e = exponent bits (8)

f = fraction bits (23)

Normal byte order shown. For swapped byte order, bytes sent in reverse order: Header, Byte 4, Byte 3, Byte 2, Byte 1.

The Header is only sent once for each measurement conversion.

**Figure 3-19**

*IEEE754 single precision data format (32 data bits)*

REAL,64 or DREal selects the binary IEEE754 double precision data format and is shown in Figure 3-20 (normal byte order shown). This format is similar to the single precision format except that it is 64 bits long.

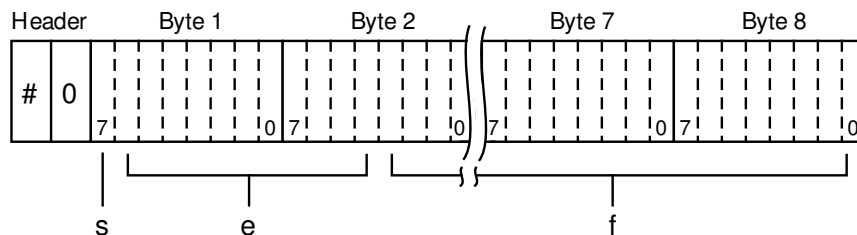

Bytes 3, 4, 5, and 6 not shown.

s = sign bit (0 = positive, 1 = negative)

e = exponent bits (11)

f = fraction bits (52)

Normal byte order shown. For swapped byte order, bytes sent in reverse order: Header, Byte 8, Byte 7 .... Byte 1.

The Header is only sent once for each measurement conversion.

**Figure 3-20**

*IEEE754 double precision data format (64 data bits)*

### Program fragment

```
PRINT #1, "output 16; :form sre; form?" ' Select SREal format and query
PRINT #1, "enter 16" ' Get response message from 2002
```

### **:ELEMents <item list>**

:FORMat:ELEMents <item list> Specify data elements for data string

#### Parameters

|              |           |                                 |
|--------------|-----------|---------------------------------|
| <item list>: | READing   | Includes reading in data string |
|              | CHANnel   | Includes channel number         |
|              | RNUMber   | Includes reading number         |
|              | UNITs     | Includes units                  |
|              | TIMEstamp | Includes time stamp             |
|              | STATus    | Includes status of reading      |

NOTE: Each item in the list must be separated by a comma (,).

#### Query

:ELEMents? Query elements in data string

#### Description

This command is used to specify the elements to be included in the data string for each measurement conversion. You can specify from one to all six elements. Each element in the list must be separated by a comma (,). These elements, shown in Figure 3-18, are explained as follows:

**READing:** Instrument reading. The resolution of this reading tracks the display resolution of the instrument. An overflow reading reads as +9.9E37.

**CHANnel:** Corresponds the instrument reading to the channel number of a switching card. If not scanning, the channel number is 00.



**RNUMBER:** The instrument keeps track of the number of readings it has performed. This reading counter starts at zero when the instrument is turned on or when `:SYSTEM:RNUMBER:RESET` is sent over the bus. When a reading is sent over the bus (i.e. `:FETCH?`), the `RNUMBER` element indicates the reading number. The instrument also keeps track of the number of readings it has stored in the buffer. When buffer readings are sent over the bus (`:TRACE:DATA?`), each reading number is referenced to the first reading, which is #0, stored in the buffer. If using Pre-trigger to store readings, the pre-trigger readings are assigned negative numbers.

**UNITS:** This element attaches the function unit to the reading, the time unit (sec) to the timestamp, and the channel unit (internal or external) to the channel number. An internal channel refers to an internally installed switching card (such as the Model 2001-SCAN) channel, while an external channel refers to the channel for an external switch system. This element is not available for the binary formats.

**TIMESTAMP:** A timestamp is available to reference each reading to a point in time. There are two basic types of timestamps; real-time timestamp and relative time timestamp. The real-time timestamp provides the time (24-hour clock format) and date for each reading sent over the bus. The relative timestamp operates as a timer that starts at zero seconds when the instrument is turned on or when the relative timestamp is reset (`:SYSTEM:TSTAMP:RELATIVE:RESET`). The timestamp for each reading sent over the bus is referenced, in seconds, to the start time. After 99,999.999999 seconds, the timer resets back to zero and starts over.

Timestamp is also available for buffer readings. Timestamp can be referenced to the first reading stored in the buffer (absolute format) which is timestamped at 0 seconds, or can provide the time between each reading (delta format). The `:TRACE:TSTAMP:FORMAT` command is used to select the absolute or delta format. For the delta format, real-time timestamp is expressed as the days, hours, minutes and seconds between each reading, while the relative timestamp is expressed as seconds between each reading. When using the absolute format for the relative timestamp, any pre-trigger readings will have a negative timestamp.

**STATUS:** This element indicates if the reading is normal (N), overflowed (O) or referenced (R) to another value. This element is not available for the binary formats.

The ASCII format shown in Figure 3-18 shows the byte order of the data string. Keep in mind that the byte order can only be reversed for the binary formats.

When using this command to add an element, you must include all elements that you want in the format. For example, if the reading is already specified and you want to add the time-stamp, you must include the `READING` parameter.

```
:form:elem time, read
```

Data elements for the item list can be listed in any order, but are always sent in the order shown in Figure 3-18.

### Program fragment

```
PRINT #1, "output 16; :form:elem read, stat, unit; elem?" ' Specify elements
PRINT #1, "enter 16" ' Get response message from 2002
```

### **:BORDER** <name>

```
:FORMat:BORDER <name> Specify binary byte order
```

### Parameters

```
<name> = NORMAL Normal byte order for binary formats
 SWAPPED Reverse byte order for binary formats
```

|                         |                                                                                                                                                                                                                                                                                                                                                                                                                                                                                                                                                                                                                                                                                                                                                                                                                                                                                                                                                                                                                                                |        |        |                    |        |                    |        |        |     |        |                    |        |        |        |        |                    |        |        |     |        |                    |
|-------------------------|------------------------------------------------------------------------------------------------------------------------------------------------------------------------------------------------------------------------------------------------------------------------------------------------------------------------------------------------------------------------------------------------------------------------------------------------------------------------------------------------------------------------------------------------------------------------------------------------------------------------------------------------------------------------------------------------------------------------------------------------------------------------------------------------------------------------------------------------------------------------------------------------------------------------------------------------------------------------------------------------------------------------------------------------|--------|--------|--------------------|--------|--------------------|--------|--------|-----|--------|--------------------|--------|--------|--------|--------|--------------------|--------|--------|-----|--------|--------------------|
| <b>Query</b>            | :BORDER? Query byte order                                                                                                                                                                                                                                                                                                                                                                                                                                                                                                                                                                                                                                                                                                                                                                                                                                                                                                                                                                                                                      |        |        |                    |        |                    |        |        |     |        |                    |        |        |        |        |                    |        |        |     |        |                    |
| <b>Description</b>      | <p>This command is used to control the byte order for the IEEE754 binary formats. For normal byte order, the data format for each element is sent as follows:</p> <table border="0"> <tr> <td>Byte 1</td> <td>Byte 2</td> <td>Byte 3</td> <td>Byte 4</td> <td>(Single precision)</td> </tr> <tr> <td>Byte 1</td> <td>Byte 2</td> <td>•••</td> <td>Byte 8</td> <td>(Double precision)</td> </tr> </table> <p>For reverse byte order, the data format for each element is sent as follows:</p> <table border="0"> <tr> <td>Byte 4</td> <td>Byte 3</td> <td>Byte 2</td> <td>Byte 1</td> <td>(Single precision)</td> </tr> <tr> <td>Byte 8</td> <td>Byte 7</td> <td>•••</td> <td>Byte 1</td> <td>(Double precision)</td> </tr> </table> <p>The “#,0” Header is not affected by this command. The Header is always sent at the beginning of the data string for each measurement conversion.</p> <p>The ASCII data format can only be sent in the normal byte order. The SWAPped selection is simply ignored when the ASCII format is selected.</p> | Byte 1 | Byte 2 | Byte 3             | Byte 4 | (Single precision) | Byte 1 | Byte 2 | ••• | Byte 8 | (Double precision) | Byte 4 | Byte 3 | Byte 2 | Byte 1 | (Single precision) | Byte 8 | Byte 7 | ••• | Byte 1 | (Double precision) |
| Byte 1                  | Byte 2                                                                                                                                                                                                                                                                                                                                                                                                                                                                                                                                                                                                                                                                                                                                                                                                                                                                                                                                                                                                                                         | Byte 3 | Byte 4 | (Single precision) |        |                    |        |        |     |        |                    |        |        |        |        |                    |        |        |     |        |                    |
| Byte 1                  | Byte 2                                                                                                                                                                                                                                                                                                                                                                                                                                                                                                                                                                                                                                                                                                                                                                                                                                                                                                                                                                                                                                         | •••    | Byte 8 | (Double precision) |        |                    |        |        |     |        |                    |        |        |        |        |                    |        |        |     |        |                    |
| Byte 4                  | Byte 3                                                                                                                                                                                                                                                                                                                                                                                                                                                                                                                                                                                                                                                                                                                                                                                                                                                                                                                                                                                                                                         | Byte 2 | Byte 1 | (Single precision) |        |                    |        |        |     |        |                    |        |        |        |        |                    |        |        |     |        |                    |
| Byte 8                  | Byte 7                                                                                                                                                                                                                                                                                                                                                                                                                                                                                                                                                                                                                                                                                                                                                                                                                                                                                                                                                                                                                                         | •••    | Byte 1 | (Double precision) |        |                    |        |        |     |        |                    |        |        |        |        |                    |        |        |     |        |                    |
| <b>Program fragment</b> | <pre>PRINT #1, "output 16; :form:bord swap; bord?"      ' Reverse byte order PRINT #1, "enter 16"                               ' Get response message from 2002</pre>                                                                                                                                                                                                                                                                                                                                                                                                                                                                                                                                                                                                                                                                                                                                                                                                                                                                         |        |        |                    |        |                    |        |        |     |        |                    |        |        |        |        |                    |        |        |     |        |                    |
|                         | <p><b>:EXPonent &lt;name&gt;</b></p> <p>:FORMat:EXPonent &lt;name&gt; Set exponent format.</p>                                                                                                                                                                                                                                                                                                                                                                                                                                                                                                                                                                                                                                                                                                                                                                                                                                                                                                                                                 |        |        |                    |        |                    |        |        |     |        |                    |        |        |        |        |                    |        |        |     |        |                    |
| <b>Parameters</b>       | <p>&lt;name&gt; =   NORMal    Normal format<br/>             HPRecision   High-precision format</p>                                                                                                                                                                                                                                                                                                                                                                                                                                                                                                                                                                                                                                                                                                                                                                                                                                                                                                                                            |        |        |                    |        |                    |        |        |     |        |                    |        |        |        |        |                    |        |        |     |        |                    |
| <b>Query</b>            | :EXPonent? Query exponent format                                                                                                                                                                                                                                                                                                                                                                                                                                                                                                                                                                                                                                                                                                                                                                                                                                                                                                                                                                                                               |        |        |                    |        |                    |        |        |     |        |                    |        |        |        |        |                    |        |        |     |        |                    |
| <b>Description</b>      | <p>This command defines the exponent format. The default setting is NORMal, in which case the returned value is formatted according to the engineering units of the present range (for example, 0.0012341E+03 on the 2k, 20k, or 200k range). Choosing HPRecision selects the highest precision possible, so the above example would be returned as 1.2341234E+00 with three extra digits of precision.</p>                                                                                                                                                                                                                                                                                                                                                                                                                                                                                                                                                                                                                                    |        |        |                    |        |                    |        |        |     |        |                    |        |        |        |        |                    |        |        |     |        |                    |
| <b>Program fragment</b> | <pre>PRINT #1, "output 16; :form:exp hpr"              ' Set high precision.</pre>                                                                                                                                                                                                                                                                                                                                                                                                                                                                                                                                                                                                                                                                                                                                                                                                                                                                                                                                                             |        |        |                    |        |                    |        |        |     |        |                    |        |        |        |        |                    |        |        |     |        |                    |

### 3.15 :INPut subsystem

The :INPut subsystem is used for the Model 1801 Nanovolt Preamp. These commands are summarized in Table 3-7.

#### :PREamp Commands

The :PREamp commands are used to control the Model 1801 Nanovolt Preamp card. Refer to the Model 1801 instruction manual for detailed operating information.

#### :STATe <b>

:INPut:PREamp:STATe <b>      Enable or disable preamp

#### Parameters

<b> =    1 or ON      Enable preamp  
         0 or OFF     Disable preamp

#### Query

:STATe?    Query state of preamp

#### Description

With the Model 1801 installed in the option slot, this command is used to enable or disable preamp.

#### Program fragment

```
PRINT #1, "output 16; :inp:pre:stat on" ' Enable preamp
PRINT #1, "enter 16" ' Get response from 2002
```

#### :FILTer <name>

:INPut:PREamp:FILTer <name>      Select filter response

#### Parameters

<name> =    SLOW      Select slow filter response  
              MED        Select medium filter response  
              FAST        Select fast filter response

#### Query

:FILTer?    Query selected filter response

#### Description

This command is used to select the filter response for the preamp. Note that only the FAST response is available for the ACV and FREQ functions.

#### Program fragment

```
PRINT #1, "output 16; :inp:pre:filt fast" ' Select FAST filter response
PRINT #1, "enter 16" ' Get response from 2002
```

### 3.16 :OUTPut subsystem

The OUTPut subsystem is used to set polarities for the digital output port. Commands in this subsystem are summarized in Table 3-8.

#### **:LSENse <name>**

|                              |                         |
|------------------------------|-------------------------|
| :OUTPut:TTL[1]:LSENse <name> | Set polarity of line #1 |
| :OUTPut:TTL2:LSENse <name>   | Set polarity of line #2 |
| :OUTPut:TTL3:LSENse <name>   | Set polarity of line #3 |
| :OUTPut:TTL4:LSENse <name>   | Set polarity of line #4 |

#### **Parameters**

|          |       |                                                |
|----------|-------|------------------------------------------------|
| <name> = | AHIGH | Set polarity of specified line to active high. |
|          | ALOW  | Set polarity of specified line to active low.  |

#### **Query**

:LSENse? Query polarity of specified line

#### **Description**

These commands are used to set the polarity of the digital output lines. When set for active high (AHIGH) polarity, the specified output line is true (ON) when the output level is high. The output line is false (OFF) when the output level is low. When set for active low (ALOW) polarity, the output line is true (ON) when the output level is low. The output line is false (OFF) when the output level is high.

The logic levels (true or false) of the digital output lines are set from the SOURce Subsystem (see paragraph 3.19).

#### **Program fragment**

```
PRINT #1, "output 16; :outp:ttl:lsen allow; lsen?" ' Set line #1 to ALOW
PRINT #1, "enter 16" ' Get response message from
 2002
```

## 3.17 :ROUTe subsystem

The commands in this subsystem are used to configure and control switching and are summarized in Table 3-9.

### 3.17.1 :CLOSE <list>

:ROUTe:CLOSE <list> Close specified channel

#### Parameters

<list> = (@ chanlist) Specify channel to be closed

where; chanlist is the channel (1 to 10) to be closed

#### Query

:CLOSE? <list> Query specified channel.

#### Description

The :CLOSE <list> command is used to close a channel on the Model 2001-SCAN scanner card. Only one channel can be closed at a time. Thus, for this command, the chanlist must consist of only one channel. When this command is sent, any other closed channel will first open and then the specified channel will close.

The :CLOSE? <list> query command is used to determine the state (closed or not closed) of each channel specified by the list parameter. For this command, the chanlist can consist of multiple channels. The following examples demonstrate the various forms for expressing the channel list.

List = (@ 2) Single channel.  
 (@ 2,4,6) Multiple channels separated by commas (.).  
 (@ 1:10) Range of channels (1 through 10). Range limits separated by a colon (:).  
 (@ 1:5,7) Range entry and single entry separated by a comma.

After sending this query command and addressing the Model 2002 to talk, the values for the specified channels are sent to the computer. A value of "1" indicates that the channel is closed, and a "0" indicates that the channel is not closed.

#### Program fragment

```
PRINT #1, "output 16; :rout:clos (@ 10); clos? (@10)" ' Close and query chan-
 ' nel 10
PRINT #1, "enter 16" ' Get response message
 ' from 2002
```

### STATE?

:ROUTe:CLOSE:STATE? Query closed channel.

#### Description

This query command is used to determine which (if any) channel on the Model 2001 SCAN is closed. After sending this command and addressing the Model 2002 to talk, the channel list is sent to the computer.

#### Program fragment

```
PRINT #1, "output 16; :rout:clos:stat?" ' Query closed channel
PRINT #1, "enter 16" ' Get response message from 2002
```

### 3.17.2 :OPEN <list>

:ROUTe:OPEN <list>

#### Parameters

<list> = (@ chanlist) Specify channel to open  
 ALL Open all channels

where; chanlist = 1 to 10

**Query** :OPEN? <list> Query specified channel.

**Description**

The :OPEN <list> command is used to open a channel on the Model 2001-SCAN scanner card. Since only one channel can be closed, the chanlist for this command can only consist of one channel. An alternate way to open a closed channel is to simply use the ALL parameter. It opens whichever channel is closed.

The :OPEN? <list> query command is used to determine the state (opened or not opened) of each channel specified by the list parameter. For this command, the chanlist can consist of multiple channels. See the :CLOSE command for examples to express a chanlist.

After sending this query command and addressing the Model 2002 to talk, the values for the specified channels are sent to the computer. A value of "1" indicates that the channel is open, and a "0" indicates that the channel is not open.

**Program fragment**

```
PRINT #1, "output 16; :rout:clos(@ 5); open? (@ 1:10)" ' Close channel and
 query
PRINT #1, "enter 16" ' Get response message
 from 2002
```

**3.17.3**

**:OPEN:ALL**

:ROUte:OPEN:ALL Open closed channel

**Description**

This action command is used to open a closed channel on the Model 2001-SCAN. Note that this command performs the same function as the :ROUte:OPEN ALL command that was previously discussed.

**Program fragment**

```
PRINT #1, "output 16; :rout:open:all" ' Open all channels
```

**3.17.4**

**:SCAN commands**

**[:INternal] <list>**

:ROUte:SCAN[:INternal] <list> Define internal scan list and enable scan.

**Parameters**

<list> = (@ scanlist)

where; scanlist is the specified list of channels (1 to 10) to be scanned.

**Query**

[:INternal]? Query programmed scan list

**Description**

This command is used to define the scan list for the internal Model 2001-SCAN scanner card. The scan list can contain 2 to 10 channels. The following examples demonstrate the various forms for expressing a scan list:

```
list = (@ 2,4,6) Channels separated by commas (.).
 (@ 1:8) Range of channels (1 though 8). Range limits separated by a colon (:).
 (@ 1:5,7) Range entry and single entry separated by a comma.
```

See paragraph 2.11 and the Model 2001-SCAN instruction manual for details on scanning.

**Program fragment**

```
PRINT #1, "output 16; :rout:scan (@ 1:5)" ' Define scan list and scan chan-
 nels
```

**:EXternal <list>**

:ROUTE:SCAN:EXternal &lt;list&gt; Define external scan list

**Parameters**

&lt;list&gt; = (@ scanlist)

where; scanlist is the specified list of external channels (1 to 80) to be scanned.

**Query**

:EXternal? Query programmed scan list

**Description**

The Model 2002 can operate with an external switch system, such as the Keithley Model 7001 or 7002. The Model 2002 can measure up to 80 channels that are switched by the external switching system. This command is used to define the external scan list for the Model 2002. See paragraph 2.11 for details on scanning.

The scan list can contain 2 to 80 channels. See :SCAN[:INternal] for examples to express a scan list. The external scan by the Model 2002 is enabled by the ROUTE:SCAN:LSElect EXternal command.

**Program fragment**

```
PRINT #1, "output 16; :rout:scan:ext (@ 1:40)" ' Define external scan
 list
```

**:FUNction <list>, <name>**

```
:ROUTE:SCAN[:INternal]:FUNction <list>, <name> Assign functions to channels; Internal
:ROUTE:SCAN:EXternal:FUNction <list>, <name> Assign functions to channels; External
```

**Parameters**

&lt;list&gt; = (@ chanlist)

where; chanlist is the specified list of channels:

1 to 10 for Internal  
1 to 80 for External

```
<name> = 'NONE'
 'VOLTage:DC'
 'VOLTage:AC'
 'TEMPerature'
 'FREQuency'
 'RESistance'
 'FRESistance'
 'RJUNctionX' where; X = 1 to 5
 'ALternate[1]'
 'CURRent:DC' (External only)
 'CURRent:AC' (External only)
```

**Query**

:FUNction? &lt;list&gt; Query functions for specified channels

**Description**

These commands are used to assign measurement functions for internal channels (e.g. Model 2001 SCAN) or external channels. You can assign a unique measurement function to each channel. The function parameter specifies the measurement function for the channels specified by the channel list (chanlist). See :CLOSE for examples to express a chanlist.

The function parameter specifies the measurement function for the channels listed in the chanlist. As a scan is being performed, the Model 2002 will select the specified measurement function for each channel in the scan.

Any measurement function, except current (ACI and DCI), can be used for internal scanning. Note that the Keithley Model 2001-SCAN scanner card cannot be used to make thermocouple temperature measurements. Any measurement function can be used for external scanning (assuming you are using the appropriate switching card).

With the NONE function parameter selected, the channels specified in the chanlist will not be scanned. This will not change the defined scan list, it will simply cause the specified channels to be skipped.

With the ALternate function parameter selected, the specified channels in the chanlist will be measured according to the saved alternate setup conditions. An alternate setup is saved using the [:SENSe[1]]:ALternate SAVE command (see Sense subsystem).

### Program fragment

```
' Assign DCV to specified channels
PRINT #1, "output 16; :rout:scan:func (@ 1,3,5,7), 'volt:dc'"
```

### **:RCHannel <list>**

```
:ROUte:SCAN:RATio:RCHannel <list> Specify reference channel for Ratio
:ROUte:SCAN:DELta:RCHannel <list> Specify reference channel for Delta
```

### Parameters

<list> = (@ chanlist)

where; chanlist is a single channel number (1 to 10)

### Query

:RCHannel? Query reference channel

### Description

These commands are used to select the reference channel for the ratio and delta calculations. Note that channel 5 and channel 10 (which is the default) are the high speed solid state switches on the Model 2001-SCAN. See paragraph 2.11 for details.

### Program fragment

```
PRINT #1, "output 16; :rout:scan:rat:rch (@ 1); rch?" ' Select and query ref-
 erence channel
PRINT #1, "enter 16" ' Get response message
 from 2002
```

### **:MCHannel <list>**

```
:ROUte:SCAN:RATio:MCHannel <list> Specify measure channel for Ratio
:ROUte:SCAN:DELta:MCHannel <list> Specify measure channel for Delta
```

### Parameters

<list> = (@ chanlist)

where; chanlist is a single channel number (1 to 10)

### Query

:MCHannel? Query measure channel

### Description

These commands are used to select the measure channel for the ratio and delta calculations. Note that channel 5 and channel 10 (which is the default) are the high speed solid state switches on the Model 2001-SCAN. See paragraph 2.11 for details.



**Program fragment**

```
'PRINT #1, "output 16; :rout:scan:rat:mch (@ 2); mch?"
PRINT #1, "enter 16"
```

' Select and query reference channel  
' Get response message from 2002

**:LSElect <name>**

:ROUTe:SCAN:LSElect <name> Perform specified scan operation

**Parameters**

|          |          |                                       |
|----------|----------|---------------------------------------|
| <name> = | INTernal | Enable scan for internal scanner card |
|          | EXTernal | Enable scan for external scanner card |
|          | RATio    | Perform ratio calculation             |
|          | DELTA    | Perform delta calculation             |
|          | NONE     | Disable all scan operations           |

**Query**

:LSElect? Query scan operation

**Description**

This command is used to select and perform the desired scan operation. When INTernal is selected, the Model 2002 scans the channels of the internal switching card according to how the scan is configured (see :ROUTe:SCAN[:INTernal]). EXTernal is used to measure channels that are controlled by an external switch system. When EXTernal is selected, the Model 2002 scans the external scan list (see :SCAN:EXTernal).

With RATio or DELTA selected, the Model 2002 performs the appropriate math calculation using the specified reference channel and measure channel (see :RCHannel and :MCHannel).

The NONE selection disables all operations associated with a scan.

**Program fragment**

```
PRINT #1, "output 16; :syst:pres" ' Return 2002 to defaults
PRINT #1, "output 16; :rout:scan:lse1 int" ' Scan internal channels
```

## 3.18 Sense subsystems

The Sense subsystems are used to configure and control the measurement functions (Sense 1) and to read the digital input port (Sense 2). The commands for the Sense subsystems are summarized in Table 3-10.

### 3.18.1 [:SENSe[1]] subsystem

This Sense 1 Subsystem is used to configure and control the measurement functions of the Model 2002. Keep in mind that a function does not have to be selected in order to program its various configurations. When the function is later selected, it assumes the programmed states.

### 3.18.2 :ALTErnate[1] commands

#### :SAVE

[:SENSe[1]]:ALTErnate[1]:SAVE    Save Alternate setup.

#### Description

This command is used to save the current instrument setup as the Alternate setup. The instrument can be returned to the Alternate setup by using the :ALTErnate[1]:RECall command.

An Alternate setup can be used as the function parameter for a scan (see :ROUte :SCAN).

#### Program fragment

```
PRINT #1, "output 16; :alt:save" ' Save present setup as alternate setup
```

#### :RECall

[:SENSe[1]]:ALTErnate[1]:RECall    Return to Alternate setup.

#### Description

This command is used to return the instrument to an Alternate setup (see :ALTErnate[1]:SAVE). If there is no Alternate setup currently saved, this command is a No-Op (no operation).

#### Program fragment

```
PRINT #1, "output 16; :alt:rec" ' Recall alternate setup
```

### 3.18.3 :FUNction <name>

[:SENSe[1]]:FUNction <name>    Select measurement function.

#### Parameters

|          |               |                   |
|----------|---------------|-------------------|
| <name> = | 'VOLTage:AC'  | Select ACV        |
|          | 'VOLTage:DC'  | Select DCV        |
|          | 'RESistance'  | Select $\Omega$ 2 |
|          | 'FRESistance' | Select $\Omega$ 4 |
|          | 'CURRent:AC'  | Select ACI        |
|          | 'CURRent:DC'  | Select DCI        |
|          | 'FREQuency'   | Select FREQ       |
|          | 'TEMPerature' | Select TEMP       |

#### Query

:FUNction?    Query currently programmed function.

**Description**

The :FUNcTION command is used to select the measurement function of the instrument. Note that parameter names are enclosed in single quotes ('). However, double quotes (") can instead be used. For example:

```
:func 'volt:dc' = :func "volt:dc"
```

Each measurement function “remembers” its own unique setup configuration, such as range, speed, resolution, filter and rel. This eliminates the need to re-program setup conditions every time you switch from one function to another.

**Program fragment**

```
PRINT #1, "output 16; :func 'volt:ac'; func?" ' Select ACV function
PRINT #1, "enter 16" ' Get response from 2002
```

**3.18.4****:DATA commands**

```
[:LATest]?
```

```
[:SENSe[1]]:DATA[:LATest]?
```

Return latest reading.

**Description**

This query command is used to read the latest instrument reading. This command returns the “raw” reading or a reading that is the result of the Reference (REL from the front panel) operation. For example, if a reference value of 1.0 is established, the reading returned by this command is the “raw” reading minus 1.0. Calculated (MATH) readings cannot be read with this command (see the CALCulate subsystem to read math calculations).

The reading is returned in exponent form. For example, a 10V DC reading will be displayed on the CRT as follows:

```
+1.000000E+01
```

Notice that the measurement function is not included in the response message. Thus, you may want to perform a function query (see previous command) after a reading query.

**Program fragment**

```
PRINT #1, "output 16; :data?; func?" ' Query a reading and query function
PRINT #1, "enter 16" ' Get response from 2002
```

**:FRESH?**

```
[:SENSe[1]]:DATA:FRESH?
```

Return new reading.

**Description**

This query command is used to return a new (fresh) reading. This command will not request the same reading twice. If a new reading is triggered, this command will wait until the reading is available, rather than request the old reading.

**Program fragment**

```
PRINT #1, "output 16; :data:fresh?" ' Query new reading
PRINT #1, "enter 16" ' Get response from 2002
```

**3.18.5 :APERTure <n>**

|                                       |                       |
|---------------------------------------|-----------------------|
| [ :SENSe[1]]:CURRent:AC:APERTure <n>  | Set aperture for ACI  |
| [ :SENSe[1]]:CURRent:DC:APERTure <n>  | Set aperture for DCI  |
| [ :SENSe[1]]:VOLTage:AC:APERTure <n>  | Set aperture for ACV  |
| [ :SENSe[1]]:VOLTage:DC:APERTure <n>  | Set aperture for DCV  |
| [ :SENSe[1]]:RESistance:APERTure <n>  | Set aperture for Ω2   |
| [ :SENSe[1]]:FRESistance:APERTure <n> | Set aperture for Ω4   |
| [ :SENSe[1]]:TEMPerature:APERTure <n> | Set aperture for TEMP |

|                   |                             |                                                                                                        |
|-------------------|-----------------------------|--------------------------------------------------------------------------------------------------------|
| <b>Parameters</b> | <n> = 166.666666667e-6 to 1 | Integration period in seconds                                                                          |
|                   | DEFault                     | Power line cycle integration:<br>16.67msec for 60Hz power line<br>20msec for 50Hz and 400Hz power line |
|                   | MINimum                     | 166.666666667e-6sec                                                                                    |
|                   | MAXimum                     | 1sec                                                                                                   |
| <b>Query</b>      | :APERTure?                  | Query programmed aperture value.                                                                       |
|                   | :APERTure? DEFault          | Query *RST default aperture value.                                                                     |
|                   | :APERTure? MINimum          | Query minimum aperture value.                                                                          |
|                   | :APERTure? MAXimum          | Query maximum aperture value.                                                                          |

**Description**

The integration period (measurement speed) for the Model 2002 can be set using either of two commands; NPLCycle (paragraph 3.18.6) or :APERTure. The NPLC method specifies the integration period as the number of power line cycles per integration, while aperture specifies the time (in seconds) per integration. Refer to paragraph 2.4 for details on integration (SPEED). The relationship between NPLC and aperture is expressed as follows:

$$\text{Aperture} = \frac{\text{NPLC}}{f}$$

where; Aperture is the integration rate in seconds per integration.  
NPLC is the number of power line cycles per integration.  
f is the power line frequency. (Note: For 400Hz line power, use 50Hz to calculate aperture).

When the integration period is set using the :APERTure command, the value for the :NPLCycle command changes accordingly to reflect the new integration period. Conversely, if the integration period is set using the :NPLCycle command, the value for the :APERTure command changes accordingly.

On power-up, the instrument uses the NPLC value to determine the integration period. Thus, if using a different power line frequency, NPLC will remain the same, but aperture may change.

Note: If line synchronization is enabled (see:LSYNc command in SYSTem subsystem), the integration period will not start until the beginning of the next power line cycle. For example, if a reading is triggered at the positive peak of a power line cycle, the integration period will not start until that power line cycle is completed. The integration period starts when the positive-going sine wave crosses zero volts. See paragraph 2.12.7 for more details.

**Program fragment**

```
PRINT #1, "output 16; :curr:ac:aper 16.67e-3; aper?" ' Select aperture for ACI
PRINT #1, "enter 16" ' Get response from 2002
```

**:AUTO <b>| ONCE**

```
[:SENSe[1]]:CURRent:AC:APERture:AUTO |ONCE Control auto aperture for ACI
[:SENSe[1]]:CURRent:DC:APERture:AUTO |ONCE Control auto aperture for DCI
[:SENSe[1]]:VOLTage:AC:APERture:AUTO |ONCE Control auto aperture for ACV
[:SENSe[1]]:VOLTage:DC:APERture:AUTO |ONCE Control auto aperture for DCV
[:SENSe[1]]:RESistance:APERture:AUTO |ONCE Control auto aperture for Ω2
[:SENSe[1]]:FRESistance:APERture:AUTO |ONCE Control auto aperture for Ω4
[:SENSe[1]]:TEMPerature:APERture:AUTO |ONCE Control auto aperture for TEMP
```

**Parameters**

```
 = 1 or ON Enable auto aperture
 0 or OFF Disable auto aperture
ONCE Enable and then disable auto aperture
```

**Query**

```
:AUTO? Query state of auto aperture.
```

**Description**

These commands are used to enable or disable auto aperture for the specified measurement function. With auto aperture enabled, the instrument automatically optimizes the aperture value for the present resolution setting. This is the same as selecting SET-BY-RSLN from the front panel (see paragraph 2.4).

Tables 2-8, 2-13, 2-18 and 2-24 provide the integration times for SET-BY-RSLN (AUTO). Note that the times are provided as NPLC values. To convert to aperture times, use the formula in paragraph 3.18.5.

The ONCE parameter is analogous to a momentary toggle switch. When :AUTO ONCE is sent, auto aperture turns on momentarily and then disables. While enabled, it automatically selects the appropriate value as summarized in the tables. When auto aperture disables, the aperture remains at the selected value.

:APERture:AUTO is coupled to the command that manually sets the aperture value (:APERture <n>). When auto aperture is enabled, the parameter value for :APERture <n> changes to the automatically selected aperture value. Thus, when auto aperture is disabled, the aperture remains at the automatically selected value. Also, a valid aperture value sent using the :APERture <n> command disables auto aperture.

Auto aperture is also coupled to auto NPLC. Enabling or disabling auto aperture also enables or disables auto NPLC. Also, a valid NPLC value sent using the :NPLC command disables auto aperture.

**Program fragment**

```
PRINT #1, "output 16; :curr:ac:aper:auto on; auto?" ' Enable auto APER for ACI
PRINT #1, "enter 16" ' Get response from 2002
```

**3.18.6****:NPLCycles <n>**

```
[:SENSe[1]]:CURRent:AC:NPLCycles <n> Set NPLC for ACI
[:SENSe[1]]:CURRent:DC:NPLCycles <n> Set NPLC for DCI
[:SENSe[1]]:VOLTage:AC:NPLCycles <n> Set NPLC for ACV
[:SENSe[1]]:VOLTage:DC:NPLCycles <n> Set NPLC for DCV
[:SENSe[1]]:RESistance:NPLCycles <n> Set NPLC for Ω2
[:SENSe[1]]:FRESistance:NPLCycles <n> Set NPLC for Ω4
[:SENSe[1]]:TEMPerature:NPLCycles <n> Set NPLC for TEMP
```

**Parameters**

```
<n> = 0.01 to 50 Power line cycles per integration
 DEFault 1
 MINimum 0.01
 MAXimum 50
```

|              |                     |                             |
|--------------|---------------------|-----------------------------|
| <b>Query</b> | :NPLCycles?         | Query programmed NPLC value |
|              | :NPLCycles? DEFault | Query *RST default value    |
|              | :NPLCycles? MINimum | Query minimum NPLC value    |
|              | :NPLCycles? MAXimum | Query maximum NPLC value    |

**Description**

The integration period (measurement speed) for the Model 2002 can be set using either of two commands; :APERTure (paragraph 3.18.5) or :NPLCycle. Aperture specifies time (in seconds) per integration, while NPLC expresses the integration period by basing it on the power line frequency. See paragraph 2.4 for details on integration (SPEED).

When the integration period is set using the :NPLCycles command, the time value for the :APERTure command changes accordingly to reflect the new integration rate. Conversely, if the integration period is set using the :APERTure command, the value for the :NPLCycle command changes accordingly.

On power-up, the instrument uses the NPLC value to determine the integration period.

Note: If line synchronization is enabled (see:LSYNc command in SYSTem subsystem), the integration period will not start until the beginning of the next power line cycle. For example, if a reading is triggered at the positive peak of a power line cycle, the integration period will not start until that power line cycle is completed. The integration period starts when the positive-going sine wave crosses zero volts. See paragraph 2.12.7 for more details.

**Program fragment**

```
PRINT #1, "output 16; :curr:ac:nplc 2; nplc?" ' Set NPLC for ACI
PRINT #1, "enter 16" ' Get response from 2002
```

**:AUTO <b>| ONCE**

|                                                    |                                  |
|----------------------------------------------------|----------------------------------|
| [ :SENSe[1] ] :CURRent:AC:NPLCycles:AUTO <b> ONCE  | Control auto NPLC for ACI        |
| [ :SENSe[1] ] :CURRent:DC:NPLCycles:AUTO <b> ONCE  | Control auto NPLC for DCI        |
| [ :SENSe[1] ] :VOLTag:AC:NPLCycles:AUTO <b> ONCE   | Control auto NPLC for ACV        |
| [ :SENSe[1] ] :VOLTag:DC:NPLCycles:AUTO <b> ONCE   | Control auto NPLC for DCV        |
| [ :SENSe[1] ] :RESistance:NPLCycles:AUTO <b> ONCE  | Control auto NPLC for $\Omega 2$ |
| [ :SENSe[1] ] :FRESistance:NPLCycles:AUTO <b> ONCE | Control auto NPLC for $\Omega 4$ |
| [ :SENSe[1] ] :TEMPerature:NPLCycles:AUTO <b> ONCE | Control auto NPLC for TEMP       |

**Parameters**

|               |                                   |
|---------------|-----------------------------------|
| <b> = 1 or ON | Enable auto NPLC                  |
| 0 or OFF      | Disable auto NPLC                 |
| ONCE          | Enable and then disable auto NPLC |

**Query**

:AUTO? Query state of auto NPLC

**Description**

These commands are used to enable or disable auto NPLC for the specified measurement function. With auto NPLC enabled, the instrument automatically optimizes the NPLC value for the present resolution setting. Tables 2-8, 2-13, 2-18 and 2-24 provide the integration times for SET-BY-RSLN (AUTO).

The ONCE parameter is analogous to a momentary toggle switch. When :AUTO ONCE is sent, auto NPLC turns on momentarily and then disables. While enabled, it automatically selects the appropriate value as summarized in the tables. When auto NPLC disables, NPLC remains at the selected value.

:NPLC:AUTO is coupled to the command that manually sets the NPLC value (:NPLC <n>). When auto NPLC is enabled, the parameter value for :NPLC <n> changes to the automatically selected NPLC value. Thus, when auto NPLC is disabled, NPLC remains at the automatically

selected value. Also, a valid NPLC value sent using the :NPLC <n> command disables auto NPLC.

Auto NPLC is also coupled to auto aperture. Enabling or disabling auto NPLC also enables or disables auto Aperture. Also, a valid aperture value sent using the :APERture command disables auto NPLC.

**Program fragment**

```
PRINT #1, "output 16; :curr:ac:nplc:auto on; auto?" ' Enable auto NPLC for ACI
PRINT #1, "enter 16" ' Get response from 2002
```

**3.18.7****:COUPling AC|DC**

```
[:SENSe[1]]:CURRent:COUPling AC|DC Specify coupling for ACI
[:SENSe[1]]:VOLTagE:COUPling AC|DC Specify coupling for ACV
[:SENSe[1]]:FREQUency:COUPling AC|DC Specify coupling for FREQ
```

**Parameters**

AC AC coupling  
DC AC+DC coupling

**Query**

:COUPling? Query currently programmed coupling

**Description**

This command is used to select the input coupling for the AC, ACV and the FREQ functions. When AC coupling is selected, a DC blocking capacitor is placed in series with the AC measurement circuit. This removes the DC component from the measurement.

When DC coupling is selected, the blocking capacitor is removed. Subsequent measurements reflect both the AC and DC components of the signal (AC+DC).

**Program fragment**

```
PRINT #1, "output 16; :curr:ac:coup dc; coup?" ' Select AC+DC for ACI
PRINT #1, "enter 16" ' Get response from 2002
```

**3.18.8****RANGe commands****[ :UPPer ] <n>**

```
[:SENSe[1]]:CURRent:AC:RANGe[:UPPer] <n> Set measurement range for ACI
[:SENSe[1]]:CURRent:DC:RANGe[:UPPer] <n> Set measurement range for DCI
[:SENSe[1]]:VOLTagE:AC:RANGe[:UPPer] <n> Set measurement range for ACV
[:SENSe[1]]:VOLTagE:DC:RANGe[:UPPer] <n> Set measurement range for DCV
[:SENSe[1]]:RESistance:RANGe[:UPPer] <n> Set measurement range for Ω2
[:SENSe[1]]:FREStance:RANGe[:UPPer] <n> Set measurement range for Ω4
```

**Parameters**

|                |                                                                           |
|----------------|---------------------------------------------------------------------------|
| <n> = 0 to 2.1 | Expected reading in amps (ACI and DCI)                                    |
| 0 to 775       | Expected reading in AC volts (ACV)                                        |
| 0 to 1100      | Expected reading in DC volts (DCV)                                        |
| 0 to 1.05e9    | Expected reading in ohms (Ω2)                                             |
| 0 to 2.1e6     | Expected reading in ohms (Ω4)                                             |
| DEFault        | 2.1 (ACI and DCI)<br>775 (ACV)<br>1100 (DCV)<br>1.05e9 (Ω2)<br>2.1e6 (Ω4) |
| MINimum        | 0 (All functions)                                                         |
| MAXimum        | Same as DEFault                                                           |

|              |                         |                                 |
|--------------|-------------------------|---------------------------------|
| <b>Query</b> | :RANGe[:UPPer]?         | Query ACI measurement range     |
|              | :RANGe[:UPPer]? DEFault | Query *RST default range        |
|              | :RANGe[:UPPer]? MINimum | Query lowest measurement range  |
|              | :RANGe[:UPPer]? MAXimum | Query highest measurement range |

**Description**

This command is used to manually select the measurement range for the specified measurement function. The range is selected by specifying the expected reading as an absolute value. The Model 2002 will then go to the most sensitive range that will accommodate that expected reading. For example, if you expect a reading of approximately 100mA, simply let the parameter (<n>) = 0.1 (or 100e-3) in order to select the 200mA range.

**Program fragment**

```
PRINT #1, "output 16; :curr:ac:rang 1; rang?" ' Select 2A ACI range
PRINT #1, "enter 16" ' Get response from 2002
```

**:AUTO <b>| ONCE**

```
[:SENSe[1]]:CURRent:AC:RANGe:AUTO |ONCE Control auto range for ACI
[:SENSe[1]]:CURRent:DC:RANGe:AUTO |ONCE Control auto range for DCI
[:SENSe[1]]:VOLTag:AC:RANGe:AUTO |ONCE Control auto range for ACV
[:SENSe[1]]:VOLTag:DC:RANGe:AUTO |ONCE Control auto range for DCV
[:SENSe[1]]:RESistance:RANGe:AUTO |ONCE Control auto range for Ω2
[:SENSe[1]]:FREStance:RANGe:AUTO |ONCE Control auto range for Ω4
```

**Parameters**

```
 = 1 or ON Enable auto range
 0 or OFF Disable auto range
ONCE Enable and then disable auto range
```

**Query**

```
:AUTO? Query autorange (on or off)
```

**Description**

These commands are used to control autoranging. With autoranging enabled, the instrument automatically goes to the most sensitive range to perform the measurement (see paragraph 2.5.4 for details).

The ONCE parameter is analogous to a momentary toggle switch. When :RANGe:AUTO ONCE is sent, auto range enables and the most sensitive range is selected for the input signal. Auto range will then disable, but the selected measurement range is retained. Note that the instrument must currently be on the specified function in order for ONCE to be effective. Using ONCE while on any other function results in an error.

The autorange command (:RANGe:AUTO) is coupled to the command that manually selects the measurement range (:RANGe <n>). When autorange is enabled, the parameter value for :RANGe <n> changes to the automatically selected range value. Thus, when autorange is disabled, the instrument remains at the automatically selected range. When a valid :RANGe <n> command is sent, autoranging disables.

When using auto range, upper and lower range limits can be established to keep the instrument from autoranging to ranges that are not going to be used. (see :AUTO: ULIMit and :AUTO: LLIMit commands).

**Program fragment**

```
PRINT #1, "output 16; :curr:ac:rang:auto on; auto?" ' Enable auto range for
 ACI
PRINT #1, "enter 16" ' Get response from 2002
```



**:ULIMit <n>**

|                                                 |                                |
|-------------------------------------------------|--------------------------------|
| [ :SENSe[1] ]:CURRent:AC:RANGe:AUTO:ULIMit <n>  | Set upper limit for ACI        |
| [ :SENSe[1] ]:CURRent:DC:RANGe:AUTO:ULIMit <n>  | Set upper limit for DCI        |
| [ :SENSe[1] ]:VOLTage:AC:RANGe:AUTO:ULIMit <n>  | Set upper limit for ACV        |
| [ :SENSe[1] ]:VOLTage:DC:RANGe:AUTO:ULIMit <n>  | Set upper limit for DCV        |
| [ :SENSe[1] ]:RESistance:RANGe:AUTO:ULIMit <n>  | Set upper limit for $\Omega 2$ |
| [ :SENSe[1] ]:FRESistance:RANGe:AUTO:ULIMit <n> | Set upper limit for $\Omega 4$ |

**:LLIMit <n>**

|                                                 |                                |
|-------------------------------------------------|--------------------------------|
| [ :SENSe[1] ]:CURRent:AC:RANGe:AUTO:LLIMit <n>  | Set lower limit for ACI        |
| [ :SENSe[1] ]:CURRent:DC:RANGe:AUTO:LLIMit <n>  | Set lower limit for DCI        |
| [ :SENSe[1] ]:VOLTage:AC:RANGe:AUTO:LLIMit <n>  | Set lower limit for ACV        |
| [ :SENSe[1] ]:VOLTage:DC:RANGe:AUTO:LLIMit <n>  | Set lower limit for DCV        |
| [ :SENSe[1] ]:RESistance:RANGe:AUTO:LLIMit <n>  | Set lower limit for $\Omega 2$ |
| [ :SENSe[1] ]:FRESistance:RANGe:AUTO:LLIMit <n> | Set lower limit for $\Omega 4$ |

**Parameters**

|                |                                                                                               |
|----------------|-----------------------------------------------------------------------------------------------|
| <n> = 0 to 2.1 | Range limit for ACI and DCI                                                                   |
| 0 to 775       | Range limit for ACV                                                                           |
| 0 to 1100      | Range limit for DCV                                                                           |
| 0 to 1.05e9    | Range limit for $\Omega 2$                                                                    |
| 0 to 2.1e6     | Range limit for $\Omega 4$                                                                    |
| DEFault        | 2.1 (ACI and DCI)<br>775 (ACV)<br>1100 (DCV)<br>1.05e9 ( $\Omega 2$ )<br>2.1e6 ( $\Omega 4$ ) |
| MINimum        | 0 (All functions)                                                                             |
| MAXimum        | Same as DEFault                                                                               |

**Query**

|                  |                                     |
|------------------|-------------------------------------|
| :ULIMit?         | Query upper range limit             |
| :ULIMit? DEFault | Query *RST default upper limit      |
| :ULIMit? MINimum | Query lowest allowable upper limit  |
| :ULIMit? MAXimum | Query largest allowable upper limit |
| :LLIMit?         | Query lower range limit             |
| :LLIMit? DEFault | Query *RST default lower limit      |
| :LLIMit? MINimum | Query lowest allowable lower limit  |
| :LLIMit? MAXimum | Query largest allowable lower limit |

**Description**

Automatic range changes slow down the reading rate. By setting upper and lower measurement range limits, you can prevent inadvertent range changes to ranges that you are not going to use.

The upper range limit is selected by specifying the maximum expected reading that you expect to measure. For example, if the maximum expected reading is approximately 100mA, let the parameter (<n>) = 0.1 (or 100e-3). The lowest (most sensitive) range that can measure 100mA is the 200mA range. Thus, the 200mA range is selected as the upper range limit. With this upper limit, the instrument cannot uprange to the 2A measurement range.

The lower range limit is selected by specifying the lowest expected reading that you expect to measure.

**Program fragment**

```
PRINT #1, "output 16; :curr:ac:rang:auto:ulim 1" ' Set upper limit for ACI
 ' Set lower limit and query
 limits
PRINT #1, "output 16; :curr:ac:rang:auto:llim 10e-3; ulim?; llim?"
PRINT #1, "enter 16" ' Get response from 2002
```

## 3.18.9

**:REference <n>**

|                                                          |                                  |
|----------------------------------------------------------|----------------------------------|
| <code>[:SENSe[1]]:CURRent:AC:REference &lt;n&gt;</code>  | Specify reference for ACI        |
| <code>[:SENSe[1]]:CURRent:DC:REference &lt;n&gt;</code>  | Specify reference for DCI        |
| <code>[:SENSe[1]]:VOLTage:AC:REference &lt;n&gt;</code>  | Specify reference for ACV        |
| <code>[:SENSe[1]]:VOLTage:DC:REference &lt;n&gt;</code>  | Specify reference for DCV        |
| <code>[:SENSe[1]]:RESistance:REference &lt;n&gt;</code>  | Specify reference for $\Omega 2$ |
| <code>[:SENSe[1]]:FREStance:REference &lt;n&gt;</code>   | Specify reference for $\Omega 4$ |
| <code>[:SENSe[1]]:FREQuency:REference &lt;n&gt;</code>   | Specify reference for FREQ       |
| <code>[:SENSe[1]]:TEMPerature:REference &lt;n&gt;</code> | Specify reference for TEMP       |

**Parameters**

|                                       |                                      |
|---------------------------------------|--------------------------------------|
| <code>&lt;n&gt; = -2.1 to +2.1</code> | Reference for ACI and DCI            |
| <code>-1100 to +1100</code>           | Reference for DCV and ACV            |
| <code>0 to 1.05e9</code>              | Reference for $\Omega 2$             |
| <code>0 to 2.1e6</code>               | Reference for $\Omega 4$             |
| <code>0 to 1.5e7</code>               | Reference for FREQ                   |
| <code>-328 to +3310</code>            | Reference for TEMP ( $^{\circ}$ F)   |
| <code>-200 to +1821</code>            | Reference for TEMP ( $^{\circ}$ C)   |
| <code>73 to 2094</code>               | Reference for TEMP (K)               |
| <code>DEFAult</code>                  | 0 (All functions)                    |
| <code>MINimum</code>                  | Minimum value for specified function |
| <code>MAXimum</code>                  | Maximum value for specified function |

**Query**

|                                  |                                         |
|----------------------------------|-----------------------------------------|
| <code>:REference?</code>         | Query programmed reference value        |
| <code>:REference? DEFAult</code> | Query *RST default reference value      |
| <code>:REference? MINimum</code> | Query lowest allowable reference value  |
| <code>:REference? MAXimum</code> | Query largest allowable reference value |

**Description**

These commands are used to establish a reference value for the specified function. When Reference is enabled (see `:REference:STATE`), the result will be the algebraic difference between the input signal and the reference value:

Reading = Input signal - Reference

From the front panel, reference is called relative (REL). See paragraph 2.6 for more information on REL.

The `:REference <n>` command is coupled to the `:ACQUIRE` command. The last command sent (`:REference <n>` or `:ACQUIRE`) establishes the reference. When a reference is set using the `:REference <n>` command, the `:REference?` query command returns the programmed value. Conversely, when a reference is set using the `:ACQUIRE` command, the `:REference?` query command returns the acquired reference value.

**Program fragment**

```
PRINT #1, "output 16; :curr:ac:ref 1; ref?" ' Set reference to 1A
PRINT #1, "enter 16" ' Get response from 2002
```

**:STATE <b>**

|                                              |                                  |
|----------------------------------------------|----------------------------------|
| [ :SENSe[1]]:CURRent:AC:REFerence:STATe <b>  | Control reference for ACI        |
| [ :SENSe[1]]:CURRent:DC:REFerence:STATe <b>  | Control reference for DCI        |
| [ :SENSe[1]]:VOLTagE:AC:REFerence:STATe <b>  | Control reference for ACV        |
| [ :SENSe[1]]:VOLTagE:DC:REFerence:STATe <b>  | Control reference for DCV        |
| [ :SENSe[1]]:RESistance:REFerence:STATe <b>  | Control reference for $\Omega 2$ |
| [ :SENSe[1]]:FREStance:REFerence:STATe <b>   | Control reference for $\Omega 4$ |
| [ :SENSe[1]]:FREQuency:REFerence:STATe <b>   | Control reference for FREQ       |
| [ :SENSe[1]]:TEMPerature:REFerence:STATe <b> | Control reference for TEMP       |

**Parameters**

<b> = 1 or ON    Enable reference  
0 or OFF    Disable reference

**Query**

:STATE?    Query state of reference

**Description**

These commands are used to enable or disable Reference for the specified function. When enabled, the displayed reading will include the programmed reference value (see :REFERENCE <n> and :ACQUIRE). When disabled, the displayed reading will not include the reference value.

**Program fragment**

```
PRINT #1, "output 16; :curr:ac:ref:stat on; stat?" ' Enable reference
PRINT #1, "enter 16" ' Get response from 2002
```

**:ACQUIRE**

|                                            |                                  |
|--------------------------------------------|----------------------------------|
| [ :SENSe[1]]:CURRent:AC:REFerence:ACQUIRE  | Acquire Reference for ACI        |
| [ :SENSe[1]]:CURRent:DC:REFerence:ACQUIRE  | Acquire Reference for DCI        |
| [ :SENSe[1]]:VOLTagE:AC:REFerence:ACQUIRE  | Acquire Reference for ACV        |
| [ :SENSe[1]]:VOLTagE:DC:REFerence:ACQUIRE  | Acquire Reference for DCV        |
| [ :SENSe[1]]:RESistance:REFerence:ACQUIRE  | Acquire Reference for $\Omega 2$ |
| [ :SENSe[1]]:FREStance:REFerence:ACQUIRE   | Acquire Reference for $\Omega 4$ |
| [ :SENSe[1]]:FREQuency:REFerence:ACQUIRE   | Acquire Reference for FREQ       |
| [ :SENSe[1]]:TEMPerature:REFerence:ACQUIRE | Acquire Reference for TEMP       |

**Description**

When one of these commands is sent, the measured input signal is acquired and established as the reference value. This command is typically used to zero the display. For example, if the instrument is displaying a 2mA offset, sending this command and enabling Reference (see :STATE) zeroes the display.

This command is functional only if the instrument is on the specified measurement function. Sending this command while in any other function causes an error. Also, if the latest reading is overflowed ("OFLO") or a reading has not been triggered ("----"), an error occurs when this command is sent.

The :ACQUIRE command is coupled to the :REFERENCE <n> command. See the description for :REFERENCE for details.

**Program fragment**

```
PRINT #1, "output 16; :func 'volt:dc'" ' Select DCV function
SLEEP 1 ' Allow reading to settle
PRINT #1, "output 16; :volt:dc:ref:acq; stat on" ' Acquire and enable refer-
ence
PRINT #1, "output 16; :volt:dc:ref?" ' Query reference value
PRINT #1, "enter 16" ' Get response from 2002
```

## 3.18.10

**:DIGits <n>**

|                                                       |                                   |
|-------------------------------------------------------|-----------------------------------|
| <code>[:SENSe[1]]:CURRent:AC:DIGits &lt;n&gt;</code>  | Specify resolution for ACI        |
| <code>[:SENSe[1]]:CURRent:DC:DIGits &lt;n&gt;</code>  | Specify resolution for DCI        |
| <code>[:SENSe[1]]:VOLTage:AC:DIGits &lt;n&gt;</code>  | Specify resolution for ACV        |
| <code>[:SENSe[1]]:VOLTage:DC:DIGits &lt;n&gt;</code>  | Specify resolution for DCV        |
| <code>[:SENSe[1]]:RESistance:DIGits &lt;n&gt;</code>  | Specify resolution for $\Omega 2$ |
| <code>[:SENSe[1]]:FREStance:DIGits &lt;n&gt;</code>   | Specify resolution for $\Omega 4$ |
| <code>[:SENSe[1]]:FREQuency:DIGits &lt;n&gt;</code>   | Specify resolution for FREQ       |
| <code>[:SENSe[1]]:TEMPerature:DIGits &lt;n&gt;</code> | Specify resolution for TEMP       |

**Parameters**

|                            |   |                                                        |
|----------------------------|---|--------------------------------------------------------|
| <code>&lt;n&gt; = 4</code> | 3 | digits for DCI, ACI, ACV, DCV, $\Omega 2$ , $\Omega 4$ |
|                            | 3 | digits (1° resolution) for TEMP                        |
| 5                          | 4 | digits for FREQ                                        |
|                            | 4 | digits for DCI, ACI, ACV, DCV, $\Omega 2$ , $\Omega 4$ |
| 6                          | 4 | digits (0.1° resolution) for TEMP                      |
|                            | 5 | digits for FREQ                                        |
| 7                          | 5 | digits for DCI, ACI, ACV, DCV, $\Omega 2$ , $\Omega 4$ |
|                            | 5 | digits (0.01° resolution) for TEMP                     |
| 8                          | 6 | digits for DCI, ACI, ACV, DCV, $\Omega 2$ , $\Omega 4$ |
|                            | 6 | digits (0.001° resolution) for TEMP                    |
| 9                          | 7 | digits for DCI, ACI, ACV, DCV, $\Omega 2$ , $\Omega 4$ |
|                            | 8 | digits for DCI, ACI, ACV, DCV, $\Omega 2$ , $\Omega 4$ |
| DEFAult                    | 7 | digits for DCV, $\Omega 2$ and $\Omega 4$              |
|                            | 6 | digits for DCI and ACI                                 |
| MINimum                    | 5 | digits for ACV                                         |
|                            | 5 | digits (0.01° resolution) for TEMP                     |
| MAXimum                    | 5 | digits for FREQ                                        |
|                            | 3 | digits for DCI, ACI, ACV, DCV, $\Omega 2$ , $\Omega 4$ |
|                            | 3 | digits (1° resolution) for TEMP                        |
|                            | 4 | digits for FREQ                                        |
|                            | 8 | digits for DCI, ACI, ACV, DCV, $\Omega 2$ , $\Omega 4$ |
|                            | 6 | digits (0.001° resolution) for TEMP                    |
|                            | 5 | digits for FREQ                                        |

**Query**

|                               |                                    |
|-------------------------------|------------------------------------|
| <code>:DIGits?</code>         | Query selected resolution          |
| <code>:DIGits? DEFAult</code> | Query *RST default resolution      |
| <code>:DIGits? MINimum</code> | Query minimum allowable resolution |
| <code>:DIGits? MAXimum</code> | Query maximum allowable resolution |

**Description**

These commands are used to select display resolution for the specified measurement function.

Even though the parameters for this command are expressed as integers (4 to 9), you can specify resolution using real numbers. For example, to select 3 digit resolution let `<n> = 3.5`, for 4 d let `<n> = 4.5`, and so on. Internally, the instrument rounds the entered parameter value to the nearest integer.

**Program fragment**

```
PRINT #1, "output 16; :volt:dc:dig 4.5; dig?" ' Select 4 d DCV resolution
PRINT #1, "enter 16" ' Get response from 2002
```

**:AUTO <b>| ONCE**

|                                               |                                        |
|-----------------------------------------------|----------------------------------------|
| [ :SENSe[1]]:CURRent:AC:DiGits:AUTO <b> ONCE  | Control auto resolution for ACI        |
| [ :SENSe[1]]:CURRent:DC:DiGits:AUTO <b> ONCE  | Control auto resolution for DCI        |
| [ :SENSe[1]]:VOLTage:AC:DiGits:AUTO <b> ONCE  | Control auto resolution for ACV        |
| [ :SENSe[1]]:VOLTage:DC:DiGits:AUTO <b> ONCE  | Control auto resolution for DCV        |
| [ :SENSe[1]]:RESistance:DiGits:AUTO <b> ONCE  | Control auto resolution for $\Omega 2$ |
| [ :SENSe[1]]:FREStance:DiGits:AUTO <b> ONCE   | Control auto resolution for $\Omega 4$ |
| [ :SENSe[1]]:TEMPerature:DiGits:AUTO <b> ONCE | Control auto resolution for TEMP       |

**Parameters**

|       |          |                                         |
|-------|----------|-----------------------------------------|
| <b> = | 1 or ON  | Enable auto resolution                  |
|       | 0 or OFF | Disable auto resolution                 |
| ONCE  |          | Enable and then disable auto resolution |

**Query**

:AUTO? Query state of auto resolution

**Description**

These commands are used to enable or disable auto resolution for the specified function. With auto resolution selected, the instrument automatically selects the optimum resolution for the present integration time setting (see Tables 2-10, 2-15, 2-20 and 2-25).

The ONCE parameter is analogous to a momentary toggle switch. When :AUTO ONCE is sent, auto resolution turns on momentarily and then disables. While enabled, resolution is selected automatically. Auto resolution then disables but the selected value is retained.

The auto resolution command (:DiGits:AUTO) is coupled to the command that manually selects resolution (:DiGits <n>). When auto resolution is enabled, the parameter value for :DiGits <n> changes to the automatically selected resolution value. Thus, when auto resolution is disabled, the instrument remains at the automatically selected resolution.

**Program fragment**

```
PRINT #1, "output 16; :volt:dc:dig:auto on; auto?" ' Enable auto resolution
PRINT #1, "enter 16" ' Get response from 2002
```

**3.18.11****:AVERage commands**

The :AVERage commands are used to configure and control the filter. See paragraph 2.9 for details.

**:TCONtrol <name>**

|                                                  |                                   |
|--------------------------------------------------|-----------------------------------|
| [ :SENSe[1]]:CURRent:AC:AVERage:TCONtrol <name>  | Select filter type for ACI        |
| [ :SENSe[1]]:CURRent:DC:AVERage:TCONtrol <name>  | Select filter type for DCI        |
| [ :SENSe[1]]:VOLTage:AC:AVERage:TCONtrol <name>  | Select filter type for ACV        |
| [ :SENSe[1]]:VOLTage:DC:AVERage:TCONtrol <name>  | Select filter type for DCV        |
| [ :SENSe[1]]:RESistance:AVERage:TCONtrol <name>  | Select filter type for $\Omega 2$ |
| [ :SENSe[1]]:FREStance:AVERage:TCONtrol <name>   | Select filter type for $\Omega 4$ |
| [ :SENSe[1]]:TEMPerature:AVERage:TCONtrol <name> | Select filter type for TEMP       |

**Parameters**

|          |        |                         |
|----------|--------|-------------------------|
| <name> = | REPeat | Select repeating filter |
|          | MOVing | Select moving filter    |

**Query**

:TCONtrol? Query filter type

**Description**

These commands are used to select the type of averaging filter (REPeat or MOVing) for the specified function.

The number of readings that are averaged by the filter is set with the :AVERage:COUNT command. The :AVERage[:STATe] command is used to enable or disable the filter. Changing the filter type disables auto filter.

**Program fragment**

```
PRINT #1, "output 16; :volt:dc:aver:tcon rep; tcon?" ' Select repeating
 filter
PRINT #1, "enter 16" ' Get response from 2002
```

**:COUNT <n>**

|                                             |                               |
|---------------------------------------------|-------------------------------|
| [ :SENSe[1] ]:CURRent:AC:AVERage:COUNT <n>  | Specify filter count for ACI  |
| [ :SENSe[1] ]:CURRent:DC:AVERage:COUNT <n>  | Specify filter count for DCI  |
| [ :SENSe[1] ]:VOLTage:AC:AVERage:COUNT <n>  | Specify filter count for ACV  |
| [ :SENSe[1] ]:VOLTage:DC:AVERage:COUNT <n>  | Specify filter count for DCV  |
| [ :SENSe[1] ]:RESistance:AVERage:COUNT <n>  | Specify filter count for Ω2   |
| [ :SENSe[1] ]:FRESistance:AVERage:COUNT <n> | Specify filter count for Ω4   |
| [ :SENSe[1] ]:TEMPerature:AVERage:COUNT <n> | Specify filter count for TEMP |

**Parameters**

|       |          |                      |
|-------|----------|----------------------|
| <n> = | 1 to 100 | Specify filter count |
|       | DEFault  | 10                   |
|       | MINimum  | 1                    |
|       | MAXimum  | 100                  |

**Query**

|                 |                                          |
|-----------------|------------------------------------------|
| :COUNT?         | Query filter count                       |
| :COUNT? DEFault | Query the *RST default filter count      |
| :COUNT? MINimum | Query the lowest allowable filter count  |
| :COUNT? MAXimum | Query the largest allowable filter count |

**Description**

These commands are used to specify the filter count. In general, the filter count is the number of readings that are acquired and stored in the filter buffer for the averaging calculation. The larger the filter count, the more filtering that is performed.

**Program fragment**

```
PRINT #1, "output 16; :volt:dc:aver:coun 20; coun?" ' Set filter count
PRINT #1, "enter 16" ' Get response from 2002
```

**[:STATe] <b>**

|                                               |                         |
|-----------------------------------------------|-------------------------|
| [ :SENSe[1] ]:CURRent:AC:AVERage[:STATe] <b>  | Control filter for ACI  |
| [ :SENSe[1] ]:CURRent:DC:AVERage[:STATe] <b>  | Control filter for DCI  |
| [ :SENSe[1] ]:VOLTage:AC:AVERage[:STATe] <b>  | Control filter for ACV  |
| [ :SENSe[1] ]:VOLTage:DC:AVERage[:STATe] <b>  | Control filter for DCV  |
| [ :SENSe[1] ]:RESistance:AVERage[:STATe] <b>  | Control filter for Ω2   |
| [ :SENSe[1] ]:FRESistance:AVERage[:STATe] <b> | Control filter for Ω4   |
| [ :SENSe[1] ]:TEMPerature:AVERage[:STATe] <b> | Control filter for TEMP |

**Parameters**

|       |          |                            |
|-------|----------|----------------------------|
| <b> = | 0 or OFF | Disable the digital filter |
|       | 1 or ON  | Enable the digital filter  |

**Query**

|           |                               |
|-----------|-------------------------------|
| [:STATe]? | Query state of digital filter |
|-----------|-------------------------------|

**Description**

These commands are used to enable or disable the digital averaging filter for the specified function. When enabled, readings will be filtered according to how the filter is configured.

**Program fragment**

```
PRINT #1, "output 16; :volt:dc:aver on; aver?" ' Enable filter
PRINT #1, "enter 16" ' Get response from 2002
```

**:AUTO <b>| ONCE**

```
[:SENSe[1]]:CURRent:AC:AVERage:AUTO |ONCE Control auto filter for ACI
[:SENSe[1]]:CURRent:DC:AVERage:AUTO |ONCE Control auto filter for DCI
[:SENSe[1]]:VOLTage:AC:AVERage:AUTO |ONCE Control auto filter for ACV
[:SENSe[1]]:VOLTage:DC:AVERage:AUTO |ONCE Control auto filter for DCV
[:SENSe[1]]:RESistance:AVERage:AUTO |ONCE Control auto filter for Ω2
[:SENSe[1]]:FRESistance:AVERage:AUTO |ONCE Control auto filter for Ω4
[:SENSe[1]]:TEMPerature:AVERage:AUTO |ONCE Control auto filter for TEMP
```

**Parameters**

```
 = 0 or OFF Disable auto filter
 1 or ON Enable auto filter
ONCE Enable and then disable auto filter
```

**Query**

```
:AUTO? Query state of auto filter
```

**Description**

These commands are used to control auto filter for the specified function. The configuration for the filter is summarized in tables 2-9, 2-14 and 2-19.

Disabling auto filter has no effect on the currently programmed filter state and count.

The ONCE parameter is analogous to a momentary toggle switch. When ONCE is sent, the auto filter turns on momentarily and then disables.

**Program fragment**

```
PRINT #1, "output 16; :volt:dc:aver:auto on; auto?" ' Enable auto filter
PRINT #1, "enter 16" ' Get response from 2002
```

**:ADVanced commands****:NTOLerance <n>**

```
[:SENSe[1]]:CURRent:AC:AVERage:ADVanced:NTOLerance <n> Specify noise tolerance (ACI)
[:SENSe[1]]:CURRent:DC:AVERage:ADVanced:NTOLerance <n> Specify noise tolerance (DCI)
[:SENSe[1]]:VOLTage:AC:AVERage:ADVanced:NTOLerance <n> Specify noise tolerance (ACV)
[:SENSe[1]]:VOLTage:DC:AVERage:ADVanced:NTOLerance <n> Specify noise tolerance (DCV)
[:SENSe[1]]:RESistance:AVERage:ADVanced:NTOLerance <n> Specify noise tolerance (Ω2)
[:SENSe[1]]:FRESistance:AVERage:ADVanced:NTOLerance <n> Specify noise tolerance (Ω4)
```

**Parameters**

```
<n> = 1 to 100 Specify noise tolerance in percent (±)
 DEFault ±1% for DCV, DCI, Ω2 and Ω4
 ±5% for ACV and ACI
 MINimum 0%
 MAXimum ±100%
```

**Query**

```
:NTOLerance? Query noise tolerance
:NTOLerance? DEFault Query *RST default noise tolerance
:NTOLerance? MINimum Query lowest allowable noise tolerance
:NTOLerance? MAXimum Query largest allowable noise tolerance
```

**Description**

Each measurement function (except TEMP and FREQ) can utilize the advanced filter which adds a noise tolerance window to the averaging algorithm. These commands are used to set the noise tolerance level of the advanced filter for the specified function. The :ADVanced[:STATE] commands are used to enable or disable the advanced filter.

The noise tolerance level is expressed as a percent of the last averaged reading. In general, if the noise is within this window, the reading is simply based on the normal averaging algorithm. If a reading is outside this window, then the advanced averaging algorithm is used. See paragraph 2.9.1 for details.

**Program fragment**

```
PRINT #1, "output 16; :volt:dc:aver:adv:ntol 20; ntol?" ' Get noise
 tolerance
PRINT #1, "enter 16" ' Get response from
 2002
```

**[[:STATE] <b>**

```
[[:SENSe[1]]:CURRent:AC:AVERage:ADVanced[:STATE] Control advanced filter for ACI
[:SENSe[1]]:CURRent:DC:AVERage:ADVanced[:STATE] Control advanced filter for DCI
[:SENSe[1]]:VOLTage:AC:AVERage:ADVanced[:STATE] Control advanced filter for ACV
[:SENSe[1]]:VOLTage:DC:AVERage:ADVanced[:STATE] Control advanced filter for DCV
[:SENSe[1]]:RESistance:AVERage:ADVanced[:STATE] Control advanced filter for Ω2
[:SENSe[1]]:FREStance:AVERage:ADVanced[:STATE] Control advanced filter for Ω4
```

**Parameters**

```
 = 0 or OFF Disable advanced filter
 1 or ON Enable advanced filter
```

**Query**

```
[[:STATE]? Query state of advanced filter
```

**Description**

These commands are used to enable or disable the advanced filter for the specified function. The :ADVanced:NTOLerance commands are used to set tolerance levels.

**Program fragment**

```
PRINT #1, "output 16; :volt:dc:aver:adv on; adv?" ' Enable advanced filter
PRINT #1, "enter 16" ' Get response from 2002
```

**:DETECTOR commands****3.18.12****[[:FUNCTION] <name>**

```
[[:SENSe[1]]:CURRent:AC:DETEctor[:FUNCTION] <name> Specify detector for ACI
[:SENSe[1]]:VOLTage:AC:DETEctor[:FUNCTION] <name> Specify detector for ACV
```

**Parameters**

ACI:

```
<name> = RMS AC RMS amps measurements
 AVERage AC average amps measurements
```

ACV:

```
<name> = RMS AC RMS volts measurements
 AVERage AC average volts measurements
 LFRMs Low frequency AC volts measurements
 PEAK AC peak volts measurements
 NPEak AC negative peak spike volts measurements
 PPEak AC positive peak spike volts measurements
```

**Query**

```
[[:FUNCTION]? Query selected measurement type
```

**Description**

These commands are used to select the measurement type for the ACI and ACV functions. Refer to paragraphs 2.4.1 (ACV) and 2.4.2 (ACI) for details on AC-TYPE.

**Program fragment**

```
PRINT #1, "output 16; :curr:ac:det aver; det?" ' Select average detector
PRINT #1, "enter 16" ' Get response from 2002
```



**3.18.13 :PWINdow <n>**

[:SENSe[1]]:VOLTage:AC:DETEctor:PWINdow &lt;n&gt; Set peak detection window for ACV

**Parameters**

<n> = 0.1 to 9.9 Peak spike detection window (in seconds)  
 DEFault 0.1sec window  
 MINimum 0.1sec window  
 MAXimum 9.9sec window

**Query**

:PWINdow? Query spike detection window  
 :PWINdow? DEFault Query \*RST default window  
 :PWINdow? MINimum Query lowest allowable window  
 :PWINdow? MAXimum Query largest allowable window

**Description**

This command is used to set the detection window for peak spike measurements (:NPEak or :PPEak). The instrument measures and displays the largest peak spike that occurs within each specified detection window. For example, for a second window, the instrument displays the peak spike after every second. See paragraph 2.4.1 (AC-TYPE; Positive Peak and Negative Peak) for more information.

**Program fragment**

```
PRINT #1, "output 16; :volt:ac:det:pwin 1; pwin?" ' Specify 1 sec window
PRINT #1, "enter 16" ' Get response from 2002
```

**3.18.14 :METHod <name>**

[:SENSe[1]]:CURRent:DC:METHod &lt;name&gt; Specify measurement technique for DCI.

**Parameters**

<name> = NORMAL Normal DCI measurement technique  
 ICIRcuit In-circuit DCI measurement technique

**Query**

:METHod? Query measurement technique

**Description**

This command is used to select the DCI measurement technique. NORMAl is used to make conventional current measurements which are performed by breaking the circuit and placing the ammeter in series with it.

The ICIRcuit selection allows you make an in-circuit current measurement of a wire or circuit board trace. This measurement technique is performed by making four-wire INPUT connections to the wire or trace (the AMPS input is not used). The instrument automatically performs a four-wire ohms offset compensated measurement and calculates the current. See paragraph 2.4.2 (IN-CIRCUIT) for details.

**Program fragment**

```
PRINT #1, "output 16; :curr:dc:meth icir; meth?" ' Select in-circuit I
PRINT #1, "enter 16" ' Get response from 2002
```

**3.18.15 :SOURce <name>**

[:SENSe[1]]:FREQuency:SOURce &lt;name&gt; Specify input source for FREQ.

**Parameters**

<name> = CURRent Select current frequency input source  
 VOLTage Select voltage frequency input source

**Query**

:SOURce? Query frequency input source

**Description**

This command is used to select the input source for the signal to be measured. If connecting a current signal to the Model 2002 (AMPS and LO INPUT terminals), select the CURRent input source. If connecting a voltage signal (HI and LO INPUT terminals), select the VOLTage input source.

**Program fragment**

```
PRINT #1, "output 16; :freq:sour curr; sour?" ' Select current input source
PRINT #1, "enter 16" ' Get response from 2002
```

**3.18.16 THReshold commands**

Use these commands to set the maximum signal level and the trigger level for frequency measurements.

**:RANGe <n>**

```
[:SENSe[1]]:FREQUency:THReshold:CURRent:RANGe <n> Set current threshold range
[:SENSe[1]]:FREQUency:THReshold:VOLTage:RANGe <n> Set voltage threshold range
```

**Parameters**

|              |                                                                                               |
|--------------|-----------------------------------------------------------------------------------------------|
| <n> = 0 to 1 | Specify signal level in amps (current threshold)                                              |
| 0 to 1000    | Specify signal level in volts (voltage threshold)                                             |
| DEFAult      | 1mA maximum signal level (current threshold)<br>10V maximum signal level (voltage threshold)  |
| MINimum      | 1mA maximum signal level (current threshold)<br>1V maximum signal level (voltage threshold)   |
| MAXimum      | 1A maximum signal level (current threshold)<br>1000V maximum signal level (voltage threshold) |

**Query**

|                 |                                          |
|-----------------|------------------------------------------|
| :RANGe?         | Query maximum signal level               |
| :RANGe? DEFAult | Query *RST default signal level          |
| :RANGe? MINimum | Query the lowest allowable signal level  |
| :RANGe? MAXimum | Query the largest allowable signal level |

**Description**

These commands are used to specify the expected input level. The instrument will then automatically select the most sensitive current or voltage threshold range. For example, if you specify the expected input current to be 20mA, the instrument selects the 100mA current threshold range.

**Program fragment**

```
PRINT #1, "output 16; :freq:thr:curr:rang .15; range?" ' Select I threshold range
PRINT #1, "enter 16" ' Get response from 2002
```

**:LEVel <n>**

```
[:SENSe[1]]:FREQUency:THReshold:CURRent:LEVel <n> Set current threshold level
[:SENSe[1]]:FREQUency:THReshold:VOLTage:LEVel <n> Set voltage threshold level
```

**Parameters**

Current Threshold:

|                          |                                |
|--------------------------|--------------------------------|
| <n> = -0.0006 to +0.0006 | Trigger level for 1mA range    |
| -0.006 to +0.006         | Trigger level for 10mA range   |
| -0.06 to +0.06           | Trigger level for 100mA range  |
| -0.6 to +0.6             | Trigger level for 1A range     |
| DEFAult                  | 0A trigger level               |
| MINimum                  | Range dependent as shown above |
| MAXimum                  | Range dependent as shown above |

**Voltage Threshold:**

|                    |                                |
|--------------------|--------------------------------|
| <n> = -0.6 to +0.6 | Trigger level for 1V range     |
| -6 to +6           | Trigger level for 10V range    |
| -60 to +60         | Trigger level for 100V range   |
| -600 to +600       | Trigger level for 1000V range  |
| DEFAult            | 0V trigger level               |
| MINimum            | Range dependent as shown above |
| MAXimum            | Range dependent as shown above |

|              |                 |                                       |
|--------------|-----------------|---------------------------------------|
| <b>Query</b> | :LEVel?         | Query trigger level                   |
|              | :LEVel? DEFAult | Query *RST default trigger level      |
|              | :LEVel? MINimum | Query lowest allowable trigger level  |
|              | :LEVel? MAXimum | Query largest allowable trigger level |

**Description**

These commands are used to specify trigger levels for the specified (current or voltage) input signal. An appropriate trigger level is necessary in order for the frequency counter to operate properly. The instrument only counts cycles whose peak signal amplitude reaches the programmed trigger level. See paragraph 2.4.4 (Trigger Level) for more information.

**Program fragment**

```
PRINT #1, "output 16; freq:thr:curr:rang .01" ' Select threshold range
PRINT #1, "output 16; freq:thr:curr:lev .005; lev?" ' Set trigger level
PRINT #1, "enter 16" ' Get response from 2002
```

**:TTL**

```
[[:SENSe[1]]:FREQuency:THReshold:VOLTage:TTL Select TTL trigger level
```

**Description**

This action command is used to configure the voltage trigger level for a TTL input signal. After this command is sent, the 10V threshold voltage range is selected and a threshold trigger level of 0.8V is established.

**Program fragment**

```
PRINT #1, "output 16; freq:thr:curr:volt:t1" ' Select TTL threshold
PRINT #1, "output 16; freq:thr:volt:rang?; lev?" ' Query threshold range and
 trigger level
PRINT #1, "enter 16" ' Get response from 2002
```

**3.18.17****:TRANsducer <name>**

```
[[:SENSe[1]]:TEMPerature:TRANsducer <name> Specify transducer type
```

**Parameters**

|              |                                           |
|--------------|-------------------------------------------|
| <name> = RTD | Two-wire RTD transducer                   |
| FRTD         | Four-wire (and three-wire) RTD transducer |
| TCouple      | Thermocouple transducer                   |
| DTC          | Differential thermocouple transducer      |
| INTernal     | Internal transducer                       |

|              |              |                       |
|--------------|--------------|-----------------------|
| <b>Query</b> | :TRANsducer? | Query transducer type |
|--------------|--------------|-----------------------|

**Description**

This command is used to program the instrument for the transducer type that you are using. If using a two-wire RTD transducer, select RTD. If using a three-wire or four-wire RTD, select FRTD. If using a thermocouple, select TCouple. Select DTC if performing differential TC temperature measurements using the Model 1801 Nanovolt Preamp.

Use the INTernal transducer to measure the internal temperature difference from the calibration temperature of the Model 2002.

**Program fragment**

```
PRINT #1, "output 16; temp:tran int" ' Select the internal transducer
PRINT #1, "output 16; func 'temp'" ' Select the TEMP function
```

**3.18.18 :RTD commands**

See paragraph 2.4.5 for detailed information on making temperature measurements.

**:TYPE <name>**

[[:SENSe[1]]]:TEMPerature:RTD:TYPE <name> Set RTD parameters

**Parameters**

<name> = PT100 Selects default parameters for the PT100 type (ITS-90)  
 D100 Selects default parameters for the D100 type (ITS-90)  
 F100 Selects default parameters for the F100 type (ITS-90)  
 PT385 Selects default parameters for the PT385 type (ITS-68)  
 PT3916 Selects default parameters for the PT3916 type (ITS-68)  
 USER Selects user-defined parameters  
 SPRTD Selects SPRTD type

**Query**

:TYPE? Query RTD type

**Description**

This command is used to select the RTD standard and the other related factors. When one of the parameters other than USER is selected, the instrument defaults to the following RTD factors:

| Standard | Type   | Alpha    | Beta    | Delta   | RZero<br>$\Omega$ at 0°C |
|----------|--------|----------|---------|---------|--------------------------|
| ITS-90   | PT100  | 0.003850 | 0.10863 | 1.49990 | 100 $\Omega$             |
| ITS-90   | D100   | 0.003920 | 0.10630 | 1.49710 | 100 $\Omega$             |
| ITS-90   | F100   | 0.003900 | 0.11000 | 1.49589 | 100 $\Omega$             |
| IPTS-68  | PT385  | 0.003850 | 0.11100 | 1.50700 | 100 $\Omega$             |
| IPTS-68  | PT3916 | 0.003916 | 0.11600 | 1.50594 | 100 $\Omega$             |

Changing Alpha (see :ALPHA), Beta (see :BETA), Delta (see :DELTA) or  $\Omega$  at 0°C (see :RZERO) automatically changes the Type to USER (:TYPE USER). Thus, once you program the appropriate factors for your RTD, you can later recall that setup by using the :TYPE USER command.

**Program fragment**

```
PRINT #1, "output 16; temp:rtd:type pt385; type?" ' Select standard
PRINT #1, "enter 16" ' Get response from 2002
```

**:ALPHA <NRf>**

[[:SENSe[1]]]:TEMPerature:RTD:ALPHA <NRf> Specify Alpha value

**Parameters**

<NRf> = 0 to 0.01 Specify RTD Alpha value

**Query**

:ALPHA? Query the Alpha value

**Description**

This command is used to check and/or change the Alpha value. Keep in mind that changing the current Alpha value changes the Type to USER (see :RTD:TYPE).

**Program fragment**

```
PRINT #1, "output 16; temp:rtd:alpha .0035; alph?" ' Specify alpha value
PRINT #1, "enter 16" ' Get response from 2002
```

**:BETA <NRf>**

[:SENSe[1]]:TEMPerature:RTD:BETA &lt;NRf&gt; Specify Beta value

**Parameters** <NRf> = 0 to 1 Specify RTD Beta value**Query** :BETA? Query the Beta value**Description** This command is used to check and/or change the Beta value. Keep in mind that changing the current Beta value changes the Type to USER (see :RTD:TYPE).**Program fragment**  
PRINT #1, "output 16; temp:rtd:beta .11; beta?" ' Specify beta value  
PRINT #1, "enter 16" ' Get response from 2002**:DELTA <NRf>**

[:SENSe[1]]:TEMPerature:RTD:DELTA &lt;NRf&gt; Specify Delta value

**Parameters** <NRf> = 0 to 5 Specify RTD Delta value**Query** :DELTA? Query the Delta value**Description** This command is used to check and/or change the Delta value. Keep in mind that changing the current Delta value changes the Type to USER (see :RTD:TYPE).**Program fragment**  
PRINT #1, "output 16; temp:rtd:delt 1.75; delt?" ' Specify delta value  
PRINT #1, "enter 16" ' Get response from 2002**:RZERo <NRf>**

[:SENSe[1]]:TEMPerature:RTD:RZERo &lt;NRf&gt; Specify resistance at 0°C

**Parameters** <NRf> = 0 to 10000 Specify RTD Resistance at 0°C (in ohms)**Query** :RZERo? Query RTD resistance at 0°C**Description** This command is used to check and/or change the Resistance at 0°C. Keep in mind that changing the current resistance value changes the Type to USER (see :RTD:TYPE).**Program fragment**  
PRINT #1, "output 16; temp:rtd:rzer 200; rzer?" ' Specify RZero value  
PRINT #1, "enter 16" ' Get response from 2002**:SPRTD commands**

[:SENSe[1]]:TEMPerature:SPRTD:RZERo &lt;NRf&gt;

[:SENSe[1]]:TEMPerature:SPRTD:A4 &lt;NRf&gt;

[:SENSe[1]]:TEMPerature:SPRTD:B4 &lt;NRf&gt;

[:SENSe[1]]:TEMPerature:SPRTD:A7 &lt;NRf&gt;

[:SENSe[1]]:TEMPerature:SPRTD:B7 &lt;NRf&gt;

[:SENSe[1]]:TEMPerature:SPRTD:C7 &lt;NRf&gt;

**Parameters** :RZERo <NRf> Set RTD 0°C resistance value

:A4 &lt;NRf&gt; Set A4 coefficient

:B4 &lt;NRf&gt; Set B4 coefficient

:A7 &lt;NRf&gt; Set A7 coefficient

:B7 &lt;NRf&gt; Set B7 coefficient

:C7 &lt;NRf&gt; Set C7 coefficient

**Query** :RZERo? Query RTD 0°C resistance value

:A4? Query A4 coefficient

:B4? Query B4 coefficient

:A7? Query A7 coefficient

:B7? Query B7 coefficient

:C7? Query C7 coefficient

**Description**

These commands program the various parameters for SPRTD (Standard Platinum Resistance Thermometers). A single SPRTD, however, usually cannot be used to cover the entire range, so the temperature range is broken up into several subranges. An SPRTD is supplied with a certificate of calibration that lists the calibration constants and the temperature range supported. In most cases, the supplied coefficients must be translated into Model 2002 values as summarized in the table below. See paragraph 2.4.5 in Section 2 for more information.

| <b>Coefficients</b>                | <b>RTD coefficients to Model 2002 coefficients</b>                                                                                |
|------------------------------------|-----------------------------------------------------------------------------------------------------------------------------------|
| Subrange #1: 13.8033K - 273.16K    | Not applicable                                                                                                                    |
| Subrange #2: 24.5561K - 273.16K    | A2 to A4, B2 to B4                                                                                                                |
| Subrange #3: 54.3584K - 273.16K    | A3 to A4, B3 to B4                                                                                                                |
| Subrange #4: 83.8058K - 273.16K    | No substitution needed                                                                                                            |
| Subrange #5: 234.3156K - 302.9146K | A5 to A4, A5 to A7, B5 to B4<br>B5 to B7, Set C7 = 0. A5 value entered for both<br>A4 and A7; B5 value entered for both B4 and B7 |
| Subrange #6: 273.15K - 1234.93K    | Not applicable                                                                                                                    |
| Subrange #7: 273.15K - 933.473K    | No substitution needed                                                                                                            |
| Subrange #8: 273.15K - 692.677K    | A8 to A7, B8 to B7, Set C7 = 0                                                                                                    |
| Subrange #9: 273.15K - 505.078K    | A9 to A7, B9 to B7, Set C7 = 0                                                                                                    |
| Subrange #10: 273.15K - 429.7485K  | A10 to A7, B10 to B7, Set C7 = 0                                                                                                  |
| Subrange #11: 273.15K - 302.9146K  | A11 to A7, Set B7 = 0, C7 = 0                                                                                                     |

**Example**

Suppose you are using an SPRTD that has been calibrated for subrange #2 above that is calibrated for measurements between 24.5561 and 273.16K. The Model 2002, however, supports only SPRTD temperatures down to 83.805K, so temperatures below this value will be reported as an overflow even though the SPRTD is capable of measuring lower. The calibration certificate lists A2, B2, C1, C2, and C3 as the calibration coefficients. You can set up the Model 2002 for this measurement as follows:

1. Set the temperature sensor type to FRTD (4-wire measurement) by sending:  
:SENS1:TEMP:TRAN FRTD
2. Choose the RTD type as SPRTD:  
:SENS1:TEMP:RTD:TYPE SPRTD
3. Set the RTD sensor 0°C resistance value:  
:SENS1:TEMP:RTD:SPRTD:RZER <R\_zero>
4. Set the A4 coefficient to the RTD certificate value for A2:  
:SENS1:TEMP:SPRTD:A4 <certificate\_A2\_value >
5. Set the B4 coefficient to the RTD certificate value for B2:  
:SENS1:TEMP:SPRTD:B4 <certificate\_B2\_value >

Note that the A7, B7, and C7 values will not be used for this sensor.

6. Change to the temperature function, and begin taking readings.

**3.18.19****:TCouple:TYPE <name>**

[ :SENSe[1]]:TEMPerature:TCouple:TYPE <name> Specify TC type

**Parameters**

<name> = J Set operation for Type J thermocouples  
 T Set operation for Type T thermocouples  
 K Set operation for Type K thermocouples  
 E Set operation for Type E thermocouples  
 R Set operation for Type R thermocouples

S Set operation for Type S thermocouples  
 B Set operation for Type B thermocouples  
 N Set operation for Type N thermocouples

**Query** :TYPE? Query thermocouple type

**Description** This command is used to configure the Model 2002 for the thermocouple type that you are using to make temperature measurements. See paragraph 2.4.5 (SENSOR) for more information.

**Program fragment**

```
PRINT #1, "output 16; temp:tc:type k; type?" ' Specify TC type
PRINT #1, "enter 16" ' Get response from 2002
```

### 3.18.20 :RJUNCTIONX commands

Where; X = 1 to 5 to specify reference junction.

These commands are used to configure the specified reference junction for thermocouple temperature measurements. Typically, each thermocouple switching card uses a single reference junction. See paragraph 2.4.5 (REF-JUNCTIONS) for more information

#### :RSElect <name>

[:SENSe[1]]:TEMPerature:RJUNCTIONX:RSElect <name> Specify reference junction type.

**Parameters**

|          |           |                                         |
|----------|-----------|-----------------------------------------|
| <name> = | SIMulated | Use simulated temperature as reference  |
|          | REAL      | Use a measured temperature as reference |

**Query** :RSElect? Query reference junction type

**Description** This command is used to specify the type of reference junction that is going to be used for thermocouple temperature measurements. Specify REAL if using an actual reference junction. The :REAL:TCoefficient command is then used to specify the temperature coefficient of the reference junction.

Specify SIMulated if you wish to use a simulated reference temperature. The :SIMulated command is then used to specify the desired simulated reference temperature.

**Program fragment**

```
PRINT #1, "output 16; temp:rjun1:rsel sim; rsel?" ' Specify reference
PRINT #1, "enter 16" ' Get response from 2002
```

#### :SIMulated <n>

[:SENSe[1]]:TEMPerature:RJUNCTIONX:SIMulated <n> Specify simulated reference temperature

**Parameters**

|       |            |                           |
|-------|------------|---------------------------|
| <n> = | 0 to 50    | Specify temperature in °C |
|       | 32 to 122  | Specify temperature in °F |
|       | 273 to 323 | Specify temperature in K  |
|       | DEFault    | 23°C, 73°F, 296K          |
|       | MINimum    | 0°C, 32°F, 273K           |
|       | MAXimum    | 50°C, 122°F, 323K         |

**Query**

|                     |                                   |
|---------------------|-----------------------------------|
| :SIMulated?         | Query simulated reference         |
| :SIMulated? DEFault | Query default *RST reference      |
| :SIMulated? MINimum | Query lowest allowable reference  |
| :SIMulated? MAXimum | Query largest allowable reference |

**Description** This command is used to specify the simulated reference temperature. The temperature value depends on which temperature scale is currently selected (°C, °F or K). Typically, 0° or 23°C is used as the simulated reference temperature.

The :ACQUIRE command is then used to store the simulated reference temperature.

**Program fragment**

```
PRINT #1, "output 16; :unit:temp c" ' Select °C temp scale
PRINT #1, "output 16; temp:rjun1:sim 0; sim?" ' Set reference for 0°C
PRINT #1, "enter 16" ' Get response from 2002
```

**:TCoefficient <n>**

[ :SENSe[1]]:TEMPerature:RJNctionX:REAL:TCoefficient <n> Specify temperature coefficient

**Parameters**

|         |                      |                                  |
|---------|----------------------|----------------------------------|
| <n> =   | -0.09999 to +0.09999 | Specify temperature coefficient  |
| Default |                      | +0.01 temperature coefficient    |
| MINimum |                      | -0.09999 temperature coefficient |
| MAXimum |                      | +0.09999 temperature coefficient |

**Query**

|                        |  |                                    |
|------------------------|--|------------------------------------|
| :TCoefficient?         |  | Query temperature coefficient (TC) |
| :TCoefficient? Default |  | Query *RST default TC              |
| :TCoefficient? MINimum |  | Query lowest allowable TC          |
| :TCoefficient? MAXimum |  | Query largest allowable TC         |

**Description**

This command is used to specify the temperature coefficient (TC) of the “real” temperature reference junction. TC is specified in °C/volt and is not affected by the :UNIT :TEMPerature command. The :ACQUIRE command can then be used to acquire the reference temperature.

**Program fragment**

```
PRINT #1, "output 16; temp:rjun1:real:tco .05; tco?" ' Set temp coefficient
PRINT #1, "enter 16" ' Get response from 2002
```

**:OFFSet <n>**

[ :SENSe[1]]:TEMPerature:RJNctionX:REAL:OFFSet <n> Specify voltage offset

**Parameters**

|         |                      |                               |
|---------|----------------------|-------------------------------|
| <n> =   | -0.09999 to +0.09999 | Specify voltage offset at 0°C |
| Default |                      | 0.01V offset                  |
| MINimum |                      | -0.09999V offset              |
| MAXimum |                      | +0.09999V offset              |

**Query**

|                  |  |                                        |
|------------------|--|----------------------------------------|
| :OFFSet?         |  | Query voltage offset                   |
| :OFFSet? Default |  | Query *RST default voltage offset      |
| :OFFSet? MINimum |  | Query lowest allowable voltage offset  |
| :OFFSet? MAXimum |  | Query largest allowable voltage offset |

**Description**

This command is used to specify the offset voltage at 0°C for the specified reference junction.

**Program fragment**

```
PRINT #1, "output 16; temp:rjun1:real:offs .05; offs?" ' Set voltage offset
PRINT #1, "enter 16" ' Get response from 2002
```

**:ACQUIRE**

[ :SENSe[1]]:TEMPerature:RJNctionX:ACQUIRE Update reference temperature

**Description**

This action command is used to update the stored reference temperature (Simulated or Real) for generating a temperature measurement.

**Program fragment**

```
PRINT #1, "output 16; ":temp:rjun1:acq" ' Update reference temperature
```



**3.18.21 :OCOMpensated <b>**

[ :SENSe[1] ]:RESistance:OCOMpensated <b> Control offset compensation for  $\Omega 2$   
 [ :SENSe[1] ]:FREStance:OCOMpensated <b> Control offset compensation for  $\Omega 4$

**Parameters**

<b> = 0 or OFF Disable offset compensated ohms  
 1 or ON Enable offset compensated ohms

**Query**

:OCOMpensated? Query state of offset compensated ohms

**Description**

This command is used to enable or disable the offset compensated ohms feature. Offset compensation is used to cancel the effects of offset voltages (such as thermal EMFs) when making resistance measurements. Offset compensation is explained in detail in paragraph 2.4.3 (OFF-SETCOMP).

**Program fragment**

```
PRINT #1, "output 16; :res:ocom on; ocom?" ' Enable offset compensation
PRINT #1, "enter 16" ' Get response from 2002
```

**3.18.22 :DTCouple commands**

The following commands are used to make differential thermocouple temperature measurements using the Model 1801 Nanovolt Preamp. Refer to the instruction manual for the Model 1801 for details.

**:TYPE <type>**

[ :SENSe[1] ]:TEMPerature:DTCouple:TYPE <type> Set thermocouple type

**Parameters**

<type> = J Set operation for Type J thermocouple  
 K Set operation for Type K thermocouple  
 T Set operation for Type T thermocouple  
 E Set operation for Type E thermocouple  
 R Set operation for Type R thermocouple  
 S Set operation for Type S thermocouple  
 B Set operation for Type B thermocouple  
 N Set operation for Type N thermocouple  
 USER Select user-defined slope for other type of thermocouples

**Query**

:TYPE? Query DTC type

**Description**

This command is used to set thermocouple type for differential thermocouple measurements using the Model 1801 Nanovolt Preamp. Selecting one of the seven standard thermocouples (J, K, T, E, R, S, B, or N) requires that you specify the reference temperature for the reference thermocouple using the :RTEMperature command.

When using other thermocouple types (USER selected), you must specify the thermocouple slope (coefficient) using the :USLope command.

Refer to the Model 1801 Nanovolt Preamp Instruction manual for details on making differential thermocouple temperature measurements.

**Program fragment**

```
PRINT #1, "output 16; :temp:dtc:type K; type?" ' Select type K TC
PRINT #1, "enter 16" ' Get response from 2002
```

**:USlope <n>**

[:SENSe[1]]:TEMPerature:DTCouple:USlope &lt;n&gt; Set TC slope

**Parameters**

<n> = -0.99999 to 0.99999 Specify TC slope  
 DEFault Set TC slope to 20E-6  
 MINimum Set TC slope to -0.99999  
 MAXimum Set TC slope to 0.99999

**Query**

:USlope? Query TC slope  
 :USlope? DEFault Query \*RST default slope value  
 :USlope? MINimum Query minimum slope value  
 :USlope? MAXimum Query maximum slope value

**Description**

When the USER type thermocouple is selected (see previous command), this command is used to set the slope (coefficient) for the thermocouple or thermopile that you are using.

Refer to the Model 1801 Nanovolt Preamp Instruction manual for details on making differential thermocouple temperature measurements.

**Program fragment**

```
PRINT #1, "output 16; :temp:dtc:usl 10E-6; usl?" ' Set TC slope
PRINT #1, "enter 16" ' Get response from 2002
```

**:RTEMperature <n>**

[:SENSe[1]]:TEMPerature:DTCouple:RTEMperature &lt;n&gt; Specify reference TC temperature

**Parameters**

<n> = -273 to 2000 Specify reference TC temperature in °C  
 DEFault Reference TC 0°C  
 MINimum Reference TC temperature -273°C  
 MAXimum Reference TC temperature 2000°C

**Query**

:RTEMperature? Query reference TC temperature  
 :RTEMperature? DEFault Query \*RST default temperature  
 :RTEMperature? MINimum Query minimum temperature  
 :RTEMperature? MAXimum Query maximum temperature

**Description**

When one of the seven standard thermocouples (J, K, T, E, R, S or B) is selected (see :TYPE command), this command is used to enter the reference temperature at which the reference thermocouple will be operated during measurement.

Refer to the Model 1801 Nanovolt Preamp Instruction manual for details on making differential thermocouple temperature measurements.

**Program fragment**

```
PRINT #1, "output 16; :temp:dtc:rtem 100; rtem?" ' Specify reference temp
PRINT #1, "enter 16" ' Get response from 2002
```

**3.18.23****:SENSe2 subsystem**

This subsystem is used to read the digital I/O port.

**:TTL[1]:DATA?**

[:SENSe2:TTL[1]:DATA? Read input port

**Description**

This command is used to read the single line of the digital input port. A value of "1" indicates that the input port is high (ON), and a value of "0" indicates that the port is low (OFF).

**Program fragment**

```
PRINT #1, "output 16; :sens2:t1:data?" ' Read input port
PRINT #1, "enter 16" ' Get response from 2002
```

### 3.19 :SOURce subsystem

This subsystem is used to set the logic level (true or false) of each digital output line. The commands for this subsystem are summarized in Table 3-11.

#### **[[:LEVEL] <b>**

|                            |                                |
|----------------------------|--------------------------------|
| :SOURce:TTL[1]:[LEVEL] <b> | Control digital output line #1 |
| :SOURce:TTL2:[LEVEL] <b>   | Control digital output line #2 |
| :SOURce:TTL3:[LEVEL] <b>   | Control digital output line #3 |
| :SOURce:TTL4:[LEVEL] <b>   | Control digital output line #4 |

#### **Parameters**

|               |                       |
|---------------|-----------------------|
| <b> = 1 or ON | Set output line true  |
| 0 or OFF      | Set output line false |

#### **Query**

[[:LEVEL]]? Query logic level of specified line

#### **Description**

These commands are used to set the logic levels for the digital output port. The actual level (high or low) of a digital output line depends on its programmed polarity (see Output subsystem). If the polarity of a line is active-high, then that line is high when it is set to be true (1 or ON), and low when it is set to be false (0 or OFF). Conversely, if polarity is active-low, the line is low when it is set to be true, and high when it is set to be false.

#### **NOTE**

If a LIMITS control is enabled (LOLIM1 or 2, HILIM1 or 2—High, Low, or Pass), this command does not check or change the output status. Refer to paragraph 2.12.5 for information on limits.

#### **Program fragment**

```
PRINT #1, "output 16; :sour:t1l on; t1l?" ' Set line #1 true
PRINT #1, "enter 16" ' Get response from 2002
```

## 3.20 :STATus subsystem

The STATus subsystem is used to control the status registers of the Model 2002. These registers and the overall status structure is explained in paragraph 3.7. The commands in this subsystem are summarized in Table 3-12.

### 3.20.1

#### [:EVENT]?

|                                         |                                  |
|-----------------------------------------|----------------------------------|
| :STATus:MEASurement[:EVENT]?            | Read Measurement Event Register  |
| :STATus:QUeStionable[:EVENT]?           | Read Questionable Event Register |
| :STATus:OPERation[:EVENT]?              | Read Operation Event Register    |
| :STATus:OPERation:TRIGger[:EVENT]?      | Read Trigger Event Register      |
| :STATus:OPERation:ARM[:EVENT]?          | Read Arm Event Register          |
| :STATus:OPERation:ARM:SEQUence[:EVENT]? | Read Sequence Event Register     |

#### Description

These query commands are used to read the event registers. After sending one of these commands and addressing the Model 2002 to talk, a decimal value is sent to the computer. The binary equivalent of this value determines which bits in the appropriate register are set. The event registers are shown in Figures 3-21 through 3-26. Note that reading an event register clears the bits in that register.

For example, assume that reading the Measurement Event Register results in an acquired decimal value of 544. The binary equivalent is 0000001000100000. For this binary value, bits B5 and B9 of the Measurement Event Register are set.

The significance of a set bit in these registers depends on how the transition filter is programmed (see :PTRansition and :NTRansition commands). If an event is programmed for a positive transition (PTR), the corresponding bit in this register sets when the event occurs. If the event is instead programmed for a negative transition (NTR), the bit sets when the event becomes not true.

#### Measurement Event Register:

**Bit B0, Reading Overflow (ROF)** — Set bit indicates that the reading exceeds the measurement range of the instrument (PTR), or the instrument has gone from an overflow condition to a normal reading condition (NTR).

**Bit B1, Low Limit 1 (LL1)** — Set bit indicates that the reading is less than the Low Limit 1 setting (PTR), or that a subsequent reading is no longer less than the Low Limit 1 setting (NTR).

**Bit B2, High Limit 1 (HL1)** — Set bit indicates that the reading is greater than the High Limit 1 setting (PTR), or that a subsequent reading is no longer greater than the High Limit 1 setting (NTR).

**Bit B3, Low Limit 2 (LL2)** — Set bit indicates that the reading is less than the Low Limit 2 setting (PTR), or that a subsequent reading is no longer less than the Low Limit 2 setting (NTR).

**Bit B4, High Limit 2 (HL2)** — Set bit indicates that the reading is greater than the High Limit 2 setting (PTR), or that a subsequent reading is no longer greater than the High Limit 2 setting (NTR).

**Bit B5, Reading Available (RAV)** — Set bit indicates that a reading was taken and processed (PTR), or that a subsequent reading is in process (NTR).

**Bit B6** — Not used.

**Bit B7, Buffer Available (BAV)** — Set bit indicates that there are at least two readings in the trace buffer (PTR), or the buffer has become empty (NTR).

**Bit B8, Buffer Half Full (BHF)** — Set bit indicates that the trace buffer is half full (PTR), or that the buffer is no longer half full (NTR).

**Bit B9, Buffer Full (BFL)** — Set bit indicates that the trace buffer is full (PTR), or that the buffer is no longer full (NTR).

**Bit B10** — Not used.

**Bit B11, Buffer Pretriggered (BPT)** — Set bit indicates that the trace buffer pretrigger event has occurred (PTR), or the operations associated with the pretrigger have been completed (NTR).

**Bits B12 through B15** — Not used.

| Bit Position      | B15 - B12 | B11                        | B10 | B9                       | B8                       | B7                       | B6 | B5                      | B4                      | B3                     | B2                     | B1                     | B0                     |
|-------------------|-----------|----------------------------|-----|--------------------------|--------------------------|--------------------------|----|-------------------------|-------------------------|------------------------|------------------------|------------------------|------------------------|
| Event             | —         | BPT                        | —   | BFL                      | BHF                      | BAV                      | —  | RAV                     | HL2                     | LL2                    | HL1                    | LL1                    | ROF                    |
| Decimal Weighting | —         | 2048<br>(2 <sup>11</sup> ) | —   | 512<br>(2 <sup>9</sup> ) | 256<br>(2 <sup>8</sup> ) | 128<br>(2 <sup>7</sup> ) | —  | 32<br>(2 <sup>5</sup> ) | 16<br>(2 <sup>4</sup> ) | 8<br>(2 <sup>3</sup> ) | 4<br>(2 <sup>2</sup> ) | 2<br>(2 <sup>1</sup> ) | 1<br>(2 <sup>0</sup> ) |
| Value             | —         | 0/1                        | —   | 0/1                      | 0/1                      | 0/1                      | —  | 0/1                     | 0/1                     | 0/1                    | 0/1                    | 0/1                    | 0/1                    |

Value : 1 = Measurement Event Set  
0 = Measurement Event Cleared

Events : BPT = Buffer Pretriggered  
BFL = Buffer Full  
BHF = Buffer Half Full  
BAV = Buffer Available  
RAV = Reading Available  
HL2 = High Limit 2  
LL2 = Low Limit 2  
HL1 = High Limit 1  
LL1 = Low Limit 1  
ROF = Reading Overflow

**Figure 3-21**  
*Measurement Event Register*

**Questionable Event Register:**

**Bits B0 through B3** — Not used.

**Bit B4, Temperature Summary (Temp)** — Set bit indicates that an invalid reference junction measurement has occurred for thermocouple temperature measurements (PTR), or a subsequent valid reference junction measurement has occurred (NTR).

**Bits B5, B6 and B7** — Not used.

**Bit B8, Calibration Summary (Cal)** — Set bit indicates that an invalid calibration constant was detected during the power-up sequence (PTR). The instrument will instead use a default calibration constant. This error will clear after successful calibration of the instrument.

**Bits B9 through B13** — Not used.

**Bit B14, Command Warning (Warn)** — Set bit indicates that a Signal Oriented Measurement Command parameter has been ignored (PTR), or a subsequent Signal Oriented Measurement Command has executed successfully (NTR).

Note: Whenever a questionable event occurs, the ERR annunciator will turn on. The annunciator will turn off when the questionable event clears.

|                   |     |                             |          |                          |         |                         |         |
|-------------------|-----|-----------------------------|----------|--------------------------|---------|-------------------------|---------|
| Bit Position      | B15 | B14                         | B13 - B9 | B8                       | B7 - B5 | B4                      | B3 - B0 |
| Event             | —   | Warn                        | —        | Cal                      | —       | Temp                    | —       |
| Decimal Weighting | —   | 16384<br>(2 <sup>14</sup> ) | —        | 256<br>(2 <sup>8</sup> ) | —       | 16<br>(2 <sup>4</sup> ) | —       |
| Value             | 0   | 0/1                         | —        | 0/1                      | —       | 0/1                     | —       |

Value : 1 = Questionable Event Bit Set  
0 = Questionable Event Bit Cleared

Events : Warn = Command Warning  
Cal = Calibration Summary  
Temp = Temperature Summary

**Figure 3-22**  
*Questionable Event Register*

#### Operation Event Register:

**Bit B0, Calibrating (Cal)** — Set bit indicates that the instrument is calibrating (PTR), or calibration is complete (NTR).

**Bits B1, B2 and B3** — Not used.

**Bits B4 Measuring (Meas)** — Set bit indicates that the instrument is actively measuring (PTR), or the measurement has finished.

**Bit B5, Waiting for Trigger (Trig)** — Set bit indicates that the instrument is waiting in the trigger layer (PTR) of the trigger model, or that it has left the trigger layer (NTR).

**Bit B6, Waiting for Arm (Arm)** — Set bit indicates that the instrument is waiting in an arm layer of the trigger model (PTR), or operation has proceeded from the arm layers into the trigger layer (NTR).

**Bits B7, B8 and B9** — Not used.

**Bit B10, Idle** — Set bit indicates that the instrument is in the idle state (PTR), or has left the idle state to perform an operation (NTR).

**Bits B11 through B15** — Not used.

|                   |           |                            |    |    |    |                         |                         |                         |    |    |    |                        |
|-------------------|-----------|----------------------------|----|----|----|-------------------------|-------------------------|-------------------------|----|----|----|------------------------|
| Bit Position      | B15 - B11 | B10                        | B9 | B8 | B7 | B6                      | B5                      | B4                      | B3 | B2 | B1 | B0                     |
| Event             | —         | Idle                       | —  | —  | —  | Arm                     | Trig                    | Meas                    | —  | —  | —  | Cal                    |
| Decimal Weighting | —         | 1024<br>(2 <sup>10</sup> ) | —  | —  | —  | 64<br>(2 <sup>6</sup> ) | 32<br>(2 <sup>5</sup> ) | 16<br>(2 <sup>4</sup> ) | —  | —  | —  | 1<br>(2 <sup>0</sup> ) |
| Value             | —         | 0/1                        | —  | —  | —  | 0/1                     | 0/1                     | 0/1                     | —  | —  | —  | 0/1                    |

Value : 1 = Operation Event Set  
0 = Operation Event Cleared

Events : Idle = Idle state of the 2002  
Arm = Waiting for Arm  
Trig = Waiting for Trigger  
Meas = Measuring  
Cal = Calibrating

**Figure 3-23**  
*Operation Event Register*

**Trigger Event Register:**

**Bit B0** — Not used.

**Bit B1, Sequence 1 (Seq1)** — Set bit indicates that the instrument is in the trigger layer (PTR), or that the instrument has exited from the trigger layer (NTR).

**Bits B2 through B15** — Not used.

|                   |          |                        |    |
|-------------------|----------|------------------------|----|
| Bit Position      | B15 - B2 | B1                     | B0 |
| Event             | —        | Seq1                   | —  |
| Decimal Weighting | —        | 2<br>(2 <sup>1</sup> ) | —  |
| Value             | —        | 0/1                    | —  |

Value : 1 = Event Bit Set  
0 = Event Bit Cleared

Event : Seq1 = Sequence 1

**Figure 3-24**  
*Trigger Event Register*

**Arm Event Register:**

**Bit B0** — Not used.

**Bit B1, Sequence 1 (Seq1)** — Set bit indicates that the instrument is in an arm layer (PTR), or that the instrument has exited from the arm layers (NTR).

**Bits B2 through B15** — Not used.

|                   |          |                        |    |
|-------------------|----------|------------------------|----|
| Bit Position      | B15 - B2 | B1                     | B0 |
| Event             | —        | Seq1                   | —  |
| Decimal Weighting | —        | 2<br>(2 <sup>1</sup> ) | —  |
| Value             | —        | 0/1                    | —  |

Value : 1 = Event Bit Set      Event : Seq1 = Sequence 1  
 0 = Event Bit Cleared

**Figure 3-25**  
*Arm Event Register*

**Sequence Event Register:**

**Bit B0** — Not used.

**Bit B1, Layer 1 (Lay1)** — Set bit indicates that instrument operation is in arm layer 1 (PTR), or that operation has exited from arm layer 1 NTR).

**Bit B2, Layer 2 (Lay2)** — Set bit indicates that instrument operation is in arm layer 2 (PTR), or that operation has exited from arm layer 2 NTR).

**Bits B3 through B15** — Not used.

**Program fragment**

```
PRINT #1, "output 16; :stat:meas?" ' Query Measure Event Register
PRINT #1, "enter 16" ' Get response from 2002
```

|                   |          |                        |                        |    |
|-------------------|----------|------------------------|------------------------|----|
| Bit Position      | B15 - B3 | B2                     | B1                     | B0 |
| Event             | —        | Lay2                   | Lay1                   | —  |
| Decimal Weighting | —        | 4<br>(2 <sup>2</sup> ) | 2<br>(2 <sup>1</sup> ) | —  |
| Value             | —        | 0/1                    | 0/1                    | —  |

Value : 1 = Event Bit Set      Event : Lay1 = Layer 1  
 0 = Event Bit Cleared          Lay2 = Layer 2

**Figure 3-26**  
*Sequence Event Register*



## 3.20.2

**:ENABLE <NRf>**

|                                             |                                            |
|---------------------------------------------|--------------------------------------------|
| :STATus:MEASurement:ENABle <NRf>            | Program Measurement Event Enable Register  |
| :STATus:QUEStionable:ENABle <NRf>           | Program Questionable Event Enable Register |
| :STATus:OPERation:ENABle <NRf>              | Program Operation Event Enable Register    |
| :STATus:OPERation:TRIGger:ENABle <NRf>      | Program Trigger Event Enable Register      |
| :STATus:OPERation:ARM:ENABle <NRf>          | Program Arm Event Enable Register          |
| :STATus:OPERation:ARM:SEQUence:ENABle <NRf> | Program Sequence Event Enable Register     |

**Parameters**

|           |                |             |              |
|-----------|----------------|-------------|--------------|
| <NRf> = 0 | Clear register | <NRf> = 128 | Set bit B7   |
| 1         | Set bit B0     | 256         | Set bit B8   |
| 2         | Set bit B1     | 512         | Set bit B9   |
| 4         | Set bit B2     | 1024        | Set bit B10  |
| 8         | Set bit B3     | 2048        | Set bit B11  |
| 16        | Set bit B4     | 16384       | Set bit B14  |
| 32        | Set bit B5     | 65535       | Set all bits |
| 64        | Set bit B6     |             |              |

**Query**

:ENABle? Query enable register

**Description**

These commands are used to set the contents of the event enable registers (see Figures 3-27 through 3-32). An :ENABle command is sent with the decimal equivalent of the binary value that determines the desired state (0 or 1) of each bit in the appropriate register.

Each event enable register is used as a mask for events (see [:EVENT] for descriptions of events). When a bit in an event enable register is cleared (0), the corresponding bit in the event register is masked and thus, cannot set the corresponding summary bit of the next register set in the status structure. Conversely, when a bit in an event enable register is set (1), the corresponding bit in the event register is unmasked. When the unmasked bit in the event register sets, the summary bit of the next register set in the status structure will set.

The decimal weighting of the bits for each event enable register are included in Figures 3-27 through 3-32. The sum of the decimal weights of the bits that you wish to set is sent as the parameter (<NRf>) for the appropriate :ENABle command. For example, to set the BFL and RAV bits of the Measurement Event Enable Register, send the following command:

```
:stat:meas:enab 544
```

|                               |   |     |
|-------------------------------|---|-----|
| where; BFL (bit B9) = Decimal | = | 512 |
| RAV (bit B5) = Decimal        | = | 32  |
| <NRf> =                       | = | 544 |

**Program fragment**

```
PRINT #1, "output 16; :stat:oper:enab 514; enab?" ' Set B1 and B9 of Op Enable Register and query
PRINT #1, "enter 16" ' Get response message from 2002
```

|                   |           |                            |     |                          |                          |                          |    |                         |                         |                        |                        |                        |                        |
|-------------------|-----------|----------------------------|-----|--------------------------|--------------------------|--------------------------|----|-------------------------|-------------------------|------------------------|------------------------|------------------------|------------------------|
| Bit Position      | B15 - B12 | B11                        | B10 | B9                       | B8                       | B7                       | B6 | B5                      | B4                      | B3                     | B2                     | B1                     | B0                     |
| Event             | —         | BPT                        | —   | BFL                      | BHF                      | BAV                      | —  | RAV                     | HL2                     | LL2                    | HL1                    | LL1                    | ROF                    |
| Decimal Weighting | —         | 2048<br>(2 <sup>11</sup> ) | —   | 512<br>(2 <sup>9</sup> ) | 256<br>(2 <sup>8</sup> ) | 128<br>(2 <sup>7</sup> ) | —  | 32<br>(2 <sup>5</sup> ) | 16<br>(2 <sup>4</sup> ) | 8<br>(2 <sup>3</sup> ) | 4<br>(2 <sup>2</sup> ) | 2<br>(2 <sup>1</sup> ) | 1<br>(2 <sup>0</sup> ) |
| Value             | —         | 0/1                        | —   | 0/1                      | 0/1                      | 0/1                      | —  | 0/1                     | 0/1                     | 0/1                    | 0/1                    | 0/1                    | 0/1                    |

Value : 1 = Enable Measurement Event  
 0 = Disable (Mask) Measurement Event

Events : BPT = Buffer Pretriggered  
 BFL = Buffer Full  
 BHF = Buffer Half Full  
 BAV = Buffer Available  
 RAV = Reading Available  
 HL2 = High Limit 2  
 LL2 = Low Limit 2  
 HL1 = High Limit 1  
 LL1 = Low Limit 1  
 ROF = Reading Overflow

**Figure 3-27**  
 Measurement Event Enable Register

|                   |     |                             |          |                          |         |                         |         |
|-------------------|-----|-----------------------------|----------|--------------------------|---------|-------------------------|---------|
| Bit Position      | B15 | B14                         | B13 - B9 | B8                       | B7 - B5 | B4                      | B3 - B0 |
| Event             | —   | Warn                        | —        | Cal                      | —       | Temp                    | —       |
| Decimal Weighting | —   | 16384<br>(2 <sup>14</sup> ) | —        | 256<br>(2 <sup>8</sup> ) | —       | 16<br>(2 <sup>4</sup> ) | —       |
| Value             | 0   | 0/1                         | —        | 0/1                      | —       | 0/1                     | —       |

Value : 1 = Enable Questionable Event  
 0 = Disable (Mask) Questionable Event

Events : Warn = Command Warning  
 Cal = Calibration Summary  
 Temp = Temperature Summary

**Figure 3-28**  
 Questionable Event Enable Register

|                   |           |                            |    |    |    |                         |                         |    |    |    |                        |                        |
|-------------------|-----------|----------------------------|----|----|----|-------------------------|-------------------------|----|----|----|------------------------|------------------------|
| Bit Position      | B15 - B11 | B10                        | B9 | B8 | B7 | B6                      | B5                      | B4 | B3 | B2 | B1                     | B0                     |
| Event             | —         | Idle                       | —  | —  | —  | Arm                     | Trig                    | —  | —  | —  | Set                    | Cal                    |
| Decimal Weighting | —         | 1024<br>(2 <sup>10</sup> ) | —  | —  | —  | 64<br>(2 <sup>6</sup> ) | 32<br>(2 <sup>5</sup> ) | —  | —  | —  | 2<br>(2 <sup>1</sup> ) | 1<br>(2 <sup>0</sup> ) |
| Value             | —         | 0/1                        | —  | —  | —  | 0/1                     | 0/1                     | —  | —  | —  | 0/1                    | 0/1                    |

Value : 1 = Enable Operation Event  
 0 = Disable (Mask) Operation Event

Events : Idle = Idle state of the 2002  
 Arm = Waiting for Arm  
 Trig = Waiting for Trigger  
 Set = Settling  
 Cal = Calibrating

**Figure 3-29**  
 Operation Event Enable Register

|                   |          |                        |    |
|-------------------|----------|------------------------|----|
| Bit Position      | B15 - B2 | B1                     | B0 |
| Event             | —        | Seq1                   | —  |
| Decimal Weighting | —        | 2<br>(2 <sup>1</sup> ) | —  |
| Value             | —        | 0/1                    | —  |

Value : 1 = Enable Trigger Event  
 0 = Disable (Mask) Trigger Event

Event : Seq1 = Sequence 1

**Figure 3-30**  
 Trigger Event Enable Register

|                   |          |                        |    |
|-------------------|----------|------------------------|----|
| Bit Position      | B15 - B2 | B1                     | B0 |
| Event             | —        | Seq1                   | —  |
| Decimal Weighting | —        | 2<br>(2 <sup>1</sup> ) | —  |
| Value             | —        | 0/1                    | —  |

Value : 1 = Enable Arm Event  
 0 = Disable (Mask) Arm Event

Event : Seq1 = Sequence 1

**Figure 3-31**  
 Arm Event Enable Register

|                   |          |                        |                        |    |
|-------------------|----------|------------------------|------------------------|----|
| Bit Position      | B15 - B3 | B2                     | B1                     | B0 |
| Event             | —        | Lay2                   | Lay1                   | —  |
| Decimal Weighting | —        | 4<br>(2 <sup>2</sup> ) | 2<br>(2 <sup>1</sup> ) | —  |
| Value             | —        | 0/1                    | 0/1                    | —  |

Value : 1 = Enable Sequence Event  
0 = Disable (Mask) Sequence Event

Events : Lay1 = Layer 1  
Lay2 = Layer 2

**Figure 3-32**  
*Sequence Event Enable Register*

### 3.20.3

#### **:PTRansition <NRf>**

|                                                  |                                              |
|--------------------------------------------------|----------------------------------------------|
| :STATus:MEASurement:PTRansition <NRf>            | Program Measurement Transition Filter (PTR)  |
| :STATus:QUEStionable:PTRansition <NRf>           | Program Questionable Transition Filter (PTR) |
| :STATus:OPERation:PTRansition <NRf>              | Program Operation Transition Filter (PTR)    |
| :STATus:OPERation:TRIGger:PTRansition <NRf>      | Program Trigger Transition Filter (PTR)      |
| :STATus:OPERation:ARM:PTRansition <NRf>          | Program Arm Transition Filter (PTR)          |
| :STATus:OPERation:ARM:SEQUence:PTRansition <NRf> | Program Sequence Transition Filter (PTR)     |

#### **Parameters**

|           |                |             |              |
|-----------|----------------|-------------|--------------|
| <NRf> = 0 | Clear Register | <NRf> = 128 | Set bit B7   |
| 1         | Set bit B0     | 256         | Set bit B8   |
| 2         | Set bit B1     | 512         | Set bit B9   |
| 4         | Set bit B2     | 1024        | Set bit B10  |
| 8         | Set bit B3     | 2048        | Set bit B11  |
| 16        | Set bit B4     | 16384       | Set bit B14  |
| 32        | Set bit B5     | 65535       | Set all bits |
| 64        | Set bit B6     |             |              |

#### **Query**

:PTRansition? Query PTR register

#### **Description**

These commands are used to program the positive transition (PTR) registers. A positive transition is defined as a 0 to 1 state change in the condition register. Thus, when an event is programmed for a positive transition, the appropriate bit in the corresponding event register sets when the corresponding bit in the condition register changes from 0 to 1. For example, if bit B9 of the Positive Transition Register of the Measurement Transition Filter is set, then the buffer full event is programmed for a positive transition. The BFL bit (B9) in the Measurement Event Register sets when the trace buffer becomes full. For details on register structure, see paragraph 3.7.

The PTR registers are shown in Figures 3-33A through 3-38A. Included is the decimal weight of each bit. The sum of the decimal weights of the bits that you wish to set is the parameter (<NRf>) that is sent with the command. For example, to program RAV (B5) and BFL (B9) measurement events for positive transitions, send the following command:

```
:stat:meas:ptr 544
```

$$\begin{aligned} \text{where; BFL (bit B9)} &= 512 \\ \text{RAV (bit B5)} &= 32 \\ \text{<NRf>} &= 544 \end{aligned}$$

**Effects of positive transitions on the Measurement Event Register:**

| Measurement event   | Positive transition effect on Measurement Event Register       |
|---------------------|----------------------------------------------------------------|
| Reading overflow    | Sets B0 when reading exceeds range limits.                     |
| Low limit 1         | Sets B1 when reading is less than the low limit 1 setting.     |
| High limit 1        | Sets B2 when reading is greater than the low limit 1 setting.  |
| Low limit 2         | Sets B3 when reading is less than the low limit 2 setting.     |
| High limit 2        | Sets B4 when reading is greater than the high limit 2 setting. |
| Reading available   | Sets B5 after a reading is taken and processed.                |
| Buffer available    | Sets B7 when the trace buffer has at least two readings.       |
| Buffer half full    | Sets B8 when the trace buffer becomes half full.               |
| Buffer full         | Sets B9 when the trace buffer becomes full.                    |
| Buffer pretriggered | Sets B11 when the trace buffer pretrigger event occurs.        |

| Bit Position      | B15 - B12 | B11                        | B10 | B9                       | B8                       | B7                       | B6  | B5                      | B4                      | B3                     | B2                     | B1                     | B0                     |
|-------------------|-----------|----------------------------|-----|--------------------------|--------------------------|--------------------------|-----|-------------------------|-------------------------|------------------------|------------------------|------------------------|------------------------|
| Event             | ---       | BPT                        | --- | BFL                      | BHF                      | BAV                      | --- | RAV                     | HL2                     | LL2                    | HL1                    | LL1                    | ROF                    |
| Decimal Weighting | ---       | 2048<br>(2 <sup>11</sup> ) | --- | 512<br>(2 <sup>9</sup> ) | 256<br>(2 <sup>8</sup> ) | 128<br>(2 <sup>7</sup> ) | --- | 32<br>(2 <sup>5</sup> ) | 16<br>(2 <sup>4</sup> ) | 8<br>(2 <sup>3</sup> ) | 4<br>(2 <sup>2</sup> ) | 2<br>(2 <sup>1</sup> ) | 1<br>(2 <sup>0</sup> ) |
| Value             | ---       | 0/1                        | --- | 0/1                      | 0/1                      | 0/1                      | --- | 0/1                     | 0/1                     | 0/1                    | 0/1                    | 0/1                    | 0/1                    |

Value : 1 = Enable Positive Transition  
0 = Disable Positive Transition

A) Positive Transition (PTR) Register

| Bit Position      | B15 - B12 | B11                        | B10 | B9                       | B8                       | B7                       | B6  | B5                      | B4                      | B3                     | B2                     | B1                     | B0                     |
|-------------------|-----------|----------------------------|-----|--------------------------|--------------------------|--------------------------|-----|-------------------------|-------------------------|------------------------|------------------------|------------------------|------------------------|
| Event             | ---       | BPT                        | --- | BFL                      | BHF                      | BAV                      | --- | RAV                     | HL2                     | LL2                    | HL1                    | LL1                    | ROF                    |
| Decimal Weighting | ---       | 2048<br>(2 <sup>11</sup> ) | --- | 512<br>(2 <sup>9</sup> ) | 256<br>(2 <sup>8</sup> ) | 128<br>(2 <sup>7</sup> ) | --- | 32<br>(2 <sup>5</sup> ) | 16<br>(2 <sup>4</sup> ) | 8<br>(2 <sup>3</sup> ) | 4<br>(2 <sup>2</sup> ) | 2<br>(2 <sup>1</sup> ) | 1<br>(2 <sup>0</sup> ) |
| Value             | ---       | 0/1                        | --- | 0/1                      | 0/1                      | 0/1                      | --- | 0/1                     | 0/1                     | 0/1                    | 0/1                    | 0/1                    | 0/1                    |

Value : 1 = Enable Negative Transition  
0 = Disable Negative Transition

B) Negative Transition (NTR) Register

**Figure 3-33**  
*Measurement Transition Filter*

**Effects of positive transitions on the Questionable Event Register:**

| Questionable event  | Positive transition effect on Questionable Event Register                 |
|---------------------|---------------------------------------------------------------------------|
| Temperature summary | Sets B4 when an invalid reference junction measurement has occurred.      |
| Calibration summary | Sets B8 when an invalid calibration constant is detected on power-up.     |
| Command warning     | Sets B14 when a Signal Oriented Measurement Command parameter is ignored. |

| Bit Position      | B15 | B14                         | B13 - B9 | B8                       | B7 - B5 | B4                      | B3 - B0 |
|-------------------|-----|-----------------------------|----------|--------------------------|---------|-------------------------|---------|
| Event             | —   | Warn                        | —        | Cal                      | —       | Temp                    | —       |
| Decimal Weighting | —   | 16384<br>(2 <sup>14</sup> ) | —        | 256<br>(2 <sup>8</sup> ) | —       | 16<br>(2 <sup>4</sup> ) | —       |
| Value             | 0   | 0/1                         | —        | 0/1                      | —       | 0/1                     | —       |

Value : 1 = Enable Positive Transition  
0 = Disable Positive Transition

## A) Positive Transition (PTR) Register

| Bit Position      | B15 | B14                         | B13 - B9 | B8                       | B7 - B5 | B4                      | B3 - B0 |
|-------------------|-----|-----------------------------|----------|--------------------------|---------|-------------------------|---------|
| Event             | —   | Warn                        | —        | Cal                      | —       | Temp                    | —       |
| Decimal Weighting | —   | 16384<br>(2 <sup>14</sup> ) | —        | 256<br>(2 <sup>8</sup> ) | —       | 16<br>(2 <sup>4</sup> ) | —       |
| Value             | 0   | 0/1                         | —        | 0/1                      | —       | 0/1                     | —       |

Value : 1 = Enable Negative Transition  
0 = Disable Negative Transition

## B) Negative Transition (NTR) Register

**Figure 3-34**  
*Questionable Transition Filter*

**Effects of positive transitions on the Operation Event Register:**

| Operation event | Positive transition effect on<br>Operation Event Register |
|-----------------|-----------------------------------------------------------|
| Calibrating     | Sets B0 at the start of calibration.                      |
| Measuring       | Sets B4 at the start of a measurement.                    |
| Trigger layer   | Sets B5 when waiting in the Trigger Layer.                |
| Arm layer       | Sets B6 when waiting in an arm layer.                     |
| Idle            | Sets B10 when entering the idle state.                    |

| Bit Position      | B15 - B11 | B10                        | B9 | B8 | B7 | B6                      | B5                      | B4 | B3 | B2 | B1                     | B0                     |
|-------------------|-----------|----------------------------|----|----|----|-------------------------|-------------------------|----|----|----|------------------------|------------------------|
| Event             | —         | Idle                       | —  | —  | —  | Arm                     | Trig                    | —  | —  | —  | Set                    | Cal                    |
| Decimal Weighting | —         | 1024<br>(2 <sup>10</sup> ) | —  | —  | —  | 64<br>(2 <sup>6</sup> ) | 32<br>(2 <sup>5</sup> ) | —  | —  | —  | 2<br>(2 <sup>1</sup> ) | 1<br>(2 <sup>0</sup> ) |
| Value             | —         | 0/1                        | —  | —  | —  | 0/1                     | 0/1                     | —  | —  | —  | 0/1                    | 0/1                    |

Value : 1 = Enable Positive Transition  
0 = Disable Positive Transition

A) Positive Transition (PTR) Register

| Bit Position      | B15 - B11 | B10                        | B9 | B8 | B7 | B6                      | B5                      | B4 | B3 | B2 | B1                     | B0                     |
|-------------------|-----------|----------------------------|----|----|----|-------------------------|-------------------------|----|----|----|------------------------|------------------------|
| Event             | —         | Idle                       | —  | —  | —  | Arm                     | Trig                    | —  | —  | —  | Set                    | Cal                    |
| Decimal Weighting | —         | 1024<br>(2 <sup>10</sup> ) | —  | —  | —  | 64<br>(2 <sup>6</sup> ) | 32<br>(2 <sup>5</sup> ) | —  | —  | —  | 2<br>(2 <sup>1</sup> ) | 1<br>(2 <sup>0</sup> ) |
| Value             | —         | 0/1                        | —  | —  | —  | 0/1                     | 0/1                     | —  | —  | —  | 0/1                    | 0/1                    |

Value : 1 = Enable Negative Transition  
0 = Disable Negative Transition

B) Negative Transition (NTR) Register

**Figure 3-35**  
*Operation Transition Filter*

**Effects of positive transitions on the Trigger Event Register:**

| Trigger event | Positive transition effect on Trigger Event Register |
|---------------|------------------------------------------------------|
| Sequence 1    | Sets B1 when waiting in Trigger Layer.               |

| Bit Position      | B15 - B2 | B1                     | B0 |
|-------------------|----------|------------------------|----|
| Event             | —        | Seq1                   | —  |
| Decimal Weighting | —        | 2<br>(2 <sup>1</sup> ) | —  |
| Value             | —        | 0/1                    | —  |

Value : 1 = Enable Positive Transition  
 0 = Disable Positive Transition

A) Positive Transition (PTR) Register

| Bit Position      | B15 - B2 | B1                     | B0 |
|-------------------|----------|------------------------|----|
| Event             | —        | Seq1                   | —  |
| Decimal Weighting | —        | 2<br>(2 <sup>1</sup> ) | —  |
| Value             | —        | 0/1                    | —  |

Value : 1 = Enable Negative Transition  
 0 = Disable Negative Transition

B) Negative Transition (NTR) Register

**Figure 3-36**  
 Trigger Transition Filter



**Effects of positive transitions on the Arm Event Register:**

| Arm event  | Positive transition effect on Arm Event Register |
|------------|--------------------------------------------------|
| Sequence 1 | Sets B1 when in an arm layer.                    |

|                   |          |                        |    |
|-------------------|----------|------------------------|----|
| Bit Position      | B15 - B2 | B1                     | B0 |
| Event             | —        | Seq1                   | —  |
| Decimal Weighting | —        | 2<br>(2 <sup>1</sup> ) | —  |
| Value             | —        | 0/1                    | —  |

Value : 1 = Enable Positive Transition  
0 = Disable Positive Transition

A) Positive Transition (PTR) Register

|                   |          |                        |    |
|-------------------|----------|------------------------|----|
| Bit Position      | B15 - B2 | B1                     | B0 |
| Event             | —        | Seq1                   | —  |
| Decimal Weighting | —        | 2<br>(2 <sup>1</sup> ) | —  |
| Value             | —        | 0/1                    | —  |

Value : 1 = Enable Negative Transition  
0 = Disable Negative Transition

B) Negative Transition (NTR) Register

**Figure 3-37**  
*Arm Transition Filter*

**Effects of positive transitions on the Sequence Event Register:**

| Sequence event | Positive transition effect on Sequence Event Register |
|----------------|-------------------------------------------------------|
| Layer 1        | Sets B1 when in Arm Layer 1.                          |
| Layer 2        | Sets B2 when in Arm Layer 2.                          |

| Bit Position      | B15 - B3 | B2                     | B1                     | B0 |
|-------------------|----------|------------------------|------------------------|----|
| Event             | —        | Lay2                   | Lay1                   | —  |
| Decimal Weighting | —        | 4<br>(2 <sup>2</sup> ) | 2<br>(2 <sup>1</sup> ) | —  |
| Value             | —        | 0/1                    | 0/1                    | —  |

Value : 1 = Enable Positive Transition  
0 = Disable Positive Transition

A) Positive Transition (PTR) Register

| Bit Position      | B15 - B3 | B2                     | B1                     | B0 |
|-------------------|----------|------------------------|------------------------|----|
| Event             | —        | Lay2                   | Lay1                   | —  |
| Decimal Weighting | —        | 4<br>(2 <sup>2</sup> ) | 2<br>(2 <sup>1</sup> ) | —  |
| Value             | —        | 0/1                    | 0/1                    | —  |

Value : 1 = Enable Negative Transition  
0 = Disable Negative Transition

B) Negative Transition (NTR) Register

**Figure 3-38**  
*Sequence Transition Filter*

**Program fragment**

```
PRINT #1, "output 16; :stat:oper:ptr 1026; ptr?" ' Set B1 and B10 of Operation
 PTR
PRINT #1, "enter 16" ' Get response message from
 2002
```

## 3.20.4

**:NTRansition <NRf>**

|                                                  |                                               |
|--------------------------------------------------|-----------------------------------------------|
| :STATus:MEASurement:NTRansition <NRf>            | Program Measurement Transition Filter (NTR).  |
| :STATus:QUEStionable:NTRansition <NRf>           | Program Questionable Transition Filter (NTR). |
| :STATus:OPERation:NTRansition <NRf>              | Program Operation Transition Filter (NTR).    |
| :STATus:OPERation:TRIGger:NTRansition <NRf>      | Program Trigger Transition Filter (NTR).      |
| :STATus:OPERation:ARM:NTRansition <NRf>          | Program Arm Transition Filter (NTR).          |
| :STATus:OPERation:ARM:SEQuence:NTRansition <NRf> | Program Sequence Transition Filter (NTR).     |

**Parameters**

|           |                            |             |                             |
|-----------|----------------------------|-------------|-----------------------------|
| <NRf> = 0 | Clear NTR register         | <NRf> = 128 | Set bit B7 of NTR register  |
| 1         | Set bit B0 of NTR register | 256         | Set bit B8 of NTR register  |
| 2         | Set bit B1 of NTR register | 512         | Set bit B9 of NTR register  |
| 4         | Set bit B2 of NTR register | 1024        | Set bit B10 of NTR register |
| 8         | Set bit B3 of NTR register | 2048        | Set bit B11 of NTR register |
| 16        | Set bit B4 of NTR register | 16384       | Set bit B14 of NTR register |
| 32        | Set bit B5 of NTR register | 65535       | Set all bits                |
| 64        | Set bit B6 of NTR register |             |                             |

**Query**

:NTRansition? Query NTR register

**Description**

These commands are used to program the negative transition (NTR) registers. A negative transition is defined as a 1 to 0 state change in the condition register. Thus, when an event is programmed for a negative transition, the appropriate bit in the corresponding event register sets when the corresponding bit in the condition register changes from 1 to 0. For example, if bit B9 of the Negative Transition Register of the Measurement Transition Filter is set, then the buffer full event is programmed for a negative transition. The BFL bit (B9) in the Measurement Event Register sets when the trace buffer is no longer full. For details on register structure, see paragraph 3.7.

The NTR registers are shown in Figures 3-33B through 3-38B. Included is the decimal weight of each bit. The sum of the decimal weights of the bits that you wish to set is the parameter (<NRf>) that is sent with the command. For example, to program RAV (B5) and BFL (B9) measurement events for negative transitions, send the following command:

```
:stat:meas:ntr 544
```

|                               |   |     |
|-------------------------------|---|-----|
| where; BFL (bit B9) = Decimal | = | 512 |
| RAV (bit B5) = Decimal        | = | 32  |
| <NRf> =                       | = | 544 |

**Effects of negative transitions on the Measurement Event Register:**

| Measurement event   | Negative transition effect on Measurement Event Register                     |
|---------------------|------------------------------------------------------------------------------|
| Reading overflow    | Sets B0 when a reading has gone from overflow to normal.                     |
| Low limit 1         | Sets B1 when the reading is no longer less than the low limit 1 setting.     |
| High limit 1        | Sets B2 when the reading is no longer greater than the low limit 1 setting.  |
| Low limit 2         | Sets B3 when the reading is no longer less than the low limit 2 setting.     |
| High limit 2        | Sets B4 when the reading is no longer greater than the high limit 2 setting. |
| Reading available   | Sets B5 when the next reading is being taken.                                |
| Buffer available    | Sets B7 when the trace buffer has become empty.                              |
| Buffer half full    | Sets B8 when the trace buffer is no longer half full.                        |
| Buffer full         | Sets B9 when the trace buffer is no longer full.                             |
| Buffer pretriggered | Sets when the trace buffer pretrigger operations are completed.              |

**Effects of negative transitions on the Questionable Event Register:**

| Questionable event  | Negative transition effect on Questionable Event Register                                                                                                         |
|---------------------|-------------------------------------------------------------------------------------------------------------------------------------------------------------------|
| Temperature summary | Sets B4 when a valid reference junction measurement follows an invalid reference junction measurement.                                                            |
| Calibration summary | Sets B8 when an invalid calibration constant clears after a successful calibration.                                                                               |
| Command warning     | Sets B14 when a Signal Oriented Measurement Command parameter executes correctly after a previous Signal Oriented Measurement Command parameter has been ignored. |

**Effects of negative transitions on the Operation Event Register:**

| Operation event | Negative transition effect on Operation Event Register |
|-----------------|--------------------------------------------------------|
| Calibrating     | Sets B0 at the end of calibration.                     |
| Measuring       | Sets B1 at the end of a measurement.                   |
| Trigger layer   | Sets B5 when leaving the Trigger Layer.                |
| Arm layer       | Sets B6 when leaving an arm layer.                     |
| Idle            | Sets B10 when leaving the idle state.                  |

**Effects of negative transitions on the Trigger Event Register:**

| Trigger event | Negative transition effect on Trigger Event Register |
|---------------|------------------------------------------------------|
| Sequence 1    | Sets B1 when leaving the Trigger Layer.              |

**Effects of negative transitions on the Arm Event Register:**

| Arm event  | Negative transition effect on Arm Event Register |
|------------|--------------------------------------------------|
| Sequence 1 | Sets B1 when leaving an arm layer.               |

**Effects of negative transitions on the Sequence Event Register:**

| Sequence event | Negative transition effect on Sequence Event Register |
|----------------|-------------------------------------------------------|
| Layer 1        | Sets B1 when leaving arm layer 1.                     |
| Layer 2        | Sets B2 when leaving arm layer 2.                     |

**Program fragment**

```
PRINT #1, "output 16; :stat:oper:ntr 1026; ntr?" ' Set B1 and B10 of Operation
 ' NTR
PRINT #1, "enter 16" ' Get response message from
 ' 2002
```

**3.20.5 :CONDition?**

|                                           |                                      |
|-------------------------------------------|--------------------------------------|
| :STATus:MEASurement:CONDition?            | Read Measurement Condition Register  |
| :STATus:QUEStionable:CONDition?           | Read Questionable Condition Register |
| :STATus:OPERation:CONDition?              | Read Operation Condition Register    |
| :STATus:OPERation:TRIGger:CONDition?      | Read Trigger Condition Register      |
| :STATus:OPERation:ARM:CONDition?          | Read Arm Condition Register          |
| :STATus:OPERation:ARM:SEQuence:CONDition? | Read Sequence Condition Register     |

**Description**

These query commands are used to read the contents of the condition registers. Each set of event registers (except the Standard Event register set) has a condition register. A condition register is similar to its corresponding event register, except that it is a real-time register that constantly updates to reflect the current operating status of the instrument.

See [:EVENT] for register bit descriptions. Note from the status structure (paragraph 3.7) that the condition registers precede the transition filters. Thus, only the PTR descriptions apply to the condition registers.

After sending one of these commands and addressing the Model 2002 to talk, a decimal value is sent to the computer. The binary equivalent of this decimal value indicates which bits in the register are set.

For example, if sending :stat:meas:cond? returns a decimal value of 512 (binary 0000001000000000), bit B9 of the Measurement Condition Register is set indicating that the trace buffer is full.

**Program fragment**

```
PRINT #1, "output 16; :stat:oper:cond?" ' Query Op Condition Register
PRINT #1, "enter 16" ' Get response message from 2002
```

**3.20.6 :PRESET**

:STATUS:PRESET Return registers to default conditions

**Description**

When this command is sent, the SCPI event registers are affected as follows:

1. All bits of the positive transition filter registers are set to one (1).
2. All bits of the negative transition filter registers are cleared to zero (0).
3. All bits of the following registers are cleared to zero (0):
  - A. Operation Event Enable Register.
  - B. Questionable Event Enable Register.
  - C. Measurement Event Enable Register.
4. All bits of the following registers are set to one (1):
  - A. Trigger Event Enable Register.
  - B. Arm Event Enable Register.
  - C. Sequence Event Enable Register.

Note: Registers not included in the above list are not affected by this command.

**Program fragment**

```
PRINT #1, "output 16; :stat:pres" ' Return registers to defaults
```

**3.20.7 :QUE commands****[:NEXT]?**

:STATus:QUEue[:NEXT]?    Read Error Queue

**Description**

As error and status messages occur, they are placed into the Error Queue. This query command is used to read those messages.

The Error Queue is a first-in, first-out (FIFO) register. Every time you read the queue, the “oldest” message is read and that message is then removed from the queue. The queue will hold up to 10 messages. If the queue becomes full, the message “350, ‘Queue Overflow’” will occupy the last memory location in the register. On power-up, the Error Queue is empty. When the Error Queue is empty, the message “0, ‘No error’” is placed in the Error Queue.

The messages in the queue are preceded by a number. Negative (-) numbers are used for SCPI defined messages, and positive (+) numbers are used for Keithley defined messages. The messages are listed in Table 2-4.

After this command is sent and the Model 2002 is addressed to talk, the “oldest” message in the queue is sent to the computer.

Note: The :STATus:QUEue[:NEXT]? query command performs the same function as the :SYSTem:ERRor? query command (see System subsystem).

**Program fragment**

```
PRINT #1, "output 16; :stat:que?" ' Query "oldest" message in queue
PRINT #1, "enter 16" ' Get response message from 2002
```

**ENABLE <list>**

:STATus:QUEue:ENABle &lt;list&gt;    Enable messages for Error Queue

**Parameters**

&lt;list&gt; = (numlist)

where; numlist is a specified list of messages that you wish to enable for the Error Queue.

**Query**

:ENABle?    Query list of enabled messages

**Description**

On power-up, all error messages are enabled and will go into the Error Queue as they occur. Status messages are not enabled and will not go into the queue. This command is used to specify which messages you want enabled. Messages not specified will be disabled and prevented from entering the queue.

When this command is sent, all messages will first be disabled, then the messages specified in the list will be enabled. Thus, the returned list (:ENABle?) will contain all the enabled messages.

Messages are specified by numbers (see Table 2-4). The following examples show various forms for expressing a message numlist:

|                  |                                                    |
|------------------|----------------------------------------------------|
| Numlist = -110   | Single message.                                    |
| -110, -140, -222 | Messages separated by commas.                      |
| -110:-222        | Range of messages (-100 through -222).             |
| -110:-222, -230  | Range entry and single entry separated by a comma. |

Note: To disable all messages from entering the Error Queue, send the following command:

```
:stat:que:enab ()
```

### Program fragment

```
PRINT #1, "output 16; :stat:que:enab (0:999); enab?" ' Enable all messages
 and query
PRINT #1, "enter 16" ' Get response message
 from 2002
```

### **DISable** <list>

```
:STATus:QUEue:DISable <list> Disable messages for Error Queue
```

### Parameters

<list> = (numlist)

where; numlist is a specified list of messages that you wish to disable for the Error Queue.

### Query

```
:DISable? Query list of disabled messages
```

### Description

On power-up, all error messages are enabled and will go into the Error Queue as they occur. Status messages are not enabled and will not go into the queue. This command is used to specify which messages you want disabled. Disabled messages are prevented from going into the Error Queue.

Messages are specified by numbers (see Table 2-4). See :QUEue:ENABle for examples to express a numlist.

### Program fragment

```
PRINT #1, "output 16; :stat:que:dis (-140:-150); dis?" ' Disable messages
 and query
PRINT #1, "enter 16" ' Get response mes-
 sage from 2002
```

### **:CLEar**

```
:STATus:QUEue:CLEar Clear Error Queue
```

### Description

This action command is used to clear the Error Queue of messages.

### Program fragment

```
PRINT #1, "output 16; :stat:que:cle" ' Clear Error Queue
```

## 3.21 :SYSTem subsystem

The SYSTem subsystem contains miscellaneous commands that are summarized in Table 3-16.

### 3.21.1 :PRESet

:SYSTem:PRESet    Return to :SYSTem:PRESet defaults

#### Description

This command returns the instrument to states optimized for front panel operation. :SYSTem:PRESet defaults are listed in the SCPI tables (Tables 3-4 through 3-16).

#### Program fragment

```
PRINT #1, "output 16; :syst:pres" ' Return 2002 to default conditions
```

### 3.21.2 :POSetup <name>

:SYSTem:POSetup <name>    Program power-on defaults

#### Parameters

<name> =    RST            Select \*RST defaults on power up  
             PRESet        Select :SYSTem:PRESet defaults on power up  
             SAVX           Select saved defaults on power up

where; X = 0 to 9

#### Query

:POSetup?    Query power-on setup

#### Description

This command is used to select the power-on defaults. With RST selected, the instrument powers up to the \*RST default conditions. With PRES selected, the instrument powers up to the :SYSTem:PRESet default conditions. Default conditions are listed in the SCPI tables (Tables 3-4 through 3-16).

With one of the SAV parameters selected, the instrument powers-on to the setup that is saved in the specified memory location using the \*SAV command. Valid SAV parameters depend on which memory option is installed in the Model 2002 and are summarized as follows:

| Memory option | Valid SAV parameters |
|---------------|----------------------|
| STD           | SAV0                 |
| MEM1          | SAV0 through SAV4    |
| MEM2          | SAV0 through SAV9    |

#### Program fragment

```
PRINT #1, "output 16; :syst:pos pres; pos?" ' Select power-on defaults
PRINT #1, "enter 16" ' Get response message from 2002
```

### 3.21.3 :FRSWitch?

:SYSTem:FRSWitch?    Read INPUTS switch

#### Description

This query command is used to read the position of the FRONT/REAR INPUTS switch. Switch position code is defined as follows:

1 = Front panel inputs selected  
 0 = Rear panel inputs selected

#### Program fragment

```
PRINT #1, "output 16; :syst:frsw?" ' Query INPUTS switch position
PRINT #1, "enter 16" ' Get response message from 2002
```



**3.21.4 :VERsion?**

:SYSTem:VERsion? Read SCPI version

**Description**

This query command is used to read the version of the SCPI standard being used by the Model 2002. Example code:

1991.0

The above response message indicates the version of the SCPI standard.

**Program fragment**

```
PRINT #1, "output 16; :syst:vers?" ' Query version of SCPI standard
PRINT #1, "enter 16" ' Get response message from 2002
```

**3.21.5 :ERRor?**

:SYSTem:ERRor? Read Error Queue

**Description**

As error and status messages occur, they are placed into the Error Queue. This query command is used to read those messages. The Error Queue is a first-in, first-out (FIFO) register that can hold up to 10 messages. Every time you read the queue, the “oldest” message is read and that message is then removed from the queue.

If the queue becomes full, the message “350, ‘Queue Overflow’” occupies the last memory location in the register. On power-up, the queue is empty. When the Error Queue is empty, the message “0, ‘No error’” is placed in the Error Queue.

The messages in the queue are preceded by a number. Negative (-) numbers are used for SCPI defined messages, and positive (+) numbers are used for Keithley defined messages. Table 2-4 lists the messages.

NOTE: The :SYSTem:ERRor? query command performs the same function as the :STATus:QUEue? query command (see STATus subsystem).

**Program fragment**

```
PRINT #1, "output 16; :syst:err?" ' Query Error Queue
PRINT #1, "enter 16" ' Get response message from 2002
```

**3.21.6 :AZERo commands****:TYPE <name>**

:SYSTem:AZERo:TYPE &lt;name&gt; Specify autozero type

**Parameters**

```
<name> = NORMAL Autozero every 200msec
 SYNChronous Autozero for every reading
```

**Query**

:TYPE? Query autozero type

**Description**

The :AZERo commands are used to control the autozero phase of each measurement. Auto-zero is explained in paragraph 2.12.7. The :AZERo:STATe command is used to enable or disable autozero.

**Program fragment**

```
PRINT #1, "output 16; :syst:azer:type sync; type?" ' Select SYNC autozero
PRINT #1, "enter 16" ' Get response message from 2002
```

**:STATE <b>**

:SYSTem:AZERo:STATe &lt;b&gt; Control autozero

**Parameters**

<b> = 1 or ON Enable autozero  
 0 or OFF Disable autozero

**Query**

:STATe? Query state of autozero

**Description**

This command is used to disable or enable autozero.

**Important Note:** Before you can enable or disable auto-zero, the Model 2002 must first be in the idle state. The Model 2002 can be placed in the idle state by first disabling continuous initiation (:INITiate:CONTInuous OFF), and then sending the :ABORt command. After sending the :STATe command, readings can be re-started by sending :INITiate:CONTInuous ON or :INITiate.

**Program fragment**

```
PRINT #1, "output 16; :init:cont off; :abor" ' Place 2002 in idle
PRINT #1, "output 16; :syst:azer:stat off; stat?" ' Disable autozero
PRINT #1, "enter 16" ' Get response from 2002
LINE INPUT #2, a$ ' Read response
PRINT a$ ' Display response
PRINT #1, "output 16; :init:cont on" ' Take 2002 out of idle
```

NOTE: When finished, be sure to re-enable autozero.

**3.21.7****:AMETHod <name>**

:SYSTem:AMETHod &lt;name&gt; Specify acquisition method

**Parameters**

<name> = NORMAL Normal acquisition method for buffer  
 BURSt Burst acquisition method for buffer  
 ASTReam ASCII stream mode  
 SSTReam Single integer stream mode

**Query**

:AMETHod? Query acquisition method

**Description****BURST and NORMAl**

These parameters are used to specify the acquisition method for storing readings in the buffer. With the NORMAL method, readings are stored at a rate that is determined by how the instrument is configured (i.e. integration period, resolution and filter).

When BURSt acquisition is selected, the Model 2002 is automatically configured for optimum speed (The instrument's previous configuration is restored when normal acquisition is again selected). The burst mode configures the buffer for compact grouping (see :TRACe:EGRoup). Thus, the time-stamp is not available for burst acquisition. See paragraph 2.8 for complete information on burst mode.

Before selecting the burst acquisition mode, configure the Model 2002 for the desired measurements (such as a valid function, a manual measurement range, and a math calculation (:CALCulate1) if desired). Also, configure the buffer for the number of readings to be stored (see Trace subsystem).

After burst acquisition is selected, the instrument goes into the idle state (ARM indicator off). After taking the instrument out of idle (:INITiate or :INITiate:CONTInuous ON), the programmed scan event (see :ARM:LAYer2 SOURce) will start the storage process.

When storage starts, the ARM indicator turns on to denote that raw input readings are being stored in the buffer. After the storage process is finished, the \* indicator turns on to denote that post processing (i.e. math calculations) is being performed on the readings. When post processing is finished, the \* indicator turns off and the instrument returns to the idle state. The Trace subsystem is used to read the buffer.

Sending a bus command to the Model 2002 while raw readings are being acquired aborts the acquisition and post processes the readings already stored in the buffer.

### **ASTReam and SSTReam**

These two “stream” parameters are used to send “fresh” A/D readings over the IEEE-488 bus at maximum speed. The ASTReam parameter is used to send readings in the ASCII format, and the SSTReam parameter is used to send readings in the Single Integer (counts) format. The stream modes can be used for the following functions: DCV, ACV (average and RMS), DCI, ACI (average and RMS) and  $\Omega 2$ . TEMP, FREQ,  $\Omega 4$ , in-circuit current, and peak measurements cannot be used with stream mode.

With ASTReam, up to 1000 readings per second can be sent over the bus, and with SSTReam, up to 2000 readings per second can be sent. Once the Model 2002 is placed in a stream mode, one A/D reading is sent over the bus every time the instrument is addressed to talk.

#### **ASCII stream mode:**

With ASTReam, only the reading is sent. All other data elements (units, reading number, time stamp, etc.) are not included.

A line feed (LF) with EOI is used as a terminator for each reading. An overflowed reading is returned as a +/-30,000 count reading. For example, a 10k $\Omega$  resistor being measured on the 2k $\Omega$  range will return the following overranged reading:

+3.0000E+03      (Overranged ASTReam reading)

#### **Single integer stream mode:**

The SSTReam mode sends single precision integer readings. Each reading is 2-bytes in size and is not terminated by a line feed (LF). EOI is asserted with the second byte of each reading.

With SSTReam, only the number of A/D counts are sent. For example, a 1.5V reading on the 2V range will be sent as follows:

15000

The same reading (1.5V) on the 20V range is sent as follows:

1500

An overrange reading is expressed as +/-30,000 counts. For example, if a 50k $\Omega$  resistor is measured on the 20k $\Omega$  range, the overranged reading will be expressed as follows:

30000      (Overranged SSTReam reading)

#### **Operating considerations:**

Before going into a stream mode, make sure the instrument is on the desired function and range. Once in a stream mode, all front panel controls are disabled, and all SCPI and Common commands are ignored.

Before going into the SStream mode, make sure the data format byte order is correct for your computer. IBM and IBM compatibles require the swapped byte order and HP requires normal byte order (see :FORMat:BORDER).

**Important Note:** Before going into a stream mode, the instrument must be in continuous initiation. If continuous initiation is disabled (or you are not sure), send the following command to enable it:

```
:INITiate:CONTInuous ON
```

When the :AMETHod command is sent with one of the stream parameters, the instrument will go into the stream mode and lock out all front panel controls, and ignore all SCPI and Common commands. When a stream mode is entered, you must wait before addressing the Model 2002 to talk. The minimum delay period is dependent on function and range (see Table 3-17). In a stream mode, the instrument configures itself as follows:

```
Auto zero disabled (:SYSTem:AZERo:STATe OFF)
CALC 1 disabled (:CALCulate[1]:STATe OFF)
Line synchronization disabled (:SYSTem:LSYNc:STATe OFF)
```

For each valid function:

```
<function> = :VOLTage:AC
 :VOLTage:DC
 :CURRent:AC
 :CURRent:DC
 :RESistance
```

```
Auto range disabled (<function>:RANGe:AUTO OFF)
NPLC = 0.01 (<function>:NPLCycles 0.01)
Auto NPLC disabled (<function>:NPLCycles:AUTO OFF)
Resolution = 4 digits (<function>:DIGits 5)
Auto resolution disabled (<function>:DIGits:AUTO OFF)
Filter disabled (<function>:AVERage:STATe OFF)
Auto filter disabled (<function>:AVERage:AUTO OFF)
Reference disabled (<function>:REFerence:STATe OFF)
```

The stream mode is cancelled when a device clear (DCL or SDC) is sent to the Model 2002. Keep in mind that the instrument remains at the settings that it assumed for the stream mode. After cancelling the stream mode, again wait before sending any more commands. (See Table 3-17.)

The delay times in Table 3-17 only account for processing the stream command and the device clear command. Commands that precede the stream command must be allowed to finish executing before the stream command is sent. The \*OPC? command is recommended for this purpose. When \*OPC? is sent, subsequent commands will not execute until the operations of all previous commands are completed. The use of \*OPC? is demonstrated in Program Fragment #2.

**Triggering** — In stream, the trigger model functions normally except that the Manual and Hold control sources cannot be used. The Group Execute Trigger (GET) is functional when the Bus control source is selected. For optimum speed, set up the measure layer for Immediate control source, infinite count and zero delay.

**Reading Rates** — The maximum possible reading rate for the SStream mode is 2000 per second and is only achievable for controllers that can pull each reading out of the Model 2002 in less than 100µsec. The maximum possible reading rate for the AStream mode is 1000 per sec-

ond. Maximum reading rates require that the measure layer of the trigger model be configured for the Immediate control source, infinite count and zero delay. When externally triggered (EXT, TLINK, TIMER or GET), the maximum reading rate for either stream mode is 680 per second.

**Table 3-17**  
*Minimum delay times for stream mode*

| Function              | Range         | Delay (msec) |
|-----------------------|---------------|--------------|
| DCV                   | 200mV         | 150          |
|                       | 2V            | 160          |
|                       | 20V           | 150          |
|                       | 200V          | 220          |
|                       | 1000V         | 210          |
| ACV (RMS and average) | 200mV         | 270          |
|                       | 2V            | 260          |
|                       | 20V           | 210          |
|                       | 200V          | 200          |
|                       | 750V          | 210          |
| DCI                   | 200 $\mu$ A   | 130          |
|                       | 2mA           | 140          |
|                       | 20mA          | 170          |
|                       | 200mA         | 140          |
|                       | 2A            | 190          |
| ACI (RMS and average) | 200 $\mu$ A   | 230          |
|                       | 2mA           | 180          |
|                       | 20mA          | 230          |
|                       | 200mA         | 220          |
|                       | 2A            | 160          |
| $\Omega$              | 20 $\Omega$   | 190          |
|                       | 200 $\Omega$  | 180          |
|                       | 2k $\Omega$   | 140          |
|                       | 20k $\Omega$  | 170          |
|                       | 200k $\Omega$ | 270          |
|                       | 2M $\Omega$   | 880          |
|                       | 20M $\Omega$  | 1840         |
|                       | 200M $\Omega$ | 1920         |
| 1G $\Omega$           | 1920          |              |

#### Program fragment #1 Burst acquisition

```
PRINT #1, "output 16; :syst:amet burs" ' Select burst mode
PRINT #1, "output 16; :init" ' Start acquisition process
```

#### Program fragment #2 ASTReam mode

```
PRINT #1, "output 16; *opc?" ' Send *opc?
PRINT #1, "enter 16" ' Wait for operation complete
PRINT #1, "output 16; :syst:amet astr" ' Go into ASTReam mode
SLEEP 1 ' Wait for 1 second
FOR I = 1 TO 200 ' Set counter to loop 200 times
PRINT #1, "enter 16" ' Get reading from 2002
```

```

NEXT I ' Repeat loop until 200 rdgs acquired
PRINT #1, "clear 16" ' Cancel stream mode
SLEEP 1 ' Wait 1 second

```

### 3.21.8 :LSYNc:STATe <b>

:SYSTem:LSYNc:STATe <b> Control line synchronization

#### Parameters

<b> = 0 or OFF Disable line synchronization  
1 or ON Enable line synchronization

#### Query

:STATe? Query state of line synchronization

#### Description

This command is used to enable or disable line synchronization. When enabled, the integration period will not start until the beginning of the next power line cycle. For example, if a reading is triggered at the positive peak of a power line cycle, the integration period will not start until that power line cycle is completed. The integration period starts when the positive-going sine wave crosses zero volts.

With line synchronization disabled, the integration period starts when the reading is triggered. See paragraph 2.12.7 for details.

**IMPORTANT NOTE:** The Model 2002 must first be in idle before you can enable line synchronization.

#### Program fragment

```

PRINT #1, "output 16; :init:cont off; :abor" ' Place 2002 in idle
PRINT #1, "output 16; :syst:lsyn:stat on; stat?" ' Enable line sync
PRINT #1, "enter 16" ' Get response from 2002
PRINT #1, "output 16; :init"" ' Take 2002 out of idle

```

### 3.21.9 :KEY <NRf>

:SYSTem:KEY <NRf> Simulate key-press

#### Parameters

|           |             |            |            |
|-----------|-------------|------------|------------|
| <NRf> = 1 | Up Arrow    | <NRf> = 16 | NEXT       |
| 2         | TEMP        | 17         | Down Arrow |
| 3         | Left Arrow  | 18         | ENTER      |
| 4         | MENU        | 19         | Ω4         |
| 5         | ACI         | 20         | FILTER     |
| 6         | STORE       | 21         | SCAN       |
| 7         | LOCAL       | 22         | ACV        |
| 8         | PREV        | 23         | REL        |
| 9         | AUTO        | 26         | FREQ       |
| 10        | Right Arrow | 27         | MAT        |
| 11        | EXIT        | 28         | CONFIG     |
| 12        | Ω2          | 29         | DCI        |
| 13        | RECALL      | 30         | TRIG       |
| 14        | CHAN        | 31         | INFO       |
| 15        | DCV         |            |            |

#### Query

:KEY? Query last "pressed" key.

#### Description

This command is used to simulate front panel key presses. For example, to select DCV you can send the following command to simulate pressing the DCV key:

:syst:key 15

The parameter listing provides the key-press code in numeric order. Figure 3-39 also provides the key-press code.

The :KEY command allows you to select the NEXT displays over the bus. Sending :SYSTEM:KEY 16 over the bus is the same as a single press of the NEXT key. Sending :SYSTEM:KEY 8 is the same as a single press of the PREV key. The NEXT display that is selected depends on which function is currently selected and how many times the NEXT key is “pressed” using the :KEY command. The instrument can always be returned to the normal display by “pressing” the PREV key a similar number of times, or by sending the :DISPLAY:CNDisplay command.

For example, on the FREQ function, you can display the trigger level by “pressing” the NEXT key twice as follows:

```
:syst:key 16; key 16
```

To return to the normal display, “press” the PREV key twice as follows:

```
:syst:key 8; key 8
```

The queue for the :KEY? query command can only hold one key-press. When :KEY? is sent over the bus, and the Model 2002 is addressed to talk, the key-press code number for the last key pressed (either physically or with :KEY) is sent to the computer.

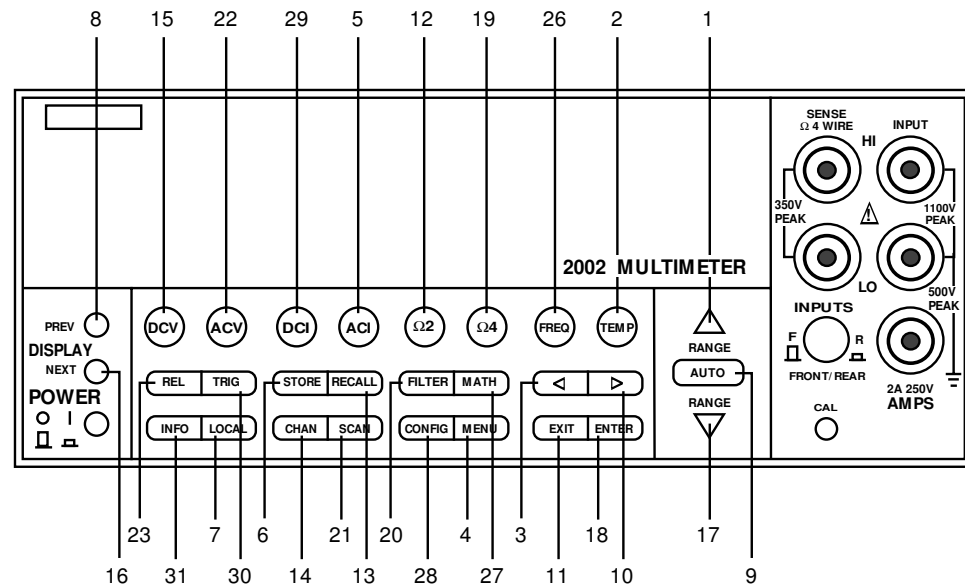

**Figure 3-39**  
Key-press codes

### Program fragment

```
PRINT #1, "output 16; :syst:key 29" ' Select DCI function
SLEEP 3 ' Wait 3 seconds
PRINT #1, "output 16; :syst:key 16; key 16" ' Select Zero Center Bar Graph
SLEEP 3 ' Wait 3 seconds
PRINT #1, "output 16; :syst:key 8; key 8" ' Return to normal display
```

**3.21.10****:CLEAR**

:SYSTEM:CLEAr Clear Error Queue

**Description**

This action command is used to clear the Error Queue of messages.

**Program fragment**

```
PRINT #1, "output 16; :syst:cle" ' Clear Error Queue
```

**3.21.11****:LFRrequency**

:SYSTEM:LFRrequency Query power line frequency

**Description**

This query command is used to read the frequency of the power line that powers the Model 2002.

**Program fragment**

```
PRINT #1, "output 16; :syst:lfr?" ' Query the power line
PRINT #1, "enter 16" ' Get response from 2002
```

**3.21.12****:DATE<yr>, <mo>, <day>**

:SYSTEM:DATE &lt;yr&gt;, &lt;mo&gt;, &lt;day&gt; Set date for clock

**Parameters**

```
<yr> = 1993 to 2092 Specify year
<mo> = 1 to 12 Specify month
<day> = 1 to 31 Specify day
```

**Query**

:DATE? Query the date

**Description**

This command is used to set the date for the real-time clock. Setting an invalid date (i.e. February 29, 1994) result in an error and the previous date is retained.

**Program fragment**

```
PRINT #1, "output 16; :syst:date <1993>, <12>, <1>; date?" ' Set date to
 December 1, 1993
 and query
PRINT #1, "enter 16" ' Get response
 message
 from
 2002
```

**3.21.13****:TIME<hr>, <min>, <sec>**

:SYSTEM:TIME &lt;hr&gt;, &lt;min&gt;, &lt;sec&gt; Set time for clock

**Parameters**

```
<hr> = 0 to 23 Specify hour (24 hr format)
<min> = 0 to 59 Specify minute
<sec> = 0.00 to 59.99 Specify second (rounded to 1/100 sec.)
```

**Query**

:TIME? Query the time

**Description**

This command is used to set the time for the real-time clock. Note that the time must be set using the 24-hour format (i.e. hour 13 is 1PM). Setting an invalid time results in an error and the previous time is retained.

:TIME? returns the time to nearest hundredth of a second.

**Program fragment**

```
PRINT #1, "output 16; :syst:time <14>, <36>, <0>; time?" ' Set time to 2:36
 pm and query
PRINT #1, "enter 16" ' Get response mes-
 sage
 from 2002
```



**3.21.14 :TSTamp commands**

The following commands are used to configure and control the timestamp. For more information on timestamp, see paragraphs 3.14 (:FORMat:ELEMents) and 3.22.7 (:TRACe:TSTamp:FORMat).

**:TYPE <name>**

:SYSTem:TSTamp:TYPE <name> Select timestamp type

**Parameters**

<name> = RELative Select relative-time timestamp<sup>1</sup>  
 RTClock Select real-time timestamp<sup>2</sup>

<sup>1</sup> RELative is a 55 day (max.) clock at a 1µs resolution.

<sup>2</sup> RTClock is a 100 year (max.) calendar at a 10ms resolution.

**Query**

:TYPE? Query timestamp type

**Description**

This command is used to select the timestamp type. RTClock selects the real-time clock timestamp. Readings are reference to the date and time. RELative selects the relative-time timestamp. Readings are referenced (in seconds) to a timer. The timer starts at zero seconds when the instrument is turned on or when the timestamp is reset (see next command).

**Program fragment**

```
PRINT #1, "output 16; :syst:tst:type rtc; type?" ' Select RTClock and query
PRINT #1, "enter 16" ' Get response message from 2002
```

**:RELative:RESet**

:SYSTem:TSTamp:RELative:RESet Reset relative timestamp to 0.

**Description**

This action command is used to reset the relative-time timestamp to zero seconds.

**Program fragment**

```
PRINT #1, "output 16; :syst:tst:rel:res" ' Reset relative timestamp
```

**3.21.15 :RNUMBER:RESet**

:SYSTem:RNUMBER:RESet Reset reading number to zero

When the reading number is included as a GPIB data element (see paragraph 3.14; :FORMat:ELEMents), each reading sent over the bus is assigned a number starting at #0. The reading number resets to zero when the instrument is turned on or when this action command is asserted.

**Program fragment**

```
PRINT #1, "output 16; :syst:rnum:res" ' Reset reading number
```

## 3.22 :TRACe subsystem

The commands in this subsystem are used to configure and control data storage into the buffer. The commands are summarized in Table 3-14. See paragraph 2.8 for more information about the buffer.

### :TRACe| :DATA

The bar (|) indicates that :TRACe or :DATA can be used as the root command for this subsystem. From this point on, the documentation in this manual uses :TRACe. If you prefer to use :DATA, simply replace all the :TRACe command words with :DATA.

#### 3.22.1

##### :CLEAr

:TRACe:CLEAr    Clear buffer

##### Description

This action command is used to clear the buffer of readings. If you do not clear the buffer, a subsequent store will overwrite the old readings. If the subsequent store is aborted before the buffer becomes full, you could end up with some “old” readings still in the buffer.

##### Program fragment

```
PRINT #1, "output 16; :trac:clear" ' Clear buffer
```

#### 3.22.2

##### :FREE?

:TRACe:FREE?    Read status of memory

##### Description

This command is used to read the status of storage memory. After sending this command and addressing the Model 2002 to talk, two values separated by commas are sent to the computer. The first value indicates how many bytes of memory are available, and the second value indicates how many bytes are reserved to store readings.

##### Program fragment

```
PRINT #1, "output 16; :trac:free?" ' Query status of memory
PRINT #1, "enter 16" ' Get response from 2002
```

#### 3.22.3

##### :EGRoup <name>

:TRACe:EGRoup <name>    Specify element group

##### Parameters

<name> =    FULL        Time stamp included with each stored reading  
            COMPact    Time stamp not included

##### Query

:EGRoup?    Query element group

##### Description

This command is used to select the element group that is sent with each reading. Common to both element groups are function, channel (if applicable) and buffer location. The FULL element group includes the time stamp. The first reading in the buffer has a time stamp of 0 seconds. The time stamp for all subsequent readings are then referenced to the first reading.

The COMPact element group excludes the time stamp. This allows more readings to be stored in the buffer (see :POINTs).

##### Program fragment

```
PRINT #1, "output 16; :trac:egr comp; egr?" ' Select compact element group
PRINT #1, "enter 16" ' Get response from 2002
```

**3.22.4 :POINTS <n>**

:TRACe:POINTS &lt;n&gt; Specify buffer size

**Parameters**

	No memory option	MEM 1	MEM 2	
<n> =	2 to 404	2 to 1381	2 to 5980	(Full)
	2 to 2027	2 to 6909	2 to 29908	(Compact)
MAXimum	404	1381	5980	(Full)
	2027	6909	29908	(Compact)
DEFault	100 (all cases)			
MINimum	2 (all cases)			

**Query**

:POINTS?

**Description**

This command is used to specify the size of the buffer. Notice that the valid parameter range depends on which memory option is installed, and which element group (full or compact) is being used (see :EGROUP).

**Program fragment**

```
PRINT #1, "output 16; :trac:poin 50; poin?" ' Set size of buffer
PRINT #1, "enter 16" ' Get response from 2002
```

**:AUTO <b>**

:TRACe:POINTS:AUTO &lt;b&gt; Control auto buffer sizing

**Parameters**

<b> = 0 or OFF    Disable auto buffer sizing  
           1 or ON    Enable auto buffer sizing

**Query**

:AUTO?

**Description**

This command is used to enable or disable auto buffer sizing. When enabled, the buffer size defaults to the measure count value in the Trigger Model (see :TRIGGER:COUNT in Trigger subsystem). With auto buffer enabled, changing the Trigger Model's measure count value changes the buffer size to that value.

Disabling auto buffer sizing does not affect the size of the buffer. It simply means that you must then use the :POINTS command to change the buffer size.

If you use the :POINTS command to change the buffer size while auto is enabled, the buffer size changes to that value and auto buffer sizing disables.

If you try to enable auto buffer sizing while the measure count is programmed for infinite, an error will occur and the command will be ignored. You cannot have an infinite buffer size.

**Program fragment**

```
PRINT #1, "output 16; :trig:coun 200" ' Set measure count
PRINT #1, "output 16; :trac:poin:auto on; auto?" ' Enable auto buffer sizing
PRINT #1, "enter 16" ' Get response from 2002
```

**3.22.5 :FEED <name>**

:TRACe:FEED &lt;name&gt; Specify readings source

**Parameters**

<name> = SENSE[1]    Put raw readings in buffer  
           CALCulate[1]    Put calculated readings in buffer  
           NONE    Put no readings in buffer

<b>Query</b>	:FEED? Query buffer feed																														
<b>Description</b>	<p>This command is used to select the source of readings to be placed in the buffer. With SENSE[1] selected, raw readings are placed in the buffer when storage is performed. With CALCulate[1] selected, calculated math readings (POLYnomial or PERCent or NONE) are placed in the buffer.</p> <p>With NONE selected, no readings are placed in the buffer when storage is performed over the bus.</p>																														
<b>Program fragment</b>	<pre>PRINT #1, "output 16; :trac:feed calc; feed?"      ' CALC1 buffer readings PRINT #1, "enter 16"                              ' Get response from 2002</pre>																														
	<p><b>:[PERCent] &lt;n&gt;</b>  :TRACe:FEED:PRETrigger:AMOut:[PERCent] &lt;n&gt; Specify percent of pre-trigger readings</p>																														
<b>Parameters</b>	<table border="0"> <tr> <td>&lt;n&gt; =</td> <td>0 to 100</td> <td>% of buffer for pre-trigger readings</td> </tr> <tr> <td></td> <td>DEFault</td> <td>50% of buffer for pre-trigger readings</td> </tr> <tr> <td></td> <td>MINimum</td> <td>0% of buffer for pre-trigger readings</td> </tr> <tr> <td></td> <td>MAXimum</td> <td>100% of buffer for pre-trigger readings</td> </tr> </table>	<n> =	0 to 100	% of buffer for pre-trigger readings		DEFault	50% of buffer for pre-trigger readings		MINimum	0% of buffer for pre-trigger readings		MAXimum	100% of buffer for pre-trigger readings																		
<n> =	0 to 100	% of buffer for pre-trigger readings																													
	DEFault	50% of buffer for pre-trigger readings																													
	MINimum	0% of buffer for pre-trigger readings																													
	MAXimum	100% of buffer for pre-trigger readings																													
<b>Query</b>	: [PERCent]?																														
<b>Description</b>	<p>This command is used to specify how much of the defined buffer (:POINTS) will be used to store pre-triggered readings. When a pre-trigger store is started (see :FEED:CONTRol), readings are continuously stored in the buffer. When the pre-trigger event occurs (see :PRETrigger:SOURce), post-trigger readings will then fill the part of the buffer that is not reserved for pre-trigger readings.</p> <p>For example, assume 25% of a 100 point buffer is reserved for pre-trigger readings. When the pre-trigger store is started, readings continuously fill the buffer. When the pre-trigger event occurs, subsequent readings will then be stored starting at buffer location 26 and continue until buffer location 100 is filled. Storage stops after buffer location 100 is filled. The result is 25 pre-trigger readings and 75 post-trigger readings. See paragraph 2.8.2 for more information about pre-trigger.</p>																														
<b>Program fragment</b>	<pre>PRINT #1, "output 16; :trac:feed:pret:amo 25; amo?"  ' 25% for pre-trigger                                                     rdgs PRINT #1, "enter 16"                                ' Get response from 2002</pre>																														
	<p><b>:READings &lt;n&gt;</b>  :TRACe:FEED:PRETrigger:AMOut:READings &lt;n&gt; Specify number of pre-trigger readings</p>																														
<b>Parameters</b>	<table border="0"> <thead> <tr> <th></th> <th>No memory option</th> <th>MEM 1</th> <th>MEM 2</th> <th></th> </tr> </thead> <tbody> <tr> <td>&lt;n&gt; =</td> <td>0 to 404</td> <td>0 to 1381</td> <td>0 to 5980</td> <td>(Full)</td> </tr> <tr> <td></td> <td>0 to 2027</td> <td>0 to 6909</td> <td>0 to 29908</td> <td>(Compact)</td> </tr> <tr> <td>MAXimum</td> <td colspan="4">Present buffer size (which is set by TRACe:POINTS)</td> </tr> <tr> <td>DEFault</td> <td colspan="4">Half present buffer size (which is set by TRACe:POINTS)</td> </tr> <tr> <td>MINimum</td> <td colspan="4">0 (all cases)</td> </tr> </tbody> </table>		No memory option	MEM 1	MEM 2		<n> =	0 to 404	0 to 1381	0 to 5980	(Full)		0 to 2027	0 to 6909	0 to 29908	(Compact)	MAXimum	Present buffer size (which is set by TRACe:POINTS)				DEFault	Half present buffer size (which is set by TRACe:POINTS)				MINimum	0 (all cases)			
	No memory option	MEM 1	MEM 2																												
<n> =	0 to 404	0 to 1381	0 to 5980	(Full)																											
	0 to 2027	0 to 6909	0 to 29908	(Compact)																											
MAXimum	Present buffer size (which is set by TRACe:POINTS)																														
DEFault	Half present buffer size (which is set by TRACe:POINTS)																														
MINimum	0 (all cases)																														

**Query** :READ?

**Description**

This command is used to specify how much of the defined buffer (:POINTs) will be used to store pre-triggered readings. This command is essentially the same as the :PERCent command except the amount is expressed as an exact value instead of a percent.

Sending a value that exceeds the defined size of the buffer (see :POINTs) generates an error. The command is ignored.

**Program fragment**

```
PRINT #1, "output 16; :trac:poin; 75" ' Set buffer size
PRINT #1, "output 16; :trac:feed:pret:amo:read 30; read?" ' 30 pre-trigger
 rds for buffer
PRINT #1, "enter 16" ' Get response from
 2002
```

**:SOURce <name>**

:TRACe:FEED:PRETrigger:SOURce <name> Specify pre-trigger event

**Parameters**

<name> =    EXTERNAL    Use External Trigger as pre-trigger event  
              TLINK        Use Trigger Link as pre-trigger event  
              BUS          Use bus trigger as pre-trigger event  
              MANUAL      Use TRIG key as pre-trigger event

**Query** :SOURce? Query buffer source.

**Description**

This command is used to specify the event for the pre-trigger storage mode. With the pre-trigger mode selected (:CONTRol, PRETrigger), readings are continuously stored in the buffer while waiting for the pre-trigger source event.

With EXTERNAL source selected, an external trigger via the rear panel EXTERNAL TRIGGER Input provides the pre-trigger event.

With TLINK selected, an input trigger via the Trigger Link provides the pre-trigger event. The Trigger Link line used for the input trigger is programmed from the Trigger subsystem (see :TRIGger:TCONfigure command path).

With BUS selected, a GPIB bus trigger (GET or \*TRG) provides the pre-trigger event.

With MANUAL selected, pressing the front panel TRIG key provides the pre-trigger event.

**Program fragment**

```
PRINT #1, "output 16; :trac:feed:pret:sour bus; sour?" ' Select bus pre-trigger
PRINT #1, "enter 16" ' Get response from
 2002
```

**:CONTRol <name>**

:TRACe:FEED:CONTRol <name> Specify buffer control

**Parameters**

<name> =    NEVER        Disables buffer storage  
              NEXT        Fills buffer and stops  
              ALWAYS      Continuously stores readings in buffer  
              PRETrigger   Use Pretrigger mode to store readings

**Query** :CONTRol? Query buffer control

<b>Description</b>	<p>This command is used to select the buffer control. With NEVer selected, storage into the buffer is disabled. After cycling power, NEVer is selected. With any of the other selections, storage is performed as long as buffer feed is not set for NONE (see :TRACe:FEED NONE). When NEXT is selected, the storage process starts, fills the buffer and then stops. The buffer size is specified by the :POINts command.</p> <p>When ALWays is selected, the storage process starts and continues to store readings even after the buffer fills. After the buffer fills, readings overwrite the previously stored readings.</p> <p>When PRETrigger is selected, the buffer stores readings continuously (like ALWays) until the programmed pre-trigger event occurs. When the pre-trigger event occurs, the section of the buffer specified for post-trigger readings fill with new readings. The storage process stops when the post trigger portion of the buffer becomes full with new readings (see :TRACe:FEED:PRETrigger).</p>						
<b>Program fragment</b>	<pre>PRINT #1, "output 16; :trac:feed:cont next; cont?"      ' Fill buffer and stop PRINT #1, "enter 16"                                  ' Get response from 2002</pre>						
<b>3.22.6</b>	<p><b>:DATA?</b></p> <p>:TRACe:DATA?    Send buffer readings</p>						
<b>Description</b>	<p>When this command is sent and the Model 2002 is addressed to talk, all the readings stored in the buffer are sent to the computer. The format that readings are sent over the bus is controlled by the :FORMat subsystem.</p>						
<b>Program fragment</b>	<pre>PRINT #1, "output 16; :trac:data?"                    ' Read entire buffer PRINT #1, "enter 16"                                  ' Get readings from 2002</pre>						
<b>3.22.7</b>	<p><b>:TSTamp:FORMat &lt;name&gt;</b></p> <p>:TRACe:TSTamp:FORMat &lt;name&gt;    Select timestamp format</p>						
<b>Parameters</b>	<table border="0"> <tr> <td style="padding-right: 20px;">&lt;name&gt; =</td> <td>ABSolute</td> <td>Reference to first buffer reading</td> </tr> <tr> <td></td> <td>DELTA</td> <td>Time between buffer readings</td> </tr> </table>	<name> =	ABSolute	Reference to first buffer reading		DELTA	Time between buffer readings
<name> =	ABSolute	Reference to first buffer reading					
	DELTA	Time between buffer readings					
<b>Query</b>	:FORMat?    Query timestamp format						
<b>Description</b>	<p>This command is used to select the timestamp format for buffer readings. With ABSolute selected, each timestamp is referenced to the first reading stored in the buffer. With DELTA selected, timestamps provide the time between each buffer reading. See paragraphs 3.14 (:FORMat: ELEMents) and 3.21.14 (:SYSTem:TSTamp) for more information.</p>						
<b>Program fragment</b>	<pre>PRINT #1, "output 16; :trac:tst:form delt; form?"    ' Select DELTA timestamp and PRINT #1, "enter 16"                                  ' query                                                         ' Get response from 2002</pre>						



**Description**

These action commands are used to bypass the specified control source of the Trigger Model. They are used when you do not wish to wait for the programmed event. Note from the Trigger Model (Figure 3-13) that :arm:lay2:imm and :trig:imm also bypass the delay.

The instrument must be waiting for the appropriate event when this command is sent. Otherwise, an error occurs and the command is ignored. When the command is sent, the bypass occurs and operation continues on.

**Program fragment**

```
PRINT #1, "output 16; :trig:imm" ' Bypass measure control source
```

**3.23.4****:COUNT <n>**

```
:ARM[:SEquence[1]]:LAYer[1]:COUNT <n> Set arm layer count
:ARM[:SEquence[1]]:LAYer2:COUNT <n> Set scan layer count
:TRIGger[:SEquence[1]]:COUNT <n> Set measure layer count
```

**Parameters**

```
<n> = 1 to 99999 Specify count
 INF Sets count to infinite
 DEFault Sets count to 1
 MINimum Sets count to 1
 MAXimum Sets count to 99999
```

**Query**

```
:COUNT? Queries programmed count
:COUNT? DEFault Queries *RST default count
:COUNT? MINimum Queries lowest allowable count
:COUNT? MAXimum Queries largest allowable count
```

**Description**

These commands are used to specify how many times operation loops around in the specified layer of operation. For example, if the measure count is set to 10, operation continues to loop around in the measure layer until 10 measurements are performed. After the 10th measurement, operation proceeds back up to the scan layer.

**Program fragment**

```
PRINT #1, "output 16; :trig:coun 10; coun?" ' Set measure layer count
PRINT #1, "enter 16" ' Get response from 2002
```

**3.23.5****:DElay <n>**

```
:ARM[:SEquence[1]]:LAYer2:DElay <n> Set scan layer delay
:TRIGger[:SEquence[1]]:DElay <n> Set measure layer delay
```

**Parameters**

```
<n> = 0 to 999999.999 Specify delay in seconds
 DEFault 0 second delay
 MINimum 0 second delay
 MAXimum 999999.999 second delay
```

**Query**

```
:DElay? Query the programmed delay
:DElay? DEFault Query the *RST default delay
:DElay? MINimum Query the lowest allowable delay
:DElay? MAXimum Query the largest allowable delay
```

**Description**

These delay periods are used to delay operation in the specified layer. After the programmed event occurs, the instrument waits until the delay period expires before proceeding on in the Trigger Model. Note that the Arm Layer Arm Layer 1) does not use a delay.

**Program fragment**

```
PRINT #1, "output 16; :trig:del 1; del?" ' Set delay for measure layer
PRINT #1, "enter 16" ' Get response from 2002
```



**3.23.6 :SOURce <name>**

:ARM[:SEQUence[1]][:LAYer[1]]:SOURce <name> Specify arm event control source  
 :ARM[:SEQUence[1]][:LAYer2]:SOURce <name> Specify scan event control source  
 :TRIGger[:SEQUence[1]]:SOURce <name> Specify measure event control source

**Parameters**

<name> = HOLD Hold operation in specified layer  
 IMMEDIATE Pass operation through specified layer  
 RTCLock Select real-time clock as event (Arm Layer 1 only)  
 MANual Select manual event  
 BUS Select GPIB trigger as event  
 TLINK Select Trigger Link as event  
 EXTERNAL Select External Triggering as event  
 TIMER Select timer as event (not available for Arm Layer 1).

**Query**

:SOURce? Query programmed control source.

**Description**

These commands are used to select the event control source for the specified layer. With HOLD selected, operation stops and waits indefinitely in the specified layer. While in HOLD, operation can be continued by sending the :IMMEDIATE command or the :SIGNAL command. Keep in mind however, that if the layer count is >1, HOLD is again enforced when operation loops back around.

With IMMEDIATE selected (do not confuse :SOURce IMMEDIATE with :IMMEDIATE), operation immediately passes through the specified layer.

A specific event can be used to control operation through a layer. With BUS selected, operation continues when a GPIB trigger (GET or \*TRG) is sent. With TLINK selected, operation continues when an input trigger via the Trigger Link is received. With EXTERNAL selected, operation continues when an External Trigger is received.

A real-time clock event is available for the arm layer (Arm Layer 1). With RTCLock selected, event detection is satisfied at the programmed date and time allowing operation to continue on in the Trigger Model. See paragraph 3.23.10 to set the date and time for the RTCLock control source.

A TIMER event is available for the scan and measure layers. With TIMER selected for the specified layer, the event occurs at the beginning of the timer interval, and every time it times out. For example, if the measure layer timer is programmed for a 30 second interval, the first pass through the measure layer control source occurs immediately. Subsequent scan events will then occur every 30 seconds. The interval for the timer is set using the :TIMER command.

**Program fragment**

```
PRINT #1, "output 16; :trig:sour imm; sour?" ' Set measure control source
PRINT #1, "enter 16" ' Get response from 2002
```

**3.23.7 :TIMER <n>**

:ARM[:SEQUence[1]][:LAYer2]:TIMER <n> Set interval for scan layer timer  
 :TRIGger[:SEQUence[1]]:TIMER <n> Set interval for measure layer timer

**Parameters**

<n> = 0.001 to 999999.999 Specify timer interval in seconds  
 DEFault 0.1 second  
 MINimum 0.001 second  
 MAXimum 999999.999 seconds

<b>Query</b>	:TiMer?	Query programmed timer interval
	:TiMer? DEFault	Query *RST default timer interval
	:TiMer? MINimum	Query lowest allowable timer interval
	:TiMer? MAXimum	Query largest allowable timer interval

**Description**

These commands are used to set the interval for the scan layer and measure layer timers. Note that the timer is in effect only if the timer is the selected control source. Also, note that the arm layer (Arm Layer 1) does not use a timer.

**Program fragment**

```
PRINT #1, "output 16; :trig:tim .25; tim?" ' Set timer for Measure Layer
PRINT #1, "enter 16" ' Get response from 2002
```

**3.23.8****:SiGNal**

:ARM[:SEquence[1]][:LAYer[1]]:SiGNal	Bypass arm control source
:ARM[:SEquence[1]]:LAYer2:SiGNal	Bypass scan control source
:TRIGger[:SEquence[1]]:SiGNal	Bypass measure control source

**Description**

These action commands are used to bypass the specified control source and also when you do not wish to wait for the programmed event. Keep in mind that the instrument must be waiting for the appropriate event when the command is sent. Otherwise, an error occurs and this command is ignored.

**Program fragment**

```
PRINT #1, "output 16; :trig:sign" ' Bypass measure control source
```

**3.23.9****TCONfigure commands****:PROTocol <name>**

:TRIGger[:SEquence[1]]:TCONfigure:PROTocol <name> Specify Trigger Link protocol

**Parameters**

<name> =	ASYNchronous	Asynchronous Trigger Link mode
	SSYNchronous	Semi-synchronous Trigger Link mode

**Query**

:PROTocol? Query programmed Trigger Link protocol

**Description**

This command is used to select the protocol for the measure layer Trigger Link. With ASYNchronous selected, separate trigger lines are used for input and output triggers. With SSYNchronous selected, a single trigger line is used for both input and output triggers.

Note that the arm and scan layers only use the asynchronous Trigger Link mode and therefore, do not have to be selected.

**Program fragment**

```
PRINT #1, "output 16; :trig:tcon:prot ssyn; prot?" ' Select semi-sync proto-
 col
PRINT #1, "enter 16" ' Get response from 2002
```

**:DIRection <name>**

:ARM[:SEquence[1]][:LAYer[1]]:TCONfigure:DIRection <name>	Control arm Source Bypass
:ARM[:SEquence[1]]:LAYer2:TCONfigure:DIRection <name>	Control scan Source Bypass
:TRIGger[:SEquence[1]]:TCONfigure:DIRection <name>	Control measure Source Bypass

**Parameters**

<name> =	SOURce	Enable Source Bypass
	ACCEptor	Disable Source Bypass

**Query**

:DIRrection? Query Source Bypass state

**Description**

When a source bypass is enabled and the External or Trigger Link control source is selected, operation loops around the appropriate control source on the initial pass through that layer. Note that the source bypass for the scan and measure layers also loops around the delay.

If programmed for another pass through the specified layer (count >1), the bypass loop is not in effect even though it is still enabled. The bypass loop will be in effect if operation first goes back into the previous layer (or idle).

Enabling the Source Bypass for the arm and scan layers also enables their output triggers. When operation leaves the arm or scan layer, the appropriate output trigger pulse occurs. If the Trigger Link (TLINK) control source is selected, the output trigger is available on the programmed Trigger Link output line. For all other control source selections, the output trigger pulse is available at the METER COMPLETE Output connector. The output trigger in these two layers is disabled when the source bypass is disabled.

The output trigger in the measure layer is always enabled and occurs after the device action.

With ACceptor selected, the bypass is disabled, This simply means that operation will not proceed through the specified layer until the appropriate event occurs.

**Program fragment**

```
PRINT #1, "output 16; :trig:tcon:dir sour; dir?" ' Enable measure source
 bypass
PRINT #1, "enter 16" ' Get response from 2002
```

**:ASYNchronous commands****:ILINe <NRf>**

```
:ARM[:SEQUence[1]][:LAYer[1]]:TCONfigure:ASYNchronous:ILINe <NRf> Select input trigger line; arm
 layer
:ARM[:SEQUence[1]][:LAYer2]:TCONfigure:ASYNchronous:ILINe <NRf> Select input trigger line; scan
 layer
:TRIGger[:SEQUence[1]]:TCONfigure:ASYNchronous:ILINe <NRf> Select input trigger line; mea-
 sure layer
```

**Parameters**

```
<NRf> = 1 Line #1 <NRf> = 4 Line #4
 2 Line #2 5 Line #5
 3 Line #3 6 Line #6
```

**Query**

:ILINe? Query programmed input line #

**Description**

These commands are used to select an input line for the asynchronous Trigger Link of the specified layer. Keep in mind that asynchronous Trigger Link input and output (see :OLINe) cannot share the same line. If you assign the input to a line that is already being used for the output, an error occurs and the command is ignored.

**Program fragment**

```
PRINT #1, "output 16; :trig:tcon:asyn:ilin 3; inlin?" ' Select input line
PRINT #1, "enter 16" ' Get response from 2002
```

**:OLINe <NRf>**

:ARM[:SEQuence[1]][:LAYer[1]]:TCONfigure:ASYNchronous:OLINe <NRf> Select output trigger line; arm layer  
 :ARM[:SEQuence[1]][:LAYer2]:TCONfigure:ASYNchronous:OLINe <NRf> Select output trigger line; scan layer  
 :TRIGger[:SEQuence[1]]:TCONfigure:ASYNchronous:OLINe <NRf> Select output trigger line; measure layer

**Parameters**

<NRf> = 1	Line #1	<NRf> = 4	Line #4
2	Line #2	5	Line #5
3	Line #3	6	Line #6

**Query**

:OLINe? Query programmed output line #

**Description**

These commands are used to select an output line for the asynchronous Trigger Link of the specified layer. Keep in mind that asynchronous Trigger Link input and output cannot share the same line. If you assign the output to a line that is already being used for the input, an error occurs and the command is ignored.

**Program fragment**

```
PRINT #1, "output 16; :trig:tcon:asyn:olin 4; olin?" ' Select output line
PRINT #1, "enter 16" ' Get response from 2002
```

**:SSYNchronousLINE <NRf>**

:TRIGger[:SEQuence[1]]:TCONfigure:SSYNchronous:LINE <NRf> Specify semi-synchronous Trigger Link line for measure layer

**Parameters**

<NRf> = 1	Line #1	<NRf> = 4	Line #4
2	Line #2	5	Line #5
3	Line #3	6	Line #6

**Query**

:LINE? Query programmed output line #

**Description**

This command is used to select one of the six trigger lines for the semi-synchronous Trigger Link.

**Program fragment**

```
PRINT #1, "output 16; :trig:tcon:ssyn:line 6; line?" ' Select Trigger Link line
PRINT #1, "enter 16" ' Get response from 2002
```

**3.23.10****RTCLock commands**

The following commands are used to specify the date and time for the RTCLock control source (see paragraph 3.23.6 for details).

**:DATE<yr>, <mo>, <day>**

:ARM[:SEQuence[1]][:LAYer[]]:RTCLock:DATE <yr>, <mo>, <day> Set date for RTCLock control source

**Parameters**

<yr> =	1993 to 2092	Specify year
<mo> =	1 to 12	Specify month
<day> =	1 to 31	Specify day

**Query**

:DATE? Query the date

**Description**

This command is used to set the date for the RTCLock control source. Setting an invalid date (i.e. February 29, 1994) for the clock event results in an error and the previous date is retained.

**Program fragment**

```
PRINT #1, "output 16; :arm:rtcl:date <1993>, <12>, <1>; date?"
PRINT #1, "enter 16"
```

' Set date to December 1, 1993 and query  
' Get response message from 2002

**:TIME<hr>, <min>, <sec>**

:ARM[:SEQUence[1]][LAYER[]]:RTCLock:TIME <hr>, <min>, <sec>     Set time for RTCLock control source

**Parameters**

<hr> =     0 to 23             Specify hour (24 hour format)  
 <min> =    0 to 59            Specify minute  
 <sec> =    0.00 to 59.99      Specify second (round to 1/100 sec.)

**Query**

:DATE?     Query the time

**Description**

This command is used to set the time for the RTCLock control source. Note that the time must be set using the 24-hour format (i.e. hour 13 is 1pm). Setting an invalid time results in an error and the previous time is retained.

:TIME? returns the time to nearest hundredth of a second.

**Program fragment**

```
PRINT #1, "output 16; :arm:rtcl:time <14>, <36>, <0>; time?"
PRINT #1, "enter 16"
```

' Set time to 2:36 pm and query  
' Get response message from 2002

### 3.24 :UNIT subsystem

The UNIT subsystem is used to configure and control the measurement units for TEMP and ACV, and is summarized in Table 3-16.

#### **:TEMPerature <name>**

:UNIT:TEMPerature <name> Specify TEMP units

#### Parameters

<name> = C or CEL °C temperature units  
 F or FAR °F temperature units  
 K K temperature units

#### Query

TEMPerature? Query temperature units

#### Description

This command is used to specify the units for temperature measurements.

#### Program fragment

```
PRINT #1, "output 16; :unit:temp f; temp?" ' Select °F for TEMP
PRINT #1, "enter 16" ' Get response message from 2002
```

#### **:AC <name>**

:UNIT:VOLTage:AC <name> Specify ACV units

<name> = V AC voltage measurement units  
 DB dB AC voltage measurement units  
 DBM dBm AC voltage measurement units

#### Query

:AC? Query AC voltage units

#### Description

This command is used to select the units for ACV measurements. With volt (V) units selected, normal AC voltage measurements are made for the ACV function. With DB units selected, AC dB voltage measurements are performed. The DBM units selection is used to make decibel measurements referenced to 1mW. dB and dBm measurements are explained in paragraph 2.4.1 (UNITS).

#### Program fragment

```
PRINT #1, "output 16; :unit:volt:ac db; ac?" ' Select dB units for ACV
PRINT #1, "enter 16" ' Get response message from 2002
```

#### **:DB:REference <n>**

:UNIT:VOLTage:AC:DB:REference <n> Specify dBm reference

#### Parameters

<n> = 0.001 to 750 Specify reference in volts  
 DEFault 1V reference  
 MINimum 0.001V reference  
 MAXimum 750V reference

#### Query

:REference?  
 :REference? DEFault  
 :REference? MINimum  
 :REference? MAXimum

**Description**

This command is used to specify the dB reference level. When DB units is selected (:VOLTage:AC:DB), ACV db measurements are made using the specified dB reference level.

The reference level is specified in volts and is not range dependent. For example, a dB reference level of 1 is 1V on all ACV measurement ranges.

**Program fragment**

```
PRINT #1, "output 16; :unit:volt:ac:db:ref 2; ref?" ' Set dB reference
PRINT #1, "enter 16" ' Get response message
 from 2002
```

**:DBM:IMPedance <n>**

:UNIT:VOLTage:AC:DBM:IMPedance <n> Specify dB reference

**Parameters**

<n> = 1 to 9999 Specify reference impedance

**Query**

```
:IMPedance?
:IMPedance? DEFault
:IMPedance? MINimum
:IMPedance? MAXimum
```

**Description**

This command is used to specify the dBm reference impedance level. When dBm units is selected ACV dBm measurements are made using the specified dBm reference impedance.

The reference impedance is specified in ohms and is not range dependent. For example, a dBm reference level of 600 is 600Ω on all ACV measurement ranges. A rational number is rounded to the nearest valid integer value.

**Program fragment**

```
PRINT #1, "output 16; :unit:volt:ac:dbm:imp 600; imp?" ' Select dBm impedance
PRINT #1, "enter 16" ' Get response message
 from 2002
```

# A

## Specifications

---



**Keithley Instruments, Inc.**  
 28775 Aurora Road  
 Cleveland, Ohio 44139  
 1-888-KEITHLEY  
 www.keithley.com

The following pages contain the complete specifications for the 2002. Every effort has been made to make these specifications complete by characterizing its performance under the variety of conditions often encountered in production, engineering, and research.

The 2002 provides Transfer, 24-hour, 90-day, 1-year, and 2-year specifications, with full specifications for the 90-day, 1-year, and 2-year intervals. This allows the operator to utilize 90-day, 1-year, or 2-year recommended calibration intervals, depending upon the level of accuracy desired. As a general rule, the 2002's 2-year performance exceeds a 6H-digit DMM's 90-day, 180-day, or 1-year specifications.

### ABSOLUTE ACCURACY

All DC specifications are given as relative accuracies. To obtain absolute accuracies, the absolute uncertainties of the calibration sources must be added to the relative accuracies. The absolute uncertainties for the calibration sources used during Keithley's factory calibration are given in a table included in the specifications. The uncertainties of the operator's sources may be different.

All AC specifications are given as absolute accuracies.

### TYPICAL ACCURACIES

Accuracy can be specified as typical or warranted. All specifications shown are warranted unless specifically noted. Almost 99% of the 2002's specifications are warranted specifications. In some cases it is not possible to obtain sources to maintain traceability on the performance of every unit in production on some measurements (e.g., high-voltage, high-frequency signal sources with sufficient accuracy do not exist). These values are listed as typical.

### 2002 SPECIFIED CALIBRATION INTERVALS

Measurement Function	24 Hour <sup>1</sup>	90 Day <sup>2</sup>	1 Year <sup>2</sup>	2 Year <sup>2</sup>
DC Volts	•	•	•	•
DC Volts Peak Spikes		•	•	•
AC Volts rms		• <sup>3</sup>	• <sup>3</sup>	• <sup>3</sup>
AC Volts Peak		•	•	•
AC Volts Average		• <sup>3</sup>	• <sup>3</sup>	• <sup>3</sup>
AC Volts Crest Factor		•	•	•
Ohms	•	•	•	•
DC Current	•	•	•	•
DC In-Circuit Current		•	•	•
AC Current		•	•	•
Frequency		•	•	•
Temperature (Thermocouple)		•	•	•
Temperature (RTD)	•	•	•	•

## DC VOLTS

### DCV INPUT CHARACTERISTICS AND ACCURACY

#### Enhanced Accuracy<sup>4</sup> – 10PLC, DFILT 10

Range	Full Scale	Resolution	Input Resistance	Relative Accuracy ±(ppm of reading + ppm of range)					Temperature Coefficient ±(ppm of reading + ppm of range)/°C Outside TCAL ±5°C
				Transfer <sup>5</sup>	24 Hours <sup>6</sup>	90 Days <sup>7</sup>	1 Year <sup>7</sup>	2 Years <sup>7</sup>	
200 mV <sup>8</sup>	±210.000000	1 nV	>100 GΩ	0.4 + 1.5	3.5 + 3	15 + 8	19 + 9	23 + 10	2 + 1.8
2 V <sup>8</sup>	±2.10000000	10 nV	>100 GΩ	0.2 + 0.15	1.2 + 0.3	6 + 0.8	10 + 0.9	14 + 1	0.2 + 0.18
20 V	±21.00000000	100 nV	>100 GΩ	0.1 + 0.05	1.2 + 0.1	6 + 0.15	10 + 0.15	14 + 0.15	0.3 + 0.02
200 V	±210.000000	1 μV	10 MΩ ±1%	0.5 + 0.08	5 + 0.4	14 + 2	22 + 2	30 + 2	1.5 + 0.3
1000 V <sup>9</sup>	±1100.000000	10 μV	10 MΩ ±1%	1 + 0.05	5 + 0.08	14 + 0.4	22 + 0.4	30 + 0.4	1.5 + 0.06

<sup>1</sup> For T<sub>CAL</sub> ±1°C.

<sup>2</sup> For T<sub>CAL</sub> ±5°C.

<sup>3</sup> For ±2°C of last AC self-cal.

<sup>4</sup> Specifications are for 10 power line cycles, synchronous autozero, 10-reading repeat digital filter, autorange off, except as noted.

<sup>5</sup> Specifications apply for 20-reading repeat digital filter, TREF ± 0.5°C (TREF is the initial ambient temperature), and for measurements within 10% of the initial measurement value and within 10 minutes of the initial measurement time.

<sup>6</sup> For T<sub>CAL</sub> ±1°C, following 4-hour warm-up. TCAL is ambient temperature at calibration (23°C at the factory). Add 0.5 ppm of reading uncertainty if the unit is power cycled during this interval.

<sup>7</sup> For T<sub>CAL</sub> ±5°C, following 4-hour warm-up.

<sup>8</sup> Care must be taken to minimize thermal offsets due to operator cables.

<sup>9</sup> Add 20ppm × (VIN/1000V)<sup>2</sup> additional uncertainty for inputs above 200V, except in transfer accuracy specifications

Keithley Instruments, Inc.  
28775 Aurora Road  
Cleveland, Ohio 44139  
1-888-KEITHLEY  
www.keithley.com

**DC Voltage Uncertainty:** =  $\pm [ (\text{ppm of reading}) \times (\text{measured value}) + (\text{ppm of range}) \times (\text{range used}) ] / 1,000,000$ .

**% Accuracy:** = (ppm accuracy) / 10,000.

**1ppm of Range:** = 20 counts for ranges up to 200V and 10 counts on 1000V range at 7H digits.

#### NORMAL ACCURACY<sup>10</sup> – 1PLC, DFILT OFF

Range	Full Scale	Resolution	Input Resistance	Relative Accuracy $\pm$ (ppm of reading + ppm of range)				Temperature Coefficient $\pm$ (ppm of reading + ppm of range)/°C Outside T <sub>CAL</sub> $\pm$ 5°C
				24 Hours <sup>6</sup>	90 Days <sup>7</sup>	1 Year <sup>7</sup>	2 Years <sup>7</sup>	
200 mV <sup>8</sup>	$\pm 210.00000$	10 nV	>100 G $\Omega$	3.5 + 6	15 + 11	19 + 12	23 + 13	2 + 1.8
2 V <sup>8</sup>	$\pm 2.1000000$	100 nV	>100 G $\Omega$	1.2 + 0.6	6 + 1.1	10 + 1.2	14 + 1.3	0.2 + 0.18
20 V	$\pm 21.000000$	1 $\mu$ V	>100 G $\Omega$	3.2 + 0.35	8 + 0.4	12 + 0.4	16 + 0.4	0.3 + 0.02
200 V	$\pm 210.00000$	10 $\mu$ V	10 M $\Omega$ $\pm$ 1%	5 + 1.2	14 + 2.8	22 + 2.8	30 + 2.8	1.5 + 0.3
1000 V <sup>9</sup>	$\pm 1100.0000$	100 $\mu$ V	10 M $\Omega$ $\pm$ 1%	5 + 0.4	14 + 0.7	22 + 0.7	30 + 0.7	1.5 + 0.06

#### SPEED AND ACCURACY 90 DAYS

**Accuracy<sup>4,11</sup>**  
 **$\pm$ (ppm of reading + ppm of range + rms noise<sup>12</sup>)**

Range	10PLC DFILT On, 10 Readings	10PLC DFILT Off	1PLC DFILT On, 10 Readings	1PLC DFILT Off	0.1PLC DFILT Off	0.01PLC <sup>13</sup> DFILT Off
200 mV <sup>8</sup>	15 + 8 + 0	15 + 8 + 0.5	15 + 8 + 0.7	15 + 8 + 1	25 + 10 + 13	100 + 200 + 15
2 V <sup>8</sup>	6 + 0.8 + 0	6 + 0.8 + 0.05	6 + 0.8 + 0.07	6 + 0.8 + 0.1	7 + 1 + 1.3	130 + 200 + 3
20 V	6 + 0.15 + 0	6 + 0.15 + 0.03	7 + 0.15 + 0.05	8 + 0.15 + 0.08	15 + 0.5 + 0.7	130 + 200 + 3
200 V	14 + 2 + 0	14 + 2 + 0.1	14 + 2 + 0.15	14 + 2 + 0.25	15 + 2 + 1	130 + 200 + 3
1000 V <sup>9</sup>	14 + 0.4 + 0	14 + 0.4 + 0.05	14 + 0.4 + 0.05	14 + 0.4 + 0.1	15 + 0.5 + 0.5	90 + 200 + 2

PLC = Power Line Cycles. DFILT = Digital Filter.

#### NOISE REJECTION (DB)<sup>14</sup>

Speed (Number of Power Line Cycles)	AC and DC CMRR <sup>15</sup>		AC NMRR		Internal Trigger DFILT Off
	Line Sync On <sup>16</sup>	Internal Trigger	Line Sync On <sup>16,25</sup> Readings DFILT On	Line Sync On <sup>16</sup> DFILT Off	
PLC $\geq$ 1	140	120	90	80	60
PLC < 1	90	60	60	50	0

Effective noise is reduced by a factor of 10 for every 20dB of noise rejection (140dB reduces effective noise by 10,000,000:1).

CMRR is rejection of undesirable AC or DC signal between LO and earth. NMRR is rejection of undesirable power line related AC signal between HI and LO.

#### KEITHLEY FACTORY CALIBRATION UNCERTAINTY

Range	ppm of reading
200	mV 3.2
2	V 3.2
20	V 2.6
200	V 2.6
1000	V 2.6

Factory calibration uncertainty represents traceability to NIST. This uncertainty is added to relative accuracy specifications to obtain absolute accuracies. The 200mV and 2V range uncertainties are equal to the uncertainty of the 2V calibration source. The 20V, 200V, and 1000V range uncertainties are equal to the uncertainty of the 20V calibration source.

<sup>10</sup> Specifications are for 1 power line cycle, normal autozero, digital filter off, autorange off.

<sup>11</sup> For TCAL  $\pm$ 5°C, normal autozero. 1-year or 2-year accuracy can be found by applying the same speed accuracy ppm changes to the 1-year or 2-year base accuracy.

<sup>12</sup> Typical values. Peak-to-peak noise equals 6 times rms noise.

<sup>13</sup> In burst mode, display off. Burst mode requires autozero refresh (by changing resolution or measurement function) once every 24 hours.

<sup>14</sup> For line frequency  $\pm$ 0.1%.

<sup>15</sup> Applies for 1k $\Omega$  imbalance in the LO lead. For 400Hz operation, subtract 10dB. For the 200V and 1000V ranges, subtract 20dB.

<sup>16</sup> For noise synchronous to the line frequency.

Keithley Instruments, Inc.  
28775 Aurora Road  
Cleveland, Ohio 44139  
1-888-KEITHLEY  
www.keithley.com

#### DCV READING RATES<sup>12,17</sup>

PLC	Measurement Aperture	Bits	Default Digits	Readings/Second to Memory		Readings/Second to IEEE-488 <sup>18</sup>		Readings/Second with Time Stamp to IEEE-488 <sup>18</sup>	
				Autozero Off	Autozero On	Autozero Off	Autozero On	Autozero Off	Autozero On
10	167 ms (200 ms)	29	8½	6 (5)	2 (1.7)	6 (5)	2 (1.6)	6 (5)	2 (1.6)
2	33.4 ms (40 ms)	27	7½	29 (25)	9 (7.6)	29 (24)	9 (7.4)	27 (22)	9 (7.4)
1	16.7 ms (20 ms)	26	7½	56 (48)	47 (40)	55 (45)	46 (38)	50 (41)	42 (34)
0.2	3.34 ms (4 ms)	23	6½	235 (209)	154 (137)	225 (200)	146 (130)	152 (135)	118 (105)
0.1	1.67 ms (2 ms)	22	6½	318 (305)	173 (166)	308 (295)	168 (161)	181 (174)	121 (116)
0.02	334 µs (400 µs)	20	5½	325 (325)	179 (179)	308 (308)	173 (173)	182 (182)	124 (124)
0.01	167 µs (167 µs)	19	4½	390 (390)	186 (186)	365 (365)	182 (182)	201 (201)	125 (125)
0.01 <sup>11</sup>	167 µs (167 µs)	19	4½	2000 (2000)			2000 (2000)		

**Linearity:** <0.1ppm of range typical, <0.2ppm maximum.

**Zero Stability:** Typical maximum variation in 1 hour, T<sub>REF</sub> ± 0.5°C, 7H-digit resolution, 10-reading digital filter, synchronous autozero.

Range	1 PLC	10 PLC
200 mV <sup>4</sup>	± 60 counts	± 40 counts
2 V <sup>4</sup>	± 6 counts	± 4 counts
20 V	± 4 counts	± 1 count
200 V	± 5 counts	± 2 counts
1000 V	± 2 counts	± 1 count

**Polarity Reversal Error:** This is the portion of the instrument error that is seen when HI and LO are reversed. This is not an additional error—it is included in the overall instrument accuracy specification.

**Reversal Error:** <4 counts at 10V input at 7H digits, 10 power line cycles, synchronous autozero, 10-reading repeat digital filter.

**Input Bias Current:** <100pA at 25°C.

**Settling Characteristics:** <50µs to 10ppm of step size for the 200mV–20V ranges. <1ms to 10ppm of step size for the 200V and 1000V ranges. Reading settling times are affected by source impedance and cable dielectric absorption characteristics.

**Autoranging:** Autoranges up at 105% of range, down at 10% of range.

#### DCV PEAK SPIKES MEASUREMENT

**REPETITIVE SPIKES ACCURACY<sup>19</sup>** 90 Days, 1 Year or 2 Years, T<sub>CAL</sub> ±5°C ±(% of reading+% of range)

Range	0–1kHz <sup>20</sup>	1kHz–10kHz	10kHz–30kHz	30kHz–50kHz	50kHz–100kHz	100kHz–300kHz	300kHz–500kHz	500kHz–750kHz	750kHz–1MHz	Temperature Coefficient ±(% of reading +% of range)/°C Outside TCAL ±5°C
200 mV	0.08+0.7	0.09+0.7	0.1 +0.7	0.15+0.7	0.25+0.7	1.0+0.7	2.5+0.7	5.5+0.7	9+0.7	0.002+0.03
2 V	0.08+0.3	0.09+0.3	0.1 +0.3	0.15+0.3	0.25+0.3	1.0+0.3	2.5+0.3	5.5+0.3	9+0.3	0.002+0.03
20 V	0.1 +0.7	0.11+0.7	0.14+0.7	0.19+0.7	0.25+0.7	1.0+0.7	2.5+0.7	5.5+0.7	9+0.7	0.004+0.03
200 V <sup>21</sup>	0.1 +0.3	0.11+0.3	0.14+0.3	0.19+0.3	0.25+0.3	1.0+0.3 <sup>22</sup>	2.5+0.3 <sup>22</sup>	5.5+0.3 <sup>22</sup>	9+0.3 <sup>22</sup>	0.004+0.03
1000 V <sup>21</sup>	0.12+0.6	0.16+0.6	0.2 +0.6	0.25+0.6 <sup>22</sup>	0.5 +0.6 <sup>22</sup>					0.01 +0.02
Max. % of Range	±125%	±125%	±125%	±125%	±125%	±125%	±125%	±100%	±75%	

#### Default Measurement

**Resolution:** 3H digits.

**Maximum Input:** ±1100V peak value, 2x10<sup>7</sup>V·Hz (for inputs above 20V).

**Non-Repetitive Spikes:** 10% of range per µs typical slew rate.

**Spike Width:** Specifications apply for spikes ≥1µs.

**Range Control:** In Multiple Display mode, voltage range is the same as DCV range.

**Spikes Measurement Window:** Default is 100ms per reading (settable from 0.1 to 9.9s in Primary Display mode).

**Input Characteristics:** Same as ACV input characteristics.

**Spikes Display:** Access as multiple display on DC Volts. First option presents positive peak spikes and highest spike since reset. Second option presents negative spikes and lowest spike. Highest and lowest spike can be reset by pressing DCV function button. Third option displays the maximum and minimum levels of the input signal. Spikes displays are also available through CONFIG-ACV-ACTYPE as primary displays.

<sup>17</sup> For on-scale readings, no trigger delays, internal trigger, digital filter off, normal autozero, display off, SREAL format. These rates are for 60Hz and (50Hz). Rates for 400Hz equal those for 50Hz.

<sup>18</sup> Using Internal Buffer.

<sup>19</sup> Specifications apply for sine wave input with a 10-reading digital filter. If no filter is used, add 0.25% of range typical uncertainty.

<sup>20</sup> Specifications assume AC+DC coupling for frequencies below 200Hz. Below 20Hz add 0.1% of reading additional uncertainty.

<sup>21</sup> Add 0.001% of reading × (VIN/100V)<sup>2</sup> additional uncertainty for inputs above 100V.

<sup>22</sup> Typical values.

Keithley Instruments, Inc.  
28775 Aurora Road  
Cleveland, Ohio 44139  
1-888-KEITHLEY  
www.keithley.com

## AC VOLTS

### ACV INPUT CHARACTERISTICS

Rms Range	Peak Input	Full Scale rms	Resolution	Input Impedance	Temperature Coefficient <sup>23</sup> ±(% of reading + % of range) / °C Outside T <sub>CAL</sub> ±5°C
200 mV	1 V	210.0000	100 nV	1MΩ ±2% with <140pF	0.004 + 0.001
2 V	8 V	2.100000	1 μV	1MΩ ±2% with <140pF	0.004 + 0.001
20 V	100 V	21.000000	10 μV	1MΩ ±2% with <140pF	0.006 + 0.001
200 V	800 V	210.0000	100 μV	1MΩ ±2% with <140pF	0.006 + 0.001
750 V	1100 V	775.0000	1 mV	1MΩ ±2% with <140pF	0.012 + 0.001

**AC Voltage Uncertainty** = ±[ (% of reading) x (measured value) + (% of range) x (range used) ] / 100.

**PPM Accuracy** = (% accuracy) x 10,000.

**0.015% of Range** = 30 counts for ranges up to 200V and 113 counts on 750V range at 5H digits.

**LOW FREQUENCY MODE RMS<sup>24</sup>** 90 Days, 1 Year or 2 Years, ±2°C from last AC self-cal, for 1% to 100% of range<sup>25</sup>, ±(% of reading + % of range)

Range	1–10Hz <sup>22</sup>	10–50Hz	50–499Hz	501Hz–2kHz	2–10kHz	10–30kHz	30–50kHz	50–100kHz	100–200kHz	0.2–1MHz	1–2MHz
200 mV	0.09+0.015	0.06+0.015	0.035+0.015	0.03+0.02	0.02+0.02	0.025+0.02	0.05+0.02	0.3+0.015	0.75+0.025	2+0.1	5+0.2
2 V	0.09+0.015	0.04+0.015	0.025+0.015	0.02+0.02	0.02+0.02	0.025+0.02	0.05+0.02	0.3+0.015	0.75+0.025	2+0.1	5+0.2
20 V	0.1 +0.015	0.06+0.015	0.035+0.015	0.03+0.015	0.04+0.015	0.05 +0.015	0.07+0.015	0.3+0.015	0.75+0.025	4+0.2	7+0.2 <sup>22</sup>
200 V <sup>21</sup>	0.1 +0.015	0.05+0.015	0.03 +0.015	0.03+0.015	0.04+0.015	0.05 +0.015	0.07+0.015	0.3+0.015	0.75+0.025 <sup>22</sup>	4+0.2 <sup>22</sup>	
750 V <sup>21</sup>	0.13+0.015	0.09+0.015	0.05 +0.015	0.05+0.015	0.06+0.015	0.08 +0.015	0.1 +0.015 <sup>22</sup>	0.5+0.015 <sup>22</sup>			

**NORMAL MODE RMS<sup>24</sup>** 90 Days, 1 Year or 2 Years, ±2°C from last AC self-cal, for 1% to 100% of range<sup>25</sup>, ±(% of reading + % of range)

Range	20–50Hz	50–100Hz	0.1–2kHz	2–10kHz	10–30kHz	30–50kHz	50–100kHz	100–200kHz	0.2–1MHz	1–2MHz
200 mV	0.25+0.015	0.07+0.015	0.02+0.02	0.02+0.02	0.025+0.02	0.05+0.02	0.3+0.015	0.75+0.025	2+0.1	5+0.2
2 V	0.25+0.015	0.07+0.015	0.02+0.02	0.02+0.02	0.025+0.02	0.05+0.02	0.3+0.015	0.75+0.025	2+0.1	5+0.2
20 V	0.25+0.015	0.07+0.015	0.03+0.015	0.04+0.015	0.05 +0.015	0.07+0.015	0.3+0.015	0.75+0.025	4+0.2	7+0.2 <sup>22</sup>
200 V <sup>21</sup>	0.25+0.015	0.07+0.015	0.03+0.015	0.04+0.015	0.05 +0.015	0.07+0.015	0.3+0.015	0.75+0.025 <sup>22</sup>	4+0.2 <sup>22</sup>	
750 V <sup>21</sup>	0.25+0.015	0.1 +0.015	0.05+0.015	0.06+0.015	0.08 +0.015	0.1 +0.015 <sup>22</sup>	0.5+0.015 <sup>22</sup>			

**dB ACCURACY RMS** ±dB, 90 Days, 1 Year or 2 Years, TCAL ±5°C, Reference=1V, Autoranging, Low Frequency Mode, AC+DC Coupling

Input	1–100Hz	0.1–30kHz	30–100kHz	100–200kHz	0.2–1MHz	1–2MHz
–54 to –40 dB (2 mV to 10 mV)	0.230	0.225	0.236	0.355		
–40 to –34 dB (10 mV to 20 mV)	0.036	0.031	0.041	0.088		
–34 to 6 dB (20 mV to 2 V)	0.023	0.018	0.028	0.066	0.265	0.630
6 to 26 dB (2 V to 20 V)	0.024	0.024	0.028	0.066	0.538	0.820 <sup>22</sup>
26 to 46 dB (20 V to 200 V)	0.024	0.024	0.028	0.066 <sup>22</sup>	0.538 <sup>22</sup>	
46 to 57.8 dB (200 V to 775 V)	0.018	0.021	0.049 <sup>22</sup>			

### ACV READING RATES<sup>17, 22</sup>

PLC	Measurement Aperture	Bits	Default Digits	Readings/Second to Memory		Readings/Second to IEEE-488 <sup>18</sup>		Readings/Second with Time Stamp to IEEE-488 <sup>18</sup>	
				Autozero Off	Autozero On	Autozero Off	Autozero On	Autozero Off	Autozero On
10	167 ms (200 ms)	29	6H	6 (5)	2 (1.7)	6 (5)	2 (1.6)	6 (5)	2 (1.6)
2	33.4 ms (40 ms)	27	5H	29 (25)	9 (7.6)	28 (23)	9 (7.4)	26 (21)	9 (7.4)
1	16.7 ms (20 ms)	26	5H	56 (48)	47 (40)	52 (43)	44 (36)	48 (39)	40 (33)
0.2	3.34 ms (4 ms)	23	5H	145 (129)	110 (98)	131 (117)	100 (88)	102 (91)	79 (70)
0.1	1.67 ms (2 ms)	22	5H	150 (144)	112 (108)	132 (127)	101 (97)	102 (98)	80 (77)
0.02	334 μs (400 μs)	20	5H	150 (150)	115 (115)	132 (132)	103 (103)	102 (102)	80 (80)
0.01	167 μs (167 μs)	19	4H	382 (382)	116 (116)	251 (251)	103 (103)	163 (163)	80 (80)
0.01 <sup>13</sup>	167 μs (167 μs)	19	4H	2000 (2000)		2000 (2000)			

<sup>23</sup> Temperature coefficient applies to rms and average readings. For frequencies above 100kHz, add 0.01% of reading/°C to temperature coefficient.

<sup>24</sup> Specifications apply for sinewave input, AC + DC coupling, 1 power line cycle, autozero on, digital filter off, following 55-minute warm-up.

<sup>25</sup> For 1% to 5% of range below 750V range, and for 1% to 7% of 750V range, add 0.01% of range uncertainty. For inputs from 200kHz to 2MHz, specifications apply above 10% of range.

Keithley Instruments, Inc.  
28775 Aurora Road  
Cleveland, Ohio 44139  
1-888-KEITHLEY  
www.keithley.com

### ACV CREST FACTOR MEASUREMENT<sup>26</sup>

**Crest Factor:** = Peak AC / rms AC.  
**Crest Factor Resolution:** 3 digits.  
**Crest Factor Accuracy:** Peak AC uncertainty + AC normal mode rms uncertainty.  
**Measurement Time:** 100ms plus rms measurement time.  
**Input Characteristics:** Same as ACV input.  
**Crest Factor Frequency Range:** 20Hz – 1MHz.  
**Crest Factor Display:** Access as multiple display on AC volts.

### AC COUPLING

For AC only coupling, add the following % of reading:

	1–10Hz	10–20Hz	20–50Hz	50–100Hz	100–200Hz
Normal Mode (rms, average)	—	—	0.41	0.07	0.015
Low Frequency Mode (rms)	0.1 0.01	0	0	0	

For low frequency mode below 200Hz, specifications apply for sine wave inputs only.

### AC+DC COUPLING

For DC >20% of AC rms voltage, apply the following additional uncertainty, multiplied by the ratio (DC/total rms). Applies to rms and average measurements.

Range	% of Reading	% of Range
200mV, 20V	0.05	0.1
2V, 200V, 750V	0.07	0.01

### AVERAGE ACV MEASUREMENT

Normal mode rms specifications apply from 10% to 100% of range, for 20Hz–1MHz. Add 0.025% of range uncertainty for 50kHz–100kHz, 0.05% of range uncertainty for 100kHz–200kHz, and 0.5% of range uncertainty for 200kHz–1MHz.

### HIGH CREST FACTOR ADDITIONAL ERROR ±(% OF READING)

Applies to rms measurements.

Crest Factor	1–2	2–3	3–4	4–5
Additional Error	0	0.1	0.2	0.4

### ACV PEAK VALUE MEASUREMENT<sup>19</sup> Repetitive Peak Accuracy, ±(% of reading+% of range), 90 Days, 1 Year or 2 Years, T<sub>CAL</sub> ±5°C

Range	20Hz–1kHz <sup>27</sup>	1kHz–10kHz	10kHz–30kHz	30kHz–50kHz	50kHz–100kHz	100kHz–300kHz	300kHz–500kHz	500kHz–750kHz	750kHz–1MHz	Temperature Coefficient ±(% of reading +% of range)/°C Outside T <sub>CAL</sub> ±5°C
200 mV	0.08+0.7	0.09+0.7	0.1 +0.7	0.15+0.7	0.25+0.7	1.0+0.7	2.5+0.7	5.5+0.7	9+0.7	0.002 + 0.03
2 V	0.08+0.3	0.09+0.3	0.1 +0.3	0.15+0.3	0.25+0.3	1.0+0.3	2.5+0.3	5.5+0.3	9+0.3	0.002 + 0.03
20 V	0.1 +0.7	0.11+0.7	0.14+0.7	0.19+0.7	0.25+0.7	1.0+0.7	2.5+0.7	5.5+0.7	9+0.7	0.004 + 0.03
200 V <sup>21</sup>	0.1 +0.3	0.11+0.3	0.14+0.3	0.19+0.3	0.25+0.3	1.0+0.3 <sup>22</sup>	2.5+0.3 <sup>22</sup>	5.5+0.3 <sup>22</sup>	9+0.3 <sup>22</sup>	0.004 + 0.03
750 V <sup>21</sup>	0.12+0.6	0.16+0.6	0.2 +0.6	0.25+0.6 <sup>22</sup>	0.5 +0.6 <sup>22</sup>					0.01 + 0.02
Valid % of Range <sup>28</sup>	10–400%	10–400%	10–400%	10–350%	10–350%	10–250%	10–150%	10–100%	7.5–75%	

**Default Measurement Resolution:** 4 digits.

**Non-Repetitive Peak:** 10% of range per μs typical slew rate for single spikes.

**Peak Width:** Specifications apply for all peaks ≥1μs.

**Peak Measurement Window:** 100ms per reading.

**Maximum Input:** ±1100V peak, 2 x 1028V·Hz (for inputs above 20V).

<sup>26</sup> Subject to peak input voltage specification.

<sup>27</sup> AC peak specifications assume AC + DC coupling for frequencies below 200Hz.

<sup>28</sup> For overrange readings 200–300% of range, add 0.1% of reading uncertainty. For 300–400% of range, add 0.2% of reading uncertainty.

Keithley Instruments, Inc.  
28775 Aurora Road  
Cleveland, Ohio 44139  
1-888-KEITHLEY  
www.keithley.com

#### Settling Characteristics:

**Normal Mode (rms, avg.):** <300ms to 1% of step change  
<450ms to 0.1% of step change  
<500ms to 0.01% of step change

**Low Frequency Mode (rms)** <5s to 0.1% of final value

**Common Mode Rejection:** For 1kΩ imbalance in either lead: >60dB for line frequency ±0.1%.

**Maximum Volt-Hz Product:**  $2 \times 10^7 \text{V} \cdot \text{Hz}$  (for inputs above 20V).

**Autorangeing:** Autoranges up at 105% of range, down at 10% of range.

## OHMS

### TWO-WIRE AND FOUR-WIRE OHMS

Range	Full Scale	Resolution	Current Source <sup>29</sup>	Open Circuit <sup>12</sup>	Maximum HI Lead Resistance <sup>30</sup>	Maximum LO Lead Resistance <sup>30</sup>	Maximum Offset Compensation <sup>31</sup>
20 Ω	21.0000000	100 nΩ	7.2 mA	5 V	50 Ω	10 Ω	±0.2 V
200 Ω	210.0000000	1 μΩ	960 μA	5 V	200 Ω	100 Ω	±0.2 V
2 kΩ	2100.0000000	10 μΩ	960 μA	5 V	200 Ω	150 Ω	-0.2 V to +2 V
20 kΩ	21.0000000	100 μΩ	96 μA	5 V	1.5 kΩ	1.5 kΩ	-0.2 V to +2 V
200 kΩ	210.0000000	1 mΩ	9.6 μA	5 V	1.5 kΩ	1.5 kΩ	
2 MΩ	2.100000000	10 mΩ	1.9 μA	6 V	1.5 kΩ	1.5 kΩ	
20 MΩ <sup>32</sup>	21.0000000	100 mΩ	1.4 μA <sup>33</sup>	14 V			
200 MΩ <sup>32</sup>	210.0000000	1 Ω	1.4 μA <sup>33</sup>	14 V			
1 GΩ <sup>32</sup>	1.050000000	10 Ω	1.4 μA <sup>33</sup>	14 V			

### KEITHLEY FACTORY CALIBRATION UNCERTAINTY

Range	ppm of reading
20 Ω	29.5
200 Ω	7.7
2 kΩ	6.4
20 kΩ	7.8
200 kΩ	7.3
2 MΩ	14.9
20 MΩ	14.9
200 MΩ	14.9
1 GΩ	14.9

Factory calibration uncertainty represents traceability to NIST. This uncertainty is added to relative accuracy specifications to obtain absolute accuracies.

The 20Ω - 2MΩ range uncertainties are equal to the uncertainty of the respective calibration sources.

The 20MΩ, 200MΩ, and 1GΩ range uncertainties are equal to the uncertainty of the 2MΩ calibration source.

### ENHANCED ACCURACY<sup>34</sup> 10PLC, Offset comp. on, DFILT 10

Range	Transfer <sup>5</sup>	24 Hours <sup>35</sup>	Relative Accuracy ± (ppm of reading + ppm of range)			Temperature Coefficient ± (ppm of reading + ppm of range) / °C Outside T <sub>CAL</sub> ±5°C
			90 Days <sup>7</sup>	1 Year <sup>7</sup>	2 Years <sup>7</sup>	
20Ω	2.5 + 3	5 + 4.5	15 + 6	17 + 6	20 + 6	2.5 + 0.7
200Ω	2.5 + 2	5 + 3	15 + 4	17 + 4	20 + 4	2.5 + 0.5
2 kΩ	1.3 + 0.2	2.5 + 0.3	7 + 0.4	9 + 0.4	11 + 0.4	0.8 + 0.05
20 kΩ	1.3 + 0.2	2.5 + 0.3	7 + 0.4	9 + 0.4	11 + 0.4	0.8 + 0.05
200 kΩ	2.5 + 0.4	5.5 + 0.5	29 + 0.8	35 + 0.9	40 + 1	3.5 + 0.18
2 MΩ	5 + 0.2	12 + 0.3	53 + 0.5	65 + 0.5	75 + 0.5	7 + 0.1
20 MΩ <sup>32</sup>	15 + 0.1	50 + 0.2	175 + 0.6	250 + 0.6	300 + 0.6	20 + 0.1
200 MΩ <sup>32</sup>	50 + 0.5	150 + 1	500 + 3	550 + 3	600 + 3	80 + 0.5
1 GΩ <sup>32</sup>	250 + 2.5	750 + 5	2000 + 15	2050 + 15	2100 + 15	400 + 2.5

<sup>29</sup> Current source has an absolute accuracy of ±5%.

<sup>30</sup> Refers to source lead resistance. Sense lead resistance is limited only by noise considerations. For best results, it is suggested that it be limited to 1.5kΩ.

<sup>31</sup> Offset compensation voltage plus source current times measured resistance must be less than source current times resistance range selected.

<sup>32</sup> For 2-wire mode.

<sup>33</sup> Current source is paralleled with a 10MΩ resistance.

<sup>34</sup> Specifications are for 10 power line cycles, 10-reading repeat digital filter, synchronous autozero, autorange off, 4-wire mode, offset compensation on (for 20Ω to 20kΩ ranges), except as noted.

<sup>35</sup> For T<sub>CAL</sub> ±1°C, following 4-hour warm-up. T<sub>CAL</sub> is ambient temperature at calibration (23°C at the factory).

Keithley Instruments, Inc.  
28775 Aurora Road  
Cleveland, Ohio 44139  
1-888-KEITHLEY  
www.keithley.com

**Resistance Uncertainty:** =  $\pm[(\text{ppm of reading}) \times (\text{measured value}) + (\text{ppm of range}) \times (\text{range used})] / 1,000,000$ .

**% Accuracy:** = (ppm accuracy) / 10,000.

**1ppm of Range:** = 20 counts for ranges up to 200M $\Omega$  and 10 counts on 1G $\Omega$  range at 7H digits.

**SPEED AND ACCURACY** 90 Days

**Accuracy<sup>11, 36</sup>**  
 **$\pm(\text{ppm of reading} + \text{ppm of range} + \text{ppm of range rms noise}^{12})$**

RANGE	10PLC DFILT On, 10 Readings	10PLC DFILT Off	1PLC DFILT On, 10 Readings	1PLC DFILT Off	0.1PLC <sup>37</sup> DFILT Off	0.01PLC <sup>37, 13</sup> DFILT Off
20 $\Omega$	15+11+0	15+11+0.5	15+13+0.5	15+13+1	15+16+25	110+200+35
200 $\Omega$	15+8+0	15+8+0.5	17+8+0.5	17+8+1	17+10+15	110+200+35
2 k $\Omega$	7+0.8+0	7+0.8+0.05	8+0.8+0.07	8+0.8+0.2	8+1+2	130+230+5
20 k $\Omega$	7+0.8+0	7+0.8+0.1	8+0.8+0.1	9+0.8+0.2	40+1+2	130+230+5
200 k $\Omega$	29+0.8+0	29+0.8+0.1	31+0.8+0.1	34+0.8+0.2	250+1+2	
2 M $\Omega$	55+0.5+0	53+0.5+0.1	58+0.5+0.1	68+0.5+0.2	750+0.7+2	
20 M $\Omega$ <sup>32</sup>	175+0.6+0	175+0.6+0	175+0.6+0	200+0.6+0		
200 M $\Omega$ <sup>32</sup>	500+3+0	510+3+0	510+3+0	550+3+0		
1 G $\Omega$ <sup>32</sup>	2000+15+0	2100+15+0	2100+15+0	2500+15+0		

PLC = Power Line Cycles. DFILT = Digital Filter.

**2-WIRE ACCURACY**  $\pm(\text{ppm of range})$

Range	Additional Uncertainty (inside T <sub>cal</sub> $\pm$ 5°C)	Temperature Coefficient (outside T <sub>cal</sub> $\pm$ 5°C)
20 $\Omega$	300 ppm	70 ppm/°C
200 $\Omega$	30 ppm	7 ppm/°C
2 k $\Omega$	3 ppm	0.7 ppm/°C

**NORMAL ACCURACY<sup>36</sup>** 1PLC, Offset comp. off, DFILT off

RANGE	Relative Accuracy $\pm$ (ppm of reading + ppm of range)				Temperature Coefficient $\pm$ (ppm of reading + ppm of range)/°C Outside T <sub>cal</sub> $\pm$ 5°C
	24 Hours <sup>35</sup>	90 Days <sup>7</sup>	1 Year <sup>7</sup>	2 Years <sup>7</sup>	
20 $\Omega$	5+12	15+16	17+17	20+19	2.5+2.5
200 $\Omega$	7+8	17+11	19+12	22+13	2.5+1.8
2k $\Omega$	3.5+1.1	8+1.4	10+1.5	12+1.6	0.8+0.18
20k $\Omega$	4.5+1.1	9+1.4	11+1.5	13+1.6	0.8+0.18
200k $\Omega$	11+1.1	34+1.4	40+1.5	45+1.6	3.5+0.18
2M $\Omega$	27+0.9	68+1.1	80+1.1	90+1.1	7+0.1
20M $\Omega$ <sup>32</sup>	75+0.2	200+0.6	275+0.6	325+0.6	20+0.1
200M $\Omega$ <sup>32</sup>	200+1	550+3	600+3	650+3	80+0.5
1G $\Omega$ <sup>32</sup>	1250+5	2500+15	2550+15	2600+15	400+2.5

**Settling Characteristics:** Pre-programmed settling delay times are for <500pF external circuit capacitance. Reading settling times are affected by source impedance and cable dielectric absorption characteristics.

**Ohms Voltage Drop Measurement:** Available as a multiple display.

**Autoranging:** Autoranges up at 105% of range, down at 10% of range.

**2-WIRE RESISTANCE READING RATES<sup>12, 17</sup>**

PLC	Measurement Aperture	Bits	Default Digits	Readings/Second to Memory		Readings/Second to IEEE-488 <sup>18</sup>		Readings/Second with Time Stamp to IEEE-488 <sup>18</sup>	
				Autozero Off	Auto zero On	Autozero Off	Autozero On	Autozero Off	Autozero On
10	167 ms (200 ms)	29	8½	6 (5)	2 (1.7)	6 (5)	2 (1.6)	6 (5)	2 (1.6)
2	33.4 ms (40 ms)	27	7½	29 (25)	9 (7.6)	29 (24)	9 (7.4)	27 (22)	9 (7.4)
1	16.7 ms (20 ms)	26	7½	56 (48)	47 (40)	55 (45)	46 (38)	50 (41)	42 (34)
0.2 <sup>37</sup>	3.34 ms (4 ms)	23	6½	222 (197)	156 (139)	220 (196)	148 (132)	156 (139)	107 (95)
0.1 <sup>37</sup>	1.67 ms (2 ms)	22	6½	330 (317)	176 (169)	305 (293)	166 (159)	157 (151)	110 (106)
0.02 <sup>37</sup>	334 $\mu$ s (400 $\mu$ s)	20	5½	330 (330)	182 (182)	305 (305)	172 (172)	160 (160)	113 (113)
0.01 <sup>37</sup>	167 $\mu$ s (167 $\mu$ s)	19	4½	384 (384)	186 (186)	352 (352)	172 (172)	179 (179)	123 (123)
0.01 <sup>37</sup>	167 $\mu$ s (167 $\mu$ s)	19	4½	2000 (2000)		2000 (2000)			

<sup>36</sup> Specifications are for 1 power line cycle, normal autozero, digital filter off, autorange off, 4-wire mode, offset compensation off, except as noted.

<sup>37</sup> Ohms measurements at rates lower than 1 power line cycle are subject to potential noise pickup. Care must be taken to provide adequate shielding.

Keithley Instruments, Inc.  
28775 Aurora Road  
Cleveland, Ohio 44139  
1-888-KEITHLEY  
www.keithley.com

#### 4-WIRE RESISTANCE READING RATES<sup>12</sup>, Error! Bookmark not defined.

PLC	Measurement Aperture	Bits	Default Digits	Readings or Readings with Time Stamp/Second to Memory or IEEE-488 <sup>18</sup>			
				Autozero Off Offset Comp. Off	Autozero Off Offset Comp. On	Autozero On Offset Comp. Off	Autozero On Offset Comp. On
10	167 ms (200 ms)	29	8½	6 (5)	3 (2.5)	2 (1.6)	1 (0.8)
2	33.4 ms (40 ms)	27	7½	27 (22)	13 (10.7)	9 (7.4)	4 (3.5)
1	16.7 ms (20 ms)	26	7½	50 (41)	25 (20)	42 (34)	20 (16)
0.2 <sup>37</sup>	3.34 ms (4 ms)	23	6½	154 (137)	76 (68)	115 (102)	54 (48)
0.1 <sup>37</sup>	1.67 ms (2 ms)	22	6½	184 (176)	92 (88)	123 (118)	63 (60)
0.02 <sup>37</sup>	334 µs (400 µs)	20	5½	186 (186)	107 (107)	126 (126)	72 (72)
0.01 <sup>37</sup>	167 µs (167 µs)	19	4½	211 (211)	107 (107)	133 (133)	72 (72)

## DC AMPS

### DCI INPUT CHARACTERISTICS AND ACCURACY

Range	Full Scale	Resolution	Maximum Burden Voltage <sup>38</sup>	Relative Accuracy <sup>39</sup> Temperature Coefficient <sup>39</sup>				
				±(ppm of reading + ppm of range)		±(ppm of reading + ppm of range)/°C		
				24 Hours <sup>40</sup>	90 Days <sup>41</sup>	1 Year <sup>41</sup>	2 Years <sup>41</sup>	Outside T <sub>CAL</sub> ±5°C
200 µA	210.00000	10 pA	0.25 V	50 + 6	275 + 25	350 + 25	500 + 25	50 + 5
2 mA	2.1000000	100 pA	0.3 V	50 + 5	275 + 20	350 + 20	500 + 20	50 + 5
20 mA	21.000000	1 nA	0.35 V	50 + 5	275 + 20	350 + 20	500 + 20	50 + 5
200 mA	210.00000	10 nA	0.35 V	75 + 5	300 + 20	375 + 20	525 + 20	50 + 5
2 A	2.1000000	100 nA	1.1 V	350 + 5	600 + 20	750 + 20	1000 + 20	50 + 5

DC Current Uncertainty: = ± [ (ppm reading) x (measured value) + (ppm of range) x (range used) ] / 1,000,000.

% Accuracy: = (ppm accuracy) / 10,000.

5ppm of Range: = 10 counts at 6½ digits.

### DCI READING RATES<sup>12, 17</sup>

PLC	Measurement Aperture	Bits	Default Digits	Readings/Second to Memory		Readings/Second to IEEE-488 <sup>18</sup>		Readings/Second with Time Stamp to IEEE-488 <sup>18</sup>	
				Autozero Off	Autozero On	Autozero Off	Autozero On	Autozero Off	Autozero On
10	167 ms (200 ms)	29	7½	6 (5)	2 (1.7)	6 (5)	2 (1.6)	6 (5)	2 (1.6)
2	33.4 ms (40 ms)	27	7½	29 (25)	9 (7.6)	29 (24)	9 (7.4)	27 (22)	9 (7.4)
1	16.7 ms (20 ms)	26	6½	56 (48)	47 (40)	55 (45)	46 (38)	50 (41)	42 (34)
0.2	3.34 ms (4 ms)	23	6½	222 (197)	157 (140)	209 (186)	150 (133)	156 (139)	113 (100)
0.1	1.67 ms (2 ms)	22	5½	334 (321)	178 (171)	310 (298)	168 (161)	186 (178)	124 (119)
0.02	334 µs (400 µs)	20	5½	334 (334)	184 (184)	310 (310)	174 (174)	187 (187)	127 (127)
0.01	167 µs (167 µs)	19	4½	387 (387)	186 (186)	355 (355)	176 (176)	202 (202)	128 (128)
0.01 <sup>3</sup>	167 µs (167 µs)	19	4½	2000 (2000)		2000 (2000)			

### SPEED AND ACCURACY 90 Days

Range	ACCURACY <sup>39, 11</sup>			
	±(ppm of reading + ppm of range + ppm of range rms noise <sup>12</sup> )			
	1PLC DFILT On, 10 Readings	1PLC DFILT Off	0.1PLC DFILT Off	0.01PLC <sup>13</sup> DFILT Off
200µA	275+25+0	275+25+0.5	300+25+50	300+200+80
2 mA	275+20+0	275+20+0.5	300+20+50	300+200+80
20 mA	275+20+0	275+20+0.5	300+20+50	300+200+80
200 mA	300+20+0	300+20+0.5	325+20+50	325+200+80
2 A	600+20+0	600+20+0.5	625+20+50	625+200+80

PLC = Power Line Cycles. DFILT = Digital Filter.

### KEITHLEY FACTORY CALIBRATION UNCERTAINTY

Range	ppm of reading
200 µA	43
2 mA	40
20 mA	55
200 mA	162
2 A	129

<sup>38</sup> Actual maximum burden voltage = (maximum burden voltage) x (I MEASURED/I FULL SCALE).

<sup>39</sup> Specifications are for 1 power line cycle, autozero on, 10-reading repeat digital filter.

<sup>40</sup> For T<sub>CAL</sub> ± 1°C, following 55-minute warm-up. T<sub>CAL</sub> is ambient temperature at calibration (23°C at the factory).

<sup>41</sup> For T<sub>CAL</sub> ± 5°C, following 55-minute warm-up.



Keithley Instruments, Inc.  
28775 Aurora Road  
Cleveland, Ohio 44139  
1-888-KEITHLEY  
www.keithley.com

Factory calibration uncertainty represents traceability to NIST. This uncertainty is added to relative accuracy specifications to obtain absolute accuracies. The uncertainties for each range are equal to the uncertainty of the respective calibration sources.

**Settling Characteristics:** <500 $\mu$ s to 50ppm of step size. Reading settling times are affected by source impedance and cable dielectric absorption characteristics.

**Maximum Allowable Input:** 2.1A, 250V.

**Overload Protection:** 2A fuse (250V), accessible from front (for front input) and rear (for rear input).

**Autoranging:** Autoranges up at 105% of range, down at 10% of range.

## DC IN-CIRCUIT CURRENT

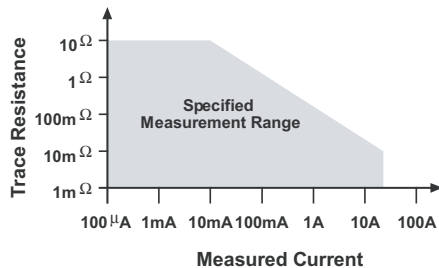

The DC in-circuit current measurement function allows a user to measure the current through a wire or a circuit board trace without breaking the circuit.

When the In-Circuit Current Measurement function is selected, the 2002 will first perform a 4-wire resistance measurement, then a voltage measurement, and will display the calculated current.

### TYPICAL RANGES

**Current:** 100 $\mu$ A to 12A.

**Trace Resistance:** 1m $\Omega$  to 10 $\Omega$ .

**Voltage:**  $\pm$ 200mV max. across trace.

**Speed:** 4 measurements/second at 1 power line cycle.

**Accuracy:**  $\pm$ (5% + 500 $\mu$ A). For 1 power line cycle, autozero on, 10-reading digital filter, T<sub>CAL</sub>  $\pm$ 5 $^{\circ}$ C, 90 days, 1 year or 2 years.

## AC AMPS

### ACI INPUT CHARACTERISTICS

rms Range	Peak Input	Full Scale rms	Resolution	Maximum Burden Voltage <sup>38</sup>	Temperature Coefficient $\pm$ (% of reading + % of range) <sup>19</sup> C Outside T <sub>CAL</sub> $\pm$ 5 $^{\circ}$ C
200 $\mu$ A	1 mA	210.0000	100 $\mu$ A	0.35 V	0.01 + 0.001
2 mA	10 mA	2.100000	1 nA	0.45 V	0.01 + 0.001
20 mA	100 mA	21.000000	10 nA	0.5 V	0.01 + 0.001
200 mA	1 A	210.00000	100 nA	0.5 V	0.01 + 0.001
2 A	2 A	2.1000000	1 $\mu$ A	1.5 V	0.01 + 0.001

**ACI ACCURACY<sup>24, 42</sup>** 90 Days, 1 Year or 2 Years, T<sub>CAL</sub>  $\pm$ 5 $^{\circ}$ C, for 5% to 100% of range,  $\pm$ (% of reading + % of range)

Range	20Hz–50Hz	50Hz–200Hz	200Hz–1kHz	1kHz–10kHz	10kHz–30kHz <sup>22</sup>	30kHz–50kHz <sup>22</sup>	50kHz–100kHz <sup>22</sup>
200 $\mu$ A	0.35 + 0.015	0.2 + 0.015	0.4 + 0.015	0.5 + 0.015			
2 mA	0.3 + 0.015	0.15 + 0.015	0.12 + 0.015	0.12 + 0.015	0.25 + 0.015	0.3 + 0.015	0.5 + 0.015
20 mA	0.3 + 0.015	0.15 + 0.015	0.12 + 0.015	0.12 + 0.015	0.25 + 0.015	0.3 + 0.015	0.5 + 0.015
200 mA	0.3 + 0.015	0.15 + 0.015	0.12 + 0.015	0.15 + 0.015	0.5 + 0.015	1 + 0.015	3 + 0.015
2 A	0.35 + 0.015	0.2 + 0.015	0.3 + 0.015	0.45 + 0.015	1.5 + 0.015	4 + 0.015	

**AC Current Uncertainty:** =  $\pm$ [ (% of reading) x (measured value) + (% of range) x (range used) ] / 100.

**ppm Accuracy:** = (% accuracy) x 10,000.

**0.015% of Range:** = 30 counts at 5H digits.

### ACI READING RATES<sup>17, 22</sup>

PLC	Measurement Aperture	Bits	Default Digits	Readings/Second to Memory		Readings/Second to IEEE-488 <sup>18</sup>		Readings/Second with Time Stamp to IEEE-488 <sup>18</sup>	
				Autozero Off	Autozero On	Autozero Off	Autozero On	Autozero Off	Autozero On
10	167 ms (200 ms)	29	6½	6 (5)	2 (1.7)	6 (5)	2 (1.6)	6 (5)	2 (1.6)
2	33.4 ms (40 ms)	27	5½	29 (25)	9 (7.6)	28 (23)	9 (7.4)	27 (22)	9 (7.4)
1	16.7 ms (20 ms)	26	5½	56 (48)	47 (40)	53 (43)	44 (36)	47 (38)	40 (33)
0.2	3.34 ms (4 ms)	23	5½	163 (145)	102 (91)	139 (124)	100 (89)	95 (84)	74 (66)
0.1	1.67 ms (2 ms)	22	5½	163 (156)	104 (100)	139 (133)	101 (97)	95 (91)	75 (72)
0.02	334 $\mu$ s (400 $\mu$ s)	20	5½	163 (163)	107 (107)	139 (139)	103 (103)	95 (95)	76 (76)
0.01	167 $\mu$ s (167 $\mu$ s)	19	4½	384 (384)	110 (110)	253 (253)	103 (103)	164 (164)	76 (76)
0.01 <sup>15</sup>	167 $\mu$ s (167 $\mu$ s)	19	4½	2000 (2000)		2000 (2000)			

<sup>42</sup> Add 0.005% of range uncertainty for current above 0.5A rms for self-heating.

Keithley Instruments, Inc.  
28775 Aurora Road  
Cleveland, Ohio 44139  
1-888-KEITHLEY  
www.keithley.com

### AC COUPLING

For AC only coupling, add the following % of reading:

	20–50Hz	50–100Hz	100–200Hz
rms, Average	0.55	0.09	0.015

### AC+DC COUPLING

For DC>20% of AC rms voltage, apply the following additional uncertainty, multiplied by the ratio (DC/total rms).

	% of Reading	% of Range
rms, Average	0.05	0.1

### HIGH CREST FACTOR ADDITIONAL ERROR ±(% of reading)

Applies to rms measurements.

Crest Factor	1 – 2	2 – 3	3 – 4	4 – 5
Additional Error	0	0.1	0.2	0.4

### AVERAGE ACI MEASUREMENT

rms specifications apply for 10% to 100% of range.

**Settling Characteristics:** <300ms to 1% of step change  
<450ms to 0.1% of step change  
<500ms to 0.01% of step change

**Autorangeing:** Autoranges up at 105% of range, down at 10% of range.

## FREQUENCY COUNTER

### FREQUENCY/PERIOD INPUT CHARACTERISTICS AND ACCURACY 90 Days, 1 Year, or 2 Years

	Frequency Range <sup>43</sup>	Period Range	Resolution	Minimum Signal Level <sup>44</sup>			Maximum Input	Trigger Level	Accuracy ±(% of reading)
				1Hz–1MHz	1–5MHz	5–15MHz			
AC Voltage Input	1Hz–15 MHz	67 ns – 1 s	5 digits	60 mV	60 mV	400 mV	1100 V pk <sup>45</sup>	0–600V	0.03
AC Current Input	1Hz–1 MHz	1 μs – 1 s	5 digits	150 μA			1 A pk	0–600mA	0.03

**Time Base:** 7.68MHz ± 0.01%, 0°C to 55°C.

**Reading Time:** 420ms maximum.

**Voltage Input Impedance:** 1MΩ ± 2% with <140pF.

**Trigger Level Adjustment:** Trigger level is adjustable in 0.5% of range steps to ±60% of range in real-time using the up and down range buttons.

**Frequency Ranging:** Autoranging from Hz to MHz.

**Frequency Coupling:** AC only.

## TEMPERATURE (RTD)

Range	Resolution	4-Wire Accuracy <sup>45</sup>			
		24 Hours <sup>46</sup>	90 Days <sup>7</sup>	1 Year <sup>7</sup>	2 Years <sup>7</sup>
–100° to +100°C	0.001°C	±0.016°C	±0.020°C	±0.021°C	±0.022°C
–200° to +630°C	0.001°C	±0.061°C	±0.066°C	±0.068°C	±0.070°C
–148° to +212°F	0.001°F	±0.029°F	±0.036°F	±0.038°F	±0.040°F
–328° to +1166°F	0.001°F	±0.110°F	±0.119°F	±0.122°F	±0.126°F

**RTD Type:** 100Ω platinum, DIN 43760, 4-wire. ITS-90 (PT100, D100, F100) and IPTS-68 (PT385, PT3916).

**Sensor Current:** 960μA (pulsed).

**Temperature Coefficient:** ±0.001°C/°C or ±0.002°F/°C outside T<sub>CAL</sub> ±5°C.

**Maximum Source HI Lead Resistance:** 200Ω.

**Maximum Source LO Lead Resistance:** 100Ω.

<sup>43</sup> Subject to 2 × 10<sup>7</sup>V·Hz product (for inputs above 20V).

<sup>44</sup> Valid for the lowest range. For each range increase, multiply these numbers by 10.

<sup>45</sup> Specifications are for 10 power line cycles, autozero on, 10 reading repeat digital filter, 4-wire mode. Exclusive of RTD probe errors.

<sup>46</sup> For T<sub>CAL</sub> ± 1°C, following 4-hour warm-up.

Keithley Instruments, Inc.  
28775 Aurora Road  
Cleveland, Ohio 44139  
1-888-KEITHLEY  
www.keithley.com

## RTD TEMPERATURE READING RATES<sup>17</sup> (2- or 4-Wire)

PLC	Autozero Off	Readings or Readings with Time Stamp/Second to Memory or IEEE-488
	Autozero On	
10	3 (2.5)	1 (0.8)
2	12 (10)	4 (3.3)
1	20 (16)	17 (13)
0.1	51 (49)	41 (39)
0.01	58 (58)	46 (46)

## TEMPERATURE (THERMOCOUPLE)

Thermocouple Type	Range	Resolution	Accuracy <sup>17</sup>
J	-200° to +760°C	0.001°C	±0.5°C
K	-200° to +1372°C	0.001°C	±0.5°C
T	-200° to +400°C	0.001°C	±0.5°C
E	-200° to +1000°C	0.001°C	±0.6°C
R	0° to +1768°C	0.001°C	±3 °C
S	0° to +1768°C	0.001°C	±3 °C
B	+350° to +1820°C	0.001°C	±5 °C

## TC Temperature Reading Rates Error! Bookmark not defined.

PLC	Readings/Second to Memory Autozero		Readings/Second to IEEE-488 <sup>18</sup> Autozero		Readings/Second with Time Stamp to IEEE-488 <sup>18</sup> Autozero	
	Off	On	Off	On	Off	On
10	6 (5)	2 (1.7)	6 (5)	2 (1.6)	6 (5)	2 (1.6)
2	29 (25)	9 (7.6)	29 (24)	9 (7.4)	27 (22)	9 (7.4)
1	57 (48)	47 (40)	56 (46)	46 (38)	50 (41)	42 (34)
0.1	131 (126)	107 (103)	100 (96)	84 (81)	83 (80)	72 (69)
0.01	168 (168)	112 (112)	121 (121)	89 (89)	96 (96)	74 (74)

## OPERATING SPEED

### FUNCTION CHANGE SPEED<sup>48</sup>

Typical delay before measurement initiation after making a function change.

From Function	To Function	Range	Time
Any except 4WΩ, Temp	DCV	Any	4.6 ms
4WΩ, Temp		Any	7.6 ms
Any	ACV	Any	574 ms
ACV, DCV, 2WΩ, Freq	DCI	Any	7.1 ms
4WΩ, Temp		Any	10 ms
ACI		Any	22 ms
Any	ACI	Any	523 ms
Any except 4WΩ, Temp	2WΩ	20Ω to 2kΩ	4.7 ms
		20kΩ	15 ms
		200kΩ	27 ms
		2MΩ	103 ms
		20MΩ	153 ms
		200MΩ, 1GΩ	253 ms
4WΩ, Temp	2WΩ	20Ω to 2kΩ	7.7 ms
		20kΩ	18 ms
		200kΩ	30 ms
		2MΩ	105 ms
		20MΩ	157 ms
		200MΩ, 1GΩ	256 ms
Any	4WΩ	20Ω to 2kΩ	7.7 ms
		20kΩ	18 ms

<sup>47</sup> Relative to external 0°C reference junction; exclusive of thermocouple errors. Junction temperature may be external. Applies for 90 days, 1 year or 2 years, T<sub>cal</sub> ±5°C.

<sup>48</sup> For display off, 0.01 power line cycles, autorange off, digital filter off, autozero on, offset compensation off. Display on may impact time by 3% worst case. To eliminate this impact, press ENTER (hold) to freeze display.

Keithley Instruments, Inc.  
28775 Aurora Road  
Cleveland, Ohio 44139  
1-888-KEITHLEY  
www.keithley.com

		200k $\Omega$	30 ms
		2M $\Omega$	105 ms
Any except ACV, ACI	Freq <sup>49</sup>	Any	60 ms
ACV, ACI		Any	573 ms
Any	Temp	Any	7.6 ms

#### RANGE CHANGE SPEED<sup>48</sup>

Typical delay before measurement initiation after making a range change.

Function	From	To	Time
DCV	Any	Any	5.2 ms
ACV	Any	Any	559 ms
DCI	Any	Any	7.6 ms
ACI	Any	Any	503 ms
2W $\Omega$	Any	20 $\Omega$ to 2k $\Omega$	5.2 ms
	Any	20k $\Omega$	15 ms
	Any	200k $\Omega$	27 ms
	Any	2M $\Omega$	103 ms
	Any	20M $\Omega$	153 ms
	Any	200M $\Omega$ , 1G $\Omega$	253 ms
4W $\Omega$	Any	20 $\Omega$ to 2k $\Omega$	5.2 ms
	Any	20k $\Omega$	15 ms
	Any	200k $\Omega$	27 ms
	Any	2M $\Omega$	103 ms

#### TRIGGER SPEED (EXTERNAL TRIGGER OR TRIGGER-LINK)

	Autozero Off	Autozero On
Trigger Latency:	< 2 $\mu$ s	1.2 ms typical
Trigger Jitter:	$\pm$ 0.5 $\mu$ s	

#### GPIB DATA FORMATTING TRANSMISSION TIME<sup>50</sup>

Format	Readings Only		Readings with Time Stamp	
	Time	Rdg./s	Time	Rdg./s
DREAL (Double precision real)	0.51 ms	1961	3.1 ms	323
SREAL (Single precision real)	0.38 ms	2632	3.3 ms	303
ASCII	6.2 ms	161	10.2 ms	98

#### SINGLE FUNCTION SCAN SPEED<sup>51</sup> (INTERNAL SCANNER)

TYPE	DCV (20V)		2W $\Omega$ (2k $\Omega$ )		4W $\Omega$ (2k $\Omega$ )		ACV		Freq		TC Temp		RTD Temp (2-Wire)	
	Time per Chan.	Rate (Chan./second)	Time per Chan.	Rate (Chan./second)	Time per Chan.	Rate (Chan./second)	Time per Chan.	Rate (Chan./second)	Time per Chan.	Rate (Chan./second)	Time per Chan.	Rate (Chan./second)	Time per Chan.	Rate (Chan./second)
Ratio or Delta <sup>52</sup> (2 channels)	8.2 ms	122	8.5 ms	118	18.8 ms	53								
Fast Scan (using solid state channels)	8.2 ms	122	6.3 ms	159			501 ms	2	559 ms	1.8	12.8 ms	78		
Normal Scan	14 ms	71	11.4 ms	88	14.4 ms	69	506 ms	2	564 ms	1.8	17.2 ms	58	43 ms	23

<sup>49</sup> Based on 100kHz input frequency.

<sup>50</sup> Using 386/33 computer, average time for 1000 readings, byte order swapped, display off.

<sup>51</sup> For on-scale readings, no trigger delays, display off, 0.01 power line cycles, autorange off, digital filter off, offset compensation off, autozero off.

<sup>52</sup> Ratio and delta functions output one value for each pair of measurements.

Keithley Instruments, Inc.  
28775 Aurora Road  
Cleveland, Ohio 44139  
1-888-KEITHLEY  
www.keithley.com

**MAXIMUM INPUT LEVELS**

	Rated Input <sup>53</sup>	Overload Recovery Time
HI to LO	±1100V	< 900 ms
HI Sense to LO	± 350V pk 250V rms	< 900 ms
LO Sense to LO	± 150V pk 100V rms	< 900 ms
I Input to LO	2A, ± 250V (fused)	—
HI to Earth	±1600V	< 900 ms
LO to Earth	± 500V	

**DELAY AND TIMER**

**Time Stamp**     **Resolution:** 1µs.  
**Accuracy:** ±0.01% of elapsed time ± 1µs.  
**Maximum:** 2,100,000.000000 seconds (24 days, 7 hours).

**Delay Time**     **(Trigger edge to reading initiation)**  
**Maximum:** 999,999.999 seconds (11 days, 14 hours).  
**Resolution:** 1ms.  
**Jitter:** ±1ms.

**Timer**            **(Reading initiation to reading initiation)**  
**Maximum:** 999,999.999 seconds (11 days, 14 hours).  
**Resolution:** 1ms.  
**Jitter:** ±1ms.

**IEEE-488 BUS IMPLEMENTATION**

**Implementation:** IEEE-488.2, SCPI-1991.0.

**Multiline Commands:** DCL, LLO, SDC, GET, GTL, UNT, UNL, SPE, SPD.

**Uniline Commands:** IFC, REN, EOI, SRQ, ATN.

**Interface Commands:** SH1, AH1, T5, TE0, L4, LE0, SR1, RL1, PP0, DC1, DT1, C0, E1.

**DIGITAL I/O**

**Connector Type:** 8 pin "D" subminiature.

**Input:** One pin, TTL compatible.

**Outputs:** Four pins. Open collector, 30V maximum pull-up voltage, 100mA maximum sink current, 10Ω output impedance.

**Control:** Direct control by output or set real-time with limits.

**GENERAL SPECIFICATIONS AND STANDARDS COMPLIANCE**

**Power**            **Voltage:** 90–134V and 180–250V, universal self-selecting.  
**Frequency:** 50Hz, 60Hz, or 400Hz, self-identifying at power-up.  
**Consumption:** <55VA.

**Environmental**     **Operating Temperature:** 0°C to 50°C.  
**Storage Temperature:** –40°C to 70°C.  
**Humidity:** 80% R.H., 0°C to 35°C, per MIL-T-28800E<sup>54</sup> Para 4.5.5.1.2.

**Calibration**        **Type:** Software. No manual adjustments required.  
**Sources:** 2 DC voltages, 6 resistances, and 5 DC currents. All other functions calibrated (adjusted) from these sources and a short circuit. No AC calibrator required for adjustment.  
**Average Time to Perform:** 40 minutes for comprehensive calibration, 6 minutes for AC-only calibration.  
**Process:** MIL-STD 45662A.

<sup>53</sup> For voltages between other terminals, these ratings can be added.

<sup>54</sup> For MIL-T-28800E, applies to Type III, Class 5, Style E.

**Keithley Instruments, Inc.**  
 28775 Aurora Road  
 Cleveland, Ohio 44139  
 1-888-KEITHLEY  
 www.keithley.com

- Physical**            **Case Dimensions:** 90mm high × 214mm wide × 369mm deep (3½ in. × 8½ in. × 14½ in.).  
**Working Dimensions:** From front of case to rear including power cord and IEEE-488 connector: 15.0 inches.  
**Net Weight:** <4.2kg (<9.2 lbs.).  
**Shipping Weight:** <9.1kg (<20 lbs.).
- Standards**        **EMI/RFI:** Conforms to VDE 0871B (per Vfg 1046/1984), IEC 801-2. Meets FCC part 15 Class B, CISPR-22 (EN55022).  
**Safety:** Conforms to IEC348, CAN/CSA-C22.2. No. 231, MIL-T-28800E<sup>1</sup>. Designed to UL1244.
- Accessories Supplied**    The unit is shipped with line cord, high performance modular test leads, operator's manual, option slot cover, and full calibration data.

## EXTENDED MEMORY/NON-VOLATILE MEMORY OPTIONS

### DATA STORAGE

Model	Size (Bytes)	4½-Digit	6½-Digit with Time Stamp	Type	Setup Storage	
					Number	Type
2002	8k	2,027	404	volatile	1	non-volatile
2002/MEM1	32k	6,909	1,381	non-volatile	5	non-volatile
2002/MEM2	128k	29,908	5,980	non-volatile	10	non-volatile

These are the minimum sizes to expect.

# B

## Interface Function Codes

---

The interface function codes, which are part of the IEEE-488 standards, define an instrument's ability to support various interface functions and should not be confused with programming commands found elsewhere in this manual. The interface function codes for the Model 2002 are listed in Table B-1. The codes define Model 2002 capabilities as follows:

**Table B-1**

*Model 2002 interface function codes*

Code	Interface function
SH1	Source Handshake capability
AH1	Acceptor Handshake capability
T5	Talker (basic talker, talk-only, serial poll, unaddressed to talk on LAG)
L4	Listener (basic listener, unaddressed to listen on TAG)
SR1	Service Request capability
RL1	Remote/Local capability
PP0	No Parallel Poll capability
DC1	Device Clear capability
DT1	Device Trigger capability
C0	No Controller capability
E1	Open collector bus drivers
TE0	No Extended Talker capability
LE0	No Extended Listener capability

**SH (Source Handshake Function)** — SH1 defines the ability of the instrument to initiate the transfer of message/data over the data bus.

**AH (Acceptor Handshake Function)** — AH1 defines the ability of the instrument to guarantee proper reception of message/data transmitted over the data bus.

**T (Talker Function)** — The ability of the instrument to send data over the bus to other devices is provided by the T function. Instrument talker capabilities (T5) exist only after the instrument has been addressed to talk.

**L (Listener Function)** — The ability for the instrument to receive device-dependent data over the bus from other devices is provided by the L function. Listener capabilities (L4) of the instrument exist only after it has been addressed to listen.

**SR (Service Request Function)** — SR1 defines the ability of the instrument to request service from the controller.

**RL (Remote-Local Function)** — RL1 defines the ability of the instrument to be placed in the remote or local modes.

**PP (Parallel Poll Function)** — The instrument does not have parallel polling capabilities (PP0).

**DC (Device Clear Function)** — DC1 defines the ability of the instrument to be cleared (initialized).

**DT (Device Trigger Function)** — DT1 defines the ability of the Model 2002 to have readings triggered.

**C (Controller Function)** — The instrument does not have controller capabilities (C0).

**TE (Extended Talker Function)** — The instrument does not have extended talker capabilities (TE0).

**LE (Extended Listener Function)** — The instrument does not have extended listener capabilities (LE0).

**E (Bus Driver Type)** — The instrument has open-collector bus drivers (E1).

# C

## ASCII Character Codes and IEEE-488 Multiline Interface Command Messages

---

Decimal	Hexadecimal	ASCII	IEEE-488 Messages*
0	00	NUL	
1	01	SOH	GTL
2	02	STX	
3	03	ETX	
4	04	EOT	SDC
5	05	ENQ	PPC
6	06	ACK	
7	07	BEL	
8	08	BS	GET
9	09	HT	TCT
10	0A	LF	
11	0B	VT	
12	0C	FF	
13	0D	CR	
14	0E	SO	
15	0F	SI	

Decimal	Hexadecimal	ASCII	IEEE-488 Messages*
16	10	DLE	
17	11	DC1	LLO
18	12	DC2	
19	13	DC3	
20	14	DC4	DCL
21	15	NAK	PPU
22	16	SYN	
23	17	ETB	
24	18	CAN	SPE
25	19	EM	SPD
26	1A	SUB	
27	1B	ESC	
28	1C	FS	
29	1D	GS	
30	1E	RS	
31	1F	US	

\* Message sent or received with ATN true.



Decimal	Hexadecimal	ASCII	IEEE-488 Messages*
32	20	SP	MLA 0
33	21	!	MLA 1
34	22	"	MLA 2
35	23	#	MLA 3
36	24	\$	MLA 4
37	25	%	MLA 5
38	26	&	MLA 6
39	27	'	MLA 7
40	28	(	MLA 8
41	29	)	MLA 9
42	2A	*	MLA 10
43	2B	+	MLA 11
44	2C	,	MLA 12
45	2D	-	MLA 13
46	2E	.	MLA 14
47	2F	/	MLA 15
48	30	0	MLA 16
49	31	1	MLA 17
50	32	2	MLA 18
51	33	3	MLA 19
52	34	4	MLA 20
53	35	5	MLA 21
54	36	6	MLA 22
55	37	7	MLA 23
56	38	8	MLA 24
57	39	9	MLA 25
58	3A	:	MLA 26
59	3B	;	MLA 27
60	3C	<	MLA 28
61	3D	=	MLA 29
62	3E	>	MLA 30
63	3F	?	UNL

\* Message sent or received with ATN true. Numbers shown represent primary address resulting in MLA (My Listen Address).

Decimal	Hexadecimal	ASCII	IEEE-488 Messages*
64	40	@	MTA 0
65	41	A	MTA 1
66	42	B	MTA 2
67	43	C	MTA 3
68	44	D	MTA 4
69	45	E	MTA 5
70	46	F	MTA 6
71	47	G	MTA 7
72	48	H	MTA 8
73	49	I	MTA 9
74	4A	J	MTA 10
75	4B	K	MTA 11
76	4C	L	MTA 12
77	4D	M	MTA 13
78	4E	N	MTA 14
79	4F	O	MTA 15
80	50	P	MTA 16
81	51	Q	MTA 17
82	52	R	MTA 18
83	53	S	MTA 19
84	54	T	MTA 20
85	55	U	MTA 21
86	56	V	MTA 22
87	57	W	MTA 23
88	58	X	MTA 24
89	59	Y	MTA 25
90	5A	Z	MTA 26
91	5B	[	MTA 27
92	5C	\	MTA 28
93	5D	]	MTA 29
94	5E	«	MTA 30
95	5F	æ	UNL

\* Message sent or received with ATN true. Numbers shown are primary address resulting in MTA (My Talk Address).

Decimal	Hexadecimal	ASCII	IEEE-488 Messages*
96	60	«	MSA 0, PPE
97	61	a	MSA 1, PPE
98	62	b	MSA 2, PPE
99	63	c	MSA 3, PPE
100	64	d	MSA 4, PPE
101	65	e	MSA 5, PPE
102	66	f	MSA6, PPE
103	67	g	MSA 7, PPE
104	68	h	MSA 8, PPE
105	69	i	MSA 9, PPE
106	6A	j	MSA 10, PPE
107	6B	k	MSA 11, PPE
108	6C	l	MSA 12, PPE
109	6D	m	MSA 13, PPE
110	6E	n	MSA 14, PPE
111	6F	o	MSA 15, PPE

Decimal	Hexadecimal	ASCII	IEEE-488 Messages*
112	70	p	MSA 16, PPD
113	71	q	MSA 17, PPD
114	72	r	MSA 18, PPD
115	73	s	MSA 19, PPD
116	74	t	MSA 20, PPD
117	75	u	MSA 21, PPD
118	76	v	MSA 22, PPD
119	77	w	MSA 23, PPD
120	78	x	MSA 24, PPD
121	79	y	MSA 25, PPD
122	7A	z	MSA 26, PPD
123	7B	{	MSA 27, PPD
124	7C		MSA 28, PPD
125	7D	}	MSA 29, PPD
126	7E	~	MSA 30, PPD
127	7F	DEL	

\* Message sent or received with ATN true. Numbers represent secondary address resulting in MSA (My Secondary Address).

# D

## IEEE-488 Bus Overview

---

### Introduction

Basically, the IEEE-488 bus is simply a communication system between two or more electronic devices. A device can be either an instrument or a computer. When a computer is used on the bus, it serves to supervise the communication exchange between all the devices and is known as the controller. Supervision by the controller consists of determining which device will talk and which device will listen. As a talker, a device will output information and as a listener, a device will receive information. To simplify the task of keeping track of the devices, a unique address number is assigned to each one.

On the bus, only one device can talk at a time and is addressed to talk by the controller. The device that is talking is known as the active talker. The devices that need to listen to the talker are addressed to listen by the controller. Each listener is then referred to as an active listener. Devices that do not need to listen are instructed to unlisten. The reason for the unlisten instruction is to optimize the speed of bus information transfer since the task of listening takes up bus time.

Through the use of control lines, a handshake sequence takes place in the transfer process of information from a talker to a listener. This handshake sequence helps ensure the credibility of the information transfer. The basic handshake sequence between an active controller (talker) and a listener is as follows:

1. The listener indicates that it is ready to listen.
2. The talker places the byte of data on the bus and indicates that the data is available to the listener.
3. The listener, aware that the data is available, accepts the data and then indicates that the data has been accepted.

4. The talker, aware that the data has been accepted, stops sending data and indicates that data is not being sent.
5. The listener, aware that there is no data on the bus, indicates that it is ready for the next byte of data.

### Bus description

The IEEE-488 bus, which is also frequently referred to as the GPIB (General Purpose Interface Bus), was designed as a parallel transfer medium to optimize data transfer without using an excessive number of bus lines. In keeping with this goal, the bus has only eight data lines that are used for both data and with most commands. Five bus management lines and three handshake lines round out the complement of bus signal lines.

A typical set up for controlled operation is shown in Figure D-1. Generally, a system will contain one controller and a number of other instruments to which the commands are given. Device operation is categorized into three operators: controller, talker and listener. The controller does what its name implies; it controls the instruments on the bus. The talker sends data while a listener receives data. Depending on the type of instrument, any particular device can be a talker only, a listener only or both a talker and listener.

There are two categories of controllers: system controller, and basic controller. Both are able to control other instruments, but only the system controller has the absolute authority in the system. In a system with more than one controller, only one controller may be active at any given time. Certain protocol is used to pass control from one controller to another.

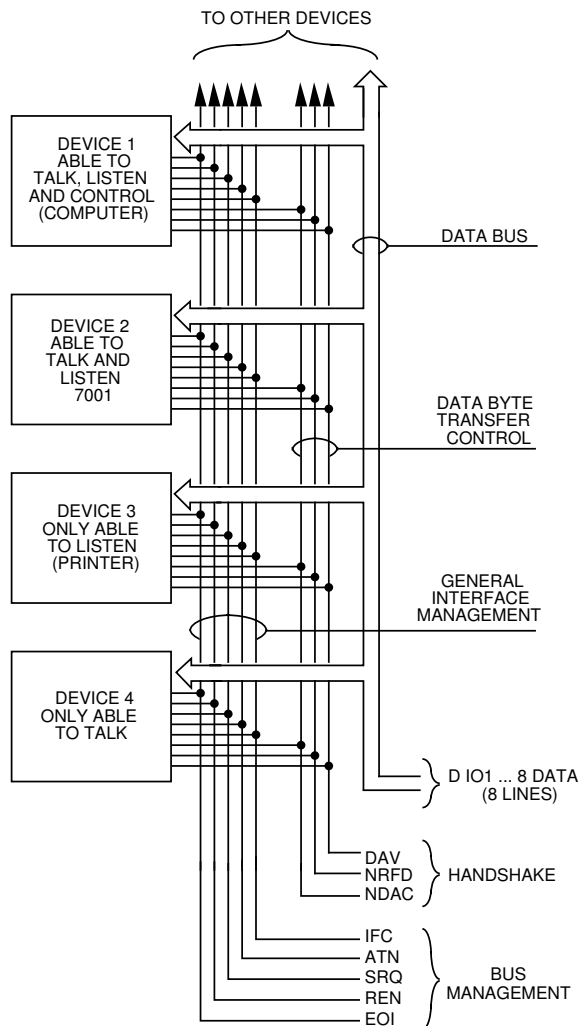

**Figure D-1**  
IEEE-488 bus configuration

The IEEE-488 bus is limited to 15 devices, including the controller. Thus, any number of talkers and listeners up to that limit may be present on the bus at one time. Although several devices may be commanded to listen simultaneously, the bus can have only one active talker, or communications would be scrambled.

A device is placed in the talk or listen state by sending an appropriate talk or listen command. These talk and listen commands are derived from an instrument's primary address. The primary address may have any value between 0 and 31, and is generally set by rear panel DIP switches or programmed in from the front panel of the instrument. The actual listen address value sent out over the bus is obtained by ORing the primary address with \$20. For example, if the

primary address is \$16, the actual listen address is \$36 ( $\$36 = \$16 + \$20$ ). In a similar manner, the talk address is obtained by ORing the primary address with \$40. With the present example, the talk address derived from a primary address of 16 decimal would be \$56 ( $\$56 = \$16 + \$40$ ).

The IEEE-488 standards also include another addressing mode called secondary addressing. Secondary addresses lie in the range of \$60-\$7F. Note, however, that many devices, including the Model 2002, do not use secondary addressing.

Once a device is addressed to talk or listen, the appropriate bus transactions take place. For example: if the instrument is addressed to talk, it places its data string on the bus one byte at a time. The controller reads the information and the appropriate software can be used to direct the information to the desired location.

## Bus lines

The signal lines on the IEEE-488 bus are grouped into three different categories: data lines, management lines and handshake lines. The data lines handle bus data and commands, while the management and handshake lines ensure that proper data transfer and operation takes place. Each bus line is active low, with approximately zero volts representing a logic 1 (true). The following paragraphs describe the operation of these lines.

### Data lines

The IEEE-488 bus uses eight data lines that transfer data one byte at a time. DIO1 (Data Input/Output) through DIO8 (Data Input/Output) are the eight data lines used to transmit both data and multiline commands and are bidirectional. The data lines operate with low true logic.

### Bus management lines

The five bus management lines help to ensure proper interface control and management. These lines are used to send the uniline commands.

**ATN (Attention)** — The ATN line is one of the more important management lines in that the state of this line determines how information on the data bus is to be interpreted.

**IFC (Interface Clear)** — As the name implies, the IFC line controls clearing of instruments from the bus.

**REN (Remote Enable)** — The REN line is used to place the instrument on the bus in the remote mode.

EOI (End or Identify) — The EOI is usually used to mark the end of a multi-byte data transfer sequence.

SRQ (Service Request) — This line is used by devices when they require service from the controller.

### Handshake lines

The bus handshake lines operate in an interlocked sequence. This method ensures reliable data transmission regardless of the transfer rate. Generally, data transfer will occur at a rate determined by the slowest active device on the bus.

One of the three handshake lines is controlled by the source (the talker sending information), while the remaining two lines are controlled by accepting devices (the listener or listeners receiving the information). The three handshake lines are:

DAV (DATA VALID) — The source controls the state of the DAV line to indicate to any listening devices whether or not data bus information is valid.

NRFD (Not Ready For Data) — The acceptor controls the state of NRFD. It is used to signal to the transmitting device to hold off the byte transfer sequence until the accepting device is ready.

NDAC (Not Data Accepted) — NDAC is also controlled by the accepting device. The state of NDAC tells the source whether or not the device has accepted the data byte.

The complete handshake sequence for one data byte is shown in Figure D-2. Once data is placed on the data lines, the source checks to see that NRFD is high, indicating that all active devices are ready. At the same time, NDAC should be low from the previous byte transfer. If these conditions are not met, the source must wait until NDAC and NRFD have the correct status. If the source is a controller, NRFD and NDAC must be stable for at least 100nsec after ATN is set true. Because of the possibility of a bus hang up, many controllers have time-out routines that display messages in case the transfer sequence stops for any reason.

Once all NDAC and NRFD are properly set, the source sets DAV low, indicating to accepting devices that the byte on the data lines is now valid. NRFD will then go low, and NDAC will go high once all devices have accepted the data. Each

device will release NDAC at its own rate, but NDAC will not be released to go high until all devices have accepted the data byte.

The sequence just described is used to transfer both data, talk and listen addresses, as well as multiline commands. The state of the ATN line determines whether the data bus contains data, addresses or commands as described in the following paragraph.

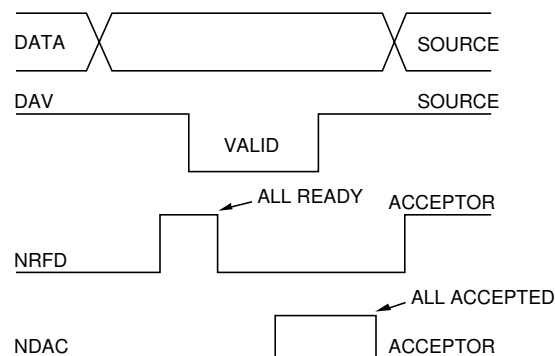

**Figure D-2**  
IEEE-488 handshake sequence

### Bus commands

The instrument may be given a number of special bus commands through the IEEE-488 interface. This section briefly describes the purpose of the bus commands which are grouped into the following three categories.

1. **Uniline Commands** — Sent by setting the associated bus lines true. For example, to assert REN (Remote Enable), the REN line would be set low (true).
2. **Multiline Commands** — General bus commands which are sent over the data lines with the ATN line true (low).
3. **Common Commands** — Commands that are common to all devices on the bus; sent with ATN high (false).
4. **SCPI Commands** — Commands that are particular to each device on the bus; sent with ATN (false).

These bus commands and their general purpose are summarized in Table D-1.

**Table D-1**

IEEE-488 bus command summary

Command type	Command	State of ATN line	Comments
Uniline	REN (Remote Enable)	X	Set up devices for remote operation.
	EOI	X	Marks end of transmission.
	IFC (Interface Clear)	X	Clears interface.
	ATN (Attention)	Low	Defines data bus contents.
	SRQ	X	Controlled by external device.
Multiline Universal	LLO (Local Lockout)	Low	Locks our local operation.
	DCL (Device Clear)	Low	Returns device to default conditions.
	SPE (Serial Enable)	Low	Enables serial polling.
	SPD (Serial Poll Disable)	Low	Disables serial polling.
Addressed	SDC (Selective Device Clear)	Low	Returns unit to default conditions.
	GTL (Go To Local)	Low	Returns device to local.
Unaddressed	UNL (Unlisten)	Low	Removes all listeners from the bus.
	UNT (Untalk)	Low	Removes any talkers from the bus.
Common	—	High	Programs IEEE-488.2 compatible instruments for common operations.
SCPI	—	High	Programs SCPI compatible instruments for particular operations.

**Uniline commands**

ATN, IFC and REN are asserted only by the controller. SRQ is asserted by an external device. EOI may be asserted either by the controller or other devices depending on the direction of data transfer. The following is a description of each command. Each command is sent by setting the corresponding bus line true.

**REN (Remote Enable)** — REN is sent to set up instruments on the bus for remote operation. When REN is true, devices will be removed from the local mode. Depending on device configuration, all front panel controls except the LOCAL button (if the device is so equipped) may be locked out when REN is true. Generally, REN should be sent before attempting to program instruments over the bus.

**EOI (End or Identify)** — EOI is used to positively identify the last byte in a multi-byte transfer sequence, thus allowing data words of various lengths to be transmitted easily.

**IFC (Interface Clear)** — IFC is used to clear the interface and return all devices to the talker and listener idle states.

**ATN (Attention)** — The controller sends ATN while transmitting addresses or multiline commands.

**SRQ (Service Request)** — SRQ is asserted by a device when it requires service from a controller.

**Universal multiline commands**

Universal commands are those multiline commands that require no addressing. All devices equipped to implement such commands will do so simultaneously when the commands are transmitted. As with all multiline commands, these commands are transmitted with ATN true.

**LLO (Local Lockout)** — LLO is sent to the instrument to lock out the LOCAL key and thus all their front panel controls.

**DCL (Device Clear)** — DCL is used to return instruments to some default state. Usually, instruments return to their power-up conditions.

SPE (Serial Poll Enable) — SPE is the first step in the serial polling sequence which is used to determine which device has requested service.

SPD (Serial Poll Disable) — SPD is used by the controller to remove all devices on the bus from the serial poll mode and is generally the last command in the serial polling sequence.

### Addressed multiline commands

Addressed commands are multiline commands that must be preceded by the device listen address before that instrument will respond to the command in question. Note that only the addressed device will respond to these commands. Both the commands and the address preceding it are sent with ATN true.

SDC (Selective Device Clear) — The SDC command performs essentially the same function as the DCL command except that only the addressed device responds. Generally, instruments return to their power-up default conditions when responding to the SDC command.

GTL (Go To Local) — The GTL command is used to remove instruments from the remote mode. With some instruments, GTL also unlocks front panel controls if they were previously locked out with the LLO command.

GET (Group Execute Trigger) — The GET command is used to trigger devices to perform a specific action that depends on device configuration (for example, take a reading). Although GET is an addressed command, many devices respond to GET without addressing.

### Address commands

Addressed commands include two primary command groups and a secondary address group. ATN is true when these commands are asserted. The commands include:

LAG (Listen Address Group) — These listen commands are derived from an instrument's primary address and are used to address devices to listen. The actual command byte is obtained by ORing the primary address with \$20.

TAG (Talk Address Group) — The talk commands are derived from the primary address by ORing the address with \$40. Talk commands are used to address devices to talk.

SCG (Secondary Command Group) — Commands in this group provide additional addressing capabilities. Many devices (including the Model 2002) do not use these commands.

### Unaddress commands

The two unaddress commands are used by the controller to remove any talkers or listeners from the bus. ATN is true when these commands are asserted.

UNL (Unlisten) — Listeners are placed in the listener idle state by the UNL command.

UNT (Untalk) — Any previously commanded talkers will be placed in the talker idle state by the UNT command.

### Common commands

Common commands are commands that are common to all devices on the bus. These commands are designated and defined by the IEEE-488.2 standard.

Generally, these commands are sent as one or more ASCII characters that tell the device to perform a common operation, such as reset. The IEEE-488 bus treats these commands as data in that ATN is false when the commands are transmitted.

### SCPI commands

SCPI commands are commands that are particular to each device on the bus. These commands are designated by the instrument manufacturer, and are based on the instrument model defined by the Standard Commands for Programmable Instruments (SCPI) Consortium's SCPI standard.

Generally, these commands are sent as one or more ASCII characters that tell the device to perform a particular operation, such as setting a range or closing a relay. The IEEE-488 bus treats these commands as data in that ATN is false when the commands are transmitted.

### Command codes

Command codes for the various commands that use the data lines are summarized in Figure D-3. Hexadecimal and the decimal values for the various commands are listed in Table D-2.

D <sub>7</sub> D <sub>6</sub> D <sub>5</sub> D <sub>4</sub>	X 0 0 0	Command 1 (A)	X 0 0 1	Command 1 (B)	X 0 1 0	Primary Address 2 (B)	X 0 1 1	Primary Address 3 (B)	X 0 1 1	Primary Address 4 (A)	X 0 1 1	Primary Address 5 (B)	X 0 1 1 0	Primary Address 6 (A)	X 1 1 1 1	Primary Address 7 (B)	
																	Bits
	D <sub>3</sub> ↓	0 (A)	0 (B)	1 (A)	2 (A)	3 (A)	4 (A)	4 (A)	5 (A)	6 (A)	7 (A)						
	D <sub>2</sub> ↓	0	0	1	0	2	3	4	5	6	7						
	D <sub>1</sub> ↓	0	0	0	1	1	2	3	4	5	6						
	D <sub>0</sub> ↓	0	0	0	1	1	2	3	4	5	6						
	Column →	0	1	2	3	4	5	6	7	8	9	10	11	12	13	14	15
	Row ↓	NUL	GTL	DLE	SP	0	16	@	0	P	16						
		SOH	DC1	DC1	!	1	17	A	1	Q	17	a					
		STX	DC2	DC2	"	2	18	B	2	R	18	b					
		ETX	DC3	DC3	#	3	19	C	3	S	19	c					
		EOT	DC4	DC4	\$	4	20	D	4	T	20	d					
		ENQ	PPC*	NAK	%	5	21	E	5	U	21	e					
		ACK		SYN	&	6	22	F	6	V	22	f					
		BEL		ETB	'	7	23	G	7	W	23	g					
		BS	GET	CAN	(	8	24	H	8	X	24	h					
		HT	TCT*	EM	)	9	25	I	9	Y	25	i					
		LF		SUB	.	10	26	J	10	Z	26	j					
		VT		ESC	+	11	27	K	11	[	27	k					
		FF		FS	,	12	28	L	12	\	28	l					
		CR		GS	-	13	29	M	13	]	29	m					
		SO		RS	.	14	30	N	14	^	30	n					
		S		US	/	15	UNL	O	15	_	UNT	o					

\*PPC (PARALLEL POLL CONFIGURE) PPU (PARALLEL POLL UNCONFIGURE), and TCT (TAKE CONTROL) not implemented by Model 2002.  
 Note: D<sub>0</sub> = DIO1 ... D<sub>7</sub> = DIO8; X = Don't Care.

Figure D-3  
 Command codes



**Table D-2**  
Hexadecimal and decimal command codes

Command	Hex value	Decimal value
GTL	01	1
SDC	04	4
GET	08	8
LLO	11	17
DCL	14	20
SPE	18	24
SPD	19	25
LAG	20-3F	32-63
TAG	40-5F	64-95
SCG	60-7F	96-127
UNL	3F	63
UNT	5F	95

### Typical command sequences

For the various multiline commands, a specific bus sequence must take place to properly send the command. In particular, the correct listen address must be sent to the instrument before it will respond to addressed commands. Table D-3 lists a typical bus sequence for sending the addressed multiline commands. In this instance, the SDC command is being sent to the instrument. UNL is generally sent as part of the sequence to ensure that no other active listeners are present. Note that ATN is true for both the listen command and the SDC command byte itself.

Table D-4 gives a typical common command sequence. In this instance, ATN is true while the instrument is being addressed, but it is set high while sending the common command string.

### IEEE command groups

Command groups supported by the Model 2002 are listed in Table D-5. Common commands and SCPI commands are not included in this list.

**Table D-3**  
Typical addressed command sequence

Step	Command	ATN state	Data bus		
			ASCII	Hex	Decimal
1	UNL	Set low	?	3F	63
2	LAG*	Stays low	0	30	48
3	SDC	Stays low	EOT	04	4
4		Returns high			

\*Assumes primary address = 16.

**Table D-4**  
Typical common command sequence

Step	Command	ATN state	Data bus		
			ASCII	Hex	Decimal
1	UNL	Set low	?	3F	63
2	LAG*	Stays low	0	30	48
3	Data	Set high	*	2A	42
4	Data	Stays high	R	52	82
5	Data	Stays high	S	53	83
6	Data	Stays high	T	54	84

\*Assumes primary address = 16.

**Table D-5**  
*IEEE command groups*

<b>HANDSHAKE COMMAND GROUP</b>	
	NDAC = NOT DATA ACCEPTED NRFD = NOT READY FOR DATA DAV = DATA VALID
<b>UNIVERSAL COMMAND GROUP</b>	
	ATN = ATTENTION DCL = DEVICE CLEAR IFC = INTERFACE CLEAR REN = REMOTE ENABLE SPD = SERIAL POLL DISABLE SPE = SERIAL POLL ENABLE
<b>ADDRESS COMMAND GROUP</b>	
LISTEN	LAG = LISTEN ADDRESS GROUP MLA = MY LISTEN ADDRESS UNL = UNLISTEN
TALK	TAG = TALK ADDRESS GROUP MTA = MY TALK ADDRESS UNT = UNTALK OTA = OTHER TALK ADDRESS
<b>ADDRESSED COMMAND GROUP</b>	
	ACG = ADDRESSED COMMAND GROUP GTL = GO TO LOCAL SDC = SELECTIVE DEVICE CLEAR
<b>STATUS COMMAND GROUP</b>	
	RQS = REQUEST SERVICE SRQ = SERIAL POLL REQUEST STB = STATUS BYTE EOI = END

# IEEE-488 Conformance Information

## Information

The IEEE-488.2 standard requires specific information about how the Model 2002 implements the standard. Paragraph 4.9 of the IEEE-488.2 standard (Std 488.2-1987) lists the documentation requirements. Table E-1 provides a summary of the requirements, and provides the information or references the manual for that information.

**Table E-1**

*IEEE-488 documentation requirements*

	Requirement	Description or reference
(1)	IEEE-488 Interface Function Codes.	See Appendix B.
(2)	Behavior of 2002 when the address is set outside the range 0-30.	Cannot enter an invalid address.
(3)	Behavior of 2002 when valid address is entered.	Address changes and bus resets.
(4)	Power-On Setup Conditions.	Determine by :SYSTem:POSetup (para. 3.21.2).
(5)	Message Exchange Options:	
(a)	Input buffer size.	256 bytes.
(b)	Queries that return more than one response message unit.	None.
(c)	Queries that generate a response when parsed.	All queries (Common Commands and SCPI).
(d)	Queries that generate a response when read.	None.
(e)	Coupled commands.	See Table E-2.
(6)	Functional elements required for SCPI commands.	Contained in SCPI command subsystems tables (see Tables 3-4 through 3-16).
(7)	Buffer size limitations for block data.	Block display messages: Top display = 20 characters max, bottom display = 32 characters max.
(8)	Syntax restrictions.	See paragraphs 3.10 through 3.24.
(9)	Response syntax for every query command.	See paragraphs 3.10 through 3.24.
(10)	Device-to-device message transfer that does not follow rules of the standard.	None.
(11)	Block data response size.	See paragraph 3.13.
(12)	Common Commands implemented by 2002.	See paragraph 3.10.
(13)	Calibration query information.	See Calibration Manual.
(14)	Trigger macro for *DDT.	Not applicable.
(15)	Macro information.	Not applicable.

**Table E-1 (cont.)**

IEEE-488 documentation requirements

	<b>Requirement</b>	<b>Description or reference</b>
(16)	Response to *IDN (identification).	See paragraph 3.10.4.
(17)	Storage area for *PUD and *PUD?	Not applicable.
(18)	Resource description for *RDT and *RDT?	Not applicable.
(19)	Effects of *RST, *RCL and *SAV.	See paragraphs 3.10.9, 3.10.8, 3.10.10, and Tables 3-4 through 3-16.
(20)	*TST information.	See paragraph 3.10.14.
(21)	Status register structure.	See paragraph 3.7.
(22)	Sequential or overlapped commands.	All are sequential except :INIT and :INIT:CONT ON, which are overlapped.
(23)	Operation complete messages.	*OPC; see paragraph 3.10.5, *OPC?; see paragraph 3.10.6, *WAI; see paragraph 3.10.15.

**Table E-2**  
Coupled commands

Command	Also changes	To	If
:SYST:AMET BURS	... :RANG:AUTO ... :NPLC ... :APER ... :DIG:AUTO ... :DIG ... :AVER:AUTO ... :AVER:TCON :INIT:CONT :SYST:AZER:STAT :ARM:LAY1:COUN :ARM:LAY2:COUN :TRIG:COUN :TRACe:EGR :TRACe:FEED :TRACe:FEED:CONT	OFF 0.01 0.01 / line-frequency OFF 4 OFF MOV OFF OFF 1 1 TRACe:POIN COMP CALC1 NEXT	TRACe:FEED is NONE
:SYST:AMET:ASTR and :SYST:AMET:SSTR	:SYST:AZER:STAT :SYST:LSYN:STAT :CALC:STAT ... :RANG:AUTO ... :NPLC ... :NPLC:AUTO ... :DIG ... :DIG:AUTO ... :AVER:STAT ... :AVER:AUTO ... :REF:STAT	OFF OFF OFF OFF 0.01 OFF 4 OFF OFF OFF OFF	
:TRIG:COUN	:TRAC:POIN:AUTO  :TRAC:POIN :TRAC:FEED:PRET:AMO:READ	OFF  TRIG:COUN TRIG:COUN * TRAC:FEED:PRET:AMO:PERC / 100	TRAC:POIN:AUTO is ON and TRIG:COUN is an illegal buffer size TRAC:POIN:AUTO is ON TRAC:POIN:AUTO is ON
:TRAC:FEED:CONT	:TRIG:SOUR	TIM	TRAC:FEED:CONT is PRET and TRIG:SOUR is neither IMM nor TIM
:TRAC:POIN	:TRAC:POIN:AUTO :TRAC:FEED:CONT :TRAC:FEED:PRET:AMO:READ  :TRIG:COUN	OFF NEV TRAC:POIN * TRAC :FEED:PRET:AMO :PERC / 100 TRAC:POIN	SYST:AMET is BURS

**Table E-2 (cont.)**  
Coupled commands

Command	Also changes	To	If
:TRAC:FEED:PRET:AMO:PERC	:TRAC:FEED:PRET:AMO:READ	TRAC:POIN * TRAC :FEED:PRET:AMO :PERC / 100 NEV	
:TRAC:FEED:PRET:AMO:READ	:TRAC:FEED:CONT	TRAC:FEED:PRET: AMO:READ / TRAC :POIN * 100 NEV	
:TRAC:EGR	:TRAC:FEED:CONT	NEV	
:TRAC:CLE	:TRAC:FEED:CONT	NEV	
:UNIT:VOLT:AC	:VOLT:AC:AVER:STAT	varies per units	VOLT:AC:AVER:AUTO is ON
	:VOLT:AC:AVER:COUN	varies per function	VOLT:AC:AVER:AUTO is ON
	:VOLT:AC:AVER:TCON	varies per function	VOLT:AC:AVER:AUTO is ON
	:VOLT:AC:AVER:ADV:STAT	varies per function	VOLT:AC:AVER:AUTO is ON
	:VOLT:AC:AVER:ADV:NTOL	varies per function	VOLT:AC:AVER:AUTO is ON
:FUNC :ROUT:OPEN:ALL			function is 4-wire and closed channel > 5
...:APER	...:APER:AUTO ...:NPLC:AUTO ...:NPLC ...:DIG	OFF OFF APER*line-frequency varies per function	...:DIG:AUTO is ON
...:NPLC	...:APER:AUTO ...:NPLC:AUTO ...:APER ...:DIG	OFF OFF NPLC/line-frequency varies per function	...:DIG:AUTO is ON
...:DIG	...:DIG:AUTO ...:APER ...:NPLC	OFF varies per function varies per function	...:APER:AUTO is ON ...:NPLC:AUTO is ON
...:RANG:UPP	...:RANG:AUTO	OFF	
...:REF:ACQ	...:REF	presently displayed reading	
...:AVER:STAT	...:AVER:AUTO	OFF	
...:AVER:COUN	...:AVER:AUTO	OFF	
...:AVER:TCON	...:AVER:AUTO	OFF	
...:AVER:ADV:NTOL	...:AVER:AUTO	OFF	
...:AVER:ADV:STAT	...:AVER:AUTO	OFF	

**Table E-2 (cont.)**  
Coupled commands

Command	Also changes	To	If
...:DET:FUNC	...:APER ...:DIG ...:AVER:STAT ...:AVER:COUN n ...:AVER:TCON n ...:AVER:ADV:STAT n ...:AVER:ADV:NTOL n	varies per function varies per function varies per function varies per functio varies per functio varies per functio varies per functio	...APER:AUTO is ON ...DIG:AUTO is ON ...AVER:AUTO is ON ...AVER:AUTO is ON ...AVER:AUTO is ON ...AVER:AUTO is ON ...AVER:AUTO is ON
:RES:OCOM	:RES:RANG:UPP  :RES:RANG:AUTO:ULIM  :RES:RANG:AUTO:LLIM	200k  200k  200k	RES:OCOM is ON and RES:RANG:UPP > 200k RES:OCOM is ON and RES:RANG:AUTO:ULI M > 200k RES:OCOM is ON and RES:RANG:AUTO:LLI M > 200k
:CURR:DC:METH	:CURR:DC:RANG:UPP :CURR:DC:RANG:AUTO :CURR:DC:AVER:STAT  :CURR:DC:AVER:COUN  :CURR:DC:AVER:TCON  :CURR:DC:AVER:ADV:STAT  :CURR:DC:AVER:ADV:NTOL	12 OFF varies per function  varies per function  varies per function  varies per function  varies per function	CURR:DC:METH is ICIR CURR:DC:METH is ICIR CURR:DC:AVER:AUTO is ON CURR:DC:AVER:AUTO is ON CURR:DC:AVER:AUTO is ON CURR:DC:AVER:AUTO is ON CURR:DC:AVER:AUTO is ON
:FREQ:THR:VOLT:TTL	:FREQ:THR:VOLT:RANG :FREQ:THR:VOLT:LEV	10 0.8	
:TEMP:TRAN	:ROUT:SCAN:INT  :ROUT:SCAN:INT:FUNC  :TEMP:DIG	very complicated algo- rithm very complicated algo- rithm varies per transducer	TEMP:DIG:AUTO is ON
:TEMP:RTD:TYPE	:TEMP:RTD:ALPH  :TEMP:RTD:BETA  :TEMP:RTD:DELT  :TEMP:RTD:RZER	varies per RTD type  varies per RTD type  varies per RTD type  varies per RTD type	TEMP:RTD:TYPE is not USER TEMP:RTD:TYPE is not USER TEMP:RTD:TYPE is not USER TEMP:RTD:TYPE is not USER
:TEMP:RTD:ALPH	:TEMP:RTD:TYPE	USER	

**Table E-2 (cont.)**  
Coupled commands

Command	Also changes	To	If	
:TEMP:RTD:BETA	:TEMP:RTD:TYPE	USER	TEMP:DIG:AUTO is ON	
:TEMP:RTD:DELT	:TEMP:RTD:TYPE	USER		
:TEMP:RTD:RZER	:TEMP:RTD:TYPE	USER		
:TEMP:TC:TYPE	:TEMP:DIG	varies per TC type		
:ROUT:CLOS	:ROUT:SCAN:LSEL	NONE		
:ROUT:OPEN	:ROUT:SCAN:LSEL	NONE		
:ROUT:OPEN:ALL	:ROUT:SCAN:LSEL	NONE		
:ROUT:SCAN:INT	:ROUT:SCAN:LSEL	INT		
:ROUT:SCAN:RAT:FUNC	...:AVER:STAT ...:AVER:COUN ...:AVER:TCON ...:AVER:ADV:STAT ...:AVER:ADV:NTOL n	varies per function varies per function varies per function varies per function varies per functio		...AVER:AUTO is ON ...AVER:AUTO is ON ...AVER:AUTO is ON ...AVER:AUTO is ON ...AVER:AUTO is ON
:ROUT:SCAN:LSEL	...:AVER:STAT varies per function ...:AVER:COUN ...:AVER:TCON ...:AVER:ADV:STAT ...:AVER:ADV:NTOL :FUNC  :FUNC  :ROUT:CLOS  :ROUT:CLOS	varies per function varies per function varies per function varies per function varies per function  :ROUT:SCAN:RAT:FU NC :ROUT:SCAN:DELT :FUNC :ROUT:SCAN:RAT :MCH :ROUT:SCAN:DELT :MCH		...AVER:AUTO is ON ...AVER:AUTO is ON ...AVER:AUTO is ON ...AVER:AUTO is ON ...AVER:AUTO is ON ROUT:SCAN:LSEL is RAT ROUT:SCAN:LSEL is DELT ROUT:SCAN:LSEL is RAT ROUT:SCAN:LSEL is DELT

... = Valid function command words (i.e. :VOLT:DC, :VOLT:AC, etc.)



# SCPI Conformance Information

---

## Introduction

The Model 2002 complies with SCPI version 1991.0. Tables 3-4 through 3-16 list the SCPI confirmed commands, and the non-SCPI commands implemented by the Model 2002.

# G

## Example Programs

---

The following programs demonstrate various aspects of Model 2002 operation. Most programs use only the Model 2002 while some include additional equipment, such as the Model 2001-SCAN Scanner Card or a Model 7001 (or 7002) Switch System.

The programs are written in Microsoft QuickBASIC 4.5 or Microsoft QuickC 2.0. Most examples use the Keithley (CEC) IEEE-488 interface cards. Other interfaces used include IOtech and National GPIB.

## Measure and Display Reading; :MEASure? Command

### Microsoft QuickBASIC 4.5 Keithley KPC-488.2 Interface

©1992, Keithley Instruments, Inc.

#### Description

Every time this program is run, the Model 2002 goes to the most sensitive DCV range and makes a single measurement using the :MEASure command. The reading is then displayed on the computer CRT.

#### Required equipment

- Model 2002 Multimeter

- Microsoft QuickBASIC 4.5
- Any one of the following IEEE-488 interfaces:
  - Keithley Model KPC-488.2
  - Keithley Model KPC-488.2AT
  - Capital Equipment Corporation PC<>488

The program assumes that the Model 2002 is set to address 16.

#### Loading user library

The user library for QuickBASIC 4.5 is provided with the IEEE-488 interface (ieeeqb.qlb). Assuming QuickBASIC and the user library are in the same DOS directory, enter the following command line from the DOS prompt:

```
QB /L ieeeqb.qlb
```

The above command line will load QuickBASIC and the user library.

---

#### Program (2002tst.bas)

```
CALL initialize(21, 0) ' Init as system controller
'MODEL 2002 COMMANDS
CALL send(16, "*CLS", Gpib.status%)
CALL send(16, ":meas:volt:dc?", Gpib.status%) ' Measure DCV
data$ = SPACE$(80)
CALL enter(data$, Gpib.len%, 16, Gpib.status%)
PRINT data$ ' Display reading
END
```

## Measure and Display Reading; :READ? Command

### Microsoft QuickBASIC 4.5 Keithley KPC-488.2 Interface

©1992, Keithley Instruments, Inc.

#### Description

Every time this program is run, the Model 2002 goes to the DCV range and makes a single measurement using the :READ? command. The reading is then displayed on the computer CRT.

#### Required equipment

- Model 2002 Multimeter
- Microsoft QuickBASIC 4.5

- Any one of the following IEEE-488 interfaces:  
Keithley Model KPC-488.2  
Keithley Model KPC-488.2AT  
Capital Equipment Corporation PC<>488

The program assumes that the Model 2002 is set to address 16.

#### Loading user library

The user library for QuickBASIC 4.5 is provided with the IEEE-488 interface (ieeeqb.qlb). Assuming QuickBASIC and the user library are in the same DOS directory, enter the following command line from the DOS prompt:

```
QB /L ieeeqb.qlb
```

The above command line will load QuickBASIC and the user library.

---

#### Program (2002rdg.bas)

```
k2002data$ = SPACE$(35)
CALL Initialize(21, 0) ' Init as system controller

'--- Setup 2002 measurement mode
CLS
CALL SETOUTPUTEOS(10, 0)
CALL SETINPUTEOS(10)
CALL SEND(16, ":init:cont off", gpib.status%) ' Disable continuous
 ' initiation
CALL SEND(16, ":sens:func 'volt:dc' ", gpib.status%) ' Select DCV
CALL SEND(16, ":sens:volt:dc:dig 8", gpib.status%) ' Select 7 1/2 digit
 ' resolution

k2001data$ = SPACE$(255)
CALL SEND(16, ":read?", gpib.status%) ' Perform measurement
CALL Enter(k2001data$, Gpib.len%, 16, gpib.status%)
k2001data$ = LEFT$(k2001data$, Gpib.len%) ' Display reading
PRINT k2001data$
END
```

## :CONFigure and :READ? Commands

### Microsoft QuickC 2.0 National GPIB PC Interface

©1992, Keithley Instruments, Inc.

#### Description

This program demonstrates the use of the :CONFigure and :READ? commands. In general, :CONFigure is used to select the FREQ function and then performs a \*RST. The :READ? command is used to make a measurement, which is

then sent to the computer and displayed. This process continues until a keystroke occurs.

#### Required equipment

- Model 2002 Multimeter
- Microsoft QuickC 2.0
- National GPIB PC Interface (interface software must be installed and configured as explained in the instruction manual).

The program assumes that the Model 2002 is set to address 16.

---

#### Program (confnat.c)

```
#include <stc.h>
#include <stdio.h>
#include <stdlib.h>
#include <decl.h>
#include <math.h>
#include <graph.h>
#include <string.h>
#include <time.h>

#define k2002 16

main()
{
 int stat, l;

 char status, keych;
 char cmd[255];
 char ki2002[10];

 _clearscreen(_GWINDOW);
 SendIFC(0); /* Set Controller to Addr 0 */

 Send(0,k2002,":form:elem read",24L,NLend); /* Include only reading in data string */

 while(!kbhit())
 {
 Send(0,k2002,":conf:freq",20L,NLend); /* Configure for one-shot FREQ measurements */
 Send(0,k2002,":read?",6L,NLend); /* Make measurement */
 Receive(0,k2002,ki2002,20L,STOPend);
 printf("%s",ki2002); /* Display reading */
 }
}
```

## Display User Defined Message

### Microsoft QuickBASIC 4.5 Keithley KPC-488.2 Interface

©1992, Keithley Instruments, Inc.

#### Description

This program simply displays a user defined message on the display of the Model 2002.

#### Required equipment

- Model 2002 Multimeter
- Microsoft QuickBASIC 4.5
- Any one of the following IEEE-488 interfaces:

Keithley Model KPC-488.2  
Keithley Model KPC-488.2AT  
Capital Equipment Corporation PC<>488

The program assumes that the Model 2002 is set to address 16.

#### Loading user library

The user library for QuickBASIC 4.5 is provided with the IEEE-488 interface (ieeeqb.qlb). Assuming QuickBASIC and the user library are in the same DOS directory, enter the following command line from the DOS prompt:

```
QB /L ieeeqb.qlb
```

The above command line will load QuickBASIC and the user library.

---

#### Program (2002disp.bas)

```
CALL Initialize(21, 0) ' Init as system controller
'--- Setup 2002 commands
CLS

' Enable message mode

CALL Send(16, ":disp:text:stat on", Gpib.status%)

' Display first message

CALL Send(16, ":disp:text:data 'GOOD MORNING!' ", Gpib.status%)
SLEEP 2

' Display second message

CALL Send(16, ":disp:text:data 'HOW ARE YOU TODAY?' ", Gpib.status%)

END
```

## Four-Wire Ohms Measurements

### Microsoft QuickBASIC 4.5 IOtech Interface and Driver-488 Software

©1992, Keithley Instruments, Inc.

#### Description

This program configures the Model 2002 to make four-wire ohms measurements. The Model 2002 makes five measurements, stores them in its internal buffer and then sends them to the computer where the readings are displayed. This process continues until a keystroke occurs to stop the program.

This program configures the Model 2002 as follows:

Function:  $\Omega 4$   
Filter: Repeat averaging mode, 5 readings  
Resolution: 7 1/2 digits

#### Required equipment

- Model 2002 Multimeter
- Microsoft QuickBASIC 4.5
- IOtech GP488B IEEE-488 Interface
- IOtech Driver488 Software (installed and configured as described in the instruction manual for the interface).

The program assumes that the Model 2002 is set to address 16.

---

#### Program (ohmsbufi.bas)

```
OPEN "\dev\ieeeeout" FOR OUTPUT AS #1 ' Open GP488B for output
IOCTL #1, "break" ' Reset Personal488
PRINT #1, "reset"
OPEN "\dev\ieeeein" FOR INPUT AS #2 ' Open GP488B for input
CLS
PRINT #1, "TIME OUT 5"
PRINT #1, "TERM OUT LF EOI"
PRINT #1, "TERM IN LF EOI"

'--- Set up 2002 for 5 readings, 7.5 digits, 4-wire ohms, 10 NPLC, store
' readings in buffer, return buffered readings to host computer and then
'repeat the process.

PRINT #1, "Output 16; *RST" ' Perform reset

PRINT #1, "Output 16; :sens:func 'fres';" ' Set for 4-wire ohms

cmd$ = ":sens:fres:nplc 10; dig 7.5; aver:coun 5; tcon rep;"
cmd$ = cmd$ + "Stat On"

' Set for 10 PLC,
' 7.5 digits, average
' 5 readings, repeat mode

PRINT #1, "Output 16;"; cmd$

PRINT #1, "Output 16; :form:elem read" ' Return readings only
cmd$ = ":init:cont off; :abor; :trac:cle" ' Turn off trigger model,
' Clear data buffer

PRINT #1, "Output 16;"; cmd$

cmd$ = ":arm:seq1:lay1:sour bus; coun 1; :arm:seq1:lay2:sour imm;"
cmd$ = cmd$ + ":trig:seq1:sour imm; coun 5; :stat:meas:PTR 512; NTR 0"
' Set the 2002 to start
' taking readings on a
' bus trigger. Set Measure
' Event Register to flag
' on buffer full.

PRINT #1, "Output 16;"; cmd$
```

**Program (ohmsbufi.bas) (cont.)**

```

PRINT #1, "Output 16; *CLS" ' Clear 2002

cmd$ = ":trac:feed sens; poin 5; feed:cont next;"
cmd$ = cmd$ + ":init:cont on" ' Set up buffer to store
 ' 5 points after averaging,
 ' arm 2002.

PRINT #1, "Output 16;"; cmd$

PRINT #1, "Output 16; *TRG" ' Trigger 2002 to start

PRINT "Data collection in progress....."

DO
PRINT #1, "Output 16; :stat:meas:even?" ' Check to see if the buffer
 ' is full.
PRINT #1, "Enter 16" ' Get status value
LINE INPUT #2, pollval$
LOOP UNTIL (VAL(pollval$) AND 512) = 512

resistance$ = SPACE$(100)
PRINT #1, "Output 16; :trac:data?" ' Get data
PRINT #1, "Enter 16"
LINE INPUT #2, resistance$

FOR x = 0 TO 4
reading$ = MID$(resistance$, x * 15 + 1, 13)
PRINT reading$
NEXT x

cmd$ = ":init:cont off; :abor; :trace:cle" ' Turn off trigger model,
 ' Clear data buffer

PRINT #1, "Output 16;"; cmd$
END

```



## Test Digital Input Port

### Microsoft QuickBASIC 4.5 Keithley KPC-488.2 Interface

©1992, Keithley Instruments, Inc.

#### Description

This program continuously tests the digital input port of the Model 2002. Each test provides the status of the read operation. If Status = 0, then the read operation was successful. Also displayed is the result of the read operation. If the digital input port is high (on), then Databyte = 1. Conversely, if the input port is low (off), then Databyte = 0.

Pressing any key on the computer keyboard terminates the program.

#### Required equipment

- Model 2002 Multimeter

- Microsoft QuickBASIC 4.5
- Any one of the following IEEE-488 interfaces:
  - Keithley Model KPC-488.2
  - Keithley Model KPC-488.2AT
  - Capital Equipment Corporation PC<>488

The program assumes that the Model 2002 is set to address 16.

#### Loading user library

The user library for QuickBASIC 4.5 is provided with the IEEE-488 interface (ieeeqb.qlb). Assuming QuickBASIC and the user library are in the same DOS directory, enter the following command line from the DOS prompt:

```
QB /L ieeeqb.qlb
```

The above command line will load QuickBASIC and the user library.

---

#### Program (testdio2.bas)

```
'$INCLUDE: 'ieeeqb.bi'
CLS
CALL initialize(21, 0)
CALL SETTIMEOUT(1000)
CALL setoutputEOS(10, 0)
CALL setinputEOS(10)
CALL send(16, "*RST; *CLS; :syst:pres", status%)' Clear and reset 2002
z = 0
rdata$ = SPACE$(8)
WHILE INKEY$ = ""
 z = z + 1
 CALL send(16, ":sens2:ttl1:data?", status%)
 GOSUB test.status
 t! = TIMER: WHILE TIMER - t! <= .5: WEND
 CALL enter(rdata$, 3, 16, status%)
 GOSUB test.status
 PRINT "Test #"; z; " Status "; status%; " Databyte "; rdata$
WEND

test.status:

 IF status% <> 0 THEN
 PRINT " Failure on IEEE-Bus !!! Status = "; status%
 SLEEP 3
 STOP
 END IF
 RETURN
```

```
' Press any key to end program
' Read input port

' Check integrity of read operation
' Display status and state of input
' port END
' Print error message and stop
' program if the read operation is
' corrupt (1)
```

## High Speed Data Transfer Over Bus

### Microsoft QuickBASIC 4.5 Keithley KPC-488.2 Interface

©1992, Keithley Instruments, Inc.

#### Description

This program demonstrates how fast the Model 2002 can make measurements and send them to the computer. Speed is optimized by configuring the Model 2002 as follows:

Function/Range: 20 VDC  
Auto Zero: Off  
Autorange: Off  
Resolution: 4 1/2 digits  
Acquisition Method: ASTREAM  
Display: Disabled

This program will take 1000 measurements on the 20VDC range and send them to the computer. The total elapsed time (in seconds) to take the readings and send them to the computer is displayed on the computer CRT. The rate (readings per second) is also calculated and displayed.

When the prompt (?) is displayed on the computer CRT, press Enter to display the 1000 readings.

#### Required equipment

- Model 2002 Multimeter
- Microsoft QuickBASIC 4.5
- Any one of the following IEEE-488 interfaces:
  - Keithley Model KPC-488.2
  - Keithley Model KPC-488.2AT
  - Capital Equipment Corporation PC<>488

The program assumes that the Model 2002 is set to address 16.

#### Loading user library

The user library for QuickBASIC 4.5 is provided with the IEEE-488 interface (ieeeqb.qlb). Assuming QuickBASIC and the user library are in the same DOS directory, enter the following command line from the DOS prompt:

```
QB /L ieeeqb.qlb
```

The above command line will load QuickBASIC and the user library.

---

#### Program (astream.bas)

```
'$INCLUDE: 'ieeeqb.bi'
DIM rdg!(1000)
CALL initialize(21, 0)
CALL setoutputEOS(10, 0)
CALL setinputEOS(10)
CALL settimeout(5000)
cmd$ = ":syst:pres"
GOSUB sendcmd
cmd$ = ":init:cont off; :abor"
GOSUB sendcmd
cmd$ = ":syst:azer:stat off"
GOSUB sendcmd
cmd$ = ":init:cont on"
GOSUB sendcmd
cmd$ = ":sens:func 'Volt:DC'"
GOSUB sendcmd

cmd$ = ":sens:volt:dc:dig 4.5; rang:auto off" ' Set for 4.5 Digits
 ' Autoranging off

GOSUB sendcmd

cmd$ = ":sens:volt:dc:rang:upp 20"
GOSUB sendcmd ' Set for 20VDC Range

' PC controller at 21
' Set Input EOS to LF
' Set Output EOS to LF
' Set timeout 5 seconds
' Reset 2002

' Stop Trigger Model

' Turn Autozero off

' Start Trigger Model

' Set 2002 for DCV
```

### Program (astream.bas) (cont.)

```
cmd$ = ":sens:volt:dc:aver:stat off; adv:stat off; :init:cont on"
GOSUB sendcmd
cmd$ = ":syst:amet astr"
GOSUB sendcmd
SLEEP 1
CLS
PRINT "Test in Progress....."
r$ = SPACE$(16)
t1 = TIMER
FOR x = 1 TO 1000
CALL enter(r$, length%, 16, status%)
rdg!(x) = VAL(r$)
NEXT x
t2 = TIMER

PRINT "Starting Time = "; t1
PRINT "Ending Time = "; t2
PRINT "Elapsed Time = "; t2 - t1
PRINT "Readings Per Second = "; 1 / ((t2 - t1) / 1000)

CALL transmit("listen 16 sdc", status%)
SLEEP 1
INPUT zz$
FOR x = 1 TO 1000
PRINT rdg!(x)
IF rdg!(x) > 30 THEN BEEP: BEEP: BEEP
NEXT x
END

sendcmd:
CALL send(16, cmd$, status%)
IF status% <> 0 THEN
PRINT status%
STOP
END IF
RETURN
```

## Binary Data Transfer

### Microsoft QuickC 2.0 Keithley KPC-488.2 Interface

©1992, Keithley Instruments, Inc.

#### Description

This program demonstrates the binary data transfer capability of the Model 2002. The Model 2002 sends binary readings to the computer using the IEEE754 Single Precision Data Format.

#### Required equipment

- Model 2002 Multimeter
- Microsoft QuickC 2.0

- Any one of the following IEEE-488 interfaces:  
Keithley Model KPC-488.2  
Keithley Model KPC-488.2AT  
Capital Equipment Corporation PC<>488

The program assumes that the Model 2002 is set to address 16.

#### Linking program with library

After writing and compiling the program, you will have to link it with the library support files provided with the IEEE-488 interface. From the DOS prompt, enter the following command line:

```
CL myprog.c /link ieee488
```

The above command line will link your program to the library. The program can now be run using QuickC.

#### Program (bintran.c)

```
#include <stdio.h>
#include <stdlib.h>
#include <string.h>
#include <ieee-c.h>
#define K2002 16/* IEEE address of 2002 */
main ()
{
 int status, l;
 char r[80];
 float meas;
 float dummy;
 initialize (21,0);
 setinputEOS (10); setoutputEOS (10,0);
 send (K2002,"*IDN?",&status);
 enter (r,80,&l,K2002,&status);
 printf ("Data received=%s\n",r);
 send (K2002,"syst:pres",&status);
 send (K2002,"form:elem read",&status);
 send (K2002,"form:data sre; bord swap",&status);

 while (1) {
 send (K2002,"fetch?",&status);
 transmit ("MLA TALK 16",&status);
 rarray (&meas,5,&l,&status);
 printf ("Data received=%e\n",meas);
 }
}
/* PC controller @ address 2 */
/* Set EOS for input & output */
/* Query 2002 for ID string */
/* Get ID string */
/* Print response. */
/* Power Up reset */
/* Readings only */
/* Single precision reals, byte
 order swapped. */
/* Loop */
/* Fetch a reading */
/* Put 2002 in talk mode */
/* Get reading */
/* Print reading */
```

## Scan High Speed Channels; Model 2001-SCAN

### Microsoft QuickBASIC 4.5 Keithley KPC-488.2 Interface

©1992, Keithley Instruments, Inc.

#### Description

This program scans and measures (DCV) the two high speed channels (ch 5 and 10) of the Model 2001-SCAN Scanner Card. The 2-channel scan keeps repeating until the buffer of the Model 2002 is filled. The readings are then sent to the computer where they are displayed.

#### Required equipment

- Model 2001 Multimeter
- Model 2001-SCAN Scanner Card (installed in the Model 2002)

- Microsoft QuickBASIC 4.5
- Any one of the following IEEE-488 interfaces:
  - Keithley Model KPC-488.2
  - Keithley Model KPC-488.2AT
  - Capital Equipment Corporation PC<>488

The program assumes that the Model 2002 is set to address 16.

#### Loading user library

The user library for QuickBASIC 4.5 is provided with the IEEE-488 interface (ieeeqb.qlb). Assuming QuickBASIC and the user library are in the same DOS directory, enter the following command line from the DOS prompt:

```
QB /L ieeeqb.qlb
```

The above command line will load QuickBASIC and the user library.

---

#### Program (fastscan.bas)

```
CALL Initialize(21, 0) ' Init as system controller
'--- Setup 2001 measurement mode
DIM k2001data AS STRING * 1500

CLS
CALL SEND(16, "*RST", GPIB.STATUS%) ' Reset 2002
SLEEP 2

'format readings
CALL SEND(16, ":form:elem read", GPIB.STATUS%) ' Return readings only

'dcv config CALL SEND(16, ":sens:func 'VOLT:DC'", GPIB.STATUS%) ' Select DCV function
CALL SEND(16, ":sens:volt:dc:nplc .01", GPIB.STATUS%) ' Select 0.01 plc reading rate
CALL SEND(16, ":sens:volt:dc:rang 2", GPIB.STATUS%) ' Select 2V range

'configure scan
CALL SEND(16, ":rout:scan:int (@5,10)", GPIB.STATUS%) ' Scan list = chans 5 & 10

'config trig
CALL SEND(16, ":init:cont off; :abor", GPIB.STATUS%) ' Disable continuous initiation
' and place 2002 in idle

CALL SEND(16, ":arm:lay1:sour bus", GPIB.STATUS%) ' Set layer 1 to bus source
CALL SEND(16, ":arm:lay2:sour imm", GPIB.STATUS%) ' Set layer 2 to immediate source
CALL SEND(16, ":trig:sour imm; coun inf", GPIB.STATUS%) ' Set trigger layer to immediate
' source and infinite count
CALL SEND(16, ":init:cont on", GPIB.STATUS%) ' Take 2002 out of idle
```

**Program (fastscan.bas) (cont.)**

```
'config buffer
 ALL SEND(16, ":trac:cle; poin 1810; egr comp; feed sens", GPIB.STATUS%)
 ' Clear readings from buffer
 ' Set buffer size to 1810 points
 ' Select COMPACT element group
 ' Select SENSE as source of readings

 CALL SEND(16, ":trac:feed:cont next", GPIB.STATUS%)
 ' Select the NEXT buffer control
 ' mode

'Trigger 2002
 SLEEP 1
 CALL TRANSMIT("UNL UNT LISTEN 16 GET", STATUS%)
 ' Start scan

'wait for buffer to fill
 PRINT "Collecting Data....."
 SLEEP 15

'get data
 CALL SEND(16, ":trac:data?", STATUS%)
 ' Read buffer
 CALL Enter(k2002data$, Gpib.len%, 16, GPIB.STATUS%)
 PRINT "DCV = "; k2002data$
END
```

## Measure High Speed Channels; Model 2001-SCAN

### Microsoft QuickBASIC 4.5 Keithley KPC-488.2 Interface

©1992, Keithley Instruments, Inc.

#### Description

This program measures (DCV) the two high speed channels (ch 5 and 10) of the Model 2001-SCAN Scanner Card. Each channel is measured five times for a total of 10 measurements. The DCV reading and the elapsed time for each measurement are displayed on the computer CRT.

#### Required equipment

- Model 2002 Multimeter

- Model 2001-SCAN Scanner Card (installed in the Model 2002)
- Microsoft QuickBASIC 4.5
- Any one of the following IEEE-488 interfaces:
  - Keithley Model KPC-488.2
  - Keithley Model KPC-488.2AT
  - Capital Equipment Corporation PC<>488

The program assumes that the Model 2002 is set to address 16.

#### Loading user library

The user library for QuickBASIC 4.5 is provided with the IEEE-488 interface (ieeeqb.qlb). Assuming QuickBASIC and the user library are in the same DOS directory, enter the following command line from the DOS prompt:

```
QB /L ieeeqb.qlb
```

The above command line will load QuickBASIC and the user library.

---

#### Program (scan2001.bas)

```
'$INCLUDE: 'ieeeqb.bi'
CLS
CALL initialize(21, 0)
DIM k2002data AS STRING * 20

CALL send(16, "*RST; :init:cont off; :abor", gpib.status%)

CALL send(16, ":trig:sour bus; coun 10", gpib.status%)

CALL send(16, ":sens:func 'Volt:DC'", gpib.status%)
CALL send(16, ":sens:volt:dc:nplc .01", gpib.status%)
CALL send(16, ":form:elem read,chan", gpib.status%)

CALL send(16, ":sens:volt:dc:aver:stat 0", gpib.status%)
CALL send(16, ":init:cont on", gpib.status%)
```

' Disable continuous initiation  
' and put 2002 in idle.  
  
' Set trigger layer source to BUS  
' and count to 10.  
  
' Select DCV function  
  
' Set reading rate to 0.01 nplc  
  
' Include reading and channel  
' number in data string  
  
' Disable filter  
' Take 2002 out of idle

**Program (scan2001.bas)**

```
FOR x = 1 TO 5
 T1 = TIMER
 CALL send(16, ":rout:clos (@5)", gpib.status%) ' Close channel 5
 CALL transmit("UNL UNT LISTEN 16 GET", gpib.status%) ' Trigger a measurement
 ' Fetch reading
 CALL send(16, "fetch?", gpib.status%)
 CALL enter(k2002data$, gpib.len%, 16, gpib.status%)
 PRINT "DCV="; k2002data$ ' Display reading
 T2 = TIMER
 T3 = T2 - T1
 PRINT "It took "; T3; " seconds"

 CALL send(16, ":rout:clos (@10)", gpib.status%) ' Close channel 10
 CALL transmit("UNL UNT LISTEN 16 GET", gpib.status%) ' Trigger a measurement
 ' Fetch reading
 CALL send(16, "fetch?", gpib.status%)
 CALL enter(k2002data$, gpib.len%, 16, gpib.status%)
 PRINT "DCV="; k2002data$= ' Display reading
 T2 = TIMER
 T3 = T2 - T1
 PRINT "It took "; T3; " seconds"

 ' Display time it took to take
 ' reading
NEXT x
END
```



## Scan Two Channels; Model 2001-SCAN

### Microsoft QuickBASIC 4.5 Keithley KPC-488.2 Interface

©1992, Keithley Instruments, Inc.

#### Description

This program scans and measures two channels of the Model 2001-SCAN Scanner Card. Channel 2 is configured for  $\Omega$ 2 measurements and channel 4 is configured for RTD temperature measurements. The scan is performed five times for a total of 10 measurements. The 10 readings are displayed on the computer CRT.

#### Required equipment

- Model 2002 Multimeter
- Model 2001-SCAN Scanner Card (installed in the Model 2002)

- RTD Temperature Sensor (connected to channel 4 of the scanner card)
- Microsoft QuickBASIC 4.5
- Any one of the following IEEE-488 interfaces:
  - Keithley Model KPC-488.2
  - Keithley Model KPC-488.2AT
  - Capital Equipment Corporation PC<>488

The program assumes that the Model 2002 is set to address 16.

#### Loading user library

The user library for QuickBASIC 4.5 is provided with the IEEE-488 interface (ieeeqb qlb). Assuming QuickBASIC and the user library are in the same DOS directory, enter the following command line from the DOS prompt:

```
QB /L ieeeqb.qlb
```

The above command line will load QuickBASIC and the user library.

---

#### Program (2001scrd.bas)

```
CLS
FOR I = 1 TO 5
 CALL SEND (16, ":form:elem read", GPIB.STATUS%)
 CALL SEND (16, ":sens:func 'RES'", GPIB.STATUS%)
 CALL SEND (16, ":rout:clos (@2)", GPIB.STATUS%)
 CALL SEND (16, ":fetch?", GPIB.STATUS%)
 CALL Enter(k2002data$, Gpib.len%, 16, GPIB.STATUS%)
 PRINT "RES = "; k2002data$
 CALL SEND (16, ":sens:func 'TEMP'", GPIB.STATUS%)
 CALL SEND (16, ":rout:clos (@4)", GPIB.STATUS%)
 CALL SEND (16, ":fetch?", GPIB.STATUS%)
 CALL Enter(k2002data$, Gpib.len%, 16, GPIB.STATUS%)
 PRINT "TEMP = "; k2002data$
NEXT I
END
```

' Include only the readings  
' in the data string  
' Select the ohms function  
' Close channel 2  
' Fetch reading  
' Print reading  
' Select the temperature  
' function  
' Close channel 4  
' Fetch reading  
' Display reading

## Scan Thermocouple Card; Model 7014

### Microsoft QuickBASIC 4.5 Keithley KPC-488.2 Interface

©1992, Keithley Instruments, Inc.

#### Description

This program scans and measures five channels of the Model 7014 Thermocouple Multiplexer Card. Channels 2 and 3 are configured for Type K TC temperature measurements using channel 1 as the reference junction. Channels 4 and 5 are configured for DCV measurements on the 2V range. Seven scans are performed for a total of 35 measurements.

After all 35 readings are stored in the buffer, they are dumped out over the bus to the computer where each reading is displayed. Also displayed on the computer CRT is the total processing time (in seconds) for the 35 readings and the average time for each reading.

#### Required equipment

- Model 2002 Multimeter
- Model 7001 or 7002 Switch System

- Model 8501-1 Trigger Link Cable (connect 2002 to 7001 or 7002)
- Model 7014 Thermocouple Multiplexer Card (installed in slot 1 of 7001 or 7002)
- Two Type K Thermocouples (connected to channels 2 and 3 of 7014)
- Microsoft QuickBASIC 4.5
- Any one of the following IEEE-488 interfaces:
  - Keithley Model KPC-488.2
  - Keithley Model KPC-488.2AT
  - Capital Equipment Corporation PC<>488

The program assumes that the Model 2002 is set to address 16, and the address of the switch system (Model 7001 or 7002) is set to 7.

#### Loading user library

The user library for QuickBASIC 4.5 is provided with the IEEE-488 interface (ieeeqb.qlb). Assuming QuickBASIC and the user library are in the same DOS directory, enter the following command line from the DOS prompt:

```
QB /L ieeeqb.qlb
```

The above command line will load QuickBASIC and the user library.

---

#### Program (bufclint.bas)

```
'$INCLUDE: 'IEEEQB.BI'
'
' Initialize global variables.
'
CLS
DmmAddr% = 16
ScanAddr% = 7
Rdg$ = SPACE$(200)
cmd$ = SPACE$(80)
Sme$ = SPACE$(10)
'
'
' Initialize GPIB.
'
CALL initialize(21, 0)
CALL setoutputEOS(10, 0)
CALL setinputEOS(10)
CALL settimeout(5000)

cmd$ = "*CLS"
GOSUB send2002 ' Clear 2002
cmd$ = "*CLS"
GOSUB send7001 ' Clear 7001
```

**Program (bufclint.bas) (cont.)**

```

' Idle 2002 and 7001.
,
cmd$ = "*RST; :init:cont off"
GOSUB send2002 ' Reset 2002 and disable continuous
 ' initiation

cmd$ = ":abor"
GOSUB send2002 ' Place 2002 in idle

cmd$ = "*RST; :init:cont off"
GOSUB send7001 ' Reset 7001 and disable continuous
 ' initiation

cmd$ = ":abor"
GOSUB send7001 ' Place 7001 in idle

,
' Initialize 2002.
' cmd$ = ":syst:azer:stat on"
GOSUB send2002 ' Enable auto zero
cmd$ = ":form:elem read"
GOSUB send2002 ' Use only the reading in the data
 ' string

cmd$ = ":sens:volt:dc:nplc .01"
GOSUB send2002 ' Set DCV reading rate for 0.01 nplc
cmd$ = ":sens:volt:dc:rang 1"
GOSUB send2002 ' Select 2V range
cmd$ = ":sens:func 'temp'"
GOSUB send2002 ' Select TEMP function
cmd$ = ":sens:temp:aver:stat off"
GOSUB send2002 ' Disable filter
cmd$ = ":sens:temp:nplc .01"
GOSUB send2002 ' Set TEMP reading rate for 0.01 nplc
cmd$ = ":rout:scan:ext:func (@1),'rjun1'"
GOSUB send2002 ' Assign RJUN1 to external channel 1
cmd$ = ":rout:scan:ext:func (@2,3),'temp'"
GOSUB send2002 ' Assign TEMP to channels 2 and 3
cmd$ = ":rout:scan:ext:func (@4,5),'volt:dc'"
GOSUB send2002 ' Assign DCV to channels 4 and 5
cmd$ = ":rout:scan:ext (@1:5)"
GOSUB send2002 ' External scan list = chans 1 thru 5

'Set up TC parameters

cmd$ = ":temp:tran tc"
GOSUB send2002 ' Select TC transducer type
cmd$ = ":temp:tc:type k"
GOSUB send2002 ' Specify K type TC transducer
cmd$ = ":temp:rjun1:rrel real"
GOSUB send2002 ' Select REAL reference type
cmd$ = ":rout:clos (@1!1)"
GOSUB send7001 ' Close channel 1!1
cmd$ = ":temp:rjun1:real:offs 0.05463"
GOSUB send2002 ' Set 0°C voltage offset to 0.05463V
cmd$ = ":temp:rjun1:real:tco .0002"
GOSUB send2002 ' Set temperature coefficient to 0.0002
cmd$ = ":temp:rjun1:acq"
GOSUB send2002 ' Update reference temperature SLEEP 1
cmd$ = ":rout:open (@1!1)"
GOSUB send7001 ' Open channel 1!1
cmd$ = ":arm:lay1:sour imm"
GOSUB send2002 ' Set arm layer 1 source to Immediate
cmd$ = ":arm:lay2:sour imm"
GOSUB send2002 ' Set arm layer 2 source to Immediate
cmd$ = ":trig:sour tlin"
GOSUB send2002 ' Set trigger layer source to Triglink

```

**Program (bufclint.bas) (cont.)**

```

cmd$ = ":trig:tcon:asyn:ilin 2; olin 1"
GOSUB send2002 ' Select Triglink lines; input = line
 ' #2, output = line #1

cmd$ = "trig:tcon:dir sour"
GOSUB send2002 ' Enable source bypass for trigger
 ' layer

cmd$ = ":arm:lay1:coun 1"
GOSUB send2002 ' Set arm layer 1 count to 1
cmd$ = ":arm:lay2:coun 1"
GOSUB send2002 ' Set arm layer 2 count to 1
cmd$ = ":trig:coun 35"
GOSUB send2002 ' Set trigger layer count to 35
cmd$ = ":arm:lay2:del 0"
GOSUB send2002 ' Set arm layer 2 delay to zero
cmd$ = ":trig:del 0"
GOSUB send2002 ' Set trigger layer delay to zero

' Initialize 7001.
cmd$ = ":rout:open all"
GOSUB send7001 ' Open all channels
cmd$ = ":rout:scan (@1!1:1!5)"
GOSUB send7001 ' Scan list = chans 1!1 thru 1!5
cmd$ = ":arm:lay1:sour imm"
GOSUB send7001 ' Set arm layer 1 source to Immediate
cmd$ = ":arm:lay2:sour imm"
GOSUB send7001 ' Set arm layer 2 source to Immediate
cmd$ = ":trig:sour tlin"
GOSUB send7001 ' Set trigger layer source to Triglink
cmd$ = ":trig:tcon:asyn:ilin 1; olin 2"
GOSUB send7001 ' Select Triglink lines; input = line
 ' #1, output = line #2

cmd$ = ":arm:lay1:coun 1"
GOSUB send7001 ' Set arm layer 1 count to 1
cmd$ = ":arm:lay2:coun 1"
GOSUB send7001 ' Set arm layer 2 count to 1
cmd$ = ":trig:coun 35"
GOSUB send7001 ' Set trigger layer count to 35
cmd$ = ":arm:lay2:del 0"
GOSUB send7001 ' Set arm layer 2 delay to zero
cmd$ = ":trig:del 0"
GOSUB send7001 ' Set trigger layer delay to zero
cmd$ = ":trig:tcon:dir sour"
GOSUB send7001 ' Enable source bypass of trigger
 ' layer

' Arm buffer.
cmd$ = "*SRE 1"
GOSUB send2002 ' Set MSB bit of SRE register
cmd$ = "stat:meas:ptr 32767; ntr 0; enab 512"
GOSUB send2002 ' Set all PTR bits and clear all NTR
 ' bits for measurement events
 ' Set Buffer Full bit of Measurement
 ' Event Enable Register

cmd$ = ":trac:feed calc"
GOSUB send2002 ' Select Calculate as reading source
cmd$ = ":trac:poin 35"
GOSUB send2002 ' Set buffer size to 35 points
cmd$ = ":trac:egr full"
GOSUB send2002 ' Select Full element group
cmd$ = ":form:data sre"
GOSUB send2002 ' Select IEEE754 single precision data
 ' format

```

**Program (bufclint.bas) (cont.)**

```

cmd$ = ":trac:feed:cont next; *OPC"
GOSUB send2002 ' Select Next buffer control mode
 ' Set OPC upon completion of commands

cmd$ = ":rout:scan:lssel ext"
GOSUB send2002 ' Select external scan mode

'trigger equipment
cmd$ = ":init"
GOSUB send7001 ' Take 7001 out of idle
cmd$ = ":init"
GOSUB send2002 ' Take 2002 out of idle

'
' Start filling....
'
t1 = TIMER
' Wait for buffer to fill...
'
DO
 DO
 LOOP UNTIL srq%
 CALL spoll(DmmAddr%, poll%, status%)
 LOOP UNTIL (poll% AND 64) ' Loop until buffer fills
 cmd$ = ":stat:meas:even?"
 GOSUB send2002
 CALL enter(Sme$, length%, 16, status%)

'
' Go get buffer contents.
'
cmd$ = "trac:data?"
GOSUB send2002 ' Read all readings in buffer
DIM Readings!(1 TO 350), dummy!(1 TO 1)
' Setup CEC for LISTEN & 2002 for TALK
CALL transmit("UNT UNL MLA TALK 16", status%)
' Read 2 bytes (#0)
r$ = SPACE$(2)
CALL receive(r$, 1%, status%)

NumDataPoints% = 35
' Get Data in 4 blocks since CEC can only handle up to 64kB
' per data transfer.
NumBytes% = NumDataPoints% * 4
CALL rarray(Readings!(1), NumBytes%, 1%, status%)
' get Terminator Character(s)
CALL settimeout(100)
CALL rarray(dummy!(1), 1, 1%, status%)
CALL settimeout(10000)
CALL transmit("UNT UNL", status%) ' UNTalk and UNListen all devices
t2 = TIMER
t3 = t2 - t1
FOR i = 1 TO 35
PRINT "Rdg("; i; ") = "; Readings!(i) ' Display reading
NEXT i
PRINT
PRINT "Total time = "; t3 ' Display total processing time
 ' for all readings

PRINT
t4 = t3 / 35
PRINT "Seconds per channel = "; t4 ' Display the average time for each
 ' reading

END

```

---

**Program (bufclint.bas) (cont.)**

```
send2002:
 CALL send(DmmAddr%, cmd$, status%)

RETURN

send7001:
 CALL send(ScanAddr%, cmd$, status%)
RETURN
```

# H

## HP3458A Emulation Mode

---

### Introduction

This appendix provides detailed information on using the Model 2002 HP3458A emulation mode. The emulation mode gives the Model 2002 a high degree of compatibility with the Hewlett-Packard HP3458A Digital Multimeter, allowing the instrument to be substituted for an HP3458A in an existing measurement system with little or no program modifications.

### Firmware revision level

The HP3458A emulation mode is available in Model 2002s equipped with revision A05 and later main processor firmware. The firmware revision level is displayed during the power-up cycle and may be displayed at any time by using the GENERAL/ SERIAL # selection in the main MENU.

### Enabling the HP3458A emulation mode

The HP3458A emulation mode may be enabled from the front panel by using the LANGUAGE selection in the GPIB menu as follows:

1. Press the MENU key to display the main menu.
2. Select GPIB, then press ENTER.
3. Select LANGUAGE, then press ENTER.
4. Choose HP3458-EMULATION, then press ENTER.
5. Enable or disable the emulation mode as desired, then press ENTER to complete your selection.
6. Press EXIT as required to return to normal display.

### Unsupported commands

Table H-1 summarizes commands not supported by the Model 2002 HP3458A emulation mode.

**Table H-1**

Commands not supported by HP3458A emulation mode

ACAL	ACBAND**	AUXERR?	BEEP* <sup>5</sup>	CAL
CALL	CALNUM?	CALSTR <sup>1</sup>	COMPRESS**	CONT
DEFEAT* <sup>5</sup>	DEFKEY**	DELSUB**	DIAGNOST	DSAC**
DSDC**	END* <sup>2</sup>	EXTOUT	FIXEDZ <sup>5</sup>	INBUF <sup>5</sup>
ISCALE?	LEVEL	LFILTER <sup>5</sup>	LFREQ	MATH <sup>5</sup>
MENU*	MMATH <sup>5</sup>	PAUSE	PURGE**	QFORMAT* <sup>3</sup>
RATIO <sup>4,5</sup>	RES	RMATH	SCAL	SCRATCH**
SECURE	SLOPE	SMATH	SSAC**	SSDC**
SSPARM?	SSRC	SUB	SUBEND	TBUFF* <sup>5</sup>
TEST	TONE*			

\* Non-fatal commands. All other commands will result in fatal errors except as noted below.

\*\*These commands will not be accepted and will generate a syntax error if any parameter is sent. Otherwise, they will return a "Function not supported" error.

<sup>1</sup> CALSTR? query is supported and returns the calibration date.

<sup>2</sup> END ALWAYS or END 2 will be accepted but does nothing because END ALWAYS is the normal state of the Model 2002.

<sup>3</sup> QFORMAT 0 or QFORMAT NUM will be accepted as a no-op. QFORMAT? always returns a -1.

<sup>4</sup> RATIO? returns a 0 for compatibility.

<sup>5</sup> The following commands will be accepted but do nothing because they are the normal state of the Model 2002:

BEEP OR BEEP OFF	INBUF or INBUF OFF	MMATH or MMATH OFF
DEFEAT or DEFEAT OFF	LFILTER or LFILTER OFF	RATIO or RATIO OFF
FIXEDZ or FIXEDZ OFF	MATH or MATH OFF	TBUFF or TBUFF OFF

## Command syntax and compatibility

The following paragraphs discuss certain command syntax and compatibility issues that apply to the HP3458A emulation mode.

### Parameter defaults

The Model 2002 will assume default parameters if the parameters are omitted. Default parameters assigned a value of -1. Sequential commas or omission of the first parameter, however, are not supported.

Examples: FUNC	Supported
FUNC ACV	Supported
FUNC ACV,-1,-1	Not Supported
FUNC, , AUTO	Not Supported
FUNC ACV,,	Not Supported

### Delimiting parameters

The Model 2002 supports an undocumented feature of the HP3458A, which allows parameters to be separated by either spaces or commas.

Examples: RANGE AUTO 2  
 FUNC OHMF 200 0.03  
 FUNC ACI 750, 10

### Function command short forms

The HP3458A emulation mode supports the short forms of the following FUNC commands:

DCV	DCI
ACV	ACI
ACDCV	ACDCI
OHM	OHMF

The short forms of these commands are essentially the same as sending the FUNC command, but with FUNC omitted.

Examples:	Standard Form	Short Form
	FUNC ACI, 0.01, 10	ACI, 0.01, 10
	FUNC OHM 2000	OHM 2000



**Unsupported queries**

If an unsupported query is detected, a -1 will be returned as the query response in most cases. These are queries supported by the HP3458A but not supported by the Model 2002. FIXED2 and EXTOUT will not return -1, however.

Sending the query form of commands not supported by the HP3458A will result in an error.

**Query format**

The query format (set by the QFORMAT command) will always be set to NUM.

**Error checking**

The following commands pertain to HP3458A emulation mode error checking:

- EERR ON|OFF Enable/disable emulation mode error checking.
- EERR? Query current state of emulation mode error checking.

If EERR is ON, an error message will appear on the front panel, as well as in the error queue, and bit 14 in the error register will be set when an error occurs. To generate an SRQ when an emulation mode error is detected, set EMASK to 16384 and RQS to 32.

**Supported HP3458A commands**

Table H-2 summarizes commands supported by the HP3458A emulation mode. Each command is described in detail in subsequent paragraphs.

**Table H-2**  
*Supported HP3458A commands*

Command	Description
APER	Aperture
ARANGE	Range
AZERO	Autozero
CALSTR?	Request calibration date
CSB	Clear status register
DELAY	Trigger/sample time interval
DISP	Display mode and message
EMASK	Error conditions
ERR?	Request error register
ERRSTR?	Request error number and string
FREQ	Frequency function
FSOURCE	Frequency/period signal source
FUNC	Measurement function and range
ID?	Request unit identification
LINE?	Request power line frequency
MCOUNT?	Request number of readings stored in memory
MEM	Memory storage
MFORMAT	Reading format
MSIZE?	Request memory size
NDIG	Number of display digits
NPLC	A/D integration time in line cycles
NRDGS	Readings per trigger, event
OCOMP	Offset-compensated ohms
OFORMAT	Reading format
OPT?	Request installed options
PER	Period measurement function
PRESET	Instrument configurations
RANGE	Measurement range
RESET	Power-on state
REV?	Request firmware revision levels
RMEM?	Request number of readings in memory
RQS	Status register bits
RSTATE	Recall instrument configuration
SETACV	ACV mode
SRQ	Enable SRQ
SSTATE	Save instrument configuration
STB?	Request status register value
SWEEP	Interval, samples per trigger
T or TRIG	Trigger event
TARM	Trigger arm event
TEMP?	Request internal temperature
TERM?	Request INPUTS switch status
TIMER	Timer interval

## APER

<b>Purpose</b>	To program the A/D integration time.	
<b>Format</b>	APER <aperture>	
<b>Parameter</b>	<aperture> = 166.67E-6s to 1s	
<b>Default</b>	1.67E-4s	
<b>Query</b>	APER?	Returns aperture in seconds.
<b>Description</b>	The APER command programs the Model 2002 A/D integration period. The unit will accept values between 0s and 1s, but it rounds values to meet the Model 2002's valid parameter range.	
<b>Example</b>	APER 1E-3	Program 1ms aperture.

## ARANGE

<b>Purpose</b>	To enable/disable the autorange mode.		
<b>Format</b>	ARANGE <range>		
<b>Parameter</b>	<range>		
	<b>&lt;range&gt; Parameter</b>	<b>Numeric Equivalent</b>	<b>Description</b>
	OFF	0	Disable autorange.
	ON	1	Enable autorange.
	ONCE	2	Autorange next reading.
<b>Default</b>	OFF		
<b>Query</b>	ARANGE?	Returns autorange status.	
<b>Description</b>	ARANGE enables/disables autorange mode. The valid parameters are OFF, ON, and ONCE, which correspond numerically to 0, 1, and 2 respectively.		
<b>Purpose</b>	Autorange can also be controlled by the FUNC and RANGE commands. Specifying AUTO for the second parameter of the FUNC command turns autoranging ON. Specifying AUTO for the first parameter of the RANGE command turns autoranging ON.		
<b>Example</b>	ARANGE ON	Enable autorange.	
	ARANGE 0	Disable autorange.	

## AZERO

<b>Purpose</b>	To enable/disable the autozero mode.	
<b>Format</b>	AZERO <mode>	
<b>Parameter</b>	<mode>	

<b>&lt;mode&gt; Parameter</b>	<b>Numeric Equivalent</b>	<b>Description</b>
OFF	0	Disable autozero.
ON	1	Enable autozero.
ONCE	2	Not supported (ignored).

**Default** ON

**Query** AZERO? Returns autozero status.

**Description** AZERO enables/disables the autozero mode. The valid parameters are OFF, ON, and ONCE, which correspond numerically to 0, 1, and 2 respectively. Note that the Model 2002 does not support the ONCE parameter; if this parameter is sent, it is ignored, and no mode change is executed. The Model 2002 autozeroing, synchronous mode is used when autozero is enabled.

The Model 2002 must be in the idle state for this command to work. (Trigger HOLD, trigger SYN.)

**Example** AZERO ON Enable autozero.

## CALSTR?

**Purpose** To request the calibration date.

**Format** CALSTR?

**Response** mmm-dd-19yy (month, date, year)

**Description** The CALSTR? query requests the calibration date from the instrument, which returns the information as a string in month, date, year format.

The Model 2002 does not support the associated CALSTR command.

## CSB

**Purpose** To clear status register bits.

**Format** CSB

**Parameter** None

**Description** The CSB command clears all bits in the status register, including bit 6 (SRQ).

## DELAY

**Purpose** To program the time interval between the trigger and sample events.

**Format** DELAY <time>

**Parameter** <time> = 1E-7s to 6000s

**Default** 0s

**Query** DELAY? Returns delay time in seconds.

**Description** The DELAY command programs the time interval between the trigger event and the first sample event in seconds. Although the valid parameter range is from 1E-7s to 6000s, the Model 2002 rounds any value below 1ms (0.001s) to 1ms. Specifying a delay of 0 selects the minimum delay time possible.

**Example** DELAY 50E-3 Program 50ms delay.

## DISP

**Purpose** To enable/disable the front panel display, to clear the display, and to send a message to the display.

**Format** DISP <control>, "<message>"

**Parameter** <control>

<control> Parameter	Numeric equivalent	Description
OFF	0	Display off or message.
ON	1	Normal operation.
MSG	2	Display message.
CLR	3	Clear display.

<message> Up to 52-character string enclosed in double quotes.

**Default** ON

**Query** DISP? Returns present value of <control> parameter.

**Description** The DISP command enables/disables the multimeter's display and may be used to send a message to the display, or to clear the display. ON selects normal operation. OFF displays a message if a valid message parameter has been sent; otherwise, all dashes are displayed. Readings are no longer displayed, and the display is not updated, except to service front panel keystrokes. The MSG parameter simply displays a message on the front panel, and the CLR parameter clears the display entirely. The <message> parameter is any string up to 52 characters enclosed in double quotation marks.

**Example**

DISP OFF	Turn off display.
DISP ON	Enable normal display operation.
DISP MSG, "Model 2002"	Display message.

## EMASK

**Purpose** To enable certain error conditions to set the error bit in the status register.

**Format** EMASK <bit\_value>

**Parameter** <bit\_value>

Decimal <bit_value>	Bit number	Error condition
1	0	Hardware error
4	2	Trigger too fast error
8	3	Syntax error
16	4	Command not allowed from remote
32	5	Undefined parameter received
64	6	Parameter out of range
2048	11	Settings conflict
16384	14	Function not supported

**Default** 32767

**Query** EMASK? Returns the weighted decimal sum of all enabled error conditions.

**Description** The EMASK command enables certain error conditions to set the error bit in the status register. Note that the <bit\_value> parameter is sent as a decimal-weighted value, and multiple error conditions may be enabled by adding up the weighted values of all bits to be set.

Bits 1, 7-10, 12, and 13 are used in the HP3458A but are not supported by the Model 2002.

**Note** Unlike the HP3458A, a masked-out error will not appear on the front panel display. If the <bit\_value> = 0, errors returned by ERR? will not be reported.

**Example**

EMASK 2	Enable trigger too fast error.
EMASK 9	Enable hardware and syntax errors.
EMASK 2048	Enable settings conflict error.

## ERR?

**Purpose** To request the error register value.

**Format** ERR?

Response	Decimal value	Bit number	Error condition
	1	0	Hardware error
	4	2	Trigger too fast error
	8	3	Syntax error
	16	4	Command not allowed from remote
	32	5	Undefined parameter received
	64	6	Parameter out of range
	2048	11	Settings conflict
	16384	14	Function not supported

**Description** The ERR? query returns the number representing all set bits in the error register. Sending this query and reading the response also clears the error register.

Bits 1, 7-10, 12, and 13 are used in the HP3458A but are not supported by the Model 2002.

**Note** If the EMASK <bit\_value> (above) is set to 0, errors will not be reported by ERR?.

## ERRSTR?

<b>Purpose</b>	To request the error number and error response string.
<b>Format</b>	ERRSTR?
<b>Response</b>	<error_number>, <error_string>
<b>Description</b>	<p>The ERRSTR? query returns two responses separated by a comma. The first response is the error number, and the second is the message explaining the error.</p> <p>Unlike the HP3458, Model 2002 errors are returned in the order generated instead of the error register bit order. No error register bits are cleared until the last error is read at which time all bits are cleared.</p>

## FREQ

<b>Purpose</b>	To select the frequency measurement function.	
<b>Format</b>	FREQ <max_input>, <%_resolution>	
<b>Parameter</b>	<max_input>	1V, 10V, or 100V
	<%_resolution>	Ignored
<b>Description</b>	The FREQ command selects the frequency measurement mode for the Model 2002. The first parameter selects a maximum input level of 1V, 10V, or 100V, while the second parameter is not supported by the Model 2002 and will be ignored.	
<b>Example</b>	FREQ	Select frequency.
	FREQ 10	Select frequency, 10V maximum input.

## FSOURCE

<b>Purpose</b>	To select the signal type for frequency or period measurements.																
<b>Format</b>	FSOURCE <source>																
<b>Parameter</b>	<source>																
	<b>&lt;source&gt; parameter</b>	<b>Numeric equivalent</b>															
	ACV	2															
	ACDCV	3															
	ACI	7															
	ACDCI	8															
<b>Description</b>	<table border="1"> <thead> <tr> <th>&lt;source&gt; parameter</th> <th>Numeric equivalent</th> <th>Description</th> </tr> </thead> <tbody> <tr> <td>ACV</td> <td>2</td> <td>AC voltage</td> </tr> <tr> <td>ACDCV</td> <td>3</td> <td>AC+DC voltage</td> </tr> <tr> <td>ACI</td> <td>7</td> <td>AC current</td> </tr> <tr> <td>ACDCI</td> <td>8</td> <td>AC+DC current</td> </tr> </tbody> </table>		<source> parameter	Numeric equivalent	Description	ACV	2	AC voltage	ACDCV	3	AC+DC voltage	ACI	7	AC current	ACDCI	8	AC+DC current
<source> parameter	Numeric equivalent	Description															
ACV	2	AC voltage															
ACDCV	3	AC+DC voltage															
ACI	7	AC current															
ACDCI	8	AC+DC current															
<b>Default</b>	ACV																
<b>Query</b>	FSOURCE?	Returns the present frequency source.															
<b>Description</b>	The FSOURCE command specifies the type of signal to be used as the input signal for frequency or period measurements. Signal types include AC voltage, AC current, AC+DC voltage, and AC+DC current.																

**Example**      FSOURCE ACV                      Select AC voltage source.  
                   FSOURCE ACDCI                Select AC+DC current source.

## FUNC

**Purpose**                      To select the measurement function and range.

**Format**                      FUNC <function> ,<max\_input>, <%\_resolution>

**Parameter**                <function>

<function> Parameter	Numeric Equivalent	Description
DCV	1	DC voltage
ACV	2	AC voltage
ACDCV	3	DC-coupled AC volts
OHM	4	2-wire resistance
OHMF	5	4-wire resistance
DCI	6	DC current
ACI	7	AC current
ACDCI	8	DC-coupled AC current
FREQ	9	Frequency
PER	10	Period
<max_input>		AUTO for autorange or full-range value
<%_resolution>		Ignored

**Default**                      DCV, AUTO

**Query**                      FUNC?                      Returns two responses separated by a comma: (1) the present measurement function, and (2) that function's present range.

**Description**                The FUNC command selects the type of measurement for the Model 2002. It also allows you to specify the measurement range for the respective function. (See paragraph 3.18 for details on ranges for the various measurement functions.) The <%\_resolution> parameter is not supported by the Model 2002 and will be ignored.

- Notes**
1. The FUNC header may be omitted when programming the function.
  2. All HP3458A functions not listed above are not supported by the Model 2002.

**Example**                      FUNC DCV                      Select DCV function.  
                   FUNC ACV, AUTO                Select ACV function, autorange.  
                   DCI, AUTO                      Select DCI function without using header.

## ID?

**Purpose**                      To request the instrument's identification string.

**Format**                      ID?

**Response**                HP3458A

**Description** The ID? query allows you to request the instrument's identification string. The multimeter responds with the string "HP3458A."

## LINE?

**Purpose** To request the AC power line frequency.

**Format** LINE?

**Response** Line frequency in Hz.

**Description** The LINE? query measures and returns the frequency of the AC power line. The returned value is in Hz, for example: 60.

## MCOUNT?

**Purpose** To request the number of readings presently stored in memory.

**Format** MCOUNT?

**Response** Number of readings

**Description** The MCOUNT? query requests the total number of readings currently stored in memory. The instrument returns the total number of stored readings in standard numeric form.

## MEM

**Purpose** To enable/disable reading memory, and to designate the storage mode.

**Format** MEM <mode>

**Parameter** <mode>

<mode> parameter	Numeric equivalent	Description
OFF	0	Stops storing readings, stored readings stay intact
LIFO	1	Clears previous readings, stores new readings as last in, first out
FIFO	2	Clears previous readings, stores new readings as first in, last out
CONT	3	Clears previous readings, and selects previous memory storage mode

**Default** FIFO (power-on = OFF)

**Query** MEM? Returns the present memory mode.

**Description** The MEM command enables or disables reading memory, and it also selects the storage mode. If there was no previous mode chosen for the CONT mode, FIFO is selected.



<b>Example</b>	MEM FIFO	Store as first in, last out.
	MEM OFF	Turn off storage.

## MFORMAT

**Purpose** To clear reading memory, and to designate the storage format for new readings.

**Format** MFORMAT <format>

**Parameter** <format>

<format> parameter	Numeric equivalent	Description
ASCII	1	ASCII
SREAL	4	Single real
DREAL	5	Double real

**Default** SREAL

**Query** MFORMAT? Returns the present setting of the memory format.

**Description** The MFORMAT command clears reading memory and designates the storage format for new readings. Available formats include ASCII, as well as single and double real.

Unlike the HP3458A, the Model 2002 MFORMAT command does affect the OFORMAT setting. These two commands perform identical functions.

<b>Example</b>	MFORMAT ASCII	Select ASCII format.
	MFORMAT DREAL	Select double real format.

## MSIZE?

**Purpose** To request reading memory size.

**Query** MSIZE? Returns two responses separated by a comma: (1) total memory size in bytes, and (2) the total amount of available memory in bytes.

**Description** The MSIZE? query is useful for determining total memory size and the number of memory bytes still available for storage.

## NDIG

**Purpose** To program the number of display digits used for readings.

**Format** NDIG <#\_digits>

**Parameter** <#\_digits> 3 to 8 (3-1/2 digits to 8-1/2 digits)

**Default** 7 (7-1/2 digits)

**Query** NDIG? Returns the currently specified number of display digits.

- Description** The NDIG command programs the number of digits the instrument uses when displaying readings. Note that there is an implied 1/2 digit, so when you specify n digits, n-1/2 are displayed.
- Note** The Model 2002 frequency function is limited to only 4 or 5 digits (NDIG 3 or NDIG4). Values greater than 4 will be set to 4 with the frequency function.
- Example**
- |        |                       |
|--------|-----------------------|
| NDIG 5 | Display 5-1/2 digits. |
| NDIG 8 | Display 8-1/2 digits. |

## NPLC

- Purpose** To program the A/D converter integration time in power line cycles.
- Format** NPLC <power\_line\_cycles>
- Parameter** <power\_line\_cycles> 0.01 to 50
- Default** 0.01
- Query** NPLC? Returns the currently specified integration time in power line cycles.
- Description** The NPLC command programs the A/D converter integration time in terms of power line cycles. The programmable range is from 0.01 to 100 power line cycles.
- A value of 100 PLC will be adjusted to 10 PLC. Other values above 50 PLC will be adjusted to 50 PLC.
- Example**
- |        |                                                |
|--------|------------------------------------------------|
| NPLC 1 | Program 1 power line cycle integration period. |
| NPLC 5 | Program 5 power line cycle integration period. |

## NRDGS

- Purpose** To program the number of readings per trigger and the trigger event.
- Format** NRDGS <count>, <event>
- Parameter** <count> # of readings (1 to 99999)  
<event>
- | <event> parameter | Numeric equivalent | Description                                                           |
|-------------------|--------------------|-----------------------------------------------------------------------|
| AUTO              | 1                  | Initiates readings continuously                                       |
| EXT               | 2                  | Initiates reading on negative transition on the external trigger line |
| TIMER             | 6                  | Same as AUTO with interval specified by TIMER command                 |
- Default** count = 1
- Query** NRDGS? Returns two responses separated by a comma: (1) the number of readings per trigger, and (2) the present trigger event.

**Description** The NRDGS command programs the number of readings per trigger as well as the event that initiates the trigger. Available events include continuous, external trigger, the GPIB talk command, as well as timer events.

All other HP3458A trigger events are not supported by the Model 2002.

**Example** NRDGS 10, SYN Take 10 readings per talk command.  
 NRDGS 100, EXT Take 100 readings per external trigger event.

## OCOMP

**Purpose** To enable or disable the offset-compensated ohms mode.

**Format** OCOMP <control>

**Parameter** <control>

<control> parameter	Numeric equivalent	Description
OFF	0	Offset-compensated ohms off
ON	1	Offset-compensated ohms on

**Default** ON (power-on default = OFF)

**Query** OCOMP? Returns the current offset-compensated ohms state.

**Description** The OCOMP command enables/disables the offset-compensated ohms function.

**Example** OCOMP ON Enable offset-compensated ohms.

## OFORMAT

**Purpose** To program the data format for both normal and memory readings.

**Format** OFORMAT <format>

**Parameter** <format>

<format> parameter	Numeric equivalent	Description
ASCII	1	ASCII
SREAL	4	Single real
DREAL	5	Double real

**Default** ASCII

**Query** OFORMAT? Returns the present setting of the output format.

**Description** The OFORMAT command controls the designated GPIB output format for readings transferred over the bus for both normal readings and readings from memory.

The OFORMAT command is identical to the MFORMAT command. Both commands control the format of both normal and memory readings.

**Example** OFORMAT ASCII      Select ASCII format.

## OPT?

**Purpose** To request a report of installed options.

**Format** OPT?

**Response**  
 0                      No installed options  
 1                      MEM1 or MEM2 extended memory option installed

**Description** The OPT? query requests a report of installed options. The response is a numeric value that indicates whether or not a memory option is installed.

## PER

**Purpose** To select the period measurement function.

**Format** PER <max\_input>, <%\_resolution>

**Parameter** <max\_input>, <%\_resolution>                      Ignored

**Description** The PER command selects the period function as the measurement mode for the Model 2002. Both parameters are ignored as the Model 2002 uses only autoranging for period measurements.

The front panel does not display period measurements.

**Example** PER                      Select period function.

## PRESET

**Format** PRESET <type>

**Parameter** <type>                      NORM, FAST, or DIG

### NORM

---

AZERO ON	NDIG 6
DCV AUTO	NPLC 1
DISP ON	NRDGS 1,AUTO
FSOURCE ACV	OCOMP OFF
TARM AUTO	TIMER 1
TRIG SYN	

**FAST**

---

Same as NORM with the following exceptions:

DCV 10            OFORMAT DINT  
 DISP OFF        TRIG AUTO  
 AZERO OFF

**DIG:** Not supported.

<b>Default</b>	NORM
<b>Description</b>	The PRESET command selects one of two preset instrument configurations, one for normal operation, and one for fast operation. The DIG preset configuration supported by the HP3458A is not supported by the Model 2002.
<b>Example</b>	PRESET FAST      Select fast configuration.

**RANGE**

<b>Purpose</b>	To select the measurement range.
<b>Format</b>	RANGE <max_input> ,<%_resolution>
<b>Parameter</b>	<max_input>      Manual range or AUTO (autorange) <%_resolution>   Ignored
<b>Default</b>	AUTO
<b>Query</b>	RANGE?          Returns the present measurement range for the current function.
<b>Description</b>	The RANGE command allows you to select a manual measurement range or autorange. (See paragraph 3.18 for range information specific to each function.) Specifying AUTO for the <max_input> parameter enables autoranging, and the <%_resolution> parameter is ignored.
<b>Example</b>	RANGE AUTO      Select autorange.

**RESET**

<b>Purpose</b>	To reset the Model 2002 to the power-on state.
<b>Format</b>	RESET
<b>Parameter</b>	None
<b>Description</b>	The RESET command resets the multimeter to the power-on state without cycling power. Reset effectively executes:

AZERO ON	DCV AUTO
DISP ON	EMASK 32767 (all errors enabled)
FSOURCE ACV	MEM OFF
MFORMAT SREAL	NDIG 7
NPLC 10	NRDGS 1,AUTO
OCOMP OFF	OFORMAT ASCII
TARM AUT	TIMER 1
TRIG AUTO	

All other commands and settings are unaffected.

## REV?

**Purpose** To request the main and front panel revision levels.

**Format** REV?

**Response** Main firmware revision/Front panel firmware revision

**Description** The REV? query allows you to request both the main processor firmware revision level, and the front panel display controller firmware revision level. The instrument returns two numbers separated by a slash: (1) the main processor firmware revision level, and (2) the front panel display controller firmware revision level.

The response form used by the Model 2002 is different from that of the HP3458A.

## RMEM?

**Purpose** To request readings stored in memory.

**Format** RMEM?

**Response** Reading #1, Reading #2, ... Reading #n

**Description** The RMEM? query returns all readings currently stored in memory. Note that the format of readings returned differs from that of the HP3458A. The Model 2002 returns all readings in one text block, separated by commas, with a string terminator only at the end of the block. The HP3458 includes a terminator between each reading. Also note that this command has been changed to a query-only format.

## RQS

**Purpose** To enable/disable status register bits that can cause an SRQ.

**Format** RQS <mask>

<b>Parameter</b>	<mask>		
	<b>Decimal weight</b>	<b>Bit number</b>	<b>Enabled condition</b>
	4	2	SRQ command executed
	8	3	Power-on SRQ
	32	5	Error (consult the error register)
	64	6	Service Requested (cannot disable this bit)
	128	7	Data available

**Default** 0

**Query** RQS? Returns the weighted sum of all enabled status register bits.

**Description** The RQS command enables one or more bits in the status register. When an enabled condition occurs, the SRQ line is asserted. All other conditions and bits are not supported, and thus are always 0. To enable multiple bits, add up the individual bit weights.

The SRQ command must be sent to enable SRQ.

**Example**  
RQS 32 SRQ on error.  
RQS 160 SRQ on error and data available.

## RSTATE

**Purpose** To recall an instrument configuration from memory.

**Format** RSTATE <state>

**Parameter** <state>

<b>Memory option</b>	<b>Valid &lt;state&gt; parameters</b>
No extended memory	SAV0
2002-MEM1 installed	SAV0-SAV4
2002-MEM2 installed	SAV0-SAV9

**Default** SAV0

**Description** The RSTATE command recalls a stored state from memory and configures the multimeter for that state. These states are saved by the SSTATE command. Note that the number of valid saved states depends on the amount of installed memory as indicated above.

**Example** RSTATE SAV0 Recall state 0.

## SETACV

**Purpose** To select the RMS conversion technique used for AC and AC+DC measurements.

**Format** SETACV <type>

**Parameter** <type>

<type> parameter	Numeric equivalent	Description
ANA	1	RMS conversion
RNDM	2	Low-frequency voltage measurements
SYNC	3	Low-frequency voltage measurements

**Default** ANA

**Query** SETACV? Returns the currently specified conversion technique. A “3” is returned for RNDM or SYNC.

**Description** The SETACV command selects the RMS conversion technique to be used for the AC or AC+DC voltage measurement modes. Note that both RNDM and SYNC choose the low-frequency voltage measurement mode.

**Example** SETACV SYNC Select low-frequency AC mode.

## SRQ

**Purpose** To enable SRQ.

**Format** SRQ

**Parameter** None

**Description** The SRQ command sets bit 2 in the Model 2002 status register. When bit 2 is enabled, the SRQ line will be asserted when certain conditions occur. (See RQS command.)

## SSTATE

**Purpose** To store the instrument's present configuration in memory.

**Format** SSTATE <state>

**Parameter** <state>

Memory option	Valid <state> parameters
No extended memory	SAV0
2002-MEM1 installed	SAV0-SAV4
2002-MEM2 installed	SAV0-SAV9

**Description** SSTATE stores the multimeter's present state in the given state memory location. Note that the number of available states depends on installed memory options as indicated above. Instrument states may be recalled with the RSTATE command.

**Example** SSTATE SAV0 Save state 0.



## STB?

**Purpose** To request the status register value.

**Format** STB?

Response	Decimal weight	Bit number	Status register condition
	4	2	SRQ command executed
	8	3	Power on
	16	4	Ready for instructions
	32	5	Error (as set by EMASK)
	64	6	Service requested (SRQ)
	128	7	Data available

**Description** The STB? query returns a number representing the weighted sum of all set bits in the status register.

The instrument may be programmed to generate an SRQ for specific status register conditions with the RQS command.

**Note** The STB? query will always show bit 4 as being cleared since the query is being processed, but this bit can be checked by using serial polling.

## SWEEP

**Purpose** To program the interval between readings and the number of samples per trigger.

**Format** SWEEP <effective\_interval>, <#\_samples>

**Parameter**

<effective_interval>	0.001 to 9999999.99
<#_samples>	1 to 99999

**Default** Interval: 0  
#samples: 1024 (power-on=1)

**Query** SWEEP? Returns two responses separated by a comma: (1) the specified interval, and (2) the specified number of samples.

**Description** The SWEEP command specifies the both the effective interval between readings (samples and the total number of samples taken per trigger event.

**Example** SWEEP 0.1, 100 0.1 interval, 100 samples.

## T or TRIG

**Purpose** To program the trigger event.

**Format** T <event>  
TRIG <event>

<b>Parameter</b>	<event>		
	<b>&lt;event&gt; parameter</b>	<b>Numeric equivalent</b>	<b>Description</b>
	AUTO	1	Triggers automatically
	EXT	2	Triggers on the negative edge of signal on external trigger connector
	SGL	3	Triggers once and reverts to HOLD
	HOLD	4	Disables triggering
<b>Default</b>	SGL (power-on = AUTO)		
<b>Query</b>	TRIG?	Returns the currently specified trigger event.	
<b>Description</b>	TRIG selects the trigger event. Only those events listed may be used; the remaining trigger events not listed are not supported by the Model 2002.		
<b>Example</b>	T EXT	Select external trigger.	
	TRIG SGL	Single trigger.	

## TARM

<b>Purpose</b>	To specify the event that arms the trigger event.		
<b>Format</b>	TARM <event>, <#_arms>		
<b>Parameter</b>	<event>		
	<b>&lt;event&gt; parameter</b>	<b>Numeric equivalent</b>	<b>Description</b>
	AUTO	1	Arms automatically
	EXT	2	Arms on the negative edge of signal on external trigger connector
	SGL	3	Arms once and reverts to HOLD
	HOLD	4	Disables arming
<b>Default</b>	AUTO		
<b>Query</b>	TARM?	Returns the currently selected arm event.	
<b>Description</b>	TARM defines the event that enables triggers. The number of arms can range from 1 to 99999, but HP3458A parameters (0 to 2.1E9) are accepted and modified as appropriate. The remaining arm events not listed are not supported by the Model 2002.		
<b>Example</b>	TARM EXT	Arm on external trigger.	

**TEMP?**

<b>Purpose</b>	To request the internal temperature of the Model 2002.
<b>Format</b>	TEMP?
<b>Response</b>	Model 2002 internal temperature in °C
<b>Description</b>	The TEMP? query returns the internal temperature of the Model 2002. The response is in standard numeric format in degrees Celsius.

**TERM**

<b>Purpose</b>	To request INPUTS switch status.
<b>Format</b>	TERM <source>
<b>Parameter</b>	<source>      Not used
<b>Query</b>	TERM?          Returns status of INPUTS switch (1= Front; 2=Rear)
<b>Description</b>	The TERM command is a no-op, and thus it is ignored. It is included for HP3458A compatibility. The TERM? query returns the status of the INPUTS switch as indicated above.

**TIMER**

<b>Purpose</b>	To define the timer sample interval.
<b>Format</b>	TIMER <time>
<b>Parameter</b>	<time>          0s to 6000s
<b>Default</b>	1s (power-on = 0s)
<b>Query</b>	TIMER?          Returns the currently specified time interval in seconds.
<b>Description</b>	The TIMER command defines the time interval in seconds for the TIMER sample event in the NRDGS command. The Model 2002 will accept time values from 0s to 6000s, but will modify values appropriately for compatibility.
<b>Example</b>	TIMER 2          Define 2 second sample interval.

# Index

## Symbols

\*CLS — clear status 3-29  
\*ESE <NRf> — event enable 3-30  
\*ESE? — event enable query 3-30  
\*ESR? — event status register query 3-31  
\*IDN? — identification query 3-32  
\*OPC — operation complete 3-33  
\*OPC? — operation complete query 3-34  
\*OPT? — option identification query 3-35  
\*RCL — recall 3-35  
\*RST — reset 3-36  
\*SAV — save 3-36  
\*SRE <NRf> — service request  
    enable 3-36  
\*SRE? — service request enable query 3-36  
\*STB? — status byte query 3-38  
\*TRG — trigger 3-39  
\*TST? — self-test query 3-39  
\*WAI — wait-to-continue 3-40  
:ABORt 3-152  
:ALternate[1] commands 3-91  
:AMETHod <name> 3-139  
:APERture <n> 3-93  
:AVERage commands 3-102  
:AZERo commands 3-138  
:CALCulate[1] 3-67  
:CALCulate2 3-69  
:CALCulate3 3-71  
:CLEar 3-145, 3-147  
:CLOSe <list> 3-86  
:CONDition? 3-134  
:COUNt <n> 3-153  
:COUPLing AC|DC 3-96  
:DATA? 3-151  
:DATA commands 3-92  
:DATE <yr>, <mo>, <day> 3-145  
:DElay <n> 3-153  
:DIGits <n> 3-101  
:DISPlay subsystem 3-76  
:DTCouple commands 3-114  
:EGRoup <name> 3-147  
:ENABle <NRf> 3-122  
:ERRor? 3-138  
:FEED <name> 3-148  
:FORMat subsystem 3-79  
:FREE? 3-147

:FRSWitch? 3-137  
:FUNctioN <name> 3-91  
:IMMediate 3-152  
:INITiate commands 3-152  
:INPut subsystem 3-84  
:KEY <NRf> 3-143  
:LFRequency 3-145  
:LSYNc:STATe <b> 3-143  
:METHod <name> 3-106  
:NPLCycles <n> 3-94  
:NTRansition <NRf> 3-132  
:OCOMPensated <b> 3-114  
:OPEN <list> 3-86  
:OPEN:ALL 3-87  
:OUTPut subsystem 3-85  
:POINts <n> 3-148  
:POSetup <name> 3-137  
:PRESet 3-134  
:PRESet 3-137  
:PTRansition <NRf> 3-125  
:PWINDow <n> 3-106  
:QUEue commands 3-135  
:REFerence <n> 3-99  
:RJJNctionX commands 3-112  
:RNUMber:RESet 3-146  
:ROUte subsystem 3-86  
:RTD commands 3-109  
:SCAN commands 3-87  
:SENSe2 subsystem 3-115  
:SIGNal 3-155  
:SOURce <name> 3-106, 3-154  
:SOURce subsystem 3-116  
:STATus subsystem 3-117  
:SYSTem subsystem 3-137  
:TCCouple:TYPE <name> 3-111  
:TIME <hr>, <min>, <sec> 3-145  
:TIMER <n> 3-154  
:TRACe subsystem 3-147  
:TRANSDUCer <name> 3-108  
:TSTamp commands 3-146  
:TSTamp:FORMat <name> 3-151  
:UNIT subsystem 3-159  
:VERSion? 3-138  
[:EVENTi]? 3-117  
[:FUNCTION] <name> 3-105  
[:SENSe[1]] subsystem 3-91

## A

ASCII character codes and IEEE-488 multi-line interface command messages C-1  
Auto filtering 2-73  
Autoranging 2-40

## B

Buffer 2-64  
Buffer multiple displays 2-70  
Burst mode 2-65

## C

Calculate multiple display 2-77  
Calculate subsystem 3-67  
CALIBRATION 2-96  
Common commands 3-29  
Condition registers 3-8  
Configuring data storage 2-67  
Configuring rel 2-41  
Configuring the arm layer 2-49  
Configuring the filters 2-74  
Configuring the scan layer 2-48  
Configuring the measure layer 2-46

## D

DC and AC current 2-23  
DC and AC voltage 2-9  
DCL (device clear) 3-5  
Display 2-4  
Display resolution 2-40

## E

Enable registers 3-8  
Enabling rel 2-41  
Error and status message 3-5  
Event registers 3-8  
Example programs G-1  
External triggering 2-50

## **F**

- Features 1-1
- Filter 2-71
- Filter modes 2-71
- Filter types 2-71
- Frequency 2-32
- Front panel aspects of IEEE-488 operation 3-5
- Front panel operation 2-1
- Front panel scanner controls 2-77
- Functions 2-9

## **G**

- GENERAL 2-99
- General bus commands 3-4
- General information 1-1
- GET (group executive trigger) 3-5
- GPIB 2-96
- GTL (go to local) 3-5

## **H**

- Halting triggers 2-50
- High energy circuit safety precautions 2-4
- HP3458A emulation mode H-1

## **I**

- IEEE-488 conformance information E-1
- IEEE-488 bus connections 3-1
- IEEE-488 bus overview D-1
- IEEE-488 primary address 2-4
- IEEE-488 reference 3-1
- IEEE-488 status indicators 3-5
- IFC (interface clear) 3-4
- Information messages 2-7
- Inspection 1-2
- Interface function codes B-1
- Introduction 1-1, 2-1, 3-1

## **L**

- LIMITS 2-97
- Line fuse replacement 2-2
- Line power connections 2-1
- LLO (local lockout) 3-4
- LOCAL key 3-6

## **M**

- Manual addenda 1-2
- Manual ranging 2-40
- Math 2-75
- Maximum readings 2-40
- Menu 2-87
- Multiple display of rel 2-41
- Multiple displays 2-4

## **N**

- Navigating menus 2-9

## **O**

- Options and accessories 1-2

## **P**

- Percent 2-76
- Percent deviation 2-76
- Polynomial 2-75
- Power-on default conditions 2-4
- Power-up 2-1
- Power-up sequence 2-2
- Primary address selection 3-2
- Programming syntax 3-23

## **Q**

- Queues 3-16
- QuickBASIC 4.5 programming 3-3

## **R**

- Range 2-40
- RANGe commands 3-96
- Relative 2-40
- REN (remote enable) 3-4
- Response time 2-73
- RTCLock commands 3-157

## **S**

- Safety symbols and terms 1-2
- SAVESETUP 2-90
- Scanner operation examples 2-83

- Scanning 2-77
- Scanning overview 2-77
- SCPI conformance information F-1
- SDC (selective device clear) 3-5
- Selecting and configuring math 2-76
- Sense subsystems 3-91
- Signal oriented measurement commands 3-41
- SPE, SPD (serial polling) 3-5
- Specifications 1-2, A-1
- Starting and stopping scanning 2-83
- Status and error messages 2-7
- Statusbyte and service request (SRQ) 3-16
- STATUS-MSG 2-99
- Status structure 3-6
- Storing and recalling readings 2-69

## **T**

- TCONfigure commands 3-155
- Temperature 2-33
- TEST 2-97
- THReshold commands 3-107
- Transition filters 3-8
- Trigger Link 2-53
- Trigger model 2-41
- Trigger model (IEEE-488 operation) 3-18
- Trigger subsystem 3-152
- Triggers 2-41
- Two and four-wire resistance 2-28

## **U**

- Using CHAN key to close and open internal channels 2-78
- Using CONFIGURECHAN to configure channels 2-79
- Using CONFIG-SCAN to configure scanning 2-80
- Using SCAN to configure scan parameters 2-81

## **W**

- Warm-up period 2-4
- Warranty information 1-2



Model No. \_\_\_\_\_ Serial No. \_\_\_\_\_ Date \_\_\_\_\_

Name and Telephone No. \_\_\_\_\_

Company \_\_\_\_\_

List all control settings, describe problem and check boxes that apply to problem. \_\_\_\_\_

Intermittent                       Analog output follows display                       Particular range or function bad; specify \_\_\_\_\_

IEEE failure                       Obvious problem on power-up                       Batteries and fuses are OK

Front panel operational                       All ranges or functions are bad                       Checked all cables

Display or output (check one)

Drifts                       Unable to zero  
 Unstable                       Will not read applied input

Overload

Calibration only                       Certificate of calibration required

Data required

(attach any additional sheets as necessary)

Show a block diagram of your measurement system including all instruments connected (whether power is turned on or not). Also, describe signal source.

Where is the measurement being performed? (factory, controlled laboratory, out-of-doors, etc.)

\_\_\_\_\_

What power line voltage is used? \_\_\_\_\_ Ambient temperature?°F \_\_\_\_\_

Relative humidity? \_\_\_\_\_ Other? \_\_\_\_\_

Any additional information. (If special modifications have been made by the user, please describe.)

\_\_\_\_\_

This page left blank intentionally .





Specifications are subject to change without notice.  
All Keithley trademarks and trade names are the property of Keithley Instruments, Inc.  
All other trademarks and trade names are the property of their respective companies.

---

**KEITHLEY**

A G R E A T E R M E A S U R E O F C O N F I D E N C E

**Keithley Instruments, Inc.**

Corporate Headquarters • 28775 Aurora Road • Cleveland, Ohio 44139 • 440-248-0400 • Fax: 440-248-6168 • 1-888-KEITHLEY • [www.keithley.com](http://www.keithley.com)

**[www.valuetronics.com](http://www.valuetronics.com)**