

KEITHLEY

**Model 192
Instruction Manual**

**Contains Operating and Servicing Information for
Model 192 Programmable DMM and Model 1910 AC Option**

**Publication Date: June 1984
Document Number: 30963 Rev. C**

WARRANTY

Keithley Instruments, Inc. warrants this product to be free from defects in material and workmanship for a period of 1 year from date of shipment. During the warranty period, we will, at our option, either repair or replace any product that proves to be defective.

To exercise this warranty, write or call your local Keithley representative, or contact Keithley headquarters in Cleveland, Ohio. You will be given prompt assistance and return instructions. Send the instrument, transportation prepaid, to the indicated service facility. Repairs will be made and the instrument returned, transportation prepaid. Repaired products are warranted for the balance of the original warranty period, or at least 90 days.

LIMITATION OF WARRANTY

This warranty does not apply to defects resulting from unauthorized modification or misuse of any product or part. This warranty also does not apply to fuses, batteries, or damage from battery leakage.

This warranty is in lieu of all other warranties, expressed or implied, including any implied warranty of merchantability or fitness for a particular use. Keithley Instruments, Inc. shall not be liable for any indirect, special or consequential damages.

STATEMENT OF CALIBRATION

This instrument has been inspected and tested in accordance with specifications published by Keithley Instruments, Inc.

The accuracy and calibration of this instrument are traceable to the National Bureau of Standards through equipment which is calibrated at planned intervals by comparison to certified standards maintained in the Laboratories of Keithley Instruments, Inc.

KEITHLEY

Keithley Instruments, Inc. / Instruments Division
28775 Aurora Road / Cleveland, Ohio 44139 / U.S.A.
Phone: (216) 248-0400 / Telex: 98-5469

WEST GERMANY: Keithley Instruments GmbH / Heiglhofstr. 5 / 8000 München 70 / (089) 710020 / Telex: 52-12160 / Telefax: (089) 710 02 59
GREAT BRITAIN: Keithley Instruments, Ltd. / 1, Boulton Road / Reading, Berkshire RG 2 ONL / (0734) 86-12-87/88 / Telex: 84-7047
FRANCE: Keithley Instruments SARL / 2, bis rue Léon Blum / B.P. 60 / 91121 Palaiseau Cedex / (6) 011-51-55 / Telex: 600-933
NETHERLANDS: Keithley Instruments BV / Avelingen-West 49 / Postbus 559 / NL-4202 MS Gorinchem / 0031-1830-35333 / Telex: 24-684
SWITZERLAND: Keithley Instruments SA / Kriesbachstr. 4 / 8600 Dubendorf / 01/821-94-44 / Telex: 57-536
AUSTRIA: Keithley Instruments Ges.m.b.H. / Doblinger Haupstr. 32 / 1190 Wien / 314 289 / Telex: 13-4500
ITALY: Keithley Instruments, SRL / Viale S. Gimignano 4/A / 20100 Milano, Italy / 4120360

**Instruction Manual
Model 192
Programmable DMM**

**© 1982, Keithley Instruments, Inc.
Cleveland, Ohio, U.S.A.
Document Number: 30963**

SPECIFICATIONS

DC VOLTS

RANGE	RESOLUTION			INPUT RESISTANCE	5 1/2-DIGIT ACCURACY ±(% of rdg + digits)			TEMPERATURE COEFFICIENT ±(1% rdg + digits)/°C 0°-18°C & 28°-50°C
	6 1/2*	5 1/2	4 1/2**		24 HR. 23°C ±1°C	90 DAYS 18° to 28°C	1 YEAR 18° to 28°C	
0.2 V		1 μV	10 μV	> 1000MΩ	0.004+2***	0.005+2***	0.009+2***	0.0003+1
2 V	1 μV	10 μV	100 μV	> 1000MΩ	0.003+1.5	0.005+1.5	0.007+1.5	0.0003+0.1
20 V	10 μV	100 μV	1mV	> 1000MΩ	0.003+1	0.005+1	0.009+1	0.0004+0.1
200 V	100 μV	1mV	10mV	10MΩ	0.004+2	0.007+2	0.010+2	0.0007+0.1
1200 V	1mV	10mV	100mV	10MΩ	0.004+1	0.007+1	0.011+1	0.0007+0.1

*Multiply digit error by 10 for 6 1/2-digit accuracy.

**Using Model 1923 Interface.

***After pushbutton zeroing.

MAXIMUM ALLOWABLE INPUT: 1200V peak.

CMRR: Greater than 120dB at DC and 50 or 60Hz (with 1kΩ in either lead).

NMRR: Greater than 60dB at 50 or 60Hz.

BENCH READING RATE: 8/s.

SETTLING TIME: 250ms to within 6 digits at 5 1/2-digit resolution.

OHMS

RANGE	RESOLUTION			MAXIMUM OUTPUT		5 1/2-DIGIT ACCURACY ±(% of rdg + digits)			TEMP. COEFFICIENT ±(1% rdg + digits)/°C 0°-18°C & 28°-50°C
	6 1/2*	5 1/2	4 1/2**	I SHORT	V OPEN	24 HR. 23°C ±1°C	90 DAYS 18°-28°C	1 YR. 18°-28°C	
0.2 kΩ		1mΩ	10mΩ	-5 mA	-0.5V	0.0035+2***	0.007+2***	0.010+2***	0.001+0.7
2 kΩ	1mΩ	10mΩ	100mΩ	-5 mA	-5 V	0.0035+2	0.007+2	0.010+2	0.001+0.1
20 kΩ	10mΩ	100mΩ	1 Ω	-500 μA	-5 V	0.0035+1	0.007+2	0.010+2	0.001+0.1
200 kΩ	100mΩ	1 Ω	10 Ω	-50 μA	-5 V	0.0035+1	0.007+2	0.010+2	0.001+0.1
2000 kΩ	1 Ω	10 Ω	100 Ω	-5 μA	-5 V	0.005+1	0.010+2	0.010+2	0.0012+0.1
20 MΩ	10 Ω	100 Ω	1 kΩ	-0.5 μA	-5 V	0.040+1	0.07+1	0.07+1	0.01+0.1

*Multiply digit error by 10

**Using Model 1923 Interface.

***After pushbutton zeroing.

CONFIGURATION: Automatic 2- or 4-terminal.

MAXIMUM ALLOWABLE INPUT: 360V peak or 250V rms.

BENCH READING RATE: 8/s on 0.2kΩ—2000kΩ ranges; 4/s on 20MΩ range.

SETTLING TIME: 250ms to within 6 digits at 5 1/2-digit resolution on 0.2kΩ—2000kΩ ranges; 500ms on 20MΩ range.

AC VOLTS (Option 1910)

RANGE	RESOLUTION			50Hz-20kHz	5 1/2-DIGIT ACCURACY ±(% of rdg + digits)		
	6 1/2*	5 1/2	4 1/2**		1 YEAR, 18°-28°C (above 1000 counts)	TEMPERATURE COEFFICIENT ±(1% rdg + digits)/°C 0°-18°C & 28°-50°C	
2 V	1 μV	10 μV	100 μV	0.1 +10	1+20	0.015+0.5	0.05+0.5
20 V	10 μV	100 μV	1mV	0.1 +10	1+20	0.015+0.5	0.05+0.5
200 V	100 μV	1mV	10mV	0.1 +10	1+20	0.015+0.5	0.05+0.5
1000 V	1mV	10mV	100mV	0.15+10†	1+20‡	0.020+0.5‡	0.05+0.5‡

*Multiply digit error by 10

**Using Model 1923 Interface

†50Hz-10kHz.

‡20Hz-50Hz & 10kHz-20kHz

RESPONSE: Average, calibrated in rms of a sine wave.

MAXIMUM ALLOWABLE INPUT: 1000V rms sine or DC, 2 × 10⁷ V•Hz.

CMRR: Greater than 60dB at DC, 50 & 60Hz (1kΩ in either lead).

INPUT IMPEDANCE: 2MΩ shunted by less than 50pF.

BENCH READING RATE: 2/s.

SETTLING TIME: Less than 1.3s to within 0.05% of final reading.

DIMENSIONS, WEIGHT: 127mm high × 216mm wide × 359mm deep (5" × 8 1/2" × 14 1/4"). Net weight 3.4kg (7.5 lbs.).

192 Spec Addendum

The following information is supplied as clarification of 192 specifications.

1. NMRR. To prevent AD saturation, peak AC+DC value must be less than full scale on any range.
2. IEEE low to power line ground isolation is 1MΩ.
3. Four terminal lead resistance: Maximum per lead for additional 1 digit error at 5 1/2 digits.

Range	Resistance
.2k	7Ω
2k	22Ω
20k	70Ω
200k	220Ω
2000k	700Ω
20M	2200Ω

4. Input current. With 1MΩ shunt on 2V range, display should be less than 5 digits (< 50pA) at T_A = 23°C (use filter program 2).

FRONT PANEL PROGRAMS

PROGRAM	NAME	DESCRIPTION	% DEVIATION
0	CLEAR	Cancels Programs 3 through 7	
1	RESOLUTION	Selects 5 1/2- or 6 1/2-digit resolution	
2	FILTER	Selects extra digital filtering	
3	OFFSET SCALE	Displays the result of Y = aX + b a and b are entered from the front panel	

	% DEVIATION	DATA LOGGER
4	% DEVIATION	Displays the percent deviation from an entered value
5	MIN MAX	Remembers the minimum and maximum reading for front panel recall
6	HI LO PASS	Displays HI, LO or PASS defined by entered limits. Status output available with 1923 option
7	DATA LOGGER	Saves up to 100 readings for front panel recall. Interval programmable up to 1 hour

TABLE OF CONTENTS

PARAGRAPH	TITLE	PAGE
SECTION 1—GENERAL INFORMATION		
1.1	Introduction	1-1
1.2	Features	1-1
1.3	Warranty Information	1-1
1.4	Manual Addenda	1-1
1.5	Safety Symbols and Terms	1-1
1.6	Unpacking and Inspection	1-1
1.7	Specifications	1-1
1.8	Preparation for Use	1-1
1.9	Line Power	1-2
1.10	Line Voltage Selection	1-2
1.11	Line Frequency Selection	1-2
1.12	Repacking for Shipment	1-2
SECTION 2—ACCESSORIES		
2.1	Introduction	2-1
2.2	Rack Mounting Kits	2-1
2.2.1	Model 1019A Rack Mounting Kit	2-1
2.2.2	Model 1019S Rack Mounting Kit	2-1
2.3	Model 1600A High Voltage Probe	2-1
2.4	Model 1641 Kelvin Test Lead Set	2-1
2.5	Model 1651 50 Ampere Shunt	2-1
2.6	Model 1681 Clip-On Test Lead Set	2-1
2.7	Model 1682A RF Probe	2-2
2.8	Model 1683 Universal Test Lead Kit	2-2
2.9	Model 1685 Clamp-On AC Current Probe	2-2
2.10	Model 1901 Current Adapter	2-2
2.11	Model 1910 AC Voltage Option	2-3
2.12	Model 1920 TRMS AC Volt Option	2-3
2.13	Model 1923 IEEE-488 Interface	2-3
2.14	Model 1924 Rear Input Adapter	2-3
2.15	Model 7008 IEEE-488 Cable	2-3
SECTION 3—FRONT AND REAR PANEL CONTROLS		
3.1	Introduction	3-1
3.2	Front Panel	3-1
3.3	Bench Mode of Operation	3-1
3.4	Bench Programming Mode of Operation	3-1
3.5	System Mode of Operation	3-1
3.6	Rear Panel	3-2
SECTION 4—BASIC DMM OPERATION		
4.1	Introduction	4-1
4.2	Power Up	4-1
4.3	Operating Instructions	4-1
4.4	Zero	4-1
4.5	Overrange Indication	4-2
4.6	Filter	4-2
4.7	DC Voltage Measurement	4-3
4.8	Resistance Measurement	4-3
4.9	Four-Wire Ohms Measurement	4-4
4.10	AC Voltage Measurement (1910 AC Option)	4-4
4.11	AC Voltage Measurement (1920 TRMS Option)	4-5

TABLE OF CONTENTS (CONT.)

PARAGRAPH	TITLE	PAGE
SECTION 5—FRONT PANEL PROGRAMS		
5.1	Introduction	5-1
5.2	Program Notes	5-1
5.3	Program 0 Clear	5-3
5.4	Program 1. Resolution	5-4
5.5	Program 2. Filter	5-4
5.6	Program 3. Offset/Scale	5-4
5.7	Program 4. Percent Deviation	5-5
5.8	Program 5. Min/Max	5-6
5.9	Program 6. HI/LO/PASS	5-7
5.10	Program 7. Data Logger	5-8
5.11	IEEE Buffer Operation	5-9
5.12	Program 8. Service Program	5-9
SECTION 6—PERFORMANCE VERIFICATION		
6.1	Introduction	6-1
6.2	Environmental Conditions	6-1
6.3	Recommended Test Equipment	6-1
6.4	Initial Conditions	6-1
6.5	Performance Verification	6-1
6.5.1	DC Voltage Accuracy Check (20V to 1200V ranges)	6-1
6.5.2	DC Voltage Accuracy Check (.2V to 2V ranges)	6-2
6.5.3	AC Voltage Accuracy Check (With Model 1910 AC Voltage Option Installed)	6-2
6.5.4	Resistance (Ω) Accuracy Check	6-2
SECTION 7—THEORY OF OPERATION		
7.1	Introduction	7-1
7.2	Overall Functional Description	7-1
7.3	Analog Circuit Description	7-3
7.3.1	Input Multiplexer	7-3
7.3.2	DC Voltage Measurement	7-4
7.3.3	Resistance Measurement	7-5
7.3.4	AC Voltage Measurement	7-7
7.3.5	Input Buffer Amplifier	7-7
7.3.6	A/D Converter	7-7
7.4	Digital and Display Circuit Description	7-8
7.4.1	Microcomputer (Refer to Schematic 30975D)	7-8
7.4.2	Memory	7-10
7.4.3	Address Decoder	7-11
7.4.4	Reset	7-11
7.4.5	Front Panel Switch Port	7-11
7.4.6	Line Frequency	7-11
7.5	A/D Control	7-11
7.5.1	Clock Circuit	7-14
7.6	Display Circuit	7-14
7.7	Power Supply	7-14
SECTION 8—MAINTENANCE		
8.1	Introduction	8-1
8.2	Calibration	8-1
8.2.1	Recommended Test Equipment	8-1
8.2.2	Environmental Conditions	8-1

TABLE OF CONTENTS (CONT.)

PARAGRAPH	TITLE	PAGE
8.2.3	Warm Up	8-1
8.2.4	Calibration Adjustments	8-1
8.3	Troubleshooting Set-Up Procedures	8-2
8.3.1	Line Power Fuse (F101) Replacement	8-2
8.3.2	Line Voltage Selection	8-4
8.3.3	Disassembly	8-4
8.3.4	Special Handling of Static Sensitive Devices	8-5
8.4	Troubleshooting Procedure	8-5
8.4.1	Line Power	8-6
8.4.2	A/D Converter and Display	8-6
8.4.3	AC Converter	8-6
8.4.4	DC Attenuator and Ohms Sources and Resistors	8-6
8.4.5	Digital Board	8-6
SECTION 9—REPLACEABLE PARTS		
9.1	Introduction	9-1
9.2	Parts List	9-1
9.3	Ordering Information	9-1
9.4	Factory Service	9-1
9.5	Schematic Diagrams and Component Location Drawings	9-1

LIST OF ILLUSTRATIONS

FIGURE	TITLE	PAGE
1-1	Instrument Packaging	1-2
2-1	Model 1019 Rack Mounting Kit	2-1
2-2	Model 1600A High Voltage Probe	2-1
2-3	Model 1641 Kelvin Test Lead Set	2-1
2-4	Model 1651 50 Ampere Shunt	2-1
2-5	Model 1681 Clip-On Test Lead Set	2-2
2-6	Model 1682A RF Probe	2-2
2-7	Model 1683 Universal Test Lead Kit	2-2
2-8	Clamp-On AC Current Probe	2-2
2-9	Model 1901 Current Adapter	2-3
2-10	Model 1910 AC Voltage Option	2-3
2-11	Model 1920 TRMS AC Voltage Option	2-3
2-12	Model 1923 IEEE-488 Interface	2-3
2-13	IEEE-488 Connector	2-3
2-14	Model 1924 Rear Input Adapter	2-4
3-1	Model 192 Front Panel	3-1
3-2	Model 192 Rear Panel	3-2
4-1	Effect of Zero Function on Dynamic Range of Measurements	4-2
4-2	Input Filter Response Graph	4-2
4-3	DC Voltage Measurements	4-3
4-4	Resistance Measurements	4-4
4-5	Four-Wire Resistance Measurement	4-4
4-6	AC Voltage Measurements	4-4
5-1	Front Panel Program Buttons	5-2
6-1	Test Circuit .2mV and 2V	6-2
7-1	Basic Block Diagram	7-1
7-2	Simplified Multiplexer Schematic	7-2
7-3	DC Voltage Measurement	7-3
7-4	FET Switching Sequence for DC Voltage Measurement (Bench Mode of Operation)	7-4
7-5	DC Voltage Measurement FET Switching Sequence (System Mode of Operation)	7-4
7-6	Resistance Measurement Simplified Circuit	7-5
7-7	FET Switching Sequence for Ohms Measurement	7-6
7-8	Affect of Lead Resistance in 2-Terminal Ohms Measurements	7-6
7-9	Affect of Lead Resistance in 4-Terminal Ohms Measurements	7-6
7-10	Block Diagram AC Volts Operation	7-7
7-11	AC Volts Operation Flow Chart	7-8
7-12	Simplified Input Buffer Schematic	7-9
7-13	Simplified A/D Converter Schematic	7-9
7-14	A/D Converter Integrator Output Waveform	7-10
7-15	Microcomputer Block Diagram	7-12
7-16	Charge Balance Timing	7-13
7-17	Single Slope Phase	7-14
7-18	Simplified Schematic of Latch	7-15
7-19	Simplified Oscillator/Divider Diagram	7-15
7-20	Display Schematic	7-16
8-1	Adjustment Locations	8-3
9-1	Exploded View With Mechanical Parts	9-2
9-2	AC Converter, Component Location Drawing	9-11
9-3	Mother Board, Component Location Drawing	9-13
9-4	Analog Board, Component Location Drawing	9-17
9-5	Display Board, Component Location Drawing	9-21

LIST OF ILLUSTRATIONS (CONT.)

FIGURE	TITLE	PAGE
9-6	AC Converter, Schematic Diagram	9-23
9-7	Mother Board, Schematic Diagram	9-25
9-8	Analog Board, Schematic Diagram	9-29
9-9	Display Board, Schematic Diagram	9-33

LIST OF TABLES

TABLE	TITLE	PAGE
4-1	Line Voltage Selection	4-1
4-2	Maximum Input	4-1
4-3	Resistance Ranges	4-3
4-4	Maximum Four-Wire Test Lead Resistance	4-4
5-1	Front Panel Program Summary	5-1
5-2	Data Point Times	5-9
6-1	Recommended Test Equipment for Performance Verification	6-1
6-2	DC Voltage Performance Check (20V to 1200V Range)	6-2
6-3	AC Voltage Accuracy Check	6-2
6-4	Zero Reading	6-3
6-5	Resistance Accuracy Check	6-3
7-1	Settling Delays, SN on to Turn on of Integrator	7-8
7-2	Memory Byte Locations	7-10
7-3	Functions of Latch Outputs	7-13
7-4	Power Supply Component Identification	7-15
8-1	Recommended Test Equipment for Calibration	8-1
8-2	Calibration Procedures	8-2
8-3	Fuse Replacement	8-4
8-4	Line Voltage Selection	8-4
8-6	Test Number Summarization	8-6
8-5	Static Sensitive Devices	8-5
8-7	Program 8 A/D Test-FET Switching Sequence	8-7
8-8	Line Power Checks	8-8
8-9	A/D Converter Checks	8-8
8-10	Display Checks	8-9
8-11	AC Converter Checks (Model 1910)	8-9
8-12	DC Attenuator Checks	8-10
8-13	Ohms Source and Resistors Checks	8-11
8-14	Digital Board Checks	8-11
9-1	Model 192 Drawing Package	9-1
9-2	AC Converter PC-496, Parts List	9-3
9-3	Mother Board PC-559, Parts List	9-4
9-4	Analog Board PC-560, Parts List	9-6
9-5	Display Board PC-530, Parts List	9-9

SECTION 1 GENERAL INFORMATION

1.1 INTRODUCTION

This instruction manual contains complete operating instructions for the Keithley Model 192. Detailed descriptions of the available options for the Model 192 are provided (separate instruction manuals are supplied with the Model 1920 and Model 1923), along with a theory of operation, calibration and service instructions for maintaining the instrument. A complete parts list with schematics and component layouts is also provided at the end of this manual.

The Model 192 is a 6½ digit, 2,000,000 count, fast autoranging DMM. With the IEEE-488 interface option (Model 1923), the Model 192 becomes fully programmable. DC Volts and Ohms functions are standard. Measurements of 1μV to 1200V are attainable on 5 voltage ranges, and 2- and 4-terminal measurements of 1mΩ to 20MΩ are attainable on 6 resistance ranges. With the addition of the Model 1910 AC Voltage Option, the Model 192 will provide readings from 10μV to 1000VAC on 4 ranges. True Root Mean Square (TRMS) AC voltages can also be attained with the use of the Model 1920 TRMS ACV Option. Because the Models 1910, 1920, and 1923 are easily field installed, these options can be added at any time.

1.2 FEATURES

The Model 192 includes the following features:

- **Front Panel Programs**—The internal programs in the Model 192 are accessible from the front panel. Descriptions of these programs can be found in the detailed specifications which precede this Section and in Section 5.
- **Data Storage**—Registers for storing 100 readings are provided in the basic Model 192. These storage registers are utilized by Front Panel Program 7, Data Logger (see Section 5).
- **Multiple Inputs**—Multiple inputs provide access to DCV, ACV, and Ohms terminals simultaneously. This enables systems designers to optimize their switching matrices for the parameter being measured. In addition, in some simple systems, switching can be eliminated altogether. For systems that require only one input, the Model 1924 Rear Panel Input Adapter is available as an option.
- **One Button Zero**—The front panel zero is activated by pushing one button. The zero offset is automatically scaled when a new range is selected. Unique offset settings are saved for each function.

1.3 WARRANTY INFORMATION

Warranty information is given on the inside front cover of this manual. If there is a need to exercise the warranty, contact the Keithley representative in your area to determine

the proper action to be taken. Keithley maintains service facilities in the United States, West Germany, Great Britain, France, the Netherlands, Switzerland, and Austria. Information concerning the application, operation or service of your instrument may be directed to the applications Engineer at any of the above locations. Check the inside Front Cover of this manual for addresses.

1.4 MANUAL ADDENDA

Improvements or changes to this manual will be explained on an addendum attached to the inside back cover.

1.5 SAFETY SYMBOLS AND TERMS

Safety symbols used are as follows:

The symbol  on the instrument denotes that the user should refer to the operating instructions.

The symbol  on the instrument denotes that 1000V or more may be present on the terminal(s).

The **WARNING** used in this manual explains dangers that could result in personal injury or death.

The **CAUTION** used in this manual explains hazards that could damage the instrument.

1.6 UNPACKING AND INSPECTION

The Model 192 was carefully inspected both mechanically and electrically before shipment. Upon receiving the Model 192, *unpack all items from the shipping container and check for any obvious damage that may have occurred during transit. Report any damage to the shipping agent. Retain and use the original packaging materials if reshipment is necessary.* The following items are shipped with all Model 192 orders:

- Model 192 Programmable DMM
- A Model 192 Instruction Manual
- Installed or separate optional accessories, as ordered

1.7 SPECIFICATIONS

For Model 192 detailed specifications, refer to the specifications that precede this section.

1.8 PREPARATION FOR USE

The Model 192 is shipped ready for use on the line voltage marked on its rear panel. The line frequency (50 to 400Hz) is selected automatically by the Model 192 during power up. If

the Model 1923 IEEE Interface is installed it will be set to the Addressable mode and at Address 8.

1.9 LINE POWER

The Model 192 is provided with a 3-wire line cord which mates with a third wire earth grounded receptacle. The instrument will operate on two of four voltage ranges listed in Table 8-4. These ranges may be selected by positioning an internal slide switch and installing the appropriate fuse for that range. An optional line voltage range of 90 to 110 volts is available by special order. Instruments with this range use a different transformer.

1.10 LINE VOLTAGE SELECTION

Refer to Section 8 Maintenance to select the proper line voltage settings.

1.11 LINE FREQUENCY SELECTION

Line frequency is sensed automatically by the Model 192 during power up. The instrument will operate at 50 to 400Hz and will display F60 at 60Hz or F50 at either 50Hz or 400Hz.

1.12 REPACKING FOR SHIPMENT

The Model 192 should be packed in its original carton using the packaging method shown in Figure 1-1. Before packaging, wrap the instrument in plastic. After it is placed in the box, surround the instrument with styrofoam packaging material.

If the Model 192 is to be returned to Keithley Instruments for calibration or repair, include the following:

- ATTENTION REPAIR DEPARTMENT on the address label
- Warranty status of the instrument
- Completed service form

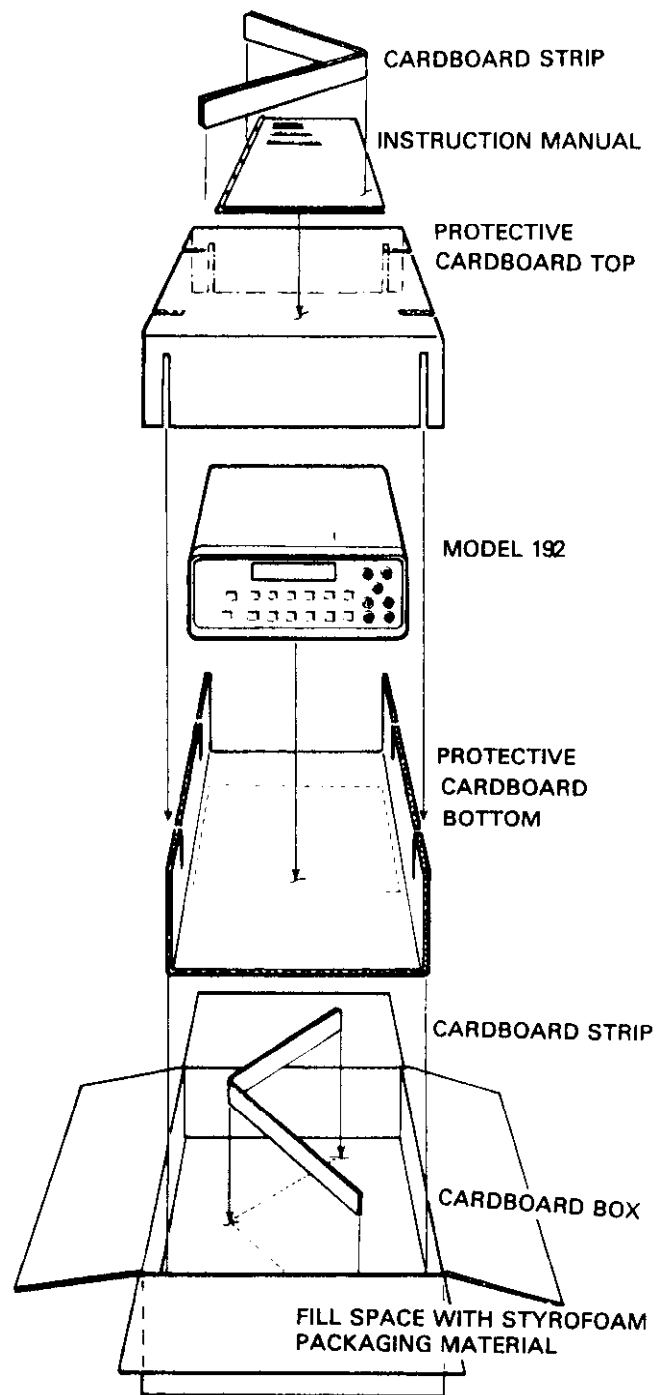

Figure 1-1. Instrument Packaging

SECTION 2 ACCESSORIES

2.1 INTRODUCTION

This section describes the various accessories and options available for use with the Model 192 DMM.

2.2 RACK MOUNTING KITS

2.2.1 Model 1019A Rack Mounting Kit

The Model 1019A is a universal rack mounting kit for the Model 192. Two different front panels are provided to allow left, right, or dual (side-by-side) installation. (See Figure 2-1.)

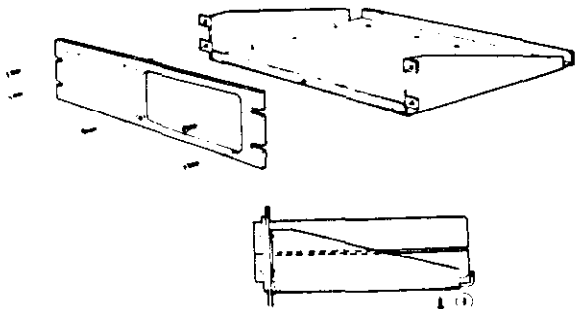

PARTS LIST

ITEM	PART NO	DESCRIPTION	QTY
1	30958C	Staking, Support Plate	1
2	30959C	Staking, Rt. Hand Brkt.	1
3	30960C	Staking, Left Hand Brkt.	1
4	30956D	Panel, Front Dual	1
5	30957D	Panel, Front, Single	1
6	#8-32 Kep Nut	6
7	#6-32 x 1/4 Phil Pan Hd Sc	1
8	#6-32 x 1/4 Self Thd Sc Type 'T'	2
9	#10-32 x 1/2" Truss Head Sc.	4

Figure 2-1. Model 1019 Rack Mounting Kit

2.2.2 Model 1019S Rack Mounting Kit

Model 1019S slide rack mounting kit enables one or two half rack size instruments to be rack mounted with the added feature of sliding the instrument(s) for easy access. The dimensions are 133mm x 483mm (5 1/4 x 19 in).

2.3 MODEL 1600A HIGH VOLTAGE PROBE

The Model 1600A (Figure 2-2) extends the DMM measurement capabilities to 40kV. It has a 1000:1 division ratio (1 volt on the DMM corresponds to 1 kilovolt).

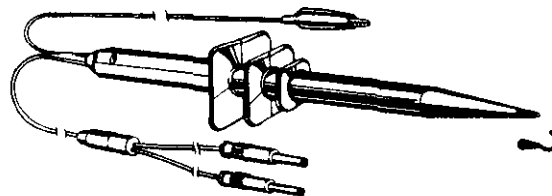

Figure 2-2. Model 1600A High Voltage Probe

2.4 MODEL 1641 KELVIN TEST LEAD SET

The Model 1641 test leads (Figure 2-3) are used in making 4-terminal measurements. The test leads (1 pair) are twin-lead cables 1.2m (48 inches) long. Each cable is terminated by a twin-banana plug and a spring-clip Kelvin contact. Plug the twin banana plugs into the DMM horizontally (HI to HI and LO to LO).

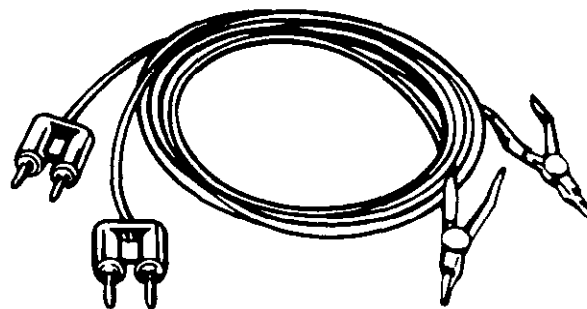

Figure 2-3. Model 1641 Kelvin Test Lead Set

2.5 MODEL 1651 50 AMPERE SHUNT

The Model 1651 (Figure 2-4) allows current measurements to be made from 0 to 50 amperes DC and up to 50 amperes AC with AC Voltage option. It is a 0.001 ohm + 1% 4-terminal shunt. A 50 ampere current will correspond to 50mV.

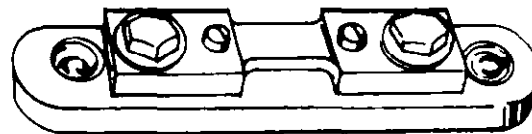

Figure 2-4. Model 1651 50 Ampere Shunt

2.6 MODEL 1681 CLIP-ON TEST LEAD SET

The Model 1681 (Figure 2-5) contains two leads 1.2m (48in.) long, terminated with banana plug and spring-action clip-on probe.

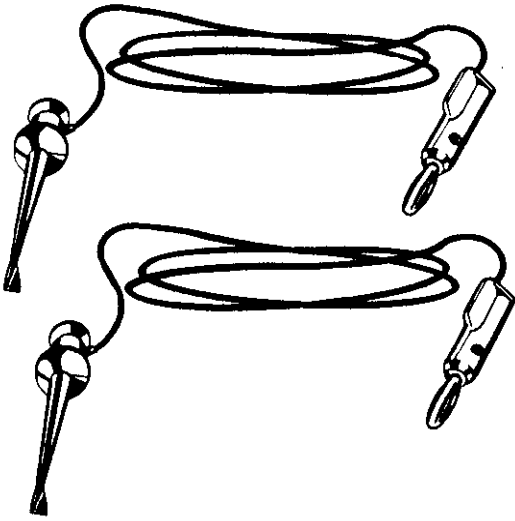

Figure 2-5. Model 1681 Clip-On Test Lead Set

2.7 Model 1682A RF Probe

The Model 1682A is an RF probe that permits measurements of AC voltages at frequencies from 100kHz to 250kHz. Connect the probe to the input terminals of the DMM. Select the DCV function and the appropriate range. The Model 1682A will give an output of one volt for an input of one volt rms when used with instruments having an input impedance of 10M Ω . (See figure 2-6.)

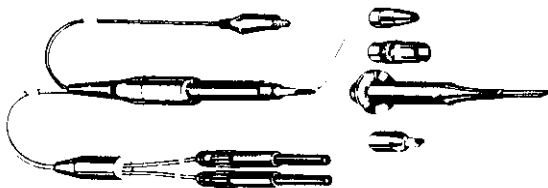

Figure 2-6. Model 1682A RF Probe

2.8 MODEL 1683 UNIVERSAL TEST LEAD KIT

The Model 1683 consists of two test leads 1.2m (48in.) long with 12 screw-in tips, 2 banana plugs, 2 spade lugs, 2 alligator clips with boots, 2 needle tips with chucks, and 4 heavy-duty tip plugs. (See Figure 2-7.)

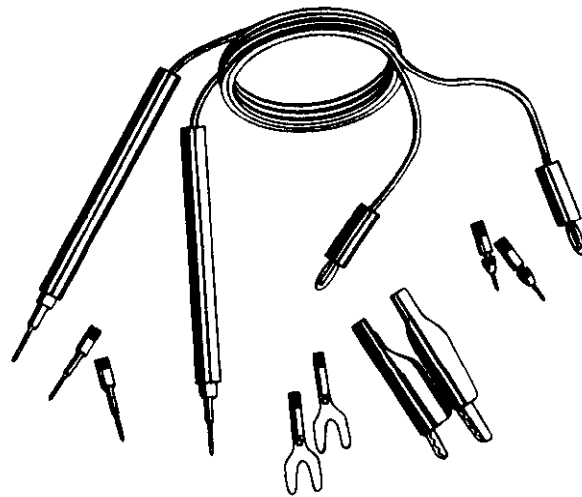

Figure 2-7. Model 1683 Universal Test Lead Kit

2.9 MODEL 1685 CLAMP-ON AC CURRENT PROBE

The Model 1685 (Figure 2-8) measures 50Hz and 60Hz AC current by clamping onto a single conductor. Interruption of the current path is unnecessary. The Model 1685 detects current by sensing magnetic field produced by current.

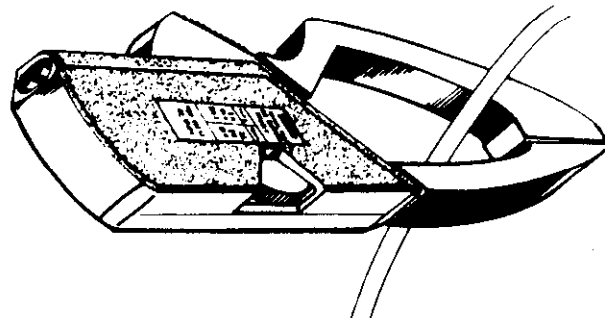

Figure 2-8. Clamp-On AC Current Probe

2.10 MODEL 1901 CURRENT ADAPTER

The Model 1901 (Figure 2-9) allows the DMM to read DC current from 1nA/digit to 2000mA. With the Model 1910 AC voltage option it reads from 10nA/digit to 2000mA. The Model 1901 plugs into the INPUT terminals of the Model 192. Maximum allowable continuous voltage drop (full scale input voltage burden) is 200mV. Shunt resistors are connected to eliminate contact resistance errors. Use the Model 192 200mVDC range and 2VAC range for DC current and AC current respectively. Input voltage burden can be reduced by selecting the lowest shunt that provides the necessary resolution.

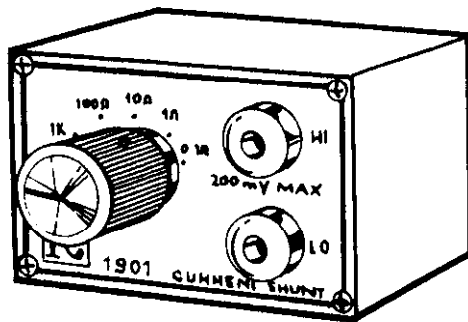

Figure 2-9. Model 1901 Current Adapter

2.11 MODEL 1910 AC VOLTAGE OPTION

The Model 1910 (Figure 2-10) is a factory or field installable option which allows the DMM to read AC volts from $10\mu\text{V}/\text{digit}$ to 1000V. The Model 1910 is internally installed in the Model 192. It is important to note that field installation or removal/replacement of the Model 1910 requires recalibration of the Model 1910. Refer to the instructions accompanying this option for operation and installation information.

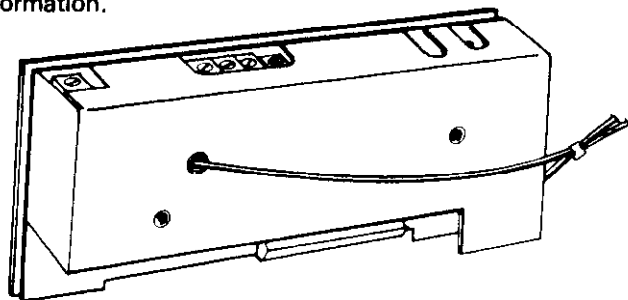

Figure 2-10. Model 1910 AC Voltage Option

2.12 MODEL 1920 TRMS AC VOLT OPTION

The Model 1920 is a True Root Mean Square (TRMS) AC plug-in option for the Model 192 (Figure 2-11). The Model 1920 enables the Model 192 to measure the TRMS value of an AC signal. When the Model 1920 is installed, an AC + DC function is available. The Model 1920 has four ranges on which an AC signal can be measured. It is field installable. Refer to the instructions accompanying this option for operation and installation information. It is important to note that field installation or removal/replacement of the Model 1920 requires recalibration of the Model 1920.

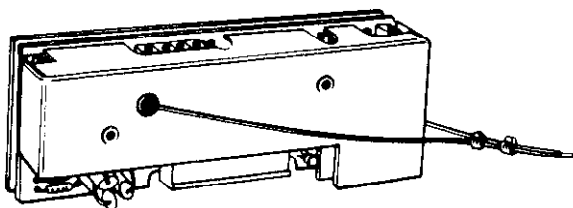

Figure 2-11. Model 1920 TRMS AC Voltage Option

2.13 MODEL 1923 IEEE-488 INTERFACE

The Model 1923 is a microprocessor-based IEEE Standard 488-1978 interface that provides the logic and control necessary to interface the Model 192. In the Talk Only mode the Model 192 can send data to one or more listeners without the use of a controller. In the Talk/Listen mode the Model 192 can send or receive data over the IEEE Bus when addressed by a systems controller. (See Figures 2-12 and 2-13.) Also provides status output and external trigger connector to rear panel.

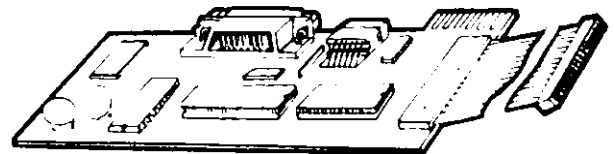

Figure 2-12. Model 1923 IEEE-488 Interface

Refer to the Model 1923 IEEE-488 Interface Instruction Manual for operation and installation procedures.

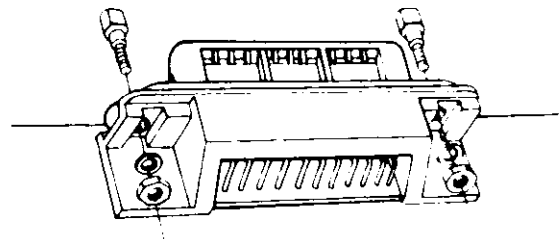

Figure 2-13. IEEE-488 Connector

2.14 MODEL 1924 REAR INPUT ADAPTER

The basic Model 192 has multiple inputs on the front panel. The Model 1924 Rear Input Adapter provides multiple rear inputs without the Model 1923 IEEE option. (See Figure 2-14.) The IEEE option must be installed with the Model 1924 to use the single rear input on the Model 1924.

Necessary switching signals for the Model 1924 Input option are obtained through the status port connector which is located on the rear panel. The status port is an integral part of the IEEE option.

2.15 Model 7008 IEEE-488 CABLE

The Model 7008 is a 6ft (2m) IEEE-488 Digital Cable. The cable has 24 stranded wire conductors and is terminated with IEEE Standard 488 connectors.

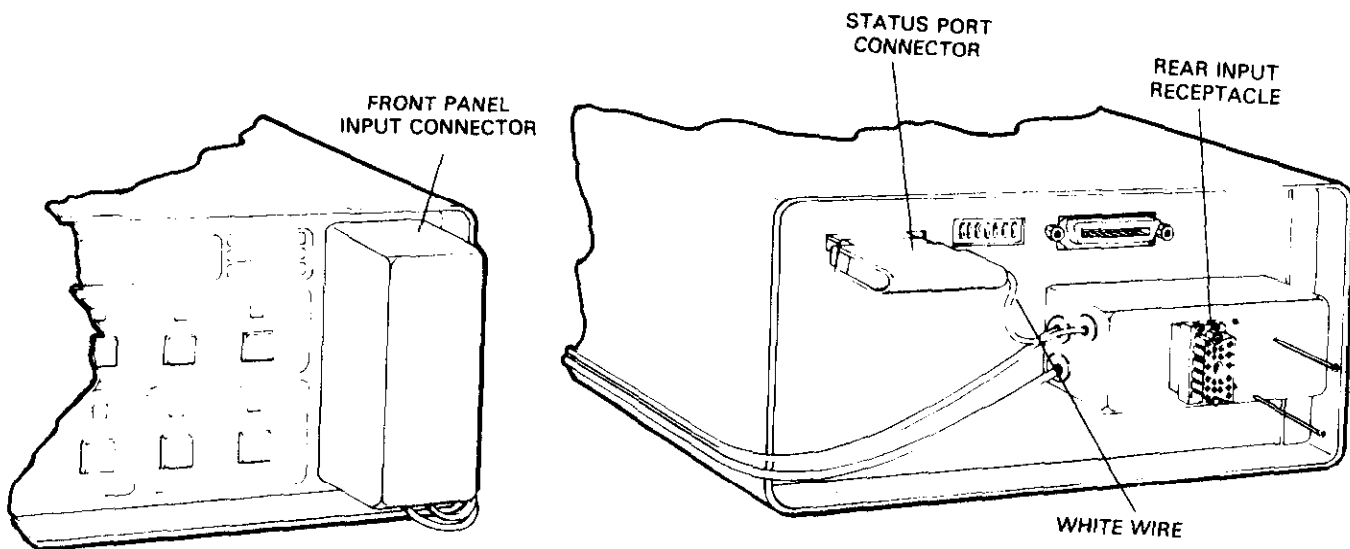

Figure 2-14. Model 1924 Rear Input Adapter

SECTION 3 FRONT AND REAR PANEL CONTROLS

3.1 INTRODUCTION

This section describes the Model 192 front and rear panel controls. Refer to Figures 3-1 and 3-2.

3.2 FRONT PANEL

The Front panel features are explained under the following modes of operation:

- Bench Mode of Operation
- Bench Programming Mode of Operation
- System Mode of Operation

3.3 BENCH MODE OF OPERATION

Power ON/OFF Button—Power is ON with button IN; power is OFF with button OUT.

Display—Display is direct reading in AC and DC volts. Ohms is read in $k\Omega$, except the $20M\Omega$ range which is read in megohms. $5\frac{1}{2}$ digits of resolution is standard in the Bench mode.

IEEE-488 Bus Indicator—The indicators (Talk, Listen and Remote) are used during remote operation of the Model 192. They can be disregarded during the Bench mode of operation.

Input Terminals—There are separate connections for DCV, ACV, and Ohms with the use of five-way binding posts.

Range Push Buttons—These seven momentary switches are used to select range. The annunciators indicate which range the instrument is in, and if it is in Manual or Auto ranging.

Function Push Buttons—These three push buttons select either DCV, ACV (if the option is installed), or $k\Omega$.

Zero Push Buttons—This button controls the internal Zero program (See paragraph 4-4). An illuminated annunciator indicates Zero function is enabled.

Programming Push Buttons—These two momentary switches are used during the Bench Programming mode of operation. They can be disregarded during the Bench mode.

Tilt Bail—The tilt bail is used as a handle and also to elevate the front of the instrument for better viewing.

3.4 BENCH PROGRAMMING MODE OF OPERATION

Power ON/OFF Button—Power is ON with button IN; power is OFF with button OUT.

Display—The utilization of Front Panel PROGRAM 1 increases resolution to $6\frac{1}{2}$ digits (see paragraph 5.4).

IEEE-488 Bus Indicator—The indicators (Talk, Listen and Remote) are used during remote operation of the Model 192. They can be disregarded during the Bench mode of operation.

Input Terminals—There are separate connections for DCV, ACV, and Ohms with the use of five-way binding posts.

PROGRAM δ through PROGRAM 5—The number δ through 5 and the sign (-) to the left of the Range push buttons are used to select their corresponding programs or enter data.

PROGRAM 7 through PROGRAM 9—The number 7, 8, and 9 at the left of the Function push buttons are used to select their corresponding program or enter data.

PROGRAM 6—The number 6 at the left of the Zero push button is used to select front panel PROGRAM 6 or enter data.

Programming Push Buttons—PRGM—This button enables the selection of front panel programs. RECALL—This button has three function levels or uses. The first function level (RECALL) displays the current program along with data, if any. The second function level (ENT) is used to enter programming data. The third function level is a trigger for the System mode.

3.5 SYSTEM MODE OF OPERATION

Power ON/OFF Switch—Power is ON with button IN; power is OFF with button OUT.

Display—In the System mode, the Model 192's resolution is determined by the conversion rate. Refer to IEEE-488 Bus Operator Manual.

IEEE-488 Bus Indicator—These indicators (Talk, Listen and Remote) identify the present status of the IEEE Bus.

Input Terminal—There are separate connections for DCV, ACV, and Ohms with the use of five-way binding posts.

Range Push Buttons—These seven momentary switches are used to select range. The annunciators indicate which range the instrument is in, and if it is in Manual or Auto Range.

Function Push Buttons—These three push buttons select either DCV, ACV (if the option is installed), or $k\Omega$.

Zero Push Buttons—This button controls the internal Zero program (See paragraph 4.4). An illuminated annunciator indicates Zero function is enabled.

3.6 REAR PANEL

The following information describes Model 192 rear panel controls.

Power Connector—The instrument will operate on four voltage ranges of 50 to 400Hz AC power (see paragraph 1.9 and 1.10).

Fuse—See paragraph 8.5.1 for the proper fuse replacement.
 Status Output* and External Trigger—Six active low outputs and the external trigger input are available through the Status Output Connector. Three of the outputs are function (ACV, DCV, k Ω). The remaining outputs are PASS, LOW,

HIGH which are used with the internal program HI/LO/PASS. The function outputs are continuously active, the PASS, LOW, HIGH outputs are active only when utilizing the HI/LO/PASS program. The external trigger requires a 0 to 5V logic signal and is recognized only when in system mode.

IEEE-488 Interface Connector*—This is the IEEE-488 connection to the Model 192.

Address Switches*—These switches are used to set up the Model 1923 IEEE-488 Interface.

Accessory Mounting Holes—These are threaded mounting holes for the rear input adapter.

* These functions are present when the Model 1923 option is installed.

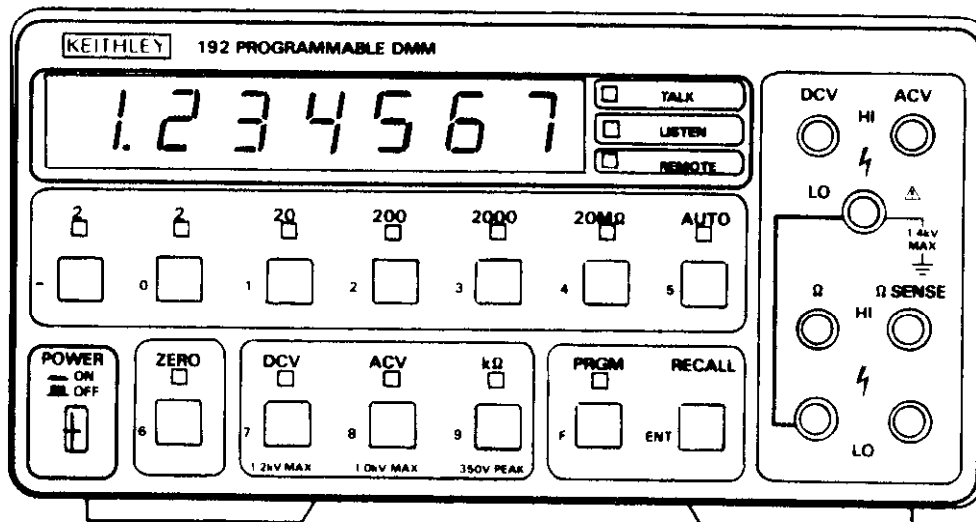

Figure 3-1. Model 192 Front Panel

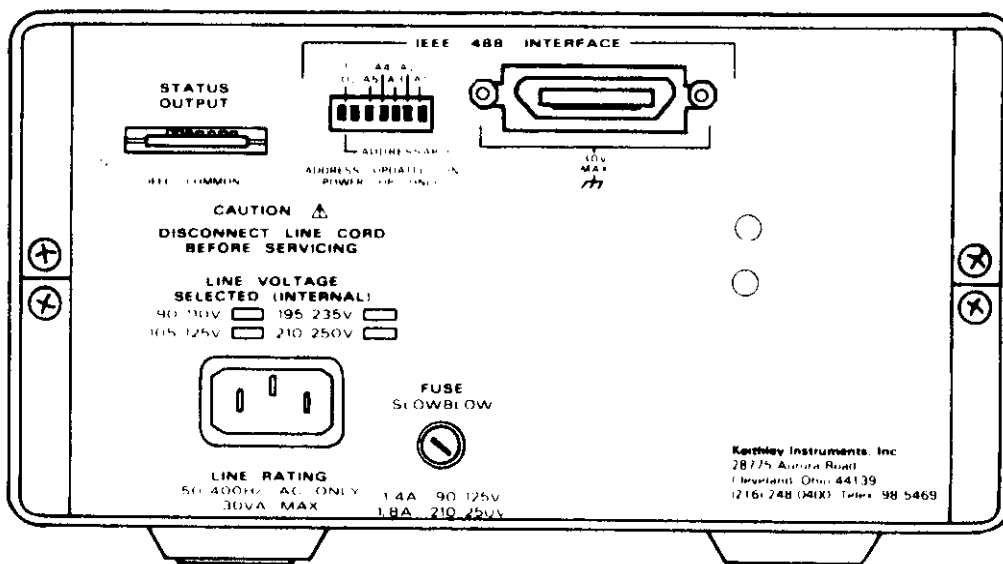

Figure 3-2. Model 192 Rear Panel

SECTION 4 BASIC DMM OPERATION

4.1 INTRODUCTION

This section contains procedures for connecting and operating the Model 192.

4.2 POWER UP

Plug the instrument into the proper power receptacle in accordance with Table 4-1.

Table 4-1. Line Voltage Selection

Input Voltage	Switch Setting S102
105-125VAC	115VAC
210-250VAC	230VAC
90-110VAC*	115VAC
195-235VAC*	230VAC

*For instruments equipped with a low voltage transformer.

Immediately after turning on the Model 192 via the POWER switch, the Display will indicate the following:

1.8.8.8.8.8.8

1. This is a display test. The operator can note inoperative display segments by comparing the Model 192's display with the figure above.
2. In addition, the push button and GPIB annunciators will illuminate. All annunciators will illuminate simultaneously if operating correctly.

After the display test is completed the Model 192 will display the integration period and software level. For example; when the following is displayed:

F60 - C4

1. The Model 192 senses the power line frequency and sets the A/D conversion rate.
2. The F60 indicates that the integration time has been set for 16.6 milliseconds.
3. The C4 is a code that identifies the software revision that is installed in the Model 192.
4. If the following is displayed the F50 indicates that the integration time has been set for 20 milliseconds.

F50 - C4

4.3 OPERATING INSTRUCTIONS

Basic operation of the Model 192 is presented in the following paragraphs. The upper three binding posts are used for voltage input connections. The lower four binding posts are used for ohms connections. The LO binding posts for ACV, DCV and Ω are wired together.

CAUTION

Do not apply voltages between the LO binding posts. Instrument damage may occur.

WARNING

Maximum floating voltage is 1400VDC or peak AC at $< 5 \times 10^6 \text{V} \cdot \text{Hz}$. Do not exceed the maximum floating voltage ratings. Destruction of insulation could present a shock hazard.

The LO inputs may be floated at voltages up to 1.4kV at $5 \times 10^6 \text{V} \cdot \text{Hz}$, with reference to chassis ground. Chassis ground is connected to earth ground with the line power cord and an appropriately grounded three-wire receptacle.

WARNING

Hazardous voltages may be present on the LO input terminals. Any voltage that is applied to LO will also be present at the Ω LO terminals.

CAUTION

Do not exceed maximum input limits given in Table 4-2.

DC voltage sources, AC voltage sources, and Resistance values may be connected to the input terminals simultaneously with consideration for possible ground loops and noise. Refer to Table 4-2.

Table 4-2. Maximum Input

Function	Range	Maximum Input
DCV	All	1200VDC or Peak AC
ACV	All	1000V rms sine or DC, $2 \times 10^7 \text{V} \cdot \text{Hz}$
Ohms	All	360V peak or 250V rms

4.4 ZERO

The Zero control serves as a baseline suppression subtracting a stored offset or measured value from a subsequent measurement. When the Zero control is enabled, the Zero LED will light. All readings displayed while in the Zero mode are the difference between the stored baseline and the actual voltage level. The baseline obtained while the Zero control is enabled represents a specific level or quantity of volts or ohms. For example, if 100mV is zeroed, then, 100mVDC represents the specific level of the Zero baseline. One hundred millivolts will then be automatically subtracted from readings on any DCV range. The value for the

baseline can be as little as a few microvolts or as large as 999 volts. This capacity enables the user to zero a wide range of voltages. For example:

	Displayed Offset	Push Zero	Apply Input	Displayed Result
Example #1	1.23000	.00000	1.00000	-.23000
Example #2	.23000	.00000	1.00000	.77000

Note

Setting range lower than the zero baseline value, will overrange display.

WARNING

The voltage present on the input may be greater than the displayed reading when the instrument is Zeroed.

Example: 100V = stored baseline
 150V = actual voltage to be measured
 50V = displayed reading

One baseline can be stored for each of the functions (DC Volts, AC Volts, and Ohms). For example, 20mVDC can be stored for DC volts, 10VAC volts and 5Ω can be stored for ohms. Proceed as follows:

1. To store a zero value for DC volts, select the DC Volts function. Press the ZERO Button. The reading on the Model 192 display will be stored as the zero value. The zero control can be disabled by pressing the ZERO button again.
2. To store a zero value for AC volts, select the AC volts function. Press the Zero button. The reading on the Model 192 display will be stored as the zero value. The zero control can be disabled by pressing the ZERO button again.
3. To store a zero value for Ohms, select the Ohms function. Press the ZERO button. The reading on the Model 192 display will be stored as the zero value. The zero control can be disabled by pressing the ZERO button again.
4. The Model 192 will retain these zero values. If the function is changed the Model 192 will recall the value of zero that was set for that function. To replace an earlier stored zero value, simply press the ZERO button twice. The reading that was on the Model 192 will be stored as the new zero value.

It is important to note that the use of zero reduces the dynamic range of measurement. For instance, if +1.00000VDC is the zeroed value, input voltages greater than 2V would still overload the A/D converter (200,000 counts), even though overrange would occur at approximately 100,000 counts displayed. Readings less than -1V would cause overrange (2V less than +1V) because of the maximum display reading of 199,999 counts. This reduction in the dynamic range of the measurement is illustrated in Figure 4-1. In DCV function, both the Display dynamic range and the Input dynamic range can be exceeded and thus, both can limit the dynamic range of the measurement.

4.5 OVERRANGE INDICATION

Overrange is indicated by the following display:

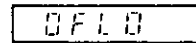

If the overflow is negative then a minus (-) prefix will precede the displayed OFLO.

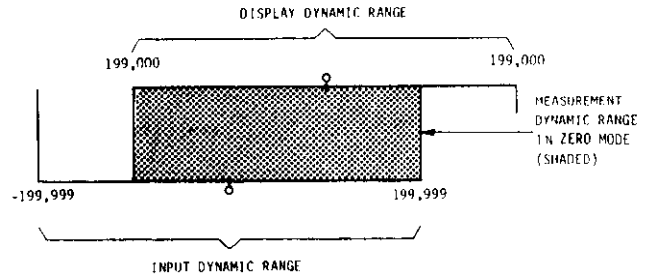

Figure 4-1. Effect of Zero Function on Dynamic Range of Measurement

4.6 FILTER

The Model 192 employs digital filtering techniques. There are three internal filter routines. Figure 4-2 shows the filter response curves. In the Bench mode of operation, the internal computer automatically selects the filter. Filter 1 is selected on 5½ digit readings and filter 2 on 6½ digit readings.

An exception to this is a 20 digit window selected on the 20MΩ range in the 5½ digit mode of operation. In the 6½ mode a 60 digit window (filter 2) is selected, similar to other 6½ digit modes.

When a large input change is sensed, the microprocessor disables the digital filter. This permits a fast response to the input (as noted by A in Figure 4-2). When the reading nears its final value, the filter is turned on (as noted by B in Figure 4-2). This permits low noise settling to the final value.

A third filter, filter 3, is available through the front panel program number two. Filter routines 1, 2, and 3 can be programmed through the IEEE programming option. Refer to the IEEE-488 Instruction Manual for Bus operation.

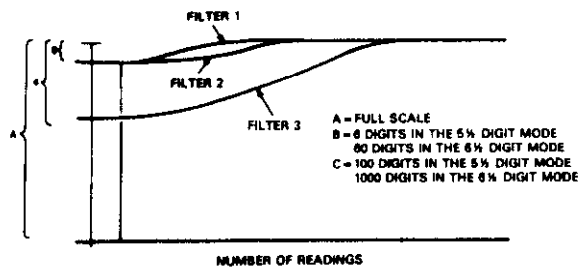

Figure 4-2. Input Filter Response Graph

4.7 DC VOLTAGE MEASUREMENT

The Model 192 reads DC voltage from $1\mu\text{V}$ to 1200V. DC volts are measured as follows:

CAUTION

Do not exceed the 1200VDC maximum allowable input voltage rating. Instrument damage may occur.

1. Turn power ON by pressing the POWER ON/OFF button. If the instrument is within 0°C to 50°C , it is useable immediately, but a two hour warmup is required to obtain rated accuracy.
2. Press DCV button. The Model 192 will enter the DCV mode automatically at power up.
3. Zero instrument on the .2V range. Zero must be set with the Zero function for rated accuracy. Zeroing is necessary to compensate for thermal EMFs generated by the connections to the circuit to be measured. These voltages may be only a few microvolts or several tens of microvolts. Set Zero as follows:
 - A. Set the output of test circuit for zero volts or disconnect the test leads at the circuit and short them.
 - B. Set the Model 192 on the .2V range.
 - C. Press the ZERO button.
 - D. Select range from the five ranges available. The decimal point is positioned by the Range button. The 1200V range is selected by the 2000 button. If the 20M Ω is inadvertently pressed when in the DCV function, the Model 192 will set the range to 1200V.

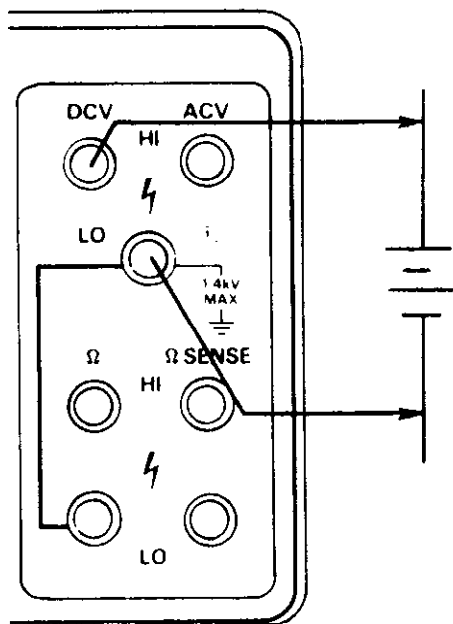

INPUT IMPEDANCE: 1000M Ω on 2V-20V ranges
10M Ω on 200V-1200V ranges

Figure 4-3. DC Voltage Measurements

4. Connect input between the DCV and LO (see figure 4-3). The binding posts accept wires, spade lugs, or banana plugs for ease of connecting the potential to be measured. Low thermal cabling and connections are recommended for measurements on the .2V range.

CAUTION

Do not exceed the 1200VDC maximum allowable input voltage rating. Instrument damage may occur.

5. Take readings by observing the displayed digits and decimal point locations. All ranges are direct reading in volts.

4.8 RESISTANCE MEASUREMENTS

The Model 192 DMM measures resistance from $1\text{m}\Omega/\text{digit}$ to 20M Ω . The Model 192 provides automatic 2-wire or 4-wire ohms operation (see paragraph 4.9 for 4-wire ohms measurements). Measure resistance as follows:

1. Turn on power by pressing the POWER ON/OFF button.
2. Press k Ω button.
3. Select range from the six ranges available (or autorange). The decimal point is positioned by the Range button.
4. Connect input between Ω and LO (see Figure 4-4).
5. Accomplish Zero for a 2-wire or 4-wire measurement on the .2k Ω range. Zero must be set with the Zero function to obtain rated accuracy. Zeroing is necessary to compensate for test lead resistance on 2-wire measurements and for thermal EMFs on 2- and 4-wire measurements. Set Zero as follows:
 - A. Disconnect the test leads at the circuit to be measured and short them.
 - B. Press the "ZERO" button.
 - C. Reconnect the test leads.
6. Take reading.

CAUTION

Maximum allowable input voltage (all ohms ranges): 360V peak, 250V rms. Do not exceed maximum voltage. Instrument damage may occur. Table 4-3 lists the maximum outputs for all the resistance ranges.

Table 4-3. Resistance Ranges

Range Setting	Maximum Outputs*	
	I (Shorted)	V (Open)
.2k**	-4.0mA	-.4V
2k	-4.0mA	-4V
20k	-400 μA	-4V
200k	-40 μA	-4V
2000k	-4.0 μA	-4V
20M	-.40 μA	-4V

* HI binding post (red) is negative.

** Zero must be set to obtain rated accuracy.

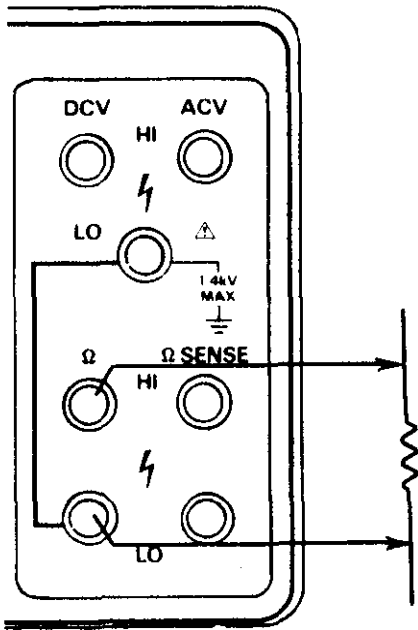

Figure 4-4. Resistance Measurements

4.9 FOUR-WIRE OHMS MEASUREMENT

For 4-wire measurements, connect the sense leads to the circuit to be measured and to the Ω SENSE terminals on the Model 192 (see Figure 4-5). This arrangement eliminates the error due to the voltage drop across the current-carrying leads. Accurate, high resolution ohms measurements are obtained using 4-wire connections.

Four-wire ohms measurements are recommended when utilizing the .2k, 2k, or 20k Ω range. Maximum test lead resistance for 4-wire ohms measurement is given in table 4-4.

Table 4-4. Maximum Four-Wire Test Lead Resistance

Range	Lead Resistance*
.2k	7 Ω
2k	22 Ω
20k	70 Ω
200k	220 Ω
2000k	700 Ω
20M	2200 Ω

*Maximum resistance per lead for an additional 1 digit error at 5 1/2 digits.

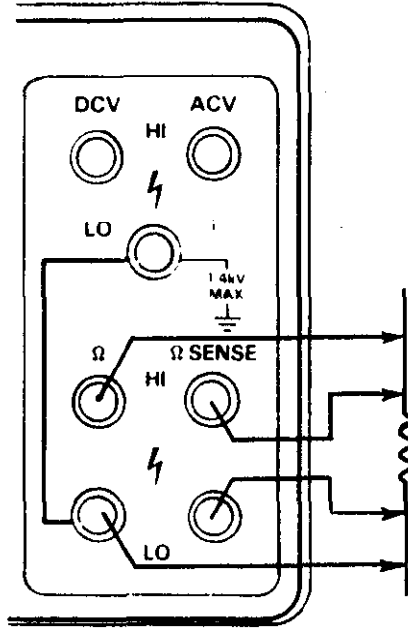
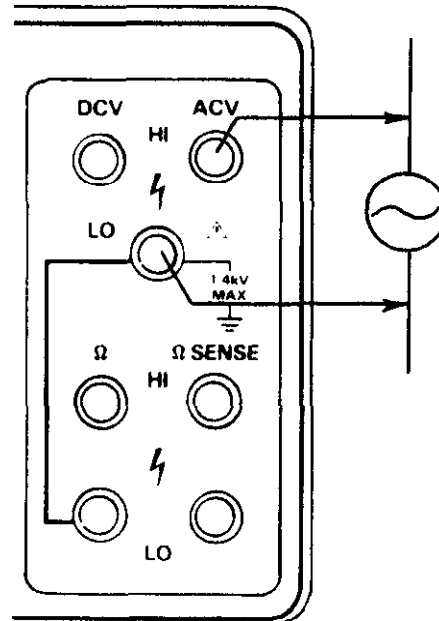

Figure 4-5. Four-Wire Resistance Measurement

4.10 AC VOLTAGE MEASUREMENT (1910 AC Option)

With the Model 1910 option, the Model 192 reads AC voltages from 10 μ V digit to 1000V. The instrument is average responding and is calibrated to the root mean square value of a sine wave, with a frequency span of 20Hz to 100kHz.



INPUT IMPEDANCE: 2M Ω shunted by less than 50pF

Figure 4-6. AC Voltage Measurements

CAUTION

Do not exceed maximum allowable input voltage. Instrument damage may occur. Maximum input is both the voltage and voltage hertz product. If maximum ratings are exceeded, instrument damage will occur.

It is recommended that measurements greater than 150 volts and 20kHz be made in the Manual ranging mode to prevent autoranging to an incorrect range. This is due to the decreased accuracy specified above 20kHz.

Accuracy is specified for 1000 counts and above. The maximum reading is 199999 at 5½ digits. Overrange is indicated by OFLO. Maximum allowable input is 1000V rms or DC; $2 \times 10^7 \text{V} \cdot \text{Hz}$. Measure AC voltage as follows:

1. Turn power ON by pressing POWER ON/OFF button.
2. Press ACV button.

NOTE

The Model 192 will display "NO AC" if AC is selected without an AC option installed.

3. Select range from the four ranges available. The decimal point is positioned by the Range button. The 1000V range (750V range if the Model 1920 is intalled) is selected with the 2000 button. If the 20M Ω button is inadvertently pressed when in ACV function, the Model 192 will set the range to 1000V.
4. Zero OFF unless measurements are to be made as deviations from a preset value.

NOTE

Do not use the ZERO button to zero the AC function. A small residual voltage is normal (approxiamtely 200 μV). If ZERO is used, the reading will be low by the amplitude of the zeroed residual voltage.

5. Connect input to be measured between the ACV and LO binding posts (see Figure 4-6).
6. Take reading.

4.11 AC VOLTAGE MEASUREMENT (1920 TRMS Option)

A separate manual is provided with the Model 1920 containing installation, operation and calibration instructions.

SECTION 5 FRONT PANEL PROGRAMS

5.1 INTRODUCTION

This section contains information and instructions necessary for operating the nine internal programs of the Model 192. These programs are run by depressing the front panel PRGM button, along with the button representing the appropriate program number. Some of the programs require numerical constants that must be entered from the front panel by using the numbered buttons. Other programs will display appropriate messages. Program examples are provided when necessary to instruct the operator in practical applications. For basic operation of the front panel buttons, refer to Section 4. The programs, which are summarized in Table 5-1, are explained in detail in the following paragraphs. Refer to Figure 5-1 for front panel details.

5.2 PROGRAM NOTES

1. Most of the front panel buttons serve a dual purpose. The Range, Function, and Zero buttons are numbered in sequence. These numbered buttons are used when a program number or numerical constant is to be entered.
2. Each program is entered by depressing the PRGM button followed by the desired program number.
3. PROGRAM $\cancel{0}$ is used to cancel all other programs except PROGRAMS 1 and 2. An appropriate clear message is displayed when this program is entered.
4. PROGRAM 1, which controls the display resolution, and PROGRAM 2, which controls the internal filter, may both be used with any other program.
5. PROGRAMS 3 through 7 are mutually exclusive; only one of these programs may be used at any one time.
6. New programs may be entered without clearing a program that is presently running. To do so, depress the PRGM button, followed by the desired program number.
7. Attempting to enter an invalid program number will result in the following error message:

n o p r a
8. The numerical constants used for each program are stored separately and will not change unless entered at the appropriate point in each program. Constant values will be lost if the power is turned off.
9. Constants are to be entered when the operator is prompted to do so by the instrument. When entering a numerical constant:
 - A. The constant is entered by depressing the numbered buttons in the desired sequence.
 - B. The decimal point is automatically placed in accordance with the allowable range of the constant.
 - C. Data is entered into the digit whose "c" segment is flashing by pressing the desired numbered button. The "c" segment of a display digit is shown below:

$\text{8} - \text{"c" segment}$
 - D. Only a 0 or 1 may be entered as the first digit for any of the constants.

Table 5-1. Front Panel Program Summary

Program Number	Operation	Required Constant
0	Clears PROGRAMS 3-7	None
1	Display Resolution	None
2	Filter Mode	None
3	Offset/Scale	S (scaling factor) b (offset)
4	Percent Deviation	n (comparison constant)
5	Min/Max	None
6	High/Low/Pass	LOL (low limit) HIL (high limit)
7	Data Logger	r (time interval)
8	Service*	None

*The Service Program is intended for use only by qualified personnel. See Section 8 of this manual for complete details.

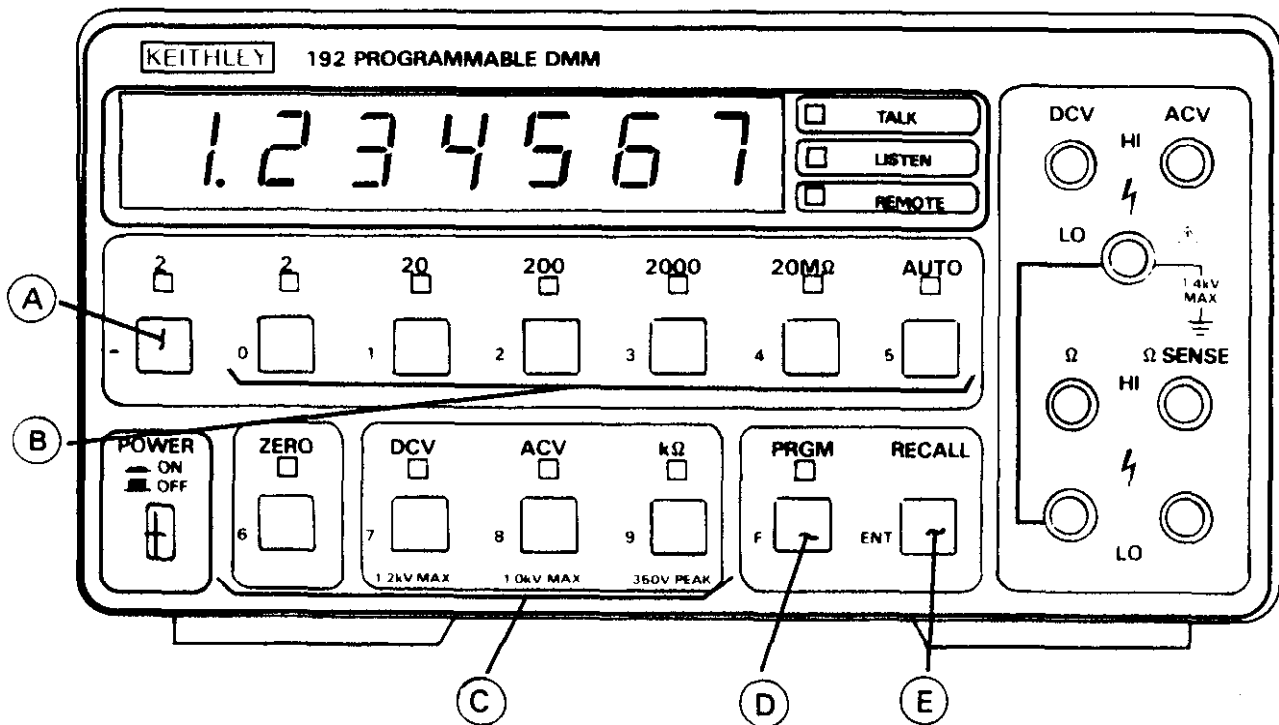

- A MINUS (-)
- B NUMBERS 0 THROUGH 5
- C NUMBERS 6 THROUGH 9
- D PRGM
- E ENT/RECALL

Figure 5-1. Front Panel Program Buttons

- E. Only as many significant digits as necessary need to be entered. The Model 192 will complete the constant with trailing zeroes where necessary.
 - F. Invalid keys will be ignored. If an invalid key is depressed, the blinking "c" segment will remain at the current digit.
 - G. If an incorrect digit is entered, the complete constant must be reentered. The new value may be entered by cycling the display around to the beginning by repeatedly depressing one of the number buttons.
 - H. A negative constant may be entered by depressing the front panel minus (-) button. The display will then show a negative number. This may be done at any point in the numeric input sequence. Depressing the minus button a second time will restore the constant to a positive value.
 - I. If too many digits are entered, the display will begin again at the first digit on the left. All the digits in the constant must then be entered again.
 - J. Once all the digits of the desired constant are shown on the display, the constant is entered into the program by depressing the front panel ENT button.
 - K. The number of significant digits to be entered for a constant will depend on the display resolution mode in use. In the 5 ½ digit mode, only five digits after the leading 0 or 1 may be entered. In the 6 ½ mode, up to six digits in addition to the leading 0 or 1 may be entered.
10. PROGRAMS 3 through 7 will be terminated if the Model 192 receives a Remote Enable command over the IEEE-488 bus. PROGRAMS 0 through 2 are not affected by the Remote Enable command.

Note

If it becomes necessary to exit a program in progress (for example, to change resolution with PROGRAM 1, or change the filter mode with PROGRAM 2), readings will be missed while the instrument waits for the operator to enter the desired program number.

11. When the front panel PRGM button is pressed, the instrument will prompt the operator to enter the desired program number by displaying the following message:

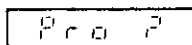

Note that the question mark on the display will blink until a program number is entered. Depressing an invalid button at this point will result in the following message, which will be displayed for ½ second:

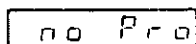

12. The Range, Function, and Zero buttons are locked out while PROGRAMS 3 through 7 are in progress. The operator must exit the program if these parameters are to be changed. If an invalid key is pressed during a pro-

gram, the following message will be displayed for ½ second:

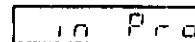

13. While PROGRAMS 3 through 7 are being run, the front panel PRGM indicator light will be on. This light will go off if the program is cancelled, either by using PROGRAM 0, or if the Remote Enable command is received over the IEEE-488 bus.
14. The front panel PRGM button will be inoperative if the IEEE REMOTE indicator light is on. Once the instrument is in the Remote mode, the following IEEE command sequence must be sent to restore front panel programming operation: GTL (Go to Local); DCL (Device Clear). For more information on IEEE commands, refer to the Model 1923 Instruction Manual. Alternately, the instrument may be turned off and then powered-up again to restore programming operation. Of course, any constants previously stored will be lost, and the instrument will return to the power-on default conditions.
15. When PROGRAMS 3 through 7 are entered, the AUTO range will be cancelled. The instrument will stay on the present range when one of these programs is entered.

5.3 PROGRAM 0. CLEAR

PROGRAM 0 may be used to cancel PROGRAMS 3 through 7. This program is entered by depressing the PRGM switch followed by the 0 button as follows:

1. Press PRGM. The instrument will display the following, indicating it is waiting for a program number:

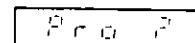

2. Press 0. The following message will be displayed for approximately ½ second:

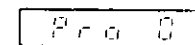

3. Immediately following the program number indication, the following message will be displayed for ½ second:

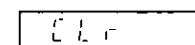

4. PROGRAMS 3 through 7 will be cancelled, and the Model 192 will return to the normal operating mode by displaying readings. The operation of the Function, Range, and Zero buttons will be restored after PROGRAM 0 is entered.

5. Depressing the RECALL button after PROGRAM 0 has been run will cause the following message to be displayed for ½ second:

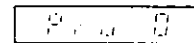

5.4 PROGRAM 1. RESOLUTION

The display resolution of the Model 192 may be changed to 5½ or 6½ digits by running PROGRAM 1. It has no effect on the data transmitted over the IEEE-488 bus, and may be used with PROGRAMS 3 through 7. Each time PROGRAM 1 is entered, the instrument will change display resolution modes. Upon power-up, the instrument is in the 5½ digit display mode. To change the resolution, PROGRAM 1 may be entered as follows:

1. Press PRGM. The Model 192 will respond with the usual prompt for a program number as follows:

2. Press 1. The unit will indicate it has entered PROGRAM 1 by displaying the following message for ½ second:

3. If the instrument was previously in the 5½ digit mode, it will change to the 6½ digit mode as indicated by the following message, which will be displayed for approximately ½ second:

Readings made in the 6½ digit mode are made at a slower rate, as indicated by the flashing rate of the decimal point.

4. If the instrument was previously in the 6½ digit mode, it will change to the 5½ digit mode and display the following message for ½ second:

5. After PROGRAM 1 has been run, the Model 192 will continue to display normal readings. PROGRAMS 3 through 7 may be entered at this time without affecting display resolution.

6. Example: Assume the Model 192 is connected to a DC voltage source and is in the 5½ digit mode on the 20V range. A typical 5½ digit display reading might be:

After entering PROGRAM 1, the display reading might change to:

Note that the last digit was rounded off when the instrument was in the 5½ digit display mode.

5.5 PROGRAM 2. FILTER

The Model 192 has a digital filter that is useful for minimizing the effects of noise on the readings. Normally, filter 1 is enabled for the 5½ digit resolution mode, while filter 2 is

normally enabled for the 6½ digit mode. For a more complete description of these routines, refer to paragraph 4.6.

PROGRAM 2 controls operation of a third available filter, filter 3. Each time PROGRAM 2 is entered, the state of filter 3 is changed. If filter 3 was previously enabled, entering PROGRAM 2 will turn filter 3 off. If the filter was previously disabled, PROGRAM 2 will turn the filter on. Upon power-up, filter 3 is disabled. The mode of filter 3 may be changed by entering PROGRAM 2 as follows:

1. Press PRGM. The instrument will respond with the usual prompt for a program number:

2. Press 2. The program will be entered as indicated by the following message which will be displayed for ½ second:

3. If the filter was previously turned off, the filter will be enabled, and the following message will be displayed for ½ second:

4. If the filter was on, it will be disabled, and the following message will be displayed for approximately ½ second:

NOTE

If the filter is not in the desired mode, it may be changed by running PROGRAM 2 again. To do this, simply depress the PRGM and 2 buttons in sequence a second time. Each time PROGRAM 2 is entered, the filter mode changes to the alternate state.

5. Once PROGRAM 2 has been entered, the Model 192 continues normal operation by displaying readings. Other programs may then be entered as desired.

6. As an example of PROGRAM 2 operation, assume that readings on the 0.2VDC range are being made. If the displayed readings continuously or intermittently hop around, the filter should be turned on to minimize these effects. Note that operating the Model 192 with the filter on will increase the response time to sudden changes in input level; if short settling times are required, the operator should use PROGRAM 2 to disable the filter. See figure 4-2 for the response graph of filter 3.

5.6 PROGRAM 3. OFFSET/SCALE

PROGRAM 3 allows the operator to automatically multiply normal display readings (X) by a constant (S) and add an offset (b). The result (Y) will be displayed in accordance with the formula, $Y = SX + b$. Upon power up, $S = 1$, and

b = 0, but these constants may be changed at the appropriate point in the program. Note that Range, Function, and Zero buttons are inoperative during the course of the program. If one of these buttons is depressed while PROGRAM 3 is running, an "in Pro" message will be displayed. PROGRAM 3 is useful when slope calculations are required for a series of measurements. Operating instructions for PROGRAM 3 are as follows:

1. Select the Function and Range, and enable the Zero, if desired, before PROGRAM 3 is entered. These operating controls cannot be used once the program is run.
2. Press PRGM. The Model 192 will respond with the program prompt message as follows:

P r o 3

3. Press 3. The program number will be displayed for ½ second as follows:

P r o 3

4. The instrument will now prompt the operator to enter the S constant by displaying the following message for ½ second:

S : r²

5. The old value of S will then be displayed; the most significant digit will show a blinking "c" segment to indicate that an operator entry is required. If no changes in the displayed value are desired, the constant may be entered by depressing the ENT button.
6. A new value for S may be entered by depressing the numbered buttons in the desired sequence. Note that S must be in the range $-1.999999 \leq S \leq +1.999999$. After the desired value of S is shown on the display, the constant must be entered into the program by depressing the front panel ENT button.
7. After the S constant is entered, the Model 192 will prompt the operator to enter the b constant by displaying the following message for ½ second:

b : r²

8. The display will then show the presently stored value of b. In addition, the first digit "c" segment will blink, indicating the instrument is waiting for an input. At this point, the old value of b may be entered simply by depressing the ENT button.
9. A new value for b may be entered by depressing the numbered buttons in the desired sequence. Note that the b must be in the range of $-1999999 < b < +1999999$ with the decimal point automatically placed according to range. For a given range, the value of b cannot exceed the maximum that can be measured on that particular range. For example, the maximum value of b on the 20VDC range is ± 19.99999 . Once the desired constant is shown on the display, it may be entered into the program with the ENT button.

10. Once the ENT button has been depressed, the Model 192 will show the value of Y. If the value of Y is larger than can be handled by the particular range, an "OFLO" message will be displayed, indicating the instrument must be switched to a higher range. Note that PROGRAM 3 must be cancelled with PROGRAM 0 before the range can be changed.
11. While still in PROGRAM 3, new values for S and b may be entered by using the RECALL button. The following message will be displayed for ½ second:

P r o 3

The Model 192 will then prompt for new values of S and b as previously described. To enter new values, follow the procedure in steps 5 through 9 of paragraph 5.6.

12. The values for S and b will be stored within the Model 192 until the power is turned off. These constants may be used in future runs of PROGRAM 3. Note, however, that the value of b is scaled according to the range in use. If, for example, a value of 19.00000 was entered for b with the instrument on the 20V range, the value of b will be changed to 190.0000 if the program is entered with the instrument on the 200V range.
13. An example of readings that will be obtained when PROGRAM 3 is run is shown in the following. Each of the obtained values for Y assumes the following constants: S = +1.5; b = +5. Also, the instrument is on the 20 (DCV, ACV, kΩ) range.

Normal Reading	PROGRAM 3 Reading (Y = SX + b)
+8 VDC	+17 VDC
-5 VDC	-2.5 VDC
6.3 VAC*	14.45 VAC
4kΩ	11 kΩ

*Requires AC Option

NOTE

The display resolution mode determines the number of digits required for the b and S constants. The range and example values given assumes the Model 192 is being operated in the 6½ digit mode. One less digit is required for these constants when in the 5½ digit mode.

5.7 PROGRAM 4. PERCENT DEVIATION

This program allows the user to determine how much a particular reading differs from some desired value. The percent deviation is internally computed according to the following formula:

$$Y = \frac{X-n}{n} \times 100$$

where X is the normal reading, Y is the percent deviation, and n is the constant to which the reading is to be compared. Upon power-up, n=0 and must be changed by the operator or the instrument will go into overflow when the program is run. Note that the Range, Function, and Zero buttons are inoperative when in this program; the program must be cancelled if these parameters must be changed. The basic procedure for using PROGRAM 4 is as follows:

1. Select the Function and Range, and Zero the instrument, if desired, before entering the program.
2. Press PRGM. The instrument will display:

Pr o 2

3. Press 4. The program message will be displayed for ½ second as follows:

Pr o 4

4. The instrument will prompt the operator to enter the constant n for ½ second as follows:

n = 2

5. The present value of n will then be displayed. At this point, some constant must be entered if the present value of n=0, or an overflow will occur. If the present value of n is not zero, the ENT button may be used to enter the presently displayed value of n into the program.
6. If a new value of n is desired, enter the number one digit at a time into the display. The value of n must lie in the range of $-1999999 \leq n \leq +1999999$. Note that the decimal point will automatically be placed according to range. The value of n cannot be greater than the range currently being used. For example, the maximum value of n on the 200VAC range is 199.9999. Also, the number of digits in the constant depends on the display resolution. In the 5½ digit mode, one less digit will appear in the constant.
7. Once the desired constant is in the display, the value may be entered into the program with the ENT button.
8. Once n is entered, the display will show the percent deviation within the range of $-199.9999 \leq Y \leq +199.9999$. Once again, the actual number of digits will depend on the display resolution; the least significant digit will be rounded off in the 5½ digit mode.
9. If the range of the instrument is exceeded on the percent deviation computation, the Model 192 will display its "OFLO" message.
10. A new value for n may be entered without exiting the program by pressing the RECALL button. The instrument will respond with:

Pr o 4

for ½ second, followed by:

n = 2

11. As an example of how the Model 192 computes percent deviation, assume that the display shows a reading of +150V (X) on the 200VDC range and the value for comparison (n) is +125V. The percent deviation Y will be automatically computed by the instrument when PROGRAM 4 is entered after the value of n (in this case +125) is entered, as follows:

$$Y = \frac{X-n}{n} \times 100$$

$$Y = \frac{150-125}{125} \times 100$$

$$Y = 20\%$$

In this example, the percent deviation is positive because the measured voltage (X) is more positive than the comparison standard (n). If the percent deviation shown in the display should have a negative value, then the measured voltage is more negative than the programmed constant.

5.8 PROGRAM 5. MIN/MAX

PROGRAM 5 allows the operator to automatically store the minimum and maximum readings that occur while the program is being run. An example of an application for this program might be to monitor the output voltage of a new power supply design to see how much it drifts over a given period of time.

Operating instructions for PROGRAM 5 are as follows:

1. Select the Function and Range, and Zero the instrument, if desired, before entering the program. These parameters cannot be changed once the program has been entered.
2. Press PRGM to obtain the following prompt:

Pr o 2

3. Press 5. The instrument will display the program number for ½ second as follows:

Pr o 5

4. Immediately following the program number, the following message will be displayed for ½ second:

HI-LO

5. The display will continue to show the present reading. Minimum and maximum readings are automatically stored for recall. The stored data always contains 6½ digits even if the storage was made while the unit is in

the 5½ digit mode. Thus, 6½ digit resolution may be obtained for the high and low readings regardless of the display resolution. To obtain 6½ digit resolution for recalled readings, the instrument must be in the 6½ digit mode.

- To display the high and low readings, depress the RECALL button; the instrument will display the following for ½ second:

Pr o 5

- Following the program number, the following will be displayed for ½ second:

L O

This message will be followed by the low reading itself.

- To obtain the high reading, depress the RECALL button again. The instrument will respond with:

H I

for a period of ½ second, after which the display will show the highest reading obtained during the current PROGRAM 5 run.

NOTE

The low or high reading sequences will be cancelled if the operator attempts to run PROGRAM 1 or 2 while reading back low and high values.

- To continue the program with the current high and low values, press ENT. The instrument will begin at step 5, paragraph 5.8.
- To continue with new high and low values, the program must be entered from the beginning at step 2 of paragraph 5.8.
- As an example of PROGRAM 5 operation, assume the Model 192 is to be used to monitor the drift of a +12VDC (nominal) power supply over an eight hour period. Once the instrument is connected to the supply, the operator would then set the unit for 20VDC operation with the appropriate front panel buttons. The filter, resolution, and Zero modes, may be selected as desired.

To begin the program, the user depresses the PRGM and 5 buttons in sequence; the Model 192 then begins storing maximum and minimum values. Assume the power supply voltage actually drifted as shown in the following:

Elapsed Time	Actual Voltage
0	+ 12.006V
1 hr.	+ 12.01V
2 hr.	+ 12V
3 hr.	+ 11.99V
4 hr.	+ 11.987V
5 hr.	+ 11.95V
6 hr.	+ 12V
7 hr.	+ 12.001V
8 hr.	+ 12.005V

At the end of the prescribed time period, the operator could check for low and high values by depressing the RECALL button. The low value, which will be displayed immediately after the "LO" message, is +11.95V while the high value for this example is +12.010V. To continue the test with the existing high and low values, the operator must press the ENT button. To enter new high and low values, the program must be started from the beginning.

5.9 PROGRAM 6. HI/LO/PASS

PROGRAM 6 allows the operator to set low and high reading limits into memory. Once the limits are set, the Model 192 will indicate whether or not a specific reading falls within the prescribed range. This feature is especially useful for component evaluation, where certain component tolerances must be observed. Once the limits are programmed into the instrument, the operator need only watch for the appropriate message on the display to determine if a particular component is within tolerance. With the optional Model 1923 IEEE-488 interface installed, the Model 192 may be used to control sorting and handling equipment with suitable relays. Operating instructions for PROGRAM 6 are as follows:

- Select the desired Function and Range, and Zero the instrument, if desired, before entering the program. These parameters cannot be changed once the program is run.
- Press PRGM. The following message should be displayed:

Pr o 6

- Press 6. The instrument will display the program number for ½ second:

Pr o 6

- Immediately following the program number, the instrument will prompt for the low reading limit with the following message for ½ second:

L O L i m i t

5. At this point, the display will show the old value. If the displayed value is to be used, press the ENT button.
6. If a new value is to be entered, press the numbered buttons in sequence. The low value must be in the range $-1999999 < LOL = \underline{\quad} + 1999999$; the decimal point will be placed according to range. Note that the low value cannot be numerically larger than the limits of the range being used.
7. Once the desired value is shown on the display, press ENT to enter the low limit.
8. The instrument will now prompt for the high limit by displaying the following message for ½ second:

H I L : $\bar{\quad}$

9. The old high limit will be displayed, and may be entered by simply pressing the ENT button at this point. Note that the high limit must be more positive than the low limit, or the program will not run.
10. To enter a new high limit, use the numbered buttons in the desired sequence. The value must be in the range of $-1999999 < H I L \leq + 1999999$, with the decimal point placed according to range. As with the LOL constant, the high limit constant cannot have a value larger than the limits of the range in use. Once the desired value is in the display, press the ENT button to enter the constant.
11. At this point, the instrument will run the program. No numeric readings will be displayed, but the instrument will show one of the following messages, depending on the measurement.
 - A. If the measured value is less than the low limit, then "LO" will be displayed.
 - B. If the measured value is greater than the high limit, then "HI" will be displayed.
 - C. If the measured value falls within the low and high limits, then "PASS" will be displayed.
12. To enter new low and high values, press the RECALL button and begin at step 4 of paragraph 5.9.
13. As an example of PROGRAM 6 operation, assume that a batch of 10k Ω , 10% resistors must be checked for tolerance. Before running the program, the operator would place the Model 192 on the 20k Ω range to make the necessary measurements. Then PROGRAM 6 is run by depressing the PRGM and 6 buttons in sequence. When the instrument prompts for the low value, the operator would key in 9.000 (10k Ω -10%). When the high limit is asked for, a value of 11.000 is entered (10k Ω + 10%). When the program is run, the instrument will show the "PASS" message for all resistors that fall within the 10% tolerance range. For those resistors with values under 9k Ω , the instrument will show a "LO" message, while resistors greater than 11k Ω , will cause the "HI" message to be displayed.
14. Three open collector outputs for HI, LO, and PASS, are available on the IEEE card. These outputs may be used

with relays to control other equipment. For further details, consult the Model 1923 Instruction Manual.

5.10 PROGRAM 7. DATA LOGGER

PROGRAM 7 is designed to allow the operator to store up to 100 readings in an internal buffer. The reading intervals may be set to specific values between 0.11 seconds and one hour. At any point in the program, readings may be recalled from the front panel. This program is useful for such applications as the long term monitoring of the operation of a system. Once the data points are stored, the readings may be recalled to determine if the system operated in the HI/LO limits over the specified period. The operation of PROGRAM 7 is as follows:

1. Select the Function and Range, and Zero the instrument, if desired. These parameters cannot be changed once the program is entered.
2. Press PRGM. The following message will be displayed:

P r o g 7

3. Press 7. The program number will be displayed for ½ second:

P r o 7

4. The instrument will now prompt the operator to input the time interval constant r , by displaying the following message for ½ second:

r : $\bar{\quad}$

5. The display will then show the current value of r . Each digit corresponds to a given time interval as listed in Table 5-2. Also shown is the total time required to store 100 readings. Upon power-up, $r=0$, corresponding to a time interval of 0.11 seconds for 60Hz operation.
6. To enter the old value of r , press the ENT button.
7. A new value r may be entered by depressing the appropriate number button. Once the desired digit is shown in the display, the value will be entered into the program by pressing the ENT button.
8. At this point, the Model 192 will not yet begin to store readings; instead, present readings will be displayed, with the following message appearing every few seconds.

E n t e r

9. To actually begin storing readings, press the ENT button again. The instrument will respond by logging data points at a time interval determined by the previously programmed value of r .
10. The readings may be retrieved at any time during the logging process by pressing the RECALL button. The

number of the reading will be indicated by the following message:

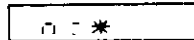

The asterisk represents the number of the reading, which will be displayed for 1/2 second, followed by the reading itself. Note that the decimal point stops flashing when the display shows a recalled reading.

11. After all 100 data points have been logged, the instrument will respond with the following message:

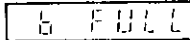

12. Pressing the RECALL button at this point, will display the last reading in the buffer.
13. To continue recalling readings, press the RECALL button momentarily. After the number of each reading is briefly displayed, the reading itself will be shown. If the RECALL button is held in, the reading numbers automatically increment in sequence.
14. To decrement the reading numbers rather than increment them, press the minus (-) button before depressing the RECALL button. The reading number will continue to decrement with each operation of the RECALL button until the minus button is pressed a second time.
15. Logging may be continued if previously interrupted by pressing the 0 and ENT buttons in sequence. The decimal point will again flash. To change the reading time interval or start the program over, exit the program by using the PRGM button and begin at step 3 of paragraph 5.10.
16. As an example of PROGRAM 7 operation, assume it is desired to monitor the power line voltage for a computer system over a given period of time. To do so, the operator would switch the Model 192 to the 200VAC* range and connect the instrument to the power line. Once the program is entered, the operator may choose any time interval listed in Table 5-2. For this example, assume that a time interval of 10 minutes is desired. When prompted to do so, the operator should key in a value of 7 for the constant r. Once the program has run, the Model 192 will log the power line voltage at 10 minute intervals. The instrument may be interrupted at any time to display stored readings. Once all 100 readings are stored the "b FULL" message will be displayed, and the operator may display the readings in sequence with the RECALL button, as previously described.

Table 5-2. Data Point Times

r	t	Total Time For 100 Data Points
0†	.11 sec./ .126 sec.	11 sec. at 60Hz/ 12.6 sec. at 50Hz
1	.5 sec.	50 sec.
2	1 sec.	1 min. 40 sec.
3	5 sec.	8 min. 20 sec.
4	10 sec.	16 min. 40 sec.
5	1 min.	1 hr. 40 min.
6	5 min.	8 hr. 20 min.
7	10 min.	16 hr. 40 min.
8	30 min.	2 days 2 hr.
9	1 hr.	4 days 4 hr.

†Fastest reading rate of each function (DCV, KΩ or ACV).

5.11 IEEE BUFFER OPERATION**

If desired, the data in the buffer may be read by commands given over the IEEE-488 bus. However, controller must not send the IEEE-488 REN (Remote Enable) command, or the Model 192 will exit PROGRAM 7.

If desired, data in the buffer may be fed to an IEEE listener such as a printer. For more complete information on accessing the buffer through the IEEE bus, refer to the Model 1923 Instruction Manual.

5.12 PROGRAM 8. SERVICE PROGRAM

As the name implies, this program is designed to aid in servicing the Model 192. It is not intended for operator use; qualified service personnel should refer to section 8, paragraph 8.4, for a complete description of PROGRAM 8 operation. Should the operator inadvertently enter this program, operation of the instrument may be restored by depressing any front panel button (except POWER) four times in succession.

NOTE

For software level E7 use Program 0 for the service program.

* Requires AC option.

** Requires Model 1923 IEEE-488 option.

SECTION 6 PERFORMANCE VERIFICATION

6.1 INTRODUCTION

Performance verification is recommended upon receipt of the instrument, to ensure that no damage or misadjustment has occurred during transit. Verification may also be performed whenever the instrument's accuracy is questioned or following calibration.

NOTE

For instruments that are still under warranty (less than 12 months since date of shipment), whose performance falls outside specifications at any point, contact your Keithley representative or factory immediately.

6.2 ENVIRONMENTAL CONDITIONS

All measurements should be made at an ambient temperature within the range of 18° to 28°C (65° to 82°F) and a relative humidity of less than 80%.

6.3 RECOMMENDED TEST EQUIPMENT

Recommended test equipment for performance verification is listed in Table 6-1. Alternate test equipment may be used. However, if the accuracy of the alternate test equipment is not at least four times better than the instrument's specifications, additional allowance must be made in the reading's obtained. Some of the equipment listed in Table 6-1 is not four times better than the Model 192 specifications because such equipment is not readily available. In these instances, the verification procedures indicate the equipment manufacturer's specified uncertainty in determining the allowable reading for the Model 192.

Table 6-1. Recommended Test Equipment for Performance Verification

ITEM	DESCRIPTION	SPECIFICATION	MFR.	MODEL
A	DC Calibrator	10V, 100V, 1000V ± 0.002% or 20µV	Fluke	343A
B	AC Calibrator	0.1V, 1V, 10V, 100V ± 0.022%	H-P	745A
C	High Voltage Amplifier (Used with Model 745A)	1000V ± 0.04%	H-P	746A
D	Decade Resistor	190Ω, 1.9kΩ, 19kΩ, 190kΩ, 1.9MΩ, 10MΩ ± 0.01%	ESI	RS725
E	Kelvin-Varley Voltage Divider (Used with Model 343A)	.19V, 1.9V with .2ppm Terminal Linearity	Fluke	720A

6.4 INITIAL CONDITIONS

Before beginning the verification procedures, ensure that the instrument meets the following conditions:

1. If the instrument has been subjected to extremes of temperature, allow sufficient time for internal temperatures to reach normal operating conditions specified in paragraph 6.2. Typically, it takes one hour to stabilize a unit that is 10°C (18°F) out of the specified temperature range.
2. Turn the Model 192 on and allow it to warm up for two hours.

WARNING

This procedure requires high voltage and is intended for use by qualified test personnel only. Take care to prevent contact with live circuits which could cause electrical shock resulting in injury or death.

6.5 PERFORMANCE VERIFICATION

6.5.1 DC Voltage Accuracy Check (20V to 1200V ranges)

1. Select the DC Volts function.
2. Connect the DC calibrator (Item A, Table 6-1) to the Model 192's DCV terminal.
3. Select the 20 range.
4. Apply a positive 10.0000VDC to the Model 192. The reading must be within the limits specified in Table 6-2.
5. Select the 200 range.

- Apply a positive 100.00VDC to the Model 192. The reading must be within the limits specified in Table 6-2.
- Select the 1200 range.

WARNING

The 1200 range will overrange at voltages over 1200V. As specified on the front panel beneath the DCV button, 1.2kV is the maximum allowable voltage that can be applied without damaging the instrument.

- Apply a positive 1000.00VDC to the Model 192. The reading must be within the specified limits in Table 6-2.
- Repeat all checks with negative voltage.

Table 6-2. DC Voltage Performance Check (20V to 1200V Range)

Range	Applied Voltage	Allowable Readings at 18° to 28°C
20V	10.0000V	9.9988 to 10.0012V
200V	100.000V	99.987 to 100.013V
1200V	1000.00V	999.86 to 1000.14V

6.5.2 DC Voltage Accuracy Check (.2V to 2V ranges)

- Select the DC Volts function.
- Select the .2 range.
- Connect the DC calibrator (Item A, Table 6-1), Kelvin-Varley voltage divider (E) and Model 192 as shown in Figure 6-1.
- Set the DC calibrator to an output of +10.0000V. Set the Kelvin-Varley to .019000 (for an output voltage of .190000 volts).
- Dial the Kelvin-Varley voltage divider to zero. Then press the Model 192 ZERO button for a display indication of 00.0000 ± 1 digit.
- Verify that the Model 192 reading is between .189975 and .190025. Note that the allowable reading includes a ± 6 digit allowance for the uncertainty of the DC calibrator and Kelvin-Varley voltage divider.
- Repeat steps 4 through 6 with a negative voltage, and be sure to rezero.
- Select the 2 range. Set the Kelvin-Varley voltage divider to .190000 output. Be sure to rezero.
- Verify that the Model 192 reading is between 1.89981 and 1.90019. Note that the allowable reading includes ± 4 digits for DC calibrator uncertainty.
- Repeat Step 9 with negative voltage. Be sure to rezero.

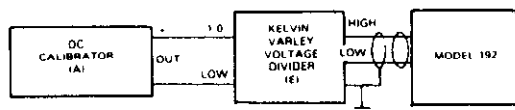

Figure 6-1. Test Circuit .2mV and 2V

6.5.3 AC Voltage Accuracy Check (With Model 1910 AC Voltage Option Installed)

- Select the AC Voltage function.
- Connect the AC calibrator (Item B, Table 6-1) to the Model 192 ACV terminals. Set the AC calibrator to 1kHz.
- Set the Model 192 to the 2 range. Apply 1.00000VAC to the Model 192. Verify that the reading is within the limits specified in Table 6-3.
- Repeat steps 2 and 3 for the 20V range and then 200V range. Apply the required voltages listed in Table 6-3 and verify that the readings are within the limits specified.
- To check the 1000V range, connect the High Voltage Amplifier (Item C) to the output of the AC calibrator per the manufacturer's instructions. Select the 1000V range by pressing the 2000 button of the front panel. Connect the amplifier output to the Model 192 ACV terminals. Set the AC calibrator for an amplifier output of 1000.00V at 1kHz. Verify that the Model 192 reading is within the specified limits in Table 6-3.
- To check accuracy at 50Hz, 20kHz, and 100kHz, select the 20 range, apply the voltage specified in Table 6-3 at 50Hz, then repeat at 20kHz and 100kHz. Verify that the Model 192 readings are within the limits specified.

Table 6-3. AC Voltage Accuracy Check

Range	Applied Voltage	Allowable Readings at 18° to 28°C
2V 20V 200V 1000V	at 1kHz	.99868 to 1.00132V 9.9868 to 10.0132V 99.868 to 100.132V 998.00 to 1002.00V
	1.000V	
	10.000V	
	100.00V	
20V	at 50Hz	9.9868 to 10.0132V
	10.000V	
20V	at 20kHz	9.9868 to 10.0132V
	10.000V	
20V	at 100kHz	9.90 to 10.10V
	10.000V	

For performance verification of TRMS AC volts, refer to the Model 1920 Instruction Manual.

6.5.4 Resistance (Ω) Accuracy Check

- Select resistance (Ω) function.

NOTE

The .2kΩ and 20kΩ range performance verification will be done on four-terminal ohms, that is, utilizing the Ω terminal as well as the Ω sense terminal. For four-terminal measurements, connect the Ω sense leads to

the circuit to be measured and the Ω sense terminals to the Model 192. This arrangement eliminates the error due to the voltage drop across the current-carrying leads. The ZERO button also accomplishes this. It is recommended that both be used to compensate for lead resistance.

2. Perform Zero function as follows:
 - A. Connect the $\Omega(s)$ terminals together (short them) with a low thermal shorting plug.
 - B. Press the ZERO button and verify each $\Omega(s)$ range as specified in Table 6-4.

Table 6-4 Zero Readings

Range	Allowable Reading
.2 k Ω	.00000 \pm 10 digits
2 k Ω	0.0000 \pm 2 digits
20 k Ω	00.000 \pm 2 digits
200 k Ω	000.00 \pm 2 digits
2000 k Ω	0000.0 \pm 2 digits
20M Ω	00.000 \pm 2 digits

3. Select the .2k Ω range.
4. Connect the decade resistor (Item D, Table 6-1) to the Ω terminal and the Ω sense terminals.
5. Set the decade resistor (Item D, Table 6-1) to zero and compensate for any residual lead resistance by pressing the ZERO button for a display indication of .000000 \pm .000001 flashing.

6. Set the decade resistor to 0.190000k Ω . Verify that the reading for the .2k Ω range is within the limits specified in Table 6-5.
7. Select the 2k Ω range.
8. Set the decade resistor to 1.90000k Ω . Verify that the reading is within the limits specified in Table 6-5.
9. Select the 20k Ω range. Set the decade resistor to zero and reset the ZERO button.
10. Set the decade resistor to 19.0000k Ω . Verify that the reading is within the limits specified in Table 6-5.
11. Select the 200k Ω range and remove Ω sense leads. Set the decade resistor to zero and reset the ZERO button.
12. Set the decade resistor to 190.000k Ω . Verify that the reading is within the limits specified in Table 6-5.
13. Select the 2000k Ω range. Set the decade resistor to zero and reset the ZERO button.
14. Set the decade resistor to 1900.00k Ω . Verify that the reading is within the limits specified in Table 6-5.
15. Select the 20M Ω range. Set the decade resistor to zero and reset the ZERO button.
16. Set the decade resistor to 10.0000M Ω . Verify that the reading is within the limits specified in Table 6-5.

Table 6-5 Resistance Accuracy Check

Range	Resistance	Allowable Readings at 18° to 28°C	*
.2 k Ω	.190000k Ω	.189960 to .190040	\pm 19 digits
2 k Ω	1.90000k Ω	1.89960 to 1.90040	\pm 19 digits
20 k Ω	19.0000k Ω	18.9960 to 19.0040	\pm 19 digits
200 k Ω	190.000k Ω	189.960 to 190.040	\pm 19 digits
2000 k Ω	1900.00k Ω	1899.60 to 1900.40	\pm 19 digits
20M Ω	10.0000M Ω	9.9949 to 10.0051	\pm 10 digits

*Manufacturer's specified uncertainty of the decade resistor (D) in digits. This uncertainty has been added to the specified accuracy of the Model 192 to obtain the allowable reading.

SECTION 7 THEORY OF OPERATION

7.1 INTRODUCTION

This section contains circuit descriptions for the Model 192. Descriptions are also included for the Model 1910 AC Option. A separate instruction manual is available for the Model 1920 TRMS option. The information is arranged to provide a description of individual functional circuit blocks. To facilitate understanding, the descriptions are keyed to accompany simplified block diagrams and schematics. Detailed schematics of the Model 192 and Model 1910 are located at the end of this manual.

7.2 OVERALL FUNCTIONAL DESCRIPTION

The Model 192 is a 6 1/2 digit, $\pm 2,000,000$ counts DMM with five DC voltage and six resistance ranges (standard). The unit has $1\mu\text{V}$ and $1\text{m}\Omega$ sensitivity with 0.00005% resolution. When the Model 1910 AC Voltage Option is installed, AC voltages from $10\mu\text{V}$ to 1000V can be measured. The most unique feature of the Model 192 is its' hybrid Analog-to-Digital converter which uses both charge balance and single slope conversion techniques. A microcomputer located within the Model 192 controls the Analog-to-Digital conversion process. The charge balance/single slope converter feature, along with the internal microcomputer, provides many enhancements to the DMM's performance. These enhanced features include:

- Extremely High Accuracy
- High Conversion Speeds
- Quick Settling Times
- Reduction in the number of component parts
- Non-Linear Digital Filtering
- Push button nulling of any on-scale input signal
- Automatic 2/4 Terminal Ohms Measurements

These items will be described in more detail in the latter part of this section. Refer to Figure 7-1 for a simplified signal flow block diagram of the Model 192.

The Model 192 is partitioned into two electrically isolated sections, digital and analog. These sections are isolated by opto isolators and by isolated secondary windings on the power transformer. Partitioning and isolating the unit allows the LO or common input of the DMM's analog section to be placed at any potential (between $\pm 1200\text{V}$). Simultaneously, the LO or common side of the digital circuitry can be maintained at voltage potentials within 30V of chassis ground. This isolation simplifies interfacing of the Model 192 with external digital equipment.

Operation of the Model 192 is centered around the A/D converter. The converter requires a conditioned analog input for the wide range of DC inputs used, and the conversion of ohms and AC voltages to DC voltages. The A/D

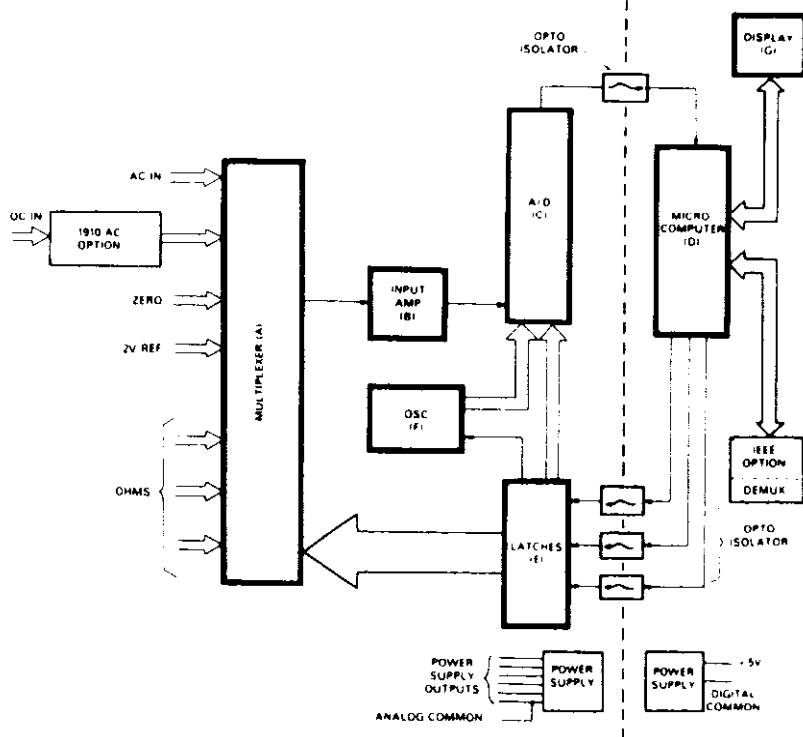

Figure 7-1. Basic Block Diagram

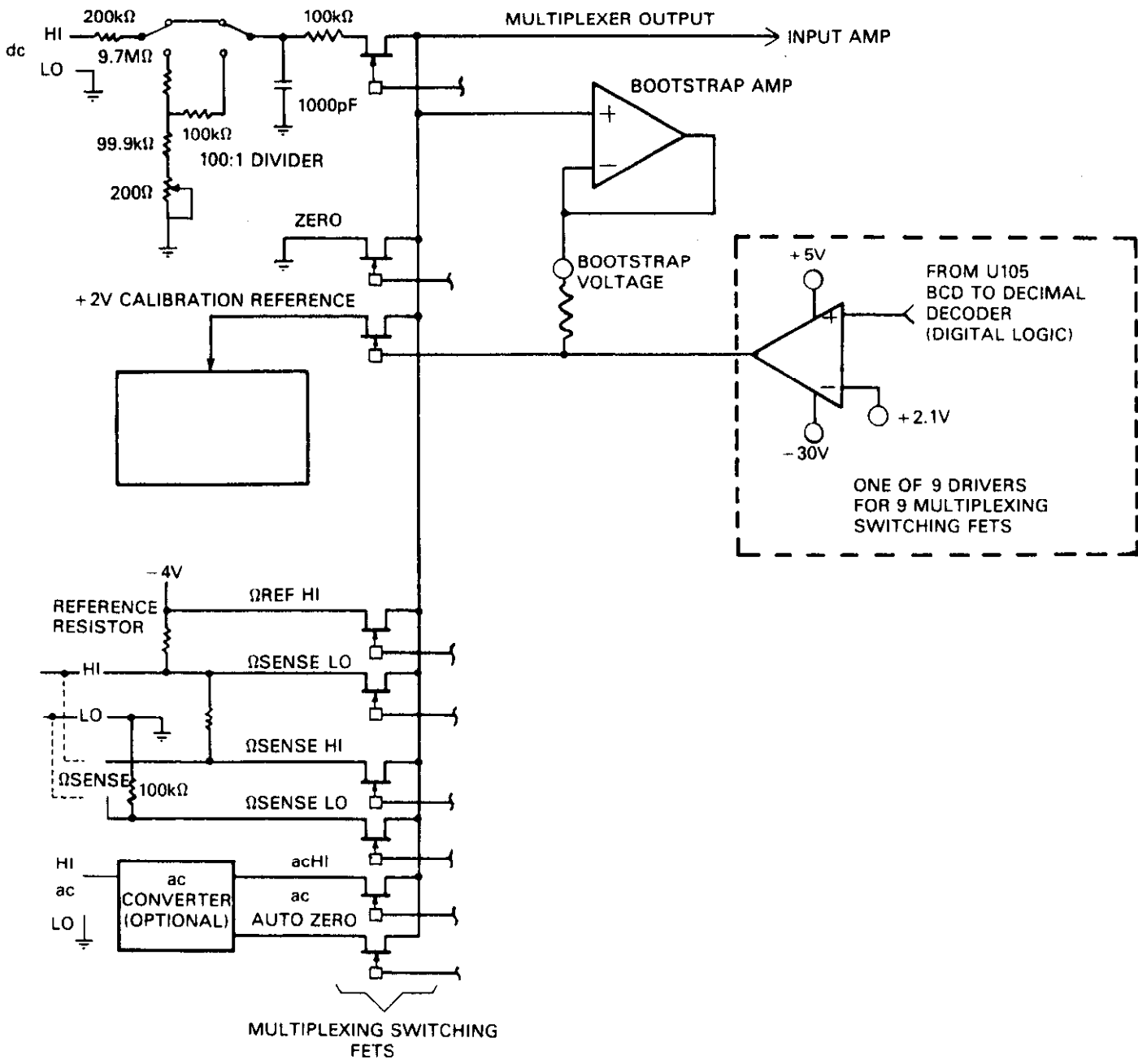

Figure 7-2. Simplified Multiplexer Schematic (Refer to Figure 7-1, Block A)

converter also requires various control signals and data processing capabilities to perform the A/D conversion process and to compute the results. Inputs applied to the Model 192 are switched by the multiplexer. These input signals along with zero and full scale references are systematically switched by the Model 192. Only one signal at a time is allowed to pass through the multiplexer which is then routed to the Input Amplifier, this amplifier acts as a buffer and is capable of multiplying the output of the multiplier by a gain of one or ten.

The digital output of the A/D converter inputs to the microcomputer. Here the results of the A/D conversion are computed, and this information is sent to the display circuits of the Model 192. If the Model 1923 remote programming option is installed, the results of the A/D conversion are sent to this option and will be placed on the IEEE general purpose interface bus.

7.3 ANALOG CIRCUIT DESCRIPTION

7.3.1 Input Multiplexer

The Input Multiplexer connects one of nine signals to the Input Amplifier. (Refer to Schematic 30976D). A volts or Ohms measurement requires several inputs to be connected to the input amplifier. Each input is connected in sequential order. The microcomputer of the Model 192 controls the switching sequence and determines the length of time that each multiplexer switch is turned on.

Switching of the various inputs and reference signals is accomplished with nine J-FET transistors (Q310, Q311, Q312, Q327, Q328, Q334, Q339, and Q341). A problem is encountered when using J-FET transistors as switches. When the J-FET is turned on, the low to high transition of the switching voltage causes charge coupling into the analog signal the FET is switching. The effects of these transients were eliminated by the use of software generated delays. However, it is necessary to drive the gate of each FET switching transistor with the input signal voltage to turn it on. That is accomplished with a bootstrap amplifier which operates as a voltage follower. Its input is connected to all the FET switches; therefore, its output follows the voltage that is selected by whichever FET switch is selected by the microcomputer.

Gate drives for these FETs are controlled by differential comparators (U321, U304, and U305). The comparators convert logic level signals to voltage levels suitable for turning off and on the J-FET transistor. To turn a J-FET transistor off, the comparator output transistor pulls the J-FET gate to -29V (see the equivalent circuit of Figure 7-2). To turn on the same transistor, the comparator's open collector output transistor turns off. This allows the gate to be pulled to the bootstrap voltage. The bootstrap voltage is virtually the same as the drain voltage of the switching FET. For further information about the bootstrapping process, see paragraph 7.3.5. The following paragraphs discuss the operation of the Input Multiplexer during DC volts, AC volts, and ohms measurements.

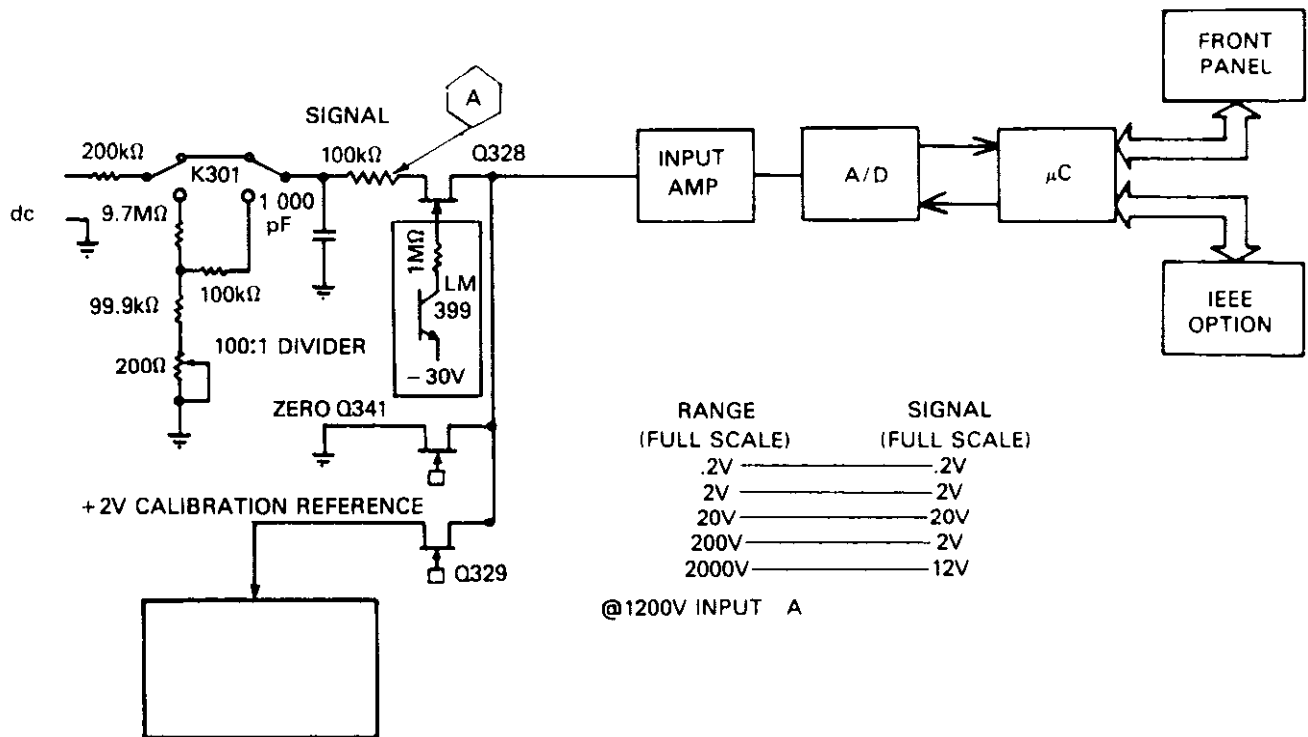

Figure 7-3. DC Voltage Measurement

7.3.2 DC Voltage Measurement

In DC volts operation, as shown in Figure 7-3, the input signal either goes directly to the Input Amplifier or is connected across a 100:1 attenuator with a total resistance of 10MΩ. The attenuation of the DC input signal is determined by the range selected. Three input signals to the A/D converter are required for DC volts operation (i.e. V_{SIG} , V_{ZERO} and V_{REF}). Each signal is required to the A/D input and measured for 16.6 msec (See A/D Converter, paragraph 7.3.6). Each digitized value is stored in memory and then used to calculate a reading by the formula:

$$V_{DISP} = 2 \frac{(V_{SIG} - V_{ZERO})}{(V_{REF} - V_{ZERO})}$$

It can be seen that the zero error is subtracted from both the signal and the reference, and then the ratio is taken. Multiplication by two is needed because the reference is 2V. In taking a DC reading on the bench, the voltage seen at the high DC voltage input terminal is switched by the associated FET to the isolating input amplifier. The amplifier then passes the voltage to the converter, which digitizes it and passes it on to the processor which stores it. Next, the zero input FET is turned on and a zero input is processed and stored in the same way. Then the output of the 2V reference

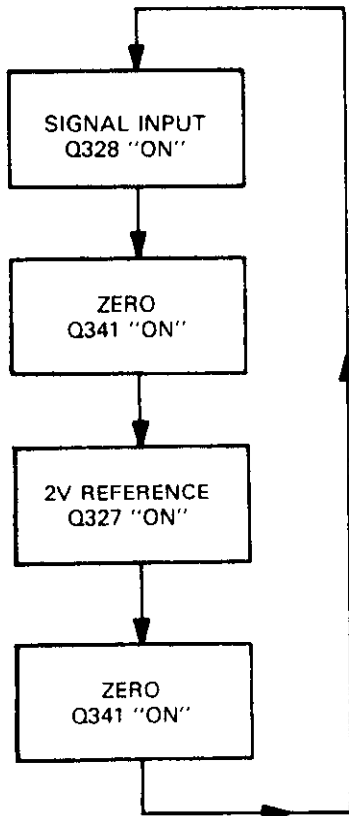

Figure 7-4. FET Switching Sequence for DC Voltage Measurement (Bench Mode of Operation)

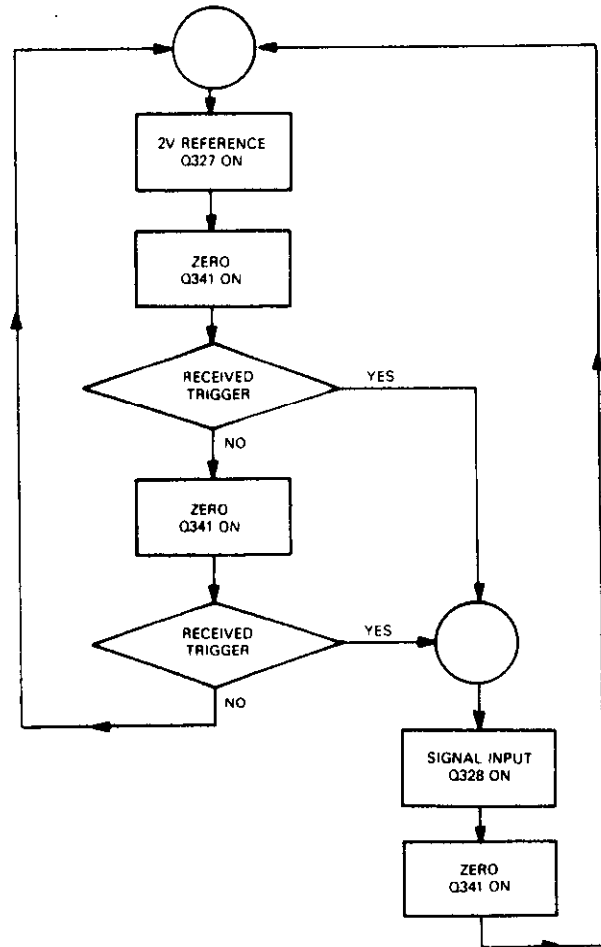

Figure 7-5. DC Voltage Measurement FET Switching Sequence (System Mode of Operation)

circuit is processed and stored, and finally, another zero input is similarly processed. The last zero is necessary because the gain in the input amplifier is switched resulting in a different offset voltage. When all four inputs have been obtained, the processor calculates a reading, and displays it. Each switching FET is allowed to stay on for a period of time and then turned off before proceeding to the next step in the flow chart (Figure 7-4). The "ON" time for each FET is controlled by the Model 192's microcomputer.

Range switching of the input signal from the 200mV, 2V or 20V range to the 200V and 1kV range is accomplished via relay K301. The relay is controlled by a 3 to 8 decoder (U322). Decoding is a function of the Shift Registers of the A/D control logic. The relay decoder is also used to select ranges for the AC Voltage option.

In system operation, a DC voltage reading is obtained in a slightly different manner to get faster results. In the One-Shot mode, the meter continuously multiplexes, digitizes, and stores zero and calibration inputs until a measurement triggers occurs and the input from the high terminal is

digitized. The processor can then produce a reading much faster than it would using the bench method.

During system operation a WAIT command can be used. A "W1" command programs the Model 192 to turn on Q328 for 14ms (Default condition). A "W0" command turn on Q328 for 4ms. The modes are only recommended for AC voltage source resistances of less than 100kΩ.

7.3.3 Resistance Measurement

For resistance measurements, four inputs are required so the Model 192 can obtain a reading by means of a ratiometric technique. The required inputs are:

- Ohms Reference HI
- Ohms Reference LO
- Ohms Sense HI
- Ohms Sense LO

The ratiometric technique is a mathematical process that compares numbers and then derives a ratio from them. In the Model 192 the ratio is a voltage ratio that is created by a common current flowing through two resistors in series. The current passes through both a known reference resistor and the unknown resistance. The current through both resistors can then be determined by measuring the voltage drop across the known resistor and then calculating the current. Once the current through the unknown value resistor is calculated and the voltage drop across it is measured, the unknown resistor's value can then be calculated.

Five FET switches (Q301, Q302, Q303, Q306, and Q308) select one of five known value resistors (see Figure 7-6). Each of the resistors is associated with a specific ohms range. The resistor selected by the FET switches is equal to one half of the full scale range. For example, a 10k known value resistor is used on the 20k range, and a 100k resistor is used on the 200k range.

The voltage across the selected range resistor appears at Q310 (REF HI) and Q333 (REF LO). The voltage across the unknown resistor appears at Q334 (SENSE HI) and Q339 (SENSE LO). An ohms source voltage of -400mV is used on the .2k ohm range, and -4V is used for all other ohms ranges. As mentioned earlier, four input signals are required for ohms measurements. Each signal is measured for 16.6msec. The signals are converted to a digital number and stored in the microcomputer of the Model 192. The microcomputer then calculates the measured value using the formula:

$$DISP = \frac{(\Omega_{SENSE HI}) - (\Omega_{SENSE LO})}{(\Omega_{REF HI}) - (\Omega_{REF LO})}$$

It can be seen that $(\Omega_{REF HI}) - (\Omega_{REF LO})$ is the voltage across the known resistance and that $(\Omega_{SENSE HI}) - (\Omega_{SENSE LO})$ is the voltage across the unknown resistor.

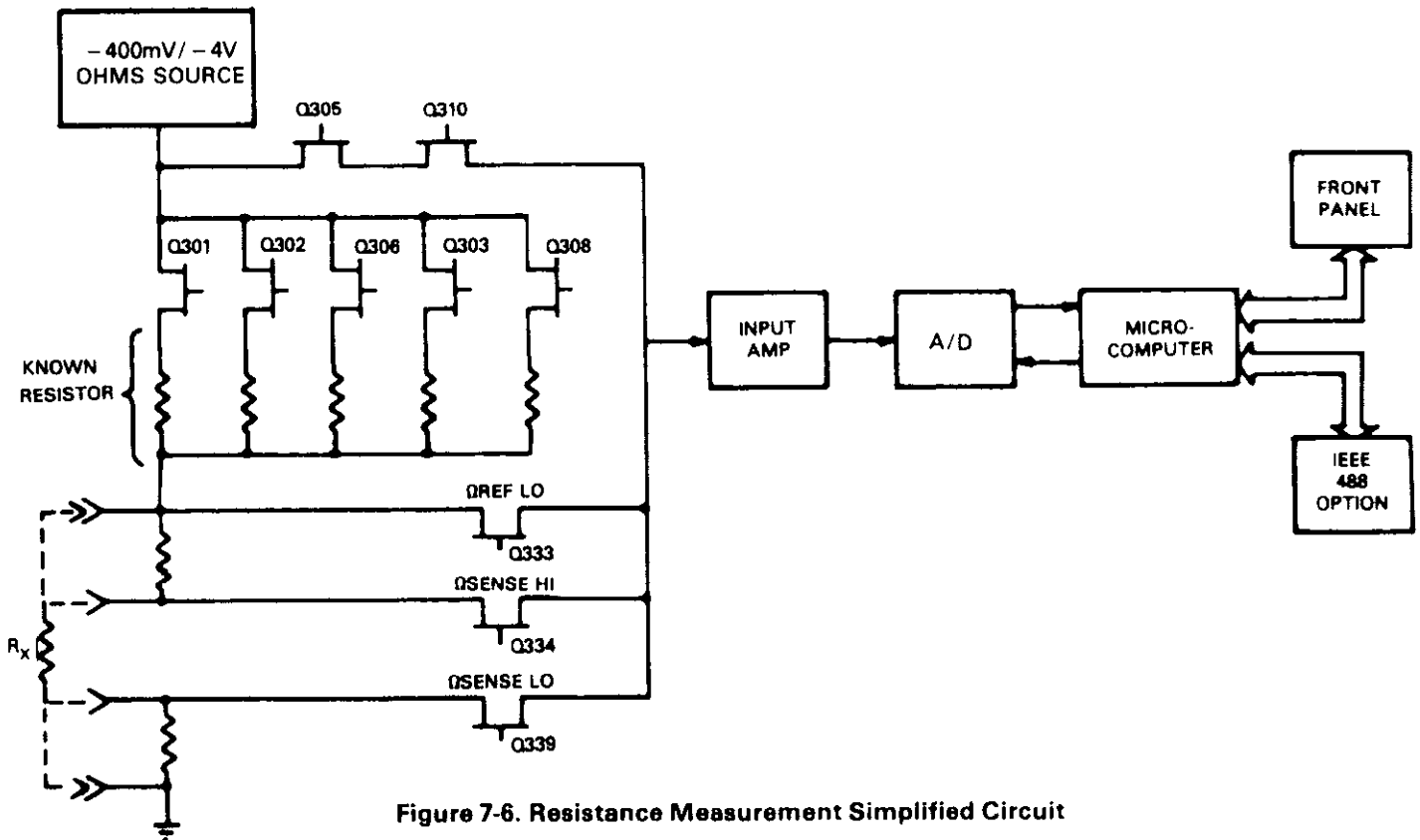

Figure 7-6. Resistance Measurement Simplified Circuit

Switching for Ohms operation is shown in the flow chart (Figure 7-7). In taking an ohms reading, the voltage seen at the $\Omega_{SENSE HI}$ terminal is switched by Q334 to the input amplifier, digitized, and stored in memory. Next, the ohms SENSE LO FET (Q339) is turned on in the same manner. Then the voltage at the ohms REF LO terminal is processed and stored, and finally the ohms REF HI input is similarly processed. When all four voltage inputs have been obtained, the processor retrieves the stored values, performs a calculation for the precise reading, and displays the value.

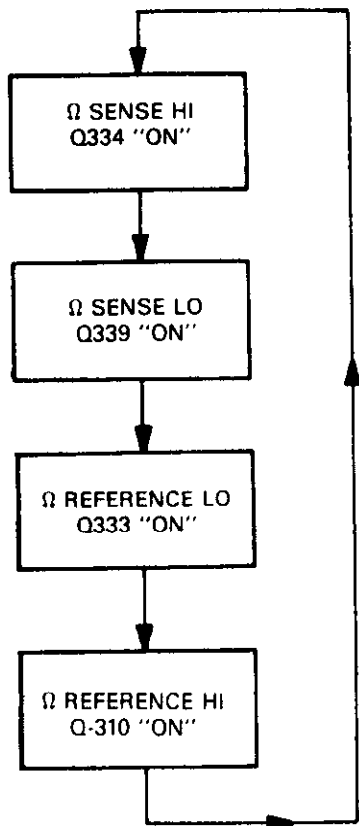

Figure 7-7. FET Switching Sequence for Ohms Measurement

Up to this point, the effect of lead resistance on the resistance measurement has not been considered. As shown in Figure 7-8, lead resistance can affect the display ohms reading in both 2-terminal or 4-terminal measurements. For this explanation, resistance of the test leads have been designated as R1–R4. If SENSE HI and LO terminals are not connected to R_X , the sensing occurs at the HI and LO input terminals through resistors R_S and the displayed reading includes the resistance of R1 and R4 added to the unknown (R_X).

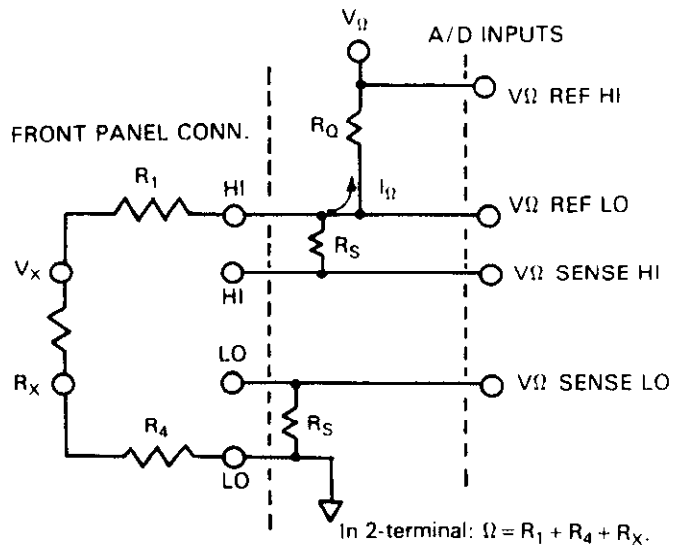
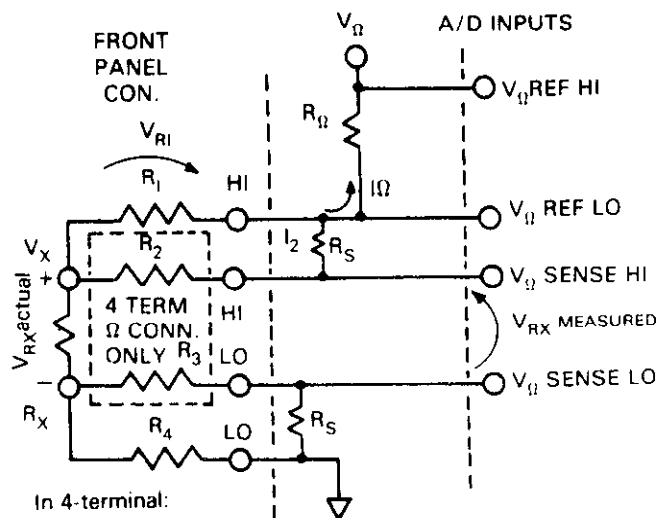

Figure 7-8. Affect of Lead Resistance in 2-Terminal Ohms Measurements

For 4-terminal measurements, the Ω SENSE leads are connected to R_X and the effect of lead resistance can be calculated as shown in Figure 7-9. It can be readily seen why the stated accuracy for the 200k Ω range requires that the effect of lead resistance be cancelled with the ZERO push button for both 2-terminal and 4-terminal measurements.



In 4-terminal:

$$V_{RX \text{ MEASURED}} = V_{RX \text{ ACTUAL}} + 2 \times \frac{V_{R1} \times R_2}{R_2 + R_S}$$

$$[I_{SENSE} \times R_2]$$

with $R_2 \approx 10 \Omega$ and $R_S \approx 100k\Omega$

$$V_{RX \text{ MEASURED}} = V_{RX \text{ ACTUAL}} 2 \times \frac{V_{R1}}{10^4} \approx V_{RX}$$

Figure 7-9. Affect of Lead Resistance in 4-Terminal Ohms Measurements

7.3.4 AC Voltage Measurement

In AC Volts operation, the Model 1910 AC Voltage Option is installed between the AC input terminal and the Input Amplifier (see Figure 7-10). The Model 1910 converts the AC input voltage to a DC voltage between zero and -2V. On other than the 2V range, the input signal is divided by 10, 100, or 1000 depending on the range selected. For AC voltage measurements, four input signals to the A/D converter are required. Each signal is measured for 16.6msec and its digitized value is stored in memory. The microcomputer then calculates a reading using the formula:

$$V_{AC} = \frac{2(V_{AC HI} - V_{AC AUTO ZERO})}{(V_{REF} - V_{ZERO})}$$

Where $V_{AC HI}$ is the Model 1910 output, $V_{AC AUTO ZERO}$ is its DC offset, V_{REF} is the 2V reference, and V_{ZERO} is signal ground. The 2 is required because of the 2V reference. Since AC volts is a four phase measurement, the maximum conversion rate for AC volts is two readings/second.

Switching for AC volts operation is shown in the following flow chart (Figure 7-11). In taking an AC reading, the voltage seen at AC HI is switched by Q311 to the input amplifier. The voltage is then processed and stored in the same manner as described for DC Volts and Ohms operation. Next, the AC auto zero FET (Q312) is turned on and the voltage seen there is processed and stored. The processor then retrieves the stored voltages, calculates a reading, and displays it.

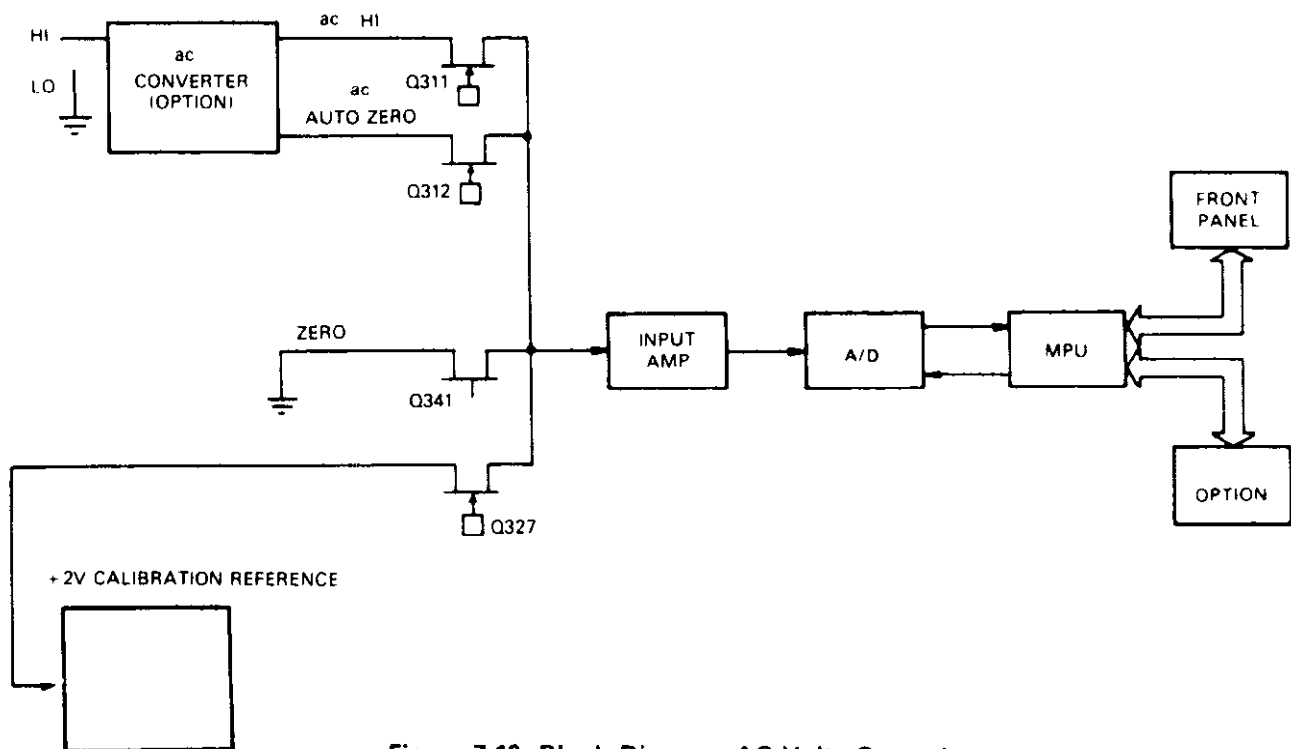

Figure 7-10. Block Diagram AC Volts Operation

7.3.5 Input Buffer Amplifier

The Input Buffer (Figure 7-12) is a non-inverting low noise, high input impedance amplifier which looks at each input with either X1 or X10 gain. Its output is capable of voltage swings of $\pm 20VDC$. These parameters are beyond the capabilities of a single op amp. Two op amps, one having high input impedance/low noise characteristics (U301) and the other having a wide output voltage swing (U303), were combined to produce the desired characteristics. A third operational amplifier, U302, operates at unity gain. Its supplies are bootstrapped to the input to $\pm 6V$ via zener diodes VR301 and VR302 and emitter followers Q314 and Q315. This bootstrapping technique centers the $\pm VB$ supplies around the input potential of U301. U301 can then handle input signals up to $\pm 20V$ while providing linear operating characteristics.

If the input amplifier had to provide only unity gain, this arrangement would be adequate; however, on the 0.2V and 2V ranges a gain of ten's required. Operational amplifier U303 supplies the outer capability for the $\pm 20V$ output swing.

7.3.6 A/D Converter

A simplified schematic of the A/D converter is given in Figure 7-13 and its waveform is shown in Figure 7-14. In operation, the output of the input buffer is applied to the Transconductance Amplifier. This amplifier provides two functions. It converts the input voltage to a current, which

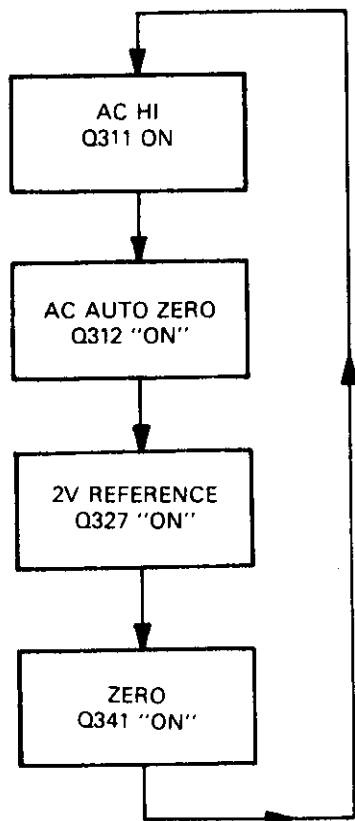

Figure 7-11. AC Volts Operation Flow Chart

goes to the integrator when requested, and also provides an offset current so that its bipolar input voltages are converted to unipolar output currents.

The A/D converter operates first in a charge balance (CB) phase, and then in a single slope (SS) phase. A 16.6msec interval at 60Hz and 20msec interval at 50Hz were selected to sample each input as the best compromise to achieve good line rejection and relatively fast conversion speed.

A CB phase is begun when INPUT DISABLE goes low. This occurs at the completion of a delay period that allows the signal to settle after turning on the appropriate input MUX switch. The delay is software generated and is dependent on the function selected, as given in Table 7-1. When INPUT DISABLE is removed, I_{IN} is connected to the integrator, and V_o ramps positive. The D flip-flop then acts as a comparator, providing timing and control. After V_o exceeds the D threshold of U314, Q_1 goes high at the next positive going clock edge. At the next clock edge (negative going), Q_2 goes high and connects I_{CB} to the integrator. I_{CB} is greater than $2I_{IN}$ maximum, and thus, V_o immediately ramps negative.

\bar{Q}_2 is also low at this time which resets and holds Q_1 low. At the next negative clock edge (1 cycle later), I_{CB} is turned off

and D_1 is enabled by Q_2 going low again. (\bar{Q}_2 goes high and removes the clear from U314A.) Up to this point, I_{CB} was turned on for one clock cycle (2 μ sec) and then turned off. The earliest it can be turned on again is one clock cycle later. Each time I_{CB} is turned on, a counter is incremented by an inverted V-F PULSE from Q_2 . The flip-flops divide the clock frequency by two, limiting the maximum number of charge balance integrations and output counts to one half of the clock frequency (240kHz). In the precise 16.6msec charge balance period, the maximum number of times that \bar{Q}_2 can go high and be counted is $16.6\text{msec} \times 240\text{kHz} = 4000$ counts.

Table 7-1. Settling Delays, S^N on to Turn On of Integrator

JFET Switch	Delays (msecs)		
	DCV	ACV	Ω
S1	30	30	100
S2	1	1	1
S3	1	1	100
S4	X	1	1

At the end of the charge balance phase, the output of the integrator is resting at some positive voltage. The single slope comparator output is also positive and will not switch until the integrator output crosses zero. The comparator output is ANDed with a one millisecond pulse in the digital section to produce SINGLE SLOPE ENABLE. This allows I_{SS} to flow into the integrator. A 3.84MHz clock is counted from the time SINGLE SLOPE ENABLE went high until the single slope comparator changes state (V_o crosses zero). When this occurs, I_{SS} is shut off and the counting is stopped. The amount of charge quantized by I_{SS} is equal to $1/1024$ of the charge quantized by I_{CB} . The microcomputer multiplies the CB counts by 1024 and adds the SS counts to it to obtain the composite count (4.1 million maximum).

7.4 DIGITAL AND DISPLAY CIRCUIT DESCRIPTIONS

7.4.1 Microcomputer (Refer to Schematic 30975D)

The microcomputer and its associated logic circuitry provide timing and control of the Analog-to-Digital conversion process. Additional functions provided by the microcomputer include operation of the Front Panel Display, implementation of Front Panel Programs, and the control of data through the Model 1923 IEEE-488 option.

The microcomputer includes a 6808 microprocessing unit (MPU), a 6522 versatile interface adapter (VIA), two 2732 read only memories (ROMs), two 2114 access memories (RAMs), an address decoder, a data bus driver (front panel interface), and the necessary reset logic. (See Figure 7-15.) The total memory utilized in this system consists of: 8K \times 8 bytes of ROM (two 4K \times 8 PROMs/U129 and U130) for program control, 1K \times 8 bytes of RAM (two 1K \times 4 RAM's/U123 and U124) for temporary storage; 8K \times 8 bytes

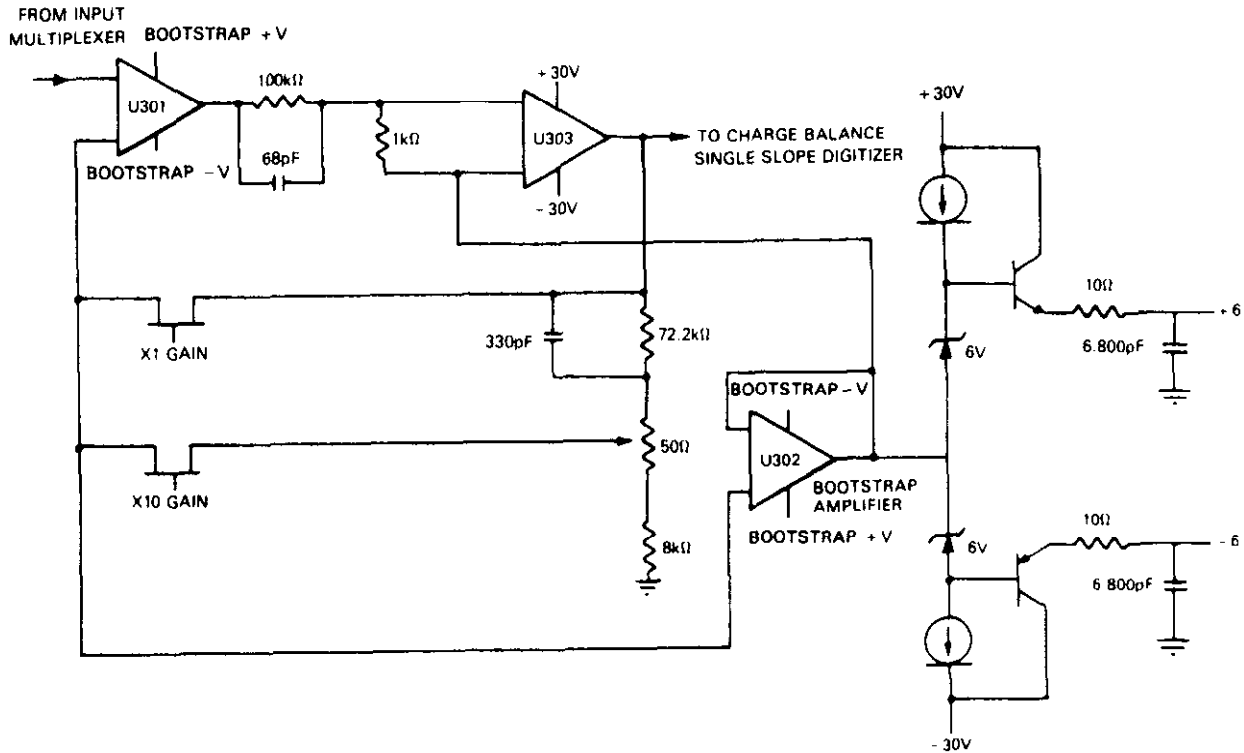

Figure 7-12. Simplified Input Buffer Schematic (Refer to Figure 7-1, Block B)

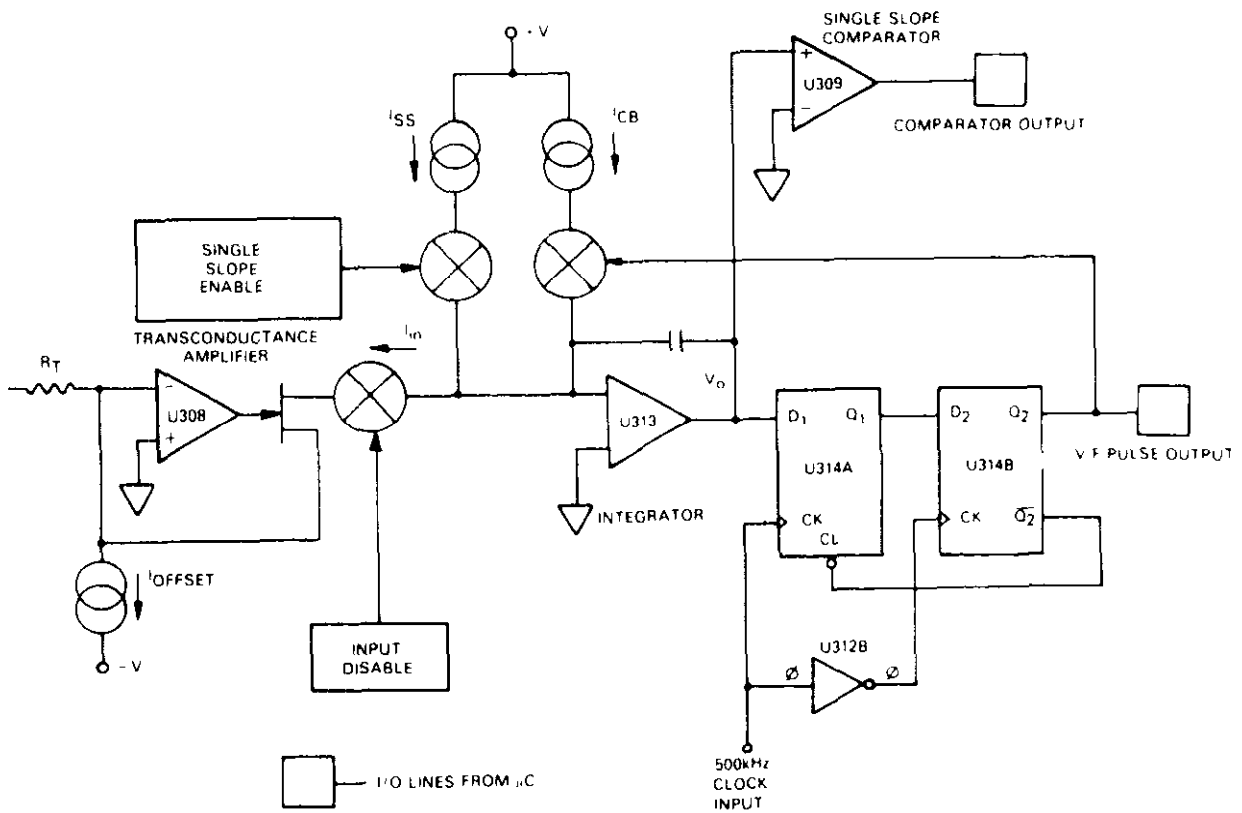

Figure 7-13. Simplified A/D Converter Schematic (Refer to Figure 7-1, Block C)

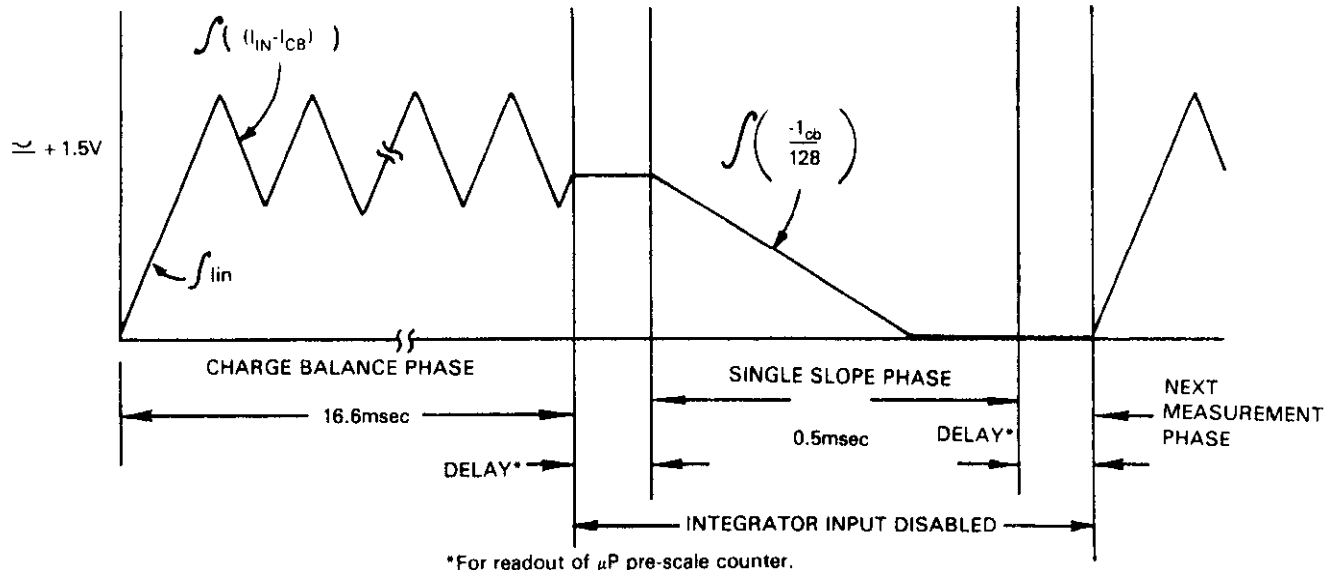

Figure 7-14. A/D Converter Integrator Output Waveform

for the IEEE-488 option, and 16 bytes for the VIA (U132) to control peripherals. Provisions have been made for future memory expansion by including an additional socket on the mother board to accommodate an additional 4K × 8 bytes of ROM (PROM/U134).

7.4.2 Memory

Note that the total memory used (8K of ROM, 1K of RAM, 8K of IEEE-488, and 16K of VIA) is a small portion of the entire addressing capabilities of the 6808 MPU (U131). The microprocessor is capable of handling 64K × 8 bytes (precisely, 65,536/8 bit words). Memory locations for the 64K addresses are assigned the values 0000_{16} through $FFFF_{16}$. The ROMs, RAMs, VIA, and Data Bus Drivers (U128) are each allotted 8K bytes of memory. An 8K byte is reserved for the IEEE-488 option. For example: although

only 1K of RAM is utilized, an 8K portion or "chunk" of memory is reserved or dedicated for the RAM function. In a similar manner, 8K bytes are reserved for each PROM even though each PROM can store only 4K, 8 bit words. An additional 8K bytes are dedicated to the VIA while only 16 bytes are used. Another 8K memory is reserved for front panel control (Data Bus Driver, U128) however, these memory locations are never addressed. This will be explained in the following paragraphs. Finally, an 8K × 8 byte in memory is reserved for the IEEE-488 option (the option only requires 4K of memory). Refer to Table 7-2 for specific address locations reserved for the various functions. Note that an 8K byte of memory is not assigned ($6000-7FFF$).

Table 7-2. Memory Byte Locations

Device Selected	MPU Memory Byte Locations	No. of Bytes	Address			Output
			A15	A14	A13	
RAM (U123, U124)	0000-1FFF	8K*	0	0	0	Y_0
VIA (U132)	2000-3FFF	8K*	0	0	1	Y_1
Buffer (U128)	4000-5FFF	8K****	0	1	0	Y_2
	6000-7FFF	8K**	0	1	1	Y_0
IEEE-488	8000-9FFF	8K*	1	0	0	Y_4
PROM (U129)	A000-BFFF	8K*	1	0	1	Y_5
Socket (U134)	C000-DFFF	8K***	1	1	0	Y_1
PROM (U130)	E000-FFFF	8K*	1	1	1	Y_3

- * Dedicated/not necessarily all utilized.
- ** Not assigned.
- *** For future PROM expansion.
- **** Never accessed.

7.4.3 Address Decoder

Interfacing of the microprocessor with the RAMS, ROMS, Front Panel, VIA or the IEEE-488 option is controlled by the Address Decoder (U121). Partial address decoding is used in this system. The 3 to 8 Address Decoder selects one of the seven devices (V_0 is not used) listed in the Table 7-2 via upper three most significant lines; A13, A14, and A15. (The A12 address line of the MPU is not used.) The seven addresses determine which of the two PROMs are selected; the upper 8K ($E000_{16}$ through $FFFF_{16}$ /U130) or another 8K byte in memory ($A000_{16}$ through $BFFF_{16}$ /U129). Remember, the ROMs memory capacities are only half (4K) of the addresses allocated for them. Also selected are the two $1K \times 4$ RAMs (connected together to provide $1K \times 8$), the front panel input, the VIA, the IEEE-488 option bus, and third PROM, are provided for expansion.

As mentioned in the preceding paragraph, the function selected is determined by the state of the addresses A13, A14, and A15. These address lines determine which output is selected at the decoder (U121) in accordance with Table 7-2. Only one of the devices will have access to the DATA BUS at any time. The address decoder selects one of the devices only after a valid memory address has been asserted at the decoders input (E3). The valid memory address (VMA signal) is generated by the MPU approximately 200nsec after $\phi 2$ time. ($\phi 2$ is the MPU's 1MHz output clock.) This is sufficient time to allow for the address lines to settle. The accuracy of this main timing signal ($\phi 2$) is controlled by a 4MHz external crystal, Y101; the microprocessor then divides this signal by four.

7.4.4 Reset

U125, U126 and U122 form a "reset" network which together resets the MPU, VIA, and the IEEE-488 option in the event the front panel display is not updated after a specific period of time has elapsed due to a lost program or power line transient.

The 1MHz timing signal from the MPU ($\phi 2$), clocks a 2^{14} (16,384) stage counter (U125) whose output conditions a second counter (U126) to enter a count down mode after a period of 16.6msec. ($1\text{MHz} - 16,384 = 60\text{Hz} = 16.6\text{msec}$). After the 16.6msec A/D integration period has elapsed and display update data is not present at the output of the VIA (PB5) because of a possible system malfunction, U126 will continue to count down until Q3 goes low and resets the system. As long as update data is present at PB5, the VIA clocks this data into the Display. This same clock pulse (CA2) inhibits the reset condition. The lead edge of CA2 is detected at the lead-edge-detector (one-shot/U122A, U122b, and C126) and presets or "loads" a 15 count into U126. It can be seen then, that as long as data is present, a reset will never be generated because the data pulse will continually reload the counter back to 1111 (15) before it has a chance to count down to 0111 (7). Note that 8 count down

pulses would have to occur for a "reset" which is equivalent to eight 133msec A/D integration periods with no data present. If update display data is not present within this 16.6msec period, Q3 of U126 will go low and reset the MPU, VIA and IEEE-488 option (if present). The system will remain reset until $\overline{\text{RESET}}$ returns high.

7.4.5 Front Panel Switch Port

Information from the Front Panel function and mode selection switches is placed on the Data Bus (lines D0 through D4 and D7) through the Data Bus Driver (U128). The four inputs to this tri-state buffer (switch port) are routed from the front panel switches. Note that there are only four switch inputs (SW1-SW4). The switches are connected in a matrix configuration such that each switch input serves more than one function or range. Although the address decoder has reserved an 8k byte in memory for this device the memory locations are not accessed or addressed by the Bus driver. A fifth input to the Data Bus Driver is from the line frequency 50/60Hz detector (Q102).

7.4.6 Line Frequency Detector

Q102 and associated components form the 50/60Hz detector. The base of Q102 monitors the power line/frequency via R120 which is connected to the secondary of a power supply transformer. The 50 or 60 Hertz signal is squared off and placed on the data bus. The MPU then determines whether the line frequency is 50 or 60 Hertz to establish the basic integration period (16.6msec at 60Hz/20ms at 50Hz). The unit will perform as though the line frequency is operating at 50Hz if the line source is actually 400Hz. This is necessary since 400Hz is an even multiple of 50Hz; therefore, 8 line pulses are required to establish the basic integration period at a line frequency of 400Hz (the A/D cannot operate at this speed).

7.4.7 Isolation

There is 1500 Volts isolation between the microcomputer and the A/D control logic. Isolation is achieved with the use of opto isolators AT101 through AT104. A/D output data is isolated from microcomputer by opto isolator AT104. AT101, AT102, and AT103 provide isolation between the microcomputer outputs PB7, CB1, CB2, and the A/D control logic.

7.5 A/D CONTROL

The conversion from analog data to digital data begins with the integration cycle. An integration cycle begins with the appropriate signals to the analog circuits enabled by one or more of the S1 through S27 lines going high. These are the output lines of shift registers, U103/H3 and U104/E5, and the binary-to-decimal decoder, U105/H4. The three devices serve as output latches. Latch functions are listed in Table 7-3.

Table 7-3. Functions of Latch Outputs

Command	Function
S1	Pin A input of 4 to 10 Decoder
S2	Pin B input of 4 to 10 Decoder
S3	
S4	Pin C input of 4 to 10 Decoder
S5	
S6	200k Ohms range select
S7	
S8	2k Ohms range select
S9	
S10	
S11	
S12	2V REFERENCE multiplex control
S13	
S14	Input buffer 1000V range control
S15	DC HI multiplex control
S16	AC HI multiplex control
S17	AC AUTO ZERO multiplex control
S18	ZERO multiplex control
S19	OHMs SENSE LO multiplex control
S20	OHMs SENSE HI multiplex control
S21	OHMs REFERENCE HI multiplex control
S22	OHMs REFERENCE LO multiplex control
S23	Input buffer X1 control
S24	Transconductance amplifier range control
S25	Input buffer X10 control
S26	0.2k OHMs range select/OHMs source range select
S27	Transconductance amplifier range control

The microprocessor waits for the inputs to settle before clocking the shift registers. The charge balance phase is initiated when the first stage (Q1) of the shift register (U110) goes high (CB START signal). (See Figure 7-16.) When CB START is "true" the "D" input of the charge balance flip-flop, U108, and the input of gate U107B are at the logic "1" state. This logic high is gated through and clears the 4 bit divide-by-16 counter (U101B). The next rising edge of the 2.4kHz clock signal sets the flip-flop whose Q output goes low and enables the integrator by forcing INPUT DISABLE low. The microprocessor waits 16.66msec (the integration period for 60Hz; 20msec or 50Hz) and the charge balance line returns to 0. At the next rising edge of the 2.4kHz clock, the Q output of the flip-flop goes high again and disables the input to the integrator, ending the exact 16.66msec integration period. Notice that the clock frequencies are crystal controlled; however, the entire process is actually under microprocessor control at all times.

While the integration period is taking place, pulses (V-F PULSES) are inputted into the 4 bit counter (U101B). When the counter overflows after 16 counts occur, clock pulses are generated at its 2Q₀ output which the VIA counts in an internal counter (PB6). These clock pulses become the most significant bits of the result. At the end of a charge balance phase, 4 bits of data are left on the counter. This data is obtained by setting the remainder line to "1" (Q3 of the shift register, U110) and allowing STROBE pulses from the VIA

(PB7) to pass through gates U102B, U107C to ultimately clock the 4 bit counter. By strobing the counter in this way and waiting for the counter to overflow, the remainder may be determined. The number left in the counter is equal to 16 minus the number of strobe pulses. This data now becomes the next significant 4 bits of the 24 bit result.

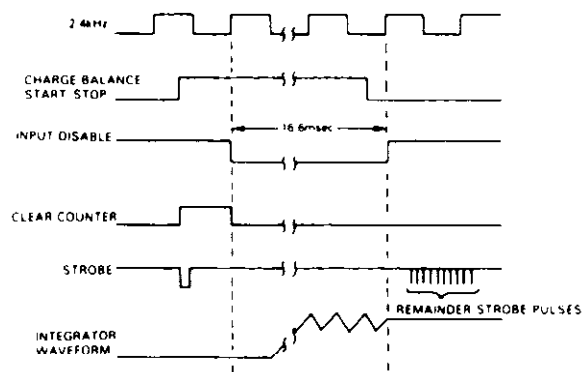

Figure 7-16. Charge Balance Timing

The single slope phase begins when the SS START line (Q2 output of the shift register, U110) goes high. (Refer to Figure 7-17.) The SS START signal controls the D input of the single slope flip-flop, U108B (G2). On the next rising edge of the 3.84MHz clock, the single slope flip-flop is set

and its Q output is ANDed with the COMPARATOR OUTPUT at U107D to generate the SINGLE SLOPE ENABLE signal. In addition, gate U102A is enabled and the 3.84MHz clock pulses are counted at U101B in the same manner the V-F pulses were counted in the charge balance phase. The single slope phase ends when the comparator goes to a "0" and gates off the 3.84MHz clock to the counter. The remainder left on the counter is again read as in the charge balance phase. The result is added to the charge balance phase and single slope phase. The result is broken down as follows:

24 BIT RESULT

- 8 Bits—These 8 most significant bits are accumulated in the VIA each time the 4 bit counter overflows during the charge balance phase.
- 4 Bits—This is the remainder left on the 4 bit counter during the CB phase.
- 8 Bits—The 8 most significant bits are accumulated in the VIA each time the 4 bit counter overflows during a single slope phase.
- 4 Bits—This is a remainder left in the 4 bit counter during the single slope phase.

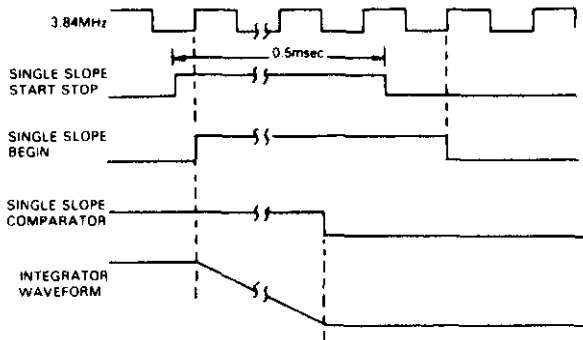

Figure 7-17. Single Slope Phase

One of the many functions of the VIA is to transfer data from the digital side to the analog side of the optical isolators. With the strobe line (PB7) HI, a data transfer starts. One byte of data is stored in the serial register (SR) of the VIA and is automatically clocked through the optical isolators using the clock (CB1) and data (CB2) lines of the serial port. Another 8 bits are clocked out of the VIA. The strobe line (PB7) is brought LO then HI again to shift the 24 bits of data which are shifted into the latches (U103, U110, U104). Four of the bits are used to address the binary to decimal decoder (U105). Refer to Figure 7-18.

7.5.1 Clock Circuit

The 3.84MHz clock is a Pierce oscillator using Q101 as the gain element and a 3.84MHz crystal Y101 as the feedback element. L101 and C108 act as a parallel load. R110, R111, and C110 provide appropriate level-shifting compatible with the TTL input of U107A. The output of U107A provides a

buffered TTL compatible 3.84MHz clock to U101A which runs the charge balance circuitry within the A/D at a 480kHz rate. The 2.4kHz clock is obtained by further dividing the 3.84MHz clock with U101A and U106 (see Figure 7-19). This clock is used to provide an exact 16.66msec (60Hz) or 20msec (50Hz) window and also provides the interruptions for the microprocessor.

7.6 Display Circuit

The display information is outputted on PA0 through PA6 on the VIA (I/O) bus. The information is updated at a 1.2kHz rate which means each digit is ON for 833 microseconds. Each update begins by presenting new segment information on the VIA (I/O) bus (PA0-PA6) and outputting a clock pulse on CA2. The clock pulse inputs to U203 and shifts a digit enable bit to the next digit to be enabled. Every eight times the display is updated, a digit enable bit is generated at PB5 and goes to the enable data input of the shift register. Refer to Figure 7-20.

The first four digit drivers drive the rows of the switch matrix. The switches are arranged in a 4 by 4 matrix, thirteen of which are used. The columns of the switch matrix go to Bits 0-3 of the front panel switch port described in paragraph 7.4.5. The segment drivers are Q201-Q208. In addition to driving the various segments, they also activate the appropriate LED's.

7.7 POWER SUPPLY

The power supply for the Model 192 contains the line voltage fuse (F101), switching components, and a discrete current driver. Because of the simplicity of the design, a block diagram is not required (refer to page 2 of Schematic 30975D).

The components mentioned in the preceding paragraph generate the six voltages required for proper operation of the Model 192. S101 is the front panel main power switch. When this switch is in the "ON" position, AC line voltage is applied to the primary of T101. S102 (internally located) conditions the Model 192 for 110VAC or 220VAC operation by placing the two primaries in parallel or series, respectively.

Closer observation of the schematic will note that within the four bridge rectifiers, there are actually six rectifier circuits. CR103 and CR104 are full-wave bridge rectifiers utilizing their own secondary transformer windings. CR101 and CR102 are dual full wave rectifiers sharing a common center-tapped transformer (e.g. The two diodes at the right in CR101 perform the full-wave rectifier for the +30VDC while the two at the left rectify the AC input for the -30VDC). Notice the similarity in all stages. The components used in the six circuits are listed in Table 7-4 for convenience. All circuits have filters at the outputs of the rectifiers. The raw DC voltages are regulated and then

bypassed. The +15V (U111), the -15V, the +30V, and the -30V are developed solely for the Analog circuits. In addition, the Analog circuits have their own +5V supply (U127).

The +5V supply for the Digital Logic has a series pass transistor/high current gain network (Q103 and Q104) at the

output of its regulator (U133). CR106 compensates for the base to emitter voltage drop across Q103. CR105 provides short circuit limiting. Note that this is the stage where the signal tapped off for the 50/60Hz Detector of the Digital Logic.

Table 7-4. Power Supply Component Identification

COMPONENT	DIGITAL +5	ANALOG				
		+5	+15	-15	+30	-30
Rectifier	CR104	CR103	CR102	CR102	CR101	CR101
Filter	C134	C121	C117	C118	C119	C120
Regulator	U133	U127	U111	U112	U113	U114
Bypass		C122	C113	C114	C115	C116
Current Amp.	Q103/ Q104					

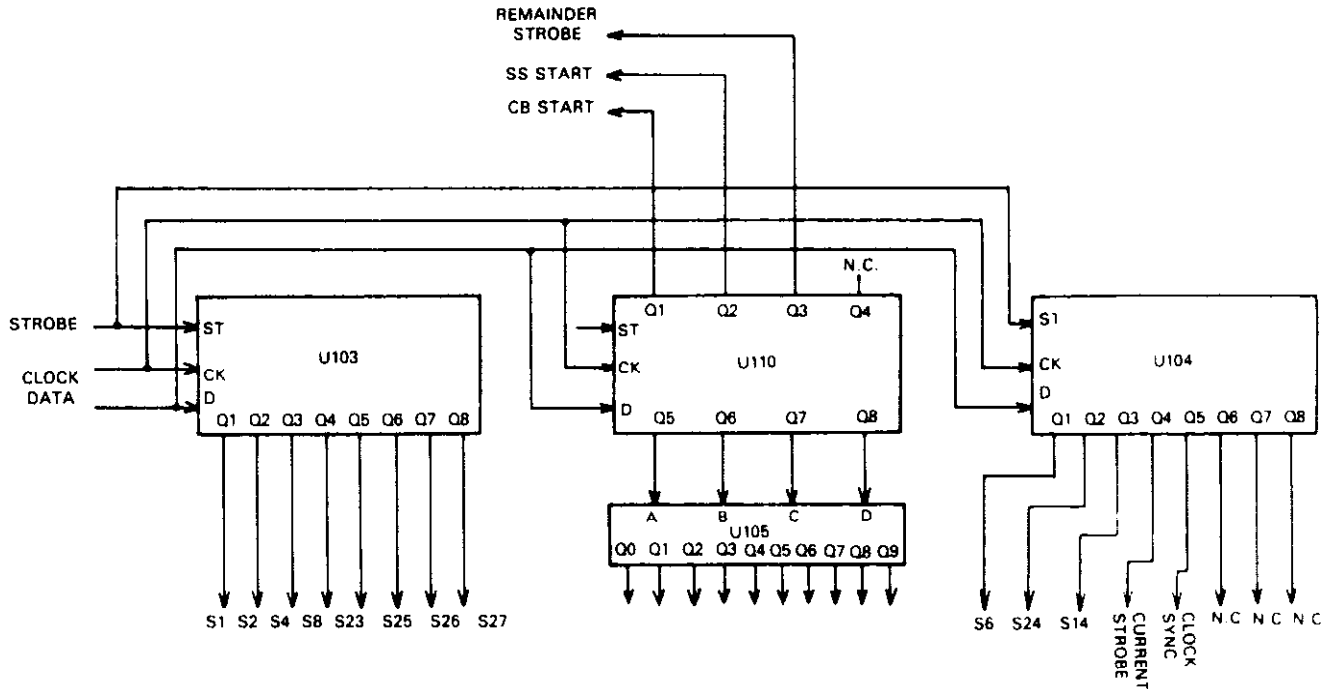

Figure 7-18. Simplified Schematic of Latch (Refer to Figure 7-1, Block E)

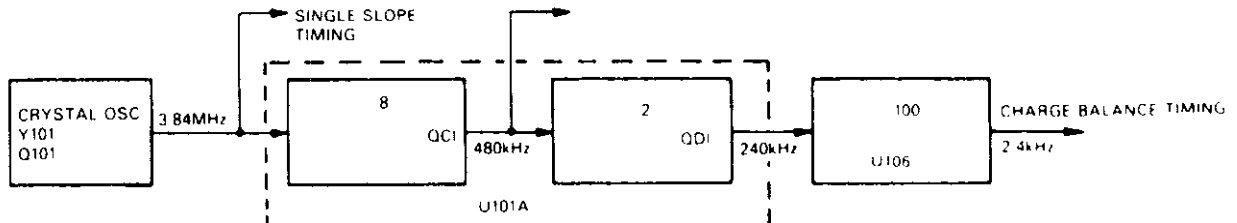

Figure 7-19. Simplified Oscillator/Divider Diagram (Refer to Figure 7-1, Block F)

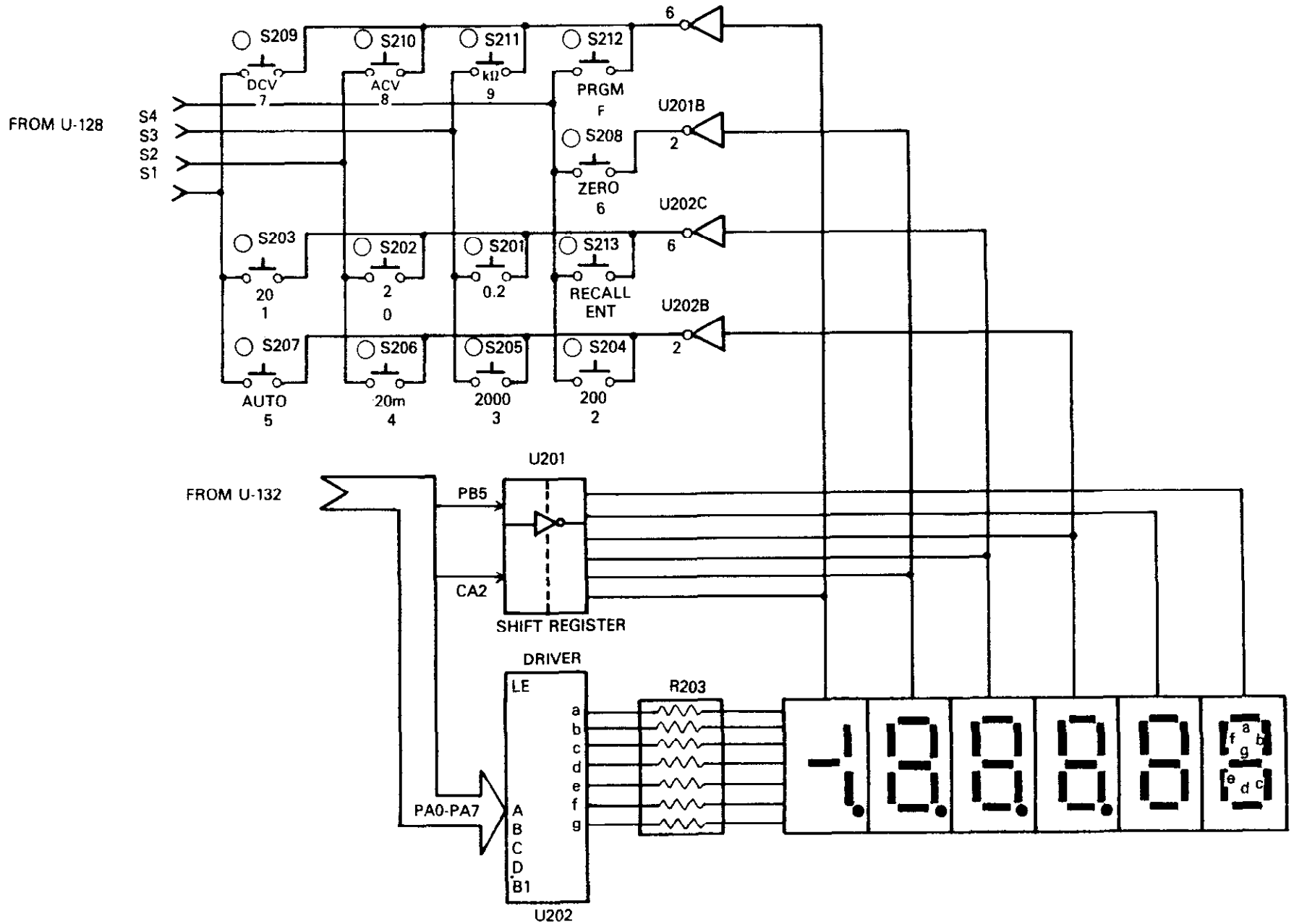

Figure 7-20. Display Schematic (Refer to Figure 7-1, Block G)

SECTION 8 MAINTENANCE

8.1 INTRODUCTION

This section contains information necessary to maintain the Model 192 DMM and the Model 1910 AC voltage option. Adjustment/calibration, troubleshooting, and fuse replacement procedures are provided. Calibration should be performed yearly (every 12 months), or whenever performance verification (see Section 6) indicates that the Model 192 is out of specification. If any step in the calibration procedure cannot be performed properly, refer to troubleshooting information in this section or contact your Keithley representative or the factory. Complete calibration and maintenance information for the Model 1920 and the Model 1923 is provided in the instruction manual supplied with the option.

8.2 CALIBRATION

The following paragraphs explain the calibration procedure for the Model 192.

WARNING

This procedure requires the use of high voltage and is intended for qualified test personnel only. Take care to prevent contact with live circuits which could cause electrical shock resulting in injury or death.

8.2.1 RECOMMENDED TEST EQUIPMENT

Recommended test equipment for calibration is listed in Table 8-1. Alternate test equipment may be used. However, the accuracy of the alternate test equipment must be equal to the specifications in Table 8-1.

8.2.2 ENVIRONMENTAL CONDITIONS

Calibration should be performed under laboratory conditions having an ambient temperature of $23^{\circ}\text{C} + 1^{\circ}\text{C}$, and a relative humidity of less than 70%. If the instrument has been subjected to temperatures outside of this range, or to higher humidity, allow one hour minimum for the instrument to stabilize at the specified environmental conditions before beginning the calibration procedure.

8.2.3 Warm Up

Connect the line cord to an appropriate power source (see paragraph 8.3.2) and depress OFF/ON push button to ON. Allow two hours for warm up before beginning the calibration adjustments.

8.2.4 Calibration Adjustments

WARNING

Some procedures require the use of high voltage. Take care to prevent contact with live circuits which could cause electrical shock resulting in injury or death. Use an insulated tool when making adjustments.

To make calibration adjustments:

1. Apply the appropriate input.
2. Lift off the top cover **MOMENTARILY** to make the adjustment.
3. When the adjustment is made reinstall the top cover.

Table 8-1. Recommended Test Equipment for Calibration

ITEM	DESCRIPTION	SPECIFICATION	MFR.	MODEL
A	DC Calibrator	19V, 190V, 1000V @20ppm	Fluke	343A
B	AC Calibrator	1V, 10V, 100V 220ppm	H-P	745A
C	High Voltage Amplifier (Used with Model 745A)	1000V, 400ppm	H-P	746A
D	Decade Resistor	190 Ω , 1.9k Ω , 190k Ω 1.9M Ω , 10M Ω Certified to 50ppm	ESI	RS725
E	Kelvin-Varley Voltage Divider (Used with Model 343A)	0.19V, 1.9V with 2ppm Terminal Linearity	Fluke	720A

- A. Refer to Table 8-2 and perform the listed adjustments in the sequence indicated. See Figure 8-1 for adjustment locations. Perform steps 1 through 11 to calibrate the basic Model 192. If the Model 1910 AC voltage Option is installed, also perform steps 12 through 19. If the Model 1920 AC voltage option is installed refer to the Model 1920 Instruction Manual for calibration instructions.
- B. To insure that all functions and ranges are operating properly following calibration, utilize the performance verification procedure in Section 6.
- C. If calibration cannot be accomplished or the performance verification procedure indicates a problem, proceed to troubleshooting paragraph 8.3.

assist in isolating the defective circuit or subcircuit. Isolation of the specific defective component has been left to the technician.

NOTE

If the instrument's performance does not meet specifications within 12 months of purchase date, contact your Keithley representative or the factory before attempting any troubleshooting or repair other than fuse replacement.

8.3 TROUBLESHOOTING SET-UP PROCEDURES

The troubleshooting instructions contained in this section are intended for qualified personnel having a basic understanding of analog and digital circuitry used in a precision electronic test instrument. Instructions have been written to

8.3.1 Line Power Fuse (F101) Replacement

If power fails, first verify that the main fuse (F101) is not defective before disassembling the Model 192. (If the Line Voltage Setting is changed (S102) the fuse must be replaced.) The fuse is accessible from the Model 192 rear panel. To replace, proceed as follows:

Table 8-2. Calibration Procedures

Step	Function	Range	Applied Input	Adjustment Point	5½ Digit Desired Reading	Test Equipment
1	Ω	20M	10MΩ	R301	10.0000 ± .5 digits	Decade Resistor
2	Ω	2000k	1900kΩ	R302	1900.00 ± .5 digits	Decade Resistor
3	Ω	200k	190kΩ	R303	190.000 ± .5 digits	Decade Resistor
4	Ω	20k	19kΩ	R304	19.0000 ± .5 digits	Decade Resistor
5	Ω	2k	1.9kΩ	R305	1.90000 ± .5 digits	Decade Resistor
6	Ω	.2k	.19kΩ	R306	.190000 ± .5 digits	Decade Resistor
7	DV	2V	Dial Kelvin-Varley Divider to 0.000000V Depress Zero		.00000 ± 2 digits	DC Calibrator (with Kelvin-Varley Voltage Divider)
8	DCV	2V	1.900000V	R370	1.90000 ± .5 digits	DC Calibrator (with Kelvin-Varley Voltage Divider)
8A*	DCV	2V	0.00000***	Press Zero	0.00000 ± 1 digit	DC Calibrator
8B*	DCV	2V	-1.90000V	R381	-1.90000	DC Calibrator
9	DCV	20V	19.00000V	R307	19.0000 ± .5 digits	DC Calibrator
10	DCV	200V	190.0000V	R353	190.000 ± .5 digits	DC Calibrator
11	DCV	2000V	1000.000V	R308	1000.00 ± 2 digits	DC Calibrator
12	ACV	200V	100V at 50kHz	C412	100.000 ± 50 digits**	745 AC Calibrator
13	ACV	2000V	1000V at 1kHz	R401	1000.00 ± 4 digits	745 AC Calibrator/ Amplifier
14	ACV	2V	1V at 1kHz	R410	1.00000 ± 4 digits	745 AC Calibrator
15	ACV	20V	10V at 1kHz	R411	10.0000 ± 4 digits	745 AC Calibrator
16	ACV	200V	100V at 1kHz	R409	10.0000 ± 4 digits	745 AC Calibrator
17	ACV	200V	100V at 50kHz	C412	100.000 ± 9 digits	745 AC Calibrator
18	ACV	2V	1V at 50kHz	C411	1.00000 ± 9 digits	745 AC Calibrator
19	ACV	20V	10V at 50kHz	C408	10.0000 ± 9 digits	745 AC Calibrator

* Steps 8A and 8B must be performed for Rev. D and above Analog Boards (PC-560).

** Coarse Adjustment

*** Connect the DC Calibrator to the Model 192 so that it supplies negative voltage to the Model 192. Set the DC Calibrator for 0.00000 Volts.

Steps 4 through 6 are to be made with 4-terminals ohm measurement. The instrument must be rezeroed using the 4-terminal low thermal short to establish baseline before gain adjust.

Steps 12 through 19 require the Model 1910 ACV option to be installed in the Model 192. There is no need to proceed further than Step 11 if the Model 1910 is not installed.

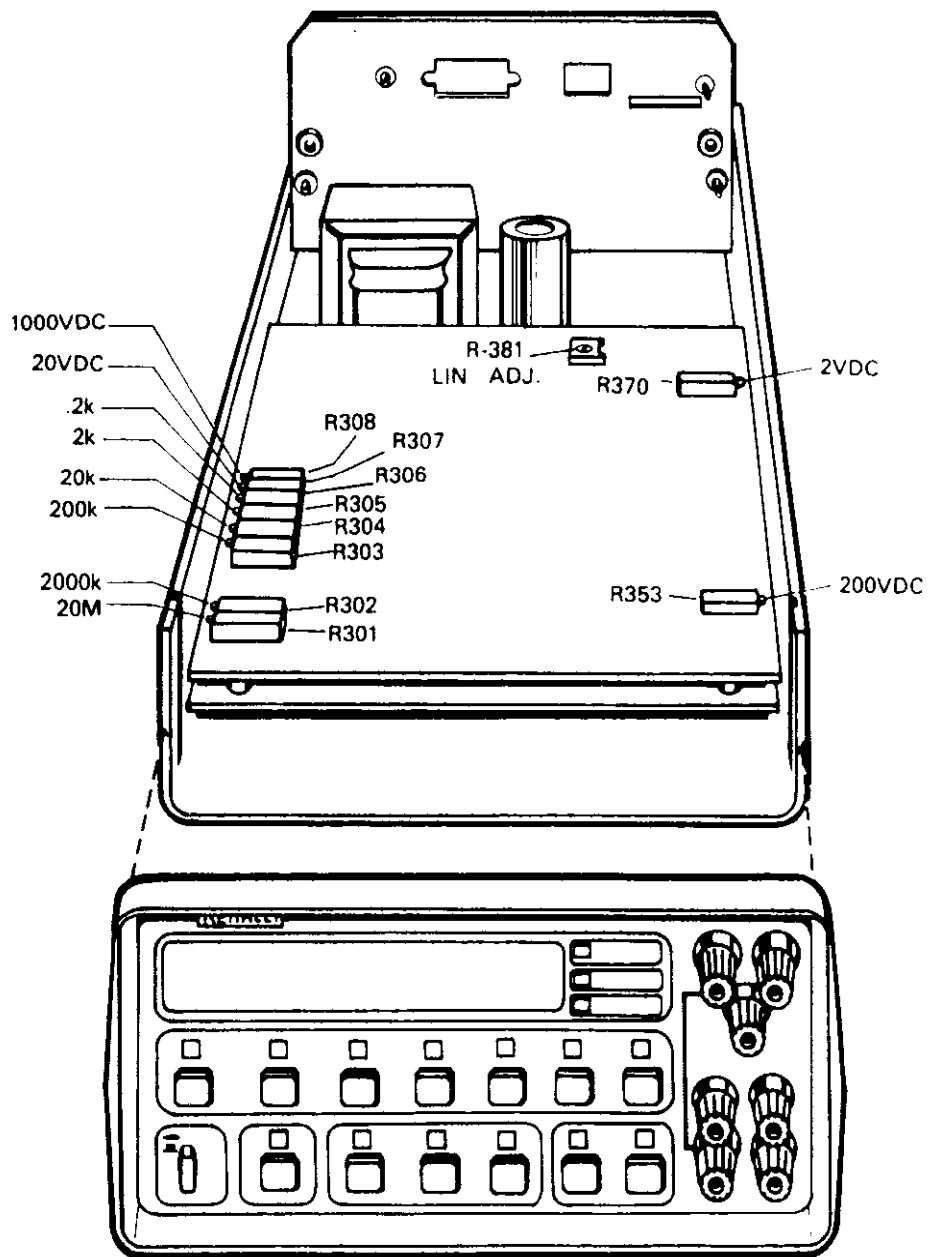

Figure 8-1. Adjustment Locations

1. Turn power off by depressing the Model 192 POWER button, and disconnect the line cord.
2. The fuse carrier is spring loaded. Using a slotted screwdriver, push the fuse carrier in and rotate ¼ turn counterclockwise. The carrier and fuse will eject from the holder.
3. Remove the fuse from the carrier and replace per Table 8-3.

CAUTION

Do not install fuse with higher rating than specified. Instrument damage may occur.

4. To install the fuse and carrier into the holder, reverse the procedure in step 2.

Table 8-3. Fuse Replacement

Line Voltage	Fuse F101	Keithley Part No.
90-125V	1/4A, 250V, 3AG, SLO BLO	FU-17
210-250V	1/8A, 250V, 3AG, SLO BLO	FU-20

8.3.2 Line Voltage Selection

Set up the Model 192 to operate on the available AC line voltage as follows:

WARNING

Turn off power and disconnect the line cord before removing the case cover.

1. Remove the top cover.
2. Refer to Table 8-4 and set switch S102 accordingly.
3. Install proper fuse per paragraph 8.3.1.

NOTE

The line voltage setting of the instrument is marked on the rear panel. The following procedure can be used either to confirm the factory setting, or to set up the instrument for operating on another voltage range. If the line voltage range is changed, the box next to the selected line voltage should be appropriately marked as an external reminder of the setting. Use a water soluble marking pen.

Table 8-4. Line Voltage Selection

Input Voltage	Line Frequency	Switch S102
105V-125V	50-400Hz	115V
210V-250V	50-400Hz	230V
*90V-110V	50-400Hz	115V
*195V-235V	50-400Hz	230V

*Requires special factory installed transformer.

8.3.3 Disassembly

If it is necessary to remove or replace a component, use the following disassembly procedure.

1. Remove the top cover as follows:

WARNING

Turn off power and disconnect the line cord before removing the case cover.

- A. Remove the two retaining screws located at the rear of the instrument.
 - B. Grasping the top cover at the rear, carefully lift it off the instrument.
 - C. When installing the top cover, make sure that the three tabs located at the front of the cover engage in the front panel assembly.
2. Remove the top shield from the Analog board by firmly lifting it off the four retaining slips. Refer to Figure 9-1. When replacing the top shield, do not pinch any wires in the retaining clips.
 3. If the AC option is installed, disconnect the brown and blue wires (P1014 and P1016) at the AC input and proceed as follows:
 - A. Unplug the option from the analog board (PC-560).
 - B. Detach shields from PC Board by removing the two retaining screws.
 - C. Refrain from any unnecessary touching of circuit components; handle the board by its edges.
 4. Remove the Analog board as follows:
 - A. Disconnect the input wires (white, green, gray, black and red) from the analog board (PC-560).
 - B. Remove the four screws retaining the analog board. Lift the analog board up and place it on the side of the Model 192.

NOTE

A fifth screw may be located at the rear of the analog board. This screw must also be removed to separate the analog board from the chassis.

5. If the Model 1923 IEEE option is installed, proceed as follows:
 - A. Unplug the Model 1923 ribbon cable from the motherboard (PC-559).
 - B. Remove the two screws holding the rear panel to the chassis.
 - C. Remove the two screws that hold the rear panel to the chassis (located under the Model 1923).
 - D. Lift the rear panel slightly and gently tap downward on the chassis until the rear panel is dislodged from the chassis. The Model 1923 will still be attached to the rear panel.
 - E. Carefully remove the display board (PC-530) ribbon cable from the display board.
 - F. Remove the mother board from the chassis by pulling the mother board toward the rear (away from the front

panel) being careful not to damage the power ON switch.

G. For reassembly, perform steps A through G in reverse order.

NOTE

Recalibration of the Model 1910 AC Voltage Option may be necessary if any of the following occurs:

1. Removal/replacement of the 1910.
2. Disturbing position of the 1910 in the connector.
3. Removal/replacement of shields on the 1910.

Refer to paragraph 6.5.3 to check AC voltage accuracy. If calibration is necessary perform steps 12 through 19 in Table 8-2.

8.3.4 Special Handling of Static Sensitive Devices

CMOS devices are designed to function at very high impedance levels for low power consumption. For this reason, a normal static charge build up on your person or clothing can be sufficient to destroy these devices. Table 8-5 lists the static sensitive devices in the Model 192 and the following steps provide instruction on how to avoid damaging them when they must be removed/replaced.

1. The integrated circuits listed in Table 8-5 should be handled and transported only in protected containers. Typically they will be received in static protected containers of plastic or foam. Keep the devices in their original containers until ready for use.
2. Remove the devices from their protective containers only at a properly grounded work bench or table, and only after grounding yourself by using a wrist strap.
3. Handle the devices only by the body. Do not touch the pins.
4. Any printed circuit board into which a device is to be inserted must also be grounded to the bench or table.
5. Use only anti-static type solder suckers.

Table 8-5. Static Sensitive Devices

Schematic Designation	Keithley Part Number
U103, U104	IC-251
U105	IC-135
U123, U124	LSI-15
U125	IC-197
U128	IC-250
U129	PRO-113-E5
U130	PRO-105, E5
U131	LSI-27
U132	LSI-28
U322	IC-168
Q304, Q307	TG-139
Q329-Q332	TG-139
Q335-Q338	TG-139

6. Use only grounded tip soldering iron.
7. After soldering the device into the board, or properly inserting it into the mating receptacle, the device is adequately protected and normal handling can be resumed.

8.4 TROUBLESHOOTING PROCEDURE

This section contains tables listing step-by-step checks of the major DMM circuits described in Section 7, Theory of Operation. The following paragraphs provide instructions for using these tables. Read this information carefully before troubleshooting.

The Model 192 has a unique self-test feature upon power up. This feature enables the operator or technician to make a better judgement in isolating the problem to the Analog or Digital portion of the DMM. Upon power up, all segments will be displayed momentarily as follows:

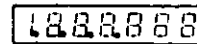

Immediately following, the operator will note on the display:

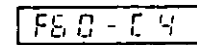

Where F60 is the line frequency (basic integration period)

F60 = 60Hz
F50 = 50Hz

C4 = Software Revision Level. (This number may differ with different instruments.)

When this initial indication is satisfactory, it is reasonable to assume the display and the microcomputer PROM memory are operating properly. This test enables the technician to isolate the problem within the Analog section of the Model 192. All ranges and functions can be tested via Program 8. When a specific range and function is selected, the program will step the Model 192 through a four sequence test which is the same step sequence the Model 192 uses to make a measurement. The major advantage of this program is that it allows the technician to control the stepping sequence in order to locate the problem. It also tests the display RAM and ROM circuitry.

To use Program 8, perform the following steps:

1. Press PRGM. The instrument will prompt for a program number as follows:



The question mark will flash.

2. Press 8. The instrument will display the program number for 1/2 second as follows:



3. After the program number, the instrument will perform a display, RAM, and ROM test for a few seconds. A properly operating display will appear as follows:

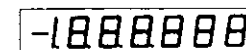

All front panel LEDs will also turn on.

- If the RAM and ROM pass their respective tests, the instrument will briefly display the following message:

PASS

If the RAM test fails, the following message will be displayed:

rAE

If the ROM test fails, the instrument will display the following:

rOE

- Regardless of the outcome of the preceding tests, the instrument will continue with Program 8 operation and prompt for a test number with the following message:

EESTP

The question mark will flash.

- A test number, 1-7, may be entered at this point by pressing the appropriate button. These tests are summarized in Table 8-6; note that tests 1 through 4 correspond to the N modes listed in Table 8-7 of the manual.
- If an invalid test number is entered (-, 0, 8, 9, ENT), the instrument will respond with the following message:

inPro

- Program 8 may be aborted at any time by pressing PRGM. To return the instrument to normal operation, press 0 after pressing the PRGM button.

Table 8-7 indicates which particular component (FET) is ON for a selected function and range as the program steps through the four parts of the test (N4 through N1, in descending order). The Model 192 will step to the next sequence of the test when any front panel switch is depressed. For example: After the microcomputer has been cleared, the 2VDC function and range have been selected, and test PROGRAM 8 has been entered; pressing a front panel button will hold the Model 192 in the N4 mode of the test. Refer to Table 8-7 and note that when the instrument is set at 2VDC and the N4 is entered, the gain of the Input Buffer (Amplifier) is 10. In addition, Q341 is the selected multiplexer FET that is switched ON. Scanning along N4 in that table, reveals that Q317 (Gain FET) and Q322 (Transconductance FET) are also ON.

This technique greatly simplifies the task of troubleshooting. Press another front panel button to step the Model 192 to the N3 mode. Notice that the multiplexer FET selected now is Q327.

8.4.1 Line Power

In general, start troubleshooting with Table 8-8 to verify that the power supplies are providing the correct voltages to the electronic components.

8.4.2 A/D Converter and Display

Verify proper operation of the A/D converter and display before troubleshooting the signal conditioning circuits. Check the A/D converter and display Tables 8-9 and 8-10 respectively.

8.4.3 AC Converter

Problems with AC voltage may involve the Model 1910 AC Voltage Option. Check this circuit per Table 8-11.

8.4.4 DC Attenuator, Ohms Source and Resistor

Problems with DC voltage or resistance ranges may involve these signal conditioning circuits. Check these circuits per Tables 8-12 and 8-13.

NOTE

Dust, flux, or other contamination will degrade performance on resistance and DC voltage ranges.

8.4.5 Digital Circuitry

Problems may exist with the microprocessor or associated circuitry. Check per Table 8-14.

All measurements are referenced to analog common (INPUT LO terminal), unless otherwise noted in the tables.

WARNING

Some procedures in the following tables require the use of high voltage. Take care to prevent contact with live circuits which could cause electric shock resulting in injury or death. The mother board shield is at INPUT LO potential. An input voltage floating high enough will create a shock hazard between the shield and earth ground.

Table 8-6. Test Number Summarization

Test Number	Test Function	Displayed Message	Comments
1-4	N modes 1-4	None	See Table 8-7 of manual.
5	ROM Test	PASS	Passed ROM test.
		rOE	Failed ROM test.
6	RAM Test	PASS	Passes RAM test.
		rAE	Failed RAM test.
7	Display Test	1888888	Will also turn on LEDs.

Table 8-7. Program 8 A/D Test—FET Switching Sequence

Function & Range	Mode	Input Buffer Gain	Multiplexer FET ON		Gain FET ON	Transconductance FET ON	Ω Range FET ON
			DCV	ACV			
1000V	N1	X1	Q328	Q311	Q319	Q322 ↓	
	N2	X1	Q341	Q312	↓		
	N3	X10	Q327	Q327	Q317		
	N4	X10	Q341	Q341	↓		
200V	N1	X10	Q328	Q311	Q317	Q322 ↓	
	N2	X10	Q341	Q312	↓		
	N3	X10	Q327	Q327	↓		
	N4	X10	Q341	Q341	↓		
20V	N1	X1	Q328	Q311	Q319	Q322 ↓	
	N2	X1	Q341	Q312	↓		
	N3	X10	Q327	Q327	Q317		
	N4	X10	Q341	Q341	↓		
2V	N1	X10	Q328	Q311	Q317	Q322 ↓	
	N2	X10	Q341	Q312	↓		
	N3	X10	Q327	Q327	↓		
	N4	X10	Q341	Q341	↓		
0.2V	N1	X10	Q328	Q311	Q317	Q322, Q323 ↓	
	N2	X10	Q341	Q312	↓		
	N3	X1	Q327	Q327	Q319		
	N4	X1	Q341	Q341	↓		
20M Ω	N1	X1	Q334		Q319	Q323 ↓	Q305 ↓
	N2	X1	Q339		↓		
	N3	X1	Q333		↓		
	N4	X1	Q310		↓		
2M Ω	N1	X1	Q334		Q319	Q323 ↓	Q301, Q305 ↓
	N2	X1	Q339		↓		
	N3	X1	Q333		↓		
	N4	X1	Q310		↓		
200k Ω	N1	X1	Q334		Q319	Q323 ↓	Q302, Q305 ↓
	N2	X1	Q339		↓		
	N3	X1	Q333		↓		
	N4	X1	Q310		↓		
20k Ω	N1	X1	Q334		Q319	Q323 ↓	Q306, Q307) ↓
	N2	X1	Q339		↓		
	N3	X1	Q333		↓		
	N4	X1	Q310		↓		
2k Ω	N1	X1	Q334		Q319	Q323 ↓	Q303, Q304 ↓
	N2	X1	Q339		↓		
	N3	X1	Q333		↓		
	N4	X1	Q310		↓		
0.2k Ω	N1	X10	Q334		Q317	Q323 ↓	Q308, Q309 ↓
	N2	X10	Q339		↓		
	N3	X10	Q333		↓		
	N4	X10	Q310		↓		

Table 8-8. Line Power Checks

Step	Item/Component	Required Condition	Remarks
1	A102 line switch	Must be set to 115V or 230V as appropriate.*	see paragraph 8.3.2
2	F101 line fuse	Continuity	see paragraph 8.3.1
3	P1011 line cord	Plugged into live receptacle	
4		Turn on power	
5	+5V Analog	+5V, $\pm 5\%$	P1009 pins 9 & 10, U127 Output
6	U127 Input	+7.4V minimum	Output of CR103
7	+5V Digital	+5V, $\pm 5\%$	J1010, pins 1,2 (IEEE connector)
8	Emitter of Q104	+6V minimum	Unregulated Input
9	+15V Analog	+15V $\pm 10\%$	P1009, pin 3, U111 output
10	U111 Input	+17.9V minimum	CR102 output
11	-15V	-15V, $\pm 10\%$	P1009-1, U112 output
12	U112 Input	-17.9V minimum	CR102 output
13	+30V	+30V, $\pm 10\%$	P1009-2, U113 output
14	U113 Input	+36V minimum	Output of CR101
15	-30V	-30V, $\pm 10\%$	P1009-4, U114 output
16	U114 Input	-36V minimum	Output of CR101

* On optional line voltage units set to 115V.

Table 8-9. A/D Converter Checks

Step	Item/Component	Required Condition	Remarks
1		Turn on power. Select 1000VDC.	Some tests here could fail due to Digital board problems and vice versa.
2	Display	000.00 ± 2 Digits	
3	U312 pin 12	0 to +4V square wave at 480kHz	480kHz clock
4	R326	20V for 16.6ms, 0V for 100ms	Input Buffer output
5	U308 pin 2	-2.5V, $\pm 7\%$ (175mV)	Transconductance Amp Bias
6	U316 pin 2	+5V, $\pm 7\%$ (350mV)	Charge Dispenser bias
7	C308 (in)	0V, ± 15 mV	Integrator input
8	C308 (out)	See waveform per Figure 7-14	Integrator output
9		Select 2VDC range	
10	External voltage source	Apply +1.90000V	Calibrated point
11	Display	1.90000 ± 10 digits	If different, check 2V reference Q327 (source)
12		Select 200mVDC range	
13	External voltage source	Apply .000000V	Calibrated point
14		Depress ZERO	
15	Display	00.000 ± 1 digit	Input offset nulled
16	External voltage source	Apply +190mV	Calibration point
17	Display	190.000 ± 10 digits	If different, check 0.2V reference or X10 gain of Input Buffer.

Table 8-10. Display Checks

Step	Item/Component	Required Condition	Remarks
1		Turn on power. Select 1000VDC range.	Initial power up test checks all digits.
2	+5V Digital U203 pins 2,9,14 or J1008, pin 14	+5V \pm 5%	If low, check per Table 8-6.
3	U203 pin 1		Update data
4	U203 pin 8		Clock input
5	U202 pins 4 and 5	Negative-going pulse (+5V to 0V) occurring every 400 μ sec. (2.5kHz).	

Table 8-11. AC Converter Checks (Model 1910)

Step	Item/Component	Required Condition	Remarks
1		Turn on power and select 2VDC range.	Full scale input on all ranges should produce approximately -2VDC at output. P1014 (brown wire) on the Analog Board
2		Short input	Do not perform unless A/D test are completed.
3	Display	.00020 \pm 10 digits	Normal zero offset range.
4*	Q311 source	10mV	Impedance meter to measure (> 10 ⁶ Ω). Output resistance is 300k Ω .
5*	Q312 source	Same as step 4, plus reading at step 3.	ACV Auto zero.
6	External voltage source	Apply 1.00000V rms at 1kHz	Calibration point.
7	Display	1.00000 \pm 100 digits	
8*	Q311 source	-1V, plus reading at step 4	DC output
9*	Q312 source	Same as step 5	Auto zero
10		Select 20VAC range	If any of above checks fail, proceed to bias checks step 18.
11	External voltage source	Apply 10.0000V rms at 1kHz	Calibration point
12	Display	10.0000 \pm 100 digits	Calibration point
13	External voltage source	Select 200VAC range and apply 100.000V rms.	
14	Display	100.000 \pm 100 digits	
15		Select 1000VAC range	
16	External voltage source	Apply 1000.00V rms	Calibration point
17	Display	1000.00 \pm 100 digits	
18**		TURN OFF POWER. Remove Model 1910 AC Voltage Option from Model 192. Remove shields and reinstall the 1910 in the 192. Select 2VAC range and short input. Turn on power.	With shields removed, display will be noisy and read many millivolts of AC pickup. Display will also change with operator movement.

Table 8-11. AC Converter Checks (Model 1910) (Cont.)

Step	Item/Component	Required Condition	Remarks
19	U401 Pin 2	0V \pm 10mV	Summing junction, AC amplifier
20	R405, CR401	0V \pm 10mV	DC output before filter
21	R402, R406	0V \pm 10mV	Feedback circuit
22	Q404, base	-7.5V \pm 10%	Base voltage
23	Q403, emitter	+5.7V \pm 10%	5 milliamp current source
24	Q401, base	-3.6V \pm 10%	Bias for C404 protection circuit.

*On Analog Board

** Model 1910 must be recalibrated if step 18 was performed.

Table 8-12. DC Attenuator Checks

Step	Item/Component	Required Condition	Remarks
1		Turn on power. Select 200VDC range.	These checks should not be made if a problem exists on the 200mVDC or 2VDC ranges.
2	External voltage	Apply +190.000V	Calibration point
3	Display	190.00 \pm 10 digits	100:1 Attenuator
4		Select 20VDC range	
5	External voltage source	Apply +19.0000V	Calibration point
6	Display	19.0000 \pm 10 digits	10:1 Attenuator
7		Select 1000VDC range	
8	External voltage source	Apply +1000.00V	Calibration point
9	Display	1000.00 \pm 5 digits	1000:1 Attenuator

Table 8-13. Ohms Source and Resistors Checks

Step	Item/Component	Required Condition	Remarks
1		Select 200 range and short input with 18 gauge (or lower) copper wire (tin plated okay).	Do not perform unless A/D converter and DC attenuator tests are completed.
2	Display	Less than 00.010	Two wire offset, including thermals
3	Q310, source	-0.4V \pm 9%	Ohms reference voltage
4	Q344, collector	-0.4V \pm 7%	Ohms reference divider
5		Select 2k Ω range	
6		.00000 \pm 2 digits	
7	Q310, source	-4V \pm 7%	Ohms reference voltage
8	Q344, collector	-4V \pm 7%	Ohms reference divider
9	1.00000k Ω	Apply to input (4-wire connection)	Calibrated resistance
10	Display	1.00000 \pm 10 digits	Range resistors
11	Q310, source	-4V \pm 7%	Ohms reference voltage
12	INPUT HI	-2V \pm 7% (half of step 11)	Voltage across unknown
13	10.0000k Ω	Apply to Input and select 20k Ω range	Calibrated resistance
14	Display	10.0000 \pm 10 digits	Range resistors
15		Repeat Steps 11 and 12	
16	100.000k Ω resistor	Apply to Input and select 200k Ω range.	Calibrated resistance
17	Display	100.000 \pm 10 digits	Range resistors
18		Repeat Steps 11 and 12	Use meter with high input impedance ($> 10^9\Omega$).
19	1.0000M Ω resistor	Apply to Input and select 2000k Ω range.	Calibrated resistance
20	Display	1.00000 \pm 30 digits	Range resistors
21		Repeat Step 18	Use meter with high input impedance ($> 10^9\Omega$).
22	10.000M Ω resistor	Apply to Input and select 20M Ω range.	Calibrated resistance
23	Display	10.0000 \pm 100 digits	Range resistors
24		Repeat Step 18	

Table 8-14. Digital Circuitry Checks

Step	Item/Component	Required Condition	Remarks
1		Turn on power. Select 1000VAC range*	Some tests here could fail because of A/D Converter problems and vice versa.
2	U131 pin 39	0 to +4V square wave at 4MHz	4MHz clock
3	U131 pin 37	0 to +4V square wave at 1MHz	1MHz clock
4	U122 pin 9	0 to +4V square wave at 1MHz	1MHz
5	U101 pin 5	0 to +4V square wave at 480kHz	480kHz clock
6	U106 pin 13	0 to +4V square wave at 2.4kHz	2.4kHz clock
7	U131 pin 40	+5V \pm 5%	Reset line
8	P1008 pin 15	Negative going pulse (+5V to 0V) occurring every 833 μ sec	Latch enable for Display Board (PB5)
9	P1008 pin 16	Negative going pulse (+5V to 0V) occurring every 100 μ sec	Clock input for Display Board (CA2)

SECTION 9 REPLACEABLE PARTS

9.1 INTRODUCTION

This section contains replacement parts information, schematic diagrams and component location drawings for the Model 192. Panel and Covers are shown separately in Figure 9-1.

9.2 PARTS LIST

Parts are listed alphabetically in order of their circuit designation. See Table 9-1.

9.3 ORDERING INFORMATION

To place an order or to obtain information concerning replacement parts, contact your Keithley representative or the factory. When ordering, include the following information:

1. Instrument Model Number
2. Instrument Serial Number
3. Part Description
4. Circuit Designation (if applicable)
5. Keithley Part Number

9.4 FACTORY SERVICE

If the instrument is to be returned to the factory for service, complete the service form which follows this section and return it with the instrument.

9.5 SCHEMATIC DIAGRAMS AND COMPONENT LOCATION DRAWINGS

Schematic diagrams and component location drawings follow the replaceable parts list information contained in this section. See Table 9-1.

Table 9-1. Model 192 Drawing Package

DESCRIPTION	SCHEMATIC	COMPONENT LAYOUT	ASSEMBLY
AC Converter	29960D	29955C	PC-496
Mother Board (Digital and Power Supplies)	30975D	30824D	PC-559
Analog Board	30976D	30831D	PC-560
Display Board	30974D	30823D	PC-530

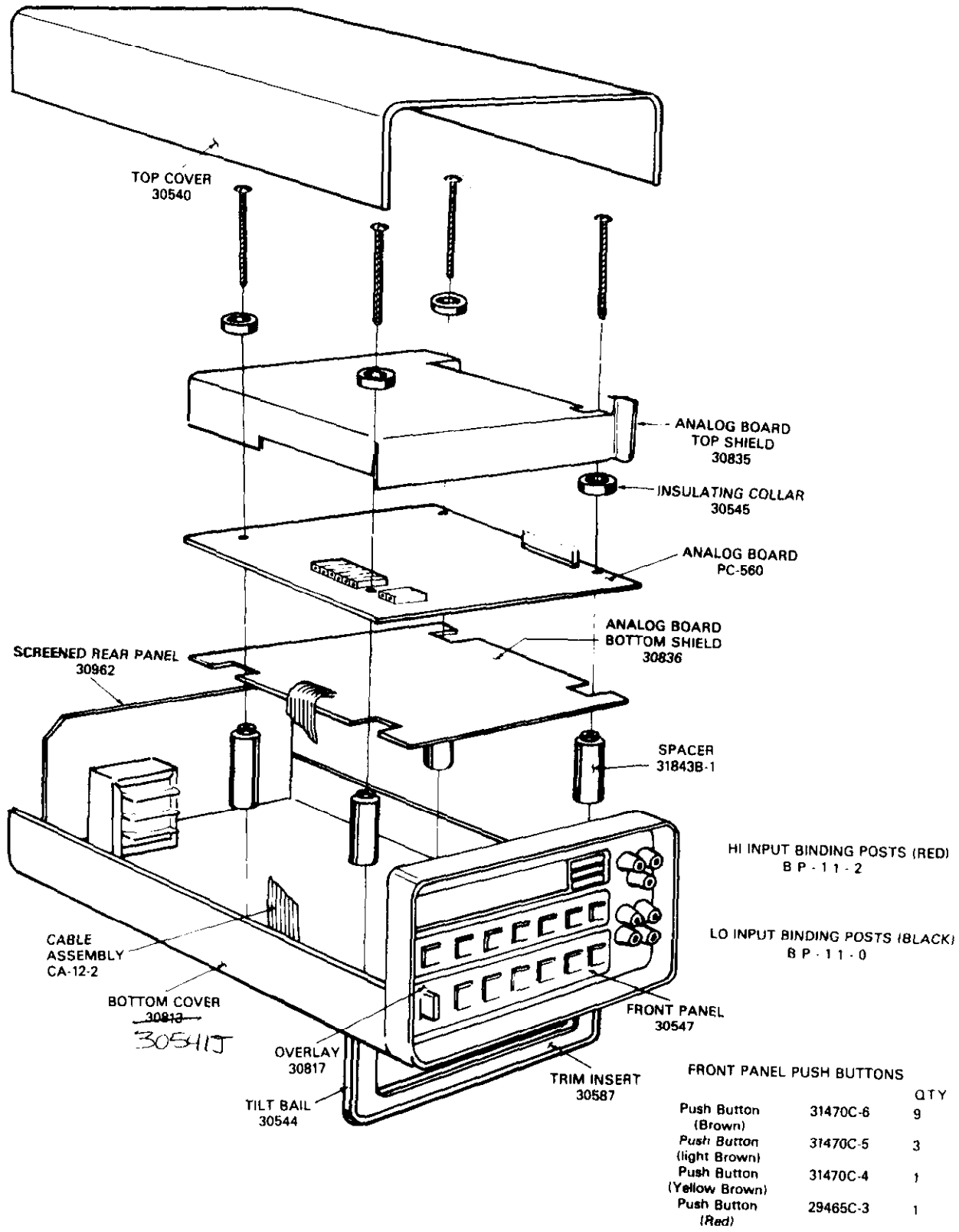

Figure 9-1. Exploded View With Mechanical Parts

Table 9-2. AC Converter PC-496, Parts List

Circuit Desig.	Description	Location		Keithley Part No.
		Sch.	Pcb.	
C401	.56 μ F, 50V, Metallized Polycarbonate	F3	5/B2	C-201-.56
C402	10 μ F, 20V, Aluminum Electrolytic	F4	6/B3	C-314-10
C403	3.3 μ F, 20V, Aluminum Electrolytic	F3	7/B3	C-321-3.3
C404	680 μ F, 3V, Tantalum	E4	8/B3	C-297-680
C405	.22 μ F, 50V, Metallized Polycarbonate	G3	9/B2	C-201-.22
C406	8820pF, 63V, Polystyrene	D6	10/B2	C-299-8820p
C407	418pF, 500VDC, Mica	D5	11/C2	C-278-418p
C408	Adjustable Capacitor, .8-18pF	D5	12/C2	C-225
C409	30pF, 500V, Mica	D4	13/C2	C-236-30p
C410	1.5pF, 50VDC, Tubular Ceramic	C4	14/D2	C-282-1.5p
C411	.25-1.5pF, 2000V, Trimmer	D4	15/D2	C-216
C412	.25-1.5pF, 2000V, Trimmer	B1	16/E2	C-216
C413	.1 μ F, 16VDC, Ceramic Disc	C1	17/D3	C-238-.1
C414	10 μ F, 20V, Aluminum Electrolytic	C2	18/D3	C-314-10
C415	.05 μ F, 1000V, Ceramic Disc	B2	19/E2	C-298-.05
C416	10pF, 1000V, Ceramic Disc	-	-	C-64-10p
CR401	Diode, Diffused, Silicon, 1N914	F2	24/B3	RF-28
CR402	Diode, Diffused, Silicon, 1N914	E2	25/B3	RF-28
CR403	Diode, Diffused, Silicon, 1N914	D2	26/B3	RF-28
CR404	Diode, Diffused, Silicon, 1N914	F5	27/B3	RF-28
CR405	Diode, Diffused, Silicon, 1N914	E5	28/B3	RF-28
CR406	Diode, Diffused, Silicon, 1N914	E5	29/B3	RF-28
CR407	Diode, Diffused, Silicon, 1N914	B2	30/D2	RF-28
CR408	Diode, Diffused, Silicon, 1N914	B2	31/E2	RF-28
J1006	Connector, Female, 12 Contacts	Sev	34/C3	CS-337-12
J1007	Lug, Receptacle	B2	35/F1	LU-90
J1008	Lug, Receptacle	C2	36/A3	LU-90
Q401	Transistor, NPN, Silicon, 2N5089	E4	45/A2	TG-62
Q402	Transistor, PNP, Silicon, 2N5087	E4	46/B2	TG-61
Q403	Transistor, PNP, Silicon, 2N5087	F2	47/B3	TG-61
Q404	Transistor, NPN, Silicon, 2N3904	D2	48/B3	TG-47
Q405	Transistor, PNP, Silicon, 2N3906	C2	49/C2	TG-84
R401	Pot, 50 Ω , 10%, $\frac{1}{4}$ W	F3	52/B2	RP-89-50
R402	249 Ω , .1%, 1/10W, Wire Wound	E4	53/B2	R-241-249
R403	2191 Ω , .1%, 1/10W, Wire Wound	F3	54/B2	R-241-2191
R404	150k Ω , 5%, $\frac{1}{4}$ W, Carbon or Composition	G2	55/B2	R-76-150k
R405	150k Ω , 5%, $\frac{1}{4}$ W, Carbon or Composition	F2	56/B2	R-76-150k
R406	10k Ω , 5%, $\frac{1}{4}$ W, Carbon or Composition	F4	57/B3	R-76-10k
R407	264.2 Ω , 5%, Part of a Matched Set	D6	58/B2	R-266
R408	240 Ω , 5%, $\frac{1}{4}$ W, Carbon or Composition	D2	59/B3	R-76-240
R409	Pot, 100 Ω , 10%, $\frac{1}{4}$ W	D5	60/B2	RP-89-100
R410	Pot, 10k Ω , 10%, $\frac{1}{4}$ W	D3	61/B2	RP-89-10k
R411	Pot, 1k Ω , 10%, $\frac{1}{4}$ W	D4	62/C2	RP-89-1k
R412	4.75k, .5%, Part of a Matched Set	C5	63/B2	R-266
R413	54.7k, .5%, Film	C4	64/B2	R-275-54.7k
R414	Thick Film, 5%, Resistor Network	Sev	65/C2	TF-72
R415	495k, .5%, Part of Matched Set	C3	66/C2	R-266
R416	33k Ω , 5%, $\frac{1}{4}$ W, Composition	D4	67/D2	R-76-33k
R417	47k Ω , 5%, $\frac{1}{4}$ W, Composition	B1	68/E2	R-76-47k
R418	2M Ω , .5%, Part of Matched Set	B2	69/E2	R-266
U401	Monolithic J-FET OP AMP, LF356	C2	72/D2	IC-152

*Manufacturers Designation includes Part Description; e.g., CR 25, 22, 5%.

**Manufacturers Designation is GP $\frac{1}{4}$, 1%, T100, Resistance Value.

Table 9-3. Mother Board PC-559, Parts List

Circuit Desig.	Description	Location		Keithley Part No.
		Sch.	Pcb.	
AT-101	Optical Isolator, 6N137	1/E2	B3	IC-292
AT-102	Optical Isolator, 6N137	1/E3	B3	IC-292
AT-103	Optical Isolator, 6N137	1/E3	C3	IC-292
AT-104	Optical Isolator, 6N137	1/E1	C3	IC-292
C-104	.1 μ F, 16V, Ceramic Disc	1/G3	7/B3	C-238-.1
C-105	.1 μ F, 16V, Ceramic Disc	1/F2	8/B3	C-238-.1
C-106	.1 μ F, 16V, Ceramic Disc	1/F3	9/B3	C-238-.1
C-107	.1 μ F, 16V, Ceramic Disc	1/F5	10/C3	C-238-.1
C-108	68pF, 1000V, Ceramic Disc	1/F6	11/C3	C-64-68p
C-109	47pF, 1000V, Ceramic Disc	1/F6	12/C3	C-64-47p
C-110	.1 μ F, 16V, Ceramic Disc	1/E6	13/D3	C-238-.1
C-111	.1 μ F, 16V, Ceramic Disc	1/F4	14/B3	C-238-.1
C-112	.1 μ F, 50V, Ceramic Disc	1/F4	15/B3	C-237-.1
C-113	10 μ F, 25V, Aluminum Electrolytic	2/D3	16/D2	C-314-10
C-114	10 μ F, 25V, Aluminum Electrolytic	2/D3	17/D2	C-314-10
C-115	10 μ F, 35V, Aluminum Electrolytic	2/D3	18/D2	C-309-10
C-116	10 μ F, 35V, Aluminum Electrolytic	2/D4	19/D3	C-309-10
C-117	470 μ F, 35V, Aluminum Electrolytic	2/C3	20/E1	C-289-470
C-118	470 μ F, 35V, Aluminum Electrolytic	2/D3	21/E2	C-289-470
C-119	470 μ F, 50V, Aluminum Electrolytic	2/C3	22/E2	C-292-470
C-120	470 μ F, 50V, Aluminum Electrolytic	2/D4	23/E3	C-292-470
C-121	2200 μ F, 25V, Aluminum Electrolytic	2/C2	24/E3	C-290-2200
C-122	10 μ F, 25V, Aluminum Electrolytic	2/D2	28/4E	C-314-10
C-123	.1 μ F, 50V, Ceramic Film	1/E6	26/B5	C-237-.1
C-126	6800pF, 500V, Ceramic Film	1/E5	29/C4	C-22-6800p
C-128	22pF, 1000V, Ceramic Film	1/B3	31/D4	C-64-22p
C-129	22pF, 1000V, Ceramic Film	1/B3	32/D4	C-64-22p
C-132	0.1 μ F, 50V, Ceramic Film	—	35/D4	C-237-.1
C-134	11,800 μ F, 25V, Aluminum Electrolytic	2/C5	37/E4	C-314-11600
C-135	2200pF, 500V, Ceramic Disc	2/D4	38/F4	C-22-2200p
C-137	470pF, 2000V, Ceramic Disc	N/A	40/E4	C-324-470p
C-138	470pF, 2000V, Ceramic Disc	N/A	41/F4	C-324-470p
C-139	.1 μ F, 50V, Ceramic Film	1/B1	42/C4	C-237-.1
C-140	.1 μ F, 50V, Ceramic Film	1/A3	43/F5	C-237-.1
C-141	4.7 μ F, 20V, Tantalum	1/A6	44/C5	C-179-4.7
C-142	.1 μ F, 50V, Ceramic Film	1/B6	45/B5	C-237-.1
C-143	.1 μ F, 50V, Ceramic Film	1/B6	46/B4	C-237-.1
C-144	.1 μ F, 50V, Ceramic Film	1/C5	171/D3	C-237-.1
C-145	.1 μ F, 50V, Ceramic Film	1/C6	172/D4	C-237-.1
C-146	.1 μ F, 50V, Ceramic Film	1/E3	173/B3	C-237-.1
C-147	.1 μ F, 50V, Ceramic Film	1/E6	174/E5	C-237-1.0
CR-101	RECTIFIER BRIDGE (1.5A), PF40	2/C3	49/F2	RF-46
CR-102	RECTIFIER BRIDGE (1.5A), PF40	2/C3	50/F2	RF-46
CR-103	RECTIFIER BRIDGE (5A), PE05	2/C2	51/F3	RF-48
CR-104	RECTIFIER BRIDGE (5A), PE05	2/C4	52/F4	RF-48
CR-105	Silicon Diode, 1N914,	2/E5	53/E4	RF-28
CR-106	Silicon Diode, 1N4607	2/D5	54/E4	RF-41
F-101	FUSE, 1/8 AMP (115V)	2/A4	62/G4	FU-17
F-101	FUSE, 1/8 AMP (230V)	2/A4	62/G4	FU-20
J-1008	CONNECTOR	—	—	30575A
J-1009	CONNECTOR	1/H1	72/2C, 2D	CS-389-2
J-1010	CONNECTOR	1/H1	73/F5	CS-389-1
J-1011	Power Connector	2/A5	74/G4	CS-388
L-101	100 μ H	1/F6	63/C3	CH-14
Q-101	N-Channel, J-FET, 4392	1/F6	77/D3	TG-77
Q-102	NPN, Silicon, 2N3904	1/D6	78/E5	TG-47
Q-103	NPN, Silicon, 2N3904	2/D5	79/E4	TG-47
Q-104	High Gain Darlington, D45E1	2/D4	80/F4	TG-127
R-101	10k, 5%, 1/4W, Composition	1/G4	85/B2	R-76-10k
R-102	10k, 5%, 1/4W, Composition	1/G1	86/B2	R-76-10k

Table 9-3. Mother Board PC-559, Parts List (Cont.)

Circuit Desig.	Description	Location		Keithley Part No.
		Sch.	Pcb.	
R-103	10k, 5%, ¼W, Composition	1/G1	87/D2	R-76-10k
R-104	220Ω, 5%, ¼W, Composition	1/E2	88/B3	R-76-220
R-105	220Ω, 5%, ¼W, Composition	1/E3	89/B3	R-76-220
R-106	220Ω, 5%, ¼W, Composition	1/E4	90/B3	R-76-220
R-107	220Ω, 5%, ¼W, Composition	1/F1	91/C3	R-76-220
R-108	22Ω, 5%, ¼W, Composition	1/F5	92/C3	R-76-22
R-109	10MEG, 10%, ¼W, Composition	1/F6	93/C3	R-76-10M
R-110	4.7k, 5%, ¼W, Composition	1/E6	94/B3	R-76-4.7k
R-111	4.7k, 5%, ¼W, Composition	1/E6	95/D3	R-76-4.7k
R-112	Thick Film Resistor Network	SEV	96/B4	TF-99
R-115	10k, 5%, ¼W, Composition	1/D5,E4	99/E4	R-76-10k
R-116	1k, 5%, ¼W, Composition	2/D5	100/E4	R-76-1k
R-117	1.5k, 5%, ¼W, Composition	2/D4	101/E4	R-76-1.5k
R-120	10k, 5%, ¼W, Composition	1/E6	104/E5	R-76-10k
R-121	4.7k, 5%, ¼W, Composition	1/D6	105/E5	R-76-4.7k
R-122	470Ω, 5%, ¼W, Composition	1/F2	106/B3	R-76-470
R-123	470Ω, 5%, ¼W, Composition	1/F3	107/B3	R-76-470
R-124	470Ω, 5%, ¼W, Composition	1/F4	108/B3	R-76-470
R-125	470Ω, 5%, ¼W, Composition	1/E1	109/C3	R-76-470
R-126	1M, 5%, ¼W, Composition	2/B5	110/E4	R-76-1M
R-127	5.36k, 1%, 1/8W, Film	—	111/E4	R-88-5.36k
R-128	243Ω, 1%, 1/8W, Film	—	163/E2	R-88-243
R-129	2.67k, 1%, 1/8W, Film	—	164/E3	R-88-2.67k
R-130	121Ω, 1%, 1/8W, Film	—	165/E3	R-88-121
R-131	3.3k, 5%, ¼W, Composition	—	166/E4	R-76-3.3k
R-132	10k, 5%, ¼W, Composition	—	169/B4	R-76-10k
R-133	Thick Film Resistor Network	—	170/D4	TF-101
S-101	Switch, Power	2/A4	112/B1	SW-426
S-102	Switch	2/A3	113/G1	SW-397
T-101	K-I Transformer	2/B,C	116/117	TR-180
		2,3,4	F2	TR-189
U-101	Dual 4 Bit Counter, 74LS393	1/G2		
		H6	119/B2	IC-213
U-102	Quad. 2-Input Nand Gate, 74LS00	F1,G2		
		H2	120/B2	IC-163
U-103	8 Bit Shift Register, MCI4894	1/H3	121/C2	IC-251
U-104	8 Bit Shift Register, MCI4094	1/F5	122/C2	IC-251
U-105	BCD to Decimal Decoder, CD4028	1/H4	123/D2	IC-135
U-106	Dual 4 Bit Counter, 74LS390	1/G6	124/B3	IC-212
U-107	Quad 2-Input And Gate, 74LS08	1/A2,A3,F2,F5	125/B3	IC-215
U-108	Dual "D" Flip-Flop, 74LS74	1/F3,G2	126/C3	IC-144
U-109	Quad 2-Input Nand Gate, 7400	1/F1,G1,G2	127/C3	IC-38
U-110	8 Bit Shift Register, MCI4094	1/G4	128/D3	IC-251
U-111	+ 15V Regulator, 78M15	2/D2	129/E1	IC-194
U-112	-15V Regulator, 79M15	2/D3	130/E2	IC-195
U-113	Regulator, LM317	2/D3	131/E2	IC-308
U-114	-24V Regulator, LM337	2/D4	132/E3	IC-309
U-120	Quad Exclusive OR Gate, 7486	1/E1,E4	138/B4	IC-116
U-121	Dual 2 to 4 Line Decoder, 74LS139	1/D3	139,C4	IC-182
U-122	Quad 2-In Nand Gate, 74LS00	1/D5,E5,C3	140/C4	IC-163
U-123	1024 × 4 Bit Static Ram, 2114	1/D5	141/D4	LSI-15
U-124	1024 × 4 Bit Static Ram, 2114	1/C6	142/D4	LSI-15
U-125	Oscillator/Clock, MC4060	1/E4	143/E4	IC-197
U-126	Up/Down Counter, 74C193	1/E4	144/E4	IC-310
U-127	+ 5V Regulator, 7805	2/D2	145/F3	IC-93
U-128	Bus Driver, MC14503	1/D6	146/B4	IC-250
U-129	K-I Programmed ROM	1/B5	147/C4	PRO-113-E5
U-130	K-I Programmed ROM	1/B5	148/C5	PRO-105-E5
U-131	Microprocessor, MC6808	1/B2	149/D4	LSI-27
U-132	Interface Adapter, SY6522	1/C2	150/D5	LSI-28
U-133	5V Regulator, 78605	2/D4	151/F4	IC-223
Y-101	3.84 MHZ Crystal	1/F6	167/C3	CR-13
Y-102	4.0 MHZ Crystal	1/B3	168/D4	CR-10

Table 9-4. Analog Board PC-560, Parts List

Circuit Desig.	Description	Location		Keithley Part No.
		Sch.	Pcb.	
C-301	68pF 5% 500V Polystyrene	2/B1	7/C2	C-138-68p
C-302	330pF 5% 500V Polystyrene	2/C2	8/C2	C-138-330p
C-303	6800pF 20% 500V Ceramic Disc	2/C5	1/C3	C-22-6800p
C-304	6800pF 20% 500V Ceramic Disc	2/C5	2/C3	C-22-6800p
C-305	1000pF 5% 500V Polystyrene	1/D1	11/C4	C-138-1000p
C-307	150pF 10% 100V Ceramic Disc	2/G5	13/D4	C-64-150p
C-308	3600pF 5% 500V Polystyrene	2/F2	14/F4	C-138-3600p
C-310	1000pF 500V Polystyrene	1/D2	16/C4	C-138-1000p
C-311	.1μF 16V Ceramic Disc	1/D6	17/F5	C-238-.1
C-312	1000pF 500V Polystyrene	1/A3	18/B4	C-138-1000p
C-313	.1μF 16V Ceramic Disc	1/D6	19/F5	C-238-.1
C-314	1.5pF, 50V, Tubular Ceramic			C-282-1.5pF
C-315	.1μF, 50V, Ceramic Film			C-237-.1
CR-301	Diode Current Unit, J505	2/B4	24/D3	TG-140
CR-302	Diode Current Unit, J505	2/B5	25/D3	TG-140
CR-305	Diode, 1N914	1/D1	28/C4	RF-28
CR-306	Diode, 1N914	2/G5	29/D4	RF-28
K-301	Relay 2PDT	1/D1	190/C4	RL-51
P-1009	Cable Assembly	A5,B1		
		E4,E5	36/D1	CA-12-2
P-1012	Connector	1/B2	37/D5	29995A
P-1014	Connector	1/D2	39/C4	CS-357
Q-301	N-Channel FET	1/B4	43/B3	31841A
Q-302	N-Channel FET	1/B4	44/B3	31841A
Q-303	N-Channel FET	1/C4	45/B3	31841A
Q-304	N-Channel FET, PF5301	1/C4	46/B2	TG-139
Q-305	N-Channel FET, 2N4392	1/B4	47/C3	TG-128
Q-306	N-Channel FET	1/B4	48/C2	31841A
Q-307	N-Channel FET, PF5301	1/C4	49/C2	TG-139
Q-308	N-Channel FET	1/D4	50/C2	31841A
Q-309	N-Channel FET, PF5301	1/D4	51/C2	TG-139
Q-310	N-Channel J-FET	1/G3	52/C3	30966A
Q-311	N-Channel J-FET	1/F2	53/C3	30966A
Q-312	N-Channel J-FET	1/F2	54/C3	30966A
Q-313	Selected low leakage Transistors	1/D4	55/C3	28234A
Q-314	NPN Silicon, 2N5551	2/B4	56/D3	TG-67
Q-315	PNP Silicon, 2N4355	2/B5	57/D3	TG-90
Q-316	NPN Silicon, 2N5551	2/B3	58/D3	TG-67
Q-317	N-Channel J-FET	2/B2	59/D3	30966A
Q-318	N-Channel J-FET	2/B4	60/D3	30966A
Q-319	N-Channel J-FET	2/B2	61/D3	30966A
Q-321	N-Channel FET, 2N4392	2/E1	63/E3	TG-128
Q-322	N-Channel FET, 2N4392	2/D2	64/F2	TG-128
Q-323	N-Channel FET, 2N5432	2/D1	65/F2	TG-151
Q-325	N-Channel FET, 2N4392	2/G6	67/E4	TG-128
Q-327	N-Channel J-FET			30966A
Q-328	N-Channel J-FET	1/F2	70/C4	30966A
Q-329	N-Channel J-FET PF5301	1/D1	71/C4	TG-139
Q-330	N-Channel J-FET PF5301	1/D1	72/C4	TG-139
Q-331	N-Channel J-FET PF5301	2/A2	73/C4	TG-139
Q-332	N-Channel J-FET PF5301	2/A1	74/C4	TG-139
Q-333	N-Channel J-FET	1/G2	75/C3	30966A
Q-334	N-Channel J-FET	1/G2	76/C4	30966A
Q-335	N-Channel J-FET PF5301	1/E3	77/C4	TG-139
Q-336	N-Channel J-FET, PF5301	1/E3	78/B3	TG-139
Q-337	N-Channel J-FET, PF5301	1/D3	79/B3	TG-139
Q-338	N-Channel J-FET, PF5301	1/D3	80/B4	TG-139
Q-339	N-Channel J-FET	1/G2	81/C4	30966A
Q-340	Selected Device	1/D3	82/C4	28234A

Table 9-4. Analog Board PC-560, Parts List (Cont.)

Circuit Desig.	Description	Location		Keithley Part No.
		Sch.	Pcb.	
Q-341	N-Channel J-FET	1/F2	83/C4	30966A
Q-342	NPN, MPS-U95	1/D1	84/D4	TG-133
Q-343	NPN Silicon, 2N5551	1/F3	85/D4	TG-67
Q-344	NPN HI Volt Silicon, TIP-49	2/G5	86/D5	TG-137
Q-345	Selected Device	2/F5	87/E4	28234A
Q-346	NPN Silicon, 2N3904	2/F2	88/F4	TG-47
Q-347	PNP Silicon, 2N3906	2/G2	89/F4	TG-84
Q-348	PNP Silicon, 2N3906	2/G2	90/E5	TG-84
Q-349	PNP Silicon 2N5087	2/D4	91/F5	TG-61
Q-350	PNP Silicon, 2N5087	2/D5	92/F5	TG-61
R-301	50k Cermet Pot	1/A4	105/B2	RP-89-50k
R-302	5k Cermet Pot	1/B4	106/B2	RP-89-5k
R-303	500Ω Cermet Pot	1/B4	107/C2	RP-89-500
R-304	50Ω Cermet Pot	1/B4	108/C2	RP-89-50
R-305	200k Cermet Pot	1/C4	109/C2	RP-89-200k
R-306	20k Cermet Pot	1/D4	110/C2	RP-89-20k
R-307	100Ω Cermet Pot	2/C2	111/C2	RP-89-100
R-308	100Ω Cermet Pot	2/C2	112/C2	RP-89-100
R-309	1.108M .1% ¼W Metal Film	1/B3	113/B2	R-264-1.108M
R-310	140k 1% 1/8W Metal Film	1/C3	114/B2	R-88-140k
R-311	1.005k .1% 1/10W Metal Film	1/C3	115/C2	R-263-1.005k
R-312	100.7k .1% 1/10W Metal Film	1/B3	116/C2	R-263-100.7k
R-313	9.98k .1% 1/10W Metal Film	1/B3	117/C2	R-263-9.98k
R-314	100.5 .1% 1/10W Metal Film	1/D3	118/C2	R-263-100.5
R-315	13.3k 1% 1/8W Metal Film	1/D3	119/C2	R-88-13.3k
R-316	1k 1% ¼W Composition	2/B1	120/C2	R-76-1k
R-317	Matched set with R319	2/C3	121/C2	R-292-8k
R-318	100k 1% ¼W Composition	2/B1	122/C2	R-76-100k
R-319	Matched set with R317	2/C2	123/C2	R-292-72.2k
R-320	1M, 5% ¼W Composition	2/B3	124/D2	R-76-1M
R-321	1M, 5% ¼W Composition	2/B4	125/D2	R-76-1M
R-322	Thick Film Resistor Network	D1-3,E2,3	26/E3	TF-111
R-323	100k 1% ¼W Composition	2/D3	127/F2	R-76-100k
R-324	100k 1% ¼W Composition	2/D2	128/F2	R-76-100k
R-326	50k .1% 1/10W Metal Film	2/D1	130/F2	R-263-50k
R-328	Thick Film Resistor Network	2/E1,F1-4	132/F3	TF-85
R-330	1M 5% ¼W Composition	2/B2	134/D3	R-76-1M
R-332	200k 1% ¼W Composition	2/B3	136/D3	R-76-200k
R-333	10Ω 1% ¼W Composition	2/B4	137/D3	R-76-10
R-334	10Ω 1% ¼W Composition	2/B5	138/D3	R-76-10
R-335	1M 5% ¼W Composition	1/G3	139/C3	R-76-1M
R-336	1M 5% ¼W Composition	1/F3	140/C3	R-76-1M
R-338	1M 5% ¼W Composition	1/F3	142/C3	R-76-1M
R-339	300k 5% ¼W Carbon	1/C5	143/C4	R-282-300k
R-340	300k 5% ¼W Composition	1/D4	144/C3	R-282-300k
R-341	Thick Film Resistor Network	1/A4-6,B4-6	145/B3	TF-108
R-342	1M 5% ¼W Composition	1/G3	146/B3	R-76-1M
R-343	1M 5% ¼W Composition	1/G3	147/B3	R-76-1M
R-344	9.99M .1% Metal Film	1/A4	148/B3	R-294-9.99M
R-345	300k 5% ¼W Composition	1/D4	149/B4	R-282-300k
R-346	300k 5% ¼W Composition	1/D3	150/B4	R-282-300k
R-347	1M 5% ¼W Composition	1/G3	151/B4	R-76-1M
R-348	300k 5% ¼W Composition	1/C3	152/B4	R-282-300k
R-349	300k 5% ¼W Composition	1/D2	153/C4	R-282-300k
R-350	200k 1% 1/8, Metal Film	1/A1	154/C4	R-247-200k
R-351	100k 5% ¼W Composition	1/B2	155/C5	R-282-100k
R-352	Thick Film Resistor Network	1/A2,1-2	156/C5	TF-83
R-353	200Ω Cermet Pot	1/B2	157/B5	RP-89-200
R-354	1M 5% ¼W Composition	1/F3	158/C4	R-76-1M
R-356	1M 5% ¼W Composition	1/F3	160/C4	R-76-1M

Table 9-4. Analog Board PC-560, Parts List (Cont.)

Circuit Desig.	Description	Location		Keithley Part No.
		Sch.	Pcb.	
R-357	1M 5% ¼W Composition	1/G3	181/C4	R-76-1M
R-359	Thick Film Resistor Network	SEV	183/D4	TF-109
R-360	200k 1% ¼W Composition	1/F3	184/D4	R-76-200k
R-361	Thick Film Resistor Network	—	185/D4	TF-105
R-362	220k 10% ½W Composition	2/G4	186/E4	R-1-220k
R-363	100k, 10%, 1W, Composition	2/G4	187/E4	R-2-100k
R-364	1M 5% ¼W Composition	2/G6	188/E4	R-76-1M
R-367	Selected	1/C5	171/E5	Selected
R-368	Selected	1/C5	172/E5	Selected
R-369	Thick Film Resistor Network	—	173/F5	TF-110
R-370	20Ω Cermet Pot	1/C6	174/E5	RP-89-20
R-371	Resistor set 45.9k	1/C5	175/E5	R-293-45.9k
R-372	Resistor set 20k	1/C6	176/E5	R-293-20k
R-376	2.67k 1% 1/8W Metal Film	2/G6	180/E4	R-88-2.67k
R-377	60.4k 1% 1/8W Metal Film	2/F5	181/D4	R-88-60.4k
R-378	40.2k 1% 1/8W Metal Film	2/F6	182/D4	R-88-40.2k
R-379	100k 2W 10% Composition	1/B1	183/C4	R-3-100k
R-380	899 .1% 1/10W, Metal Film	1/A2	184/B5	R-263-899
R-381	100k Pot	2/F2	185/F4	RP-97-100k
R-382	3.3M 5% ¼W Composition	2/E2	186/F3	R-76-3.3M
U-301	OP-AMP Selected	2/A1	192/C3	30167A
U-302	OP-AMP, LF356	2/A5	193/D3	IC-152
U-303	OP-AMP, LM343	2/B1	194/C2	IC-254
U-304	Quad Comparator, LM339	1/F5	195/D2	IC-219
U-305	Quad Comparator, LM339	SEV	196/D2	IC-219
U-306	Quad Comparator, LM339	SEV	197/E2	IC-219
U-307	J-FET Input OP-AMP, LF351	2/D3	198/E2	30154A
U-308	J-FET Input OP-AMP, LF351	2/E2	199/F3	30154A
U-309	Comparator, LM311	2/F3	200/F3	IC-173
U-310	Transistor Package, CA3086	E1,F1,F3	201/E3	29198A
U-311	Transistor Package, CA3086	SEV	202/E3	29198A
U-312	Quad 2-in. NOR Gate, 74L502	SEV	203/E4	IC-179
U-313	J-FET Input OP-AMP, LF351	2/F2	204/F4	IC-176
U-314	Dual "D" Flip-Flop, 74574	G2,H2	205/F4	IC-216
U-315	J-FET Input OP-AMP, LF351	1/C5	206-F4	30154A
U-316	J-FET Input OP-AMP, LF351	2/D4	207/F5	30154A
U-317	Voltage Reference	1/D6	208/F5	29996
U-318	Quad Comparator, LM339		209/D3	IC-219
U-319	Quad Comparator, LM339		210/D4	IC-219
U-320	J-FET Input OP-AMP, LF351	2/G5	211/D4	30154A
U-321	Quad Comparator, LM339		212/D4	IC-219
U-322	BCD to Seven Seg Driver, 4511	1/C1	213/C5	IC-188
UR-301	6.3V Zener	2/B4	222/B4	DZ-58
UR-302	6.3V Zener	2/B5	223/D4	DZ-58
UR-303	9.1V Zener	1/D1	224/D4	DZ-14
V-301	Jumper	2/C4	229/D3	J-3
V-302	Jumper	2/C5	230/D3	J-3
V-303	Jumper	1/C5	231/D4	J-3
V-304	Jumper	1/D5	232/D4	J-3
V-305	Jumper	1/D5	233/D4	J-3

Table 9-5. Display Board PC-530, Parts List

Circuit Desig.	Description	Location		Keithley Part No.
		Sch.	Pcb.	
C-210	10 μ F, 20V, Alum Elect	D5	3/D3	C-179-10
DS-201	" \pm " Digital Display	B2	8/B2	DD-31
DS-202	"8" Digital Display	C2	9/B2	DD-30
DS-203	"8" Digital Display	C2	10/B2	DD-30
DS-204	"8" Digital Display	D2	11/C2	DD-30
DS-205	"8" Digital Display	D2	12/C2	DD-30
DS-206	"8" Digital Display	E2	13/C2	DD-30
DS-207	"8" Digital Display	E2	14/C2	DD-30
DS-208	Pilot Light	E2	15/D2	PL-67
DS-207	Pilot Light	E2	16/D2	PL-67
DS-210	Pilot Light	E2	17/D2	PL-67
DS-211	Pilot Light	H3	18/B3	PL-67
DS-212	Pilot Light	H3	19/B3	PL-67
DS-213	Pilot Light	G3	20/B3	PL-67
DS-214	Pilot Light	G3	21/C3	PL-67
DS-215	Pilot Light	G3	22/C3	PL-67
DS-216	Pilot Light	G3	23/D3	PL-67
DS-217	Pilot Light	F3	24/D3	PL-67
DS-218	Pilot Light	F3	25/B3	PL-67
DS-219	Pilot Light	F3	26/B3	PL-67
DS-220	Pilot Light	G3	27/C3	PL-67
DS-221	Pilot Light	H3	28/C3	PL-67
DS-222	Pilot Light	G3	29/D3	PL-67
Q-201	PNP SIL Transistor, 2N4355	G4	33/D2	TG-90
Q-202	PNP SIL Transistor, 2N4355	G4	34/D2	TG-90
Q-203	PNP SIL Transistor, 2N4355	H4	35/D2	TG-90
Q-204	PNP SIL Transistor, 2N4355	H4	36/D2	TG-90
Q-205	PNP SIL Transistor, 2N4355	G4	37/D2	TG-90
Q-206	PNP SIL Transistor, 2N4355	F4	38/D2	TG-90
Q-207	PNP SIL Transistor, 2N4355	F4	39/C3	TG-90
Q-208	PNP SIL Transistor, 2N4355	G4	40/D2	TG-90
R-201	Thick Film Resistor Network	F4,G4,H4	46/C2	TF-165-1
R-202	Thick Film Resistor Network	F5,G5,H5	47/D2	TF-77
S-201	Switch	B4	51/B3	SW-435
S-202	Switch	A4	52/B3	SW-435
S-203	Switch	A4	53/B3	SW-435
S-204	Switch	B4	54/C3	SW-435
S-205	Switch	B4	55/C3	SW-435
S-206	Switch	A4	56/D3	SW-435
S-207	Switch	A4	57/D3	SW-435
S-208	Switch	B4	58/B3	SW-435
S-209	Switch	A3	59/B3	SW-435
S-210	Switch	A3	60/C3	SW-435
S-211	Switch	B3	61/C3	SW-435
S-212	Switch	B3	62/D3	SW-435
S-213	Switch	B4	63/D3	SW-435
U-201	MOS to LED Segment Driver, 75492	B3, 4, C3, D3	67/B3	IC-169
U-202	MOS to LED Segment Driver, 75492	B4, D4, E4, F4	68/C3	IC-169
U-203	Bit Shift Register, 74LS164	C5	69/C3	IC-127

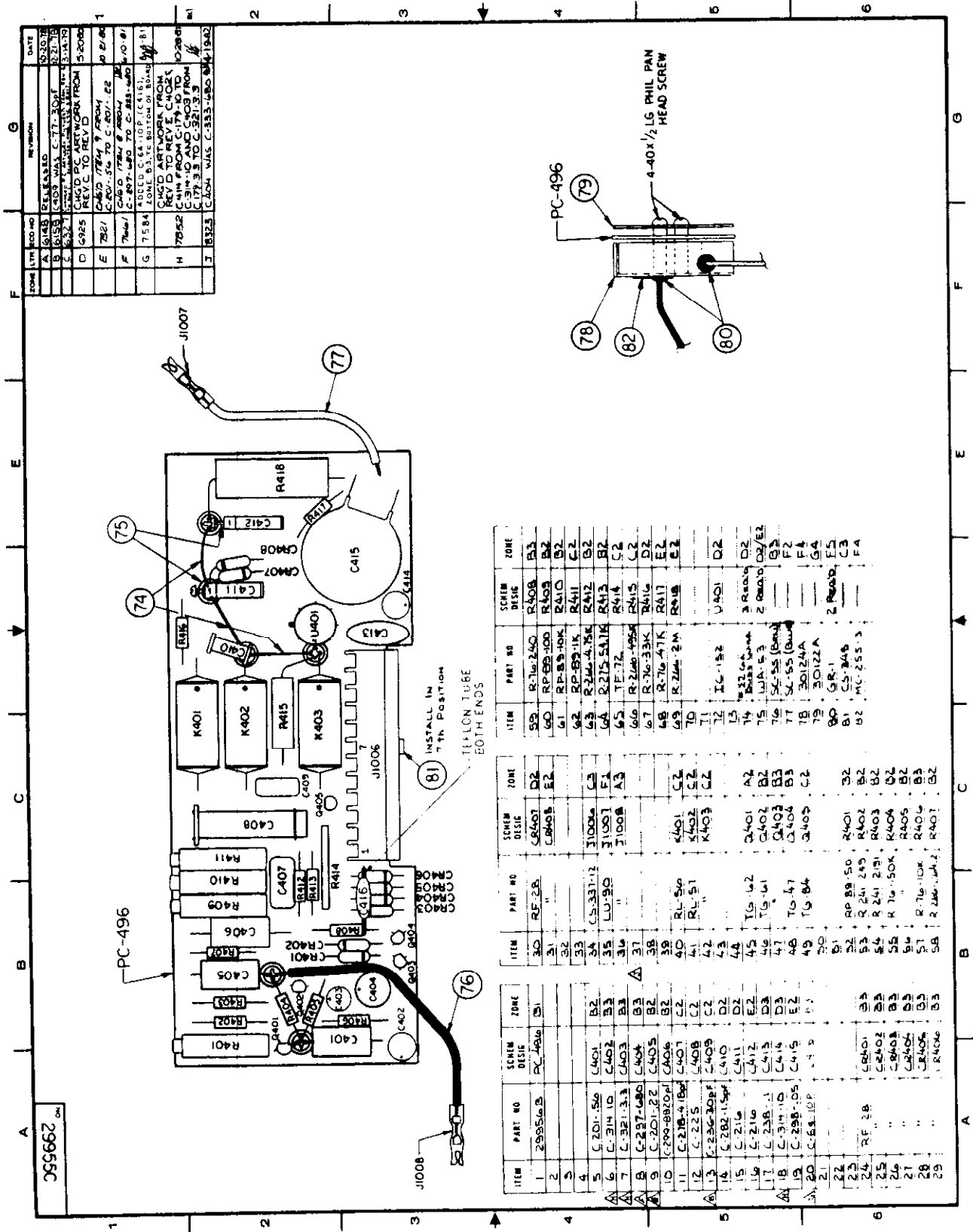

ZONE	LTN	REV. NO.	REVISION	DATE
A	G148		RELEASED	10-20-72
B	G158		CHG. WAS. C-77-207F	12-17-72
C	G162		CHG. WAS. C-77-207F	12-17-72
D	G925		CHG. WAS. C-77-207F	5-20-68
E	7227		CHG. 17741 9 FROM	4-2-68
F	7644		CHG. 17741 9 FROM	10-10-67
G	7584		CHG. 17741 9 FROM	10-10-67
H	7852		CHG. ARTWORK FROM	10-28-68
I	8323		CHG. WAS. C-383-480	11-18-62

ITEM	PART NO.	SCHEM. DESIG.	ZONE	ITEM	PART NO.	SCHEM. DESIG.	ZONE
1	299555B	PC-496	B1	30	RF-28	C401	B2
2			B2	31		C402	B3
3			B3	32		C403	B3
4	C-201-56	C401	B2	33	C-5331-12	I100A	C3
5	C-314-10	C402	B3	34	LU-20	I100B	A3
6	C-321-33	C403	B3	35			
7	C-297-680	C404	B3	36			
8	C-201-22	C405	B2	37			
9	C-299-820A	C406	B2	38			
10	C-218-108	C407	C2	39	RL-540	K401	C2
11	C-225	C408	C2	40	RL-51	K402	C2
12	C-236-202F	C409	C2	41		K403	C2
13	C-282-159F	C410	D2	42		K404	C2
14	C-216	C411	D2	43			
15	C-216	C412	E2	44			
16	C-216	C413	D3	45	TG-142	Q401	A2
17	C-238-1	C414	D3	46	TG-141	Q402	B2
18	C-314-10	C415	D3	47		Q403	B3
19	C-298-05	C415	E2	48	TG-47	Q404	B3
20	C-64-10P		F3	49	TG-84	Q405	C2
21				50			
22				51	RP-89-50	R401	B2
23				52	R-241-245	R402	B2
24	RF-28		B3	53	R-241-219	R403	B2
25			B3	54	R-76-150K	R404	B2
26			B3	55	R-76-150K	R405	B2
27			B3	56	R-76-150K	R406	B2
28			B3	57	R-76-150K	R407	B2
29			B3	58	R-241-245	R407	B2

Figure 9-2. AC Converter, Component Location Drawing, Dwg. No. 29955

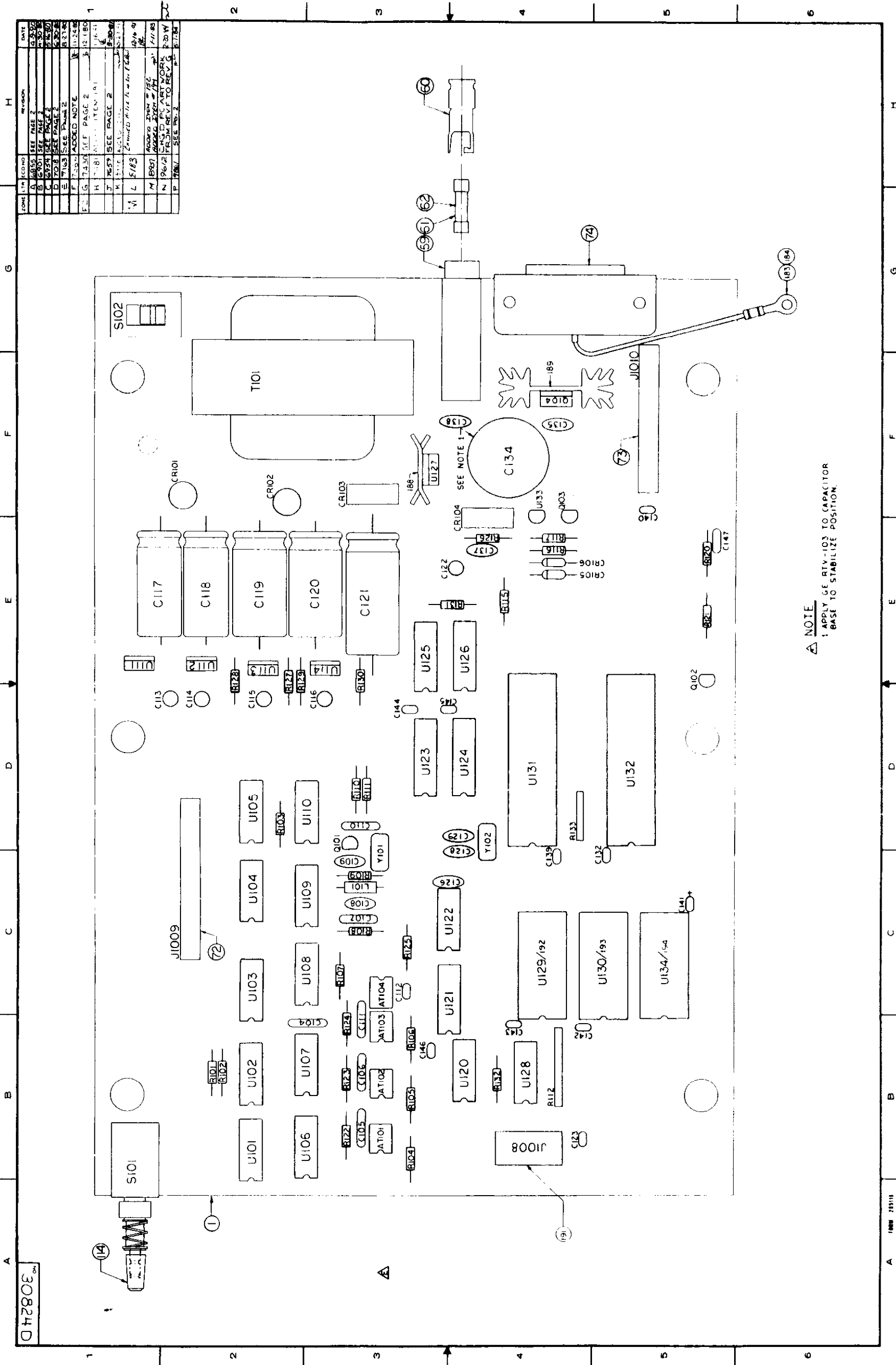
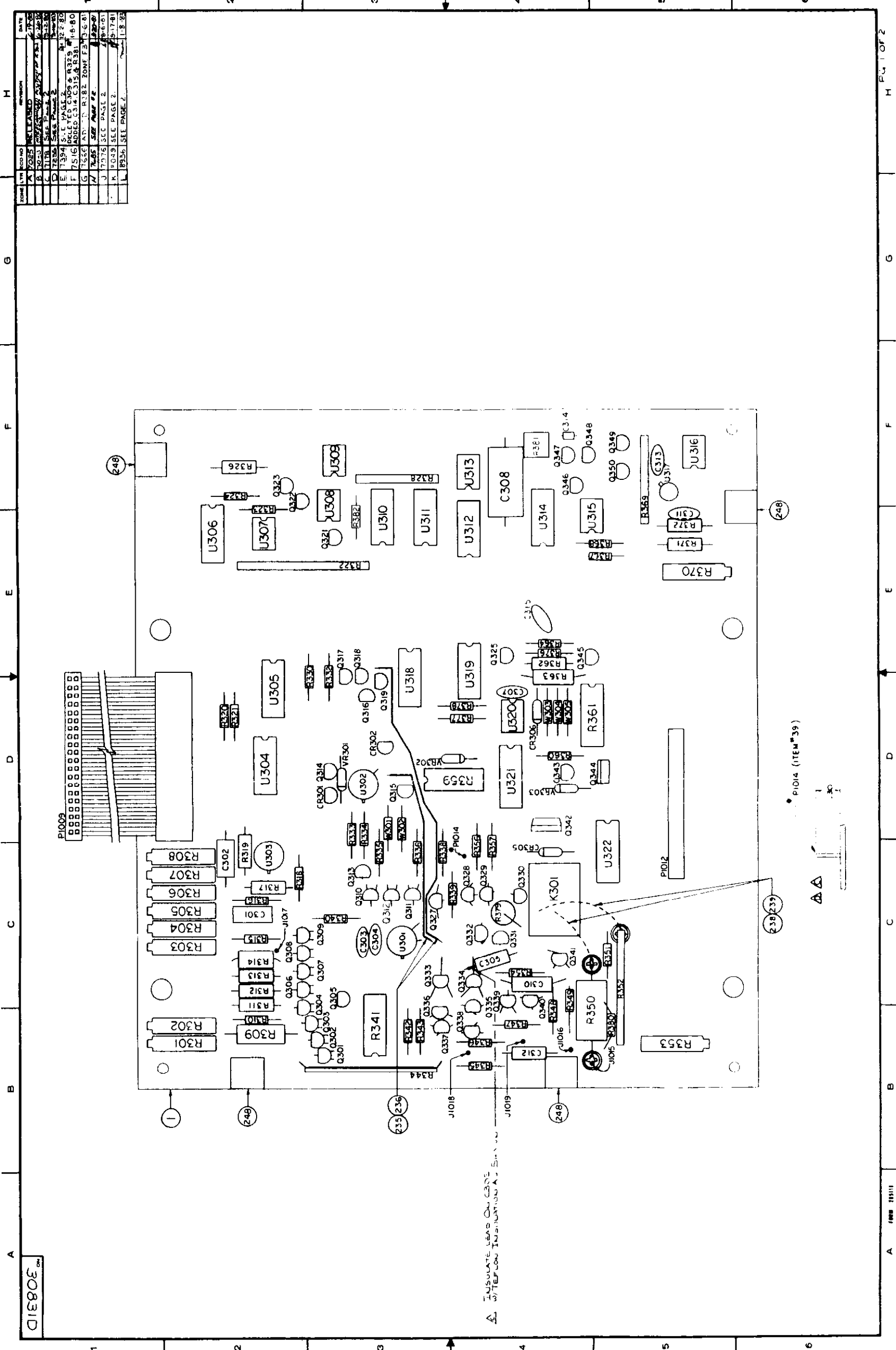

Figure 9-3. Mother Board, Component Location Drawing. Dwg. No. 30824 (sheet 1 of 2)



ZONE	REV	DESCRIPTION	DATE
A	002	RELEASED	7-7-82
B	001	REVISED TO ADD P1009	7-7-82
C	001	SEE PAGE 2	7-7-82
D	001	SEE PAGE 2	7-7-82
E	001	SEE PAGE 2	7-7-82
F	001	SEE PAGE 2	7-7-82
G	001	SEE PAGE 2	7-7-82
H	001	SEE PAGE 2	7-7-82
I	001	SEE PAGE 2	7-7-82
J	001	SEE PAGE 2	7-7-82
K	001	SEE PAGE 2	7-7-82
L	001	SEE PAGE 2	7-7-82

Figure 9-4. Analog Board, Component Location Drawing, Dwg. No. 30831 (sheet 1 of 2)

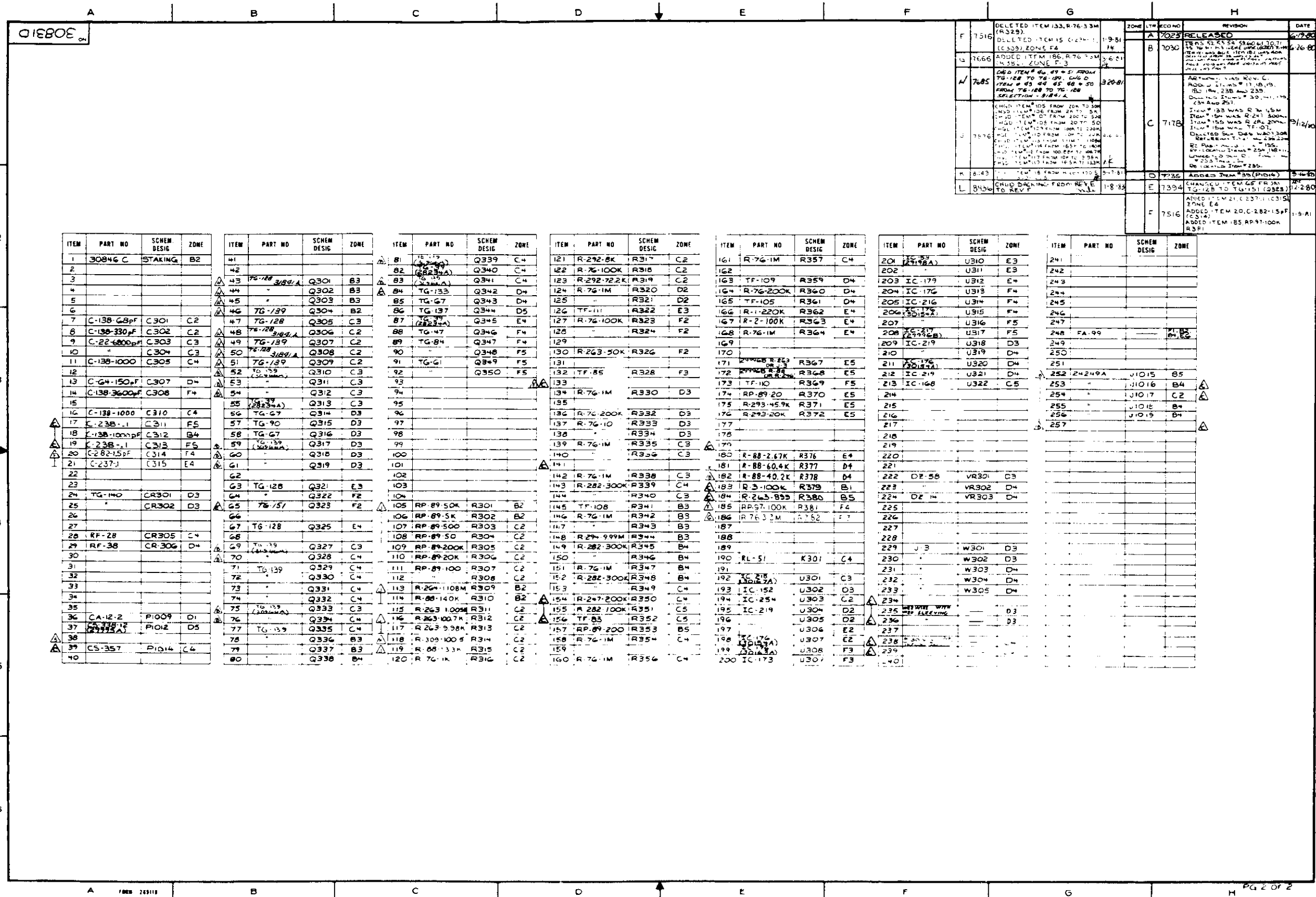
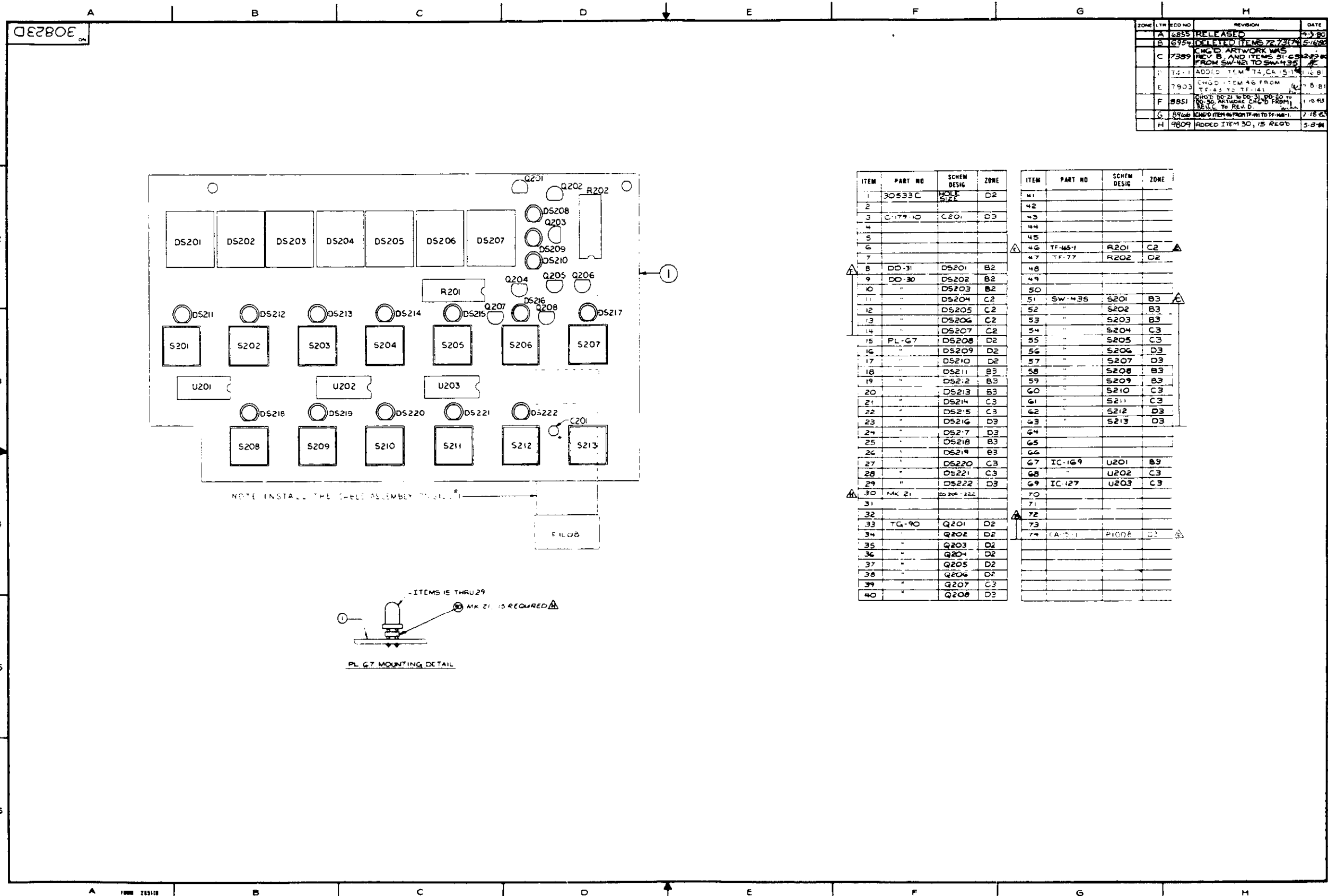

Figure 9-4. Analog Board. Component Location Drawing, Dwg. No. 30831 (sheet 2 of 2)



ZONE	ITEM	REV. NO.	REVISION	DATE
A	6855		RELEASED	3-3-80
B	6954		DELETED ITEMS 22, 23 (2)	5-16-80
C	7389		CHGD ARTWORK WAS REV B, AND ITEMS 51, 52, 53, 54, 55, 56, 57, 58, 59, 60, 61, 62, 63, 64, 65, 66, 67, 68, 69 FROM SW-435 TO SW-435	7-18-80
D	7411		ADDED ITEM 74, CA 15-14	10-8-81
E	7903		CHGD ITEM 46 FROM TF-43 TO TF-141	11-18-83
F	8851		CHGD DS-21 TO DS-31, DS-30 TO DS-30, AND CHGD FROM REV C TO REV D	1-18-83
G	8966		CHGD ITEM NUMBER TF-43 TO TF-44-1	7-18-83
H	9809		ADDED ITEM 30, 15 RELO	3-8-84

ITEM	PART NO	SCHEM DESIG	ZONE
1	30533C	HOLE SIZE	D2
2			
3	C-179-10	C201	D3
4			
5			
6			
7			
8	DO-31	DS201	B2
9	DO-30	DS202	B2
10		DS203	B2
11		DS204	C2
12		DS205	C2
13		DS206	C2
14		DS207	C2
15	PL-G7	DS208	D2
16		DS209	D2
17		DS210	D2
18		DS211	B3
19		DS212	B3
20		DS213	B3
21		DS214	C3
22		DS215	C3
23		DS216	D3
24		DS217	D3
25		DS218	B3
26		DS219	B3
27		DS220	C3
28		DS221	C3
29		DS222	D3
30	MK 21	DS208-222	
31			
32			
33	TG-90	Q201	D2
34		Q202	D2
35		Q203	D2
36		Q204	D2
37		Q205	D2
38		Q206	D2
39		Q207	C3
40		Q208	D3

ITEM	PART NO	SCHEM DESIG	ZONE
41			
42			
43			
44			
45			
46	TF-46-1	R201	C2
47	TF-77	R202	D2
48			
49			
50			
51	SW-435	S201	B3
52		S202	B3
53		S203	B3
54		S204	C3
55		S205	C3
56		S206	D3
57		S207	D3
58		S208	B3
59		S209	B3
60		S210	C3
61		S211	C3
62		S212	D3
63		S213	D3
64			
65			
66			
67	IC-169	U201	B3
68		U202	C3
69	IC-127	U203	C3
70			
71			
72			
73			
74	CA-5-1	PI008	D1

Figure 9-5. Display Board. Component Location Drawing. Dwg. No. 30823

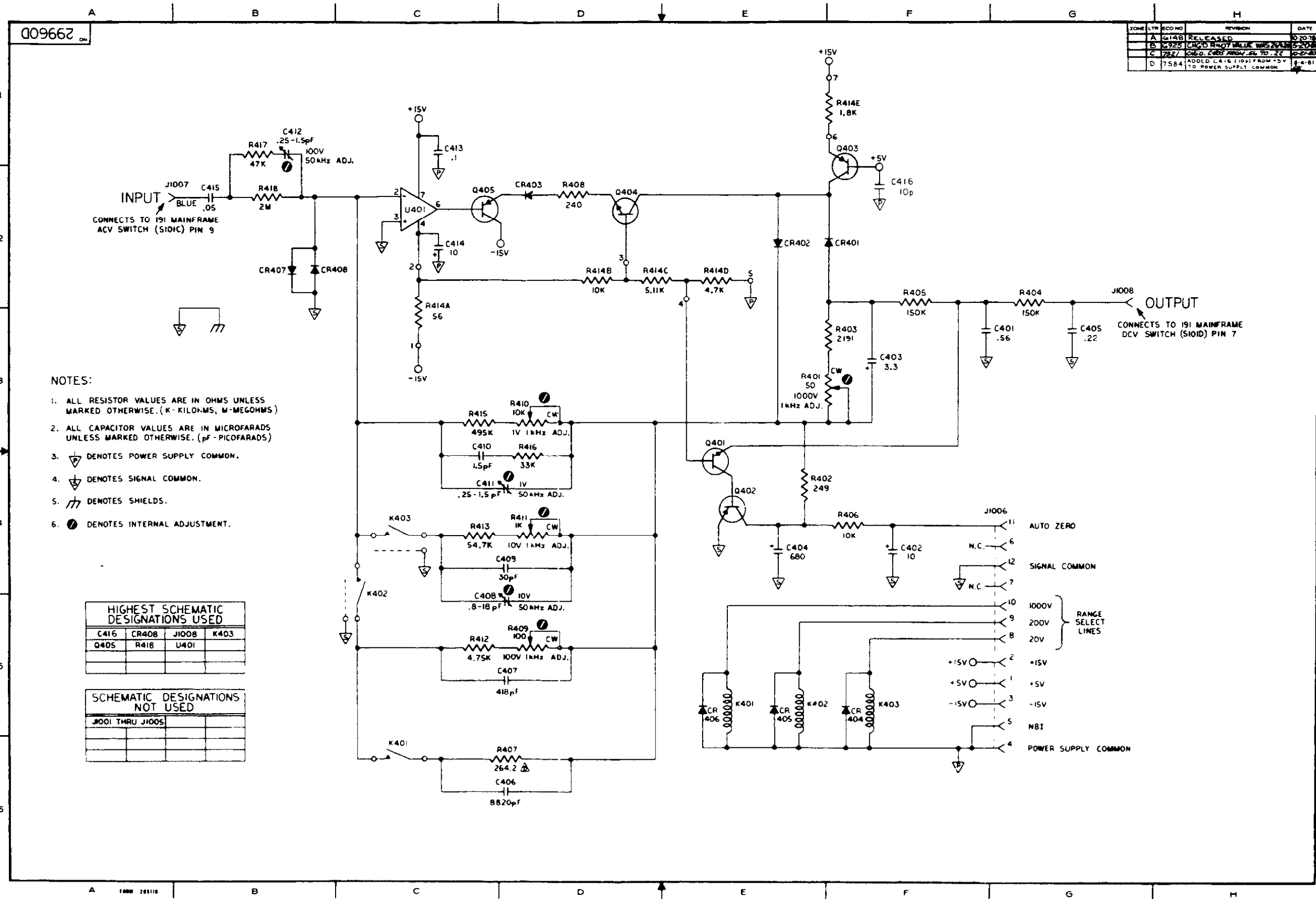
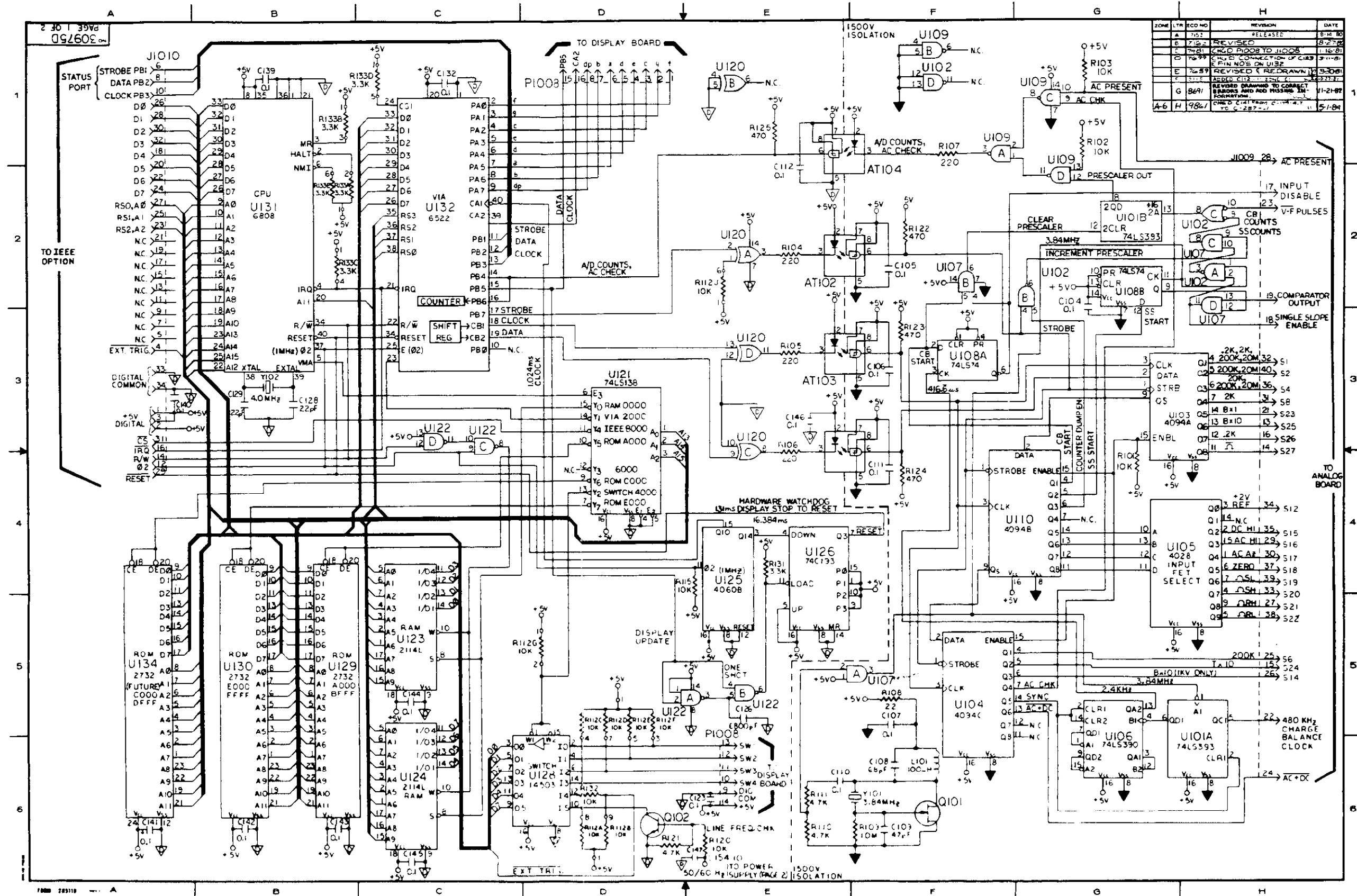

Figure 9-6. AC Converter, Schematic Diagram, Dwg. No. 29960



ZONE	TR	ECO NO	REVISION	DATE
A	1	153	RELEASED	8-10-80
B	1	153	REVISED	8-27-80
C	1	7481	CHG'D PROOB TO J1008	1-16-81
D	1	7489	CHG'D CONNECTION OF C183	3-11-81
E	1	7489	FIN NOS ON U132	3-11-81
F	1	7489	REVISED & RE-DRAWN	3-22-81
G	1	7489	ADDED C113 33K C114 22K	3-22-81
H	1	7489	REVISED DRAWING TO CORRECT BRASS AND ADD MISSING IN CONNECTION	11-21-81
A-B	1	7489	CHG'D C113 FROM 33K TO 22K	5-1-84

Figure 9-7. Mother Board Schematic Diagram, Dwg. No. 30975 (sheet 1 of 2)

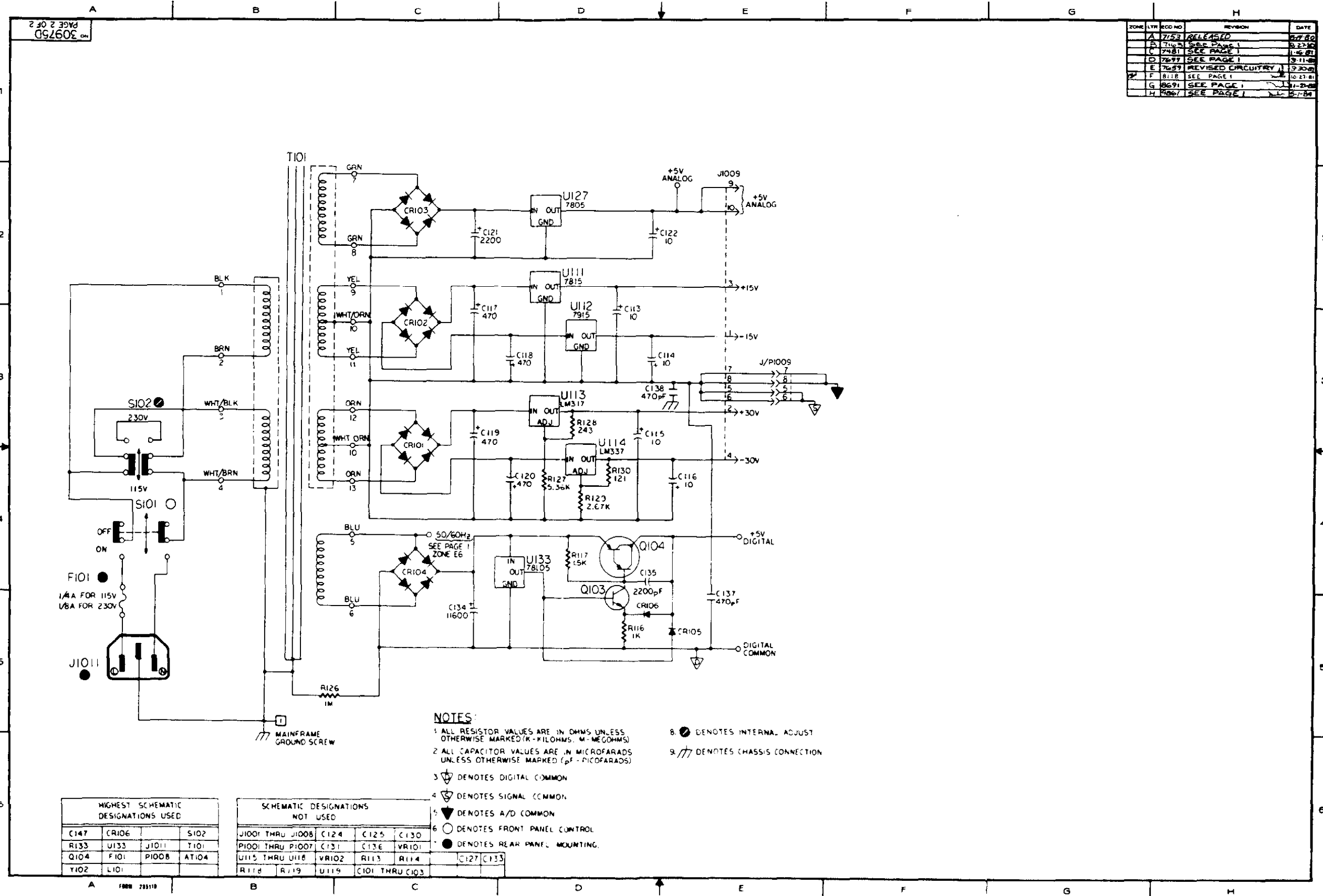

Figure 9-7. Mother Board, Schematic Diagram, Dwg. No. 30975 (sheet 2 of 2)

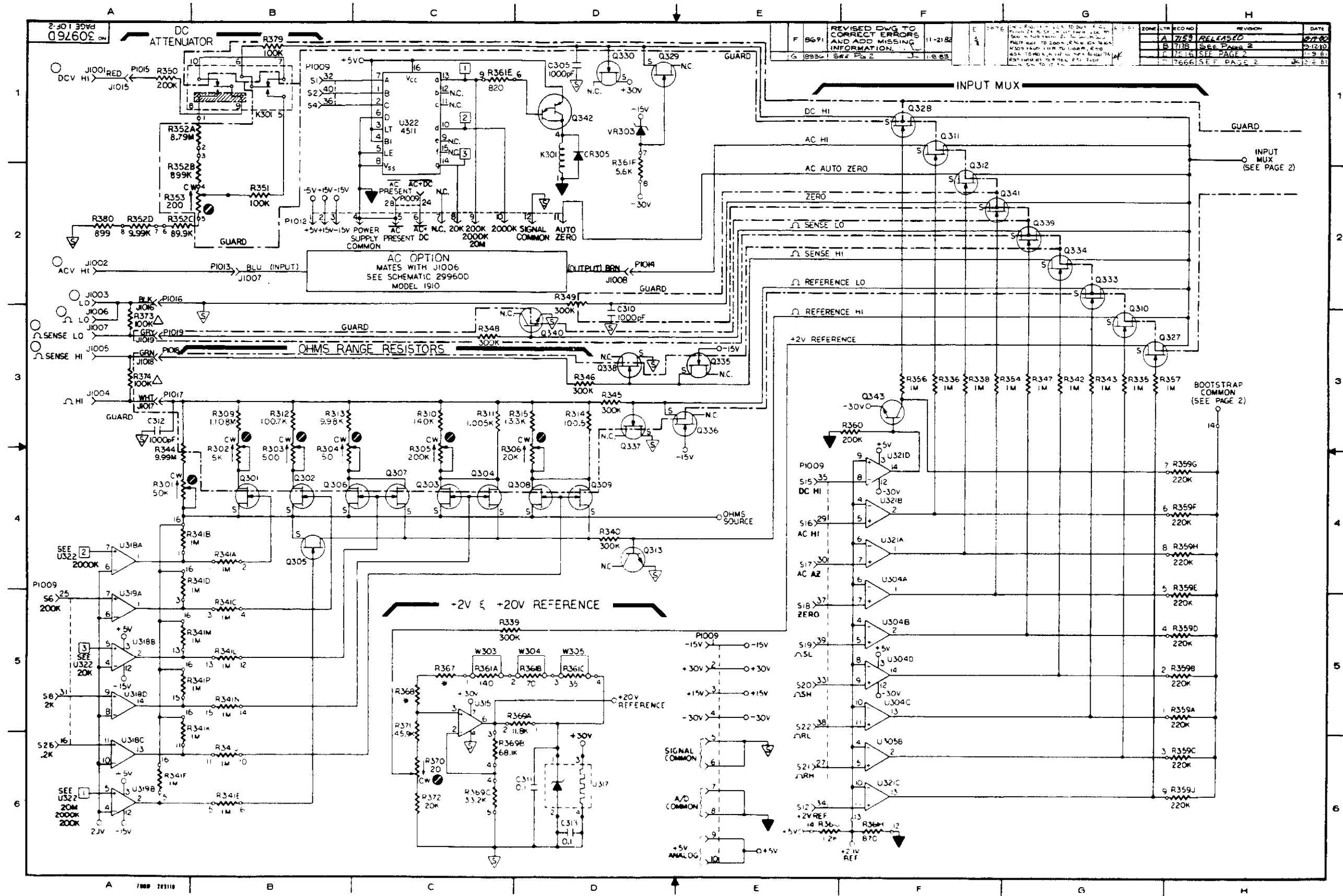

Figure 9-8. Analog Board, Schematic Diagram. Dwg. No. 30976 (sheet 1 of 2)

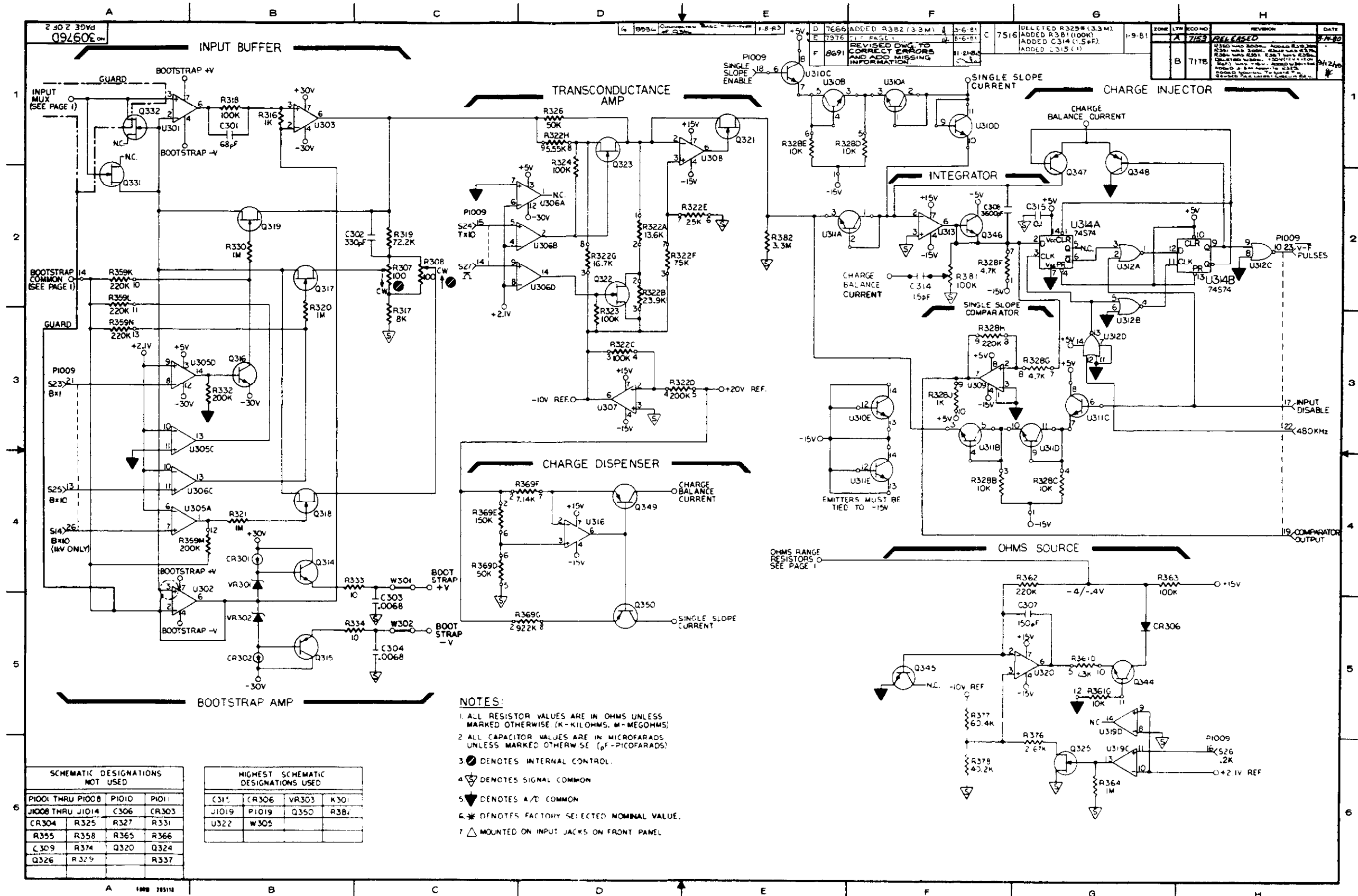

Figure 9-8. Analog Board, Schematic Diagram, Dwg. No. 30976 (sheet 2 of 2)

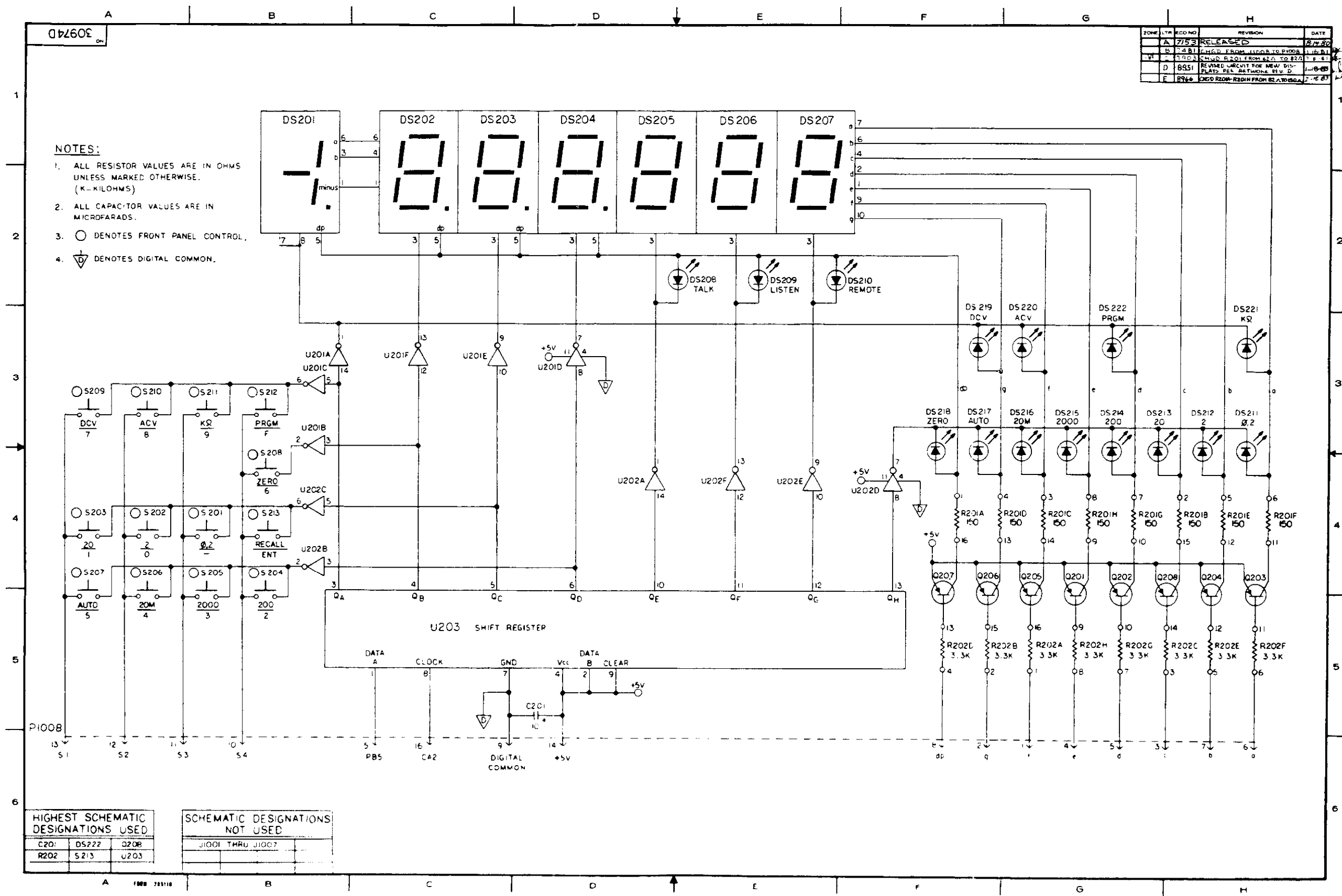

Figure 9-9. Display Board. Schematic Diagram. Dwg. No. 30974



SERVICE FORM

Model No. _____ Serial No. _____ P.O. No. _____ Date _____

Name _____ Phone _____

Company _____

Address _____

City _____ State _____ Zip _____

List all control settings and describe problem. _____

(Attach additional sheets as necessary.)

Show a block diagram of your measurement system including all instruments connected (whether power is turned on or not). Also describe signal source.

Where is the measurement being performed? (factory, controlled laboratory, out-of-doors, etc.) _____

What power line voltage is used? _____ Variation? _____

Frequency? _____ Ambient Temperature? _____ °F.

Variation? _____ °F. Rel. Humidity? _____ Other? _____

Any additional information. (If special modifications have been made by the user, please describe below.)

*Be sure to include your name and phone number on this service form.

KEITHLEY

Test Instrumentation Group, Keithley Instruments, Inc. • 28775 Aurora Road • Cleveland, Ohio 44139 • (216) 248-0400 • Fax: (216) 248-6168

CHINA: Keithley Instruments, Inc. • Holiday Inn Lido • Office Building 404C • Beijing, China, 100004 • 8610-436-2871/2860 • 8610-436-2871
FRANCE: Keithley Instruments SARL • 3 Allée des Garays • B.P. 60 • 91122 Palaiseau Cédex • 01-60-11-51-55 • Fax: 01-60-11-77-26
GERMANY: Keithley Instruments GmbH • Landsberger Str. 65 • 82110 Germering • 089-849307-0 • Fax: 089-84930759
GREAT BRITAIN: Keithley Instruments, Ltd. • The Minster • 58 Portman Road • Reading, Berkshire RG30 1EA • 01734-575666 • Fax: 01734-596469
ITALY: Keithley Instruments SRL • Viale S. Gimignano 38 • 20146 Milano • 02-48303008 • Fax: 02-48302274
JAPAN: Keithley Instruments Far East KK • Sumiyoshi 24 Bldg., Room 201 • 2-24-2 Sumiyoshi-cho • Naka-ku, Yokohama 231 • 81-45-201-2246 • Fax: 81-45-201-2247
NETHERLANDS: Keithley Instruments BV • Avelingen West 49 • 4202 MS Gorinchem • Postbus 559 • 4200 AN Gorinchem • 01830-35333 • Fax: 01830-30821
SWITZERLAND: Keithley Instruments SA • Kriesbachstrasse 4 • 8600 Dübendorf • 01-821-9444 • Fax: 01-820-3081