

Valuetronics International, Inc.  
1-800-552-8258  
MASTER COPY

---

**KEITHLEY**

**Operator's Manual  
Model 181 Digital Nanovoltmeter**

Contains Operating Instructions for  
Model 181

Keithley Instruments, Inc.  
28775 Aurora Road/Cleveland, Ohio 44139/(216) 248-0400

## WARRANTY

We warrant each of our products to be free from defects in material and workmanship. Our obligation under this warranty is to repair or replace any instrument or part thereof which, within a year after shipment, proves defective upon examination. We will pay local domestic surface freight costs.

To exercise this warranty, write or call your local Keithley representative, or contact Keithley headquarters in Cleveland, Ohio. You will be given prompt assistance and shipping instructions.

## REPAIRS AND CALIBRATION

Keithley Instruments maintains a complete repair and calibration service as well as a standards laboratory in Cleveland, Ohio.

A Keithley service facility at our Munich, Germany office is available for our customers throughout Europe. Service in the United Kingdom can be handled at our office in Reading. Additionally, Keithley representatives in most countries maintain service and calibration facilities.

To insure prompt repair or recalibration service, please contact your local field representative or Keithley headquarters directly before returning the instrument. Estimates for repairs, normal recalibrations and calibrations traceable to the National Bureau of Standards are available upon request.

The logo for Keithley Instruments, featuring the word "KEITHLEY" in a bold, sans-serif font. The letters are white and set against a dark, rectangular background.

Keithley Instruments, Inc./28775 Aurora Road/Cleveland, Ohio 44139/(216) 248-0400/Telex: 98-5469  
Keithley Instruments GmbH/Heiglhofstrasse 5/D-8000 Munchen 70/(089) 714-40-65/Telex: 521 21 60  
Keithley Instruments, Ltd./1, Boulton Road/GB-Reading, Berkshire RG2 ONL/(0734) 86 12 87  
Keithley Instruments SARL/44, Rue Anatole France/F-91121 Palaiseau Cedex/01-014-22-06/Telex: (842) 204188

**Operator's Manual  
Model 181  
Digital Nanovoltmeter**

**Contains Operating Instructions for  
Model 181**

**©Copyright 1980 Keithley Instruments, Inc.  
Second Printing, June 1980, Cleveland, Ohio, U.S.A.  
Document No. 30918, Rev. B**

## TABLE OF CONTENTS

SECTION	PAGE
1. GENERAL INFORMATION . . . . .	1-1
1-1. INTRODUCTION. . . . .	1-1
1-4. Accessories . . . . .	1-1
1-5. Warranty Information . . . . .	1-2
1-7. Change Notices. . . . .	1-3
1-9. Specifications. . . . .	1-3
2. OPERATION . . . . .	2-1
2-1. GENERAL . . . . .	2-1
2-3. Unpacking and Inspection. . . . .	2-1
2-5. Preparation for Use . . . . .	2-1
2-7. Line Voltage Selection. . . . .	2-1
2-8. Power Up. . . . .	2-2
2-10. Operating Instructions. . . . .	2-2
2-12. Basic Voltage Measurement . . . . .	2-2
2-13. Microvolt and Nanovolt Measurements . . . . .	2-2
2-14. HI RES. . . . .	2-3
2-16. Zero. . . . .	2-3
2-18. Damping . . . . .	2-3
2-20. Filter. . . . .	2-4
2-22. Rear Panel Connections. . . . .	2-5
2-23. ERROR Messages. . . . .	2-6
2-24. Source Resistance . . . . .	2-7
2-26. Microvolt and Nanovolt Measurement Considerations . . . . .	2-7
3. SYSTEM OPERATION. . . . .	3-1
3-1. ADDRESS SELECTION . . . . .	3-1
3-6. Device Dependent Commands . . . . .	3-2
3-8. Talk-Only Mode. . . . .	3-4
3-9. Programming Example . . . . .	3-6
3-10. Data Format . . . . .	3-6
3-11. SRQ Status Byte Format. . . . .	3-7

## SECTION 1. GENERAL INFORMATION

## 1-1. INTRODUCTION.

1-2. The Keithley Model 181 is a 5-1/2 and 6-1/2 digit DC voltmeter with resolution to 10nV. The Model 181 is a unique DC voltmeter in the respect that it combines microprocessor technology for full programmability with a new concept in nanovolt front ends. It provides highly accurate, stable and low noise readings from 10nVolts to 1000VDC on 7 voltage ranges. The 2V through the 1000V ranges utilize the 5-way binding posts. The 2mV through the 200mV ranges utilize the special low thermal input connector.

1-3. The Model 181 has many features, some of which are listed below:

A. The Model 181 is ultra-sensitive. The resolution of the 2mV range reaches down to  $10^{-8}$  volts (10n volts).

B. 5-1/2 digit resolution to 6-1/2 digit resolution at the touch of a button.

C. IEEE Interface that enables the 181 to be implemented into any measurement system that utilizes the IEEE 488 bus.

D. The Analog Output which exactly reflects the appropriate display reading is easily accessible on the rear panel of the 181.

E. Damping button that changes filter response for optimum measurement speed.

F. Filter button that changes time constant for a quieter measurement.

G. Color coded front panel for easy reference.

1-4. Listed below are the Optional Accessories that can be ordered to extend the measurement capability of the Model 181.

1. The Model 1483 Low-Thermal Connection Kit. The Model 1483 is useful in constructing low-thermal connections in experimental setups. The kit consists of a crimp tool, pure copper lugs, low thermal cadmium solder, copper alligator clips and assorted hardware.

2. Model 1484 Refill Kit. The Model 1484 contains replacement parts for the Model 1483 Low-Thermal Connection Kit.

3. Model 1485 Female Low-Thermal Input Connector. The Model 1485 is the input connector for the millivolt ranges.

4. Model 1486 Male Low-Thermal Connector. The Model 1486 is a mating connector for Model 1485. It can be used to construct a custom length cable to connect to the particular measurement setup used. This connector is used on the Models 1506 and 1507.

5. Model 1488 Low-Thermal Shorting Plug. The Model 1488 is a Low-Thermal Shorting Plug for checking instrument offset and drift.

6. Model 1503 Low-Thermal Solder. The Model 1503 is Low-Thermal Cadmium Solder. It can be used to solder connections for sensitive low voltage measurements.

7. Model 1506 Low-Thermal Input Cable. The Model 1506 is supplied with the Model 181. It is specially designed to provide excellent shielding for sensitive measurements. The Model 1506 is a triaxial cable four feet long with a Model 1486 at one end and two copper alligator clips terminating the other end.

8. Model 1507 Low-Thermal Input Cable. The Model 1507 is a triaxial cable four feet long with a Model 1486 at one end and two copper spade lugs terminating the other end. It is specially designed to provide excellent shielding for sensitive measurements.

9. Model 1815 Maintenance Kit. The Model 1815 is a Model 181 Maintenance Kit that consists of a Calibration Cover and Extender Cables. The Calibration Cover is necessary when calibrating the 181 in order to locate the adjustments quickly and easily. It also permits the inside temperature of the 181 to remain stable during calibration. The Extender Cables permit easy access to the individual PC cards contained in the Model 181.

#### 1-5. Warranty Information.

1-6. The warranty is given on the inside front cover of this manual. If there is a need to exercise the warranty, contact the Keithley representative in your area to determine the proper action to be taken. Keithley maintains service facilities in the United Kingdom and West Germany, as well as in the United States. Check the inside front cover of this manual for addresses.

A service manual will be available before the warranty expires. To obtain the Service Manual write to the following address:

Keithley Instruments  
Technical Manuals Department  
28775 Aurora Road  
Cleveland, OH 44139

1-7. Change Notices.

1-8. Improvements or changes to the instrument which occur after printing of this manual will be explained on a change notice sheet attached to the inside back cover.

IMPORTANT

The  can be found in various places in the manual. Carefully read the associated caution statements with regard to proper use and handling of the instrument. Damage to the instrument may occur if these precautions are ignored.

This  symbol can be found in various places in the manual. This symbol indicates those areas on the instrument which are potential shock hazards. Carefully read the associated warning statements with regard to proper use and handling of the instrument. Serious personal injury may result if these precautions are ignored.

1-9. The Model 181 detailed specifications are located on page 1-5.

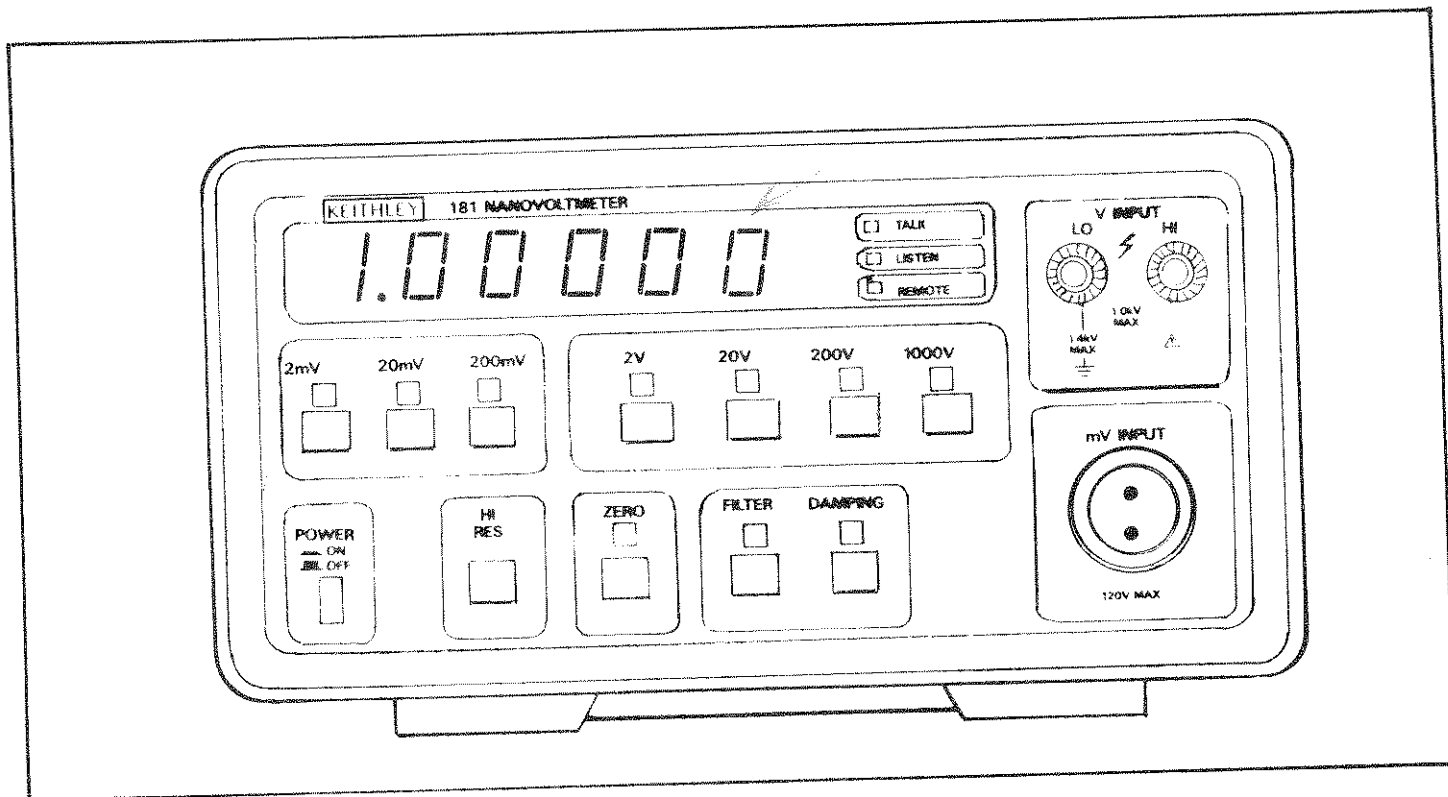

FIGURE 1-1. Front Panel

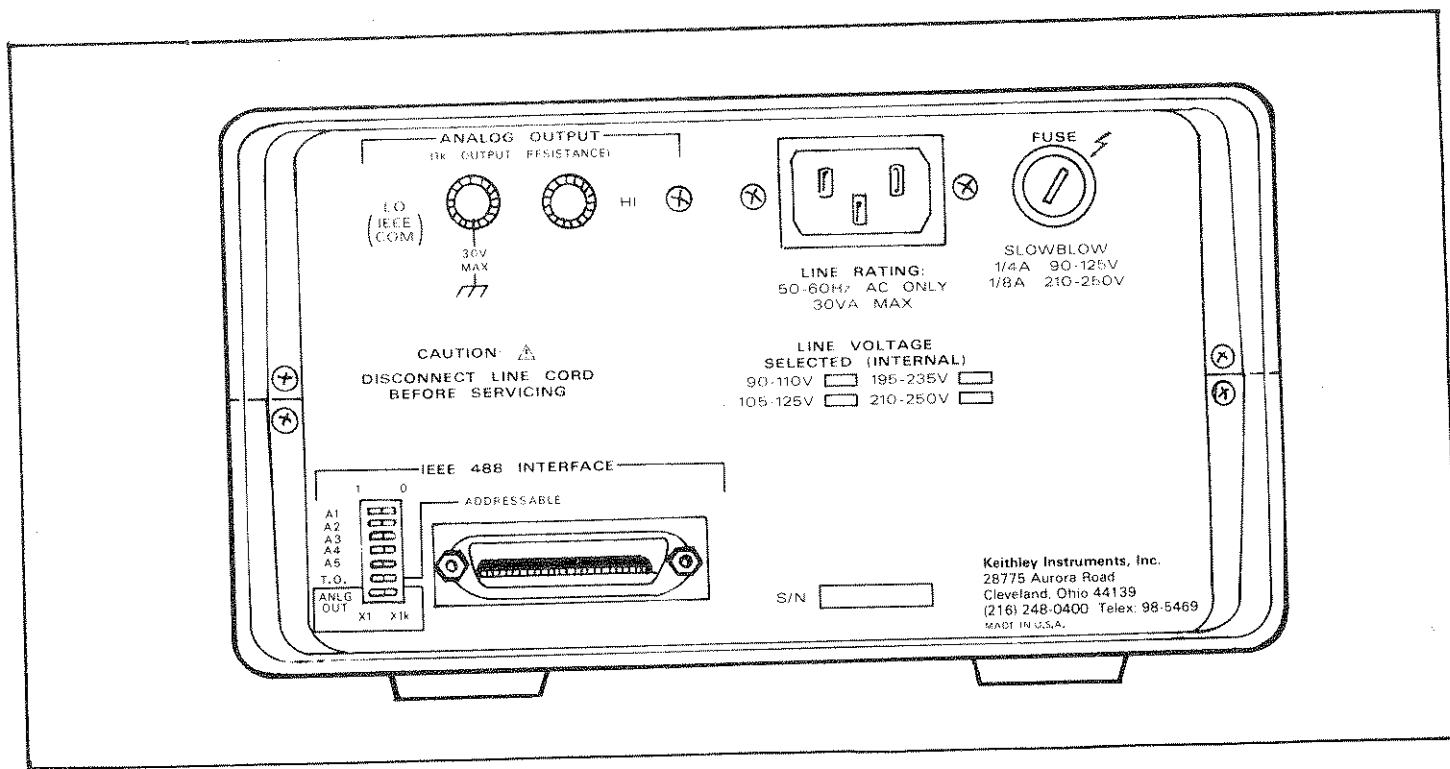

FIGURE 1-2. Rear Panel



## DC VOLTS

Range	5½-digit Resolution	Accuracy ±(%rdg + digits)		Temperature Coefficient ±(%rdg + digits)/°C 0-18°C & 28-35°C	Input Resistance	Maximum Allowable Input	NMRR (Line Frequency)
		24 Hr. 22-24°C	1 Yr. 18-28°C				
2mV	10 nV	.006% + 5d*	.015% + 5d*	.002% + 3d	> 1GΩ	120V**	> 90dB
20mV	100 nV	.006% + 2d*	.015% + 2d*	.002% + .5d	> 1GΩ	120V**	> 80dB
200mV	1 μV	.006% + 2d	.015% + 2d	.002% + .2d	> 1GΩ	120V**	> 80dB
2 V	10 μV	.004% + 1.5d	.007% + 2d	.0007% + .2d	> 1GΩ	1000V	> 60dB
20 V	100 μV	.004% + 1.5d	.01% + 2d	.0008% + .2d	10MΩ	1000V	> 60dB
200 V	1mV	.004% + 1.5d	.01% + 2d	.0008% + .2d	10MΩ	1000V	> 60dB
1000 V	10mV	.005% + 1.5d	.01% + 2d	.0012% + .2d	10MΩ	1000V	> 60dB

\*When properly zeroed.

\*\*10 seconds maximum; 35V rms continuous.

CMRR: 160dB on mV ranges, 140dB on V ranges; at DC and line frequency (50 or 60Hz).

## IEEE-488 BUS IMPLEMENTATION:

Multiline Commands: DCL, LLO, SDC, GET.

Uniline Commands: IFC, REN, EOJ, SRQ, ATN.

## PROGRAMMABLE PARAMETERS:

Front Panel Controls: Range, Filter, Zero, Damping, Hi Resolution.

Internal Parameters: SRQ Response, Trigger Modes, Data Terminators.

ADDRESS MODES: Talk-Only and Addressable.

## TRIGGER MODES:

One Shot: Updates output buffer once at first valid conversion after trigger on TALK and/or GET.

Continuous: Updates output buffer at all valid conversions after trigger.

## GENERAL

NOISE: Less than 30nV p-p on lowest range with Filter on.

INPUT CAPACITANCE: 5000pF on mV ranges.

SETTLING TIME: 0.5 sec. to within 25 digits of final reading with Filter on, Damping off.

FILTER: 3-pole digital; RC = .5, 1 or 2 seconds depending on range.

CONVERSION SPEED: 4 readings/second.

DISPLAY: Seven 13mm (0.5 in.) LED digits with appropriate decimal point and polarity.

OVERLOAD INDICATION: Display indicates polarity and OFLO.

## ANALOG OUTPUT:

Accuracy: ±(.15% of displayed reading + 1mV).

Time Constant: 400ms.

Level: ±2V full scale on all ranges; X1 or X1000 gain.

ISOLATION: Input LO to Output LO or power line ground: 1400V peak,  $5 \times 10^5 \text{V} \cdot \text{Hz}$ , greater than  $10^9 \Omega$  paralleled by 100pF.

WARMUP: 1 hour to rated accuracy when properly zeroed.

## ENVIRONMENTAL LIMITS:

Operating: 0°C to 35°C, 0% to 80% relative humidity.

Storage: -25°C to 65°C.

POWER: 105-125V or 210-250V (internal switch selected), 50-60Hz, 30V•A max.

INPUT CONNECTORS: Special low thermal for 200mV and lower ranges. Binding posts for 2V to 1000V ranges.

DIMENSIONS, WEIGHT: 127mm high × 216mm wide × 359mm deep (5" × 8½" × 14½"). Net weight 3.85kg (8½ lbs.).

ACCESSORY SUPPLIED: Model 1506 Low Thermal Input Cable.

## ACCESSORIES AVAILABLE:

Model 1483 Low Thermal Connection Kit

Model 1484 Refill Kit for 1483 Kit

Model 1485 Female Low Thermal Input Connector

Model 1486 Male Low Thermal Input Connector

Model 1488 Low Thermal Shorting Plug

Model 1503 Low Thermal Solder and Flux

Model 1506 Low Thermal Input Cable (4 ft., Clips)

Model 1507 Low Thermal Input Cable (4 ft., Lugs)

Model 1815 Maintenance Kit



## SECTION 2. OPERATION

## 2-1. GENERAL.

2-2. This section provides information needed for incoming inspection, preparation for use, and operation for the Model 181.

## 2-3. Unpacking and Inspection.

2-4. The Model 181 was carefully inspected both mechanically and electrically before shipment. Upon receiving the Model 181, unpack all items from the shipping container and check for any obvious damage that may have occurred during transit. Report any damage to the shipping agent. Retain and use the original packaging materials if reshipment is required. The following items are shipped with all Model 181 orders:

- A. Model 181 Nanovoltmeter.
- B. A copy of this manual.
- C. Model 1506 Low-Thermal Input Cable.
- D. Separate optional accessories, as ordered.

## 2-5. Preparation for Use.

2-6. Preparation of the Model 181 for use consists of selecting the appropriate line voltage and turning the Model 181 on.

## 2-7. Line Voltage Selection.

Select the proper setting on S102 to accommodate the appropriate line voltage along with the proper fuse. Refer to Table 2-1.

TABLE 2-1  
Line Voltage Selection

Input Voltage	Fuse Type	FUSE Keithley P/N
115VAC	3AG, SLO BLO 250V, 1/4A	FU-17
230VAC	3AG, SLO BLO 250V, 1/8A	FU-20

## OPERATION

The line frequency is selected automatically by the Model 181.

**2-8. Power Up.**

2-9. Upon power up the Model 181 displays the line frequency with the current software revision level. (e.g. F60 b2) for approximately one second. Also, upon power up the Model 181 goes to the 1000V range. This is one part of the default conditions that are explained in detail in Section 3-7.

**2-10. Operating Instructions.**

2-11. The basic operating instructions for the Model 181 are discussed in the following paragraphs. The Front Panel controls are very straight forward and easy to use. The Rear Panel connectors and switches are clearly marked for easy reference.

On the Front Panel there two are input connectors. The two 5-way binding posts are utilized for the 2V thru the 1000V ranges. The special Low-Thermal Input Connector just below the two 5-way binding posts is utilized for the 2 millivolt thru the 200 millivolt ranges only. The special Low-Thermal Input Connector is used for the more sensitive ranges because it minimizes thermal emfs.

**2-12. Basic Voltage Measurement.**

The basic voltage measurement is made on the 2V thru the 1000V ranges. Make the measurement as follows:

- A. Turn on the Model 181 by depressing the on/off switch located the Front Panel. Allow one hour warm-up time for rated accuracy.
- B. Select desired range by pressing the appropriate Front Panel range button.
- C. Select appropriate functions such as Filter, Damping, Zero, or HI RES as needed. Refer to Section 2-14 for information about the above functions.
- D. Connect the DC Voltage signal that is to be measured to the two 5-way binding posts located on the Front Panel.
- E. Make the measurement by reading the Front Panel display.

**2-13. Microvolt and Nanovolt Measurements.**

- A. Turn on the Model 181 by depressing the on/off switch located on the Front Panel. Allow one hour warm up time for rated accuracy; four hours for optimum drift performance.

B. Select the desired range by pressing the appropriate Front Panel button.

C. Select appropriate function as needed, such as Filter, Damping, Zero or HI RES. Refer to Section 2-14 for information concerning the above functions.

D. Connect the DC voltage signal that is to be measured to the Low-Thermal Input Connector on the Front Panel. Observe the section on Microvolt and Nanovolt Measurement Considerations. While connecting up the signal to be measured, be sure to utilize the Model 1506 low thermal input cable.

E. Make the measurement by reading the Front Panel display.

#### 2-14. HI RES

2-15. The display can be expanded from 5-1/2 digit to 6-1/2 digit resolution by pressing the HI RES button. This is an advantage when a measurement does not provide enough resolution in the 5-1/2 digit mode. When in the 6-1/2 digit mode of display pressing the HI RES button will return the Model 181 to the 5-1/2 digit mode of display.

#### 2-16. Zero

2-17. The Zero control serves as a baseline suppression. When the Zero control is enabled, the Zero LED will light. All readings displayed while in the Zero mode are the difference between the stored baseline and the actual voltage level. The zero control can be disabled by pressing the zero button.

The baseline obtained while the zero control is enabled is valid for all mV ranges. Therefore, a mV range change will not affect the zero baseline obtained previously. The same is true for the Volts ranges. Changing from mVolts to Volts will invalidate the zero baseline and vice versa.

#### 2-18. Damping.

2-19. With Damping off, a large input change is sensed and the microprocessor disables the digital filter to permit a fast reading update. When the reading is within 25 digits of the final value for the 2mV range and within 6 digits for all other ranges, the microprocessor then enables the filter for a low noise settling to the final value. With Damping on, the digital filter is continuously enabled. This situation is preferred when measuring a slowly varying voltage signal. When Damping is on, the Damping LED is lit.

## 2-20. Filter.

2-21. The 3-pole digital filter is switched on and off as a function of rate of change of the input signal. Pressing the Filter button increases the RC time constant which provides a quieter measurement. The Filter can be defeated on the IEEE bus for 150nV p-p noise (raw data) and settling time of 0.5 seconds. Judicious use of "Damping" and "Filter" allows the user to tailor the 181 response to optimize speed/noise tradeoffs. Refer to Figure 2-1.

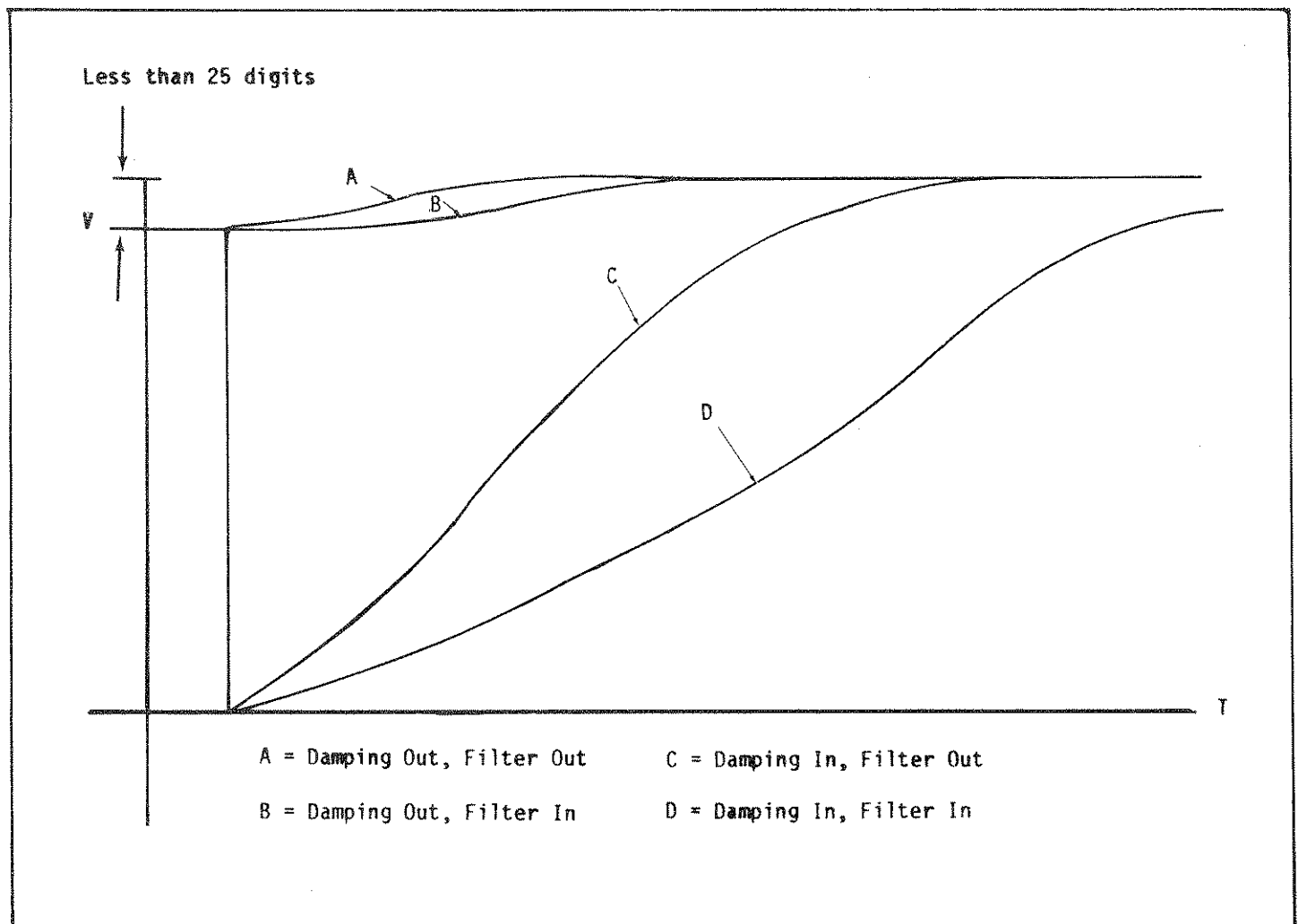

FIGURE 2-1. Filter, Damping, Response Graph

TABLE 2-2  
Settling Times

(The readings all settle to within 0.002% of the Full Scale in the specified time.)

Range	Filter Off Damping Off	Filter Off Damping On	Filter On Damping Off	Filter On Damping On
2mV:	4S	16S	8S	32S
20mV:	1S	8S	4S	16S
200mV:	.5S	8S	4S	16S
2V-1000V:	.5S	4S	2S	8S

## 2-22. Rear Panel Connections.

The Rear Panel connections are clearly shown in Figure 1-2.

The Analog Output is provided via two 5-way binding postson the rear panel. The Analog Output exactly reflects the appropriate display reading. It is also isolated from the Front Panel input LO with optical isolators in order to eliminate ground loop problems. There are two gain settings (X1, X1000) for the analog output. They are on the same bank of switches as the primary address switches (Figure 3-1). These gain settings permit the user to select the upper  $\pm 2,000$  counts or the lower  $\pm 2,000$  counts of the display reading. The full span of the 6-1/2 digit display can be covered by a chart recorder. When the display reads OFLO, the analog output will read +2 volts or -2 volts depending on the polarity of the source. The analog output can be zeroed by the Front Panel zero.

The Line Power Cord connection is made on the rear panel via a recessed male power cord connector (J1011).

TABLE 2-3  
Analog Output

Range	2V FULL SCALE		2V FULL SCALE	
	X1	Output Resistance	X1000	Output Resistance
2mV	2mV	1K $\Omega$	2 $\mu$ V	1K $\Omega$
20mV	20mV	1K $\Omega$	20 $\mu$ V	1K $\Omega$
200mV	200mV	1K $\Omega$	200 $\mu$ V	1K $\Omega$
2V	2V	1K $\Omega$	2mV	1K $\Omega$
20V	20V	1K $\Omega$	20mV	1K $\Omega$
200V	200V	1K $\Omega$	200mV	1K $\Omega$
1KV	1KV*	1K $\Omega$	2V	1K $\Omega$

\* = 1V Full Scale

The Line Fuse is also accessible on the rear panel. Refer to Table 2-1 for information about selecting the proper fuse.

The IEEE 488 Interface Standard connector is located on the rear panel along with the primary address switches. Refer to Section 3-2 for more information on the primary address switches. Refer to Section 3 for IEEE 488 Interface information.

### 2-23. ERROR Messages.

When a programming error is seen by the Model 181, it shows up on the Status Byte when SRQ is enabled. Refer to Section 3-11.

The Front Panel Error Message consists of "OFLO" with polarity sign when a voltage range is overranged (e.g. 200K counts or more for 5-1/2, 2000K counts or more for 6-1/2).



## 2-24. Source Resistance.

2-25. The Model 181 can be used in measurement circuits with up to  $10M\Omega$  source resistance. At higher source resistance proper shielding is necessary.

## 2-26. Microvolt and Nanovolt Measurement Considerations.

2-27. Making DC volts measurement at this ultra-low level requires special considerations for noise, thermal emfs and various other parameters. Measurement notes and considerations are given in the following paragraphs to permit the user to be informed about these parameters before making the measurements.

2-28. Noise considerations. The limit of resolution in voltage and current measurements is determined largely by the noise generated in the source. Stray low-level noise is present in some form in nearly all electrical circuits. The instrument does not distinguish between stray and signal voltages since it measures the net voltage. When using the 2mV, 20mV, or 200mV ranges, consider the presence of low-level electrical phenomena such as thermocouples (thermoelectric effect), flexing of coaxial cables (triboelectric effect), apparent residual charges on capacitors (dielectric absorption), and battery action of two terminals (galvanic action).

2-29. Johnson Noise. The ultimate limit of resolution in an electrical measurement is set by thermal agitation or Johnson noise generated in the circuit resistance. This noise voltage is proportional to the square root of the product of the absolute temperature, the bandwidth, and the resistance.

Johnson Noise Equations. The noise voltage developed by a metallic resistance is:

$$E_{rms} = \sqrt{4KTRF}$$

Diagram illustrating the components of the Johnson noise equation  $E_{rms} = \sqrt{4KTRF}$ :

- Noise Bandwidth
- Source Resistance
- Temperature °K
- Boltzman's Constant

At room temperature:

$$E_{rms} = 1.29 \times 10^{-10} \sqrt{RF}$$

$$E_{p-p} = 6.5 \times 10^{-10} \sqrt{RF}$$

The amount of noise in a given circuit can be decreased by reducing the bandwidth, by reducing the circuit resistance or by cooling the circuit. Reducing the bandwidth is the means most often used. However, this requires that a longer measuring time be allowed for a given accuracy. Reducing the resistance is not generally useful since the signal developed is reduced even more than the noise. For example, if the resistance of a shunt used to measure current is reduced by a factor of 100, the noise is reduced by a factor of 10, while the voltage drop across the shunt is reduced by a factor of 100. Cooling is sometimes the only available method for reducing the noise. A change from room temperature (293°K) to liquid nitrogen (77°K) will reduce the noise by a factor of approximately two.

2-30. Thermal EMFs. Thermal emfs (thermoelectric potentials) are generated by thermal differences between two junctions of dissimilar metals. To minimize the drift caused by thermal emfs, use copper leads to connect the circuit to the instrument. The Keithley accessory Model 1483 Low Thermal Connection Kit contains all necessary materials for making very low thermal copper crimp connections for minimizing thermal effects. Circuit performance can also be improved by reducing temperature gradients within the circuit. This can be done by placing the remaining junctions near one another, and by providing good thermal contact with a common heat sink. Most good electrical insulators are good thermal insulators as well, that is, they have very low thermal conductivity. Certain materials are available that combine good electrical insulation with high thermal conductivity, such as hard anodized aluminum, beryllium oxide, specially filled epoxy resins, sapphire and diamond. By using these materials together with a massive metallic heat sink the temperature gradients across the remaining junctions will be minimized, as will the thermal emfs generated.

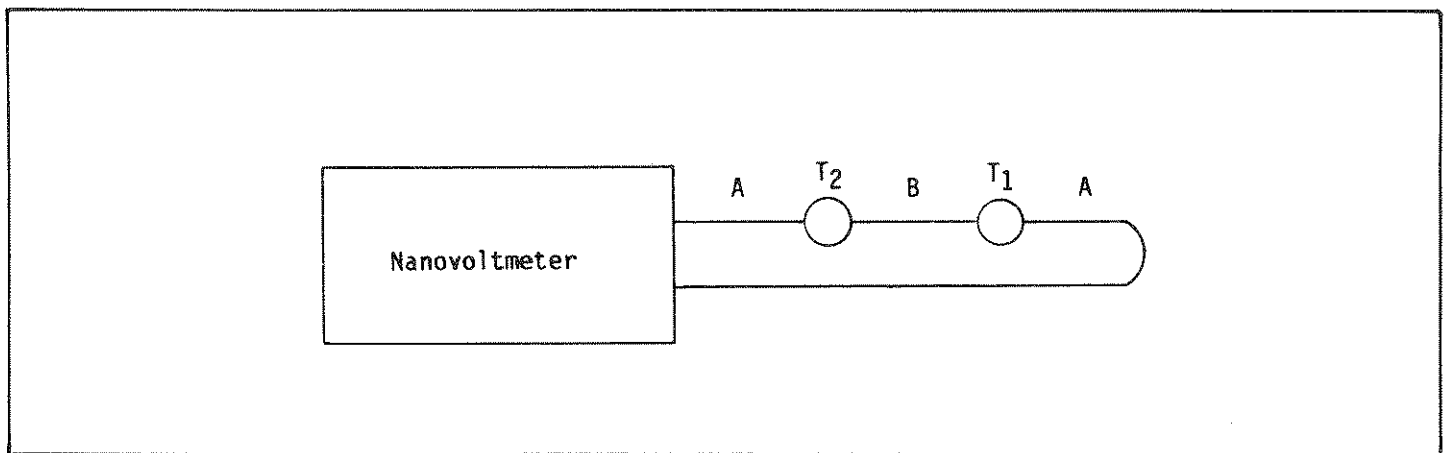
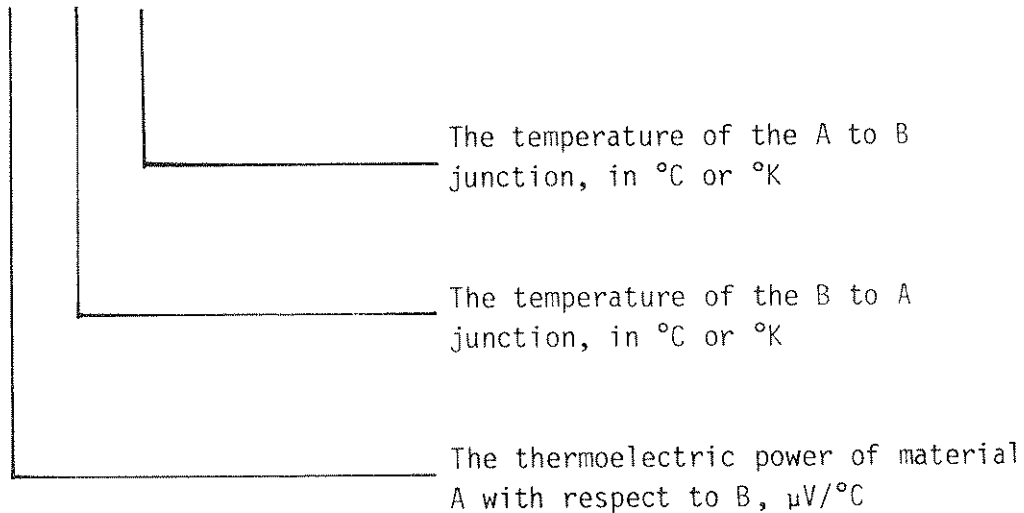

FIGURE 2-2. Thermal EMF Equations

The thermal EMF developed by dissimilar metals A and B in a series circuit is:

$$E_{AB} = Q_{AB}(T_1 - T_2)$$



2-31. Magnetic Fields. The motion of a conductor in a magnetic field, even one as weak as the earth's, can cause significant spurious signals in nanovolt measurements. The principal means for reducing this source of error is to reduce the area enclosed by the circuit. Minimizing motion of the various parts of the circuit will also help. It may be necessary to provide some form of magnetic shielding. The most useful materials for this are special alloys with a high permeability at low flux densities, such as mu metal.

Troublesome magnetic fields may be generated within the circuit by conductors carrying large currents. By using twisted pairs of wires to carry large currents, the magnetic field generated may be largely cancelled out.

2-32. Ground Loops. Frequently, a complete measuring system will have several points connected to earth ground. The power source, the experiment itself and the indicating instrument may all be grounded. If a small difference in potential exists between these points, a large ground current may circulate, causing unexpected voltage drops to occur. In making low level DC voltage measurements, it is desirable to have a single ground at one point. If the power source, the indicating instrument and other parts of the circuit are well isolated from earth ground, the most appropriate single point may be chosen with ease. Do not connect mV low and Volts low simultaneously. This will create a ground loop.

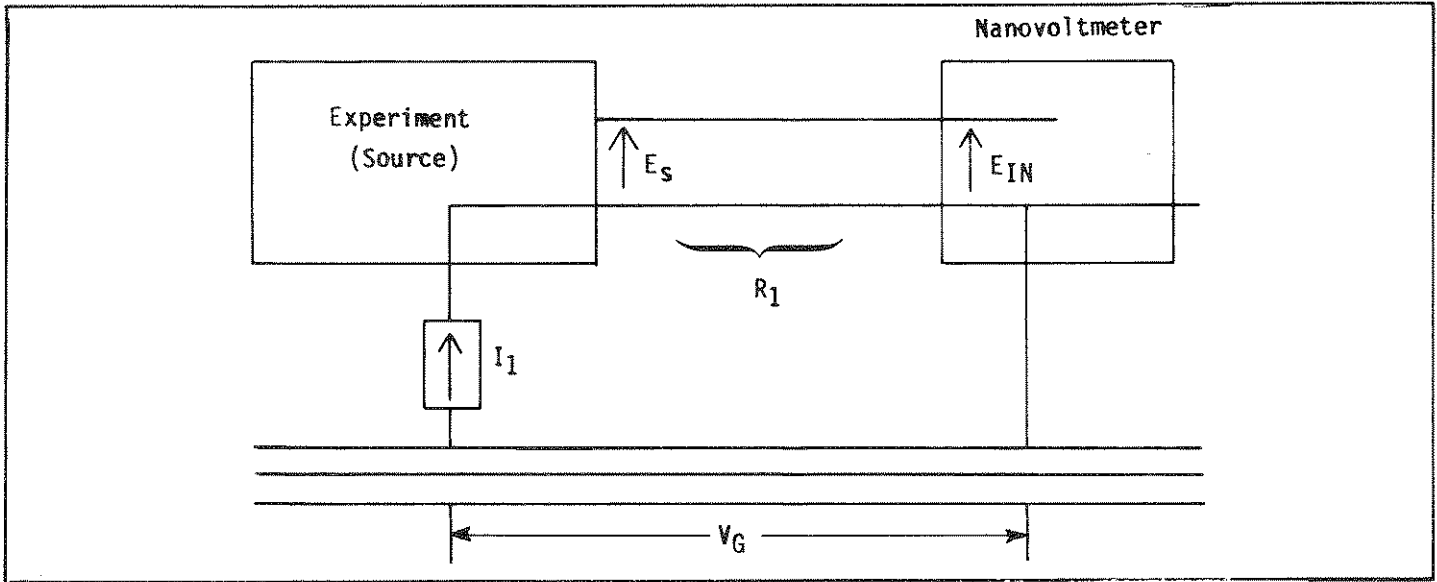
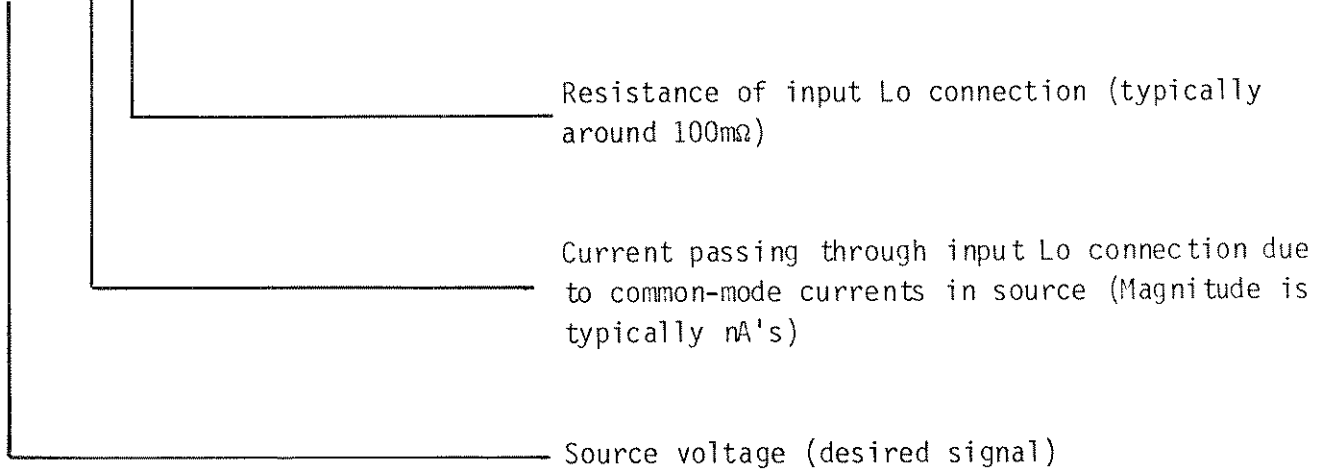

FIGURE 2-3. Single Ground Configuration

Input voltage to the nanovoltmeter is:

$$E_{IN} = E_s + I_1 R_1$$



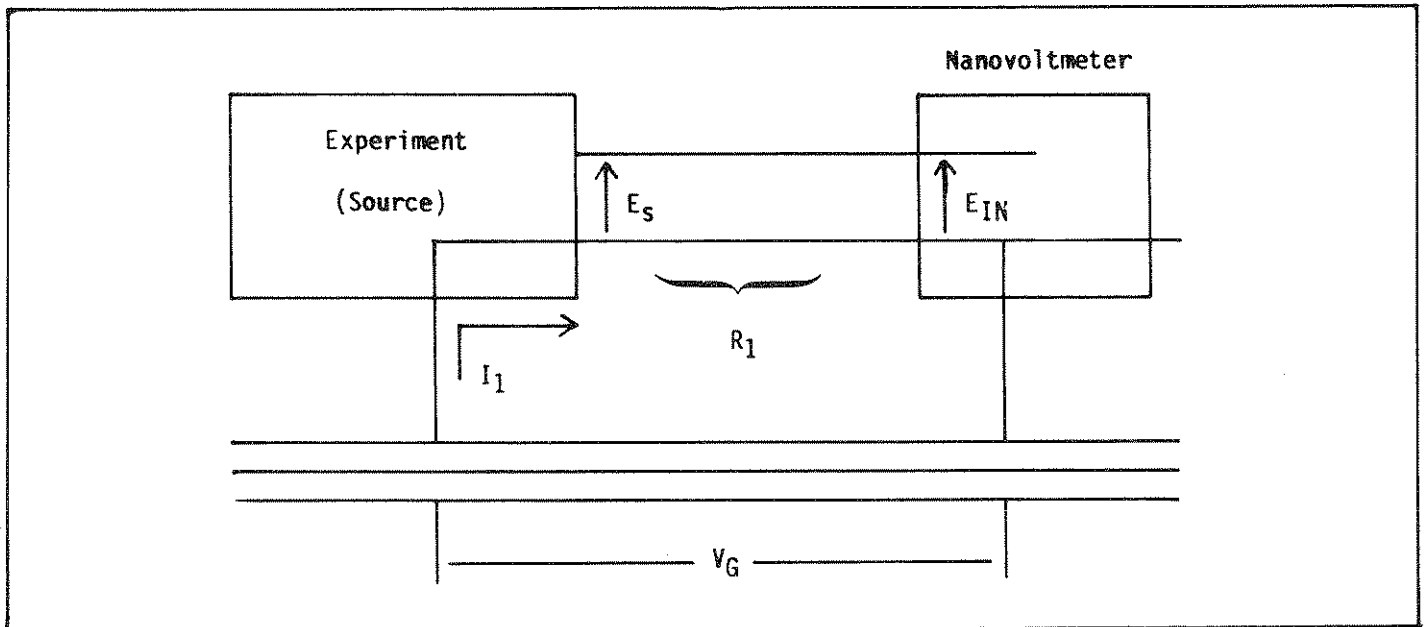
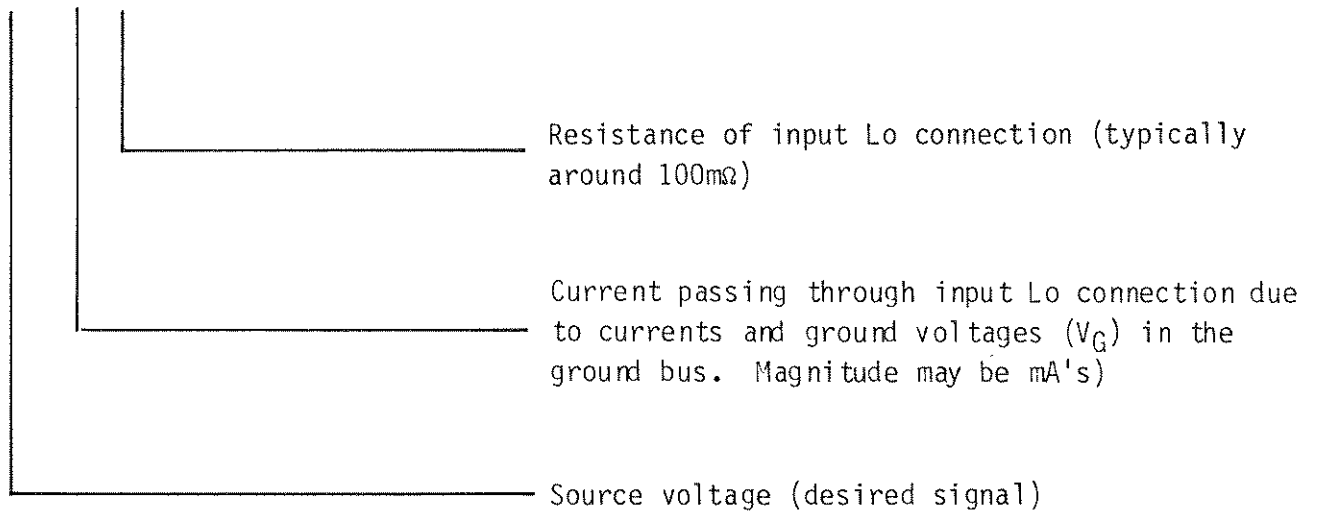

FIGURE 2-4. Multiple Grounding Configuration

Input voltage to the nanovoltmeter is:

$$E_{IN} = E_S + I_1 R_1$$



$I_1 R_1$  may exceed  $E_S$  by orders of magnitude.



## SECTION 3. SYSTEM OPERATION

## 3-1. ADDRESS SELECTION.

## 3-2. Primary Address.

The primary address of the Model 181 is selected via 5 switches which are located on the rear panel. The 5 switches permit the selection of 31 primary talker/listener address pairs. Binary 11111 is reserved for the Untalk and Unlisten commands. The Primary Address Switches are set to 5(00101) at the factory. To address the Model 181, the IEEE 488 controller must send the primary address of the Model 181. The Primary Address is updated only upon power up.

## 3-3. Bus Management Lines.

- A. IFC, Interface Clear: Clear Interface. No state changes in the 181.
- B. REN, Remote Enable: Go to Remote Control. Remote LED will light when in Remote.
- C. EOI, End: Asserted during last byte of multi-byte data transfer.
- D. SRQ, Service Request: Request serial poll service.
- E. ATN, Attention: Asserted when address is present on the bus.

## 3-4. Bus Commands Implemented.

- A. Universal Commands.
  - 1. DCL, Device Clear: Go to default conditions (see Section 3-7).
  - 2. LLO, Local Lock Out: If LLO is given, the front panel controls cannot cause a change in status in the 181.
  - 3. SPD, Serial Poll Disable: Disable serial polling.
  - 4. SPE, Serial Poll Enable: When addressed to talk, the 181 will send an SRQ Status byte.
  - 5. UNT, Untalk: Put 181 into an idle state, if it was previously in talk.
  - 6. UNL, Unlisten: Put 181 into an idle state, if it was previously in listen.

## B. Addressed Commands.

1. SDC, Selected Device Clear: If addressed to listen, same as device clear (DCL).
2. GET, Group Execute Trigger: If addressed to listen, it will automatically trigger a conversion.
3. GTL, Go to Local: If addressed to listen, the 181 will go to front panel control. Do not change current machine status.

## 3-5. Input Control.

The status words define the range and mode of operation by which the data will be taken. The status words can be modified by the following device dependent commands sent via the bus.

## 3-6. Device Dependent Commands.

Any or all of the following device dependent commands may be used followed by an execute command (X) to initiate the change.

Only after the execute command will the programmed change take place.

A. Range Commands: Range Commands which are R1 thru R7 are shown below in Table 3-1, along with various reading rates that are available only across the Bus.

TABLE 3-1  
Reading Rates

Range	DC Volts	Reading Rates
R1	.002	4rdg/sec
R2	.02	4rdg/sec
R3	.2	4rdg/sec
R4	2	8rdg/sec
R5	20	8rdg/sec
R6	20	8rdg/sec
R7	1000	8rdg/sec



### B. Bus Response Mode.

M0, Standard: On error or data, the 181 will not access SRQ. (The status byte will still contain up-to-date information if a serial poll is done).

M1, Interrupt: On error or data, the 181 will access SRQ when appropriate.

### C. Trigger Mode.

T0, Continuous on Talk: The 181 will continuously update the output data buffer after being addressed to talk.

T1, One-Shot on Talk: The 181 will update the output data buffer once each time a conversion is initiated by being addressed to Talk.

T2, Continuous on GET: The 181 will continuously update the output data buffer after a GET command is received.

T3, One-Shot on GET: The 181 will update the output data buffer once each time a conversion is initiated by a GET command.

### D. Programmable Terminator.

The 181 utilizes the ASCII code for terminating data transfer. The power up default is (CR)(LF). ASCII (DEL) indicates no terminator. ASCII (LF) indicates (CR)(LF), and ASCII (CR) indicates (LF)(CR) when sent over the bus.

However, a different terminator can be programmed into the 181 if so desired. For example, to use A as a terminator, program Y(A) to be sent over the bus. Reserved letters are not usable as terminators and they are B,D,M,P,R,T,X,Y and Z.

Y(LF) is the (CR)(LF) terminator when sent over the bus.

### E. Filter.

P0, Filtering is disabled (unavailable on the front panel).

P1, Filter 1 is enabled (Filter is disabled on the front panel).

P2, Filter 2 is enabled (Filter is enabled on the front panel).

## F. Damping.

D0, No Damping

D1, Damping

## G. Zero.

Z0, Zero Out, contents of Zero Buffer equal zero.

Z1, Zero In, when zero is initiated for the next reading (range weighted), it is stored in the Zero buffer. Then it is subtracted from every subsequent reading.

## H. Resolution.

B0, 5-1/2 digit resolution (rounded off from 6-1/2. This is on the display only. The bus is always 6-1/2 digit data).

B1, 6-1/2 digit resolution.

## 3-7. Default Conditions.

A. On SDC or DCL, the 181 will go to the following default conditions:

R7	1000V range
M0	Non SRQ
T0	Continuous On Talk
Y(LF)	Terminator is (CR)(LF)
P1	Filter out on Front Panel
D0	No Damping
Z0	Contents of Zero Buffer equal zero
B0	5-1/2 Digit Resolution

B. Upon power up, the 181 will default to the above conditions.

## 3-8. Talk-Only Mode.

The Model 181 can be used with a printer or other non-intelligent device via the IEEE Bus in the Talk-Only mode. This mode is selected by SW6 on the rear panel. Refer to Figure 1-2 (Rear Panel) and Figure 3-1 (Primary Address Switches).

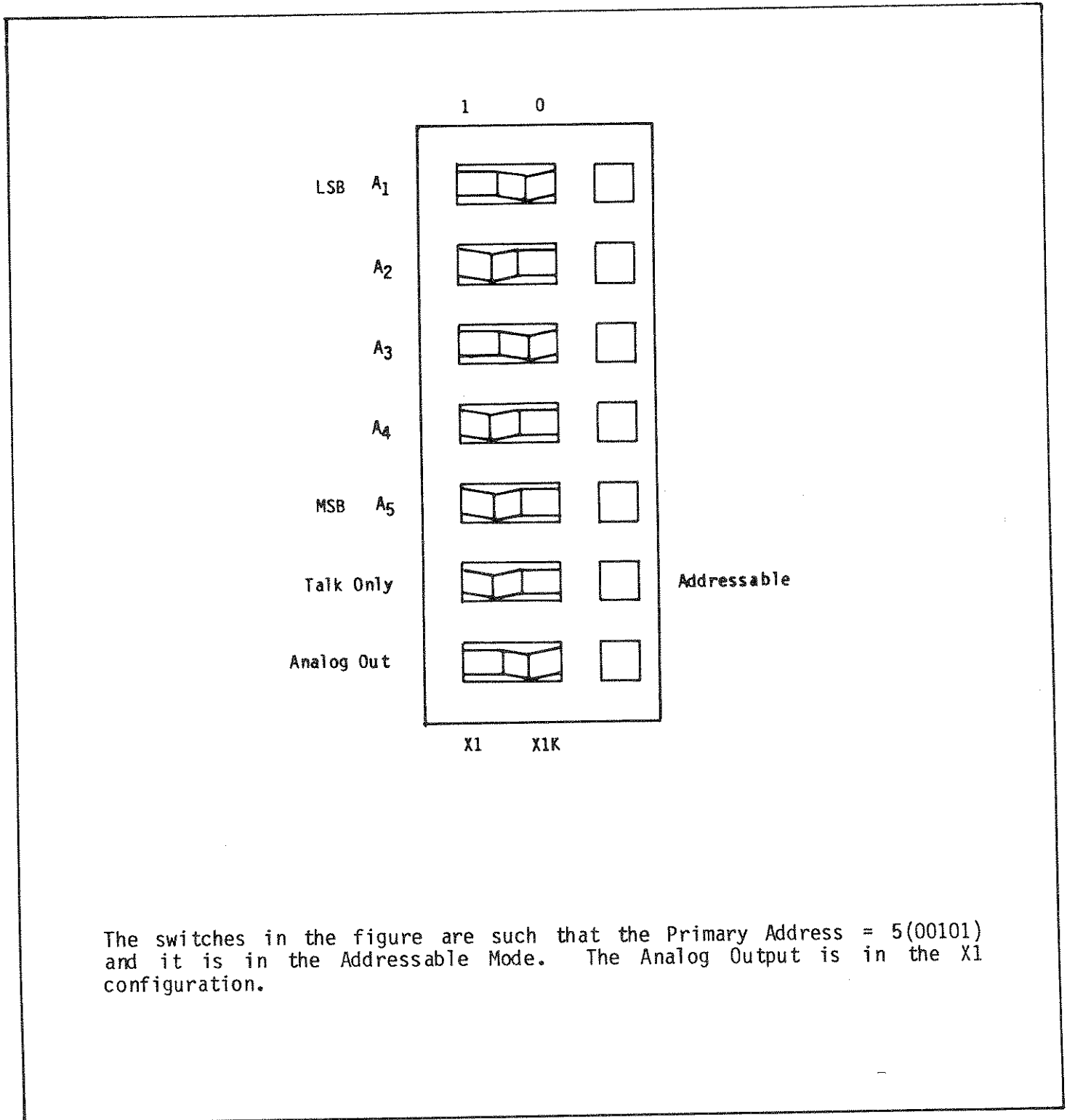

The switches in the figure are such that the Primary Address = 5(00101) and it is in the Addressable Mode. The Analog Output is in the X1 configuration.

FIGURE 3-1. Primary Address Switches

3-9. Shown below is a Programming Example (Using H.P. 9820 desktop computer machine code):

181 Primary Address = 5 (00101)

?	Unlisten
A	Talk Address of Controller
5	Primary Address of 181
T	
Ø	Continuous on Talk
M	
Ø	Non SRQ
R	
4	2 Volt Range
P	
Ø	Filter Out
X	Execute (This character terminates the command string and causes their execution).

The sequence of commands given after Primary Address and prior to execute is unimportant. If an invalid command is given, no change in status will occur.

When in M1 response mode, service will be requested, and the error or data will be indicated in the SRQ status byte.

### 3-10. Data Format.

When addressed to Talk and a byte output request is given, the 181 will transmit the current contents of its output data buffer as a 16-18 byte ASCII string. Actual length is dependent upon the number of programmed terminators.

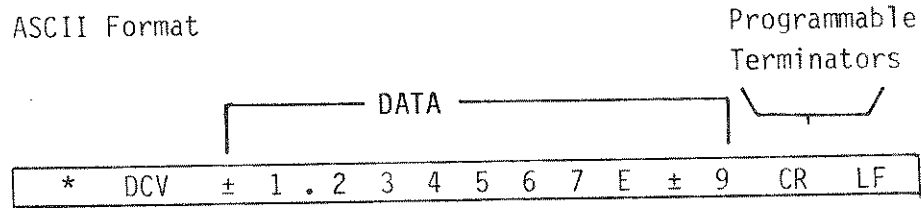

\*N = Normal Reading  
 O = Overflow Reading  
 Z = Zeroed Reading

3-11. SRQ Status Byte Format.

The SRQ status byte is asserted only in the M1 Bus Response Mode. It indicates that either data or an error is present. To read the status byte give a serial poll enable (SPE).

A. Status Byte.

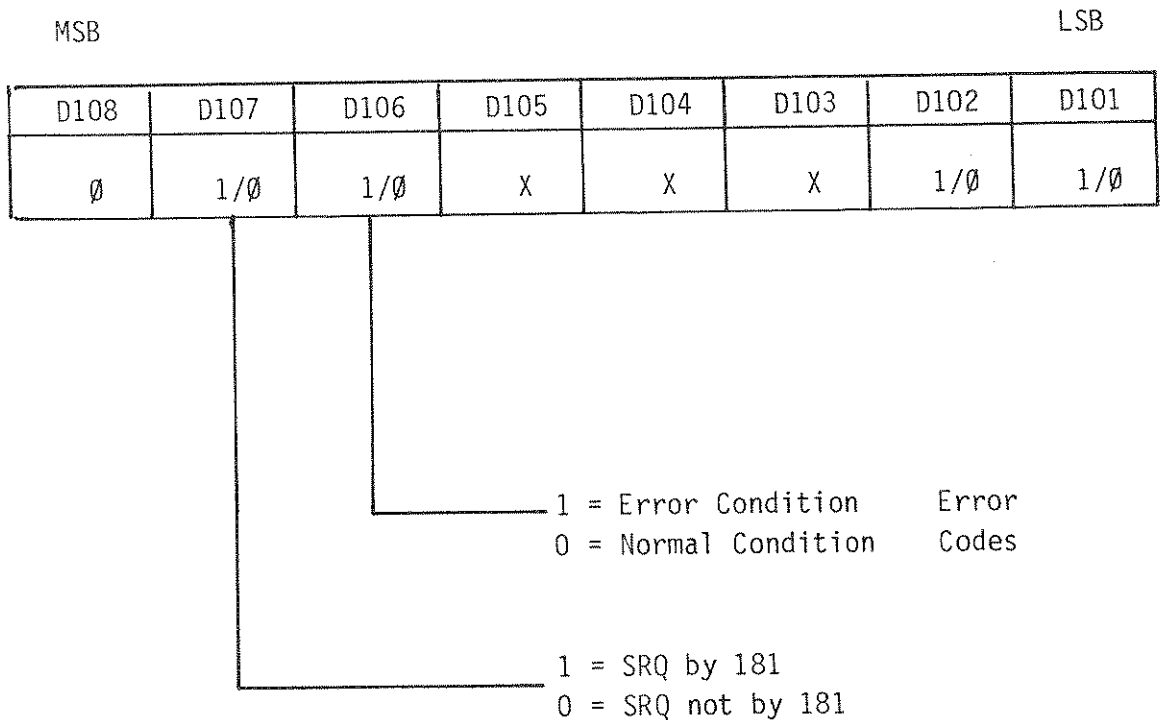

FIGURE 3-2. Status Byte Format

## B. Error Codes (D106=1)

Hex Code

00	Illegal Device Dependent Command (e.g., H)
01	Illegal Device Dependent Command Option (e.g., R9)
10	Illegal Command String Length (Greater than 17 characters)

## C. Data Codes (D106=0)

\*HEX Code

0	Normal
1	Overflow

\*D102 thru D101

TIMING DIAGRAMS

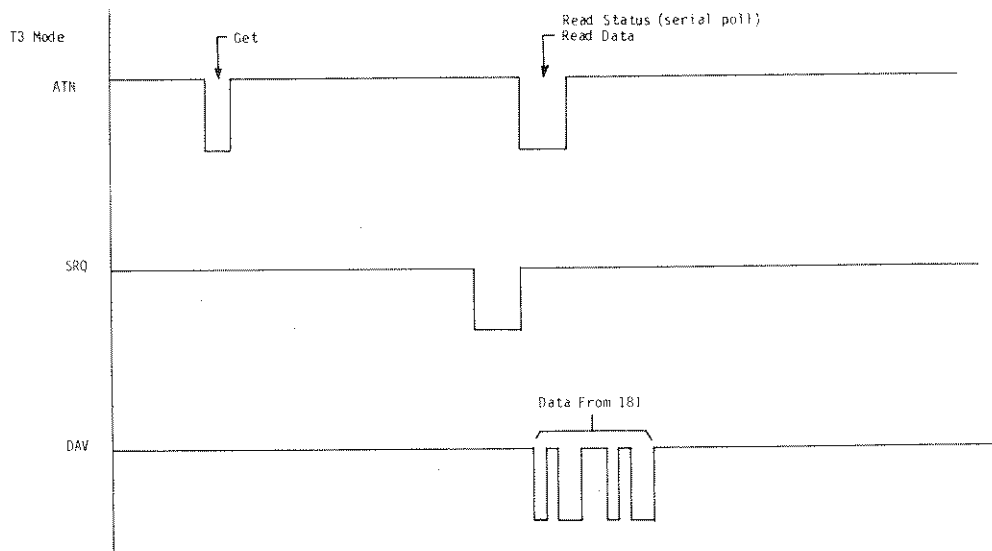
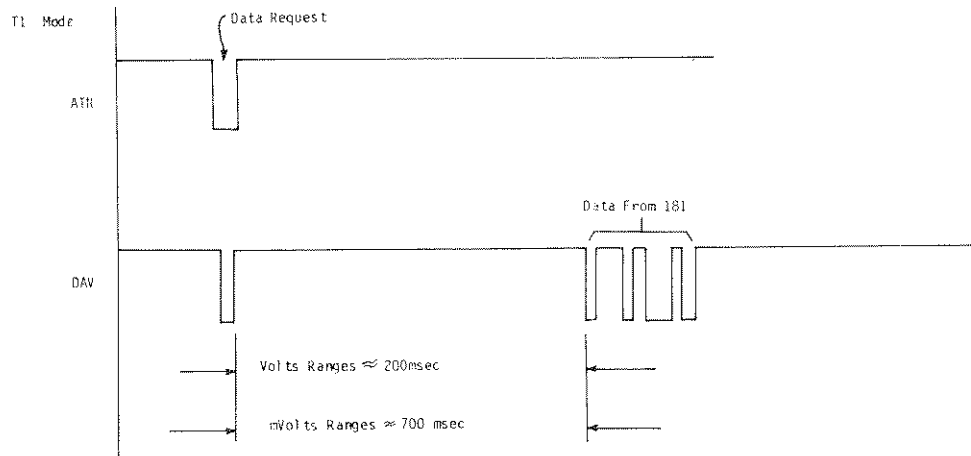
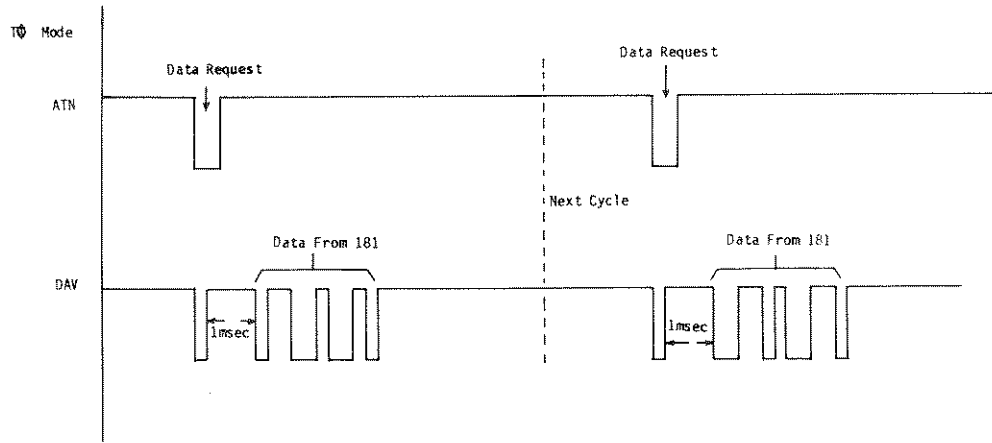







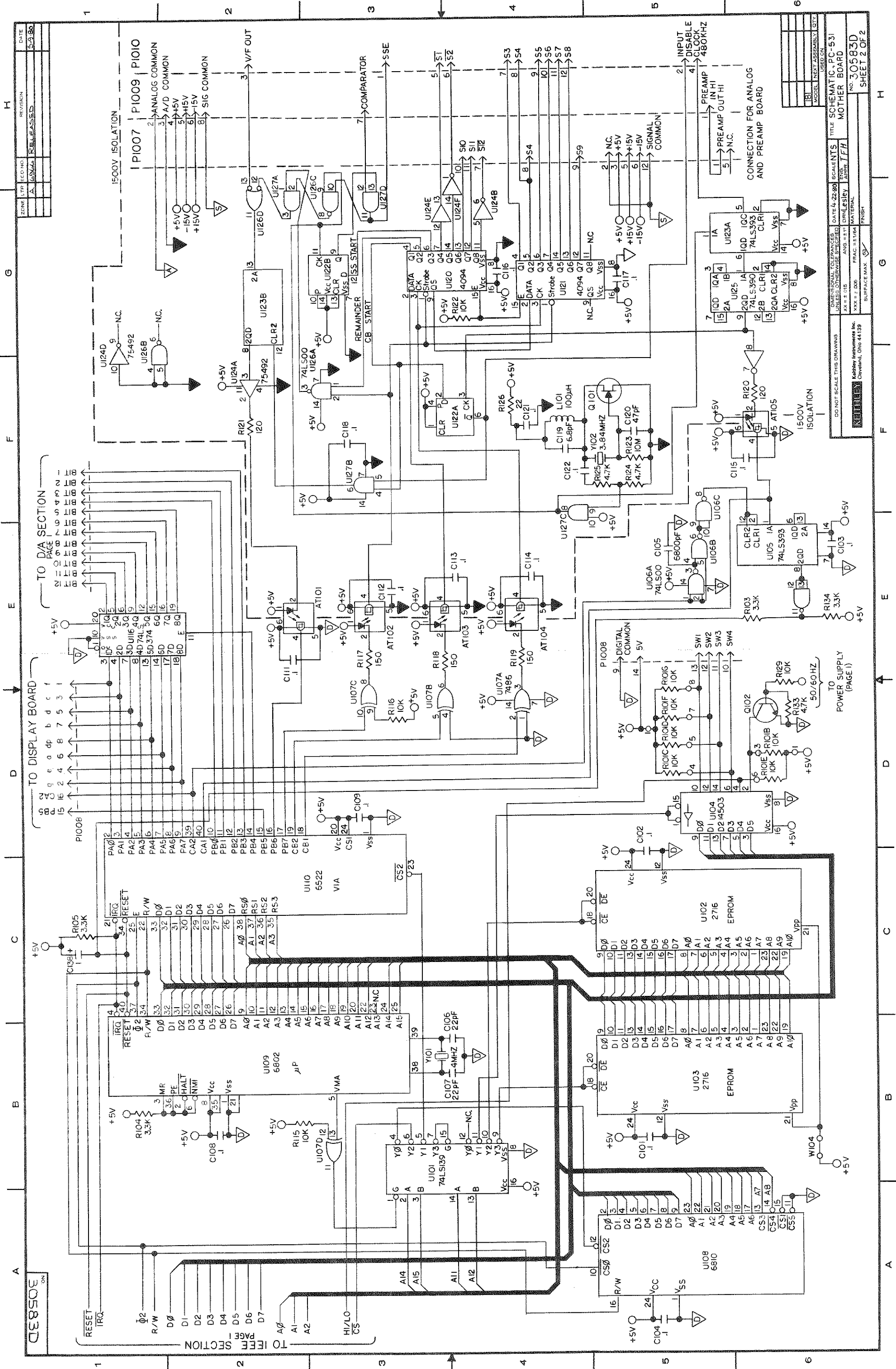

DATE	15-3-80
REVISION	RELEASED
ZONE	A 0544
TRF	
ECO NO.	

PI007	1500V ISOLATION
PI009	ANALOG COMMON
PI010	A/D COMMON
	+5V
	-15V
	+15V
	SIG COMMON

TO DISPLAY BOARD	a	1
	b	2
	c	3
	d	4
	e	5
	f	6
	g	7
	h	8
	i	9
	j	10
	k	11
	l	12
	m	13
	n	14
	o	15
	p	16
	q	17
	r	18
	s	19
	t	20
	u	21
	v	22
	w	23
	x	24
	y	25
	z	26
	aa	27
	ab	28
	ac	29
	ad	30
	ae	31
	af	32
	ag	33
	ah	34
	ai	35
	aj	36
	ak	37
	al	38
	am	39
	an	40
	ao	41
	ap	42
	aq	43
	ar	44
	as	45
	at	46
	au	47
	av	48
	aw	49
	ax	50
	ay	51
	az	52
	ba	53
	bb	54
	bc	55
	bd	56
	be	57
	bf	58
	bg	59
	bh	60
	bi	61
	bj	62
	bk	63
	bl	64
	bm	65
	bn	66
	bo	67
	bp	68
	bq	69
	br	70
	bs	71
	bt	72
	bu	73
	bv	74
	bw	75
	bx	76
	by	77
	bz	78
	ca	79
	cb	80
	cc	81
	cd	82
	ce	83
	cf	84
	cg	85
	ch	86
	ci	87
	cj	88
	ck	89
	cl	90
	cm	91
	cn	92
	co	93
	cp	94
	cq	95
	cr	96
	cs	97
	ct	98
	cu	99
	cv	100

TO D/A SECTION	1
	2
	3
	4
	5
	6
	7
	8
	9
	10
	11
	12
	13
	14
	15
	16
	17
	18
	19
	20
	21
	22
	23
	24
	25
	26
	27
	28
	29
	30
	31
	32
	33
	34
	35
	36
	37
	38
	39
	40
	41
	42
	43
	44
	45
	46
	47
	48
	49
	50
	51
	52
	53
	54
	55
	56
	57
	58
	59
	60
	61
	62
	63
	64
	65
	66
	67
	68
	69
	70
	71
	72
	73
	74
	75
	76
	77
	78
	79
	80
	81
	82
	83
	84
	85
	86
	87
	88
	89
	90
	91
	92
	93
	94
	95
	96
	97
	98
	99
	100

TO POWER SUPPLY (PAGE 1)	1
	2
	3
	4
	5
	6
	7
	8
	9
	10
	11
	12
	13
	14
	15
	16
	17
	18
	19
	20
	21
	22
	23
	24
	25
	26
	27
	28
	29
	30
	31
	32
	33
	34
	35
	36
	37
	38
	39
	40
	41
	42
	43
	44
	45
	46
	47
	48
	49
	50
	51
	52
	53
	54
	55
	56
	57
	58
	59
	60
	61
	62
	63
	64
	65
	66
	67
	68
	69
	70
	71
	72
	73
	74
	75
	76
	77
	78
	79
	80
	81
	82
	83
	84
	85
	86
	87
	88
	89
	90
	91
	92
	93
	94
	95
	96
	97
	98
	99
	100

TO INPUT DISABLE CLOCK 480KHZ	1
	2
	3
	4
	5
	6
	7
	8
	9
	10
	11
	12
	13
	14
	15
	16
	17
	18
	19
	20
	21
	22
	23
	24
	25
	26
	27
	28
	29
	30
	31
	32
	33
	34

KEITHLEY INSTRUMENTS, INC.  
28775 AURORA ROAD  
CLEVELAND, OHIO 44139  
**SERVICE FORM**

MODEL NO. \_\_\_\_\_ SERIAL NO. \_\_\_\_\_ P.O. NO. \_\_\_\_\_ DATE \_\_\_\_\_ R-

NAME \_\_\_\_\_ PHONE \_\_\_\_\_

COMPANY \_\_\_\_\_

ADDRESS \_\_\_\_\_ CITY \_\_\_\_\_ STATE \_\_\_\_\_ ZIP \_\_\_\_\_

1. Describe problem and symptoms using quantitative data whenever possible (enclose readings, chart recordings, etc.) \_\_\_\_\_

\_\_\_\_\_ (Attach additional sheets as necessary).

2. Show a block diagram of your measurement system including all instruments connected (whether power is turned on or not). Also describe signal source.

3. List the positions of all controls and switches on both front and rear panels of the instrument. \_\_\_\_\_

4. Describe input signal source levels, frequencies, etc. \_\_\_\_\_

5. List and describe all cables used in the experiment (length, shielding, etc.).

6. List and describe all other equipment used in the experiment. Give control settings for each. \_\_\_\_\_

7. Environment:  
Where is the measurement being performed? (Factory, controlled laboratory, out-of-doors, etc.) \_\_\_\_\_  
What power line voltage is used? \_\_\_\_\_ Variation? \_\_\_\_\_ Frequency? \_\_\_\_\_  
Ambient temperature? \_\_\_\_\_ °F. Variation? \_\_\_\_\_ °F. Rel. Humidity? \_\_\_\_\_  
Other \_\_\_\_\_

8. Additional Information. (If special modifications have been made by the user, please describe below.) \_\_\_\_\_



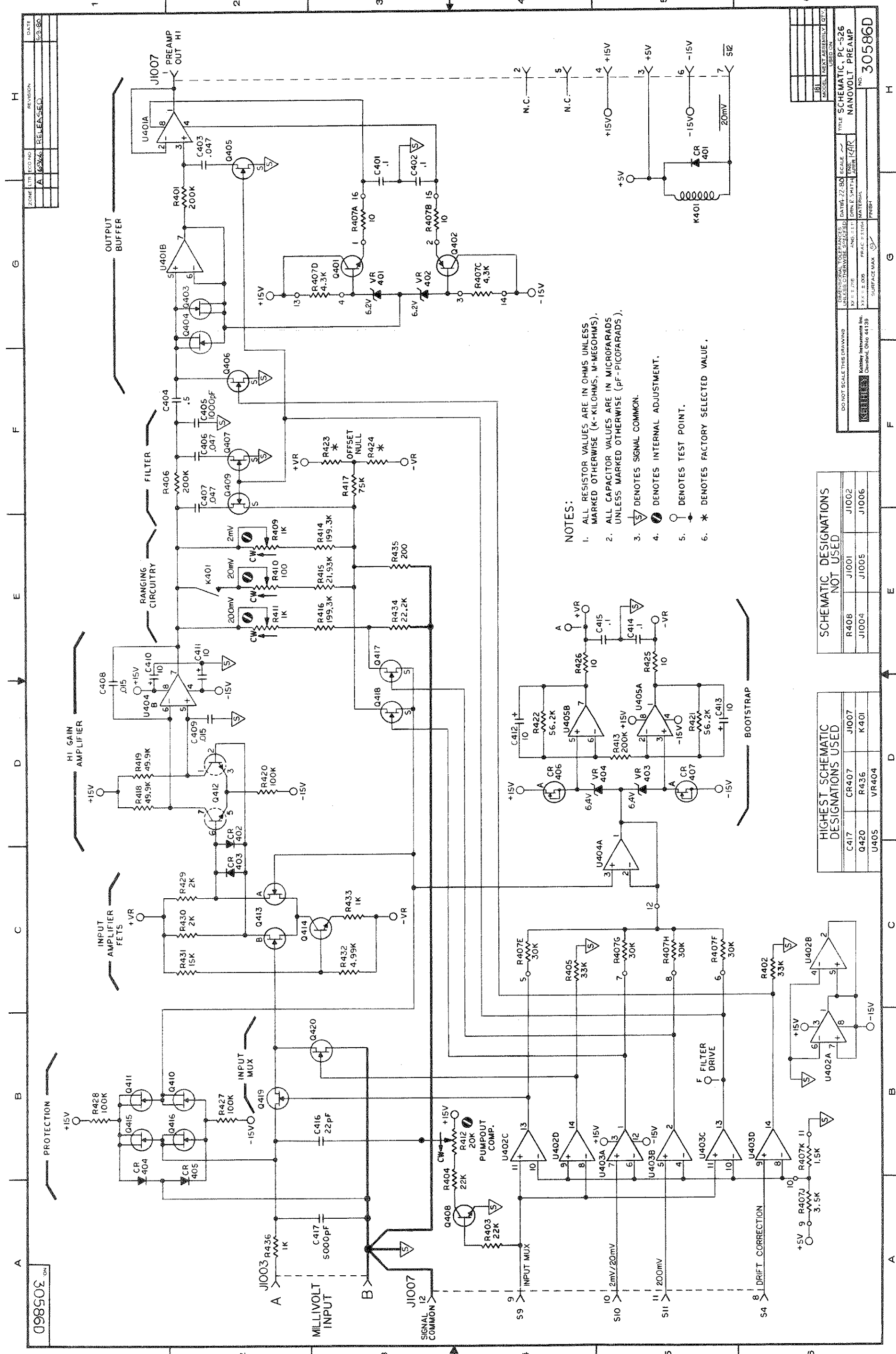

- NOTES:
1. ALL RESISTOR VALUES ARE IN OHMS UNLESS MARKED OTHERWISE (K-KILOHMS, M-MEGOHMS).
  2. ALL CAPACITOR VALUES ARE IN MICROFARADS UNLESS MARKED OTHERWISE (PF-PICOFARADS).
  3.  $\nabla$  DENOTES SIGNAL COMMON.
  4.  $\nabla$  DENOTES INTERNAL ADJUSTMENT.
  5.  $\circ$  DENOTES TEST POINT.
  6. \* DENOTES FACTORY SELECTED VALUE.

SCHEMATIC DESIGNATIONS NOT USED

R408	J1001	J1002
J1004	J1005	J1006

HIGHEST SCHEMATIC DESIGNATIONS USED

C417	CR407	J1007
Q420	R435	K401
U405	VR404	

ZONE	EXTN	ECO-NO	REVISION	DATE
A	6366		RELEASED	5-3-50

DO NOT SCALE THIS DRAWING UNLESS OTHERWISE SPECIFIED.  
 X REF. TO: DRAWING NO. DATE: 22-80 SCALE: 1:1  
 UNLESS OTHERWISE SPECIFIED: DRN. E. SMITH  
 MATERIALS: SURFACE MAX  
 FINISH: KATHLEY INSTRUMENTS INC. CLEVELAND, OHIO 44139

TITLE: SCHEMATIC, PC-526  
 NANOVOLT PREAMP  
 NO. 30586D



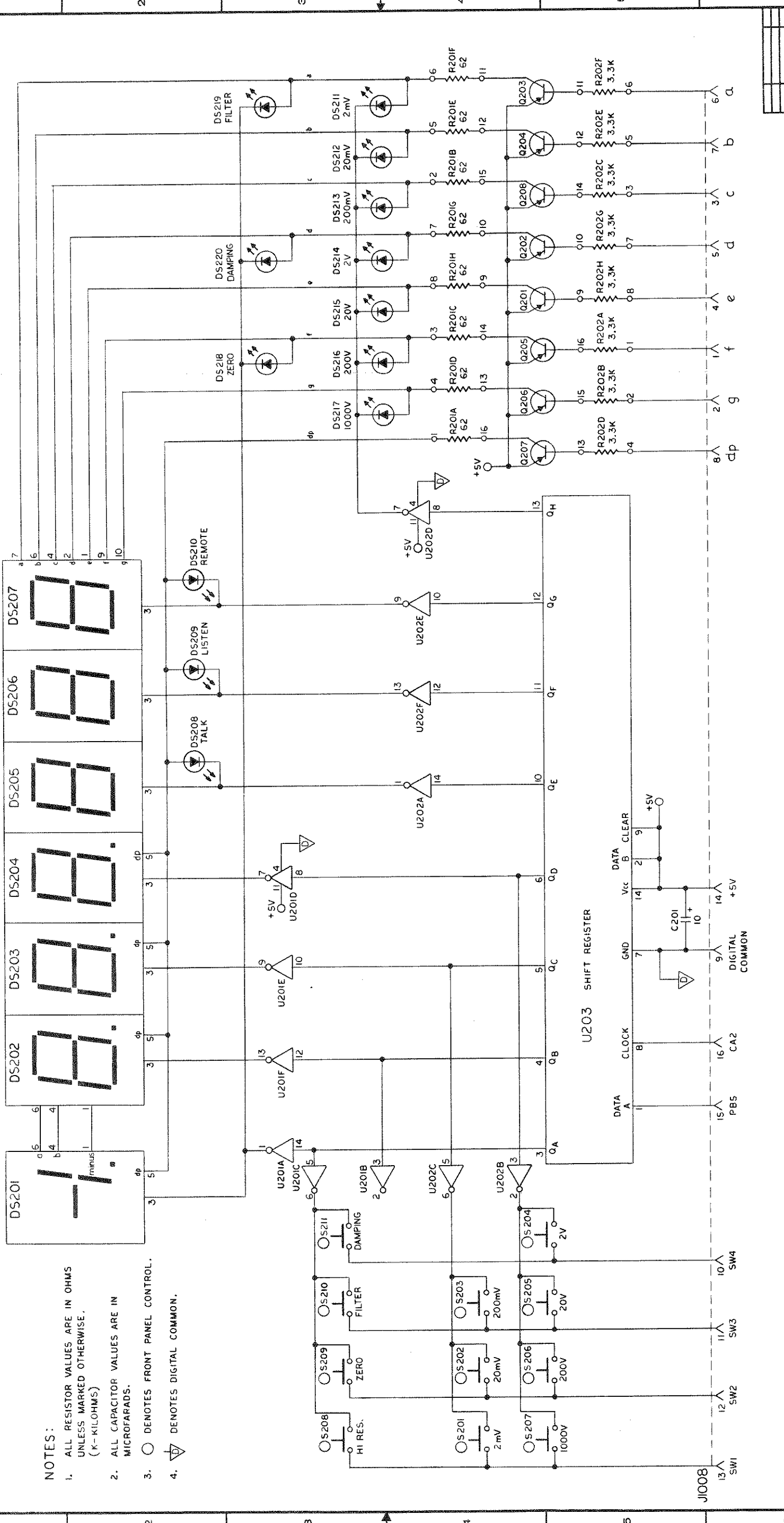

- NOTES:
1. ALL RESISTOR VALUES ARE IN OHMS UNLESS MARKED OTHERWISE. (K - KILOHMS)
  2. ALL CAPACITOR VALUES ARE IN MICROFARADS.
  3. ○ DENOTES FRONT PANEL CONTROL.
  4. ▽ DENOTES DIGITAL COMMON.

HIGHEST SCHEMATIC DESIGNATIONS USED

C201	DS220	Q208
R202	S211	U203
J1008		

SCHEMATIC DESIGNATIONS NOT USED

J1001 THRU J1007
------------------

DO NOT SCALE THIS DRAWING UNLESS OTHERWISE SPECIFIED. SCALE: DATA-17-80. XX = 1:1. ANS = 1:1. DPN, R. SWITH, 1000, VAK. XXX = 2:505. FRACTION = 1:104. MATERIAL: FINISH: SURFACE: MAX. 63.

30584D

30584D

