

INSTRUCTION MANUAL

Digital Multimeter

Model 179/179-20A

COPYRIGHT 1978, KEITHLEY INSTRUMENTS, INC.

THIRD PRINTING, FEBRUARY 1980, CLEVELAND, OHIO U. S. A.

DOCUMENT NO. 28973



# SPECIFICATIONS

## DC VOLTAGE

RANGE	MAXIMUM READING	ACCURACY (12 months)		MAXIMUM ALLOWABLE INPUT
		18°-28°C ±(% rdg + digits)		
200mV	199.99	0.04% + 3d		1200V momentary
2 V	1.9999	0.04% + 1d		1200V momentary
20 V	19.999	0.04% + 1d		1200V
200 V	199.99	0.04% + 1d		1200V
1200 V	1200.0	0.04% + 1d		1200V

Temperature Coefficient (0°-18° and 28°-55°C):  
 $\pm(0.006\% + 0.2 \text{ digit})/^{\circ}\text{C}$  except  $\pm(0.006\% + 0.4 \text{ digit})/^{\circ}\text{C}$   
on the 200mV range.  
Input Resistance: 10M $\Omega$   $\pm$ 0.1%

Normal Mode Rejection Ratio:  
Greater than 60dB at 50Hz and 60Hz.  
Common Mode Rejection Ratio (1k $\Omega$  unbalance):  
Greater than 120dB at DC, 50Hz and 60Hz.  
Settling Time: 1 second to within 1 digit of final reading.

## AC VOLTAGE

RANGE	MAXIMUM READING	ACCURACY (12 months)		TEMPERATURE COEFFICIENT	
		18°-28°C: 100Hz-10kHz ±(% rdg + digits)		0°-18° and 28°-55°C ±(% rdg + digits)/°C	
200mV	199.99	0.7% + 15d		45Hz-10kHz	0.07% + 2d
2 V	1.9999	0.6% + 15d		10kHz-20kHz	0.15% + 3d
20 V	19.999	0.5% + 15d			0.05% + 2d
200 V	199.99	0.5% + 15d			0.05% + 2d
1000 V	1000.0	0.5% + 15d			0.05% + 2d

Extended Frequency Accuracy:  
-(45Hz-100Hz)  $\pm(0.7\% + 15 \text{ digits})$   
(10kHz-20kHz)  $\pm(0.8\% + 15 \text{ digits})$  on the 20V and higher  
ranges,  $\pm(1.5\% + 15 \text{ digits})$  on the 2V range,  $\pm(2\% + 15 \text{ digits})$   
on the 200mV range.  
Response: True root mean square.  
Crest Factor: 3.

Input Impedance:  
1M $\Omega$   $\pm$ 1% shunted by less than 75pF.  
Maximum Allowable Input Voltage:  
1000V rms, 1400V peak, 10<sup>7</sup>V/Hz maximum.  
Common Mode Rejection Ratio (1k $\Omega$  unbalance):  
60dB at DC, 50Hz and 60Hz.  
Settling Time: 2.5 seconds to within 10 digits of final reading.

## DC AND TRMS AC CURRENT

RANGE	MAXIMUM READING	ACCURACY (12 months)		MAXIMUM VOLTAGE BURDEN	SHUNT RESISTANCE
		18°-28°C			
		DC	AC 45Hz-10kHz (above 2000 counts)		
200 $\mu$ A	199.99	0.2% + 2d	1% + 15d	0.2 V	1k $\Omega$
2mA	1.9999	0.2% + 2d	1% + 15d	0.2 V	100 $\Omega$
20mA	19.999	0.2% + 2d	1% + 15d	0.2 V	10 $\Omega$
200mA	199.99	0.2% + 2d	1% + 15d	0.25V	1 $\Omega$
2000mA	1999.9	0.2% + 2d	1% + 15d	0.5 V	0.1 $\Omega$
20 A**	19.999	0.5% + 2d	1% + 15d* (1kHz max)	0.65V	0.01 $\Omega$

\*Add 0.1% rdg above 15A for self-heating.  
\*\*20A range on Model 179-20A only.  
MAXIMUM INPUT: 2A, 250V DC or rms (fuse protected)  
except for 20A range.  
15A continuous, 20A for 1 minute (50% duty cycle),  
250V dc or rms (fuse protected) on 20A range.

Temperature Coefficient (0°-18° and 28°-55°C):  
DC  $\pm(0.01\% + 0.2 \text{ digits})/^{\circ}\text{C}$ ,  
AC  $\pm(0.07\% + 2 \text{ digits})/^{\circ}\text{C}$ .  
Crest Factor: 3  
Settling Time: DC: 1 second to within 1 digit of final reading,  
AC: 2.5 seconds to within 10 digits of final reading.

## RESISTANCE

RANGE	MAXIMUM READING	ACCURACY (12 months)		MAXIMUM VOLTAGE ACROSS UNKNOWN ON RANGE		TEMPERATURE COEFFICIENT		NOMINAL APPLIED CURRENT	
		18°-28°C		0°-18° and 28°-55°C		±(% rdg + digits)/°C			
		HI $\Omega$	LO $\Omega$	HI $\Omega$	LO $\Omega$	HI $\Omega$	LO $\Omega$	HI $\Omega$	LO $\Omega$
2 k $\Omega$	1.9999	-	0.15% + 15d	-	0.2V	-	0.02% + 2d	-	100 $\mu$ A
20 k $\Omega$	19.999	0.04% + 1d	0.15% + 15d	2V	0.2V	0.003% + 0.2d	0.02% + 2d	100 $\mu$ A	10 $\mu$ A
200 k $\Omega$	199.99	0.04% + 1d	0.15% + 15d	2V	0.2V	0.003% + 0.2d	0.02% + 2d	10 $\mu$ A	1 $\mu$ A
2000 k $\Omega$	1999.9	0.04% + 1d	0.15% + 15d	2V	0.2V	0.003% + 0.2d	0.03% + 2d	1 $\mu$ A	0.1 $\mu$ A
20M $\Omega$	19.999	0.10% + 1d	-	2V	-	0.02% + 0.2d	-	0.1 $\mu$ A	-

Maximum Allowable Input:  
450V rms sustained, 1kV DC or peak AC momentary.  
Maximum Open-Circuit Voltage: 5 volts.

Settling Time: 1 second to within 1 digit of final reading except  
2 seconds on the 20M $\Omega$  range.

## GENERAL

DISPLAY: Five 0.5" LED digits, appropriate decimal position  
and polarity indication.  
CONVERSION PERIOD: 400 milliseconds.  
ENVIRONMENT:  
Operating: 0°C to 55°C.  
0% to 80% relative humidity up to 40°C.  
Storage: -25°C to +65°C.

POWER: 105-125 or 210-250 volts (switch selected), 90-110V  
available, 50-60Hz, 7 watts. Optional 6 hour battery pack,  
Model 1788.  
DIMENSIONS, WEIGHT: 85mm high x 235mm wide x 275mm  
deep (3-1/2 in. x 9-1/4 in. x 10-3/4 in.).  
Net weight: 1.7kg, (3 lbs., 13 oz.).  
OVERRANGE INDICATION: Display blinks all zeros above  
19999 counts.  
MAXIMUM COMMON MODE VOLTAGE: 1400V peak.

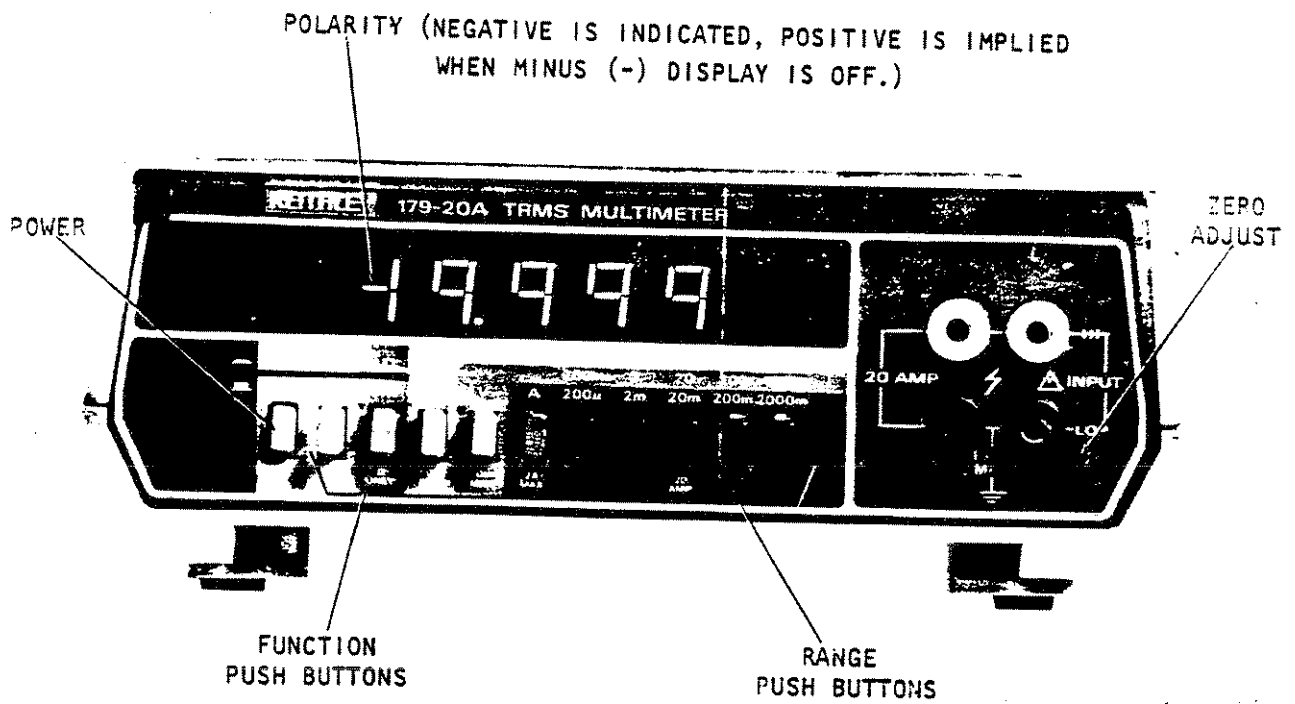

FIGURE 1-1. Front Panel.

**SECTION 1. GENERAL INFORMATION.**

1-1. **INTRODUCTION.** The Models 179 and 179-20A are versatile digital multimeters useful for measurement of ac and dc voltage, ac and dc current and resistance. The Model 179-20A is identical to the Model 179, except for an added 20-ampere range. This extra range uses separate input terminals and allows continuous measurement of up to 15A ac/dc, or intermittent duty measurements up to 20A ac/dc. The Model 179-20A is treated by the exception method in this manual. That is, information headed by Model 179-20A applies only to the Model 179-20A. Information headed by Model 179 is common to both the Model 179 and the Model 179-20A. Ranges and accuracies for both models are listed in the Table of Specifications on page v. Ranges and functions are selected with front panel pushbuttons. The decimal point is also positioned by the selected range pushbutton. Polarity of the measured signal is automatically displayed.

1-2. **WARRANTY INFORMATION.** The Warranty is given on the inside front cover of this Instruction Manual. If there is a need to exercise the Warranty, contact the Keithley Representative in your area to determine the proper action to be taken. Keithley maintains service facilities in the United Kingdom and West Germany, as well as in the United States. Check the inside front cover of the Instruction Manual for addresses.

1-3. **CHANGE NOTICES.** Improvements or changes to the instrument which occur after printing of the Instruction Manual will be explained on a Change Notice sheet attached to the inside back cover.

**IMPORTANT**

The  symbol can be found in various places in this Instruction Manual. Carefully read the associated CAUTION statements with regard to proper use and handling of the instrument. Damage to the instrument may occur if these precautions are ignored.

The  symbol can be found in various places in this Instruction Manual. This symbol indicates those areas on the instrument which are potential shock hazards. Carefully read the associated WARNING statements with regard to proper use and handling of the instrument. Serious personal injury may result if these precautions are ignored.

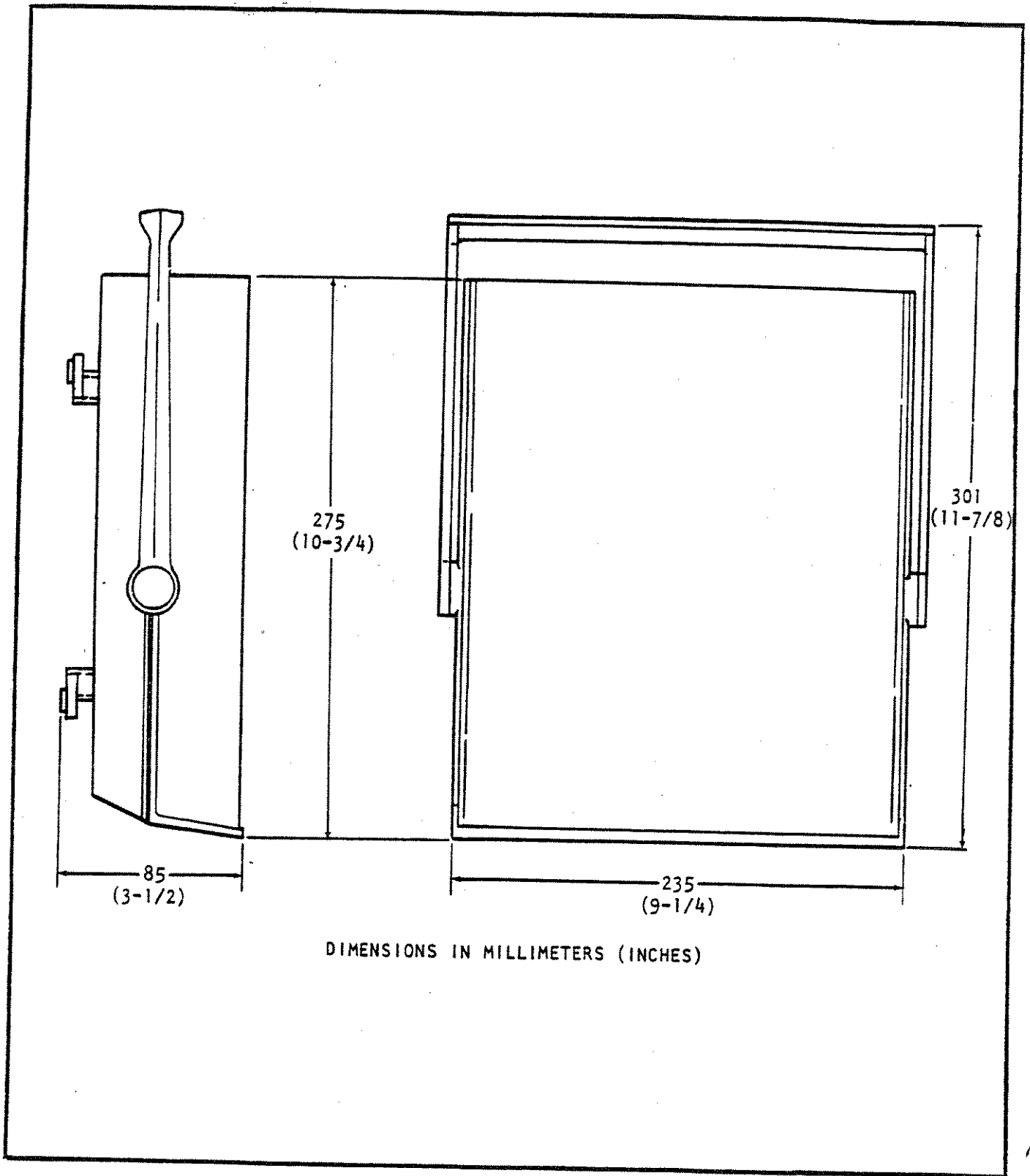

FIGURE 1-2. Dimensional Data

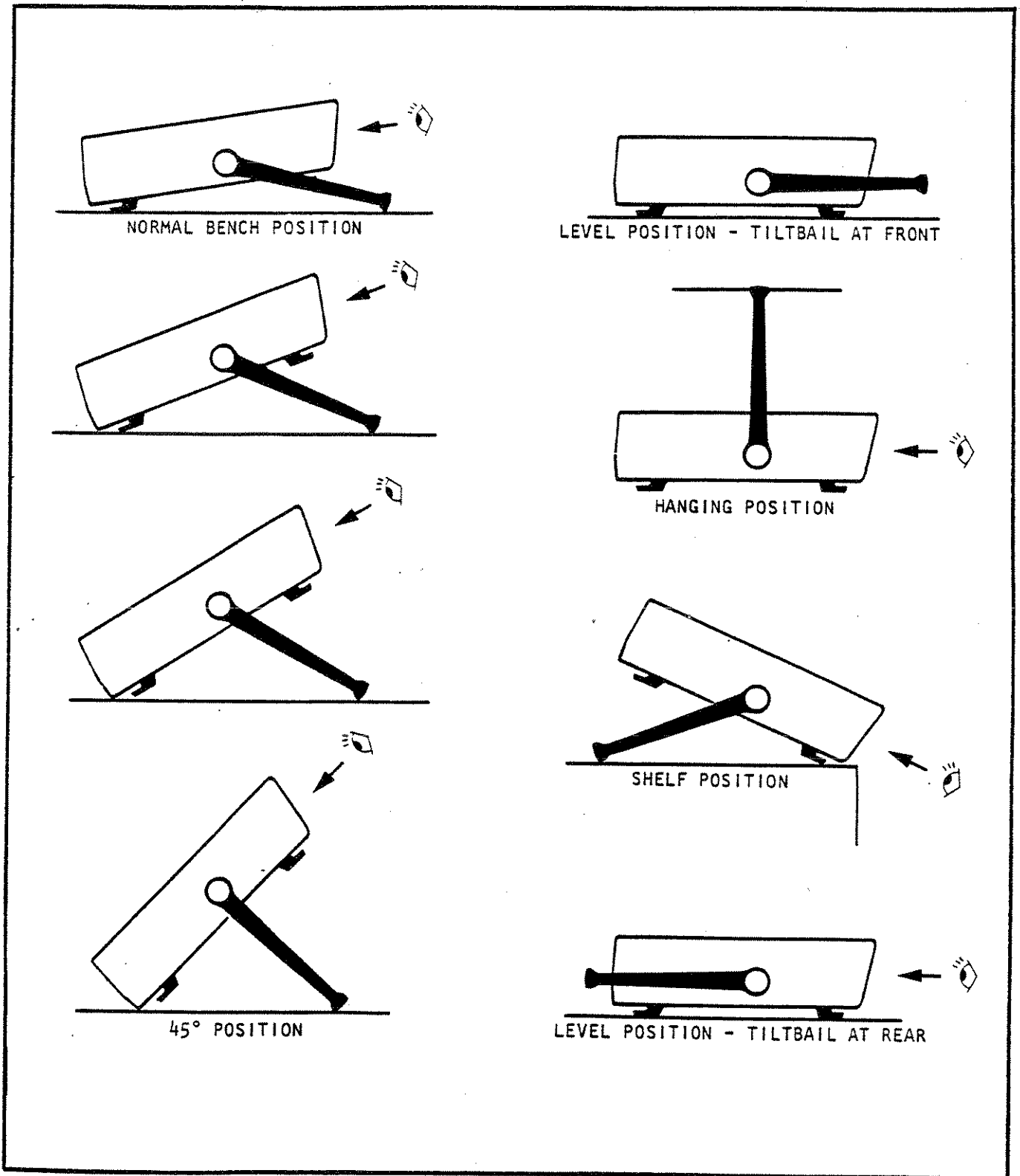

FIGURE 1-3. Tilt Bail Positions.





**SECTION 2. OPERATION.**

2-1. GENERAL. This section provides information needed for incoming inspection and preparation for use.

2-2. INSPECTION. The Model 179 was carefully inspected both mechanically and electrically before shipment. Upon receiving the instrument, check for any obvious damage which may have occurred during transit. Report any damages to the shipping agent. To verify the electrical specifications, follow the procedures given in Section 3.

2-3. PREPARATION FOR USE. The Model 179 is shipped ready-to-use. The instrument may be powered from line voltage or from rechargeable batteries (when the optional Model 1788 Rechargeable Battery Set is installed).

2-4. OPERATION ON LINE POWER. The Model 179 DMM is provided with a three-wire line cord which mates with third-wire grounded receptacles. Connect the instrument to ac line power as follows:

**CAUTION**

⚠ Connect only to the line voltage selected. Application of incorrect voltage can damage the instrument.

a. Set the LINE VOLTAGE switch on the back of the instrument to correspond to the line voltage available. Ranges are 105 to 125 volts and 210 to 250 volts ac as shown in Figure 2-1.

**WARNING**

⚡ Ground the instrument through a properly grounded receptacle before operation. Failure to ground the instrument can result in severe injury or death in the event of short circuit or malfunction.

b. Plug the power cord into a properly grounded outlet. Operate the 179 DMM as described in SECTION 2-7.

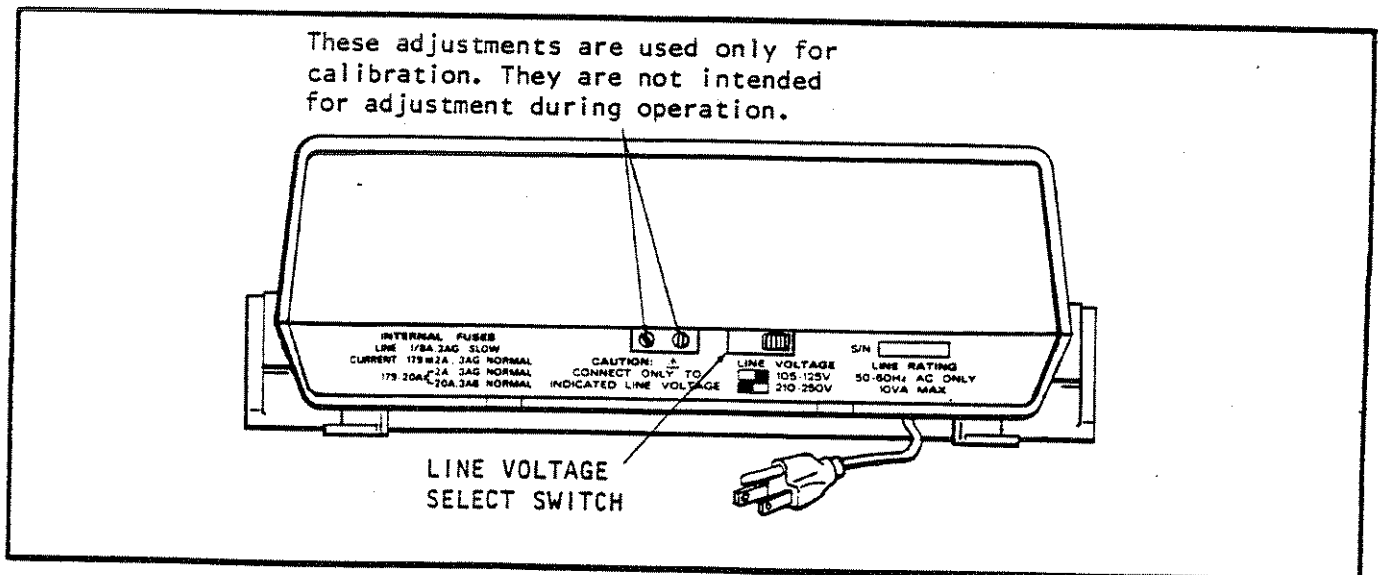

FIGURE 2-1. Rear View Showing Line Switch.

2-5. OPERATION ON BATTERY PACK POWER. The Model 179 DMM may also be operated from rechargeable sealed lead-acid batteries contained in the optional Model 1788 Battery Pack. The battery pack will operate the 179 DMM for up to 6 hours. Circuits within the battery pack will automatically shut down the instrument when the battery charge is insufficient to maintain accurate readings. Refer to Figure 2-2 and install the battery pack as follows:

 WARNING

Disconnect the line cord before removing the case cover.

- a. Turn off the power and disconnect the line cord. Remove four screws from the bottom of the case and separate the top cover from the bottom cover.
- b. Lift off the calibration shield, and save it for later use. The four plastic spacers must remain in place on the upright studs projecting through the main circuit board.

## NOTE

Do not discard the calibration shield. This shield must be installed during calibration, as described in Section 4.

- c. Set the BAT/LINE switch to the BAT position shown in Figure 2-2. Note that the battery pack will not operate properly if this switch is not in the BAT position.
- d. Remove fuse F301 on the battery pack.
- e. Install the battery pack in the instrument so that it rests on the plastic spacers. The ground clip must make contact with the upper side of the battery pack plate.
- f. Carefully align the battery pack plug with connector P1004 on the circuit board. Push the plug firmly onto the connector until the lip on the plug engages the lip on the connector to lock the plug in place.

## CAUTION

 Make sure the connector is aligned so that all pins mate properly, otherwise, damage to the DMM will result.

- g. Install fuse F301. Reinstall top cover and secure with four screws.
- h. Charge the battery pack as described in Paragraph 2-6.

2-6. BATTERY CHARGING. The Model 1788 Battery Pack contains an integral battery charger. To charge or recharge the battery pack, install the battery pack in the 179 DMM as described above and proceed as follows:

- a. Connect the instrument to line power as described in Paragraph 2-4.
- b. With the power switch off, the battery charge circuitry is automatically energized to charge the battery at the maximum rate. When the battery pack is first installed, or if it has completely discharged, allow it to charge for at least 14 hours in this condition.

## NOTE

For maximum battery life, do not allow the battery pack to remain completely discharged. Constant charging will not harm either the battery pack or the instrument.

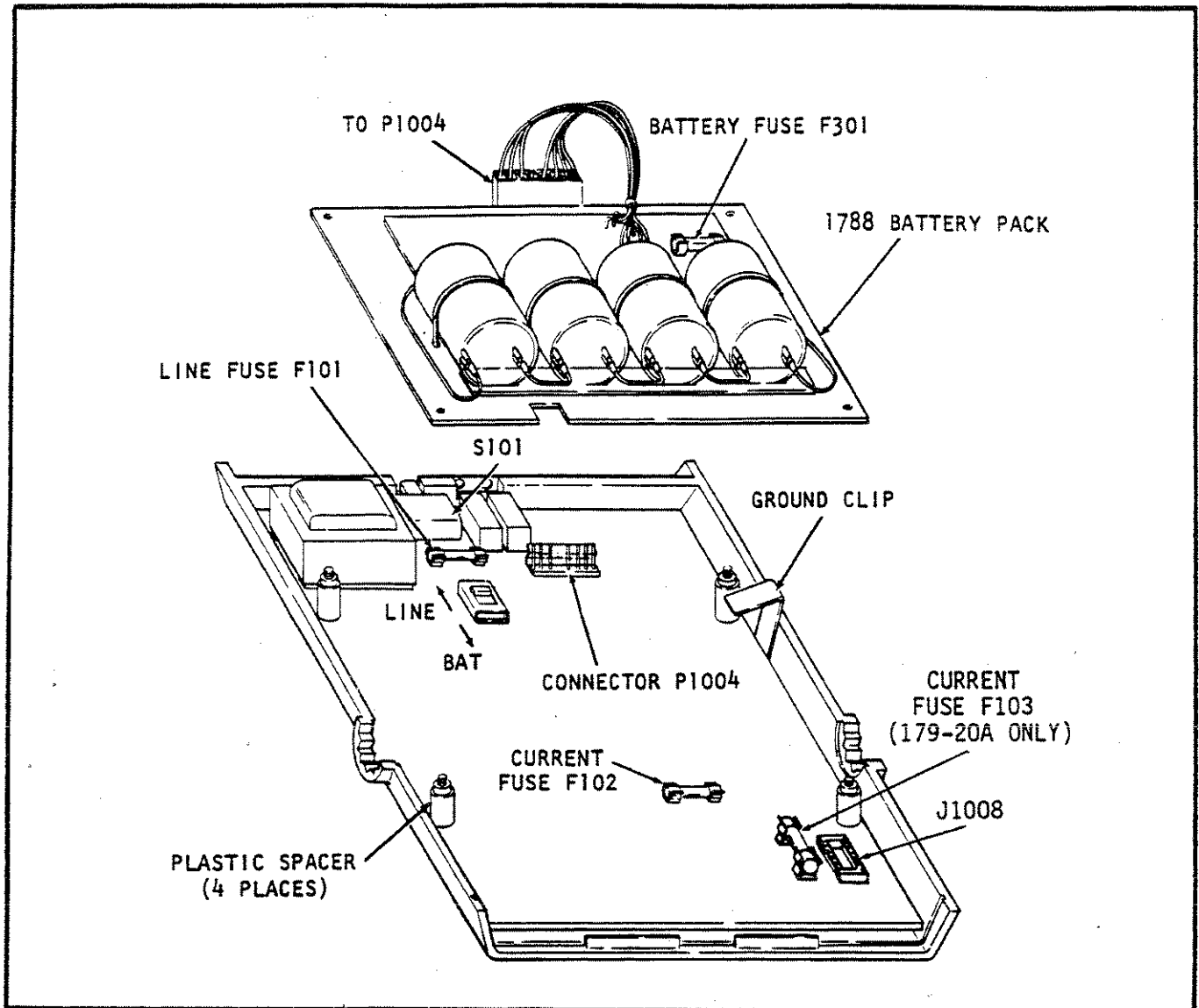

**FIGURE 2-2. Battery Pack Installation**

c. When the 179 DMM is in use on line power, the battery charger maintains a trickle charge on the battery pack.

2-7. OPERATING INSTRUCTIONS. Refer to Figure 2-3 and operate the DMM as follows:

- a. Turn on the power by depressing the ON/OFF pushbutton.
- b. Select the function with the AC/DC,  $\Omega$ , V, or A pushbuttons.
- c. Select the range by depressing the appropriate pushbutton. For resistance measurements only, also set the LO/HI pushbutton as desired.
- d. Connect the source to the INPUT terminals. Accessories described in Paragraph 2-14 should be used as required.

CAUTION

MAXIMUM RATINGS: 

- DCV (200mV, 2V): 450V rms continuous; 1200V peak, for 8 seconds per minute.  
(20-1200V): 1200V peak.
  - ACV (All Ranges): 1000V rms; 1400V peak;  $10^7$ V·Hz.
  - DCA,ACA (200 $\mu$ A-2000mA): 2A, 250V DC or rms (fuse protected)  
(20A): 15A continuous, 20A for 1 minute (50% duty cycle),  
250V dc or rms (fuse protected)
  - $\Omega$  (All Ranges): 450V rms sine wave; 1000V peak, for 8 seconds per minute.
- 2-8. DC VOLTAGE MEASUREMENT. Use the Model 179 DMM to measure dc volts as follows:
- a. Turn on power and set the AC/DC pushbutton to the out or DC position. Depress the V pushbutton.
  - b. Select the desired range from the five ranges available. The maximum reading is 19999. Overrange is indicated by a flashing 0000 except on the 1000 volt range.

CAUTION

 Do not exceed the maximum ratings. Instrument damage may occur.

- c. Negative polarity is displayed automatically. Positive polarity is implied when the minus (-) display is off.
- d. Zero the instrument as described in Paragraph 2-14, before the first use whenever the instrument is used outside the temperature range of 18° to 28°C, and approximately weekly during normal use.

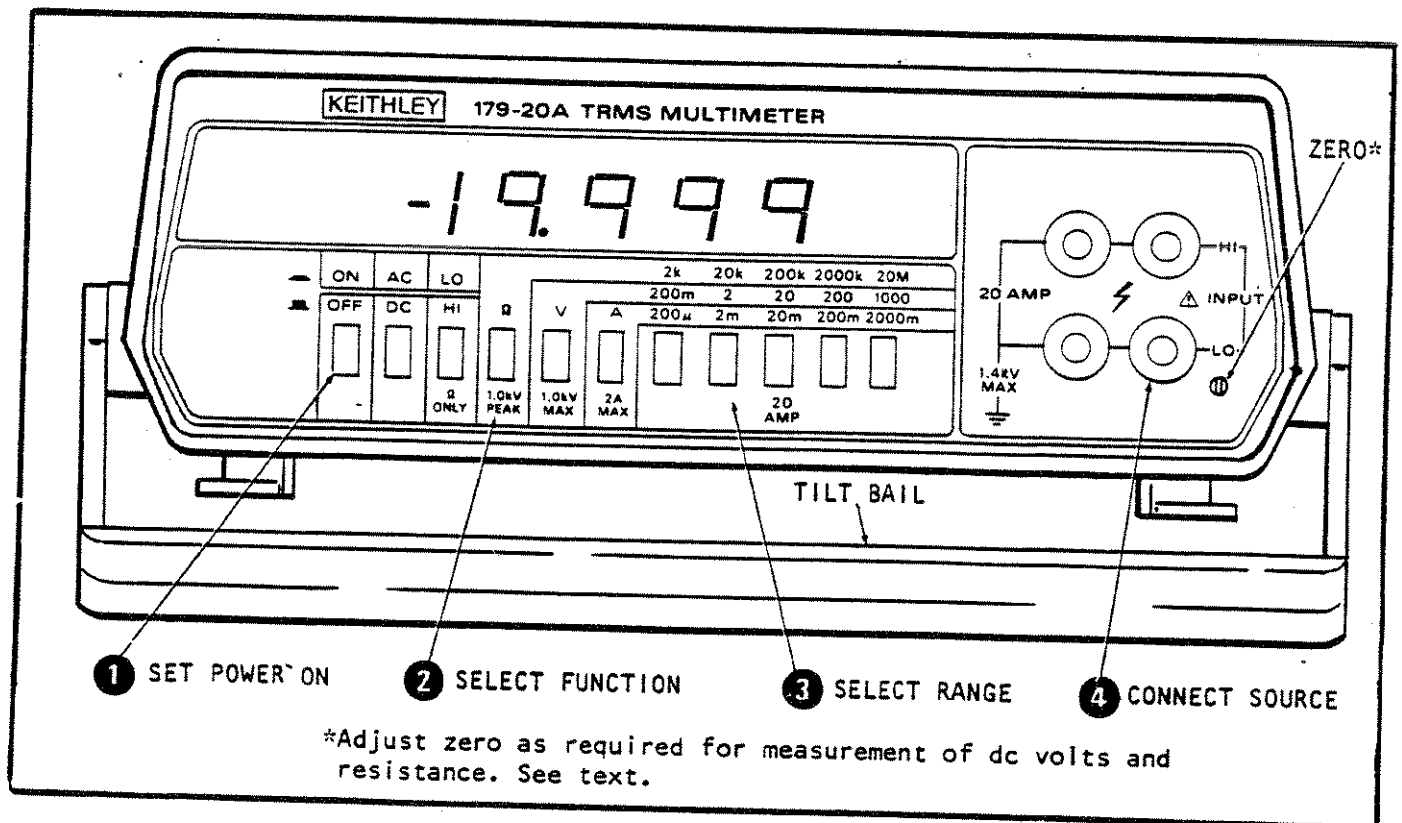



FIGURE 2-3. Operating Controls.

2-9. AC VOLTAGE MEASUREMENT. Use the Model 179 DMM to measure ac volts as follows:

- a. Turn on power and set the AC/DC pushbutton to the in or AC position. Depress the V pushbutton.

**CAUTION**

 Do not exceed the maximum ratings. Instrument damage may occur.

- b. Select the desired range from the five ranges available. The maximum reading is 19999. Overrange is indicated by a flashing 0000 except on the 1000 volt range. The instrument measures the true root mean square of a signal within the frequency range of 45 to 20k hertz. Maximum crest factor for rated accuracy is 3.

- c. The Model 1682 RF Probe (see Paragraph 2-15) should be used to measure ac voltages with a frequency of 20k to 100M hertz.

- d. Refer to Paragraph 2-13 for TRMS measurements of a signal with both ac and dc components.

2-10. RESISTANCE ( $\Omega$ ) MEASUREMENT. Use the 179 DMM to measure resistance as follows:

- a. Turn on power and depress the  $\Omega$  pushbutton.

**CAUTION**

 Do not exceed the maximum ratings. Instrument damage may occur.

- b. Select the desired range from the five ranges available. The maximum reading is 19999. Overrange is indicated by a flashing 0000. Use the LO/HI pushbutton as follows:

- 1) Use the HI mode for measurements in the 20k, 200k, 2000k and 20M ohm ranges. Full range voltage drop is 2 volts and is sufficient to cause forward conduction of semiconductor junctions. The HI terminal is positive.

- 2) Use the LO mode for measurements in the 2k, 20k, 200k and 2000k ohm ranges. Full range voltage drop is 200 millivolts. Depressing 2k automatically selects LO mode; 20M selects HI mode. Maximum open circuit voltage is 5V on all ranges.

- c. Zero the instrument as described in Paragraph 2-14 before the first use whenever the instrument is used outside the temperature range of 18° to 28°C, and approximately weekly during normal use.

2-11. CURRENT MEASUREMENT (AC or DC). Use the Model 179 or 179-20A to measure ac or dc as follows:

**NOTE**

To prevent measurement errors when using the Model 179-20A, connect the current test leads to either the 20A jacks or the normal INPUT jacks. Disconnect all circuits from the unused jacks.

- a. Turn on power and set the AC/DC pushbutton to the desired AC or DC position. Depress the A pushbutton.

**CAUTION**

 Do not install larger capacity fuses than those supplied. F102 (2A) and F103 (20A, supplied with Model 179-20A only) protect the instrument against overcurrent. Normal acting fuses are used.

- b. Select the desired range from the five/six ranges available. (On the Model 179-20A, the 20mA/20A pushbutton selects the 20mA range for the normal INPUT jacks and the 20A range for the 20A jacks). Connect the source to the INPUT jacks for current measurements up to 2000mA. (For current measurements between 2000mA and 20A, connect the source to the 20A

jacks on the Model 179-20A). The maximum reading is 19999. Overrange is indicated by a flashing 0000. Overload is fuse protected. When using the 20A current range of the Model 179-20A, up to 15A may be applied continuously without degradation of the measurement due to self-heating effects. For currents between 15A and 20A, specified accuracy can only be obtained when measurements are limited to a 50% duty cycle (i.e., apply the current for a maximum of one minute and then allow at least one minute for cooling before making the next measurement).

2-12. TRMS MEASUREMENT. The Model 179 measures the ac component of a waveform and does not measure the dc component. For ac + dc measurements, use the procedure discussed in a. below.

NOTE

Accuracy is specified for 2000 counts and above. The method of calibrating the converter may yield an offset up to 50 digits with the input shorted. This does not affect the instrument accuracy.

a. Use the 179 DMM to measure TRMS on a signal which has both ac and dc components as follows:

1. Turn on the power. Measure and record the ac and dc components separately.
2. Compute the rms value from the following equation:

$$E_{RMS} = \sqrt{E_{DC}^2 + E_{AC}^2}$$

b. The crest factor (CF) is the ratio of the peak voltage to the rms voltage as follows:

$$CF = \frac{V_{PEAK}}{V_{RMS}}$$

1. Typical crest factors are as follows:

Sine wave	$CF = \sqrt{2}$
Square wave	$CF = 1$
Triangular wave	$CF = \sqrt{3}$
Positive pulse train (duty cycle for CF = 3 is 0.11)	$CF = 1/\sqrt{\text{duty cycle}}$

NOTE

There will be some additional measurement error for signals with a crest factor greater than 3 (CF>3).

2-13. ZERO ADJUSTMENT. The front panel zero adjustment nulls input offset on the 20, 200 and 1200 dc voltage ranges and on all resistance ranges. Typically, this adjustment need not be performed more often than once a week unless the instrument is operated at ambient temperatures outside the range of 18° to 28°C. Zero the instrument as follows:

- a. Turn on the power and select L0 Ω and the 200k range.
- b. Plug in test leads and short them. Adjust the zero adjustment pot (R149) to obtain a reading of 0000 ±3 digits.

NOTE

The zero adjustment may also be used for lead compensation on a particular Ω range.



2-14. **ACCESSORIES.** A wide range of accessories is available to facilitate the use of the Model 179 DMM, extend its range, and adapt it for additional uses.

a. **Model 1600 High Voltage Probe.** The Model 1600 High Voltage Probe (shown in Figure 7) extends the measurable dc voltage range up to 40 kilovolts. It has a 1000:1 division ratio so that a reading of 1 volt on the DMM corresponds to 1 kilovolt (1000 volts). To use the probe, select DCV and the required range; connect the high voltage probe banana plug to the instrument, connect the alligator clip to source low, and touch the probe tip to source high.

**SPECIFICATIONS:**

Voltage Range: 0 to 40,000 volts DC.

Input Resistance: 1000 megohms.

Division Ratio: 1000:1.

Ratio Accuracy:

±1.5% at 25kV, decreasing to

±2.0% at 20kV and 30kV,

±3.0% at 10kV and 40kV, and

±4.0% at 1kV.

Ratio Stability: ±0.01% per °C; ±0.1% per year.

Heating Effects: Self-heating due to application of high voltage for period in excess of 1 minute will cause a maximum of 0.2% additional error at 40kV (error is less at lower voltage).

**WARNING**

⚡ Be sure alligator clip is connected to source low before touching probe tip to source high. A shock hazard or damage to instrument may result.

b. **Model 1651 50-Ampere Shunt.** The Model 1651 50-Ampere Shunt (shown in Figure 2-5) permits current measurements from 0-50A dc and from 20-50A ac. The shunt has a resistance of 0.001 ohm ±1%, so that a 50-ampere current will correspond to a reading of 50 millivolt (0.0500 volt). Set the DMM to ACV or DCV and select the required range. To use the shunt connect the leads furnished with the shunt from the shunt screw terminals to the DMM input terminals. Use separate leads (not furnished) to connect the source to the hex head bolts. Be sure to use leads with a capacity of 30 amperes, or as needed.

c. **Model 1681 Clip-On Test Lead Set.** This set (shown in Figure 2-5) contains two leads with banana plugs at one end and spring-action clip-on probes at the other end. Plug the leads into the DMM and attach the probes to the source.

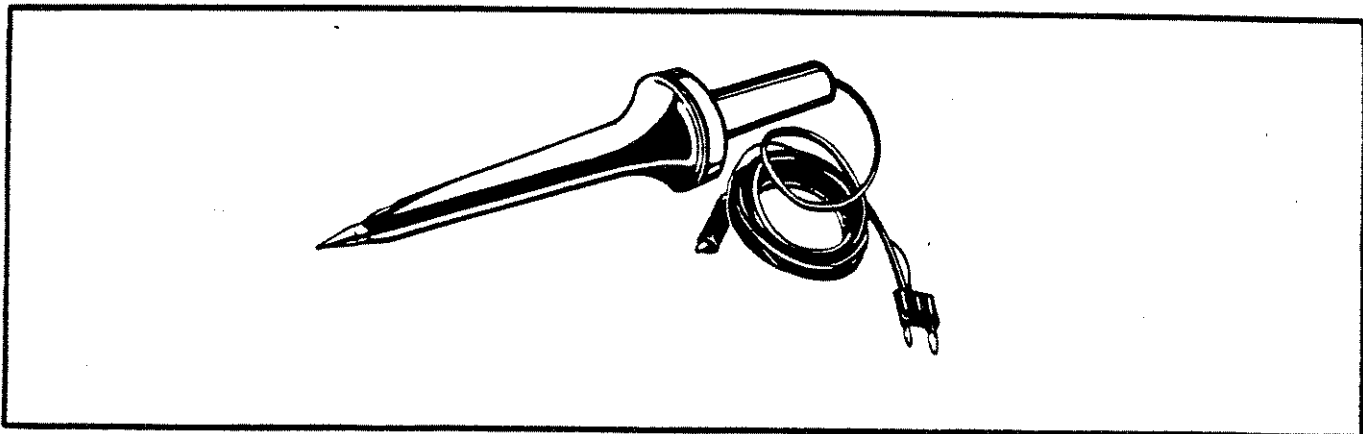

FIGURE 2-4. Model 1600 High Voltage Probe.

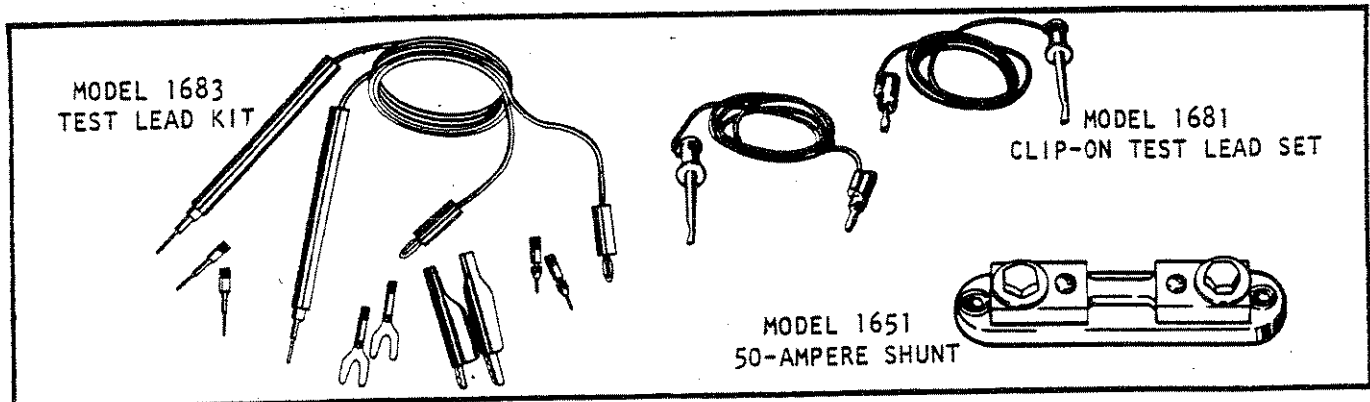

FIGURE 2-5. Accessories.

d. Model 1683 Universal Test Lead Kit. This kit (shown in Figure 2-5) contains two test leads, 14 tips, two probes, four banana plugs, two spade lugs, and two phone tips to permit connection of the DMM to virtually any source within its range.

e. Model 1682 RF Probe. The Model 1682 RF Probe (shown in Figure 2-6) permits measurement of ac voltages at frequencies of 20 kilohertz to 100 megahertz. Connect the probe to the input terminals and select ACV and the appropriate range.

SPECIFICATIONS:

Voltage Range: 0.25 to 30 volts rms.

Transfer Accuracy:  $\pm 0.5\text{dB}$ , 100kHz to 100MHz peak responding calibrated in rms of a sine wave.

Input Impedance: 4 megohm shunted by 3pF.

Maximum Allowable Input: 30V rms AC, 200V DC.

Accessories Supplied: straight tip, hook tip, ground clip, hi adapter, banana plug adapter.

f. Model 1685 Clamp-On AC Current Probe. The Model 1685 Clamp-On AC Current Probe (Shown in Figure 2-6) permits measurement of ac current by clamping around a single conductor, eliminating the need to interrupt the current path. Plug the ac current probe into the DMM and select ACV and the appropriate range. The DMM will display 0.1 volt rms per ampere.

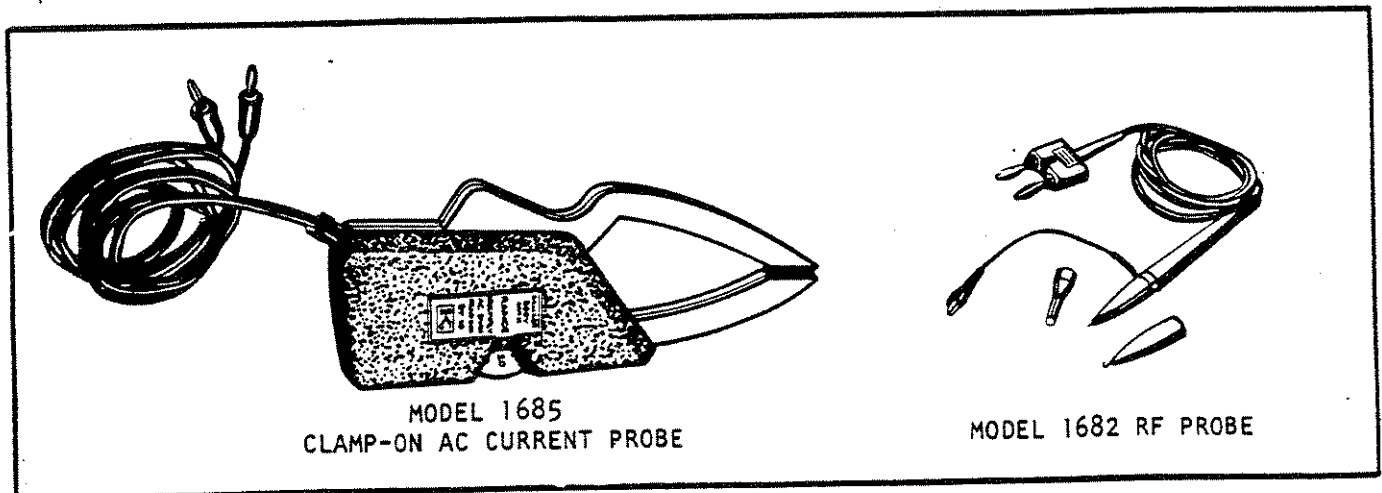

FIGURE 2-6. Model 1682 RF Probe and Model 1685 Clamp-On AC Current Probe.



SPECIFICATIONS:

Range: 2, 20 and 200 amperes rms.

Accuracy:  $\pm 4\%$  of ranges at 60Hz.  $\pm 6\%$  of range at 50Hz.

Temperature Coefficient:  $\pm 0.05\%/^{\circ}\text{C}$  on the 20 and 200 ampere ranges.  $\pm 0.3\%/^{\circ}\text{C}$  on the 2 ampere range.

Maximum Allowable Current: 300 amperes rms.

Maximum Conductor Voltage: 600 volts rms.

Conversion Ratio: 0.1 volt rms per ampere.

g. Model 1684 Carrying Case. The Model 1684 Carrying Case (Shown in Figure 2-7) is a hard vinyl case with a fitted foam insert to help protect the 179 DMM from damage. There is also room in the case for the service manual and other small accessories.

h. Models 1010 and 1017 Rack Mounting Kits. The rack mounting kits (shown in Figure 2-7) permit mounting one or two Model 179 DMM's in a rack for convenient viewing.

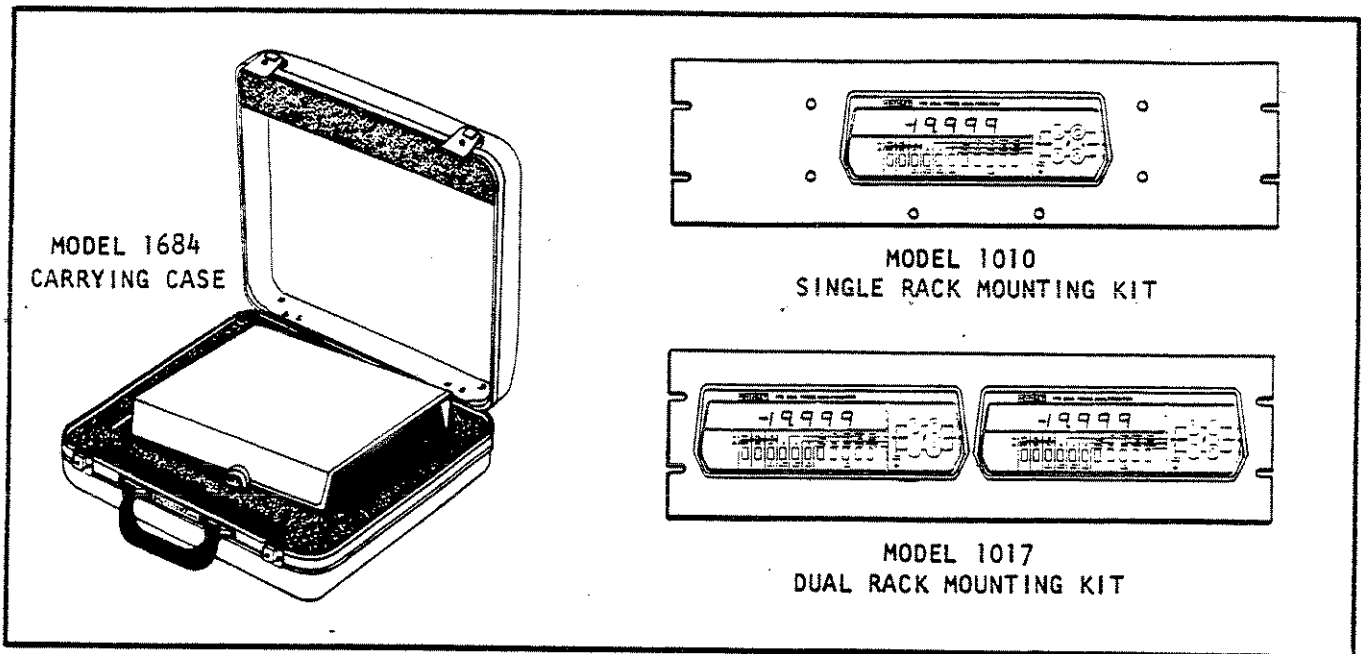

FIGURE 2-7. Carrying Case and Rack Mounting Kits.



SECTION 3. PERFORMANCE VERIFICATION.

3-1. GENERAL. Performance verification should be performed upon receipt of the instrument to ensure that no damage or misadjustment has occurred during transit. Verification may also be performed whenever there is question of the instrument's accuracy, and following calibration, if desired.

NOTE

For instruments that are still under warranty (less than 12 months since date of shipment), if the instrument's performance falls outside specifications at any point, contact your Keithley representative or the factory immediately.

3-2. RECOMMENDED TEST EQUIPMENT. Recommended test equipment for performance verification is listed in Table 3-1. Alternate test equipment may be used. However, if the accuracy of the alternate test equipment is not at least 10 times better than the instrument specifications, additional allowance must be made in the readings obtained.

3-3. ENVIRONMENTAL CONDITIONS. All measurements should be made at an ambient temperature within the range of 18° to 28°C (65° to 82°F), and a relative humidity of less than 80%.

3-4. PERFORMANCE VERIFICATION PROCEDURE. Use the following procedures to verify the basic accuracy of the Model 179 DMM for voltage, resistance and current measurements. If the instrument is out of specifications at any point, perform a complete calibration as described in Section 4, unless the instrument is still under warranty, as noted above.

TABLE 3-1.  
 Recommended Test Equipment For Performance Verification.

ITEM	DESCRIPTION	SPECIFICATION	MFR.	MODEL
A	DC Calibrator	0.1V, 1V, 10V, 100V, 1000V ±0.002% or 20µV	Fluke	343A
B	AC Calibrator	0.1V, 1V, 10V, 100V ±0.022%	H-P	745A
C	AC Calibrator/Amplifier	1000V @ ±0.04%	H-P	745A/746A
D	Decade Resistor	1.9KΩ, 19KΩ, 190KΩ 1.9MΩ, 19MΩ, ±0.01%	ESI	RS725
E	Current Calibrator	100µA, 1mA, 10mA, 100mA, 1A, 10A, ±0.03%	VALHALLA	2500E

NOTE

Performance verification should be performed by qualified personnel using accurate and reliable test equipment.

a. Initial Conditions. Before beginning the verification procedure the instrument must meet the following conditions:

- 1) If the instrument has been subjected to extremes of temperature, allow internal temperatures to stabilize for one hour minimum at the environmental conditions specified in Paragraph 3-3.
- 2) Turn on the 179 DMM and allow it to warm up for 10 minutes. The instrument may be operated from either line power or from battery pack power, as long as the battery pack has been fully charged as described in Paragraph 2-6.
- 3) Zero the instrument as described in Paragraph 2-14.

WARNING

 Some procedures require the use of high voltage. Take care to prevent contact with live circuits which could cause electrical shock resulting in injury or death.

b. DC Volts Checkout.

- 1) Select dc voltage readings with the AC/DC and V pushbuttons.
- 2) Connect the DC Calibrator (Item A, Table 3-1) to the instrument.
- 3) Select the 200mV range, and apply positive 100 mVdc to the DMM. The reading must be within the limits specified in Table 3-2.
- 4) Select each remaining range and apply the required voltage as specified in Table 3-2, verify that the reading is within specifications.
- 5) Repeat all checks with negative voltage.

TABLE 3-2.  
DC Voltage Performance Check

Range	Applied Voltage	Allowable Readings at 18° to 28°C
200 mV	100.00 mV	99.93 to 100.07
2 V	1.0000 V	0.9995 to 1.0005
20 V	10.000 V	9.995 to 10.005
200 V	100.00 V	99.95 to 100.05
1200 V	1000.0 V	999.5 to 1000.5

c. AC Volts Checkout.

- 1) Select ac voltage readings with the AC/DC and V pushbuttons.
- 2) Connect the AC Calibrator (Item B, Table 3-1) to the DMM. Set the calibrator frequency to 1 kHz.
- 3) Set the DMM to the 200 mV range and apply 100 mV ac to the DMM. The reading must be within the limits specified in Table 3-3.
- 4) Select the 2, 20 and 200 volt ranges and apply the required voltages as specified in Table 3-3. Verify that the readings are within specifications.

5) To check the 1000 volt range, connect the AC Calibrator Amplifier (Item C, Table 3-1) to the output of the AC Calibrator per the manufacturer's instructions. Set it for an output of 1000 volts ac rms and verify that the DMM readings is within the specified limits.

TABLE 3-3.  
 AC Voltage Performance Check

Range	Applied Voltage	Allowable Readings at 18° to 28°C
200 mV	100.00 mV	99.15 to 100.85 mV
2 V	1.0000 V	0.9925 to 1.0075 V
20 V	10.000 V	9.935 to 10.065 V
200 V	100.00 V	99.35 to 100.65 V
1000 V	1000.0 V	993.5 to 1006.5 V

d. Resistance Checkout.

- 1) Select resistance readings by pressing the  $\Omega$  pushbutton.
- 2) Set the HI/LO pushbutton to HI and select the 20k  $\Omega$  range.
- 3) Connect the decade resistor (Item D, Table 3-1) to the DMM.
- 4) Set the decade resistor to zero and measure the resistance of the test leads. Subtract this reading from the displayed reading in all of the following steps.
- 5) Set the decade resistor to 19.000 k $\Omega$ . Verify that the reading is within the limits specified in Table 3-4.
- 6) Select the next range and measure the next resistance as specified in Table 3-4. Verify that each reading is within specifications. Test each item in the table, switching the HI/LO pushbutton as indicated.

TABLE 3-4.  
 Resistance Performance Check

HI/LO	Range	Resistance	Allowable Reading at 18° to 28°C
HI	20 k $\Omega$	19.000 k $\Omega$	18.990 to 19.010 k $\Omega$
HI	200 k $\Omega$	190.00 k $\Omega$	189.90 to 190.10 k $\Omega$
HI	2000 k $\Omega$	1.9000 M $\Omega$	1899.0 to 1901.0 k $\Omega$
HI	20 M $\Omega$	19.000 M $\Omega$	18.980 to 19.020 M $\Omega$
LO	2 k $\Omega$	1.9000 k $\Omega$	1.8957 to 1.9043 k $\Omega$
LO	20 k $\Omega$	19.000 k $\Omega$	18.957 to 19.043 k $\Omega$
LO	200 k $\Omega$	190.00 k $\Omega$	189.57 to 190.43 k $\Omega$
LO	2000 k $\Omega$	1900.0 k $\Omega$	1895.7 to 1904.3 k $\Omega$

e. DC Current Checkout:

- 1) Select dc current readings with the AC/DC and A pushbuttons.
- 2) Connect the dc current source (Item E, Table 3-1) to the DMM.
- 3) Select the 200  $\mu$ A range and apply a current of 100.00  $\mu$ A to the DMM. The reading must be within the limits in Table 3-5.
- 4) Select each range and apply the required current as specified in Table 3-5. Verify that the reading is within specifications.

f. Analysis. If the instrument is out of specified limits at any point in Tables 3-2 through 3-5, calibrate the DMM as described in Section 4. If the unit is still under warranty, refer to the note in Paragraph 3-1.

TABLE 3-5.  
 DC Current Performance Check

Range	Applied Current	Allowable Reading at 18° to 28°C
200 $\mu$ A	100.00 $\mu$ A	99.78 to 100.22 $\mu$ A
2 mA	1.0000 mA	0.9788 to 1.0022 mA
20 mA	10.000 mA	9.978 to 10.022 mA
200 mA	100.00 mA	99.78 to 100.22 mA
2000 mA	1000.0 mA	997.8 to 1002.2 mA
20 A	10.000 A	9.948 to 10.052 A



