

KEITHLEY MODEL 178 DMM OPERATOR'S MANUAL



SPECIFICATIONS

DC VOLTAGE

| RANGE | MAXIMUM READING | ACCURACY (12 months) 18°-28°C ±(% rdg + digits) | MAXIMUM ALLOWABLE INPUT |
|-------|-----------------|---|-------------------------|
| 2V | 1.9999 | 0.04% + 1d | 1200V momentary |
| 20V | 19.999 | 0.04% + 1d | 1200V |
| 200V | 199.99 | 0.04% + 1d | 1200V |
| 1200V | 1200.0 | 0.04% + 1d | 1200V |

Temperature Coefficient (0°-18° and 28°-55°C):
±(0.006% + 0.2 digit)/°C

Input Resistance: 10MΩ ±0.1%

Settling Time: 1 second to within 1 digit of final reading.

Normal Mode Rejection Ratio:

Greater than 60dB at 50Hz and 60Hz.

Common Mode Rejection Ratio (1kΩ unbalance):

Greater than 120dB at DC, 50Hz and 60Hz.

AC VOLTAGE

| RANGE | MAXIMUM READING | ACCURACY (12 months) (above 2000 counts) 18°-28°C; 100Hz-10kHz ±(% rdg + digits) | TEMPERATURE COEFFICIENT 0°-18° and 28°-55°C ±(% rdg + digits)/°C | |
|-------|-----------------|---|--|--------------|
| | | | 45Hz-10kHz | 10kHz-20kHz |
| 2V | 1.9999 | 0.4% + 15d | 0.04% + 0.5d | 0.09% + 0.5d |
| 20V | 19.999 | 0.3% + 15d | 0.01% + 0.5d | 0.03% + 0.5d |
| 200V | 199.99 | 0.3% + 15d | 0.01% + 0.5d | 0.03% + 0.5d |
| 1000V | 1000.0 | 0.3% + 15d | 0.01% + 0.5d | 0.03% + 0.5d |

Extended Frequency Accuracy:

(45Hz-100Hz) ±(0.5% + 15 digits)
(10kHz-20kHz) ±(1.0% + 15 digits)

Response: Average responding calibrated in rms of a sine wave.

Settling Time: 2.5 seconds to within 10 digits of final reading.

Input Impedance:

1MΩ ±1% shunted by less than 75pF.

Maximum Allowable Input Voltage:

1000V rms, 1400V peak, 10⁷V·Hz maximum.

Common Mode Rejection Ratio (1kΩ unbalance):

60dB at DC, 50Hz and 60Hz.

RESISTANCE

| RANGE | MAXIMUM READING | ACCURACY (12 months) 18°-28°C ±(% rdg + digits) | TEMPERATURE COEFFICIENT 0°-18° and 28°-55°C ±(% rdg + digits)/°C | NOMINAL APPLIED CURRENT |
|--------|-----------------|---|--|-------------------------|
| 2kΩ | 1.9999 | 0.04% + 2d | 0.003% + 0.2d | 1mA |
| 20kΩ | 19.999 | 0.04% + 1d | 0.003% + 0.2d | 100μA |
| 200kΩ | 199.99 | 0.04% + 1d | 0.003% + 0.2d | 10μA |
| 2000kΩ | 1999.9 | 0.04% + 1d | 0.003% + 0.2d | 1μA |
| 20MΩ | 19.999 | 0.10% + 1d | 0.02% + 0.2d | 0.1μA |

Maximum Allowable Input: 250V rms sine, 350V peak.
Maximum Voltage Across Unknown: 2V within range, 5V open circuit.

Settling Time: 1 second to within 1 digit of final reading except 2 seconds on the 20MΩ range.

GENERAL

DISPLAY: Five 0.5" LED digits, appropriate decimal position and polarity indication.

CONVERSION PERIOD: 400 milliseconds.

ENVIRONMENT:

Operating: 0°C to 55°C;

0% to 80% relative humidity up to 40°C.

Storage: -25°C to +65°C.

POWER: 105-125 or 210-250 volts (switch selected), 90-110V available. 50-60Hz, 7 watts.

Optional 6 hour battery pack, Model 1788.

DIMENSIONS, WEIGHT: 85mm high x 235mm wide x 275mm deep (3-1/2 in. x 9-1/4 in. x 10-3/4 in.). Net weight: 1.7kg (3lbs., 13 oz).

OVERRANGE INDICATION: Display blinks all zeros above 19999 counts.

MAXIMUM COMMON MODE VOLTAGE: 1400V peak.

INITIAL PREPARATION

SAFETY CONSIDERATIONS

When the DMM is line operated, be sure the "third wire" ground on the power cord is connected to earth ground.

POWER

The DMM can be powered by line voltage or by the optional Model 1788 Rechargeable Battery Pack. Refer to the illustration of the Rear Panel for the following discussion.

- ① Set the Line Switch as shown in the illustration.
CAUTION: Connect only to the line voltage specified. Incorrect line voltage may damage the DMM.
- ② Connect the power cord. The power cord is permanently attached and is conveniently stored by wrapping around the plastic feet and inserting plug end into one of two slots in rear bottom panel.

This adjustment is used only for Calibration. It is not intended for adjustment during operation.

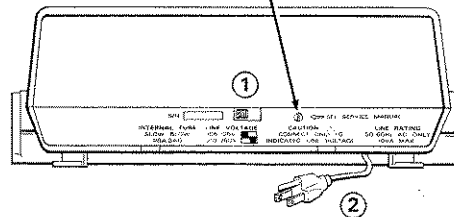

HOW TO REMOVE THE COVER

To gain access to the internal circuit board for installation of the Model 1788 Battery Pack, proceed as follows:

1. Unplug the power cord from line power.
2. Turn the DMM bottom side up.
3. Loosen and remove the slotted screws in 4 holes on the bottom panel.
4. Hold the top and bottom covers together to avoid their separation and turn the DMM over to normal position.
5. Lift off the top cover.
6. To install the top cover again, reverse the procedure.
7. Take care that the four brown plastic spacers that support the Calibration Shield are not disturbed. The spacers are used to support the Model 1788 Battery Pack, when installed, instead of the Calibration Shield.

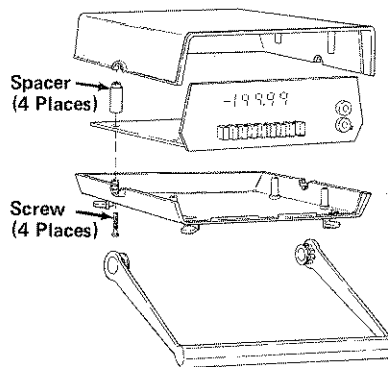

HOW TO INSTALL THE MODEL 1788

1. Disconnect the power cord and set power to OFF.
2. Remove the top cover.
3. Lift off the Calibration Shield that is supported by 4 brown plastic spacers. Save the Calibration Shield since it is necessary for proper calibration of the DMM.
4. Set the BAT/LINE switch on the DMM circuit board to the BAT position. Note that if the switch is not set to BAT, the Model 1788 will not function properly.
5. Remove fuse F301 on the Battery Pack.
6. Place the Model 1788 on the brown plastic spacers as shown.
7. Ground clip must make contact with upper side of base of Battery Pack.
8. Plug in the connector from the Model 1788 at location P1004 on the DMM circuit board. Make sure the connector is aligned so that all pins mate properly, otherwise damage to the DMM will result.
9. Install fuse F301 in Battery Pack.
10. Replace the DMM top cover.
11. Reassemble the DMM as described in Cover Removal.
12. Charge the Model 1788.

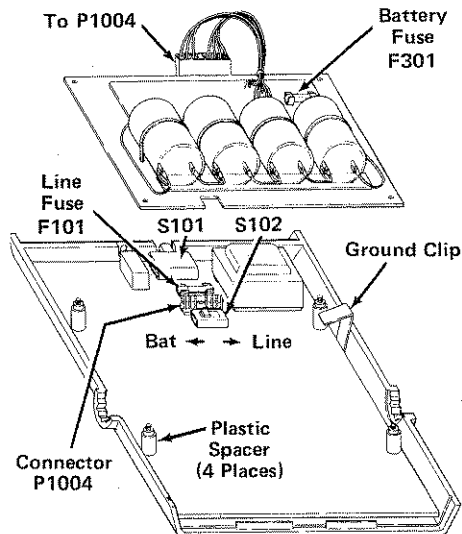

HOW TO CHARGE THE MODEL 1788

1. Connect the power cord
2. Set DMM power to OFF.
3. Allow the Model 1788 to charge for at least 14 hours.

IMPORTANT

When the DMM is set to power OFF, the charge rate is maximum. When the DMM is set to power ON, the charge rate is reduced to a trickle charge. For maximum battery life, never leave the Model 1788 in discharged condition.

OPERATING INSTRUCTIONS

POLARITY (NEGATIVE IS INDICATED, POSITIVE IS IMPLIED WHEN MINUS (-) DISPLAY IS OFF)

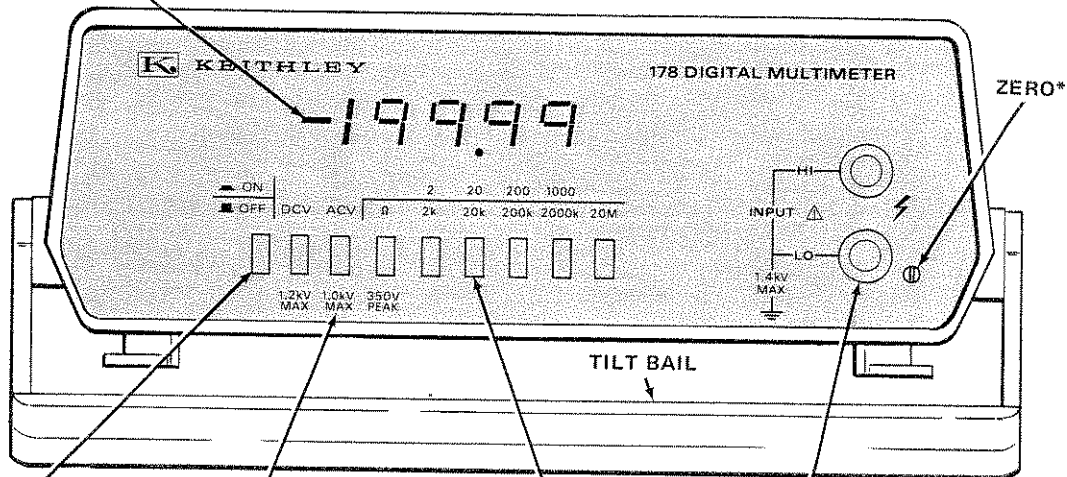

- 1 SET POWER ON
- 2 SELECT FUNCTION
- 3 SELECT RANGE
- 4 CONNECT SOURCE

* NOTE: See zero control on second page of Operating Instructions.

1 TO OPERATE FROM LINE POWER:

- Set the Line Switch as described in INITIAL PREPARATION.
- Connect the power cord to line power.
- Set power to ON.

TO OPERATE FROM BATTERY POWER:

- Install the Model 1788 as described in INITIAL PREPARATION.
- Charge the Model 1788.
- Disconnect the power cord.
- Set power to ON.

2 FUNCTION AND RANGE SELECTION: The pushbuttons are interlocked to avoid improper settings.

- 3 **DCV and ACV:** Four ranges are available. The maximum reading is 19999. Overrange is indicated by a flashing 0000 except on the 1000 volts range. Care should be taken not to exceed the maximum ratings. On DCV, polarity is displayed automatically and a positive display is implied when the minus display is off.

Ω (OHMS): Five ranges are available. The maximum reading is 19999. Overrange is indicated by a flashing 0000. Care should be taken not to exceed the maximum ratings. The engineering units refer to kilohms (k) or megohms (M).

The HI terminal is positive and causes forward conduction of semiconductor junctions. Two volts is applied at full range with 5 volts under open circuit conditions.

- 4 **INPUT CONNECTIONS:** Use the Model 1681, 1683 or other appropriate banana jack test leads.

OPERATING INSTRUCTIONS

MAXIMUM RATINGS:

- DCV:** (2V): 450V rms continuous; 1200V peak, for 8 seconds per minute.
(20-1200V): 1200V peak.
- ACV:** (All Ranges): 1000V rms; 10^7 V·Hz.
- Ω:** (All Ranges): 250V rms continuous or 350V peak.

***ZERO CONTROL:** The zero nulls input offset on 20, 200, 1200 DCV ranges, and all Ω ranges. Typically, the control may not need adjustment more often than once per week except for environmental conditions outside of the 18°C to 28°C temperature range, or for lead compensation on Ω function. To assure rated accuracy on DCV and Ω range, set the DMM to 20V DC, short the input, and adjust **ZERO** for 0000.

MODEL 1788 RECHARGEABLE BATTERY PACK: The Model 1788 is a field-installed rechargeable battery pack that operates the DMM 6 hours from fully charged batteries. The Model 1788 recharges completely in 14 hours using the built-in charging circuit. Refer to INITIAL PREPARATION for installation instructions.

- To charge the Model 1788:
1. Connect the power cord.
 2. Set DMM power to **OFF**.
 3. Allow the Model 1788 to charge for at least 14 hours.

IMPORTANT

When the DMM is set to power **OFF**, the charge rate is maximum. When the DMM is set to power **ON**, the charge rate is reduced to a trickle charge. For maximum battery life, never leave the Model 1788 in discharged condition.

CALIBRATION AND SERVICING: Calibration and servicing should be performed only by qualified service personnel. Brief calibration instructions are furnished on the internal Calibration Shield. Complete calibration and servicing information is available in the accessory Model 1785 Service Manual.

- LINE FUSE RATING:** 1/8A, 250V, 3AG, SLOW-BLOW (internally installed)
BATTERY FUSE RATING: 2A, 3AG, FAST-BLOW (installed on Model 1788)

WARRANTY

We warrant each of our products to be free from defects in material and workmanship. Our obligation under this warranty is to repair or replace any instrument or part thereof, which within a year after shipment, proves defective upon examination. We will pay local domestic surface freight costs.

SERVICE POLICY

For service on your Model 178 or 179 DMM, contact your local representative who will be able to give you immediate assistance in most cases. Complete repair and calibration facilities are maintained in Cleveland, Ohio; Munich, West Germany and Reading, United Kingdom, as well as first line repair service in Palaiseau, France. Information concerning the application, operation or service of your instrument may be directed to the applications engineer at any of the above locations.

Keithley Instruments, Inc., 28775 Aurora Road, Cleveland, Ohio 44139. (216) 248-0400
European Headquarters: Heighofstrasse 5, D-8000 Munchen 70 West Germany, (089) 7144065
United Kingdom: 1 Boulton Road, Reading, Berkshire, (0734) 861287
France: 44 Rue Anatole France, F-91121 Palaiseau (01) 928-00-48

ACCESSORIES

Model 1600 High Voltage Probe

The Model 1600 extends the DMM to 40kV. It has a 1000:1 division ratio which means that 1 volt on the DMM corresponds to 1 kilovolt.

To Operate: Set the DMM to DCV and appropriate range. Connect the banana plug on the Model 1600 to the INPUT terminals. Connect the alligator clip on the Model 1600 to source low. Connect the probe tip to source high.

Specifications:

Voltage Range: 0 to 40,000 volts DC.

Input Resistance: 1000 megohms.

Division Ratio: 1000:1.

Ratio Accuracy

±1.5% at 25kV, decreasing to

±2.0% at 20kV and 30kV

±3.0% at 10kV and 40kV, and

±4.0% at 1kV.

Ratio Stability: ±0.01% per °C; ±0.1% per year.

Heating Effects: Self-heating due to application of high voltage for period in excess of 1 minute will cause a maximum of 0.2% additional error at 40kV (error is less at lower voltage).

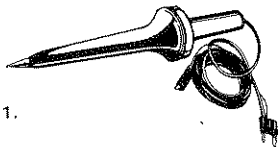

Model 1651 50-Ampere Shunt

The Model 1651 allows current measurements to be made up to 50 amperes. It is a 0.001 ohm ±1% 4-terminal shunt. When the DMM is set to the 2 volt range, a fifty ampere current will correspond to 50 millivolts (.0500 volts).

To Operate: Connect separate current leads (not furnished) between the source and the Model 1651 hex-head bolts. Use leads that are rated up to 50 ampere capacity. Connect the voltage leads (furnished) between the Model 1651 screw terminals and the DMM INPUT terminals. Set the DMM to ACV or DCV and 200mV range.



Model 1681 Clip-On Test Lead Set

The Model 1681 contains two leads, 1,2m (48 inches) long, terminated with banana plug and spring-action clip-on probe.

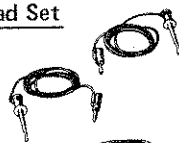

Model 1682 RF Probe

The Model 1682 extends the AC voltage response of the Model 178 from 20kHz to 100MHz.

To Operate: Set the DMM to DCV and appropriate range. Connect the Model 1682 to the DMM INPUT terminals.

Specifications:

Voltage Range: 0.25 to 30 volts rms.

Transfer Accuracy: ±0.5dB, 100kHz to 100MHz peak responding calibrated in rms of a sine wave.

Input Impedance: 4 megohm shunted by 3pF.
Maximum Allowable Input: 30V rms AC, 200V DC.
Accessories Supplied: straight tip, hook tip, ground clip, hi adapter, banana plug adapter.



Model 1683 Universal Test Lead Kit

Two test leads, 1.2m (48 inches) long with 12 screw-in tips - 2 banana plugs, 2 spade lugs, 2 alligator clips with boots, 2 needle tips with chucks and 4 heavy duty tip plugs.

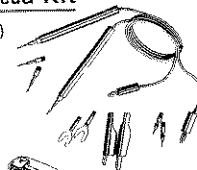

Model 1684 Carrying Case

The Model 1684 is a hard vinyl case with a fitted foam insert with room for the Service Manual and small accessories.

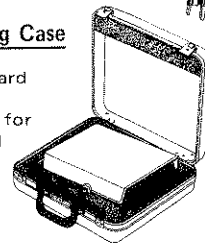

Model 1685 Clamp-On AC Current Probe

The Model 1685 measures AC current by clamping onto a single conductor. Interruption of the current path is unnecessary. The Model 1685 detects current by sensing magnetic field produced by current.

To Operate: Set the DMM to ACV and appropriate range. Connect the Model 1685 to the DMM INPUT terminals. The DMM will display 0.1 volts rms per ampere.

Specifications:

Range: 2, 20 and 200 amperes rms.

Accuracy: ±4% of range at 60Hz. ±6% of range at 50Hz.

Temperature Coefficient: ±0.05%/°C on the 20 and 200 ampere ranges. ±0.3%/°C on the 2 ampere range.

Maximum Allowable Current: 300 amperes rms.

Maximum Conductor Voltage: 600 volts rms.

Conversion Ratio: 0.1 volt rms per ampere.

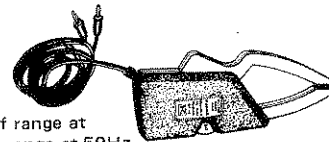

Model 1010 Single Rack Mounting Kit

The Model 1010 is a single rack mounting kit with overall dimensions 5-1/4 inches (133mm) high and 19 inches (483mm) wide.



Model 1017 Dual Rack Mounting Kit

The Model 1017 is a single/dual mounting kit with overall dimensions 5-1/4 inches (133mm) high and 19 inches (483mm) wide.

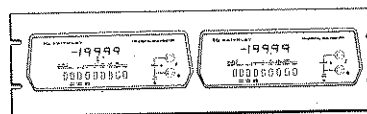

Model 1785 Service Manual

The Model 1785 is a complete, illustrated Operating and Service Manual. It includes Theory, Troubleshooting, Calibration, Parts List and Schematic.

