

Tunable Grating Filter

The JDS Uniphase Tunable Grating Filter is designed for high-performance laboratory and production testing of single-mode fiber-based components and subsystems. It features fine adjustment with resolution of 0.01 nm, and narrow passbands are available from 0.22-1.4 nm. The filter attains much higher wavelength isolation roll-off than Fabry-Perot etalons or interference filters.

The filter can be used for amplified spontaneous emission (ASE) filtering in erbium-doped fiber amplifier (EDFA) applications or to remove spontaneous emission from distributed feedback lasers (DFBs) and tunable lasers in measurements of wavelength selective components.

Both single and double pass grating configurations are available to provide high rejection and narrow bandwidth.

Six standard models are available with different bandwidths and optical performance for specific applications. The Tunable Grating Filters can be controlled from the front panel keypad or by the GPIB and RS232 interfaces.



Key Features & Benefits

Grating-based optical filter

*Full width at half maximum (FWHM)
as low as 0.22 nm*

High rejection

Single-mode fiber in and out

Parallel and serial interfaces

GPIB and RS232 remote control

*Complies to CE requirements plus UL3101-1
and CAN/CSA-C22.2 No. 1010.1*

Applications

Spontaneous emission suppression

Tunable laser based testing

ASE filtering in EDFAs

WDM and DWDM component testing

Specifications

MODEL	226	166	223	126	116	106
Tuning range	1530-1570 nm ¹ 1525-1625 nm ²	yes yes	yes yes	yes yes	yes yes	yes yes
- 3 dB bandwidth (± 15 %)	0.22 nm	0.25 nm	0.55 nm	0.55 nm	1.1 nm	1.4 nm
- 20 dB bandwidth (± 15 %)	0.6 nm	0.7 nm	1.5 nm	1.5 nm	3.0 nm	4.0 nm
Insertion loss	1530-1570 nm 1525-1625 nm	≤ 6.0 dB ≤ 7.0 dB	≤ 4.0 dB ≤ 4.0 dB	≤ 5.5 dB ≤ 7.0 dB	≤ 3.0 dB ≤ 3.0 dB	≤ 3.0 dB ≤ 3.0 dB
Polarization dependent loss	1530-1570 nm 1525-1625 nm	≤ 0.2 dB ≤ 0.5 dB	≤ 0.6 dB ≤ 0.6 dB	≤ 0.2 dB ≤ 0.5 dB	≤ 0.6 dB ≤ 0.6 dB	≤ 0.6 dB ≤ 0.6 dB
Maximum input power	standard high power	300 mW 1 W	300 mW 1 W	300 mW 1 W	300 mW NA	300 mW NA
Resolution	0.01 nm					
Return loss	> 45 dB					
Repeatability	0.05 nm					
Accuracy ³	± 0.2 nm					
Input voltage	100-240 V AC, 50-60 Hz					
Power consumption	80 VA maximum					
Dimensions W x H x D	21.2 x 8.9 x 35.5 cm/19 inch, 2U high, half-rack width					
Weight	4 kg					
Operating temperature	10 to 40 °C					
Storage temperature	0 to 50 °C					
Humidity	maximum 95 % RH up to 40 °C, non condensing					
Calibration period	1 year					

1. Can be used over the 1460-1575 nm wavelength range.
2. Can be used over the 1500-1625 nm wavelength range.
3. Specifications are valid after 1 hour of warm-up.

Sample Order: TB90116+22FA1

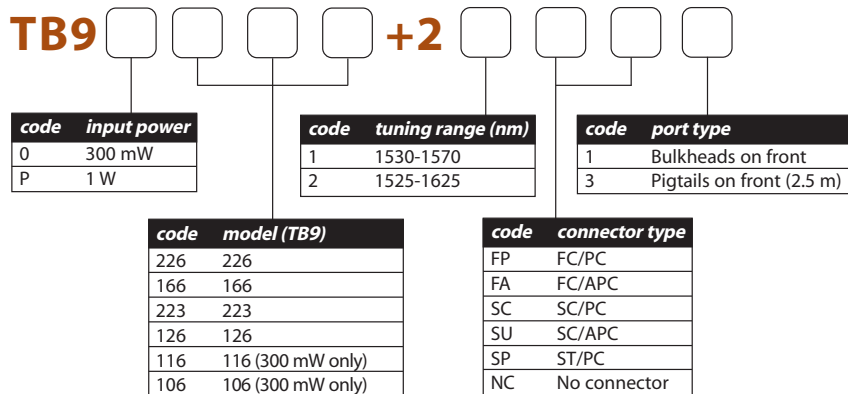

Indicate your requirements by selecting one option from each configuration table. Print the corresponding codes in the available boxes to form your part number.



If the configurations available do not meet your performance requirements, please contact our global sales and customer service team to discuss the potential for specialized solutions.

ST is a registered trademark of Lucent Technologies.

All statements, technical information and recommendations related to the products herein are based upon information believed to be reliable or accurate. However, the accuracy or completeness thereof is not guaranteed, and no responsibility is assumed for any inaccuracies. The user assumes all risks and liability whatsoever in connection with the use of a product or its application. JDS Uniphase reserves the right to change at any time without notice the design, specifications, function, fit or form of its products described herein, including withdrawal at any time of a product offered for sale herein. JDS Uniphase makes no representations that the products herein are free from any intellectual property claims of others. Please contact JDS Uniphase for more information. JDS Uniphase, the JDS Uniphase logo and the JDS Uniphase Instrumentation logo are trademarks of JDS Uniphase Corporation. Other trademarks are the property of their respective holders. 2003 © JDS Uniphase Corporation. All rights reserved. Printed in Canada. **10109639 Rev.002 09/03**

INSTRUMENTATION TECHNICAL SUPPORT

1.800.406.9559 (North America)
+800.406.95599 (Outside North America)
10.800.140.5599 (China)
instruments@jdsu.com

JDS Uniphase
Instrumentation