

DSAM-6000

Digital Service Analysis Meter

2007

FROST & SULLIVAN

 Global Communications
 Test & Measurement
 Company of the Year Award

Key Features

- Sweep, digital video, analog video, DOCSIS® IP, and PacketCable™ VoIP test available in one meter
- Manages and displays sweep files via the web using immediate data synchronized over DOCSIS RF
- Full 4 to 1000 MHz frequency range
- Forward sweep option allows sweeping of analog, digital, and DOCSIS carriers
- Compatibility with existing JDSU Stealth Sweep™ Systems, assuring non-interfering forward and reverse sweep operation compatible with today's digital carriers
- New Digital Quality Index™ (DQI) provides an easy to understand real time digital quality history (90 seconds)
- Rugged, lightweight design withstands rain, cold, heat, bumps, drops, and other accidental mishaps

Network maintenance is a critical element in achieving the quality of service (QoS) necessary for cable operators to compete with alternative communications providers.

One core requirement of any cable network maintenance plan is to ensure that a system's broadband frequency response in both the forward path (downstream) and the return path (upstream) performs as required.

JDSU has a long history of integrating the high-level functions and advanced technology necessary for maintaining cable networks into scalable hardware and software platforms. Coupling the innovative Signal Analysis Meter (SAM) with award-winning Stealth Sweep technology (Patent No. 5,585,842), JDSU delivers sweep meter solutions unequalled in their ability to perform advanced tests and measurements. These capabilities were integrated into the SDA-5000 series of products, which soon earned its current industry-lead position.

JDSU introduced the DSAM (Digital Service Activation Meter) when DOCSIS standards pushed the industry to adopt a common technology for delivering flawless high-speed data and IP services. This award-winning, landmark meter integrated JDSU's well-known Service Analysis Meter (SAM) functions with DOCSIS cable modem and PacketCable multimedia terminal adapter (MTA) elements and a PC-based management and file system.

Now, JDSU has introduced the next Wavetek™ Field Meter, the DSAM-6000 Digital Services Analysis Meter. Recognizing that maintaining cable networks requires more than sweep, JDSU combined the DSAM's video, audio, and data test functions with the SDA's downstream forward path and upstream return path sweep functions and created a rugged, multitechnology handheld that performs in the harshest environments.

Because it uses the SDA's powerful Stealth Sweep technology, the DSAM-6000 can be used with existing SDA rackmounted sweep gear, SDA-5500 and SDA-5510, located at headend and hub sites. Additionally, the DSAM-6000 meters can sweep side-by-side with SDA-5000 meters. Therefore, major modifications are not required when DSAM-6000 meters are added to a department's pool of meters.

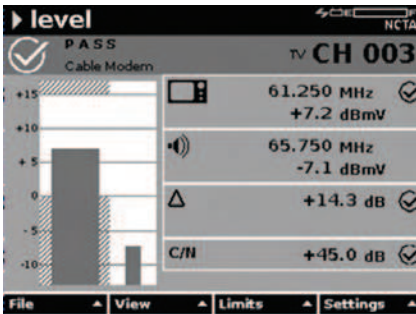

Level mode on an analog channel displays video and audio signal levels and their delta value. Carrier-to-Noise (C/N) ratio is also displayed.

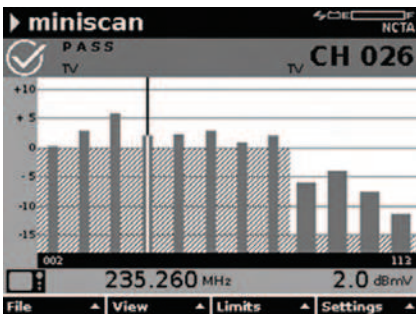

Miniscan measures signal strength of up to 12 channels simultaneously.

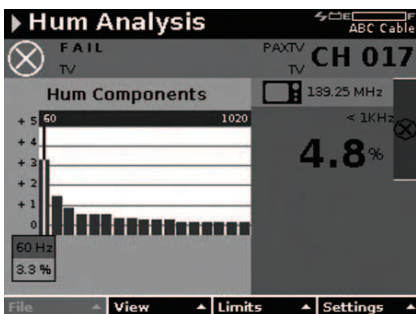

Undesired electrical interference can appear on a video channel as one or two horizontal bars. A Hum measurement reveals if any electrical interference is present on tested channel.

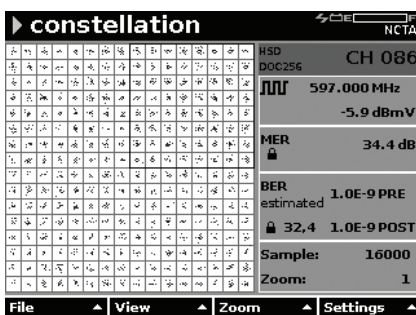

A Constellation graph shows impairments on the network with patterns in the display. By identifying the pattern technicians can figure out what is the probable cause of the impairment.

Features

Signal Level Meter (SLM)

Traditional SLM test functions for analog video and audio levels as well as JDSU's extremely accurate digiCheck™ digital power level measurements are supported by the DSAM-6000. Furthermore, the ability to measure carrier-to-noise (C/N) on analog carriers comes standard. The DSAM-6000 can measure downstream carriers to a full 1GHz and analyze 64, 128 and 256 QAM, including deep interleave (i=128, j=4) modulation. Also included are MER and pre- and post-FEC BER on both digital video and DOCSIS carriers, allowing technicians to validate that digital services are received and they meet adequate margin and quality specifications.

Miniscan and Full Scan Modes

When measuring analog and digital as well as DOCSIS signals, technicians can see high- and low-frequency channels and verify how much level headroom remains when limits are activated. In miniscan mode, the DSAM monitors up to 12 channels at a time and in full scan mode it monitors the entire channel plan, up to 999 channels. The results of both scans are displayed either as an easy-to-see bar graph or in an informative table.

Tilt Mode

Tilt mode is used while sweeping to check the forward tilt of the channel levels at the low and high ends of the frequency spectrum. The variances of the levels, which are displayed at the bottom of the DSAM-6000 screen, indicate distortion of the frequency spectrum. Based on these results, technicians know which equalizer pad to select that will provide optimum flatness at the end of the line.

Hum Analysis Mode

A hum measurement may be performed on a nonscrambled analog channel. Since the instrument is battery powered, the measurement is independent of ground loops and therefore is isolated from the line (mains). Severe hum is revealed on a TV as either single (60/50 Hz) or double (120/100 Hz) horizontal bars across the video screen. The DSAM-6000 hum display indicates the composite level of all frequency components below 1000 Hz as well as the fundamental hum frequency. The lower levels of adjacent frequencies as well as the fundamental are displayed across a frequency graph. This is valuable in determining the source of hum generation by displaying a telltale signature of the source (patent pending).

Constellation Mode

There are various elements in a network that compromise video quality. The DSAM-6000 constellation mode displays patterns of data points on a graph, which are easily interpreted, enabling technicians to detect and quickly diagnose the source of digital video problems.

3

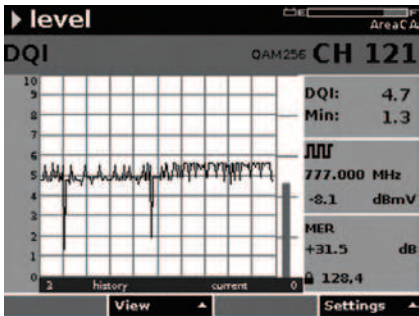

DQI will display intermittent, short duration impairments missed by MER and BER as well as steady state issues typically captured by MER and BER.

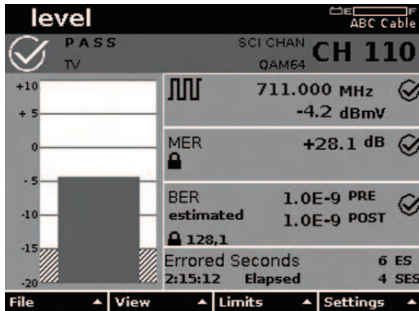

In the level mode on a digital channel, the signal's level and MER are measured and the channel's BER and errored seconds are tracked.

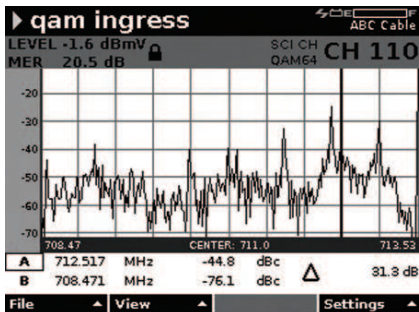

QAM Ingress test allows the technician to see what is going on underneath a live digital carrier which is usually not viewable due to the presence of the "haystack".

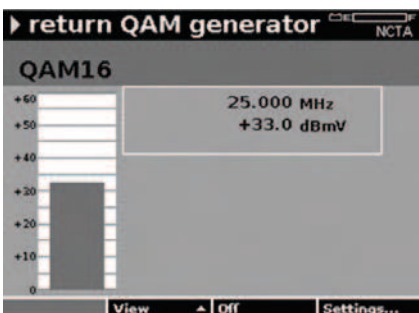

The Return QAM Generator enables operators to test and prove upstream network performance.

Digital Quality Index™ (DQI) Mode

DQI is an indicator of the overall health of a QAM stream. This measurement does a great job tracking intermittent problems and is unique only to JDSU. It is represented by an easy to understand Index rating from "1" to "10" with ten being the highest quality. DQI also catches errors sometimes missed by BER and Errored Seconds measurements. It also displays a 90 second graphical history.

MER Mode

Modulation error ratio (MER) is the earliest indication of transmission quality degradation resulting from noise, ingress, and composite distortions. An expression of signal-to-noise ratio plus all other non-transient distortion signals, MER also shows phase and amplitude distortions that may have been passed from the headend. MER is the best overall quality measurement that can be performed on a digital QAM carrier. JDSU has perfected this valuable measurement by optimizing both custom hardware and proprietary software algorithms (Patent Nos. 6,061,393; 6,233,274; 6,278,730 and 6,385,237). The result is accurate readings that far exceed those reported from customer premise equipment such as digital settops.

BER Mode

Bit error ratio (BER) helps to quickly detect impulse changes in the system by revealing when information is lost or corrupted at the bit layer. The DSAM-6000 measures BER by tracking the number of errored bits that are seen before forward error correction (FEC), known as pre-BER, and the number of bits that cannot be fixed by FEC, known as post-BER.

Errored Seconds and Severely Errored Seconds Measurement

For troubleshooting connections that are suspected of intermittent bit errors, the technician needs a means of capturing the presence of errors that have occurred over a period of time. If an error has occurred during any second of elapsed time, the errored second field increments by one. One error or multiple errors in the same second is counted as one errored second. If more than 1 bit in 1 million bits has errors occurring in the same second, the severely errored second register increments by one. The errored seconds fields are conveniently included in the digital level display.

QAM Ingress Mode

Detecting the presence of ingress within the digital tier of carriers on the downstream path is nearly impossible without turning off the service. The tightly spaced QAM carriers hide any visual presence of unwanted forward ingress such as CSO and CTB. An MER test will indicate that an issue exists but with the DSAM-6000 and the patented JDSU QAM Ingress mode the technician can inspect what is actually going on beneath the digital "haystack" while still remaining in service.

Return QAM Generator

Standard on the DSAM-6000, the Return QAM Generator is a mobile 16 QAM transmitter. The ability to transmit a QAM-16 modulated signal back to the headend is helpful for proving line capabilities for future data and voice channels and for troubleshooting return path issues in the network.

Applications

Comprehensive Analog and Digital Testing on the Forward Path

The DSAM architecture incorporates analog and digital testing into a single user interface. This allows the technician to select a specific channel or a scan of channels without having to differentiate between analog or digital video, DOCSIS high-speed data, or voice.

The active channel plan functions as a meter configuration file as well as a channel lineup. An extensive selection of configuration elements establishes the type of tests that can be performed on a particular channel for each channel in the plan.

Also inherent within a given channel plan are autotest configurations for analog, digital, and DOCSIS services. Most configurations can be entered into the meter directly or through the JDSU Test Productivity Pack (TPP) client/server application software. Accessed via a PC, TPP manages channel plans and measurement files for a collection of DSAM meters.

Networks with a history of multiple ownerships and diverse hardware architectures are not a problem for the DSAM-6000. Supervisors can create multiple channel plans for a specified group of meters or one channel plan for the whole network. The channel plans can be deployed with plan parameters locked when needed. Specific plans are easily selected from Configure mode, or in many cases, directly from within a measurement mode. After selecting an active plan, a technician can check the top of the measurement screen to confirm that it is the correct plan. The channel plan name is included any saved measurement file for reference. Using the channel plan to configure an Autotest, multiple tests can be run in a short period of time with only two button presses.

Return and Forward Path Testing and Maintenance

A cable plant is a two-way path of information, enabling communication between equipment. As a vital link between the CPE and the CMTS, the return path must be aligned and kept free of ingress and noise. With digital services, limiting noise and ingress becomes even more important because their effect may not be noticed until service has significantly degraded.

The DSAM-6000 is designed to test and maintain both the downstream forward path and upstream return path. Its ability to sweep, along with conducting signal level and quality measurements; ingress testing; verifying forward path signals; and testing the level of ingress and noise provide the optimal approach to maintaining the return path.

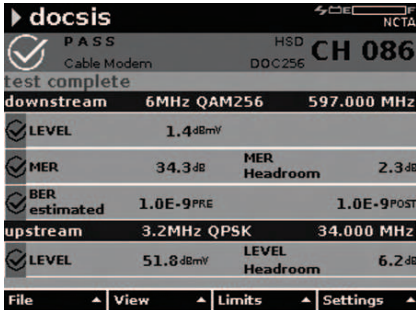

Using the range screen a technician is able to see what levels the DSAM's cable modem is reading and transmitting. This allows the tech to see how close the customer's cable modem would be to failing.

DOCSIS Service Testing

The DSAM-6000 has a built in cable modem capable of performing quick and accurate DOCSIS 2.0 RF and IP testing. This eliminates the need for a test modem to verify cable modem connectivity or a computer to test the customer premises equipments connection.

Range and Registration

The DSAM-6000 can range and register with the headend CMTS to establish the required configuration parameters and obtain a valid IP address on the network. The DSAM's range and registration test verifies that a specific portion of the line can support high-speed data transmission. Ranging results show how much margin remains before communications in both the up and down streams become disabled. Registration results validate that the CMTS is distributing correct configuration files and IP addresses.

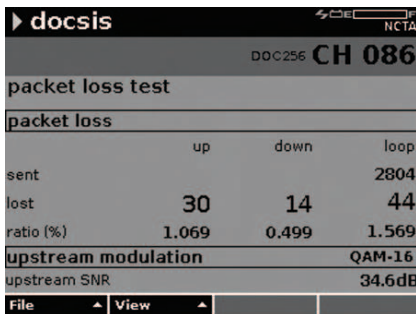

A packet loss test shows how well the HFC transmits RTP data packets. Using TruPacket SNMP community strings the DSAM is able to view both the up and down stream packet losses separately as well as the SNR the CMTS is receiving.

DOCSIS IP Test

The DSAM performs IP tests including packet loss, throughput and ping over the DOCSIS layer. The displayed results indicate which problems need to be tracked down and fixed and those that should be reported as headend or IP troubles.

6

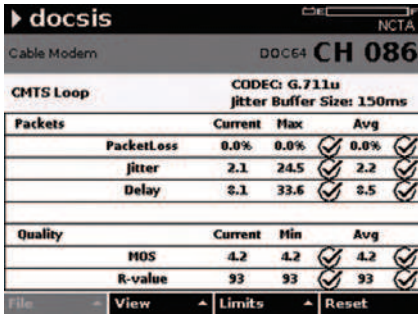

VoIPCheck displays packet loss, jitter and delay as well as MOS and R-values.

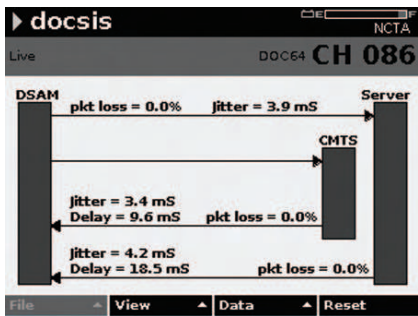

VoIPCheck is a voice quality verification test that runs over the DSAM's cable modem DOCSIS connection. It allows for segmentation between HFC and IP issues by showing on which side of the CMTS data impairments are present.

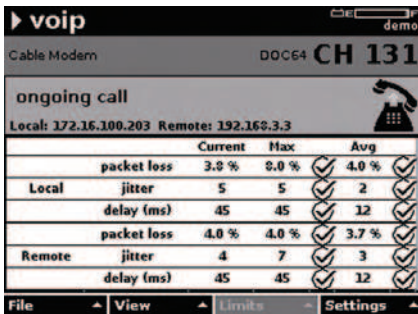

Key statistics may be monitored on live telephone calls using the TruVoice VoIP Option.

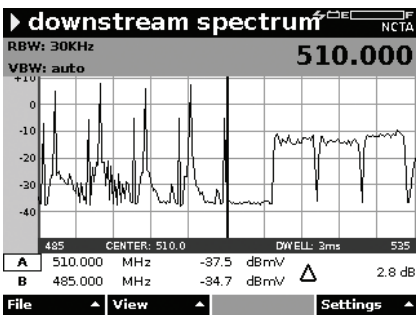

Voice Over IP (VoIP) Testing

The DSAM-6000 offers two tiers of VoIP testing options and a range of VoIP troubleshooting tools. One VoIP test enables services to be validated over a DOCSIS connection (VoIPCheck™ Option). The other on networks that have deployed PacketCable VoIP (TruVoice™ VoIP Option). The DSAM with its built-in eMTA, can place calls as if they were from the CPE. This allows technicians to fully test the VoIP registration process and verify dial tones from the network.

VoIPCheck Option

With VoIPCheck, the DSAM-6000 can test VoIP services independent of the VoIP specification being used. VoIPCheck can segment RF issues from IP issues, helping to eliminate organizational finger pointing. Packet statistics, including packet loss, jitter, and delay, as well as call-quality results such as R-value and MOS, are displayed on the screen. With its in-depth results analysis capability, the DSAM-6000 can determine the source of call-quality problems, expediting the troubleshooting process.

TruVoice VoIP Option

TruVoice VoIP enables the DSAM-6000 to measure packet statistics (packet loss, delay, and jitter) and call quality (R-value and MOS) while on an active phone call either placed or received with the DSAM's eMTA. Listening to the call, the technician can hear if there are any noticeable problems and review the diagnostics displayed on the DSAM's screen. The technician can call any phone number on any system and measure call-quality throughout the call's path to locate the problem source quickly and easily.

Enhanced Downstream Spectrum

Technicians need to be able to see how the network is behaving and troubleshoot whether channels have shifted, have missing carriers, or are experiencing in-channel frequency response problems. Since most technicians do not require a fully featured and expensive spectrum analyzer, the DSAM, with its enhanced downstream spectrum, can help provide a technician with an "everyday" spectrum analyzer. It allows the user to choose between two resolution bandwidths (RBW) settings, 330 KHz or 30 KHz and modify the amount of time spent measuring each frequency step, or dwell time of the analyzer, between 1 and 25 milliseconds. It also allows the user to see 4 MHz to 1 GHz, in 10 or 50 MHz steps, without switching test modes. Furthermore, if viewing the return path frequencies, the tech can turn on the internal low pass filter to eliminate noise caused by the higher frequencies, providing a cleaner upstream view.

Sweep

Service quality depends on transmitting signals with the best noise specifications and the lowest intermodulation distortion. The majority of all transmission errors, including digital, can be detected by measuring the frequency response of the network. A sweep trace reveals every physical error in the network that influences the transmitted signals. Also, since sweep results are independent of transmission methods and formats, it is the most effective and efficient method for technicians to set up the right gain versus frequency.

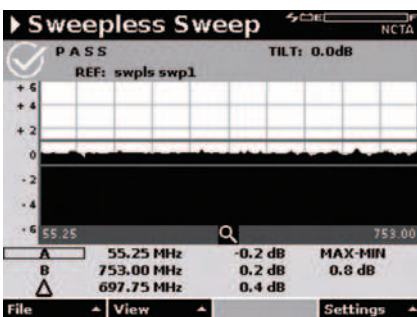
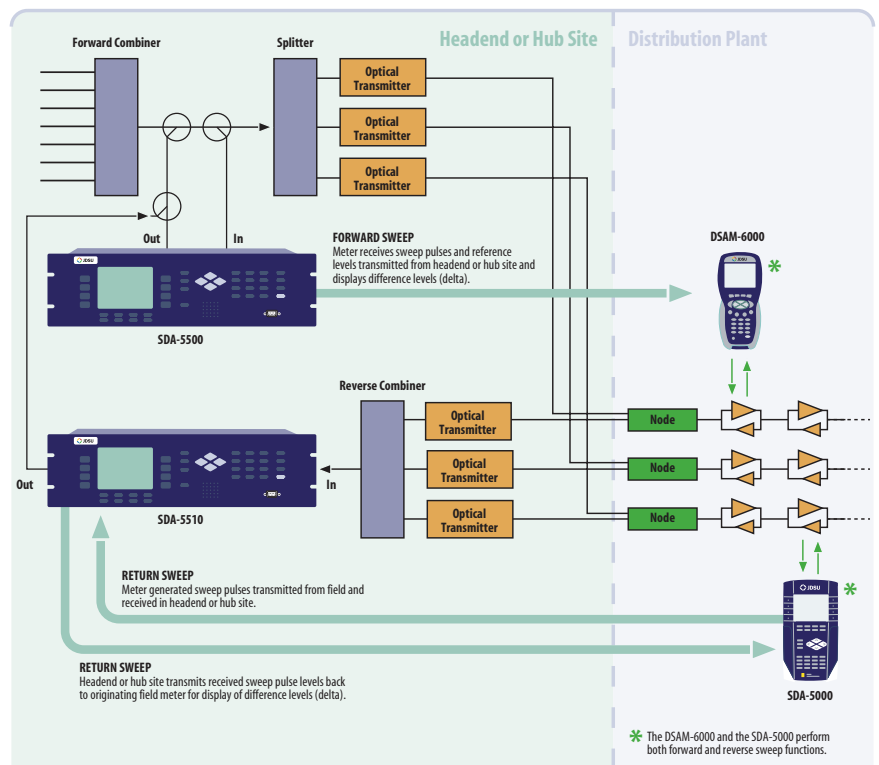

Sweepless Sweep provides a quick method to check cable system integrity using active channels to sweep the forward path. Sweep points do not need to be added and no forward path headend gear required.

Sweepless Sweep® Mode

For fundamental alignment of the forward distribution network, the JDSU Sweepless Sweep mode provides an economical solution. This mode scans the entire forward spectrum, displaying all levels across all frequencies (as defined by meter configuration). The technician adjusts the reception of the node amplifier with this scan and then normalizes the display by saving a reference. The resultant display is a flat zero level trace. When the measurement point is moved to the output of the RF amplifier, any changes due to the amplifier will be displayed as a deviation (delta) from the reference display. The same reference is used as the technician moves down the cascade, thus providing an excellent tool to align succeeding amplifiers to compensate for the effects of each cable segment. To isolate the effects of headend changes in levels, or to align portions of the spectrum where there are no active carriers to reference, the forward sweep option should be considered.

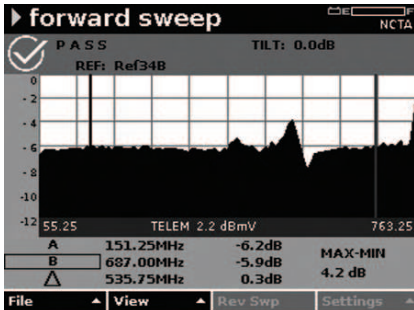

Forward sweep on the DSAM-6000 uses a unique referencing method to accurately reveal any problems in the system without interfering with any of the analog or digital carriers.

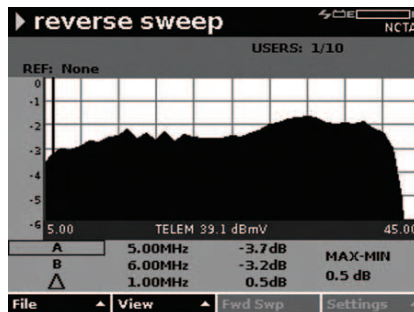

Tight reverse sweep points are setup in the sweep plan to view better resolution of the entire return path. Helping to find mismatches or other problems heading back to the headend or subsite.

Forward Sweep Option

During a forward sweep, existing video carriers (analog, digital, or scrambled) are continuously referenced, eliminating any possibility of interference to the subscriber services.

The DSAM-6000 offers fast forward sweep capabilities, especially in systems with numerous digital channels. By referencing 64, 128 and 256 QAM signal types, the DSAM-6000 removes any worries about subscriber interference and prevents sweep carriers from being injected into the guard bands. Referencing active carriers, instead of transmitting sweep signals over active carriers, allows the DSAM-6000 to sweep without degrading service quality.

Where there are absent carriers the SDA-5500 headend transceiver inserts a sweep point to fill vacant spectrum frequencies. To remove effects of headend level drift, this instrument monitors the levels and transmits new reference information with every sweep. If the signal levels change in the headend, they won't effect the sweep response measurement.

Reverse Sweep Option

The return path can be problematic for two-way communications. It should be tended to as often or more than the forward path and any impairments should promptly be fixed. One of the best procedures to preserving a clean return path is with an active reverse sweep maintenance plan. The DSAM-6000 has a built-in reverse sweep transmitter, removing the need for externally generated carriers. A reverse sweep can uncover mismatch problems, revealed as standing waves, or diplex filter roll-offs that can severely hamper the quality of services in the reverse band.

Headend Sweep Equipment

With the DSAM-6000, one person can perform forward (downstream) and reverse (upstream) path alignment simultaneously. For reverse testing with more than one field technician, the rack mounted Model SDA-5510 Headend Reverse Sweep Manager can perform reverse sweep on the same cluster of nodes for up to ten different technicians. The SDA-5500 transceiver used in conjunction with the model SDA-5510 receiver provides a full forward and reverse sweep alignment solution. The SDA-5510 can also stand alone in remote hub sites for dedicated reverse alignment applications.

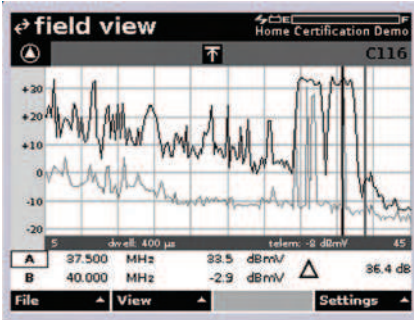

The optional Field View capability greatly improves the success rate and efficiency in locating ingress on the return path. Field technicians can view the return spectrum as received by the JDSU PathTrak Return Path Monitoring System. Both the remote spectrum and the local spectrum view can be compared on the tech's meter.

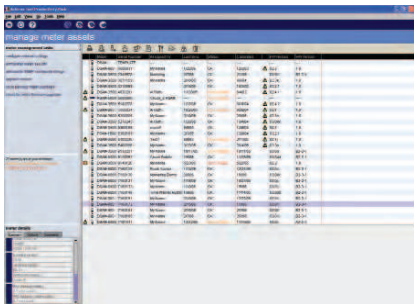

The Test Productivity Pack (TPP) lets supervisors easily configure, update, and upgrade DSAM-6000s in the field.



By synchronizing the DSAM, a technician can receive updated meter information as well as send back saved test data for historical record keeping and Home Certification tests.

Field View™ Option

Field View provides the communication between JDSU's PathTrak return path monitoring systems and field meters such as the DSAM-6000. A JDSU HSM-1000 sends spectrum measurements from PathTrak to the field meter, where the results are displayed on the DSAM's screen. By comparing local spectrum measurements to those from PathTrak, field technicians can quickly resolve return path ingress problems (Patent No. 6,425,132).

TechComplete™ Test Productivity Pack

The TechComplete Test Productivity Pack software contains the essential tools needed to efficiently process trouble tickets and manage test meter inventory and staff. Test data, limit plans, and channel plans are consolidated and stored on a central database, ensuring that the correct data is accessed and right tests are performed. The client server architecture makes it easy for field technicians to access the data remotely, review it, and use it in the field as reference for troubleshooting. Even sweep results can be uploaded for later review to track the health of the network. Roadblocks to ensuring quality of service, such as accessing incorrect channel plans and limit plans, are eliminated, which significantly decreases the number of call backs and unnecessary truck rolls. Additionally, meters can be synchronized any time they are connected to the RF plant or an active Ethernet connection.

TechComplete also helps managers communicate with their field staff. Test results can be reviewed and experienced technicians at the hub can coach less-experienced field staff with the remote DSAM feature, enabling more effective use of time and resources.

Upgrade DSAM Instruments to the DSAM-6000

Models of the DSAM-2500 and up can be upgraded to the DSAM-6000 maintenance tech meter. Any DSAM model below the DSAM-2500 must first be upgraded to the DSAM-2500 or higher before the upgrade to the DSAM-6000 can occur. All meters to be upgraded to the DSAM-6000 may be sent back to the factory for hardware upgrades or upgraded on site by authorized JDSU service personnel.

DSAM-6000 Summary Features Matrix		
Applications	Features	Included (X) or Option (O)
Analog Video	Levels, Tilt, Mini and Full Scan, C/N ¹	X
Digital Video	Ave Pwr, MER/EVM, Pre/Post FEC BER	X
	BER for Deep Interleave (128,4)	X
DS QAM Quality	Downstream Full Spectrum	X
DS Spec/Const.	Digital Quality Index™ (DQI) Score	X
	Constellation	X
Sig Gen	Return QAM Generator (16 QAM or CW)	X
Upstream Physical Verification	Upstream 2-way connectivity, level with margins	X
	US Spectrum for ingress	X
	Field View option, view of headend Upstream Spectrum	O
Modem Service Verification	MER/EVM of Downstream QAM	X
over RF	Downstream FEC BER, Rng and reg, config file, CM and CPE MAC cloning	X
IP Tests over RF and Ethernet	Roundtrip and segmented Packet Loss, US and DS throughput, Ping	X
VoIP Test	VoIPCheck DOCSIS VoIP Verification	O
	PacketCable VoIP Testing ² , includes VoIPCheck	O
Other	Web Access Test, RF and Ethernet	X
	View CM diagnostics page	X
Network RF Performance	Forward (Downstream) Sweep	O
Verification	Reverse (Upstream) Sweep	O
	Two-ports for directional test points	X
Functions		
Common Test Utilities	One Key Autotest - including scheduled proof of performance tests*	X
	Test Point Compensation	X
	Ingress Resistance Test (IRT)	X
	Fault Location using FDR feature in LST-1700 remote transmitter	X
Browser	Open Web Browser ³	O
Other	Home Certification (Closeout) Testing	O

Notes:

¹C/N functional on all DSAM models with new hardware as of DSAM-6000 start of production.

² VoIP available for North American PacketCable based on compatibility and availability for specific systems.

³ Function integrated with JDSU TPP Field Data Management Software, a client/server based PC application software used to manage DSAM field meters and test data from a central location.

* Available in upcoming software release.

Specifications

Product Specifications

Frequency

Term	4 to 1000 MHz
Accuracy	±10 ppm at 77°F (25°C)
Tuning resolution	Analog 10 KHz, Digital 50 KHz
Channel bandwidth	Models ending in A, 8 MHz Models ending in B, 6 MHz

Level Measurement, Analog

Signal types	CW, video and audio (NTSC, PAL, and SECAM)
Range ¹	-40 to +60 dBmV
Resolution	0.1 dB
Resolution bandwidth	280 KHz
Accuracy ²	±1.5 dB typical @ 25°C
Carrier-to-Noise	Input @ ≥6 dBmV 30 to 45 dB ±2 dB 45 to 48 dB ±3 dB

Level Measurement, Digital

Modulation types	QPR, QPSK, QAM (DVB/ACTS)
Range ¹	-40 to +60 dBmV
Resolution	0.1 dB
Accuracy ²	±2.0 dB typical @ 25°C

Two-Way Ranging Test

DOCSIS based	DOCSIS 1.0, 1.1 and 2.0
Upstream transmit range and diplexer crossover (DOCSIS modes only)	Models ending in A, 5 to 65 MHz 65/96MHz (min. downstream DOCSIS center freq. 100 MHz) Models ending in B, 5 to 42 MHz 42/88 MHz (min. downstream DOCSIS center freq. 91 MHz)
Upstream modulation	QPSK and 16 QAM as instructed by CMTS DOCSIS 2.0 US modulation
Transmitter output	At 25°C, maximum 55 dBmV with 16 and 64 QAM and 58 dBmV with QPSK, (typical)

Downstream QAM Demodulation

Modulation type	64, 128 and 256 QAM, ITU-T J.83 Annex A, B or C (selectable)
Input range (lock range) ³	-15 to +50 dBmV from 55 to 1000 MHz
BER ⁴	Pre- and Post-FEC 10 ⁻⁴ to 10 ⁻⁹
MER ⁵	Range 64 QAM: 21 to 35 dB Accuracy ±2 dB (typical) Range 128/256 QAM: 28 to 35 dB Accuracy ±2 dB (typical)
DQI Channel types:	QAM modulation, symbol rate, interleaver depth
EVM ⁵	Range 64 QAM: 1.2% to 5.8% Accuracy ±0.5% (1.2% to 2.0%) ±1.0% (2.1% to 4.0%) ±1.4% (4.1% to 5.8%) Range 128/256 QAM: 1.1% to 2.4% Accuracy ±0.6%

Symbol rate	Annex A, 5.057 to 6.952 Msps (64 / 128 / 256 QAM) Annex B, 5.057 Msps (64 QAM) and 5.361 Msps (256 QAM) Annex C, 5.274 Msps (64 QAM) and 5.361 Msps (256 QAM)
-------------	---------------------------------------------------------------------------------------------------------------------------------------------------------------------

Note: 128QAM Not defined for Annex B ITU-T J.83

Test Point Compensation (User editable)

Forward path TPC	Max 100 dB Total Forward external loss (dB): 0 to 50 Forward probe loss (dB): 0 to 50
Reverse path TPC	Max 55 dB Total Reverse internal loss (dB): 0 to 55 Reverse external loss (dB): 0 to 55 Reverse probe loss (dB): 0 to 55
Reverse telemetry level (dBmV)	0 to 55
Reverse sweep insertion level (dBmV)	0 to 55

Interfaces

RF	75 ohm, F81 or BNC option Max. sustained voltage 100 VAC, 140 VDC
RS232	Via optional direct cable
Printer compatibility	Epson and Citizen
Ethernet	RJ45, 10 base T, TCP/IP and UDP supported
USB	v1.1 host mode, 150 mA maximum slave (future firmware release)

Standards Compliance

Shock and vibration	IEC 60068
Drop	EC 61010
Handle stress	IEC 61010
Water resistance	MIL-STD-810E
Safety – emissions	EN 55022
Safety – immunity	EN 61000

Upstream Spectrum (Ingress Scan)

Frequency range	Models ending in A, 4 to 65 MHz Models ending in B, 4 to 45 MHz
Sweep rate	Less than 2 seconds; Display scaling 5 and 10 dB/division; 6 vertical divisions
Resolution bandwidth	280 kHz
Range ¹	-40 to 60 dBmV (typical)

Downstream Spectrum (Forward Scan)

Frequency range	4 to 1000 MHz
Sweep rate	Less than 2.5 seconds; Display 5 and 10 dB/division; 6 vertical divisions
Resolution bandwidth	30 or 330 kHz
Dwell	1 ms to 25 ms
Span	50MHz or 10MHz zoom
Range ¹	4 to 100MHz, (typical)

Sweep Specifications

Forward Sweep

Requires SDA-5500 (SDA Compatible mode)

Reverse Sweep

Requires SDA-5500 (Single Reverse) or SDA-5510 (Multiple Reverse) (SDA Compatible mode)

Sweep Modes

Frequency range	5 to 1000 MHz
Display span	user definable
Display scale/range	6 vertical divisions 1, 2, 5, or 10 dB/division
Sweep pulse occupied bandwidth	30 kHz
Stability	±0.5 dB, normalized (dependent on stability of referenced carriers)
Sweep rate	~1 second (78 channels, including scrambled and digital signal types)
Channel plan templates	(user editable on SDA Headend gear) China-1; China-2; France; HDTP-NL; Ireland; Japan; Jerold; Jerold-HRC; Jerold-IRC; NCTA; NCTA-HRC; NCTA-SUB; NCTA-IRC; NTSC-broadcast; OIRT-D/K; PL-B/G; PAL-UK

Constellation

Modulation type	128 and 256 QAM
Zoom capability	Yes

Return QAM Generator

Frequency range	Models ending in B: 5 to 55 MHz Models ending in A: 5 to 65 MHz
-----------------	--------------------------------------------------------------------

Signal level range	8 to 58 dBmV
Signal modulation	CW or 16 QAM
Symbol rates (Msps)	1.28, 2.56, 3.84, 5.12

Cable Modem Diagnostic Page

IP address ⁶	192.168.100.1
-------------------------	---------------

Specifications
General

Display	320 x 240, grayscale, Selectable back light
Language support	(user interface and help system) English in all models No-charge second language option of Spanish, French, German, Hungarian, Japanese, Polish or Chinese
Dimensions	Model 1500, 2500 and 3500: 4.75 x 9.75 x 2.75 in (12 x 25 x 7 cm) Model 2600, 3600, and 6000: 4.75 x 9.75 x 3.25 in (12 x 25 x 8.25 cm)
Weight	Model 1500, 2500 and 3500: 2 lb 12 oz (1.3 kg) Model 2600 and 3600: 3 lb 4 oz (1.5 kg)
Storage and operating temperature range	0 to 120°F; -20 to +50°C
Power	Hi-capacity Li-ion removable pack, standard on DSAM-6000 Hi-capacity Li-ion, 7 hours (typical)
Charge time	Hi-capacity Li-ion, 10 hours (typical)
Power supply input	90-264 VAC, 47-63 Hz

Notes:

- ¹ Total integrated power, detectable range
- ² Accuracy for levels between -20 to 55 dBmV
Additional uncertainty ± 0.5 dB across -20°C to 50°C
Additional uncertainty ± 1.0 dB from 4 MHz to 15 MHz
- ³ Total integrated power, At 64 QAM
- ⁴ DSAM1500, 2500 and 3500 can support up to (I,J) = (128,1) interleave for ITU-T J.83 Annex B; DSAM2600, 3600 and 6000 can support up to (I,J) = (128, 4) interleave for ITU-T J.83 Annex B
- ⁵ Accuracy and behavior from 100 MHz to 1000 MHz for levels between -5 to 50 dBmV (typical)
- ⁶ IP address is specified in the DOCSIS 1.1 and 2.0 operations support system interface (OSS) specifications

All statements, technical information and recommendations related to the products herein are based upon information believed to be reliable or accurate. However, the accuracy or completeness thereof is not guaranteed, and no responsibility is assumed for any inaccuracies. The user assumes all risks and liability whatsoever in connection with the use of a product or its application. JDSU reserves the right to change at any time without notice the design, specifications, function, fit or form of its products described herein, including withdrawal at any time of a product offered for sale herein. JDSU makes no representations that the products herein are free from any intellectual property claims of others. Please contact JDSU for more information. JDSU and the JDSU logo are trademarks of JDS Uniphase Corporation. Other trademarks are the property of their respective holders. ©2006 JDS Uniphase Corporation. All rights reserved. 30137427 000 0606 DSAM6000.DS.CAB.TM.AE

Test & Measurement Regional Sales

NORTH AMERICA TEL: 1 866 228 3762 FAX: +1 301 353 9216	LATIN AMERICA TEL: +55 11 5503 3800 FAX: +55 11 5505 1598	ASIA PACIFIC TEL: +852 2892 0990 FAX: +852 2892 0770	EMEA TEL: +49 7121 86 2222 FAX: +49 7121 86 1222	www.jdsu.com/test
---------------------------------------------------------------------	------------------------------------------------------------------------	-------------------------------------------------------------------	---------------------------------------------------------------	----------------------------------------------------------