

Programmable DC Electronic Load

PEL-2000A Series

USER MANUAL

GW INSTEK PART NO. 82EL-2004AEA1



ISO-9001 CERTIFIED MANUFACTURER

GW INSTEK

January 2016

This manual contains proprietary information, which is protected by copyright. All rights are reserved. No part of this manual may be photocopied, reproduced or translated to another language without prior written consent of the Good Will company.

The information in this manual was correct at the time of printing. However, Good Will continues to improve products and reserves the right to change specification, equipment, and maintenance procedures at any time without notice.

Good Will Instrument Co., Ltd.
No. 7-1, Jhongsing Rd., Tucheng Dist., New Taipei City 236, Taiwan.

Table of Contents

| | |
|---------------------------------------|------------|
| SAFETY INSTRUCTIONS | 5 |
| GETTING STARTED | 10 |
| Main Features | 12 |
| Series Overview | 13 |
| Package Contents and Accessories..... | 15 |
| Measurement Overview | 16 |
| Front Panel Overview | 17 |
| Display Overview – Mainframe | 23 |
| Rear Panel Overview | 27 |
| Front Panel Overview – Load Module... | 30 |
| LED Display Overview – Load Module.. | 34 |
| Installation | 37 |
| Load Connections | 45 |
| Frame Link Connection | 57 |
| Channel Control Connection | 59 |
| Go/NoGo Connection | 62 |
| OPERATING DESCRIPTION..... | 63 |
| Operating Mode Description | 64 |
| Parallel Unit Mode | 75 |
| Run Program..... | 77 |
| Sequence | 80 |
| OCP Test Automation | 85 |
| Parallel Dynamic Loading | 86 |
| Configurations Description | 87 |
| Interface and File System..... | 97 |
| TUTORIALS..... | 104 |
| Local loads | 105 |
| Single Channel Load | 107 |

| | |
|--|------------|
| Parallel Load Modules..... | 109 |
| Programming | 111 |
| Sequences..... | 113 |
| Frame Link..... | 114 |
| Channel Control..... | 116 |
| General Configuration Options | 118 |
| OPERATION..... | 119 |
| Local Mode Operation | 123 |
| Mainframe Basic Operation | 130 |
| Creating a Program Sequence | 156 |
| Edit Sequence | 169 |
| OCP Test Automation..... | 179 |
| Channel Configuration | 186 |
| Mainframe Configuration | 215 |
| Interface Configuration (settings) | 230 |
| Save / Recall | 236 |
| INTERFACE..... | 267 |
| Interface Configuration | 268 |
| FAQ | 276 |
| APPENDIX | 277 |
| Fuse Replacement | 277 |
| Firmware Update | 278 |
| Calibration | 279 |
| Range Chart | 280 |
| Default Settings | 285 |
| Specifications | 287 |
| Dimensions | 298 |
| EC Declaration of Conformity..... | 300 |
| INDEX..... | 301 |

S SAFETY INSTRUCTIONS

This chapter contains important safety instructions that you must follow when operating the PEL-2002A/PEL-2004A, and when keeping it in storage. Read the following before operating the PEL-2002A/2004A to ensure your safety and to keep the PEL-2000A series in the best possible condition.

Safety Symbols

These safety symbols may appear in this manual or on the PEL-2002A/2004A.



WARNING

Warning: Identifies conditions or practices that could result in injury or loss of life.



CAUTION

Caution: Identifies conditions or practices that could result in damage to THE PEL-2002A/2004A or to other properties.



DANGER High Voltage



Attention Refer to the Manual



Protective Conductor Terminal



Earth (ground) Terminal



Do not dispose electronic equipment as unsorted municipal waste. Please use a separate collection facility or contact the supplier from which this instrument was purchased.

Safety Guidelines

General Guideline



CAUTION

- Do not place any heavy object on the PEL-2002A/2004A.
- Avoid severe impact or rough handling that leads to damaging the PEL-2002A/2004A.
- Do not discharge static electricity to the PEL-2002A/2004A.
- Do not block or obstruct the cooling fan vent openings.
- Do not perform measurement at circuits directly connected to Mains (Note below).
- Do not disassemble the PEL-2002A/2004A unless you are qualified as service personnel.
- The equipment is not for measurements performed for CAT II, III and IV.

(Measurement categories) EN 61010-1:2010 specifies the measurement categories and their requirements as follows. The PEL-2002A/2004A falls under category I.

- Measurement category IV is for measurement performed at the source of low-voltage installation.
 - Measurement category III is for measurement performed in the building installation.
 - Measurement category II is for measurement performed on the circuits directly connected to the low voltage installation.
 - Measurement category I is for measurements performed on circuits not directly connected to Mains.
-

Power Supply**WARNING**

- AC Input voltage: 115V/230V switchable, 50/60Hz
 - The power supply voltage should not fluctuate more than 15%.
 - Connect the protective grounding conductor of the AC power cord to an earth ground, to avoid electrical shock.
-

Fuse**WARNING**

- Fuse type: T3.15A/250V
 - Make sure the correct type of fuse is installed before power up.
 - To avoid fire, only replace the fuse with the specified type and rating.
 - Disconnect the power cord before fuse replacement.
 - Make sure the cause of a fuse blowout is fixed before replacing the fuse.
-

**Cleaning the
PEL-2000A**

- Disconnect the power cord before cleaning.
 - Use a soft cloth dampened in a solution of mild detergent and water. Do not spray any liquid.
 - Do not use chemicals or cleaners containing harsh material such as benzene, toluene, xylene, and acetone.
-

**Operation
Environment**

- Location: Indoor, no direct sunlight, dust free, almost non-conductive pollution (Note below)
- Temperature: 0°C to 40°C
- Altitude: Up to 2000m
- Transient Overvoltage on the main supply is 2500V.

(Pollution Degree) EN 61010-1:2010 specifies the pollution degrees and their requirements as follows. THE PEL-2002A/2004A falls under degree 2.

Pollution refers to “addition of foreign matter, solid, liquid, or gaseous (ionized gases), that may produce a reduction of dielectric strength or surface resistivity”.

- Pollution degree 1: No pollution or only dry, non-conductive pollution occurs. The pollution has no influence.
- Pollution degree 2: Normally only non-conductive pollution occurs. Occasionally, however, a temporary conductivity caused by condensation must be expected.
- Pollution degree 3: Conductive pollution occurs, or dry, non-conductive pollution occurs which becomes conductive due to condensation which is expected. In such conditions, equipment is normally protected against exposure to direct sunlight, precipitation, and full wind pressure, but neither temperature nor humidity is controlled.

Storage environment

- Location: Indoor
- Relative Humidity: < 80%
- Temperature: -10°C to 70°C

Disposal



Do not dispose this instrument as unsorted municipal waste. Please use a separate collection facility or contact the supplier from which this instrument was purchased. Please make sure discarded electrical waste is properly recycled to reduce environmental impact.

Power cord for the United Kingdom

When using the PEL-2002A/2004A in the United Kingdom, make sure the power cord meets the following safety instructions.

NOTE: This lead/appliance must only be wired by competent persons



WARNING: THIS APPLIANCE MUST BE EARTHED

IMPORTANT: The wires in this lead are coloured in accordance with the following code:

| | |
|----------------|--------------|
| Green/ Yellow: | Earth |
| Blue: | Neutral |
| Brown: | Live (Phase) |



As the colours of the wires in main leads may not correspond with the coloured marking identified in your plug/appliance, proceed as follows:

The wire which is coloured Green & Yellow must be connected to the Earth terminal marked with either the letter E, the earth symbol  or coloured Green/Green & Yellow.

The wire which is coloured Blue must be connected to the terminal which is marked with the letter N or coloured Blue or Black.

The wire which is coloured Brown must be connected to the terminal marked with the letter L or P or coloured Brown or Red.

If in doubt, consult the instructions provided with the equipment or contact the supplier.

This cable/appliance should be protected by a suitably rated and approved HBC mains fuse: refer to the rating information on the equipment and/or user instructions for details. As a guide, a cable of 0.75mm² should be protected by a 3A or 5A fuse. Larger conductors would normally require 13A types, depending on the connection method used.

Any exposed wiring from a cable, plug or connection that is engaged in a live socket is extremely hazardous. If a cable or plug is deemed hazardous, turn off the mains power and remove the cable, any fuses and fuse assemblies. All hazardous wiring must be immediately destroyed and replaced in accordance to the above standard.

G E T T I N G S T A R T E D

This chapter describes the features and functions of the PEL-2002A/2004A, including the front and rear panel appearance, panel installation and connection types. Use the Tutorial section for quick access to step by step instructions on the main functions.



| | |
|---|-----------|
| Main Features | 12 |
| Series Overview..... | 13 |
| Package Contents and Accessories | 15 |
| Measurement Overview | 16 |
| Front Panel Overview | 17 |
| Display Overview – Mainframe | 23 |
| Rear Panel Overview..... | 27 |

| | |
|---|-----------|
| Front Panel Overview – Load Module..... | 30 |
| LED Display Overview – Load Module | 34 |
| Installation | 37 |
| Load Module Installation | 37 |
| GPIB Installation | 40 |
| Rack Mount Installation..... | 41 |
| Channel Number..... | 42 |
| Power Up & Self Test | 43 |
| Load Connections | 45 |
| Precautions and Procedures | 45 |
| Remote (Sense) Connection..... | 50 |
| Single Load Connections..... | 52 |
| Parallel Load Connections..... | 54 |
| Frame Link Connection..... | 57 |
| Channel Control Connection..... | 59 |
| Go/NoGo Connection | 62 |

Main Features

Description The PEL-2002A and 2004A are multichannel programmable DC electronic load mainframes. The PEL-2002A mainframe is able to hold 2 load modules, whilst the PEL-2004A is able to hold 4. The flexible module configuration allows the mainframes to either sink multiple loads independently or large loads when used in parallel.

The PEL-2000A series support four operation modes: constant current (CC), constant voltage (CV and CV+CC), constant resistance (CR) and constant power (CP). Constant current and constant resistance mode can operate in either static or dynamic mode.

- Feature Overview**
- Flexible operation with removable load modules
 - Multiple independent isolated channels
 - High performance, up to 5 digit resolution
 - High slew rate enabling a high response speed
 - High capacity when frame linked
 - Different load module types can be used in the same mainframe
 - Dedicated parallel mode.
 - Supports rack mount installation (PEL-2004A)
 - Supports frame link connections, with up to 4 slave units
 - Color LCD display
 - 120 different sets of programmable sequences
 - Accurate load simulation using Sequences
 - 4 panel setups
 - USB flash drive support
-

| | |
|-----------|---|
| Interface | <ul style="list-style-type: none">• USB• RS-232C• GPIB (optional) |
|-----------|---|

Series Overview

The PEL-2000A series comprises of two different Mainframes: the PEL-2002A and the PEL-2004A. The Mainframes differ by the number of load module slots that can be accommodated. The PEL-2002A has two load module slots whilst the PEL-2004A has 4. There are 4 different load module models, the PEL-2020A, PEL-2030A, PEL-2040A and PEL-2041A.

PEL-2004A Mainframe

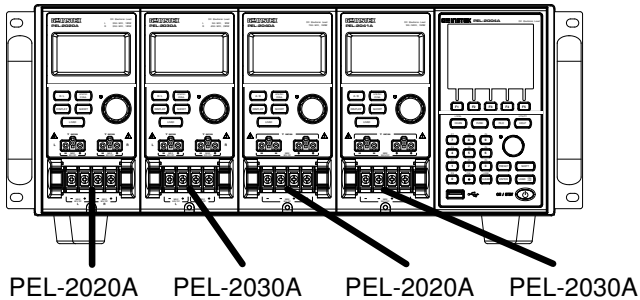

PEL-2002A Mainframe

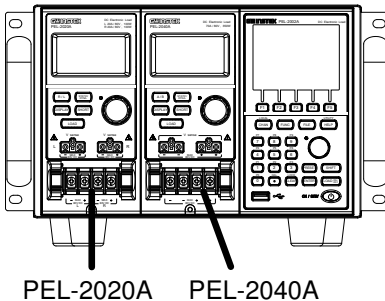

The 4 different load module models each differ in the amount of current, voltage and power and the number of channels that the load module can accommodate. The procedures in this manual will be load module model independent unless specifically stated. Below is a table showing the basic differences between each load module model. For detailed specifications, please see page 287.

| Load Module | Channels | Power (W) CH L/R (low/high range) | Current (A) Range Low/High | Voltage (V) |
|-----------------------------|----------|--|----------------------------------|-------------|
| PEL-2020A (100Wx2) | 2 | 100/100 | 2/20 | 1-80 |
| PEL-2030A (30/(25/250W)) | 2 | 30/(25/250) | 5/4/40 | 1-80 |
| PEL-2040A | 1 | (35/350) | 7/70 | 1-80 |
| PEL-2041A | 1 | (35/350) | 1/10 | 2.5-500 |

Package Contents and Accessories

The PEL-2000A electronic load generator has a number of standard and optional accessories that can be ordered. For more information please visit the GW Instek website at www.gwinstek.com or consult your authorized distributor for details.

| Standard Accessories | Description |
|----------------------|---|
| Power Cable | Mains power cable (region dependent) |
| CD ROM | Contains PEL-2000A Series Electronic DC Load User Manual, Programming Manual and USB Driver |
| GTL-120 | Load cables 2X red, 2X black (per load module) |
| GTL-121 | Remote sense cables , 1X red, 1X black (per load module) |

| Options | Description |
|-----------|------------------------------------|
| PEL-2020A | Load Module |
| PEL-2030A | |
| PEL-2040A | |
| PEL-2041A | |
| PEL-001 | GPIB interface (Factory installed) |

| Optional Accessories | Description |
|----------------------|--|
| PEL-002 | PEL-2000A Rack Mount kit (handle only) |
| GTL-232 | RS-232C |
| GTL-246 | USB |
| GTL-248 | GPIB cable |
| GTL-249 | Frame link |

Measurement Overview



The PEL-2000A series has a number of different operating modes that are completely configurable. All the modes have customizable Go/NoGo limits, range limits, timers, slew rates, alarms and protection limits. For parallel loads, there is a dedicated Parallel configuration mode. To make tests, Programs and Sequences can be created.

| Function | Description |
|--------------------------------|---|
| Constant Current Mode (CC) | In constant current mode, the PEL-2002A/2004A will sink a constant amount of current, regardless of the voltage. |
| Constant Voltage Mode (CV) | Under constant voltage mode, the voltage remains unchanged, regardless of the current. |
| Constant Resistance Mode (CR) | In constant resistance mode, the resistance load will remain unchanged as the voltage and current remain proportional. |
| Constant Power Mode (CP) | In constant power mode, the PEL-2000A will ensure the power consumed is constant. |
| Programmable Sequences (Prog.) | The PEL-2000A series supports programming sequences. With up to 120 different memory settings in 12 programs with 10 sequences. |
| Sequences (Seq.) | Used to create load profiles to accurately simulate a load. Sequences can be created for each channel. |
| Parallel Unit Mode | Parallel Unit Mode enables the PEL-2000A mainframes to easily use load modules (of the same type/rating) in parallel. Parallel mode is used in conjunction with CC or CR modes. CP and CV mode cannot be used with this mode. |

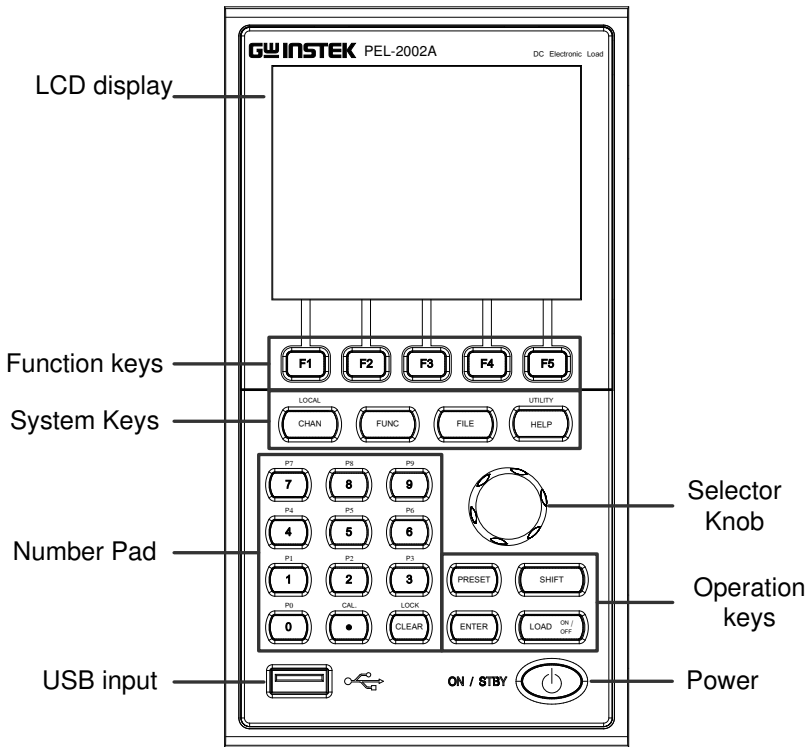
Front Panel Overview



LCD display 320 by 240, TFT LCD display.

Function keys  ~  Assigned to the menu functions on the bottom of the display.

System Keys

LOCAL
 CHAN/LOCAL is used to select the load channel. Combined with the shift key, Local is used to activate/deactivate local control (during remote control via the interface or frame link connections).

LOCAL
 Brings up the Channel Menu.

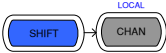
LOCAL
 Used to activate local control mode during remote control via the interface

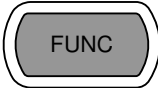
 Used to access the Program, Sequence or Parallel menu.

 Used to access the File menu.

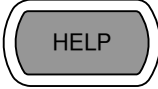
UTILITY
 Brings up the Help menu and utility menu.

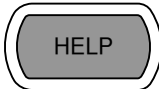
UTILITY
 Provides help for the last function /key pressed.

UTILITY
 Activates the Utility Menu.

Number pad



Enter numerical values, or to save/recall presets (P0-P9).

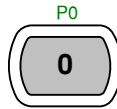

Number values.

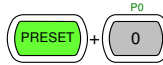

Preset numbers P0-P9.

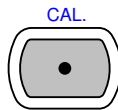

Decimal point and Calibration key

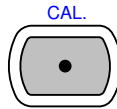

Decimal point.



Activate calibration mode.



Note

Please note, calibration mode is not supported. Please see your distributor for calibration needs.



Clears current values. Alternative function locks the keys and the Selector knob.

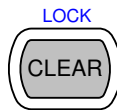

Clears the current value.



Locks all the keys and Selector knob.

USB Input



USB flash memory slot.

Selector Knob

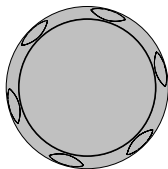

Used to select operations and to increase/decrease values.

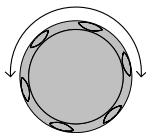

When turned left or right moves the cursor in menus or changes the selected item or value.

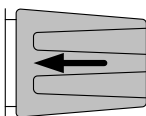

When pushed down, acts as the Enter key.

Operation Keys



Saves and recalls preset settings and values.

When pressed in combination with the number pad, Presets P0-P9 can be recalled or saved.



Inactive



Active. Used in combination with the number pad and/or shift key.



Press to recall a channel preset

Hold to save a channel preset

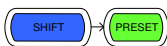

Press to recall all channel presets.

Hold to save all channel presets.

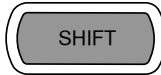

The shift key is used to access alternate functions assigned to select keys.

The shift key is also used to toggle between coarse and fine control mode when used in conjunction with the selector knob to adjust parameters.

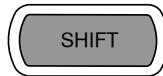

Inactive mode.

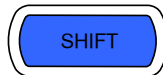

Active. When active the shift key can be used to access the Local and Utility menus.

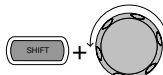

Coarse control mode.

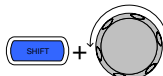

Fine control mode



Confirms selections.



Turns the current load/channel on or off

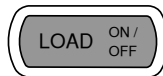

Load is currently off. (unlit)

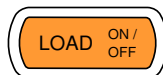

Load is currently on. (orange light)

Power

ON / STBY  Turns the unit on or into standby mode.

ON / STBY  Standby mode.

ON / STBY  On.

Display Overview – Mainframe

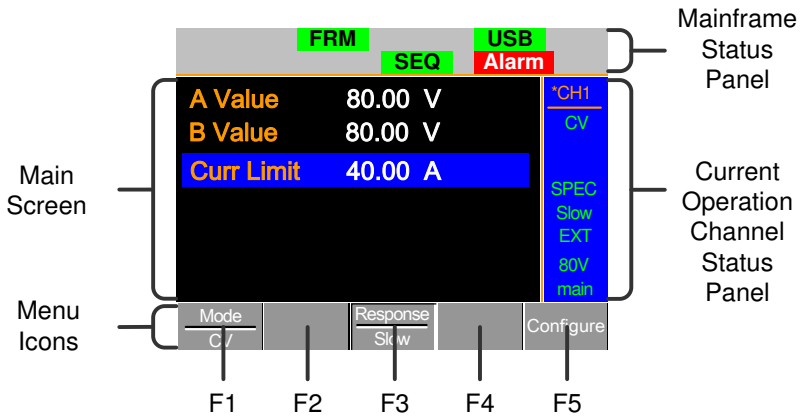

Mainframe Status Panel The Mainframe Status Panel displays the status of the Mainframe interface, programs and alarm status.

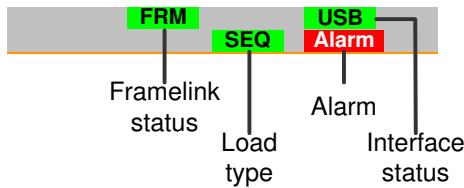

Frame Link Status



Indicates Frame Link is turned on and that the mainframe is set as either a master (FRM) or slave (FRS) unit.

Load Type

The Load Type Icon indicates if a Sequence (SEQ) or Program (PROG) is turned on. If not then LOAD is displayed as default. When any Load type is running, their icon will turn orange.

Interface Status

The interface status icon displays which interface type is set.

Current Operation Channel Status Panel

The Current Operation Channel Status panel generally displays the status of the current channel.

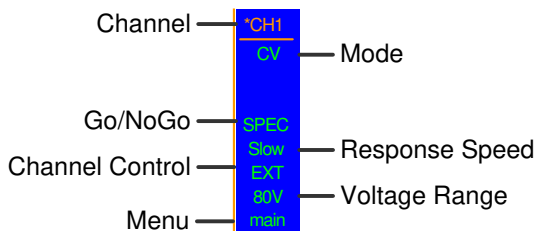

| | | |
|---------|-------------|-------------------------------|
| Channel | CH1~ CH8 | Displays the current channel. |
| | *CHx | * = independent mode |
| | CHxS | S = Parallel Sync mode |
| | CHxP | P = Parallel mode |

| | | |
|-----------------|--|---|
| Mode | Displays the current mode. | |
| | CCL | CC Static Low Range |
| | CCH | CC Static High Range |
| | CCDL | CC Dynamic Low Range |
| | CCDH | CC Dynamic High Range |
| | CRL | CR Static Low Range |
| | CRH | CR Static High Range |
| | CRDL | CR Dynamic Low Range |
| | CRDH | CR Dynamic High Range |
| | CV | CV Mode |
| | CPL | CP Low Range |
| | CPH | CP High Range |
| Go/NoGo | SPEC | If Go/NoGo is turned on, SPEC will be displayed. |
| Response Speed | Slow Fast | In CV mode the response speed will be shown, Slow or Fast. |
| Channel Control | EXT | When Channel Control is set to External, EXT will be displayed. |
| Voltage Range | Displays the voltage range of the current setting. | |
| Menu | Shows the current menu. | |
| | main | = Chan menu |
| | conf | = Chan→Configure menu |
| | s_edit | = Chan→Seq.Edit menu |
| | file | = File menu |
| | s_loop | = Chan→Seq.Edit→Loop menu |
| Main Screen | Main display screen. | |

| | | |
|------------|-------|---|
| Menu Icons | F1~F5 | Each Menu Icon is controlled by the F1~F5 function keys directly below. |
|------------|-------|---|

Rear Panel Overview

PEL-2004A

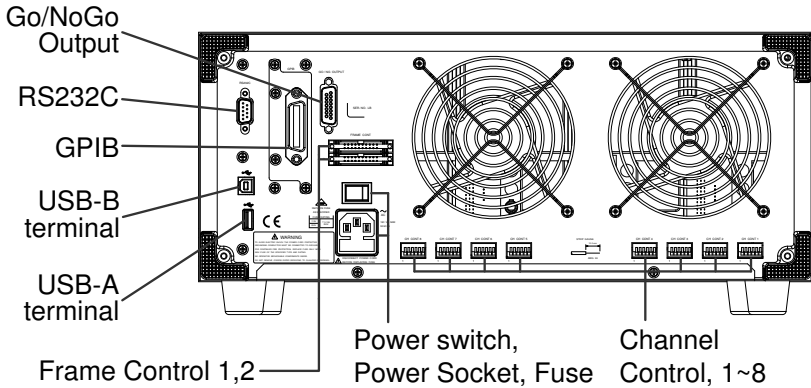

PEL-2002A

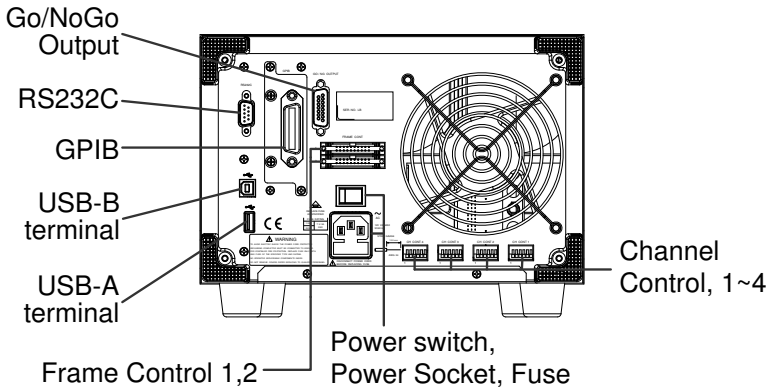

Go/NoGo Output

GO / NG OUTPUT

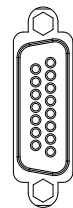

The Go/NoGo Output terminal outputs a pass (high)/fail (low) voltage for each channel.

See page 274, 62 for details.

RS232 port/
GPIB port

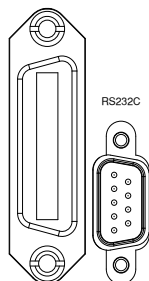

The RS232 and GPIB port is used for remote control connections.

RS-232C: DB-9 pin male

GPIB: 24-pin female

See pages 268, 269 for remote control details.

USB-A(host)/
USB-B (device)
port

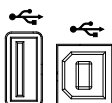

The USB-B (device) port, like the RS232/GPIB port is used for remote control. Like the front panel, the USB-A port is used for data storage.

See page 97 for interface details.

Frame Control
Port

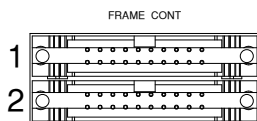

The Frame Control port is used for Frame Link connections. Mainframes are daisy-chained together. There are two Frame control ports.

- 1: Slave
- 2: Master

Connection type: MIL 20-pin connector.

For details about frame link connections see page 57, 271.

Power Switch

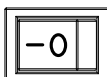

External Power Switch

Power Socket/
Fuse

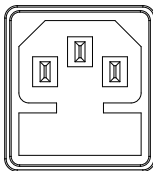

The power supply socket accepts the AC mains Voltage. The fuse holder is located below the power socket.

Power: 50/60 Hz (180 VA)

Fuse: T3.15A/250V

For fuse replacement details see page 277.

Channel
Control port
(1~8)



Each channel has a dedicated Channel control port to enable external monitoring and control. The channel control port has 6 wire sockets that are screw-less and self clamping.

Required wire gauge: 24
AWG

For connection or specification details see pages 59 & 270.

Front Panel Overview – Load Module

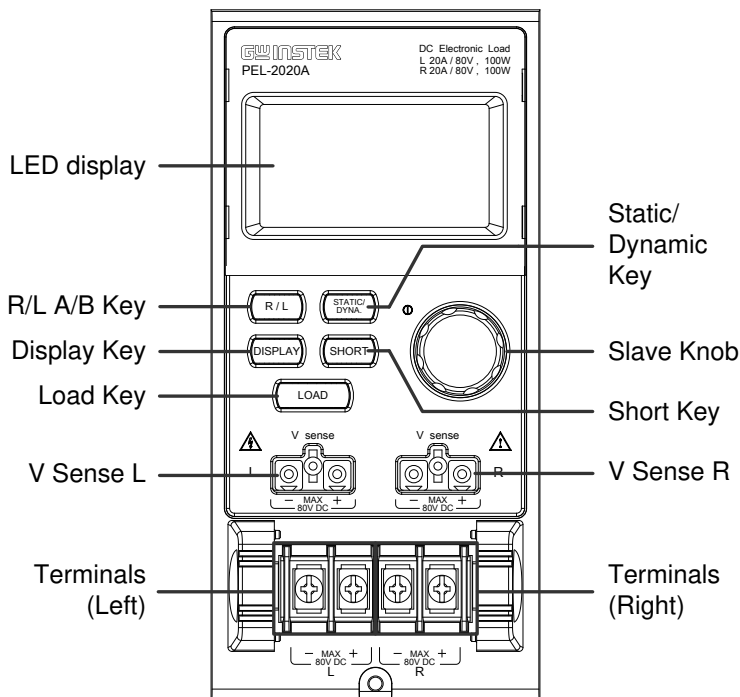

LED display 2x5 digit custom LED display.

Right/Left Key
or
A/B Key



The L/R key is used to switch between the right and left load channel on a dual channel load module. The A/B key is used to switch between A&B Values for single channel load modules.

Display Key



Used to alternate the display output on the load module.

00000 _A Current

0.000 _V Voltage

0.00 _W Power

0.0 _s Load time

Load Key



Activates the load for the active channel. (Right or Left)(A or B)

Left Voltage Sense

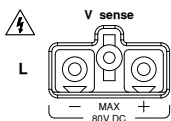

The voltage sense terminals are used when precise measurement is needed. V Sense terminals are used to compensate for voltage drops across the main terminals caused by the resistance of the load wires.

Right Voltage Sense

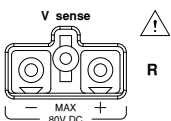

It is automatically activated when connected to a DUT.

Positive and Negative Terminals Left

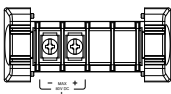

The terminals for both the left and right side of a load can draw differing amounts depending on the load module specifications.

Positive and Negative Terminals Right

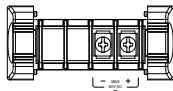

For 2 channel load modules, the left terminals are used for the 1st channel and the right terminals are used for the 2nd channel.

On single channel load modules, the left terminals are the lower (-) potential terminals, whilst the right terminals are the positive (+) potential terminals.

Static/Dynamic Selector Key

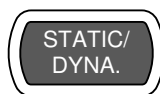

The STATIC/DYNA. Key manually switches the load from Static (manual) to Dynamic loads.

Dynamic loads are only supported in CC and CR mode. For more information see page 64 & 67.

Slave Knob (Load)

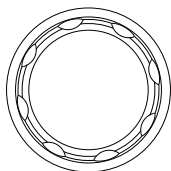

The Slave Knob is used to edit and vary parameters for the active channel on the local load. Depending on the Mainframe setup, the Slave Knob will either only update the load (locally) or will update both the local module and the mainframe*. The Slave Knob can also be configured to display measured or set values on the local load module**.

* For more information on “Knob Type”, see page 223.

** For more information on “Slave Knob”, see page 227.

Short Key



The SHORT key is used to manually short circuit the active channel on the local active load. When a load is off, the SHORT key will toggle the Short key type.



Hold: Hold the SHORT key to short the channel load.

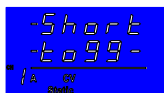

Toggle: Press the SHORT key to toggle shorting the load on or off.

Load on: Pressing or holding the SHORT key will short the load, depending on the short type selected.

LED Display Overview – Load Module



① & ②
Channel Display



R or **L** Left and right channel indicator.



5 digit display.

③ & ⑦
Channel Number Indicator



Indicates the channel number (1-8).

L-ON

Indicates if the load is active on the load module. (Dual channel load modules)

ON

Indicates if the load is on for single channel load modules.

4
Mode Indicator

The Mode Indicator LEDs will indicate what the current mode or settings are on the active channel(s).

AB CC CV CR CP Disp. GO
LR Static Dyna. Short NG

A or B Value A or B for a single channel load module. Applies to CR, CV, CP and CC static mode only.

CC Constant Current Mode (CC) mode activated.

CV Constant Voltage Mode (CV) mode activated.

CR Constant Resistance Mode (CR).

CP Constant Power Mode (CP).

Disp. Display is shown on dual channel load modules when both left (L) and right (R) channel information is displayed.

Press the Display button repeatedly to show information for both channels.

GO Lights up when Go/NoGo is activated and the load passes (GO) the Go/NoGo limits.

L or R L or R will light up when the left or right channel is selected.

Static Lights up when in Static mode.

Dyna. Lights up when in Dynamic mode.

Short Lights up when a load is shorted.

NG Lights up when Go/NoGo is activated and the load fails (NG) the Go/NoGo limits.

⑤ & ⑥
Channel Unit
Indicators



The Unit Indicators display the current unit.

V Voltage

Ω Resistance

A Current

W Power

Installation

The installation chapter describes how to load the different load modules, install the optional GPIB card, the rack mount kit and how to determine each channel number.

Load Module Installation



WARNING

To avoid static electricity, please use appropriate anti-static work practices.

Module
installation

The PEL-2004A and 2002A can accommodate 4 and 2 load modules, respectively. Module loads can have 1 or 2 channels. Installation of load modules is the same for both models.

Steps

1. Ensure the PEL mainframe is turned off from the rear panel. Disconnect the power cord.

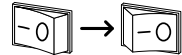

2. Slide the module onto the rails of an empty load slot.

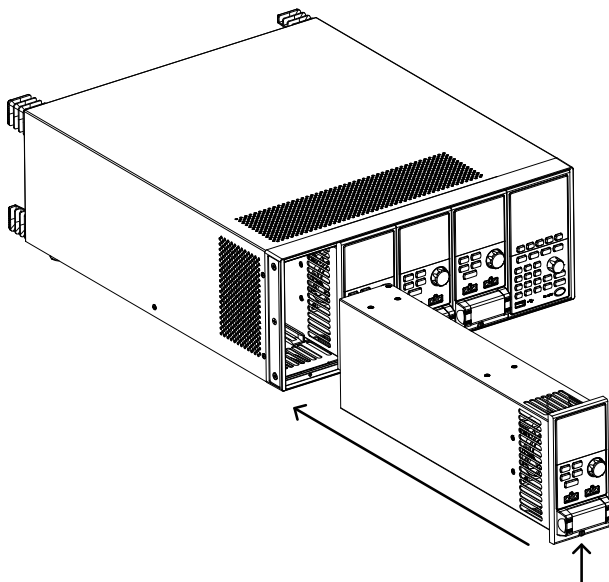

3. Use the supplied screw to fix the module to the load slot, located under the load terminals.

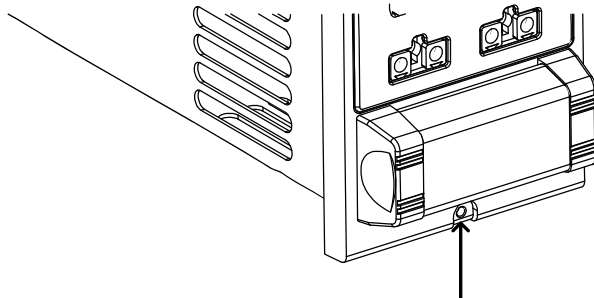

4. Install any additional modules as described above.
5. If there are any slots empty, install the supplied panel cover (GW Instek part number: 63FP-AG106501). The panel cover will improve safety and increase air flow.

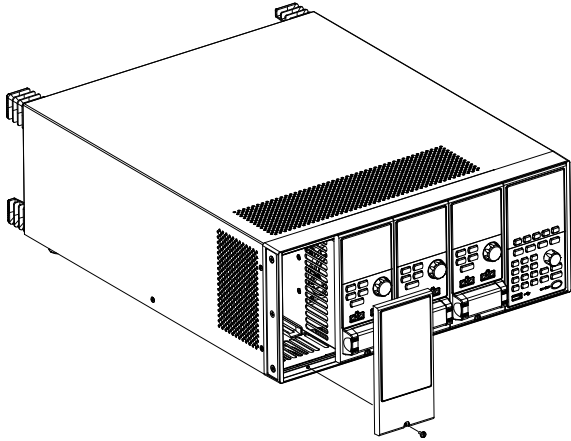

6. Use the supplied screws to fix the panel cover(s) over the load slot.

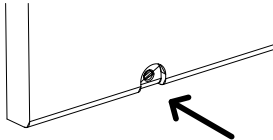

GPIB Installation



WARNING

To avoid static electricity, please use appropriate anti-static work practices.

GPIB Card installation

The PEL-2004A and 2002A has GPIB as an option (GW Instek part no. PEL-001).

Steps

1. Ensure the mainframe is disconnected from mains power.
2. Remove the screws from the GPIB cover plate and remove the cover plate from the rear panel.
3. Slide the GPIB card into the slot and push gently until the back plate is flush with the rear panel.

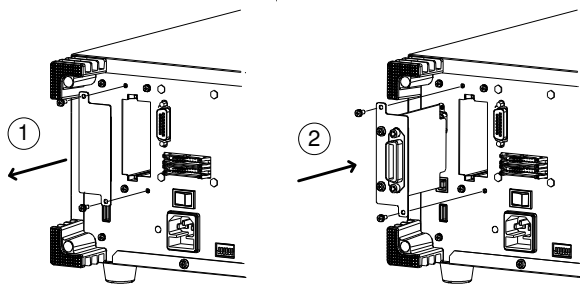

4. Use the screws that were removed from step 1 to secure the GPIB card.

Rack Mount Installation

Background The PEL-2004A can be used in a standard 19" rack mount enclosure with the optional rack mount kit (GW Instek part no. 11EL-20040201). Each unit requires a rack height of 4U with a 1U space for ventilation top and bottom. The rear of the rack mount enclosure must be free of obstruction to allow heat to dissipate from the mainframe(s).

Steps 1. Screw the rack mount brackets as shown below using the supplied bolts.

PEL-2004A

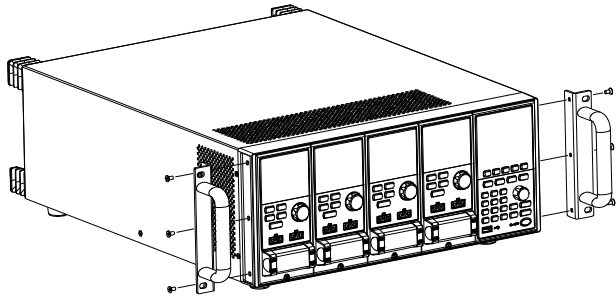

2. Insert into a standard 19" rack enclosure with at least 1U of space top and bottom for ventilation.

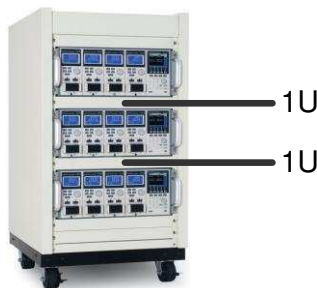

Channel Number

Description

The channel number for a module load is determined by which slot it occupies on the mainframe chassis. There can be 1 or 2 channels per slot, depending on the load module type.

The PEL-2002A has two slots; The PEL-2004A has 4 slots. Channel 1 is the farthest away from the main display panel and channel 8 (PEL2004A) or channel 4 (PEL-2002A) is the closest to the main display panel.

Below the PEL-2004A has all 4 slots occupied with the PEL-2020A, 2030A, 2040A & 2041A series load modules (LM), respectively. The PEL-2020A & 2030A have 2 channels per load module, the PEL-2040A & 2041A have only 1. So the channel determination is:

LM1: CH1, CH2; LM2: CH3, CH4; LM3: CH5;
LM4: CH6.

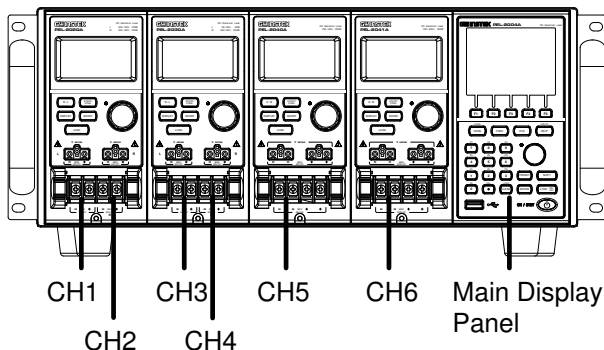

Power Up & Self Test

Panel operation

1. Connect the power cord to the power socket.

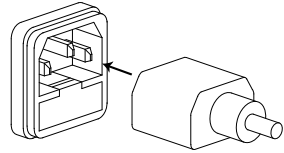

2. Turn the external power switch on.

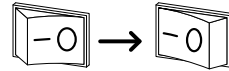

3. Hold the power button on the front panel to turn on the power.



The power button turns green from red (standby).

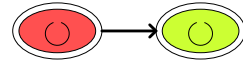

WARNING

Ensure that the power outlet has a ground socket. The power outlet will have a ground connection if it is a 3 socket type.

Upon turning on, the Mainframe will perform a self-test. The self-test checks the System, followed by any attached channels.

| | | |
|----------------|---------------|----------------|
| Initial | System | Success |
| | CH1 | Success |
| | CH2 | Success |
| | CH3 | Success |
| | CH4 | Success |
| | CH5 | Success |

When the system check happens, the load modules will display each channel as it is checked, then display the current mode.

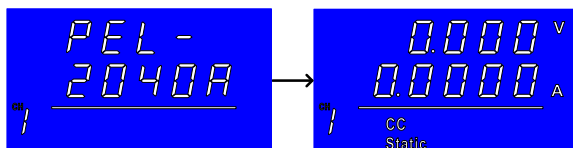

- If any of the System checks fail, please power down the load generator and reinstall the appropriate load module(s).
- To turn off the load generator, hold the power button for a few seconds.



The PEL mainframe will return to standby mode.



Load Connections

Precautions and Procedures

Introduction The PEL-2000A load generator supports a number of different load configurations for flexible operation.

- Single DUT, single load
- Single DUT, parallel load
- Multiple DUTs, multiple loads
- Multiple DUTs, multiple mainframe loads
- Single DUT, parallel mainframes
- DC loads
- Low voltage connections

The PEL-2000A also supports a number of different control methods and interfaces. The connections used are described here:

- Frame link
- Channel control
- Go/NoGo

Wire Gauge considerations Before connecting the PEL-2000A, wire gauge must be taken into account. Load wires must be large enough to resist overheating when a short-circuit condition occurs as well as maintain a good regulation. The size, polarity and length of a wire are all factors in determining if a wire will withstand short circuiting.

Wire Selection Wires that are selected must be large enough to withstand a short circuit and limit voltage drops to no more than 2V per wire. Use the table below to help make a suitable selection.

| AWG | Max Current A(Amp) |
|-----|--------------------|
| 24 | 7.64 |
| 22 | 10.0 |
| 20 | 13.1 |
| 18 | 17.2 |
| 16 | 22.6 |
| 14 | 30.4 |
| 12 | 40.6 |
| 10 | 55.3 |

Load Line Inductance Considerations When using the PEL-2000A load generator, voltage drop and voltage generated due to load line inductance and current change must be taken into account. Extreme changes in voltage may exceed the minimum or maximum voltage limits. Exceeding the maximum voltage limit may damage the PEL-2000A.

To determine the voltage generated, the following equation can be used.

$$E = L \times (\Delta I / \Delta T)$$

- E= voltage generated
- L=load line inductance
- ΔI = change of current (A)
- ΔT = time (us)

Load line inductance (L) can be approximated as 1uH per 1 meter of wire. ($\Delta I / \Delta T$) is the slew rate in A/us.

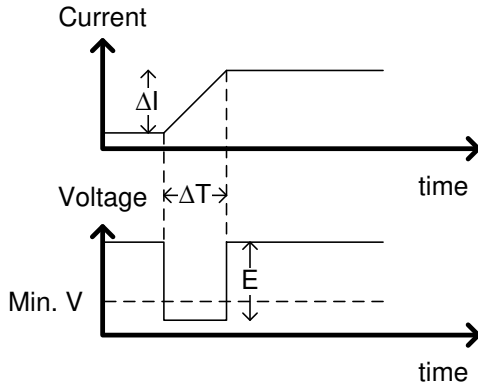

The diagram above shows how changes in current can affect voltage.

Limiting Load line inductance Load line inductance can be reduced by ensuring load wires are as short as possible and by twisting positive and negative load wires together. Current change can be limited by limiting the slew rate when switching.

“Twisted pair” will be shown on any connection diagram where the load wires should be twisted together.

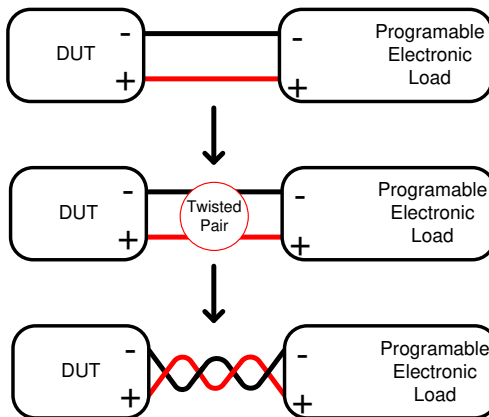

Load module considerations The PEL-2000A supports single and dual channel load modules.

Single channel load modules have one bank of negative terminals and one bank of positive terminals. Each terminal pair has a 40A capacity. For higher loads, each terminal can be wired in parallel to increase capacity.

Dual channel load modules have one bank of positive and negative terminals for each channel.

Single Channel Load Module

Dual Channel Load Module

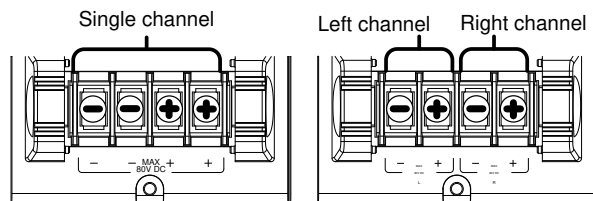

Connection Follow the procedure below for all load connections.



Ensure that power is off from the load generator and the DUT before making any connections.

- Steps**
1. Carefully lift the terminal covers.
 2. Connect the positive (+) terminal on the load module to the high potential output of the DUT.
 3. Connect the negative (-) load terminal to the low potential output of the DUT.

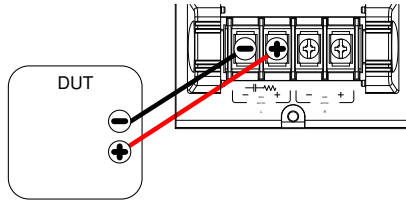

4. Close the terminal cover securely. Ensure the wires are secured properly and that the wires are not exposed when the cover is in place.



WARNING

Ensure that the wires are tied or twisted together to prevent noise and inductance.



CAUTION

Ensure the polarity is correct before proceeding with any connections. Using the wrong polarity could result in reverse voltage damage.

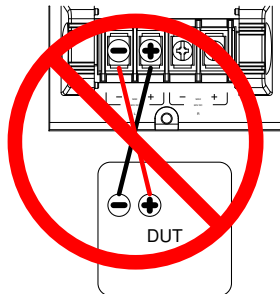

Ensure the input voltage doesn't exceed specifications. Exceeding the voltage specifications could result in damage to the instrument.

Remote (Sense) Connection

Background The electronic load modules have two voltage sense contacts: Vsense L(black), Vsense R(red). Voltage sense can be used to help compensate for long cable length. The longer the cable, the higher the potential resistance and inductance, therefore a short cable is best. Twisting the cable can help reduce induced inductance and using the Vsense terminals compensates the voltage drop seen across the load leads, especially leads with higher resistance. This is useful when used in CV, CR or CP mode.



WARNING

VsenseR (red) must have a higher (+) potential than VsenseL (black).

Connection The diagram below shows how a DUT can be connected using voltage sense. Note that the sense wires are also twisted pairs.

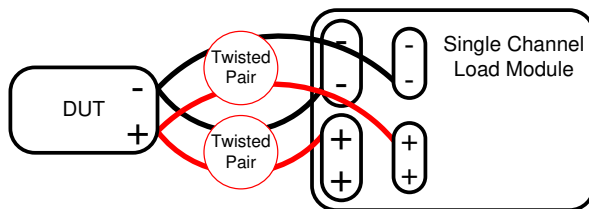

Note

The wire gauge for the sense wires should be no smaller than 16 gauge.

Input The voltage sense terminals must use a wire gauge of 16 to 14.

**Remote Sense
Terminal
connection**

The voltage sense terminals use a screw-less clamp connector. The clamp must be opened prior to inserting a wire. Use a small screwdriver to push the clamp release mechanism. Insert both wires then release the clamp mechanism.

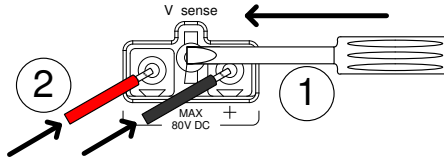

Single Load Connections

Dual Channel Load Module Connection

A dual channel load module can be used to sink two loads concurrently.

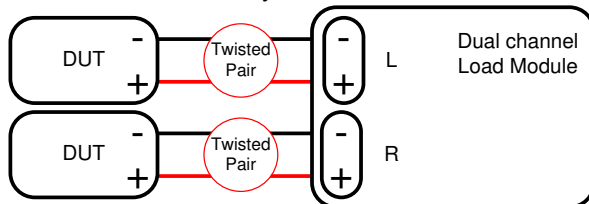

Single Channel Load Module Connection

On a single channel load module, the left terminals are both negative (-), whilst the right terminals are both positive (+). Note this also applies to the voltage sense terminals.

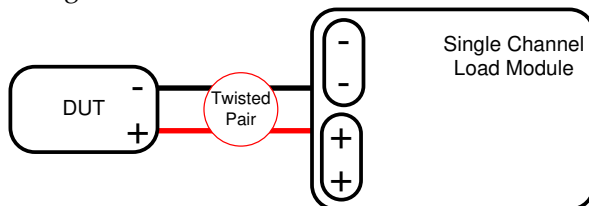

 CAUTION

For loads exceeding 40A, both positive and both negative terminals must be used in parallel.

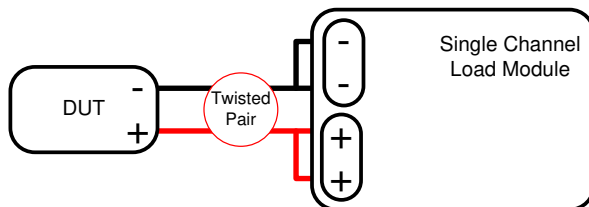

DC Connection For purely DC operation, a resistor and capacitor can be connected in parallel to the electronic load to reduce oscillation. The capacitor and resistor values are dependent on the load settings. Ensure the capacitor ripple current is within allowable limits.

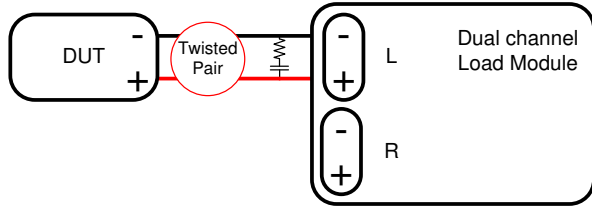

Low Voltage Connection Using the load generator with low voltage loads is generally limited to over 1 volt (load module dependent). In order to support low voltage loads, an auxiliary power supply is needed to boost the voltage to a range suitable for the load generator.

Precautions:

- Take into account the combined power of the load and auxiliary power supply.
- Make sure the auxiliary power supply is able to provide enough current.
- Take into account any noise or irregularities from the auxiliary supply.

The diagram below shows a typical connection.

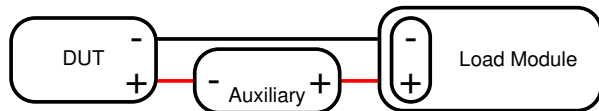

WARNING

Using an auxiliary power supply may induce reverse current. The PEL-2000A series has reverse voltage protection. For details see the protection section on page 87.

Parallel Load Connections

Parallel load modules

When the power output of a DUT exceeds the power rating of a channel or load module, the channel terminals, load modules or mainframes can be used in parallel to dissipate more power when used in CC or CR mode. Each channel will sink the amount of current specified. The total power sunk is the sum of all channels/modules. The amount of power can vary from each channel. For example if CH1 is 25A and CH2 is 20A, then the total current sunk is 45A. Parallel loads are supported for both static and dynamic loads (see page 85 for a description on parallel dynamic loading). Note that the same modules must be used when operating the parallel.

The PEL-2000A also features a dedicated parallel configuration setting known as Parallel Unit. When Parallel Unit is turned on, load modules of the same type and rating to be used in parallel for CC and CR mode. See page 75 and 211 for more information.

Parallel load

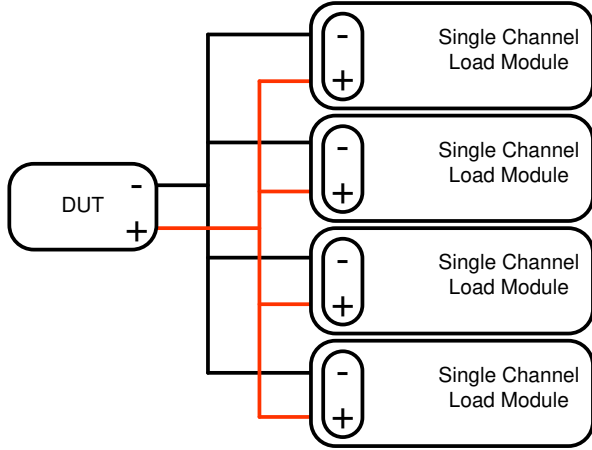

Note

Please note that the same load modules must be used in parallel.

Parallel loads using frame link connections

The PEL-2000A mainframes can also be connected in parallel. Please note, when using a frame link connection there is a delay between the master and the slave. Please see page 57 for details.

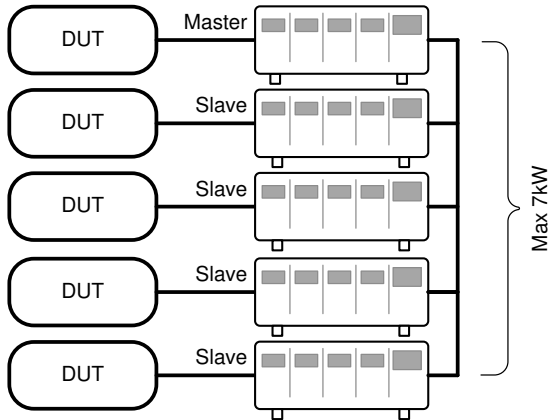

Multi-output power supply load

The PEL-2000A is also able to sink a number of loads concurrently from multiple DUTs or sink a number of loads from the same DUT (i.e. multiple output power supply).

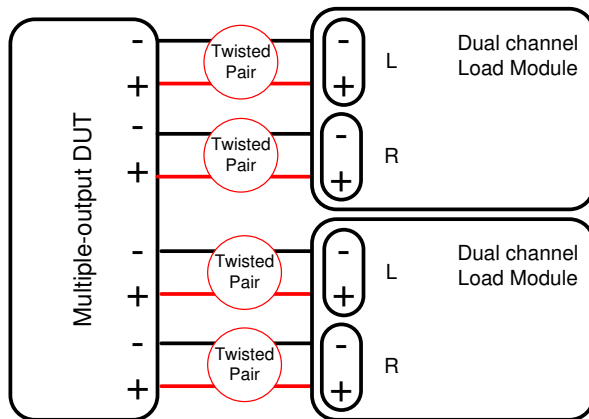

Frame Link Connection

Background

Frame link control involves connecting multiple mainframes using the frame link connections. Up to 4 slave mainframes can be connected to the master mainframe. The first mainframe (master) can be used to control the other slave frames. There is a delay time of 2ms between the master and first slave mainframe, and 4ms, 6ms, and 8ms to the second, third, and fourth slave mainframes, respectively. The connectors used are standard MIL 20-pin connectors. For pin arrangement, see page 271. The frame link cable (part no. GTL-249) is an optional accessory, see page 15 for details.

Frame Link Connection

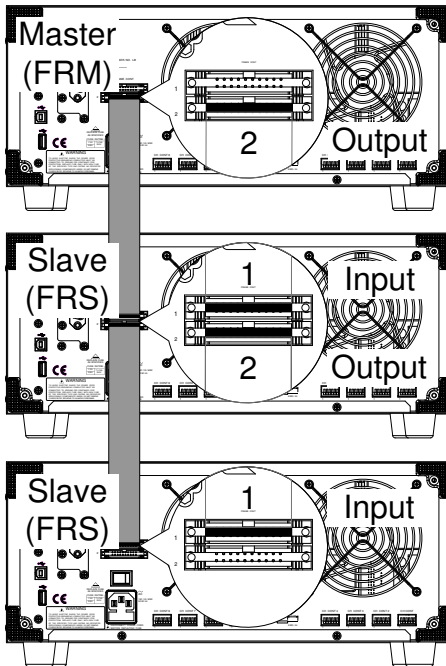

The first mainframe that is connected is the master frame; any additional frames are slave units. The ribbon cable connects to the master from connector 2, and the slave from connector 1. Each successive slave unit is connected in a cascading manner the same way.

Ensure the Mainframes are turned off before connecting the ribbon cables. Push the cable into the frame link connector. Ensure the arrows line up. The latches will close when the connection is complete. To remove, pull the latches out and connector will come out.

Insertion

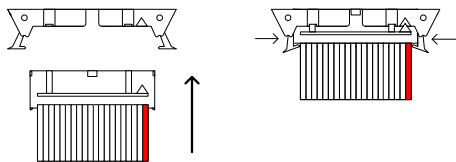

Removal

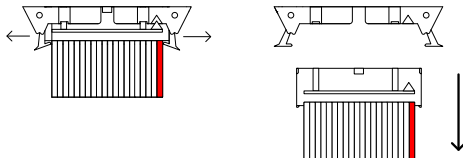

Ensure all the mainframes are off and disconnected from mains power before connecting.

Channel Control Connection

Background

The Channel Control connectors are located on the rear panel of each mainframe. There are two channel control connectors for each load slot, one for each channel, if applicable. The channel control connector is used to externally:

- Turn on/off loads.
- Supply a reference voltage.
- Monitor the load input.

For further details on channel control and the interface see pages 93, 270.

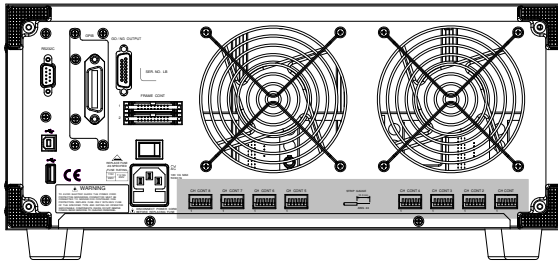

The Channel Control input/output pin layout is shown below.

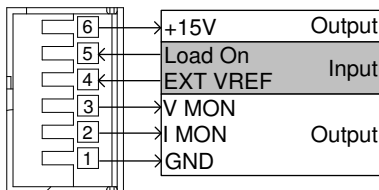

External Voltage Connection The external voltage reference input must be between 0~10V.

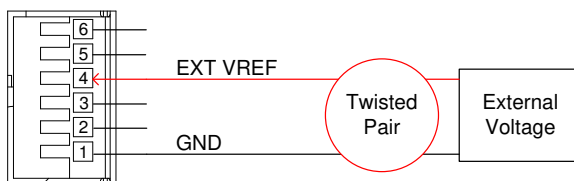

WARNING

Ensure the external voltage reference is stable and has low noise. The External Voltage should be no more than 10V.

No more than 12 volts may be used as an external voltage. More than 12 volts may damage the load generator.

Load on connection

To turn a load on, an active low voltage (0-1V) must be applied across Load On (pin 5) and GND (pin 1), similarly an active high voltage (4-5V) must be applied to turn a load off. The Load On input must be TTL.

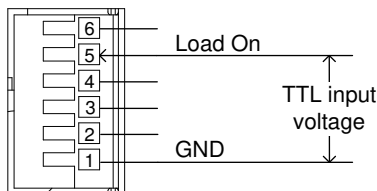

Voltage and Current Monitor Output

The Voltage Monitor Output (VMON) and Current Monitor Output (IMON) output the load input voltage and load input current as a percentage of rating current/voltage. Where 0 volts = 0% rating and 10 volts = 100% load input rating voltage or current.

The voltage monitor output is across pins 1 & 3, and the current monitor output is across pins 1 & 2. Pin 6 outputs a +15V reference voltage.

Below shows the pin configuration of the voltage and current monitor outputs.

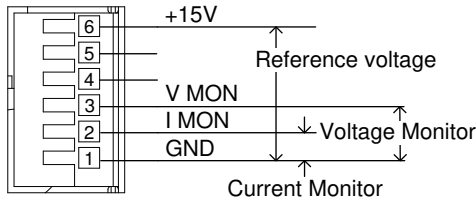

Connector Connection

The channel control connector is a screw less clamp connector. The internal clamp mechanism must be opened before a wire can be inserted. To open the internal clamp, push the button above the wire socket, to close, release the button. Ensure at least 10mm is striped from the wire. The diagram below shows the wire insertion procedure.

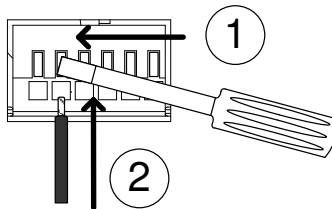

! WARNING

All connections to the channel control connector must use a 24 AWG wire gauge.

Go/NoGo Connection

Background

The Go/NoGo port is a 15 socket port. Each channel has a dedicated line for a Go/NoGo output. The ports are open-collector with active low (1.1V) indicating a pass and active high (30V) as fail (an alarm). The Go/NoGo terminal is a DB-15 female.

For more details on the Go/NoGo interface see page 274.

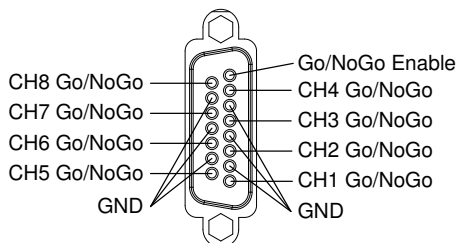

OPERATING DESCRIPTION

| | |
|----------------------------------|-----|
| Operating Mode Description | 64 |
| Constant Current Mode | 64 |
| Constant Resistance Mode..... | 67 |
| Constant Voltage Mode..... | 70 |
| Constant Power Mode..... | 73 |
| Parallel Unit Mode | 75 |
| Run Program..... | 77 |
| Sequence | 80 |
| OCP Test Automation | 85 |
| Parallel Dynamic Loading..... | 86 |
| Configurations Description | 87 |
| Protection Modes | 87 |
| Operating Configurations | 89 |
| Channel Control..... | 93 |
| Interface and File System | 97 |
| Interface | 97 |
| File System | 97 |
| File Format | 102 |

Operating Mode Description

There are four basic operating modes: constant current (CC), Constant Resistance (CR), Constant Voltage (CV/CV+CC) and Constant Power (CP). All channels operate using any of the modes. Each mode has a number of configurable options including slew rate, levels, protection modes, Go/NoGo and extensive save options.

Constant Current Mode

Background In Constant Current Mode the load units will sink the amount of current programmed. Regardless of the voltage, the current will stay the same. There are two ranges in CC mode: High and Low. There are two main modes in CC mode: Static and Dynamic. Static mode can be used for stability tests and dynamic mode can be used to test transient load conditions.

Go/NoGo is supported for both High and Low range as well as Static and Dynamic mode.

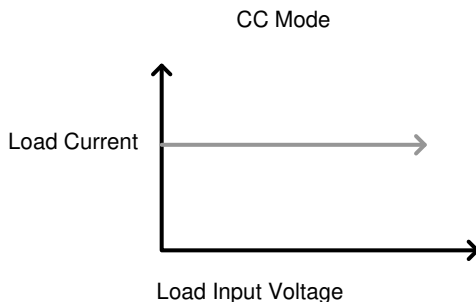

Range There are two selectable ranges for constant current mode: high and low range.

Low range has a higher resolution, but a lower range. If the current exceeds the Low Range, High range must be used.

Static Functions Static mode tests the stability of the voltage output from a power source. Single channel load modules can have two 2 current levels A (A Value) & B (B Value). A & B have the same range. Pressing the A/B key on the module load will cycle through the A and B states. Alternatively, the mainframe can select A or B Value.

Dual channel load modules only have one current level (A Value) per channel in static mode.

Static Mode:
Single Channel
Load module.

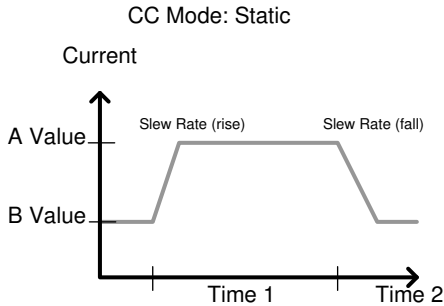

Dynamic Functions Dynamic load functions allow you to set load levels (Level1, Level2), load time (Timer1, Timer2), and the slew rate (rising, falling). Depending on the settings, the load will switch automatically between levels 1 and 2.

Dynamic loading can be used for charge discharge cycle testing etc.

CC Mode: Dynamic

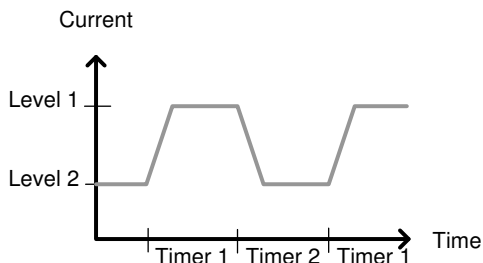

Slew rate

The slew rate is the rate at which the current will increase to a set level. There are two slew rates: rising slew rate & falling slew rate. In CC mode the slew rate is defined as A/uS.

Slew Rate

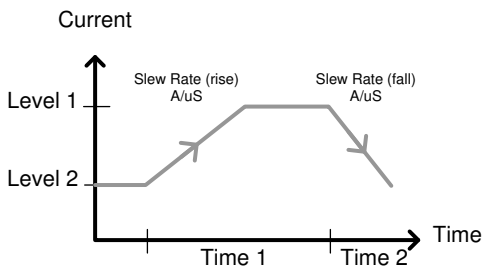

As can be seen above, the rising and falling slew rate need not be the same.

Go/NoGo

Using Go/NoGo, the Center, High and Low voltage limits can be set for both Static and Dynamic modes. A delay time of up to 1 second can also be set.

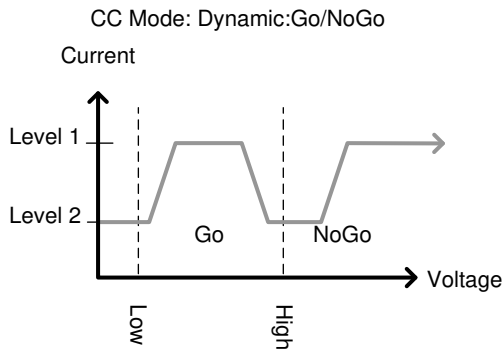
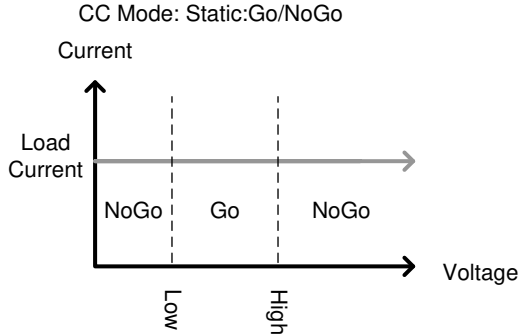

GO is specified as between the Low and High Go/NoGo limits. NoGo is specified as outside the Go/NoGo limits.

Constant Resistance Mode

Background

In Constant Resistance Mode the load units will linearly sink current and voltage to match a set resistance. CR mode has two different values (single load modules), two different ranges and rising and falling slew rates. Like CC mode, Constant resistance mode supports both dynamic and static loads. As with the other modes, Go/NoGo is supported.

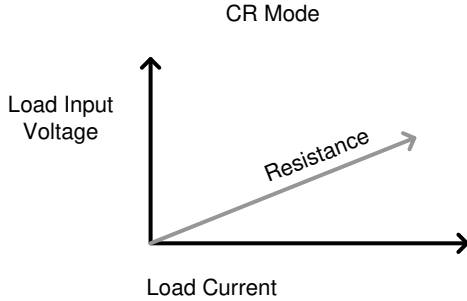

Resistance Range There are two ranges: High and Low. The Low range is used for low voltage ranges, whilst the High range uses high voltage ranges. The current range always remains in High range, regardless of the selected voltage range.

Static Functions A/B range For static mode, single channel load modules have two resistance levels, A & B Value. The A/B key can be used to switch between these resistance levels. Dual channel load modules only have one resistance level, A Value.

Single Load Module

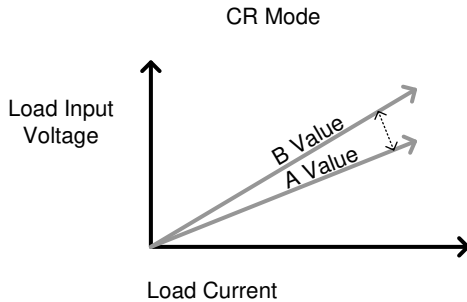

Dynamic Functions CR mode supports Dynamic loading. Dynamic load has two resistance levels (Level 1&2), and two timers (Timer 1&2) to switch between the resistance levels. Rising and falling slew rates can be set to determine the speed at which the load generator switches between load levels.

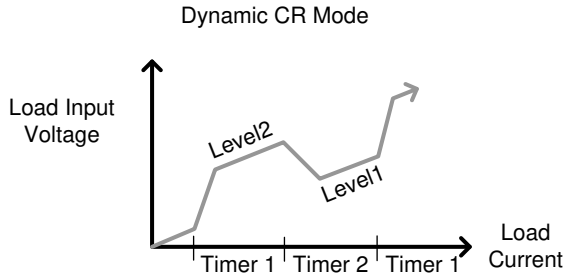

Slew Rate The rising and falling slew rate (A/uS) determines the speed at which the load levels change from A to B Value (Static mode) or from Level1 to 2 (Dynamic mode) and vice versa.

Go/NoGo Go/NoGo is also supported. Center, High and Low limits can be set as either percentages or voltage values. A delay time of up to 1 second can also be set.

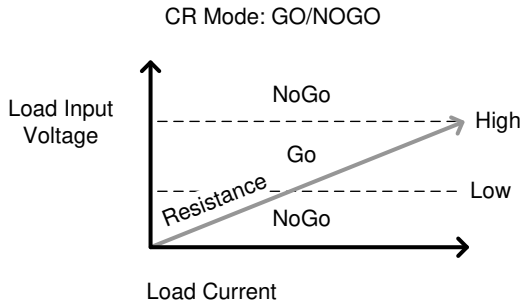

Constant Voltage Mode

Background In Constant Voltage Mode the load units will sink current whilst keeping the voltage constant.

Single channel load modules support 2 values (A Value, B Value) and have an adjustable cut-off current limit. Dual channel load modules only have A value.

Response speed can also be set to fast (Fast) or slow (Slow). The response speed relates to the slew rate of the current response.

Constant voltage mode only operates in high range.

Go/NoGo functionality is also supported either as a percentage or as a current value.

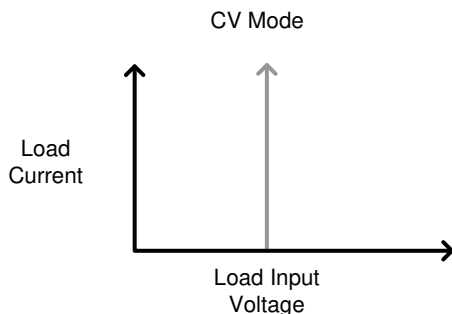

Voltage levels Two voltage levels can be set: A & B (single channel load module).

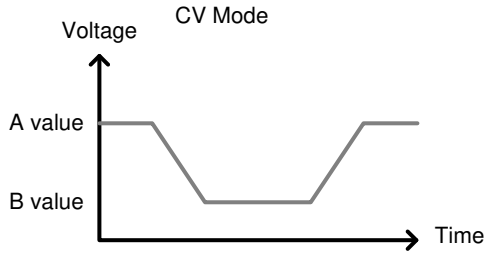

CV + CC

When using CV mode, a current limit can be set for CV + CC mode.

When the voltage input is greater than A Value (load voltage) then the channel will operate in CV mode if the input current is less than the current limit. When the input current exceeds the current limit, the channel will operate in CC mode.

When the voltage input is less than A Value (load voltage) current stops flowing.

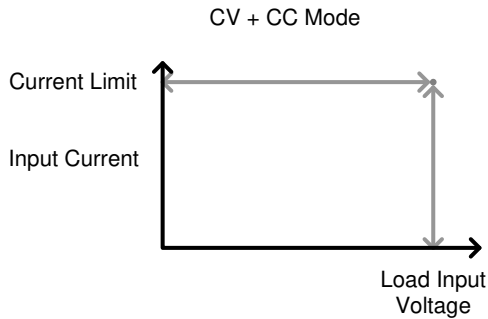

Response Speed Response speed can be set to fast or slow. Fast response and slow response is determined by the load module specifications. Slow response speeds are suitable for large loads as quick current changes will induce induction which can cause large voltage drops. The PEL series will try to rectify any voltage drops. However if voltage drops are too large, they may cause the load generator to go into oscillation. Large voltage drops caused by line voltage induction may damage the machine.

| Range | Fast | Slow |
|-------|------|-------|
| | 1kHz | 100Hz |

Go/NoGo Go/NoGo testing can be with either current (Ampere) values (High, Low) or percentage values (Center, High %, Low %). A delay time of up to 1 second can also be set.

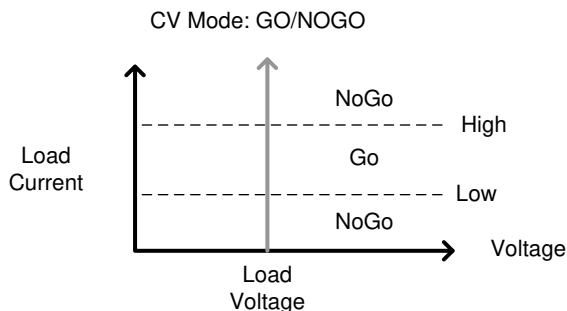

Constant Power Mode

Background In Constant Power Mode the load units will ensure a constant power load for the power supply.

Single channel load modules support 2 values (A Value, B Value) and have an adjustable cut-off current limit. Dual channel load modules only have A value.

Constant power mode can operate in high or low range.

Go/NoGo functionality is also supported either as a percentage or as a current value.

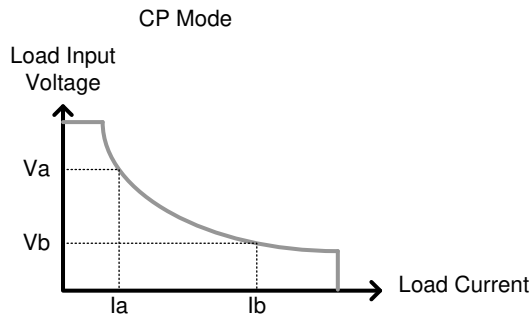

Power levels Two power levels can be set: A & B (single channel load module).

CP Mode

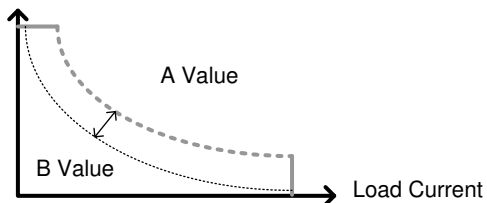

High/Low Range There are two ranges: High and Low. The Low range is used for low power ranges, whilst the High range uses high power ranges.

CP Mode

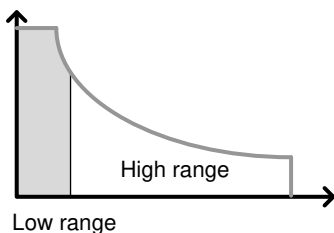

Go/NoGo Go/NoGo testing can set High and Low Current limits as a Value (in Amperes) or as a percentage. A delay time of up to 1 second can also be set.

CP Mode

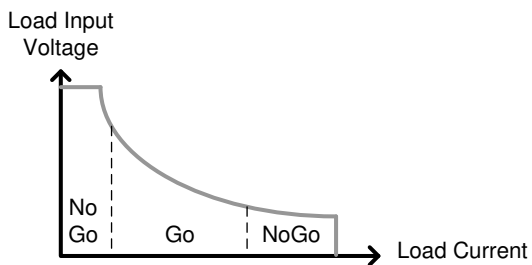

Parallel Unit Mode

| | |
|---------------|--|
| Background | <p>The Parallel configuration menu allows load modules of the same type and rating to be configured as a single unit when used in parallel. This saves the hassle of configuring each channel individually.</p> <p>Parallel Configuration is only supported under CC and CR mode.</p> <p>Parallel Configuration has three configuration settings: Parallel Unit, Parallel Mode and Display Mode.</p> |
| Parallel Unit | <p>This configuration setting sets the number units that are to be used in parallel and enables or disables the Parallel Unit mode.</p> |
| Parallel Mode | <p>The Parallel Mode setting determines how the Current Levels/Resistance Values are set when used in parallel. There are two settings: Para and Sync.</p> <p>The Para setting allows the all the parallelized load modules to be operated as a single large load module.</p> <p>Sync mode allows the settings of a single unit to be synchronized across all the other parallelized load modules.</p> |

CC Example Consider 3 load modules set to CC mode in Parallel.

In CC mode the total current for all units is the sum of each unit.

$$\text{Total } I = I_1 + I_2 + I_n$$

For example, to set a total load current of 90A, the Current Level setting in Para mode would be 90A, whilst it would be 30A in Sync mode.

Para mode

Sync Mode

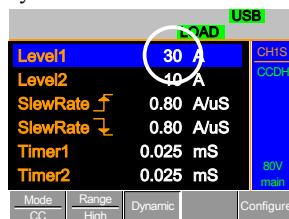
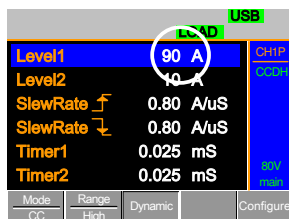

CR Example When used in CR mode, the equation for equivalent resistance for all the parallel loads is:

$$\frac{1}{R_{e q}} = \frac{1}{R_1} + \frac{1}{R_2} + \frac{1}{R_n}$$

For example, if 2 load modules have a set resistance of 100Ω each, the equivalent resistance of the load modules would be 50Ω. The Level setting in Para mode would be 50Ω and 100Ω in Sync mode.

Para mode

Sync Mode

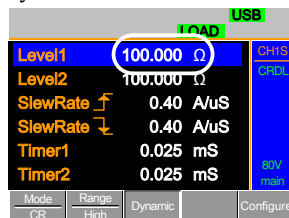
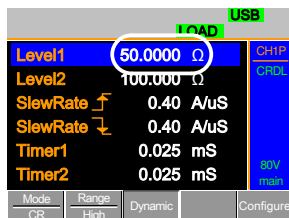

Display Mode Display mode determines what units are displayed on the local load modules: V/I, V/W, I/W, S. The displayed units can only be controlled through this menu.

Run Program

Background The Program function on the PEL-2000A series supports a total of 12 different programs at any one time with 10 sequences to each program. Up to 12 programs can be chained together. The Program function is able to create a number of Go/NoGo tests.

Run Program is not supported in Parallel Mode (page 75).

Program Sequence A program sequence is simply a single load test. A program is a battery of each of these tests run in succession. Each sequence loads the settings for each channel from Memory Data (Memory MXXX). The Memory Data stores settings such as the operating mode and range for each channel. Each sequence loads all channels at the same time, unless programmed otherwise. Sequences for each channel run synchronously.

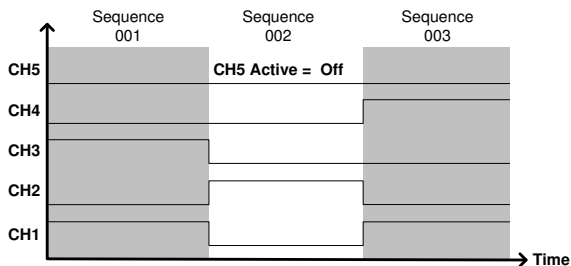

Each Sequence has a number of configuration options that apply to all the channels equally.

| Sequence Item | Description |
|---------------|--|
| Memory | Loads the channel settings for each load module Range: M001~M120 |
| Run | Sets the running configuration for the current sequence. The sequence can be skipped, run or run manually only. Range: Auto Skip Manual |
| On-Time | Sets the Sequence Run On-Time Range: 0.1 ~ 60.0s |
| Off-Time | Sets the Sequence Off-Time Range: Off 0.1 ~ 60.0s |
| Short-time | Sets whether the Short-Time for the sequence. Range: Off 0.1s ~ On-time |
| P/F-Time | Sets the Pass/Fail time for the sequence Range: Off 0.1 ~ (On-Time+Off-Time)-0.1s |
| Short Channel | Selects which channel will be shorted during the sequence Range: CH1 ~ CH8 |

Program

Sequences are run sequentially to create a Program. There are 10 Sequences in each Program.



If less than 10 Sequences are desired for a Program, any additional Sequences can be skipped (not run).

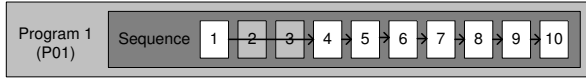

Sequence 2 & 3 are skipped.

Program Chain

Any of the 12 programs can be chained together to create a Program Chain. Unlike Program Sequences, Program Chains need not be run sequentially in numerical order. Any program can be chained to any program. It is possible to chain programs into an infinite loop to continue a program indefinitely.

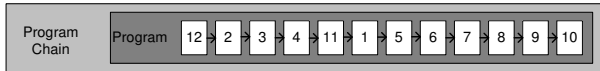

Above, a program chain running sequences out-of-order.

Go/NoGo Results If Go/NoGo limits have been configured, the Pass/Fail results for each channel will be displayed for all the sequences and programs.

PROG

Channel

| Program no. | P | S | 1 | 2 |
|--------------|---|---|---|---|
| Sequence no. | 1 | 1 | G | N |
| Channel | 1 | 2 | G | N |
| | 1 | 3 | G | N |
| | 1 | 4 | G | G |

Go/NoGo

Exit

Sequence

Background The Sequence function is used to create high resolution load simulations. Each Sequence can be configured to create a unique load profile to accurately simulate loads in real time. Sequences are only applicable for CC (Static) and CR (Static) modes.



Note: Sequences are not to be confused with the sequences used to create a program. They are not the same and cannot be used interchangeably. Sequences (SEQ memory) cannot be used in Programs and Programs cannot load Sequences.

Load Profiling The Sequence function is able to simulate a load to a high resolution. Each channel is able to change its load sink within 100us per point independently. When used in parallel, multiple loads can be sunk concurrently to simulate the loads placed on multiple output power sources.

The diagram below shows the load profile of a DUT at start-up.

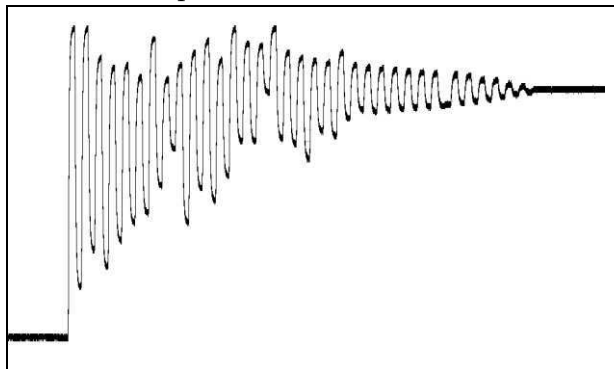

Points

Up to 120 points can be used with each Sequence. Each point can have a different duration, slew rate and value.

A new point can be inserted or deleted at any stage of a Sequence. Any new points that are inserted will have a value averaged from its neighbors as default.

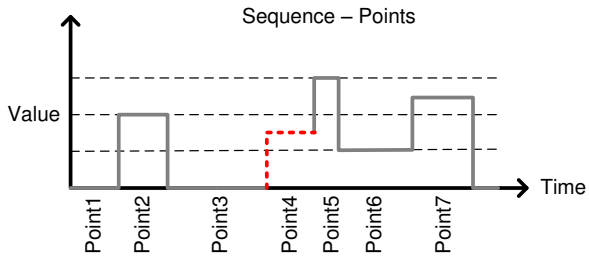

A new point is inserted after Point 3.

Loop

Sequences can be programmed to loop a number of times starting from any point in the sequence.

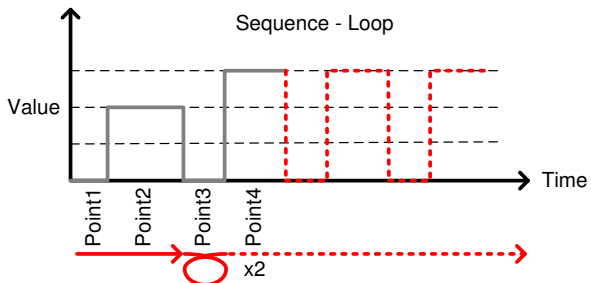

From Point3 the sequence is looped two times.

On End Of Seq. function If more than one Sequence is programmed on the mainframe, the On End Of Seq. function will hold the load current (of the selected sequence) to a designated value until all the other sequences have finished running.

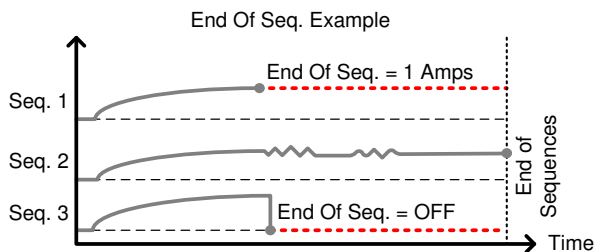

In the example above, Seq. 1 will hold the load current at 1A at the end of its sequence until the last sequence has finished. Seq. 2 is the longest sequence, and as such the End Of Seq. setting is not applicable. Seq. 3 is turned off after its sequence has finished (0 amps).

Trig Out The Trigger Out function allows a trigger sequence signal to be output from a channel via PIN 4 on Frame Link connector 1 when using Sequences. The Trig Out function is used from the Channel Duration menu.

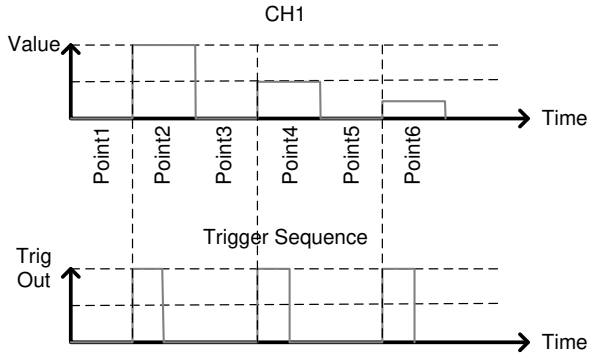

As can be seen above, a trigger sequence signal is output for every rising edge point.

Trig In The Trigger In setting allows a sequence to start after a trigger (Trig Out) has been received via the frame link connector. The Trig In setting is used for frame linked mainframes.

Channel Duration Time Setting The Channel Duration Time Setting feature allows the point time duration of one Sequence to be imported by another Sequence. If the receiving sequence doesn't have enough points, more will be created (without values).

For example, the sequences for CH1 and CH2 are shown below. CH1 has a total of 6 points with long durations, whilst CH2 has only 2 points, looped 5 times. The points from CH2 are also significantly shorter in duration.

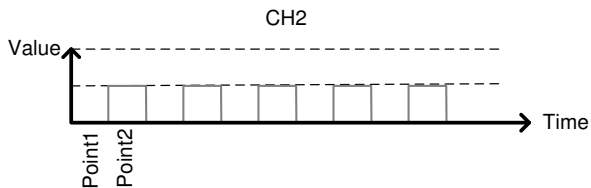
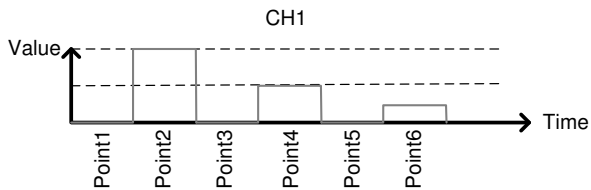

Below shows the resulting sequence when CH1 imports CH2. CH1 imports the duration time settings and number of points from CH2, but not the value data.

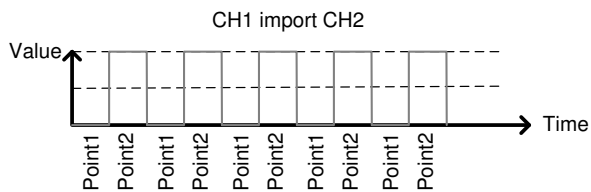

OCP Test Automation

Background The OCP test function creates an automatic test to test the over current protection of power supply products. See page 179 for operation details.

This test will test to see when the over current protection of a power supply is tripped and return the measurements for the voltage and current when the over current protection was tripped. The PEL-2000A also has a user-defined OCP setting in the event that the power supply OCP fails.

The diagram below shows an example of the OCP Test Automation function.

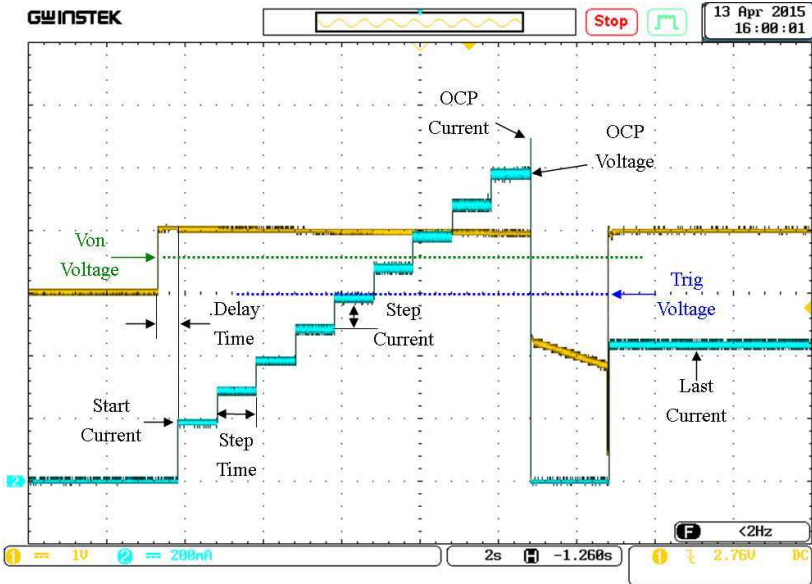

Parallel Dynamic Loading

Background

The PEL-2000A series of DC electronic loads support parallel dynamic loading. This simply means that when the load modules of a mainframe are connected in parallel and set to dynamic mode, they can perform dynamic tests synchronously following the same clock. Under dynamic mode, load current or resistance is pulsed between two preset levels. When used in parallel, higher powered outputs can be tested. This ability gives the PEL-2000A series the flexibility to perform dynamic tests over a wide range of power outputs.

For connection details see the Parallel Load Connections section on page 54.

The diagram below shows how two load modules are able to sink a higher load when used in parallel under dynamic mode.

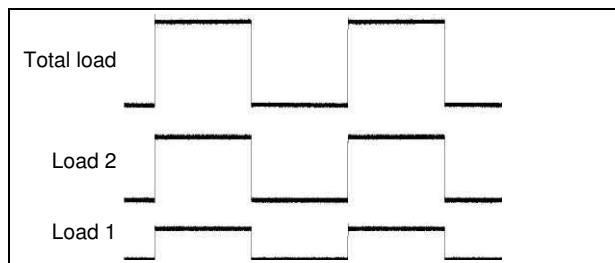

Note

Note: The same type of load modules must be used operated in parallel.

Configurations Description

There are a number of different configurations for the PEL series including protection modes, operating configurations, and file system configurations. The Configuration Description section describes what the different configurations are used for and how they can be relevant to different operations.

Protection Modes

Background The PEL-2000A series include a number of protection modes: Over Current Protection, Over Voltage Protection, Over Power Protection, Under voltage protection and Constant Power Protection.

The protection modes are useful to protect both the load modules and the DUT(s). A buzzer can be set to notify when a protection setting has been tripped. When a protection feature is activated and has been tripped then the load unit will display an alarm. The Mainframe will also display an alarm. When an alarm has been tripped the load will stop sinking current/voltage. There are three Over load protection settings: ON, OFF and Clear.

| | | Alarm |
|--------------------|---------|---------------|
| OCP Level | 5.075 A | CH1 |
| OCP Setting | OFF | CCDH |
| OVP Level | 81.6 V | |
| OVP Setting | ON | |
| OPP Level | 29.75 W | |
| OPP Setting | OFF | 80V Cont |
| Protection | Other | Go-NoGo |
| | | Previous Menu |

Over Current Protection

When a load unit is operating in CR, CV or CP mode, the unit may need over current protection to prevent excessive current being sunk. Over current protection stops the load from sinking more current than its recommended limit which can cause damage to the unit.

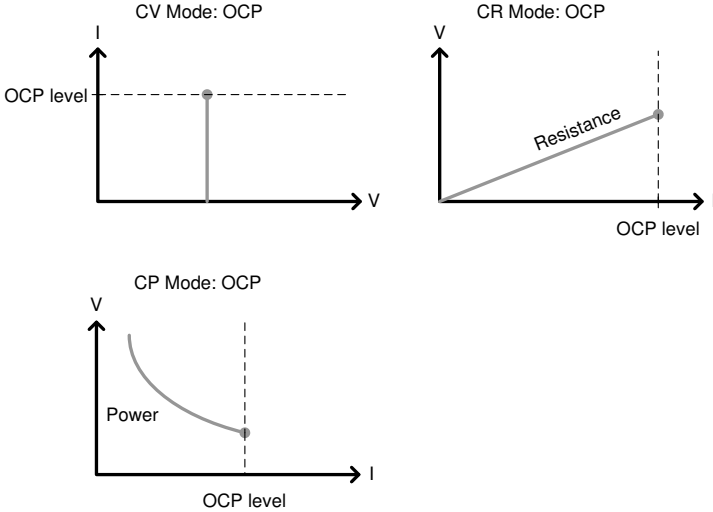

Over Voltage Protection

Over voltage protection is used to limit the amount of voltage sunk. If the OVP trips, the PEL series load will stop sinking voltage.

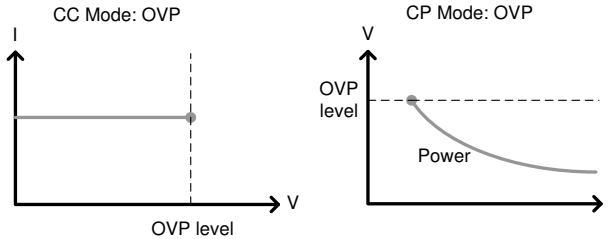

| | |
|----------------------------|---|
| Over Power Protection | Over power protection is used when the power range exceeds the specifications of the load. When OPP is tripped power will cease to be sunk. |
| Reverse voltage Protection | Reverse voltage protection prevents reverse voltage damage to the PEL-2000A series up to the specified rating. When Reverse voltage protection has been tripped an alarm tone will sound until the reverse voltage is removed. For more details please see the specifications. |
| Under voltage Protection | Under voltage protection will turn off the load when the voltage drops below a set limit. |
| Constant Power Protection | Constant power protection will prevent excessive power draw. |

Operating Configurations

| | |
|------------|--|
| Background | There are number of operating configuration settings. Configuration settings are for the following: CC Vrange, Von Voltage, Von Latch, Short Key, CH Cont, Independent load sync, D-time, Step resolution settings and Response settings. |
| CC Vrange | CC Vrange (page 192) is used to set the voltage range as High or Low for CC mode. CC voltage range is dependent on the load module specifications. |

Von Voltage

Von Voltage is the voltage limit at which the load will start to sink current. There are two operation modes for Von Voltage: Von latched: ON and Von latched: OFF.

Latched: ON will sink current when Von has been tripped, and will continue to sink current even if the voltage drops below the Von Voltage.

Von Latched: OFF will sink current when Von has been tripped, but will stop sinking current when the voltage drops below the Von Voltage setting.

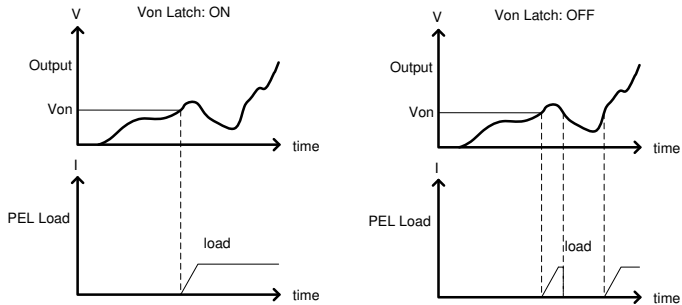

As can be seen in the diagram below, when Von-Latch is set to off, the load module will start to sink current when the Von-voltage limit has been tripped. It will stop sinking current when the output drops below the Von voltage limit.

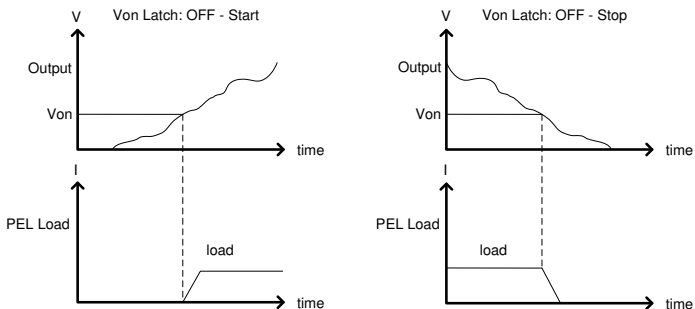

Short When short mode is on, the load unit can simulate a short circuit.

Shorting can be individually set for each channel when programming sequences.

To initiate a short circuit manually, the short key is used. It can be used at any time during an operation. It will not affect the settings. After a short circuit has finished, the load unit will resume the previous operation.

The short key can be set to toggle or hold. When pressed in toggle mode, shorts are toggled on and off. When pressed in hold mode, the key needs to be held to short the load.



A short circuit may trip a protection mode if too much current is sunk.

CH CONT Channel Control. When Channel control is activated (External) it can be used to monitor the voltage and current output of the load as well as turn loads on or off remotely from the Channel Control (CH CONT) connectors located on the rear panel.

For more information about channel control, see external voltage control on page 93.

Independent The Independent setting will allow the load modules to be controlled independently from the mainframe.

Load D-Time Load Delay time is used to delay activating a load (up to 10 seconds) after the load key has been pressed. However the Load D-Time setting will only work for loads that are initiated manually or when the PEL series mainframe is configured to Auto load (page 217) at run time.

Step Resolution Each channel voltage, current and resistance setting can have the step resolution configured. The step resolution refers to the step resolution of the *coarse adjustment* of these settings. The *fine adjustment* cannot be configured, see page 202 for details.

For example if the step resolution for CCH (CC high range) is .5 A, then the resolution can be incremented in .5A steps;

$$8.0 \leftarrow \rightarrow 8.5 \leftarrow \rightarrow 9.0 \leftarrow \rightarrow 9.5$$

The step resolution parameters apply to the following:

- CCH Step – CC high range
- CCL Step – CC low range
- CRH Step – CR high range
- CRL Step – CR low range
- CV Step – CV high range

Step Resolution Range The step resolution range is dependent on the load module and the range:

Max resolution: Module dependant, see page 202

Min resolution: Channel range/2

Response The Response setting sets the bandwidth of the load generator to 100kHz(normal) or 1MHz(fast). The Response setting is particularly important for limiting startup current.

Channel Control

Background External channel control is used with the Channel Control connectors. Each channel control connector can activate each load, monitor voltage and current and has an external voltage reference input. The voltage and current monitors output 0~100% of the rated current/voltage as a voltage of 0~10V.

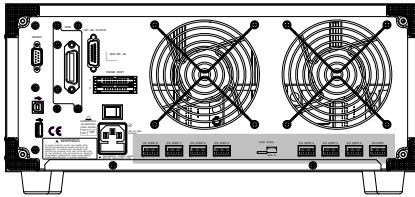

External Voltage Reference A voltage reference of 0-10V is used to represent 0-100% of the rating voltage/current of a load module. As seen below the external voltage reference and the rating voltage/current have a linear relationship. By varying the reference voltage between 0~10V the voltage/current setting will be changed accordingly.

External Voltage Control

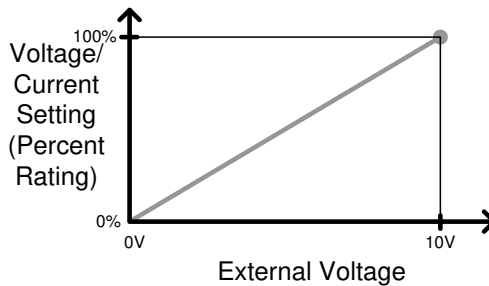

To determine the Percent Rating (voltage or current load input), use the following formula;

$$Load\ Input = \frac{External\ Voltage}{10(V)} \times Rating\ VorA$$

Where "Rating V or A" is the rating voltage/current of the load module.

Current Monitor The load current input can be externally monitored using the IMON pin of a channel control connector. The IMON pin outputs a voltage of 0~10V to represent the input current as a percentage (0~100%) of rating current.

Current Monitor

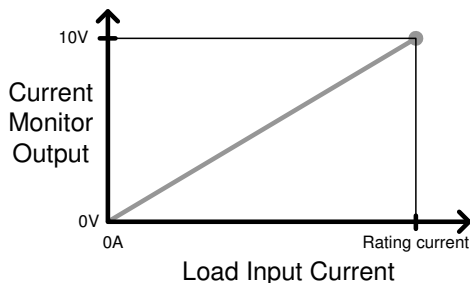

To determine the Current Monitor Output (IMON) , use the following formula;

$$IMON = \frac{Load\ input\ current}{Rating\ A} \times 10V$$

Where "Rating A" is the rating current of the load module.

Voltage Monitor The input voltage, like the load input current can be externally monitored with the channel control connectors. The VMON pin of the channel control connector outputs a voltage of 0~10V to represent the load input voltage as a percentage (0~100%) of the rating voltage.

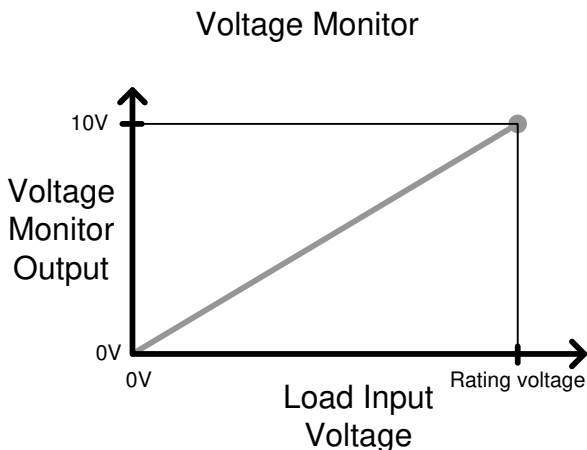

To determine the Voltage Monitor Output (VMON) , use the following formula;

$$VMON = \frac{\text{Load input voltage}}{\text{Rating V}} \times 10V$$

Where “Rating V” is the rating voltage of the load module.

Turning on the Load A load is turned on when Load On input is set to On (active low). A load is turned off when the Load On input is set to Off (active high).

When a load is turned on from the channel control interface, the load can be turned off from the mainframe, local module and via remote control. However the opposite is not true; when a load is turned off using the channel control interface, the load cannot be turned on via the mainframe, local module or via remote control.

For connections and configurations, see pages 59 and 270 respectively.

Interface and File System

Interface

Background The PEL-2000A series support RS232, GPIB and USB remote frame control. Only one type of connection is supported at any one time. For more information on remote control please see the GW Instek website at www.gwinstek.com or see your local distributor about the PEL-2000A programming manual.

For connection options and configurations see the options below.

| | |
|-------------------------|----------|
| RS-232 configuration. | Page 231 |
| RS-232 pin connection. | Page 268 |
| GPIB configuration. | Page 233 |
| GPIB pin configuration. | Page 269 |
| USB configuration. | Page 234 |

File System

Background The PEL series is able to save and recall a number of different data types for each channel:
Presets
Memory
Setup
SEQ (Sequence)

All data types can be saved and recalled to internal memory or saved to a USB flash drive. Each channel has its own dedicated memory for each

data type. Thus files are saved/recalled for each channel and each data type.

Preset Data Preset data can be saved into 10 memory slots for each channel. Preset data contains the mode, range, CV response speed and Go/NoGo settings.

Internal Format P0~P9

External Format 20X0X_XX.P

Preset Contents Preset data contains the following data;

- | | | |
|---------|---|---|
| CHAN | <ul style="list-style-type: none"> • Mode • Range | <ul style="list-style-type: none"> • Static/Dynamic • CV response speed |
| Go/NoGo | <ul style="list-style-type: none"> • SPEC Test • High • Center | <ul style="list-style-type: none"> • Entry Mode • Low |

Memory Data Each channel can save up to 120 different Memory data types (M001~M120) into internal memory. Memory data contains general channel settings and is used when programming sequences. Memory data can be stored both internally and externally to USB. Preset data and Memory data store the same contents.

Internal Format M001~M120

External Format 20X0X_XX.M

Memory Contents Memory data contains the following data;

- | | | |
|---------|---|---|
| CHAN | <ul style="list-style-type: none"> • Mode • Range | <ul style="list-style-type: none"> • Static/Dynamic • CV response speed |
| Go/NoGo | <ul style="list-style-type: none"> • SPEC Test • High • Center | <ul style="list-style-type: none"> • Entry Mode • Low |

| | | | | | | | |
|-----------------|---|---|--|---|------------|---|--|
| SEQ Data | SEQ data contains Sequence data. SEQ data can only be saved to and from USB. SEQ refers to Sequence data, not Program sequences. | | | | | | |
| | <table border="0"> <tr> <td data-bbox="369 311 672 359">Internal Format</td> <td data-bbox="672 311 993 359">N/A (Internal buffer)</td> </tr> <tr> <td data-bbox="369 359 672 406">External Format</td> <td data-bbox="672 359 993 406">20X0X_XX.A</td> </tr> </table> | Internal Format | N/A (Internal buffer) | External Format | 20X0X_XX.A | | |
| Internal Format | N/A (Internal buffer) | | | | | | |
| External Format | 20X0X_XX.A | | | | | | |
| SEQ Contents | <p data-bbox="369 406 993 470">SEQ data contains the following data;</p> <table border="0"> <tr> <td data-bbox="369 470 504 614">Seq.Edit</td> <td data-bbox="504 470 728 614"> <ul style="list-style-type: none"> • No. (Points) • Slew rate f • Duration time </td> <td data-bbox="728 470 993 614"> <ul style="list-style-type: none"> • Value • Slew rate \bar{f} </td> </tr> <tr> <td data-bbox="369 614 504 694">Loop</td> <td data-bbox="504 614 728 694"> <ul style="list-style-type: none"> • Repeat • On End Load </td> <td data-bbox="728 614 993 694"> <ul style="list-style-type: none"> • Start of Loop • CC Vrange </td> </tr> </table> | Seq.Edit | <ul style="list-style-type: none"> • No. (Points) • Slew rate f • Duration time | <ul style="list-style-type: none"> • Value • Slew rate \bar{f} | Loop | <ul style="list-style-type: none"> • Repeat • On End Load | <ul style="list-style-type: none"> • Start of Loop • CC Vrange |
| Seq.Edit | <ul style="list-style-type: none"> • No. (Points) • Slew rate f • Duration time | <ul style="list-style-type: none"> • Value • Slew rate \bar{f} | | | | | |
| Loop | <ul style="list-style-type: none"> • Repeat • On End Load | <ul style="list-style-type: none"> • Start of Loop • CC Vrange | | | | | |
| Setup Data | <p data-bbox="369 694 993 893">Setup data can be saved to 4 internal memory slots. Setup data contains Memory data, Program Sequence, Chain data, configuration settings and operation settings for every channel. Setup data can be saved to Internal memory or to USB.</p> <table border="0"> <tr> <td data-bbox="369 893 672 941">Internal Format</td> <td data-bbox="672 893 993 941">Setup Memory 1~4</td> </tr> <tr> <td data-bbox="369 941 672 989">External Format</td> <td data-bbox="672 941 993 989">200X0_XX.S</td> </tr> </table> | Internal Format | Setup Memory 1~4 | External Format | 200X0_XX.S | | |
| Internal Format | Setup Memory 1~4 | | | | | | |
| External Format | 200X0_XX.S | | | | | | |
| Setup Contents | <p data-bbox="369 989 993 1053">Setup data contains the following data;</p> <table border="0"> <tr> <td data-bbox="369 1053 504 1308">Program</td> <td data-bbox="504 1053 728 1308"> <ul style="list-style-type: none"> • PROG • Memory • On-Time • P/F-Time • Short Channel </td> <td data-bbox="728 1053 993 1308"> <ul style="list-style-type: none"> • SEQ (program sequence no.) • Run • Off-Time • Short-Time </td> </tr> <tr> <td data-bbox="369 1308 504 1401">Chain</td> <td data-bbox="504 1308 728 1401"> <ul style="list-style-type: none"> • Start </td> <td data-bbox="728 1308 993 1401"> <ul style="list-style-type: none"> • Program Sequence (P01~P12) </td> </tr> </table> | Program | <ul style="list-style-type: none"> • PROG • Memory • On-Time • P/F-Time • Short Channel | <ul style="list-style-type: none"> • SEQ (program sequence no.) • Run • Off-Time • Short-Time | Chain | <ul style="list-style-type: none"> • Start | <ul style="list-style-type: none"> • Program Sequence (P01~P12) |
| Program | <ul style="list-style-type: none"> • PROG • Memory • On-Time • P/F-Time • Short Channel | <ul style="list-style-type: none"> • SEQ (program sequence no.) • Run • Off-Time • Short-Time | | | | | |
| Chain | <ul style="list-style-type: none"> • Start | <ul style="list-style-type: none"> • Program Sequence (P01~P12) | | | | | |

- | | | |
|---------|----------------------------|---------------------|
| Run | • Active Channel (CH01~08) | |
| CHAN | • Mode | • Static/Dynamic |
| | • Range | • CV response speed |
| Go/NoGo | • SPEC Test | • Entry Mode |
| | • High | • Low |
| | • Center | |

Save: Internal memory

When saving data to internal memory, either the current channel or all the channel data can be saved. Not all data types can save the current channel or all the channel data.

| Data Type | Current Ch | All Ch |
|-----------|-----------------|--------|
| Preset | ✓ | ✓ |
| Memory | ✓ | — |
| SEQ | ✓ (single save) | ✓ |
| Setup | — | ✓ |

Save: External memory

Only SEQ, Memory and Preset data can be saved for a single channel to USB. All four data types (SEQ, Memory, Setup, Preset) can save all channels to USB.

| Data Type | Current Ch | All Ch |
|-----------|------------|--------|
| Preset | ✓ | ✓ |
| Memory | ✓ | ✓ |
| SEQ | ✓ | ✓ |
| Setup | — | ✓ |

Save/Recall USB In order to save data from a single channel to USB, data must first be saved to the internal memory. After data is saved to internal memory, all the files can be saved to USB.

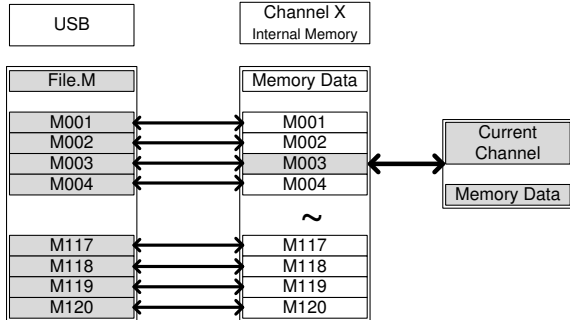

To recall saved files, the reverse is also true. Files must be recalled from the USB flash drive to internal memory. Then from internal memory the data can be recalled to each channel*.

*Excluding SEQ data.

Save/Recall All The SEQ, Preset, Memory or Setup data can be saved from every channel into USB. SEQ, Preset and Memory data is saved into a directory (ALL0000-ALL0099) with a file for each channel, whilst Setup data is saved in a single file.

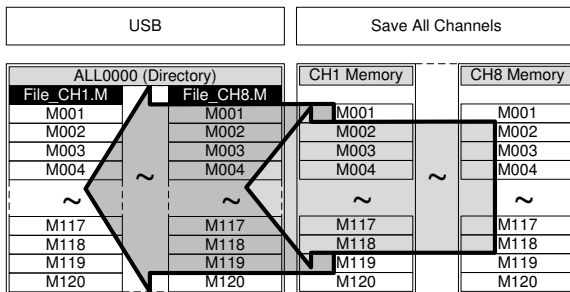

To recall saved files, the reverse is not true. Files must be recalled to each channel separately.

File Format

Single Channel

Filename format

Memory data
Preset data
SEQ data

2030R_00.M

1: PEL series Load module type:

2020 = PEL-2020A

2030 = PEL-2030A

2040 = PEL-2040A

2041 = PEL-2041A

2: Channel

R = Right

L = Left

0 = Single channel or not used

3: Save file number:

0 ~99

Incremented after each consecutive save.

4: File extension

M = Memory data

P = Preset data

A= SEQ data

All Channel

Directory Format

ALL_0000

- 1: All Channel common directory name
- 2: Directory number:
0000 ~ 0099

All Channel

File Format

Memory data
 Preset data
 SEQ data
 Setup Data

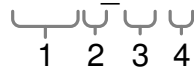
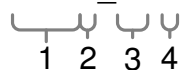
2030R_C1.M

 20040_00.S

- 1: PEL series Load module type:
 - 2020 = PEL-2020A
 - 2030 = PEL-2030A
 - 2040 = PEL-2040A
 - 2041 = PEL-2041A
- 2: Channel
 - R = Right
 - L = Left
 - 0 = Single channel
- 3: Channel number:
 - C1 = CH1
 - C2 = CH2
 - Etc.
 - 00 = All channels (Setup data)
- 4: File extension
 - M = Memory data
 - P = Preset data
 - A = SEQ data
 - S = Setup data

TUTORIALS

(Step by Step Operations)

| | |
|------------------------------------|-----|
| Local loads..... | 105 |
| Single Channel Load..... | 107 |
| Parallel Load Modules | 109 |
| Programming | 111 |
| Sequences..... | 113 |
| Frame Link | 114 |
| Channel Control | 116 |
| General Configuration Options..... | 118 |

Local loads

Local mode operation is useful to quickly test loads using the load module control panel rather than the mainframe control panel. Local load modules can be configured to operate independently to the mainframe. This can be useful when settings need to remain unchanged on the mainframe. Note however that the local modules cannot change the modes (CC, CV, CR, CP), only the values.

Parallel Unit mode is not supported for local module control.

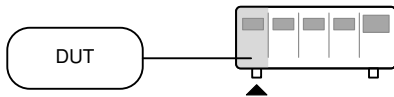

| Step | Description | Details |
|-------------------------------|--|--|
| 1. Setup | Ensure the channel load is set up as desired. | Pages 37, 45 |
| 2. Channel selection | Ensure the correct channel or Value (A/B) is selected by using the R/L or A/B key. | Page 124 |
| 3. Measurement Mode selection | If in CC or CR mode, Static or Dynamic mode can be selected. | CC Pages 125, 137 CR Pages 142, 145 |
| 4. Run the Load | Press the LOAD key to start/end loading the device under test. | Page 126 |

Optional

| | | |
|------------------------|---|----------|
| 5. Short configuration | Configure the SHORT key to hold/toggle short circuit configuration. | Page 127 |
| 6. Display | To change the display output, use the DISPLAY key. | Page 128 |
| 7. Shorting the load | To short the load, use the SHORT key when the load is on. | Page 127 |

- | | | |
|-----------------------------------|---|----------|
| 8. Independent load | The local load modules can be set to independent load. | Page 198 |
| 9. Independent control | Slave knobs can be configured to be independent to the mainframe. | Page 223 |
| 10. Configure Slave Knob Settings | Display Measured or Set Values with the selector knob. | Page 227 |
-

Single Channel Load

Single channel loads are used to manually test a DUT quickly or to configure channel settings for Program Sequences using the mainframe panel.

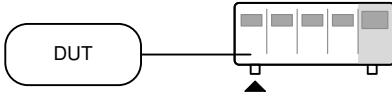

| Step | Description | Details |
|-------------------------------|--|--|
| 1. Setup | Choose the appropriate load module and make sure it is installed. | Page 37 |
| 2. Connection | Connect the terminals to the DUT. | Page 45 |
| 3. Channel selection | Select the load channel on the mainframe. | Page 130 |
| 4. Measurement mode selection | Select measurement mode (CC, CV, CR, CP). | CC Page 133 CV Page 148 CR Page 141 CP Page 152 |
| 5. Range selection | Set the range to high or low (CC, CR and CP mode). | CC Page 134 CR Page 141 CP Page 155 |
| 6. Mode selection | Choose Static or Dynamic mode (CC & CR mode only). | CC Pages 135, 137 CR Pages 142, 145 |
| 7. Dynamic levels (CC,CR) | Set the dynamic levels, slew rate and timers. Applicable to CC & CR mode only. | CC Page 135 CR Page 143 |
| 8. Static Values (CC,CV,CR) | Set the A(B) Value, slew rate (CC, CR) and current limit (CV, CP) | CC Page 138 CR Page 145 CV Page 149 CP Page 153 |

9. Go/NoGo Set the Go/NoGo configurations, Page 206
if applicable.

10. Protection Modes Configure the protection modes. Page 188

11. Run Activate the load by pressing the load key.



Optional

12. Configuration There are number of Page 118
configurations that apply to all
channels. For details see the
Configuration Tutorial.

Parallel Load Modules

The Parallel Unit configuration setting allows for a quick and easy parallel setup for load modules of the same type and rating. However, the Parallel Unit configuration settings only apply for CC and CR modes.

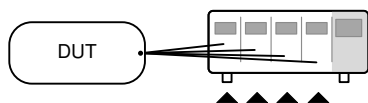

| Step | Description | Details |
|--------------------------------|---|--|
| 1. Setup | Choose the appropriate load modules and make sure they are installed. All load modules must be of the same type and rating. | Page 37 |
| 2. Connection | Connect the terminals to the DUT. | Page 45 |
| 3. Parallel mode configuration | Enable Parallel Unit Mode and configure. | Page 211 |
| 4. Measurement mode selection | Select measurement mode (CC, CR). | CC Page 133 CR Page 141 |
| 5. Range selection | Set the range to high or low (CC, CR mode). | CC Page 134 CR Page 141 |
| 6. Mode selection | Choose Static or Dynamic mode. | CC Pages 135, 137 CR Pages 142, 145 |
| 7. Dynamic levels | For Dynamic mode, set the dynamic levels, slew rate and timers. | CC Page 135 CR Page 143 |
| 8. Static Values | For Static mode, set the A(B) Value and slew rate. | CC Page 138 CR Page 145 |

9. Go/NoGo Set the Go/NoGo configurations, Page 206
if applicable.

10. Protection Modes Configure the protection modes. Page 188

11. Run Activate the load by pressing the load key.



Optional

12. Configuration There are number of configurations that apply to all channels. For details see the Configuration Tutorial. Page 118

Programming

When creating a Program Sequence or Chain, all channels are used at the same time unless programmed otherwise. Program Sequences use the channel settings stored from Memory Data. Program sequences are primarily used to perform a battery of pass/fail tests on DUTs.

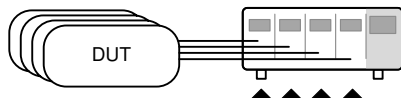

| Step | Description | Details |
|---------------------------|---|----------|
| 1. Setup | Choose the appropriate load module(s). | Page 37 |
| 2. Connection | Connect the terminals to the DUT. | Page 45 |
| 3. Channel selection | Select the load channel(s) on the mainframe. | Page 130 |
| 4. Channel setup | See the "Single channel load" tutorial to configure a single channel. Do not activate the load. | Page 107 |
| 5. Save channel | Save the configured channel. | Page 236 |
| 6. Multiple channels | If multiple channels need to be configured, follow steps 1-5 for any remaining channels. | |
| 7. Program menu | Enter the Program menu. | Page 152 |
| 8. Configure the sequence | Configure the first program. | |
| 9. Save sequences | Save the Program in the FUNC → Program menu. | |
| 10. Program Chains | If required, Program chains can be created. | Page 161 |
| 11. Save Program | Save the chain in the Chain menu. | |

| | | |
|----------------|---|----------|
| 12. Save Setup | Save everything to the internal Setup memory. | Page 241 |
| 13. Run | Run the Program Sequence/Chain. | Page 163 |

Sequences

Sequences are used to accurately simulate loads. As each Sequence is independent, Sequences are ideally suited to test multiple output power sources.

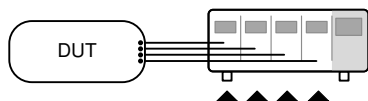

| Step | Description | Details |
|--------------------------|---|----------|
| 1. Setup | Choose the appropriate load module(s). | Page 37 |
| 2. Connection | Connect the terminals to the DUT. | Page 45 |
| 3. Channel selection | Select a load channel with the mainframe. | Page 130 |
| 4. Channel setup | Create a sequence. | Page 169 |
| 5. Sequence loop | Create a sequence loop if necessary. | Page 171 |
| 6. Multiple channels | If multiple channels need to be configured, follow steps 1-5 for any remaining channels. | |
| 7. Channel Duration menu | Edit the sequence channel duration information. Ensure that the channels containing Sequences are not set to OFF. | Page 174 |
| 8. Trigger Settings | Set Trigger Out and In channels, if appropriate. | |
| 9. Run | Run the Sequence(s) | Page 176 |

Frame Link

Frame link connections are used connect up to four slave main frames to a master main frame. When using frame link connections it is possible to perform a number of operations in parallel under the control of the master unit.

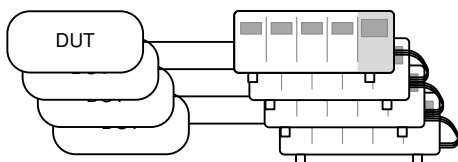

| Step | Description | Details |
|--------------|--|----------|
| 1. Setup | Connect the mainframes together. | Page 57 |
| 2. Configure | Configure the Frame CONT to ON for all mainframes. | Page 221 |



At first both the master and slaves are independent. FRM (Frame Master) can be seen on the top panel of the each mainframe. When a mainframe is connected as a slave unit, the FRM icon will change to FRS (Frame Slave). The front panel keys are disabled on slave units when in slave mode (FRS).

Slave mode **FRM** → **FRS**

Master/Independent **FRM**

| | | |
|------------|---|----------------|
| 3. Program | See the tutorial sections for programming or channel configuration. | Pages 107, 109 |
|------------|---|----------------|

4. Run Run the loads. To run the loads, press the LOAD key on the master mainframe. To stop, press again. When the LOAD key is pressed all loads will be active.

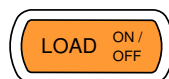

Options

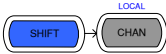
- | | | | |
|----|--------------------------|---|---|
| 5. | Load Preset memory | Load preset memory on the mainframe and all frame-linked slaves. | Page 265 |
| 6. | Load Setup Memory | Load setup memory on the mainframe and all frame-linked slaves | Page 264 |
| 7. | Set slave to independent | Press shift + CHAN on the slave unit to enable local control on a slave unit. |  |

FRS → **FRM**



Note

When a load is run or memory is recalled from the master mainframe, the slave unit will return to mainframe control.

Ensure the same firmware is installed on both master and slave mainframes.

Channel Control

The Channel Control connectors on the rear panel can be used to control and monitor the status of up to 8 channels. For more information on channel control, see page 93.

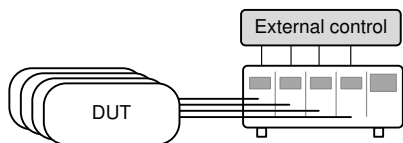

| Step | Description | Details |
|---------------|---|----------------------------------|
| 1. Setup | Ensure the load and PEL series mainframe is turned off. | |
| 2. | Choose the appropriate load module(s). | Page 37 |
| 3. Connection | Connect the terminals to the DUT. | Page 45 |
| 4. | Connect the channel control connectors on the rear panel. | Page 59 & 270 |
| 5. | Turn on the PEL series mainframe and DUT (load). | |
| 6. Configure | Select the Mode* and Range* via the front panel. | CC Pages 133, 134 CV Page 148 |
| 7. | Activate channel control for each channel that will be used for external control, i.e., set CH CONT to External. | Page 197 |
| 8. Run | Run the load. Turn the load on by either outputting an active low signal to the appropriate channel control connector or use the mainframe LOAD key*. | Page 59 & 93 |

9. Monitor Use IMON and VMON to monitor the current and voltage of load outputs. Page 93

10. End To turn the load off, output an active high signal to the channel control connector, or press the LOAD key on the load module or mainframe**.

* Mode and Range cannot be configured via the Channel Control (CH CONT) interface. Mode and Range can only be configured via the front panel.

** The LOAD key cannot always be used to turn on/off the load. See page 93 for details.

General Configuration Options

There are number of different options for each channel. The different options are described below.

| Options | Description | Details |
|-------------------------|--|----------|
| 1. CC Vrange | Configure the CC Voltage range from high or low. | Page 192 |
| 2. Von Voltage | Configure the Von Voltage settings. | Page 194 |
| 3. Short key | Configure the short key to toggle or hold. | Page 195 |
| 4. CH CONT | Turn channel control on/off | Page 197 |
| 5. Independent load | Turn the load module control to dependent (via mainframe) or independent control. | Page 198 |
| 6. Delay Time | Configure the load delay time for each channel. (0-10 seconds). | Page 200 |
| 7. Clear All Protection | Clear all the Protection Alarms. | Page 191 |
| 8. Display | Adjust display settings. | Page 218 |
| 9. Control type | Configure the Knob control. | Page 223 |
| 10. Slave Knob Setting | Display Measured or Set values with the selector knob. | Page 227 |
| 11. Alarm | Configure alarm settings. | Page 224 |
| 12. Step resolution | Configure the step resolution. Applicable to CC high and low range, CR high and low range and CV high range. | Page 202 |
| 13. Response | Configure the Response setting. | Page 206 |
| 14. Sound | Turn the sound on/off for the mainframe IU. | Page 218 |

O PERATION

The PEL series operation is described in the chapters below. The sections are broken down into small operations. For thorough examples on the operation of the load generator, please see the tutorial section on page 105.

| | |
|-------------------------------------|------------|
| Local Mode Operation | 123 |
| Selecting a Channel | 124 |
| Selecting Static/Dynamic | 125 |
| Turning on the Load | 126 |
| Shorting | 127 |
| Display Output View | 128 |
| Editing CC/CR/CV/CP A/B Value | 129 |

| | |
|--|------------|
| Mainframe Basic Operation | 130 |
| Help Menu | 131 |
| Channel Selection | 132 |
| Select CC Mode | 133 |
| Select CC Range | 134 |
| Select CC Dynamic Mode | 135 |
| Editing CC Dynamic Parameters | 135 |
| Select CC Static Mode | 137 |
| Editing CC Static Parameters | 138 |
| Set to CR Mode | 141 |
| Select CR Range | 141 |
| Select CR Dynamic Mode | 142 |
| Editing CR Dynamic Parameters | 143 |
| Select CR Static Mode | 145 |

| | |
|------------------------------------|-----|
| Editing CR Static Parameters | 145 |
| Select CV Mode..... | 148 |
| Editing CV Parameters | 149 |
| Select CV Response Speed | 151 |
| Select CP Mode..... | 152 |
| Editing CP Parameters | 153 |
| Select CP Range | 155 |

| | |
|--|------------|
| Creating a Program Sequence | 156 |
| Program Chains | 161 |
| Running a Program | 163 |

| | |
|--------------------------------------|------------|
| Edit Sequence | 169 |
| Create Sequence Loop..... | 172 |
| Channel Duration Time Settings | 174 |
| Run Sequence | 176 |

| | |
|----------------------------------|------------|
| OCP Test Automation | 179 |
|----------------------------------|------------|

| | |
|--|------------|
| Channel Configuration | 186 |
| Accessing the Configuration Menu..... | 187 |
| Setting (OCP/OVP/OPP/UVP) | 188 |
| Protection Clear | 191 |
| Setting the CC Voltage Range | 192 |
| Adjusting the Von Voltage and Latch .. | 194 |
| Configuring the Short key..... | 195 |
| Configuring Channel Control..... | 197 |
| Configuring the Independent Setting . | 198 |
| Configuring the Load Delay Time | 200 |
| Configuring Step Resolution | 202 |

| | |
|---------------------------------|-----|
| Configuring Response Time | 206 |
| Go/NoGo | 208 |
| Parallel Unit..... | 211 |
| View Parallel Information..... | 213 |

| | |
|--------------------------------------|------------|
| Mainframe Configuration | 215 |
| Accessing System Information | 216 |
| Accessing the Load Menu | 217 |
| Adjusting the Speaker | 218 |
| Adjusting the Display Settings | 219 |
| Adjusting the Frame Control | 221 |
| Adjusting the Knob Control Type..... | 223 |
| Configuring Alarm Sound..... | 224 |
| Configuring Go/NoGo Alarm Sound .. | 225 |
| Adjusting Slave Knob Settings | 227 |
| View Language Settings | 229 |

| | |
|--|------------|
| Interface Configuration (settings)..... | 230 |
| Configuring RS232 Connection | 231 |
| Configuring the GPIB Address | 233 |
| Configuring USB Remote Connection. | 234 |

| | |
|---|------------|
| Save / Recall | 236 |
| Saving/Recalling Channels..... | 237 |
| Saving/Recalling Preset memory..... | 239 |
| Saving/Recalling Setup Memory | 241 |
| Setting the Default USB Path/File | 243 |
| Saving Setups to USB Memory..... | 248 |
| Saving/Recalling Memory Data to USB251 | |
| Saving/Recalling Presets to USB | 255 |
| Saving/Recalling Sequences to USB... | 259 |

| | |
|--|-----|
| Quick Preset Recall/Save | 263 |
| Recall Setup Memory (Frame link). | 264 |
| Recall Preset Memory (Frame link) ... | 265 |
| Recall Factory Defaults | 266 |

Local Mode Operation

Each channel can be edited by its local load module. Depending on the configuration, local changes can be reflected on the mainframe. For this section all operations refer to knobs and buttons on the local load module panels, unless stated otherwise.

| | |
|-------------------------------------|------------|
| Local Mode Operation | 123 |
| Selecting a Channel | 124 |
| Selecting Static/Dynamic | 125 |
| Turning on the Load | 126 |
| Shorting | 127 |
| Display Output View | 128 |
| Editing CC/CR/CV/CP A/B Value | 129 |

Selecting a Channel

Background Each channel can be individually selected by using its load module panel. Changing channels on a load module only applies to dual channel load modules.

Single Channel Panel operation Press any key on a load module to select its channel.

Dual Channel Panel Operation For dual channel load modules, press any key on a load module that has the desired channel. Press the R/L key to cycle between the channels on the load module. L or R will be displayed on the bottom left hand to indicate which channel (left or right side) is active on the load module.



LR



On single channel modules, pressing the A/B key repeatedly will change the level from A or B when in Static mode.

Channels cannot be selected in Parallel Mode.

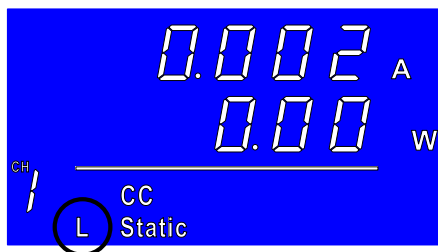

Selecting Static/Dynamic

Background Each load channel can be individually switched from Static to Dynamic using the local load module.

1. Select a channel on the load module. Page 124

Panel operation 2. Press the STATIC/DYNA. key to switch from dynamic to static mode and vice versa.

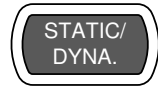

All changes will be shown on the display and depending on the configuration, reflected on the mainframe.

Static/Dynamic cannot be selected in Parallel mode.

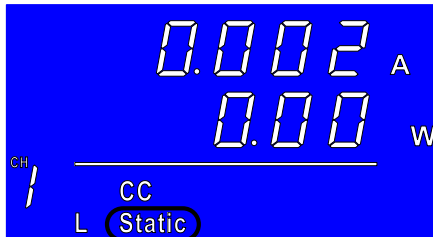

Turning on the Load

Background Loads can be individually selected to be turned on using local operation.

1. Select a channel on the load module. Page 124

Panel operation 2. Press the LOAD key to turn on the load.

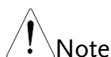

When a channel load is activated, the load on symbol will be displayed under the channel number.

Range

- L-ON** Left channel
- R-ON** Right channel
- ON** Single channel

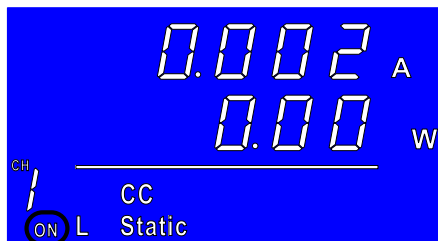

Turning the load off 3. Press the LOAD key.



Shorting

Background

The short key can be set to toggle or hold.

1. Ensure the load is off.
2. Select a channel on the load module.

Page 124

Panel operation

3. Press the SHORT key to change between shorting modes.



-hold- - When the load is on, the SHORT key needs to be held to short.

-to99- - When the load is on, the SHORT key can be used to toggle shorting on/off.

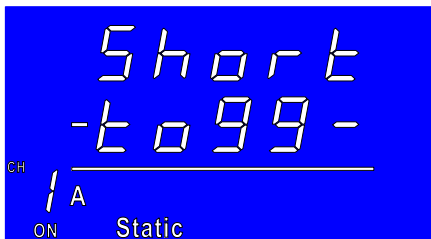
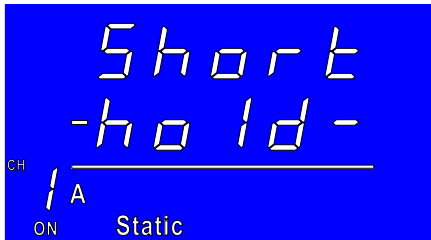

4. Press LOAD to turn on the load.



Shorting

5. a. Press the SHORT key (toggle mode).



Or

b. Hold the SHORT key (hold mode).



Note

The load cannot be shorted from the local load module in Parallel mode.

Display Output View

Background

The DISPLAY key can be used to switch the display output to different views.

Panel operation

1. Press the DISPLAY key repeatedly to switch between the different views.



V Voltage

A Current

W Power

S Load on time.



Note

The Display mode cannot be changed in Parallel mode.

Editing CC/CR/CV/CP A/B Value

Background The Slave Knob is used to edit the A Value or B Value (single channel load module) when in static mode. The Slave Knob can also operate in fine or coarse editing mode.

Panel Operation 1. Ensure the mode is in static mode. Page 125

2. Choose a channel (or choose A or B Value) by pressing the R/L or A/B key.



3. Press the Slave Knob to toggle between fine and coarse editing mode.

SEt_C = coarse mode.
SEt_F = fine mode.

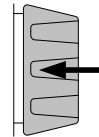

Fine mode example:

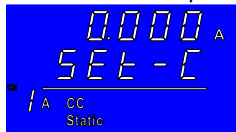

Coarse mode example:



4. Turn the Slave Knob to edit the A/B Value for the selected mode.

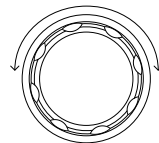

When the Slave Knob is set to "Measure", the slave knob must be pressed first to display the values on the load module display.

Editing the A/B Value is not possible with this method in Parallel mode.

Mainframe Basic Operation

For the Mainframe Basic Operation section, all operations refer to the knobs and keys on the main configuration panel, unless otherwise stated.

| | |
|--|------------|
| Mainframe Basic Operation | 130 |
| Help Menu..... | 131 |
| Channel Selection | 132 |
| Select CC Mode..... | 133 |
| Select CC Range..... | 134 |
| Select CC Dynamic Mode | 135 |
| Editing CC Dynamic Parameters..... | 135 |
| Select CC Static Mode..... | 137 |
| Editing CC Static Parameters | 138 |
| Set to CR Mode..... | 141 |
| Select CR Range | 141 |
| Select CR Dynamic Mode | 142 |
| Editing CR Dynamic Parameters..... | 143 |
| Select CR Static Mode..... | 145 |
| Editing CR Static Parameters | 145 |
| Select CV Mode..... | 148 |
| Editing CV Parameters | 149 |
| Select CV Response Speed | 151 |
| Select CP Mode..... | 152 |
| Editing CP Parameters | 153 |
| Select CP Range | 155 |

Help Menu

Background When any function key has been pressed or when a menu has been opened, the HELP key can be used to display a detailed description.

1. Press a function or system key on the front panel or open a menu.

Help Selection 2. Press the HELP key to display the built-in help.

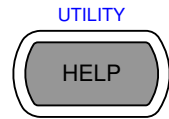

3. Use the scroll wheel to scroll down if necessary.

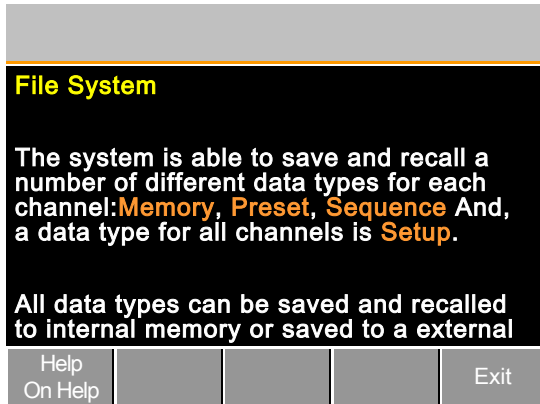
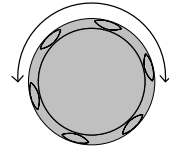

A detailed description of the function or menu item is shown.

4. Press F5 to exit.



Channel Selection

Background

There are up to 2 channels per load module, depending on the model. The main display can be used to control each channel individually.



When Parallel Unit configuration is enabled, channel selection is disabled. See page 195 for details.

Mainframe Channel selection

1. Press the CHAN button.

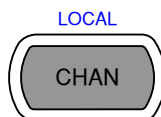

2. Select a channel by turning the Variable knob.

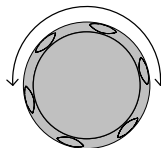

The channel selection appears highlighted in orange on the top right of the screen.

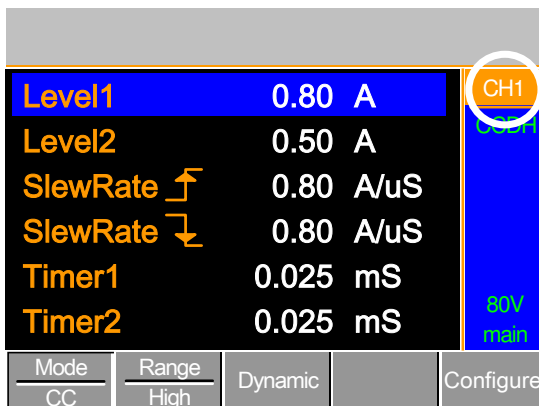

3. Press the Selector knob or Enter to confirm.



Select CC Mode

Background The PEL-2000A series load generators operate in four different modes: Constant Current (CC), Constant Resistance (CR), Constant Voltage (CV), and Constant Power (CP).

When a channel is active, the F1 key can be used to switch between each operating mode.

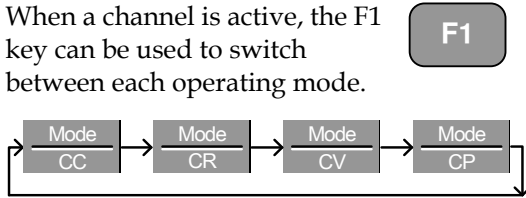

- Panel Operation**
1. Select a channel using the CHAN button and selector knob.
 2. Press F1 repeatedly until CC mode is displayed in the display panel.

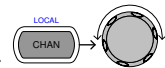

| | | | | |
|------|-------|---------|--|-----------|
| Mode | Range | Dynamic | | Configure |
| CC | High | | | |



Changing the operating mode will only affect the current (active) channel. Other channels will not be affected by any changes.

Select CC Range

Background Constant current mode can run in high and low range. Maximum range is dependent on the load module.

Ensure the menu is in CC Mode. See page 133.

| | | | | |
|------|-------|---------|--|-----------|
| Mode | Range | Dynamic | | Configure |
| CC | High | | | |

- Panel Operation**
1. Press the F2 (Range) key repeatedly until High or Low range is selected.

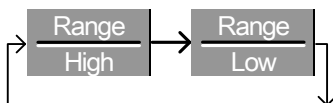

The range will be reflected in both the bottom menu system and the Current Operation Channel Status panel.

- | | |
|-----------------|------|
| CC Dynamic Low | CCDL |
| CC Dynamic High | CCDH |
| CC Static Low | CCL |
| CC Static High | CCH |



Note

Changing the range will only affect the current (active) channel. Other channels will not be affected by any changes.

Note, not all load modules support dual ranges. If only one range is supported, it is usually high range.

Select CC Dynamic Mode

Background Constant current mode can be set to dynamic or static mode. Dynamic mode is used to automatically set varying load rates.

Ensure the menu is in CC Mode. See page 133.

| | | | | |
|------|-------|---------|--|-----------|
| Mode | Range | Dynamic | | Configure |
| CC | High | | | |

Panel Operation 1. Press the F3 key until Dynamic Range mode is selected.

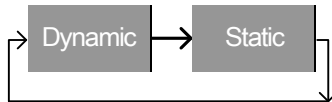
Note

Changing from static to dynamic mode will only affect the current (active) channel.

Editing CC Dynamic Parameters

Background Dynamic Constant Current Mode has two operating current levels, slew rates and timers.

Slew rates determine the speed at which the load will change from one level to the next.

The timers determine how long the load module/channel will stay at level 1 or level 2.

Ensure the menu is in CC Dynamic Mode. See page 135.

| | | | | |
|------|-------|---------|--|-----------|
| Mode | Range | Dynamic | | Configure |
| CC | High | | | |

| | | |
|------------|----------|-------------------------|
| Parameters | Level1 | 0~rating A |
| | Level2 | 0~rating A |
| | SlewRate | ↕ Load module dependent |
| | SlewRate | ↘ |
| | Timer1 | 0.025~30000.0 ms |
| | Timer2 | 0.025~30000.0 ms |



Note

When used in parallel mode, the Level1 & Level2 range is the combined rating of all the units used in parallel mode.

- Panel Operation 1. Use the Selector knob to highlight Level1.

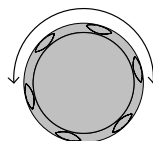

| | | | |
|-------------------|-------|------------------|---------------------------------|
| Level1 | | 0.80 A | CH1P CCDH 80V main |
| Level2 | | 0.50 A | |
| SlewRate ↕ | | 0.80 A/uS | |
| SlewRate ↘ | | 0.80 A/uS | |
| Timer1 | | 0.025 mS | |
| Timer2 | | 0.025 mS | |
| Mode | Range | Dynamic | Configure |
| CC | High | | |

2. Press the Selector knob to edit the selected level, then turn to increase or decrease the value*.

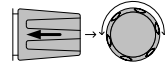

OR

Use the number pad to enter a number.

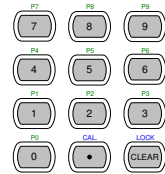

Level1 **0.80** **A**

3. Press the Selector knob or Enter to confirm selection.
4. Repeat steps 1-3 for the remaining parameters.



Note

Level1 & Level2 can be set for both High and Low Range.

*Press Shift to toggle between coarse and fine adjustment when editing the Level1 and Level2 parameters. See page 202 for details.

Select CC Static Mode

Background

Constant current mode can be set to dynamic or static mode. Static mode is for manually varying the load for single channel load modules or to set a static load on dual channel modules.

Ensure the menu is in CC Mode. See page 132.

| | | | | |
|------|-------|---------|--|-----------|
| Mode | Range | Dynamic | | Configure |
| CC | High | | | |

- Panel Operation 1. Press the F3 key until Static mode is selected.

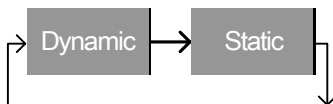

Note

Changing from static to dynamic mode will only affect the current (active) channel.

Editing CC Static Parameters

CC Values

When using a single channel load module, Static Constant Current Mode has two operating current values, A&B. If a dual channel load is used, only one current value is available per channel: A Value.

If Parallel Unit is enabled, an additional parameter, Switch Value, is available to switch from A Value to B Value.

Ensure the menu is in CC Static Mode. See page 137.

| | | | | |
|------|-------|--------|-----------|-----------|
| Mode | Range | Static | Seq. Edit | Configure |
| CC | High | | | |

Parameters

| | | |
|--------------|----------|--------------------------|
| A Value | 0~rating | A |
| B Value | 0~rating | A |
| SlewRate | ↕ | Load module dependent |
| SlewRate | ↘ | |
| Switch Value | | A/B (Parallel Unit only) |



Note

When Parallel Unit is enabled, the A Value & B Value range is the combined rating of all the units used in parallel mode, see page 75.

- Panel Operation 1. Use the Selector knob to highlight A Value.

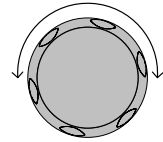

Single Channel Configuration

| LOAD | | USB | | |
|----------|-----------|--------|-----------|-----------|
| A Value | 0.80 A | CH1 | CCH | |
| B Value | 0.80 A | | | |
| SlewRate | 0.80 A/uS | | | |
| SlewRate | 0.80 A/uS | | | |
| Mode | Range | Static | Seq. Edit | Configure |
| CC | High | | | |

Parallel Unit Configuration

| LOAD | | USB | | |
|--------------|-----------|--------|-----------|-----------|
| A Value | 0.80 A | CH1P | CCH | |
| B Value | 0.80 A | | | |
| SlewRate | 0.80 A/uS | | | |
| SlewRate | 0.80 A/uS | | | |
| Switch Value | A | | | |
| Mode | Range | Static | Seq. Edit | Configure |
| CC | High | | | |

2. Press the Selector knob to edit the selected value, then turn to increase or decrease the value*.

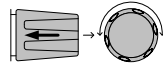

OR

Use the number pad to enter a number.

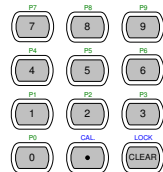

A Value **0.80** **A**

3. Press the selector knob or Enter to confirm selection.
4. Repeat steps 1-3 for the remaining parameters.





Note

The last Value (A Value or B Value) that is set becomes the active setting. To swap between A Value and B Value, use the A/B keys on the local load module. This is not applicable to Parallel Unit mode.

For Parallel Unit mode, use the Switch Value parameter to switch between A and B Value.

A & B Value have the same Range: High or Low.

*Press Shift to toggle between coarse and fine adjustment when editing the A Value and B Value parameters. See page 202 for details.

Set to CR Mode

Background The PEL-2000A series load operates in four different modes, Constant Current (CC), Constant Voltage (CV), Constant Resistance (CR) and Constant Power (CP). Constant Resistance mode will maintain a constant resistive load, using variable current and voltage levels.

When a channel is active, the F1 key can be used to switch between each operating mode.

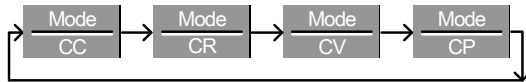

Panel Operation 1. Press the CHAN button and use the selector knob to select a channel.

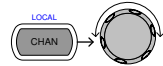

2. Press F1 until CR mode is displayed in the display panel.



| | | | | |
|------|-------|---------|--|-----------|
| Mode | Range | Dynamic | | Configure |
| CR | Low | | | |



Note

Changing the operating mode will only affect the current (active) channel. Other channels will not be affected by any changes.

Select CR Range

Background Constant Resistance mode can run in high and low range. Range is dependent on the load module.

Ensure the menu is in CR Mode. See page 141.

| | | | | |
|------|-------|---------|--|-----------|
| Mode | Range | Dynamic | | Configure |
| CR | Low | | | |

- Panel Operation 1. Press the F2 (Range) key repeatedly until High or Low range is selected.

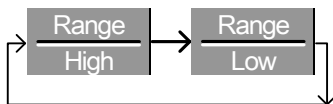

The range will be reflected in both the bottom menu system and the Current Operation Channel Status panel.

- CR Static Low CRL
- CR Static High CRH
- CR Dynamic Low CRDL
- CR Dynamic High CRDH



Note

Changing the range will only affect the current (active) channel. Other channels will not be affected by any changes.

All resistance values and slew rates are dependent on Range, i.e., A Value in low range can be different from A Value in high range.

Select CR Dynamic Mode

Background Constant Resistance mode can be set to dynamic or static mode. Dynamic mode is used to automatically set varying load rates.

Ensure the menu is in CR Mode. See page 141.

| | | | | |
|------|-------|---------|--|-----------|
| Mode | Range | Dynamic | | Configure |
| CR | Low | | | |

- Panel Operation 1. Press F3 until Dynamic Range mode is selected.

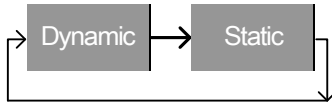

Note

Changing from static to dynamic mode will only affect the current (active) channel.

Editing CR Dynamic Parameters

CR levels Dynamic Constant Resistance Mode has two operating resistance levels, slew rates and timers.

Slew rates determine the speed at which the load will change from one level to the next.

The timers determine how long the load module/channel will stay at level 1 or level 2. See the CR operating description for details about slew rates and timers, page 67

Ensure the menu is in CR Dynamic Mode. See page 142.

| | | | | |
|------|-------|---------|--|-----------|
| Mode | Range | Dynamic | | Configure |
| CR | Low | | | |

| | | |
|------------|----------|---------------------------|
| Parameters | Level1 | Minimum ~ rating Ω |
| | Level2 | Minimum ~ rating Ω |
| | SlewRate | ↗ Load module dependent |
| | SlewRate | ↘ |
| | Timer1 | 0.025~30000.0ms |
| | Timer2 | 0.025~30000.0ms |



Note

When used in parallel mode, the Level1 & Level2 range is the combined rating of all the units used in parallel mode.

- Panel Operation
1. Use the Selector knob to highlight Level1.

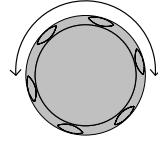

| | | | | |
|-----------------|--------------|---------|------------------|-------------|
| Level1 | | | 100.000 Ω | CH1 CRDL |
| Level2 | | | 100.000 Ω | |
| SlewRate | | | 0.40 A/uS | 80V main |
| SlewRate | | | 0.40 A/uS | |
| Timer1 | | | 0.025 mS | |
| Timer2 | | | 0.025 mS | |
| Mode CR | Range Low | Dynamic | | Configure |

2. Press the Selector knob to edit the selected level, then turn to increase or decrease the value*.

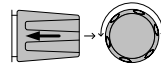

OR

Use the number pad to enter a number.

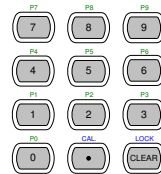

Level1 100.000 Ω

3. Press the Selector knob or Enter to confirm selection.

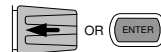

4. Repeat steps 1-3 for the remaining parameters.



Note

Level1 & Level2 can be set for both High and Low Range.

*Press Shift to toggle between coarse and fine adjustment when editing the Level1 and Level2 parameters. See page 202 for details.

Select CR Static Mode

Background

Constant Resistance mode can be set to dynamic or static mode. Static mode is for manually varying the load for single channel load modules or to set a static load on dual channel modules.

Ensure the menu is in CR Mode. See page 141.



Panel Operation

1. Press the F3 key until Static mode is selected.

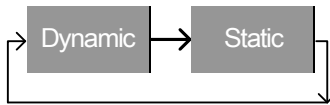

Note

Changing from static to dynamic mode will only affect the current (active) channel.

Editing CR Static Parameters

Background

Single channel load modules have two resistance levels, A Value & B Value. Dual channel load modules have only one resistance level per channel, A Value.

When Parallel Unit is enabled, an additional parameter, Switch Value, is available to switch from A Value to B Value.

Ensure the menu is in CR Static Mode. See page 145.

| | | | | |
|------------|--------------|--------|--------------|-----------|
| Mode CR | Range Low | Static | Seq. Edit | Configure |
|------------|--------------|--------|--------------|-----------|

| | | | |
|------------|--------------|--------------------------|----------|
| Parameters | A Value | 0~rating | Ω |
| | B Value | 0~rating | Ω |
| | SlewRate | ↕ Load module dependent | |
| | SlewRate | ↘ | |
| | Switch Value | A/B (Parallel Unit only) | |



Note

When Parallel Unit is enabled, the A Value & B Value range is the combined rating of all the units used in parallel mode.

- Panel Operation
- Use the Selector knob to highlight A Value.

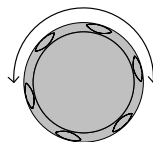

Single Channel Configuration

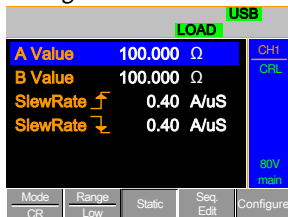

Parallel Unit Configuration

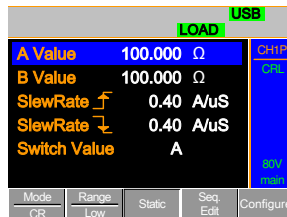

- Press the Selector knob to edit A Value / B Value, then turn to increase or decrease the value*.

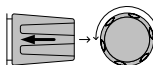

OR

Use the number pad to enter a number.

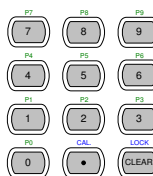

A Value

100.000

 Ω

3. Press the selector knob or Enter to confirm selection.
4. Repeat steps 1-3 for B Value (if applicable), rising and falling SlewRate.



Note

The last Value (A Value or B Value) that is set becomes the active setting. To swap between A Value and B Value, use the A/B keys on the local load module (not applicable to Parallel Unit mode).

For Parallel Unit mode, use the Switch Value parameter to switch between A and B Value.

A/B Value and rising/falling SlewRate can be set for both High and Low Range.

*Press Shift to toggle between coarse and fine adjustment when editing the A Value and B Value parameters. See page 202 for details.

Select CV Mode

Background The PEL-2000A series electronic load operates in four different modes, Constant Current (CC), Constant Resistance (CR), Constant Voltage (CV), and Constant Power (CP).

CV Mode cannot be used with the Parallel Unit mode.

When a channel is active, the F1 key can be used to switch between each operating mode.

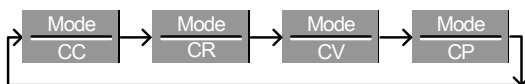

Panel Operation 1. Press the CHAN button and use the selector knob to select a channel.

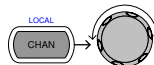

2. Press F1 until CV mode is displayed in the display panel.

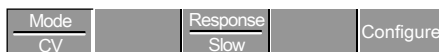

Changing the operating mode will only affect the current (active) channel. Other channels will not be affected by any changes.

CV mode only operates in High range.

Editing CV Parameters

Background Constant Voltage mode can be set to a maximum limit (Curr Limit). Using the current limit enables limiting the current draw.

When using CV mode on single channel load modules, two voltage levels can be sunk, A Value and B Value. On a dual channel load module, only one voltage level can be sunk per channel: A Value.

Ensure the menu is in CV Mode. See page 148.

| | | | | |
|------|--|----------|--|-----------|
| Mode | | Response | | Configure |
| CV | | Slow | | |

| | | | |
|------------|------------|-----------------------|---|
| Parameters | A Value | 0~rating | V |
| | B Value | 0~rating | V |
| | Curr Limit | Load module dependent | |

- Panel Operation** 1. Use the Selector knob to highlight A Value.

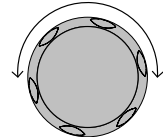



- Press the Selector knob to edit the selected value, then turn to increase or decrease the value*.

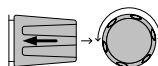

OR

Use the number pad to enter a number.



A Value 10.00 **V**

- Press the selector knob or Enter to confirm selection.
- Repeat steps 1-3 for the remaining parameters.

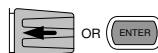

Note

The last Value (A Value or B Value) that is set becomes the active setting. To swap between A Value and B Value, use the A/B keys on the local load module.

When setting the current limit, please ensure that the current limit is within the test device's limits.

*Press Shift to toggle between coarse and fine adjustment when editing the A Value and B Value parameters. See page 202 for details.

Select CV Response Speed

Background Constant voltage mode has fast and slow response speeds. Quick current changes can induce line voltage, making it more difficult for the PEL load generator to maintain a constant current. In these types of conditions, slow response speed is recommended. Maximum current range is dependent on the load module type.

Ensure the menu is in CV Mode. See page 148.



- Panel Operation**
1. Press F3 (Response) to switch between Fast and Slow response speeds.

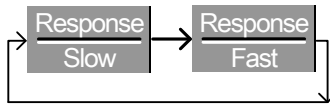

Response speed settings will be reflected in the Current Operation Channel Status panel.

CV Slow Response Slow
 CV Fast Response Fast



Note

Changing the response speed will only affect the current (active) channel. Other channels will not be affected by any changes.

Select CP Mode

Background The PEL-2000A series electronic load operates in four different modes, Constant Current (CC), Constant Resistance (CR), Constant Voltage (CV), and Constant Power (CP).

CP mode cannot be used with the dedicated Parallel Unit mode.

When a channel is active, the F1 key can be used to switch between each operating mode.

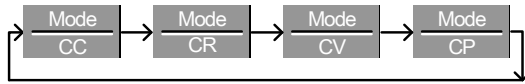

Panel Operation 1. Press the CHAN button and use the selector knob to select a channel.

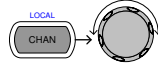

2. Press F1 until CP mode is displayed in the display panel.



Changing the operating mode will only affect the current (active) channel. Other channels will not be affected by any changes.

Editing CP Parameters

Background Constant Power mode can be set to have a maximum limit (Curr Limit). Using the current limit enables limiting the current draw.

When using CP mode on a single channel load module, two power levels can be configured, A Value and B Value. On a dual channel load module, only one power level can be configured per channel: A Value.

Ensure the menu is in CP Mode. See page 148.

| | | | | |
|------|-------|--|--|-----------|
| Mode | Range | | | Configure |
| CP | Low | | | |

| | | | |
|------------|------------|-----------------------|---|
| Parameters | A Value | 0~rating | W |
| | B Value | 0~rating | W |
| | Curr Limit | Load module dependent | |

- Panel Operation** 1. Use the Selector knob to highlight A Value.

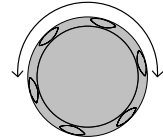



- Press the Selector knob to edit the selected value, then turn to increase or decrease the value.

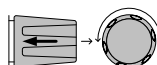

OR

Use the number pad to enter a number.



A Value 10.00 **W**

- Press the selector knob or Enter to confirm selection.
- Repeat steps 1-3 for the remaining parameters.

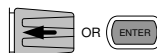

Note

The last Value (A Value or B Value) that is set becomes the active setting. To swap between A Value and B Value, use the A/B keys on the local load module.

When setting the current limit, please ensure that the current limit is within the test device's limits.

Select CP Range

Background Constant Power mode can run in high and low range. Range is dependent on the load module.

Ensure the menu is in CP Mode. See page 148.

| | | | | |
|------|-------|--|--|-----------|
| Mode | Range | | | Configure |
| CP | Low | | | |

Panel Operation 2. Press the F2 (Range) key repeatedly until High or Low range is selected.

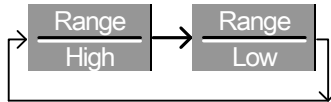

The range will be reflected in both the bottom menu system and the Current Operation Channel Status panel.



| | |
|---------------|-----|
| CP High Range | CPH |
| CV Low Range | CPL |



Changing the range will only affect the current (active) channel. Other channels will not be affected by any changes.

Creating a Program Sequence

Background

The PEL-2000A series has a total of 12 different programs and 10 sequences to each program. That totals to 120 different configurations.

Each Sequence in each program uses the settings saved from Memory Data (Memory MXXX). Memory Data contains settings such as the mode and range for each channel. Different Sequences can use the same Memory Data repeatedly. Each Sequence loads all channels at the same time, unless programmed otherwise.

| Sequence1 | |
|-----------|------------|
| CH1 M001 | Run |
| CH2 M001 | On-Time |
| CH3 M001 | Off-Time |
| CH4 M001 | Short-Time |
| CH5 M001 | P/F-Time |
| CH6 M001 | Short CH1 |
| CH7 M001 | ~ |
| CH8 M001 | Short CH8 |

Sequences are run sequentially to create a Program. There are 10 Sequences in each Program.

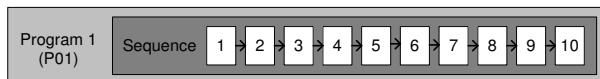

If less than 10 Sequences are desired for a Program, any additional Sequences can be skipped (not run).

Sequence 2 & 3 are skipped.

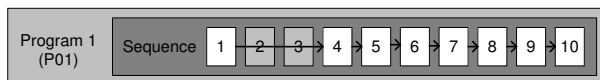

| | | |
|------------|------------|------------------------------------|
| Parameters | Memory | M001~M120 |
| | Run | Skip-Auto-Manual |
| | On-Time | 0.1 ~ 60.0 S |
| | Off-Time | Off - 0.1 ~ 60.0 seconds |
| | P/F Time | Off - 0.1 ~ (On-Time+Off-Time)-0.1 |
| | Short-Time | Off - 0.1 ~ On-Time |



Note

Before a program can be created, the settings for each sequence for every channel that is to be used in the program must first be pre-configured and saved into Channel Memory (MXXX). See the Save/Recall chapter for further details, page 236.

Sequence Settings

1. Press the FUNC key then F1 (Program) to access the Program menu.

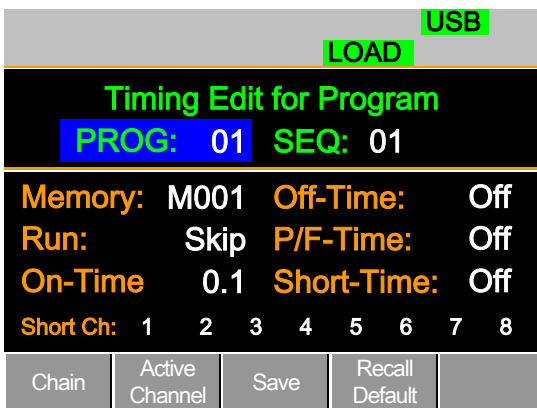

2. Use the Selector Knob to highlight PROG:.

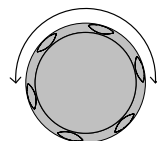

- Press the selector knob to edit PROG:, then turn to select the program number.

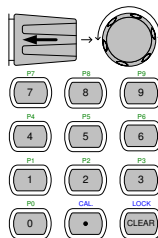

OR

Use the number pad to enter a program number.

Program: 01 ~12

- Press Enter or push the selector knob to confirm.

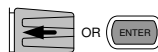

- Repeat steps 2-4 to choose the sequence number (SEQ:).

Sequence: 01 ~ 10

As sequences are executed sequentially, start at SEQ: 01.

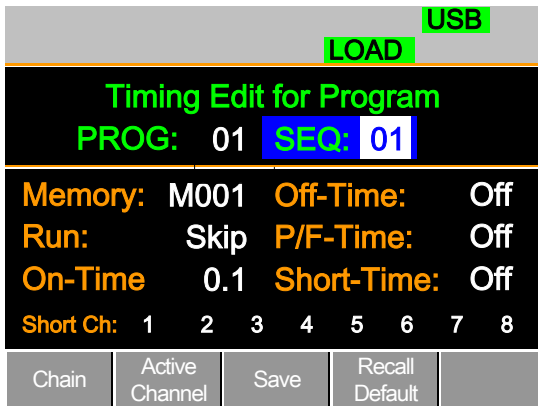

- Repeat steps 2-4 to configure the following for the current Program Sequence:

Memory: M001 ~M120

Choose which Memory data will be used for the sequence. CH1 MXXX ~ CH8 MXXX.

Run: Skip – Auto - Manual

Choose whether to run the sequence in the program automatically, skip the sequence or manually start the sequence.

On-Time: 0.1 ~ 60.0 seconds

Determines how long the sequence will run for (seconds).

Off-Time: Off – 0.1 ~ 60.0 seconds

Sets how long the sequence will stay off for (in seconds) between each sequence. Assuming Short time is not set to OFF, Off-Time will always run after On-Time.

Short Time: Off – 0.1 ~ On-Time (seconds)

Determines how long a short circuit will last (seconds). However the shorting time cannot be longer than the On-time. Short Time will start at the same time as On-time.

P/F Time: Off – 0.1 ~ (On-Time+Off-Time)-0.1 (seconds)

The Pass(P)/Fail(F) Time can be set to 0.1 seconds less than the total test time. The total test time is defined as:

$$\text{On-Time} + \text{Off-Time (seconds)}$$

If Go/NoGo is turned on but the pass fail time is off, then Go/NoGo test will continue, but there will not be a specified pass/fail time window.

Short Channel: Off – 1~ 8 (CH1~CH8)

Each channel can be individually set to simulate a short circuit (CH1~8) or can have shorting disabled (Off). When Short Channel is set to Off, the channel is enabled.

7. Repeat the above steps for all ten sequences for the same (current) program.

Save Sequence

8. Press F3 (Save) to save all the sequence data for the current program.



Note

Note the program data is not yet saved into Setup Memory. If you wish to save the Program to Setup Memory see page 239.

Recall Default

9. To recall the Default Program settings, press F4.



Note

If the Default is recalled, all data will be lost. This does not include the internal Setup Memory. To see the default settings, see page 285.

Program Chains

Background On the PEL-2000A, there are up to 12 different programs containing 10 sequences.

If 10 sequences in a Program Sequence prove to be inadequate for testing, the PEL2000A series can chain different programs together, effectively making a larger Program Sequence.

Unlike Program Sequences, Program Chains do not need to be run in numerical order. Up to 12 Program Sequences can be chained together

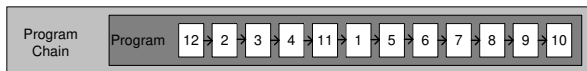

- Panel operation**
1. Create 1 or more Program Sequences. Page 152
 2. If Program Sequences were created in a different session, ensure the programs have been loaded from Setup Memory. Page 239
 3. Press the FUNC key, then Program (F1), followed by Chain (F1).

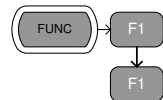

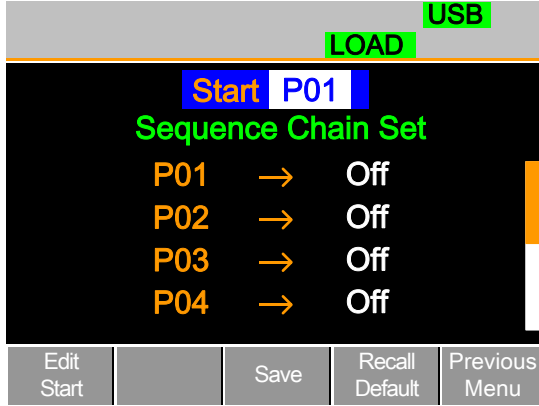

4. Use the selector knob to edit Start and confirm which Program Sequence (PXX) will start the program chain. Any Program (P01~P12) can be used to start a Program Chain.

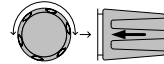

5. Use the Selector knob to scroll down to P01 (Program 1).

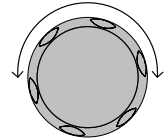

6. Use the Selector knob to choose the program that will execute after P01 (P02~P12).

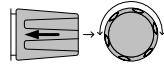

OR

Select (Off) to end the Program Chain after (P01).

OR

Select (P01) to execute after P01, this will create a continuously looping Program Chain.

P01 → Off – P01~P12

- Repeat the above procedure to P02~P12 to complete the program chain.

The Program Chain ends at the first Program (PXX) that is followed by Off. It is possible to create continuously looping program chains.

Save Program Chain

- Press F3(Save) to save the program chain.



Note

Note the Program Chain data is not yet saved into Setup Memory. If you wish to save the Program Chain to Setup Memory see page 239.

Recall Default

- To recall the Default program chain, press F4.



Note

If the Default is recalled, Start will revert to P01 and all program sequences will be set to Off.

Previous Menu

- Press F5 (Previous Menu) to return the Sequence menu.



Running a Program

Background

Once a Program Chain/Program Sequence has been created, it can be executed. As Program Sequences apply to all the channels, any channels that don't need to be active (load off) can be programmed in the Active Channel menu. At Default, all channels are set to (load) Off.

EXT will be shown next to any channels set to external channel control.

Panel operation

- Create 1 or more Program Sequences. Page 152.
- Create a Program Chain. Page 161.

3. Press the FUNC key, Program (F1) and Active Channel (F2).

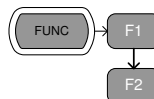

Channel 1 (CH01) will be highlighted. Note CH1 has CH CONT set to External

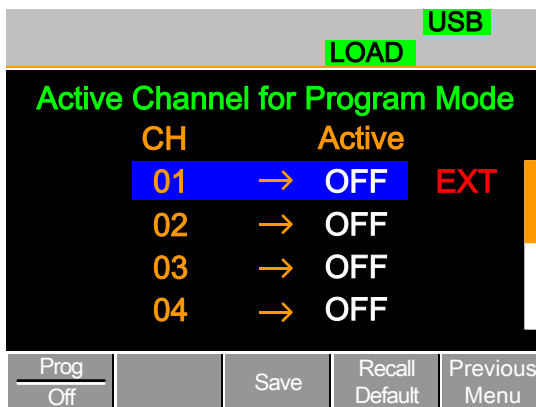

4. Edit the channel using the Selector knob.

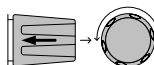

CH 01~08: ON (activate channel) – OFF (not activated)

5. Press Enter or push the selector knob to confirm the selection.

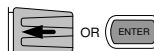

6. If needed, repeat steps 4-5 for the remainder of the channels.



Note

If all channels are Active OFF, a program cannot be run as there will be no channels active.

Save Program

7. To save press F3.



Recall Default

8. To recall default settings press F4



Note

If the Default is recalled, all channels will revert to Active OFF.

Previous Menu 9. Press F5 (Previous Menu) to return to the Sequence menu. 

Turn Program On/Off 10. Press F1 (Prog) to turn On or Off the current Program. 

Pressing F1 will cycle from Program On to Off.

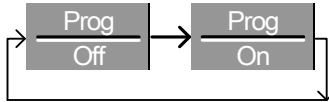

11. PROG will appear on the mainframe status panel when the program is turned on.



Run Program 12. Press the load key on the mainframe to start the Program. 

13. The Run Program screen appears, and the PROG icon turns orange.

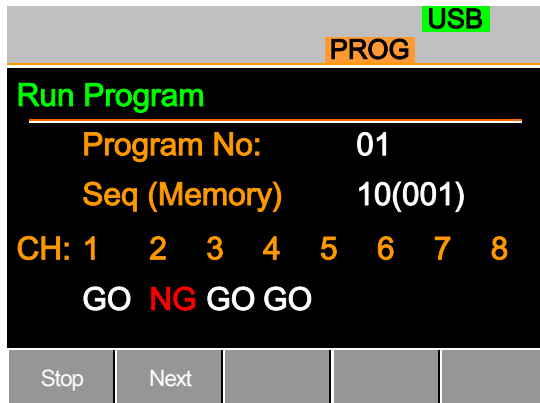

As each sequence or program is completed the screen will update to display the active sequence/program. Notice that if a channel has been set up with Go/NoGo limits, a pass (GO) or fail (NG) will be displayed on the main display as well as the local load module display.

The program icon will become orange when a program has started.



Note

If the Active=OFF for all the channels then “No Active Channel” will be displayed instead of channel numbers.

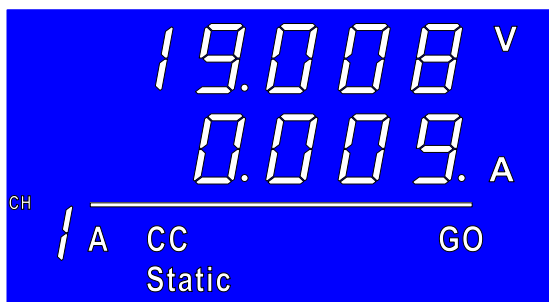

Each active load module will display the output as the program runs.

14. If Run was configured to manual in any of the program sequences, press F2 (Next) to continue the program sequence, otherwise the program will continue automatically.

F2

15. Press F1 (Stop) at any time to abort the program when it is running.

F1

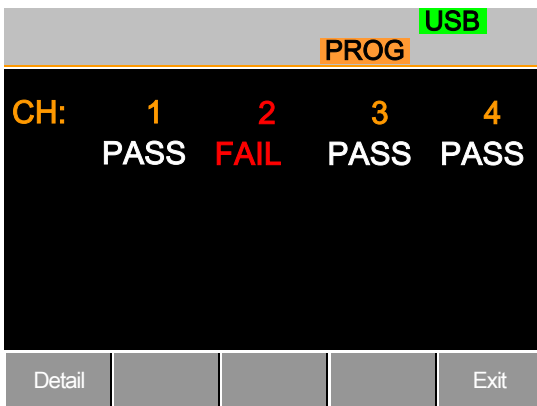

When the program has finished, the physical channels that have run will be displayed, a PASS or FAIL will be displayed if Go/NoGo testing has been set.

- 16. When the program has finished, press F1 to see any result details. F1

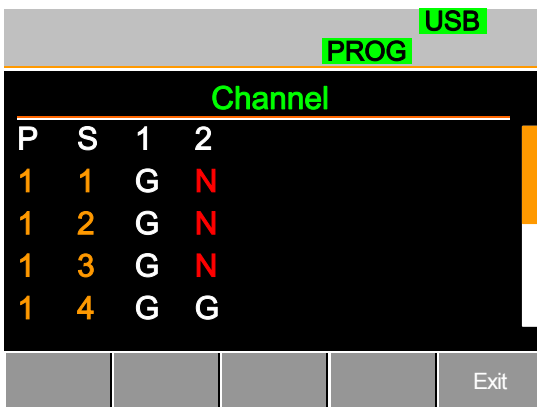

The Program (P) and Sequence (S) numbers for the Program are displayed on the left hand side and the Go/NoGo (G/N) results are displayed on the right hand side for each channel in the program.

Use the Selector knob to scroll down to view the remainder of the list if necessary.

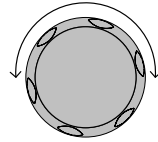

17. Press F5 to exit at any time.



Upon exiting, the previous menu before running the program will load.

Edit Sequence



Background The Sequence function can be configured to create a unique load profile to accurately simulate loads in real time for single or multiple loads. Sequence can only be used with CC static or CR static modes. For details see page 80.

Each Sequence is composed of a number of points with customizable current/resistance, slew rate and duration times. Each sequence can be looped an infinite amount of times. Sequences are only applicable for CC (Static) and CR (Static) modes.



Note

The sequence function should not be confused with program sequences. They are not the same. Program sequences cannot be used with the Sequence function and vice versa.

| Parameters | Value | 0~rating*1.02 Ω/ A |
|--|-------------------------|-----------------------|
| SlewRate  | | Load module dependent |
| SlewRate  | | |
| Duration Time | 0.000025~60,000 seconds | |

- Panel operation**
1. Choose a channel and mode. Page 130, 133
 2. Press the CHAN key, F4 (Seq. Edit) to enter the Sequence Edit menu.



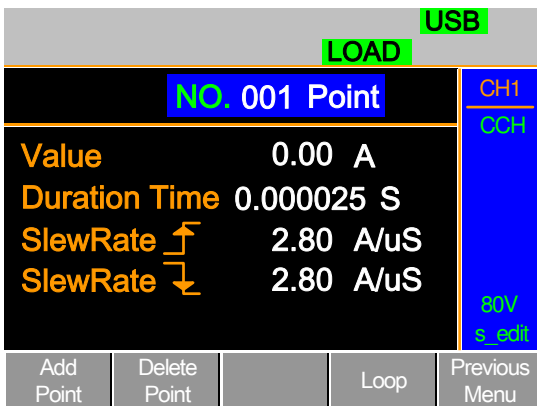

- Use the Selector knob to highlight Value.

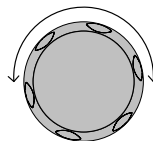

- Press the Selector knob to edit the Value, then turn to increase or decrease the value.

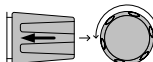

OR

- Use the number pad to enter a number.



Value 0.800 A

- Press the Selector knob or Enter to confirm selection.

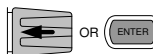

- Repeat for rising and falling Slew Rate and Duration Time.

Add Point 8. To add an extra point after the current point, press Add Point (F1). 

Range 001~120



Note

Add Point will insert a new point directly after the current point. The value of the current/resistance of the inserted point will be the average of the point before and after. All other settings will remain unchanged.

Delete Point 9. To delete the current point, press Delete Point (F2). 

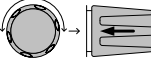
Edit previous point 10. Use the selector knob to change the current point number. 

001 Point



Note

The Point number can only be changed if more points have already been added.

Save Sequence 11. Press Save (F3) to save the sequence. 



Note

The save icon will only appear after a change has been made in the menu.

Create Sequence Loop

Background Sequences can be looped a number of times. The loops can be started at any point in the sequence. The Start of Loop function determines which point will start each repeating loop.

The On End of Seq. function will hold the load current (of the selected sequence) to a designated value until all the other sequences have finished running.

CC Vrange sets the range in CC mode for Sequences.

See page 80 for more details.

Ensure the menu is in the Seq. Edit menu and that a sequence has been created. See page 169

| | | | | |
|-----------|--------------|--|------|---------------|
| Add Point | Delete Point | | Loop | Previous Menu |
|-----------|--------------|--|------|---------------|

| | | |
|-------------------|----------------|----------------------------------|
| Parameters | Repeat | 1~9999/Infinity (0) |
| | Start of Loop | 001~ last point |
| | On End of Seq. | OFF / 0.1A ~ rating current*1.02 |
| | CC Vrange | High/Low |

- Panel operation**
1. Press Loop (F4) to enter the Loop menu.



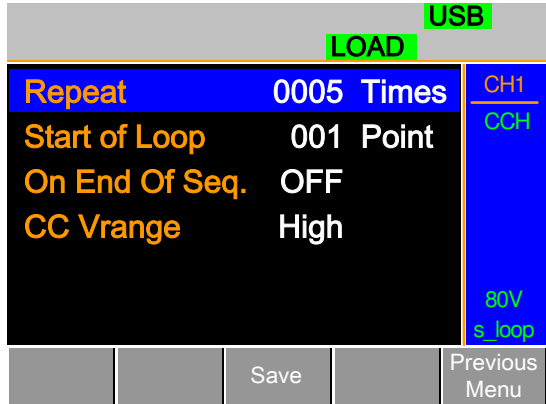

2. Use the Selector knob to highlight Repeat.

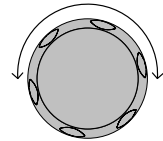

3. Press the Selector knob to edit Repeat, then turn to increase or decrease the value.

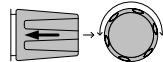

OR

4. Use the number pad to enter a number.

Select 0 to choose infinity.

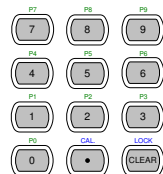

Repeat 0005 Times

5. Press the Selector knob or Enter to confirm selection.
6. Repeat for the remaining parameters.

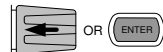

Save Loop

7. Press Save (F3) to save the loop.



Channel Duration Time Settings

Background Each sequence can have the timing duration data of another sequence. For example CH1's sequence can import the timing duration settings of CH2's sequence.

This is useful to quickly compare two different loads to the same timing characteristics. See page 80 for more details.

Each channel's sequence can be turned off by configuring the channel Setting to OFF. If a channel uses the same channel number, i.e. CH 01 → 01, then the duration time settings will not be altered for that channel.

One channel must output a Trigger Sequence Signal via PIN4 of the first frame link connector (master) if a sequence is run. For more details see page 80.

The Trigger In signal is used to start any sequence that has TRIG set to IN. The trigger input signal is input via PIN4 of the second frame link connector (slave).

For more details, see page 80.

Any channels with channel control (CH CONT) set to external will be shown on the right side as EXT. See page 197 for details on setting channel control.

| | | |
|-----------|----------|------------------------|
| Parameter | CH 01~08 | OFF ~ maximum channels |
| | TRIG | OUT |
| | TRIG | IN |

Ensure at least one sequence has been created and saved. Page 169

- Panel operation 1. Press FUNC, then Sequence (F2) to enter the Channel Duration Time menu.

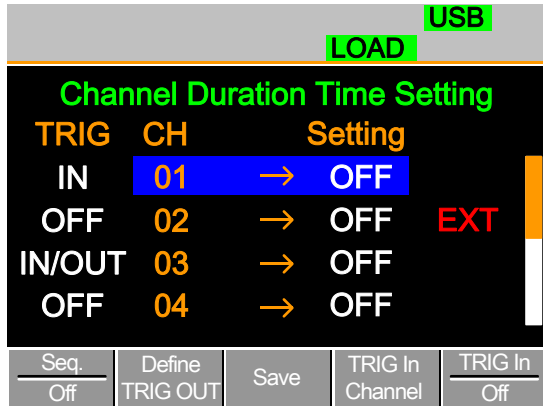
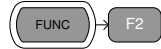

Note CH3 is set to TRIG OUT, whilst CH1 & CH3 are set to TRIG IN. CH2 has no trigger settings and has CH CONT set to external.

2. Use the Selector knob to highlight a channel.

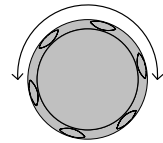

3. Press the Selector knob to edit the channel, and then turn to choose which channel's Duration Time Setting to import.

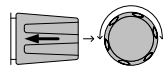

Range Ch 01~08 / OFF



4. Press the Selector knob or Enter to confirm selection.



Trigger Out
Channel

5. Press Define TRIG OUT (F2) if you want the currently selected channel to output the Trigger sequence signal.

A grey rounded rectangular button with the text "F2" in white.

One channel must be set as the TRIG OUT channel.

Trigger In
Channel

6. Press TRIG In Channel (F4) to allow the current sequence to be triggered with the Input trigger.

A grey rounded rectangular button with the text "F4" in white.

7. To turn the Input trigger source on, press Trig In (F5).

A grey rounded rectangular button with the text "F5" in white.

8. Repeat the above steps for any other remaining channels.

9. Press Save (F3) to save the settings.

A grey rounded rectangular button with the text "F3" in white.

Run Sequence

Background

Like Programs, Sequences must be turned "ON" before they can be run.

When running a Sequence, the front panel function keys, number pad, operation keys and selector knob are disabled for the specific channel(s). The load module panel is also disabled (bar the display key) for the specific channel.

Channels that do not have a Sequence can still be edited by changing channels via the CHAN key or by using the local load module.

Ensure at least one Sequence has been created and saved. Page 169

Ensure the Channel Duration Time Settings have also been configured and that no Sequence (CH01~08) that you wish to run are set to OFF.

Panel operation

1. Press FUNC, then Sequence (F2) to enter the Channel Duration Time Setting menu.

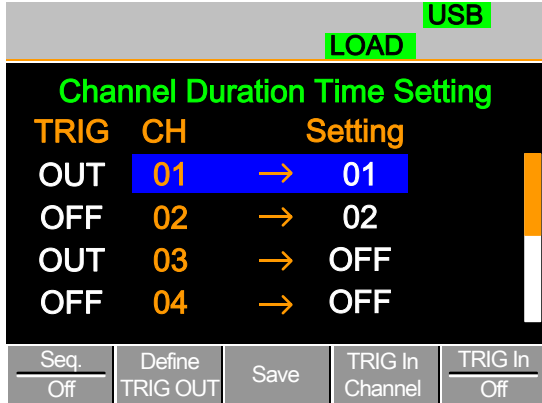

2. Press Seq. (F1) to turn on the Sequences.
3. SEQ will be displayed on the Mainframe Status panel.



4. Press the LOAD key to run all the Sequences. If a channel has TRIG set to IN, that channel will now wait for a trigger before running.
5. Run SEQ Mode will be displayed on the bottom of the display for the specific channels. On the Mainframe Status panel, SEQ will turn orange.

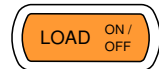

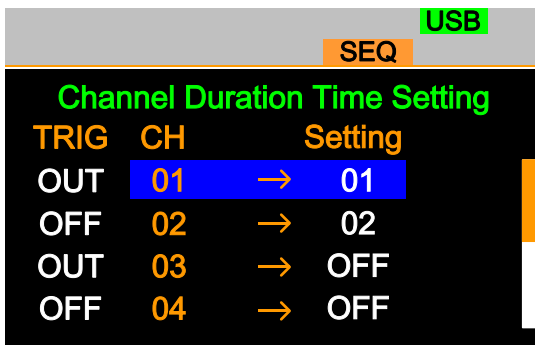

Run SEQ Mode

Stop the load

6. Press the LOAD key again or wait for the Sequence (if not infinitely looped) to end/stop the load.

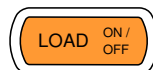

Turn off SEQ

7. Press Seq. (F1) to turn OFF the Sequence(s) when the load is not running.



Note

All UI keys/dials will be disabled for all channels that run a Sequence, bar the function keys and R/L keys.

OCP Test Automation

Background

The OCP test function creates an automatic test to test the OCP of power supply products.

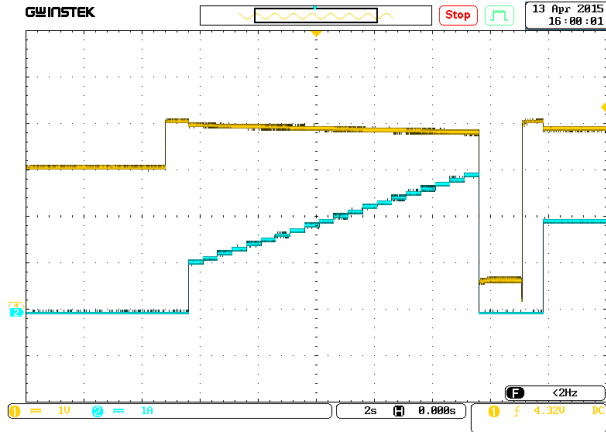

Parameters

| | |
|------------------------|--|
| Active Channel | Applies the setting to the load channel. |
| Range | High(CC Mode High) or Low(CC Mode Low) |
| Start Current(Start C) | Starting current value for the test. |
| End Current(End C) | The current value that will end the test. The value must be higher than the OCP value of the DUT you are testing. This parameter is used as a fail-safe for if the over current protection of the DUT fails. |
| Step Current(Step_C) | Sets the step resolution of the current. |

| | |
|----------------------|--|
| Last Current(Last_C) | Sets the final current value after OCP has been tripped. This is the steady-state current draw after the OCP has been tripped. |
| Step Time(Step_T) | Sets the execution time of each step. (50mS to 1600S) |
| Delay Time(Delay) | The OCP testing delay time. Sets the how long to delay starting the test after the Load On key has been pressed. (5mS ~ 160mS) |
| Trig Voltage(Trig_V) | Sets the voltage trigger level needed see whether the power supply OCP has been triggered. When the power supply OCP has been triggered, its voltage output will reset. The voltage trigger level is used to test to see if the voltage output has been reset. |



Note

This mode can only be used under CC mode.

Panel operation

1. Press the FUNC key, F4 (OCP) to enter the OCP Test Automation menu.



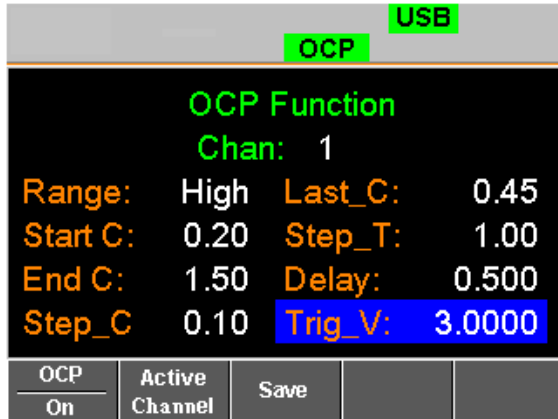

2. Use the Selector knob to highlight the parameter you want to edit.

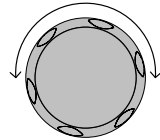

3. Press the Selector knob to edit the parameter, then turn to increase or decrease the value.

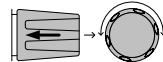

OR

Use the number pad to enter a number.

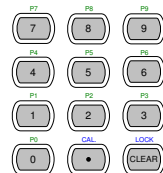

4. Press the Selector knob or Enter to confirm selection.
5. Repeat steps 2 -4 for all the parameters.

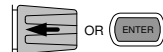

Save the OCP Test Automation Settings

6. Press F3 (Save) to save the OPC Test Automation settings.



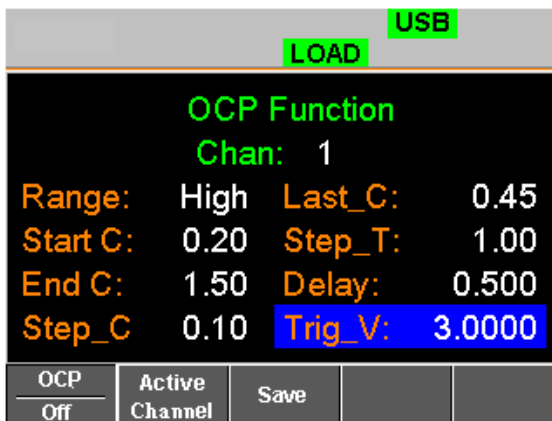

Select Active Channel

- To select the load channels for the test, press Active Channel (F2).

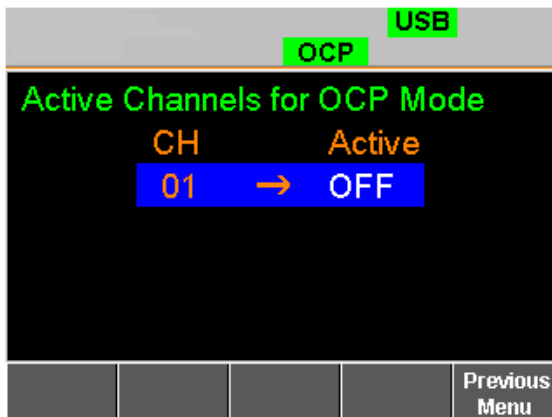

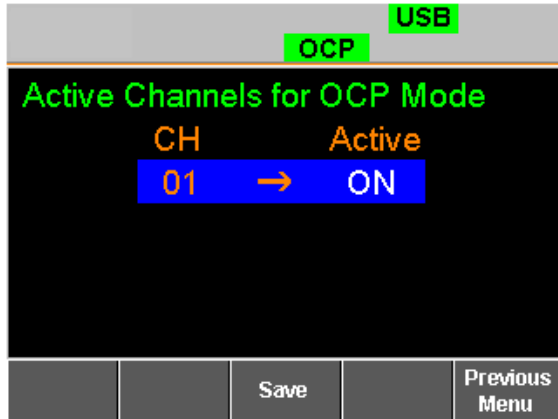

- 8. Use the selector knob to Enter key to turn the Active value to ON.



Save the OCP Test Automation Channel

- 9. Press Save (F3) to save the OCP test automation channel.



- 10. Press Previous Menu (F5) to return to the OCP Test Automation menu.



- 11. Press OCP (F1) to turn OCP to ON.

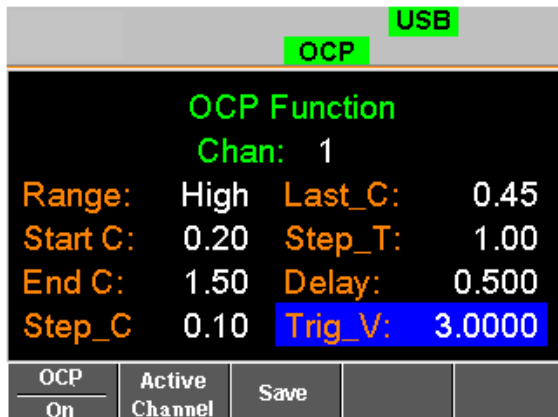

Save the OCP Test Automation Parameters 12. Press Save (F3) to save the OCP test automation parameters.



Start the OCP Test Automation 13. Press the Load key to start to OCP Test Automation.

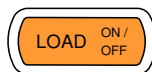

Results 14. Test Results

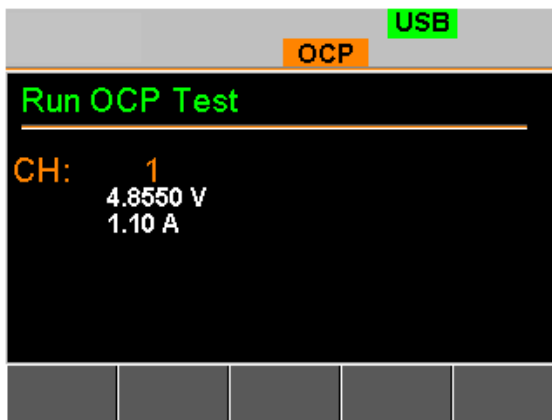

Voltage Reading: The voltage of the DUT before the OCP was triggered.

Current Reading: The current of the DUT before the OCP was triggered.



In addition to the setting the OCP test parameters as described above, the VON voltage settings must also be set according to the output characteristics of the DUT.

An OCP Test Automation example using actual current and voltage waveforms.

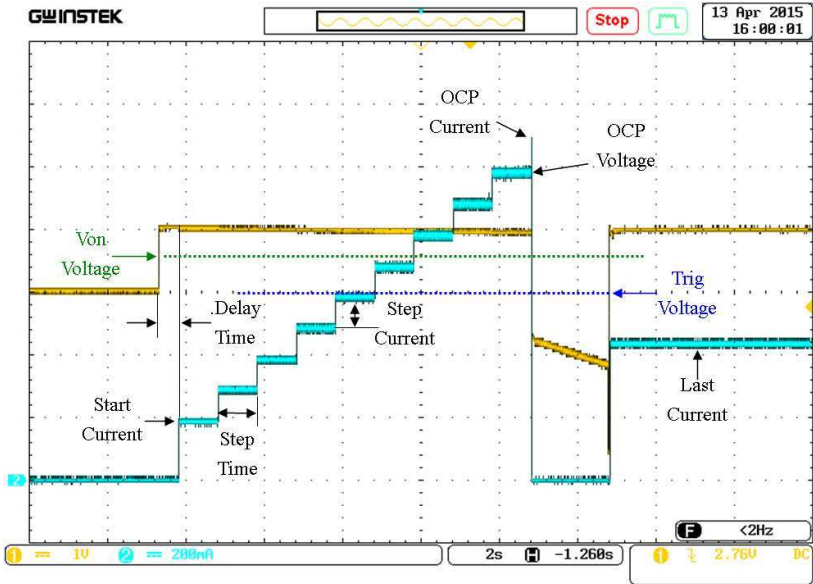

Channel Configuration

The Channel Configuration chapter describes the configuration options for individual channels. Any configuration settings that are changed only apply to the current channel, other channels will not be changed.

| | |
|---------------------------------------|------------|
| Channel Configuration | 186 |
| Accessing the Configuration Menu..... | 187 |
| Setting (OCP/OVP/OPP/UV) | 188 |
| Protection Clear | 191 |
| Setting the CC Voltage Range | 192 |
| Adjusting the Von Voltage and Latch.. | 194 |
| Configuring the Short key..... | 195 |
| Configuring Channel Control..... | 197 |
| Configuring the Independent Setting . | 198 |
| Configuring the Load Delay Time | 200 |
| Configuring Step Resolution | 202 |
| Configuring Response Time | 206 |
| Go/NoGo | 208 |
| Parallel Unit..... | 211 |
| View Parallel Information..... | 213 |

Accessing the Configuration Menu

Background The configuration menu is used to access instrument settings and properties as well as set the protection levels for each channel.

- Panel operation**
1. Select the channel to be configured by pressing the CHAN key and using the Selector knob.
 2. Press the F5 (Configure) key to enter the configuration (Protection) menu.

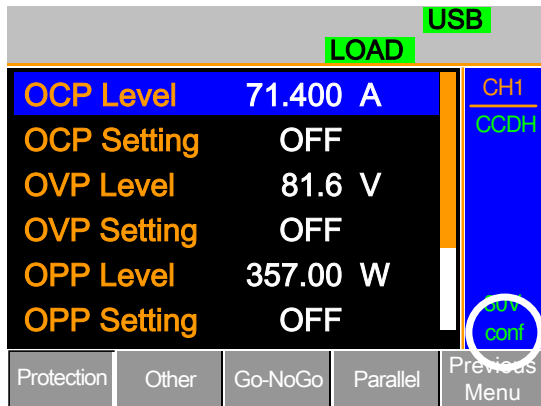
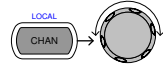

Setting (OCP/OVP/OPP/UVP)

Background Over Protection is used to set the voltage, current or power limit. In the event that the current, voltage or power exceeds the over protection settings, the load module alarm will show an error message and beep an alarm.

When tripped, Under Voltage Protection (UVP) will turn off the load. UVP trips when the load voltage drops below a set limit.

Only when the protection settings are set to On (XXP Setting -On) will the protection modes be active.

All protection settings can be set to 2% higher than specification rating.

| | | |
|------------|-------------|----------------|
| Parameters | OCP Level | 0~Rating A +2% |
| | OCP Setting | ON/OFF/Clear |
| | OVP Level | 0~RatingV+2% |
| | OVP Setting | ON/OFF/Clear |
| | OPP Level | 0~RatingW+2% |
| | OPP Setting | ON/OFF/Clear |
| | UVP Level | 0~RatingV+2% |
| | UVP Setting | Clear |

Panel operation Ensure the menu is the configuration menu. See page 186.

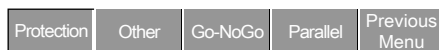

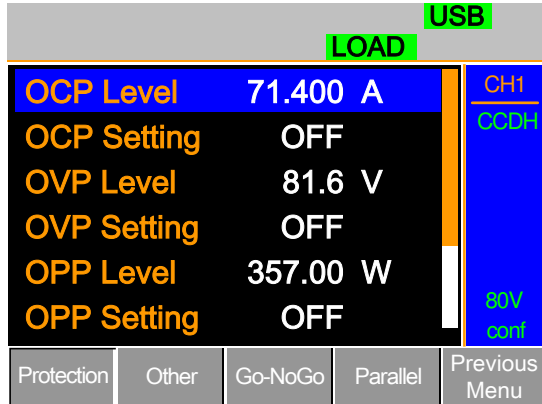

1. Use the Selector knob to highlight OCP Level.

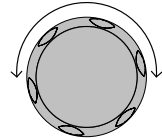

2. Press the Selector knob to edit the selected level, then turn to increase or decrease the value.

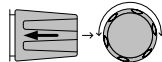

OR

3. Use the number pad to enter a number.

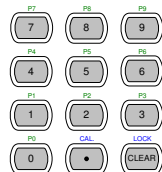

OCP Level 71.400 **A**

4. Press the Selector knob or Enter to confirm selection.



5. Use the Selector knob to highlight OCP Setting.

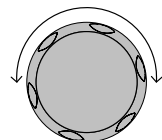

- 6. Use the selector knob to turn ON, OFF or CLEAR the OCP Setting.

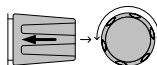

- 7. Repeat steps 1-5 for :
 - OCP Level
 - OVP Level
 - OVP Setting
 - OPP Level
 - OPP Setting
 - UVP Level
 - UVP Setting

Clearing an Alarm When any of the protection settings are tripped, Alarm will be shown on the Mainframe Status Panel and an alarm tone will sound by default.



On the local load module, the protection setting that has been tripped will be displayed.

| | | | |
|------|----------|----------|--------------|
| OCP | <i>0</i> | <i>C</i> | <i>P</i> |
| OVP | <i>0</i> | <i>U</i> | <i>P</i> |
| REV* | <i>r</i> | <i>E</i> | <i>U - U</i> |
| OPP | <i>0</i> | <i>P</i> | <i>P</i> |
| OTP* | <i>0</i> | <i>t</i> | <i>P</i> |
| CPP* | <i>C</i> | <i>P</i> | <i>P</i> |
| UVP | <i>U</i> | <i>U</i> | <i>P</i> |

- 8. Turn the load off by pressing the Load key and turn off the load input.
- 9. Change the XXP Setting to Clear to clear the alarm.

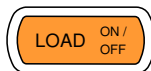

OCP Setting

Clear



Note

*REV, OTP and CPP cannot be cleared using this method, the Protection Clear function must be used instead, see page 191.

See pages 62 and 274 to output alarms via the Go/NoGo output terminal.

The configuration settings only apply to the current channel.

Protection Clear

Background

When any of the protection circuits have been tripped, the Protection Clear function can be used to reset the alarms.

Alarm will be shown on the Mainframe Status Panel and an alarm tone will sound by default when any of the protection settings are tripped.



On the local load module, the protection setting that has been tripped will be displayed.

Example: Reverse voltage protection



| | | | |
|-----|---|---|---|
| OCP | 0 | C | P |
| OVP | 0 | U | P |
| REV | r | E | U |
| OPP | 0 | P | P |
| OTP | 0 | t | P |

CPP *C P P*
 UVP *U U P*

Panel operation Ensure the menu is in the configuration menu. See page 186.



1. Turn the load off by pressing the load key if necessary.
2. Use the selector knob to scroll down to Protection Clear.

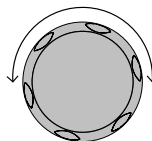

Protection Clear All

3. Press the Selector knob or Enter to clear all.

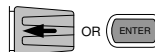

Note

The configuration settings only apply to the current channel, other channels will not be affected.

Setting the CC Voltage Range

Background The Constant Current Voltage range can be set to high or low.

Parameter CC Vrange High/Low

Panel operation Ensure the menu is in the configuration menu. See page 186.



1. Press the F2(Other) key to enter the Other menu.



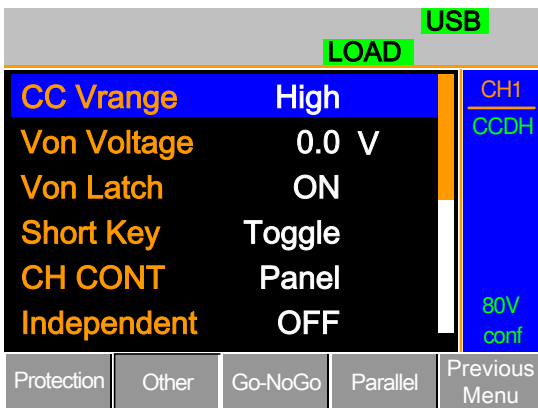

2. Use the Selector knob to highlight CC Vrange.

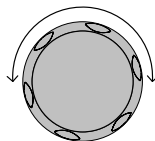

3. Press the Selector knob to edit CC Vrange, then turn to increase or decrease the range.

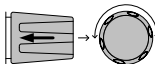

CC Vrange

High

4. Press the Selector knob or Enter to confirm selection.



The configuration settings only apply to the current channel.

Adjusting the Von Voltage and Latch

Background The Von Voltage is the voltage point at which the load module will start to sink current. When Von latch is set to ON, the load will continue to sink current after being tripped, even if the voltage drops below the Von Voltage level. The step resolution of Von Voltage is load module dependent.

Parameters Von Voltage 0.0~Rating volts
 Von Latch ON/OFF

Panel operation Ensure the menu is in the configuration menu. See page 186.



1. Press the F2(Other) key to enter the Other menu.

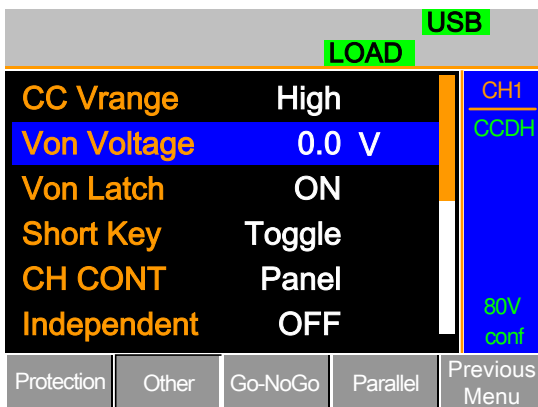

2. Use the Selector knob to highlight Von Voltage.

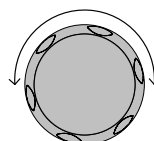

3. Press the Selector knob to edit the selected value, then turn to increase or decrease the value.

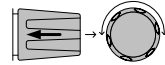

OR

Use the number pad to enter a number.

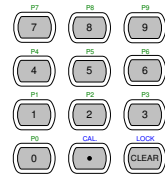

Von Voltage

0.0 V

4. Press the Selector knob or Enter to confirm selection.
5. Repeat steps 3 to 5 to turn Von Latch ON or OFF



For details about Von and Latch settings please see page 89.



Note

The configuration settings only apply to the current channel, other channels will not be affected.

Configuring the Short key

Background The Short Key is used to simulate a short circuit. The Short key can be configured to toggle (press SHORT on the load module to toggle ON or OFF) or to Hold (the SHORT key is held to short the load).

Parameter Short Key Hold/Toggle

Panel operation Ensure the menu is in the configuration menu. See page 186.



1. Press the F2(Other) key to enter the Other menu.



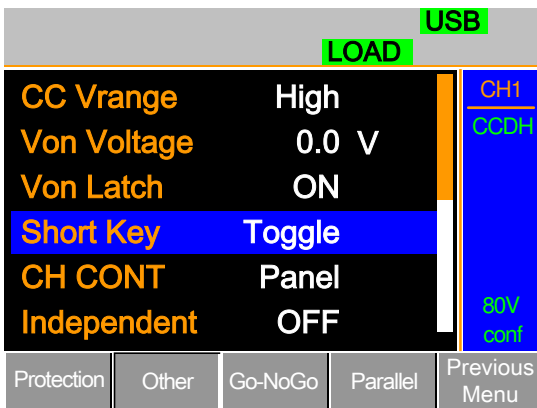

2. Use the Selector knob to highlight Short Key.

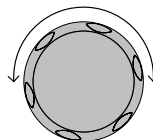

3. Press the Selector knob to edit the selected setting, turn to change the setting.

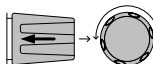

Short Key **Toggle**

4. Press the Selector knob or Enter to confirm selection.

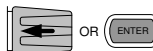

 Note

The short key can only be used when the load is on.

Configuring Channel Control

Background When Channel Control (CH CONT) is set to External, it will disable editing the active channel load. Instrument buttons and knobs can still be used to access the menu for the active channel or to edit other channels that do not have channel control active. This prevents settings on the active channel from being changed on the local machine. See pages 59 & 93 for details.

Parameter CH CONT Panel/External

Panel operation Ensure the menu is in the configuration menu. See page 186.



1. Press the F2(Other) key to enter the Other menu.

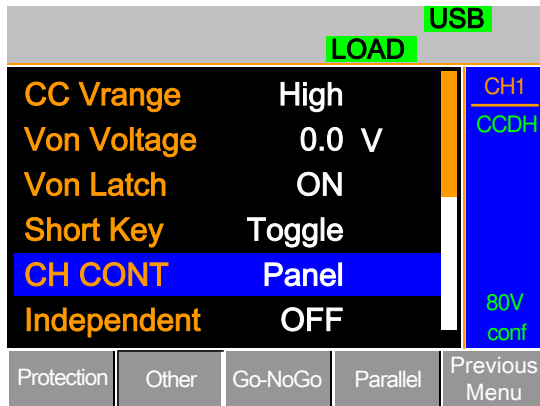

2. Use the Selector knob to highlight CH CONT.

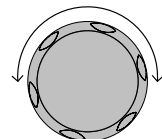

3. Press the Selector knob to edit the selected setting, turn to change the setting from Panel to External.

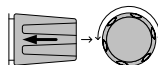

CH CONT External

4. Press the Selector knob or Enter to confirm selection.



Channel control is now activated. To turn Channel Control off, CH CONT must be set to Panel again. When Channel Control is active, EXT will be displayed on the side panel for the active channel.



Note

Channel Control can only be activated on the active channel; other channels will not be affected.

Configuring the Independent Setting

Background

The Independent setting allows a channel to be load independent from the mainframe. What this means is that a load module with Independent set to ON can only load from the local load module. If the LOAD ON/OFF key is pressed from the mainframe, the channel with Independent set to ON will be unaffected by the mainframe, except when running a program.

| | | |
|-----------|-------------|---------|
| Parameter | Independent | ON/ OFF |
|-----------|-------------|---------|

Panel operation Ensure the menu is in the configuration menu. See page 186.

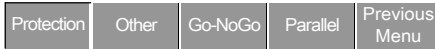

1. Press the F2(Other) key to enter the Other menu.

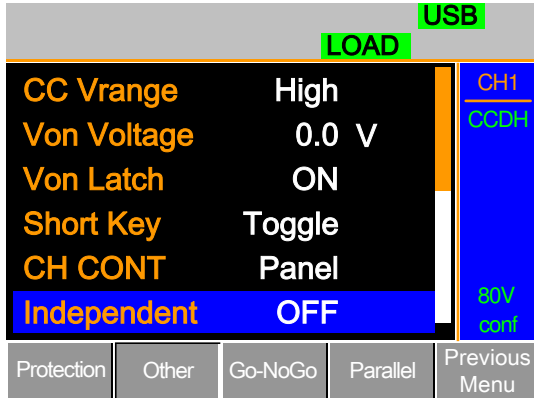

2. Use the Selector knob to highlight Independent.

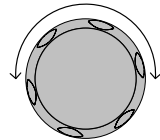

3. Press the Selector knob to edit the selected setting, turn to change the setting.

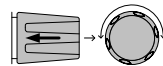

4. Press the Selector knob or Enter to confirm selection.

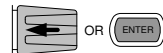

When a channel has been set to independent, an asterisk(*) will be shown next to the channel number indicator in the Current Operation Channel Status panel.



The configuration settings only apply to the current channel, other channels will not be affected.

Configuring the Load Delay Time

Background The mainframe can delay loading a channel by up to 10 seconds. However the Delay Time is only applicable for manual loading. Delay Time is not applicable to Programs or Sequences.

Parameter Load D-Time 0~10 S

Panel operation Ensure the menu is the configuration menu. See page 186.



1. Press the F2(Other) key to enter the Other menu.



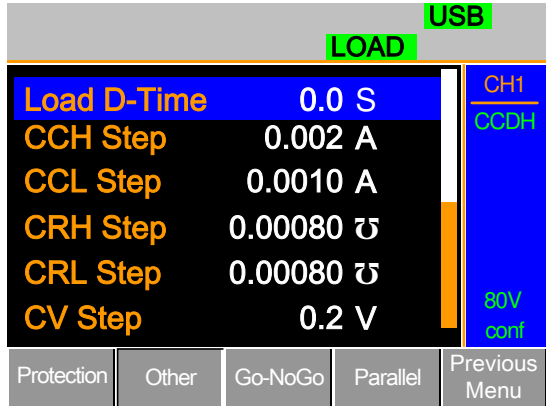

2. Use the Selector knob to highlight Load D-Time.

Note: Load D-Time is below Independent, off-screen.

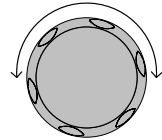

3. Press the Selector knob to edit the selected setting, turn to change the setting.

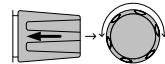

OR

Use the number pad to enter a number.

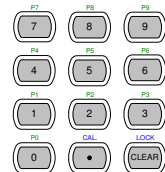

Load D-Time **0.0 S**

4. Press the Selector knob or Enter to confirm selection.

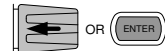

Note

The Delay Time only applies to the current channel; other channels will not be affected.

Delay time only applies when the load is manually turned on or during start up with the Auto Load On setting (page 217).

Configuring Step Resolution

Background The CC, CV and CR step resolution settings can be edited in the configuration menu. These step resolution settings directly correspond to the step resolution of the coarse adjustment when setting the CC, CR and CV parameters.

The minimum and maximum step resolution that can be set for each channel is dependent on the load module. For more information on step resolution see page 89.

| Step Resolution | | Minimum* | Maximum* | Unit |
|-----------------|----------|----------|----------|-----------|
| PEL-2020A | CCH Step | HR/20000 | HR/2 | Amperes A |
| | CCL Step | LR/20000 | LR/2 | Amperes A |
| | CRH Step | HR/40000 | HR/2 | Siemens Ω |
| | CRL Step | LR/40000 | LR/2 | Siemens Ω |
| | CVH Step | HR/40000 | HR/2 | Voltage V |
| | CVL Step | LR/40000 | HR/2 | Voltage V |
| | CPH Step | HR/10000 | HR/2 | Watt W |
| | CPL Step | LR/10000 | LR/2 | Watt W |
| PEL-2030A (L) | CC Step | R/40000 | LR/2 | Amperes A |
| | CRH Step | HR/40000 | HR/2 | Siemens Ω |
| | CRL Step | LR/40000 | LR/2 | Siemens Ω |
| | CVH Step | HR/40000 | HR/2 | Voltage V |
| | CVL Step | LR/40000 | HR/2 | Voltage V |
| | CPH Step | HR/30000 | HR/2 | Watt W |
| | CPL Step | LR/30000 | LR/2 | Watt W |

| | | | | |
|---------------|----------|----------|------|-----------|
| PEL-2030A (R) | CCH Step | HR/40000 | HR/2 | Amperes A |
| | CCL Step | LR/40000 | LR/2 | Amperes A |
| | CRH Step | HR/40000 | HR/2 | Siemens Ū |
| | CRL Step | LR/40000 | LR/2 | Siemens Ū |
| | CVH Step | HR/40000 | HR/2 | Voltage V |
| | CVL Step | HR/40000 | HR/2 | Voltage V |
| | CPH Step | HR/25000 | HR/2 | Watt W |
| | CPL Step | LR/25000 | LR/2 | Watt W |
| PEL-2040A | CCH Step | HR/35000 | HR/2 | Amperes A |
| | CCL Step | LR/35000 | LR/2 | Amperes A |
| | CRH Step | HR/40000 | HR/2 | Siemens Ū |
| | CRL Step | LR/40000 | LR/2 | Siemens Ū |
| | CVH Step | HR/40000 | HR/2 | Voltage V |
| | CVL Step | LR/40000 | HR/2 | Voltage V |
| | CPH Step | HR/35000 | HR/2 | Watt W |
| | CPL Step | LR/35000 | LR/2 | Watt W |
| PEL-2041A | CCH Step | HR/20000 | HR/2 | Amperes A |
| | CCL Step | LR/20000 | LR/2 | Amperes A |
| | CRH Step | HR/40000 | HR/2 | Siemens Ū |
| | CRL Step | LR/40000 | LR/2 | Siemens Ū |
| | CVH Step | HR/50000 | HR/2 | Voltage V |
| | CVL Step | LR/50000 | HR/2 | Voltage V |
| | CPH Step | HR/35000 | HR/2 | Watt W |
| | CPL Step | LR/35000 | LR/2 | Watt W |

* HR = High range, LR = Low range

**Note**

Use the Shift key to toggle between coarse and fine adjustment mode when editing the CC, CR and CV values with the Selector knob on the main display. The fine adjustment resolution varies between the function and load module used.

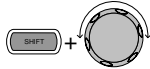
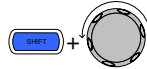
Coarse mode:**Fine mode:**

Panel operation Ensure the menu is the configuration menu. See page 186.



1. Press the F2(Other) key to enter the Other menu.

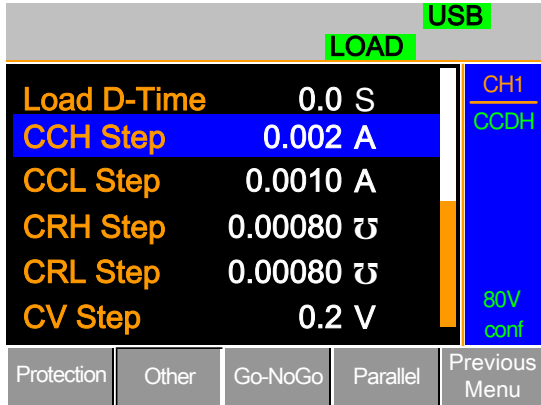

2. Use the Selector knob to scroll down to highlight CCH Step.

Note: CCH Step is off-screen when entering Other menu.

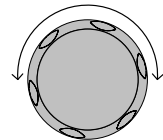

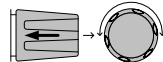

3. Press the Selector knob to edit the selected setting, turn to change the setting.

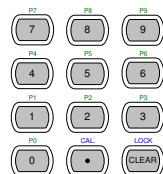

OR

Use the number pad to enter a number.



4. Press the Selector knob or Enter to confirm selection.  OR 
5. Repeat steps 2-4 to edit the step resolution of:
 - CCL Step
 - CRH Step
 - CRL Step
 - CV Step



Note

The Step resolution settings only apply to the active channel, other channels will not be affected.

Configuring Response Time

Background The Response time setting is used in CV mode to limit current draw. The Response setting sets the bandwidth of the load generator to Fast (1MHz) or as Normal (100kHz).

| | | |
|-------------------|----------|--------------|
| Parameters | Response | Normal, Fast |
|-------------------|----------|--------------|

Panel operation Ensure the menu is the configuration menu. See page 186.



1. Press the F2(Other) key to enter the Other menu. 

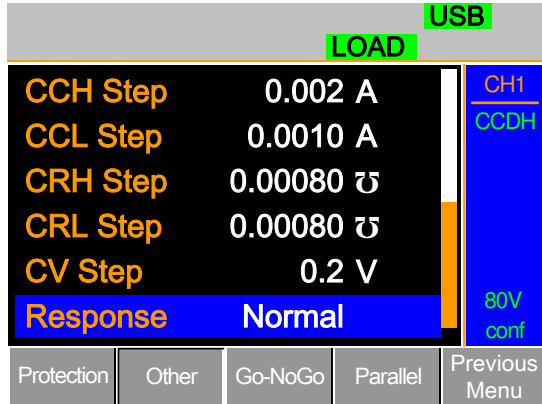

2. Use the Selector knob to scroll down to highlight Response.

Note: Response is off-screen when entering Other menu.

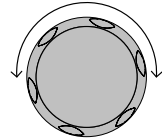

3. Press the Selector knob to edit the selected setting, turn to change the setting.

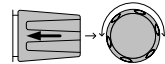

4. Press the Selector knob or Enter to confirm selection.



Note

The Response settings only apply to the active channel, other channels will not be affected.

Go/NoGo

Background Go/NoGo mode is used to set threshold limits. When a load is within the limit(s) it is considered to be “Go”, when the load has exceeded the limit it is considered to be “NoGo”.

Go/NoGo limits can be set as either absolute values (Entry Mode set to “Value”) or as a percentage offset from a nominal (Center) value (Entry Mode set to “Percent”).

Go/NoGo can be used in both high and low ranges, as well as CC, CV, and CR modes. The Go/NoGo status can be read using the rear Go/NoGo output.

A delay time can also be imposed for up to 1 second.



Note

Any Go/NoGo configuration only applies to the current channel with the same mode and range.

| Parameters | Value | Percent |
|------------|-----------------|---------------------|
| CC Mode | High: V | High: % |
| CR Mode | Low: V | Low: % Center: V |
| CV Mode | High: A | High: % |
| CP Modde | Low: A | Low: % Center: A |
| Delay Time | 0.0~1.0 seconds | |

Panel Operation Ensure the menu is in the Configuration menu. See page186.



Choose Absolute/ Percentage limits 1. Press (F3) Go-NoGo to access the Go/NoGo menu.



2. Use the selector knob to edit Entry Mode.

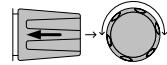

3. Choose Value for absolute limits or Percent for percentage offset limits.

Entry Mode Value

Or

Entry Mode Percent

4. The menu changes according to the selection.

Value

Percent

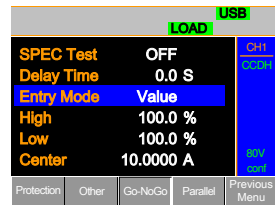
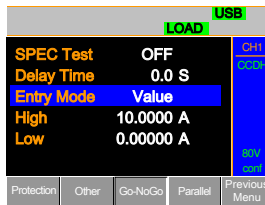

5. Use the Selector knob and number pad to edit Delay time, High, Low and Center (Percent mode only).

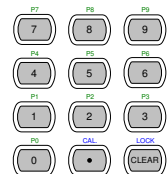
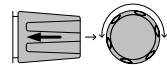

6. Press the selector knob or Enter to confirm each value.



Turn Go/NoGo On/Off

7. Use the Selector knob to edit Spec Test.

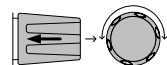

- 8. Choose ON to turn on Go/NoGo.



- 9. Choose OFF to turn off Go/NoGo.



When SPEC test is set to ON, SPEC will be displayed in the Current Operation Channel Status panel.



Parallel Unit

Background The Parallel Unit Configuration menu allows load modules of the same type and rating to be configured as a single unit when used in parallel. Up to 4 load modules can be used in this mode.

Operating the PEL-2000A load modules in Parallel Unit mode is almost identical to using the load modules separately. The only difference is that the channel configuration only needs to be setup for channel 1 and not individually for each channel.

There are two mode types: Para and Sync. The Para setting allows the all the parallelized load modules to be operated as a single large load module. Sync mode allows the settings of a single unit to be synchronized across all the other parallelized load modules.

The Display Mode will determine which parameters are displayed on the local load modules.



Note

Only CC or CR mode can be used in parallel mode.

Ensure the same firmware used for both units.

| | | |
|------------|---------------|----------------------|
| Parameters | Parallel Unit | 2/3/4/OFF |
| | Parallel Mode | Para/Sync |
| | Display Mode | V,I / ,V,W / I,W / S |

- Panel Operation**
1. Ensure channel 1 is selected as the active channel. Page 132
 2. Ensure the menu is in the Configuration menu. See page186.



Parallel Setup

3. Press (F4) Parallel to access the Parallel menu.

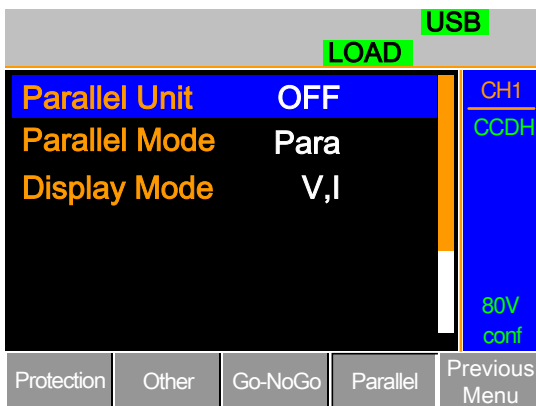

4. Use the Selector knob to change Parallel Unit from the OFF setting to the number of parallel units.

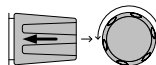

5. Press the selector knob or Enter to confirm.



Parallel Mode

6. To change the type of mode, use the Selector knob to edit Parallel Mode.
7. Choose Para to operate the units as a single large load module, or choose Sync to synchronize the load settings across each parallel unit.

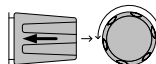

- Display Mode
- Use the selector knob to change the display settings on the local load modules.
 - Choose from V, I / V, W / I, W or S.

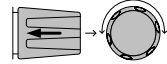

Display Mode **V, I**

When Para Unit is active, an indicator will be displayed on the screen. The indicator depends on the Parallel Mode. P will be displayed for Para Mode and S will be displayed for Sync Mode.

| | |
|------|-----------|
| CHXP | Para Mode |
| CHXS | Sync Mode |



The PEL-2000A is now ready to operate in Parallel Mode.

- Turn Parallel Mode Off
- To disable Parallel Mode, use the selector knob to change Para Unit to OFF.

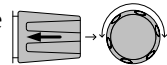



Parallel Unit **OFF**

View Parallel Information

Background The overall parallel settings can be viewed in the Function menu.



| | | |
|-----------------------|---------|--|
| Parameter Description | Main Ch | The channel number used for Parallel Unit mode |
| | Number | The number of mainframes used. |

| | |
|--|---|
| Mode | Mode and Range. CCL, CCH, CRL, CRH |
| VRange | High, Low |
| L1,L2 | Level 1, Level 2 settings (Dynamic mode only) |
| SR  | Rising slew rate settings |
| SR  | Rising slew rate settings |
| T1 | Timer 1 (Dynamic mode only) |
| T2 | Timer 2 (Dynamic mode only) |

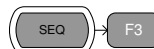
- Panel Operation 1. Press the FUNC key then F3 (Parallel) to access the viewable Parallel settings.



The current Parallel Unit mode settings are shown below.

| | | LOAD | | USB |
|-----------------|------|---|---------|-----|
| Main Ch: | 1 | L1: | 0.0000 | |
| Number: | 1 | L2: | 0.0000 | |
| Mode: | CCH | SR  : | 2.80000 | |
| VRange | High | SR  : | 2.80000 | |
| | | T1: | 0.00003 | |
| | | T2: | 0.00003 | |

- Parallel Mode 2. To exit the parallel settings, press any one of the System keys (CHAN, FUNC, FILE or HELP)

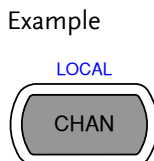

Mainframe Configuration

The Mainframe Configuration chapter describes configuration settings that apply to all channels and general interface settings.

| | |
|---------------------------------------|------------|
| Mainframe Configuration | 215 |
| Accessing System Information | 216 |
| Accessing the Load Menu | 217 |
| Adjusting the Speaker | 218 |
| Adjusting the display settings | 219 |
| Adjusting the Frame Control | 221 |
| Adjusting the Knob Control Type | 223 |
| Configuring Alarm Sound | 224 |
| Configuring Go/NoGo Alarm Sound .. | 225 |
| Adjusting Slave Knob Settings | 227 |
| View Language Settings | 229 |

Accessing System Information

| | |
|------------|---|
| Background | The System Information displays the mainframe and load module(s) serial numbers. |
| Parameters | <p>MainFrame Ver: Mainframe firmware version and date (month/ day).</p> <p>PEL-200X SN: Mainframe Serial number.</p> <p>SlotX(Y)Ver: The version number of the Xth load module occupying the Xth slot with channel number Y.</p> <p>PEL-20XX SN: The serial number and module model of the Xth load module</p> <p>Y designates the first channel of each installed load module. For example if two dual channel load modules are installed, then Ch1&3 will be used for the firmware and serial number.</p> |

- Panel operation
1. Press the Shift Key then the Help key to access the Utility menu/System Info menu.

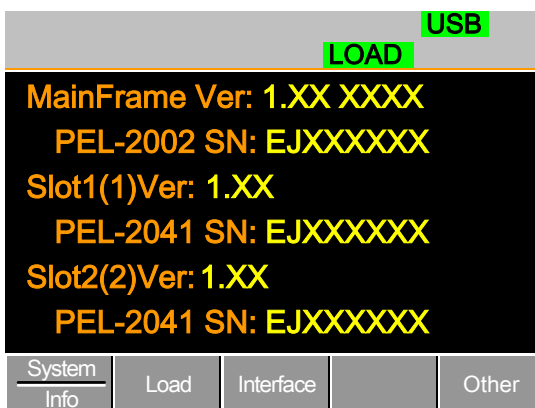
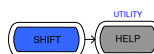



Accessing the Load Menu

Background The PEL series is able to automatically start loading from the last program or load setting.

If Auto Load On is set to Load, the last load setup used before the machine was reset will automatically start to load upon startup.

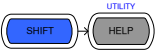

If Program is set as the Auto Load On configuration, the last program executed will start upon the next start up.

Parameters Auto Load ON/OFF
 Auto Load On Load/Program

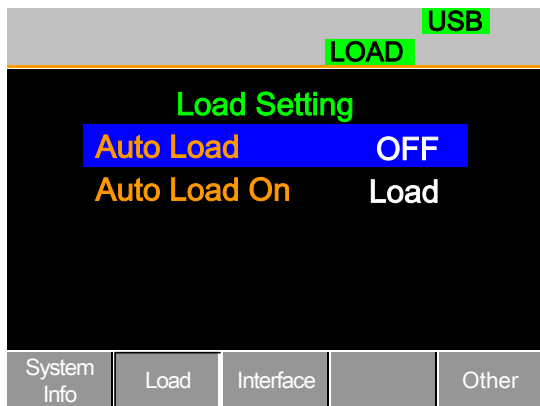
- Panel operation**
1. Press the Shift Key then the Help key to access the Utility menu. 
 2. Press F2 (Load). 

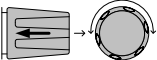



3. Press the Selector knob, then turn to choose Auto Load. 

4. Press the Selector knob or Enter  OR 
5. Scroll to Auto Load On and choose Load or Program for the next time the PEL-2000A starts up.

Adjusting the Speaker

Background The PEL series has an internal speaker for both the mainframe and load modules. The speaker function turns On/Off the sound for the UI (key presses and scrolling). The speaker setting will not alter the sound for protection alarms or Go/NoGo alarms.

Parameter Speaker ON/OFF

- Panel operation**
1. Press the Shift Key then the Help   to access the Utility menu.
 2. Press F5 (Other Menu). 

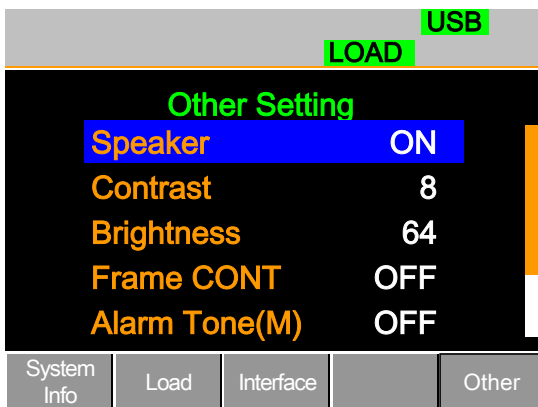

- Use the Selector knob to highlight Speaker.

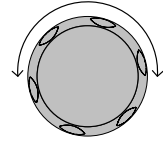

- Press the Selector knob to edit Speaker, then turn to change from On to Off and vice versa.

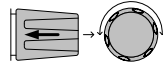

Speaker

ON

- Press the Selector knob or Enter to confirm selection.

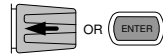

Adjusting the Display Settings

Background The PEL series has a TFT LCD display. The display brightness and contrast can be controlled via the utility menu.

| | | | | |
|-------------------|-------------------|-------|---------|------------|
| Parameters | Brightness | 50~90 | 50(low) | 90(bright) |
| | Contrast | 3~13 | 3(low) | 13(high) |

- Press the Shift Key then the Help key to access the Utility menu.

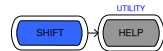

- Press F5 (Other Menu).



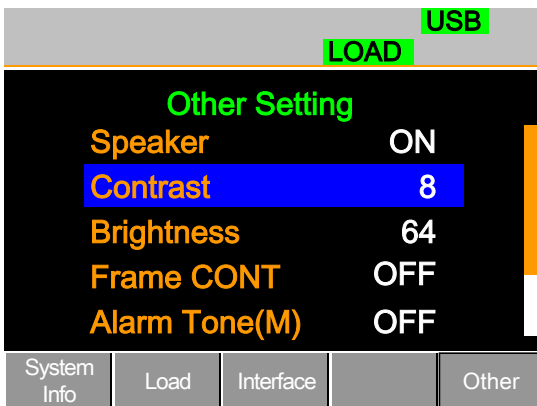

- Use the Selector knob to highlight Contrast.

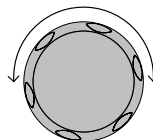

- Press the Selector knob to edit contrast, then turn to increase or decrease the value.

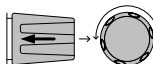

Contrast 8

- Press the Selector knob or Enter to confirm selection.

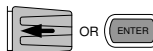

- Repeat steps 3-5 for the Brightness.

Adjusting the Frame Control

Background Frame control is used to control a number of different frame linked mainframes (slaves) with a master mainframe. For information on frame control, frame control interface and connection see pages 57 & 271.

Note: When using frame control, ensure the same firmware is installed in both master and slave units.

- Panel operation**
1. Connect the mainframes using a frame link connection. Page 57.
 2. On the master mainframe, press the Shift Key then the Help key to access the Utility menu.
 3. Press F5 (Other Menu).

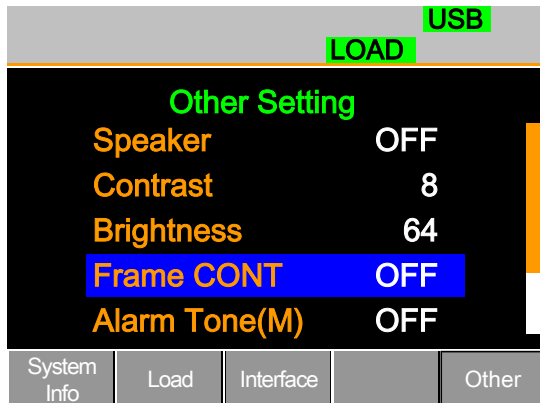
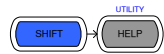

- Use the Selector knob to highlight Frame CONT.

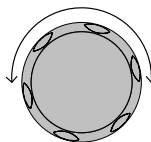

- Press the Selector knob to edit, then turn to turn Frame CONT (frame control) ON or OFF.

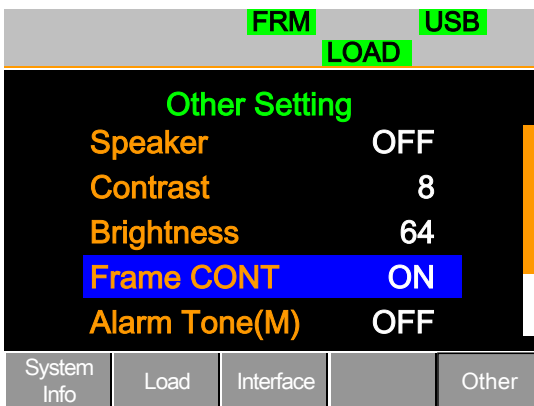
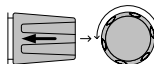

When Frame CONT is set to ON the mainframe will display FRM (Master) or FRS (Slave) on the top of the display.

- Repeat the above steps for any connected slave mainframe units.

Frame control is now ready for both master and slave mainframes.



Adjusting the Knob Control Type

Background The load module control knobs can be set to operate independently to the mainframe.

With the Knob type set to Updated, dependent operation is activated. Both the local (load module) selector knob and mainframe selector knob can change the resistance (CR mode), current (CC mode), voltage (CV mode) and power (CP mode). Changes from local mode are updated on the mainframe and vice versa.

With the Knob type set to Old, independent operation is activated. Local operation changes do not change the setting/ values on the mainframe.

Parameter Knob Type Updated/Old

- Panel operation**
1. Press the Shift Key then the Help key to access the Utility menu.  
 2. Press F5 (Other Menu). 

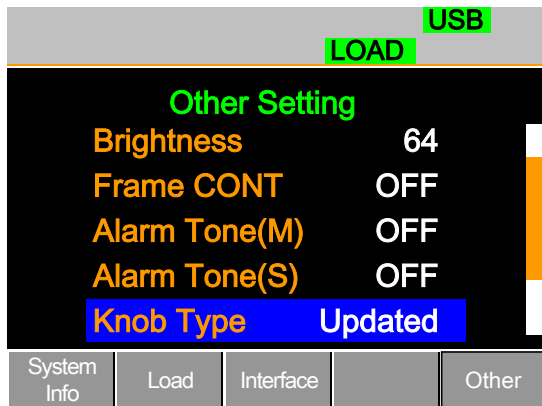

- Use the Selector knob to move the cursor down to Knob Type (below the initial screen).

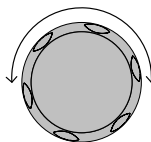

- Press the Selector knob to highlight Knob Type, then turn to change to Old/Updated.

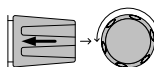

Knob Type Updated

- Press the Selector Knob or Enter to confirm selection.

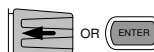

Configuring Alarm Sound

Background

The PEL series has two different types of alarms, one located on the mainframe (Alarm Tone M) and one for each load module (Alarm Tone S).

Alarm Tone(M)/(S) can individually be set ON or OFF.

Panel operation

- Press the Shift Key then the Help key to access the Utility menu.
- Press F5 (Other Menu).

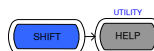

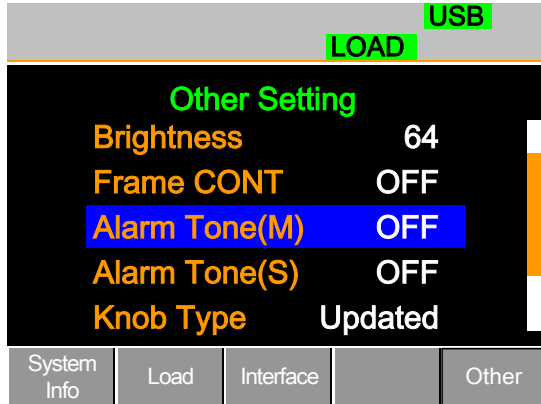

3. Use the selector knob to highlight Alarm Tone(M)

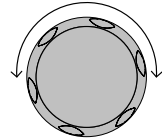

4. Press the Selector knob to select the master alarm (Alarm Tone(M)), turn to edit and press to confirm selection.

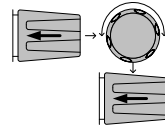

Alarm Tone(M) ON

5. Repeat the steps to edit the slave alarm (Alarm Tone(S)).

Configuring Go/NoGo Alarm Sound

Background When any Go/NoGo limits are tripped from any channel, a tone can be set as an alarm.

The Go_NoGo tone alarm settings apply to all channels.

Parameter Go_NoGo Tone ON/OFF

Panel operation 1. Press the Shift Key then the Help key to access the Utility menu.

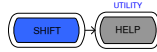

2. Press F5 (Other Menu).

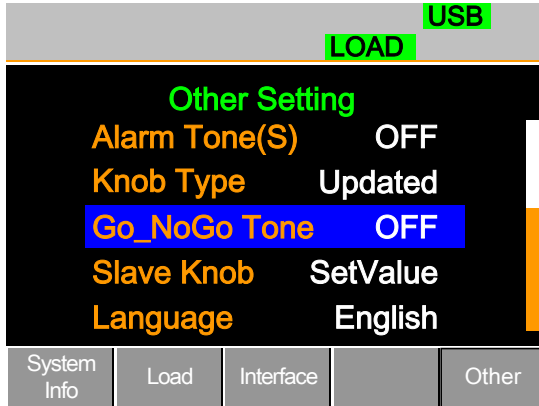

3. Use the Selector knob to move the cursor down to Go_NoGo Tone (below the initial screen).

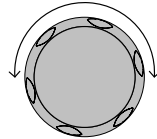

4. Press the Selector knob to highlight Go_NoGo Tone, then turn to change to ON/OFF.

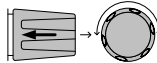

5. Press the Selector Knob or Enter to confirm selection.



Adjusting Slave Knob Settings

Background Channel loads can be edited using the local load module or the Mainframe. When using the slave knob to edit a load, the load module display can be set to two different types: SetValue and Measured.

When a load is ON, SetValue will always display the set value (A Value, B Value) on the local load module display whilst "Measure" will show the actual measured value when editing the load. These settings apply to all channels.

The "Measure" setting can be temporarily disabled by pressing the Slave Knob to display the "SetValue" instead of the "Measure" value in the local load module display.

Parameter Slave Knob Measure/SetValue

- Panel operation**
1. Press the Shift Key then the Help key to access the Utility menu.
 2. Press F5 (Other Menu).

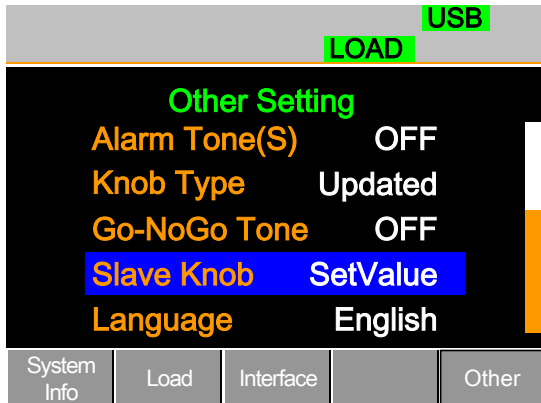
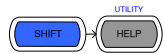

3. Use the Selector knob to move the cursor down to Slave Knob (below the initial screen).

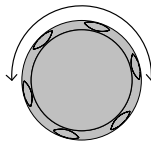

4. Press the Selector Knob to highlight Slave Knob, then turn to change to Measure/SetValue.

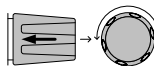

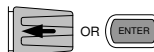

Slave Knob **SetValue**

5. Press the Selector Knob or Enter to confirm selection.

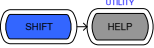

View Language Settings

Background The language settings can be viewed in the Utilities menu.

- Panel operation**
1. Press the Shift Key then the Help key to access the Utility menu. 
 2. Press F5 (Other Menu). 

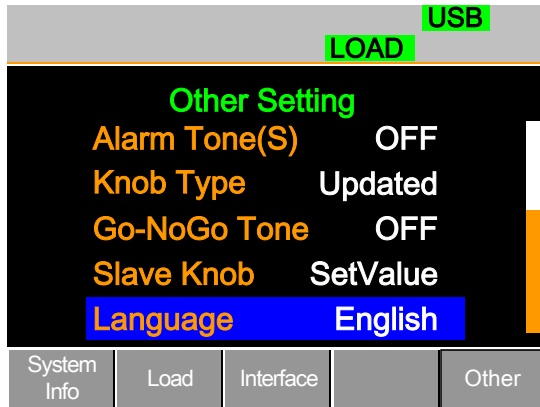

3. Use the Selector knob to move the cursor down to Language (below the initial screen).

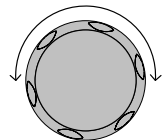

Interface Configuration (settings)

The Interface Configuration chapter describes configuration settings that apply when using the PEL-2000A with a remote connection. There are three interface options for remote control: RS232, GPIB and USB. Only one interface can be used at a time. For more details about remote control and interface connections, see the Interface section on page 267.



| | |
|--|------------|
| Interface Configuration (settings)..... | 230 |
| Configuring RS232 Connection..... | 231 |
| Configuring the GPIB Address..... | 233 |
| Configuring USB Remote Connection. | 234 |

Configuring RS232 Connection

Background When using RS232 a number of parameters need to be set. These include Baud rate, Stop Bit and Parity. When setting RS232 parameters, ensure they match that of the host machine.

Parameters

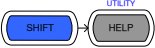
| | |
|-----------|----------------------------|
| Baud Rate | 2400/4800/9600/19200/38400 |
| Stop Bit | 1~2 |
| Parity | None/Odd/Even |

- Panel operation**
1. Press the Shift Key then the Help key to access the Utility menu. 
 2. Press F3(Interface Menu). 

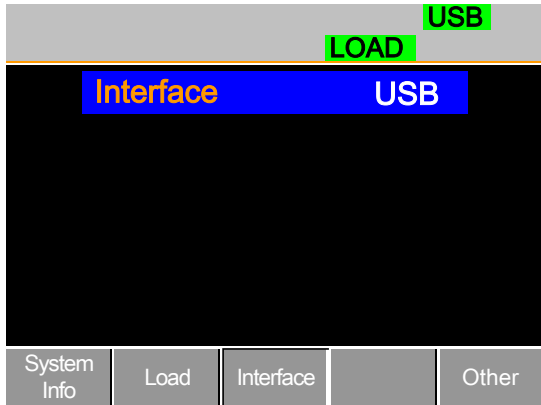

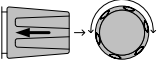
3. If the Interface mode is not RS232, use the Selector knob to edit Interface. 
4. Choose RS232.



5. Press the Selector knob to confirm.
6. The RS232 Menu appears.

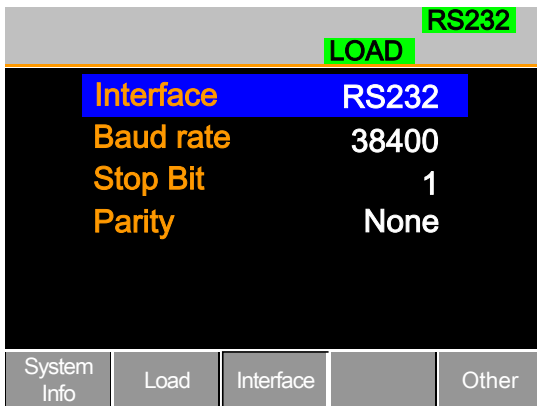

7. Use the Selector knob to edit Baud rate, Stop Bit and Parity.

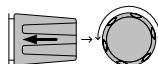



 **Note**

The Baud Rate, Stop Bit and Parity must match that of the host machine.

Configuring the GPIB Address

Background When using GPIB, an address must be specified.

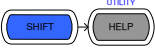
Parameters Address 01~30

- Panel operation**
1. Press the Shift Key then the Help key to access the Utility menu. 
 2. Press F3(Interface Menu). 

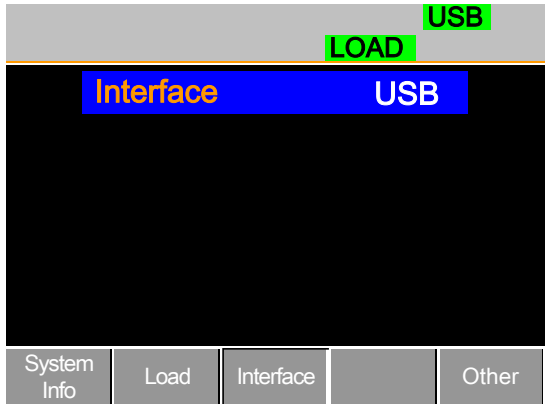

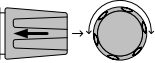

3. If the Interface mode is not GPIB, use the Selector knob to edit Interface. 
4. Choose GPIB.

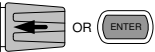

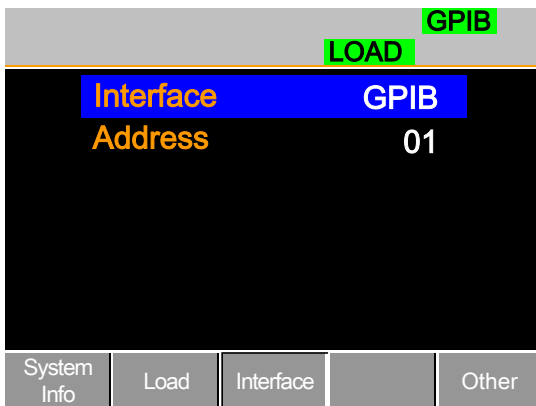
5. Press the Selector knob or Enter to confirm selection. 
6. The GPIB menu appears.



- Use the selector knob to edit the GPIB address.  OR 





Note

The GPIB Address must match that of the host machine.

Configuring USB Remote Connection

Background Of the three interface options, USB is the easiest to use.

Panel operation 1. Press the Shift Key then the Help key to access the Utility menu.  → 

2. Press F3(Interface Menu). 

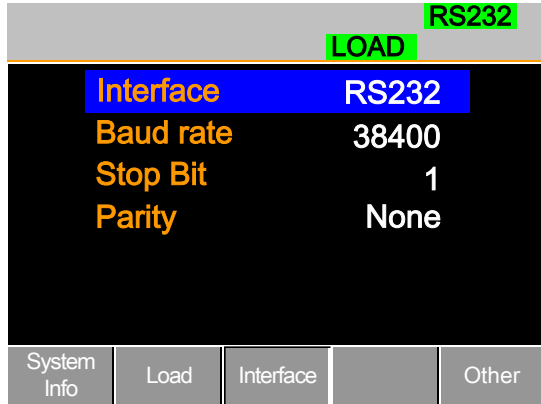

3. If the Interface mode is not USB, use the Selector knob to edit Interface.

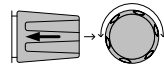

4. Choose USB.

Interface

USB

5. Press the Selector knob to confirm.



6. The Interface will become USB.

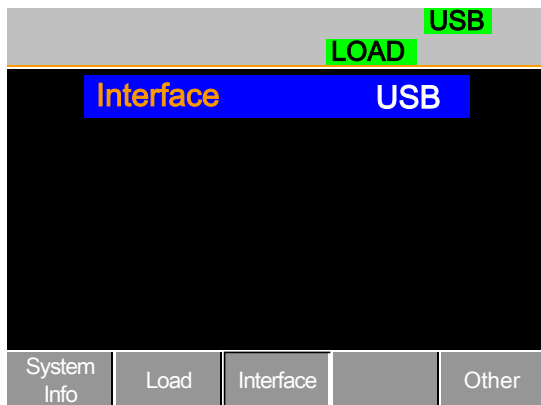

Save / Recall

| | |
|---|------------|
| Save / Recall | 236 |
| Saving/Recalling Channels | 237 |
| Saving/Recalling Preset memory | 239 |
| Saving/Recalling Setup Memory | 241 |
| Setting the Default USB Path/File | 243 |
| Saving Setups to USB Memory | 248 |
| Saving/Recalling Memory Data to USB | 251 |
| Saving/Recalling Presets to USB | 255 |
| Saving/Recalling Sequences to USB ... | 259 |
| Quick Preset Recall/Save | 263 |
| Recall Setup Memory (Frame link). | 264 |
| Recall Preset Memory (Frame link) | 265 |
| Recall Factory Defaults | 266 |

Saving/Recalling Channels

Background The PEL-2000A series can save data for up to 120 different channel configurations. Each channel is represented by 120 memory slots using the onboard memory.

Memory is used in program sequences or for individual channel setups. For further details on memory, see page 97.

Panel operation 1. Press the File key.



2. Press F1 repeatedly until the Media Memory menu appears.

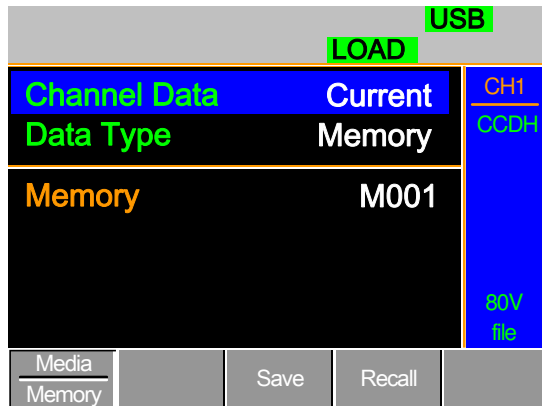
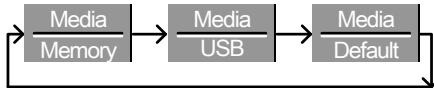

3. Use the Selector Knob to edit Channel Data and Data Type.

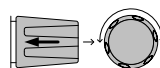

4. Choose Current and Memory.

| | |
|--------------|---------|
| Channel Data | Current |
| Data Type | Memory |

5. Press the Selector knob to edit Memory (M001-M120)

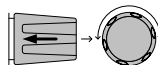

OR

Use the number pad to enter a number.



6. Press F3 to Save or F4 to Recall the memory settings.

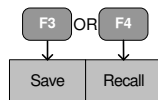

7. A message will indicate when a save has been successful

Memory No 001 Save OK



Note

The display will revert to the channel menu after recalling memory. Remember the memory is only saved/recalled for the current channel.

Saving/Recalling Preset memory

Background The PEL-2000A series can store up to 10 presets for each channel. The presets can be saved or recalled either individually for each channel (Channel Data: Current) or at the same time (Channel Data: All), using the All option.

For further details on memory, see page 97.

Panel operation 1. Press the File key.



2. Press F1 repeatedly until the Media Memory menu appears.

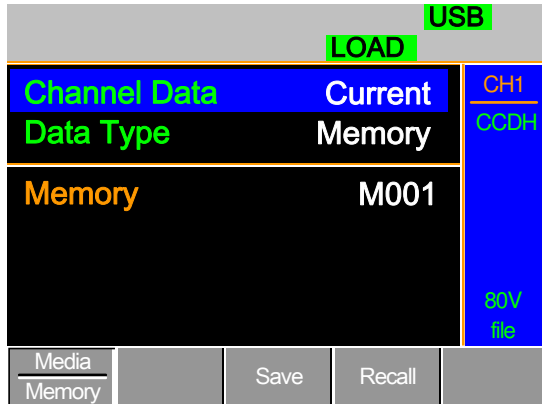
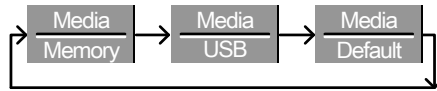

3. Use the Selector Knob to edit Channel Data and Data Type.

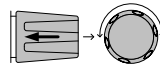

4. To save or recall only the active channel, choose Current and Preset. To save or recall all the presets choose All and Preset.

Save / Recall
Current Channel

| | |
|--------------|---------|
| Channel Data | Current |
| Data Type | Preset |

Save / Recall All
Channels

| | |
|--------------|--------|
| Channel Data | All |
| Data Type | Preset |

5. Press the Selector knob to edit Preset (P0-P9)

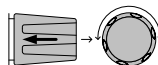

OR

Use the number pad to enter a number.



6. Press F3 to Save or F4 to Recall the Presets.

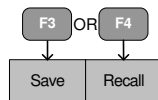

7. A message will be displayed when the save is complete.

Preset P0 Save OK



Note

The display will revert to the channel menu after recalling memory.

Saving/Recalling Setup Memory

Background The PEL-2000A series can store up to 4 different setups using the onboard memory. Each setup can be saved from the file menu. Using Setup Memory, each channel will be saved. For further details on memory, see page 97.

Panel operation 1. Press the File key.



2. Press F1 repeatedly until the Media Memory menu appears.

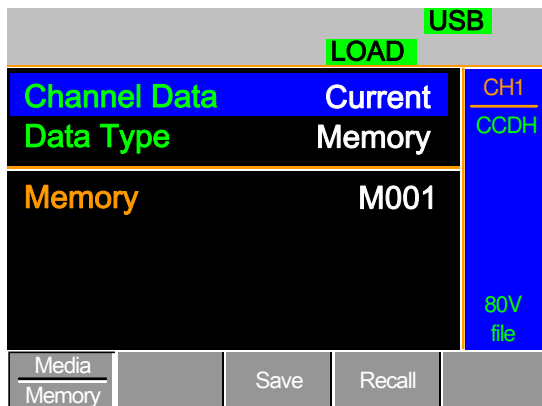
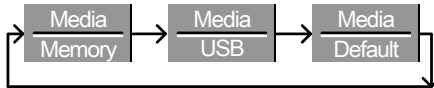

3. Use the Selector Knob to edit Channel Data and Data Type.

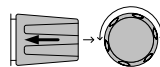

4. Choose All and Setup.



5. Press the Selector knob to edit Setup Memory (1~4)

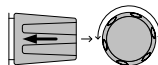

OR

Use the number pad to enter a number.

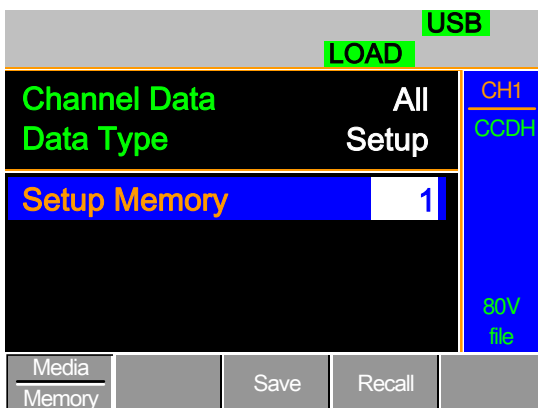

6. Press F3 to Save or F4 to Recall the Setup Memory.

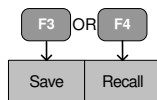



7. A message will be displayed when the save/recall is complete.

Setup Memory 1 Save OK
Setup Memory 1 Recall OK

Setting the Default USB Path/File

Background When saving files to a USB memory stick the files will be saved into the root directory if a file path has not been set.

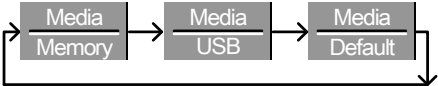
- Panel operation**
1. Insert a USB flash drive into the front panel USB slot. 
 2. Press the File key. 
 3. Press F1 repeatedly until the Media USB menu appears. 
- 

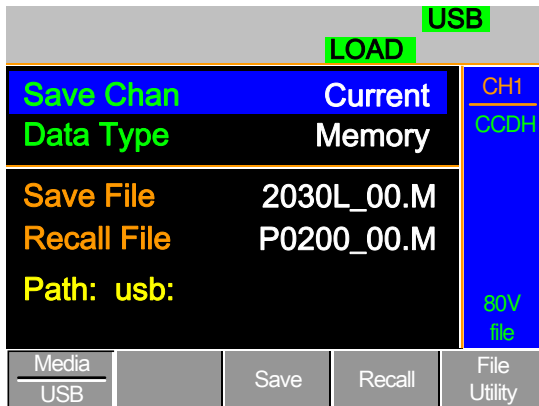

4. Press F5 (File Utility). 

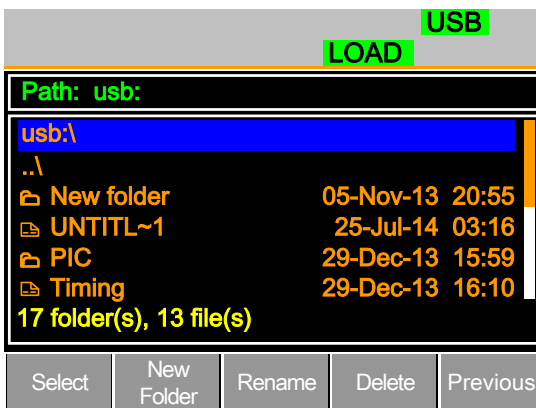

The top section (window) shows the current USB path.

There are 5 options:

- **Select**; Selects the current USB path as the default file path to save. (Step 5)
- **New Folder**; Creates a new folder (Step 7)
- **Rename**; Renames the current folder/path (Step 13)
- **Delete**; deletes the current file/path name. (Step 20)

Select Default Path

5. Use the Selector knob to highlight the new path directory

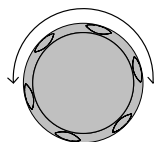

6. Press F1(Select) to select the new default directory path.



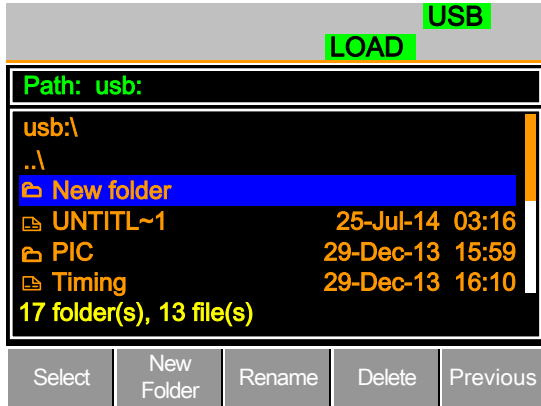

The new path will be shown in the upper Path box in green.



Create New Folder

- To create a new directory, Press F2(New Folder)



The On-Screen keyboard (OSK) appears. The directory has an 8 character size limit.

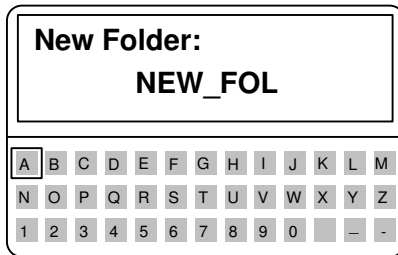

- Use the Selector knob to scroll left and right through the keys.

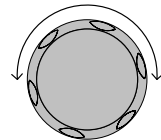

9. When a key is highlighted, use the selector knob, F1 or Enter to confirm a key entry.

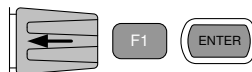

10. Use F2 (Back Space) to delete any previous entries/mistakes.



11. Press F3 (Save) to save the directory name.



12. Press F5 (Previous menu) to continue to the previous menus



Rename Folder

13. Use the Selector knob to highlight the file/directory that needs to be renamed.

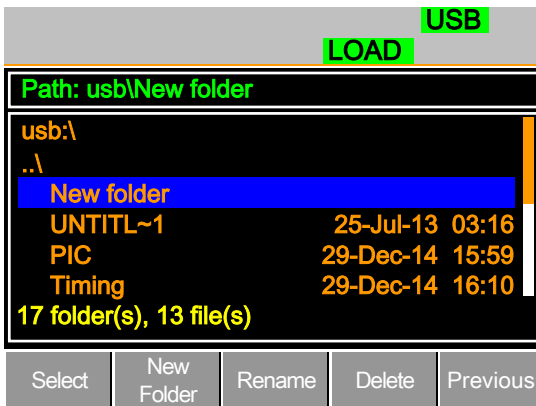
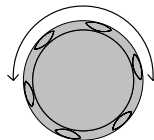

14. Press F3(Rename)



The On Screen Keyboard appears



15. Use the Selector knob to scroll left and right through the keys.

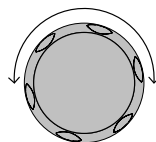

16. When a key is highlighted, use the selector knob, F1 or Enter to confirm a key entry.

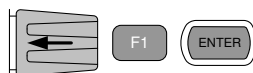

17. Use F2 (Back Space) to delete any previous entries/mistakes.



18. Press F3 (Save) to save the directory name.



19. Press F5 (Previous menu) to continue to the previous menus



- Delete File Name 20. Use the Selector knob to highlight a file/directory.

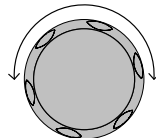

21. Press (F4) Delete.



22. To confirm deletion, press F4 again.

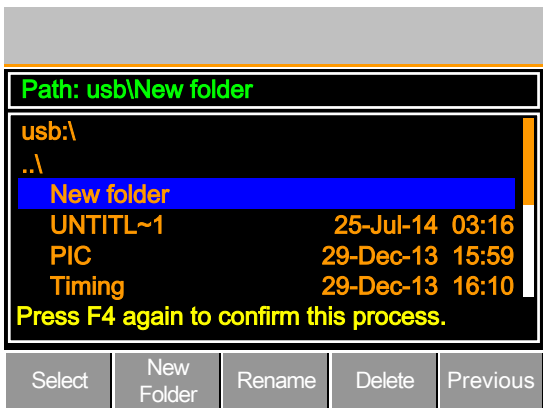

Saving Setups to USB Memory

Background Setup data contains all the channel data including Memory, Presets and Program Sequences.

There are four setups in internal memory. When saving to USB, all four setups will be saved. Conversely, when recalled, all four setups will be recalled to main memory.

The file extension *.S is used for Setup data only.

| | | |
|------------|-------------|------------|
| Parameters | Save File | 200X0_XX.S |
| | Update File | 200X0_XX.S |

- Panel operation**
1. Insert a USB flash drive into the front panel USB slot. 
 2. Ensure the USB path has been set. Page 243.

3. Press the File key.



4. Press F1 repeatedly until the Media USB menu appears.

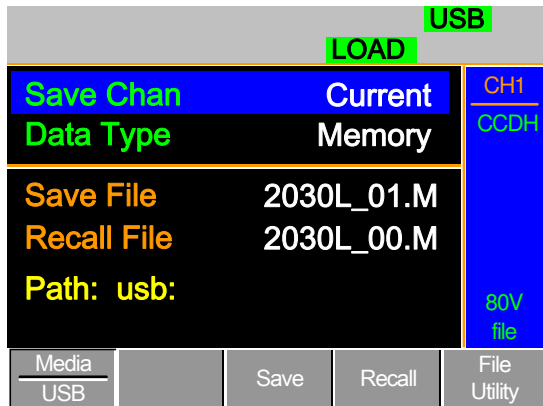
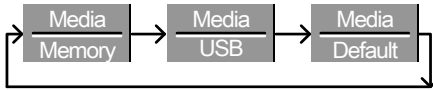

5. Use the Selector Knob to edit Save Chan and Data Type.
6. Choose All and Setup.

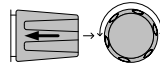

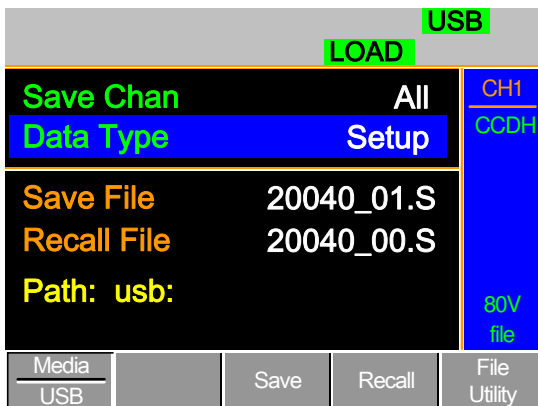

The screen will update to only show Setup files (*.S) that are available to save/recall in the default path directory.

Save/ Recall
Setups to USB

- Use the Selector Knob to edit Save File or Recall File. Rotating the selector knob will scroll through all the available setup files (*.S).

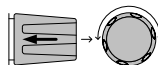

- Choose a file name (20XXX_XX.S).
- Press F3 (Save) to save the setup data or F4 (Recall) to recall the setup data.

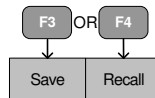

- A screen message will appear when the save/recall has completed.

20040_01.S Save Ok
20040_00.S Recall Ok



Note

Setups can only be saved if they have been saved to internal memory first. For details on how to save to internal memory see page 239.

Saving/Recalling Memory Data to USB

Background There are two options to save or recall Memory data to a USB flash drive:

Save Chan Current: Saves the active Channel's Memory data(M001~M120) into the default file path (20XXX_XX.M).

Save Chan All: Every channel's Memory data (CH1 M001~120 ~ CH8 M001~M120) will be saved into a directory (ALL00XX) as separate files for each channel (P0X0X_C1.M ~ P0X0X_C8.M).

Recall File: Recalls the selected file to the active channel's Memory (MXXX). It is not possible to update all the channels at once, only one channel at a time can be recalled.

The file extension *.M is used for Memory data only.

For more information about the file structures see, page 97.

| | |
|-------------------|--|
| Parameters | Save All Ch Directory ALL0000 ~ ALL0099 File: P0X0X_CX.M |
| | Save File File: 20XXX_XX.M |
| | Update File File: 20XXX_XX.M |

| | |
|------------------------|--|
| Panel operation | 1. Insert a USB flash drive into the front panel USB slot.  |
| | 2. Ensure the USB path has been set. Page 243. |

3. Press the File key.

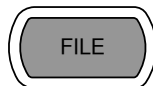

4. Press F1 repeatedly until the Media USB menu appears.

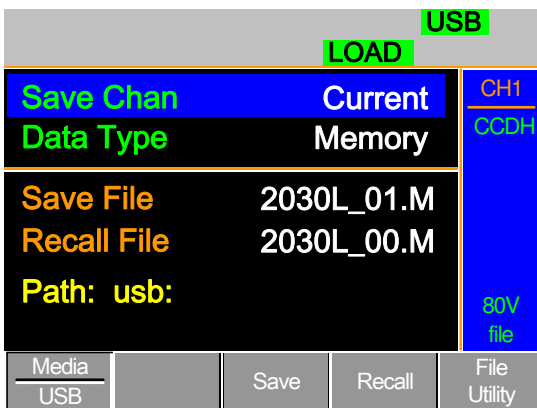
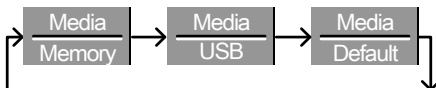

Save all Channels 5. Use the Selector knob to edit Save Chan and Data Type.

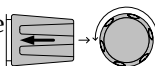

6. Choose All, and Memory



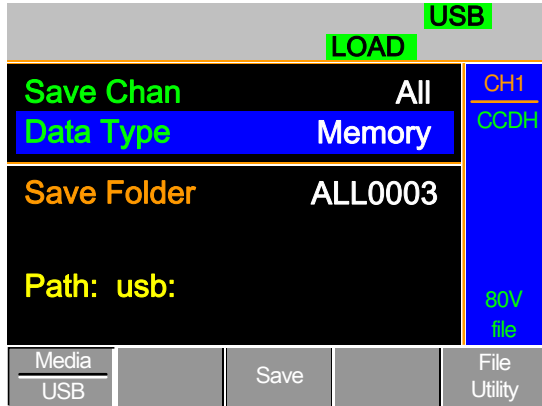

The screen updates to show Save Folder. Note it is not possible to recall all channels at once, only save.

7. Use the Selector Knob to edit Save Folder.

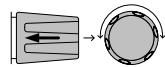

8. Choose a directory name (ALL0000~ALL0099).

Save Folder ALL0003



Note

Any used directories will not be available. It is not possible to over-write older directories. They must be deleted first.

9. Press F3 (Save)



10. A screen message will be displayed when complete.

ALL003 Save Ok

Save /Recall File

11. Use the Selector Knob to edit Save Chan and Data Type.

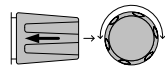

12. Choose Current and Memory.

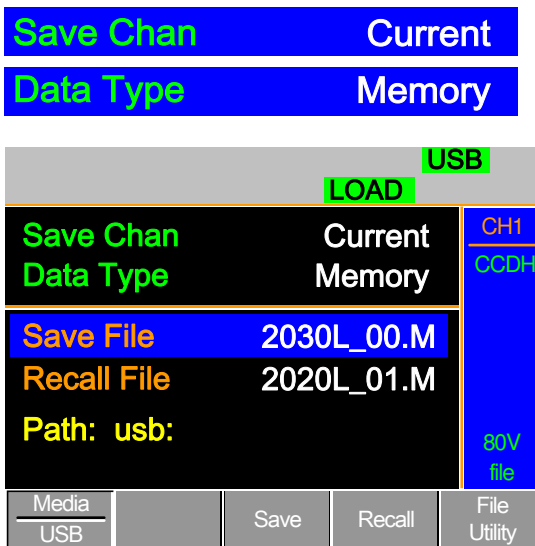

13. Use the selector knob to edit Save or Recall File.
14. Choose a file name.
15. Press F3(Save) to save or F4(Recall) to recall the current channel. (MXXX)
16. A save or recall message will be displayed when complete.

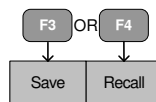

2030L_01.M Save Ok



Note

Remember only data that has been saved to internal memory will be saved to USB. Only the active channel will be saved.

If you try to recall data that originated from a different load module than the active channel, an error message will appear. The filename must reflect the active channel's load module type.

Machine Type Error

Saving/Recalling Presets to USB

Background There are two options to save or recall Channel Presets to a USB flash drive:

Save Chan Current: Saves the active Channel's Presets (P0~P9) into the default file path (20XXX_XX.P).



Save Chan All: Every channel's Presets (CH1 P0~P9 ~ CH8 P0~P9) will be saved into a directory (ALL00XX) as separate files for each channel (P0X0X_C1.P ~ P0X0X_C8.P)

Recall: Recalls the selected file to the active channel's Presets (P0~P9). It is not possible to update all the channels at once, only one channel at a time can be recalled.

The file extension *.P is used for channel Presets only.

For more information about the file structures see page 97.

| | |
|-----------|---|
| Parameter | Save All Ch Directory: ALL0000 ~ ALL0099 File: P0X0X_CX.P |
| | Save File File: 20XXX_XX.P |
| | Update File File: 20XXX_XX.P |

- Panel operation**
1. Insert a USB flash drive into the front panel USB slot.  
 2. Ensure the USB path has been set. Page 243.

3. Press the File key.

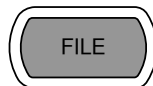

4. Press F1 repeatedly until the Media USB menu appears.

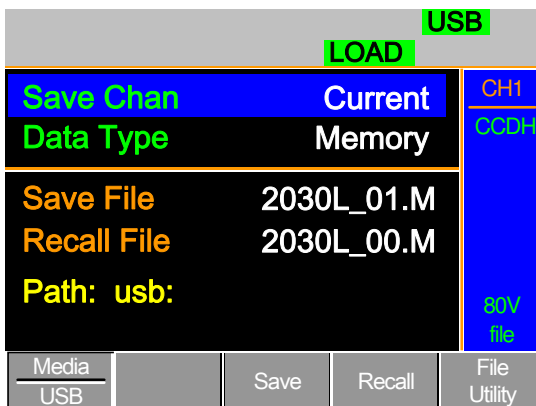
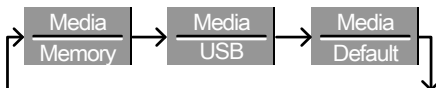

Save all Channel Presets

5. Use the Selector knob to edit Save Chan and Data Type.

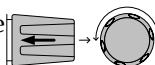

6. Choose All, and Preset



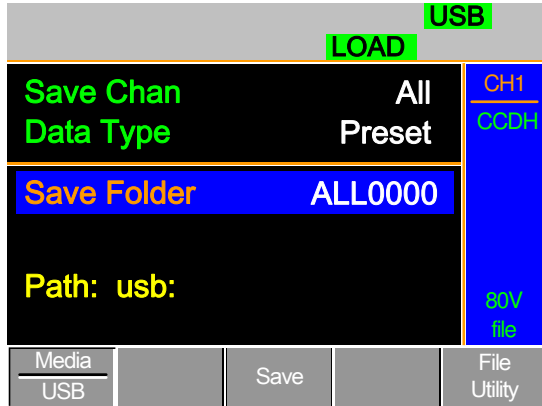

The screen updates to show Save Folder. Note it is not possible to recall all presets at once, only save.

7. Use the Selector Knob to edit Save Folder.

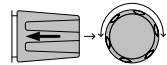

8. Choose a directory name (ALL0000~ALL0099).

Save Folder ALL0000



Note

Any used directories will not be available. It is not possible to over- write older directories. They must be deleted first.

9. Press F3 (Save)



10. A screen message will be displayed when the save is complete.

ALL0001 Save Ok

-
- Save/Recall Preset 11. Use the Selector Knob to edit (current channel) Save Chan and Data Type.

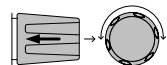

12. Choose Current and Preset.

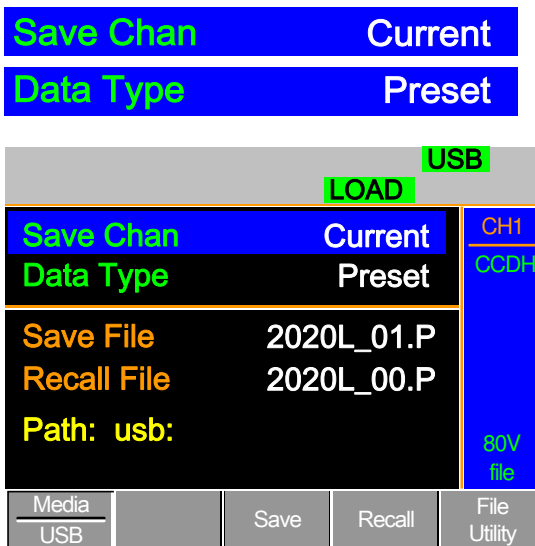

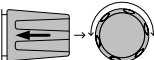
13. Use the selector knob to edit Save File or Recall file. 

14. Choose a file name.

15. Press F3 (Save) to save or F4 (Recall) to recall the Channel Presets. (PXX)

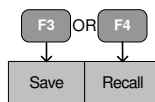

16. A message will be displayed when the save or recall has completed.

2020L_01.P Save Ok



Note

Remember only data that has been saved to internal memory will be saved to USB. Only the active channel presets will be saved.

If you try to recall data that originated from a different load module than the active channel, an error message will appear. The filename must reflect the active channel's load module type.

Saving/Recalling Sequences to USB

Background There are two options to save or recall Sequences to a USB flash drive. Sequences can either be saved from all channels or from the current channel only.

Save All: Every channels' sequences will be saved into a directory (ALL00XX) as separate files for each channel (20XXX_C1.A~ 20XXX_C8.A).



Save Current: The current channel's sequence will be saved into the default directory (20XXX_XX.A)

Recall: Sequences can only be recalled for the current channel. It is not possible to recall all channels' Sequences at once.

The file extension *.A is used for Sequences only.

For more information about the file structures see page 97.

| | |
|-------------------|--|
| Parameters | Save All SEQ Directory: ALL0000 ~ ALL0099 File: 20XXX_C1.A |
| | Save Current SEQ File: 20XXX_XX.A |
| | Recall Current SEQ File: 20XXX_XX.A |

- Panel operation**
1. Insert a USB flash drive into the front panel USB slot.  
 2. Ensure the USB path has been set. Page 243.
 3. Press the File key. 

4. Press F1 repeatedly until the Media USB menu appears.

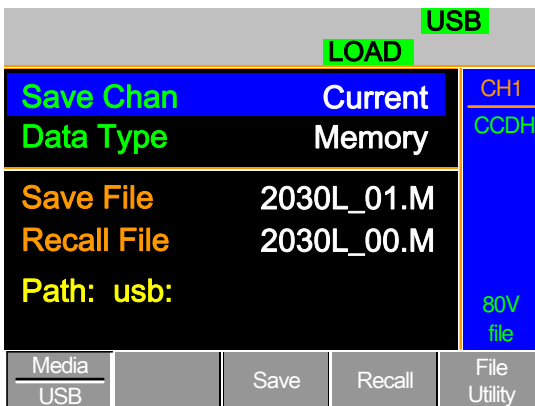
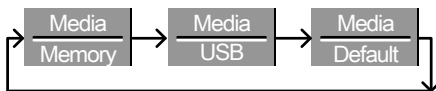

Save all Channel
SEQ

5. Use the Selector knob to edit Save Chan and Data Type.
6. Choose All, and SEQ

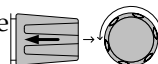

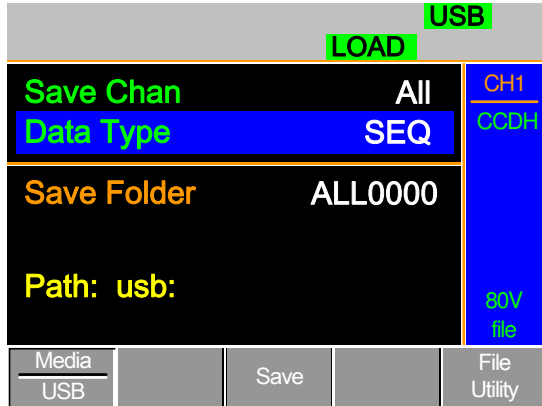

The screen updates to show Save Folder. Note it is not possible to recall all SEQ data at once, only save.

7. Use the Selector Knob to edit Save Folder.

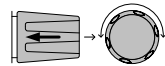

8. Choose a directory name (ALL0000~ALL0099).

Save Folder ALL0000



Note

Any used directories will not be available. It is not possible to over-write older directories. They must be deleted first.

9. Press F3 (Save)



10. A screen message will be displayed when saving.

Save All Chan in ALL000

Save/Recall SEQ (current channel)

11. Use the Selector Knob to edit Save Chan and Data Type.

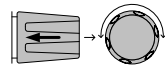

12. Choose Current and SEQ.

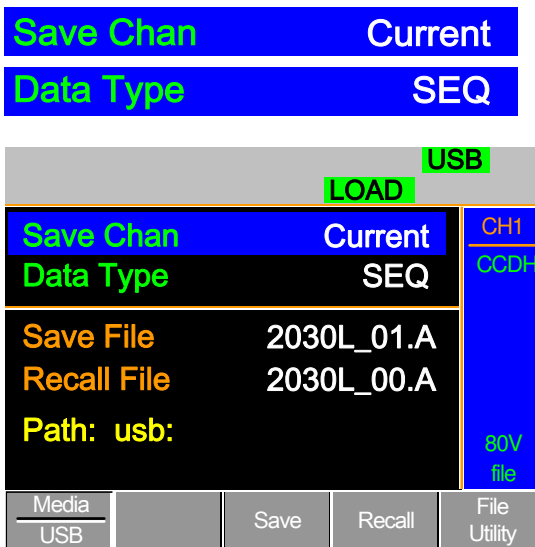

13. Use the selector knob to edit Save File or Recall File.
14. Choose a file name.
15. Press F3 (Save) to save or F4 (Recall) to recall the current channel's sequence.
16. A message will be displayed when the file is saved/recalled.

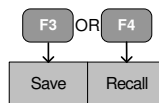

Save in 2030L_01.A



Note

Remember a sequence must first be saved to (internal) memory before it can be saved to USB.

If you try to recall data that originated from a different load module than the active channel, an error message will appear. The filename must reflect the active channel's load module type.

Quick Preset Recall/Save

Background The PEL-2000A series mainframes have up to 10 Channel Presets (P0~P9). Quick recalling or saving presets will only be applicable to the active channel. For example, P1 on CH1 is not the same as P1 on CH2.

Parameter Presets P0 ~ P9 (current channel)

Panel Operation 1. Remove any USB devices from the front panel.

2. Select the channel you want to save Channel Presets to. Page 130.

Save Current Channel Preset 3. To save a Channel Preset, press the Preset key and hold one of the number keys (0-9) for a short time until a beep is heard.

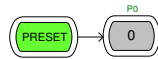

0 = P0
1 = P1 etc.

Save All Channel Presets 4. To save All Channel Presets, press the Shift key, the Preset key and hold one of the number keys (0-9) for a short time until a beep is heard.

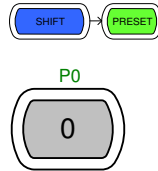

0 = P0
1 = P1 etc.

5. Press the Preset key again to deactivate it.

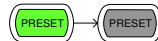

The Preset will be saved to the one of 10 presets depending on the number pressed.

Recall Current Channel Preset

6. Press the Preset key and one of the number keys.

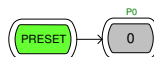

0 = P0
1 = P0 etc.

Recall All Channel Presets

7. Press the Shift key, the Preset key and one of the number keys.

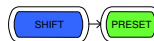

0 = P0
1 = P0 etc.

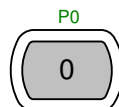

8. Press the Preset key again to deactivate it.

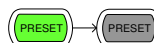

Only the active channel's Channel preset will be recalled.

Recall Setup Memory (Frame link).

Background

A master mainframe can command all mainframes (master and slave) to recall setup memory from their internal memory. No setup data will be recalled from the master mainframe to the slave units.

Parameter

Setup memory 1~4.

Panel Operation

1. On the Master mainframe, follow the procedure for recalling setup memory for all channels.

Page 241

All mainframes will update setup memory upon recall

Recall Preset Memory (Frame link)

Background A master mainframe can command all units to recall preset memory from their internal memory. Only the first three preset memories (P0~P2) can be recalled.

Channel presets can be recalled via the file menu or using the quick recall feature using the number pad.

Parameters Presets P0 ~ P2 (current channel)

Panel Operation: Quick Keys 1. Remove any USB devices from the front panel.

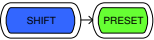
2. On the master mainframe, press the Shift and Preset key. 

3. Press one of the number keys (0-2).
 0 = P0
 1 = P1 etc

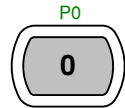

The screen will flash momentarily when the presets are recalled.

Panel Operation: File menu 4. On the master mainframe follow the procedure to recall preset memory for all channels. Page 239

The screen will flash momentarily when the presets are recalled.

Recall Factory Defaults

Background The Factory defaults can be recalled at any time. For details on the factory defaults please see the default settings in the appendix, page 285

Panel Operation 1. Press the File key.

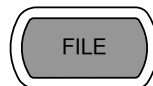

2. Press F1 repeatedly until the Media Default menu appears.

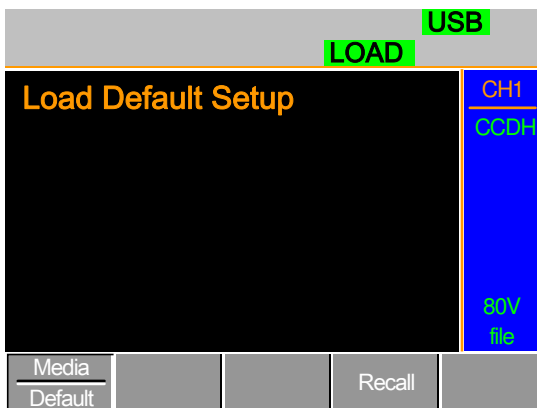

3. Press Recall (F4) to recall the factory default settings.



4. Wait a short time for the settings to be recalled.

I NTERFACE

The Interface chapter details the pin configuration of the RS232, GPIB, Frame Link, Channel Control and Go/NoGo interfaces.

| | |
|--|------------|
| Interface Configuration | 268 |
| Configure RS-232C interface | 268 |
| Configure GPIB interface | 269 |
| Configure Channel Control interface .. | 270 |
| Configure Frame Link Interface | 271 |
| Configure Go/NoGo Interface | 274 |
| USB Interface Connection | 275 |

Interface Configuration

Configure RS-232C interface

| | | |
|-----------------------|-----------|------------|
| RS-232C configuration | Connector | DB-9, Male |
| | Baud rate | 9600 |
| | Parity | None |
| | Data bit | 8 |
| | Stop bit | 1 |

Connect the RS-232C cable (GW Instek part no. GTL-232) to the rear panel port: DB-9 male connector.

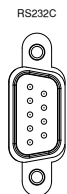

Pin assignment

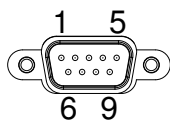

- 2: RxD (Receive data)
- 3: TxD (Transmit data)
- 5: GND
- 1, 4, 6, 7, 8, 9: No connection

PC connection

Use the Null Modem connection as shown in the diagram below.

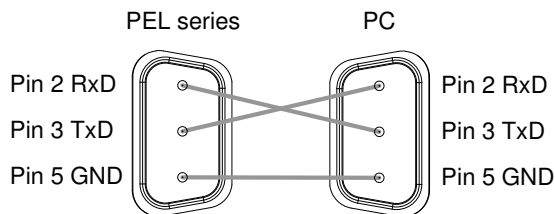

Configure GPIB interface

Connection

Connect the GPIB cable to the rear panel port: 24-pin female connector.



Pin assignment

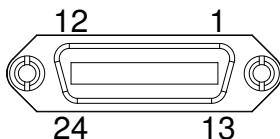

| | | | |
|-------|-----------------|-------|---------------|
| Pin1 | Data line 1 | Pin13 | Data line 5 |
| Pin2 | Data line 2 | Pin14 | Data line 6 |
| Pin3 | Data line 3 | Pin15 | Data line 7 |
| Pin4 | Data line 4 | Pin16 | Data line 8 |
| Pin5 | EOI | Pin17 | REN |
| Pin6 | DAV | Pin18 | Ground |
| Pin7 | NRFD | Pin19 | Ground |
| Pin8 | NDAC | Pin20 | Ground |
| Pin9 | IFC | Pin21 | Ground |
| Pin10 | SRQ | Pin22 | Ground |
| Pin11 | ATN | Pin23 | Ground |
| Pin12 | Shield (screen) | Pin24 | Signal ground |

GPIB constraints

- Maximum 15 devices altogether, 20m cable length, 2m between each device
- At least 2/3 of the devices turned On
- No loop or parallel connection

Configure Channel Control interface

| | | |
|-------------------------------|-----------------|-----------------------------------|
| Channel control configuration | Connector | Screwless connector. |
| | Wire Gauge | 22-28 AWG (24 AWG recommended). |
| | Wire connection | 10 mm strip gauge for connection. |

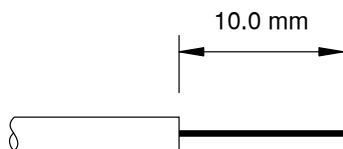

Input 0-10V.

Pin Assignment



| | | |
|---|-------------------------|---|
| 1 | GND | Negative potential of the load input terminal. |
| 2 | I MON (OUTPUT) | Load input current monitor; where 0V = 0% of input current and 10V = 100% of input current. |
| 3 | V MON (OUTPUT) | Load input voltage monitor; where 0V = 0% of input voltage and 10V = 100% of input voltage. |
| 4 | Ext Voltage ref (INPUT) | External voltage reference; Where 0V=0% of rating voltage/current and 10V = 100% of rating voltage/current. The external voltage reference is for CC and CV mode. |

| | |
|---------------------------------------|--|
| 5 Load On | Load On Input. Load on = Active low, 0-1V Load off = Active high, 4-5V. (Using the + load polarity in conjunction with a 10kΩ pull up resistor) |
| 6 +15V | Internal power output. Max 50mA. |
| Channel Control Interface Constraints | Mode/Range Mode and Range configuration is only selected via the front panel. |

Configure Frame Link Interface

| | | |
|------------|--|---|
| Connection | Connect the Frame link cable (MIL 20 pin connector) to the rear panel port: 20-pin male connector. |  |
|------------|--|---|

Pin assignment
(Frame link connector 1)

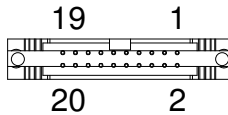

| | | |
|------|----------|--|
| Pin1 | A | Recall Preset memory 0 (All channels) |
| Pin2 | B | Recall Preset memory 1 (All channels) |
| Pin3 | C | Recall Preset memory 2 (All channels) |
| Pin4 | TRIG_OUT | Trigger out |
| Pin5 | MEM_0 | Recall Setup memory 1 (All channels) |
| Pin6 | MEM_1 | Recall Setup memory 2 (All channels) |

| | | |
|-------|--------------|--|
| Pin7 | MEM_2 | Recall Setup memory 3 (All channels) |
| Pin8 | MEM_3 | Recall Setup memory 4 (All channels) |
| Pin9 | Enable | Enable Load (On/Off), recall Preset memory (0- 3) and Setup memory (1- 4) |
| Pin10 | Load On/Off | |
| Pin11 | Not used | |
| Pin12 | Not used | |
| Pin13 | Not used | |
| Pin14 | Not used | |
| Pin15 | Load Status | Output, load on status. |
| Pin16 | Alarm Status | Output alarm activated. |
| Pin17 | +5V | Output, 5V+, 100mA. |
| Pin18 | N.C | No connection. |
| Pin19 | GND | Ground |
| Pin20 | GND | Ground |

Pin assignment
(Frame link
connector 2)

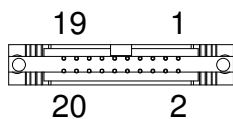

| | | |
|------|---------|---|
| Pin1 | Sync._A | Sync signal, Recall Preset memory 0 (All channels) |
| Pin2 | Sync._B | Sync signal, Recall Preset memory 1 (All channels) |
| Pin3 | Sync._C | Sync signal, Recall Preset memory 2 (All channels) |
| Pin4 | TRIG_IN | Reserved |

| | | |
|-------|----------------------|--|
| Pin5 | Sync._MEM_0 | Sync signal, Recall Setup memory 1 (All channels) |
| Pin6 | Sync._MEM_1 | Sync signal, Recall Setup memory 2 (All channels) |
| Pin7 | Sync._MEM_2 | Sync signal, Recall Setup memory 3 (All channels) |
| Pin8 | Sync._MEM_3 | Sync signal, Recall Setup memory 4 (All channels) |
| Pin9 | Sync._Enable | Sync signal, Enable Load (On/Off), recall Preset memory (0-3) and Setup memory (1-4) |
| Pin10 | Sync._Load On/Off | Sync signal, Load On/Off |
| Pin11 | Not used | |
| Pin12 | Not used | |
| Pin13 | Not used | |
| Pin14 | Not used | |
| Pin15 | Load Status | Sync signal, Output, load on status. |
| Pin16 | Alarm Status | Sync signal, Output alarm activated. |
| Pin17 | N.C | No connection |
| Pin18 | +5V | +5V, 100mA |
| Pin19 | GND | Ground |
| Pin20 | GND | Ground |

- | | |
|------------------------|---|
| Connection | <ul style="list-style-type: none"> • Input: active low (0-1V), active high (4-5V) • Inputs (5V, 10kΩ pull-up resistor) • Open collector outputs (Load status, Alarm Status, +5V) maximum 30VDC with 1.1V saturation voltage (100mA). • When enable is on (active low), the following is disabled from the mainframe: activating loads and recalling preset or setup memory. |
| Frame Link constraints | <ul style="list-style-type: none"> • Maximum 5 (1 master + 4 slave units) devices can be linked altogether with a maximum cable length of 30cm for each cable. • All the connected devices must be turned on. • No loop or parallel connections |

Configure Go/NoGo Interface

Connection Use a DSUB (DB-15 Female) connector to connect to the Go/NoGo port.

The Go/NoGo port is an output only port.

GO / NG OUTPUT

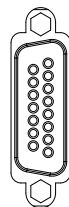

Pin assignment

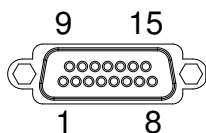

| | | | |
|------|-----------|-------|-----------|
| Pin1 | Ch1_GO/NG | Pin9 | Ch5_GO/NG |
| Pin2 | GND | Pin10 | GND |
| Pin3 | Ch2_GO/NG | Pin11 | Ch6_GO/NG |
| Pin4 | GND | Pin12 | GND |

| | | | |
|------|--------------|-------|-----------|
| Pin5 | Ch3_GO/NG | Pin13 | Ch7_GO/NG |
| Pin6 | GND | Pin14 | GND |
| Pin7 | Ch4_GO/NG | Pin15 | Ch8_GO/NG |
| Pin8 | GO/NG_Enable | | |

Connection Type Open collector output maximum 30VDC with 1.1V saturation voltage (100mA).

| | |
|----------------|--------------------------------|
| 30 V DC (high) | Pass (Go) or SPEC Test: OFF |
| 1.1 V DC (low) | Fail (NoGo) |

USB Interface Connection

Connection For USB remote connection, use the USB-B port on the mainframe rear panel.



FAQ

Q1. The load voltage indicated on the load module is below expected.

A1. Ensure the load leads are as short as possible, twisted and use the appropriate wire gauge. Ensure that voltage sense is used, this can help alleviate the voltage drop across the load the leads.

Q2. When I try to start a program sequence, it will not run. “No Active Channel” is displayed.

A2. Ensure the channel(s) is activated (not set to OFF) in the FUNC→Program→Active Channel menu.

Q3. When trying to save to USB, the USB memory stick is unresponsive.

A3. Try restarting the PEL mainframe. If this fails to solve the problem, ensure the USB memory is cleanly formatted.

Q4. When I try to clear an alarm, it doesn't work.

A4. Before clearing an alarm or using the Protection Clear All function, the load must be turned off. After the load is off, the alarm(s) can be cleared.

For more information, contact your local dealer or GW Instek at www.gwinstek.com / marketing@goodwill.com.tw.

A PPENDIX

Fuse Replacement

- Step
1. Turn off the power at the wall socket and rear panel. Remove the power cord.
 2. Remove the fuse socket using a minus driver.

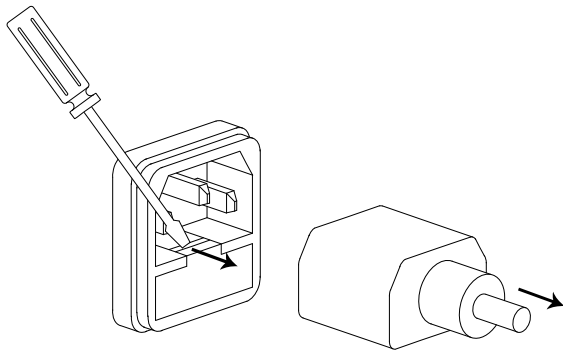

3. Replace the fuse in the holder.

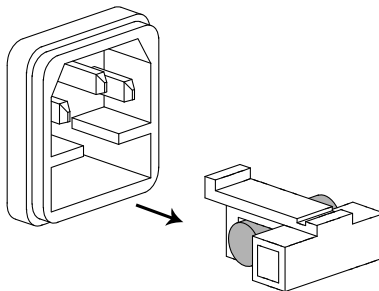

Rating T3.15A, 250V

Firmware Update

Background The PEL-2000A firmware can be easily updated using a USB memory stick. For the latest firmware please see your local GW Instek distributor or download the latest firmware from www.gwinstek.com.

File Name File: P2KAXXXX.UPG



Note

Copy the firmware file (*.UPG) into the root directory of a USB stick before proceeding with the firmware update.

Panel operation

1. Insert a USB flash drive into the front panel USB slot.

2. Press the File key.



3. Press F1 repeatedly until the Media USB menu appears.

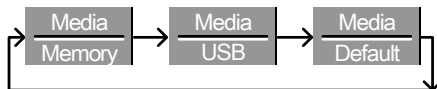

4. Press F5 (File Utility).



5. Use the selector knob to scroll down to the firmware file (*.UPG) and press the selector knob, Enter or F1.

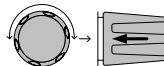

6. Press F1 to confirm the firmware upgrade.



7. Wait for the firmware upgrade to finish, a message will be displayed upon completion.

8. Turn the power Off and On from the front panel to reset the load generator.



Do not turn the load generator off or remove the USB memory when the firmware is being read or upgraded.

Calibration

Background

The PEL-2000A load generator should be calibrated at least on a yearly basis.

GW Instek does not support End-User calibration. Please see your distributor for calibration details.

Range Chart

PEL-2020A

Low Range

10W

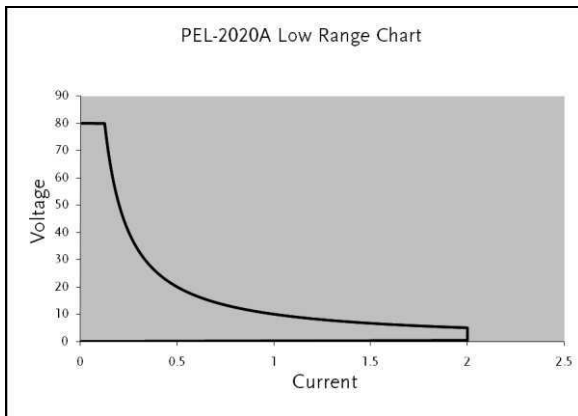

PEL-2020A

High Range

100W

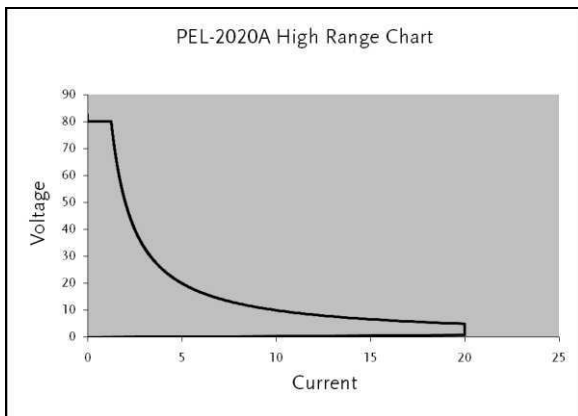

PEL-2030A

Left Channel

30W

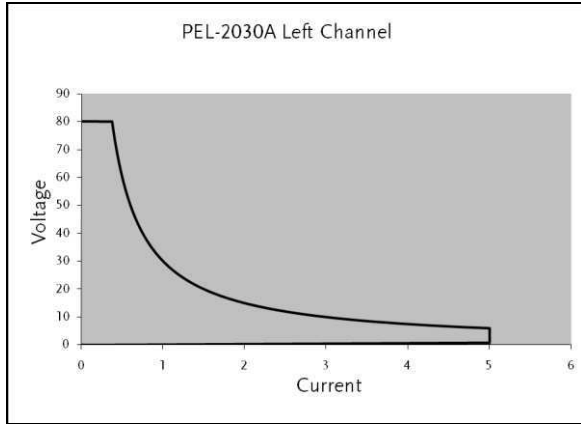

PEL-2030A

Right Channel

Low Range

25W

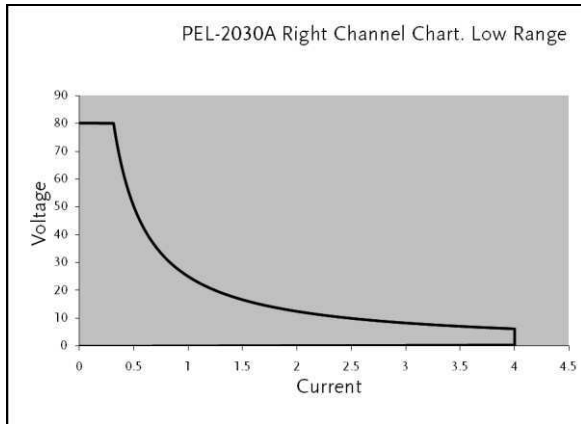

PEL-2030A

Right Channel

High Range

250W

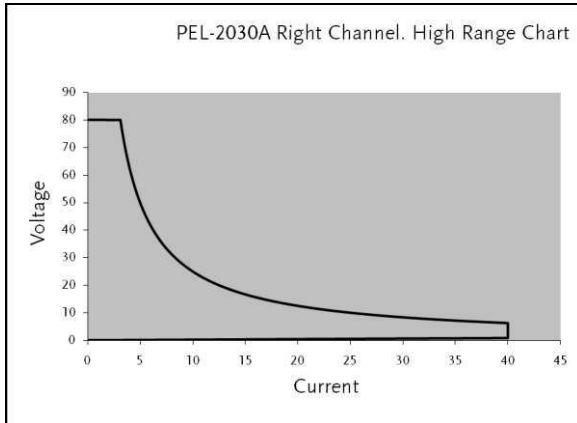

PEL-2040A

Low Range

35W

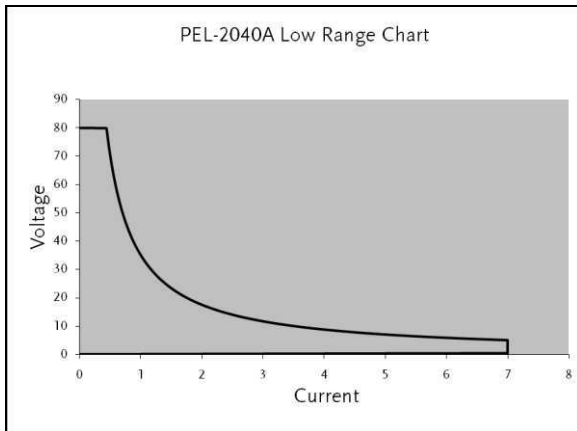

PEL-2040A

High Range

350W

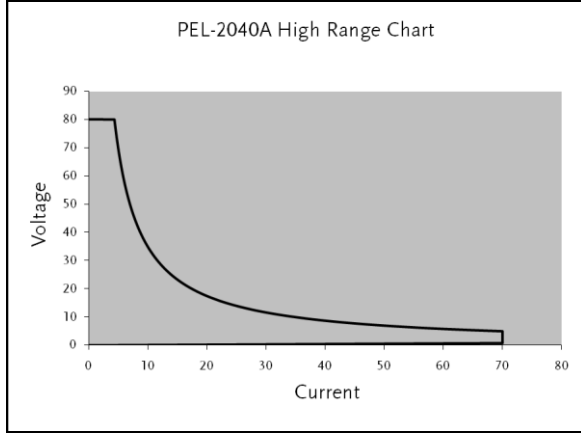

PEL-2041A

Low Range

35W

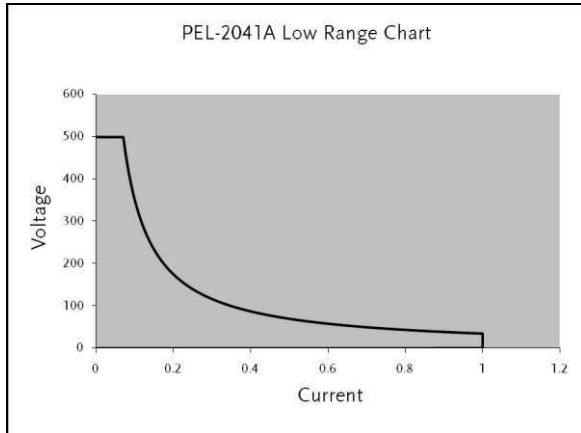

PEL-2041A

High Range

350W

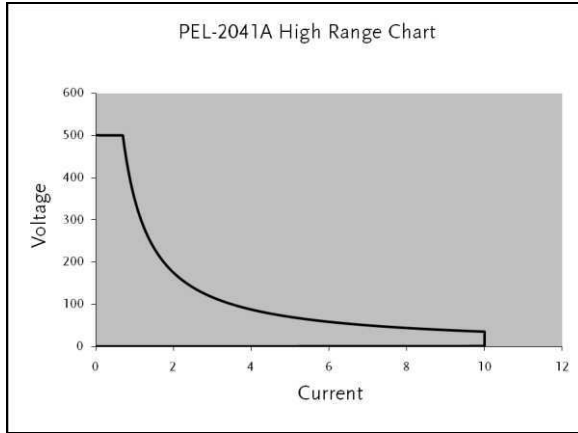

Default Settings

| Menu Item | | |
|---------------------|-----------------------|---------------------------------|
| CC Mode | Mode: Static | A/B Value: Min A |
| | Rising Slew Rate: Max | Falling Slew Rate: Max |
| CR Mode | Mode: Static | A Value: Max Ω |
| | Rising Slew Rate: Max | Falling Slew Rate: Max |
| CV Mode | Response: Slow | A Value: Max V |
| | Curr Limit: Max A | |
| CP Mode | Range: High | A/B Value: Min A |
| | Curr Limit: Max A | |
| Chan- Protection | OCP Level: Max | OCP Setting: OFF |
| | OVP Level: Max | OVP Setting: OFF |
| | OPP Level: Max | OPP Setting: OFF |
| | UVP Level: Off | UVP Setting: Clear |
| | Protection Clear: All | |
| Chan- Other | CC Vrange: High | Von Voltage: 0V |
| | Von Latch: Off | Short Key: Toggle |
| | CH CONT: OFF | Independent: OFF |
| | Load D-Time: 0.0s | CCH Step: Min |
| | CRH Step: Min | CRL Step: Min |
| | CV Step: Min | Response: Normal |
| Chan-Parallel | Parallel Unit: OFF | Parallel Mode: Para |
| | Display Mode: V,I | |
| Chan- Seq. Edit | A Value: 0 | Rising/Falling SlewRate: Max |
| | Duration Time: 0.001s | |

| | | |
|---------------------------|-----------------------------|-------------------------|
| Chan- Seq. Edit - Loop | Repeat: Infinity Times | Start of Loop: 001 Step |
| | On End Of Seq.: OFF | CC Vrange: High |
| Chan- Go/NoGo | Spec Test: Off | Entry Mode: Value |
| | High: Max | Low: Min |
| FUNC- Program | PROG: 01 | SEQ: 01 |
| | Memory: 001 | Run: Skip |
| | On-Time: 0.1s | Off-Time: Off |
| | P/F-Time: Off | On-Time: 0.1s |
| | Short Channel: All channels | |
| FUNC- Chain | Start: 01 | P01~P12→: Off |
| FUNC- Run | CH 01~08: Active Off | |
| FUNC- Sequence | CH01~08: Time Setting Off | SEQ: Off |
| Utility- Load | Auto Load: Off | Auto Load On: Prog |
| Utility- Interface | USB | |
| Utility- Other | Speaker: Off | Contrast: 8 |
| | Brightness: 70 | Frame CONT: NA |
| | Alarm (M): On | Alarm (S): Off |
| | Knob Type: Updated | Go_NoGo Tone: Off |
| | Slave Knob: SetValue | Language: English |

Specifications

| | PEL-2002A | PEL-2004A |
|------------------------------|--|-----------|
| MODULE SLOTS | 2 | 4 |
| GENERAL | | |
| Operating Environment | | |
| Temperature | 0°C to 40°C | |
| Altitude | Up to 2000m | |
| Location | Indoor, no direct sunlight, dust free, almost non conductive pollution. | |
| Storage Environment | | |
| Temperature | -10°C to 70°C | |
| Relative Humidity | < 80% | |
| Location | Indoor | |
| Power Supply | AC 115V±15%/230V±15% switchable, 50/60Hz, Transient overvoltage on the main supply is 2500V. | |
| Fuse | T3.15A/250V | |
| Pollution degree | 2 | |
| Measurement | 1 | |
| Category | | |
| Rear panel USB class | USB 2.0 full speed (CDC-ACM) | |

| PEL-2020A (100Wx2) | | |
|---------------------------------|--------------------------|----------------------------|
| RANGE | Low | High |
| CURRENT | 0~2A | 0~20A |
| VOLTAGE | 1~80V | |
| MIN.OPERATING VOLTAGE (dc)Typ.) | 0.4V at 2A 0.2V at 1A | 0.8V at 20A 0.4V at 10A |

STATIC MODE

CONSTANT CURRENT MODE

| | | |
|-----------------|-----------------------------|-----------------------------|
| Operating Range | 0~2A | 0~20A |
| Setting Range | 0~2.04A | 0~20.4A |
| Resolution | 0.1mA | 1mA |
| Accuracy | $\pm(0.1\%set + 0.1\%F.S.)$ | $\pm(0.1\%set + 0.2\%F.S.)$ |

CONSTANT RESISTANCE MODE

| | |
|-----------------|--|
| Operating Range | 0.075Ω~300Ω(100W/16V) 3.75Ω~15kΩ(100W/80V) |
| Setting Range | 0.075Ω~300Ω(100W/16V) 3.75Ω~15kΩ(100W/80V) |
| Resolution | 0.333mS(100W/16V) 6.667uS(100W/80V) |
| Accuracy | 300Ω : $\pm(0.2\%set + 0.1S)$ 15kΩ: $\pm(0.1\%set + 0.01S)$ |

CONSTANT VOLTAGE + CONSTANT CURRENT MODE

| | |
|-----------------------|----------------------------------|
| Operating Range | 1~80V |
| Setting Range | 0~81.6V |
| Resolution | 2mV |
| Accuracy | $\pm(0.05\%set + 0.1\%F.S.)$ |
| Current Setting Range | 0~20A |
| Resolution | 1mA |
| Accuracy | $\pm(0.1\%set + 0.2\%F.S.^{*1})$ |

NOTE : *1: F.S. = Full scale of H Range

CONSTANT POWER MODE

| | | |
|-----------------|----------------------------------|-----------------------------|
| Operating Range | 1~10W | 1~100W |
| Setting Range | 0~10.2W | 0~102W |
| Resolution | 1mW | 10mW |
| Accuracy | $\pm(0.5\%set + 0.5\%F.S.^{*1})$ | $\pm(0.5\%set + 0.5\%F.S.)$ |

NOTE : *1: F.S. = Full scale of H Range

DYNAMIC MODE

| | | |
|----------|--|--|
| T1&T2 | 0.025ms ~ 10ms / Res: 1us 10ms ~ 30s / Res: 1ms | |
| Accuracy | 1us / 1ms \pm 100ppm | |

CONSTANT CURRENT MODE

| | | |
|-------------------|---------------------------|---------------------------|
| Slew Rate | 0.32 ~ 80mA/us | 3.2 ~ 800mA/us |
| Slew Rate | 0.32mA/us | 3.2mA/us |
| Resolution | | |
| Slew Rate Setting | $\pm(10\% + 15\text{us})$ | $\pm(10\% + 15\text{us})$ |
| Accuracy | | |
| Current | 0~2A | 0~20A |
| Current | 0.1mA | 1mA |
| Resolution | | |
| Current Accuracy | $\pm 0.4\%$ F.S. | |

CONSTANT RESISTANCE MODE

| | | |
|-------------------|--|---------------------------|
| Slew Rate | 0.32 ~ 80mA/us | 3.2 ~ 800mA/us |
| Slew Rate | 0.32mA/us | 3.2mA/us |
| Resolution | | |
| Slew Rate Setting | $\pm(10\% + 15\text{us})$ | $\pm(10\% + 15\text{us})$ |
| Accuracy | | |
| Resistance | 0.075 Ω ~300 Ω (100W/16V) | |
| Setting Range | 3.75 Ω ~15k(100W/80V) | |
| Resistance | 0.333mS(100W/16V) | |
| Resolution | 6.667 μ S(100W/80V) | |
| Resistance | 300 Ω : $\pm(0.5\%\text{set} + 0.1\text{S})$ | |
| Accuracy | 15k Ω : $\pm(0.5\%\text{set} + 0.01\text{S})$ | |

MEASUREMENT

VOLTAGE READBACK

| | | |
|------------|---|-------|
| Range | 0~16V | 0~80V |
| Resolution | 0.32mV | 1.6mV |
| Accuracy | $\pm(0.025\%\text{set} + 0.025\%$ F.S.) | |

CURRENT READBACK

| | | |
|------------|---------------------------------------|-------|
| Range | 0~2A | 0~20A |
| Resolution | 0.04mA | 0.4mA |
| Accuracy | $\pm(0.05\%\text{set} + 0.05\%$ F.S.) | |

POWER READBACK

| | | |
|----------|---------------------------------------|--------|
| Range | 0~10W | 0~100W |
| Accuracy | $\pm(0.1\%\text{set} + 0.1\%$ F.S.*1) | |

NOTE : *1 : Power F.S. = Vrange F.S. x Irange F.S.

PROTECTIVE

Over Power Protection

| | |
|------------|-------------------------------------|
| Range | 1~102W |
| Resolution | 0.5W |
| Accuracy | $\pm(2\%set + 0.25\% \text{ F.S.})$ |

Over Current Protection

| | |
|------------|-------------------------------------|
| Range | 0~20.4A |
| Resolution | 0.05A |
| Accuracy | $\pm(2\%set + 0.25\% \text{ F.S.})$ |

Over Voltage Protection

| | |
|------------|-------------------------------------|
| Range | 1~81.6V |
| Resolution | 0.2V |
| Accuracy | $\pm(2\%set + 0.25\% \text{ F.S.})$ |

Over $\cong 85^{\circ}\text{C}$

Temperature

Protection

Rated Power Protection :

| | |
|----------|--------------|
| Value | 110W |
| Accuracy | $\pm 2\%set$ |

GENERAL

SHORT CIRCUIT

| | | |
|----------------|-----------------------|-----------------------|
| Current(CC) | $\cong 2.2/2\text{A}$ | $\cong 22/20\text{A}$ |
| Voltage(CV) | 0V | 0V |
| Resistance(CR) | $\cong 3.75\Omega$ | $\cong 0.075\Omega$ |

INPUT $500\text{k}\Omega$ (Typical)

RESISTANCE

(LOAD OFF)

| PEL-2030A (30W/250W) | | | |
|----------------------|--------------|------------|-------------|
| RANGE | Low | Low | High |
| CURRENT | 0~5A | 0~4A | 0~40A |
| VOLTAGE | 1~80V | | |
| MIN.OPERATING | 0.8V at 5A | 0.4V at 4A | 0.8V at 40A |
| VOLTAGE(dc) | 0.4V at 2.5A | 0.2V at 2A | 0.4V at 20A |

STATIC MODE

CONSTANT CURRENT MODE

| | | | |
|-----------------|---|---|---|
| Operating Range | 0~5A | 0~4A | 0~40A |
| Setting Range | 0~5.1A | 0~4.08A | 0~40.8A |
| Resolution | 0.125mA | 0.1mA | 1mA |
| Accuracy | $\pm(0.1\% \text{set} + 0.1\% \text{F.S.})$ | $\pm(0.1\% \text{set} + 0.1\% \text{F.S.})$ | $\pm(0.1\% \text{set} + 0.2\% \text{F.S.})$ |

CONSTANT RESISTANCE MODE

| | | |
|-----------------|--|--|
| Operating Range | 0.3 Ω ~1.2k Ω (30W/16V) 15 Ω ~60k Ω (30W/80V) | 0.0375 Ω ~150 Ω (250W/16V) 1.875 Ω ~7.5k Ω (250W/80V) |
| Setting Range | 0.3 Ω ~1.2k Ω (30W/16V) 15 Ω ~60k Ω (30W/80V) | 0.0375 Ω ~150 Ω (250W/16V) 1.875 Ω ~7.5k Ω (250W/80V) |
| Resolution | 83.333 μ S (30W/16V) 1.666 μ S (30W/80V) | 0.666mS(250W/16V) 13.333 μ S(250W/80V) |
| Accuracy | 1.2k Ω : $\pm(0.2\% \text{set} + 0.1\text{S})$ 60k Ω : $\pm(0.1\% \text{set} + 0.01\text{S})$ | 150 Ω : $\pm(0.2\% \text{set} + 0.1\text{S})$ 7.5k Ω : $\pm(0.1\% \text{set} + 0.01\text{S})$ |

CONSTANT VOLTAGE + CONSTANT CURRENT MODE

| | | |
|-----------------------|--|--|
| Operating Range | 1~80V | 1~80V |
| Setting Range | 0~81.6V | 0~81.6V |
| Resolution | 2mV | 2mV |
| Accuracy | $\pm(0.05\% \text{set} + 0.1\% \text{F.S.})$ | $\pm(0.05\% \text{set} + 0.1\% \text{F.S.})$ |
| Current Setting Range | 0~5A | 0~40A |
| Resolution | 0.125mA | 1mA |
| Accuracy | $\pm(0.1\% \text{set} + 0.2\% \text{F.S.})$ | $\pm(0.1\% \text{set} + 0.2\% \text{F.S.}^{*1})$ |

NOTE : *1 : F.S. = Full scale of H Range

CONSTANT POWER MODE

| | | | |
|-----------------|-----------------------|-------------------------|--------|
| Operating Range | 1~30W | 1~25W | 1~250W |
| Setting Range | 0~30.6W | 0~25.5W | 0~255W |
| Resolution | 1mV | 1mV | 10mV |
| Accuracy | ±(0.5%set + 0.5%F.S.) | ±(0.5%set + 0.5%F.S.*1) | |

NOTE : *1 : F.S. = Full scale of H Range

DYNAMIC MODE

| | | | |
|----------|--|--|--|
| T1&T2 | 0.025ms ~ 10ms / Res: 1us 10ms ~ 30s / Res: 1ms | | |
| Accuracy | 1us / 1ms + 100ppm | | |

CONSTANT CURRENT MODE

| | | | |
|-------------------|----------------|-----------------|-----------------|
| Slew Rate | 0.8 ~ 200mA/us | 0.64 ~ 160mA/us | 6.4 ~ 1600mA/us |
| Slew Rate | 0.8mA/us | 0.64mA/us | 6.4mA/us |
| Resolution | | | |
| Slew Rate setting | ±(10% + 15us) | ±(10% + 15us) | ±(10% + 15us) |
| Accuracy | | | |
| Current | 0~5A | 0~4A | 0~40A |
| Current | 0.125mA | 0.1mA | 1mA |
| Resolution | | | |
| Current Accuracy | ±0.4% F.S. | | |

CONSTANT RESISTANCE MODE

| | | | |
|-------------------|-------------------|---------------------------|-----------------|
| Slew Rate | 0.8 ~ 200mA/us | 0.64 ~ 160mA/us | 6.4 ~ 1600mA/us |
| Slew Rate | 0.8mA/us | 0.64mA/us | 6.4mA/us |
| Resolution | | | |
| Slew Rate Setting | ±(10% + 15us) | ±(10% + 15us) | ±(10% + 15us) |
| Accuracy | | | |
| Resistance | 0.3Ω~1.2kΩ | 0.0375Ω~150Ω(250W/16V) | |
| Setting Range | (30W/16V) | 1.875Ω~7.5kΩ(250W/80V) | |
| | 15Ω~60kΩ | | |
| | (30W/80V) | | |
| Resistance | 83.333uS | 0.666mS(250W/16V) | |
| Resolution | (30W/16V) | 13.333uS(250W/80V) | |
| | 1.666uS | | |
| | (30W/80V) | | |
| Resistance | 1.2kΩ: ±(0.5%set | 150Ω: ±(0.5%set + 0.1S) | |
| Accuracy | + 0.1S) | 7.5kΩ: ±(0.5%set + 0.01S) | |
| | 60kΩ: ±(0.5%set + | | |
| | 0.01S) | | |

MEASUREMENT

VOLTAGE READBACK

| | | | | |
|------------|----------------------------|-------|--------|-------|
| Range | 0~16V | 0~80V | 0~16V | 0~80V |
| Resolution | 0.32mV | 1.6mV | 0.32mV | 1.6mV |
| Accuracy | ±(0.025%set + 0.025% F.S.) | | | |

CURRENT READBACK

| | | | |
|------------|--------------------------|--------|-------|
| Range | 0~5A | 0~4A | 0~40A |
| Resolution | 0.1mA | 0.08mA | 0.8mA |
| Accuracy | ±(0.05%set + 0.05% F.S.) | | |

POWER READBACK

| | | | |
|------------|--------------------------|--------------------------|--------|
| Range | 0~30W | 0~25W | 0~250W |
| Resolution | ±(0.1%set + 0.1% F.S.*1) | ±(0.1%set + 0.1% F.S.*1) | |

NOTE : *1 : Power F.S. = Vrange F.S. x Irange F.S.

PROTECTIVE

Over Power Protection

| | | |
|------------|----------------------|----------------------|
| Range | 1~30.6W | 1~255W |
| Resolution | 0.15W | 1.25W |
| Accuracy | ±(2%set + 0.25%F.S.) | ±(2%set + 0.25%F.S.) |

Over Current Protection

| | | |
|------------|----------------------|----------------------|
| Range | 0~5.1A | 0~40.8A |
| Resolution | 0.0125A | 0.1A |
| Accuracy | ±(2%set + 0.25%F.S.) | ±(2%set + 0.25%F.S.) |

Over Voltage Protection

| | | |
|------------|----------------------|----------------------|
| Range | 1~81.6V | 1~81.6V |
| Resolution | 0.2V | 0.2V |
| Accuracy | ±(2%set + 0.25%F.S.) | ±(2%set + 0.25%F.S.) |

Over Temperature Protection ≒85°C

Rated Power Protection

| | | |
|----------|--------|--------|
| Value | 33W | 275W |
| Accuracy | ±2%set | ±2%set |

GENERAL

SHORT CIRCUIT

| | | | |
|-------------|---------|---------|---------|
| Current(CC) | ≒5.5/5A | ≒4.4/4A | ≒44/40A |
| Voltage(CV) | 0V | 0V | 0V |

| | | | | |
|-----------------------------------|--------------------|---------------------|-------------------------|------------------------|
| Resistance(CR) | $\approx 15\Omega$ | $\approx 0.3\Omega$ | $\approx 1.875\Omega$ | $\approx 0.0375\Omega$ |
| INPUT RESISTANCE (LOAD OFF) | | | 500k Ω (Typical) | |

| | PEL-2040A | | PEL-2041A | |
|------------------|--------------|-------------|--------------|-------------|
| RANGE | Low | High | Low | High |
| CURRENT | 0~7A | 0~70A | 0~1A | 0~10A |
| VOLTAGE | 0~80V | | 0~500V | |
| MIN.OPERATING | 0.4V at 7A | 0.8V at 70A | 0.4V at 1A | 0.8V at 10A |
| VOLTAGE(dc)Typ.) | 0.2V at 3.5A | 0.4V at 35A | 0.2V at 0.5A | 0.4V at 5A |

STATIC MODE

CONSTANT CURRENT MODE

| | | | | |
|-----------------|-----------------------------|-----------------------------|-----------------------------|-----------------------------|
| Operating Range | 0~7A | 0~70A | 0~1A | 0~10A |
| Setting Range | 0~7.14A | 0~71.4A | 0~1.02A | 0~10.2A |
| Resolution | 0.2mA | 2mA | 0.05mA | 0.5mA |
| Accuracy | $\pm(0.1\%set + 0.1\%F.S.)$ | $\pm(0.1\%set + 0.2\%F.S.)$ | $\pm(0.1\%set + 0.1\%F.S.)$ | $\pm(0.1\%set + 0.2\%F.S.)$ |

CONSTANT RESISTANCE MODE

| | | |
|-----------------|--|---|
| Operating Range | 0.025Ω~100Ω(350W/16V) 1.25Ω~5k(350W/80V) | 1.25Ω~5kΩ (350W/125V) 50Ω~200k(350W/500V) |
| Setting Range | 0.025Ω~100Ω(350W/16V) 1.25Ω~5k(350W/80V) | 1.25Ω~5kΩ(350W/125V) 50Ω~200k(350W/500V) |
| Resolution | 1mS(350W/16V) 20uS(350W/80V) | 20uS(350W/125V) 0.5uS(350W/500V) |
| Accuracy | 100Ω: $\pm(0.2\%set + 0.1S)$ 5kΩ: $\pm(0.1\%set + 0.01S)$ | 5kΩ: $\pm(0.2\%set + 0.02S)$ 200kΩ: $\pm(0.1\%set + 0.005S)$ |

CONSTANT VOLTAGE + CONSTANT CURRENT MODE

| | | |
|-----------------------|----------------------------------|----------------------------------|
| Operating Range | 1~80V | 2.5~500V |
| Setting Range | 0~81.6V | 0~510V |
| Resolution | 2mV | 10mV |
| Accuracy | $\pm(0.05\%set + 0.1\%F.S.)$ | $\pm(0.05\%set + 0.1\%F.S.)$ |
| Current Setting Range | 0~70A | 0~10A |
| Resolution | 2mA | 0.5mA |
| Accuracy | $\pm(0.1\%set + 0.2\%F.S.^{*1})$ | $\pm(0.1\%set + 0.2\%F.S.^{*1})$ |

NOTE : *1 : F.S. = Full scale of H Range

CONSTANT POWER MODE

| | | | | |
|-----------------|----------------------------------|----------------------------------|----------------------------------|----------------------------------|
| Operating Range | 1~35W | 1~350W | 1~35W | 1~350W |
| Setting Range | 0~35.7W | 0~357W | 0~35.7W | 0~357W |
| Resolution | 1mW | 10mW | 1mW | 10mW |
| Accuracy | $\pm(0.5\%set + 0.5\%F.S.^{*1})$ | $\pm(0.5\%set + 0.5\%F.S.^{*1})$ | $\pm(0.5\%set + 0.2\%F.S.^{*1})$ | $\pm(0.5\%set + 0.5\%F.S.^{*1})$ |

NOTE : *1 : F.S. = Full scale of H Range

DYNAMIC MODE

| | | |
|----------|--|--|
| T1&T2 | 0.025ms~10ms/Res: 1us 10ms ~ 30s / Res: 1ms | 0.025ms~10ms/Res: 1us 10ms ~ 30s / Res: 1ms |
| Accuracy | 1us / 1ms ± 100ppm | 1us / 1ms ± 100ppm |

CONSTANT CURRENT MODE

| | |
|----------------------------|--|
| Slew Rate | 0.001 ~ 0.01 ~ 0.16 ~ 1.6 ~ 0.28A/us 2.8A/us 40mA/us 400mA/us |
| Slew Rate | 0.001A/us 0.01A/us 0.16mA/us 1.6mA/us |
| Resolution | |
| Slew Rate Setting Accuracy | ±(10% + 15us) ±(10% + 15us) ±(10% + 15us) ±(10% + 15us) |
| Current | 0~7A 0~70A 0~1A 0~10A |
| Current Resolution | 0.2mA 2mA 0.05mA 0.5mA |
| Current Accuracy | ±0.4% F.S. ±0.4% F.S. |

CONSTANT RESISTANCE MODE

| | |
|----------------------------|--|
| Slew Rate | 0.001 ~ 0.01 ~ 0.16 ~ 1.6 ~ 0.28A/us 2.8A/us 40mA/us 400mA/us |
| Slew Rate | 0.001A/us 0.01A/us 0.16mA/us 1.6mA/us |
| Resolution | |
| Slew Rate Setting Accuracy | ±(10% + 15us) ±(10% + 15us) ±(10% + 15us) ±(10% + 15us) |
| Resistance Setting Range | 0.025Ω~100Ω(350W/16V) 1.25Ω~5kΩ(350W/125V) 1.25Ω~5k(350W/80V) 50Ω~200k(350W/500V) |
| Resistance Resolution | 1mS(350W/16V) 20uS(350W/125V) 20uS(350W/80V) 0.5uS(350W/500V) |
| Resistance Accuracy | 100Ω: ±(0.5%set + 0.1S) 5KΩ: ±(0.5%set + 0.02S) 5kΩ: ±(0.5%set + 0.01S) 200kΩ: ±(0.5%set + 0.005S) |

MEASUREMENT

VOLTAGE READBACK

| | |
|------------|---|
| Range | 0~16V 0~80V 0~125V 0~500V |
| Resolution | 0.32mV 1.6mV 2.5mV 10mV |
| Accuracy | ±(0.025%set + 0.025% F.S.) ±(0.025%set + 0.025% F.S.) |

CURRENT READBACK

| | |
|------------|---|
| Range | 0~7A 0~70A 0~1A 0~10A |
| Resolution | 0.14mA 1.4mA 0.02mA 0.2mA |
| Accuracy | ±(0.05%set + 0.05% F.S.) ±(0.05%set + 0.05% F.S.) |

POWER READBACK

| | | | | |
|----------|---|--------|---|--------|
| Range | 0~35W | 0~350W | 0~35W | 0~350W |
| Accuracy | $\pm(0.1\% \text{set} + 0.1\% \text{ F.S.}^{*1})$ | | $\pm(0.1\% \text{set} + 0.1\% \text{ F.S.}^{*1})$ | |

NOTE : *1 : Power F.S. = Vrange F.S. x Irange F.S.

PROTECTIVE

Over Power Protection

| | | |
|------------|--|--|
| Range | 1~357W | 1~357W |
| Resolution | 1.75W | 1.75W |
| Accuracy | $\pm(2\% \text{set} + 0.25\% \text{F.S.})$ | $\pm(2\% \text{set} + 0.25\% \text{F.S.})$ |

Over Current Protection

| | | |
|------------|--|--|
| Range | 0~71.4A | 0~10.2A |
| Resolution | 0.175A | 0.025A |
| Accuracy | $\pm(2\% \text{set} + 0.25\% \text{F.S.})$ | $\pm(2\% \text{set} + 0.25\% \text{F.S.})$ |

Over Voltage Protection

| | | |
|------------|--|--|
| Range | 1~81.6V | 1~510V |
| Resolution | 0.2V | 1.25V |
| Accuracy | $\pm(2\% \text{set} + 0.25\% \text{F.S.})$ | $\pm(2\% \text{set} + 0.25\% \text{F.S.})$ |

Over $\cong 85^{\circ}\text{C}$ $\cong 85^{\circ}\text{C}$

Temperature

Protection

Rated Power Protection:

| | | |
|----------|----------------------|----------------------|
| Value | 385W | 385W |
| Accuracy | $\pm 2\% \text{set}$ | $\pm 2\% \text{set}$ |

GENERAL

SHORT CIRCUIT

| | | | | |
|----------------|-----------------------|-----------------------|-----------------------|-----------------------|
| Current(CC) | $\cong 7.7/7\text{A}$ | $\cong 77/70\text{A}$ | $\cong 1.1/1\text{A}$ | $\cong 11/10\text{A}$ |
| Voltage(CV) | 0V | 0V | 0V | 0V |
| Resistance(CR) | $\cong 1.25\Omega$ | $\cong 0.025\Omega$ | $\cong 50\Omega$ | $\cong 1.25\Omega$ |

INPUT 500k Ω (Typical) 500k Ω (Typical)

RESISTANCE

(LOAD OFF)

Dimensions

PEL-2002A/PEL-2004A

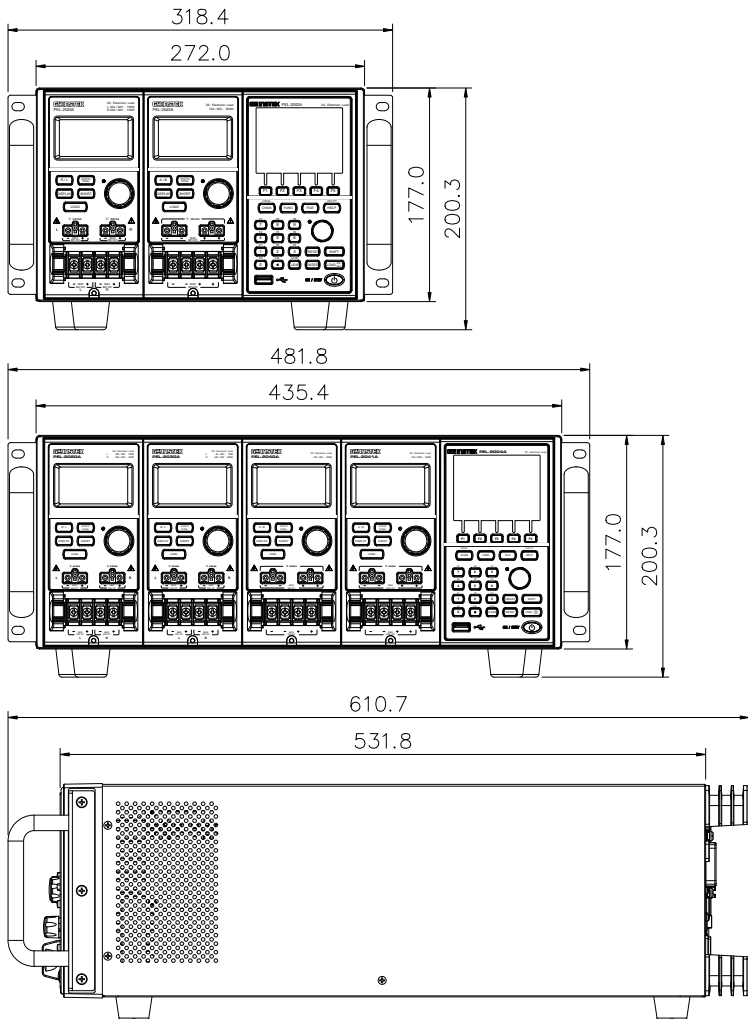

PEL-2020A/PEL-2030A/PEL-2040A/PEL2041A

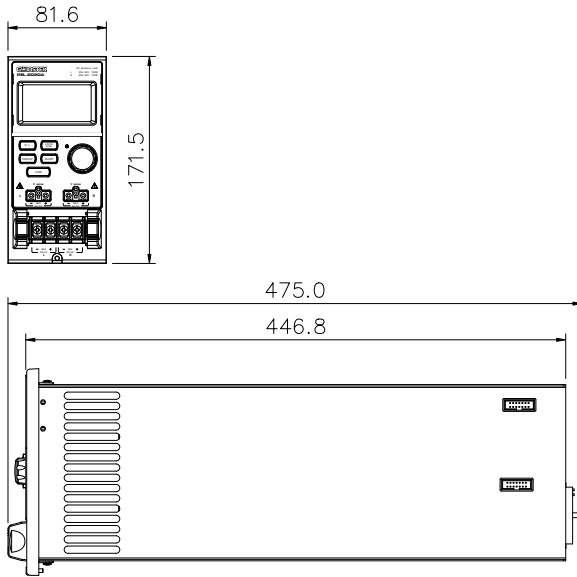

EC Declaration of Conformity

We

GOOD WILL INSTRUMENT CO., LTD.

No. 7-1, Jhongsing Rd, Tucheng Dist., New Taipei City 236, Taiwan

GOOD WILL INSTRUMENT (SUZHOU) CO., LTD.

No. 69 Lushan Road, Suzhou New District Jiangsu, China.

declare that the below mentioned product

Type of Product: Programmable Electronic Load

Model number: PEL-2004, PEL-2004A, PEL-2002, PEL-2002A.

Load module: PEL-2002, PEL-2020A, PEL-2030, PEL-2030A, PEL-2040, PEL-2040A, PEL-2041A, PEL-2041A.

are herewith confirmed to comply with the requirements set out in the Council Directive on the Approximation of the Law of Member States relating to Electromagnetic Compatibility (2004/108/EC and 2014/30/EU) and Low Voltage Directive (2006/95/EC and 2014/35/EU).

For the evaluation regarding the Electromagnetic Compatibility and Low Voltage Directive, the following standards were applied:

| ◎ EMC | |
|---|---|
| EN 61326-1 EN 61326-2-1 | Electrical equipment for measurement, control and laboratory use -- EMC requirements (2013) |
| Conducted Emission Radiated Emission EN55011: 2009+A1: 2010 | Electrostatic Discharge EN 61000-4-2: 2009 |
| Current Harmonics EN 61000-3-2: 2014 | Radiated Immunity EN 61000-4-3: 2006 +A1:2008+A2:2010 |
| Voltage Fluctuations EN 61000-3-3: 2013 | Electrical Fast Transients EN 61000-4-4: 2012 |
| ----- | Surge Immunity EN 61000-4-5: 2006 |
| ----- | Conducted Susceptibility EN 61000-4-6: 2014 |
| ----- | Power Frequency Magnetic Field EN 61000-4-8: 2010 |
| ----- | Voltage Dip/ Interruption EN 61000-4-11: 2004 |
| Low Voltage Equipment Directive 2006/95/EC and 2014/35/EU | |
| Safety Requirements | EN 61010-1: 2010 EN 61010-2-030: 2010 |

I NDEX

- Alarm configuration224
- All Chan save/recall
 - description101
- Baud rate configuration.....231
- Brightness & contrast.....219
- Calibration279
- Calibration key19
- CC vrange mode description.89
- CC+CV mode.....71
- Channel configuration
 - CC voltage range 192
 - Go/NoGo mode 208
 - Go/NoGo On/Off..... 209, 214
 - Independent setting198
 - Load delay time.....200
 - Parallel mode 211
 - Protection All Clear..... 191
 - Response time..... 206
 - SPEC test ON/OFF 209, 214
 - Step resolution 202
- Channel configuration
 - Configuration menu..... 187
 - OCP/OCV/OPP..... 188
- Channel configuration
 - Von voltage configuration . 194
- Channel configuration
 - Short..... 195
- Channel configuration
 - channel control 197
- Channel control configuration197, 270
- Channel control connection...59
- Channel control description ..93
- Channel control mode
 - description91
- Channel duration time
 - settings mode description ..83
- Cleaning the instrument.....7
- Clear key.....19
- Configuration mode
 - description87
- Connection
 - Channel control.....59
 - Frame link.....57
 - Go/NoGo control62
 - Remote sense50
 - Wire gauge46
 - Wire Inductance.....46
- Connection procedure48
- Constant power mode
 - description73
- Constant Resistance mode
 - description67
- Constant voltage + constant
 - current mode description...71
- Constant voltage mode
 - description70
- Declaration of conformity300
- Default Settings285
- Delay time mode description 92
- Dimensions298
- Display key30
- Display settings219
- Disposal instructions8
- Dynamic constant current
 - mode description65
- Dynamic loads Constant
 - Resistance mode description68
- EC Declaration of Conformity300

| | | | |
|----------------------------|----------|-------------------------------|--------|
| Operation..... | 123 | Program Sequences | 156 |
| R/L keys | 124 | Programming | 156 |
| Shorting | 127 | Recall default chain | 163 |
| Static..... | 125 | Recall default sequence..... | 160 |
| Lock key | 19 | Run Sequence..... | 176 |
| Mainframe configuration | | Save chain..... | 163 |
| alarm sound | 224 | Save Program chain..... | 163 |
| Brightness & contrast..... | 219 | Save sequence | 160 |
| Configuration menu..... | 215 | Sequence loop | 172 |
| Frame control..... | 221 | Trig out | 174 |
| Go/NoGo Tone | 225 | Measurement types..... | 15, 16 |
| Knob type | 223 | Memory data description..... | 98 |
| Language | 229 | Number pad..... | 19 |
| Load menu | 217 | OCP test automation..... | 179 |
| Slave knob | 227 | OCP Test Automation | |
| Speaker | 218 | description | 85 |
| System Info..... | 216 | Operating configurations | |
| Utility menu | 216 | mode description | 89 |
| Mainframe operation | | Operating Description | 63 |
| CC Dynamic mode..... | 135 | Operating Modes | |
| CC Mode..... | 133 | Channel duration time | |
| CC Range..... | 134 | settings..... | 83 |
| CC Static mode | 137 | Configuration..... | 87 |
| CC Static Values..... | 138 | Configuration - Over current | |
| Channel duration time | | protection | 88 |
| settings | 174 | Configuration - Over power | |
| Channel Selection | 131, 132 | protection | 89 |
| CP Current limit | 153 | Configuration - Over voltage | |
| CP mode | 152 | protection | 88 |
| CP Power values..... | 153 | Constant current - Go/NoGo66 | |
| CP range | 155 | Constant current - Slew rate | 66 |
| CR Range..... | 141 | Constant current -Dynamic .. | 65 |
| CR Static Parameters..... | 145 | Constant current -static..... | 65 |
| CR Dynamic mode | 142 | Constant Power..... | 73 |
| CR mode | 141 | Constant Resistance..... | 67 |
| CR Static mode | 145 | Constant Resistance - | |
| CV Current limit..... | 149 | Dynamic loading..... | 68 |
| CV mode | 148 | Constant Resistance - Slew | |
| CV response speed | 151 | rate..... | 69 |
| CV Voltage values | 149 | Constant Resistance | |
| Edit Sequence..... | 169 | Go/NoGo | 69 |
| OCP test automation..... | 179 | Constant Voltage | 70 |
| Program chain..... | 161 | Constant Voltage - Response | |
| Program Execution..... | 163 | speed..... | 72 |

| | | | |
|--|-----|--|-----|
| Constant Voltage + Constant Current Mode..... | 71 | Over voltage mode description..... | 88 |
| Constant Voltage -Go/NoGo | 72 | Overview | 13 |
| Constant Voltage -levels | 70 | Display Overview | 23 |
| External Voltage Control..... | 93 | Front panel | 17 |
| File format..... | 102 | LED display | 34 |
| File System | 97 | Load module..... | 30 |
| Go/NoGo..... | 79 | Rear Panel..... | 27 |
| Interface..... | 97 | Parallel Dynamic loading description..... | 86 |
| Memory data | 98 | pass/fail test multiple step tutorial | 105 |
| Operating Configuration s - Von Voltage..... | 90 | Power key | 22 |
| Operating Configurations.... | 89 | Power supply Safety information..... | 7 |
| Operating Configurations - CC vrange..... | 89 | Power up | 43 |
| Operating Configurations - independent | 91 | Power up sequence | 43 |
| Operating Configurations - Load D-Time | 92 | Preset data description | 98 |
| Operating Configurations - Short | 91 | Preset key | 20 |
| Operating Configurations - Step Resolution | 92 | Program Chain mode description..... | 79 |
| Parallel Dynamic Loading ... | 86 | Program mode description ... | 77 |
| Preset data..... | 98 | Protection All clear..... | 191 |
| Program Chain | 79 | Quick save Presets to internal memory | 263 |
| Reverse voltage protection .. | 89 | R/L key..... | 30 |
| Run Program | 77 | Rack mount installation..... | 41 |
| save/recall All Chan..... | 101 | Range Chart | 280 |
| SEQ data..... | 99 | Recall factory defaults | 266 |
| Sequences..... | 80 | Recall Memory data to USB | 251 |
| Setup data | 99 | Recall Presets - Framelink ... | 265 |
| Trig Out..... | 82 | Recall Setups - Framelink.... | 264 |
| USB save/recall..... | 101 | Remote sense connections..... | 50 |
| Operation | | Response speed constant voltage mode description.. | 72 |
| Contents | 119 | Response time | 206 |
| Local load..... | 123 | Reverse voltage protection.... | 89 |
| Operation Environment | 7 | RS232 configuration | 231 |
| Operation keys..... | 20 | RS-232C configuration..... | 268 |
| Over Current mode description..... | 88 | Safety Instructions..... | 5 |
| Over power mode description | 89 | Safety symbols | 5 |
| Over protection configuration | 188 | Save Memory data..... | 237 |

- Save Memory data to USB ...251
- Save Preset memory239
- Save presets to USB.....255
- Save Sequences to USB.....259
- Save setup memory.....241
- Save setup to USB248
- Save to internal memory237, 243
- Save to internal setup memory241
- Save/Recall
 - default USB path 243
 - FrameLink Preset Recall..... 265
 - FrameLink Setup Recall..... 264
 - Preset memory 239
 - Quick save Presets to internal memory 263
 - Recall factory defaults 266
 - Recall Memory data to USB251
 - Save Memory data to USB.. 251
 - Save Preset Memory 239
 - Save presets to USB..... 255
 - Save SEQ (Sequences) to USB259
 - Save setup to USB..... 248
 - Save to internal Memory 243
 - Save to setup Memory 241
 - Setup memory..... 241
 - USB path..... 243
- Save/Recall
 - File menu 236
 - Memory data..... 237
 - Save to internal Memory 237
- Selector Knob.....20
- SEQ data description99
- Sequence editing/creating...169
- Sequence mode description...80
- Sequences mode description .77
- service contance point276
- Setup data description.....99
- Shift key.....21
- Short configuration195
- Short key33
- Shorting mode description91
- Slave knob
 - settings..... 227
- Slave knob
 - description.....32
- Slew rage constant current
 - mode description66
- Slew rate Constant Resistance
 - mode description69
- Speaker Settings218
- Specifications287
 - PEL-2030A 291
- Static constant current mode
 - description65
- Static/ Dynamic key32
- Step resolution.....202
- Step Resolution mode
 - description92
- Storage Environment.....8
- System Info216
- System Keys.....18
- Terminals.....31
- Trig out174
- Trig out mode description82
- Tutorials
 - Channel control.....116
 - Frame link.....114
 - General configuration options118
 - Local load105
 - Parallel load.....109
 - Program113
 - Single load107
- Tutorials
 - Basic Operation.....104
 - Twisted pair description47
 - UK power cord9
 - USB configuration.....234
 - USB path.....243
 - USB remote interface
 - connection.....275
 - USB save/recall description 101
 - Utility Menu.....216
 - View parallel information213
 - Voltage levels constant
 - voltage mode description ..70

| | | | |
|------------------------------|-----|------------------------|----|
| Voltage sense terminal..... | 31 | Wire gauge | 45 |
| Von voltage configuration .. | 194 | Wire induction..... | 46 |
| Von voltage mode description | 90 | Wiring procedure | 48 |
| Wire Connections | 45 | | |