DC POWER SUPPLY

GPS-S SERIES
(ANALOG/DIGITAL TYPE)

User Manual

ISO-9001 CERTIFIED MANUFACTURER



CONTENTS

SECTION	PAGE
1. INTRODUCTION.....	1
2. SPECIFICATIONS.....	2
2-1 General	2
2-2 Constant Voltage Operation	3
2-3 Constant Current Operation	3
2-4 Indicator Meter	3
2-5 Insulation	4
3. THEORY OF OPERATION	4
4. PANEL CONTROLS AND INDICATORS.....	6
4-1 Front Panel.....	6
4-2 Rear Panel.....	6
5. OPERATION INSTRUCTIONS.....	10
5-1 Precaution.....	10
5-2 Setting Current Limit	10
5-3 Constant Voltage/Constant Current Characteristic.....	10
5-4 Operation Mode.....	12
6. MAINTANCE.....	18
6-1 Fuse Replacement	18
6-2 Line Voltage Conversion	18
6-3 Adjustments.....	18
6-4 Cleaning.....	19

1. INTRODUCTION

The regulated DC power supply have been designed to provide the most often required in the laboratory. schools and production Lines.

The output voltage is continuously adjustable between 0 to rating voltage in one range by means of a coarse and fine potentiometer , the load current may have any value from 0 rating current and adjusted by means of a coarse and fine potentiometer. Both output can accurately read-on voltmeter and ammeter.

Both stability and ripple are extremely good to meet the requirements of modern circuit design. The unit can be used as either constant voltage or current source. The various operation mode are described in more detail in the Operation Instruction section.

For applications when output greater than V or A is need. the unit can be connected up in series or parallel.

For application in audio production lines. the continuous or dynamic load internal selectable.

2. SPECIFICATIONS

2-1 General

Main supply

100V/120V/220V/240V $\pm 10\%$ 50/60 Hz (Switch selectable)

Rating, dimension and weight

see Table 2-1.

Table 2-1

MODEL	Max. Rating		Input Rating		FUSE Type and Rating				Weight Kg
	Volts (V)	Amps (A)	Watts	VA	100V/120V		220V/240V		
GPS-1830	18	3	120	150	T 2A 250V	T 1A 250V			4.0
GPS-1830D	18	3	120	150	T 2A 250V	T 1A 250V			4.0
GPS-1850	18	5	190	230	T 2.5A 250V	T 1.25A 250V			5.5
GPS-1850D	18	5	190	230	T 2.5A 250V	T 1.25A 250V			5.5
GPS-3030	30	3	160	200	T 2.5A 250V	T 1.25A 250V			5.0
GPS-3030D	30	3	160	200	T 2.5A 250V	T 1.25A 250V			5.0
GPS-6010	60	1	120	150	T 2A 250V	T 1A 250V			4.0

Dimensions : 128 (W) X 145 (H) X 285 (D) mm



WARNING. Voltages more than 60V DC are a lethal shock hazard to the user. Be careful when connecting power supplies in series to achieve voltages higher than 60V DC total or 60V DC between any connection and earth ground.

Operation mode

Single or Tracking (Series or Parallel) operation (two units).

Operation Environment : Indoor use

Altitude up to 2000 m

Installation Category II

Pollution degree 2

Operation Temperature & Humidity 0°C to 40°C, <80%
 Storage Temperature & Humidity -10°C to 70°C, <70%
 Accessories

Test Lead (current $\leq 4A$)1.
 (4A \leq current $\leq 10A$)
 Operation Manual1.

2-2 Constant Voltage Operation

- (1) Output voltage ranges 0 to rating voltage continuously adjustable.
- (2) Voltage regulation
 line regulation $\leq 0.01\% + 3mV$.
 load regulation $\leq 0.01\% + 3mV$ (rating current $\leq 3A$).
 load regulation $\leq 0.01\% + 5mV$ (rating current $> 3A$).
- (3) Recovery time $\leq 100\mu s$ (50% Load change, minimum load 0.5A)
- (4) Ripple & Noise $\leq 0.5mV_{rms}$ (5Hz~1MHz) (rating current $\leq 3A$).
 Ripple & Noise $\leq 1.0mV_{rms}$ (5Hz~1MHz) (rating current $> 3A$).
- (5) Temperature coefficient $\leq 300PPM/^{\circ}C$.

2-3 Constant Current Operation

- (1) Output current range 0 to rating current continuously adjustable.
- (2) Current regulation
 line regulation $\leq 0.2\% + 3mA$.
 load regulation $\leq 0.2\% + 3mA$.
- (3) Ripple & Noise $\leq 3mArms$.

2 4 Indicator Meter

- (1) Digital Type
 Display: 3 1/2 Digits 0.5" Red LED DISPLAY (Voltage and current switchable).
 Accuracy: $\pm(0.5\%$ of rdg + 2 digits).

Voltage range: 19.99V of full scale (rating voltage \leq 18V).
199.9V of full scale (rating voltage \geq 20V).
Current range: 1.999A of full scale (rating current $<$ 2A).
19.99A of full scale (rating current \geq 2A).

(2) Analog Type

Meter: Voltmeter and Ammeter each one.

Class: 2.5

Dimensions: 50x50 m/m.

2-5 Insulation

Between chassis and output terminal.

20M Ω or above (DC500V).

Between chassis and AC cord.

30MR or above (DC500V).

3. THEORY OF OPERATION

The power supply consists of an AC input circuit and transformer, a bias supply consisting of a rectifier and filter and reference voltage source, a main regulator circuit consisting of the main rectifier and filter, a series regulator, a current comparator, a voltage comparator, a reference voltage amplifier, a remote control and a relay control circuit.

The circuit element are several of integrated circuit (U101, U102, U103, U104, U105, U106).

The circuit arrangement is shown in block diagram from Fig. 1.

The circuit is discussed with reference to the block diagram Function Description.

Single phase input power is applied to transformer through the input circuit.

Auxiliary rectifier D1021-D1024 provides a bias voltage filtered by capacitor C103, C104 for the preregulator U101, Q105, Q106, that provides a regulator voltage for element of action.

The main rectifier, a full wave bridge rectifier, provides the power which is filtered by capacitor C101 and then regulated via a series regulator and deliver to the output.

U105 acted as a current limiter. When current is over predominante rating, it acted and decreased the current U102 provides a reference voltage for U103A, U103B, U103 is a invertor amplifier, U105 is a current comparator. Both via OR gate and driver amplifier to series control Q101, Q102.

The relay control circuit provides limited power dissipation is series regulator.

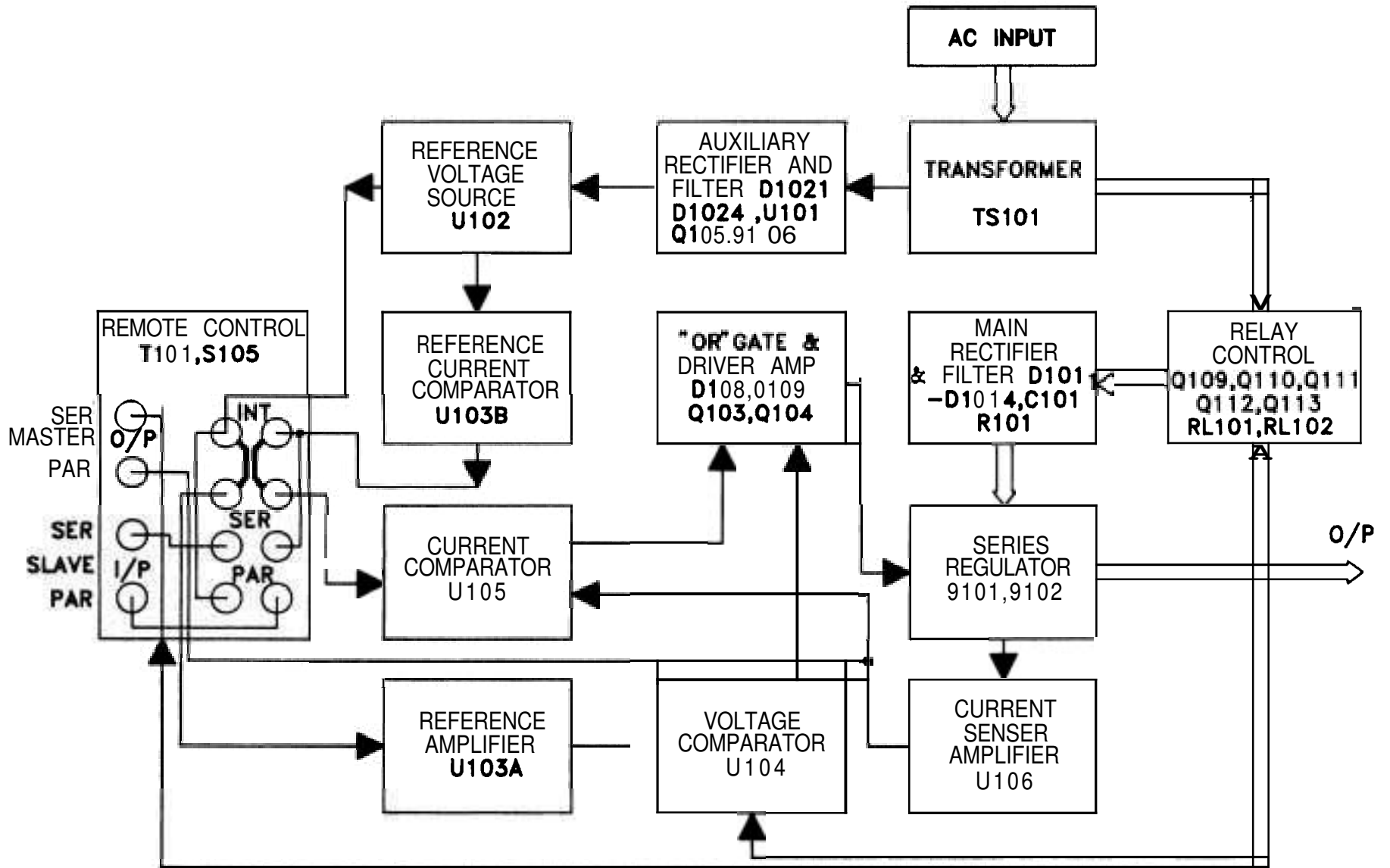

Fig. 1 Block Diagram

4. PANEL CONTROLS AND INDICATORS

4-1 Front panel

- | | | |
|---|-----------------------|--|
| ① | CV indicator | lights when the power turn on and constant voltage operation. |
| ② | CC indicator | lights when this unit in constant current operation. |
| ③ | Voltage coarse | for the coarse adjustment of the output voltage. |
| ④ | Voltage fine | for the fine adjustment of the output voltage. |
| ⑤ | Current coarse | for the coarse adjustment of the output current. |
| ⑥ | Current fine | for the fine adjustment of the output current. |
| ⑦ | "+" output terminal | positive polarity (Red). |
| ⑧ | "GND terminal | earth and chassis ground (Green). |
| ⑨ | "-" output terminal | negative polarity (Black). |
| ⑩ | meter | indicates the output voltage (Analog type). |
| ⑪ | meter | indicates the output voltage or current (Digital type). |
| ⑫ | A/V selects switch | indicates the output current (Analog type). |
| | Power control | selects the meter indicates of the output voltage or current (Digital type). |
| ⑭ | Current HI/LO control | on/off switch.
current indicates HI/LO range SELECTS. |

4-2 Rear panel

- | | | |
|---|------------------------|---|
| ⑮ | Fuse holder | |
| ⑯ | Power cord | |
| ⑰ | AC selects switch | With ⑰ switch selects the line voltage at the high end (Right position) of the range 120V or 240V and at the low end (left position) of the range 100V or 220V. |
| ⑱ | AC selects switch | Selects the line Voltage is in the 100V-120V range (left position) or is in the 220V-240V range (Right position). |
| ⑲ | Master-Slave Switch | Selects for Master (internal control) or Slave (external remote control) tracking operation. |
| ⑳ | Input-Output connector | With ⑲ Master-Slave switch selects, permit from the Master unit (SER. or PAR.) output connected to Slave unit (SER. or PAR.) inputs. |

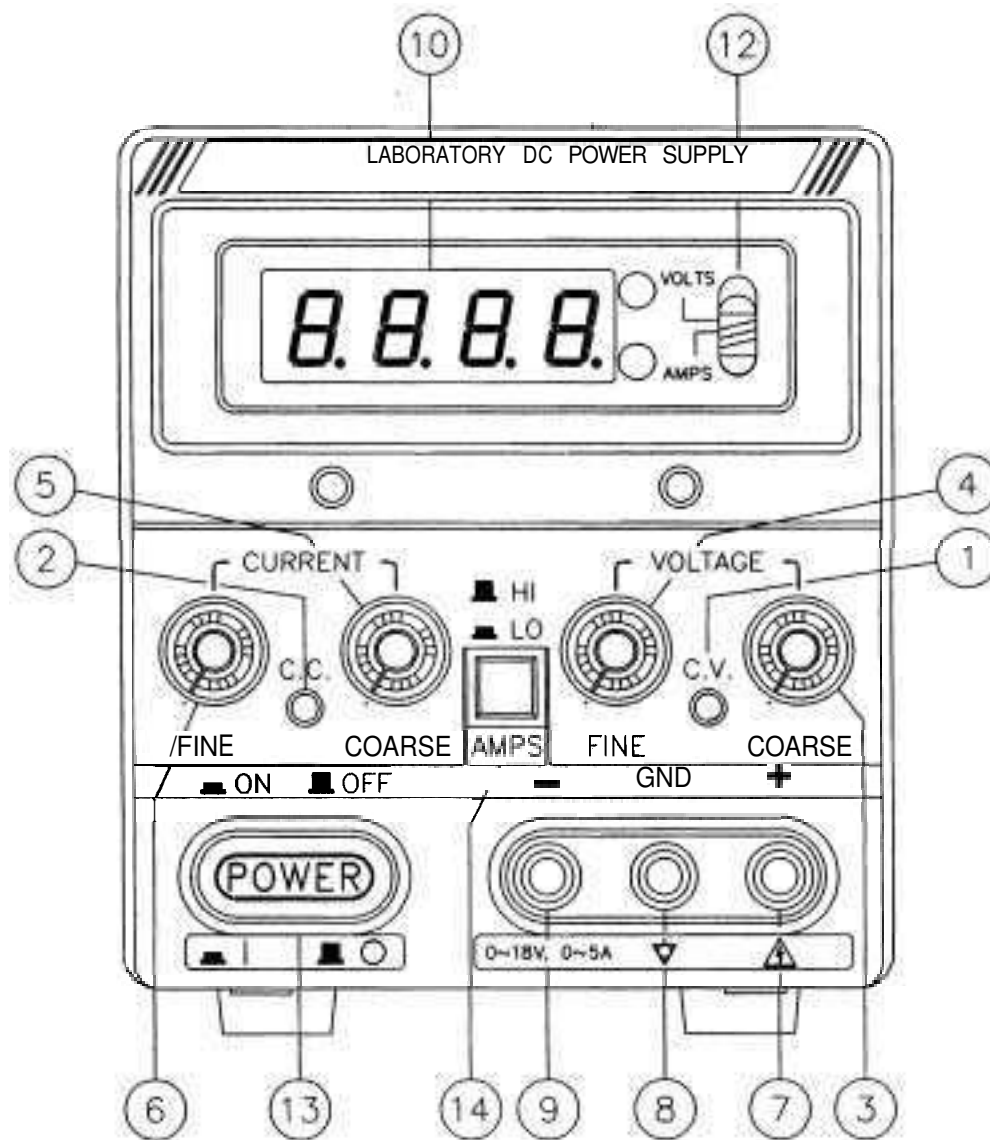

Fig. 4-1 Front Panel (Digital Type)

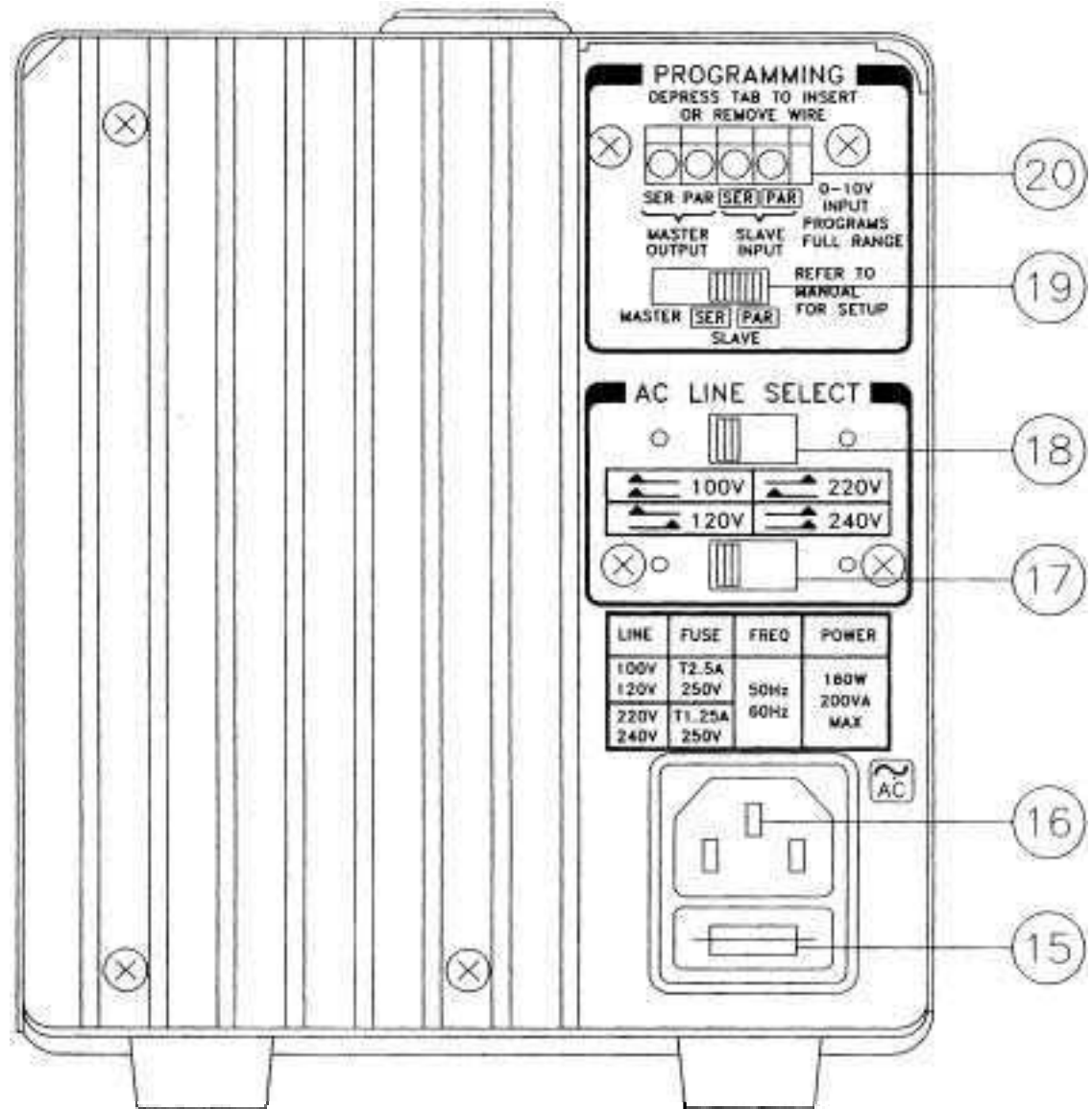

FIG. 4-3 REAR PANEL

5. OPERATION INSTRUCTIONS

5-1 Precaution

- (1) AC input
AC input should be within the range of line voltage $\pm 10\%$ 50/60Hz



WARNING. To avoid electrical shock, the power cord protective grounding conductor must be connected to ground.

- (2) Installation

Avoid using the supply in a place where ambient temperature exceeds 40°C . The heat sink located at the rear of the supply must have sufficient air space for radiation.



CAUTION. To avoid damaging the power supply, don't use it in a place where ambient temperature exceeds 40°C .

- (3) Output voltage overshoot

Voltage between output terminals never exceeds the present value when the power is turned on or off

5-2 Setting Current Limit

- (1) Determine the maximum safe current for the device to be powered.
- (2) Temporarily short the (+) and (-) terminals of the power supply together with a test lead.
- (3) Rotate the COARSE VOLTAGE control away from zero sufficiently for the CC indicator to light.
- (4) Adjust the CURRENT control for the desired current limit. Read the current **value** on the Ammeter.
- (5) The current limit (overload protection) has now been preset. Do not change the CURRENT control setting after this step.
- (6) Remove the short between the (+) and (-) terminals and hook up for constant voltage operation.

5-3 Constant **Voltage/Constant** Current Characteristic

The working characteristic of this series Power Supplies is called a constant **voltage/constant** current automatic crossover type. This permits continuous transition from constant current to constant voltage modes in response to the load change. The intersection of constant voltage and constant current modes is called the crossover point. Fig. 5-1 shows the relationship between this crossover point and the load.

For example, if the load is such that the power supply is operating in the constant voltage mode, a regulated output voltage is provided. The output voltage remains constant as the load increases, up until the point where the preset current limit is reached. At that point, the output current becomes constant and the output voltage drops in proportion to further increases in load. The crossover point is indicated by the front panel LED indicators. The crossover point is reached when the CV indicator goes off and the CC indicator comes on.

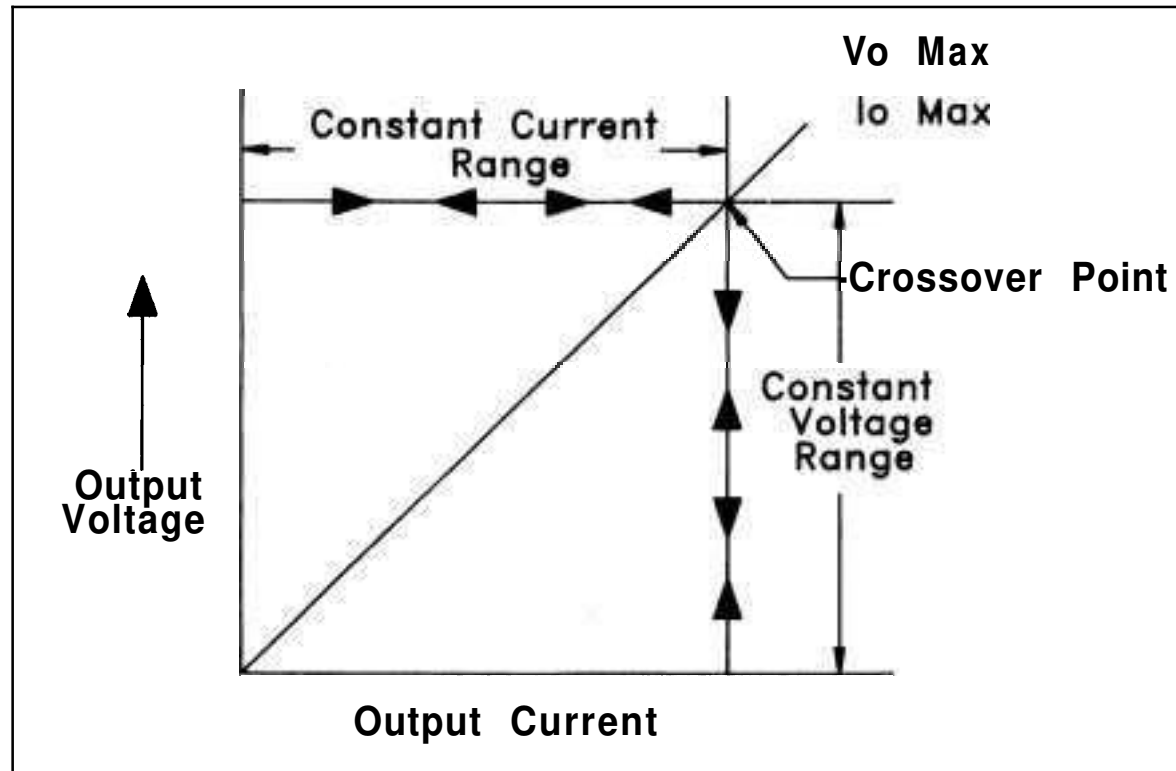

Fig. 5-1 Constant Voltage/Constant Current Characteristic.

Similarly, crossover from the constant current to the constant voltage mode automatically occurs from a decrease in load. A good example of this would be seen when charging a 12-volt battery. Initially, the open circuit voltage of the power supply may be preset for 13.8 volts. A low battery will place a heavy load on the supply and it will operate in the constant current mode, which may be adjusted for a 1 amp charging rate. As the battery becomes charged, and its voltage approaches 13.8 volts, its load decreases to the point where it no longer demands the full 1 amp charging rate. This is the crossover point where the power supply goes into the constant voltage mode.

5-4 Operation Mode

(1) Single Operation

Use the supply as it is for single operation.

- A. Set Power switch to "OFF" position.
- B. Make sure that line voltage is correct for the input power voltage.
- C. Plug power cord into the power outlet.
- D. Set Power switch to "ON" position.
- E. Adjust "Voltage" and "Current" control to the desired output voltage and current.
- F. Connect the external load to the output binding posts. Make sure both "+" and "-" terminals are connect correctly.

(2) Series Operation (only applied to the same models)

Two power supplies can be connected in series to provide higher voltage and rating current output. See Fig. 5-2 for the connection scheme.

- A. Set power switch to "OFF" position.
- B. Set the "MASTER" power supply INT-SLAVE switch to "INT" position and set the "SLAVE" power supply INT-SLAVE switch to "SER-SLAVE" position.
- C. From the "MASTER" power supply "SER" output terminal to "SLAVE" power supply "SER" input.
- D. Set power switch to "ON" position.

A WARNING. Voltage more than 60V DC are a lethal shock hazard to the user. Be careful when connecting power supplies in series to achieve voltage higher than 60V DC total or 60V DC between any connection and earth ground.

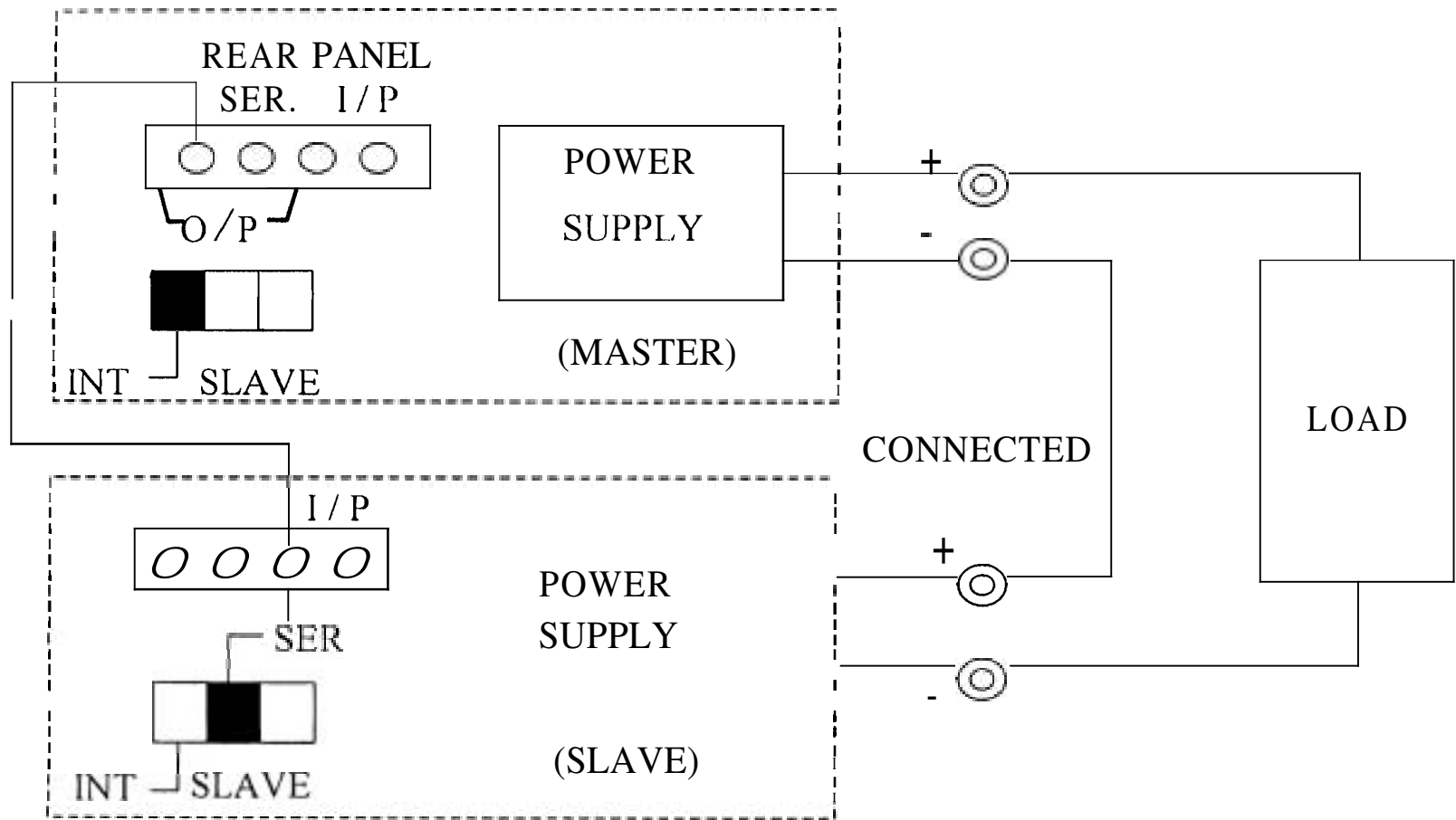

Fig. 5-2 Connecting Two Power Supplies in Series

- E. Set the SLAVE VOLTAGE and CURRENT control to maximum output.
- F. When connected in series, from the master VOLTAGE controls of each power supply exercise control over 0 to rating range. Add the two voltmeter readings together to determine the total output voltage, or an external voltmeter may be connect across the load.
- G. Load current may be monitored from either supply; the reading **will** be identical since they are connected in series. Also, since the supplies are connected in series, it is only necessary to set the current limit of the master power supply; the slave would set for maximum.

(3) Parallel Operation

Two power supplies may be connected in parallel to provide rating voltage and higher current output. See Fig. 5-3 for the connection scheme.

- A. Set power switch to "**OFF**" position.
- B. Set the "Master" power supply INT-SLAVE switch to "INT" position and set the "SLAVE power supply INT-SLAVE switch to "PAR-SLAVE position.
- C. From the "MASTER" power supply "PAR" output terminal connected to "SLAVE power supply "PAR" input.
- D. When connected in parallel the VOLTAGE controls of each power supply exercise control over a 0 to rating range. Add the two ammeter readings together to determine the total output current or an external ammeter may be connected series the load.
- E. The output voltage may be monitored from either supply; the readings **will** be identical since they are connected in parallel. Also, since the supplies are connected in parallel, it is only necessary to set the current limit of the master power supply; the slave would set for maximum.
- F. Set power switch to "ON" position.
- G. Set the SLAVE VOLTAGE and CURRENT control to maximum output.
- H. Set the MASTER output voltage lower than **0.2-0.5V** of SLAVE output voltage, this point is very important.

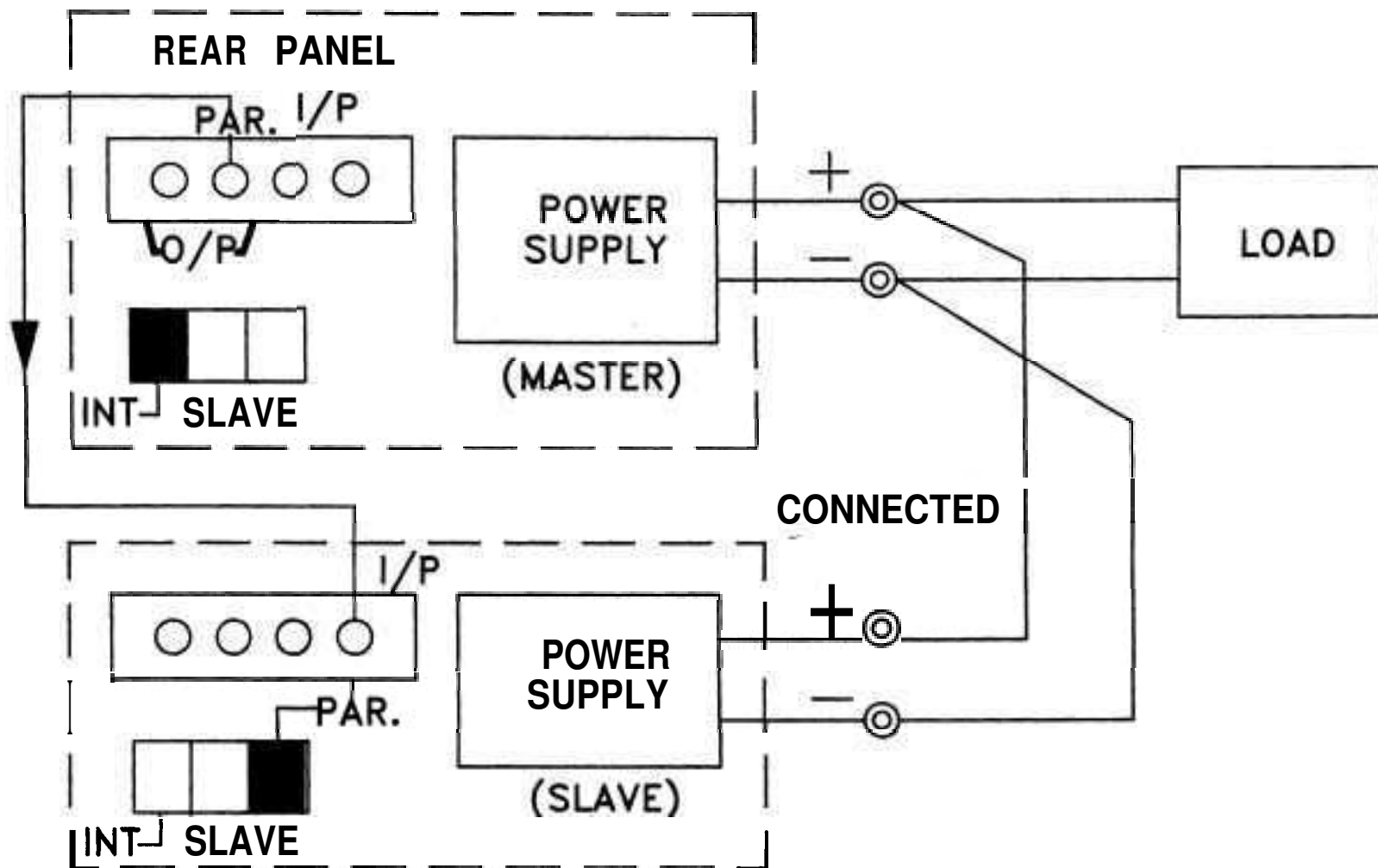
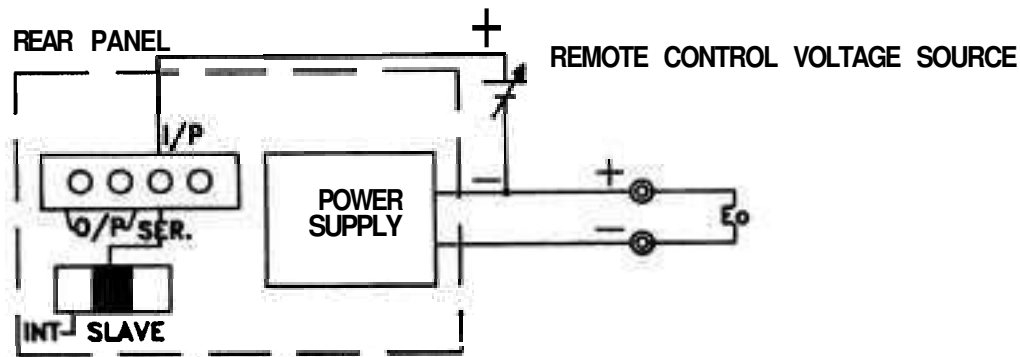

Fig. 5-3 Connecting Two Power Supplies in Parallel.

(4) Remote control of output voltage

The output voltage of the power supply can be remote-controlled with an external voltage, the connection scheme as follow, See Fig. 5-4.

Fig. 5-4



- A. Set the power supply INT-SLAVE switch to "SER-SLAVE" position.
- B. The "+" line of control voltage source is connected to the "SER input terminal and the "-" line of control voltage source is connected to the power supply output "+" terminal.
- C. The output voltage E_o calculate as follows formula:

$$E_o = \frac{E_r \times E_c}{10}$$

E_o : Output voltage of the power supply.

E_r : Rated voltage of the power supply.

E_c : Remote control voltage.

$0 \leq E_c \leq \text{approx. } 10V$

- D. For the remote voltage source E_c , use a device which provides a stable, low noise voltage source (a GOOD WILL GPR, GPC series power supply or an equivalent device).

(5) Remote control of output current

The output current of the power supply can be remote-controlled with an external voltage, the connection scheme as follow, See Fig. '5-5.

Fig. 5-5

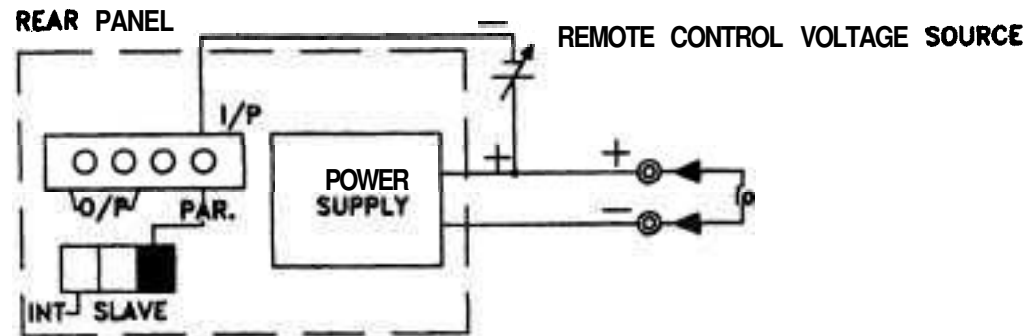

- Set the power supply INT-SLAVE switch to "PAR-SLAVE" position.
- The "-" line of control voltage source is connected to the "PAR" input terminal and the "+" line of control voltage source is connected to the power supply output "+" terminal.
- The output current I_o calculate as follows formula:

$$I_o = \frac{I_r \times E_c}{10}$$

I_o : Output current of the power supply.

I_r : Rated current of the power supply.

E_c : Remote control voltage.

$0 \leq E_c \leq \text{approx. } 10V$

- For the remote control voltage source E_c , use a device which provides a stable, low noise voltage source (a GOODWILL GPR, GPC series power supply or an equivalent device).

6. MAINTENANCE

WARNING

The following **instructions are** for use by qualified personnel only. To avoid electrical shock, do not perform any servicing other than contained in the operating instructions unless you are qualified to do so.

6-1 Fuse Replacement

If the fuse blows, the CV or CC indicators will not light and the power supply will not operate. The fuse should not normally open unless a problem has developed in the unit. Try to determine and correct the cause of the blown fuse, then replace only with a fuse of the correct rating and type.

The fuse is located on the rear panel (see Fig. 4-3).



WARNING. For continued fire protection. Replace fuse only with 250V fuse of the specified type and rating. And disconnect the power cord before replacing fuse.

6-2 Line Voltage Conversion

The primary winding of the power transformer is tapped to permit operation from 100,120,220, or 240 VAC, 50/60 Hz line voltage. Conversion from one line voltage to another is done by change AC selects switch as shown in Fig. 4-3.

The rear panel identifies the line voltage to which the unit was factory setted. To convert to a different line voltage, perform the following procedure:

- (1) Make sure the power cord is unplugged.
- (2) Change the AC selects switch to the desired line voltage position.
- (3) A change in line voltage may also require a corresponding change of fuse value. Install the correct fuse value as listed on rear panel.

6-3 Adjustments

This unit was accurately adjusted at the factory before shipment. Readjustment is recommended only if repairs have been made in a circuit affecting adjustment accuracy, or if you have a reason to believe the unit is out of adjustment. However, adjustments should be attempted only if a multimeter with an accuracy of $\pm 0.1\%$ dcv or better is available (GOOD WILL Model GDM-8035G or equivalent).

If readjustment is required, use the following procedure. Locations of the adjustments are shown in Fig. 6-1 and Fig. 6-2.

- (1) Adjustment of the Rating Voltage
 - A. Connect an accurate ($\pm 0.1\%$) external multimeter to measure the dc voltage at output terminals of the power supply.
 - B. Set the COARSE and FINE VOLTAGE controls to minimum (fully counterclockwise).
 - C. Turn the COARSE and FINE VOLTAGE controls to maximum (fully clockwise).
 - D. Adjust trimmer pot **VR105** for a reading of rate **voltsx1.05** on the multimeter.
 - E. Set the COARSE and FINE VOLTAGE controls for a reading of rate volts on the multimeter.
 - F. Adjust trimmer pot **VR301 (VR201 digital type)** for a reading of rate volts on the voltmeter (Digital Panel meter, digital type) of the power supply.
- (2) Adjustment of the Rating Current
 - A. Set the CURRENT control to minimum (fully counterclockwise).
 - B. Connect the external multimeter to measure dc current at the output terminals of the power supply.
 - C. Set the COARSE and FINE CURRENT controls to minimum (fully counterclockwise).
 - D. Adjust trimmer pot **VR107** for reading of **0** amps on the multimeter.
 - E. Set the COARSE and FINE VOLTAGE controls to a centered position.
 - F. Setting and turn the COARSE and FINE CURRENT controls to maximum (fully clockwise).
 - G. Adjust trimmer pot **VR108** for a reading of **1/2rate** ampsx1.05 on the multimeter. (LO current)
 - H. Adjust trimmer pot **VR109** for a reading of rate ampsx1.05 on the multimeter. (HI current)
 - I. Readjust the CURRENT control for a reading of rate amps on the multimeter.
 - J. Adjust trimmer pot **VR110(HI), VR111(LO)** to calibrate the Ammeter or Digital panel meter of the power supply for the same reading as the multimeter.

6 4 Cleaning

To clean the power supply, use a soft cloth dampened in a solution of mild detergent and water. Do not spray cleaner directly onto the instrument, since it may leak into the cabinet and cause damage.

Do not use chemicals containing benzine, benzene, toluene, xylene, acetone, or similar solvents.

Do not use abrasive cleaners on any portion of the power supply.

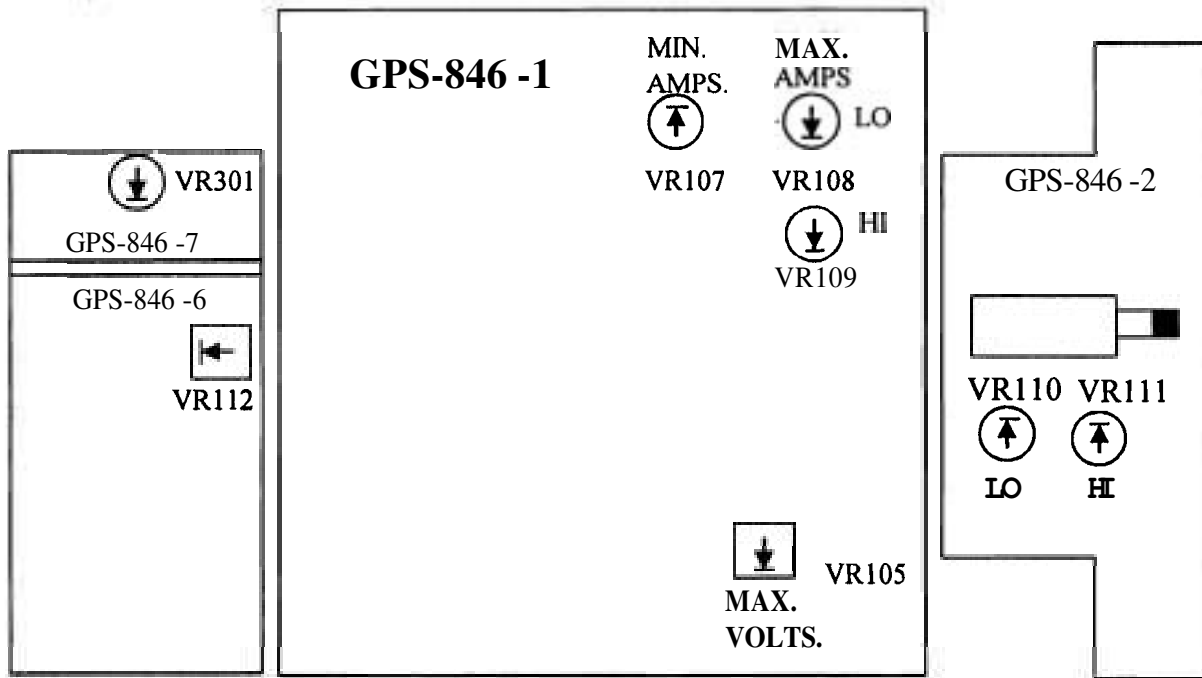

Fig. 6-1 Adjustment Location

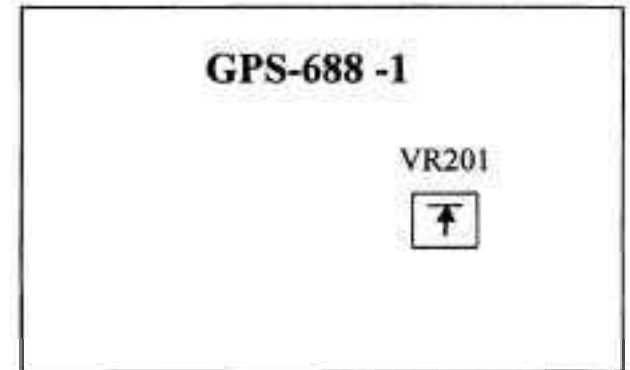

Fig. 6-2 Adjustment Location