

1433 SERIES

High-Accuracy Decade Resistor

User and Service Manual



Copyright © 2003 IET Labs, Inc.

1433 im/December, 2003



IET LABS, INC.
formerly manufacturer by
GenRad

534 Main Street, Westbury, NY 11590 www.ietlabs.com
TEL: (516) 334-5959 • (800) 899-8438 • FAX: (516) 334-5988

WARRANTY

We warrant that this product is free from defects in material and workmanship and, when properly used, will perform in accordance with applicable IET specifications. If within one year after original shipment, it is found not to meet this standard, it will be repaired or, at the option of IET, replaced at no charge when returned to IET. Changes in this product not approved by IET or application of voltages or currents greater than those allowed by the specifications shall void this warranty. IET shall not be liable for any indirect, special, or consequential damages, even if notice has been given to the possibility of such damages.

THIS WARRANTY IS IN LIEU OF ALL OTHER WARRANTIES, EXPRESSED OR IMPLIED, INCLUDING BUT NOT LIMITED TO, ANY IMPLIED WARRANTY OF MERCHANTABILITY OR FITNESS FOR ANY PARTICULAR PURPOSE.

Contents

WARRANTY	iii
WARNING	v
CAUTION	v
Chapter 1	
INTRODUCTION	1
1.1 Product Overview	1
1.2 Accessories Included	2
1.3 Accessories/Options Available	2
Chapter 2	
SPECIFICATIONS	3
Chapter 3	
OPERATION	5
3.1 Installation	5
3.2 Connections	5
3.3 Dial Readout	5
3.4 Principles of Operation	5
Chapter 4	
MAINTENANCE	8
4.1 Customer Service	8
4.2 Instrument Return	8

Figures

Figure 1.1 1433 Series High Accuracy Decade Resistor	1
Figure 3.1 A simplified equivalent circuit for a decade box with the low (L) terminal tied to case	5
Figure 3.2 Equivalent three terminal circuit for a decade box with neither terminal tied to case	6
Figure 3.3 Approximation of distributed capacitance effects	7



WARNING



OBSERVE ALL SAFETY RULES
WHEN WORKING WITH HIGH VOLTAGES OR LINE VOLTAGES.

**Dangerous voltages may be present inside this instrument. Do not open the case
Refer servicing to qualified personnel**

HIGH VOLTAGES MAY BE PRESENT AT THE TERMINALS OF THIS INSTRUMENT

WHENEVER HAZARDOUS VOLTAGES (> 45 V) ARE USED, TAKE ALL MEASURES TO
AVOID ACCIDENTAL CONTACT WITH ANY LIVE COMPONENTS.

USE MAXIMUM INSULATION AND MINIMIZE THE USE OF BARE
CONDUCTORS WHEN USING THIS INSTRUMENT.

Use extreme caution when working with bare conductors or bus bars.

WHEN WORKING WITH HIGH VOLTAGES, POST WARNING SIGNS AND
KEEP UNREQUIRED PERSONNEL SAFELY AWAY.



CAUTION



DO NOT APPLY ANY VOLTAGES OR CURRENTS TO THE TERMINALS OF THIS
INSTRUMENT IN EXCESS OF THE MAXIMUM LIMITS INDICATED ON
THE FRONT PANEL OR THE OPERATING GUIDE LABEL.

Chapter 1

INTRODUCTION

1.1 Product Overview

The **1433** Decade Resistors are a family of instruments providing a very broad choice of high-performance resistance sources. Any number of decades from one to eleven is available.

The **1433** is a precision resistance source with excellent characteristics of stability, temperature coefficient, power coefficient, and frequency response.

There are over 30 models available covering a wide resistance range from 1 m Ω to over 111 M Ω . The **1433** Series employs stable very low resistance switches with silver alloy contacts. A special design keeps zero-resistance to less than 1 m Ω per decade. Self-cleaning keeps the silver contacts from becoming tarnished when unused, or when only low currents are passed through them. This is most often the case when only minute test currents are drawn by digital multimeters or other test instruments. Contact resistance is stable and remains low and repeatable.

The dials, labeled **0** to **X**(=10), offer smooth rotation from position to position with no stops. Each dial has the overlap **X**(10) position for maximum convenience and flexibility in setting and adjusting resistance values. The resistance per step and maximum current of each dial are clearly shown on the front panel. Electrical shielding is provided by an attractive aluminum cabinet and front panel. The resistance elements have no electrical connection to the cabinet and panel; a separate shield terminal is provided.

High-quality gold-plated tellurium-copper binding posts serve to minimize the thermal emf effects which can introduce errors into dc resistance measurements. All

other conductors within the instrument, as well as the solder employed, contain no metals or junctions that contribute to thermal emf problems.

With a resolution as low as 1 m Ω and a maximum available resistance of over 111 M Ω , the **1433** series may be used for exacting precision measurement applications requiring high accuracy, good stability, and low zero-resistance. They can be used as components of dc and ac bridges, for calibration, as transfer standards, and as RTD simulators.

The **1433** Series may be rack-mounted to serve as components in measurement and control systems.

This series is part of a family of resistance substitutes suited to fill many engineering and testing needs. Consult IET for:

High-power substitutes - *up to 400 W*

High-resistance substitutes - *to 1 T Ω*

RTD simulators

Laboratory-standard-grade substitutes - *to 1 ppm accuracy*

Programmable substitutes - *IEEE-488 or BCD.*



Figure 1.1. 1433 Series High Accuracy Decade Resistor

1.2 Accessories Included

Table 1-3

Item	Quantity
Instruction Manual	1
Calibration Certificate	1

1.3 Accessories/Options Available

Table 1-4

Item	Part Number
Rack Mount Kit for 4 dial units	1433-50
Rack Mount Kit for 5 dial units	1433-51
Rack Mount Kit for 6 dial units	1433-52
Rack Mount Kit for 7 dial units	1433-53

Chapter 2 SPECIFICATIONS

Range:

1 m Ω to 111.111.111.110 Ω in 1 m Ω steps.

Overall Accuracy:

The difference between the resistance at any setting and at the Zero setting is equal to the indicated value \pm (0.01% + 2 m Ω)

Decade Specifications

R/step (Ω)	Total R (Ω)	Accuracy of R Increments	Stability ppm/yr	L/step (μ H)	Max Input	Power /step (W)	Tempco ppm/ $^{\circ}$ C
0.001	0.01	\pm 4%	500	-	5 A	0.025	50
0.01	0.1	\pm 2%	500	0.01	4 A	0.16	20
0.1	1	\pm 0.4%	50	0.1	1.6 A	0.25	20
1	10	\pm 0.1%	20	0.15	800 mA	0.6	20
10	100	\pm 0.04%	20	0.55	250 mA	0.6	15
100	1000	\pm 0.01%	20	5	80 mA	0.6	5
1,000	10,000	\pm 0.01%	20	15	23 mA	0.5	5
10,000	100,000	\pm 0.01%	20	75	7 mA	0.5	5
100,000	1,000,000	\pm 0.01%	20	-	2.3 mA	0.5	5
1,000,000	10,000,000	\pm 0.01%	20	-	0.7 mA	0.5	10
10,000,000	100,000,000	\pm 0.01%	20	-	0.23 mA	0.1	10

Typical Frequency Characteristics:

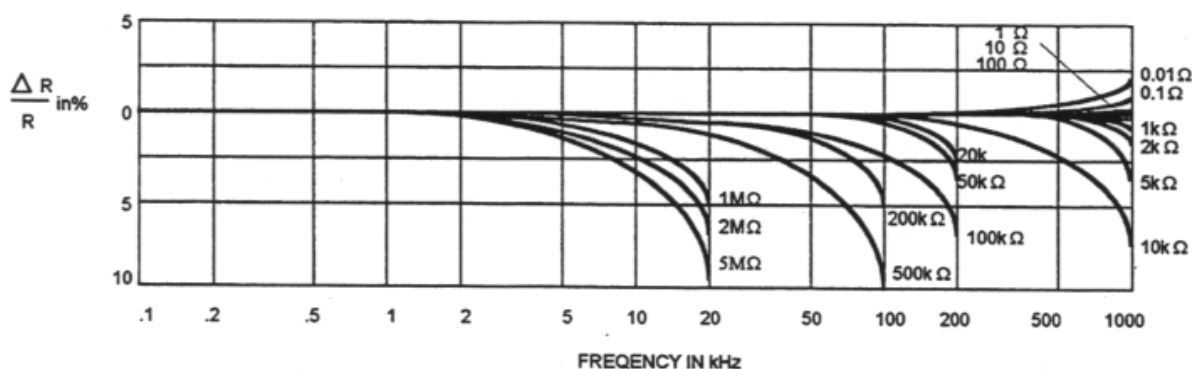

Typical Value of Zero Impedance:**Zero Resistance (Ro):**

0.001 Ω /decade at dc; 0.04 Ω /decade at 1 MHz; proportional to square root of frequency above 100 kHz.

Zero Inductance (Lo):

0. 1 μ H/decade + 0.2 μ H.

Effective Shunt Capacitance (C):

Value is determined largely by the highest decade in use. With the low terminal connected to the shield, a value of 15 to 20 pF/decade may be assumed, counting decades down from the highest. Thus, if the third decade from the top is the highest resistance, a value of 45 to 60 pF may be assumed. If the highest decade in the unit is in use, the effective capacitance is 15 to 20 pF, regardless of the settings of the lower-resistance decades.

Switches:

Continuous rotation; solid silver-alloy contacts; contact resistance of less than 1 m Ω ; capacitance of less than 1 pF between contacts; lifetime in excess of 1 million cycles.

Maximum voltage to case:

2000 V peak

Terminals:

Gold plated, tellurium-copper, low-thermal-emf binding posts on standard 3/4 inch spacing; shield terminal provided.

Mechanical:

Dimensions: in inches (mm)

Weight: in lb (kg)

	L	W	D	Wt
4 dial	12.3 (312)	3.5 (89)	5.0 (127)	3.5 (1.6)
5 dial	14.8 (375)	3.5 (89)	5.0 (127)	4.0 (1.8)
6 dial	17.3 (439)	3.5 (89)	5.0 (127)	4.5 (2.0)
7 dial	17.3 (439)	5.3 (135)	5.0 (127)	6.0 (2.7)

Environmental:

Operating: +10 to +40°C, <80% RH

Storage: -20 to +65°C

Supplied with unit:

Instruction manual

Calibration Certificate

Accessories available:

1433-50 Rack Mount Kit for 4-dial units

1433-51 Rack Mount Kit for 5-dial units

1433-52 Rack Mount Kit for 6-dial units

1433-53 Rack Mount Kit for 7-dial units

Ordering Information:

Catalog No.	Total (Ω)	Ohms /step	No. of dials
1433-01	1.11	0.001	3
1433-00	111.1	0.01	4
1433-02	1,111	0.1	4
1433-04	11,110	1	4
1433-06	111,100	10	4
1433-08	1,111,000	100	4
1433-09	11,110,000	1000	4
1433-09A	111,100,000	10,000	4
1433-10	1,111.1	0.01	5
1433-12	11,111	0.1	5
1433-14	111,110	1	5
1433-16	1,111,100	10	5
1433-18	11,111,000	100	5
1433-18A	111,110,000	1000	5
1433-19	1,111.11	0.001	6
1433-20	11,111.1	0.01	6
1433-22	111,111	0.1	6
1433-24	1,111,110	1	6
1433-26	11,111,100	10	6
1433-27	111,111,000	100	6
1433-28	11,111.11	0.001	7
1433-29	111,111.1	0.01	7
1433-31	1,111,111	0.1	7
1433-33	11,111,110	1	7
1433-34	111,111,100	10	7
1433-35	111,111,110	1	8
1433-36	1,111,111,100	10	8
1433-37	11,111,111,000	100	8
1433-38	111,111,110,000	1000	8
1433-39	1,111,111.11	0.001	9
1433-39A	11,111,111.1	0.01	9
1433-39B	111,111,111	0.1	9
1433-40A	11,111,111,110	0.001	10
1433-40	111,111,111.1	0.01	10
1433-41	111,111,111.11	0.001	11

Chapter 3 OPERATION

3.1 Installation

All models of the **1433** Decade Resistor are supplied as bench instruments but may be rack mounted. Installation in a standard 19-inch rack requires a Rack Mount Kit whose part number depends on the number of dials on the unit. Refer to paragraph 1.3

3.2 Connections

The terminals on the front panel of the **1433** are standard 3/4-inch-spaced binding posts that accept banana plugs, phone plugs, spade lugs, various clips, and wire sizes up to No. 12. The high (**H**) and low (**L**) binding posts are insulated from the panel and used for regular two-terminal applications. For grounded operation, connect the shorting link between the ground (**G**) terminal and the low (**L**) terminal. Refer to paragraph 3.4 for a detailed comparison of two- and three-terminal connections.

If switches have not been operated for an extended period, they should be rotated a few times to restore contact resistance to specifications.

3.3 Dial Readout

All **1433** decades have easy-to-read dials with numbered steps from **0** to **X** (= 10). When setting the decade switches, observe the decimal point on the panel and remember that **X** equals ten units. For example, the five dial **Model 1433-10** is set for a value of 54.3 Ω by setting the decade switches as follows:

$$0\ 5\ 4\ .\ 3\ 0 = 54.3\ \Omega$$

or

$$0\ 5\ 4\ .\ 2\ X = 54.3\ \Omega$$

Note that **X**, in the above example, is equal to a value of ten 0.01 W units in that decade, or one 0.1 Ω unit in the next decade to the left.

The following examples illustrates the result of setting all decades in the **1433-10** to X.

Dial setting: X X X . X X
Resistance value: 1 1 1 1 . 1 0 Ω

3.4 Principles of Operation

The best approximation of a complete equivalent circuit for a **1433** Decade Resistor is shown in Figure 3-1.

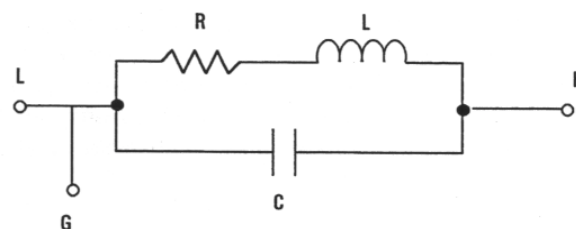

Figure 3-1. A simplified equivalent circuit for a decade box with the low (L) terminal tied to case

In Figure 3-1:

R = setting of the decade box.

$$L = L_0 = N_1 \Delta L_1 + N_2 \Delta L_2 + \dots$$

where $L_0 \approx 0.1\ \mu\text{H}$ per decade x number of decades in unit + 0.2 μH .

$\Delta L_1, \Delta L_2, \dots \approx L/\text{step}$ values from specifications.

$N_1, N_2, \dots \approx$ settings of corresponding decades.

$$C = C_0 + M C_1$$

where $C_0 \approx 15\ \text{pF}$

$C_1 \approx 20\ \text{pF}$

M = number of unused decades (set to zero) preceding first decade used.

The phase angle (Q) for this circuit is:

$$Q \approx \omega(L/R - RC).$$

At low values of R, the L/R term is dominant; at high values of R, the RC term is more important.

The effective series resistance is:

$$R_s = \frac{R}{1 + \omega^2 R^2 C^2}$$

The effective parallel resistance is:

$$R_p = R \left(1 + \frac{\omega^2 L^2}{R^2} \right)$$

At low values, the series resistance remains constant to rather high frequencies because inductance has no effect on R_s . At very low values, skin effect increases R_s .

At high values, the series resistance falls off rather rapidly with frequency because of capacitance. The parallel resistance, however, is not affected by the lumped capacitance shown in the simple equivalent circuit (see Figure 3-1). The parallel value is affected by distributed capacitance and dielectric loss not shown. An approximate equation that considers these effects on R_p is:

$$R_p \approx R \left[1 + \frac{\omega^2 L^2}{R^2} - \omega R 10^{-3} - 4\omega^2 R^2 10^{-24} - 25\omega^2 R R_y 10^{-24} \right]$$

The $\omega R 10^{-3}$ term represents dielectric loss, the next term represents distributed capacitance in the first decade used (not zero), and the last term represents distributed capacitance in the first decade if it is not used (set to zero), where R_y is the total possible value of that decade. (The last term is not used if the first decade is not set to zero). When the case is not tied to either terminal, the decade resistor becomes a three-terminal circuit as shown in Figure 3-3.

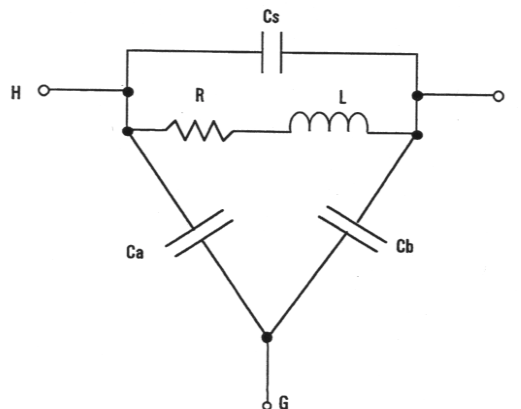

Figure 3-2. Equivalent three terminal circuit for a decade box with neither terminal tied to case

In Figure 3-2:

R = setting of the decade box.

$L = L_0 = N_1 \Delta L_1 + N_2 \Delta L_2 + \dots$

where $L_0 \approx 0.1 \mu\text{H}$ per decade \times number of decades in unit $+ 0.2 \mu\text{H}$.

$\Delta L_1, \Delta L_2, \dots \approx L/\text{step}$ values from specifications.

$N_1, N_2, \dots \approx$ settings of corresponding decades.

$C_a = 10 M_a + 8 \text{ pF}$

where $M_a =$ number of unused decades (set to zero) preceding first decade used.

$C_b = 20 M_b + 20 \text{ pF}$

where $M_b =$ number of unused decades (set to zero) preceding first decade used.

$C_s = 2 \text{ pF}$

There is also some distributed capacitance (C_d) from the resistor to the case, as shown in Figure 3-3. This capacitance has the effect of increasing the effective inductance by an amount of approximately $N^3R^2C \times 10^{-3}$: where N is the setting of the first used (not zero) decade, R is the total value of the decade resistor, and C is 2 pF.

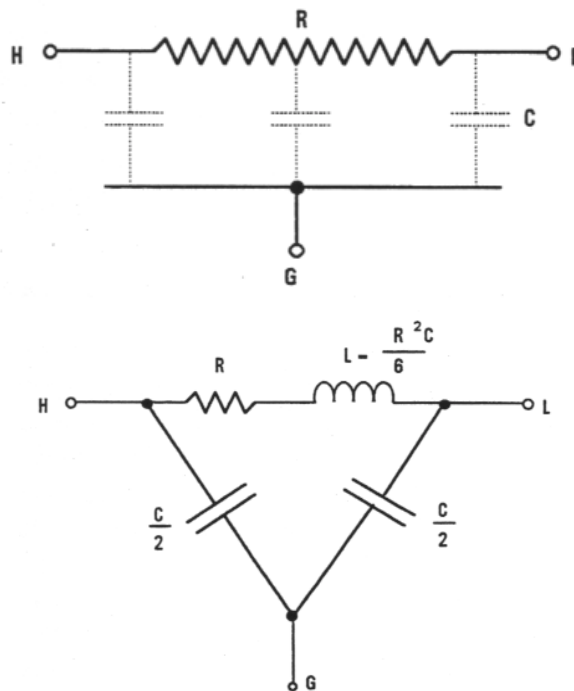

Figure 3-3. Approximation of distributed capacitance effects

Chapter 4 MAINTENANCE

4.1 Customer Service

The IET warranty attests to the quality of materials and workmanship in our products. For application assistance or if difficulties occur, our engineers will assist in any way possible. If you cannot eliminate the difficulty, please e-mail, FAX, or phone our Service Department, giving full information of the trouble and of steps taken to remedy it. Be sure to include the type and serial number of the instrument.

In the U. S. call
617-969-0804 for technical support
800-899-8438 or 516-334-5959 for customer service
516-334-5988 for FAX
www.ietlabs.com

4.2 Instrument Return

Before returning an instrument to IET for service please call our Service Department at 800-899-8438 for Return Material Authorization (RMA). Include a Purchase Order Number to insure expedient processing. Units under warranty will be repaired at no charge. For any questions on repair costs or shipment instructions, please contact our Service Department at the above number. To safeguard an instrument during shipment, please use packaging that is adequate to protect it from damage, (i.e., equivalent to the original packaging) and mark the box "Delicate Electronic Instrument". Return material should be sent freight prepaid to:

IET Labs, Inc.
10 Dedham Street
Newton, MA 02461

Attention: Service Department

