

CT7116

AC LEAKAGE CURRENT SENSOR

Instruction Manual

EN

Oct. 2016 Edition 1 Printed in Japan
CT7116A961-00 16-10H



HIOKI

HEADQUARTERS

81 Koizumi, Ueda, Nagano 386-1192, Japan
TEL +81-268-28-0562 FAX +81-268-28-0568
os-com@hioki.co.jp www.hioki.com
(International Sales Department)

1604EN

Edited and published by Hioki E.E. Corporation Printed in Japan
Please visit our website at www.hioki.com for the following:
• Regional contact information
• The latest revisions of instruction manuals and manuals in other languages.
• Declarations of Conformity for instruments that comply with CE mark requirements.

Warranty

Warranty malfunctions occurring under conditions of normal use in conformity with the Instruction Manual and Product Precautionary Markings will be repaired free of charge. This warranty is valid for a period of one (1) year from the date of purchase. Please contact the distributor from which you purchased the product for further information on warranty provisions.

Introduction

Thank you for purchasing the Hioki CT7116 AC Leakage Current Sensor. To obtain maximum performance from the device, please read this manual first, and keep it handy for future reference.

Be sure to also read the separate booklet "Current Sensor Operating Precautions" before use.

Overview

This current sensor has a Hioki PL14 output connector, enabling it to be automatically recognized when connected to a compatible instrument for simple setup. This device, which supports AC current measurement, has a rated current of 6 A. The device can be relied upon to measure subtle current with great accuracy due to the high-permeability material used for the jaws and magnetic shield.

Parts Names

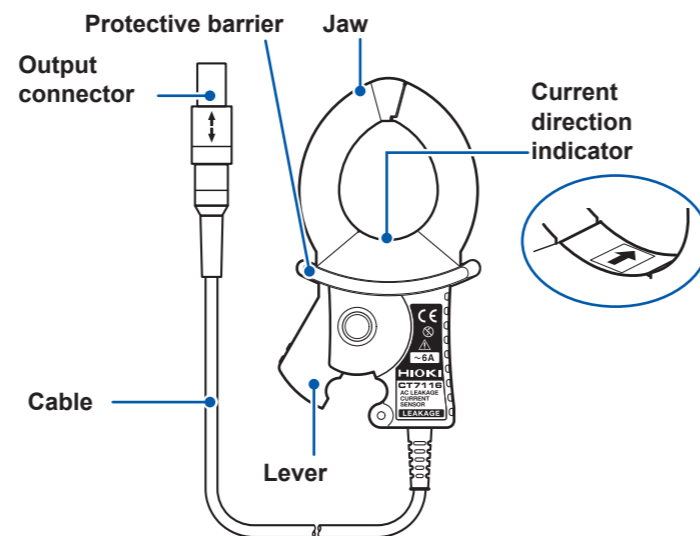

Measurement Procedure

Inspection Before Use

Verify that no damage occurred during storage or shipping. If you find any damage, contact your authorized Hioki distributor or reseller.

Check item	Remedy
Is the jaw cracked or damaged?	Discontinue use and contact your authorized Hioki distributor or reseller. If there is any damage, an electric shock may result.
Is the cable insulation torn?	Discontinue use and contact your authorized Hioki distributor or reseller. Broken connections will make proper measurement impossible.
Is the cable broken at the base of the connector or grip?	Discontinue use and contact your authorized Hioki distributor or reseller. Broken connections will make proper measurement impossible.

Procedure

1 Connect the device to the compatible instrument.

Compatible instrument

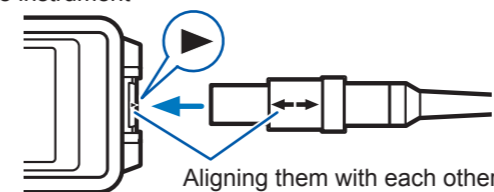

Aligning them with each other and insert the connector.

Align the arrow on the device's output connector with the mark ► on the compatible instrument's sensor input connector and insert the output connector.

2 Attach the clamp around the one or more conductors.

Squeeze the lever to open the jaw and attach the jaw around the conductors in a way that the conductors pass through the center of the jaw.

If the clamp is attached with the current direction indicator pointed in the opposite direction of currents, phases of measurement results will shift relative to measured currents by 180 degrees.

See "Load Current Measurement," "Leakage Current Measurement," or "Checking for Insulation Faults" for more details.

3 Verify that the jaw is fully closed.

Close the tips of the jaw completely before performing measurement. If the output cable is caught on the jaw or the jaw is forced into the measurement location, it may not close completely. If this occurs, it will not be possible to obtain an accurate measurement.

4 On completion of the measurement, detach the device from the conductors and unplug it from the instrument.

To unplug the device from the instrument, pull straight the cable out of the instrument, grasping the part with the arrow marked of the output connector.

Pulling strongly the base of the output cable could cause the device to be damaged.

To Extend the Cable

Use of only the optional Model L0220 series is allowed. The cable is extendable by up to 10 m. The device can operate under the following conditions: however, no performances of the device are guaranteed.

- Two or more extension cables are connected in series.
- The cable is extended by more than 10 m.

Load Current Measurement

IMPORTANT

- Attach the clamp around only one conductor. If you clamp single-phase (2-wire) or three-phase (3-wire) conductors together, the device will not be able to make a measurement.

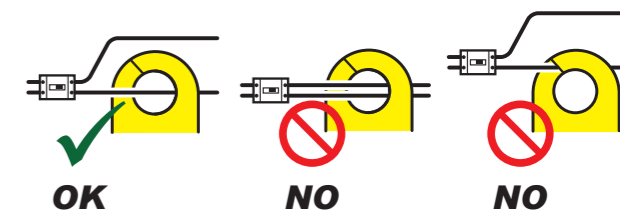

Attach the clamp around only one of the conductors in a way that it passes through the center of the clamp.

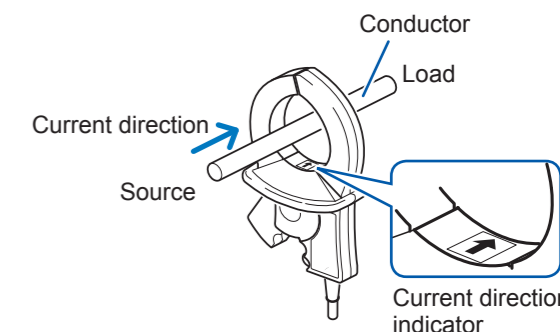

Leakage Current Measurement

Ground conductor measurement	Attach the clamp around only one of the conductors (as indicated by "1" in the figure below).
Bundle measurement	Attach the clamp the conductors in a bundle (as indicated by "2" in the figure below).

Single-phase three-wire system

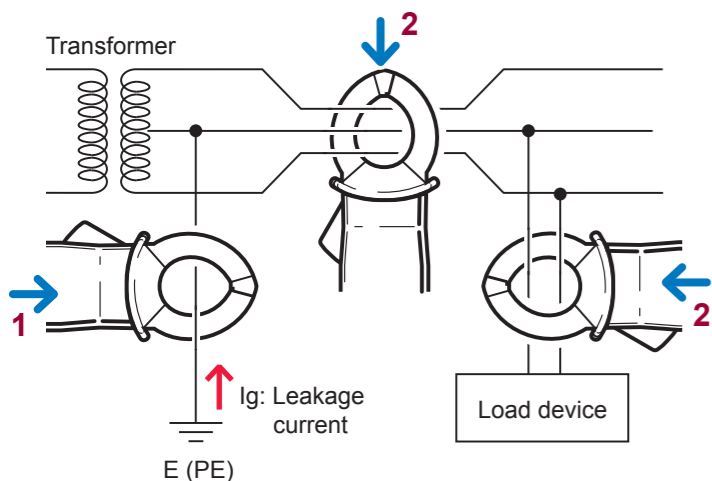

Three-phase three-wire system

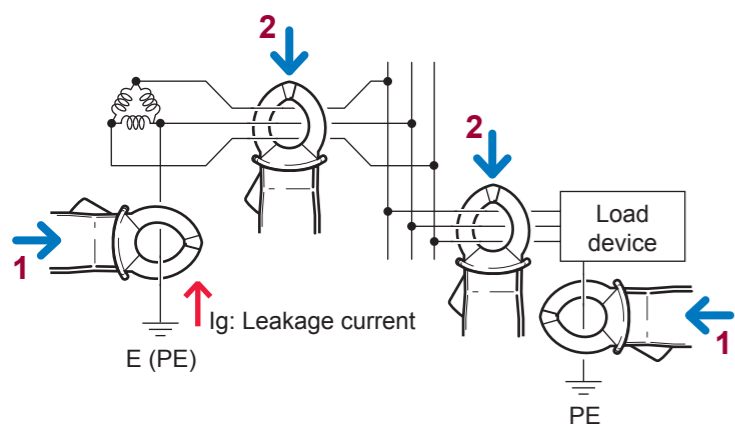

Single-phase two-wire system

Attach the clamp around the two conductors in a bundle.

Three-phase four-wire system

Attach the clamp around the four conductors in a bundle. If this is not possible, the measurement can also be carried out by attaching the clamp around the ground conductor of the equipment.

- If a strong current (on the order of 100 A) is flowing through an adjacent circuit, accurate measurement may not be possible. Perform the measurement at a sufficient distance from other current-carrying conductors.
- A current with special waveform such as one flowing through the secondary side of an inverter may not be measured correctly.

Checking for Insulation Faults

Measuring leakage currents flowing through each conductor in a circuit enables you to determine whether an earth leakage is present or not based on a variation in leakage currents.

It is useful to use a waveform recorder in combination with the device in order to check for an earth leakage that arises only when a specific installation is activated.

1 Attach the clamp around the ground conductor E (PE) of the transformer (as indicated "1" in the figure below).

2 If an earth leakage is determined to be present, look for a location of the insulation fault by performing the bundle measurement (attaching the clamp around conductors in a bundle), attaching it at a location closest to the source first, and then locations closer to the load in steps.

- See the figure below. If an insulation fault arises in the conductor at the location **A**, the leakage current can be detected by the bundle measurement performed at the location (1), but not at the location (2).
- If an insulation fault arises in the load device at the location **B**, the leakage current can be detected by performing the bundle measurement at the location (3), but not at the location (4).

Single-phase three-wire system

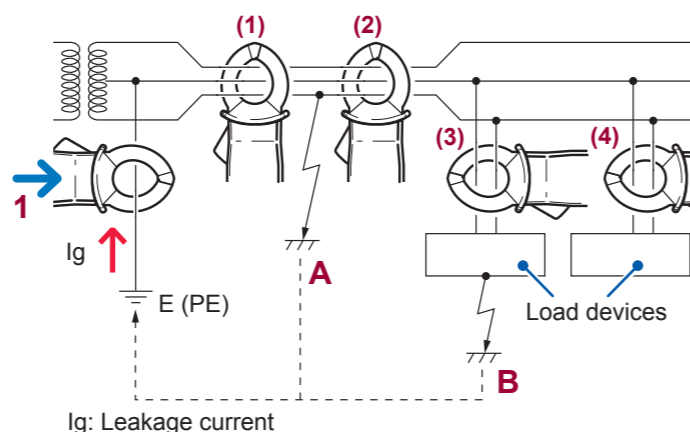

Specifications

General Specifications

Operating environment	Indoors, Pollution Degree 2, altitude up to 2000 m (6562 ft.)
Operating temperature and humidity	Temperature: -25°C to 65°C (-13°F to 149°F) Humidity: 80% RH or less (no condensation)
Storage temperature and humidity	Temperature: -25°C to 65°C (-13°F to 149°F) Humidity: 80% RH or less (no condensation)

Standards	Safety: EN61010 EMC: EN61326
Dust-proofness, water-proofness	IP40 (EN60529) (with sensor connected and jaw closed)
Power consumption category	Sensor power consumption category: 0
Dimensions	Approx. 74W × 145H × 42D mm (2.91"W × 5.71"H × 1.65"D) (excluding protrusions)
Mass	Approx. 340 g (12.0 oz.)
Cable length	Approx. 2500 mm (98.43")
Product warranty period	1 year
Accessories	Instruction Manual, Current Sensor Operating Precautions
Options	Model L0220-01 Extension Cable (2 m) Model L0220-02 Extension Cable (5 m) Model L0220-03 Extension Cable (10 m)

Output Specifications / Measurement Specifications

(1) Basic Specifications

Output connector	Hioki PL14
Rated measured current	6 AAC
Output rate	100 mV AC/A
Maximum measured current	RMS value, continuous input: 10 A (within the frequency derating curve stated below) However, 30 kA/Hz at a frequency of 1 kHz or higher Peak value (under the RMS value conditions described above): 30 A peak
Frequency range	40 Hz to 5 kHz
Measurable conductor diameter	φ40 mm or less (insulated conductor)

Frequency derating curve

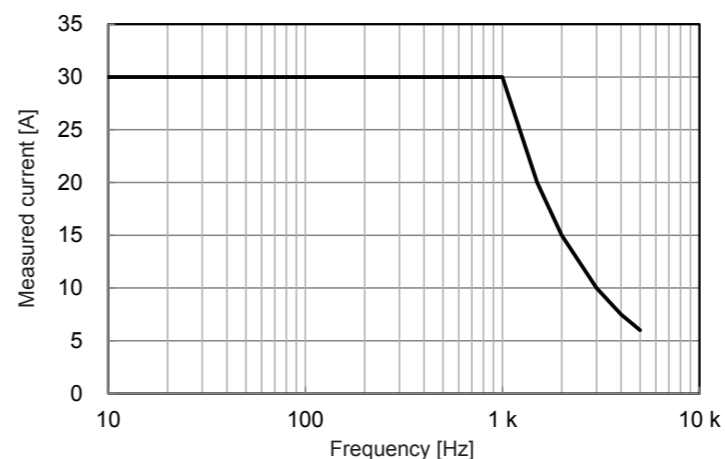

(2) Accuracy Specifications

f.s.: The rated measurement current

rdg.: The value currently being measured and indicated on the measuring instrument

Conditions of guaranteed accuracy	Guaranteed accuracy period:	1 year
	Guaranteed accuracy period from adjustment made by Hioki:	1 year
	Opening and closing of the jaw:	10 000 times or less
	Accuracy guarantee for temperature and humidity:	23°C±5°C (73.4°F±9°F), 80% RH or less
	• Sine wave input	
	• Equal to or less than the rated current but within the derating curve	
	• Conductors passing through the center of the jaw	
	• Not including any effects	
Amplitude accuracy	±1.0% rdg. ±0.05% f.s. (45 Hz to 66 Hz) ±3.0% rdg. ±0.1% f.s. (other than the frequency range between 45 Hz and 66 Hz but within the frequency range)	
Phase accuracy	±3° or less: 45 Hz to 66 Hz (with a measured current of 1 A or more input)	
Temperature coefficient	Add {0.05 × (accuracy spec.)/°C} when operated within the operating temperature range (other than 23°C±5°C)	
Effect of conductor position (deviation from center)	±0.1% or less	
Effect of external magnetic field (400 A/m, 50 Hz / 60 Hz)	Corresponding to 5 mA, 7.5 mA at a maximum	
Residual current characteristics	5 mA or less (for a pair of electric conductors carrying a current of 100 A each flowing in opposite direction of each other)	
Maximum extendable length	10 m (However, depending on instrument to which device is connected)	