

Raising the Bar for High-Accuracy Measurement

Attain greater accuracy when measuring the efficiency of increasingly high-current, high-speed EV/HEV inverters

Dramatically improved frequency characteristics and anti-noise performance

CT6875

500 A AC/DC

DC to 2 MHz

DC to 100 kHz
Earlier model (9709)

CT6876

1000 A AC/DC

DC to 1.5 MHz

DC to 20 kHz
Earlier model (CT6865)

CT6877

2000 A AC/DC

DC to 300 kHz

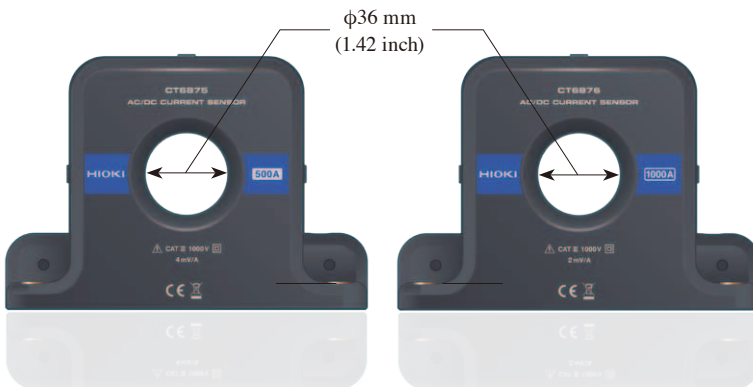

Example measurement setup with Power Analyzer PW6001

POWER ANALYZER PW6001

Improve Power Conversion Efficiency

From DC to 2 MHz, industry's proven solution for high-accuracy power analysis.

The PW6001 features a phase shift function for current sensors to lock in accurate measurement of high-frequency power. 5 MS/s sampling at 18-bit resolution ensure true power analysis of PWM waveforms and results that are free of aliasing error.

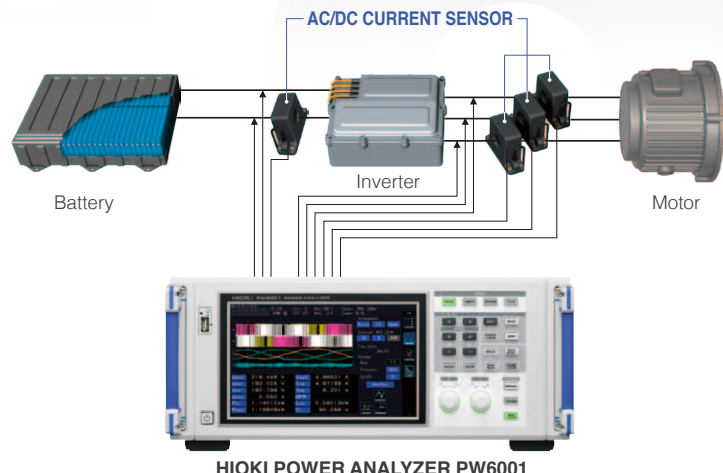

HIOKI POWER ANALYZER PW6001

Evaluate inverter power conversion efficiency



Unparalleled technology driving the evolution of current measurement

Broadband Flux Gate Zero-Flux Method Sensor with New Opposed Split Coil*

Current sensor performance is maximized with the "Zero Flux (Fluxgate Detection)" measurement method. High frequency current is detected with windings (CT method), and direct to low frequency current is detected with fluxgates. Use of a newly developed opposed split coil* for the winding (CT) makes possible a broad measurement band, while strengthened shielding boosts anti-noise performance.

*Opposed Split Coil: Coil in which divided windings are arranged opposite each other on a magnetic core to broaden the range of current detection

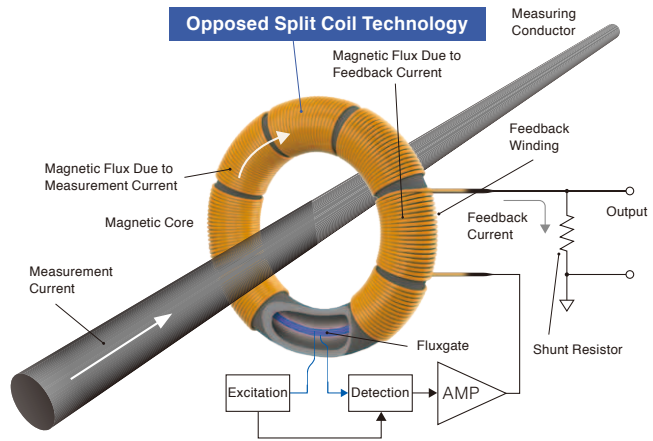

Toward even higher-accuracy measurement... the key is flat frequency characteristics and CMRR performance.

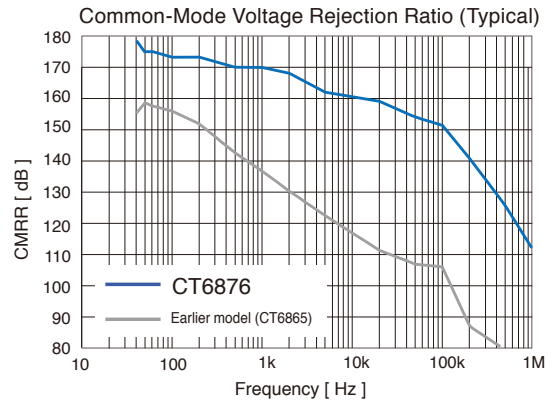
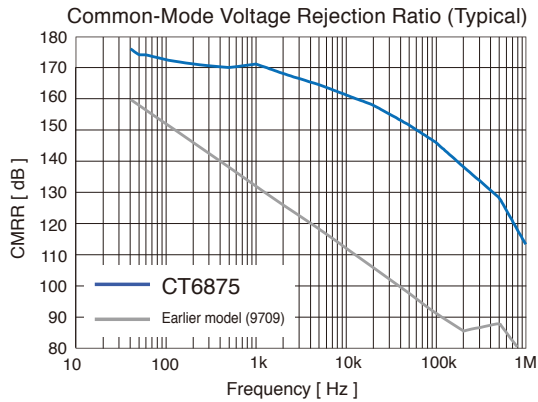
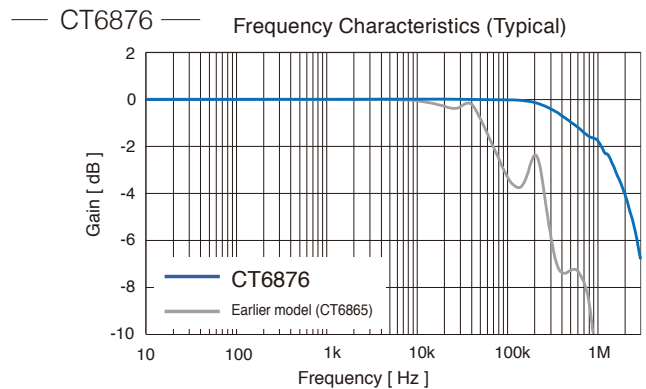
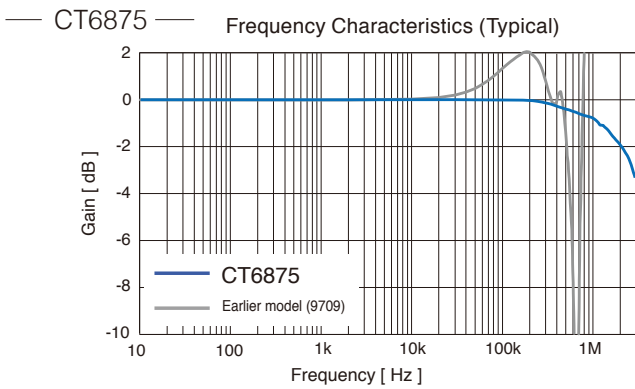

Excellent noise resistance

Improved noise resistance allows accurate measurement of switching current that until now would have been obscured by noise.

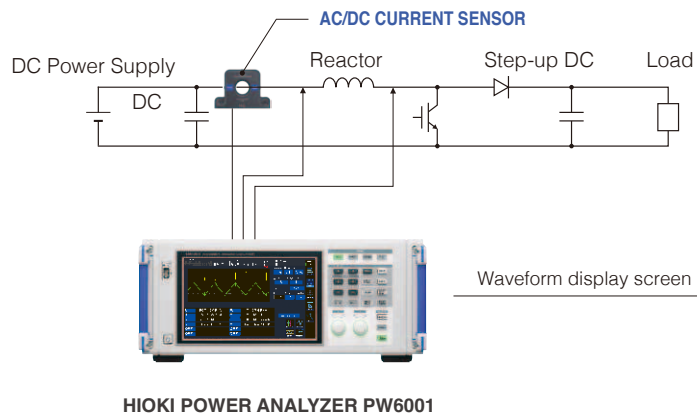

Comparison of measurement waveforms, CT6875 and Earlier model

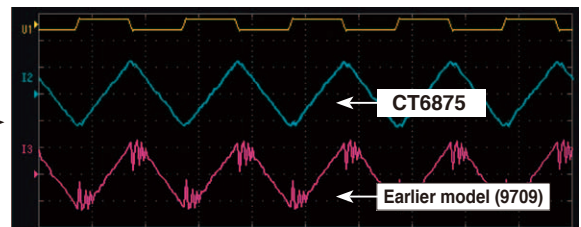

Comparison of measurement waveforms, CT6876 and Earlier model

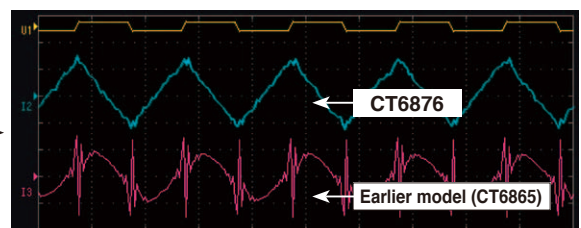

Example of Measured Waveforms for Switching Current at 100kHz (Measured with HIOKI PW6001)

CT6875, CT6875-01



AC/DC 500 A

Frequency band:
DC to 2 MHz (± 3 dB Typical)*

*CT6875-01: DC to 1.5 MHz (± 3 dB Typical)

Diameter of measurable conductors:
 ϕ 36 mm (1.42 in) or less
Output connector: ME15W
Cable length: CT6875 3 m (9.84 ft)
CT6875-01 10 m (32.81 ft)

Specifications

Accuracy (Accuracy guaranteed for 1 year, Post-adjustment accuracy guaranteed for 1 year)

Frequency	Amplitude	Phase
DC	$\pm 0.04\%$ rdg. $\pm 0.008\%$ f.s.	-
DC < f < 16 Hz	$\pm 0.1\%$ rdg. $\pm 0.02\%$ f.s.	$\pm 0.1^\circ$
16 Hz \leq f \leq 45 Hz	$\pm 0.05\%$ rdg. $\pm 0.01\%$ f.s.	$\pm 0.1^\circ$
45 Hz < f \leq 66 Hz	$\pm 0.04\%$ rdg. $\pm 0.008\%$ f.s.	$\pm 0.1^\circ$
66 Hz < f \leq 100 Hz	$\pm 0.05\%$ rdg. $\pm 0.01\%$ f.s.	$\pm 0.1^\circ$
100 Hz < f \leq 500 Hz	$\pm 0.1\%$ rdg. $\pm 0.02\%$ f.s.	$\pm 0.2^\circ$
500 Hz < f \leq 1 kHz	$\pm 0.2\%$ rdg. $\pm 0.02\%$ f.s.	$\pm 0.4^\circ$
1 kHz < f \leq 5 kHz	$\pm 0.4\%$ rdg. $\pm 0.02\%$ f.s.	$\pm 0.5^\circ$
5 kHz < f \leq 10 kHz	$\pm 0.4\%$ rdg. $\pm 0.02\%$ f.s.	$\pm(0.1 \times f \text{ kHz})^\circ$
10 kHz < f \leq 50 kHz	$\pm 1.5\%$ rdg. $\pm 0.05\%$ f.s.	$\pm(0.1 \times f \text{ kHz})^\circ$
50 kHz < f \leq 100 kHz	$\pm 2.5\%$ rdg. $\pm 0.05\%$ f.s.	$\pm(0.1 \times f \text{ kHz})^\circ$
100 kHz < f \leq 1 MHz	$\pm(0.025 \times f \text{ kHz})\%$ rdg. $\pm 0.05\%$ f.s.	$\pm(0.1 \times f \text{ kHz})^\circ$
Frequency band	2 MHz (± 3 dB Typical)	-

- With sine wave input and centrally positioned conductor; does not reflect various effects.
- When connected to instrument with an input resistance of at least 1 M Ω .
- Amplitude accuracy and phase accuracy are defined for input of 110% f.s. or less that falls within the derating range.
- Values provided for frequencies of DC < f < 10 Hz are design values.
- Add $\pm 0.01\%$ rdg. to the amplitude accuracy for input from 100% f.s. to 110% f.s.
- For the CT6875-01, add the following for frequencies of 1 kHz < f \leq 1 MHz:
- Amplitude accuracy: $\pm(0.005 \times f \text{ kHz})\%$ rdg. Phase accuracy: $\pm(0.015 \times f \text{ kHz})^\circ$

Temperature and humidity range for guaranteed accuracy	0°C to 40°C (32°F to 104°F), 80% RH or less
Effect of temperature	In ranges from -40°C to 0°C (-40°F to 32°F) and 40°C to 85°C (104°F to 185°F) Amplitude sensitivity: ± 20 ppm of rdg./ °C Offset voltage: ± 5 ppm of f.s./ °C
Magnetic susceptibility	10 mA or less (Scaled value, after input of 500 A DC)
Common-mode voltage rejection ratio (CMRR)	140 dB or greater (50 Hz/60 Hz), 120 dB or greater (100 kHz) (Effect on output voltage/common-mode voltage)
Effect of conductor position	DC, 50 Hz/60 Hz: $\pm 0.01\%$ rdg. or less (100 A input) 10 kHz: $\pm 0.4\%$ rdg. or less (10 A input) 100 kHz: $\pm 2.5\%$ rdg. or less (10 A input) With a wire diameter of 10 mm
Effect of external magnetic field	20 mA or less (Scaled value, in a DC and 60 Hz magnetic field of 400 A/m)
Maximum input current	Within the derating range Maximum input of up to ± 1500 A peak (design value) allowed at 40°C or less for 20 ms or less
Output voltage	4 mV/A
Offset voltage	± 15 ppm Typical (23°C)
Linearity	± 5 ppm Typical (23°C, no input)
Output impedance	50 Ω ± 10 Ω
Operating temperature and humidity range	-40°C to 85°C, 80% RH or less (no condensation)
Storage temperature and humidity range	-40°C to 85°C, 80% RH or less (no condensation)
Power supply	Power supplied from PW6001, PW3390, CT9555, CT9556, CT9557, or external DC power supply
Dimensions	Approx. 160 mm (6.30 in) W \times 112 mm (4.41 in) H \times 50 mm (1.97 in) D
Mass	Approx. CT6875: 0.8 kg (28.2 oz), CT6875-01: 1.10 kg (38.8 oz)
Accessories	User Guide, marker bands, and operating precautions (0990A907)

Frequency derating

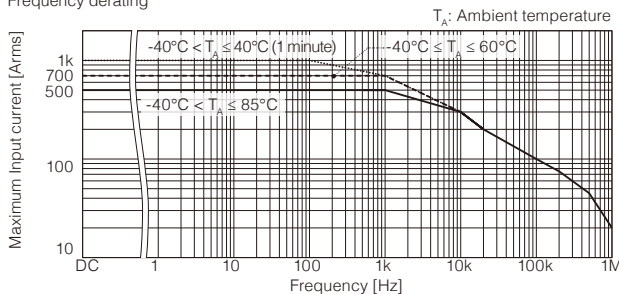

POWER ANALYZER PW6001: Combined Accuracy

Frequency	Current	Power	Phase
DC	$\pm 0.06\%$ rdg. $\pm 0.038\%$ f.s. (f.s.=PW6001 Range)	$\pm 0.06\%$ rdg. $\pm 0.058\%$ f.s. (f.s.=PW6001 Range)	PW6001 accuracy + sensor accuracy
45 Hz \leq f \leq 66 Hz	$\pm 0.06\%$ rdg. $\pm 0.028\%$ f.s. (f.s.=PW6001 Range)	$\pm 0.06\%$ rdg. $\pm 0.038\%$ f.s. (f.s.=PW6001 Range)	
Bandwidths other than 45 Hz \leq f \leq 65 Hz and DC	PW6001 accuracy + sensor accuracy (Consider sensor rating when calculating f.s. error.)	PW6001 accuracy + sensor accuracy (Consider sensor rating when calculating f.s. error.)	

For other measurement parameters, add the PW6001 accuracy and the sensor accuracy (and consider the sensor rating when calculating the f.s. error).

CT6876, CT6876-01



AC/DC 1000 A

Frequency band:
DC to 1.5 MHz (± 3 dB Typical)*

*CT6876-01: DC to 1.2 MHz (± 3 dB Typical)

Diameter of measurable conductors:
 ϕ 36 mm (1.42 in) or less
Output connector: ME15W
Cable length: CT6876 3 m (9.84 ft)
CT6876-01 10 m (32.81 ft)

Specifications

Accuracy (Accuracy guaranteed for 1 year, Post-adjustment accuracy guaranteed for 1 year)

Frequency	Amplitude	Phase
DC	$\pm 0.04\%$ rdg. $\pm 0.008\%$ f.s.	-
DC < f < 16 Hz	$\pm 0.1\%$ rdg. $\pm 0.02\%$ f.s.	$\pm 0.1^\circ$
16 Hz \leq f \leq 45 Hz	$\pm 0.05\%$ rdg. $\pm 0.01\%$ f.s.	$\pm 0.1^\circ$
45 Hz < f \leq 66 Hz	$\pm 0.04\%$ rdg. $\pm 0.008\%$ f.s.	$\pm 0.1^\circ$
66 Hz < f \leq 100 Hz	$\pm 0.05\%$ rdg. $\pm 0.01\%$ f.s.	$\pm 0.1^\circ$
100 Hz < f \leq 500 Hz	$\pm 0.1\%$ rdg. $\pm 0.02\%$ f.s.	$\pm 0.2^\circ$
500 Hz < f \leq 1 kHz	$\pm 0.2\%$ rdg. $\pm 0.02\%$ f.s.	$\pm 0.4^\circ$
1 kHz < f \leq 5 kHz	$\pm 0.5\%$ rdg. $\pm 0.02\%$ f.s.	$\pm 0.5^\circ$
5 kHz < f \leq 10 kHz	$\pm 0.5\%$ rdg. $\pm 0.02\%$ f.s.	$\pm(0.1 \times f \text{ kHz})^\circ$
10 kHz < f \leq 50 kHz	$\pm 2\%$ rdg. $\pm 0.05\%$ f.s.	$\pm(0.1 \times f \text{ kHz})^\circ$
50 kHz < f \leq 100 kHz	$\pm 3\%$ rdg. $\pm 0.05\%$ f.s.	$\pm(0.1 \times f \text{ kHz})^\circ$
100 kHz < f \leq 1 MHz	$\pm(0.03 \times f \text{ kHz})\%$ rdg. $\pm 0.05\%$ f.s.	$\pm(0.1 \times f \text{ kHz})^\circ$
Frequency band	1.5 MHz (± 3 dB Typical)	-

- With sine wave input and centrally positioned conductor; does not reflect various effects.
- When connected to instrument with an input resistance of at least 1 M Ω .
- Amplitude accuracy and phase accuracy are defined for input of 110% f.s. or less that falls within the derating range.
- Values provided for frequencies of DC < f < 10 Hz are design values.
- Add $\pm 0.01\%$ rdg. to the amplitude accuracy for input from 100% f.s. to 110% f.s.
- For the CT6876-01, add the following for frequencies of 1 kHz < f \leq 1 MHz:
- Amplitude accuracy: $\pm(0.005 \times f \text{ kHz})\%$ rdg. Phase accuracy: $\pm(0.015 \times f \text{ kHz})^\circ$

Temperature and humidity range for guaranteed accuracy	0°C to 40°C (32°F to 104°F), 80% RH or less
Effect of temperature	In ranges from -40°C to 0°C (-40°F to 32°F) and 40°C to 85°C (104°F to 185°F) Amplitude sensitivity: ± 20 ppm of rdg./ °C Offset voltage: ± 5 ppm of f.s./ °C
Magnetic susceptibility	20 mA or less (Scaled value, after input of 1000 A DC)
Common-mode voltage rejection ratio (CMRR)	140 dB or greater (50 Hz/60 Hz), 120 dB or greater (100 kHz) (Effect on output voltage/common-mode voltage)
Effect of conductor position	DC, 50 Hz/60 Hz: $\pm 0.01\%$ rdg. or less (100 A input) 10 kHz: $\pm 0.5\%$ rdg. or less (10 A input) 100 kHz: $\pm 3\%$ rdg. or less (10 A input) With a wire diameter of 10 mm
Effect of external magnetic field	40 mA or less (Scaled value, in a DC and 60 Hz magnetic field of 400 A/m)
Maximum input current	Within the derating range Maximum input of up to ± 1800 A peak (design value) allowed at 40°C or less for 20 ms or less
Output voltage	2 mV/A
Output impedance	50 Ω ± 10 Ω
Offset voltage	± 15 ppm Typical (23°C)
Linearity	± 5 ppm Typical (23°C, no input)
Operating temperature and humidity range	-40°C to 85°C, 80% RH or less (no condensation)
Storage temperature and humidity range	-40°C to 85°C, 80% RH or less (no condensation)
Power supply	Power supplied from PW6001, PW3390, CT9555, CT9556, CT9557, or external DC power supply
Dimensions	Approx. 160 mm (6.30 in) W \times 112 mm (4.41 in) H \times 50 mm (1.97 in) D
Mass	Approx. CT6876: 0.95 kg (33.5 oz), CT6876-01: 1.25 kg (44.1 oz)
Accessories	User Guide, marker bands, and operating precautions (0990A907)

Frequency derating

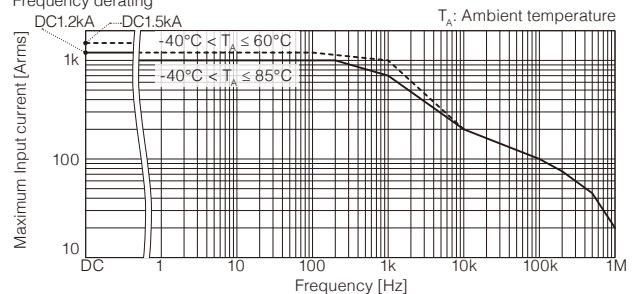

POWER ANALYZER PW3390: Combined Accuracy

Frequency	Current	Power	Phase
DC	$\pm 0.09\%$ rdg. $\pm 0.078\%$ f.s. (f.s.=PW3390 Range)	$\pm 0.09\%$ rdg. $\pm 0.078\%$ f.s. (f.s.=PW3390 Range)	PW3390 accuracy + sensor accuracy
45 Hz \leq f \leq 66 Hz	$\pm 0.08\%$ rdg. $\pm 0.058\%$ f.s. (f.s.=PW3390 Range)	$\pm 0.08\%$ rdg. $\pm 0.058\%$ f.s. (f.s.=PW3390 Range)	
Bandwidths other than 45 Hz \leq f \leq 65 Hz and DC	PW3390 accuracy + sensor accuracy (Consider sensor rating when calculating f.s. error.)	PW3390 accuracy + sensor accuracy (Consider sensor rating when calculating f.s. error.)	

For other measurement parameters, add the PW3390 accuracy and the sensor accuracy (and consider the sensor rating when calculating the f.s. error).

Delivering both high-current measurement and broadband performance

Rated primary current

2000 A

Measurement Frequency Range

300 kHz

Accuracy

±0.04% rdg. (±0.008% f.s.)

AC/DC CURRENT SENSOR

CT6877



Available Spring 2019

Specifications

(Accuracy guaranteed for 1 year, Post-adjustment accuracy guaranteed for 1 year)

	CT6877
Rated primary current	2000 A AC/DC
Maximum input current	±3200 A peak
Output voltage	1 mV/A
Basic accuracy (DC, 45 Hz ≤ f ≤ 66 Hz)	Amplitude: ±0.04% rdg. ±0.008% f.s. Phase: ±0.1°
Frequency band	DC to 300 kHz
Operating temperature and humidity range	-40°C to +85°C (-40°F to 185°F), 80% RH or less
Diameter of measurable conductors	φ80 mm (3.15 in) or less
Interface	Dedicated interface (ME15W)
Power supply	Power supplied from Power Analyzer PW6001/PW3390 or Sensor Unit CT9555/CT9556/CT9557
Dimensions (excluding protrusions and cables)	Approx. 286 mm (11.26 in) W × 296 mm (11.65 in) H × 126 mm (4.96 in) D

Example measurement setup with Power Analyzer PW6001

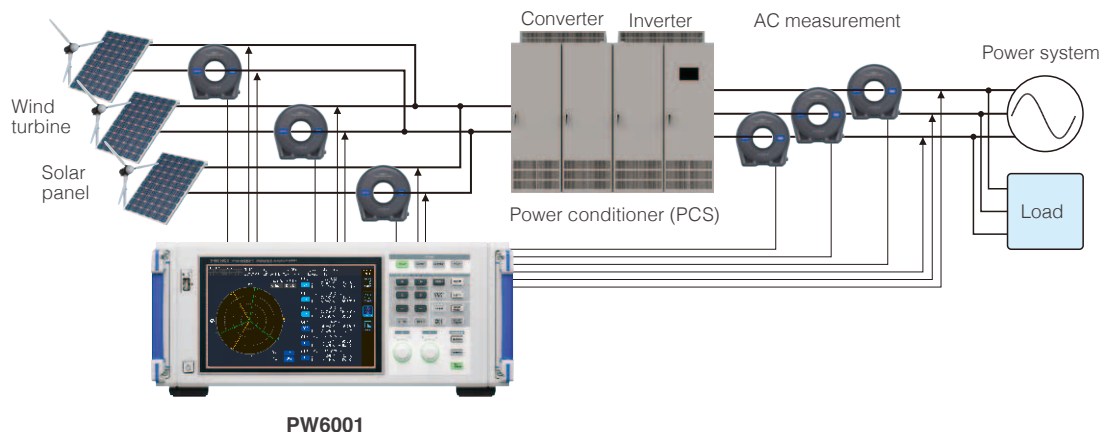

PV/Wind turbine Power Conditioner (PCS) Efficiency Measurement

Model: AC/DC CURRENT SENSOR CT6875, CT6876, CT6877

Model No. (Order Code)	Rated current	Output cable length
CT6875	500 A	3 m (9.84 ft)
CT6875-01	500 A	10 m (32.81 ft)
CT6876	1000 A	3 m (9.84 ft)
CT6876-01	1000 A	10 m (32.81 ft)
CT6877	2000 A	3 m (9.84 ft)
CT6877-01	2000 A	10 m (32.81 ft)

Available Spring 2019

Available Spring 2019

Options

CONVERSION CABLE CT9901



Converts the sensor's ME15W output cable terminal to PL23

EXTENSION CABLE CT9902



Cable length: 5 m

Extends sensor's output cable 5 m (16.41 ft); combine for maximum additional length of 10 m (32.81 ft).

Note: Company names and Product names appearing in this catalog are trademarks or registered trademarks of various companies.

HIOKI

HIOKI E. E. CORPORATION

HEADQUARTERS

81 Koizumi
Ueda, Nagano 386-1192 Japan
www.hioki.com

HIOKI USA CORPORATION

TEL +1-609-409-9109 FAX +1-609-409-9108
hioki@hiokiusa.com / www.hiokiusa.com

HIOKI (Shanghai) SALES & TRADING CO., LTD.
TEL +86-21-6391-0090/0092 FAX +86-21-6391-0360
info@hioki.com.cn / www.hioki.cn

HIOKI SINGAPORE PTE. LTD.
TEL +65-6634-7677 FAX +65-6634-7477
info-sg@hioki.com.sg / www.hioki.com.sg

HIOKI KOREA CO., LTD.
TEL +82-2-2183-8847 FAX +82-2-2183-3360
info-kr@hioki.co.jp / www.hiokikorea.com

HIOKI EUROPE GmbH
TEL +49-6173-31856-0 FAX +49-6173-31856-25
hioki@hioki.eu / www.hioki.com

HIOKI TAIWAN CO., LTD.
TEL +886-3-3467160 FAX +886-3-3467162
info-tw@hioki.com.tw / www.hioki.com

DISTRIBUTED BY