

8672S SYNTHESIZED SIGNAL GENERATOR SYSTEM and 86720A FREQUENCY EXTENSION UNIT

SERIAL NUMBERS

This manual applies directly to Model 86720A Frequency Extension Units with serial numbers prefixed 2325A and to all 8672S Synthesized Signal Generator Systems using these Frequency Extension Units.

For additional important information about serial numbers, see INSTRUMENTS COVERED BY MANUAL in Section I.

8672A-K22

Appendix A contains the necessary backdating information to use this manual with all Model 8672A-K22 Frequency Extension Units.



**HEWLETT
PACKARD**

© Copyright HEWLETT-PACKARD COMPANY 1983
1501 PAGE MILL ROAD, PALO ALTO, CALIFORNIA, U.S.A.

MANUAL PART NUMBER. 86720-90001
Microfiche Part No. 86720-90002

Printed: AUGUST 1983

CERTIFICATION

Hewlett-Packard Company certifies that this product met its published specifications at the time of shipment from the factory. Hewlett-Packard further certifies that its calibration measurements are traceable to the United States National Bureau of Standards, to the extent allowed by the Bureau's calibration facility, and to the calibration facilities of other International Standards Organization members.

WARRANTY

This Hewlett-Packard instrument product is warranted against defects in material and workmanship for a period of one year from date of shipment. During the warranty period, Hewlett-Packard Company will, at its option, either repair or replace products which prove to be defective.

For warranty service or repair, this product must be returned to a service facility designated by HP. Buyer shall prepay shipping charges to HP and HP shall pay shipping charges to return the product to Buyer. However, Buyer shall pay all shipping charges, duties, and taxes for products returned to HP from another country.

HP warrants that its software and firmware designated by HP for use with an instrument will execute its programming instructions when properly installed on that instrument. HP does not warrant that the operation of the instrument, or software, or firmware will be uninterrupted or error free.

LIMITATION OF WARRANTY

The foregoing warranty shall not apply to defects resulting from improper or inadequate maintenance by Buyer, Buyer-supplied software or interfacing, unauthorized modification or misuse, operation outside of the environmental specifications for the product, or improper site preparation or maintenance.

NO OTHER WARRANTY IS EXPRESSED OR IMPLIED. HP SPECIFICALLY DISCLAIMS THE IMPLIED WARRANTIES OF MERCHANTABILITY AND FITNESS FOR A PARTICULAR PURPOSE.

EXCLUSIVE REMEDIES

THE REMEDIES PROVIDED HEREIN ARE BUYER'S SOLE AND EXCLUSIVE REMEDIES. HP SHALL NOT BE LIABLE FOR ANY DIRECT, INDIRECT, SPECIAL, INCIDENTAL, OR CONSEQUENTIAL DAMAGES, WHETHER BASED ON CONTRACT, TORT, OR ANY OTHER LEGAL THEORY.

ASSISTANCE

Product maintenance agreements and other customer assistance agreements are available for Hewlett-Packard products.

For any assistance, contact your nearest Hewlett-Packard Sales and Service Office. Addresses are provided at the back of this manual.

CONTENTS

	Page		Page
Section I			
GENERAL INFORMATION			
Introduction	1-1	Turn-on Procedure	3-1
Specifications	1-1	Signal Generator System Local Operation	3-2
Safety Considerations	1-1	Low Band Frequency Range Operation	3-2
Instruments Covered by Manual	1-1	High Band Frequency Range Operation	3-2
Manual Changes Supplement	1-1	FEU Local Operation	3-3
Description	1-4	Panel Features	3-3
Low Band and High Band	1-4	FEU Operator's Local Check	3-3
HP-IB Operation	1-4	Remote Operation	3-3
HP 8672S Signal Generator System Options	1-4	Signal Generator System Remote Operation	3-3
Signal Generator System Electrical Options	1-4	Programming Quick Reference Guides	3-3
Signal Generator System Mechanical		Programming Example and Tips	3-7
Options	1-5	FEU Remote Operation	3-7
HP 8672A Synthesized Signal Generator		HP-IB Compatibility	3-11
Options	1-5	Remote Mode	3-11
HP 86720A Frequency Extension Unit		Local Mode	3-11
Options	1-5	Addressing	3-11
Hewlett-Packard Interface Bus (HP-IB)	1-5	Data Messages	3-11
Compatibility	1-5	Receiving the Data Message	3-11
Selecting the HP-IB Address	1-6	Sending the Data Message	3-11
Accessories Supplied	1-6	Receiving the Trigger Message	3-11
Equipment Required But Not Supplied	1-6	Receiving the Clear Message	3-11
Equipment Available	1-6	Receiving the Remote Message	3-12
Recommended Test Equipment	1-6	Receiving the Local Message	3-12
		Receiving the Local Lockout Message	3-12
		Receiving the Clear Lockout/Set Local	
		Message	3-12
		Receiving the Pass Control Message	3-12
		Sending the Require Service Message	3-12
		Sending the Status Byte Message	3-12
		Sending the Status Bit Message	3-12
		Receiving the Abort Message	3-12
		Signal Generator System Operator's	
		Checks	3-12
		Signal Generator System Local Operator's	
		Checks	3-12
		Signal Generator System Remote Operator's	
		Checks	3-12
		Operator Maintenance	3-12
Section II			
INSTALLATION			
Introduction	2-1		
Initial Inspection	2-1		
Preparation For Use	2-1		
Power Requirement	2-1		
Line Voltage and Fuse Selection	2-1		
Power Cable	2-2		
HP-IB Address Selection	2-2		
Interconnection	2-2		
Mating Connectors	2-2		
Operating Environment	2-2		
Bench Operation	2-2		
Rack Mounting	2-2		
Accessories Supplied	2-2		
Connecting the Frequency Extension Unit to			
the Signal Generator	2-2		
Storage and Shipment	2-4		
Environment	2-4		
Packaging	2-4		
Section III			
OPERATION			
Introduction	3-1		
Local Operation	3-1		
		Section IV	
		PERFORMANCE TESTS	
		Introduction	4-1
		Equipment Required	4-1
		Test Record	4-1
		Calibration Cycle	4-1
		Abbreviated Performance Testing	4-1
		Summary of Performance Tests	4-1
		Signal Generator System Operational	
		Verification Test	4-4
		Frequency Range and Resolution Tests	4-6
		On/Off Ratio Test	4-8
		Pulse Performance Test	4-9



CONTENTS (cont'd)

	Page		Page
Section V ADJUSTMENTS		Section VIII SERVICE	
Introduction	5-1	Introduction	8-1
Safety Considerations	5-1	Service Sheets	8-1
Equipment Required	5-1	Block Diagrams	8-1
Factory Selected Components	5-1	Circuit Diagrams	8-1
Related Adjustments	5-1	Safety Considerations	8-1
Low Band Adjustments (10 MHz to 2 GHz)	5-2	Before Applying Power	8-1
Offset Adjustment	5-6	Warnings and Cautions	8-1
Rise And Fall Time Adjustment	5-7	Recommended Test Equipment and	
		Accessories	8-10
		Service Tools, Aids and Information	8-10
		Support Kit	8-10
		Parts and Cable Locations	8-10
		Pozidriv Screwdrivers	8-10
		Blade Tuning Tools	8-10
		Servicing Aids on Printed Circuits	8-10
		Non-Field Repairable Assemblies	8-10
		After Service Product Safety Checks	8-10
		Troubleshooting	8-11
		General	8-11
Section VI REPLACEABLE PARTS		Appendix A MANUAL CHANGES REQUIRED FOR USE WITH HP 8672A-K22 FEU	
Introduction	6-1	Introduction	A-1
Abbreviations	6-1	Manual Changes	A-1
Replaceable Parts List	6-1		
Ordering Instruction	6-1		
Recommended Spares List	6-1		
Section VII MANUAL CHANGES			
Introduction	7-1		

SERVICE SHEETS

	Page		Page
1 Analog and Pulse Modulator Circuits		7 ALC Amplifier (CW and Pulse)	8-29
Block Diagram	8-17	8 HP-IB Handshake and Data Input	
2 HP-IB and Front Panel Circuits		Circuits	8-31
Block Diagram	8-19	9 Remote/Local Logic Circuits	8-33
3 RF Paths (Standard, Option 004 and		10 Latch Circuits	8-35
Option 005)	8-21	11 Driver Circuits	8-37
4 RF Paths (Options 009 and 010)	8-23	12 Main Power Supply Circuits	8-39
5 Pulse Driver Circuits	8-25	13 Pulse Driver Power Supply Circuits	8-41
6 ALC Amplifier (CW)	8-27	14 ALC Power Supply Circuits	8-43

LIST OF ILLUSTRATIONS

Figure	Page	Figure	Page
1-1. HP 8672S Synthesized Signal Generator	1-0	8-7. Pulse Input (A1TP9, 5V per division) vs. Waveform at A1TP2 (5V per division). Horizontal scale: 1 μ s per division	8-24
1-2. HP 86720A Frequency Extension Unit	1-0	8-8. Pulse Input (A1TP9, 5V per division) vs. Waveform at A1TP8 (0.2V per division, ac coupled). Horizontal scale: 1 μ s per division	8-24
1-3. Signal Generator System Simplified Block Diagram	1-3	8-9. Pulse Input (A1TP9, 5V per division) vs. Waveform at A1TP10 (0.2V per division, ac coupled). Horizontal scale: 1 μ s per division	8-24
2-1. Line Voltage Selection and Fuse Replacement	2-3	8-10. Pulse Input (A1TP9, 5V per division) vs. Waveform at A1TP11 (0.5V per division). Horizontal scale: 1 μ s per division	8-24
2-2. Power Cable and Mains Plug Part Number	2-3	8-11. Pulse Input (A1TP9, 5V per division) vs. Waveform at A1TP11 (2V per division). Horizontal scale: 1 μ s per division	8-24
2-3. HP-IB Address Selection	2-4	8-12. Pulse Input (A1TP9, 5V per division) vs. Waveform at A1TP17 (2V per division). Horizontal scale: 1 μ s per division	8-24
2-4. Hewlett-Packard Interface Connections	2-6	8-13. A1 Pulse Driver Assembly Component Locations	8-25
3-1. Front Panel Features	3-5	8-14. Pulse Driver Circuits Schematic Diagram	8-25
3-2. Rear Panel Features	3-6	8-15. A10 ALC Amplifier (CW) Assembly Component Locations	8-27
4-1. Frequency Range and Power Test Setup	4-4	8-16. ALC Amplifier (CW) Schematic Diagram	8-27
4-2. Pulse Modulation Test Setup	4-5	8-17. Digital Sample-and-Hold Timing Diagram	8-28
4-3. Frequency Range and Resolution Test Setup	4-6	8-18. A10 ALC Amplifier (CW and Pulse) Assembly Component Locations	8-29
4-4. On/Off Ratio Test Setup	4-8	8-19. ALC Amplifier (CW and Pulse) Schematic Diagram	8-29
4-5. Pulse Performance Test Setup	4-9	8-20. A7 Rear Panel Assembly Component Locations	8-30
4-6. Pulse Performance Parameters	4-10	8-21. A8 HP-IB Connector Board Assembly Component Locations	8-30
4-7. Pulse Accuracy Measurement	4-10	8-22. A5 HP-IB Assembly Component Locations	8-31
5-1. Low Band Adjustment Setup	5-2	8-23. HP-IB Handshake and Data Input Circuits Schematic Diagram	8-31
5-2. Voltmeter Connection	5-4	8-24. A11 Front Panel Assembly Component Locations	8-32
5-3. Current Measuring Adapter	5-6	8-25. A4 Remote/Local Logic Assembly Component Locations	8-33
5-4. Rise and Fall Time Adjustment Setup	5-7	8-26. Remote/Local Logic Circuits Schematic Diagram	8-33
5-5. Bias Pulse Adjustment Waveform	5-8	8-27. A3 Latch Assembly Component Locations	8-35
6-1. FEU Front Panel Chassis and Mechanical Parts Identification	6-20	8-28. Latch Circuits Schematic Diagram	8-35
6-2. FEU Rear Panel Chassis and Mechanical Parts Identification	6-20		
6-3. FEU Top Chassis Parts, Mechanical Parts, and Cable Identification	6-21		
6-4. Cabinet Parts	6-22		
8-1. Analog and Pulse Modulator Circuits Block Diagram	8-17		
8-2. Simplified HP-IB Handshake Between Talker and One Listener	8-19		
8-3. HP-IB and Front Panel Circuits Block Diagram	8-21		
8-4. RF Paths (Standard, Option 004, and Option 005) Component Locations	8-21		
8-5. RF Paths (Standard, Option 004 and Option 005) Schematic Diagram	8-21		
8-6. RF Paths (Options 009 and 010) Schematic Diagram	8-23		

LIST OF ILLUSTRATIONS (cont'd)

Figure	Page	Figure	Page
8-29. A2 Driver Assembly Component Locations	8-37	8-33. A1 Pulse Driver Power Supply Component Locations	8-41
8-30. Driver Circuits Schematic Diagram	8-37	8-34. Pulse Driver Power Supply Circuits Schematic Diagram	8-41
8-31. A6 Motherboard Assembly Component Locations	8-39	8-35. A9 ALC Power Supply Assembly Component Locations	8-43
8-32. Main Power Supply Circuits Schematic Diagram	8-39	8-36. ALC Power Supply Circuit Schematic Diagram	8-43

TABLES

Table	Page	Table	Page
1-1. HP 8672S Signal Generator System Specifications	1-2	3-4. Signal Generator System Programming Example (HP 85F BASIC Language)	3-7
1-2. HP 8672S Signal Generator System Supplemental Characteristics	1-3	3-5. FEU Operator's Remote Checks	3-8
1-3. 86720A FEU Supplemental Characteristics	1-3	3-6. HP-IB Message Reference Table for the FEU	3-10
1-4. Summary of Signal Generator System Options	1-4	4-1. Summary of performance Tests	4-2
1-5. Recommended Test Equipment	1-7	4-2. Performance Test Record	4-12
2-1. Fuse Ratings and Part Numbers	2-1	5-1. Factory Selected Components	5-1
2-2. Accessories Supplied With the FEU	2-4	6-1. Reference Designations	6-2
2-3. ASCII Address Codes to Decimal Equivalents	2-5	6-2. Abbreviations	6-2
3-1. Output Power for the HP 8672S Option 008 Signal Generator System	3-3	6-3. Replaceable Parts	6-4
3-2. FEU Programming Quick Reference Guide	3-3	6-4. Code List of Manufacturers	6-23
3-3. Signal Generator Programming Quick Reference Guide	3-4	8-1. Schematic Diagram Notes	8-2
		8-2. Etched Circuit Soldering Equipment	8-11
		A-1. Manual Changes by Serial Number Prefix ..	A-1

SAFETY CONSIDERATIONS

GENERAL – This is a Safety Class I instrument (provided with terminal for protective earthing).

OPERATION – BEFORE APPLYING POWER verify that the power transformer primary is matched to the available line voltage, the correct fuse is installed, and Safety Precautions are taken (see the following warnings). In addition, note the instrument’s external markings which are described under “Safety Symbols.”

WARNINGS

Servicing instructions are for use by service-trained personnel only. To avoid dangerous electric shock, do not perform any servicing unless qualified to do so.

BEFORE SWITCHING ON THE INSTRUMENT, the protective earth terminal of the instrument must be connected to the protective conductor of the (mains) power cord. The mains plug shall only be inserted in a socket outlet provided with a protective earth contact. The protective action must not be negated by the use of an extension cord (power cable) without a protective conductor (grounding). Grounding one conductor of a two conductor outlet is not sufficient protection.

If this instrument is to be energized via an auto-transformer (for voltage reduction) make sure the common terminal is connected to the neutral (that is, the grounded side of the Mains supply).

Any interruption of the protective (grounding) conductor (inside or outside the instrument) or disconnecting the protective earth terminal will cause a potential shock hazard that could result in personal injury.

Whenever it is likely that the protection has been impaired, the instrument must be made inoperative and be secured against any unintended operation.

Only fuses with the required rated current, voltage, and specified type (normal blow, time delay, etc.) should be used. Do not use repaired fuses or short circuited fuseholders. To do so could cause a shock or fire hazard.

Do not operate the instrument in the presence of flammable gases or fumes. Operation of any electrical instrument in such an environment constitutes a definite safety hazard.

Do not install substitute parts or perform any unauthorized modification to the instrument.

Adjustments described in the manual are performed with power supplied to the instrument while protective covers are removed. Energy available at many points may, if contacted, result in personal injury.

Any adjustment, maintenance, and repair of the opened instrument under voltage should be avoided as much as possible, and when inevitable, should be carried out only by a skilled person who is aware of the hazard involved.

Capacitors inside the instrument may still be charged even if the instrument has been disconnected from its source of supply.

SAFETY SYMBOLS



Instruction manual symbol: the product will be marked with this symbol when it is necessary for the user to refer to the instruction manual in order to protect against damage to the product.



Indicates hazardous voltages.



Earth terminal (sometimes used in manual to indicate circuit common connected to grounded chassis).

WARNING

The **WARNING** sign denotes a hazard. It calls attention to a procedure, practice, or the like, which, if not correctly performed or adhered to, could result in personal injury. Do not proceed beyond a **WARNING** sign until the indicated conditions are fully understood and met.

CAUTION

The **CAUTION** sign denotes a hazard. It calls attention to an operating procedure, practice, or the like, which, if not correctly performed or adhered to, could result in damage to or destruction of part or all of the product. Do not proceed beyond a **CAUTION** sign until the indicated conditions are fully understood and met.



Figure 1-1. HP 8672S Synthesized Signal Generator



Figure 1-2. HP 86720A Frequency Extension Unit

SECTION I GENERAL INFORMATION

1-1. INTRODUCTION

This manual contains the information required to install, operate, test, adjust, and service the Hewlett-Packard 8672S Synthesized Signal Generator System (Signal Generator System). The Signal Generator System (Figure 1-1) consists of an HP 8672A Synthesized Signal Generator (Signal Generator) and an HP 86720A Frequency Extension Unit (FEU). The Signal Generator used in the system must have either Option 034 or 038 installed. For detailed information on the Signal Generator, refer to the HP 8672A Operating and Service Manual. In addition to the Signal Generator System operating and service information, this manual also contains the operating and service information for the FEU (Figure 1-2).

This Operating and Service Manual has the following eight major sections:

- Section I, General Information
- Section II, Installation
- Section III, Operation
- Section IV, Performance Tests
- Section V, Adjustments
- Section VI, Replaceable Parts
- Section VII, Manual Changes
- Section VIII, Service

Listed on the title page of this manual, below the manual part number, is a microfiche part number. This number may be used to order 100 x 150 millimetre (4 x 6 inch) microfilm transparencies of this manual. Each microfiche contains up to 96 photo-duplicates of the manual pages. The microfiche package also includes the latest Manual Changes supplement, as well as all pertinent Service Notes.

1-2. SPECIFICATIONS

Specifications for the Signal Generator System are the same as those for the HP 8672A with the

exceptions and additions listed in Table 1-1. These specifications are the performance standards or limits against which the Signal Generator System can be tested. Supplemental characteristics for the Signal Generator System are listed in Table 1-2. Supplemental characteristics for the FEU are listed in Table 1-3. Supplemental characteristics are not warranted specifications, but are typical characteristics included as additional information for the user.

1-3. SAFETY CONSIDERATIONS

This product is a Safety Class I instrument, that is, one provided with a protective earth terminal. The Signal Generator System manual and all related documentation should be reviewed for familiarization with safety markings and instructions before operation. Refer to the Safety Considerations page found at the beginning of this manual for a summary of the safety information. Safety information for installation, operation, performance testing, adjustment, or service is found in appropriate places throughout this manual.

1-4. INSTRUMENTS COVERED BY MANUAL

Attached to the rear panel of the Frequency Extension Unit is a serial number plate. The serial number is in the form: 0000A00000. The first four digits and the letter are the serial number prefix. The last five digits are the suffix. The prefix is the same for identical instruments; it changes only when a configuration change is made to the instrument. The suffix however, is assigned sequentially and is different for each instrument. The contents of this manual apply directly to FEU's having serial number prefix(es) as listed under SERIAL NUMBERS on the title page.

The Signal Generator System is not serialized. Serial number information pertaining to the HP 8672A Synthesized Signal Generator is contained in the 8672A Operating and Service Manual.

1-5. MANUAL CHANGES SUPPLEMENT

An FEU manufactured after the printing of this manual may have a serial number prefix that is not listed on the title page. This unlisted serial

Table 1-1. HP 8672S Signal Generator System Specifications

Electrical Characteristics	Performance Limits	Conditions
<p>NOTE</p> <p>Specifications for the Signal Generator System are the same as those for the HP 8672A Synthesized Signal Generator with the exceptions and additions listed in this table.</p>		
<p>FREQUENCY Range</p> <p>Resolution</p>	<p>10 MHz to 18 GHz</p> <p>1 kHz</p> <p>2 kHz</p> <p>3 kHz</p>	<p>10 MHz to 6.199 999 GHz</p> <p>6.2 to 12.399 998 GHz</p> <p>12.400002 to 18 GHz</p>
<p>SPECTRAL PURITY Spurious Signals Non-harmonics</p> <p>Others (Power line related and fan rotation)</p> <p>Single-sideband Phase Noise (1 Hz BW, CW mode)</p>	<p><-60 dBc</p> <p>Same as 8672A 2.0 to 6.2 GHz</p> <p>Same as 8672A 2.0 to 6.2 GHz</p>	<p>10 MHz to 1.999 999 GHz</p> <p>10 MHz to 6.2 GHz</p> <p>10 MHz to 6.2 GHz</p>
<p>RF OUTPUT (CW Mode) Output Level</p> <p>Total Indicated Meter Accuracy</p> <p>Level Flatness</p>	<p>+13 dBm to -120 dBm</p> <p>+1 dBm (+7 dBm, Opt. 008) to -120 dBm</p> <p>Same as 8672A except degraded by 0.25 dB</p> <p>Same as 8672A 2—6.2 GHz except degraded by 0.5 dB</p> <p>Same as 8672A except degraded by ±0.25 dB</p>	<p>10 MHz to 2 GHz</p> <p>2 to 18 GHz</p> <p>2 to 18 GHz</p> <p>10 MHz to 2 GHz</p>
<p>MODULATION Frequency Modulation</p> <p>PULSE Modulation On/Off Ratio (0 dB Vernier Setting)</p> <p>Rise/Fall Times</p> <p>Peak Pulse Power</p>	<p>Same as 8672A 2—6.2 GHz</p> <p>>80 dB</p> <p><15 ns</p> <p>Within 1.0 dB of level selected in CW mode</p> <p>Uncalibrated</p>	<p>10 MHz to 2 GHz</p> <p>10 MHz to 2 GHz</p> <p>2—18 GHz</p>

Table 1-2. HP 8672S Signal Generator System Supplemental Characteristics

Power: 100, 120, 200 or 240 Vac, +5% -10% at 48 to 66 Hz, 405 VA maximum.
Net Weight: 39.5 kg (87 lbs).
Dimensions: 620 mm Deep x 425 mm Wide x 222 mm High (24.4" x 16.8" x 8.8").

Table 1-3. 86720A FEU Supplemental Characteristics

Power: 100 or 120 Vac, +5% -10% at 48 to 440 Hz, or 200 or 240 Vac, +5% -10% at 48 to 66 Hz, 105 VA maximum.
Net Weight: 12.3 kg (27 lbs).
Dimensions: 620 mm Deep x 425 mm Wide x 89 mm High (24.4" x 16.8" x 3.5").

Manual Changes Supplement (cont'd)

number prefix indicates that the instrument is different from those documented in this manual. The manual for this newer instrument is accompanied by a Manual Changes supplement. The supplement contains "change information" that explains how to adapt the manual to the newer instrument.

In addition to change information, the supplement may contain information for correcting errors in the manual. To keep the manual as current and as accurate as possible, Hewlett-Packard recommends that you periodically request the latest Manual Changes supplement. The supplement is identified with the manual print date and part number, both of which appear on the manual title page. Complimentary copies of the supplement are available from Hewlett-Packard.

For information concerning a serial number prefix that is not listed on the title page or in the Manual Changes supplement, contact your nearest Hewlett-Packard office.

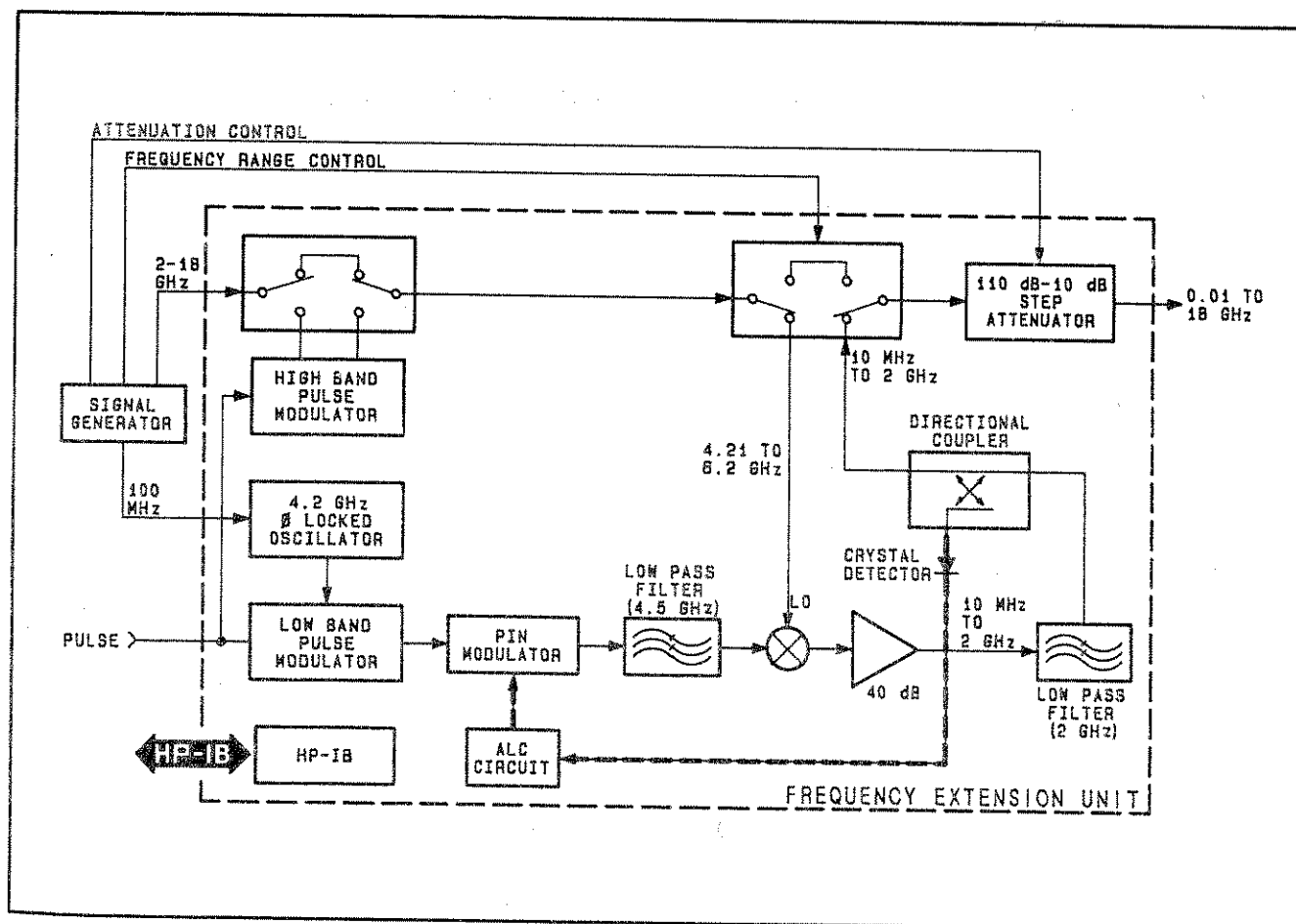

Figure 1-3. Signal Generator System Simplified Block Diagram

1-6. DESCRIPTION

Most HP 8672S Signal Generator Systems consist of an HP 86720A Frequency Extension Unit (FEU), an HP 8672A Option 034 Synthesized Signal Generator, and the accessories listed in Section II. Occasionally, a system that requires only high power output will contain an HP 8672A Option 038 (instead of the Option 034). Both of these options are covered in the HP 8672A Signal Generator Options paragraph.

The Signal Generator System (Figure 1-3) has a frequency range of 10 MHz to 18 GHz. The output is leveled and calibrated from +2 to -120 dBm (+7 to -120 dBm with Option 008) in the 2 to 18 GHz range and from +13 to -120 dBm in the 10 MHz to 2 GHz range. FM or pulse modulation can be selected through the entire range. AM modulation can be selected at 2 GHz and above.

1-7. Low Band and High Band

The FEU uses a heterodyne technique to generate low-band signals (10 MHz to 2 GHz). The input signal from the Signal Generator (4.21 to 6.2 GHz) is mixed with a 4.2 GHz oscillator to produce the low-band output signal. Both low-band and high-band signals (2 to 18 GHz) can be pulse modulated by the modulators in the FEU.

1-8. HP-IB Operation

Both the Signal Generator and the FEU have HP-IB interfaces and can be used with any HP-IB Controller for automatic Signal Generator System applications.

1-9. HP 8672S SIGNAL GENERATOR SYSTEM OPTIONS

The HP 8672S Signal Generator System options allow the user to specify changes to both the HP 8672A and the HP 86720A. Do not confuse the HP 8672S Signal Generator System options with the individual instrument (HP 8672A or HP 86720A) options. Table 1-4 summarizes the electrical options of the Signal Generator System (HP 8672S) and the related options in the Signal Generator (HP 8672A) and FEU (HP 86720A). For example, the standard HP 8672S contains an HP 8672A Option 034 Signal Generator. The descriptions of the electrical options specify what the option does and which instrument it changes.

The mechanical options are used to mechanically combine and mount the two instruments as a system.

Table 1-4. Summary of Signal Generator System Options

HP 8672S Options	HP 8672A Options	HP 86720A Options
Standard	034	Standard
001	038	001
002	002, 034	Standard
003	003, 034	Standard
004	034	004
005	038	005
006	034	006
008	008,034	Standard
009	034	009
010	038	010

1-10. Signal Generator System Electrical Options

Option 001. The .01 TO 18.0 GHz OUTPUT connector on the HP 86720A is mounted on the front panel but the internal attenuator is omitted. The specified output level is +4 to -10 dBm from 2 GHz to 18 GHz and +13 to -10 dBm from 10 MHz to 1.999 999 GHz. The HP 8672A Option 038 is used instead of the Option 034.

Option 002. The internal 10 MHz crystal reference in the HP 8672A is omitted. An external reference is required.

Option 003. A special fan in the HP 8672A allows the Signal Generator to operate from 48 to 440 Hz Mains. The standard FEU can operate over the same range.

Option 004. The .01 TO 18.0 GHz OUTPUT connector on the HP 86720A is mounted on the rear panel. Maximum output power is +12.0 dBm (10 MHz to 1.999 999 GHz). Total indicated level accuracy and flatness is degraded by ± 0.25 dB.

Option 005. The .01 TO 18.0 GHz OUTPUT connector on the HP 86720A is mounted on the rear panel and the internal attenuator is omitted. The specified power output is +3 to -10 dBm from 2 GHz to 18.0 GHz and +12 to -10 dBm from 10 MHz

Signal Generator System Electrical Options (cont'd)

to 1.999 999 GHz. The HP 8672A Option 038 is used instead of the Option 034. Total indicated accuracy and flatness is degraded by ± 0.25 dB.

Option 008. Provides +7 dBm leveled output power in the HP 8672A from 2.0 to 18.0 GHz. Refer to the HP 8672A Option 8 Manual Supplement.

Option 009. Delete the pulse modulation capability from the HP 86720A.

Option 010. Delete the pulse modulation capability from the HP 86720A and omit the internal attenuator. The specified output level is +4 to -10 dBm from 2 to 18 GHz and +13 to -10 dBm from 10 MHz to 1.999 999 GHz.

1-11. Signal Generator System Mechanical Options

The following options may have been ordered and received with the Signal Generator System. If they were not received with the original shipment and are now required, they can be ordered from your nearest Hewlett-Packard using the part number included in each of the following paragraphs.

Chassis Slide Mount Kit (Option 006). This kit is extremely useful when the Signal Generator System is rack mounted. Access to internal circuits of the HP 8672A Signal Generator and the rear panels of both instruments is possible without removing the Signal Generator System from the rack. Order HP part number 1494-0017. If the system rack mounting slides are to be mounted in a standard EIA rack, then an adapter (HP part number 1494-0023) is needed. The slides without the adapter can be directly mounted in the HP system enclosures.

Rack Flange Kit (Option 908). A Signal Generator System without handles can be solidly mounted to the instrument rack using this kit. Order HP part numbers 5061-0074 (for the FEU) and 5061-0077 (for the Signal Generator).

Rack Flange Kit for Mounting With Front Handles (Option 913). This kit contains a flange that can be used to mount the Signal Generator System with handles. The handles are included in the standard system. Order HP part number 5061-0085.

1-12. HP 8672A SYNTHESIZED SIGNAL GENERATOR OPTIONS

The HP 8672A options are covered in the HP 8672A documentation. However, it is important to understand the following relationships:

a. The standard HP 8672S Signal Generator System contains an HP 8672A, Option 034. This option omits the internal attenuator but uses the standard OUTPUT LEVEL RANGE switch. The physical and electrical changes to the HP 8672A are covered in the HP 8672A Operating and Service Manual. The difference in operation when the HP 8672A Signal Generator is a part of the HP 8672S Signal Generator System is covered in Section III of this manual.

b. If an HP 8672S Signal Generator System option deletes the internal attenuator from the FEU, the HP 8672A Signal Generator used in the system must be an Option 038. This option installs a two-position OUTPUT LEVEL RANGE switch in the Signal Generator.

c. The 002, 003, and 008 electrical options to the HP 8672A are equivalent to the same numbered options to the HP 8672S.

d. The remaining HP 8672A options are not normally used with the HP 8672S Signal Generator System.

1-13. HP 86720A FREQUENCY EXTENSION UNIT OPTIONS

The HP 86720A options are covered in this manual. These options (001, 004, 005, 009, and 010) are equivalent to the same numbered options to the HP 8672S.

1-14. HEWLETT-PACKARD INTERFACE BUS (HP-IB)

1-15. Compatibility

The Frequency Extension Unit is compatible with HP-IB to the extent indicated by the following code: SH0, AH1, T0, TE0, L2, LE0, DC0, DT0, RL1, C0, SR0 and PP0. An explanation of the compatibility code can be found in IEEE Standard 488 (1978), "IEEE Standard Digital Interface for Programmable Instrumentation" or the identical ANSI Standard MC1.1. The FEU interfaces with the bus via open collector TTL circuitry. For more detailed information relating to programmable control of the Frequency Extension Unit, refer to

Compatibility (cont'd)

Remote Operation, Hewlett-Packard Interface Bus in Section III of this manual.

1-16. Selecting the HP-IB Address

The Signal Generator System uses two HP-IB addresses. One is the HP-IB address of the HP8672A Signal Generator. The second is the HP-IB address of the HP 86720A FEU. These two addresses can not be the same. Refer to the HP 8672A Operating and Service Manual for additional information on setting or changing the Signal Generator HP-IB address. Refer to Section II of this manual for additional information on setting or changing the FEU HP-IB address.

1-17. ACCESSORIES SUPPLIED

The accessories supplied with the Signal Generator System consist of the accessories supplied with the Signal Generator (refer to the HP 8672A Operating and Service Manual) and the accessories supplied with the FEU (refer to Table 2-1).

1-18. EQUIPMENT REQUIRED BUT NOT SUPPLIED

If an FEU is purchased separately, an HP 8672A (Option 034 or Option 038) Synthesized Signal Generator must be used with the FEU to form a complete Signal Generator System. The 11731A or

11732A Frequency Extension Kit can be used to retrofit existing HP 8672A Synthesized Signal Generators for use in the HP 8672S Signal Generator System.

1-19. EQUIPMENT AVAILABLE

The Frequency Extension Unit has an HP-IB interface and can be used with any HP-IB compatible computing controller or computer for automatic systems applications.

The 11712A Support Kit is available to aid the user in maintaining and servicing the Signal Generator System. It consists of cables, adaptors, terminations, prerecorded programs, extender boards, and a test extender board.

Refer to the 11712A Support Kit Operating Manual for additional information. It can be ordered through a Hewlett-Packard sales office.

1-20. RECOMMENDED TEST EQUIPMENT

Table 1-5 lists the test equipment and accessories recommended for use in the testing, adjusting, and servicing procedures contained in this manual. Any additional equipment required for procedures in the HP 8672A Operating and Service Manual are listed in that manual. If any of the recommended equipment is unavailable, instruments with the equivalent minimum specifications can be used.

Table 1-5. Recommended Test Equipment

Instrument	Critical Specifications	Recommended Model	Use*
Attenuator	6 dB (not critical) Range: dc to 18 GHz SWR: 1.5 maximum	HP 8491B Option 006	P
Controller, HP-IB	HP-IB Compatible	HP 85F	A, T
Diode Detector	Range: 0.01 to 18 GHz SWR: 1.7 maximum Sensitivity: >0.4 mV/ μ /W1	HP 8472B	P, T
Frequency Counter	Range: 20 kHz to 18 GHz Resolution: 10 Hz	HP 5343A	P, T
Mixer	0.01 to 2 GHz response	ZFM-150**	P, T
Oscilloscope	Bandwidth: 200 Mhz Vertical Sensitivity: 10 mV/div Vertical Input: 50 Ω ac or dc coupled Delayed Sweep Mode: 20 ns/div External Sweep Capability	HP 1715A	P, A, T
Power Meter	Frequency Range: 0.01 to 18 GHz Accuracy: \pm 0.1 dB Compatible with Power Sensor	HP 436A	P, A, T
Power Sensor	Frequency Range: 0.01 to 18 GHz Input Impedance: 50 Ω Range: +17 to -25 dBm into 50 Ω	HP 8481A	P, A, T
Pulse Generator	Rate: 10 Hz to 4 MHz Rise and Fall Times: >5 dBm Output Impedance: 50 Ω Output Level: 0 to 3.5V Pulse Width: 100 ns to 2 μ /s	HP 8013B	P, A, T
Spectrum Analyzer	Frequency Range: 0.01 to 18 GHz Frequency Span 50 kHz to 200 MHz/div Resolution Bandwidth: 30 Hz to 300 kHz Amplitude Range: +13 to -120 dBm Vertical Sensitivity: 2 dB/div minimum	HP 8565A	P, T
Voltmeter, Digital	Range: +22 to -40 Vdc; 0 to 1 Vrms Resolution: 1 μ /V Vdc; 1 μ /V Vrms	HP 3455A	P, A, T
* P = Performance Testing, A = Adjustments, T = Troubleshooting			
**Mini-Circuits Lab, 2625 East 14th Street, Brooklyn, NY 11235, Tel (212) 769-0200.			

SECTION II INSTALLATION

2-1. INTRODUCTION

This section provides the information needed to install the complete system. Included is information pertinent to the initial inspection, power requirements, line voltage and fuse selection, operating environment, instrument mounting, storage, and shipment of the HP 86720A Frequency Extension Unit (FEU). For similar information about the Signal Generator, refer to Section II of the HP 8672A Operating and Service Manual. A procedure for interconnecting the two instruments is also included.

2-2. INITIAL INSPECTION

WARNING

To avoid hazardous electrical shock, do not perform electrical tests when there are signs of shipping damage to any portion of the outer enclosure (covers and panels).

Inspect the shipping container for damage. If the shipping container or cushioning material is damaged, it should be kept until the contents of the shipment have been checked for completeness and the instrument has been checked mechanically and electrically. The procedures for checking electrical performance are given in Section IV, Performance Tests. If the contents are incomplete, if there is a mechanical defect, or if the instrument does not pass the performance tests, notify the nearest Hewlett-Packard office. If the shipping container is damaged or the cushioning material shows signs of stress, notify the carrier and the Hewlett-Packard office. Keep the shipping material for the carrier's inspection.

2-3. PREPARATION FOR USE

2-4. Power Requirements

WARNING

To avoid the possibility of hazardous electrical shock, do not operate this instrument at line voltages greater than 126.5 Vac with line frequencies greater than 66 Hz. Leakage currents at these settings may exceed 3.5 mA.

Power requirements for the Signal Generator and the Frequency Extension Unit are listed in Tables 1-2 and 1-3.

WARNING

This is a Safety Class I product (i.e., provided with a protective earth terminal). An uninterruptible safety earth ground must be provided from the Mains power source to the product input wiring terminals, power cord, or supplied power cord set. Whenever it is likely that the protection has been impaired, the instrument must be made inoperative and secured against any unintended operation.

If the instrument is to be energized via an external autotransformer (for voltage reduction), make sure the common terminal is connected to neutral (that is, the grounded side of the mains supply).

2-5. Line Voltage and Fuse Selection

CAUTION

Before plugging this instrument into the Mains (line) voltage, be sure that the correct operating voltage and fuse have been selected.

Rear-panel line-power modules permits operation from 90 to 126 Vac sources or from 198 to 252 Vac sources. The number visible in the window on the module indicates the nominal line voltage (100, 120, 220 or 240 Vac) to which the instrument must be connected. Verify that the line voltage selection card and the fuse are matched to the power source to be used. Refer to Figure 2-1, Line Voltage and Fuse Selection. Table 2-1 lists the ratings and HP part numbers for the replaceable fuses.

Table 2-1. Fuse Ratings and Part Numbers

Line Voltage	Rating	Part Number
100/120V	1A, 250V	2100-0001
220/240V	0.75A, 250V	2110-0063

2-6. Power Cable

WARNING

For protection against fire hazards, the line fuse should be a 250V normal-blow fuse with the correct rating.

Before connecting this power, the protective earth terminal of each instrument must be connected to the protective conductor of the (Mains) power cord. The Mains plug shall be inserted only in socket outlets provided with a protective earth contact. The protective action must not be negated by the use of an extension cord (power cable) without a protective conductor (grounding). Grounding one conductor of a two-conductor outlet is not sufficient protection.

This instrument is equipped with a three-wire power cable. When connected to an appropriate ac power receptacle, this cable grounds the instrument cabinet. The type of power cable plug shipped with each instrument is determined by the country of destination. Refer to Figure 2-2 for the part numbers of the power cables and plugs available.

2-7. HP-IB Address Selection

The HP-IB listen address is switch selectable. The switch is located on the rear panel of the FEU as shown in Figure 3-2. Select the desired address as shown in Table 2-2. The address is set to decimal 28 at the factory, as shown in Figure 2-3. Refer to Section II of the HP 8672A Operating and Service Manual for HP-IB address selection for the Signal Generator.

2-8. Interconnection

Interconnection data for the Hewlett-Packard Interface Bus is provided in Figure 2-4.

2-9. Mating Connectors

The front-panel .01 TO 18.0 GHz OUTPUT connector requires a 50-ohm Type N male mating connector. The PULSE INPUT and 100 MHz REF INPUT connectors require 50-ohm BNC male mating connectors. Both types must be compatible with the specifications of US MIL-C-39012. Additional cables are listed under ACCESSORIES SUPPLIED in this section.

2-10. Operating Environment

The operating environment should be within the following limitations:

Temperature 0°C to 55°C
(15°C to 35°C for specified performance)
Humidity <95% relative
Altitude <4570 metres (15 000 feet)

2-11. Bench Operation

The instrument cabinet has plastic feet and fold-away tilt stands for convenience in bench operation. The plastic feet are designed to ensure proper stacking with other instruments in similar housings, and the tilt stands raise the front of the system for easier viewing of the front panel.

2-12. Rack Mounting

WARNING

The entire system weighs 39.5 kg (87 lbs); therefore, care must be exercised when lifting to avoid personal injury.

Installation instructions are provided with the rack mounting kits.

2-13. ACCESSORIES SUPPLIED

The accessories supplied with the FEU consist of mounting hardware, accessory cables, and handles as listed in Table 2-2.

2-14. CONNECTING THE FREQUENCY EXTENSION UNIT TO THE SIGNAL GENERATOR

The Signal Generator System consists of an HP 8672A Signal Generator (Option 034 or 038), an HP 86720A FEU, and the accessories listed under Accessories Supplied. To mechanically mount and electrically interconnect the two instruments, perform the following steps:

- a. Remove the bottom feet from the Signal Generator.
- b. Attach the two Front Vertical Lock Links MP1,2 to the top of the front frame of the FEU with the hooks toward the front. Use four Pan Head screws MP13-16.
- c. Place the Signal Generator on top of the FEU and slide it back to lock the front frames together.
- d. If required, remove the bottom rear feet on the Signal Generator and the top rear feet on the FEU.

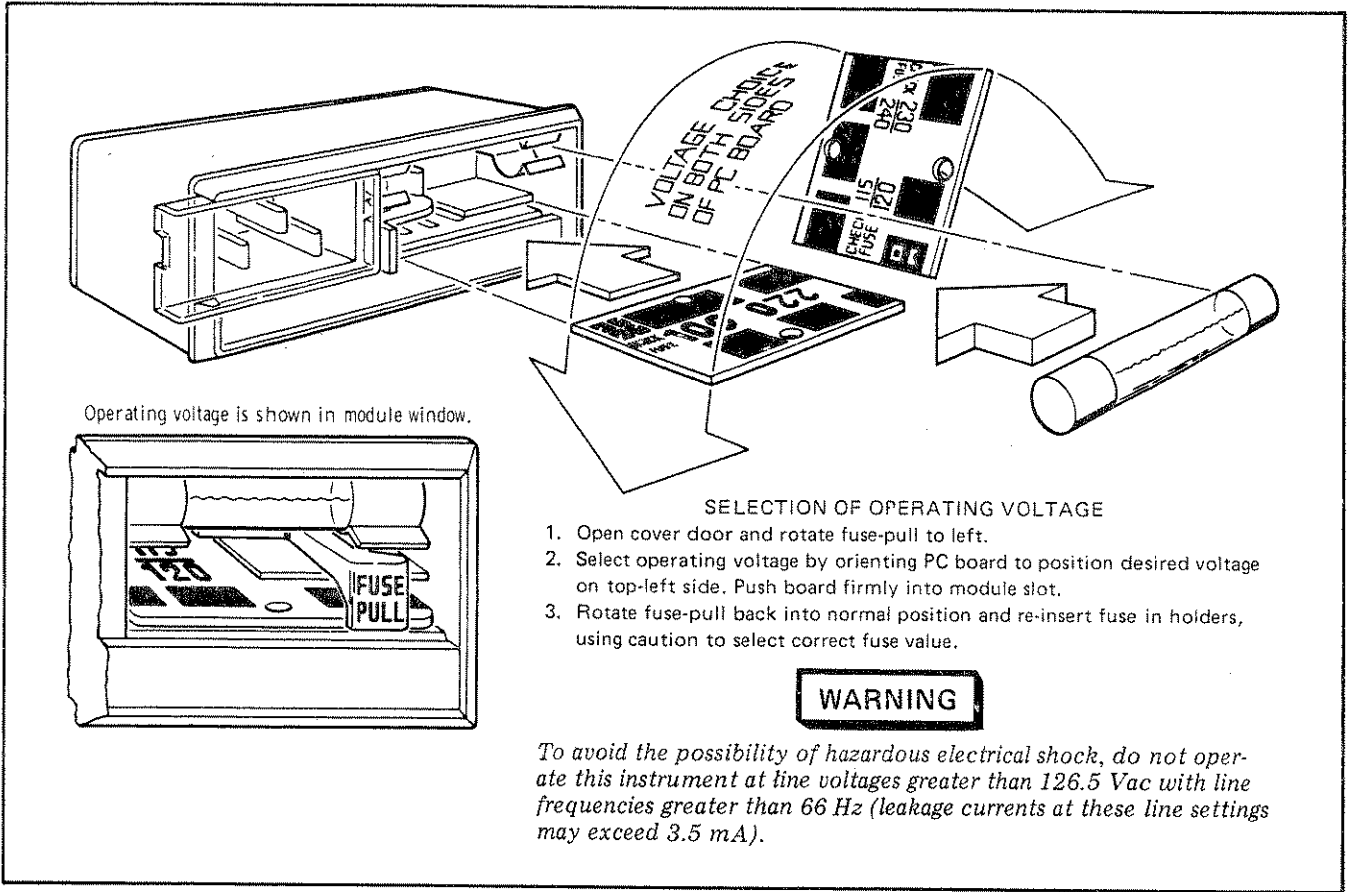

Figure 2-1. Line Voltage Selection and Fuse Replacement

<p>220/240V OPERATION</p>  <p>PLUG*: SEV 1011.1959-24507 TYPE 12 CABLE*: HP 8120-2104</p>	<p>220/240V OPERATION</p>  <p>PLUG*: NZSS 198/AS C112 CABLE*: HP 8120-1369</p>	<p>100/120V OPERATION</p>  <p>PLUG*: NEMA 5-15P CABLE*: 8120-1378</p>	<p>220/240V OPERATION</p>  <p>PLUG*: NEMA 6-15P CABLE*: HP 8120-0698</p>
<p>220/240V OPERATION</p>  <p>PLUG*: CEE7-VII CABLE*: HP 8120-1689</p>	<p>220/240V OPERATION</p>  <p>PLUG*: CEE22-V1 CABLE*: HP 8120-1860</p>	<p>220/240V OPERATION</p>  <p>PLUG*: BS 1363A CABLE: HP 8120-1351</p>	
<p>*The number shown for the plug is the industry identifier for the plug only. The number shown for the cable is an HP part number for a complete cable including the plug.</p>			

Figure 2-2. Power Cable and Mains Plug Part Numbers

Table 2-2. Accessories Supplied With the FEU

Reference Designation	Description	HP Part No.	Qty
W34	Cable, Line Power	See Figure 2-2	1
W35	Cable, Rigid Coaxial Assembly, RF IN	08672-20155	1
W36	Cable, Atten. Control	8120-3720	1
W37	BNC Cable, 21.5 cm (100 MHz Ref. Input)	8120-2682	1
W38	HP-IB Cable, 0.5 metre	10833D	1
MP1,2	Vertical Lock Link, Front	1600-0367	2
MP3,4	Vertical Lock Link, Rear	0050-0517	2
MP5,6	Handle Assembly	5060-9901	2
MP7,8	Handle Trim (plastic)	5020-8898	1
MP9-12	Feet, Rear	5040-7221	4
MP13-16	Screws, for mounting Front Vert. Lock Links (6-32 x .19 in PH)	2360-0330	4
MP17-20	Screws, for mounting rear Vert. Lock Links (6-32 x .31 in FH)	2360-0334	4
MP21-26	Screws, for mounting handles	2510-0195	6
MP27-30	Screws, for mounting Rear Feet (6-32 x .31 in RP)	2360-0195	4

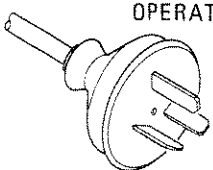
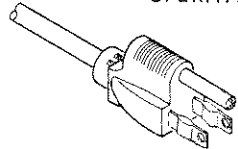
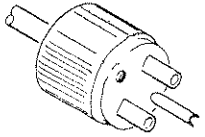
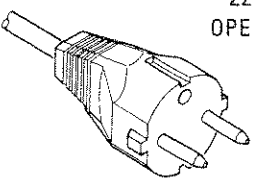
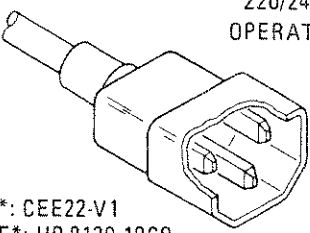
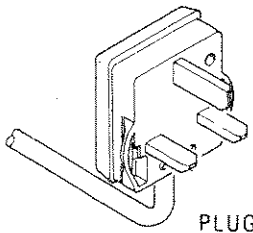
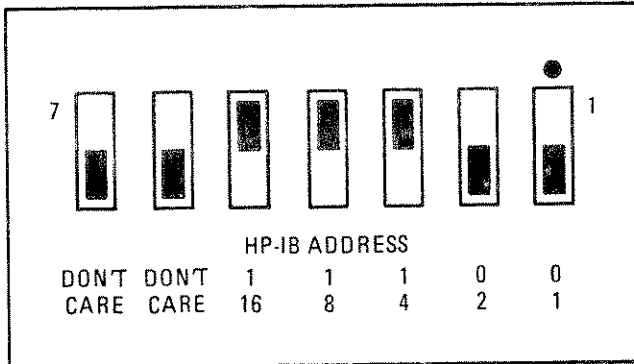

Figure 2-3. HP-IB Address Selection

Connecting Frequency Extension Unit to Signal Generator (cont'd)

e. Attach Rear Vertical Lock Links MP3,4 over bosses at the rear corners using screws MP17-20.

f. Attach Handles and Trim MP5-8, using screws MP21-26, or install either of the rack mounting kits supplied.

g. If required, install rear feet MP9-12 using screws MP27-30 on the four outside corners of the Signal Generator System.

h. Install Attenuator Control Cable W36 and 100 MHz Reference Input Cable W37 as shown in Figure 6-2.

i. If remote operation is desired, connect the HP-IB Cables to both the Signal Generator and the FEU.

j. Install W35 RF In Cable Assembly as shown in Figure 6-1.

2-15 STORAGE AND SHIPMENT

2-16. Environment

The instrument should be stored in a clean, dry environment. The following environmental limitations apply to both storage and shipment.

- Temperature -55°C to +75°C
- Humidity <95% Relative
- Altitude <15 300 metres (50 000 feet)

2-17. Packaging

CAUTION

Ship the Signal Generator and the FEU in two separate packages. The excessive weight could damage the instruments if they are shipped in one package.

Original Packaging. Containers and material identical to those used in factory packaging are available through Hewlett-Packard offices. If the instrument is being returned to Hewlett-Packard for

Table 2-3. ASCII Address Codes to Decimal Equivalents

ASCII Address Codes LISTEN	Decimal Equivalents
SP	00
!	01
"	02
#	03
\$	04
%	05
&	06
'	07
(08
)	09
*	10
+	11
,	12
-	13
.	14
/	15
0	16
1	17
2	18
3	19
4	20
5	21
6	22
7	23
8	24
9	25
:	26
;	27
<	28†
=	29
>	30

†indicates factory set address.

Packaging (cont'd)

servicing, please complete one of the blue repair tags located at the end of this manual and attach it to the instrument. Be sure to include the type of service required, return address, model number, and full serial number. Mark the container FRAGILE to assure careful handling. In any correspondence concerning a Hewlett-Packard instrument, refer to the instrument by model number and include the full serial number.

Other Packaging. The following general instructions should be followed for repackaging with commercially available packaging materials.

a. Complete one of the blue service tags located at the end of this manual and attach it to the instrument. Be sure to indicate the type of service required, return address, model number, and full serial number. Then wrap the instrument in heavy paper or plastic.

b. Use a strong shipping container. A double-wall carton made of 2.4 MPa (350 psi) test material is adequate.

c. Use enough shock absorbing material (75 to 100 mm or 3 to 4 inch layer) around bottom, top, and all sides to provide a firm cushion and to prevent movement within the container.

d. Seal the shipping container securely.

e. Mark the shipping container FRAGILE to assure careful handling.

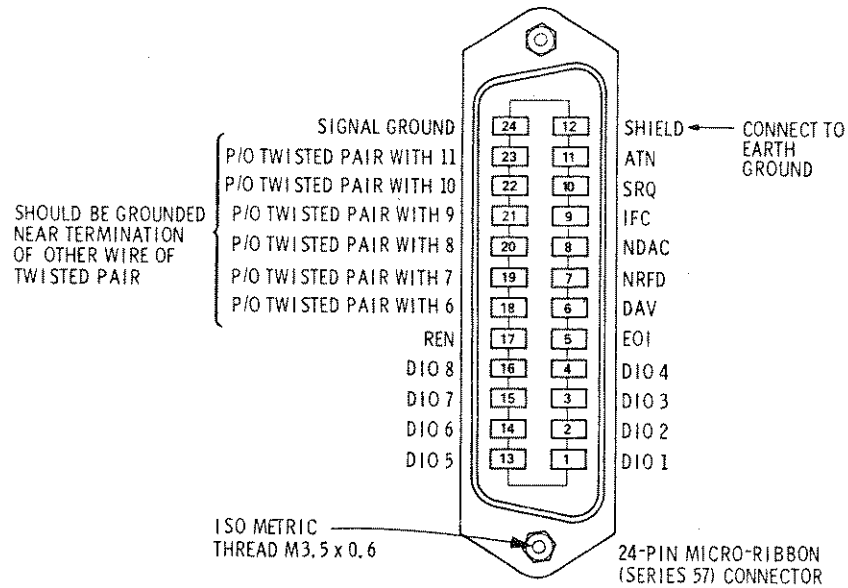

Logic Levels

The Hewlett-Packard Interface Bus Logic Levels are TTL compatible, i.e., the true (1) state is 0.0 Vdc to +0.4 Vdc and the false (0) state is +2.5 Vdc to +5.0 Vdc.

Programming and Output Data Format

Refer to Section III, Operation.

Mating Connector

HP 1251-0293; Amphenol 57-30240.

Mating Cables Available

HP 10833A, 1 metre (3.3 ft), HP 10833B, 2 metres (6.6 ft)
 HP 10833C 4 metres (13.2 ft), HP 10833D, 0.5 metres (1.6 ft)

Cabling Restrictions

1. A Hewlett-Packard Interface Bus system may contain no more than 2 metres (6.6 ft) of connecting cable per instrument.
2. The maximum accumulative length of connecting cable for any Hewlett-Packard Interface Bus system is 20.0 metres (65.6 ft).

Figure 2-4. Hewlett-Packard Interface Bus Connection

SECTION III OPERATION

3-1. INTRODUCTION

This section explains how to operate the Signal Generator System. Efficient operation of the system requires an understanding of the operation of both the HP 8672A Synthesized Signal Generator (Signal Generator) and the HP 86720A Frequency Extension Unit (FEU).

Because most users require system operating information more often than FEU operating information, the section is organized in the following format:

1. Local Operation.
 - a) Turn-on procedure.
 - b) Signal Generator System operation.
 - c) FEU operation.
2. Remote Operation.
 - a) Signal Generator System operation.
 - b) FEU operation.
3. Signal Generator System Operator's Checks.

NOTE

The operation of the FEU can best be checked by operating it in a Signal Generator System.

- a) Operator's local check.
 - b) Operator's remote check.
4. Operator's Maintenance.

Most Signal Generator functions are covered in the HP 8672A Operating and Service Manual. However, the relationship between the Signal Generator and the FEU when they are used as a system is explained in this section. For example, the use of the Signal Generator RANGE dBm display and the FEU vernier meter during low band operation is covered.

3-2. LOCAL OPERATION

Included in this section are the descriptions of the FEU front and rear panel controls, connectors and indicators, operator's checks, and operator maintenance.

Operation of the following Signal Generator functions are described in the HP 8672A Operating and Service Manual:

- a. Setting the output frequency.
- b. Setting modulation (except pulse modulation which is covered in this section).
- c. Setting output level range.
- d. Setting the high band output level vernier. Setting the low band output level vernier is covered in this section.
- e. RF On/Off.
- f. The remaining Signal Generator functions.

3-3. Turn-on Procedure

WARNINGS

Before the instruments are switched on, all protective earth terminals, extension cords, auto-transformers and devices connected to them should be connected to a protective earth grounded socket. Any interruption of the protective earth grounding will cause a potential shock hazard that could result in personal injury.

Only fuses with the required rated current and specified type should be used. Do not use repaired fuses or short circuited fuseholders. To do so could cause a shock or fire hazard.

CAUTIONS

Before the system is switched on, the instruments must be set to the voltage of the power source or damage to the system may result.

The FEU .01 TO 18.0 GHz OUTPUT is protected against reverse power applications up to 1W. However, for greatest protection of expensive internal components, be careful not to apply any reverse power to the .01 TO 18.0 GHz OUTPUT. 

Turn-on Procedure (cont'd)

If the Signal Generator and the FEU are already plugged in, set both LINE switches to ON.

If the power cables are not plugged in, follow these instructions:

1. Check that power line voltage settings match the power source (see Figure 2-1 for the FEU and the HP 8672A Operating and Service Manual for the Signal Generator).
2. Check that fuse ratings are appropriate for the line voltage used.
3. Plug in the power cables.
4. Set the LINE switches to ON.

3-4. Signal Generator System Local Operation

Efficient operation of the Signal Generator System requires that you understand the following information:

- a. Operation of the Signal Generator. This information is contained in the HP 8672A Operating and Service Manual.
- b. Operation of the FEU. This information is covered later in this section.
- c. How the two instruments operate together to extend the capabilities of the Signal Generator. This information is covered in the following paragraphs.

When the two instruments are used together, the resulting Signal Generator System extends the HP 8672A Synthesized Signal Generator capabilities by adding the following:

- a. A low band frequency range of 10 MHz to 2 GHz.
- b. Pulse modulation in both the low band and the high band.

See Table 1-1 for the system specifications that apply to these modes of operation.

3-5. Low Band Frequency Range Operation

Operation in the low band frequency range (10 MHz to 2 GHz) is jointly controlled by the Signal Generator and the FEU. The FEU CW/PULSE switch selects either CW or PULSE operation.

During CW operation, the Signal Generator controls all of the output signal characteristics except the vernier power setting. Vernier power is set using the OUTPUT VERNIER control on the FEU. The vernier power is indicated on the FEU front panel meter. The indication on the FEU meter is used in conjunction with the power indicated by the RANGE dBm LEDs on the Signal Generator to determine power output of the Signal Generator System. For example, if the FEU meter indicates -6 dBm and the Signal Generator LEDs indicate -10 dBm, the system power output is -16 dBm. This relationship is the same as the Signal Generator meter and display operation during high-band operation.

During low-band operation, FM modulation can be used (and displayed on the Signal Generator meter). AM modulation cannot be used in the low band. If AM modulation is selected, the LVL UNCAL LED on the FEU lights.

During pulse modulation operation, the Signal Generator controls the RF frequency and the 10 dB per step power range setting. The FEU controls the type of pulse modulation (normal or complement) and the vernier power setting. The vernier power is set while in the CW mode of operation. When the FEU is switched to PULSE, the low-band automatic level control (ALC) circuits maintain the peak power output at ± 1 dB of the last CW setting.

The instrument supplying the pulse input to the FEU controls the pulse width and the pulse repetition frequency (PRF).

If the system is operating in the low band, the PRESET key must be pressed twice to preset the system. The reason for this requirement is that a frequency command must be repeated any time the 2 GHz boundary between the low and high bands is crossed.

3-6. High Band Frequency Range Operation

CW operation in the high-band frequency range (2 to 18 GHz) is the same as operating an HP 8672A Synthesized Signal Generator.

Pulse modulation in this band is similar to that previously described for low band operation. The differences are that the vernier power setting now is controlled on the Signal Generator and the power output is not calibrated or leveled. The peak pulse power output of the system in this mode is

High Band Frequency Range Operation (cont'd)
 typically 4 to 6 dB lower than indicated on the Signal Generator. See Table 3-1 for a comparison between CW and pulse operation in a Signal Generator System with Option 008.

Table 3-1. Output Power for the HP 8672S Option 008 Signal Generator System

Frequency Range	CW Mode (dBm)	Pulse Modulation Mode (dBm)
10 MHz to 2 GHz	+13	+13
2 to 12.4 GHz	+7	+3*
12.4 to 18.0 GHz	+7	+1*
* Typical values		

3-7. FEU Local Operation

3-8. Panel Features

The front and rear panel features of the FEU are given in Figures 3-1 and 3-2. These include explanations of the controls, connectors and indicators.

3-9. FEU Operator's Local Check

Perform the Signal Generator System Verification Test in Section IV to verify local FEU operation.

3-10. REMOTE OPERATION

3-11. Signal Generator System Remote Operation

Remote operation of the Signal Generator System requires that you understand how to program the individual instruments. After that, the system program can be written in the same sequence that the controls on the individual instruments are set.

3-12. Programming Quick Reference Guides

Tables 3-2 and 3-3 are quick reference guides for programming the Signal Generator and the FEU.

Table 3-2 shows the program string syntax and program codes for the FEU. The FEU cannot send

a status byte. However, as explained later in this section, normal operation of the FEU can cause some bits of the the Signal Generator's status byte to be set.

Table 3-3 shows the program string syntax, program codes and arguments, and the status byte for the Signal Generator. All possible program codes (including equivalent duplicates) are shown, but the recommended codes are indicated with bold-face type.

Table 3-2. FEU Programming Quick Reference Guide

<p style="text-align: center;"> CW/Pulse Vernier Level { Controller Talk / FEU Listen }, Code "[XX][XX][X...X]" </p> <p style="text-align: center;">(UPPER OR LOWER CASE CAN BE USED)</p>	
Active Switch	Programming Codes
CW	a0
PULSE	b0
(Normal)	a5
(Complement)	b5
Remote Vernier Level	Program Code
+3 dBm	b1234
+2 dBm	a1b234
+1 dBm	a2b134
0 dBm	a12b34
-1 dBm	a3b124
-2 dBm	a13b24
-3 dBm	a23b14
-4 dBm	a123b4
-5 dBm	a4b123
-6 dBm	a14b23
-7 dBm	a24b13
-8 dBm	a124b3
-9 dBm	a34b12
-10 dBm	a134b2
-11 dBm	a234b1
-12 dBm	a1234

Table 3-3. Signal Generator Programming Quick Reference Guide

PROGRAM STRING SYNTAX

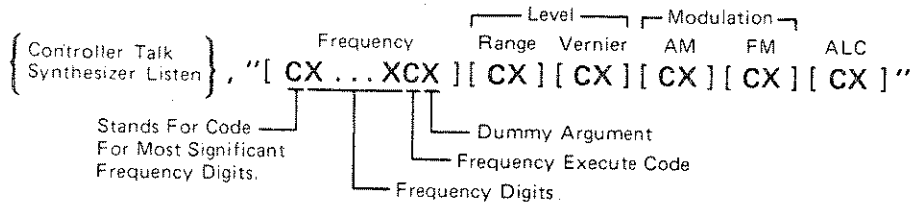

WHERE: C = PROGRAM CODE
X = ARGUMENT OR FREQUENCY DIGIT

	PROGRAM CODES	ARGUMENTS
FREQUENCY	10 GHz @ or P 1 GHz A or Q 100 MHz B or R 10 MHz C or S 1 MHz D or T 100 kHz E or U 10 kHz F or V 1 kHz G or W EXECUTE J or Z	Ø THROUGH 9
FM	N or ^	OFF 6 or 7 30 kHz 5 100 kHz 4 300 kHz 3 1 MHz 2 3 MHz 1 10 MHz Ø
ALC	0 or _	RF OFF 0,2,4,6,8 INT NORMAL 1 INT, +10 RANGE 3 XTAL, NORMAL 5 XTAL, +10 RANGE 7 MTR, NORMAL = MTR, +10 RANGE ?

	PROGRAM CODES	ARGUMENTS
OUTPUT LEVEL RANGE	K or [0 dBm Ø -10 1 -20 2 -30 3 -40 4 -50 5 -60 6 -70 7 -80 8 -90 9 -100 : -110 ;
OUTPUT LEVEL VERNIER	L or \	+3 dB Ø +2 1 +1 2 0 3 -1 4 -2 5 -3 6 -4 7 -5 8 -6 9 -7 : -8 ; -9 < -10 =
AM	M or]	OFF 0 or 1 100% 2 30% 3

STATUS BYTE

Bit Number	8	7	6	5	4	3	2	1
Decimal Value	128	64	32	16	8	4	2	1
Function	CRYSTAL OVEN COLD	RSV REQUEST SERVICE	OUT OF RANGE (frequency)	RF OFF	NOT PHASE LOCKED	LEV UNCAL	FM OVER-MOD	+10 dBm OVER RANGE

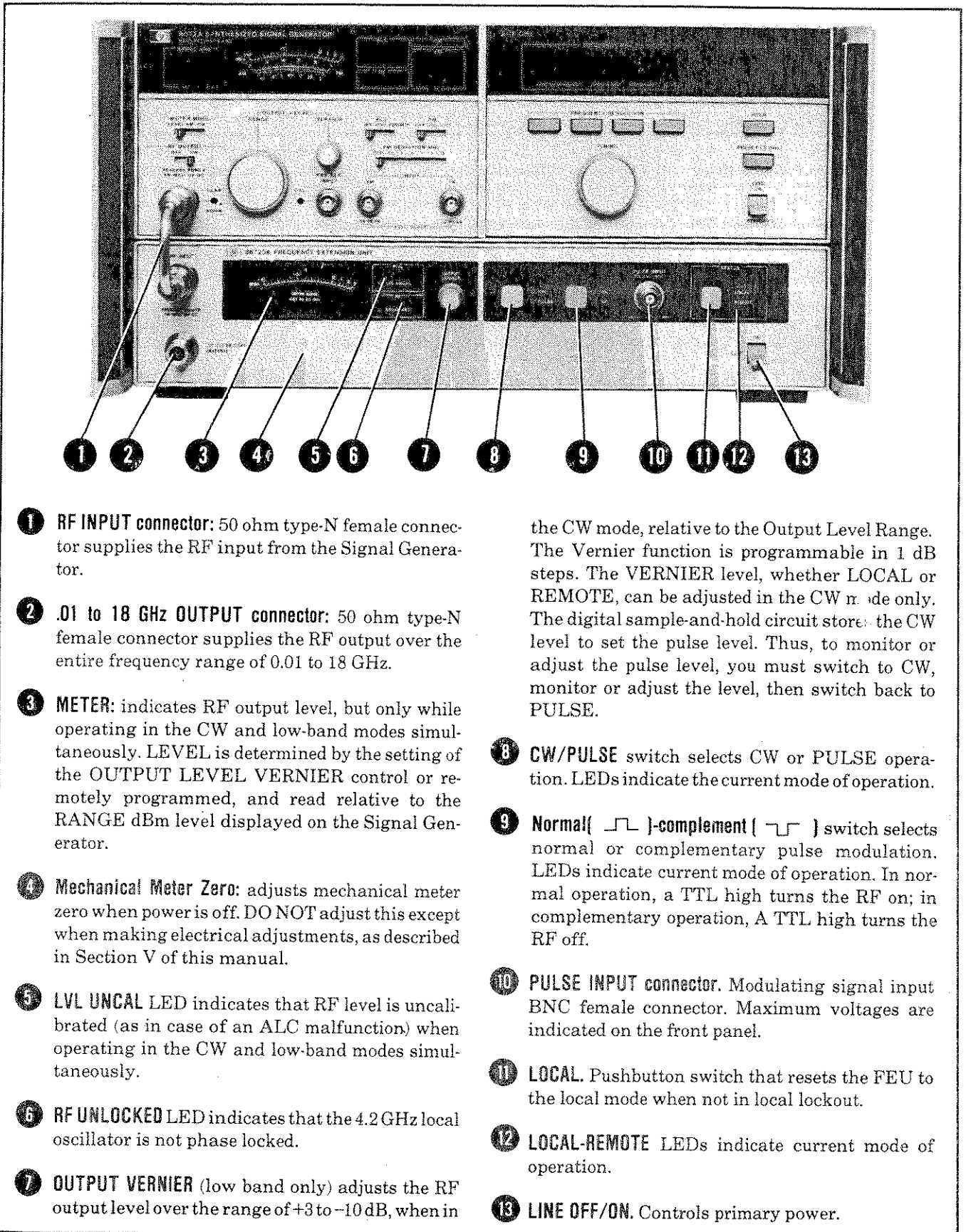

- 1 **RF INPUT connector:** 50 ohm type-N female connector supplies the RF input from the Signal Generator.
- 2 **.01 to 18 GHz OUTPUT connector:** 50 ohm type-N female connector supplies the RF output over the entire frequency range of 0.01 to 18 GHz.
- 3 **METER:** indicates RF output level, but only while operating in the CW and low-band modes simultaneously. LEVEL is determined by the setting of the OUTPUT LEVEL VERNIER control or remotely programmed, and read relative to the RANGE dBm level displayed on the Signal Generator.
- 4 **Mechanical Meter Zero:** adjusts mechanical meter zero when power is off. DO NOT adjust this except when making electrical adjustments, as described in Section V of this manual.
- 5 **LVL UNCAL LED** indicates that RF level is uncalibrated (as in case of an ALC malfunction) when operating in the CW and low-band modes simultaneously.
- 6 **RF UNLOCKED LED** indicates that the 4.2 GHz local oscillator is not phase locked.
- 7 **OUTPUT VERNIER** (low band only) adjusts the RF output level over the range of +3 to -10 dB, when in

the CW mode, relative to the Output Level Range. The Vernier function is programmable in 1 dB steps. The VERNIER level, whether LOCAL or REMOTE, can be adjusted in the CW mode only. The digital sample-and-hold circuit stores the CW level to set the pulse level. Thus, to monitor or adjust the pulse level, you must switch to CW, monitor or adjust the level, then switch back to PULSE.



- 8 **CW/PULSE** switch selects CW or PULSE operation. LEDs indicate the current mode of operation.
- 9 **Normal ()-complement ()** switch selects normal or complementary pulse modulation. LEDs indicate current mode of operation. In normal operation, a TTL high turns the RF on; in complementary operation, A TTL high turns the RF off.
- 10 **PULSE INPUT connector.** Modulating signal input BNC female connector. Maximum voltages are indicated on the front panel.
- 11 **LOCAL.** Pushbutton switch that resets the FEU to the local mode when not in local lockout.
- 12 **LOCAL-REMOTE** LEDs indicate current mode of operation.
- 13 **LINE OFF/ON.** Controls primary power.

Figure 3-1. Front Panel Features



- ① **FROM 8672A ATTEN CONTROL.** Connector to accept cable plug from the Signal Generator.
- ② **HP-IB Connector** connects the instrument to the Hewlett-Packard Interface Bus for remote operation. When in remote mode, the front-panel REMOTE LED lights.
- ③ **HP-IB Address.** Switches to set the address of the instrument. It is set to decimal 28 (11100) at the factory.
- ④ **Line Power Module** permits operation from 100, 120, 220, or 240 Vac. The number visible in window

- ⑤ **Line Voltage Selection Card.** Matches transformer primary to line voltage. indicates nominal line voltage to which instrument must be connected (see Figure 2-1). Center conductor is safety earth ground.
- ⑥ **Fuse.** Refer to Section II for values.
- ⑦ **100 MHz REF INPUT.** Connector for external input from the Signal Generator or external frequency standard.

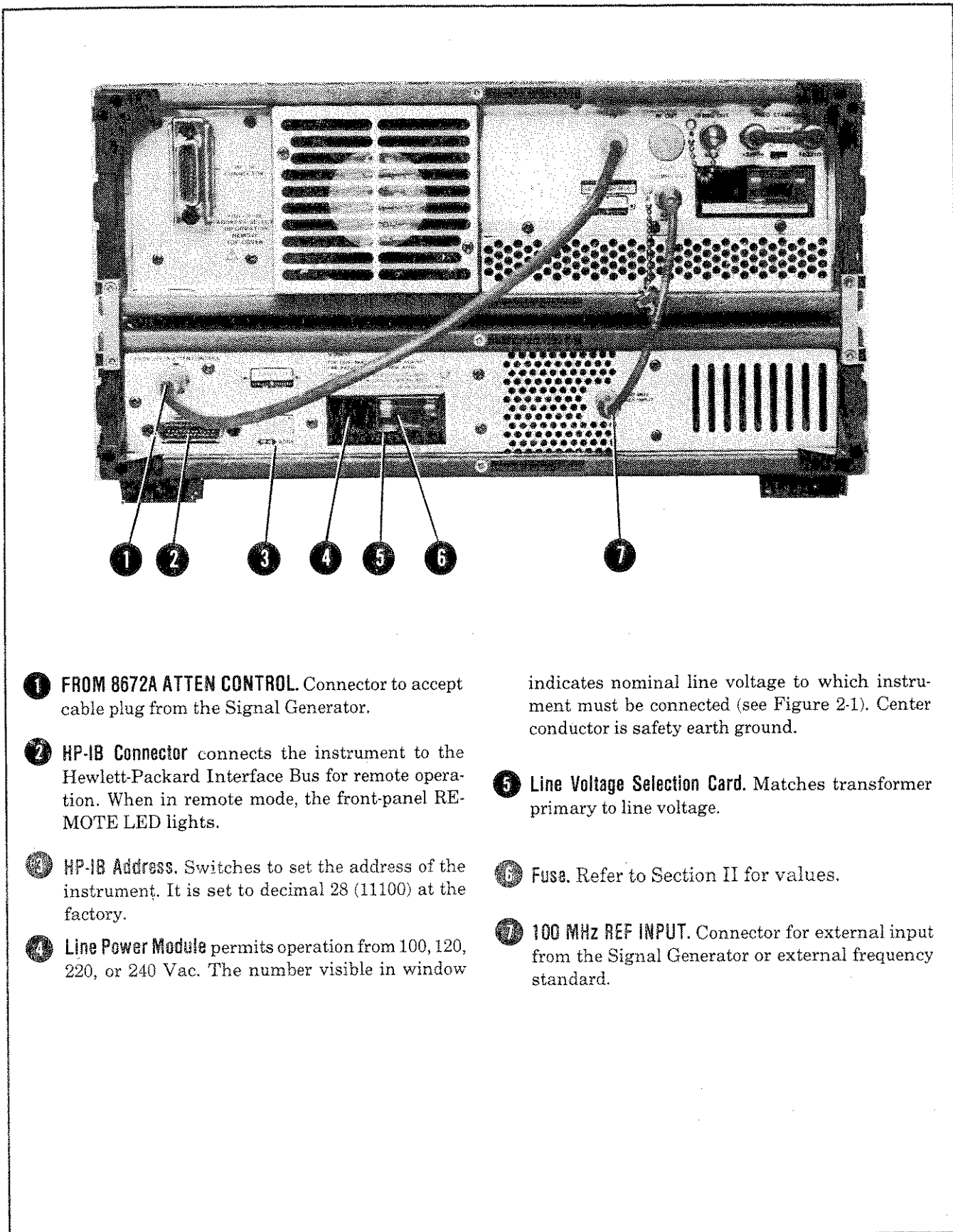
Figure 3-2. Rear Panel Features

3-13. Programming Example and Tips

The example in Table 3-4 sets the Signal Generator System to normal pulse modulation at 1000 MHz and +13 dBm:

Table 3-4. Signal Generator System Programming Example
(HP 85F BASIC Language)

```

10 REMOTE 7
20 CLEAR 719
30 OUTPUT 719 ; "0100000020"
40 OUTPUT 719 ; "0100000020"
50 OUTPUT 719 ; "03"
60 OUTPUT 728 ; "A0"
70 OUTPUT 728 ; "B1234"
80 OUTPUT 728 ; "B0"
90 OUTPUT 728 ; "B5"
100 END

```

When programming the Signal Generator System keep the following points in mind:

a. The Signal Generator and the FEU must have different addresses. In the example shown above, the factory set addresses for the two instruments are used (719 for the Signal Generator and 728 for the FEU).

b. When a frequency command is sent to the Signal Generator that causes the frequency to cross the 2 GHz boundary between the low and high band, the command must be sent twice. Therefore, to avoid confusion, it is recommended that all frequency commands be sent twice as shown in lines 30 and 40.

c. Because the CLEAR command (line 20) can cause the system frequency to cross the 2 GHz boundary, it should be used carefully. Refer to the HP 8672A Operating and service Manual for complete information on the use of the CLEAR command.

d. When the system is operating in the low band (10 MHz to 2 GHz), the LVL UNCALLED on the Signal Generator lights. This condition will initiate a service request (pulls SRQ line low). If the HP-IB controller is monitoring SRQ, it should initiate a serial poll and check the status byte. The "level uncalibrated" condition for the Signal Generator should be ignored by the system controller because this is a normal condition when the Sig-

nal Generator System is operating in the low band. The SRQ will not be re-initiated unless the condition is cleared and then reset. Therefore, the system will not drop into a continuous loop by keeping the service request active. Refer to the HP 8672A Operating and Service Manual for a complete discussion of how the Signal Generator initiates an SRQ.

e. Both the Signal Generator and the FEU make a distinction between the letter O and the number 0 (see lines 50 and 60 in the programming example). Therefore, be very careful not to inadvertently mix these two characters. However, both instruments will accept commands in either upper or lowercase letters.

f. When the system is returned to local and then back to remote, the remote vernier setting can change. To be certain the remote vernier setting is correct, always re-program the vernier setting after setting the system to remote operation.

3-14. FEU Remote Operation

The FEU can be operated through the Hewlett-Packard Interface Bus (HP-IB). Bus compatibility, operator's interface checks, programming, and data format are described in the following paragraphs.

All front panel functions (except the LINE switch) are programmable through the HP-IB. In addition, some of the functions of the FEU are controlled by the Signal Generator. Therefore, the Signal Generator must be programmed using the appropriate HP-IB command to activate these functions. For example, the 10 dB step attenuator is in the FEU but the HP-IB command to set the attenuator must be sent to the Signal Generator.

The operator's remote checks in Table 3-5 provide a test of the HP-IB to verify that the FEU can function with each of the applicable bus messages. The bus messages are described in Table 3-6.

For more information about HP-IB, refer to IEEE Std 488, ANSI Std MC1.1, the Hewlett-Packard Electronic Systems and Instruments catalog, and the booklet, "Improving Measurements in Engineering and Manufacturing" (HP part number 5952-0058).

Table 3-5. FEU Operator's Remote Checks

Set line switch to ON.

Operator's Response Check that CW, and LOCAL LEDs are lighted.

Receiving the Remote Message

Description	HP 9825A (HPL)	HP 85F (BASIC)
Send the remote message and address to listen.	rem 728	REMOTE 728

Operator's Response Check that CW, and REMOTE LEDs are lighted.

Receiving the Data Messages

Description	HP 9825A (HPL)	HP 85F (BASIC)
Program to Pulse.	wrt 728, "b0"	OUTPUT 728; "B0"

Operator's Response Check that PULSE, , and REMOTE LEDs are lighted.

Description	HP 9825A (HPL)	HP 85F (BASIC)
Program to  .	wrt 728, "b5"	OUTPUT 728; "B5"

Operator's Response Check that PULSE, , and REMOTE LEDs are lighted.

Description	HP 9825A (HPL)	HP 85F (BASIC)
Program to  .	wrt 728, "a5"	OUTPUT 728; "A5"

Operator's Response Check that PULSE, , REMOTE LEDs are lighted.

Description	HP 9825A (HPL)	HP 85F (BASIC)
Program to CW.	wrt 728, "a0"	OUTPUT 728; "A0"

Operator's Response Check that CW, and REMOTE LEDs are lighted. Press LOCAL.

Operator's Response Check that CW, and LOCAL LEDs are lighted.

Table 3-5. FEU Operator's Remote Checks (2 of 2)

Receiving the Local Lockout Message

Description	HP 9825A (HPL)	HP 85F (BASIC)
Send the remote message. Program to local lockout.	rem 728 llo 7	REMOTE 728 LOCAL LOCKOUT 7

**Operator's
Response**

Check that CW, and REMOTE LEDs are lighted. Then, press LOCAL and other keys. They should have no effect.

Receiving the Clear Lockout/Set Local

Description	HP 9825A (HPL)	HP 85F (BASIC)
Program to clear local lockout and set to local.	lcl 7	LOCAL 7

**Operator's
Response**

Check that CW, and LOCAL LEDs are lighted.

Table 3-6. HP-IB Message Reference Table for the FEU

HP-IB Message	Applicable	Response	Related Commands and Controls*	Interface Functions*
Data	Yes	All front panel functions, except LINE ON/OFF switch, are programmable. The front panel REMOTE indicator turns on when addressed.		T0, L2, AH1, SH0
Trigger	No	The FEU does not respond to the trigger message.	GET	DT0
Clear	No	The FEU does not respond to the clear message.	DCL, SDC	DC0
Remote	Yes	The FEU remote mode is enabled when the REN bus line is true. However, it remains in local (i.e., the front panel is active) until it is addressed to listen the first time. The output signal is unchanged. The front panel REMOTE indicator turns on when in remote mode.	REN	RL1**
Local	No	The FEU does not respond to the Local message. See Clear Lockout/Set Local.	GTL	RL1**
Local Lockout	Yes	LOCAL key is disabled. Only the controller can return the FEU to local.	LLO	RL1**
Clear Lockout/Set Local	Yes	FEU goes to local and local lockout is cleared when REN goes false.	REN	RL1**
Pass Control/Take Control	No	The FEU has no controller capability		C0
Require Service	No	The FEU cannot generate a service request command.	SRQ	SR0
Status Byte	No	The FEU does not respond to a serial poll.	SPE, SPD	T0
Status Bit	No	The FEU does not respond to a parallel poll.		PP0
Abort	Yes	The FEU stops listening.	IFC	T0, L2

*Commands, Control lines and Interface Functions are defined in IEEE Std 488 and ANSI Std MC1.1. Knowledge of these might not be necessary if your controller's manual describes programming in terms of the twelve HP-IB Messages shown in the left column.

**The FEU does not have complete RL1 capability since it can not process the Go-To-Local (GTL) message.

Complete HP-IB capability as defined in IEEE Std 488 and ANSI Std MC1.1 is:
SH0, AH1, T0, TE0, L2, LE0, DC0, DT0, RL1, C0, SR0, PP0.

3-15. HP-IB Compatibility

The instrument's complete bus compatibility (as defined by IEEE 488, and the identical ANSI Standard MC1.1) is described in Table 3-6. Table 3-6 also summarizes, in the left-hand column, the instrument's HP-IB capabilities in terms of the twelve bus messages. Foremost among these messages is the Data message. Data messages contain the Program Codes that control the FEU functions.

3-16. Remote Mode

Remote Capability. The FEU accepts commands from the bus in the remote mode. In remote, its front panel controls are disabled (except for the LINE switch and the LOCAL pushbutton). The LOCAL pushbutton can be disabled by a local lockout command. The FEU can be addressed to listen and when addressed to listen, it will respond to the following messages: Data, Remote, Local Lockout, Clear Lockout/Set Local, and Abort.

Local-to-Remote Mode Changes. The FEU switches to remote operation upon receipt of the Remote message. The Remote message has two parts. They are:

- a. Remote enable bus control line (REN) set true.
- b. Device listen address (MLA) received once (while REN is true).

With the exception of the FEU low-band vernier setting and the meter reading, the FEU's outputs and control settings remain unchanged with the local-to-remote transition. The REMOTE LED is on when the FEU is in the remote state. Note that the remote vernier does not retain any previous remote command. To be certain that the remote vernier setting is at the required value, the applicable Program Code must be sent each time the FEU is switched to remote.

3-17. Local Mode

Local Capability. In local, the FEU front-panel controls are fully operational and the instrument will respond to the Remote message.

Remote-to-Local Mode Changes. The FEU returns to local control upon receipt of the Clear Lockout/Set Local message. This message sets the Remote Enable control line (REN) false. If the FEU is not in Local Lockout, it switches to local

from remote when the front panel LOCAL key is pressed.

With the exception of the low-band vernier setting and the meter reading, the FEU outputs and controls remain unchanged with the remote-to-local transition. Note that the vernier setting will return to a value that is determined by the physical position of the front-panel VERNIER control.

Local Lockout. The local lockout condition disables the front panel LOCAL key. When local lockout is set, the instrument is returned to local under program control (sending Clear Lockout/Set Local) or by turning the LINE switch OFF then ON.

NOTE

Returning to local by switching to OFF then ON, will defeat the purpose of local lockout and the system controller will lose remote control of the FEU.

3-18. Addressing

The listen address is set by the slide switches on the rear panel. Refer to the paragraph on HP-IB Address Selection in Section II.

3-19. Data Messages

The state of the FEU is controlled by Data messages on the HP-IB. Data messages include the HP-IB Program Codes. The HP-IB Program Codes contains information for programming the front panel functions (except for the LINE switch). See Table 3-3 for a summary of the HP-IB Program Codes used with the FEU. The FEU receives data messages when addressed to listen.

3-20. Receiving the Data Message

The FEU responds to an alphanumeric data string such as "A12B34" when it is in the Remote state and addressed to listen. (The alpha characters in the data string can be either upper or lower case.)

3-21. Sending the Data Message

The FEU does not have the capability of sending a Data message.

3-22. Receiving the Trigger Message

The FEU does not respond to the Trigger message.

3-23. Receiving the Clear Message

The FEU does not respond to the Clear message.

3-24. Receiving the Remote Message

The Remote message causes the FEU to switch to the remote mode. The Remote message has two parts; the remote enable (REN) and address-to-listen. The operating modes do not change with the local-to-remote transition. The REMOTE LED turns on in the remote mode.

3-25. Receiving the Local Message

The FEU does not respond to the Local message. When the FEU is in remote mode, it can be returned to local mode with a Clear Lockout/ Set Local message.

The front panel LOCAL key can also return the FEU to local mode. However, pressing the LOCAL key might interrupt a data message. This would leave it in a state unknown to the controller. This situation can be avoided by setting the Local Lockout condition which disables the LOCAL key.

3-26. Receiving the Local Lockout Message

The LOCAL pushbutton switch is disabled when Local Lockout is set. The FEU is returned to local through program control by the controller.

NOTE

The FEU can also be returned to local by turning the LINE switch OFF then ON, but this defeats the purpose of the Local Lockout and the system controller loses remote control of the FEU.

3-27. Receiving the Clear Lockout/Set Local Message

The system controller sends a Clear Lockout/Set Local message to clear the Local Lockout condition and return all devices to local.

With the exception of the low-band vernier setting and the meter reading, the FEU outputs and controls remain unchanged with the remote-to-local transition. Note that the vernier setting will return to a value that is determined by the physical position of the front-panel VERNIER control.

3-28. Receiving the Pass Control Message

The FEU does not respond to the Pass Control message because it cannot act as a controller.

3-29. Sending the Require Service Message

The FEU cannot send a Require Service Message.

3-30. Sending the Status Byte Message

The FEU does not respond to a serial poll and does not send the Status Byte message.

3-31. Sending the Status Bit Message

The FEU does not respond to a parallel poll and does not send the Status Bit message.

3-32. Receiving the Abort Message

The FEU stops listening when it receives the Abort message. The Abort message is the means by which the controller sets the Interface Clear (IFC) bus line true.

3-33. SIGNAL GENERATOR SYSTEM OPERATOR'S CHECKS**3-34. Signal Generator System Local Operator's Check**

Perform the Signal Generator System Verification Test in Section IV to verify local system operation.

3-35. Signal Generator System Remote Operator's Check

Perform the following three tests to check the remote system operation:

1. Run the HP-IB Diagnostic Program for the Signal Generator. Refer the HP 8672A Operating and Service Manual.
2. Perform the operator's remote check for the FEU contained in Table 3-5.
3. Run the program shown in Table 3-4 to verify the Signal Generator System is operating as a unit.

3-36. OPERATOR MAINTENANCE

Operator maintenance is limited to replacement of the rear panel fuses. The main ac line fuse is located on the rear panel in the Line Power Module (see Figure 3-2 for the FEU and the HP 8672A Operating and Service Manual for the Signal Generator).

To remove the fuse, first remove the line power cable from its jack. Slide the fuse compartment cover to the left, then pull the handle marked FUSE PULL and remove the fuse.

WARNING

Be sure to select the correct fuse rating for the selected line voltage. Do not use repaired fuses or short circuited fuse-holders. To do so could cause a shock or fire hazard.

SECTION IV PERFORMANCE TESTS

4-1. INTRODUCTION

The procedures in this section test the Signal Generator System's electrical performance using the specifications of Table 1-1 as the performance standards. Table 4-1 summarizes the performance tests, the location of the performance tests, and the HP 8672A tests that require minor modifications. Most performance tests are contained in the HP 8672A Operating and Service Manual. All tests can be performed without access to the interior of the Signal Generator System.

NOTES

For ease of testing, the Frequency and Output Level Switching Time tests may be performed with top covers removed.

If the performance tests are to be considered valid the following conditions must be met:

a. The Signal Generator must have a 1-hour warmup.

b. The line voltage must be within +5% and -10% of nominal.

c. The ambient temperature must be +15°C to +35°C for the Output Level Flatness and RF Output Level and Accuracy tests.

Before aging rate tests are performed, the Signal Generator must 1) have a 30 day warmup if it has been disconnected from the Mains power for more than 24 hours or 2) the Signal Generator must have a 24 hour warmup if it has been disconnected from the Mains power for less than 24 hours.

4-2. EQUIPMENT REQUIRED

Equipment required for the performance tests is listed in the Recommended Test Equipment table in Section I. Any equipment that satisfies the critical specifications given in the table may be substituted for the recommended model(s). This equipment is required in addition to the equipment listed in the Recommended Test Equipment table in Section 1 of the HP 8672A Operating and Service Manual.

4-3. TEST RECORD

Results of the performance tests may be tabulated on the Test Record at the end of the procedures. The Test Record lists all of the tested specifications and their acceptable limits. This test record has been modified as required to reflect the Signal Generator System specifications. The HP 8672A test results are included to provide a complete Signal Generator System test record. The results recorded at incoming inspection can be used for comparison in periodic maintenance and troubleshooting and after repairs or adjustments.

4-4. CALIBRATION CYCLE

The Signal Generator System requires periodic verification of performance. Depending on the use and environmental conditions, the Signal Generator System should be checked using the following performance tests every six months after the first year.

4-5. ABBREVIATED PERFORMANCE TESTING

Performing the Operational Verification checks is suggested as an alternative to a complete verification of the specifications listed in Table 1-1. These checks give reasonable assurance that the Signal Generator System is performing properly.

4-6. SUMMARY OF PERFORMANCE TESTS

Table 4-1 is summary of the performance tests that are used to test the Signal Generator System's electrical characteristics. Most of these tests are contained in the HP 8672A Operating and Service Manual. The HP 8672A Performance Tests are required because the Signal Generator System specifications state that the Signal Generator System meets HP 8672A specifications except as listed in Table 1-1. In the tests where the specification is modified but the test is very similar, the difference is noted in the Comments column of the summary table. Where a new capability must be tested, the performance test is contained in this section. The Performance Test Record at the end of this section is modified to include all of the specifications that apply to the Signal Generator System. Use this table to record all performance test results.

Table 4-1. Summary of Performance Tests (1 of 2)

Performance Test	Test Procedure Location	Comments
Signal Generator System Operational Verification	Para. 4-7, this manual	
Frequency Range and Resolution	Para. 4-8, this manual	
Output Level Flatness	Refer to HP 8672A manual.	New specification added. See Table 1-1.
Harmonics and Subharmonics	Refer to HP 8672A manual.	
SWR	Refer to HP 8672A manual.	
FM Accuracy	Refer to HP 8672A manual.	
AM Distortion	Refer to HP 8672A manual.	
AM Depth, Meter Accuracy, and Input Accuracy	Refer to HP 8672A manual.	
Non-harmonically Related Spurious Signals	Refer to HP 8672A manual.	New specification added. See Table 1-1.
Power Line Related Spurious	Refer to HP 8672A manual.	New specification added. See Table 1-1. Requires a ZFM-150 mixer for the 10 MHz to 2 GHz range.
Single-sideband Phase Noise	Refer to HP 8672A manual.	New Specification added. See Table 1-1. Requires a ZFM-150 mixer for the 10 MHz 2 GHz range.
FM Frequency Response	Refer to HP 8672A manual.	New specification added. See Table 1-1.
FM Harmonic and Non-harmonic	Refer to HP 8672A manual.	New specification added. See Table 1-1. Requires a ZFM-150 mixer for the 10 MHz to 2 GHz range. Note the possibility of error in this range if a harmonic and the IF interact.
Residual FM in FM and CW Modes	Refer to HP 8672A manual.	New specification added. See Table 1-1. Requires a ZFM-150 mixer for the 10 MHz to 2 GHz range.
RF Output Level and Accuracy	Refer to HP 8672A manual.	New specification added. See Table 1-1. Requires a ZFM-150 mixer for the 10 MHz to 2 GHz range.
Incidental Phase and Frequency Modulation	Refer to HP 8672A manual.	
Frequency Switching Time	Refer to HP 8672A manual.	
Output Level Switching Time	Refer to HP 8672A manual.	

Table 4-1. Summary of Performance Tests (2 of 2)

Performance Test	Test Procedure Location	Comments
AM Rates	Refer to HP 8672A manual.	
Incidental AM	Refer to HP 8672A manual.	
Internal Time Base	Refer to HP 8672A manual.	
On/Off Ratio	Para. 4-9, this manual.	
Pulse Parameters	Para. 4-10, this manual.	

PERFORMANCE TESTS

4-7. SIGNAL GENERATOR SYSTEM OPERATIONAL VERIFICATION TEST

Equipment	Frequency Counter	HP 5343A
	Power Meter	HP 436A
	Power Sensor	HP 8481A
	Spectrum Analyzer	HP 8565A
	Diode Detector	HP 8472B
	Oscilloscope	HP 1715A
	Pulse Generator	HP 8013B

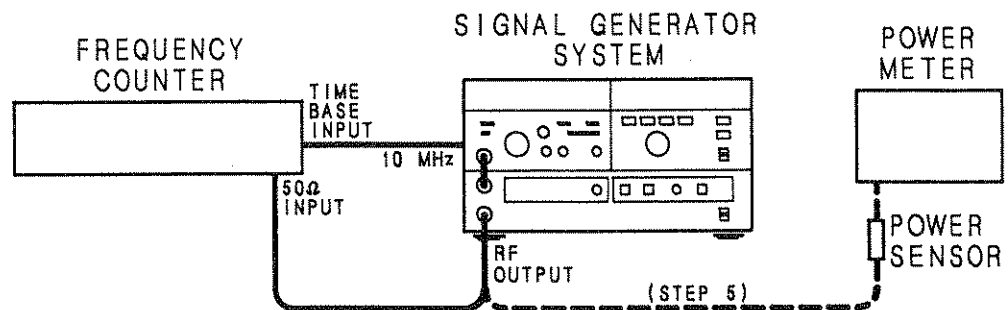

Figure 4-1. Frequency Range and Power Test Setup

Procedure

Frequency Check

1. Attach the Signal Generator's 10 MHz rear panel output to frequency counter time base input and select external time base for the counter. See Figure 4-1.
2. Attach frequency counter to the .01 TO 18.0 GHz OUTPUT connector of the FEU. Set frequency to 10 MHz on the Signal Generator. The frequency counter should read 10 MHz within the resolution of the counter.
3. Tune in 100 MHz steps from 100 MHz to 1.9 GHz while observing the actual output frequency on the counter. Accuracy matching the resolution of the counter should be maintained over the entire range.
4. Tune in 1 GHz steps from 2 to 18 GHz while observing the actual output frequency on the counter. Accuracy matching the resolution of the counter should be maintained over the entire range.

Power Check

5. Zero and calibrate the power meter. Set the cal-factor control as indicated on the power sensor for 10 MHz. Disconnect the counter and connect the power meter and sensor in its place. Set the Signal Generator System to 10 MHz at +13 dBm — that is, +10 dBm on the Signal Generator and +3 dB on the FEU. The power meter should read 13 ± 2.25 dBm.
6. Tune frequency from 100 MHz to 1.9 GHz in 100 MHz steps. If necessary reset the FEU VERNIER control to maintain a front panel meter reading of +13 dBm. The power meter reading should remain within 13 ± 2.25 dBm over the entire range.
7. Vary the FEU VERNIER control over the range of +3 to -10 dBm. The power meter reading should remain within ± 2.25 dBm of the power reading on the FEU meter.

PERFORMANCE TESTS

SIGNAL GENERATOR SYSTEM OPERATIONAL VERIFICATION TEST (cont'd)

Procedure (cont'd)

Pulse Modulation Check

8. Set the Signal Generator System to 0 dBm as displayed on the power meter and press the CW/PULSE and \square / \square keys. Power output should not change by more than 1 dB from the level set in CW.
9. Set the Signal Generator System to 10 GHz. Typically power output should not change by more than 6 dB from low band operation.
10. Set the Signal Generator System to 1 GHz at 0 dBm (with 0 dB on vernier). Attach spectrum analyzer to the FEU in place of the power meter. See Figure 4-2. Tune in the signal and set it to the top graticule line on the spectrum analyzer. Adjust spectrum analyzer bandwidth to get a noise floor on the spectrum analyzer at least 70 dB below the signal level. Use 20 dB of input attenuation on the spectrum analyzer.
11. Change the FEU to pulse \square mode. The output level should drop by at least 80 dB. Remove all input attenuation and attempt to find the reduced signal. The signal, if visible should be at least 60 dB below the top graticule line on the spectrum analyzer with the input attenuation removed.
12. Attach diode detector to the FEU's .01 TO 18.0 GHz OUTPUT connector. Attach output of the detector to oscilloscope Channel A input. Set oscilloscope impedance on Channel A to 50 ohms. Connect pulse generator output to the FEU PULSE INPUT. Connect pulse generator trigger output to oscilloscope trigger input and set oscilloscope for external trigger. Use a sweep speed of 20 ns per division on the oscilloscope. See Figure 4-2.

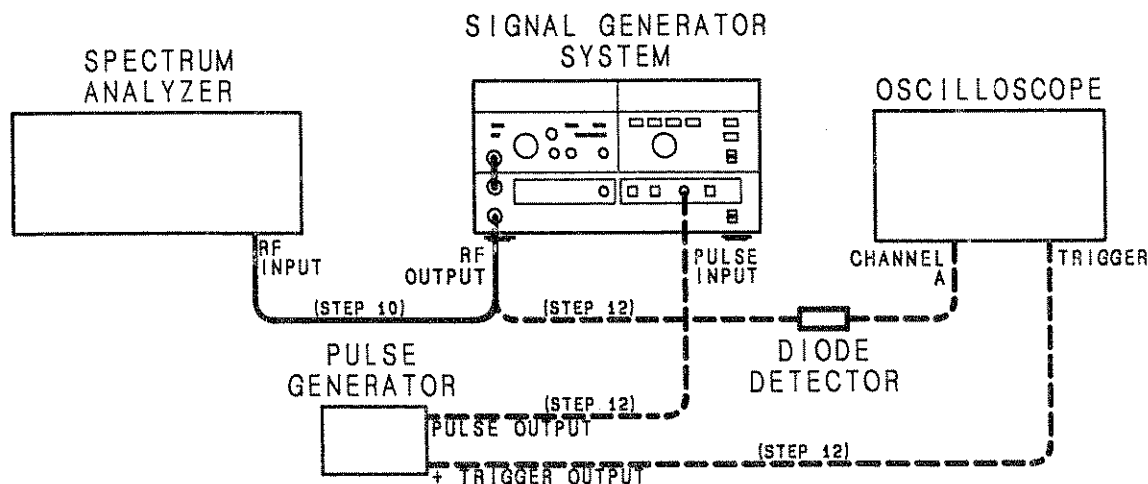

Figure 4-2. Pulse Modulation Test Setup

13. Set pulse generator for 100 ns wide pulse, minimum delay with rate fast enough to get a bright display on the oscilloscope. Measure the rise and fall times on the detected pulse from the 10% to the 90% points. The rise and fall times should be less than 15 ns.

Phase Lock Check

14. Remove 100 MHz cable on back of the FEU. The RF UNLOCK lamp should light. Reconnect the cable.

PERFORMANCE TESTS

4-8. FREQUENCY RANGE AND RESOLUTION TESTS

Specifications	Electrical Characteristics	Performance Limits	Conditions
FREQUENCY			
Range		10 MHz to 18 GHz	
Resolution		1 kHz 2 kHz 3 kHz	10 MHz to 6.2 GHz 6.2 to 12.4 GHz 12.4 to 18 GHz

Description This test checks the output frequency range and minimum resolution in each frequency band using a frequency counter. The full frequency range is further checked by tuning each frequency digit from 0 to 9 in succession.

Equipment Frequency CounterHP 5343A

Procedure 1. Connect the equipment as shown in Figure 4-3.

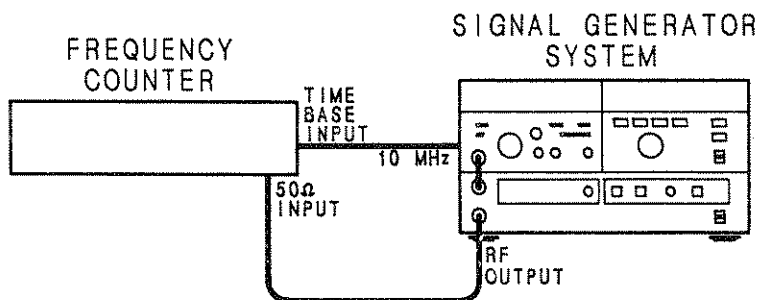

Figure 4-3. Frequency Range and Resolution Test Setup

2. Select 1 kHz display resolution and external reference on the counter.
3. Set the Signal Generator to 10 MHz and the output power to 0 dBm. The counter should read 10.000 MHz within one count.

10.000 MHz 9.999 MHz _____ 10.001 MHz

4. Set Signal Generator to 18.0 GHz. The counter should read 18.000 000 GHz within one count.

18.000 000 GHz 17.999 999 GHz _____ 18.000 001

5. Set Signal Generator to any other frequency of interest and check counter reading. All readings should be within one count of the Signal Generator setting.

Frequency Reading

PERFORMANCE TESTS

FREQUENCY RANGE AND RESOLUTION TESTS (cont'd)**Procedure
(cont'd)**

6. Set the Signal Generator to 2.0 GHz. Change frequency in 1 kHz steps while observing the counter. Verify that the Signal Generator output frequency is within one count on the counter.

2.0 GHz, 1 kHz Resolution _____ (✓)

7. Repeat step 6 in the frequency bands listed in the specifications, with the increments listed.

8.0 GHz, 2 kHz Resolution _____ (✓)

14.0 GHz, 3 kHz Resolution _____ (✓)

8. Set the Signal Generator frequency to 1.0 GHz. Starting with maximum frequency resolution, step the 1 kHz from 0 to 9, ensuring that the frequency is accurate within one count on the counter, and the Signal NOT PHASE LOCKED front panel LED remains off at all settings.

NOTE

Fast tuning of frequency with the TUNING control may cause the NOT PHASE LOCKED LED to momentarily flash on. This is normal, and does not indicate a malfunction.

1.000 000 GHz to 1.000 009 GHz _____ (✓)

9. Change resolution as required and check the next frequency digit from 0 to 9. Check frequency accuracy at each step.

1.000 009 GHz to 1.000 099 GHz _____ (✓)

1.000 099 GHz to 1.000 999 GHz _____ (✓)

1.000 999 GHz to 1.009 999 GHz _____ (✓)

1.009 999 GHz to 1.099 999 GHz _____ (✓)

1.099 999 GHz to 1.999 999 GHz _____ (✓)

10. Set the frequency to 2 GHz and step the digits from 2 to 18, ending at 18.000 000 GHz, checking the frequency at each step for accuracy of ± 1 kHz.

2.000 000 GHz to 18.000 000 GHz _____ (✓)

PERFORMANCE TESTS

4-9. ON/OFF RATIO TEST

Specification On/Off Ratio: >80 dB.

Description A spectrum analyzer is used to measure the change in power output when the pulse modulation is switched from normal (□) to complement mode (◻).

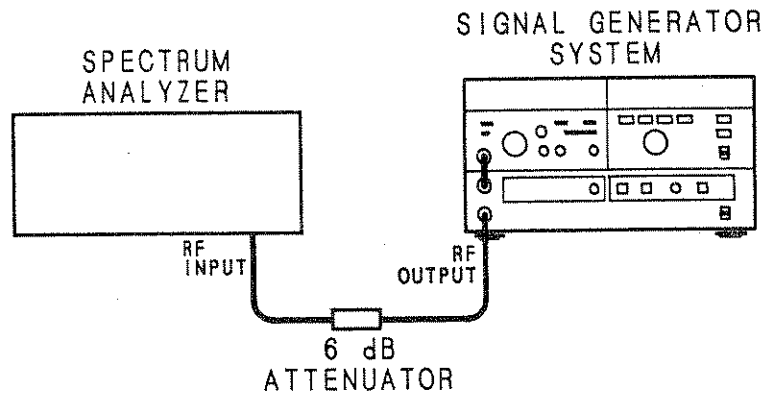

Figure 4-4. On/Off Ratio Test Setup

Equipment 6 dB Attenuator HP 8491B Option 006
Spectrum Analyzer HP 8565A

- Procedure**
1. Set Signal Generator to 14 GHz or any other frequency of interest. Set power output to about +3 dBm with modulation off.
 2. Connect equipment as shown in Figure 4-4.
 3. Press CW/PULSE. Verify that PULSE, □, and LOCAL LEDs are lit. Press □ / ◻ and verify ◻ LED lights.
 4. Adjust spectrum analyzer to establish a reference signal at the top graticule line. Use at least 40 dB of input attenuation and a band width of 1 kHz or less.
 5. Press □ / ◻. Verify □ lights.
 6. Reduce spectrum analyzer reference level as needed to observe the residual signal. It should be >80 dB below the reference established in step 4.

PERFORMANCE TESTS

4-10. PULSE PERFORMANCE TEST

Specifications Rise and Fall Times: <15 ns.
Peak Pulse Power: Within 1.0 dB of level selected in CW mode in low band. Uncalibrated in high band.

Description The RF output pulse is detected and displayed on the oscilloscope. The performance parameters are observed directly.

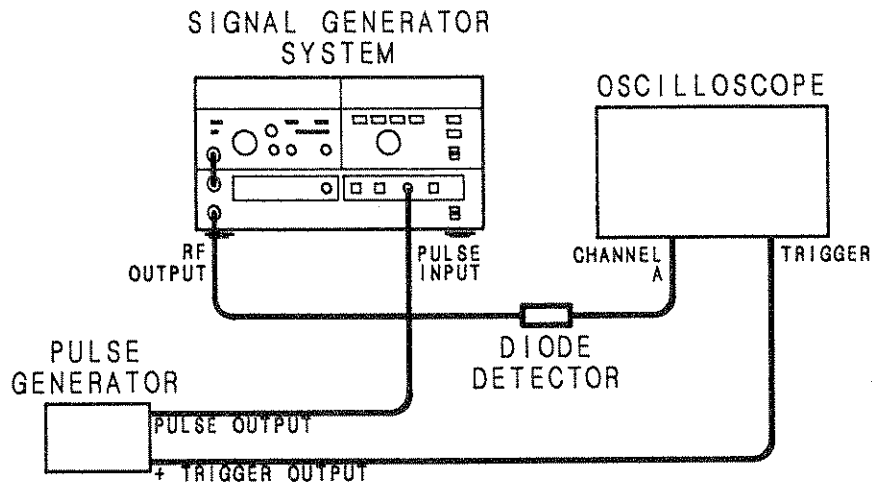

Figure 4-5. Pulse Performance Test Setup

Equipment	Diode Detector	HP 8472B
	Pulse Generator	HP 8013B
	Oscilloscope	HP 1715A

- Procedure**
1. Set the Signal Generator to 1 GHz at +3 dBm with modulation off.
 2. Set the pulse generator to the following settings:

Pulse Period Range	20 ns-1 μ s
Pulse Delay Range	35 ns-1 μ s
Pulse Width Range	0 ns-1 μ s
Pulse Double/Norm	Norm
Output Norm/Compl	Norm
Amplitude Range	4-10 Vpk
Offset (+Output)	Off
Int Load	Out
 3. Set the pulse generator's amplitude for 5 Vpk signal, the pulse period to 1 μ s, and the pulse width to approximately 200 ns using the waveform displayed on the oscilloscope.
 4. Connect equipment as shown in Figure 4-5. Press CW/PULSE. Verify that PULSE, , and LOCAL LED's are lit.

PERFORMANCE TESTS

PULSE PERFORMANCE TEST (cont'd)

Procedure (cont'd)

5. Refer to Figure 4-6 and measure rise time (A) and fall time (B).

Rise Time _____ < 15 ns (A) (10 to 90%)

Fall Time _____ < 15 ns (D) (10 to 90%)

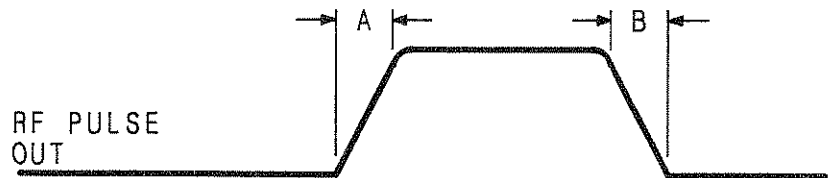

Figure 4-6. Pulse Performance Parameters

6. Adjust the oscilloscope vertical position and sensitivity controls so that the pulse baseline is one division from the bottom graticule line and approximately 5 divisions high in peak amplitude.
7. Switch the FEU to CW mode.
8. Adjust the oscilloscope vertical sensitivity for a display 5 divisions above the pulse baseline. The peak of the CW signal is now the CW peak reference level.

NOTE

Do not touch the vertical position controls after the the CW peak reference level has been set.

9. Switch back to pulse mode. Without touching the vertical sensitivity controls, measure the difference between the CW peak reference level and the average peak pulse level excluding any over/undershoot. See Figure 4-7.

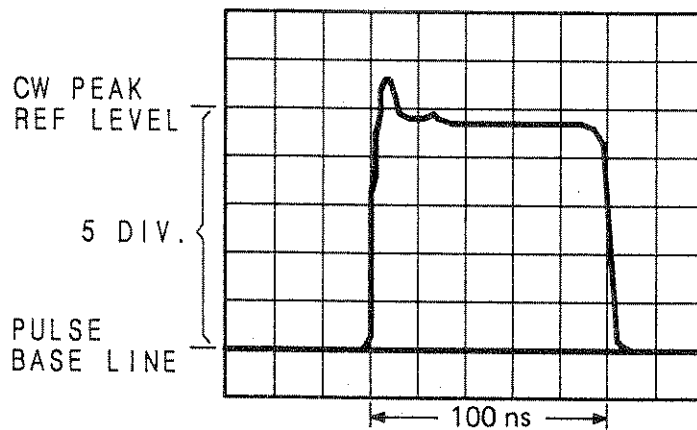

Figure 4-7. Pulse Accuracy Measurement

PERFORMANCE TESTS

PULSE PERFORMANCE TEST (cont'd)

**Procedure
(cont'd)**

10. The error can be read in percent. Using a 5 division peak reference, each division represents 20% of error. The measured error must be within the limits of -8.9% to +12.2% (-8.9% corresponds to -0.45 divisions on oscilloscope; +12.2% corresponds to +0.61 divisions). These error limits are equal to ± 1 dB.

-8.9% _____ +12.2%

11. Repeat steps 5 through 10 at 3 GHz and 17 GHz.

3 GHz -8.9% _____ +12.2%

17 GHz -8.9% _____ +12.2%

Table 4-2. Performance Test Record (1 of 5)

Hewlett-Packard Company Model 8672S Synthesized Signal Generator System Serial Number _____		Tested by _____ Date _____		
Para. No.	Test	Results		
		Min.	Actual	Max.
4-7.	SIGNAL GENERATOR SYSTEM VERIFICATION Passed		_____ (✓)	
4-8.	FREQUENCY RANGE AND RESOLUTION			
	Range			
	10.000 MHz	9.999	_____	10.001
	18.000 000 GHz	17.999.999	_____	18.000 001
	Resolution			
	2.0 GHz	1.999 999	_____	2.000 001
8.0 GHz	7.999 999	_____	8.000 001	
14.0 GHz	14.999 999	_____	14.000 001	
	All digits displayed		_____ (✓)	
*	OUTPUT LEVEL FLATNESS			
	Total Variation			
	2.0—6.2 GHz ±1.00 dB		_____	2.00 dB
	2.0—12.4 GHz ±1.25 dB		_____	2.50 dB
	2.0—18.0 GHz ±1.50 dB		_____	3.00 dB
*	HARMONICS AND SUBHARMONICS			
	Ratio of Harmonics and Subharmonics Amplitude to Carrier Amplitude, 25 dB minimum			
	Fundamental Harmonic or Subharmonic			
	2000 MHz 2f 4000 MHz	25 dB	_____	
	3000 MHz 2f 6000 MHz	25 dB	_____	
	2000 MHz 3f 6000 MHz	25 dB	_____	
	8266.668 MHz 1/2f 4133.334 MHz	25 dB	_____	
	12 400.002 MHz 1/3f 4133.334 MHz	25 dB	_____	
	12 400.002 MHz 2/3f 8266.668 MHz	25 dB	_____	
*	SWR			
	3 GHz SWR <2.50		_____ (✓)	
	6 GHz SWR <2.50		_____ (✓)	
	9 GHz SWR <2.50		_____ (✓)	
	12 GHz SWR <2.50		_____ (✓)	
	15 GHz SWR <2.50		_____ (✓)	
	18 GHz SWR <2.50		_____ (✓)	
*	FM ACCURACY			
	at 100 kHz rate Meter accuracy ±10%	210	_____	270 kHz-pk
	Accuracy relative to input level ± 7%	0.53	_____	0.61 Vrms
*These test procedures are in the HP 8672A Operating and Service Manual				

Table 4-2. Performance Test Record (2 of 5)

Para. No.	Test	Results		
		Min.	Actual	Max.
*	AM DISTRIBUTION for rates <10 kHz 30% AM Depth <3% 50% AM Depth <4% 75% AM Depth <5%		_____	3% 4% 5%
*	AMPLITUDE MODULATION DEPTH, METER ACCURACY AND INPUT ACCURACY Detected AM Signal 75% AM 140 60% AM 110 50% AM 90 30% AM 57 AM Drive Signal 75% AM 460 60% AM 354 50% AM 283 30% AM 636		_____	160 mVrms 130 mVrms 110 mVrms 63 mVrms 601 mVrms 495 mVrms 424 mVrms 778 mVrms
*	NON-HARMONICALLY RELATED SPURIOUS SIGNALS 10 MHz to 2.0 GHz <-60 2.0 to 6.2 GHz <-70 dB	60 dB down 70 dB down	_____ (✓) _____ (✓)	
*	POWER LINE RELATED SPURIOUS F _c = 10 MHz to 6.2 GHz f _o <300 Hz -50 dBc 50 dB down 300 Hz ≤ f _o ≤ 1 kHz -60 dBc 60 dB down f _o >1 kHz -65 dBc 65 dB down F _c = 6.2 MHz to 12.4 GHz f _o <300 Hz -44 dBc 44 dB down 300 Hz ≤ f _o ≤ 1 kHz -54 dBc 54 dB down f _o >1 kHz -59 dBc 59 dB down F _c = 12.4 MHz to 18.0 GHz f _o <300 Hz -40 dBc 40 dB down 300 Hz ≤ f _o ≤ 1 kHz -50 dBc 50 dB down f _o >1 kHz -55 dBc 55 dB down		_____	
*	SINGLE-SIDEBAND PHASE NOISE RATIO SSB level in 1 Hz BW mode at specified offset frequencies 10 MHz to 6.2 GHz 10 Hz -58 dBc 54.8 dB down 100 Hz -70 dBc 62.0 dB down 1 kHz -78 dBc 60.0 dB down 10 kHz -86 dBc 58.0 dB down 100 kHz -110 dBc 72.0 dB down (continued)		_____	
*These test procedures are in the HP 8672A Operating and Service Manual				

Table 4-2. Performance Test Record (3 of 5)

Para. No.	Test	Results				
		Min.	Actual	Max.		
*	SINGLE—SIDEBAND PHASE NOISE RATIO (cont'd)					
	6.2 to 12.4 GHz	10 Hz	-52 dBc	48.8 dB down	_____	
		100 Hz	-64 dBc	56.0 dB down	_____	
		1 kHz	-72 dBc	54.0 dB down	_____	
		10 kHz	-80 dBc	52.0 dB down	_____	
		100 kHz	-104 dBc	66.0 dB down	_____	
	12.4 to 18.0 GHz	10 Hz	-48 dBc	44.8 dB down	_____	
		100 Hz	-60 dBc	52.0 dB down	_____	
		1 kHz	-68 dBc	50.0 dB down	_____	
		10 kHz	-76 dBc	48.0 dB down	_____	
		100 kHz	-100 dBc	62.0 dB down	_____	
*	FM FREQUENCY RESPONSE					
	Relative to 100 kHz rate					
		±2.0 dB	3 kHz	-2.0 dB	_____	+2.0 dB
			30 kHz	-2.0 dB	_____	+2.0 dB
			300 kHz	-2.0 dB	_____	+2.0 dB
			1000 kHz	-2.0 dB	_____	+2.0 dB
			3000 kHz	-2.0 dB	_____	+2.0 dB
*	FM HARMONIC & NON-HARMONIC DISTORTION					
	<3 kHz		<12%		_____	12%
	20 kHz to 100 Hz		≤5%		_____	5%
*	RESIDUAL FM IN FM AND CW MODES					
	300 Hz — 3 kHz Post Detection Bandwidth					
	10.0 MHz to 6.199 GHz				_____	16 Hz-rms
	6.200 to 12.399 GHz				_____	32 Hz-rms
	12.400 to 18.000 GHz				_____	48 Hz-rms
	50 Hz—15 kHz Post Detection Bandwidth					
	10.0 MHz to 6.199 GHz				_____	80 Hz-rms
	6.200 to 12.399 GHz				_____	160 Hz-rms
	12.400 to 18.000 GHz				_____	240 Hz-rms
*	RF OUTPUT LEVEL AND ACCURACY					
	10.0 MHz ≤ f ₀ < 2.0 GHz					
	13 dBm range	±2.25 dB		10.75	_____	+15.25 dBm
	0 dBm range	±2.25 dB		-2.25	_____	+2.25 dBm
	-10 dBm range	±2.75 dB		-12.75	_____	-7.25 dBm
	-20 dBm range	±2.95 dB		-22.95	_____	-17.05 dBm
	-30 dBm range	±3.15 dB		-33.15	_____	-26.85 dBm
	-40 dBm range	±3.45 dB		-43.45	_____	-36.55 dBm
	-50 dBm range	±3.75 dB		-53.75	_____	-46.25 dBm
	-60 dBm range	±4.05 dB		-64.05	_____	-55.95 dBm
*These test procedures are in the HP 8672A Operating and Service Manual						

Table 4-2. Performance Test Record (4 of 5)

Para. No.	Test	Results		
		Min.	Actual	Max.
*	RF OUTPUT LEVEL AND ACCURACY (cont'd)			
	2.0 GHz \leq f_o < 6.2 GHz			
	0 dBm range ± 2.00 dB	-2.00	_____	+2.00 dBm
	-10 dBm range ± 2.50 dB	-12.50	_____	-7.50 dBm
	-20 dBm range ± 2.70 dB	-22.70	_____	-17.30 dBm
	-30 dBm range ± 2.90 dB	-32.90	_____	-27.10 dBm
	-40 dBm range ± 3.20 dB	-43.20	_____	-36.80 dBm
	-50 dBm range ± 3.50 dB	-53.50	_____	-46.50 dBm
	-60 dBm range ± 3.80 dB	-63.80	_____	-56.20 dBm
	6.2 GHz \leq f_o < 12 GHz			
	0 dBm range ± 2.25 dB	-2.25	_____	+2.25 dBm
	-10 dBm range ± 2.75 dB	-12.75	_____	-7.25 dBm
	-20 dBm range ± 2.95 dB	-22.95	_____	-17.05 dBm
	-30 dBm range ± 3.15 dB	-33.15	_____	-26.95 dBm
	-40 dBm range ± 3.45 dB	-43.45	_____	-36.55 dBm
	-50 dBm range ± 3.75 dB	-53.75	_____	-46.25 dBm
	-60 dBm range ± 4.05 dB	-64.05	_____	-55.95 dBm
	12.4 GHz \leq f_o < 18 GHz			
	0 dBm range ± 2.50 dB	-2.50	_____	+2.50 dBm
	-10 dBm range ± 3.10 dB	-13.10	_____	-6.90 dBm
	-20 dBm range ± 3.30 dB	-23.30	_____	-16.70 dBm
	-30 dBm range ± 3.70 dB	-33.70	_____	-26.30 dBm
	-40 dBm range ± 4.10 dB	-44.10	_____	-35.90 dBm
	-50 dBm range ± 4.50 dB	-54.50	_____	-45.50 dBm
	-60 dBm range ± 4.90 dB	-64.90	_____	-55.10 dBm
	Following levels relative to -60 dBm level			
	2.0 GHz \leq f_o \leq 6.2 GHz			
	-70 dBm range	9.7	_____	10.3 dB down
	-80 dBm range	19.4	_____	20.6 dB down
	-90 dBm range	29.1	_____	30.9 dB down
	-100 dBm range	38.8	_____	41.2 dB down
	-110 dBm range	48.5	_____	51.5 dB down
	6.2 GHz \leq f_o \leq 12.4 GHz			
	-70 dBm range	9.7	_____	10.3 dB down
	-80 dBm range	19.4	_____	20.6 dB down
	-90 dBm range	29.1	_____	30.9 dB down
	-100 dBm range	38.8	_____	41.2 dB down
	-110 dBm range	48.5	_____	51.5 dB down
	12.4 GHz \leq f_o \leq 18.0 GHz			
	-70 dBm range	9.6	_____	10.4 dB down
	-80 dBm range	19.2	_____	20.8 dB down
	-90 dBm range	28.8	_____	31.2 dB down
	-100 dBm range	38.4	_____	41.6 dB down
	-110 dBm range	48.0	_____	52.0 dB down
*These test procedures are in the HP 8672A Operating and Service Manual				

SECTION V ADJUSTMENTS

5-1. INTRODUCTION

This section contains adjustments and checks that assure peak performance of the Signal Generator System. This system should be readjusted after repair or failure to pass a performance test. Allow a 30 minute warm-up prior to performing the adjustments.

The order in which the adjustments are made is critical. Prior to making any adjustments, refer to the paragraph entitled Related Adjustments.

Determining the adjustments to be performed after a component failure and subsequent repair or a performance test failure is important. This will help keep the adjustment time to a minimum. After the repair and/or adjustment, performance tests are usually required to verify proper performance. Refer to the paragraph entitled Related Adjustments.

5-2. SAFETY CONSIDERATIONS

This section contains information, cautions and warnings which must be followed for your protection and to avoid damage to the equipment.

WARNING

Maintenance described in this section is performed with power supplied to the instrument and with protective covers removed. Maintenance should be performed only by service trained personnel who are aware of the hazard involved (for example, fire and electrical shock). Where maintenance can be performed without power applied, the power should be removed.

5-3. EQUIPMENT REQUIRED

Each adjustment procedure contains a list of

required test equipment and accessories. The test equipment is identified by callouts in the test setup diagrams included with each procedure.

If substitutions must be made for the specified test equipment, refer to Table 1-5 for the minimum specifications. It is important that the test equipment meet the critical specifications listed in the table if the Signal Generator System is to meet its performance requirements.

5-4. FACTORY SELECTED COMPONENTS

Factory selected components are identified on the schematics and parts list by an asterisk which follows the reference designator. The normal value or range of the components are shown. The manual change sheets will provide updated information pertaining to the selected components. Table 5-1 lists the reference designator, the criterion used for selecting a particular value, the normal value range, and the service sheet where the component part is shown.

5-5. RELATED ADJUSTMENTS

If all the adjustments are to be performed, the HP 8672A Synthesized Signal Generator adjustments should be done first. These adjustments are contained in the HP 8672A Operating and Service Manual.

The FEU low band adjustment should be performed prior to any other adjustment. The remaining adjustments can be performed in any order as they are not interdependent.

After the instrument is repaired and/or adjusted, performance test(s), a frequency check and verification of phase lock or all of these things must be done to verify proper performance of the Signal Generator. Refer to the HP 8672A Operating and Service Manual for additional information.

Table 5-1. Factory Selected Components

Reference Designator	Service Sheet	Range of Values	Basis of Selection
A1R18	4	562 to 1800Ω	Improve rise and fall time at 18 GHz.

ADJUSTMENTS

5-6. LOW BAND ADJUSTMENTS (10 MHz to 2 GHz)

Reference Service Sheets 6 and 7.

Description Adjust low band components to optimize the ALC and the meter drive circuits.

Equipment

Digital Voltmeter	HP 3455A
HP-IB Controller	HP 85F
Power Meter	HP 436A
Power Sensor	HP 8481A

CAUTION

If power is applied to the FEU when A10R109 (MW) is completely CCW, transistor Q11 can be damaged.

Procedure

1. Center the following adjustments in the FEU:
 - a. A10R109 (MW)
 - b. A10R13 (IOS)
 - c. A10R58 (IOFFS)
2. Adjust the mechanical control on the FEU to set the needle about 1/8 inch below -10dBm.

NOTE

In this procedure, only the FEU is connected to the HP-IB controller. This test setup is used to reduce the number of command entries required to perform the FEU adjustments.

3. Connect equipment as shown in Figure 5-1 and apply power.

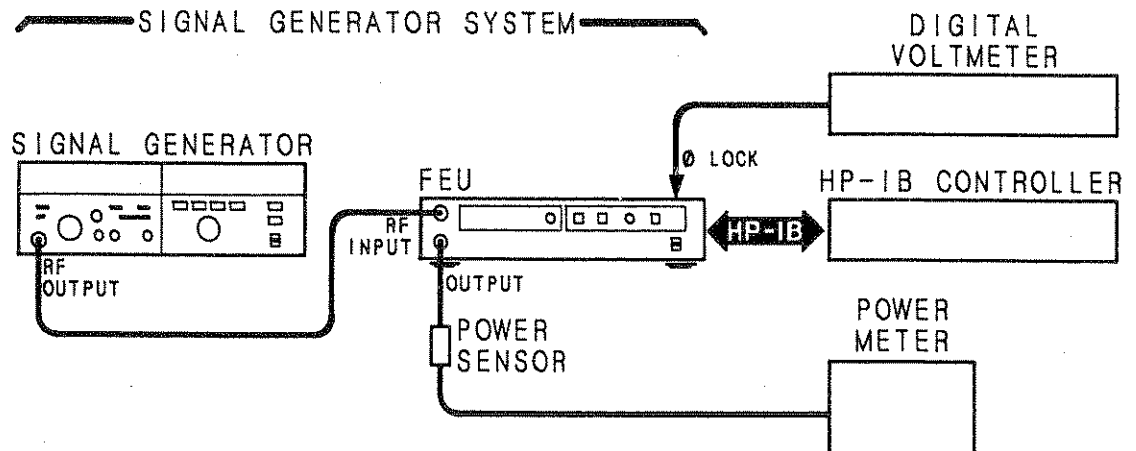

Figure 5-1. Low Band Adjustment Setup

ADJUSTMENTS

5-6. LOW BAND ADJUSTMENTS (10 MHz to 2 GHz) (cont'd)

Procedure (cont'd)

4. Connect digital voltmeter to A9TP1 on the ALC Power Supply board. Adjust A9R11 for -10 ± 0.005 Vdc reading.
5. Connect digital voltmeter to A9TP2. Adjust A9R4 for $+20 \pm 0.005$ Vdc reading. This completes the ALC power supply adjustments.

NOTE

In the following steps, make sure the voltmeter GUARD is released. The voltage in step 6 is not critical and will change slightly depending upon temperature.

6. Connect voltmeter to the ϕ LOCK test point on the 4.2 GHz local oscillator. Adjust the oscillator tuning screw (under the attenuator) for an 8.0 ± 0.4 Vdc reading.
7. Set the Signal Generator to 300 MHz at 0 dBm. Set the OUTPUT VERNIER on the FEU fully CCW.
8. Connect voltmeter to A10TP4 and verify the voltage reading is -6.2 Vdc ± 30 mVdc. Record the reading.

_____ Vdc

NOTE

Before programming any specific commands, be sure the FEU is in the remote enabled mode.

9. Program the FEU vernier to -12 dBm by sending the the program string "A1234".
10. Adjust A10R35 (0dB) for the same voltage reading recorded in step 8 (± 1 mVdc).
11. Connect the voltmeter between A10TP2 and A10R4 (51.1 ohms) as shown in Figure 5-2.
12. Adjust A10R13 (IOS) for a voltage reading of 0 ± 10 μ vdc.
13. Set the Signal Generator RF OUTPUT switch ON.
14. Connect the voltmeter to A10TP5. Adjust A10R58 (IOFFS) for a voltage reading of 130 ± 1 mVdc.
15. Set the Signal Generator RF OUTPUT switch OFF. Verify the FEU LVL UNCAL indicator lights.

NOTE

Steps 16 and 17 calibrate the front panel meter. They do not change the power output.

16. Program the FEU vernier to -10 dBm by sending the string "A134B2". Adjust A10R115 (MZ) to set the meter to -10 dBm.
-

ADJUSTMENTS

5-6. LOW BAND ADJUSTMENTS (10 MHz to 2 GHz) (cont'd)

Procedure (cont'd)

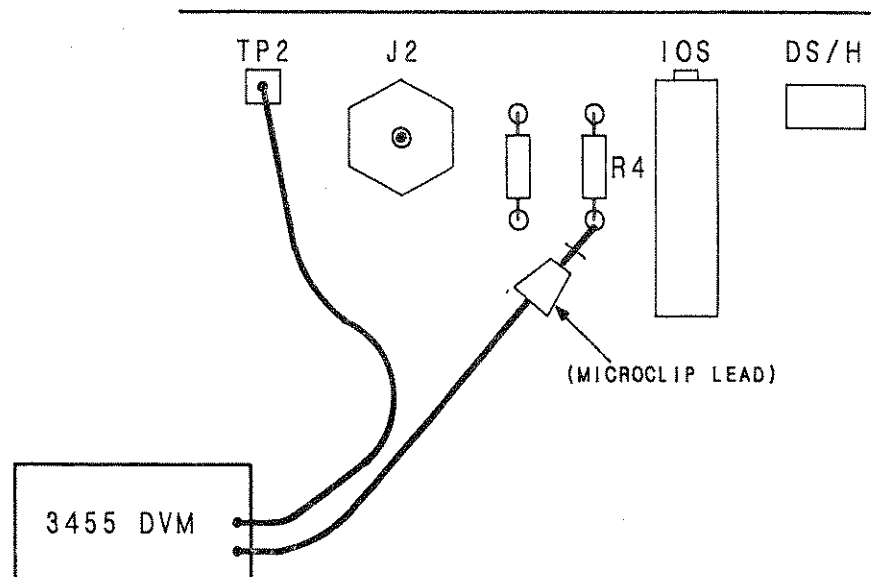

Figure 5-2. Voltmeter Connection

17. Program the FEU vernier to 0 dBm by sending the program string "A12B34". Adjust A10R119 (MG) to set the meter to 0 dBm.
18. Repeat steps 16 and 17 until no further adjustment is necessary.
19. Program the FEU vernier to +1 dBm by sending the program string "A2B134".
20. Adjust A10R27 (+1) for a power reading of $+1.00 \pm 0.02$ dBm on the power meter.
21. Program the FEU vernier to -6 dBm by sending the program string "A14B23".
22. Adjust A10R37 for a power reading of -6 ± 0.02 dBm.
23. Repeat steps 19 through 22 until less than ± 0.1 dBm improvement is obtained with each successive adjustment.
24. Set the Signal Generator to the + 10 dBm range.
25. Program the FEU vernier to -6 dBm by sending the program string "A14B23". Adjust A10R62 (+4) for a power reading of $+4 \pm 0.02$ dBm.
26. Program the FEU vernier to +2 dBm by sending program string "A1B234". Adjust A10R22 (+12) for a power reading of $+12 \pm 0.02$ dBm.
27. Repeat steps 25 and 26 until less than ± 0.1 dBm improvement is obtained on each successive adjustment.



ADJUSTMENTS

5-6. LOW BAND ADJUSTMENTS (10 MHz to 2 GHz) (cont'd)**Procedure
(cont'd)**

28. Set the Signal Generator to 0 dBm and repeat steps 19 through 27 until less than ± 0.1 dBm improvement is obtained on each successive adjustment.
29. Press LOCAL on the FEU and verify the LOCAL indicator lights. Set the OUTPUT VERNIER for a power reading of 0.5 dBm on the FEU front panel meter.

CAUTION

Do not adjust A10R109 (MW) completely CCW as this can cause damage to transistor Q11.

30. Connect the voltmeter to A10TP7. Adjust A10R109 (MW) for a voltage reading of 0.0 ± 5 mVdc.
31. Connect the voltmeter to A10TP1. Adjust A10R32 (DRF) for a voltage reading of 3.0 Vdc ± 5 mVdc.
32. Verify the CW LED on the FEU is lit. Adjust the OUTPUT VERNIER for a 0 dBm reading on the power meter. Record the output power (it should be very close to zero).
_____ 0 dBm
33. Press CW/PULSE and then  / . Verify the PULSE and  LEDs are lit.
34. Adjust A10R91 (DS/H) for the same power reading recorded in step 32 (± 0.1 dBm).

ADJUSTMENTS

5-7. PULSE OFFSET ADJUSTMENT

Reference	Service Sheet 5.
Description	Using an ammeter, the current through the modulator is adjusted.
Equipment	Current Measuring Adapter See Figure 5-3 Digital Multimeter HP 3455A
Procedure	1. Disconnect cable W18 at jack A1J2. Insert a locally fabricated current measurement adapter (see Figure 5-3) between cable W18 and A1J2. Connect the digital multimeter to the center conductor leads of the adapter and set the multimeter to read current.

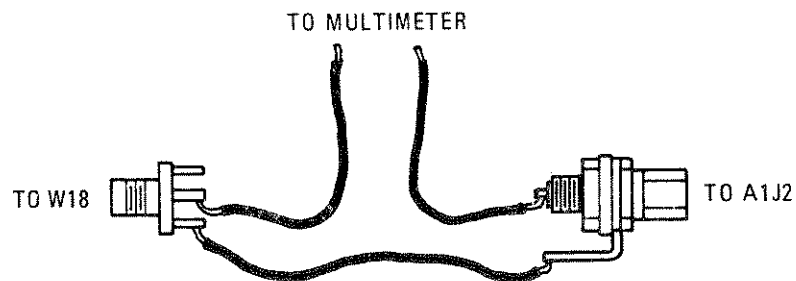

SMC MALE P.C. CONNECTOR	HP 1250-0835
SMC FEMALE CONNECTOR	HP 1250-0880
SOLDER LUG, #10	HP 0360-0452

Figure 5-3. Current Measuring Adapter

2. Connect system to mains. Set POWER switches ON, frequency to above 3 GHz, and pulse mode to \square (complementary).
3. Adjust A1R30 (OS) to obtain a modular current of 46 mA.
4. Set pulse mode switch to \square (normal). The current should be between -75 and -95 mA. This is a check only, there is no adjustment.
5. Reconnect cable W18 to jack A1J2.

ADJUSTMENTS

5-8. RISE AND FALL TIME ADJUSTMENT

Reference Service Sheet 5.

Description The timing of the Turn-On and Turn-Off Monostable flip flops is adjusted while observing their outputs on an oscilloscope. The rise and fall time adjustments are then optimized while observing the RF output pulse on the oscilloscope.

Equipment
 Diode Detector HP 8472A
 Oscilloscope HP 1715A
 Pulse Generator HP 8013B

Procedure 1. Connect equipment as shown in Figure 5-4 leaving the Signal Generator's output disconnected.

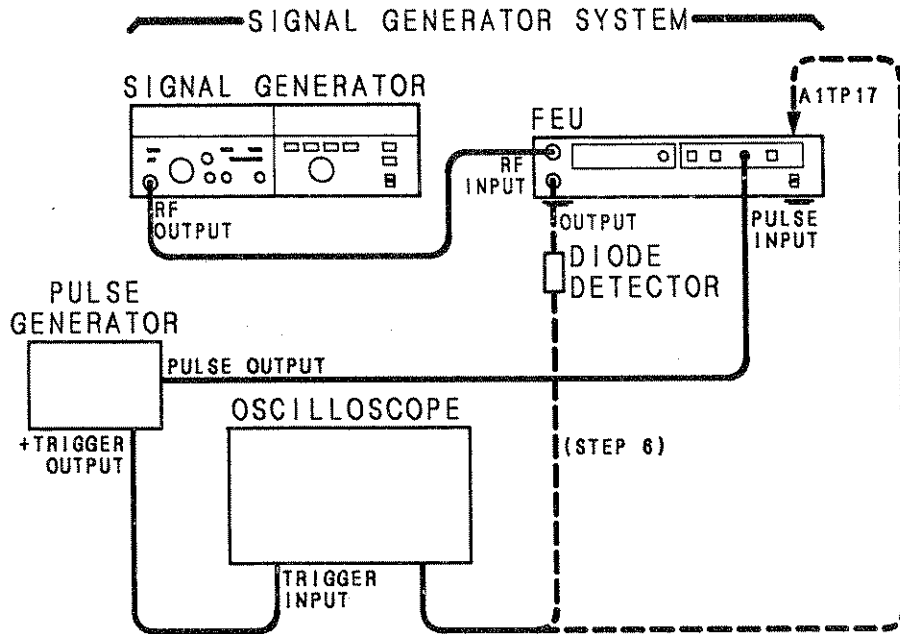

Figure 5-4. Rise and Fall Time Adjustments Setup

2. Set the pulse generator to the following settings:

Pulse Period Range	20ns-1 μ s
Pulse Delay Range	35ns-1 μ s
Pulse Width Range	10ns-1 μ s
Pulse Double/Norm	Norm
Output Norm/Compl	Norm
Amplitude Range	4-10 Vpk
Offset(+Output)	Off
Int Load	Out

3. Connect the oscilloscope to A1TP17 using a 10:1 high frequency probe. Set oscilloscope to 0.2 volts/division and the proper sweep speed to display the waveform.

ADJUSTMENTS

5-8. RISE AND FALL TIME ADJUSTMENT (cont'd)

Procedure (cont'd)

4. Set potentiometer A1R14 (+PW) fully clockwise. Adjust counterclockwise to obtain the bias pulse waveform shown in Figure 5-5.

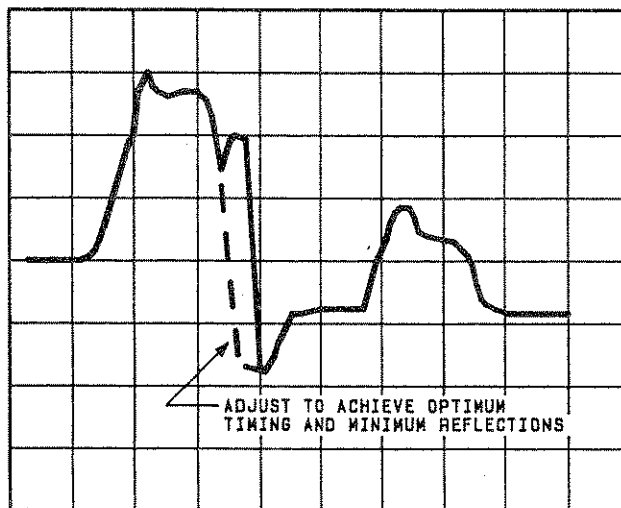

Figure 5-5. Bias Pulse Adjustment Waveform

5. Set potentiometers A1R7 (-P) and A1R12 (-PW) to the center of their ranges. Adjust A1R12 (-PW) for a pulse width of 7 ns on the negative pulse at A1TP17.
6. Connect oscilloscope and diode detector to the .01 TO 18.0 GHz OUTUT of the FEU. Set pulse generator's pulse width to about 100 ns.
7. Set Signal Generator to 3 GHz.
8. Set FEU pulse mode to \square (normal).
9. Adjust potentiometer A1R7, "-P", for the shortest RF pulse fall time.
10. Verify that the rise and fall times are less than than 15 ns.
11. Set Signal Generator to 18 GHz and verify the rise and fall times are as before. If the rise time is greater than 15 ns, change A1R18 to 1800 ohms. Readjust the "+PW" potentiometer as in step 4 and repeat the rise time test. Verify that no power dip in RF pulse waveform occurs with the new resistor.

SECTION VI REPLACEABLE PARTS

6-1. INTRODUCTION

This section contains information for ordering replacement parts for the Frequency Extension Unit. Table 6-1 and 6-2 list abbreviations used in the parts list and throughout the manual. Table 6-3 lists all replaceable parts in reference designator order. Table 6-4 contains the names and addresses that correspond to the manufacturer's code numbers.

6-2. ABBREVIATIONS

Table 6-1 reference designations. Table 6-2 lists abbreviations used in the parts list, schematics, and throughout the manual. In some cases, two forms of the abbreviation are used, one all in capital letters, and one partial or no capitals. This occurs because the abbreviations in the parts list are always all capitals. However, in the schematics and other parts of the manual, other abbreviation forms are used with both lower case and upper case letters.

6-3. REPLACEABLE PARTS LIST

Table 6-3 is the list of replaceable parts and is organized as follows:

- a. Electrical assemblies and their components in alphanumeric order by reference designation.
- b. Chassis-mounted parts in alphanumeric order by reference designation.
- c. Mechanical parts.
- d. Illustrated parts breakdown.

The information given for each part consists of the following:

- a. The Hewlett-Packard part number.
- b. Part number check digit (CD).
- c. Total quantity (Qty) used in the instrument.
- d. Part description.
- e. Five-digit code that represents a typical manufacturer.

- f. Manufacturer's part number.

6-4. ORDERING INSTRUCTION

To order a part listed in the replaceable parts table, include the Hewlett-Packard part number (with the check digit), and the quantity required. Address the order to the nearest Hewlett-Packard office. The check digit will ensure accurate and timely processing of your order.

To order a part that is not listed in the replaceable parts table, include the instrument model number, instrument serial number, description and function of the part, and the number of parts required. Address the order to the nearest Hewlett-Packard office.

NOTE

Within the USA, it is better to order directly from the HP Parts Center in Mountain View, California. Ask your nearest HP office for information and forms for the "Direct Mail Order System".

6-5. RECOMMENDED SPARES LIST

Stocking spare parts for an instrument is often done to ensure quick return to service after a malfunction occurs. Hewlett-Packard prepares a "Recommended Spares" list for this instrument. The contents of the list are based on failure reports and repair data. Quantities given are for one year of parts support. A complimentary copy of the "Recommended Spares" list may be requested from your nearest Hewlett-Packard office.

When stocking parts to support more than one instrument or to support a variety of Hewlett-Packard instruments, it may be more economical to work from one consolidated list rather than simply adding together stocking quantities from the individual instrument lists. Hewlett-Packard will prepare consolidated "Recommended Spares" lists for any number or combination of instruments. Contact your nearest Hewlett-Packard office for details.

Table 6-1. Reference Designations

REFERENCE DESIGNATIONS			
A assembly	E miscellaneous electrical part	P electrical connector (movable portion); plug	U integrated circuit; microcircuit
AT attenuator; isolator; termination	F fuse	Q transistor; SCR; triode thyristor	V electron tube
B fan; motor	FL filter	R resistor	VR voltage regulator; breakdown diode
BT battery	H hardware	RT thermistor	W cable; transmission path; wire
C capacitor	HY circulator	S switch	X socket
CP coupler	J electrical connector (stationary portion); jack	T transformer	Y crystal unit (piezo-electric or quartz)
CR diode; diode thyristor; varactor	K relay	TB terminal board	Z tuned cavity; tuned circuit
DC directional coupler	L coil; inductor	TC thermocouple	
DL delay line	M meter	TP test point	
DS annunciator; signaling device (audible or visual); lamp; LED	MP miscellaneous mechanical part		

Table 6-2. Abbreviations (1 of 2)

A ampere	COEF coefficient	EDP electronic data processing	INT internal
ac alternating current	COM common	ELECT electrolytic	kg kilogram
ACCESS accessory	COMP composition	ENCAP encapsulated	kHz kilohertz
ADJ adjustment	COMPL complete	EXT external	kΩ kilohm
A/D analog-to-digital	CONN connector	F farad	kV kilovolt
AF audio frequency	CP cadmium plate	FET field-effect transistor	lb pound
AFC automatic frequency control	CRT cathode-ray tube	F/F flip-flop	LC inductance-capacitance
AGC automatic gain control	CTL complementary transistor logic	FH flat head	LED light-emitting diode
AL aluminum	CW continuous wave	FIL H fillister head	LF low frequency
ALC automatic level control	cm centimeter	FM frequency modulation	LG long
AM amplitude modulation	D/A digital-to-analog	FP front panel	LH left hand
AMPL amplifier	dB decibel	FREQ frequency	LIM limit
APC automatic phase control	dBm decibel referred to 1 mW	FXD fixed	LIN linear taper (used in parts list)
ASSY assembly	dc direct current	g gram	lin linear
AUX auxiliary	deg degree (temperature interval or difference)	GE germanium	LK WASH lock washer
avg average	° degree (plane angle)	GHz gigahertz	LO low; local oscillator
AWG American wire gauge	°C degree Celsius (centigrade)	GL glass	LOG logarithmic taper (used in parts list)
BAL balance	°F degree Fahrenheit	GRD ground(ed)	log logarithm(ic)
BCD binary coded decimal	°K degree Kelvin	H henry	LPF low pass filter
BD board	DEPC deposited carbon	h hour	LV low voltage
BE CU beryllium copper	DET detector	HET heterodyne	m meter (distance)
BFO beat frequency oscillator	diam diameter	HEX hexagonal	mA milliamper
BH binder head	DIA diameter (used in parts list)	HD head	MAX maximum
BKDN breakdown	DIFF AMPL differential amplifier	HDW hardware	MΩ megohm
BP bandpass	div division	HF high frequency	MEG meg (10 ⁶) (used in parts list)
BPF bandpass filter	DPDT double-pole, double-throw	HG mercury	MET FLM metal film
BRS brass	DR drive	HI high	MET OX metallic oxide
BWO backward-wave oscillator	DSB double sideband	HP Hewlett-Packard	MF medium frequency; microfarad (used in parts list)
CAL calibrate	DTL diode transistor logic	HPF high pass filter	MFR manufacturer
ccw counter-clockwise	DVM digital voltmeter	HR hour (used in parts list)	mg milligram
CER ceramic	ECL emitter coupled logic	HV high voltage	MHz megahertz
CHAN channel	EMF electromotive force	Hz Hertz	mH millihenry
cm centimeter		IC integrated circuit	mho mho
CMO cabinet mount only		ID inside diameter	MIN minimum
COAX coaxial		IF intermediate frequency	min minute (time)
		IMPG impregnated minute (plane angle)
		in inch	MINAT miniature
		INCD incandescent	mm millimeter
		INCL include(s)	
		INP input	
		INS insulation	

NOTE

All abbreviations in the parts list will be in upper-case.

Table 6-2. Abbreviations (2 of 2)

MOD modulator	OD outside diameter	PWV peak working voltage	TD time delay
MOM momentary	OH oval head	RC resistance-capacitance	TERM terminal
MOS metal-oxide semiconductor	OP AMPL operational amplifier	RECT rectifier	TFT thin-film transistor
ms millisecond	OPT option	REF reference	TGL toggle
MTG mounting	OSC oscillator	REG regulated	THD thread
MTR meter (indicating device)	OX oxide	REPL replaceable	THRU through
mV millivolt	oz ounce	RF radio frequency	TI titanium
mVac millivolt, ac	Ω ohm	RFI radio frequency interference	TOL tolerance
mVdc millivolt, dc	P peak (used in parts list)	RH round head; right hand	TRIM trimmer
mVpk millivolt, peak	PAM pulse-amplitude modulation	RLC resistance-inductance-capacitance	TSTR transistor
mVp-p millivolt, peak-to-peak	PC printed circuit	RMO rack mount only	TTL transistor-transistor logic
mVrms millivolt, rms	PCM pulse-code modulation; pulse-count modulation	rms root-mean-square	TV television
mW milliwatt	PDM pulse-duration modulation	RND round	TVI television interference
MUX multiplex	pF picofarad	ROM read-only memory	TWT traveling wave tube
MY mylar	PH BRZ phosphor bronze	R&P rack and panel	U micro (10 ⁻⁶) (used in parts list)
μA microampere	PHL Phillips	RWV reverse working voltage	UF microfarad (used in parts list)
μF microfarad	PIN positive-intrinsic-negative	S scattering parameter	UHF ultrahigh frequency
μH microhenry	PIV peak inverse voltage	s second (time)	UNREG unregulated
μmho micromho	pk peak	” second (plane angle)	V volt
μs microsecond	PL phase lock	S-B slow-blow (fuse) (used in parts list)	VA voltampere
μV microvolt	PLO phase lock oscillator	SCR silicon controlled rectifier; screw	Vac volts, ac
μVac microvolt, ac	PM phase modulation	SE selenium	VAR variable
μVdc microvolt, dc	PNP positive-negative-positive	SECT sections	VCO voltage-controlled oscillator
μVpk microvolt, peak	P/O part of	SEMICON semiconductor	Vdc volts, dc
μVp-p microvolt, peak-to-peak	POLY polystyrene	SHF superhigh frequency	VDCW volts, dc, working (used in parts list)
μVrms microvolt, rms	PORC porcelain	SI silicon	V(F) volts, filtered
μW microwatt	POS positive; position(s) (used in parts list)	SIL silver	VFO variable-frequency oscillator
nA nanoampere	POSN position	SL slide	VHF very-high frequency
NC no connection	POT potentiometer	SNR signal-to-noise ratio	Vpk volts, peak
N/C normally closed	p-p peak-to-peak	SPDT single-pole, double-throw	Vp-p volts, peak-to-peak
NE neon	PP peak-to-peak (used in parts list)	SPG spring	Vrms volts, rms
NEG negative	PPM pulse-position modulation	SR split ring	VSWR voltage standing wave ratio
nF nanofarad	PREAMPL preamplifier	SPST single-pole, single-throw	VTO voltage-tuned oscillator
NI PL nickel plate	PRF pulse-repetition frequency	SSB single sideband	VTVM vacuum-tube voltmeter
N/O normally open	PRR pulse repetition rate	SST stainless steel	V(X) volts, switched
NOM nominal	ps picosecond	STL steel	W watt
NORM normal	PT point	SQ square	W/ with
NPN negative-positive-negative	PTM pulse-time modulation	SWR standing-wave ratio	WIV working inverse voltage
NPO negative-positive zero (zero temperature coefficient)	PWM pulse-width modulation	SYNC synchronize	WW wirewound
NRFR not recommended for field replacement		T timed (slow-blow fuse)	W/O without
NSR not separately replaceable		TA tantalum	YIG yttrium-iron-garnet
ns nanosecond		TC temperature compensating	Z _o characteristic impedance
nW nanowatt			
OBD order by description			

NOTE

All abbreviations in the parts list will be in upper-case.

MULTIPLIERS

Abbreviation	Prefix	Multiple
T	tera	10 ¹²
G	giga	10 ⁹
M	mega	10 ⁶
k	kilo	10 ³
da	deka	10
d	deci	10 ⁻¹
c	centi	10 ⁻²
m	milli	10 ⁻³
μ	micro	10 ⁻⁶
n	nano	10 ⁻⁹
p	pico	10 ⁻¹²
f	femto	10 ⁻¹⁵
a	atto	10 ⁻¹⁸

Table 6-3. Replaceable Parts

Reference Designation	HP Part Number	C D	Qty	Description	Mfr Code	Mfr Part Number
A1	08672-60175	0	2	PULSE DRIVER BOARD ASSEMBLY EXCEPT OPT. 009, 010	28480	08672-60175
A1C1	0160-3875	3	3	CAPACITOR-FXD 22PF +-5% 200VDC CER 0+-30	28480	0160-3875
A1C2	0160-3875	3	3	CAPACITOR-FXD 22PF +-5% 200VDC CER 0+-30	28480	0160-3875
A1C3	0160-2254	0	1	CAPACITOR-FXD 7.5PF +-25PF 500VDC CER	28480	0160-2254
A1C4	0160-3879	7	53	CAPACITOR-FXD .01UF +-20% 100VDC CER	28480	0160-3879
A1C5	0150-0059	0	1	CAPACITOR-FXD 3.3PF +-25PF 500VDC CER	28480	0150-0059
A1C6	0160-3879	7		CAPACITOR-FXD .01UF +-20% 100VDC CER	28480	0160-3879
A1C7	0140-0191	0	1	CAPACITOR-FXD 56PF +-5% 300VDC MICA	72136	DM15E56J0300V1CR
A1C8	0160-3879	7		CAPACITOR-FXD .01UF +-20% 100VDC CER	28480	0160-3879
A1C9	0160-3879	7		CAPACITOR-FXD .01UF +-20% 100VDC CER	28480	0160-3879
A1C10	0160-3879	7		CAPACITOR-FXD .01UF +-20% 100VDC CER	28480	0160-3879
A1C11	0160-3875	3		CAPACITOR-FXD 22PF +-5% 200VDC CER 0+-30	28480	0160-3875
A1C12	0160-0576	9	1	CAPACITOR-FXD 220PF +-20% 100VDC CER	20932	5024EM100RD221K
A1C13	0160-3879	7		CAPACITOR-FXD .01UF +-20% 100VDC CER	28480	0160-3879
A1C14	0160-3879	7		CAPACITOR-FXD .01UF +-20% 100VDC CER	28480	0160-3879
A1C15	0160-2220	0	1	CAPACITOR-FXD 1200PF +-5% 300VDC MICA	28480	0160-2220
A1C16	0160-3879	7		CAPACITOR-FXD .01UF +-20% 100VDC CER	28480	0160-3879
A1C17	0160-3879	7		CAPACITOR-FXD .01UF +-20% 100VDC CER	28480	0160-3879
A1C18	0160-3879	7		CAPACITOR-FXD .01UF +-20% 100VDC CER	28480	0160-3879
A1C19	0160-3879	7		CAPACITOR-FXD .01UF +-20% 100VDC CER	28480	0160-3879
A1C20	0160-3879	7		CAPACITOR-FXD .01UF +-20% 100VDC CER	28480	0160-3879
A1C21	0160-0571	0	1	CAPACITOR-FXD 470PF +-20% 100VDC CER	28480	0160-0571
A1C22	0160-0174	9	2	CAPACITOR-FXD .47UF +-80-20% 25VDC CER	28480	0160-0174
A1C23	0160-0174	9	2	CAPACITOR-FXD .47UF +-80-20% 25VDC CER	28480	0160-0174
A1C24	0160-3879	7		CAPACITOR-FXD .01UF +-20% 100VDC CER	28480	0160-3879
A1C25	0160-3879	7		CAPACITOR-FXD .01UF +-20% 100VDC CER	28480	0160-3879
A1C26	0160-3879	7		CAPACITOR-FXD .01UF +-20% 100VDC CER	28480	0160-3879
A1C27	0160-3879	7		CAPACITOR-FXD .01UF +-20% 100VDC CER	28480	0160-3879
A1C28	0160-3879	7		CAPACITOR-FXD .01UF +-20% 100VDC CER	28480	0160-3879
A1C29	0160-3879	7		CAPACITOR-FXD .01UF +-20% 100VDC CER	28480	0160-3879
A1C30	0160-3879	7		CAPACITOR-FXD .01UF +-20% 100VDC CER	28480	0160-3879
A1C31	0160-3879	7		CAPACITOR-FXD .01UF +-20% 100VDC CER	28480	0160-3879
A1C32	0100-0291	3	6	CAPACITOR-FXD 1UF+-10% 35VDC TA	56289	150D105X9035A2
A1C33	0100-0291	3	6	CAPACITOR-FXD 1UF+-10% 35VDC TA	56289	150D105X9035A2
A1C34	0100-0374	3	7	CAPACITOR-FXD 10UF+-10% 20VDC TA	56289	150D106X9020B2
A1C35	0100-0374	3	7	CAPACITOR-FXD 10UF+-10% 20VDC TA	56289	150D106X9020B2
A1C36	0160-0127	2	8	CAPACITOR-FXD 1UF +-20% 25VDC CER	28480	0160-0127
A1C37	0160-3878	6	1	CAPACITOR-FXD 1000PF +-20% 100VDC CER	28480	0160-3878
A1C38	0160-0127	2	8	CAPACITOR-FXD 1UF +-20% 25VDC CER	28480	0160-0127
A1C39	0160-3879	7		CAPACITOR-FXD .01UF +-20% 100VDC CER	28480	0160-3879
A1C40	0160-3879	7		CAPACITOR-FXD .01UF +-20% 100VDC CER	28480	0160-3879
A1CR1	1901-0535	9	2	DIODE-SM SIG SCHOTTKY	28480	1901-0535
A1CR2	1901-0535	9	2	DIODE-SM SIG SCHOTTKY	28480	1901-0535
A1CR3	1901-0040	1	3	DIODE-SWITCHING 30V 50MA 2NS DO-35	28480	1901-0040
A1CR4	1901-0040	1	3	DIODE-SWITCHING 30V 50MA 2NS DO-35	28480	1901-0040
A1CR5	1901-0364	2	1	DIODE-FW BRDG 200V 1A	28480	1901-0364
A1CR6	1901-0159	3	2	DIODE-PWR RECT 400V 750MA DO-41	28480	1901-0159
A1CR7	1901-0159	3	2	DIODE-PWR RECT 400V 750MA DO-41	28480	1901-0159
A1DS1	1990-0485	5	4	LED-LAMP LUM-INT=800UCD IF=30MA-MAX	28480	5082-4984
A1DS2	1990-0485	5	4	LED-LAMP LUM-INT=800UCD IF=30MA-MAX	28480	5082-4984
A1E1	9170-0029	3	8	CORE-SHIELDING BEAD	28480	9170-0029
A1E2	9170-0029	3	8	CORE-SHIELDING BEAD	28480	9170-0029
A1E3	9170-0029	3	8	CORE-SHIELDING BEAD	28480	9170-0029
A1E4	9170-0029	3	8	CORE-SHIELDING BEAD	28480	9170-0029
A1E5	9170-0029	3	8	CORE-SHIELDING BEAD	28480	9170-0029
A1E6	9170-0029	3	8	CORE-SHIELDING BEAD	28480	9170-0029
A1E7	9170-0029	3	8	CORE-SHIELDING BEAD	28480	9170-0029
A1E8	9170-0029	3	8	CORE-SHIELDING BEAD	28480	9170-0029
A1F1	2110-0063	1	2	FUSE .75A 250V NTD 1.25X.25 UL	28480	2110-0063
A1F2	2110-0063	1	2	FUSE .75A 250V NTD 1.25X.25 UL	28480	2110-0063
A1J1	1250-0835	1	7	CONNECTOR-RF SMC M PC 50-OHM	28480	1250-0835
A1J2	1250-0835	1	7	CONNECTOR-RF SMC M PC 50-OHM	28480	1250-0835
A1J3	1250-0835	1	7	CONNECTOR-RF SMC M PC 50-OHM	28480	1250-0835
A1J4	1251-7729	0	3	CONNECTOR-3 PIN	28480	1251-7729
A1J5	1250-0835	1	7	CONNECTOR-RF SMC M PC 50-OHM	28480	1250-0835
A1J6	1250-0835	1	7	CONNECTOR-RF SMC M PC 50-OHM	28480	1250-0835
A1J7	1251-7729	0	3	CONNECTOR-3 PIN	28480	1251-7729
A1K1	0490-1340	2	2	RELAY	28480	0490-1340
A1K2	0490-1340	2	2	RELAY	28480	0490-1340

See introduction to this section for ordering information
 *Indicates factory selected value

Table 6-3. Replaceable Parts

Reference Designation	HP Part Number	C D	Qty	Description	Mfr Code	Mfr Part Number
A1L1	9140-0210	1	3	INDUCTOR RF-CH-MLD 100UH 5% .166DX.385LG	28480	9140-0210
A1L2	9140-0210	1		INDUCTOR RF-CH-MLD 100UH 5% .166DX.385LG	28480	9140-0210
A1MP1	0340-0440	4	2	INSULATOR-IC NYLON WHITE	28480	0340-0440
A1MP2	0340-0440	4		INSULATOR-IC NYLON WHITE	28480	0340-0440
A1MP3	1205-0073	4	1	HEAT SINK TO-5/TO-39-CS	28480	1205-0073
A1MP4	1205-0012	1		HEAT SINK TO-18-CS	28480	1205-0012
A1MP5	1205-0012	1	HEAT SINK TO-18-CS	28480	1205-0012	
A1MP6	1205-0012	1	4	HEAT SINK TO-18-CS	28480	1205-0012
A1MP7	1205-0012	1		HEAT SINK TO-18-CS	28480	1205-0012
A1MP8	1205-0037	0	4	HEAT SINK TO-18-CS	28480	1205-0037
A1MP9	1205-0037	0		HEAT SINK TO-18-CS	28480	1205-0037
A1MP10	1205-0037	0	HEAT SINK TO-18-CS	28480	1205-0037	
A1MP11	1205-0037	0	2	HEAT SINK TO-18-CS	28480	1205-0037
A1MP12	11720-00008	8		CLIP	28480	11720-00008
A1MP13	11720-00008	8	CLIP	28480	11720-00008	
A1MP14	1400-0136	4	2	FUSEHOLDER-BLOCK 15A 250 V 1-FU	28480	1400-0136
A1MP15	2360-0201	9		SCREW-MACH 6-32 .5-IN-LG PAN-HD-POZI	00000	ORDER BY DESCRIPTION
A1MP16	3050-0227	3	2	WASHER-FL MTLC NO. 6 .149-IN-ID	28480	3050-0227
A1MP17	2190-0006	1		WASHER-LK HLCL NO. 6 .141-IN-ID	28480	2190-0006
A1MP18	2420-0002	6	3	NUT-HEX-DBL-CHAM 6-32-THD .169-IN-THK	28480	2420-0002
A1MP19	1400-0136	4		FUSEHOLDER-BLOCK 15A 250 V 1-FU	28480	1400-0136
A1MP20	2360-0201	9	SCREW-MACH 6-32 .5-IN-LG PAN-HD-POZI	00000	ORDER BY DESCRIPTION	
A1MP21	3050-0227	3	2	WASHER-FL MTLC NO. 6 .149-IN-ID	28480	3050-0227
A1MP22	2190-0006	1		WASHER-LK HLCL NO. 6 .141-IN-ID	28480	2190-0006
A1MP23	2420-0002	6	3	NUT-HEX-DBL-CHAM 6-32-THD .169-IN-THK	28480	2420-0002
A1MP24	2110-0269	0		FUSEHOLDER-CLIP TYPE.25D-FUSE	28480	2110-0269
A1MP25	2110-0269	0	FUSEHOLDER-CLIP TYPE.25D-FUSE	28480	2110-0269	
A1MP26	2110-0269	0	4	FUSEHOLDER-CLIP TYPE.25D-FUSE	28480	2110-0269
A1MP27	2110-0269	0		FUSEHOLDER-CLIP TYPE.25D-FUSE	28480	2110-0269
A1MP28						
A1MP31	08672-00103	8	4	INSULATOR, PLASTIC, FUSECLIP.	28480	08672-00103
A1Q1	1804-0012	9	3	THYRISTOR-SCR 2N3528 TO-B VRRM=200	3L505	2N3528
A1Q2	1804-0012	9		THYRISTOR-SCR 2N3528 TO-B VRRM=200	3L505	2N3528
A1Q3	1854-0401	7	4	TRANSISTOR NPN SI TO-72 PD=200MW	28480	1854-0401
A1Q4	1854-0401	7		TRANSISTOR NPN SI TO-72 PD=200MW	28480	1854-0401
A1Q5	1853-0430	0	4	TRANSISTOR PNP 2N4959 SI TO-72 PD=200MW	04713	2N4959
A1Q6	1853-0430	0		TRANSISTOR PNP 2N4959 SI TO-72 PD=200MW	04713	2N4959
A1Q7	1853-0430	0	4	TRANSISTOR PNP 2N4959 SI TO-72 PD=200MW	04713	2N4959
A1Q8	1853-0430	0		TRANSISTOR PNP 2N4959 SI TO-72 PD=200MW	04713	2N4959
A1Q9	1854-0401	7	4	TRANSISTOR NPN SI TO-72 PD=200MW	28480	1854-0401
A1Q10	1854-0401	7		TRANSISTOR NPN SI TO-72 PD=200MW	28480	1854-0401
A1R1	0698-3440	7	4	RESISTOR 196 1% .125W F TC=0+-100	24546	C4-1/8-T0-196R-F
A1R2	0698-3447	4		RESISTOR 422 1% .125W F TC=0+-100	24546	C4-1/8-T0-422R-F
A1R3	0698-3438	3	2	RESISTOR 147 1% .125W F TC=0+-100	24546	C4-1/8-T0-147R-F
A1R4	0698-3438	3		RESISTOR 147 1% .125W F TC=0+-100	24546	C4-1/8-T0-147R-F
A1R5	0757-0405	4	2	RESISTOR 162 1% .125W F TC=0+-100	24546	C4-1/8-T0-162R-F
A1R6	0698-3440	7		RESISTOR 196 1% .125W F TC=0+-100	24546	C4-1/8-T0-196R-F
A1R7	2100-1788	9	4	RESISTOR-TRMR 500 10% C TOP-ADJ 1-TRN	73138	B2PR500
A1R8	0698-7229	8		RESISTOR 511 1% .05W F TC=0+-100	24546	C3-1/8-T0-511R-F
A1R9	0698-7229	8	6	RESISTOR 511 1% .05W F TC=0+-100	24546	C3-1/8-T0-511R-F
A1R10	0698-3447	4		RESISTOR 422 1% .125W F TC=0+-100	24546	C4-1/8-T0-422R-F
A1R11	0698-7229	8	4	RESISTOR 511 1% .05W F TC=0+-100	24546	C3-1/8-T0-511R-F
A1R12	2100-1788	9		RESISTOR-TRMR 500 10% C TOP-ADJ 1-TRN	73138	B2PR500
A1R13	0698-7229	8	6	RESISTOR 511 1% .05W F TC=0+-100	24546	C3-1/8-T0-511R-F
A1R14	2100-1788	9		RESISTOR-TRMR 500 10% C TOP-ADJ 1-TRN	73138	B2PR500
A1R15	0698-7229	8	6	RESISTOR 511 1% .05W F TC=0+-100	24546	C3-1/8-T0-511R-F
A1R16	0698-7229	8		RESISTOR 511 1% .05W F TC=0+-100	24546	C3-1/8-T0-511R-F
A1R17	0757-0417	8	2	RESISTOR 562 1% .125W F TC=0+-100	24546	C4-1/8-T0-562R-F
A1R18*	0757-0417	8		RESISTOR 562 1% .125W F TC=0+-100	24546	C4-1/8-T0-562R-F
A1R19	0698-7206	1	2	RESISTOR 56.2 1% .05W F TC=0+-100	24546	C3-1/8-T0-56R2-F
A1R20	0698-7197	9		RESISTOR 23.7 1% .05W F TC=0+-100	24546	C3-1/8-T0-23R7-F
A1R21	0757-0405	4	2	RESISTOR 162 1% .125W F TC=0+-100	24546	C4-1/8-T0-162R-F
A1R22	0698-3442	9		RESISTOR 237 1% .125W F TC=0+-100	24546	C4-1/8-T0-237R-F
A1R23	0698-3440	7	2	RESISTOR 196 1% .125W F TC=0+-100	24546	C4-1/8-T0-196R-F
A1R24	0698-7206	1		RESISTOR 56.2 1% .05W F TC=0+-100	24546	C3-1/8-T0-56R2-F
A1R25	0698-3445	2	RESISTOR 348 1% .125W F TC=0+-100	24546	C4-1/8-T0-348R-F	
A1R26	0698-7197	9	4	RESISTOR 23.7 1% .05W F TC=0+-100	24546	C3-1/8-T0-23R7-F
A1R27	0698-3618	1		RESISTOR 82 5% 2W MO TC=0+-200	27167	FP42-2-T00-82R0-J
A1R28	0698-3440	7	1	RESISTOR 196 1% .125W F TC=0+-100	24546	C4-1/8-T0-196R-F
A1R29	0698-3620	5		RESISTOR 100 5% 2W MO TC=0+-200	28480	0698-3620
A1R30	2100-1788	9	RESISTOR-TRMR 500 10% C TOP-ADJ 1-TRN	73138	B2PR500	
A1R31	0698-3151	7	4	RESISTOR 2.87K 1% .125W F TC=0+-100	24546	C4-1/8-T0-2871-F
A1R32	0698-3150	6		RESISTOR 2.37K 1% .125W F TC=0+-100	24546	C4-1/8-T0-2371-F
A1R33	0698-0082	7	2	RESISTOR 464 1% .125W F TC=0+-100	24546	C4-1/8-T0-464R-F
A1R34	0757-0280	3		RESISTOR 1K 1% .125W F TC=0+-100	24546	C4-1/8-T0-1001-F
A1R35	0698-7212	9	1	RESISTOR 100 1% .05W F TC=0+-100	24546	C3-1/8-T0-100R-F

See introduction to this section for ordering information
 *Indicates factory selected value

Table 6-3. Replaceable Parts

Reference Designation	HP Part Number	C D	Qty	Description	Mfr Code	Mfr Part Number
A1R36	0698-7205	0	1	RESISTOR 51.1 1% .05W F TC=0+-100	24546	C3-1/8-T0-51R1-F
A1R37	0698-3446	3	1	RESISTOR 383 1% .125W F TC=0+-100	24546	C4-1/8-T0-383R-F
A1R38	0698-3445	2	1	RESISTOR 348 1% .125W F TC=0+-100	24546	C4-1/8-T0-348R-F
A1R39	0698-7188	8	2	RESISTOR 10 1% .05W F TC=0+-100	24546	C3-1/8-T0-10R-F
A1R40	0698-8670	9	1	RESISTOR 4.75 1% .125W F TC=0+-100	20480	6698-8670
A1R41	0698-3447	4	1	RESISTOR 422 1% .125W F TC=0+-100	24546	C4-1/8-T0-422R-F
A1R42	0698-7188	8	1	RESISTOR 10 1% .05W F TC=0+-100	24546	C3-1/8-T0-10R-F
A1R43	0757-0438	3	5	RESISTOR 5.11K 1% .125W F TC=0+-100	24546	C4-1/8-T0-5111-F
A1R44	0757-0438	3	1	RESISTOR 5.11K 1% .125W F TC=0+-100	24546	C4-1/8-T0-5111-F
A1R45	0757-0401	0	4	RESISTOR 100 1% .125W F TC=0+-100	24546	C4-1/8-T0-101-F
A1R46	0757-0401	0	1	RESISTOR 100 1% .125W F TC=0+-100	24546	C4-1/8-T0-101-F
A1R47	0757-0799	9	1	RESISTOR 121 1% .5W F TC=0+-100	20480	0757-0799
A1R48	0698-3611	4	1	RESISTOR 27 5% 2W MO TC=0+-200	27167	FP42-2-T00-27R0-J
A1R49	0698-3437	2	2	RESISTOR 133 1% .125W F TC=0+-100	24546	C4-1/8-T0-133R-F
A1R50	0698-3437	2	1	RESISTOR 133 1% .125W F TC=0+-100	24546	C4-1/8-T0-133R-F
A1TP1	1251-0600	0	29	CONNECTOR-SGL CONT PIN 1.14-MM-BSC-SZ SQ	20480	1251-0600
A1TP2	1251-0600	0	1	CONNECTOR-SGL CONT PIN 1.14-MM-BSC-SZ SQ	20480	1251-0600
A1TP3	1251-0600	0	1	CONNECTOR-SGL CONT PIN 1.14-MM-BSC-SZ SQ	20480	1251-0600
A1TP4	1251-0600	0	1	CONNECTOR-SGL CONT PIN 1.14-MM-BSC-SZ SQ	20480	1251-0600
A1TP5	1251-0600	0	1	CONNECTOR-SGL CONT PIN 1.14-MM-BSC-SZ SQ	20480	1251-0600
A1TP6	1251-0600	0	1	CONNECTOR-SGL CONT PIN 1.14-MM-BSC-SZ SQ	20480	1251-0600
A1TP7	1251-0600	0	1	CONNECTOR-SGL CONT PIN 1.14-MM-BSC-SZ SQ	20480	1251-0600
A1TP8	1251-0600	0	1	CONNECTOR-SGL CONT PIN 1.14-MM-BSC-SZ SQ	20480	1251-0600
A1TP9	1251-0600	0	1	CONNECTOR-SGL CONT PIN 1.14-MM-BSC-SZ SQ	20480	1251-0600
A1TP10	1251-0600	0	1	CONNECTOR-SGL CONT PIN 1.14-MM-BSC-SZ SQ	20480	1251-0600
A1TP11	1251-0600	0	1	CONNECTOR-SGL CONT PIN 1.14-MM-BSC-SZ SQ	20480	1251-0600
A1TP12	1251-0600	0	1	CONNECTOR-SGL CONT PIN 1.14-MM-BSC-SZ SQ	20480	1251-0600
A1TP13	1251-0600	0	1	CONNECTOR-SGL CONT PIN 1.14-MM-BSC-SZ SQ	20480	1251-0600
A1TP14	1251-0600	0	1	CONNECTOR-SGL CONT PIN 1.14-MM-BSC-SZ SQ	20480	1251-0600
A1TP15	1251-0600	0	1	CONNECTOR-SGL CONT PIN 1.14-MM-BSC-SZ SQ	20480	1251-0600
A1TP16	1251-0600	0	1	CONNECTOR-SGL CONT PIN 1.14-MM-BSC-SZ SQ	20480	1251-0600
A1TP17	1251-0600	0	1	CONNECTOR-SGL CONT PIN 1.14-MM-BSC-SZ SQ	20480	1251-0600
A1TP18	1251-0600	0	1	CONNECTOR-SGL CONT PIN 1.14-MM-BSC-SZ SQ	20480	1251-0600
A1U1	1820-1797	5	1	IC DRVR TTL 2-INP	27014	DH00350C
A1U2	1820-0917	8	1	IC FF ECL D-M/S DUAL	04713	MC10131P
A1U3	1820-0683	6	2	IC INV TTL S HEX 1-INP	01295	SN74S04N
A1U4	1820-0794	0	2	IC FF ECL D-M/S	04713	MC1670L
A1U5	1820-0794	0	1	IC FF ECL D-M/S	04713	MC1670L
A1U6	1820-1322	2	1	IC GATE TTL S NOR QUAD 2-INP	01295	SN74S02N
A1U7	1826-0179	7	1	IC V RGLTR T0-39	27014	LK320H-5.2
A1VR1	1902-0533	9	3	DIODE-ZNR 4.99V 2% DO-15 PD=1W TC=-.012%	20480	1902-0533
A1VR2	1902-0533	9	1	DIODE-ZNR 4.99V 2% DO-15 PD=1W TC=-.012%	20480	1902-0533
A1VR3	1902-0799	9	1	DIODE-ZNR 7.5V 5% PD=1W IR=10UA	20480	1902-0799
A1VR4	1902-3193	3	2	DIODE-ZNR 13.3V 5% DO-35 PD=.4W	20480	1902-3193
A1VR5	1902-3193	3	1	DIODE-ZNR 13.3V 5% DO-35 PD=.4W	20480	1902-3193
A1VR6	1902-0533	9	1	DIODE-ZNR 4.99V 2% DO-15 PD=1W TC=-.012%	20480	1902-0533
A1VR7	1902-0048	1	2	DIODE-ZNR 6.81V 5% DO-35 PD=.4W	20480	1902-0048
A1VR8	1902-0048	1	1	DIODE-ZNR 6.81V 5% DO-35 PD=.4W	20480	1902-0048
A1XU3	1200-0508	0	2	SOCKET-IC 14-CONT DIP-SLDR	20480	1200-0508
A2	08672-60184	1	1	DRIVER BOARD ASSEMBLY	20480	08672-60184
A2C1	0160-4084	8	8	CAPACITOR-FXD .1UF +-20% 50VDC CER	20480	0160-4084
A2C2	0180-0374	3	1	CAPACITOR-FXD 10UF+-10% 20VDC TA	56289	150D186X9020B2
A2C3	0160-4084	8	1	CAPACITOR-FXD .1UF +-20% 50VDC CER	20480	0160-4084
A2CR1	1901-0050	3	40	DIODE-SWITCHING 80V 200MA 2NS DO-35	20480	1901-0050
A2CR2	1901-0050	3	1	DIODE-SWITCHING 80V 200MA 2NS DO-35	20480	1901-0050
A2CR3	1901-0050	3	1	DIODE-SWITCHING 80V 200MA 2NS DO-35	20480	1901-0050
A2CR4	1901-0050	3	1	DIODE-SWITCHING 80V 200MA 2NS DO-35	20480	1901-0050
A2CR5	1901-0050	3	1	DIODE-SWITCHING 80V 200MA 2NS DO-35	20480	1901-0050
A2CR6	1901-0050	3	1	DIODE-SWITCHING 80V 200MA 2NS DO-35	20480	1901-0050
A2CR7	1901-0050	3	1	DIODE-SWITCHING 80V 200MA 2NS DO-35	20480	1901-0050
A2CR8	1901-0050	3	1	DIODE-SWITCHING 80V 200MA 2NS DO-35	20480	1901-0050
A2CR9	1901-0050	3	1	DIODE-SWITCHING 80V 200MA 2NS DO-35	20480	1901-0050
A2CR10	1901-0050	3	1	DIODE-SWITCHING 80V 200MA 2NS DO-35	20480	1901-0050
A2CR11	1901-0050	3	1	DIODE-SWITCHING 80V 200MA 2NS DO-35	20480	1901-0050
A2CR12	1901-0050	3	1	DIODE-SWITCHING 80V 200MA 2NS DO-35	20480	1901-0050
A2CR13	1901-0050	3	1	DIODE-SWITCHING 80V 200MA 2NS DO-35	20480	1901-0050
A2CR14	1901-0050	3	1	DIODE-SWITCHING 80V 200MA 2NS DO-35	20480	1901-0050
A2CR15	1901-0050	3	1	DIODE-SWITCHING 80V 200MA 2NS DO-35	20480	1901-0050
A2CR16	1901-0050	3	1	DIODE-SWITCHING 80V 200MA 2NS DO-35	20480	1901-0050
A2CR17	1901-0050	3	1	DIODE-SWITCHING 80V 200MA 2NS DO-35	20480	1901-0050
A2CR18	1901-0050	3	1	DIODE-SWITCHING 80V 200MA 2NS DO-35	20480	1901-0050
A2CR19	1901-0050	3	1	DIODE-SWITCHING 80V 200MA 2NS DO-35	20480	1901-0050
A2CR20	1901-0050	3	1	DIODE-SWITCHING 80V 200MA 2NS DO-35	20480	1901-0050

See introduction to this section for ordering information
 *Indicates factory selected value

Table 6-3. Replaceable Parts

Reference Designation	HP Part Number	C D	Qty	Description	Mfr Code	Mfr Part Number
A2CR21	1901-0050	3		DIODE-SWITCHING 80V 200MA 2NS DO-35	28480	1901-0050
A2CR22	1901-0050	3		DIODE-SWITCHING 80V 200MA 2NS DO-35	28480	1901-0050
A2CR23	1901-0050	3		DIODE-SWITCHING 80V 200MA 2NS DO-35	28480	1901-0050
A2CR24	1901-0050	3		DIODE-SWITCHING 80V 200MA 2NS DO-35	28480	1901-0050
A2CR25	1901-0050	3		DIODE-SWITCHING 80V 200MA 2NS DO-35	28480	1901-0050
A2CR26	1901-0050	3		DIODE-SWITCHING 80V 200MA 2NS DO-35	28480	1901-0050
A2CR27	1901-0050	3		DIODE-SWITCHING 80V 200MA 2NS DO-35	28480	1901-0050
A2CR28	1901-0050	3		DIODE-SWITCHING 80V 200MA 2NS DO-35	28480	1901-0050
A2CR29	1901-0050	3		DIODE-SWITCHING 80V 200MA 2NS DO-35	28480	1901-0050
A2CR30	1901-0050	3		DIODE-SWITCHING 80V 200MA 2NS DO-35	28480	1901-0050
A2CR31	1901-0050	3		DIODE-SWITCHING 80V 200MA 2NS DO-35	28480	1901-0050
A2CR32	1901-0050	3		DIODE-SWITCHING 80V 200MA 2NS DO-35	28480	1901-0050
A2CR33	1901-0050	3		DIODE-SWITCHING 80V 200MA 2NS DO-35	28480	1901-0050
A2CR34	1901-0050	3		DIODE-SWITCHING 80V 200MA 2NS DO-35	28480	1901-0050
A2CR35	1901-0050	3		DIODE-SWITCHING 80V 200MA 2NS DO-35	28480	1901-0050
A2CR36	1901-0050	3		DIODE-SWITCHING 80V 200MA 2NS DO-35	28480	1901-0050
A2CR37	1901-0050	3		DIODE-SWITCHING 80V 200MA 2NS DO-35	28480	1901-0050
A2CR38	1901-0050	3		DIODE-SWITCHING 80V 200MA 2NS DO-35	28480	1901-0050
A2CR39	1901-0050	3		DIODE-SWITCHING 80V 200MA 2NS DO-35	28480	1901-0050
A2CR40	1901-0050	3		DIODE-SWITCHING 80V 200MA 2NS DO-35	28480	1901-0050
A2CR41	1901-0050	3		DIODE-SWITCHING 80V 200MA 2NS DO-35	28480	1901-0050
A2CR42	1901-0050	3		DIODE-SWITCHING 80V 200MA 2NS DO-35	28480	1901-0050
A2CR43	1901-0050	3		DIODE-SWITCHING 80V 200MA 2NS DO-35	28480	1901-0050
A2K1	0490-1190	0	2	RELAY 2C 5VDC-COIL .5A 125VAC	28480	0490-1190
A2K2	0490-1190	0	0	RELAY 2C 5VDC-COIL .5A 125VAC	28480	0490-1190
A2MP1	5040-6847	6	1	BOARD-EXTRACTOR (RED)	28480	5040-6847
	5000-9043	6	5	PIN-P.C. BOARD EXTRACTOR	28480	5000-9043
A2MP2	11713-20009	2	1	DRIVER SUPPORT	28480	11713-20009
	2200-0107	6	8	SCREW-MACH 4-40 .375-IN-LG PAN-HD-POZI	00000	ORDER BY DESCRIPTION
	3050-0105	6	12	WASHER-FL MTLG NO. 4 .125-IN-ID	28480	3050-0105
A2Q1	1854-0810	2	18	TRANSISTOR NPN SI PD=625MW FT=200MHZ	28480	1854-0810
	2200-0149	6	4	SCREW-MACH 4-40 .625-IN-LG PAN-HD-POZI	00000	ORDER BY DESCRIPTION
	2260-0009	3	12	NUT-HEX-W/LKWR 4-40-THD .094-IN-THK	00000	ORDER BY DESCRIPTION
A2Q2	1854-0810	2	18	TRANSISTOR NPN SI PD=625MW FT=200MHZ	28480	1854-0810
	2200-0149	6	6	SCREW-MACH 4-40 .625-IN-LG PAN-HD-POZI	00000	ORDER BY DESCRIPTION
	2260-0009	3	3	NUT-HEX-W/LKWR 4-40-THD .094-IN-THK	00000	ORDER BY DESCRIPTION
A2Q3	1854-0633	7	16	TRANSISTOR NPN SI DARL PD=40W	04713	MJE800
A2Q4	1854-0633	7		TRANSISTOR NPN SI DARL PD=40W	04713	MJE800
A2Q5	1854-0633	7		TRANSISTOR NPN SI DARL PD=40W	04713	MJE800
A2Q6	1854-0633	7		TRANSISTOR NPN SI DARL PD=40W	04713	MJE800
A2Q7	1854-0633	7		TRANSISTOR NPN SI DARL PD=40W	04713	MJE800
A2Q8	1854-0633	7		TRANSISTOR NPN SI DARL PD=40W	04713	MJE800
A2Q9	1854-0633	7		TRANSISTOR NPN SI DARL PD=40W	04713	MJE800
A2Q10	1854-0633	7		TRANSISTOR NPN SI DARL PD=40W	04713	MJE800
A2Q11	1854-0633	7		TRANSISTOR NPN SI DARL PD=40W	04713	MJE800
A2Q12	1854-0633	7		TRANSISTOR NPN SI DARL PD=40W	04713	MJE800
A2Q13	1854-0633	7		TRANSISTOR NPN SI DARL PD=40W	04713	MJE800
A2Q14	1854-0633	7		TRANSISTOR NPN SI DARL PD=40W	04713	MJE800
A2Q15	1854-0633	7		TRANSISTOR NPN SI DARL PD=40W	04713	MJE800
A2Q16	1854-0633	7		TRANSISTOR NPN SI DARL PD=40W	04713	MJE800
A2Q17	1854-0633	7		TRANSISTOR NPN SI DARL PD=40W	04713	MJE800
A2Q18	1854-0633	7		TRANSISTOR NPN SI DARL PD=40W	04713	MJE800
A2Q19	1854-0810	2	18	TRANSISTOR NPN SI PD=625MW FT=200MHZ	28480	1854-0810
	2200-0149	6	6	SCREW-MACH 4-40 .625-IN-LG PAN-HD-POZI	00000	ORDER BY DESCRIPTION
	2260-0009	3	3	NUT-HEX-W/LKWR 4-40-THD .094-IN-THK	00000	ORDER BY DESCRIPTION
A2Q20	1854-0810	2	18	TRANSISTOR NPN SI PD=625MW FT=200MHZ	28480	1854-0810
	2200-0149	6	6	SCREW-MACH 4-40 .625-IN-LG PAN-HD-POZI	00000	ORDER BY DESCRIPTION
	2260-0009	3	3	NUT-HEX-W/LKWR 4-40-THD .094-IN-THK	00000	ORDER BY DESCRIPTION
A2R1	0698-0084	2	2	RESISTOR 13.3K 1% .125W F TC=0+-100	19701	MF401/8-T0-1332-F
A2R2	0698-0084	9	16	RESISTOR 2.15K 1% .125W F TC=0+-100	24546	C4-1/8-T0-2151-F
A2R3	0698-0084	9		RESISTOR 2.15K 1% .125W F TC=0+-100	24546	C4-1/8-T0-2151-F
A2R4	0698-0084	9		RESISTOR 2.15K 1% .125W F TC=0+-100	24546	C4-1/8-T0-2151-F
A2R5	0698-0084	9		RESISTOR 2.15K 1% .125W F TC=0+-100	24546	C4-1/8-T0-2151-F
A2R6	0757-0289	2		RESISTOR 13.3K 1% .125W F TC=0+-100	19701	MF401/8-T0-1332-F
A2R7	0698-0084	9		RESISTOR 2.15K 1% .125W F TC=0+-100	24546	C4-1/8-T0-2151-F
A2R8	0698-0084	9		RESISTOR 2.15K 1% .125W F TC=0+-100	24546	C4-1/8-T0-2151-F
A2R9	0698-0084	9		RESISTOR 2.15K 1% .125W F TC=0+-100	24546	C4-1/8-T0-2151-F
A2R10	0698-0084	9		RESISTOR 2.15K 1% .125W F TC=0+-100	24546	C4-1/8-T0-2151-F
A2R11	0698-0084	9		RESISTOR 2.15K 1% .125W F TC=0+-100	24546	C4-1/8-T0-2151-F
A2R12	0698-0084	9		RESISTOR 2.15K 1% .125W F TC=0+-100	24546	C4-1/8-T0-2151-F
A2R13	0698-0084	9		RESISTOR 2.15K 1% .125W F TC=0+-100	24546	C4-1/8-T0-2151-F
A2R14	0698-0084	9		RESISTOR 2.15K 1% .125W F TC=0+-100	24546	C4-1/8-T0-2151-F
A2R15	0698-0084	9		RESISTOR 2.15K 1% .125W F TC=0+-100	24546	C4-1/8-T0-2151-F
A2R16	0698-0084	9		RESISTOR 2.15K 1% .125W F TC=0+-100	24546	C4-1/8-T0-2151-F
A2R17	0698-0084	9		RESISTOR 2.15K 1% .125W F TC=0+-100	24546	C4-1/8-T0-2151-F
A2R18	0698-0084	9		RESISTOR 2.15K 1% .125W F TC=0+-100	24546	C4-1/8-T0-2151-F

See introduction to this section for ordering information
 *Indicates factory selected value

Table 6-3. Replaceable Parts

Reference Designation	HP Part Number	C D	Qty	Description	Mfr Code	Mfr Part Number
A2U1	1820-1973	9	2	IC SWITCH ANLG 8-DIP-P PKG	01295	TL6041P
A2U2	1820-1973	9		IC SWITCH ANLG 8-DIP-P PKG	01295	TL6041P
A3	11713-60003	0	2	LATCH BOARD ASSEMBLY	28480	11713-60003
A3C1	0160-4084	8		CAPACITOR-FXD .1UF +-20% 50VDC CER	28480	0160-4084
A3C2	0160-4084	8		CAPACITOR-FXD .1UF +-20% 50VDC CER	28480	0160-4084
A3C3	0160-4084	8		CAPACITOR-FXD .1UF +-20% 50VDC CER	28480	0160-4084
A3C4	0180-0229	7	2	CAPACITOR-FXD 33UF+-10% 10VDC TA	56289	150D336X9010B2
A3C5	0160-4084	8		CAPACITOR-FXD .1UF +-20% 50VDC CER	28480	0160-4084
A3C6	0180-0229	7		CAPACITOR-FXD 33UF+-10% 10VDC TA	56289	150D336X9010B2
A3C7	0180-0374	3		CAPACITOR-FXD 10UF+-10% 20VDC TA	56289	150D106X9020B2
A3CR1	1901-0040	1		DIODE-SWITCHING 30V 50MA 2NS DO-35	28480	1901-0040
A3MP1	5040-6852	3	1	BOARD EXTRACTOR (ORANGE)	28480	5040-6852
	5000-9043	6		PIN-P.C. BOARD EXTRACTOR	28480	5000-9043
A3Q1	1854-0810	2		TRANSISTOR NPN 51 PD=625MW FT=200MHZ	28480	1854-0810
A3R1	0757-0444	1	3	RESISTOR 12.1K 1% .125W F TC=0+-100	24546	C4-1/B-T0-1212-F
A3R2	0757-0444	1		RESISTOR 12.1K 1% .125W F TC=0+-100	24546	C4-1/B-T0-1212-F
A3R3	0757-0280	3		RESISTOR 1K 1% .125W F TC=0+-100	24546	C4-1/B-T0-1001-F
A3U1	1820-1212	9	5	IC FF TTL LS J-K NEG-EDGE-TRIG	01295	SN74LS112AN
A3U2	1820-1212	9		IC FF TTL LS J-K NEG-EDGE-TRIG	01295	SN74LS112AN
A3U3	1820-1212	9		IC FF TTL LS J-K NEG-EDGE-TRIG	01295	SN74LS112AN
A3U4	1820-1212	9		IC FF TTL LS J-K NEG-EDGE-TRIG	01295	SN74LS112AN
A3U5	1820-1212	9		IC FF TTL LS J-K NEG-EDGE-TRIG	01295	SN74LS112AN
A3U6	1820-0683	6		IC INV TTL S HEX 1-INP	01295	SN74S04N
A3U7	1820-0681	4	1	IC GATE TTL S NAND QUAD 2-INP	01295	SN74S00N
A3VR1	1902-3070	5	1	DIODE-ZNR 4.22V 5% DO-35 PD=.4W	28480	1902-3070
A4	11713-60004	1	2	LOGIC BOARD ASSEMBLY	28480	11713-60004
A4C1	0160-2055	9	14	CAPACITOR-FXD .01UF +80-20% 100VDC CER	28480	0160-2055
A4C2	0160-2055	9		CAPACITOR-FXD .01UF +80-20% 100VDC CER	28480	0160-2055
A4C3	0160-2055	9		CAPACITOR-FXD .01UF +80-20% 100VDC CER	28480	0160-2055
A4C4	0160-2055	9		CAPACITOR-FXD .01UF +80-20% 100VDC CER	28480	0160-2055
A4C5	0160-2055	9		CAPACITOR-FXD .01UF +80-20% 100VDC CER	28480	0160-2055
A4C6	0160-2055	9		CAPACITOR-FXD .01UF +80-20% 100VDC CER	28480	0160-2055
A4C7	0160-2055	9		CAPACITOR-FXD .01UF +80-20% 100VDC CER	28480	0160-2055
A4C8	0180-0374	3		CAPACITOR-FXD 10UF+-10% 20VDC TA	56289	150D106X9020B2
A4MP1	5040-6848	7	1	BOARD EXTRACTOR (YELLOW)	28480	5040-6848
	5000-9043	6		PIN-P.C. BOARD EXTRACTOR	28480	5000-9043
A4R1	0757-0280	3		RESISTOR 1K 1% .125W F TC=0+-100	24546	C4-1/B-T0-1001-F
A4U1	1820-1428	9	3	IC MUXR/DATA-SEL TTL LS 2-TO-1-LINE QUAD	01295	SN74LS159N
A4U2	1820-1216	3	2	IC DCDR TTL LS 3-TO-8-LINE 3-INP	01295	SN74LS138N
A4U3	1820-1428	9		IC MUXR/DATA-SEL TTL LS 2-TO-1-LINE QUAD	01295	SN74LS159N
A4U4	1820-1202	7	1	IC GATE TTL LS NAND TPL 3-INP	01295	SN74LS10N
A4U5	1820-1204	9	1	IC GATE TTL LS NAND DUAL 4-INP	01295	SN74LS20N
A4U6	1820-1112	8	5	IC FF TTL LS D-TYPE POS-EDGE-TRIG	01295	SN74LS74AN
A4U7	1820-1428	9		IC MUXR/DATA-SEL TTL LS 2-TO-1-LINE QUAD	01295	SN74LS159N
A4U8	1820-1216	3		IC DCDR TTL LS 3-TO-8-LINE 3-INP	01295	SN74LS138N
A4U9	1820-1112	8		IC FF TTL LS D-TYPE POS-EDGE-TRIG	01295	SN74LS74AN
A4U10	1820-1199	1	2	IC INV TTL LS HEX 1-INP	01295	SN74LS04N
A4U11	1820-1197	9	1	IC GATE TTL LS NAND QUAD 2-INP	01295	SN74LS00N
A5	11713-60005	2	2	HP-1B BOARD ASSEMBLY	28480	11713-60005
A5C1	0160-2055	9		CAPACITOR-FXD .01UF +80-20% 100VDC CER	28480	0160-2055
A5C2	0160-2055	9		CAPACITOR-FXD .01UF +80-20% 100VDC CER	28480	0160-2055
A5C3	0160-2055	9		CAPACITOR-FXD .01UF +80-20% 100VDC CER	28480	0160-2055
A5C4	0160-2055	9		CAPACITOR-FXD .01UF +80-20% 100VDC CER	28480	0160-2055
A5C5	0160-5030	6	2	CAPACITOR-FXD 2200PF +-5% 300VAC(RMS)	28480	0160-5030
A5C6	0160-2055	9		CAPACITOR-FXD .01UF +80-20% 100VDC CER	28480	0160-2055
A5C7	0160-3533	0	1	CAPACITOR-FXD 470PF +-5% 300VDC MICA	28480	0160-3533
A5C8	0160-5030	6		CAPACITOR-FXD 2200PF +-5% 300VAC(RMS)	28480	0160-5030
A5C9	0180-0374	3		CAPACITOR-FXD 10UF+-10% 20VDC TA	56289	150D106X9020B2
A5C10	0140-0192	9	2	CAPACITOR-FXD 68PF +-5% 300VDC MICA	72136	DM15E680J0300WV1CR
A5C11	0140-0192	9		CAPACITOR-FXD 68PF +-5% 300VDC MICA	72136	DM15E680J0300WV1CR
A5MP1	5040-6851	2	1	BOARD EXTRACTOR (GREEN)	28480	5040-6851
	5000-9043	6		PIN-P.C. BOARD EXTRACTOR	28480	5000-9043

See introduction to this section for ordering information
 *Indicates factory selected value

Table 6-3. Replaceable Parts

Reference Designation	HP Part Number	C D	Qty	Description	Mfr Code	Mfr Part Number
ASR1	0698-3444	1	10	RESISTOR 316 1% .125W F TC=0+-100	24546	C4-1/8-T0-316R-F
ASR2	0698-3444	1		RESISTOR 316 1% .125W F TC=0+-100	24546	C4-1/8-T0-316R-F
ASR3	0698-3444	1		RESISTOR 316 1% .125W F TC=0+-100	24546	C4-1/8-T0-316R-F
ASR4	0757-0199	3	4	RESISTOR 21.5K 1% .125W F TC=0+-100	24546	C4-1/8-T0-2152-F
ASR5	0757-0199	3		RESISTOR 21.5K 1% .125W F TC=0+-100	24546	C4-1/8-T0-2152-F
ASR6	0757-0199	3		RESISTOR 21.5K 1% .125W F TC=0+-100	24546	C4-1/8-T0-2152-F
ASR7	0757-0438	3		RESISTOR 5.11K 1% .125W F TC=0+-100	24546	C4-1/8-T0-5111-F
ASR8	0757-0438	3		RESISTOR 5.11K 1% .125W F TC=0+-100	24546	C4-1/8-T0-5111-F
ASU1	1820-0621	2	1	IC BFR TTL NAND QUAD 2-INP	01295	SN7438N
ASU2	1820-1112	8		IC FF TTL LS D-TYPE POS-EDGE-TRIG	01295	SN74LS74AN
ASU3	1820-1287	2	1	IC GATE TTL LS NAND 8-INP	01295	SN74LS30N
ASU4	1820-0215	0	1	IC DCDR TTL BCD-T0-DEC 4-T0-10-LINE	28480	1326-0215
ASU5	1820-0964	4	1	IC COMPTR TTL L MAGTD 5-BIT	07263	93L24PC
ASU6	1820-1416	5	2	IC SCHMITT-TRIG TTL LS INV HEX 1-INP	01295	SN74LS14N
ASU7	1820-1416	5		IC SCHMITT-TRIG TTL LS INV HEX 1-INP	01295	SN74LS14N
ASU8	11713-80002	1	1	ROM-PROGRAMMED	28480	11713-80002
ASU9	1820-1199	1		IC INV TTL LS HEX 1-INP	01295	SN74LS04N
A6	08672-60168	1	2	MOTHERBOARD ASSEMBLY	28480	08672-60168
A6C1	0180-0291	3		CAPACITOR-FXD 1UF+-10% 35VDC TA	56289	150D105X9035A2
A6C2	0180-2141	6	1	CAPACITOR-FXD 3.3UF+-10% 50VDC TA	56289	150D335X9050B2
A6C3	0180-0197	8	4	CAPACITOR-FXD 2.2UF+-10% 28VDC TA	56289	150D225X9028A2
A6C4	0160-3879	7		CAPACITOR-FXD .01UF +-20% 100VDC CER	28480	0160-3879
A6C5	0160-3879	7		CAPACITOR-FXD .01UF +-20% 100VDC CER	28480	0160-3879
A6C6	0160-3879	7		CAPACITOR-FXD .01UF +-20% 100VDC CER	28480	0160-3879
A6CR1	1901-0328	8	6	DIODE-PWR RECT 400V 1A 6US	03508	A14D
A6CR2	1901-0200	5	2	DIODE-PWR RECT 100V 1.5A	28480	1901-0200
A6CR3	1901-0328	8		DIODE-PWR RECT 400V 1A 6US	03508	A14D
A6CR4	1901-0328	8		DIODE-PWR RECT 400V 1A 6US	03508	A14D
A6CR5	1901-0200	5		DIODE-PWR RECT 100V 1.5A	28480	1901-0200
A6CR6	1901-0328	8		DIODE-PWR RECT 400V 1A 6US	03508	A14D
A6J1	1200-0507	9	2	SOCKET-IC 16-CONT DIP-SLDR	28480	1200-0507
A6J2	1251-5316	5	4	CONNECTOR 34-PIN POST SERIES	28480	1251-5316
A6J3	1251-5316	5		CONNECTOR 34-PIN POST SERIES	28480	1251-5316
A6J4	1251-5635	1	1	CONNECTOR 12-PIN M POST TYPE	28480	1251-5635
A6Q1	1884-0812	9		THYRISTOR-SCR 2N3528 T0-8 VRRM=200	3L585	2N3528
A6R1	1810-0136	3	2	NETWORK-RES 10-SIP MULTI-VALUE	28480	1810-0136
A6R2	1810-0136	3		NETWORK-RES 10-SIP MULTI-VALUE	28480	1810-0136
A6R3	1810-0041	7	1	NETWORK-RES 9-SIP2.7K OHM X B	28480	1810-0041
A6R4	0698-0982	9		RESISTOR 464 1% .125W F TC=0+-100	24546	C4-1/8-T0-4640-F
A6R5	0757-0438	3		RESISTOR 5.11K 1% .125W F TC=0+-100	24546	C4-1/8-T0-5111-F
A6TP1	1251-0600	0		CONNECTOR-SGL CONT PIN 1.14-MM-BSC-SZ SQ	28480	1251-0600
A6TP2	1251-0600	0		CONNECTOR-SGL CONT PIN 1.14-MM-BSC-SZ SQ	28480	1251-0600
A6VR1	1902-3326	4	1	DIODE-ZNR 43.2V 5% D0-35 PD=.4W TC=+.08%	28480	1902-3326
A6XA2	1251-1365	6	4	CONNECTOR-PC EDGE 22-CONT/ROW 2-ROWS	28480	1251-1365
A6XA3	1251-1365	6		CONNECTOR-PC EDGE 22-CONT/ROW 2-ROWS	28480	1251-1365
A6XA4	1251-1365	6		CONNECTOR-PC EDGE 22-CONT/ROW 2-ROWS	28480	1251-1365
A6XA5	1251-1365	6		CONNECTOR-PC EDGE 22-CONT/ROW 2-ROWS	28480	1251-1365
A7	08672-60164	7	2	IF PANEL BOARD ASSEMBLY	28480	08672-60164
A7J1	1251-5399	4	1	CONNECTOR 12-PIN M CIRCULAR THOROM	28480	1251-5399
A7J2	1251-4736	1	2	CONNECTOR 26-PIN M RECTANGULAR	28480	1251-4736
A7J3	1251-5316	5		CONNECTOR 34-PIN POST SERIES	28480	1251-5316
A7S1	3101-1973	7	1	SWITCH-SL 7-1A DIP-SLIDE-ASSY .1A 50VDC	28480	3101-1973
A8	08672-60169	2	2	HP-IB BOARD ASSEMBLY	28480	08672-60169
A8J1	1251-3283	1	1	CONNECTOR 24-PIN F MICRORIBBON	28480	1251-3283
A8J2	1200-0507	9		SOCKET-IC 16-CONT DIP-SLDR	28480	1200-0507
ASMP1	0380-0643	3	2	STANDOFF-HEX .255-IN-LG 6-32THD	00000	ORDER BY DESCRIPTION
ASMP2	0380-0643	3		STANDOFF-HEX .255-IN-LG 6-32THD	00000	ORDER BY DESCRIPTION
ASMP3	1530-1098	4	2	CLEVIS 0.070-IN W SLT; 0.454-IN PIN CTR	00000	ORDER BY DESCRIPTION
ASMP4	1530-1098	4		CLEVIS 0.070-IN W SLT; 0.454-IN PIN CTR	00000	ORDER BY DESCRIPTION
ASMP5	2260-0009	3	3	NUT-HEX-W/LKWR 4-40-THD .094-IN-THK	00000	ORDER BY DESCRIPTION
ASMP6	2260-0009	3		NUT-HEX-W/LKWR 4-40-THD .094-IN-THK	00000	ORDER BY DESCRIPTION
ASMP7	2200-0109	8	2	SCREW-MACH 4-40 .438-IN-LG PAN-HD-POZI	00000	ORDER BY DESCRIPTION
ASMP8	2200-0109	8		SCREW-MACH 4-40 .438-IN-LG PAN-HD-POZI	00000	ORDER BY DESCRIPTION

See introduction to this section for ordering information
 *Indicates factory selected value

Table 6-3. Replaceable Parts

Reference Designation	HP Part Number	C D	Qty	Description	Mfr Code	Mfr Part Number
A9	08672-60166	9	2	POWER SUPPLY BOARD ASSEMBLY	20480	08672-60166
A9C1	0160-3094	8	2	CAPACITOR-FXD .1UF +-10% 100VDC CER	20480	0160-3094
A9C2	0160-3094	8	2	CAPACITOR-FXD .1UF +-10% 100VDC CER	20480	0160-3094
A9C3	0180-0116	1	1	CAPACITOR-FXD 6.0UF+-10% 35VDC TA	56289	150D605X9035B2
A9C4	0180-0374	3	3	CAPACITOR-FXD 10UF+-10% 28VDC TA	56289	150D104X9020B2
A9C5	0160-0576	5	3	CAPACITOR-FXD .1UF +-20% 50VDC CER	20480	0160-0576
A9C6	0160-0576	5		CAPACITOR-FXD .1UF +-20% 50VDC CER	20480	0160-0576
A9CR1	1901-0020	5	2	DIODE-PWR RECT 400V 750MA DO-29	20480	1901-0020
A9CR2	1901-0020	5	2	DIODE-PWR RECT 400V 750MA DO-29	20480	1901-0020
A9CR3	1901-0320	8		DIODE-PWR RECT 400V 1A 6US	03508	A140
A9CR4	1901-0320	8		DIODE-PWR RECT 400V 1A 6US	03508	A140
A9CR5	1990-0405	5		LED-LAMP LUM-INT=800UCD IF=30MA-MAX	20480	5082-4984
A9CR6	1990-0405	5		LED-LAMP LUM-INT=800UCD IF=30MA-MAX	20480	5082-4984
A9F1	2110-0516	0	1	FUSE 1A 125V NTD .348X.25	75915	273001
A9F2	2110-0515	9	1	FUSE .5A 125V NTD .348X.25	75915	273.500
A9J1	1251-4736	1		CONNECTOR 26-PIN M RECTANGULAR	20480	1251-4736
A9J2	1251-7720	7	1	CONNECTOR-- 12 PIN	20480	1251-7720
A9J3	1251-7730	1	4	CONNECTOR-- 11 PIN	20480	1251-7730
A9J4	1251-7730	1	1	CONNECTOR-- 11 PIN	20480	1251-7730
A9J5	1200-0500	0		SOCKET-IC 14-CONT DIP-SLDR	20480	1200-0500
A9MP1	1251-1998	1	4	CONNECTOR-SGL CONT SKT .025-IN-BSC-SZ	20480	1251-1998
A9MP2	1251-1998	1		CONNECTOR-SGL CONT SKT .025-IN-BSC-SZ	20480	1251-1998
A9MP3	1251-1998	1		CONNECTOR-SGL CONT SKT .025-IN-BSC-SZ	20480	1251-1998
A9MP4	1251-1998	1		CONNECTOR-SGL CONT SKT .025-IN-BSC-SZ	20480	1251-1998
A9Q1	1804-0010	5	2	THYRISTOR-SCR 2N4106 VRRM=200	04713	2N4106
A9Q2	1804-0010	5	2	THYRISTOR-SCR 2N4106 VRRM=200	04713	2N4106
A9R1	0757-0833	2	1	RESISTOR 5.11K 1% .5W F TC=0+-100	20480	0757-0833
A9R2	0698-3411	2	1	RESISTOR 3.40K 1% .5W F TC=0+-100	20480	0698-3411
A9R3	0698-3132	4	4	RESISTOR 261 1% .125W F TC=0+-100	24546	C4-1/8-T0-2610-F
A9R4	2100-3056	8	1	RESISTOR-TRMR 5K 10% C SIDE-ADJ 17-TRN	02111	43P502
A9R5	0698-3441	8	1	RESISTOR 215 1% .125W F TC=0+-100	24546	C4-1/8-T0-215R-F
A9R6	2100-3109	2	1	RESISTOR-TRMR 2K 10% C SIDE-ADJ 17-TRN	02111	43P202
A9R7	0698-3444	1		RESISTOR 316 1% .125W F TC=0+-100	24546	C4-1/8-T0-316R-F
A9R8	0698-3444	1		RESISTOR 316 1% .125W F TC=0+-100	24546	C4-1/8-T0-316R-F
A9R9	0757-0346	2	24	RESISTOR 10 1% .125W F TC=0+-100	24546	C4-1/8-T0-10R0-F
A9R10	0757-0346	2	24	RESISTOR 10 1% .125W F TC=0+-100	24546	C4-1/8-T0-10R0-F
A9R11	0698-0089	4	1	RESISTOR 1.70K 1% .5W F TC=0+-100	20480	0698-0089
A9R12	0757-0421	4	1	RESISTOR 825 1% .125W F TC=0+-100	24546	C4-1/8-T0-825R-F
A9R13	0698-3151	7		RESISTOR 2.07K 1% .125W F TC=0+-100	24546	C4-1/8-T0-2071-F
A9R14	0757-0200	3		RESISTOR 1K 1% .125W F TC=0+-100	24546	C4-1/8-T0-1001-F
A9TP1	0360-0535	0	2	TERMINAL TEST POINT PCB	00000	ORDER BY DESCRIPTION
A9TP2	0360-0535	0	2	TERMINAL TEST POINT PCB	00000	ORDER BY DESCRIPTION
A9VR1	1902-0967	3	1	DIODE-ZNR 24V 5% DO-35 PD=.4W TC=+.094%	20480	1902-0967
A9VR2	1902-0961	7	1	DIODE-ZNR 13V 5% DO-35 PD=.4W TC=+.082%	20480	1902-0961
A10	08672-60163	6	2	ALC BOARD ASSEMBLY	20480	08672-60163
A10C1	0160-2620	6	1	CAPACITOR-FXD 2.2UF+-10% 50VDC TA	25000	D2R2G01B50K
A10C2	0180-0197	8		CAPACITOR-FXD 2.2UF+-10% 20VDC TA	56289	150D225X9020A2
A10C3	0180-0197	8		CAPACITOR-FXD 2.2UF+-10% 20VDC TA	56289	150D225X9020A2
A10C4	0160-3079	7		CAPACITOR-FXD .01UF +-20% 100VDC CER	20480	0160-3079
A10C5	0160-3079	7		CAPACITOR-FXD .01UF +-20% 100VDC CER	20480	0160-3079
A10C6	0160-0127	2		CAPACITOR-FXD 1UF +-20% 25VDC CER	20480	0160-0127
A10C7	0160-3079	7		CAPACITOR-FXD .01UF +-20% 100VDC CER	20480	0160-3079
A10C8	0160-0127	2		CAPACITOR-FXD 1UF +-20% 25VDC CER	20480	0160-0127
A10C9	0160-4764	1		CAPACITOR-FXD 150PF +-5% 100VDC CER	20480	0160-4764
A10C10	0160-3079	7		CAPACITOR-FXD .01UF +-20% 100VDC CER	20480	0160-3079
A10C11	0160-3079	7		CAPACITOR-FXD .01UF +-20% 100VDC CER	20480	0160-3079
A10C12	0160-3079	7		CAPACITOR-FXD .01UF +-20% 100VDC CER	20480	0160-3079
A10C13	0180-0197	8		CAPACITOR-FXD 2.2UF+-10% 20VDC TA	56289	150D225X9020A2
A10C14	0160-4767	4	2	CAPACITOR-FXD 20PF +-5% 200VDC CER 0+-30	20480	0160-4767
A10C15	0160-3447	5	1	CAPACITOR-FXD 470PF +-10% 1KVDC CER	20480	0160-3447
A10C16	0160-3079	7		CAPACITOR-FXD .01UF +-20% 100VDC CER	20480	0160-3079
A10C17	0160-0127	2		CAPACITOR-FXD 1UF +-20% 25VDC CER	20480	0160-0127
A10C18	0160-3079	7		CAPACITOR-FXD .01UF +-20% 100VDC CER	20480	0160-3079
A10C19	0160-3079	7		CAPACITOR-FXD .01UF +-20% 100VDC CER	20480	0160-3079
A10C20	0160-3079	7		CAPACITOR-FXD .01UF +-20% 100VDC CER	20480	0160-3079
A10C21	0180-0491	5	2	CAPACITOR-FXD 10UF+-20% 25VDC TA	20480	0180-0491
A10C22	0160-3079	7		CAPACITOR-FXD .01UF +-20% 100VDC CER	20480	0160-3079
A10C23	0160-3079	7		CAPACITOR-FXD .01UF +-20% 100VDC CER	20480	0160-3079
A10C24	0160-3079	7		CAPACITOR-FXD .01UF +-20% 100VDC CER	20480	0160-3079
A10C25	0160-3079	7		CAPACITOR-FXD .01UF +-20% 100VDC CER	20480	0160-3079

See introduction to this section for ordering information
 *Indicates factory selected value

Table 6-3. Replaceable Parts

Reference Designation	HP Part Number	C D	Qty	Description	Mfr Code	Mfr Part Number
A10C26	0160-3879	7		CAPACITOR-FXD .01UF +-20% 100VDC CER	28480	0160-3879
A10C27	0160-3879	7		CAPACITOR-FXD .01UF +-20% 100VDC CER	28480	0160-3879
A10C28	0160-3879	7		CAPACITOR-FXD .01UF +-20% 100VDC CER	28480	0160-3879
A10C29	0160-3879	7		CAPACITOR-FXD .01UF +-20% 100VDC CER	28480	0160-3879
A10C30	0160-8576	5		CAPACITOR-FXD .1UF +-20% 50VDC CER	28480	0160-8576
A10C31	0160-3879	7		CAPACITOR-FXD .01UF +-20% 100VDC CER	28480	0160-3879
A10C32	0160-3879	7		CAPACITOR-FXD .01UF +-20% 100VDC CER	28480	0160-3879
A10C33	0160-3879	7		CAPACITOR-FXD .01UF +-20% 100VDC CER	28480	0160-3879
A10C34	0160-4767	4		CAPACITOR-FXD 20PF +-5% 200VDC CER 0+-30	28480	0160-4767
A10C35	0160-3879	7		CAPACITOR-FXD .01UF +-20% 100VDC CER	28480	0160-3879
A10C36	0160-3879	7		CAPACITOR-FXD .01UF +-20% 100VDC CER	28480	0160-3879
A10C37	0160-3879	7		CAPACITOR-FXD .01UF +-20% 100VDC CER	28480	0160-3879
A10C38	0160-3879	7		CAPACITOR-FXD .01UF +-20% 100VDC CER	28480	0160-3879
A10C39	0160-3879	7		CAPACITOR-FXD .01UF +-20% 100VDC CER	28480	0160-3879
A10C40	0160-3879	7		CAPACITOR-FXD .01UF +-20% 100VDC CER	28480	0160-3879
A10C41	0160-0157	8	1	CAPACITOR-FXD 4700PF +-10% 200VDC POLYE	28480	0160-0157
A10C42	0180-0491	5		CAPACITOR-FXD 10UF+-20% 25VDC TA	28480	0180-0491
A10C43	0160-3879	7		CAPACITOR-FXD .01UF +-20% 100VDC CER	28480	0160-3879
A10C44	0180-0291	3		CAPACITOR-FXD 1UF+-10% 35VDC TA	56239	1580185X9035A2
A10C45	0180-2815	1	1	CAPACITOR-FXD 100UF+-20% 10VDC TA	28480	0180-2815
A10C46	0160-8574	3	1	CAPACITOR-FXD .022UF +-20% 100VDC CER	28480	0160-8574
A10C47	0160-0127	2		CAPACITOR-FXD 1UF +-20% 25VDC CER	28480	0160-0127
A10CR1	1901-0050	3		DIODE--SWITCHING 80V 200MA 2NS DO-35	28480	1901-0050
A10CR2	1901-0539	3	1	DIODE--SM SIG SCHOTTKY	28480	1901-0539
A10CR3	1901-0033	2	6	DIODE--GEN PRP 180V 200MA DO-7	28480	1901-0033
A10CR4	1901-0033	2		DIODE--GEN PRP 180V 200MA DO-7	28480	1901-0033
A10CR5	1901-0033	2		DIODE--GEN PRP 180V 200MA DO-7	28480	1901-0033
A10CR6	1901-0033	2		DIODE--GEN PRP 180V 200MA DO-7	28480	1901-0033
A10CR7	1901-0050	3		DIODE--SWITCHING 80V 200MA 2NS DO-35	28480	1901-0050
A10CR8	1901-0033	2		DIODE--GEN PRP 180V 200MA DO-7	28480	1901-0033
A10CR9	1901-0050	3		DIODE--SWITCHING 80V 200MA 2NS DO-35	28480	1901-0050
A10CR10	1901-0033	2		DIODE--GEN PRP 180V 200MA DO-7	28480	1901-0033
A10J1	1251-7727	6	1	CONNECTOR-- 7 PIN	28480	1251-7727
A10J2	1250-0835	1		CONNECTOR--RF SMC M PC 50-OHM	28480	1250-0835
A10J3	1250-0835	1		CONNECTOR--RF SMC M PC 50-OHM	28480	1250-0835
A10J4	1251-7730	1		CONNECTOR-- 11 PIN	28480	1251-7730
A10L1	9140-0210	1		INDUCTOR RF--CH-MLD 100UH 5% .166DX.305LG	28480	9140-0210
A10MP1	86701-00048	0	2	BRACKET	28480	86701-00048
A10MP2	86701-00048	0		BRACKET	28480	86701-00048
A10MP3	2200-0101	0	2	SCREW--MACH 4-40 .188-IN-LG PAN--HD--POZI	80000	ORDER BY DESCRIPTION
A10MP4	2200-0101	0		SCREW--MACH 4-40 .188-IN-LG PAN--HD--POZI	80000	ORDER BY DESCRIPTION
A10Q1	1853-0459	3	5	TRANSISTOR PNP SI PD=625MW FT=200MHZ	28480	1853-0459
A10Q2	1854-0810	2		TRANSISTOR NPN SI PD=625MW FT=200MHZ	28480	1854-0810
A10Q3	1853-0459	3		TRANSISTOR PNP SI PD=625MW FT=200MHZ	28480	1853-0459
A10Q4	1854-0810	2		TRANSISTOR NPN SI PD=625MW FT=200MHZ	28480	1854-0810
A10Q5	1853-0459	3		TRANSISTOR PNP SI PD=625MW FT=200MHZ	28480	1853-0459
A10Q6	1854-0810	2		TRANSISTOR NPN SI PD=625MW FT=200MHZ	28480	1854-0810
A10Q7	1855-0395	0	3	TRANSISTOR J-FET N-CHAN D-MODE TO-52 SI	17856	FN2645
A10Q8	1855-0395	0		TRANSISTOR J-FET N-CHAN D-MODE TO-52 SI	17856	FN2645
A10Q9	1855-0395	0		TRANSISTOR J-FET N-CHAN D-MODE TO-52 SI	17856	FN2645
A10Q10	1854-0810	2		TRANSISTOR NPN SI PD=625MW FT=200MHZ	28480	1854-0810
A10Q11	1854-0810	2		TRANSISTOR NPN SI PD=625MW FT=200MHZ	28480	1854-0810
A10Q12	1853-0388	7	2	TRANSISTOR--DUAL PNP PD=600MW	28480	1853-0388
A10Q13	1853-0388	7		TRANSISTOR--DUAL PNP PD=600MW	28480	1853-0388
A10Q14	1854-0810	2		TRANSISTOR NPN SI PD=625MW FT=200MHZ	28480	1854-0810
A10Q15	1854-0810	2		TRANSISTOR NPN SI PD=625MW FT=200MHZ	28480	1854-0810
A10Q16	1854-0810	2		TRANSISTOR NPN SI PD=625MW FT=200MHZ	28480	1854-0810
A10Q17	1855-0414	4	1	TRANSISTOR J-FET 2N4393 N-CHAN D-MODE	04713	2N4393
A10Q18	1853-0459	3		TRANSISTOR PNP SI PD=625MW FT=200MHZ	28480	1853-0459
A10Q19	1853-0459	3		TRANSISTOR PNP SI PD=625MW FT=200MHZ	28480	1853-0459
A10R1	0698-8821	8	1	RESISTOR 5.62 1% .125W F TC=0+-100	28480	0698-8821
A10R2	0757-0346	2		RESISTOR 10 1% .125W F TC=0+-100	24546	C4-1/8-T0-10R0-F
A10R3	0757-0394	0	1	RESISTOR 51.1 1% .125W F TC=0+-100	24546	C4-1/8-T0-51R1-F
A10R4	0757-0443	0	2	RESISTOR 11K 1% .125W F TC=0+-100	24546	C4-1/8-T0-11K2-F
A10R5	1810-0368	3	1	NETWORK--RES 6-SIP10.0K OHM X 5	01121	286A103
A10R6	0698-3450	9	5	RESISTOR 42.2K 1% .125W F TC=0+-100	24546	C4-1/8-T0-4222-F
A10R7	0757-0442	9	13	RESISTOR 16K 1% .125W F TC=0+-100	24546	C4-1/8-T0-1002-F
A10R8	0698-0083	8	5	RESISTOR 1.96K 1% .125W F TC=0+-100	24546	C4-1/8-T0-1961-F
A10R9	0757-0346	2		RESISTOR 10 1% .125W F TC=0+-100	24546	C4-1/8-T0-10R0-F
A10R10	0757-0346	2		RESISTOR 10 1% .125W F TC=0+-100	24546	C4-1/8-T0-10R0-F
A10R11	0698-3152	8	3	RESISTOR 3.40K 1% .125W F TC=0+-100	24546	C4-1/8-T0-3401-F
A10R12	0698-3152	8		RESISTOR 3.40K 1% .125W F TC=0+-100	24546	C4-1/8-T0-3401-F
A10R13	2100-2039	5	1	RESISTOR--TRMR 20K 5% WM SIDE--ADJ 10--TRN	28480	2100-2039
A10R14	0698-0083	8		RESISTOR 1.96K 1% .125W F TC=0+-100	24546	C4-1/8-T0-1961-F
A10R15	0757-0442	9		RESISTOR 10K 1% .125W F TC=0+-100	24546	C4-1/8-T0-1002-F

See introduction to this section for ordering information
 *Indicates factory selected value

Table 6-3. Replaceable Parts

Reference Designation	HP Part Number	C D	Qty	Description	Mfr Code	Mfr Part Number
A10R16	0757-0317	7	1	RESISTOR 1.33K 1% .125W F TC=0+-100	24546	C4-1/8-T0-1331-F
A10R17	0698-0093	8		RESISTOR 1.96K 1% .125W F TC=0+-100	24546	C4-1/8-T0-1961-F
A10R18	0757-0401	0		RESISTOR 100 1% .125W F TC=0+-100	24546	C4-1/8-T0-101-F
A10R19	0757-0346	2		RESISTOR 10 1% .125W F TC=0+-100	24546	C4-1/8-T0-10R0-F
A10R20	0757-0346	2		RESISTOR 10 1% .125W F TC=0+-100	24546	C4-1/8-T0-10R0-F
A10R21	0757-0442	9		RESISTOR 10K 1% .125W F TC=0+-100	24546	C4-1/8-T0-1002-F
A10R22	2100-3164	7	1	RESISTOR-TRMR 10 20% C SIDE-ADJ 17-TRN	02111	43P100
A10R23	0757-0274	5	1	RESISTOR 1.21K 1% .125W F TC=0+-100	24546	C4-1/8-T0-1211-F
A10R24	0757-0463	4	2	RESISTOR 82.5K 1% .125W F TC=0+-100	24546	C4-1/8-T0-8252-F
A10R25	0757-0402	1	1	RESISTOR 110 1% .125W F TC=0+-100	24546	C4-1/8-T0-111-F
A10R26	0757-0463	4		RESISTOR 82.5K 1% .125W F TC=0+-100	24546	C4-1/8-T0-8252-F
A10R27	2100-1922	3	1	RESISTOR-TRMR 5K 10% C SIDE-ADJ 22-TRN	32997	3059Y-1-502
A10R28	0698-3158	4	2	RESISTOR 23.7K 1% .125W F TC=0+-100	24546	C4-1/8-T0-2372-F
A10R29	0757-0346	2		RESISTOR 10 1% .125W F TC=0+-100	24546	C4-1/8-T0-10R0-F
A10R30	0757-0279	0	3	RESISTOR 3.16K 1% .125W F TC=0+-100	24546	C4-1/8-T0-3161-F
A10R31	0698-3152	8		RESISTOR 3.48K 1% .125W F TC=0+-100	24546	C4-1/8-T0-3481-F
A10R32	2100-3273	1	1	RESISTOR-TRMR 2K 10% C SIDE-ADJ 17-TRN	20400	2100-3273
A10R33	0698-5674	3	1	RESISTOR 5.62K 1% .125W F TC=0+-25	20400	0698-5674
A10R34	0698-3154	0	1	RESISTOR 4.22K 1% .125W F TC=0+-100	24546	C4-1/8-T0-4221-F
A10R35	2100-3003	1	1	RESISTOR-TRMR 500 10% C TOP-ADJ 17-TRN	32997	3299W-1-501
A10R36	0698-4432	9	1	RESISTOR 2.1K 1% .125W F TC=0+-100	24546	C4-1/8-T0-2101-F
A10R37	2100-3054	6	1	RESISTOR-TRMR 50K 10% C SIDE-ADJ 17-TRN	02111	43P503
A10R38	0757-0279	0		RESISTOR 3.16K 1% .125W F TC=0+-100	24546	C4-1/8-T0-3161-F
A10R39	0698-8638	5	5	RESISTOR 3.16K 1% .125W F TC=0+-25	20400	0698-8638
A10R40	0698-4426	1	2	RESISTOR 1.58K 1% .125W F TC=0+-100	24546	C4-1/8-T0-1581-F
A10R41	0757-0346	2		RESISTOR 10 1% .125W F TC=0+-100	24546	C4-1/8-T0-10R0-F
A10R42	0757-0346	2		RESISTOR 10 1% .125W F TC=0+-100	24546	C4-1/8-T0-10R0-F
A10R43	0698-8625	0	3	RESISTOR 1K .1% .1W F TC=0+-5	20400	0698-8625
A10R44	0757-0346	2		RESISTOR 10 1% .125W F TC=0+-100	24546	C4-1/8-T0-10R0-F
A10R45	0757-0346	2		RESISTOR 10 1% .125W F TC=0+-100	24546	C4-1/8-T0-10R0-F
A10R46	0698-8625	0		RESISTOR 1K .1% .1W F TC=0+-5	20400	0698-8625
A10R47	0698-4447	6	1	RESISTOR 200 1% .125W F TC=0+-100	24546	C4-1/8-T0-200R-F
A10R48	0698-8638	5		RESISTOR 3.16K 1% .125W F TC=0+-25	20400	0698-8638
A10R49	0698-4426	1		RESISTOR 1.58K 1% .125W F TC=0+-100	24546	C4-1/8-T0-1581-F
A10R50	0757-0279	0		RESISTOR 3.16K 1% .125W F TC=0+-100	24546	C4-1/8-T0-3161-F
A10R51	0698-8625	0		RESISTOR 1K .1% .1W F TC=0+-5	20400	0698-8625
A10R52	0698-8638	5		RESISTOR 3.16K 1% .125W F TC=0+-25	20400	0698-8638
A10R53	0698-0085	0	1	RESISTOR 2.61K 1% .125W F TC=0+-100	24546	C4-1/8-T0-2611-F
A10R54	0698-3447	4		RESISTOR 422 1% .125W F TC=0+-100	24546	C4-1/8-T0-422R-F
A10R55	0698-8638	5		RESISTOR 3.16K 1% .125W F TC=0+-25	20400	0698-8638
A10R56	0757-0465	6	5	RESISTOR 100K 1% .125W F TC=0+-100	24546	C4-1/8-T0-1003-F
A10R57	0757-0465	6		RESISTOR 100K 1% .125W F TC=0+-100	24546	C4-1/8-T0-1003-F
A10R58	2100-3659	7	1	RESISTOR-TRMR 20K 10% C TOP-ADJ 17-TRN	32997	3292W-1-203
A10R59	0699-0722	4	1	RESISTOR 23.7K .1% .125W F TC=0+-25	20400	0699-0722
A10R60	0757-0447	4	1	RESISTOR 16.2K 1% .125W F TC=0+-100	24546	C4-1/8-T0-1622-F
A10R61	0698-3432	7	1	RESISTOR 26.1 1% .125W F TC=0+-100	03000	PM555-1/8-T0-26R1-F
A10R62	2100-3354	9	2	RESISTOR-TRMR 50K 10% C SIDE-ADJ 17-TRN	20400	2100-3354
A10R63	0757-0346	2		RESISTOR 10 1% .125W F TC=0+-100	24546	C4-1/8-T0-10R0-F
A10R64	0757-0346	2		RESISTOR 10 1% .125W F TC=0+-100	24546	C4-1/8-T0-10R0-F
A10R65	0757-0346	2		RESISTOR 10 1% .125W F TC=0+-100	24546	C4-1/8-T0-10R0-F
A10R66	0757-0443	0		RESISTOR 11K 1% .125W F TC=0+-100	24546	C4-1/8-T0-1102-F
A10R67	0757-0200	7	2	RESISTOR 5.62K 1% .125W F TC=0+-100	24546	C4-1/8-T0-5621-F
A10R68	0757-0464	5	1	RESISTOR 90.9K 1% .125W F TC=0+-100	24546	C4-1/8-T0-9092-F
A10R69	0757-0200	3		RESISTOR 1K 1% .125W F TC=0+-100	24546	C4-1/8-T0-1001-F
A10R70	0757-0200	3		RESISTOR 1K 1% .125W F TC=0+-100	24546	C4-1/8-T0-1001-F
A10R71	0698-3158	4		RESISTOR 23.7K 1% .125W F TC=0+-100	24546	C4-1/8-T0-2372-F
A10R72	0698-8556	6	2	RESISTOR 1.62K 1% .125W F TC=0+-10	20400	0698-8556
A10R73	0698-8556	6		RESISTOR 1.62K 1% .125W F TC=0+-10	20400	0698-8556
A10R74	0698-6531	3	1	RESISTOR 350K .1% .125W F TC=0+-25	20400	0698-6531
A10R75	0698-4125	7	1	RESISTOR 953 1% .125W F TC=0+-100	24546	C4-1/8-T0-953R-F
A10R76	0698-8584	0	1	RESISTOR 274 1% .125W F TC=0+-25	20400	0698-8584
A10R77	0757-0442	9		RESISTOR 10K 1% .125W F TC=0+-100	24546	C4-1/8-T0-1002-F
A10R78	0757-0346	2		RESISTOR 10 1% .125W F TC=0+-100	24546	C4-1/8-T0-10R0-F
A10R79	0811-2031	2	1	RESISTOR 815 3% .25W PWM TC=+5900+-300	20400	143-1/4-815K-3
A10R80	0698-3449	6	1	RESISTOR 20.7K 1% .125W F TC=0+-100	24546	C4-1/8-T0-2072-F
A10R81	0757-0419	0	1	RESISTOR 601 1% .125W F TC=0+-100	24546	C4-1/8-T0-601R-F
A10R82	0698-3260	9	1	RESISTOR 464K 1% .125W F TC=0+-100	20400	0698-3260
A10R83	0698-3444	1		RESISTOR 316 1% .125W F TC=0+-100	24546	C4-1/8-T0-316R-F
A10R84	0699-0043	0	1	RESISTOR 2.07K 1% .125W F TC=0+-25	20400	0699-0043
A10R85	0757-0401	0		RESISTOR 100 1% .125W F TC=0+-100	24546	C4-1/8-T0-101-F
A10R86	0698-3151	7		RESISTOR 2.07K 1% .125W F TC=0+-100	24546	C4-1/8-T0-2071-F
A10R87	0757-0444	1		RESISTOR 12.1K 1% .125W F TC=0+-100	24546	C4-1/8-T0-1212-F
A10R88	0757-0290	5	1	RESISTOR 6.19K 1% .125W F TC=0+-100	19701	MF4C1/8-T0-6191-F
A10R89	0757-0346	2		RESISTOR 10 1% .125W F TC=0+-100	24546	C4-1/8-T0-10R0-F
A10R90	0757-0346	2		RESISTOR 10 1% .125W F TC=0+-100	24546	C4-1/8-T0-10R0-F

See introduction to this section for ordering information
 *Indicates factory selected value

Table 6-3. Replaceable Parts

Reference Designation	HP Part Number	C D	Qty	Description	Mfr Code	Mfr Part Number
A10R91	2100-3351	6	1	RESISTOR-TRMR 500 10% C SIDE-ADJ 1-TRN	20480	2100-3351
A10R92	0757-0346	2		RESISTOR 10 1% .125W F TC=0+-100	24546	C4-1/8-T0-10R0-F
A10R93	0757-0346	2		RESISTOR 10 1% .125W F TC=0+-100	24546	C4-1/8-T0-10R0-F
A10R94	0690-3442	9		RESISTOR 237 1% .125W F TC=0+-100	24546	C4-1/8-T0-237R-F
A10R95	0690-3151	7		RESISTOR 2.07K 1% .125W F TC=0+-100	24546	C4-1/8-T0-2071-F
A10R96	0690-0160	6	1	RESISTOR 20.51K 1% .125W F TC=0+-25	19701	MF401/8-T9-20511-B
A10R97	0690-6731	5	1	RESISTOR 3.106K 1% .125W F TC=0+-50	20480	0690-6731
A10R98	0690-0630	5		RESISTOR 3.16K 1% .125W F TC=0+-25	20480	0690-0630
A10R99	0757-0442	9		RESISTOR 10K 1% .125W F TC=0+-100	24546	C4-1/8-T0-1002-F
A10R100	0690-3132	4		RESISTOR 261 1% .125W F TC=0+-100	24546	C4-1/8-T0-2610-F
A10R101	0690-3132	4		RESISTOR 261 1% .125W F TC=0+-100	24546	C4-1/8-T0-2610-F
A10R102	0757-0465	6		RESISTOR 100K 1% .125W F TC=0+-100	24546	C4-1/8-T0-1003-F
A10R103	0757-0458	7	2	RESISTOR 51.1K 1% .125W F TC=0+-100	24546	C4-1/8-T0-5112-F
A10R104	0757-0458	7		RESISTOR 51.1K 1% .125W F TC=0+-100	24546	C4-1/8-T0-5112-F
A10R105	0757-0200	7		RESISTOR 5.62K 1% .125W F TC=0+-100	24546	C4-1/8-T0-5621-F
A10R106	0757-0465	6		RESISTOR 100K 1% .125W F TC=0+-100	24546	C4-1/8-T0-1003-F
A10R107	0690-0003	0		RESISTOR 1.96K 1% .125W F TC=0+-100	24546	C4-1/8-T0-1961-F
A10R108	0757-0270	0	2	RESISTOR 1.70K 1% .125W F TC=0+-100	24546	C4-1/8-T0-1701-F
A10R109	2100-3670	0	1	RESISTOR-TRMR 500K 10% C TOP-ADJ 17-TRN	20480	2100-3670
A10R110	0757-0346	2		RESISTOR 10 1% .125W F TC=0+-100	24546	C4-1/8-T0-10R0-F
A10R111	0757-0270	9		RESISTOR 1.70K 1% .125W F TC=0+-100	24546	C4-1/8-T0-1701-F
A10R112	0690-3132	4		RESISTOR 261 1% .125W F TC=0+-100	24546	C4-1/8-T0-2610-F
A10R113	0757-0346	2		RESISTOR 10 1% .125W F TC=0+-100	24546	C4-1/8-T0-10R0-F
A10R114	0757-0465	6		RESISTOR 100K 1% .125W F TC=0+-100	24546	C4-1/8-T0-1003-F
A10R115	2100-3354	9		RESISTOR-TRMR 50K 10% C SIDE-ADJ 1-TRN	20480	2100-3354
A10R116	0690-3162	0	1	RESISTOR 46.4K 1% .125W F TC=0+-100	24546	C4-1/8-T0-4642-F
A10R117	0757-0200	3		RESISTOR 1K 1% .125W F TC=0+-100	24546	C4-1/8-T0-1001-F
A10R118	0757-0100	2	1	RESISTOR 31.6 1% .125W F TC=0+-100	20480	0757-0100
A10R119	2100-3352	7	1	RESISTOR-TRMR 1K 10% C SIDE-ADJ 1-TRN	20480	2100-3352
A10R120	0757-0346	2		RESISTOR 10 1% .125W F TC=0+-100	24546	C4-1/8-T0-10R0-F
A10R121	0690-0003	0		RESISTOR 1.96K 1% .125W F TC=0+-100	24546	C4-1/8-T0-1961-F
A10RT1	0037-0124	4	1	THERMISTOR DISC 250-OHM TC=-4.4%/C-NEG	20480	0037-0124
A10TP1	1251-0600	0		CONNECTOR-SGL CONT PIN 1.14-MM-BSC-SZ SQ	20480	1251-0600
A10TP2	1251-0600	0		CONNECTOR-SGL CONT PIN 1.14-MM-BSC-SZ SQ	20480	1251-0600
A10TP3	1251-0600	0		CONNECTOR-SGL CONT PIN 1.14-MM-BSC-SZ SQ	20480	1251-0600
A10TP4	1251-0600	0		CONNECTOR-SGL CONT PIN 1.14-MM-BSC-SZ SQ	20480	1251-0600
A10TP5	1251-0600	0		CONNECTOR-SGL CONT PIN 1.14-MM-BSC-SZ SQ	20480	1251-0600
A10TP6	1251-0600	0		CONNECTOR-SGL CONT PIN 1.14-MM-BSC-SZ SQ	20480	1251-0600
A10TP7	1251-0600	0		CONNECTOR-SGL CONT PIN 1.14-MM-BSC-SZ SQ	20480	1251-0600
A10TP8	1251-0600	0		CONNECTOR-SGL CONT PIN 1.14-MM-BSC-SZ SQ	20480	1251-0600
A10TP9	1251-0600	0		CONNECTOR-SGL CONT PIN 1.14-MM-BSC-SZ SQ	20480	1251-0600
A10U1	1020-1112	0		IC FF TTL LS D-TYPE POS-EDGE-TRIG	01295	SN74LS74AN
A10U2	1020-1112	0		IC FF TTL LS D-TYPE POS-EDGE-TRIG	01295	SN74LS74AN
A10U3	1026-0600	9	2	IC OP AMP LOW-BIAS-H-IMPD QUAD 14-DIP-P	01295	TL074ACN
A10U4	1026-0471	2	2	IC OP AMP LOW-DRIFT TO-99 PKG	20480	1026-0471
A10U5	1026-0471	2	2	IC OP AMP LOW-DRIFT TO-99 PKG	20480	1026-0471
A10U6	1026-0547	3	3	IC OP AMP LOW-BIAS-H-IMPD DUAL 8-DIP-P	01295	TL072ACP
A10U7	1026-0100	0	1	IC TIMER TTL MONO/ASTBL	01295	NE555P
A10U8	1020-1201	6	1	IC GATE TTL LS AND QUAD 2-IMP	01295	SN74LS08N
A10U9	1026-0517	7	1	IC CONV 8-B-B/A/D 10-DIP-C PKG	27014	ADC6800PCD
A10U10	1026-0100	0	2	IC CONV 8-B-B/A 16-DIP-C PKG	04713	MC1408L-0
A10U11	1026-0547	3		IC OP AMP LOW-BIAS-H-IMPD DUAL 8-DIP-P	01295	TL072ACP
A10U12	1026-0600	9		IC OP AMP LOW-BIAS-H-IMPD QUAD 14-DIP-P	01295	TL074ACN
A10U13	1020-0125	1	1	IC COMPARTOR CP DUAL TO-100 PKG	07263	711IC
A10U14	1026-0547	3		IC OP AMP LOW-BIAS-H-IMPD DUAL 8-DIP-P	01295	TL072ACP
A10U15	1026-0100	0		IC CONV 8-B-B/A 16-DIP-C PKG	04713	MC1408L-0
A10VR1	1902-0600	7	1	DIODE-ZNR 1N827 6.2V 5% DO-35 PD=.4W	20480	1N827
A10VR2	1902-0943	5	1	DIODE-ZNR 4.3V 5% DO-35 PD=.4W TC=+.017%	20480	1902-0943
A10VR3	1902-0943	1	1	DIODE-ZNR 2.4V 5% DO-35 PD=.4W TC=+.037%	20480	1902-0943
A10VR4	1902-0955	9	1	DIODE-ZNR 7.5V 5% DO-35 PD=.4W TC=+.062%	20480	1902-0955
A10VR5	1902-0950	4	1	DIODE-ZNR 4.7V 5% DO-35 PD=.4W TC=+.025%	20480	1902-0950
A11	00672-60165	0	2	FRONT PANEL BOARD ASSEMBLY	20480	00672-60165
A11C1	0160-4004	0		CAPACITOR-FXD .1UF +-20% 50VDC CER	20480	0160-4004
A11C2	0160-4004	0		CAPACITOR-FXD .1UF +-20% 50VDC CER	20480	0160-4004
A11C3	0160-2055	0		CAPACITOR-FXD .01UF +00-20% 100VDC CER	20480	0160-2055
A11C4	0160-0127	2		CAPACITOR-FXD 1UF +-20% 25VDC CER	20480	0160-0127
A11C5	0160-0127	2		CAPACITOR-FXD 1UF +-20% 25VDC CER	20480	0160-0127
A11C6	0160-2055	9		CAPACITOR-FXD .01UF +00-20% 100VDC CER	20480	0160-2055
A11CR1	1901-0050	3		DIODE-SWITCHING 80V 200MA 2NS DO-35	20480	1901-0050
A11CR2	1901-0050	3		DIODE-SWITCHING 80V 200MA 2NS DO-35	20480	1901-0050

See introduction to this section for ordering information
 *Indicates factory selected value

Table 6-3. Replaceable Parts

Reference Designation	HP Part Number	C D	Qty	Description	Mfr Code	Mfr Part Number
A11D51	1990-0665	3	8	LED-LAMP LUM-INT=1MCD IF=20MA-MAX VVR=5V	28480	1990-0665
A11D52	1990-0665	3		LED-LAMP LUM-INT=1MCD IF=20MA-MAX VVR=5V	28480	1990-0665
A11D53	1990-0665	3		LED-LAMP LUM-INT=1MCD IF=20MA-MAX VVR=5V	28480	1990-0665
A11D54	1990-0665	3		LED-LAMP LUM-INT=1MCD IF=20MA-MAX VVR=5V	28480	1990-0665
A11D55	1990-0665	3		LED-LAMP LUM-INT=1MCD IF=20MA-MAX VVR=5V	28480	1990-0665
A11D56	1990-0665	3	LED-LAMP LUM-INT=1MCD IF=20MA-MAX VVR=5V	28480	1990-0665	
A11D57	1990-0665	3		28480	1990-0665	
A11D58	1990-0665	3		28480	1990-0665	
A11J1	1251-7729	8	CONNECTOR-3 PIN	28480	1251-7729	
A11J2	1251-5316	5		CONNECTOR 34-PIN POST SERIES	28480	1251-5316
A11J3	1251-7730	1		CONNECTOR- 11 PIN	28480	1251-7730
A11K1	0490-1013	6	1	RELAY-REED 1C 250MA 20VDC 5VDC-COIL 3VA	28480	0490-1013
A11Q1	1854-0810	2	TRANSISTOR NPN SI PD=625MW FT=200MHZ	28480	1854-0810	
A11Q2	1854-0810	2		28480	1854-0810	
A11Q3	1854-0810	2		28480	1854-0810	
A11Q4	1854-0810	2		28480	1854-0810	
A11Q5	1854-0810	2		28480	1854-0810	
A11R1	0698-3444	1	RESISTOR 316 1% .125W F TC=0+-100	24546	C4-1/8-T0-316R-F	
A11R2	0757-0442	9		RESISTOR 10K 1% .125W F TC=0+-100	24546	C4-1/8-T0-1002-F
A11R3				NOT ASSIGNED		
A11R4				NOT ASSIGNED		
A11R5	0757-0346	2		RESISTOR 10 1% .125W F TC=0+-100	24546	C4-1/8-T0-10R0-F
A11R6	0757-0442	9		RESISTOR 10K 1% .125W F TC=0+-100	24546	C4-1/8-T0-1002-F
A11R7	0757-0442	9		RESISTOR 10K 1% .125W F TC=0+-100	24546	C4-1/8-T0-1002-F
A11R8	0698-3450	9		RESISTOR 42.2K 1% .125W F TC=0+-100	24546	C4-1/8-T0-4222-F
A11R9	0698-3450	9		RESISTOR 42.2K 1% .125W F TC=0+-100	24546	C4-1/8-T0-4222-F
A11R10	0698-3450	9		RESISTOR 42.2K 1% .125W F TC=0+-100	24546	C4-1/8-T0-4222-F
A11R11	0698-3450	9		RESISTOR 42.2K 1% .125W F TC=0+-100	24546	C4-1/8-T0-4222-F
A11R12	0757-0442	9		RESISTOR 10K 1% .125W F TC=0+-100	24546	C4-1/8-T0-1002-F
A11R13	0757-0442	9		RESISTOR 10K 1% .125W F TC=0+-100	24546	C4-1/8-T0-1002-F
A11R14	0757-0442	9		RESISTOR 10K 1% .125W F TC=0+-100	24546	C4-1/8-T0-1002-F
A11R15	0698-3447	4		RESISTOR 422 1% .125W F TC=0+-100	24546	C4-1/8-T0-422R-F
A11R16	0698-3444	1	RESISTOR 316 1% .125W F TC=0+-100	24546	C4-1/8-T0-316R-F	
A11R17	0757-0442	9	RESISTOR 10K 1% .125W F TC=0+-100	24546	C4-1/8-T0-1002-F	
A11R18	0757-0442	9	RESISTOR 10K 1% .125W F TC=0+-100	24546	C4-1/8-T0-1002-F	
A11R19	0757-0199	3	RESISTOR 21.5K 1% .125W F TC=0+-100	24546	C4-1/8-T0-2152-F	
A11R20	0698-3447	4	RESISTOR 422 1% .125W F TC=0+-100	24546	C4-1/8-T0-422R-F	
A11R21	0698-3444	1	RESISTOR 316 1% .125W F TC=0+-100	24546	C4-1/8-T0-316R-F	
A11R22	0698-3444	1	RESISTOR 316 1% .125W F TC=0+-100	24546	C4-1/8-T0-316R-F	
A11S1	5060-9436	7	3	PUSHBUTTON SWITCH P.C. MOUNT	28480	5060-9436
A11S2	5060-9436	7		PUSHBUTTON SWITCH P.C. MOUNT	28480	5060-9436
A11S3	5060-9436	7		PUSHBUTTON SWITCH P.C. MOUNT	28480	5060-9436
A11U1	1820-1301	7	1	IC MIXR/DATA-SEL TTL S 2-T0-1-LINE QUAD	91295	SN74LS257N
A11U2	1820-1423	4	1	IC MV TTL LS MONOSTBL RETRIC DUAL	01295	SN74LS123N
A12	0960-0443	1	1	POWER MODULE/LINE FILTER	28480	0960-0443
CHASSIS PARTS						
A1	08672-60175	0	1	PULSE DRIVER BOARD ASSEMBLY EXCEPT OPT. 009, 010	28480	08672-60175
A2	0672A-60104	7		DRIVER BOARD ASSEMBLY	28480	0672A-60104
A3	11713-60003	0		LATCH BOARD ASSEMBLY	28480	11713-60003
A4	11713-60004	1		LOGIC BOARD ASSEMBLY	28480	11713-60004
A5	11713-60005	2		HP-IB BOARD ASSEMBLY	28480	11713-60005
A6	08672-60168	1		MOTHER SWITCH BOARD ASSEMBLY	28480	08672-60168
A7	08672-60164	7		REAR INTERFACE BOARD ASSEMBLY	28480	08672-60164
A8	08672-60169	2		HP-IB BOARD ASSEMBLY	28480	08672-60169
A9	08672-60166	9	POWER SUPPLY BOARD ASSEMBLY	28480	08672-60166	
A10	08672-60163	6	ALC BOARD ASSEMBLY	28480	08672-60163	
A11	08672-60165	8	FRONT PANEL BOARD ASSEMBLY	28480	08672-60165	
AR1	5086-7390	2	1	AMPLIFIER-RF	28480	5086-7390
AT1	0960-0053	9	3	TERMINATION EXCEPT OPT. 009, 010	28480	0960-0053
AT2	11720-60010	8		MODULATOR-PIN DIODE EXCEPT OPT. 009, 010	28480	11720-60010
AT3	11720-00012	4		LABEL-DIODE (NSR-P/D AT2)	28480	11720-00012
AT4	0960-0053	9		TERMINATION EXCEPT OPT. 009, 010	28480	0960-0053
AT5	0960-0472	6	1	ISOLATOR-2 PORT	28480	0960-0472
ATS	0955-0160	8	1	DIODE-SWITCH EXCEPT OPT. 009, 010	28480	0955-0160
AT6	0955-0107	3	1	SWITCH-MICROWAVE	28480	0955-0107
AT7	08672-60160	3	1	SMA COAX ATTENUATOR	28480	08672-60160
AT8	0960-0053	9	TERMINATION EXCEPT OPT. 009, 010	28480	0960-0053	

See introduction to this section for ordering information
 *Indicates factory selected value

Table 6-3. Replaceable Parts

Reference Designation	HP Part Number	C D	Qty	Description	Mfr Code	Mfr Part Number
AT9	08672-60146	5	1	ATTENUATOR ASSEMBLY-110 DB EXCEPT OPT. 001, 005, 010	28480	08672-60146
B1	3160-0263	0	1	BLOWER-CNTFGL 24-CFM 115V 50/60-HZ	28480	3160-0263
C1	0180-2181	4	4	CAPACITOR-FXD 1300UF+75-10% 50VDC AL	00653	539-7471-02
C2	0180-2181	4	4	CAPACITOR-FXD 1300UF+75-10% 50VDC AL EXCEPT OPT. 009, 010	00653	539-7471-02
C3	0180-2181	4	4	CAPACITOR-FXD 1300UF+75-10% 50VDC AL	00653	539-7471-02
C4	0180-2221	3	1	CAPACITOR-FXD 7200UF+75-10% 15VDC AL	28480	0180-2221
C5	0180-2181	4	4	CAPACITOR-FXD 1300UF+75-10% 50VDC AL	00653	539-7471-02
C6	0160-4065	5	1	CAPACITOR-FXD .1UF +-20% 250VAC(RMS)	28480	0160-4065
C7	0180-0291	3	3	CAPACITOR-FXD 1UF+-10% 35VDC TA	56289	150D105X9035A2
C8	0180-0291	3	3	CAPACITOR-FXD 1UF+-10% 35VDC TA	56289	150D105X9035A2
C9	0180-0089	7	1	CAPACITOR-FXD 10UF+50-10% 150VDC AL	56289	30D106F150D02
CP1	11720-60002	8	2	BIAS TEE ASSEMBLY EXCEPT OPT. 009, 010	28480	11720-60002
CP2	11720-60002	8	2	BIAS TEE ASSEMBLY EXCEPT OPT 009, 010	28480	11720-60002
CR1	08672-60129	4	1	CRYSTAL DETECTOR	28480	08672-60129
DC1	0955-0165	3	1	COUPLER-23DB	28480	0955-0165
F1	2110-0001	0	1	FUSE 1A 250V NTD 1.25X.25 UL (FOR 100/120V OPERATION)	75915	312001
F1	2110-0063	2	1	FUSE .75A 250V NTD 1.25X.25 UL (FOR 220/240V OPERATION)	28480	2110-0063
FL1	11720-60009	5	2	LOW PASS FILTER ASSEMBLY EXCEPT OPT. 009, 010	28480	11720-60009
FL2	11720-60003	9	2	HIGH PASS FILTER ASSEMBLY EXCEPT OPT. 009, 010	28480	11720-60003
FL3	11720-60009	5	5	LOW PASS FILTER ASSEMBLY EXCEPT OPT. 009, 010	28480	11720-60009
FL4	11720-60003	9	9	HIGH PASS FILTER ASSEMBLY EXCEPT OPT. 009, 010	28480	11720-60003
FL5	9135-0169	0	1	FILTER-4.5 GHZ	28480	9135-0169
FL6	9135-0198	3	1	FILTER-LOW PASS	28480	9135-0198
G1	0955-0164	2	1	OSCILLATOR-4.2 GHZ	28480	0955-0164
J1	08672-60132	9	2	CONNECTOR ASSEMBLY	28480	08672-60132
J2	08672-60132	9	2	CONNECTOR ASSEMBLY	28480	08672-60132
J3	1250-1091	3	1	CONNECTOR-RF SMC FEM SGL-HOLE-RR 50-OHM P/D OF W39	28480	1250-1091
J4	1250-0102	5	1	CONNECTOR-RF SMC FEM SGL-HOLE-FR 50-OHM	28480	1250-0102
K1	08672-60142	1	2	SWITCH ASSEMBLY-5PT EXCEPT OPT. 009, 010	28480	08672-60142
K2	08672-60142	1	1	SWITCH ASSEMBLY-5PT	28480	08672-60142
M1	1120-1594	6	1	METER	28480	1120-1594
MP1	1600-0367	7	2	VERTICAL LOCK (FRONT)	28480	1600-0367
MP2	1600-0367	7	2	VERTICAL LOCK (FRONT)	28480	1600-0367
MP3	0050-0517	1	2	VERTICAL LOCK (REAR)	28480	0050-0517
MP4	0050-0517	1	1	VERTICAL LOCK (REAR)	28480	0050-0517
MP5	5060-9901	1	2	HANDLE ASSEMBLY	28480	5060-9901
MP6	5060-9901	1	1	HANDLE ASSEMBLY	28480	5060-9901
MP7	5020-8898	9	2	HANDLE TRIM (PLASTIC)	28480	5020-8898
MP8	5020-8898	9	9	HANDLE TRIM (PLASTIC)	28480	5020-8898
MP9-						
MP12	5040-7221	2	4	FEET (REAR)	28480	5040-7221
MP13-						
MP16	2360-0330	5	4	SCREW-MACH 6-32 .188-IN-LG PAN-HD-POZI	28480	2360-0330
MP17-						
MP20	2360-0334	9	4	SCREW-MACH 6-32 .312-IN-LG 100 DFG	28480	2360-0334
MP21-						
MP26	2510-0195	9	12	SCREW-MACH 0-32 .375-IN-LG 100 DEG	28480	2510-0195
MP27-						
MP30	2360-0195	0	4	SCREW-MACH 6-32 .312-IN-LG PAN-HD-POZI	28480	2360-0195
MP31-						
MP49				NOT ASSIGNED		
MP50	5020-8801	4	1	FRAME-FRONT	28480	5020-8801
MP51	5020-8802	5	1	FRAME-REAR	28480	5020-8802
MP52	5020-8833	2	2	SIDE STRUT	28480	5020-8833
MP53	5020-8833	2	2	SIDE STRUT	28480	5020-8833
MP54	5060-9877	0	2	COVER (SIDE) W/HANDLE	28480	5060-9877
MP55	5060-9877	0	0	COVER (SIDE) W/HANDLE	28480	5060-9877
MP56	08672-00105	0	1	COVER (TOP) 21"	28480	08672-00105
MP57	5060-9848	5	1	COVER (BOTTOM) 21 FM	28480	5060-9848
MP58	5060-9805	4	2	STRAP-HANDLE 21"	28480	5060-9805
MP59	5060-9805	4	4	STRAP-HANDLE 21"	28480	5060-9805
MP60	5040-7220	1	2	HANDLE-CAP (REAR)	28480	5040-7220

See introduction to this section for ordering information
 *Indicates factory selected value

Table 6-3. Replaceable Parts

Reference Designation	HP Part Number	C D	Qty	Description	Mfr Code	Mfr Part Number
MP61	5040-7220	1		HANDLE-CAP (REAR)	28480	5040-7220
MP62	5040-7219	8	2	HANDLE-CAP (FRONT)	28480	5040-7219
MP63	5040-7219	8		HANDLE-CAP (FRONT)	28480	5040-7219
MP64	5040-7201	8	4	FOOT-FULL-1/2 MOD	28480	5040-7201
MP65	5040-7201	8		FOOT-FULL-1/2 MOD	28480	5040-7201
MP66	5040-7201	8		FOOT-FULL-1/2 MOD	28480	5040-7201
MP67	5040-7201	8		FOOT-FULL-1/2 MOD	28480	5040-7201
MP68	1460-1345	5	2	TILT STAND SST	28480	1460-1345
MP69	1460-1345	5		TILT STAND SST	28480	1460-1345
MP70	08672-00083	3	1	PANEL (REAR)	28480	08672-00083
MP71	08672-00084	4	1	DECK-MAIN	28480	08672-00084
MP72	08672-00086	6	1	BRACKET-ATTENUATOR	28480	08672-00086
MP73	08672-00089	2	1	STRUT (CENTER)	28480	08672-00089
MP74	08672-00090	2	1	SUPPORT-REGULATOR BOARD	28480	08672-00090
MP75	08672-00091	3	1	SHROUD-FAN	28480	08672-00091
MP76	08672-00095	7	1	BRACKET-MODULATOR	28480	08672-00095
MP77	11720-00004	4	2	SUPPORT-PULSE DRIVER A1 EXCEPT OPT. 009, 010	28480	11720-00004
MP78	11720-00004	4		SUPPORT-PULSE DRIVER A1	28480	11720-00004
MP79	11720-00005	5	1	SUPPORT-FRONT EXCEPT OPT. 009, 010	28480	11720-00005
MP80	08672-00093	5	1	BRACKET-BIAS TEE EXCEPT OPT. 009, 010	28480	08672-00093
MP81	11713-00004	5	1	SUPPORT-MOTHER BOARD	28480	11713-00004
MP82	11713-00013	6	1	SUPPORT-TRANSFORMER	28480	11713-00013
MP83-						
MP90	5040-0170	6	8	GUIDE: PLUG-IN PC BOARD	28480	5040-0170
MP91	08672-00097	9	1	SHIM-MIXER (FOR U1)	28480	08672-00097
MP92-				NOT ASSIGNED		
MP98	5061-0074	3	1	RACK FLANGE KIT ONLY OPT. 908	28480	5061-0074
MP99	5061-0091	4	1	FRONT HANDLE KIT	28480	5061-0091
MP101	08672-00082	2	1	PANEL-FRONT SUB	28480	08672-00082
MP102	08672-00080	0	1	PANEL-DRESS STANDARD	28480	08672-00080
MP102	08672-00104	9	1	FRONT PANEL EXCEPT OPT. 004, 005	28480	08672-00104
MP102	08672-00107	2	1	FRONT PANEL EXCEPT OPT. 009, 010	28480	08672-00107
MP103	08672-00087	7	1	PANEL-CONNECTOR (SMALL ON INSIDE , END)	28480	08672-00087
MP104	08672-00050	4	2	CLAMP-METER	28480	08672-00050
MP105	08672-00050	4		CLAMP-METER	28480	08672-00050
MP106	08672-40011	1	1	SCREW-METER ZERO	28480	08672-40011
MP107	0370-2445	6	1	KNOB-BASE 1/2 JCK .125-IN-ID	28480	0370-2445
MP108-						
MP110	5041-0124	2	3	KEY CAP-JADE (FOR A11S1-3)	28480	5041-0124
MP111	00310-40801	0	2	WASHER-SHOULDERED (FOR J3)	28480	00310-40801
MP112	00310-40801	0		WASHER-SHOULDERED (FOR J3)	28480	00310-40801
MP113				NOT ASSIGNED		
MP114-						
MP121	5040-6808	5	8	LIGHT PIPE-12MM	28480	5040-6808
MP122				NOT ASSIGNED		
MP123				NOT ASSIGNED		
MP124	08672-00088	8	1	BRACKET-FRONT PANEL	28480	08672-00088
MP125	08731-210	2	2	NUT LOCK	28480	08731-210
MP126	08731-210	2		NUT LOCK	28480	08731-210
MP127-						
MP129				NOT ASSIGNED		
MP130-						
MP145	2200-0151	0	15	SCREW-MACH 4-40 .75-IN-LG PAN-HD-POZI OPTIONS 009 & 010 ONLY	00000	ORDER BY DESCRIPTION
MP146	2360-0119	8	5	SCREW-MACH 6-32 .438-IN-LG PAN-HD-POZI	00000	ORDER BY DESCRIPTION
MP147	2360-0119	8		SCREW-MACH 6-32 .438-IN-LG PAN-HD-POZI	00000	ORDER BY DESCRIPTION
MP148	2360-0119	8		SCREW-MACH 6-32 .438-IN-LG PAN-HD-POZI	00000	ORDER BY DESCRIPTION
MP149	2360-0119	8		SCREW-MACH 6-32 .438-IN-LG PAN-HD-POZI	00000	ORDER BY DESCRIPTION
MP150	2360-0119	8		SCREW-MACH 6-32 .438-IN-LG PAN-HD-POZI	00000	ORDER BY DESCRIPTION
MP151	2420-0003	7	2	NUT-HEX-DEL-CHAM 6-32-THD .094-IN-THK	28480	2420-0003
MP152	2420-0003	7		NUT-HEX-DEL-CHAM 6-32-THD .094-IN-THK	28480	2420-0003
MP153	2420-0002	6		NUT-HEX-DEL-CHAM 6-32-THD .109-IN-THK	28480	2420-0002
MP154				NOT ASSIGNED		
MP155-						
MP159	2510-0195	9		SCREW-MACH 8-32 .375-IN-LG 100 DEG	28480	2510-0195
MP160-						
MP205				NOT ASSIGNED		
MP206	0360-0036	6	1	TERMINAL-SLDR LUG PL-MTG FOR-#6-SCR	28480	0360-0036
MP207	0360-0053	7	2	TERMINAL-SLDR LUG LK-MTG FOR-#10-SCR	28480	0360-0053
MP208	0360-0053	7		TERMINAL-SLDR LUG LK-MTG FOR-#10-SCR	28480	0360-0053
MP209	0360-1150	5	1	TERMINAL-SLDR LUG PL-MTG FOR-#1/2-SCR	86928	5413-21
MP210	0360-0374	5	1	TERMINAL-SLDR LUG PL-MTG FOR-#4-SCR	79963	9-120
MP211				NOT ASSIGNED		
MP212	0400-0001	1	2	GROMMET-RND .562-IN-ID .75-IN-GRV-OD	28480	0400-0001
MP213	0400-0001	1		GROMMET-RND .562-IN-ID .75-IN-GRV-OD	28480	0400-0001

See introduction to this section for ordering information
 *Indicates factory selected value

Table 6-3. Replaceable Parts

Reference Designation	HP Part Number	C D	Qty	Description	Mfr Code	Mfr Part Number
MP214	0400-0010	2	1	GRDMNET-RND .25-IN-ID .375-IN-GRV-6D	28480	0400-0010
MP215	2190-0017	4	4	WASHER-LK HLCL NO. 8 .168-IN-ID	28480	2190-0017
MP216	2190-0017	4		WASHER-LK HLCL NO. 8 .168-IN-ID	28480	2190-0017
MP217	2190-0017	4		WASHER-LK HLCL NO. 8 .168-IN-ID	28480	2190-0017
MP218	2190-0017	4		WASHER-LK HLCL NO. 8 .168-IN-ID	28480	2190-0017
MP219				NOT ASSIGNED		
MP220	0590-1011	6	1	NUT-KNRLD-R 15/32-32-THD .12-IN-THK	28480	0590-1011
MP221-						
MP232	0624-0305	2	12	SCREW-TPC 6-20 .5-IN-LG PAN-HD-POZI	00000	ORDER BY DESCRIPTION
MP233	1200-0043	8	3	INSULATOR-XSTR ALUMINUM	28480	1200-0043
MP234	1200-0043	8		INSULATOR-XSTR ALUMINUM	28480	1200-0043
MP235	1200-0043	8		INSULATOR-XSTR ALUMINUM	28480	1200-0043
MP236	1250-1741	0	4	ADAPTER-COAX RTANG M-SMA F-SMA	28480	1250-1741
MP237	1250-1741	0		ADAPTER-COAX RTANG M-SMA F-SMA	28480	1250-1741
MP238	1251-4460	8	2	CLIP-CABLE PLUG RTNG-DUAL INLINE 16 CONT	28480	1251-4460
MP239	1251-4460	8		CLIP-CABLE PLUG RTNG-DUAL INLINE 16 CONT	28480	1251-4460
MP240	1400-0510	8	3	CLAMP-CABLE .15-DIA .62-WD NYL	28480	1400-0510
MP241	1400-0510	8		CLAMP-CABLE .15-DIA .62-WD NYL	28480	1400-0510
MP242	1400-0510	8		CLAMP-CABLE .15-DIA .62-WD NYL	28480	1400-0510
MP243	1400-0755	3	1	CLIP-CMPNT .25-DIA .75-WD PVC	06915	KKU-4
MP244				NOT ASSIGNED		
MP245	1400-0757	5	3	CLAMP-CABLE .25-DIA 1-WD PVC	28480	1400-0757
MP246	1400-0757	5		CLAMP-CABLE .25-DIA 1-WD PVC	28480	1400-0757
MP247	1400-0757	5		CLAMP-CABLE .25-DIA 1-WD PVC	28480	1400-0757
MP248	2360-0201	9		SCREW-MACH 6-32 .5-IN-LG PAN-HD-POZI	00000	ORDER BY DESCRIPTION
MP249	2360-0201	9		SCREW-MACH 6-32 .5-IN-LG PAN-HD-POZI	00000	ORDER BY DESCRIPTION
MP250	2190-0004	9	2	WASHER-LK INTL T NO. 4 .115-IN-ID	28480	2190-0004
MP251	2190-0004	9		WASHER-LK INTL T NO. 4 .115-IN-ID	28480	2190-0004
MP252-						
MP266	2190-0006	1		WASHER-LK HLCL NO. 6 .141-IN-ID	28480	2190-0006
MP267	2200-0141	8	2	SCREW-MACH 4-40 .312-IN-LG PAN-HD-POZI	28480	2200-0141
MP268	2200-0141	8		SCREW-MACH 4-40 .312-IN-LG PAN-HD-POZI	28480	2200-0141
MP269-						
MP274	2190-0019	6	6	WASHER-LK HLCL NO. 4 .115-IN-ID	28480	2190-0019
MP275	2190-0068	5	1	WASHER-LK INTL T 1/2 IN .595-IN-ID	28480	2190-0068
MP276	2190-0104	0	2	WASHER-LK INTL T 7/16 IN .439-IN-ID	28480	2190-0104
MP277	2190-0104	0		WASHER-LK INTL T 7/16 IN .439-IN-ID	28480	2190-0104
MP278	2190-0120	0	2	WASHER-LK INTL T 5/8 IN .64-IN-ID	28480	2190-0120
MP279	2190-0120	0		WASHER-LK INTL T 5/8 IN .64-IN-ID	28480	2190-0120
MP280-						
MP305	2200-0103	2	25	SCREW-MACH 4-40 .25-IN-LG PAN-HD-POZI	28480	2200-0103
MP306	2190-0018	5	3	WASHER-LK HLCL NO. 6 .141-IN-ID	28480	2190-0018
MP307	2190-0018	5		WASHER-LK HLCL NO. 6 .141-IN-ID	28480	2190-0018
MP308	2190-0018	5		WASHER-LK HLCL NO. 6 .141-IN-ID	28480	2190-0018
MP309-						
MP314	2200-0107	6		SCREW-MACH 4-40 .375-IN-LG PAN-HD-POZI	00000	ORDER BY DESCRIPTION
MP315	2200-0111	2	2	SCREW-MACH 4-40 .5-IN-LG PAN-HD-POZI	00000	ORDER BY DESCRIPTION
MP316	2200-0111	2		SCREW-MACH 4-40 .5-IN-LG PAN-HD-POZI	00000	ORDER BY DESCRIPTION
MP317	2200-0115	6	2	SCREW-MACH 4-40 .75-IN-LG PAN-HD-POZI	00000	ORDER BY DESCRIPTION
MP318	2200-0115	6		SCREW-MACH 4-40 .75-IN-LG PAN-HD-POZI	00000	ORDER BY DESCRIPTION
MP319	2200-0119	0	2	SCREW-MACH 4-40 1-IN-LG PAN-HD-POZI	00000	ORDER BY DESCRIPTION
MP320	2200-0119	0		SCREW-MACH 4-40 1-IN-LG PAN-HD-POZI	00000	ORDER BY DESCRIPTION
MP321	2200-0121	4	4	SCREW-MACH 4-40 1.125-IN-LG PAN-HD-POZI	00000	ORDER BY DESCRIPTION
MP322	2200-0121	4		SCREW-MACH 4-40 1.125-IN-LG PAN-HD-POZI	00000	ORDER BY DESCRIPTION
MP323	2200-0121	4		SCREW-MACH 4-40 1.125-IN-LG PAN-HD-POZI	00000	ORDER BY DESCRIPTION
MP324	2200-0121	4		SCREW-MACH 4-40 1.125-IN-LG PAN-HD-POZI	00000	ORDER BY DESCRIPTION
MP325	2200-0149	6		SCREW-MACH 4-40 .625-IN-LG PAN-HD-POZI	00000	ORDER BY DESCRIPTION
MP326	2200-0149	6		SCREW-MACH 4-40 .625-IN-LG PAN-HD-POZI	00000	ORDER BY DESCRIPTION
MP327	2200-0180	5	2	SCREW-MACH 4-40 1.375-IN-LG PAN-HD-POZI	00000	ORDER BY DESCRIPTION
MP328	2200-0180	5		SCREW-MACH 4-40 1.375-IN-LG PAN-HD-POZI	00000	ORDER BY DESCRIPTION
MP329	2260-0001	5	2	NUT-HEX-DBL-CHAM 4-40-THD .094-IN-THK	28480	2260-0001
MP330	2260-0001	5		NUT-HEX-DBL-CHAM 4-40-THD .094-IN-THK	28480	2260-0001
MP331	2260-0009	3		NUT-HEX-W/LKWR 4-40-THD .094-IN-THK	00000	ORDER BY DESCRIPTION
MP332	2260-0009	3		NUT-HEX-W/LKWR 4-40-THD .094-IN-THK	00000	ORDER BY DESCRIPTION
MP333	2260-0009	3		NUT-HEX-W/LKWR 4-40-THD .094-IN-THK	00000	ORDER BY DESCRIPTION
MP334	2260-0009	3		NUT-HEX-W/LKWR 4-40-THD .094-IN-THK	00000	ORDER BY DESCRIPTION
MP335	2260-0009	3		NUT-HEX-W/LKWR 4-40-THD .094-IN-THK	00000	ORDER BY DESCRIPTION
MP336	2260-0009	3		NUT-HEX-W/LKWR 4-40-THD .094-IN-THK	00000	ORDER BY DESCRIPTION
MP337-						
MP377	2360-0113	2	40	SCREW-MACH 6-32 .25-IN-LG PAN-HD-POZI	00000	ORDER BY DESCRIPTION
MP378-						
MP380				NOT ASSIGNED		
MP381-						
MP390	2190-0011	8	10	WASHER-LK INTL T NO. 10 .195-IN-ID	28480	2190-0011
MP391-						
MP412	2360-0115	4	22	SCREW-MACH 6-32 .312-IN-LG PAN-HD-POZI	00000	ORDER BY DESCRIPTION
MP413				NOT ASSIGNED		

See introduction to this section for ordering information
 *Indicates factory selected value

Table 6-3. Replaceable Parts

Reference Designation	HP Part Number	C D	Qty	Description	Mfr Code	Mfr Part Number
MP 414				NOT ASSIGNED		
MP 415-						
MP 417	2360-0133	6	3	SCREW-MACH 6-32 1.25-IN-LG PAN-HD-POZI	00000	ORDER BY DESCRIPTION
MP 418-						
MP 426	2360-0190	5	9	SCREW-MACH 6-32 .100-IN-LG 100 DEG	20400	2360-0190
MP 427	2360-0197	2	1	SCREW-MACH 6-32 .375-IN-LG PAN-HD-POZI	20400	2360-0197
MP 428	2360-0199	4	1	SCREW-MACH 6-32 .430-IN-LG PAN-HD-POZI	00000	ORDER BY DESCRIPTION
MP 429	2740-0001	3	2	NUT-HEX-DBL-CHAM 10-32-THD .109-IN-THK	00000	ORDER BY DESCRIPTION
MP 430	2740-0001	3	2	NUT-HEX-DBL-CHAM 10-32-THD .109-IN-THK	00000	ORDER BY DESCRIPTION
MP 431	2510-0049	2	2	SCREW-MACH 8-32 .5-IN-LG PAN-HD-POZI	00000	ORDER BY DESCRIPTION
MP 432	2510-0049	2		SCREW-MACH 8-32 .5-IN-LG PAN-HD-POZI	00000	ORDER BY DESCRIPTION
MP 433	2510-0067	4	2	SCREW-MACH 8-32 2-IN-LG PAN-HD-POZI	00000	ORDER BY DESCRIPTION
MP 434	2510-0067	4		SCREW-MACH 8-32 2-IN-LG PAN-HD-POZI	00000	ORDER BY DESCRIPTION
MP 435-						
MP 437	2360-0121	2	3	SCREW-MACH 6-32 .5-IN-LG PAN-HD-POZI	00000	ORDER BY DESCRIPTION
MP 438-						
MP 444	2360-0117	6	6	SCREW-MACH 6-32 .375-IN-LG PAN-HD-POZI	00000	ORDER BY DESCRIPTION
MP 445	2510-0135	7	2	SCREW-MACH 8-32 2.25-IN-LG PAN-HD-POZI	00000	ORDER BY DESCRIPTION
MP 446	2510-0135	7	2	SCREW-MACH 8-32 2.25-IN-LG PAN-HD-POZI	00000	ORDER BY DESCRIPTION
MP 447-						
MP 450	2510-0192	6	4	SCREW-MACH 8-32 .25-IN-LG 100 DEG	00000	ORDER BY DESCRIPTION
MP 451-						
MP 454	3050-0105	6		WASHER-FL MTLC NO. 4 .125-IN-ID	20400	3050-0105
MP 455-						
MP 460	2600-0003	5	6	NUT-HEX-W/LKWR 8-32-THD .125-IN-THK	00000	ORDER BY DESCRIPTION
MP 461-						
MP 464	2600-0099	1	4	SCREW-MACH 10-32 .375-IN-LG PAN-HD-POZI	00000	ORDER BY DESCRIPTION
MP 465-						
MP 470	2600-0129	8	6	SCREW-MACH 10-32 .312-IN-LG PAN-HD-POZI	00000	ORDER BY DESCRIPTION
MP 471	2950-0043	8	1	NUT-HEX-DBL-CHAM 3/8-32-THD .094-IN-THK	00000	ORDER BY DESCRIPTION
MP 472	2950-0054	1	1	NUT-HEX-DBL-CHAM 1/2-20-THD .125-IN-THK	00000	ORDER BY DESCRIPTION
MP 473	2950-0079	0	2	NUT-HEX-DBL-CHAM 5/8-24-THD .125-IN-THK	20400	2950-0079
MP 474	2950-0079	0		NUT-HEX-DBL-CHAM 5/8-24-THD .125-IN-THK	20400	2950-0079
MP 475	2950-0132	6	2	NUT-HEX-DBL-CHAM 7/16-20-THD .094-IN-THK	00000	ORDER BY DESCRIPTION
MP 476	2950-0132	6	6	NUT-HEX-DBL-CHAM 7/16-20-THD .094-IN-THK	00000	ORDER BY DESCRIPTION
MP 477-						
MP 480	3050-0001	1	4	WASHER-FL MTLC NO. 8 .172-IN-ID	20400	3050-0001
MP 481	3050-0010	2	2	WASHER-FL MTLC NO. 6 .147-IN-ID	20400	3050-0010
MP 482	3050-0010	2		WASHER-FL MTLC NO. 6 .147-IN-ID	20400	3050-0010
MP 483-						
MP 486	3050-0066	8	3	WASHER-FL MTLC NO. 6 .147-IN-ID	20400	3050-0066
MP 487	3050-0005	5	1	WASHER-SHLDR NO. 6 .14-IN-ID .375-IN-OD	20400	3050-0005
MP 488	3050-0155	6	2	WASHER-FL MTLC NO. 6 .156-IN-ID	20400	3050-0155
MP 489	3050-0155	6		WASHER-FL MTLC NO. 6 .156-IN-ID	20400	3050-0155
MP 490				NOT ASSIGNED		
MP 491				NOT ASSIGNED		
MP 492	7120-3528	6	1	LABEL-WARNING .6-IN-WD 1.8-IN-LG VINYL	20400	7120-3528
MP 493	7120-4163	7	2	LABEL ID	20400	7120-4163
MP 494	7120-4163	7		LABEL ID	20400	7120-4163
MP 495	7120-5911	5	1	LABEL-WARNING 1-IN-WD 7-IN-LG PPR	20400	7120-5911
MP 496	7120-8138	4	2	LABEL-WARNING 6-MM-WD 51-MM-LG VINYL	20400	7120-8138
MP 497	7120-8138	4		LABEL-WARNING 6-MM-WD 51-MM-LG VINYL	20400	7120-8138
MP 498	7120-8968	8	1	TAG, INFO	20400	7120-8968
R1	2100-4018	4	1	RESISTOR-VAR CONTROL CP 10K 10% LIN	20400	2100-4018
R2	0018-0037	8	1	RESISTOR 4 32 25W PW TC=0+-50	20400	0018-0037
S1	3101-1912	4	1	SWITCH-TCL SUBMIN DPDT 2A 250VAC	20400	3101-1912
T1	9100-3973	5	1	TRANSFORMER EXCEPT OPT. 009, 010	20400	9100-3973
T2	9100-4000	7	1	TRANSFORMER-POWER 100/120/220/240V	20400	9100-4000
U1	0955-0167	5	1	MIXER-DC 2CHZ	20400	0955-0167
U2	1026-0123	1	1	IC 7912 V RGLTR TO-3 EXCEPT OPT. 009, 010	04713	MC7912CK
U3	1026-0117	3	1	IC 7912 V RGLTR TO-3 EXCEPT OPT. 009, 010	07263	7912KC
U4	1026-0101	1	1	IC V RGLTR TO-3	27014	LM323K
U5	1026-0539	7	1	IC 340 V RGLTR TO-3	27014	LM340K-24
U6	1026-0523	5	1	IC 337 V RGLTR TO-3	27014	LM337K
U7	1026-0423	4	1	IC V RGLTR TO-3	27014	LM317K
W1	00672-60173	8	1	CABLE ASSEMBLY-FP-ALC EXCEPT OPT. 009, 010	20400	00672-60173
W2	00672-60171	6	1	CABLE ASSEMBLY-FP-MOD EXCEPT OPT. 009, 010	20400	00672-60171
W3	00672-60159	0	1	CABLE ASSEMBLY-FRONT PANEL	20400	00672-60159

See introduction to this section for ordering information
*Indicates factory selected value

Table 6-3. Replaceable Parts

Reference Designation	HP Part Number	C D	Qty	Description	Mfr Code	Mfr Part Number
W4	08672-60158	9	1	CABLE ASSEMBLY-REAR PANEL	28480	08672-60158
W5	08672-60182	9	1	CABLE-14 CONDUCTOR	28480	08672-60182
W6	08672-60162	5	1	CABLE ASSEMBLY-26 CONDUCTOR	28480	08672-60162
W7	08672-60170	5	1	CABLE ASSEMBLY-REGULATOR-IC	28480	08672-60170
W8	08672-60174	9	1	CABLE ASSEMBLY-REGULATOR SWITCH	28480	08672-60174
W9	08672-60172	7	1	CABLE ASSEMBLY-REGULATOR-ALC	28480	08672-60172
W10	08672-20156	3	1	CABLE ASSEMBLY-FP TO PMS EXCEPT OPT. 009, 010	28480	08672-20156
W11	08672-20160	9	1	CABLE ASSEMBLY-MOD IN EXCEPT OPT. 009, 010	28480	08672-20160
W12	1250-1741	0		ADAPTER-COAX RTANG M-SMA F-SMA	28480	1250-1741
W13	1250-1741	0		ADAPTER-COAX RTANG M-SMA F-SMA	28480	1250-1741
W14	08672-20161	0	1	CABLE ASSEMBLY-MOD OUT EXCEPT OPT. 009, 010	28480	08672-20161
W15	08672-20157	4	1	CABLE ASSEMBLY-PMS TO CS EXCEPT OPT. 009, 010	28480	08672-20157
W16	08672-20150	5	1	CABLE ASSEMBLY-CS TO ISOLATOR	28480	08672-20150
W17	08672-60161	4	1	CABLE ASSEMBLY-BIAS TEE EXCEPT OPT. 009, 010	28480	08672-60161
W18	08672-60155	6	1	CABLE ASSEMBLY-MODULATOR EXCEPT OPT. 009, 010	28480	08672-60155
W19	08672-60153	4	1	CABLE ASSEMBLY-PHASE LOCK	28480	08672-60153
W20	08672-20150	7	1	CABLE ASSEMBLY-L.O. TO ISOLATOR	28480	08672-20150
W21	1250-1397	2	1	ADAPTER-COAX RTANG M-SMA M-SMA EXCEPT OPT. 009, 010	28480	1250-1397
W22	08672-60185	2	1	CABLE-LB BIAS TEE EXCEPT OPT. 009, 010	28480	08672-60185
W23	08672-60186	3	1	CABLE-LB MODULATOR EXCEPT OPT. 009, 010	28480	08672-60186
W24	08672-20170	1	1	CABLE-MOD/MOD EXCEPT OPT. 009, 010	28480	08672-20170
W25	08672-60157	0	1	CABLE ASSEMBLY-ALC OUT	28480	08672-60157
W26	08672-20162	1	1	CABLE ASSEMBLY-MOD LPF	28480	08672-20162
W27	08672-20151	0	1	CABLE ASSEMBLY-MIXER/AMPLIFIER	28480	08672-20151
W28	08672-20187	0	1	CABLE ASSEMBLY-AMPLIFIER/LPF ONL	28480	08672-20187
W29	08672-20153	0	1	CABLE ASSEMBLY-COUPLER/CS	28480	08672-20153
W30	08672-60156	7	1	CABLE ASSEMBLY-DETR OUT	28480	08672-60156
W31	08672-20154	1	1	CABLE ASSEMBLY-CS/ATTENUATOR EXCEPT OPT. 001, 005, 010	28480	08672-20154
W32	08672-20159	6	1	CABLE ASSEMBLY-ATTEN-OUT EXCEPT OPT. 004, 005, 009, 010	28480	08672-20159
W32	08672-20188	1	1	CABLE ASSEMBLY-ATTEN-OUT OPT.004	28480	08672-20188
W32	08672-20189	2	1	CABLE ASSEMBLY-ATTEN-OUT OPT. 005	28480	08672-20189
W32	08672-20191	6	1	CABLE ASSEMBLY-ATTEN-OUT OPT. 010	28480	08672-20191
W33	08672-60141	0	1	CABLE ASSY-LINE (INCL A12 & C6)	28480	08672-60141
W35	08672-20155	2	1	CABLE ASSY-RIGID COAXIAL, RF IN	28480	08672-20155
W36	8120-3728	1	1	CABLE-ATTEN. CONTROL	28480	8120-3728
W37	8120-2682	2	1	CABLE-BNC (100MHZ REF. IN)	28480	8120-2682
W38	108330	2	1	CABLE-HP-ID, 0.5 METRE	28480	108330
W39	08672-60154	5	1	CABLE ASSEMBLY-PULSE IN P/O J3	28480	08672-60154
W101	08672-20190	5	1	ISOLATOR TO MODULATOR OPT. 009,010 ONLY	28480	08672-20190
				MISCELLANEDUS		
	0362-0265	7	2	CONNECTOR-SGL CONT SKT 1.14-MM-RSC-SZ	28480	0362-0265
	0890-0041	6	1	TUBING-MS .11-D/.08-RGVD .016-WALL PVC	00000	ORDER BY DESCRIPTION
	1251-3279	5	1	CONNECTOR 12-PIN F POST TYPE	28480	1251-3279
	1251-3966	7	6	CONTACT-CONN U/W-POST-TYPE FEM CRP	28480	1251-3966
	1251-4283	3	3	CONTACT-CONN U/W-POST-TYPE FEM CRP	28480	1251-4283

See introduction to this section for ordering information
 *Indicates factory selected value

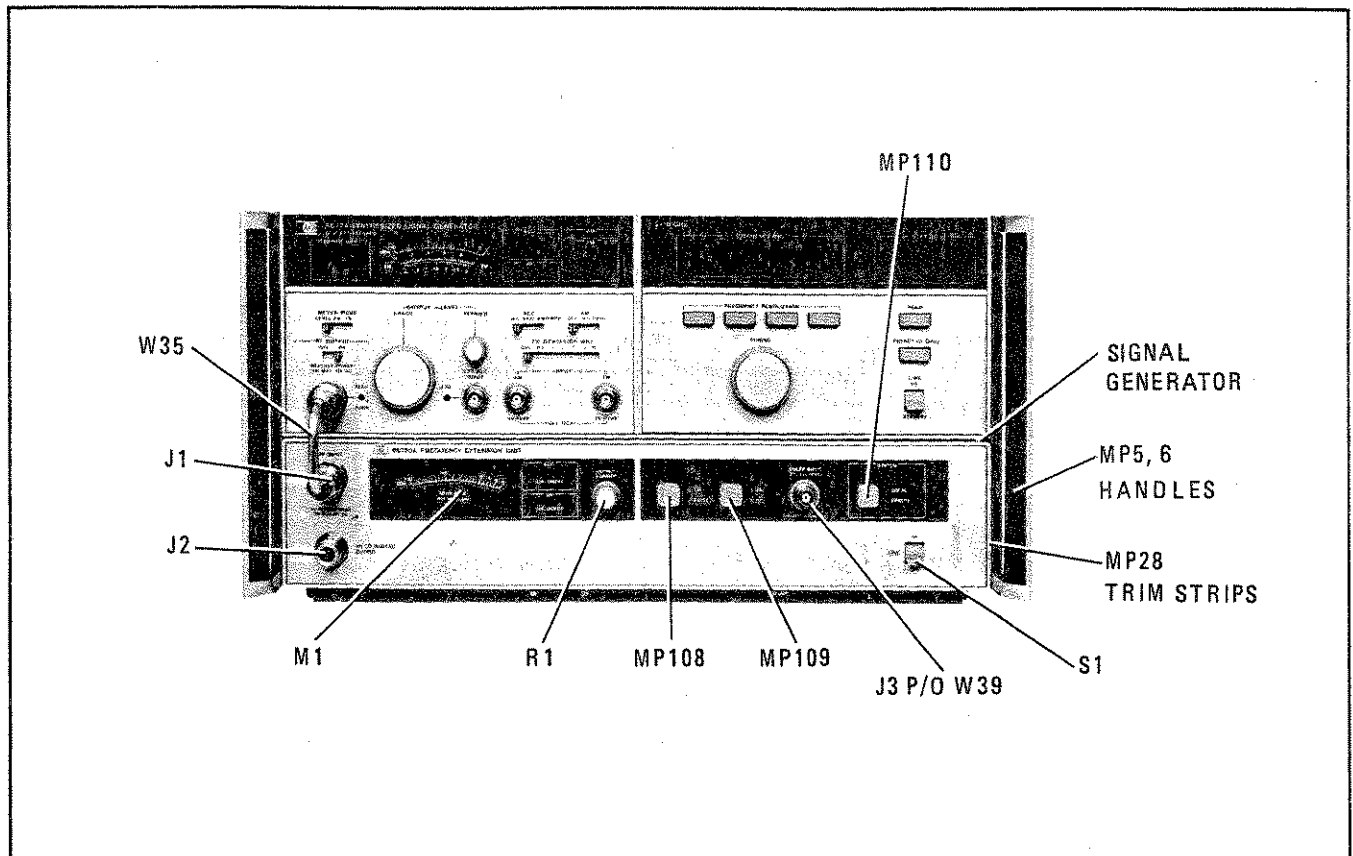

Figure 6-1. FEU Front Panel Chassis and Mechanical Parts Identification

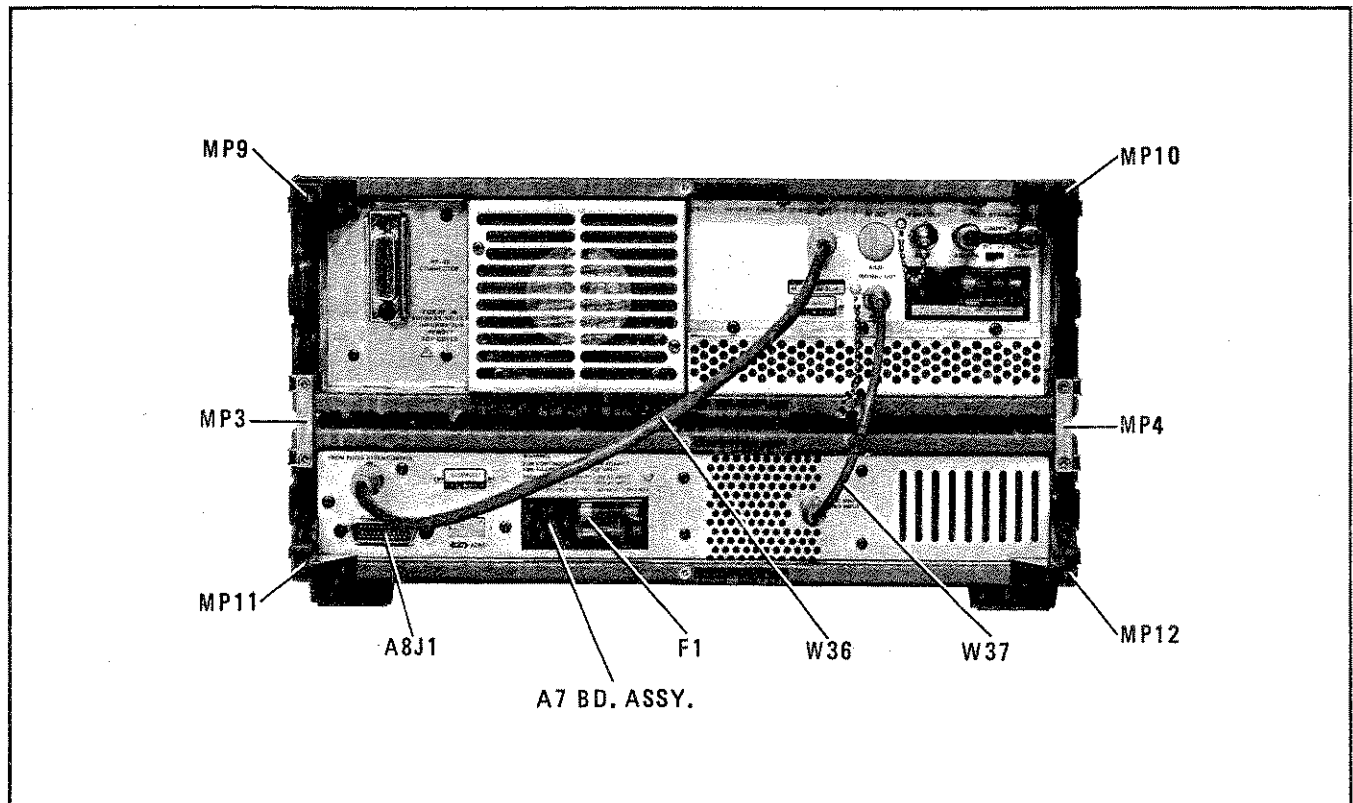

Figure 6-2. FEU Rear Panel Chassis and Mechanical Parts Identification

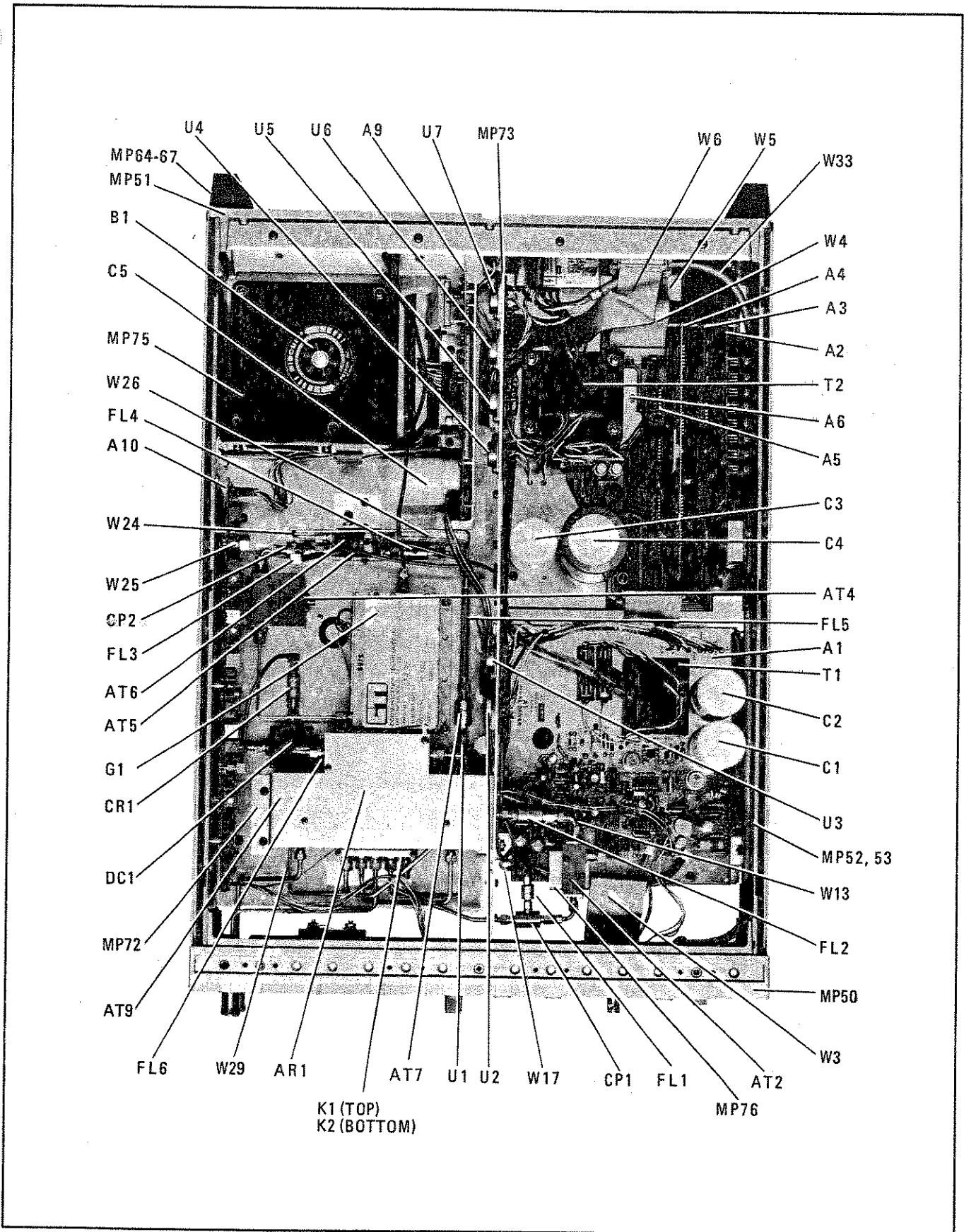

Figure 6-3. FEU Top Chassis Parts, Mechanical Parts and Cable Identification

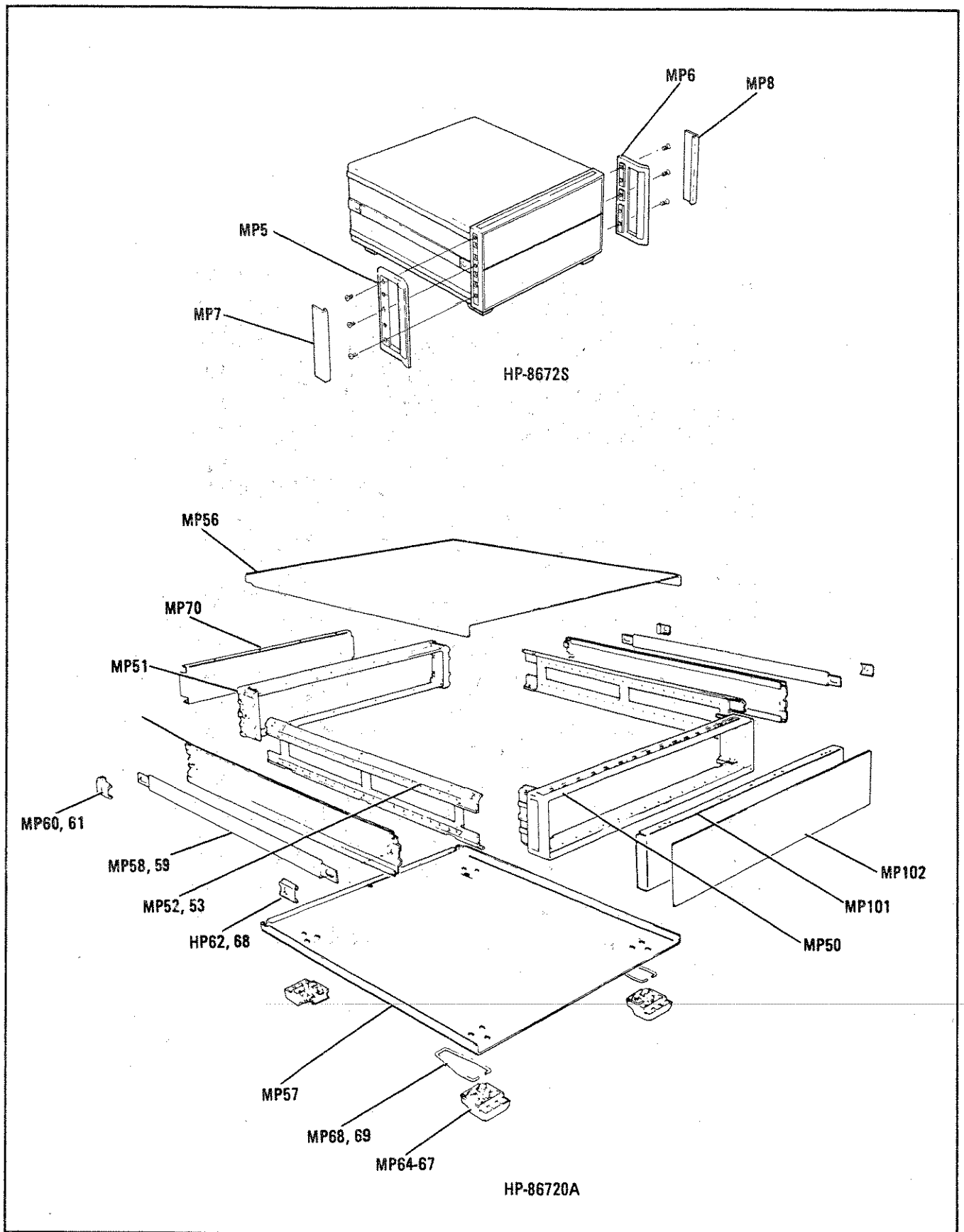

Figure 6-4. Cabinet Parts

Table 6-4. Code List of Manufacturers

Mfr Code	Manufacturer Name	Address	Zip Code
00000	ANY SATISFACTORY SUPPLIER		
00053	SANGAMO ELEC CO S CAROLINA DIV	PICKENS SC	29671
01121	ALLEN-BRADLEY CO	MILWAUKEE WI	53204
01295	TEXAS INSTR INC SEMICOND CMPNT DIV	DALLAS TX	75222
02111	SPECTROL ELECTRONICS CORP	CITY OF IND CA	91745
03500	GE CO SEMICONDUCTOR PROD DEPT	AUBURN NY	13201
05000	K D I PYROFILM CORP	WHIPPANY NJ	07701
04713	MOTOROLA SEMICONDUCTOR PRODUCTS	PHOENIX AZ	85008
06915	RICHCO PLASTIC CO	CHICAGO IL	60646
07263	FAIRCHILD SEMICONDUCTOR DIV	MOUNTAIN VIEW CA	94042
17656	SILICONIX INC	SANTA CLARA CA	95054
19701	MEPCO/ELECTRA CORP	MINERAL WELLS TX	76067
20932	EMCON DIV ITW	SAN DIEGO CA	92129
20940	MICRO-QHM CORP	EL MONTE CA	91731
24046	TRANSITRON ELECTRONIC CORP	WAKEFIELD MA	01880
24546	CORNING GLASS WORKS (BRADFORD)	BRADFORD PA	16701
25000	SIEMENS CORP	ISELIN NJ	08830
27014	NATIONAL SEMICONDUCTOR CORP	SANTA CLARA CA	95051
27167	CORNING GLASS WORKS (WILMINGTON)	WILMINGTON NC	28401
28480	HEWLETT-PACKARD CO CORPORATE HQ	PALO ALTO CA	94304
31585	RCA CORP SOLID STATE DIV	SOMERVILLE NJ	
32997	BURNS INC TRIMPOT PROD DIV	RIVERSIDE CA	92507
56209	SPRAGUE ELECTRIC CO	NORTH ADAMS MA	01247
72136	ELECTRO MOTIVE CORP	FLORENCE SC	06226
73150	BECKMAN INSTRUMENTS INC HELIPOT DIV	FULLERTON CA	92634
75915	LITTELFUSE INC	DES PLAINES IL	60016
77963	ZIERICK MFG CO	MT KISCO NY	10549
86928	SEASTROM MFG CO	GLENDALE CA	91201

SECTION VII MANUAL CHANGES

7-1. INTRODUCTION

This section normally contains information for adapting this manual to instruments for which the content does not apply directly. Since this manual does apply directly to instruments having

serial numbers listed on the title page, no change information is given here. Refer to INSTRUMENTS COVERED BY MANUAL in Section I for additional important information about serial number coverage.

SECTION VIII SERVICE

8-1. INTRODUCTION

This section contains information for troubleshooting and repairing the Signal Generator System. Included are block and circuit diagrams, troubleshooting tests, component locators, and principles of operation.

8-2. SERVICE SHEETS

The foldout pages in this section are service sheets and consist of block diagrams and circuit diagrams.

Table 8-1 Schematic Diagram Notes provides general information which relate to block and schematic diagram symbols.

8-3. Block Diagrams

Service Sheet 1 is the Analog and Pulse Circuits block diagram. Service Sheet 2 is a block diagram of the HP-IB and Front Panel Circuits.

8-4. Circuit Diagrams

Circuit diagrams and their associated information for individual assemblies are contained in Service Sheets 3 through 14. Service Sheet 4 shows the RF Circuits with the pulse modulator circuits removed (Option 009 or 010).

These diagrams are aids for understanding operation and for troubleshooting the Signal Generator System.

8-5. SAFETY CONSIDERATIONS

8-6. Before Applying Power

Verify that the instruments are set to match the available line voltage and that the correct fuses are installed. An uninterrupted safety earth ground must be provided from the main power source to the instruments input wiring terminals, power cords, or supplied power cord sets.

8-7. Warnings and Cautions

Pay attention to WARNINGS and CAUTIONS. They must be followed for your protection and to avoid damage to the equipment.

WARNINGS

Maintenance described herein is performed with power supplied to the instruments and with the protective covers removed. Such maintenance should be performed only by service-trained personnel who are aware of the hazards involved (for example, fire and electrical shock). Where maintenance can be performed without power supplied, the power should be removed.

Any interruption of the protective (grounding) conductor (inside or outside the instrument) or disconnection of the protective earth terminal will create a potential shock hazard that could result in personal injury. Grounding one conductor of a two conductor outlet is not sufficient. Whenever it is likely that the protection has been impaired, the instruments must be made inoperative (i.e., secured against unintended operation).

If these instruments are to be energized via an autotransformer, make sure that the autotransformer's common terminal is connected to neutral (grounded side of mains supply).

Capacitors inside the instruments can still be charged even if the instrument is disconnected from its source of supply.

Make sure that only 250 volt fuses with the required rated current and of the specified type (normal blow, time delay, etc.) are used for replacement. Do not use repaired fuses or short-circuited fuseholders. To do so could create a shock or fire hazard.

CAUTION

Do not disconnect or remove any boards in the Signal Generator System unless the instrument is unplugged. Some boards contain devices which can be damaged if the board is removed when the power is on. Use conductive foam when removing MOS devices from sockets.

Table 8-1. Schematic Diagram Notes (1 of 8)

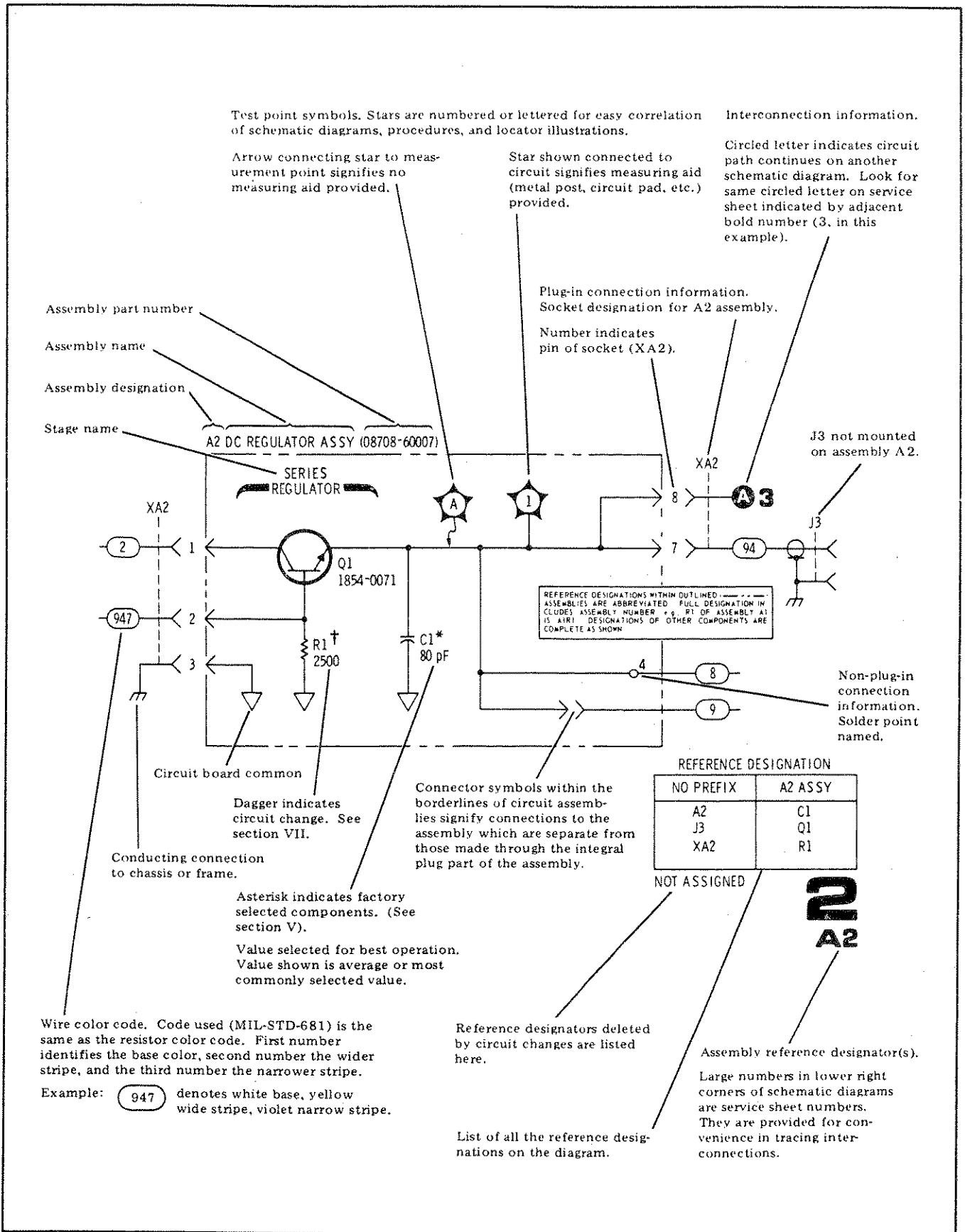

Table 8-1. Schematic Diagram Notes (2 of 8)















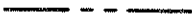

SCHEMATIC DIAGRAM NOTES	
*	Asterisk denotes a factory-selected value. Value shown is typical.
†	Dagger indicates circuit change. See Section VII.
	Tool-aided adjustment.
	Manual control.
	Encloses front-panel designation.
	Encloses rear-panel designation.
	Circuit assembly borderline.
	Other assembly borderline.
	Heavy line with arrows indicates path and direction of main signal.
	Heavy dashed line with arrows indicates path and direction of main feedback.
	Indicates stripline (i.e., RF transmission line above ground).
	Wiper moves toward cw with clockwise rotation of control (as viewed from shaft or knob).
	Numbered Test Point measurement aid provided.
	Encloses wire or cable color code. Code used is the same as the resistor color code. First number identifies the base color, second number identifies the wider stripe, and the third number identifies the narrower stripe, e.g., denotes white base, yellow wide stripe, violet narrow stripe.
	A direct conducting connection to earth, or a conducting connection to a structure that has a similar function (e.g., the frame of an air, sea, or land vehicle).
	A conducting connection to a chassis or frame.
	Common connections. All like-designation points are connected.
	Letters = off-page connection, e.g., AK3 Number = Service Sheet number for off-page connection, e.g., 12
	Number (only) = on-page connection.

Table 8-1. Schematic Diagram Notes (3 of 8)

SCHEMATIC DIAGRAM NOTES



Indicates multiple paths represented by only one line. Letters or names identify individual paths. Numbers indicate number of paths represented by the line.

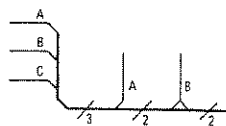

Coaxial or shielded cable.

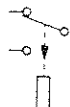

Relay. Contact moves in direction of arrow when energized.



Indicates a pushbutton switch with a momentary (ON) position.



Indicates a PIN diode.



Indicates a current regulation diode.



Indicates a voltage regulation diode.



Indicates a Schottky (hot-carrier) diode.

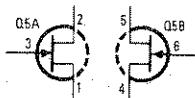

Multiple transistors in a single package—physical location of the pins is shown in package outline on schematic.



Identification of logic families as shown (in this case, ECL).

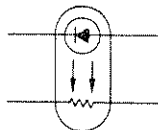

Indicates an opto-isolator of a LED and a photoresistor packaged together. The resistance of the photoresistor is a function of the current flowing through the LED.

Table 8-1. Schematic Diagram Notes (4 of 8)

DIGITAL SYMBOLOGY REFERENCE INFORMATION

Input and Output Indicators

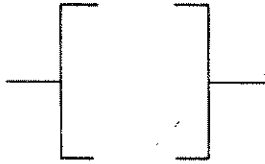

Implied Indicator—Absence of polarity indicator (see below) implies that the active state is a relative high voltage level. Absence of negation indicator (see below) implies that the active state is a relative high voltage level at the input or output.

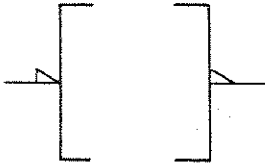

Polarity Indicator—The active state is a relatively low voltage level.

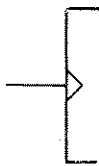

Dynamic Indicator—The active state is a transition from a relative low to a relative high voltage level.



Inhibit Input—Input that, when active, inhibits (blocks) the active state outputs of a digital device.



Analog Input—Input that is a continuous signal function (e.g., a sine wave).

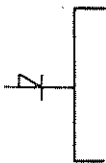

Polarity Indicator used with Inhibit Indicator—Indicates that the relatively low level signal inhibits (blocks) the active state outputs of a digital device.

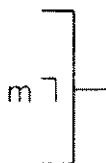

Output Delay—Binary output changes state only after the referenced input (m) returns to its inactive state (m should be replaced by appropriate dependency or function symbols).

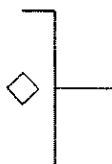

Open Collector Output—Output that must form part of a distributed connection.

Table 8-1. Schematic Diagram Notes (5 of 8)



DIGITAL SYMBOLOGY REFERENCE INFORMATION	
Input and Output Indicators (Cont'd)	
3-STATE	Three-state Output—Indicates outputs that can have a high impedance (disconnect) state in addition to the normal binary logic states.
Combinational Logic Symbols and Functions	
&	AND—All inputs must be active for the output to be active.
≥ 1	OR—One or more inputs being active will cause the output to be active.
$\geq m$	Logic Threshold— m or more inputs being active will cause the output to be active (replace m with a number).
=1	EXCLUSIVE OR—Output will be active when one (and only one) input is active.
=m	m and only m —Output will be active when m (and only m) inputs are active (replace m with a number).
=	Logic Identity—Output will be active only when all or none of the inputs are active (i.e., when all inputs are identical, output will be active).
	Amplifier—The output will be active only when the input is active (can be used with polarity or logic indicator at input or output to signify inversion).
X/Y	Signal Level Converter—Input level(s) are different than output level(s).
	Bilateral Switch—Binary controlled switch which acts as an on/off switch to analog or binary signals flowing in both directions. Dependency notation should be used to indicate affecting/affected inputs and outputs. Note: amplifier symbol (with dependency notation) should be read to indicate unilateral switching.
X→Y	Coder—Input code (X) is converted to output code (Y) per weighted values or a table.
(Functional Labels)	The following labels are to be used as necessary to ensure rapid identification of device function.
MUX	Multiplexer—The output is dependent only on the selected input.
DEMUX	Demultiplexer—Only the selected output is a function of the input.
CPU	Central Processing Unit
PIO	Peripheral Input/Output
SMI	Static Memory Interface

Table 8-1. Schematic Diagram Notes (6 of 8)

DIGITAL SYMBOLOGY REFERENCE INFORMATION

Sequential Logic Functions

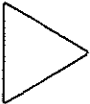
1 

Monostable—Single shot multivibrator. Output becomes active when the input becomes active. Output remains active (even if the input becomes inactive) for a period of time that is characteristic of the device and/or circuit.

G 

Oscillator—The output is a uniform repetitive signal which alternates between the high and low state values. If an input is shown, then the output will be active if and only if the input is in the active state.

FF

Flip-Flop—Binary element with two stable states, set and reset. When the flip-flop is set, its outputs will be in their active states. When the flip-flop is reset, its outputs will be in their inactive states.

T

Toggle Input—When active, causes the flip-flop to change states.

S

Set Input—When active, causes the flip-flop to set.

R

Reset Input—When active, causes the flip-flop to reset.

J

J Input—Analogous to set input.

K

K Input—Analogous to reset input.

D

Data Input—Always enabled by another input (generally a C input—see Dependency Notation). When the D input is dependency-enabled, a high level at D will set the flip-flop; a low level will reset the flip-flop. Note: strictly speaking, D inputs have no active or inactive states—they are just enabled or disabled.

m

Count-Up Input—When active, increments the contents (count) of a counter by “m” counts (m is replaced with a number).

-m

Count-Down Input—When active, decrements the contents (count) of a counter by “m” counts (m is replaced with a number).

→ m

Shift Right (Down) Input—When active, causes the contents of a shift register to shift to the right or down “m” places (m is replaced with a number).

← m

Shift Left (Up) Input—When active, causes the contents of a shift register to shift to the left or up “m” places (m is replaced with a number).

NOTE

For the four functions shown above, if m is one, it is omitted.

(Functional
Labels)

The following functional labels are to be used as necessary in symbol build-ups to ensure rapid identification of device function.

Table 8-1. Schematic Diagram Notes (7 of 8)

DIGITAL SYMBOLOGY REFERENCE INFORMATION**Sequential Logic Functions (Cont'd)**

mCNTR	Counter—Array of flip-flops connected to form a counter with modulus m (m is replaced with a number that indicates the number of states: 5 CNTR, 10 CNTR, etc.).
REG	Register—Array of unconnected flip-flops that form a simple register or latch.
SREG	Shift Register—Array of flip-flops that form a register with internal connections that permit shifting the contents from flip-flop to flip-flop.
ROM	Read Only Memory—Addressable memory with read-out capability only.
RAM	Random Access Memory—Addressable memory with read-in and read-out capability.

Dependency Notation

mAm	Address Dependency—Binary affecting inputs of affected outputs. The m prefix is replaced with a number that differentiates between several address inputs, indicates dependency, or indicates demultiplexing and multiplexing of address inputs and outputs. The m suffix indicates the number of cells that can be addressed.
Gm	Gate (AND) Dependency—Binary affecting input with an AND relationship to those inputs or outputs labeled with the same identifier. The m is replaced with a number or letter (the identifier).
Cm	Control Dependency—Binary affecting input used where more than a simple AND relationship exists between the C input and the affected inputs and outputs (used only with D-type flip-flops).
Vm	OR Dependency—Binary affecting input with an OR relationship to those inputs or outputs labeled with the same identifier. The m is replaced with a number or the letter (the identifier).
Fm	Free Dependency—Binary affecting input acting as a connect switch when active and a disconnect when inactive. Used to control the 3-state behavior of a 3-state device.

NOTE

The identifier (m) is omitted if it is one—that is, when there is only one dependency relationship of that kind in a particular device. When this is done, the dependency indicator itself (G , C , F , or V) is used to prefix or suffix the affected (dependent) input or output.

Table 8-1. Schematic Diagram Notes (8 of 8)

DIGITAL SYMBOLOGY REFERENCE INFORMATION**Miscellaneous**

	Schmitt Trigger—Input characterized by hysteresis; one threshold for positive going signals and a second threshold for negative going signals.
Active	Active State—A binary physical or logical state that corresponds to the true state of an input, an output, or a function. The opposite of the inactive state.
Enable	Enabled Condition—A logical state that occurs when dependency conditions are satisfied. Although not explicitly stated in the definitions listed above, functions are assumed to be enabled when their behavior is described. A convenient way to think of it is as follows: A function becomes active when: <ul style="list-style-type: none">• it is enabled (dependency conditions—if any—are satisfied)• and its external stimuli (e.g., voltage level) enters the active state.

8-8. RECOMMENDED TEST EQUIPMENT AND ACCESSORIES

Test equipment and test accessories required to maintain the Signal Generator System are listed in Table 1-4, Recommended Test Equipment in this manual, and in the Recommended Test Equipment Table in the HP 8672A Operating Manual. Other equipment may be substituted if the listed critical specifications are met.

8-9. SERVICE TOOLS, AIDS AND INFORMATION

8-10. Support Kit

The 11712A Support Kit is available to aid the user in maintaining and servicing the Signal Generator System. It consists of cables, adaptors, terminations, prerecorded programs, extender boards, and two diagnostic extender boards.

8-11. Parts and Cable Locations

The locations of individual components mounted on printed circuit boards or other assemblies are shown adjacent to the schematic diagram on the appropriate Service Sheet. The part reference designator is the assembly designator plus the part designator. For example, A6R9 is R9 on the A6 assembly. For specific component descriptions and ordering information, refer to Table 6-3, Replaceable Parts, in Section VI. Chassis and frame parts, as well as mechanical parts and cables, are identified.

8-12. Pozidriv Screwdrivers

Many screws in the instrument appear to be Philips, but are not. To avoid damage to the screw slots, Pozidriv screwdrivers should be used. HP 8710-0899 is a No. 1 Pozidriv; HP 8710-0900 is a No. 2 Pozidriv.

8-13. Blade Tuning Tools

For adjustments requiring a non-metallic tuning tool, use the J.F.D. Model No. 5284 (HP 8710-1010). In situations not requiring non-metallic tuning tools, an ordinary small screwdriver or other suitable tool is sufficient. A metal adjustment tool is provided in the 11726A Support Kit. No matter what tool is used, never try to force any adjustment control in this instrument.

8-14. Servicing Aids on Printed Circuits

The servicing aids include test points, transistor and integrated circuit designations, adjustment

callouts, and assembly part numbers. Refer to Table 8-2 for a list of etched circuit soldering equipment.

8-15. Non-Field Repairable Assemblies

A few of the Signal Generator System's assemblies must be replaced if they malfunction. The following FEU assemblies are not field repairable:

- AR1 40 dB Amplifier
- AT1 Termination
- AT2 High Band Pulse Modulator
- AT3 Termination
- AT4 Isolator
- AT5 Low Band Pulse Modulator
- AT6 ALC Modulator
- AT7 10 dB Attenuator
- AT8 Termination
- AT9 110 dB Attenuator Assembly
- B1 Blower Assembly
- CP1 Bias Tee Assembly
- CP1 Bias Tee Assembly
- DC1 20 dB Directional Coupler
- FL1 Low Pass Filter Assembly
- FL2 High Pass Filter Assembly
- FL3 Low Pass Filter Assembly
- FL4 High Pass Filter Assembly
- FL5 4.5 GHz Filter Assembly
- FL6 2.0 GHz Filter Assembly
- G1 4.2 GHz Oscillator Assembly
- K1 CW/Pulse Relay
- K2 Low/High Band Relay

Refer to Section VIII of the HP 8672A Operating and Service Manual for additional information on non-field repairable assemblies in the Signal Generator.

8-16. After Service Product Safety Checks

Visually inspect interior of instrument for any signs of abnormal internally generated heat, such as discolored printed circuit boards or components, damaged insulation, or evidence of arcing. Determine and remedy the cause of any such condition.

Using a suitable ohmmeter, check resistance from instrument enclosure to ground pin on power cable plug. The reading must be less than one-half ohm. Flex the power cable while making this measurement to determine whether intermittent discontinuities exist.

Check any front or rear panel terminals marked as ground, using the procedure in the paragraph above.

Table 8-2. Etched Circuit Soldering Equipment

Item	Use	Specification	Item Recommended	HP Part No.
Soldering Tool	Soldering, Heat Staking	Wattage: 35W Tip Temp.: 390°—440°C (735°—825°F)	Ungar No. 135 Ungar Division Eldon Ind. Corp. Compton, CA 90220	8690-0167
Soldering Tip	Soldering, Unsoldering	*Shape: Chisel	*Ungar PL113	8690-0007
Soldering Tip	Heat Staking	Shape: Cupped	HP 5020-8160 or modified Ungar PL111	5020-8160
De-Soldering Aid	To remove molten solder from connection	Suction Device	Soldapullt by Edsyn Co., Van Nuys, CA 91406	8690-0060
Rosin (flux) Solvent	To remove excess flux from soldered area before application of protective coating	Must not dissolve etched circuit base board.	Freon	8500-0232
Solder	Component replacement; Circuit Board repair wiring	Rosin (flux) core, high tin content (63/37 tin/lead), 18 gauge (SWG) 0.048 in. diameter preferred.		8090-0607
*For working on circuit boards, for general purpose work, use No. 555 Handle (8690-0261) and No. 4037 Heating Unit 47½ — 56½ W (HP 8690-0006); tip temperature of 850° — 900°F; and Ungar No. PL113 ⅜" chisel tip.				

After Service Product Safety Checks (cont'd)

Check resistance from instrument enclosure to the line and neutral (tied together) with the power switch on and the power source disconnected. The minimum acceptable resistance is two megohms.

Check line fuses to verify that a correctly rated fuse is installed (refer to Section II).

8-17. TROUBLESHOOTING

8-18. General

Instrument problems usually occur in three general categories: operator errors, instrument performance out of specification and catastrophic failures. The troubleshooting strategy is different for each category. For a complete list of specifications refer to Table 1-1, Specifications, in Section I.

Operator Errors. Apparent failures sometimes result from operator errors. For example, attempting to adjust the FEU OUTPUT VERNIER when the system is in the pulse modulation mode of operation.

Instrument Performance Out of Specification. Three levels of testing can be performed to verify that the instrument is operating normally and within specification. The first level of testing is to perform the Operator's Checks in Section III of this manual and the HP 8672A Operating and Service Manual. These checks involve the least amount of time and can reveal much about overall operation. The second and third levels of testing are done by performing the Abbreviated Performance Tests (for 90% confidence) or the full Performance Tests. Both of these tests are located in Section IV.

Troubleshooting (cont'd)

The specifications are listed in Table 1-1. If a specification is only slightly out of limits, it can sometimes be brought into specification by an adjustment. The procedures for all adjustments are in Section V. References listed for each adjustment indicate which service sheet to consult when the adjustment fails. In general, it is also good practice to perform the troubleshooting checks for Service Sheet 1 since they take only a few minutes and reveal much about the instrument.

Catastrophic Failures. Begin troubleshooting of catastrophic failures by determining which of the two instruments has failed (refer to Service Sheet 1 in this manual). If the FEU has failed, additional troubleshooting information is contained in the Service Sheets in this manual. If the Signal Generator has failed, refer to the HP8672A Operating and Service Manual.

SERVICE SHEET 1 - ANALOG AND PULSE MODULATION CIRCUITS

GENERAL

The HP 8672S Signal Generator System consists of an HP 8672A Signal Generator and an HP 86720A Frequency Extension Unit. Theory of operation and troubleshooting for the Signal Generator are covered in the HP 8672A Operating and Service Manual. Theory of operation and troubleshooting for the FEU are covered in this section.

Figure 1-3 shows the relationship between the Signal Generator and the FEU. This service sheet covers the Analog and Pulse Modulation circuits of the FEU. Service Sheet 2 covers the HP-IB and front panel circuits. In addition, the troubleshooting information required to determine which of the two instruments is not operating correctly is included in this service sheet.

PRINCIPLES OF OPERATION

Signal Generator System

The Signal Generator System uses a heterodyne technique in the FEU to extend the standard 2 to 18 GHz range of the Signal Generator to a lower limit of 10 MHz. This technique allows the system to retain all of the capabilities of the Signal Generator while adding the additional frequency range and pulse modulation capabilities of the FEU. Refer to Table 1-1 for a list of the Signal Generator System specifications as related to the standard Signal Generator specifications.

The Signal Generator used in the system must contain either Option 034 or 038. The major differences between a standard Signal Generator and either an Option 034 or 038 Signal Generator are as follows:

- a. The 110 dB step attenuator is removed.
- b. The circuits necessary to control a similar attenuator in the FEU have been added (Option 034). Or, a two-position OUTPUT LEVEL RANGE switch is installed to control an FEU that does not contain this attenuator (Option 038).
- c. During low band operation, the Signal Generator FREQUENCY MHz display indicates the 10 MHz to 2 GHz output frequency.
- d. Also, during low band operation, the RF output from the Signal Generator to the FEU is

from 4.1 to 6.2 GHz. This signal is heterodyned with the 4.2 GHz oscillator in the FEU to provide the 10 MHz to 2 GHz RF output from the FEU.

- e. The circuits necessary to provide the down convert and the +10 dB control signals have been added.

Refer to the option description paragraphs in Section I for additional information on the various option configurations available with the Signal Generator System.

Frequency Extension Unit

The FEU is functionally divided into five major sections. The following four are shown on this service sheet:

1. Two RF paths. A low band of 10 MHz to 1.999 999 GHz and a high band of 2 to 18 GHz.
2. The Automatic Leveling Control (ALC) circuits (A10). The ALC in the FEU is only active during low band operation.
3. The pulse modulation circuits (A1).
4. The three power supply circuits (A1, A9, and A6).

The fifth section is the HP-IB and front panel circuits that are covered in Service Sheet 2.

RF Paths

The RF signal from the Signal Generator is applied to the RF INPUT connector of the FEU. If the high band path (without pulse modulation) is selected, the signal passes through the CW/pulse relay and the high band/low band relay and is applied to the 110 dB step attenuator.

This attenuator is controlled by the Signal Generator signals applied to the FROM 8672A ATTEN CONTROL connector. The specific signal corresponds to the value displayed by the RANGE dBm LEDs on the Signal Generator front panel. Note that the Signal Generator does not contain an internal step attenuator. Therefore, all of the 10 dB steps of attenuation for the system are inserted by the step attenuator in the FEU.

In the high band, the RF output level over a range of +3 to -10 dB (labeled dBm) is adjusted by the Signal Generator OUTPUT LEVEL VERNIER

SERVICE SHEET 1 (cont'd)

control. This level is indicated on the Signal Generator meter relative to the RANGE dBm level displayed.

If pulse modulation is selected in the high band, the RF signal is applied through the CW/Pulse relay to the bias tee and high band pulse modulator. How the pulse modulation is performed is covered later. The pulse output is then routed back to the high band path. Note that there is no ALC for the high band pulse output. Therefore, this output is uncalibrated.

When the Signal Generator is tuned below 2 GHz, the system switches to low band operation. Note that the Signal Generator must sense the logic signal Nhet (ground) in the FEU to enable it to switch to low band. The Het On control signal is then applied to the FEU and the high/low band relay is activated. In the HP 8672A Operating and Service Manual the Nhet and Het On logic signals are shown on Service Sheet 7-A2.

With the low band path selected, the appropriate 4.21 to 6.2 GHz signal from the Signal Generator is routed to the mixer in the FEU. This signal is mixed with the 4.2 GHz output from the ϕ locked oscillator to provide the 10 MHz to 2 GHz low band output.

In the low band, the RF output level over a range of +3 to -10 dB is adjusted by the FEU OUTPUT VERNIER control. This level is indicated on the FEU meter relative to the Signal Generator RANGE dBm level displayed. Also, in the low band only, an additional +10 dBm of RF output is obtained when the Signal Generator OUTPUT LEVEL control is set to +10 dBm. A +10 dB control signal from the Signal Generator is applied to the +10 dB control circuit in the ALC loop.

The 4.2 GHz oscillator is phase locked with the Signal Generator by the 100 MHz REF INPUT. Its output is applied through the bias tee and low band modulator to the ALC pin modulator. The ALC input to the pin modulator levels both the CW and the pulse output from +13 to -120 dBm in the 10 MHz to 2 GHz range. The output of the mixer is routed through a 40 dB isolation amplifier and directional coupler to the step attenuator. Anytime the 4.2 GHz oscillator loses phase lock, the RF UNLOCKED LED on the FEU front panel lights.

FEU Automatic Leveling Control Loop (Low Band Operation Only)

The major functional components of the ALC loop are the crystal detector, the integrator, log amplifier, reference amplifier, and the ALC pin modulator. The RF output amplitude from the directional coupler is detected by the crystal detector. The integrator sums the detected output with a reference and outputs a control voltage. The current output from the modulation driver is used to control the level of RF attenuation in the pin modulator. Because of the non-linear characteristics of the crystal detector and the pin modulator and because the pin modulator must be current driven, extra circuits are required in the basic ALC loop. In addition, because the low band pulse output must also be leveled, a digital sample-and-hold is used to store the requested power output level.

The crystal detector's output is linear with respect to the RF output power it represents. The log amplifier converts this relationship to a linear voltage-to-dBm power characteristic. The integrator sums the log amplifier output with the output from the reference amplifier. The integrator output is applied through the CW/pulse control logic to the exponential amplifier and modulation driver.

As long as the ALC loop is operating properly and the RF output is leveled, the sum of the log amplifier output and the reference amplifier output is very close to 0 Vdc. As a result, the output from the high-gain integrator is held at the level necessary to provide the requested RF power output.

The reference amplifier output can be modified by the +10 dB control circuit and the vernier inputs (local or remote). If the Signal Generator OUTPUT LEVEL RANGE switch is set to +10 dBm, the +10 dB control signal is applied to the FROM 8672A ATTEN CONTROL connector. The +10 dB control circuit enables the FEU ALC to level low band signals up to +13 dBm. In local operation, the front panel vernier control is used to modify the reference. In remote operation, this vernier information is decoded by the HP-IB circuits and used to modify the ALC reference.

When using low band pulse modulation, the ALC loop is used to level the peak pulse power. This power is held to ± 1 dB of the CW level at which the system is set when the FEU is switched to pulse modulation.

SERVICE SHEET 1 (cont'd)

This leveling is accomplished by digitally sampling and holding the output of the integrator.

When the FEU is switched to pulse modulation, the Analog-to-Digital Converter (ADC) control enables the ADC to accept 80 kHz clock pulses. The analog output of the integrator is converted to its digital equivalent. The output of the ADC is then clocked into Digital-to-Analog Converter (DAC). The ADC control now disables the ADC and the digital sample-and-hold is complete. The analog output of the DAC is the same as the output of the integrator when it was sampled. This value is retained until the FEU is cycled out of and then back into pulse modulation.

The CW/Pulse control logic determines which FET switch is active. During CW operation, the continuously updated analog signal is applied to the exponential amplifier. During pulse operation, the stored analog output from the DAC is used.

The dBm meter and the LVL UNCAL LED are used only in low band CW operation. If the ALC loop is unable to level the RF power, the unlevelled detector lights the LVL UNCAL LED and disconnects the dBm meter. During pulse or high band operation the meter is disconnected and the LVL UNCAL LED is disabled.

Pulse Modulation

The FEU provides pulse modulated output in both bands. However, only the low band pulse output is leveled. In both cases, an external pulse input to the pulse modulator drive circuits is required.

The modulator drive circuits provide the signals necessary to switch the selected pulse modulator circuit on and off. To achieve rapid rise and fall time on the RF output pulses a series/shunt type modulator is used. The pulse on/off logic and driver circuits provide the series drive to the bias tee. The pulse modulation driver circuit provides the shunt drive to the pulse modulator.

There are separate bias tees and pulse modulators for the high and low bands. The drive signals are routed to the selected pulse modulation path by a relay controlled by the low band signal.

Power Supplies

The FEU contains the following three power supplies:

a. The main power supply that supplies +24 Vdc and +5 Vdc throughout the instrument. It is located on the A6 Motherboard Assembly.

b. The pulse driver power supply that supplies +12 Vdc, -12 Vdc and +5.2 Vdc to the pulse driver board. It is located on the A1 Pulse Driver Assembly.

c. The ALC power supply that supplies +20 Vdc and -10 Vdc to the ALC Amplifier Assembly and some of the RF Path circuits. It is located on the A9 ALC Power Supply Assembly.

TROUBLESHOOTING**General****CAUTION**

DO NOT remove or insert any board assembly with the instrument LINE switch turned on. Always turn the switch to OFF prior to removing or inserting a board. There are some components that could be damaged by transients generated when power is on.

If the instrument is operating correctly in the local mode but does not operate correctly during HP-IB operation, begin troubleshooting by performing the procedures on Service Sheet 2.

If the instrument is not operating correctly in the local mode, begin troubleshooting by performing the preliminary check and power on procedure below.

Preliminary Check and Power On Procedure

1. Verify the Signal Generator and the FEU are correctly interconnected. Refer to Section 2.
2. Apply power to the Signal Generator. Refer to Section 3 of the HP 8672A Operating and Service Manual. If power cannot be applied to the Signal Generator, troubleshoot it as directed in the manual.
3. Set the FEU LINE switch to ON. Verify the CW LED lights. If power cannot be correctly applied to the FEU, perform the power on troubleshooting procedure below.

If power can be correctly applied to the system, perform the Signal Generator Operational Verification Test in Section 4.

SERVICE SHEET 1 (cont'd)**Test Equipment**

Frequency Counter	HP 5343A
Power Meter	HP 436A
Power Sensor	HP 8481A
Spectrum Analyzer	HP 8569B
Diode Detector	HP 8472B
Digital Voltmeter	HP 3455A
Pulse Generator	HP 8013B
Oscilloscope	HP 1715A

FEU Power On Troubleshooting

Because the FEU power on troubleshooting requires that the Signal Generator System be disassembled, it should be performed only if power cannot be applied to the FEU or if it is determined that the FEU is faulty. The FEU has three separate power supplies. It is recommended that the outputs of all three be checked in the following order:

NOTE

If any power supply requires adjustment, perform the adjustment procedure for any assembly that uses the power supply outputs.

- a. Main power supply
 - A6TP1 +5 ±0.4 Vdc
 - A6TP2 +24 ±1.4 Vdc
- b. ALC power supply
 - A9TP1 -10 ±0.8 Vdc
 - A9TP2 +20 ±0.7 Vdc
- c. Pulse driver power supply
 - A1TP3 +12 ±0.7 Vdc
 - A1TP7 +5.2 ±0.4 Vdc
 - A1TP14 -12 ±0.7 Vdc
 - A1TP15 -5.2 ±0.4 Vdc

If any of the power supplies are out of tolerance, refer to the applicable Service Sheet and correct the problem before proceeding.

The following troubleshooting information is based on the results of performing the Signal Generator Operational Verification Check in Section 4. It assumes that the system has power applied to it and is ready to operate. When the first malfunction is encountered in the verification, refer to the same check listed below for troubleshooting directions. For example, if the first malfunction indica-

tion occurs in the Power Check, refer to that check in the troubleshooting to determine the subsequent corrective action. It is very important that the applicable check be referenced at the first malfunction indication because the corrective action assumes that all previous indications are correct.

Frequency Check Troubleshooting

1. If there is no output from the Signal Generator System or if the frequency is incorrect, remove the RF Input cable (W35) and check the output from the Signal Generator. One of the following three indications are possible:

- a. No output from the Signal Generator.
- b. Incorrect frequency from the Signal Generator. In low band operation the output should be from 4.21 to 6.2 GHz. In the high band the frequency should be the same as that indicated on the Signal Generator. If the Signal Generator will not tune below 2 GHz, check that the ground input (Nhet) from the FEU (pin 3 of J1, FROM 8672A ATTEN CONTROL) is present and that the cable (W36) has continuity.
- c. The output from the Signal Generator is correct.

If a or b, troubleshoot the Signal Generator (refer to the HP 8672A Operating and Service Manual). If the ground (Nhet) is not present, refer to Service Sheet 9. If c, continue with step 2.

NOTE

Always check the power supply voltages in the FEU before troubleshooting any individual circuit.

2. If the output from the Signal Generator is correct, disassemble the Signal Generator System and use a cable and adapters to connect the RF OUTPUT from the Signal Generator to the FEU.

NOTE

A good method of checking the low band RF path and ALC loop is to set the FEU to 0 dBm in pulse complement mode. In this mode, the RF path can be broken and measurements made without changing the ALC levels.

SERVICE SHEET 1 (cont'd)

3. If there is no output in either band, check the high band RF path through the FEU (refer to Service Sheet 3 or 4). If there is no output or incorrect frequency output in the low band only, continue with step 4.
4. Check the frequency and output of the low band RF path starting at the 4.2 GHz Oscillator (refer to Service Sheet 3 or 4).
5. If the High Band/Low Band Relay (K2) is not activating, check the Het On signal to the FEU (refer to Service Sheet 11). The Het On signal from the Signal Generator is high when in low band operation.

Power Check Troubleshooting

1. If the power output of the Signal Generator System is incorrect, remove the front panel RF Input cable (W34) and check the output of the Signal Generator at 0 dBm in the high band. Note that the power output normally reads 1 or 2 dB higher than the front panel indication. Vary the Signal Generator VERNIER control and verify the power output tracks the control. If the output is incorrect, troubleshoot the Signal Generator.
2. If the output from the Signal Generator is correct, disassemble the Signal Generator System and use a cable and adapters to connect the RF OUTPUT from the Signal Generator to the FEU.
3. If the output is incorrect in both bands, the problem is either the Step Attenuator in the FEU or the control signals from the Signal Generator. Vary the OUTPUT LEVEL control from 0 dBm to -110 dBm and check the input control signals (refer to Service Sheet 3 or 4). If the control signals are incorrect, troubleshoot the Signal Generator. If they are correct, replace the Step Attenuator.
4. If the output is incorrect in the low band only, the problem is in the ALC loop. To make a quick check of the ALC loop for a major failure, vary the OUTPUT VERNIER control on the FEU and check the following test points:

- a. A10TP4 should be approximately 0 Vdc at +3 dBm and -6.2 Vdc at -12 dBm.

- b. A10TP9 should remain at approximately 0 Vdc.

- c. A10TP7 should be approximately +0.25 Vdc at +3 dBm and -0.25 Vdc at -12 dBm. These limits are valid only if A10R109 (MW) is correctly adjusted.

5. The RF path portion of the ALC loop can be checked by putting the FEU into pulse/complement mode to hold the ALC input to the ALC pin modulator level.
6. If no major failure is located, perform the Low Band Adjustment in Section 5 to determine the faulty portion of the ALC circuit.

Pulse Modulation Check Troubleshooting

1. If there are no pulse outputs in either band, the problem is probably in the Pulse Driver Assembly (A1). Refer to Service Sheet 5 for troubleshooting information.
2. If there is a pulse output in only one band, the problem is probably in the bias tee or pulse modulator of the faulty band. This troubleshooting information is also covered on Service Sheet 7. In addition, relays A1K1 and A1K2 on the Pulse Driver Assembly or the Low Band (L) input from Service Sheet 11 can cause this problem. Also, note that the CW/Pulse relay (K1) switches to pulse in high band only. This function is controlled by A2CR43 on the Driver Assembly (Service Sheet 11).
3. If the FEU cannot level the pulse output in low band, the problem is probably in the Digital Sample-and-Hold circuit and related circuits. Refer to Service Sheet 7 for troubleshooting information.

Phase Lock Check Troubleshooting

1. If the RF UNLOCKED annunciator does not light when the 100 MHz REF INPUT cable is removed, either the annunciator or the 4.2 GHz oscillator is faulty.
2. If the RF UNLOCKED annunciator lights during normal operation, the 4.2 GHz oscillator is probably faulty or out of adjustment.

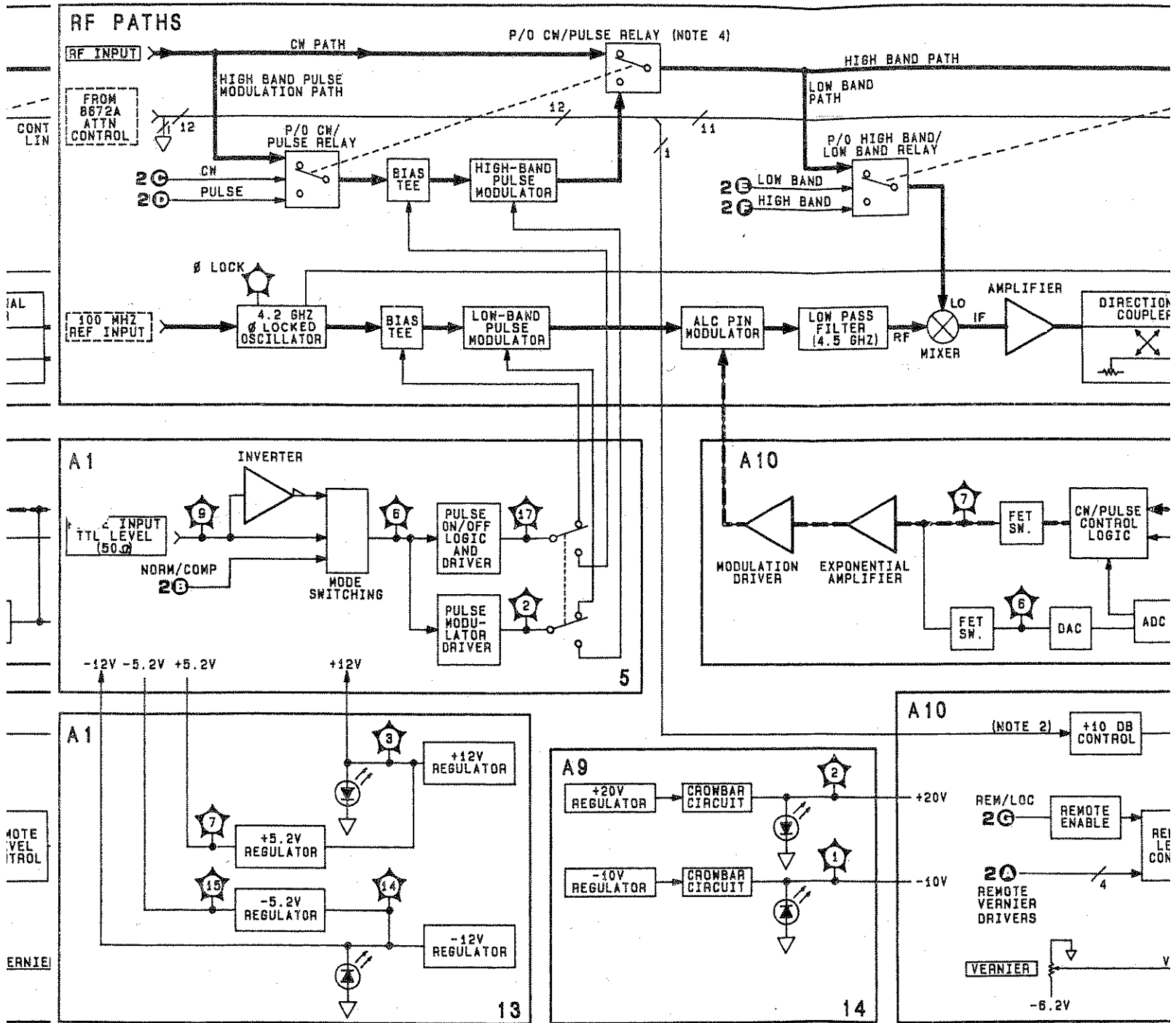

SERVICE SHEET 2 (cont'd)

If the program runs correctly, the FEU is operating correctly in remote. However, it is possible that a problem exists in the Signal Generator. Some of the remote functions that affect the FEU are controlled by the Signal Generator. For example, although the step attenuator is in the FEU, the attenuator setting must be sent to the Signal Generator. Refer to Section 3 of this manual for additional information on programming the Signal Generator System. Refer to the HP 8672A Operating and Service Manual to troubleshoot the Signal Generator HP-IB circuits.

If the program is not running correctly, continue with this procedure. If the front panel meter is the only malfunction in remote operation, skip to step 9.

NOTE

If an incorrect result occurs in any of the following steps, refer to the applicable service sheet and check the inputs to the circuit that failed.

4. Probe A5U4 pins 6 and 9 with the logic probe to verify that the one-shots are working. If they are not, check if the handshake signals shown in Figure 8-2 are present. Stop and restart the program as required to check these signals.
5. Probe A4U2 pin 5 to verify the pulse that triggers the decoders is present.

6. Verify A4U9B pin 9 (Listen flip-flop) is high.
7. Verify A4U4A pin 12 (Remote/Local logic) is high.
8. Verify A5U5 pin 14 (Address Comparator) pulses.

NOTE

The remote level circuits are located on the A10 ALC Amplifier Assembly (Service Sheet 7).

9. Halt the program and send the following command:

OUTPUT 728; "A1234"

10. Verify the inputs to the remote level DAC at A10U15 pins 5, 6, 7, and 8 are high.
11. Send the following command:

OUTPUT 728; "B1234"

12. Verify the inputs at A10U15 pins 5, 6, 7, and 8 are low. If the inputs to the DAC are correct, troubleshoot the remote level circuits on the A10 ALC Amplifier Assembly. If the inputs are incorrect, trace the signal back through the A2 Driver Assembly to determine where the control signal is lost.

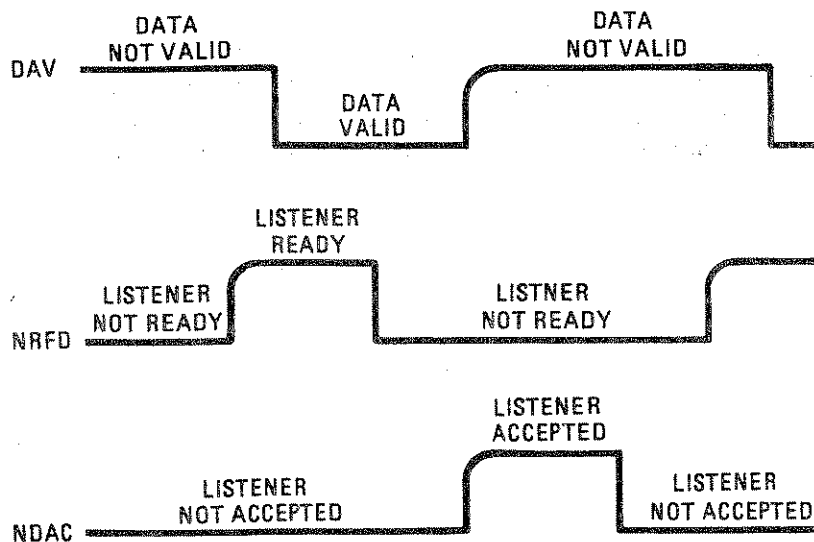

Start with the talker waiting for the listener to release NRFD (not ready for data) indicating it is ready.

When the listener is ready, NRFD goes high (false). The talker then places valid data on DIO1 through DIO8 and sets DAV (data valid) low (true).

NRFD then goes low (true) and the talker waits for the listener to indicate it has accepted the data (or ignored it) by releasing the NDAC (not data accepted) to a high (false, i.e., data is accepted).

The talker sets DAV high (false) and again waits for the listener to release NRFD.

(NOTE that if ATN is true, all instruments on the bus must handshake regardless of whether they are talkers, listeners, or bystanders. Being in remote or local has nothing to do with handshaking.) If ATN is false, they only handshake if addressed.

Figure 8-2. Simplified HP-IB Handshake between a Talker and One Listener.

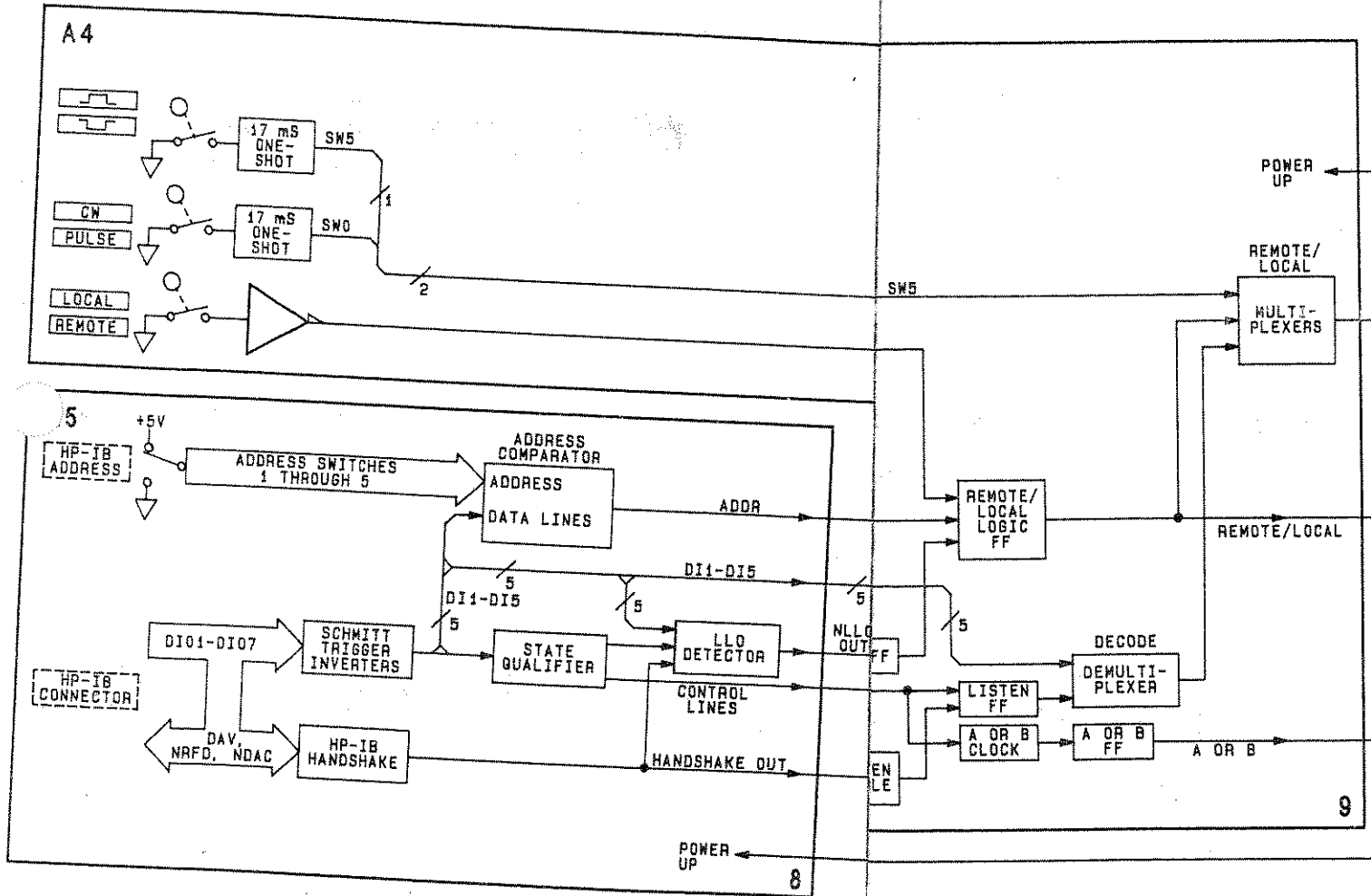

RF RELAYS
11 AP P/O NB

