

User's Guide

HP 81531A Sensor Module

SERIAL NUMBERS

This manual applies to all instruments.



HP Part No. 81531-90011
Printed in Germany

Second Edition
E0796

Notices

This document contains proprietary information that is protected by copyright. All rights are reserved.

No part of this document may be photocopied, reproduced, or translated to another language without the prior written consent of Hewlett-Packard GmbH.

© Copyright 1996 by:
Hewlett-Packard GmbH
Herrenberger Str. 130
71034 Boeblingen
Germany

Subject Matter

The information in this document is subject to change without notice.

Hewlett-Packard makes no warranty of any kind with regard to this printed material, including, but not limited to, the implied warranties of merchantability and fitness for a particular purpose.

Hewlett-Packard shall not be liable for errors contained herein or for incidental or consequential damages in connection with the furnishing, performance, or use of this material.

Printing History

New editions are complete revisions of the guide reflecting alterations in the functionality of the instrument. Updates are occasionally made to the guide between editions. The date on the title page changes when an updated guide is published. To find out the current revision of the guide, or to purchase an updated guide, contact your Hewlett-Packard representative.

Control Serial Number: Edition 2 applies directly to all instruments.

Edition 1 : 1st May 1990 : 81531-90011 : E0590

1st September 1990 : 81531-90011 : E0990

Edition 2 : 1st September 1991 : 81531-90011 : E0991

1st September 1992 : 81531-90011 : E0992

1st December 1994 : 81531-90011 : E1294

1st July 1996: 81531-90011 : E0796

Warranty

This Hewlett-Packard instrument product is warranted against defects in material and workmanship for a period of one year from date of shipment. During the warranty period, HP will, at its option, either repair or replace products that prove to be defective.

For warranty service or repair, this product must be returned to a service facility designated by HP. Buyer shall prepay shipping charges to HP and HP shall pay shipping charges to return the product to Buyer.

However, Buyer shall pay all shipping charges, duties, and taxes for products returned to HP from another country.

HP warrants that its software and firmware designated by HP for use with an instrument will execute its programming instructions when properly installed on that instrument. HP does not warrant that the operation of the instrument, software, or firmware will be uninterrupted or error free.

Limitation of Warranty

The foregoing warranty shall not apply to defects resulting from improper or inadequate maintenance by Buyer, Buyer-supplied software or interfacing, unauthorized modification or misuse, operation outside of the environmental specifications for the product, or improper site preparation or maintenance.

No other warranty is expressed or implied. Hewlett-Packard specifically disclaims the implied warranties of Merchantability and Fitness for a Particular Purpose.

Exclusive Remedies

The remedies provided herein are Buyer's sole and exclusive remedies. Hewlett-Packard shall not be liable for any direct, indirect, special, incidental, or consequential damages whether based on contract, tort, or any other legal theory.

Assistance

Product maintenance agreements and other customer assistance agreements are available for Hewlett-Packard products. For any assistance contact your nearest Hewlett-Packard Sales and Service Office.

Certification

Hewlett-Packard Company certifies that this product met its published specifications at the time of shipment from the factory.

Hewlett-Packard further certifies that its calibration measurements are traceable to the United States National Institute of Standards and Technology, NIST (formerly the United States National Bureau of Standards, NBS) to the extent allowed by the Institutes's calibration facility, and to the calibration facilities of other International Standards Organization members.

ISO 9001 Certification

Produced to ISO 9001 international quality system standard as part of our objective of continually increasing customer satisfaction through improved process control.

Safety Considerations

Before operation, you should review the instrument and manual, including the red safety page, for safety markings and instructions. You must follow these to ensure safe operation and to maintain the instrument in safe condition.

Initial Inspection

Inspect the shipping container for damage. If there is damage to the container or cushioning, you should keep it until you have checked the contents of the shipment for completeness and verified the module both mechanically and electrically.

The Performance Tests give procedures for checking the operation of the module. If the contents are incomplete, mechanical damage or defect is apparent, or if a module does not pass the operator's checks, notify the nearest Hewlett-Packard office.

Warning



To avoid hazardous electrical shock, do not perform electrical tests when there are signs of shipping damage to any portion of the outer enclosure (covers, panels, etc.).

Power Requirements

The HP 81531A operates when installed into the HP 8153A Optical Multimeter mainframe.

Operating Environment

The HP 8153A safety information summarizes the HP 81531A operating environment ranges. In order for the HP 81531A to meet specifications, the operating environment must be within the limits specified in this section.

Input/Output Signals



v

Caution

A maximum of 15V can be applied as an external voltage to any BNC connectors.

**Storage and Shipment**

The module can be stored or shipped at temperatures between -40°C and $+70^{\circ}\text{C}$. The module should be protected from temperature extremes that may cause condensation within it.

Contents

C. HP 81531A Specifications	
Supplementary Performance Characteristics	C-3
Analog output:	C-3
D. Performance Tests	
Introduction	D-1
Equipment Required	D-1
Test Record	D-2
Test Failure	D-2
Instrument Specification	D-2
Performance Test	D-3
Accuracy and Linearity Test	D-3
Test Setup	D-3
I. Accuracy Test	D-4
II. Linearity Test	D-5
III. Noise Test	D-8
E. Cleaning Procedures	
The Cleaning Kit	E-1
Other Cleaning Tools	E-3
Preserving Connectors	E-4
Cleaning Instrument Housings	E-4
Cleaning Procedures	E-5
Cleaning Cable Connectors	E-5
Cleaning Connector Adapters	E-6
Cleaning Connector Interfaces	E-6
How to clean instruments with a recessed lens interface	E-7
Light dirt	E-7
Heavy dirt	E-7

Index

Figures

D-1. Accuracy and Linearity Test Setup	D-4
D-2. Addition of results (example)	D-7

Contents-2

HP 81531A Specifications

Specifications describe the instrument's warranted performance. Supplementary performance characteristics describe the instrument's non-warranted typical performance.

Because of the modular nature of the instrument, these performance specifications apply only to this module. You should insert these pages into the appropriate section of the manual.

HP 81531A Specifications

Sensor Element	In GaAs
Wavelength range	800-1700nm
Power range	+3 to -90dBm
Display resolution	
dBm, dB	0.001
Watt	0.0001 on printout 0.01 to 10 (depending on power range)
Applicable fiber type	9/125 μ m - 100/140 μ m, NA \leq 0.3
Uncertainty (Accuracy)	\pm 2.5% (1000-1650nm) ^[1]
Total Uncertainty	\pm 5% \pm 1.5pW (1000-1650nm) ^[2]
Linearity	(0 to -70dBm)
18°C to 28°C const. temp	\pm 0.015dB \pm 1pW
0°C to 55°C const. temp	\pm 0.05dB \pm 1.5pW
Noise	<1.5pW (1200-1600nm)
peak-peak, avg. time 1sec	
Dimensions	75mm H, 32mm W, 335mm D (2.8" \times 1.3" \times 13.2")
Weight	net 0.6kg (1.3lbs), shipping 1kg (2.2lbs)
Recalibration period	2 years
Warmup time	20 min.

Information on the traceability of power meters is available on request

[1] at the following reference conditions:

- Power level 10 μ W (-20dBm), Continuous Wave (CW).
- Fiber 50 μ m graded index, NA=0.2, fully excited.
- Ambient temperature 23°C \pm 5K.
- Connector Diamond HMS-10/HP.
- At day of calibration (add 0.3% for aging over one year, add 0.6% over two years).
- Spectral width of source <10nm.

[2] at the following operating conditions:

- Fiber \leq 50 μ m, NA \leq 0.2.
- For NA >0.2 add 1%.

C-2 HP 81531A Specifications

- Ambient temperature 0 to 55°C, non-condensing.
- Within 1 year after calibration, add 0.3% for second year.
- For Biconic Connector add $\pm 1\%$.

Supplementary Performance Characteristics

- Add 1% to total uncertainty for the full wavelength range.
- Outside the specified wavelength range, the noise increases by up to 5 times the value shown above.

Analog output:

Bandwidth: \geq DC, \leq 300 to 400Hz, depending on range and sensor module.

Output voltage: 0 to 2V into open.

Output impedance: 600 Ω typical.

Max. input voltage: ± 10 V.

Performance Tests

Introduction

The procedures in this section test the performance of the instrument. The complete specifications to which the HP 81531A is tested are given in Appendix C. All tests can be performed without access to the interior of the instrument. The test equipment given corresponds to tests carried out with Diamond HMS-10/HP connectors.

Equipment Required

Equipment required for the performance test is listed in the table below. Any equipment which satisfies the critical specifications of the equipment given in the table, may be substituted for the recommended models.

<u>Instrument/Accessory</u>	<u>Recommended Model</u>	<u>Required Characteristics</u>
Power Meter Standard #C01	HP 8153A Mainframe with HP 81533A Optical Head Interface Module with HP 81524A Optical Head	Uncertainty $\pm 1.5\%$
Multimeter Mainframe	HP 8153A	
CW Laser Sources	HP 81552SM and HP 81553SM or HP 81554SM	Wavelength Uncertainty $\pm 1.5\text{nm}$
Optical Attenuator	HP 8156 Option 101	
Connector Adapter (head)	HP 81000AA	
Connector Interface	HP 81000AI 4ea (08154-61701)	
Singlemode Fiber	HP 81101AC 2ea	
Plastic Cap	5040-9351 2ea	

Test Record

Results of the performance test may be tabulated on the Test Record provided at the end of the test procedures. It is recommended that you fill out the Test Record and refer to it while doing the test. Since the test limits and setup information are printed on the Test Record for easy reference, the record can also be used as an abbreviated test procedure (if you are already familiar with the test procedures). The Test Record can also be used as a permanent record and may be reproduced without written permission from Hewlett-Packard.

Test Failure

If the HP81531A fails any performance test, return the instrument to the nearest Hewlett-Packard Sales/Service Office for repair.

Instrument Specification

Specifications are the performance characteristics of the instrument which are certified. These specifications, listed in Appendix C, are the performance standards or limits against which the HP 81531A can be tested. Appendix C also lists some supplemental characteristics of the HP 81531A. Supplemental characteristics should be considered as additional information.

Any changes in the specifications due to manufacturing changes, design, or traceability to the National Institute of Standards and Technology (NIST), will be covered in a manual change supplement, or revised manual. Such specifications supercede any that were previously published.

Performance Test

The performance test given in this section includes the Accuracy Test, the Linearity Test, and the Noise Test. Perform each step in the order given, using the corresponding test equipment.

Note



Make sure that all optical connections of the test setups given in the procedure are dry and clean. DO NOT USE INDEX MATCHING OIL.

The optical cables from the laser source to and from the HP 8156A Attenuator to the power meter must be fixed on the table to ensure minimum cable movement during the tests.

Accuracy and Linearity Test

Specifications HP 81531A

Uncertainty : $\pm 2.8\%^\dagger$ (1000-1650nm)

Linearity : $\pm 0.015\text{dB} \pm 1\text{pW}$

† includes aging.

Test Setup

1. Make sure that cable connector, detectors and adapters are clean.
2. Connect the equipment as shown in Figure D-1. Ensure that the cables to and from the attenuator are fixed on the table and that both the optical head and the DUT are close together so that minimum cable movement is required when connecting the cable to the head or to the DUT.

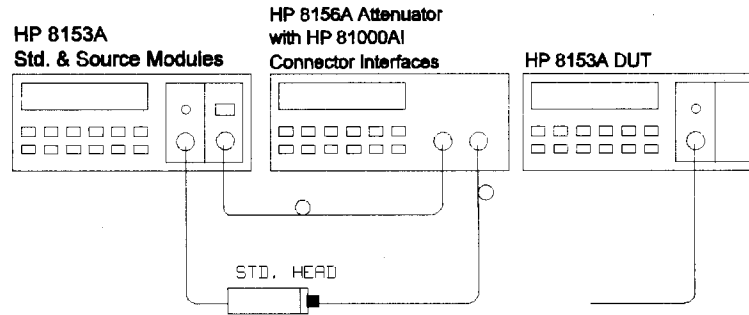

Figure D-1. Accuracy and Linearity Test Setup

3. Turn the instruments on, enable the laser source and allow the instruments to warm up for at least 20 minutes.

Note



The linearity test must only be performed at either 1300nm or 1550nm. The accuracy test must be performed in the -20dBm range at $10\mu\text{W}$ at both 1300nm and 1550nm.

I. Accuracy Test

1. On both power meters:
 - a. Set the calibration factor to zero.
 - b. Set the wavelength to the wavelength of the laser source.
 - c. Set the instruments into MEAS mode. Make sure AUTO-ranging is off and select the -20dBm range.
 - d. Set the averaging time to 500ms.
2. Make sure that the HP 8156A output is disabled. ZERO the DUT.
3. Connect the HP 8156A output cable to the standard head and ZERO the standard meter.
4. Enable the HP 8156A output. Change the HP 8156A attenuation until the power meter standard displays $10.00\mu\text{W}$.
5. Connect the attenuator output cable to the DUT. Check the DUT display and note the result in the test record.
6. Repeat steps 1 to 5 at the second wavelength with the corresponding source.

D-4 Performance Tests

II. Linearity Test

1. Make sure that the HP 8156A output is disabled. ZERO the DUT.
2. Enable the HP 8156A output.
3. On the DUT, switch off autoranging and select the -20dBm range. Set the display to show results in dBm.
4. Alter the attenuation until the DUT displays -17.4dBm.
5. Press **(Disp—Ref)**, then **(dB)**.
6. Press **(Up)** to select the -10dBm range.
7. Note the deviation, displayed in dB, as R1 on the test record.
 - a. In the -10dBm range. Set the display to show results in dBm.
 - b. Alter the attenuation until the DUT displays -7.4dBm.
 - c. Press **(Disp—Ref)**, then **(dB)**.
 - d. Select the 0dBm range.
 - e. Note the deviation, displayed in dB, as R2 on the test record.
8. Repeat the steps a to e at all the range and level settings shown in the test record.
9. Calculate the non-linearity using the formulae in the test record.

Example Results for the Linearity test

D Test No.	Test Description	Minimum Spec.	Result	Maximum Spec.	Measurement Uncertainty
II.	Linearity Test		dB		
	Range Power (dBm)				
	-20dBm -17.4 Disp→Ref		0.004 = R1		
	-10dBm				
	-10dBm -7.4 Disp→Ref		-0.008 = R2		
	0dBm				
	-20dBm -27.4 Disp→Ref		-0.008 = R3		
	-30dBm				
	-30dBm -37.4 Disp→Ref		-0.004 = R4		
	-40dBm				
	-40dBm -47.4 Disp→Ref		0.02 = R5		
	-50dBm				

D-6 Performance Tests

Example Calculated Results for the Linearity Test

D

Test No.	Test Description		Minimum Spec.	Result	Maximum Spec.	Measurement Uncertainty
	Non-Linearity					
	Range	Formula				
	0dBm	R1 + R2	-0.015dB	-0.004dB	+0.015dB	±0.006dB
	-10dBm	R1	-0.015dB	0.004dB	+0.015dB	±0.006dB
	-20dBm			0.000dB		±0.00dB
	-30dBm	R3	-0.015dB	-0.008dB	+0.015dB	±0.006dB
	-40dBm	R3 + R4	-0.015dB	-0.012dB	+0.015dB	±0.008dB
	-50dBm	R3 + R4 + R5	-0.015dB	0.008dB	+0.015dB	±0.010dB

Shown graphically, these results look as shown in the following figure:

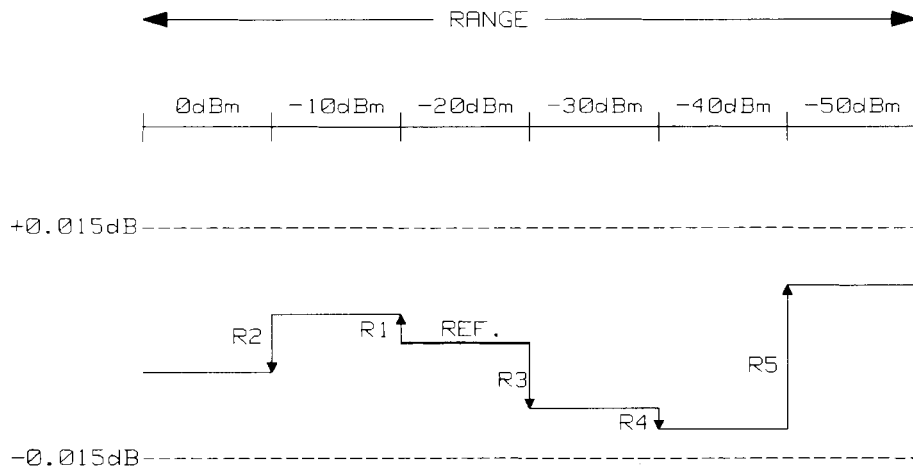

Figure D-2. Addition of results (example)

III. Noise Test

Note

The noise measurement must be performed with either a module or a blank panel in the second channel position.

- Connect the equipment as shown in Figure D-1.
- Disable the HP 8156A output.
- On the DUT, select AUTO-ranging, and display in Watts. Set the averaging time to 1s.
- Press **(Zero)**.
- Select the MENU mode.
- Press **(Record)**, to select Stability.
- Press **(Edit)** and select the T_TOTAL parameter. Set T_TOTAL to 1 minute.
- Press **(Edit)**, and then **(Exec)** to run the noise measurement.
- When the test has completed, press **(More)** to select the SHOW application. Press **(Edit)** and then **(Next)**/**(Prev)** to display the DIFF result.
- Note the DIFF result as the noise value in the test record.

Performance Test for the HP 81531A

Test Facility:

_____	Report No.	_____
_____	Date	_____
_____	Customer	_____
_____	Tested By	_____

Model HP81531A Sensor Module

Serial No. _____ Ambient temperature _____ °C

Options _____ Relative humidity _____ %

Firmware Rev. _____ Line frequency _____ Hz

Special Notes:

Performance Test for the HP 81531A

D

Test Equipment Used:

Description	Model No.	Trace No.	Cal. Due Date
1. Lightwave Multimeter (Std.)	HP 8153A	_____	_____
2. Opt. Head Interface Module	HP 81533A	_____	_____
3. Optical Head	HP 81524A	_____	_____
4a1. CW Laser Source	HP 81552SM	_____	_____
4a2. CW Laser Source	HP 81553SM	_____	_____
4b. CW Laser Source	HP 81554SM	_____	_____
5. Optical Attenuator	HP 8156A		
	Opt.101		
6. Lightwave Multimeter (DUT)	HP 8153A		
7. Connector Interface	HP 81000AI	N/A	N/A
8. Connector Adapter	HP 81000AA	N/A	N/A
9. Singlemode Fiber (2ea)	HP 81101AC	N/A	N/A
12. _____	_____	_____	_____
13. _____	_____	_____	_____
14. _____	_____	_____	_____
15. _____	_____	_____	_____
16. _____	_____	_____	_____
17. _____	_____	_____	_____
18. _____	_____	_____	_____

D-10 Performance Tests

Performance Test for the HP 81531A

D 

Part No. of HP 81531A Sensor Module No. _____ Date _____

Test No.	Test Description	Minimum Spec.	Result	Maximum Spec.	Measurement Uncertainty
I.	Accuracy Test		μW		
	measured at _____ nm Output Power	9.72 μW	_____	10.28 μW	$\pm 2\%$
	measured at _____ nm Output Power	9.72 μW	_____	10.28 μW	$\pm 2\%$
II.	Linearity Test		dB		
	Range Power (dBm)				
	-20dBm -17.4 Disp→Ref		_____ = R1		
	-10dBm				
	-10dBm -7.4 Disp→Ref		_____ = R2		
	0dBm				
	-20dBm -27.4 Disp→Ref		_____ = R3		
	-30dBm				
	-30dBm -37.4 Disp→Ref		_____ = R4		
	-40dBm				
	-40dBm -47.4 Disp→Ref		_____ = R5		
	-50dBm				

Performance Test for the HP 81531A

D

Model HP 81531A Sensor Module No. _____ Date _____

Test No.	Test Description	Minimum Spec.	Result	Maximum Spec.	Measurement Uncertainty
	Non-Linearity				
	Range Formula				
	0dBm R1 + R2	-0.015dB	_____dB	+0.015dB	±0.006dB
	-10dBm R1	-0.015dB	_____dB	+0.015dB	±0.006dB
	-20dBm		0.000dB		0.00dB
	-30dBm R3	-0.015dB	_____dB	+0.015dB	±0.006dB
	-40dBm R3 + R4	-0.015dB	_____dB	+0.015dB	±0.008dB
	-50dBm R3 + R4 + R5	-0.015dB	_____dB	+0.015dB	±0.010dB
III.	Noise Test		_____pW	<1.5pW	

Cleaning Procedures

The Cleaning Kit

A full cleaning kit contains the following items:

Isopropyl alcohol This is usually available from pharmaceutical suppliers or chemists.

If possible, use alcohol supplied for medical purposes, rather than impure alcohol or alcohol with additives.

Caution

Do not use other solvents as some can damage plastic materials and claddings. For example, Acetone dissolves the adhesives used in fiber optic devices.

Warning

Never drink this alcohol as this can lead to blindness or other serious damage to your health.

Cotton-swabs

Use swabs such as Q-tips or other cotton-swabs. These are typically available from local distributors of medical or hygiene products (such as supermarkets or pharmacies).

Note If you are cleaning connector interfaces or adapters, the diameter of the cotton swab is important. Cotton swabs for babies normally have a smaller diameter.

Caution

- Do not use foam swabs, as these can leave filmy deposits on the surface you are cleaning.
- Store your cotton-swabs carefully and never reuse them. Dust and dirt from the air or from previous cleaning, can scratch or dirty your optical device.

Soft-tissues

These are available from most stores and distributors of medical and hygiene products (such as supermarkets or pharmacies).

Use multi-layer tissues made from non-recycled cellulose. These are more absorbent and softer than other types and they do not scratch the surface of your device.

Caution

Store your soft-tissues carefully and never reuse them, as dust and dirt from the air or from previous cleaning can scratch and dirty your optical device.

Pipe-cleaner

This is available from tobacco shops.

Ensure that the bristles of the pipe-cleaner are soft, so that they do not scratch your device during cleaning.

Caution

Store your pipe-cleaners carefully and never reuse them as dust and dirt from the air or from previous cleaning can scratch and dirty your optical device.

E**Compressed Air**

This is available from laboratory suppliers.

It is essential that your compressed air is free of dust, water and oil. Only use clean, dry air. If you do not, it can lead to filmy deposits or scratches.

When using compressed air from a can,

- Hold the can upright. A slant can cause propellant to escape with the compressed air and dirty your optical device.
- Spray the first couple of seconds into the air, as the first stream of compressed air can contain condensation or propellant. Any condensation produces a filmy deposit.

If you are using compressed air from a can, you should select one with a CFC-free propellant, for the sake of the environment.

E:2 Cleaning Procedures

Other Cleaning Tools

To examine devices you also require:

- Microscope** Select a microscope with a magnification range of between 50X and 300X. These should be available from photographic stores or laboratory suppliers.
- Ensure that the light source of the microscope is flexible. This helps you to examine your device closely and from different angles.
- A microscope allows you to determine the type of dirt on your device and its extent. Then you can choose the correct cleaning procedure and later to examine the results of cleaning. With a microscope you can also determine if your optical device is scratched.
- Ultrasonic bath** This is typically available from photographic stores or laboratory suppliers.
- An ultrasonic bath very gently removes greasy and other stubborn dirt from optical devices.
- Only use an ultrasonic bath with isopropyl alcohol, as other solvents can damage or dirty your optical device.
- Warm water and liquid soap** Use water only if you are sure that your optical device will not corrode or be damaged. Do not use hot water, as this can lead to mechanical stress that can damage your optical device. Ensure that your liquid soap has no abrasive properties or perfume in it, as these can scratch or damage your optical device. Do not use normal washing-up liquid, as it can leave behind an iridescent film.
- Premoistened cleaning wipes** These are available from HP. The part number is HP 92193N (80 Wipes per box). These are tissues that are moistened with isopropyl alcohol.
- Polymer film** This is typically available from professional photographic stores or laboratory suppliers.
- Polymer film is very gentle on optical surfaces and is particularly good for cleaning extremely sensitive devices such as mirrors.
- Infrared sensor card** This is typically available from laboratory suppliers.
- With this card you can qualitatively check the uniformity of your emitted laser light, because when the laser light is projected onto the sensor card it becomes visible.
- Lens Cleaning Paper** Some lens cleaning papers and cleaning kits available, for example, in photographic stores are not suitable for cleaning fiber optic devices. To be sure, please ask the salesperson or the manufacturer.

E

Preserving Connectors

Listed below are some hints on how to keep your connectors in the best possible condition.

E	Making Connections	Before you make any connection you must ensure that all cables and connectors are clean. If they are dirty, use the appropriate cleaning procedure.
		When inserting the ferrule of a patchcord into a connector or an adapter, make sure that the fiber end does not touch the outside of the mating connector or adapter. Otherwise you will rub the fiber end against an unsuitable surface, producing scratches and dirt deposits on the surface of your fiber.
	Dust Caps and Shutter Caps	Be careful when replacing dust caps after use. Do not press the bottom of the cap onto the fiber as any dust in the cap can scratch or dirty your fiber surface. When you have finished cleaning, put the dust cap back on, or close the shutter cap if the equipment is not going to be used immediately. Keep the caps on the equipment always when it is not in use. All of Hewlett-Packard's lightwave instruments and accessories are shipped with either laser shutter caps or dust caps. If you need additional or replacement dust caps, contact your Hewlett-Packard sales office.
	Immersion Oil and Other Index Matching Compounds	Where it is possible, do not use immersion oil or other index matching compounds with your device. They are liable to impair and dirty the surface of the device. In addition, the characteristics of your device can be changed and your measurement results affected.

Cleaning Instrument Housings

Use a dry and very soft cotton tissue to clean the instrument housing and the keypad. Do not open the instruments as there is a danger of electric shock, or electrostatic discharge. Opening the instrument can cause damage to sensitive components, and in addition your warranty will be voided.

Cleaning Procedures

If you are unsure about the correct cleaning procedure for your device or if you are unsure whether the procedure given here is suitable for your device, check with the manufacturer or sales distributor, or try the procedure on a dummy or test device first.

Cleaning Cable Connectors

Cleaning connectors is difficult as the core diameter of a singlemode fiber is only about $9\mu\text{m}$. This generally means you cannot see streaks or scratches on the surface. To be certain of the condition of the surface of your connector and to check it after cleaning, you need a microscope.

In the case of scratches, or of dust that has been burnt onto the surface of the connector, you may have no option but to polish the connector. This depends on the degree of dirtiness, or the depth of the scratches. This is a difficult procedure and should only be performed by skilled personnel, and as a last resort as it wears out your connector.

Warning

Never look into the end of an optical cable that is connected to an active source.

To assess the projection of the emitted light beam you can use an infrared sensor card. Hold the card approximately 5 cm from the output of the connector. The invisible emitted light is projected onto the card and becomes visible as a small circular spot.

Preferred Procedure

1. Clean the connector by rubbing a new, dry cotton-swab over the surface using a small circular movement.
2. Blow away any remaining lint with compressed air.

Procedure for Stubborn Dirt

Use this procedure particularly when there is greasy dirt on the connector:

1. Moisten a new cotton-swab with isopropyl alcohol.
2. Clean the connector by rubbing the cotton-swab over the surface using a small circular movement.
3. Take a new, dry soft-tissue and remove the alcohol, dissolved sediment and dust, by rubbing gently over the surface using a small circular movement.
4. Blow away any remaining lint with compressed air.

An Alternative Procedure

The better, more gentle, but more expensive cleaning procedure is to use an ultrasonic bath with isopropyl alcohol.

1. Hold the tip of the connector in the bath for at least three minutes.
2. Take a new, dry soft-tissue and remove the alcohol, dissolved sediment and dust, by rubbing gently over the surface using a small circular movement.
3. Blow away any remaining lint with compressed air.

E

Cleaning Connector Adapters

Caution

Some adapters have an anti-reflection coating on the back to reduce back reflection. This coating is extremely sensitive to solvents and mechanical abrasion. Extra care is needed when cleaning these adapters.

E

Preferred Procedure

1. Clean the adapter by rubbing a new, dry cotton-swab over the surface using a small circular movement.
2. Blow away any remaining lint with compressed air.

Procedure for Stubborn Dirt

Use this procedure particularly when there is greasy dirt on the adapter:

1. Moisten a new cotton-swab with isopropyl alcohol.
2. Clean the adapter by rubbing the cotton-swab over the surface using a small circular movement.
3. Take a new, dry soft-tissue and remove the alcohol, dissolved sediment and dust, by rubbing gently over the surface using a small circular movement.
4. Blow away any remaining lint with compressed air.

Cleaning Connector Interfaces

Caution

- Be careful when using pipe-cleaners, as the core and the bristles of the pipe-cleaner are hard and can damage the interface.
- Do not use pipe-cleaners on optical head adapters, as the hard core of normal pipe cleaners can damage the bottom of an adapter.

Preferred Procedure

1. Clean the interface by pushing and pulling a new, dry pipe-cleaner into the opening. Rotate the pipe-cleaner slowly as you do this.
2. Then clean the interface by rubbing a new, dry cotton-swab over the surface using a small circular movement.
3. Blow away any remaining lint with compressed air.

Procedure for Stubborn Dirt

Use this procedure particularly when there is greasy dirt on the interface:

1. Moisten a new pipe-cleaner with isopropyl alcohol.
2. Clean the interface by pushing and pulling the pipe-cleaner into the opening. Rotate the pipe-cleaner slowly as you do this.
3. Moisten a new cotton-swab with isopropyl alcohol.
4. Clean the interface by rubbing the cotton-swab over the surface using a small circular movement.
5. Using a new, dry pipe-cleaner, and a new, dry cotton-swab remove the alcohol, any dissolved sediment and dust.
6. Blow away any remaining lint with compressed air.

How to clean instruments with a recessed lens interface

Light dirt

If you find any particles of dirt on the fixed connector interface, or on the input of the optical block, clean them with compressed air.

This cleaning method is gentle to your optical device and is an ideal approach if there is no fat on the surface of your device.

Heavy dirt

Using compressed air, blow away larger particles of dirt. Clean the recessed lens interface with a dry cotton swab by rubbing gently over its surface. Then blow away any remaining filaments left by the swab.

Isopropyl alcohol should only be used if there is fat on the lens. In this case, choose a new swab and moisten it with alcohol. Remove the dirt by gently rotating the swab using light pressure. Then select a fresh, dry swab to wipe away the alcohol. Blow away any remaining filament with compressed air.

Caution



Do not press the swabs too hard onto the optical surface of your device, as this may produce scratches and your recessed lens could be misaligned.

Alcohol will dissolve some types of dirt. If this then forms a deposit on the edge of the optical input it cannot be removed. You should therefore only use alcohol if absolutely necessary.

Other solvents, like Acetone, should also not be used, as they may damage your optical device and reduce its performance.

E

