

Subject: I-V w500w vs. Solar I-Ve

Overview: HT instruments provides 2 options for testing I-V curves on PV panels and strings, our I-V 500w and the Solar I-Ve. This overview is intended to clearly identify the differences in these 2 products and make the choice easier.

The key difference is that the Solar I-Ve, in addition to being an I-V curve tracer, also has power analyzer efficiency functionality and the ability to link to the HT MPP300 power analyzer (below).

As can be seen on the right, the Solar I-Ve can measure Irradiance, DC power out of the field and finally power out of the inverter. (single Phase)

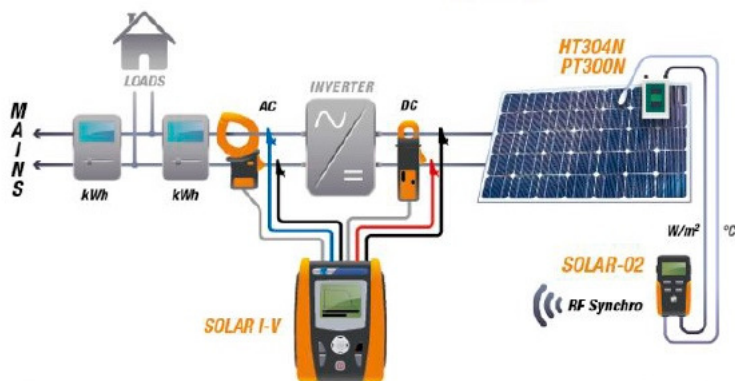

The Solar I-Vw also can work with our MPP300 power accessory. This configuration allows for the testing of 3 phase out to the grid as well as 3 separate DC power paths into the inverter.

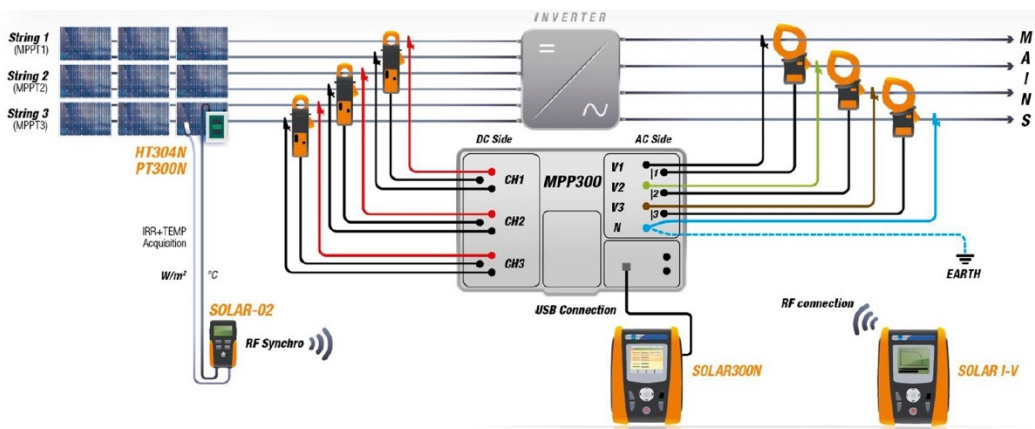

So both the I-V500w and the Solar I-Ve have the same standard accessories for testing I-V curves. In addition the Solar I-Ve has needed accessories as follows:

- PT300 Temperature Probe
- Solar 02 remote acquisition system
- HT4004N DC Current Clamp 10A/100Z
- HT 4005K AC Current Clamp up to 200A

The combined value of these added accessories list for >\$1,500.

Standard Accessories for Curve tracing included in both the I-V 400w and Solar I-Vw are:

- HT304N Reference cell for measurement of irradiance.
- M304 Inclinations checker
- VA500 Hard Case
- KitPVMC4 Connectors
- KitPVMC3 Connectors
- KitGSC4 connectors with Alligator clips
- Top View Software
- Calibration Certificates