Safety Symbols	6
WARNINGS	6
Declaration of Conformity	7
Reader Comment Sheet	9
Chapter 1	
Introduction	11
Using the IEEE 1394 Serial Bus in VXI Systems	11
Component Overview	11
The HP E8491B PC Link to VXI Interconnect	11
The OHCI-Compatible PCI-to-IEEE 1394 Host Adapter	11
The HP I/O Libraries	11
Using this Manual	11
Chapter 2: Interface Installation and Configuration	11
Chapter 3: VXI Programming Using the IEEE 1394 Serial Bus	12
Chapter 4: IEEE 1394 Fundamentals and Interface Overview	12
Appendix A: Specifications	12
Appendix B: Editing the HP E8491B Resource Manager Configuration	12
Additional Information	12
Chapter 2	
Interface Installation and Configuration	13
Using this Chapter	13
Step 1: Installing the IEEE 1394Host Adapter	13
Where to go Next	17
Step 2: Installing the HP E8491B Interconnect	17
Alternate Configurations	19
Where to go Next	20
Step 3: Installing VXI Instruments	20
Installing C-size Instruments	21
Installing A- and B-size Instruments	22
Step 4: Installing the HP I/O Libraries	24
Configuring the HP E8491B Interconnect	24
Editing the HP E8491B Configuration	26
Editing the HP E8491B Configuration on Windows 95 Platforms	27
Step 5: Installing HP VXIplug&play Instrument Drivers	28
Step 6. Verifying the Installation	29
Using Instrument Soft Front Panels	29
Viewing the Resource Manager Output	30
Troubleshooting Installation Problems	33
Running the Resource Manager	33

Chapter 3	
VXI Programming Using the IEEE 1394 Serial Bus	35
Using this Chapter	35
Programming Register-Based and Message-Based VXI Instruments	35
Opening Instrument Sessions	35
Optimizing Programs	36
Block Data Transfers	36
Block Transfers using HP VXIplug&play Drivers	37
Block Transfers using HP VISA	40
HP E8491B Triggering	43
Using Triggers	43
Configuring the E8491B Trig In and Trig Out Ports	44
Triggering Example	45
Trigger Pull Up	47
Using HP E8491B Shared Memory	47
Locating E8491B Shared Memory	47
Example Programs	49
Storing Readings in Shared Memory - HP VISA Example	50
Storing Readings in Shared Memory - SICL Example	54
Chapter 4	
IEEE 1394 Fundamentals and Interface Overview	57
Using this Chapter	57
IEEE 1394 Topology and Terminology	57
Features of the IEEE 1394 Bus	58
Optimizing the Configuration	59
IEEE 1394 Data Transfer Protocol	59
Asynchronous Data Transfers	60
Fair Arbitration Protocol	60
VXI Data Transfers	60
OHCI-Compatible Host Adapter and Interface Cable	61
The HP E8491B PC to VXI Interconnect	62
Using the HP E8491B with the HP E1406 Command Module	64
The HP I/O Libraries	64
Appendix A	
Specifications	65
Interface Characteristics	65
VXI Characteristics	65
General	65
CLK 10	66
External Trigger Input	66
External Trigger Output	66
Trigger Delays	67
Cooling	67
Power Supply Loading	67

Appendix B	
Editing the HP E8491B Resource Manager Configuration	69
Introduction.....	69
Configuration File Overview	69
The names.cf Configuration File	72
The oride.cf Configuration File	72
The vmedev.cf Configuration File	72
The cmdrsrvt.cf Configuration File	72
The dynamic.cf Configuration File	72
The irq.cf Configuration File	73
The tltrig.cf Configuration File	73
The vximanuf.cf Configuration File	73
The vximodel.cf Configuration File	73
Utility Function Overview	73
Using ivxisc	73
Using iclear	75
 Index	 77

HEWLETT-PACKARD WARRANTY STATEMENT

HP PRODUCT: HP E8491B IEEE 1394 PC LINK to VXI **DURATION OF WARRANTY:** 3 years

1. HP warrants HP hardware, accessories and supplies against defects in materials and workmanship for the period specified above. If HP receives notice of such defects during the warranty period, HP will, at its option, either repair or replace products which prove to be defective. Replacement products may be either new or like-new.

2. HP warrants that HP software will not fail to execute its programming instructions, for the period specified above, due to defects in material and workmanship when properly installed and used. If HP receives notice of such defects during the warranty period, HP will replace software media which does not execute its programming instructions due to such defects.

3. HP does not warrant that the operation of HP products will be interrupted or error free. If HP is unable, within a reasonable time, to repair or replace any product to a condition as warranted, customer will be entitled to a refund of the purchase price upon prompt return of the product.

4. HP products may contain remanufactured parts equivalent to new in performance or may have been subject to incidental use.

5. The warranty period begins on the date of delivery or on the date of installation if installed by HP. If customer schedules or delays HP installation more than 30 days after delivery, warranty begins on the 31st day from delivery.

6. Warranty does not apply to defects resulting from (a) improper or inadequate maintenance or calibration, (b) software, interfacing, parts or supplies not supplied by HP, (c) unauthorized modification or misuse, (d) operation outside of the published environmental specifications for the product, or (e) improper site preparation or maintenance.

7. TO THE EXTENT ALLOWED BY LOCAL LAW, THE ABOVE WARRANTIES ARE EXCLUSIVE AND NO OTHER WARRANTY OR CONDITION, WHETHER WRITTEN OR ORAL, IS EXPRESSED OR IMPLIED AND HP SPECIFICALLY DISCLAIMS ANY IMPLIED WARRANTY OR CONDITIONS OF MERCHANTABILITY, SATISFACTORY QUALITY, AND FITNESS FOR A PARTICULAR PURPOSE.

8. HP will be liable for damage to tangible property per incident up to the greater of \$300,000 or the actual amount paid for the product that is the subject of the claim, and for damages for bodily injury or death, to the extent that all such damages are determined by a court of competent jurisdiction to have been directly caused by a defective HP product.

9. TO THE EXTENT ALLOWED BY LOCAL LAW, THE REMEDIES IN THIS WARRANTY STATEMENT ARE CUSTOMER'S SOLE AND EXCLUSIVE REMEDIES. EXCEPT AS INDICATED ABOVE, IN NO EVENT WILL HP OR ITS SUPPLIERS BE LIABLE FOR LOSS OF DATA OR FOR DIRECT, SPECIAL, INCIDENTAL, CONSEQUENTIAL (INCLUDING LOST PROFIT OR DATA), OR OTHER DAMAGE, WHETHER BASED IN CONTRACT, TORT, OR OTHERWISE.

FOR CONSUMER TRANSACTIONS IN AUSTRALIA AND NEW ZEALAND: THE WARRANTY TERMS CONTAINED IN THIS STATEMENT, EXCEPT TO THE EXTENT LAWFULLY PERMITTED, DO NOT EXCLUDE, RESTRICT OR MODIFY AND ARE IN ADDITION TO THE MANDATORY STATUTORY RIGHTS APPLICABLE TO THE SALE OF THIS PRODUCT TO YOU.

U.S. Government Restricted Rights

The Software and Documentation have been developed entirely at private expense. They are delivered and licensed as "commercial computer software" as defined in DFARS 252.227- 7013 (Oct 1988), DFARS 252.211-7015 (May 1991) or DFARS 252.227-7014 (Jun 1995), as a "commercial item" as defined in FAR 2.101(a), or as "Restricted computer software" as defined in FAR 52.227-19 (Jun 1987)(or any equivalent agency regulation or contract clause), whichever is applicable. You have only those rights provided for such Software and Documentation by the applicable FAR or DFARS clause or the HP standard software agreement for the product involved.

HP E8491B IEEE 1394 PC Link to VXI Configuration and User's Guide



Edition 2

Copyright © 1999 Hewlett-Packard Company. All Rights Reserved.

Documentation History

All Editions and Updates of this manual and their creation date are listed below. The first Edition of the manual is Edition 1. The Edition number increments by 1 whenever the manual is revised. Updates, which are issued between Editions, contain replacement pages to correct or add additional information to the current Edition of the manual. Whenever a new Edition is created, it will contain all of the Update information for the previous Edition. Each new Edition or Update also includes a revised copy of this documentation history page.

Edition 1 June 1998

Edition 2 June 1999

Safety Symbols



Instruction manual symbol affixed to product. Indicates that the user must refer to the manual for specific **WARNING** or **CAUTION** information to avoid personal injury or damage to the product.



Indicates the field wiring terminal that must be connected to earth ground before operating the equipment—protects against electrical shock in case of fault.

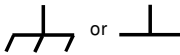

Frame or chassis ground terminal—typically connects to the equipment's metal frame.



Alternating current (AC)



Direct current (DC).



Indicates hazardous voltages.

WARNING

Calls attention to a procedure, practice, or condition that could cause bodily injury or death.

CAUTION

Calls attention to a procedure, practice, or condition that could possibly cause damage to equipment or permanent loss of data.

WARNINGS

The following general safety precautions must be observed during all phases of operation, service, and repair of this product. Failure to comply with these precautions or with specific warnings elsewhere in this manual violates safety standards of design, manufacture, and intended use of the product. Hewlett-Packard Company assumes no liability for the customer's failure to comply with these requirements.

Ground the equipment: For Safety Class 1 equipment (equipment having a protective earth terminal), an uninterruptible safety earth ground must be provided from the mains power source to the product input wiring terminals or supplied power cable.

DO NOT operate the product in an explosive atmosphere or in the presence of flammable gases or fumes.

For continued protection against fire, replace the line fuse(s) only with fuse(s) of the same voltage and current rating and type. DO NOT use repaired fuses or short-circuited fuse holders.

Keep away from live circuits: Operating personnel must not remove equipment covers or shields. Procedures involving the removal of covers or shields are for use by service-trained personnel only. Under certain conditions, dangerous voltages may exist even with the equipment switched off. To avoid dangerous electrical shock, DO NOT perform procedures involving cover or shield removal unless you are qualified to do so.

DO NOT operate damaged equipment: Whenever it is possible that the safety protection features built into this product have been impaired, either through physical damage, excessive moisture, or any other reason, REMOVE POWER and do not use the product until safe operation can be verified by service-trained personnel. If necessary, return the product to a Hewlett-Packard Sales and Service Office for service and repair to ensure that safety features are maintained.

DO NOT service or adjust alone: Do not attempt internal service or adjustment unless another person, capable of rendering first aid and resuscitation, is present.

DO NOT substitute parts or modify equipment: Because of the danger of introducing additional hazards, do not install substitute parts or perform any unauthorized modification to the product. Return the product to a Hewlett-Packard Sales and Service Office for service and repair to ensure that safety features are maintained.

Declaration of Conformity
according to ISO/IEC Guide 22 and EN 45014

Manufacturer's Name: Hewlett-Packard Company
Loveland Manufacturing Center

Manufacturer's Address: 815 14th Street S.W.
Loveland, Colorado 80537

declares, that the product:

Product Name: IEEE 1394 PC Link to VXI

Model Number: HP E8491B

Product Options: All

conforms to the following Product Specifications:

Safety: IEC 61010-1 (1990) + A1:1992 + A2:1995/EN61010-1 + A1:1993 + A2:1995
CSA C22.2 #1010.1:1992
UL 3111-1
IEC 60950:1991 + A1:1992 + A2:1993 + A3:1994 + A4:1996/
EN60950:1992 + A1:1993 + A2:1993 + A3:1995 + A4:1997
UL 1950

EMC: CISPR 22:1993 + A1:1995/EN55022:1992 + A1:1995 : Class A
CISPR 11:1990/EN55011 (1991): Group1 Class A
EN50082-1:1997
IEC 61000-4-2:1995/: 4kVCD, 8kVAD
IEC 61000-4-3:1995/: 3 V/m
IEC 61000-4-4:1995/: 1kV Power Line, 0.5kV Signal Lines
IEC 61000-4-5:1995/: 1kV, CM 0.5 kV DM
IEC 61000-4-6:1996/: 3 Vrms
IEC 61000-4-11:1994/: 30%, 10ms 80%, 100ms

Supplementary Information: The product herewith complies with the requirements of the Low Voltage Directive 73/23/EEC and the EMC Directive 89/336/EEC (inclusive 93/68/EEC) and carries the "CE" mark accordingly.

Tested in a typical configuration in an HP C-Size VXI mainframe.



Jim White, QA Manager

March 5, 1999



For Compliance Information ONLY, contact:

Australian Contact: Product Regulations Manager, Hewlett-Packard Australia Ltd., 31-41 Joseph Street, Blackburn, Victoria 3130, Australia

European Contact: Your local Hewlett-Packard Sales and Service Office or Hewlett-Packard GmbH, Department HQ-TRE, Herrenberger Straße 130, D-71034 Böblingen, Germany (FAX +49-7031-14-3143)

USA Contact: Product Regulations Manager, Hewlett-Packard Company, P.O. Box 301, Mail Stop BU212, Loveland, CO 80537

Notes:

Please fold and tape for mailing

Reader Comment Sheet

HP E8491B IEEE 1394 PC Link to VXI Configuration and User's Guide
Edition 2

You can help us improve our manuals by sharing your comments and suggestions. **In appreciation of your time, we will enter you in a quarterly drawing for a Hewlett-Packard Palmtop Personal Computer** (U.S. government employees are not eligible for the drawing).

_____	_____
Your Name	City, State/Province
_____	_____
Company Name	Country
_____	_____
Job Title	Zip/Postal Code
_____	_____
Address	Telephone Number with Area Code

Please list the system controller, operating system, programming language, and plug-in modules you are using.

fold here



NO POSTAGE NECESSARY IF MAILED IN THE UNITED STATES

BUSINESS REPLY MAIL
FIRST CLASS PERMIT NO. 37 LOVELAND, CO

POSTAGE WILL BE PAID BY ADDRESSEE

HEWLETT-PACKARD COMPANY

Measurement Systems Division
Learning Products Department
P.O. Box 301
Loveland, CO 80539-9984

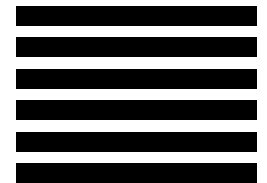

cut along this line



fold here

Please pencil-in one circle for each statement below:

- The documentation is well organized.
- Instructions are easy to understand.
- The documentation is clearly written.
- Examples are clear and useful.
- Illustrations are clear and helpful.
- The documentation meets my overall expectations.

Disagree ←————→ Agree

<input type="radio"/>	<input type="radio"/>	<input type="radio"/>	<input type="radio"/>	<input type="radio"/>
<input type="radio"/>	<input type="radio"/>	<input type="radio"/>	<input type="radio"/>	<input type="radio"/>
<input type="radio"/>	<input type="radio"/>	<input type="radio"/>	<input type="radio"/>	<input type="radio"/>
<input type="radio"/>	<input type="radio"/>	<input type="radio"/>	<input type="radio"/>	<input type="radio"/>
<input type="radio"/>	<input type="radio"/>	<input type="radio"/>	<input type="radio"/>	<input type="radio"/>
<input type="radio"/>	<input type="radio"/>	<input type="radio"/>	<input type="radio"/>	<input type="radio"/>

Please write any comments or suggestions below—be specific.

Using the IEEE 1394 Serial Bus in VXI Systems

The IEEE 1394 Serial Bus (FireWire) is a high-speed bus that has been implemented as an I/O interface between external PCs and HP VXI systems. The bus links the PC backplane to the VXI mainframe backplane. This manual describes the implementation, configuration, and use of this interface.

Component Overview

Implementation of the IEEE 1394 serial bus as an I/O interface for HP VXI systems is provided through three components and two operating systems:

- HP E8491B PC Link to VXI Interconnect
- OHCI-compatible PCI-to-IEEE 1394 Host Adapter
- HP I/O Libraries
- WIN 95 and WIN NT operating systems

The HP E8491B PC Link to VXI Interconnect

The HP E8491B is the VXI hardware that links the VXI mainframe backplane to the IEEE 1394 serial bus. The E8491B is a 1-slot, C-size, message-based device that is installed in mainframe slot 0.

The OHCI-Compatible PCI-to-IEEE 1394 Host Adapter

The OHCI PCI-to-1394 Host Adapter card is installed in the PC and links the computer's (PCI) backplane to the IEEE 1394 bus. The OHCI adapter has three external IEEE 1394 ports and can support up to 16 HP E8491Bs.

The HP I/O Libraries

The HP I/O Libraries provide the HP VISA and HP SICL drivers required to use the HP E8491B. Included with the libraries are the drivers for the OHCI-compatible host adapter.

Using this Manual

This manual is organized to help you install, configure, and begin using the IEEE 1394 serial bus as quickly and efficiently as possible. The following information outlines the contents of the other chapters, and identifies the areas of programming a VXI system that are NOT covered in this manual.

Chapter 2: Interface Installation and Configuration

This chapter contains information on installing the HP E8491B hardware and its drivers (the HP I/O Libraries). Also included is information on installing VXI instruments, installing HP VXI*plug&play* drivers, and on verifying the system.

Chapter 3: VXI Programming Using the IEEE 1394 Serial Bus

This chapter contains the information necessary to begin communicating with VXI instruments through the HP E8491B and IEEE 1394 serial bus. The chapter contains information on optimizing system performance using block data transfers, and also covers triggering and using HP E8491B shared memory.

Chapter 4: IEEE 1394 Fundamentals and Interface Overview

This chapter describes the IEEE 1394 serial bus and how it is implemented in HP VXI systems. It defines the bus terminology and data transfer protocol.

Appendix A: Specifications

Appendix A contains the operating and performance specifications of the HP E8491B.

Appendix B: Editing the HP E8491B Resource Manager Configuration

Appendix B contains information on editing your VXI system configuration as set by the resource manager. It describes selected configuration files and utility functions used to view and modify your configuration.

Additional Information

Programming the HP E8491B is through HP VISA and HP SICL functions. Although this manual identifies the specific functions used, you will need to refer to the HP VISA and HP SICL manuals for detailed information.

Also, included with the HP I/O Libraries is the utility 'I_O Config'. This utility is used to configure the HP E8491B and has a help file associated with it.

Note

Pop-up or pull-down menus displayed by the HP I/O Libraries software will show I/O Libraries as "I_O Libraries" and I/O Config as "I_O Config" because the "/" cannot be displayed. The "/" character is therefore replaced by the underscore character.

Interface Installation and Configuration

Using this Chapter

This chapter contains information necessary to install and configure the IEEE 1394 host adapter (if required) and the HP E8491B interconnect. The installation sequence and other topics covered in this chapter are as follows:

- Step 1: Installing the IEEE 1394 Host Adapter 13
- Step 2: Installing the HP E8491B Interconnect 17
- Step 3: Installing VXI Instruments 20
- Step 4: Installing the HP I/O Libraries 24
- Step 5: Installing HP VXI*plug&play* Instrument Drivers . . . 28
- Step 6: Verifying the Installation 29
- Running the Resource Manager 33

Step 1: Installing the IEEE 1394 Host Adapter

The IEEE 1394 adapter shipped as Option 001 to the HP E8491B is an OHCI-compatible PCI-to-IEEE 1394 Host Adapter. Included with the adapter is a cable for powering IEEE 1394 devices and a 4.5m interface cable.

WARNING Refer to your computer's documentation for specific instructions about the installation of PCI adapters.

Note If your personal computer (PC) currently has a Solectron OHCI403 PCI-to-IEEE 1394 host adapter, a later version OHCI-compatible PCI-to-IEEE 1394 host adapter or a built-in IEEE 1394 port, proceed to Step 2: Installing the HP E8491 Interconnect.

The layout of a typical host adapter is shown in Figure 2-1.

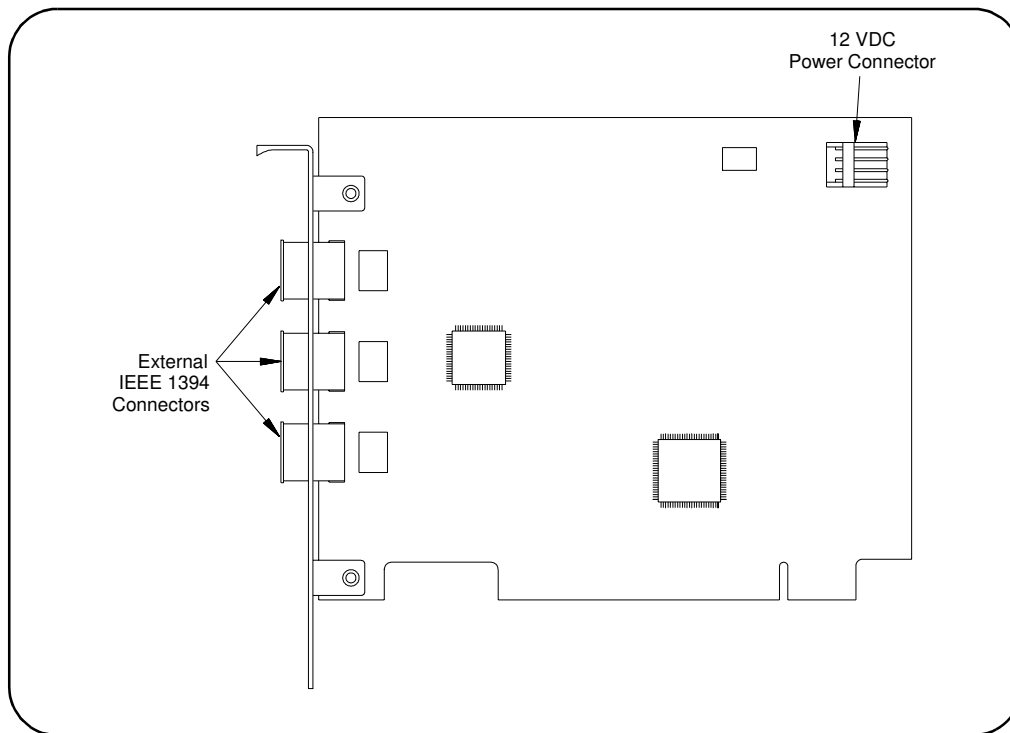

Figure 2-1. Layout of a Typical OHCI-Compatible PCI-to-IEEE 1394 Host Adapter.

WARNING Turn off and disconnect the power to your computer and to any peripheral devices before installing the host adapter. Refer to your computer's documentation for specific instructions about the installation of PCI adapters.

1. Remove the computer chassis cover to expose the expansion slots and external access covers.
2. Locate an unused, unobstructed PCI bus expansion slot (Figure 2-2) that supports bus mastering. (PCI bus slots are usually white or ivory.) See your computer documentation to determine if the PCI slot supports bus mastering.

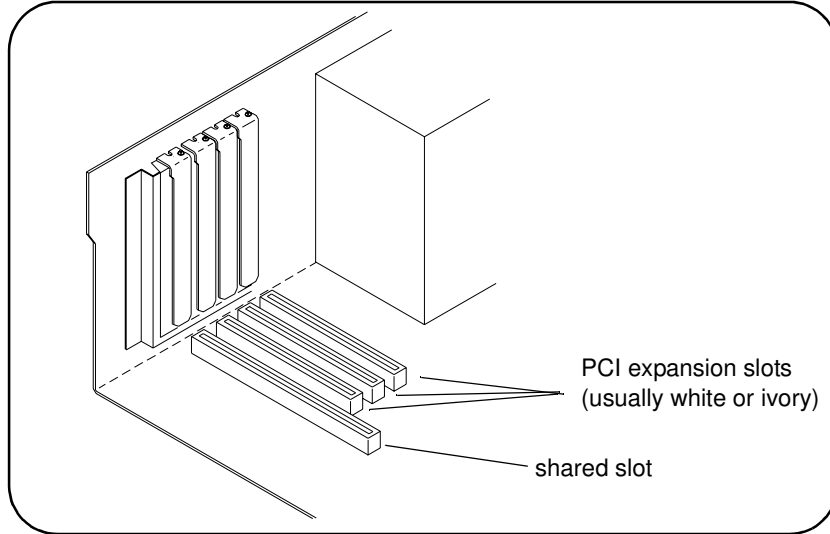

Figure 2-2. Locating a PCI bus Expansion Slot.

Note Many computer PCI systems have one pair of ISA and PCI slots close to each other. This saves space and allows you to install either an ISA card or a PCI card in the slot pair.

3. Remove the corresponding expansion slot cover from the computer chassis (Figure 2-3).

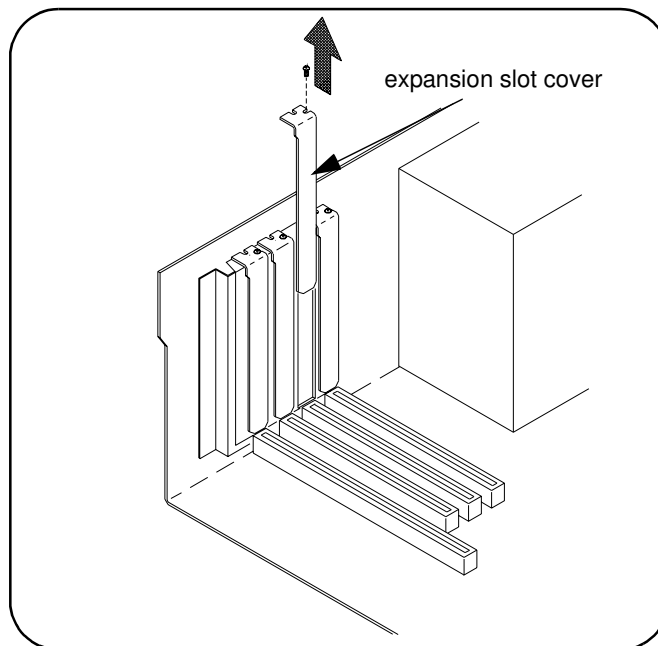

Figure 2-3. Removing the PC Expansion Slot Cover.

4. Align the bus contacts on the bottom of the host adapter with the PCI bus slot. Carefully, but firmly, press the adapter into the slot.

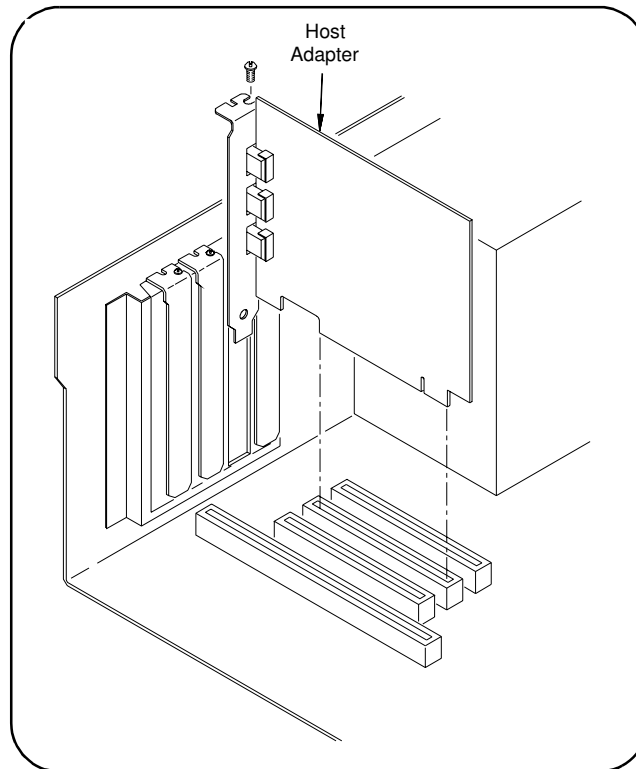

Figure 2-4. Installing the Host Adapter.

5. Secure the host adapter bracket to the computer chassis with the screw from the expansion slot cover removed in step C.

Connecting the Power Cable

6. Connect the power cable between the adapter and the PC as shown in Figure 2-5. This provides power from the adapter to devices along the interface via the interface cable. This allows you to cycle power on any VXI mainframe in multi-frame systems without affecting other frames. The power is also available to other IEEE 1394 devices that may be part of the interface network. The host adapter is capable of supplying 12V with a maximum current draw of 0.5 amps total to all three IEEE 1394 connectors.

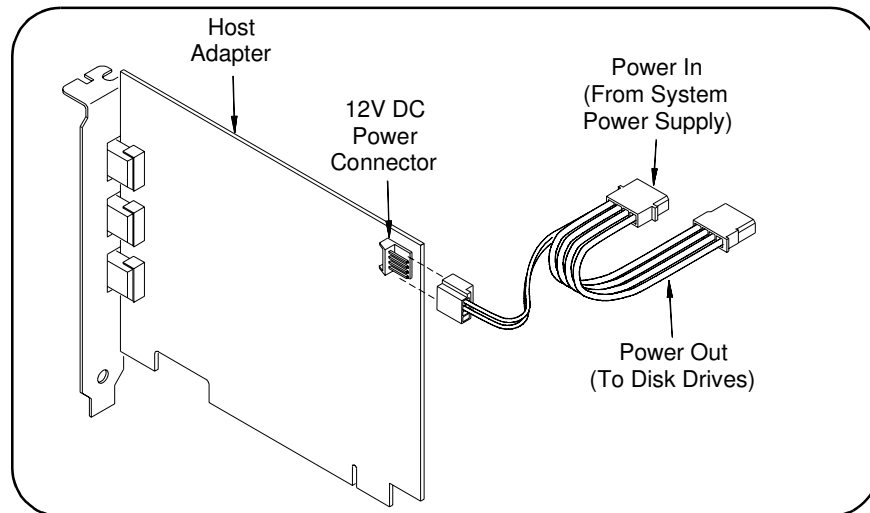

Figure 2-5. Connecting the Power Cable Between the PC and the Host Adapter.

7. Replace the computer cover. Connect one end of the interface cable to either adapter external connector.

Where to go Next

- **If you are installing the IEEE 1394 interface for the first time:**
Continue with “Step 2: Installing the HP E8491B Interconnect.”
- **If the E8491B and your VXI instruments are already installed:**
Proceed to “Step 4: Installing the HP I/O Libraries.” Note that the HP I/O Libraries contain the OHCI-compatible host adapter drivers.

Note

Refer to Chapter 4: IEEE 1394 Fundamentals and Interface Overview for more information on the OHCI-compatible PCI-to-IEEE 1394 host adapter.

Step 2: Installing the HP E8491B Interconnect

The HP E8491B interconnect links the IEEE 1394 bus to the backplane of the VXI mainframe. The HP E8491B is a C-size device with VXI Resource Manager and Slot 0 capability.

There are no configuration switches on the HP E8491B. The device’s logical address is 0 and it provides the system’s resource manager functionality via software that is part of the HP I/O Libraries. Its VXI servant area is 255, therefore; it is the interface to all VXI devices with logical addresses between 1 and 255. The HP E8491B is normally, **but not required to be**, installed in mainframe slot 0.

Note

Refer to “Alternate Configurations” on page 19 for information on using the HP E8491B with the HP E1406 Command Module and using it in VXI-MXI systems.

1. If power is applied to the VXI mainframe, remove power to the VXI mainframe and disconnect all power sources that may be applied to any instruments.
2. Insert the E8491B into mainframe slot 0 by aligning the module with the guides inside the mainframe (Figure 2-6). Slowly push the module into the slot until it seats in the backplane connectors. It may be necessary to pull out (not remove) the retaining screws in order to seat the device securely in the connectors.

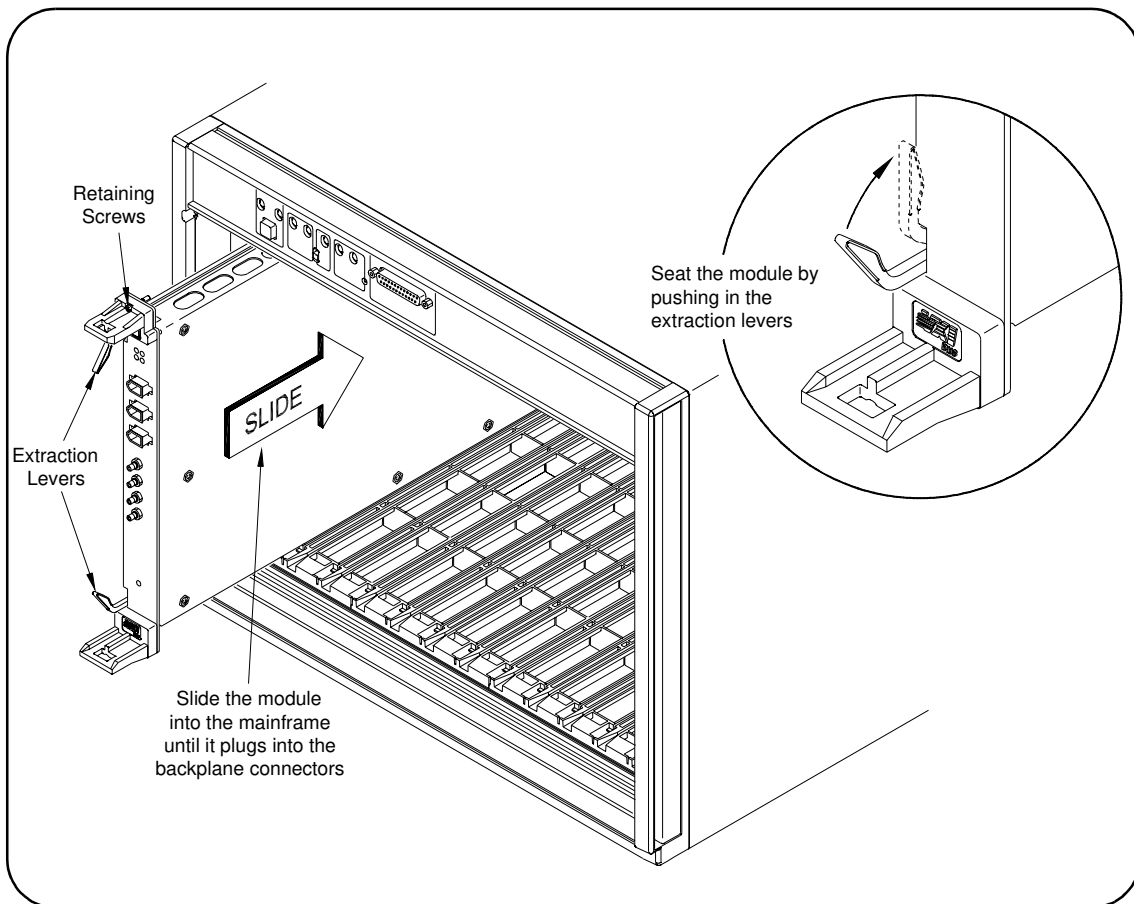

Figure 2-6. Installing the HP E8491B in the VXI Mainframe.

3. Tighten the retaining screws on the top and bottom of the module.

Connecting the HP E8491B to the Host Adapter

4. Connect the interface cable from the host adapter to E8491B port A, B, or C. The ports are identical and unused ports are available to connect additional E8491Bs and other IEEE 1394 devices in a daisy-chain or tree configuration (Figure 2-7). Notice that there can

be no closed loops.

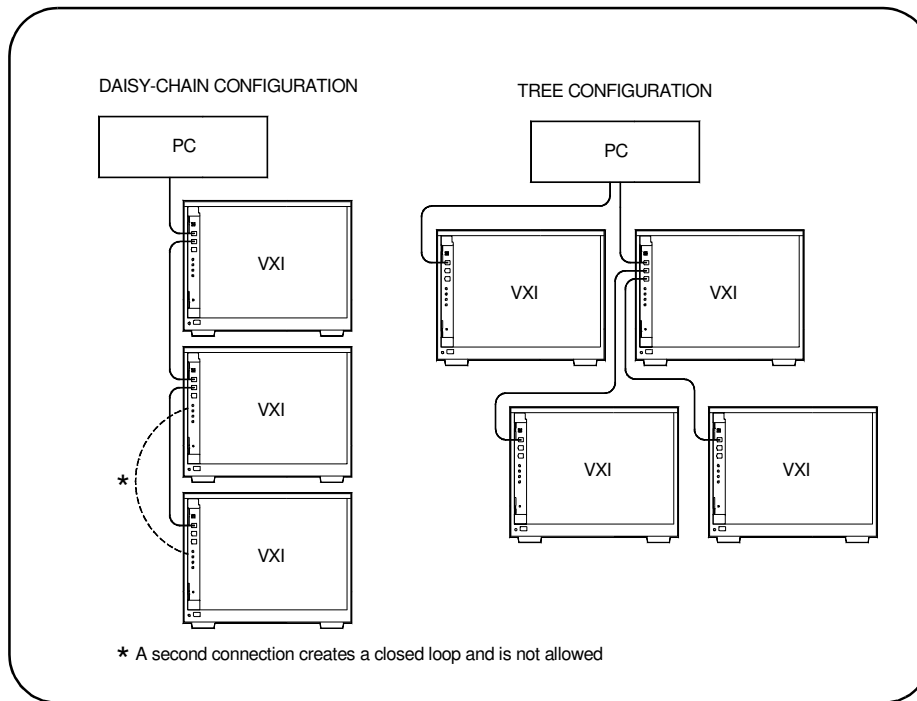

Figure 2-7. IEEE 1394 Interface Configurations.

I/O performance is impacted slightly by the hardware configuration. The VXI mainframe with the fewest number of hops (cable links) to the PC has the highest priority. However, each mainframe has equal access to the bus during each data transfer interval.

Note Refer to Chapter 4: IEEE 1394 Fundamentals and Interface Overview for information on the topology and terms associated with the IEEE 1394 bus.

Alternate Configurations

Certain applications may include the HP E1406A Command Module as an HP-IB interface to selected instruments. In this configuration, the E8491B must be the resource manager since its logical address is always 0. It is generally installed in mainframe slot 0 so that it also provides the system's slot 0 functionality.

If you want the E1406 to provide slot 0 functionality in addition to providing an HP-IB interface, set its configuration as follows:

1. Set the E1406 logical address to a value other than 0.
2. Set the Slot 0 and System Controller switches to "Enable" (default).
3. Set the CLK 10 source to "Internal" (default).
4. Set the VME BTO Disable switch to 0 - Enable (default). Set VME

Bus Timeout (BTO) on the E8491B to 'Off' (see "Editing the HP E8491B Configuration" later in this chapter).

5. Set the E1406 servant area to include the logical addresses of those instruments it is to control. Note:

E1406 servant area = (E1406 logical address + 1) through
(E1406 logical address + servant area switch setting)

6. Install the E1406 in slot 0.

If the E1406 is not the slot 0 device, its slot 0 functionality must be disabled. From step 2 above, set the E1406A Slot 0 and System Controller switches to "Disable". From step 4, set its VME BTO Disable switch 1 and ensure that VME Bus Timeout (BTO) on the E8491B is set to 'On'.

If you are using the E8491B in a configuration with multiple mainframes linked with VXI-MXI extender cards, the E8491B must be the resource manager; however, VME Bus Timeout (BTO) must be disabled (off - Step 4 above). Again, the E8491B is generally installed in mainframe slot 0 so that it also provides the system's slot 0 functionality. Refer to the MXI documentation for configuration guidelines based on where the E8491B is installed.

Where to go Next

- **If you are installing the IEEE 1394 interface for the first time:**
Continue with "Step 3: Installing VXI Instruments."
- **If your VXI instruments are already installed:**
Proceed to "Step 4: Installing the HP I/O Libraries."

Step 3: Installing VXI Instruments

Generally, any VXI instrument can be installed in any slot other than slot 0.

When installing instruments, notice that the E8491B and the IEEE 1394 bus do not extend the (VXI) backplane between frames in multi-frame VXI systems (MXI cards are required). This means that the multimeter and multiplexers in a VXI scanning multimeter for example, must be installed in the same mainframe (in adjacent slots). Devices sharing the VXI Local bus must also be installed in the same mainframe.

Installing C-size Instruments

Figure 2-8 shows the installation of C-size instruments.

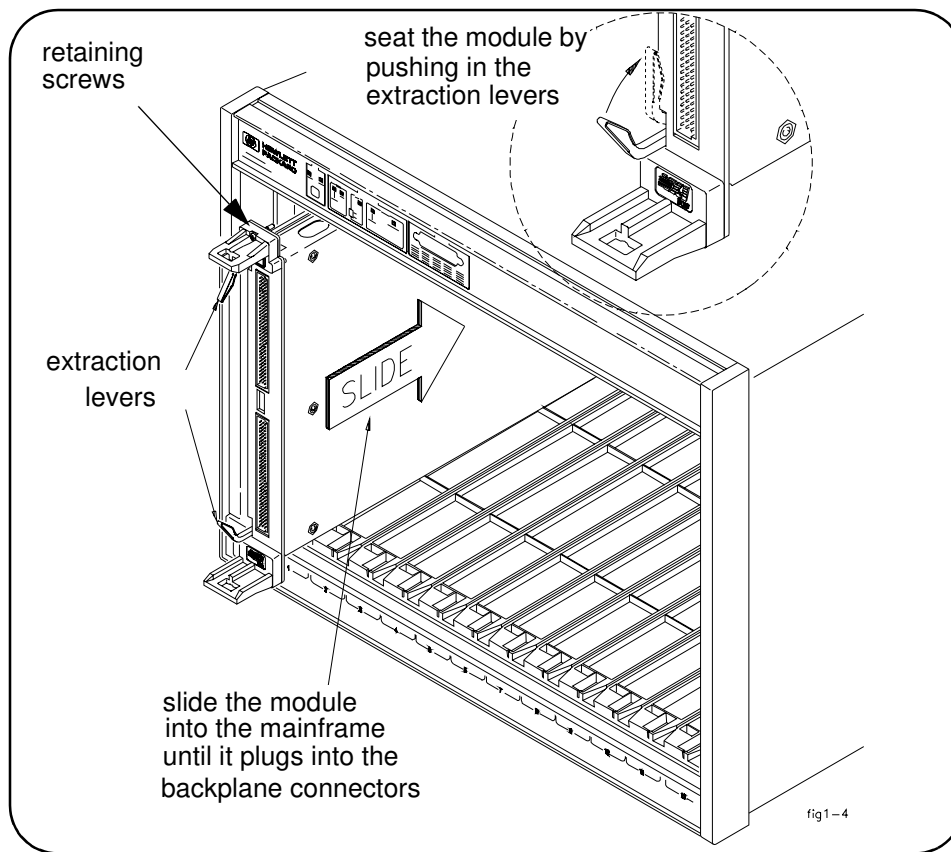

Figure 2-8. Installing C-size Instruments.

Caution To prevent damage to the VXI instruments being installed, remove power from the mainframe or set the power switch to Off or Standby before installing the instruments.

1. Insert the instrument into the mainframe by aligning the instrument with the card guides inside the mainframe. Slowly push the instrument into the slot until it seats in the backplane connectors. The front panel of the instrument should be even with the front edges of the mainframe.
2. Tighten the retaining screws on the top and bottom of the module.

WARNING All instruments within the VXI mainframe are grounded through the mainframe chassis. During installation, tighten the instruments' retaining screws to secure the instrument to the mainframe and to make the ground connection.

Installing A- and B-size Instruments

A- and B-size instruments can also be installed in the mainframe. These instruments are installed using a module carrier:

- **HP E1403C A/B-size Module Carrier** extends the P1 connector on the VXIbus backplane and mounts the (A/B-size) modules flush with C-size modules. This carrier is recommended for Hewlett-Packard B-size, slave-only devices which have the P1 connector.
- **HP E1407A A/B Module Carrier** extends the P1 and P2 connectors on the VXIbus backplane. This carrier is recommended for B-size, slave-only devices which have the P1/P2 connectors.

Caution To prevent damage to the VXI instruments, install the instruments when the mainframe is turned off.

Figure 2-9 shows the installation of a B-size instrument using a module carrier. The procedure is described in the following three steps.

1. Install the HP E1403 or E1407 A/B-size Module Carrier into the mainframe. This is done by aligning the top and bottom of the carrier with the card guides and slowly pushing the carrier into the mainframe. The front of the carrier should be even with the front edges of the mainframe.
2. Slide the A- or B-size instrument into the carrier until it connects.
3. Tighten the retaining screws on the top and bottom of the instrument.

WARNING All instruments within the VXI mainframe are grounded through the mainframe chassis. During installation, tighten the instruments' retaining screws to secure the instrument to the mainframe and to make the ground connection.

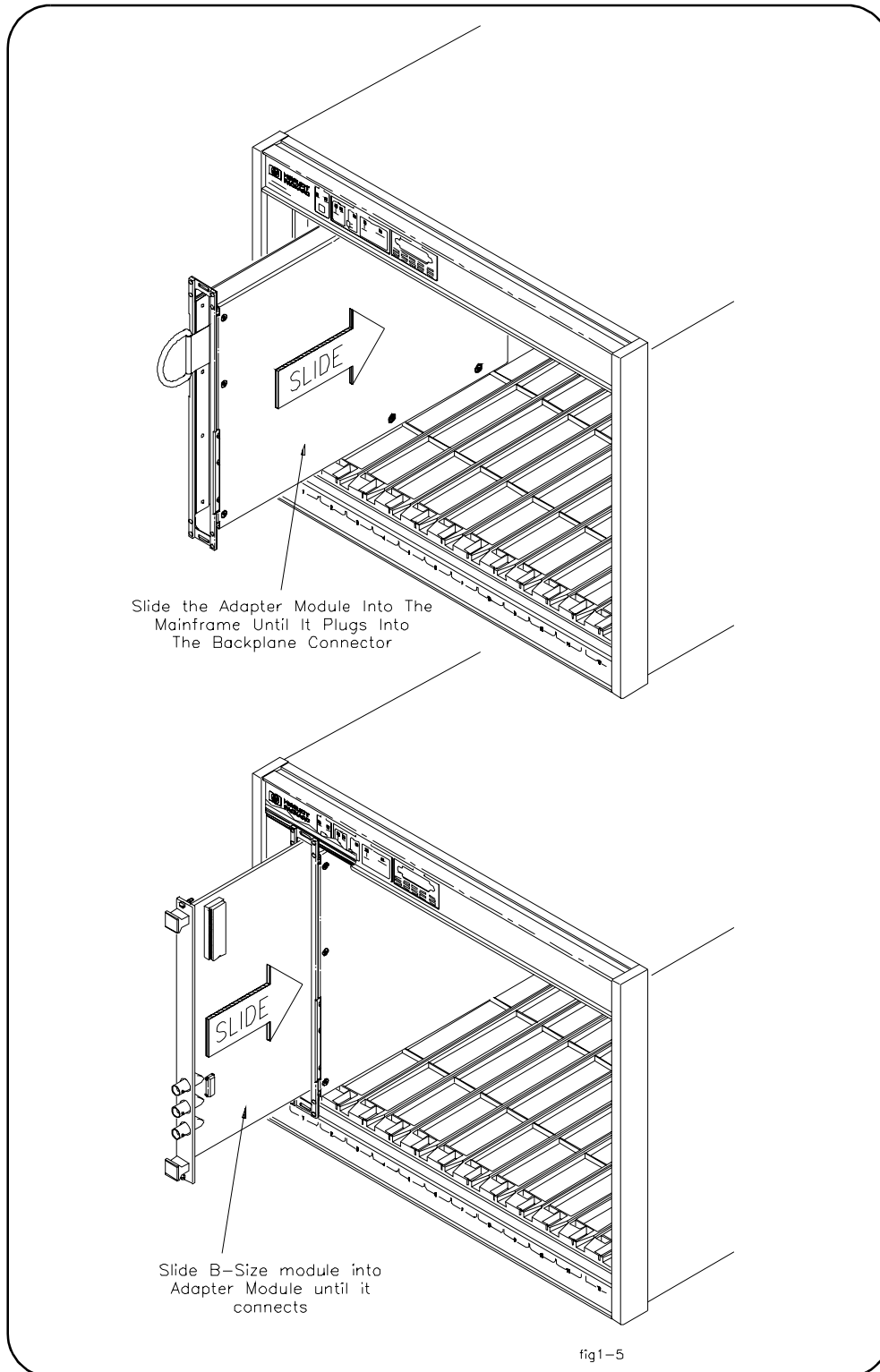

Figure 2-9. Installing A- and B-size VXI Instruments.

Step 4: Installing the HP I/O Libraries

The HP I/O Libraries CD contains the software required to use the IEEE 1394 interface in a VXI system. It also includes the OHCI-compatible host adapter drivers.

Note Refer to Chapter 4: IEEE 1394 Fundamentals and Interface Overview for more information on the HP I/O Libraries and related software.

Note If your PC indicates that new hardware has been found after applying power, do the following:

- Select “Driver from disk provided by hardware manufacturer”-Press OK.
- Insert the I/O Libraries CD in your CD ROM drive.
- Point or browse to the drive letter for the CD ROM. Press OK.
- You will be instructed to install the driver that matches the hardware. Begin by performing the following steps.

1. Apply power to your PC. Close all open applications and insert the I/O Libraries CD into your PC CD-ROM drive. Inserting the CD automatically activates the installer. If the installer does not activate, select Start / Run and type <drive>:SETUP.EXE where <drive> designates the CD drive. Do not apply power to the VXI mainframe.
2. Review the information and license agreements presented at the beginning of the installation process.
3. Continue through the installation process as directed by the installer. Be sure to indicate that you want HP I/O Libraries support for the E8491B interface installed by clicking on the box next to “Install HP E8491 VXI Components.”
4. Read the Readme.txt file if you choose then select “**Do not configure the interfaces at this time**” in the next window.
5. After the installation is complete, re-start the computer.

Configuring the HP E8491B Interconnect

1. Connect the IEEE 1394 interface cable between the host adapter (PC) and one of the IEEE 1394 ports on the E8491B front panel.
2. Turn on the VXI mainframe.
3. From the HP I/O Libraries program group created when the libraries were installed (Start >> Programs >> HP I_O Libraries), click on ‘I_O Config’ (Figure 2-10).

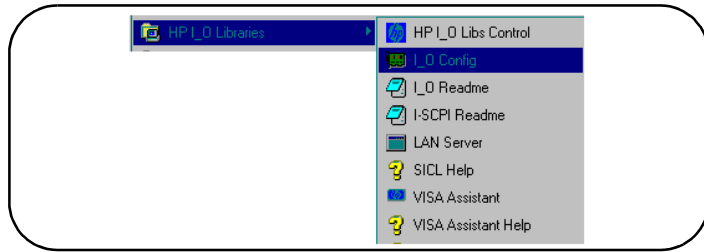

Figure 2-10. The HP I/O Libraries Program Group.

An alternative is to click on the HP icon in the lower right-hand corner of your monitor which is placed there following the installation of the I/O Libraries and configuring the HP E8491B. Clicking on the HP icon brings up a pop-up menu like that shown in Figure 2-13. Click on “Run I/O Config”. Either method described in this step brings up a configuration window similar to Figure 2-11.

4. Select HP E8491 in the “Available Interface Types” box and click the ‘Configure’ button.

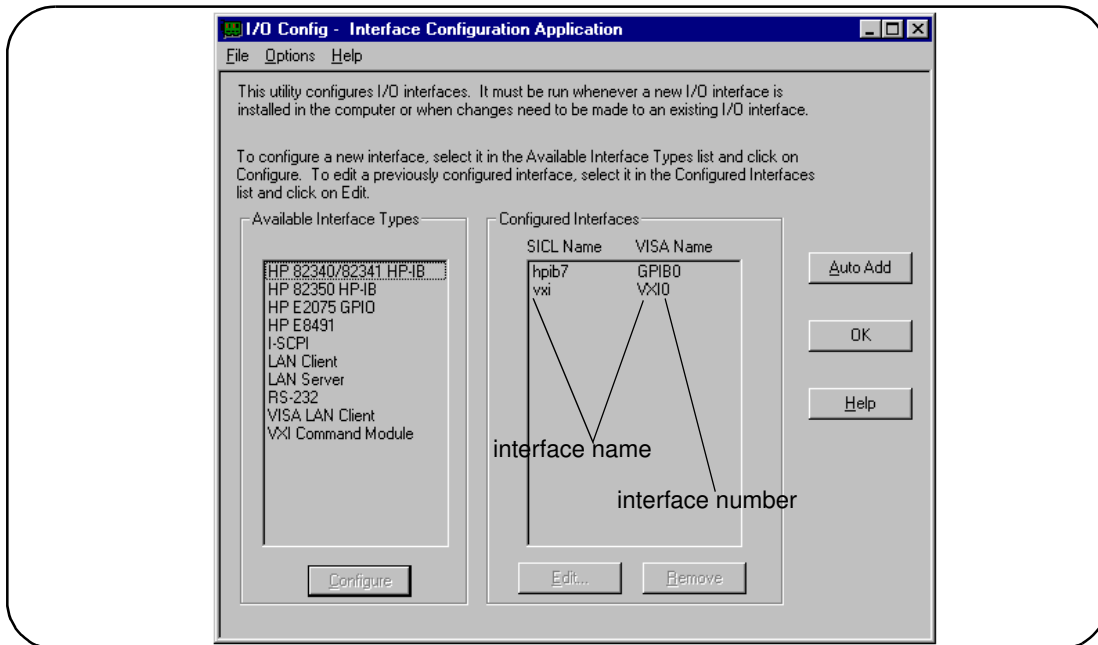

Figure 2-11. The HP I/O Libraries I/O Config Utility.

The HP E8491B uses the SICL interface name ‘vxi’ and the VISA interface name ‘VXI’ (Figure 2-12). The VISA interface number is assigned by the ‘I/O Config’ utility and is unique to each E8491B. The interface name and number identify each mainframe in multi-frame VXI systems, and are also used in addressing each instrument in the mainframe. The unique interface number allows instruments with the same logical addresses to be installed in different mainframes, but in the same system.

The “Locate” button on the “HP E8491 VXI Board Configuration” screen can be used to help you identify and keep track of all the mainframes in a multi-mainframe system.

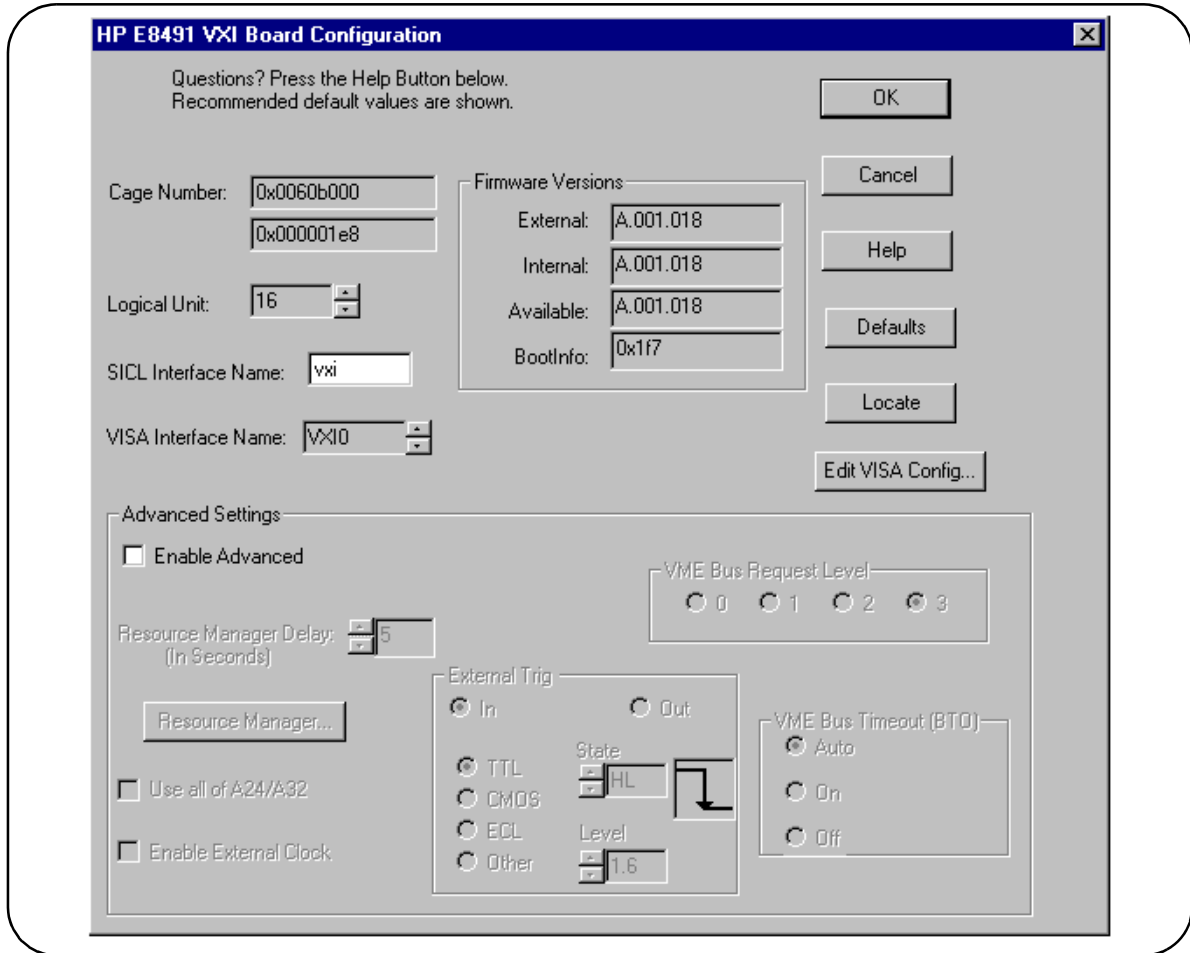

Figure 2-12. Editing the HP E8491B Configuration.

5. Figure 2-11 returns with the SICL Name and VISA Name inserted. Click OK to close the utility and complete the configuration.

Editing the HP E8491B Configuration

When it is necessary to edit your configuration, click ‘I_O Config’ in the HP I/O Libraries program group (Figure 2-10). To edit the HP E8491B, click (highlight) the configured interface (“vxi VXI0”) in the utility (Figure 2-11). This activates the ‘Edit’ and ‘Remove’ buttons at the bottom of the window.

If you want to change the SICL interface name and number to something more descriptive, use the ‘SICL Interface Name’ field. You can change the VISA interface number using the up/down arrows next to the ‘VISA Interface Name’ field. The SICL and VISA interface names (and numbers) do not have to be the same.

Make a note of the interface name and number, as they are used in addressing instruments in the mainframe (see “Chapter 3: VXI Programming Using the IEEE 1394 Serial Bus” for more information).

The ‘Help’ button provides information on each item in the window.

Editing the HP E8491B Configuration on Windows 95 Platforms

After installing the HP I/O Libraries and configuring the HP E8491B on the Windows 95 platform, an **hp** icon is placed in the bottom right corner of your PC monitor (Figure 2-13).

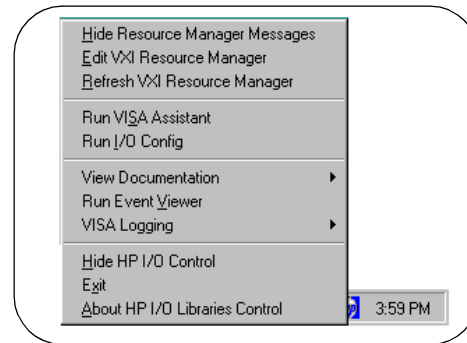

Figure 2-13. Editing Your Configuration on Windows 95 Platforms.

Clicking on the icon brings up the following menu items:

Hide Resource Manager Messages

Enable/disable displaying resource manager messages during mainframe power-on or during a E8491B reset.

Edit VXI Resource Manager

Allows you to edit the Resource Manager configuration files and/or to run the Resource Manager.

Refresh VXI Resource Manager

Resets and runs the Resource Manger on all VXI mainframes in your system. You must “refresh” (re-run) the resource manager each time changes are made to its configuration. NOTE: The resource manager will run automatically whenever the mainframe is powered on.

Run VISA Assistant

Activates the HP VISA Assistant utility. This utility displays all devices connected to the interface and their VISA interface address. It provides other information on drivers, formatted I/O, memory and other attributes. Formatted I/O allows you to send a SCPI command to a device to confirm communication with the device or simply to set a command parameter or to query a device state.

Run I/O Config

Runs the I/O Config utility and brings up the “I/O Config - Interface Configuration Application” window shown in figure 2-11.

View Documentation

Selects the Readme.txt, the VISA Help file or the SICL Help file for viewing.

Run Event Viewer

Brings up the event viewer for viewing the Applications Log for your PC.

VISA Logging

Enables/disables the VISA logging, runs the event viewer or the debug window.

Hide HP I/O Control

Removes the HP icon in the lower right-hand corner of your Windows 95/NT window task bar. To re-install the icon, go to the START button >> Programs >> HP I_O Libraries and click on HP I_O Libs Control.

Exit

Terminates the HP I/O Libraries Control.

Note For HP E8491 Controllers to work, the HP I/O Libraries Control must be running. Executing “Exit” will disable HP E8491B operation.

About HP I/O Libraries Control

Provides the HP I/O Libraries Control version number.

Step 5: Installing HP VXIplug&play Instrument Drivers

There are no SCPI instrument drivers installed in, or downloaded to, the HP E8491B. While this does not impact message-based instruments, register-based instruments in IEEE 1394 based systems are usually programmed using their *VXIplug&play* drivers.

The HP VXIplug&play drivers are located on the HP Universal Instrument Drivers CD which ships with the E8491B and with each VXI instrument. The installer program on the driver CD is similar to that on the I/O libraries CD.

Once the drivers have been installed, reboot the PC.

Note If you are updating an existing VXI system to use the HP E8491B and IEEE 1394 serial bus, we highly recommend that you obtain the latest version of the HP *VXIplug&play* drivers. Information on the latest drivers available can be found on the World Wide Web at http://www.hp.com/go/inst_drivers .

Step 6. Verifying the Installation

Once you have installed the hardware, the I/O Libraries, the *VXIplug&play* drivers, and have re-booted the PC, you should now verify the installation. This ensures that you can communicate with instruments in the system over the IEEE 1394 interface. Two ways to check your system are to run an instrument's soft front panel, or to view the output of the system's resource manager.

Using Instrument Soft Front Panels

Soft front panels are part of the instruments' *VXIplug&play* drivers. A soft front panel is activated from the 'Vxipnp' program group as shown in Figure 2-14.

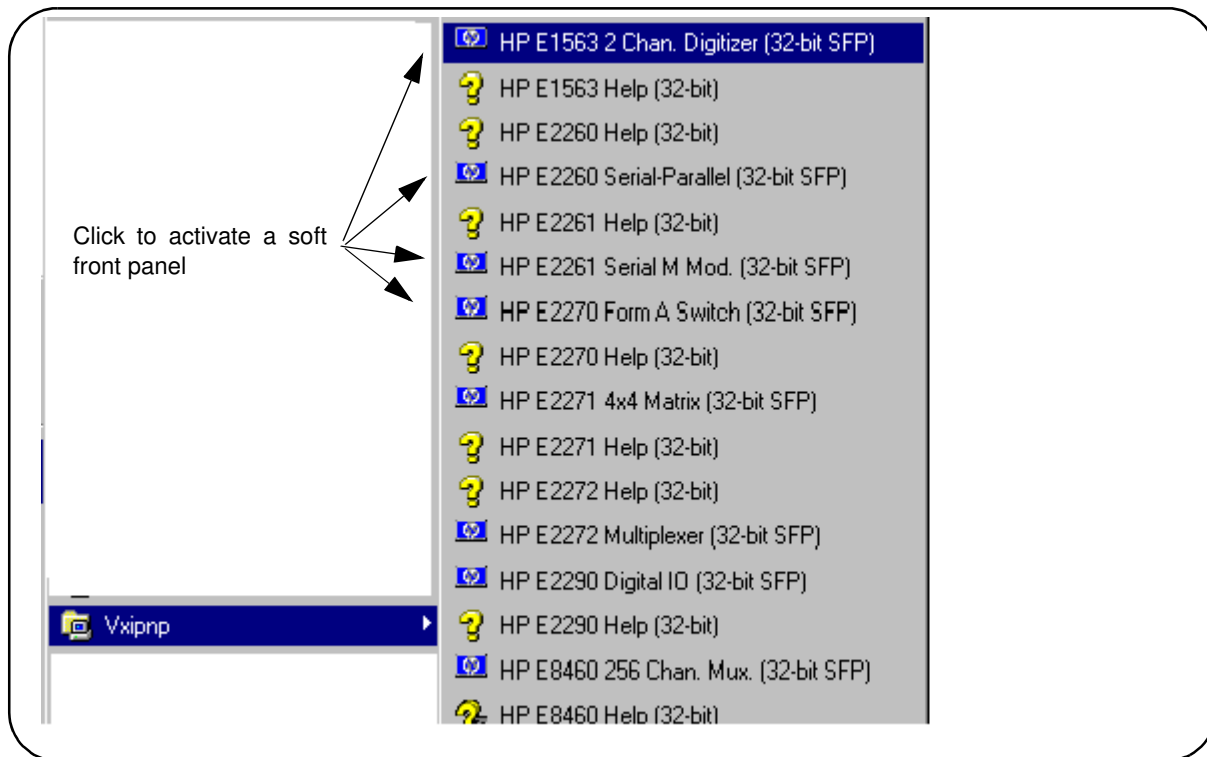

Figure 2-14. Selecting a *VXIplug&play* Soft Front Panel.

When the system hardware and software are properly installed and the PC is communicating with the mainframe, the soft front panel will be opened and a connection made to the instrument as shown in Figure 2-15.

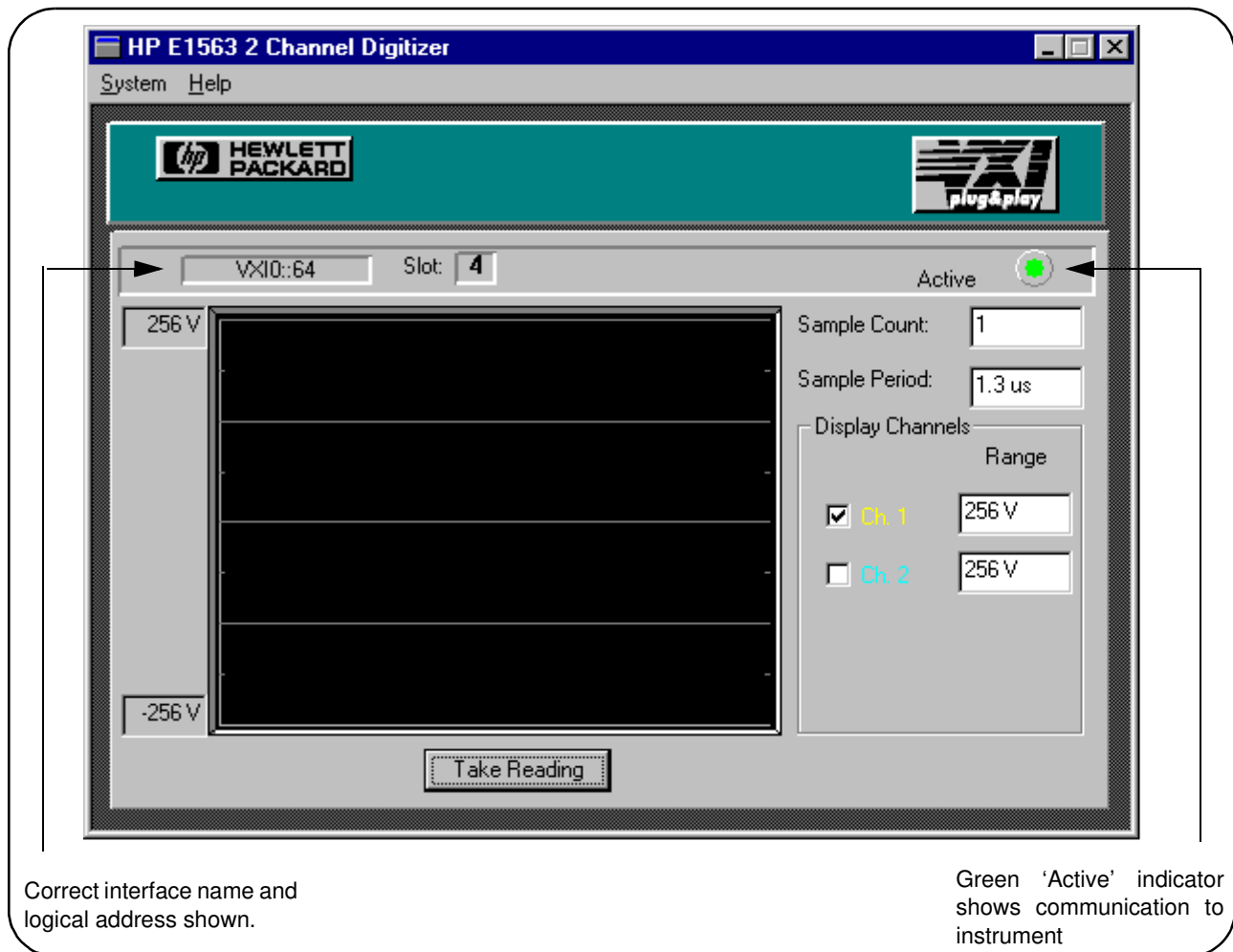

Figure 2-15. Soft Front Panel Indicating PC - Mainframe Communication.

Viewing the Resource Manager Output

Another way to determine if your system is properly configured is to view the output of the resource manager. The easiest way to view the output is using the I/O Libraries' 'I/O Config' utility.

1. Press the HP I/O Libraries Control icon in the lower right-hand side of your monitor and select "Edit VXI Resource Manager". In the Resource Manager pop-up window, select "RM Output". The resource manager output will show the "VXI Current Configuration" with all devices it can communicate with listed in the "VXI Device Table".
2. Click on Start >> Programs >> I_O Config to bring up the I/O Config window (Figure 2-11).
 - 2a. Select the "Configured Interfaces" name corresponding to the E8491B to bring up the HP E8491 VXI Board Configuration window (Figure 2-12).

2b. Perform steps 1, 2 and 3 in Figure 2-16.

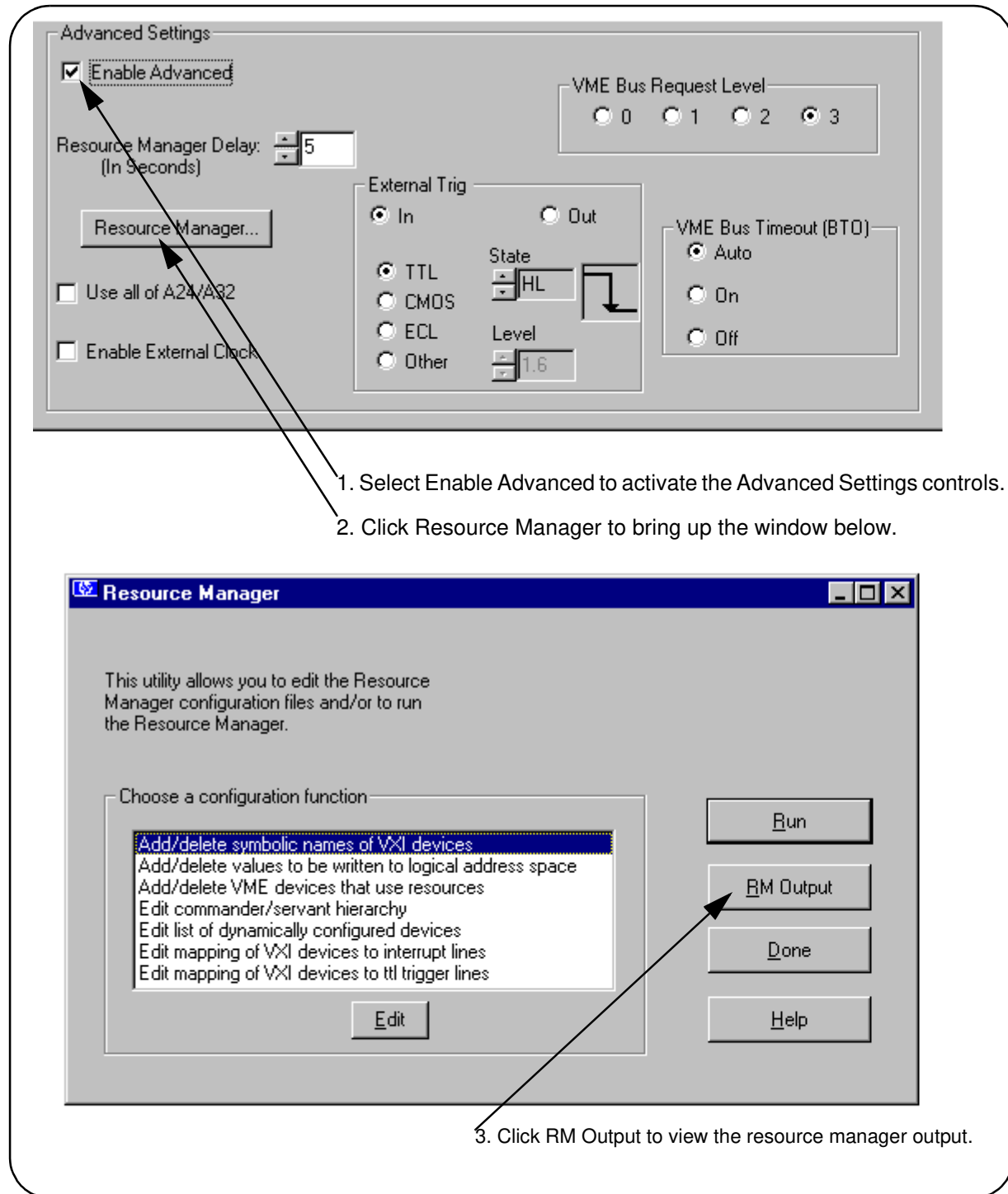

Figure 2-16. Viewing the Resource Manager Output using 'I/O Config'.

Figure 2-17 is a partial listing of a typical resource manager output.

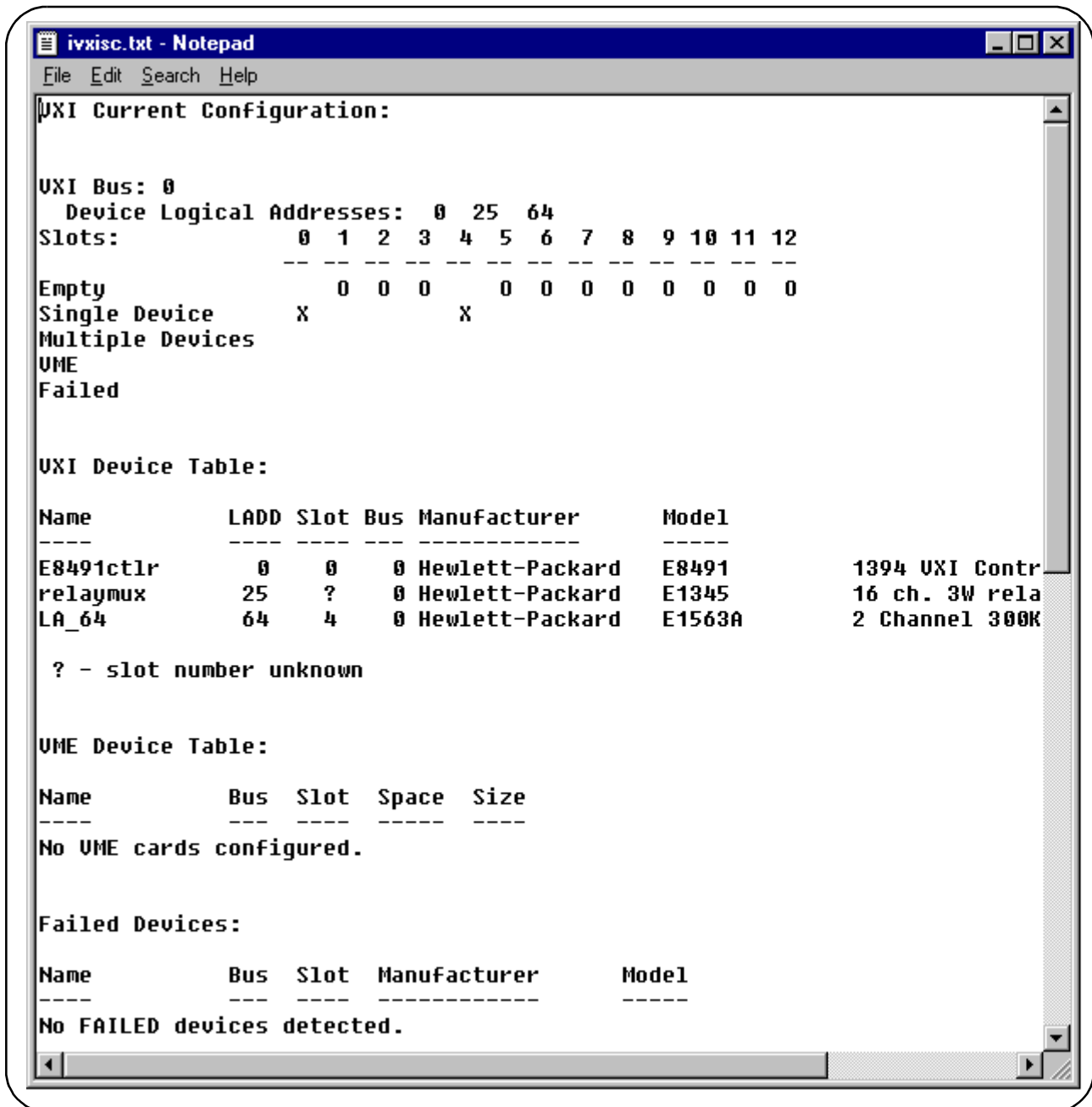

Figure 2-17. Typical Resource Manager Output (partial listing).

Troubleshooting Installation Problems

The following list of troubleshooting items may help you get your HP E8491B interface working properly if you have encountered problems verifying installation.

1. It is very important that you upgrade the PC BIOS to the latest version your PC manufacturer provides whether your PC is new or old. Many early versions of the PCI BIOS contained bugs. Upgrading to the latest version of BIOS will eliminate those bugs upgraded by the new BIOS. A BIOS upgrade and a video driver upgrade may be required to fix PCI-related problems even on a new PC.
2. Make sure the PCI BIOS is correctly configured. New PC's have a BIOS flag that usually reads "Plug&Play OS" or "Running Windows 95". This *must* be set appropriately for the OS you are using; Win 95 is a plug&play OS whereas, Win NT is not.
3. The HP E8491B requires installation of the PCI-to-IEEE 1394 host adapter card in a bus-mastering PCI slot. Consult your PC's user manual to determine which slots are bus-mastering (it is possible that all slots are bus-mastering).
4. In addition to the above, you may need to move the HP E8491B to a separate IRQ line in the PC. PCI allows up to four devices sharing an IRQ line. However, due to bugs in some cards, this doesn't always work and you may need to have one IRQ per card. Moving the IRQ is not easy and whether it can be done will depend on which operating system you are using and on the details of the BIOS implementation of your PC.

Running the Resource Manager

The I/O Libraries Control utility must be running to enable the resource manager to run. The resource manager initializes and prepares the VXI system for use. The I/O Libraries Control utility is installed when the E8491B interface is configured using 'I/O Config'. It can be accessed by clicking on the HP logo in the lower right hand corner of your Windows panel. The resource manager will run when:

- mainframe power is applied or cycled
- the E8491B faceplate "Reset" button is pressed
- activated from the 'I/O Config' utility
- activated from the 'I/O Control' icon (see Figure 2-13)

In VXI systems with multiple E8491Bs (mainframes), individual mainframes can be turned off without affecting other mainframes in the system. When a mainframe is turned on, the resource manager reconfigures the mainframe.

Note The resource manager will only run if the I/O Libraries Control utility is started.

Chapter 3

VXI Programming Using the IEEE 1394 Serial Bus

Using this Chapter

This chapter contains examples and general information for programming VXI systems over the IEEE 1394 serial bus. The contents of the chapter include:

- Programming Register-Based and Message-Based Instruments 35
- Opening Instrument Sessions 35
- Optimizing Programs 36
- HP E8491B Triggering 43
- Using HP E8491B Shared Memory 47

Programming Register-Based and Message-Based VXI Instruments

There are no SCPI instrument drivers for register-based instruments installed in, or downloaded to, the HP E8491B. Therefore, register-based instruments are programmed over the IEEE 1394 bus using either their *VXIplug&play* drivers, or through register-level peeks and pokes using HP VISA or SICL.

Message-based instruments are programmed using HP *VXIplug&play* drivers, or using SCPI commands embedded in HP VISA or SICL function calls.

VXIplug&play drivers for HP register-based and message-based instruments are contained on the HP Universal Instrument Drivers CD which ships with each HP VXI instrument.

Opening Instrument Sessions

Programs which run over the IEEE 1394 interface begin by opening a session between the VXI instrument and the driver or I/O library (VISA or SICL). An address that includes the interface name and number (described in Chapter 2) and the instrument's logical address is used in opening these sessions.

Following are three segments that open sessions to an E1563A Digitizer in HP *VXIplug&play*, HP VISA, and SICL programs.

HP *VXIplug&play*

```
ViSession vi;  
  
// open device (VXIplug&play) session to the HP E1563  
errStatus = hpe1563_init("VXI0::24::INSTR", VI_FALSE,  
VI_FALSE, &vi);
```

HP VISA

```
ViSession defaultRM, id;

//open device (VISA) session to the HP E1563
viOpenDefaultRM (&defaultRM);

viOpen (defaultRM, "VXI0::24::INSTR", VI_NULL, VI_NULL,
&id);
```

SICL

```
INST id;

// open device (SICL) session to the HP E1563
id = iopen("vxi,24")
```

Or, to open an interface session to the HP E8491B:

```
INST id;

// open (SICL) session to the VXI interface
id = iopen("vxi")
```

The HP E8491B IEEE 1394 interconnect uses the VISA interface name VXI<n> or SICL interface name vxi. The interface number is assigned using the 'I/O Config' utility (see Chapter 2). In the examples above, the logical address of the HP E1563 digitizer is 24 and INSTR indicates a VISA instrument control resource.

Optimizing Programs

Programs that run over the IEEE 1394 serial bus are optimized by transferring data between the PC and the instrument in blocks. The following section identifies HP VISA and SICL functions that perform block transfers.

Note Refer to "Chapter 4: IEEE 1394 Fundamentals and Interface Overview" for detailed information on data transfers using the IEEE 1394 data transfer protocol.

Block Data Transfers

VXI*plug&play* drivers for selected instruments contain functions that perform block transfers. You will need to consult the driver help file to determine if the driver for a particular instrument supports block transfers.

The following HP VISA functions perform block transfers over the IEEE 1394 serial bus:

viMoveIn8	viMoveOut8	viMove
viMoveIn16	viMoveOut16	viMoveAsync
viMoveIn32	viMoveOut32	

The following extended SICL function is unique to the HP E8491B (must be used on the E8491B) and is used for block transfers over the bus:

iblockmovex

Additionally, the extended SICL functions shown below must be used when porting SICL programs to the IEEE 1394 bus from other I/O interfaces:

imapx
iunmapx
ipeekx8, ipeekx16, ipeekx32
ipokex8, ipokex16, ipokex32

These functions are covered in detail in the SICL documentation.

The following examples demonstrate how to set up and perform block transfers using HP *VXIplug&play* and HP VISA functions.

Block Transfers using HP VXIplug&play Drivers

This program performs a block transfer of 2,000 readings using the HP E1563A digitizer and its *VXIplug&play* driver.

```
// 1563VPNP.CPP - This program transfers a block of 2,000 readings from the
// HP E1563 digitizer to the computer using the VXIplug&play driver's
// hpe1563_fetchAll_Q function. 2,000 readings is the maximum number of
// readings that can be transferred using the function.

#include "hpe1563.h"// include the driver header file
#include <stdio.h>
#include <stdlib.h>
#include <windows.h>

// project files: 1563vpnp.cpp, hpe1563.lib

// Specify the addressing path.
#define E1563 "VXI0::64::INSTR" // VXI addressing

// prototypes
void check(ViSession vi, ViStatus error);

void main(void)
{
    ViSession vi;
    ViStatus errStatus;
    ViInt16 rdgs[2000];
    ViInt16 *dataPtr;// pointer to cast readings to 16-bit integers
    ViReal64 range;// range variable for reading conversions
    int i;
    long dataArrayLen=2000;// return 2,000 readings using
                          // hpe1563_fetchAll_Q
    ViInt32 numRdgs;
    ViChar err_message[256];

    dataPtr = rdgs;// set pointer to rdgs array
```

```

// open a VXIplug&play device session and reset the digitizer
errStatus = hpe1563_init(E1563,0,1,&vi);
if( VI_SUCCESS > errStatus)
{
    hpe1563_error_message( vi, errStatus, err_message);
    printf("Unable to open %s\n", E1563);
    printf("hpe1563_init() returned error message %s\n", err_message);
    return;
}

// enable digitizer error detection
hpe1563_errorQueryDetect(vi, 1);

    // set a 5s timeout period to allow functions to complete
errStatus = hpe1563_timeOut(vi, 5000);
check(vi, errStatus);

// configure the digitizer to take 2,000 post-trigger readings
// not to exceed 4V on channel 1
errStatus=hpe1563_configure(vi, 1, 4.0, 2000,1);
check(vi, errStatus);

    // set an immediate trigger
errStatus = hpe1563_trigEvent(vi, 1, hpe1563_TRIG_IMM, 0.0);
check(vi, errStatus);

    // set the minimum sample period
errStatus = hpe1563_sampTim(vi, hpe1563_SAMP_TIM_MIN);
check(vi, errStatus);

// disable digitizer error detection
hpe1563_errorQueryDetect(vi, 0);

    // initiate the digitizer
errStatus = hpe1563_initImm(vi);

// pause 3 ms (1.3e-6 * 2000) to allow readings to complete
Sleep (3);

// fetch readings from the digitizer's A24 space
errStatus = hpe1563_fetchAll_Q(vi, dataArrayLen, (ViInt32 *)rdgs,
&numRdgs );

// confirm readings transferred are valid by printing first 5 readings
dataPtr = (ViInt16 *)rdgs;

// query digitizer reading range
errStatus = hpe1563_range_Q(vi, 1, &range);
printf("Reading samples are:\n\n");

    for (i=0; i<10; i+=2)
    {
        printf("%lf\n\n",dataPtr[i]*range/32768);
    }

```

```

// reset digitizer following the transfer
errStatus = hpe1563_reset(vi);

// close the device session
hpe1563_close(vi); // HP VXIplug&play session
}

//*****

// error checking routine

void check (ViSession vi, ViStatus errStatus)
{
    ViInt32 inst_err;
    ViChar err_message[256];

    if(VI_SUCCESS > errStatus)
    {
        if(hpe1563_INSTR_ERROR_DETECTED == errStatus)
        {
            /* query instrument error */
            hpe1563_dcl(vi); /* send a device clear */
            hpe1563_error_query(vi, &inst_err, err_message);
            /* display the error */
            printf("Instrument Error : %ld, %s\n", inst_err, err_message);
        }
        else
        {
            /* get driver error message */
            hpe1563_error_message(vi, errStatus, err_message);
            /* display the error */
            printf("HP E1563 Driver Error : %ld, %s\n", errStatus, err_message);
        }

        hpe1563_reset(vi); /* reset the digitizer */
        hpe1563_close(vi); /* close the digitizer handle */

        exit(1);
    }

    return;
}

```

Comments

1. The maximum block transfer size allowed by the HP E1563A **hpe1563_fetchAll_Q** function is 2,000 bytes.
2. This manual is included on the HP I_O Libraries CD. By viewing the manual from the CD, you can cut and paste this program into your development environment.
3. The section “Using HP E8491B Shared Memory” contains an example of block data transfers using HP SICL.

Block Transfers using HP VISA This program performs a block transfer of 60,000 readings using the HP E1563A digitizer and the HP VISA function **viMoveIn32**.

```
// 1563visa.CPP - This program configures the HP E1563A digitizer using its
// VXIplug&play driver and then transfers a block of 60,000 readings from
// the digitizer's FIFO memory to the computer using the VISA viMoveIn32
// function.

#include "hpe1563.h"// include the driver header file
#include "visa.h"
#include <stdio.h>
#include <stdlib.h>
#include <windows.h>

// project files: 1563visa.cpp, hpe1563.lib, VISA.lib

// specify the addressing path
#define E1563 "VXI0::64::INSTR" // VXI addressing

// prototypes
void check(ViSession vi, ViStatus error);
void err_handler(ViSession vi, ViStatus err);

void main(void)
{
    ViSession vi;
    ViStatus errStatus, err;
    ViInt32 rdgs[60000];
    ViReal64 range;// range variable for reading conversions
    ViInt16 *dataPtr;// pointer to cast readings to 16-bit integers
    int i;
    ViChar err_message[256];

    // open a VXIplug&play device session and reset the digitizer
    errStatus = hpe1563_init(E1563,0,1,&vi);
    if( VI_SUCCESS > errStatus)
    {
        hpe1563_error_message( vi, errStatus, err_message);
        printf("Unable to open %s\n", E1563);
        printf("hpe1563_init() returned error message %s\n", err_message);
        return;
    }

    // enable digitizer error detection
    hpe1563_errorQueryDetect(vi, 1);

    // set a 5s timeout period to allow functions to complete
    errStatus = hpe1563_timeOut(vi, 5000);
    check(vi, errStatus);

    // configure the digitizer to take 60,000 post-trigger readings
    // not to exceed 4V on channel 1
    errStatus=hpe1563_configure(vi, 1, 4.0, 60000, 1);
    check(vi, errStatus);
}
```



```

// set an immediate trigger
errStatus = hpe1563_trigEvent(vi, 1, hpe1563_TRIG_IMM, 0.0);
check(vi, errStatus);

// set the minimum sample period
errStatus = hpe1563_sampTim(vi, hpe1563_SAMP_TIM_MIN);
check(vi, errStatus);

// disable digitizer error detection
hpe1563_errorQueryDetect(vi, 0);

// initiate the digitizer
errStatus = hpe1563_initImm(vi);

// pause 78 ms (1.3e-6 * 60000) to allow readings to complete
Sleep (78);

// transfer the (60,000) readings from the digitizer using the VISA
// function viMoveIn32 - use the same session name (vi) opened for
// VXIplug&play
err = viMoveIn32(vi, VI_A16_SPACE, 0x08, 60000, (ViPUInt32)rdgs);
if(err < VI_SUCCESS) err_handler(vi, err);

// confirm readings transferred are valid
dataPtr = (ViInt16 *)rdgs;

// query digitizer reading range
errStatus = hpe1563_range_Q(vi, 1, &range);
printf("Reading samples are:\n\n");

    for (i=0; i<10; i+=2)
    {
        printf("%lf\n\n",dataPtr[i]*range/32768);
    }

// reset digitizer following the transfer
errStatus = hpe1563_reset(vi);

// close the device session
hpe1563_close(vi); // HP VXIplug&play session
}

//*****
// error checking routine

void check (ViSession vi, ViStatus errStatus)
{
    ViInt32 inst_err;
    ViChar err_message[256];

    if(VI_SUCCESS > errStatus)
    {
        if(hpe1563_INSTR_ERROR_DETECTED == errStatus)
        {

```

```

    /* query instrument error */
    hpe1563_dcl(vi); /* send a device clear */
    hpe1563_error_query(vi, &inst_err, err_message);
    /* display the error */
    printf("Instrument Error : %ld, %s\n", inst_err, err_message);
}
else
{
    /* get driver error message */
    hpe1563_error_message(vi, errStatus, err_message);
    /* display the error */
    printf("HP E1563 Driver Error : %ld, %s\n", errStatus, err_message);
}

hpe1563_reset(vi); /* reset the digitizer */
hpe1563_close(vi); /* close the digitizer handle */

exit(1);
}

return;
}

//*****

// Error handling function

void err_handler (ViSession vi, ViStatus err)
{
    char buf[1024]={0};
    viStatusDesc(vi, err, buf);
    printf("ERROR = %s\n", buf);
    return;
}

```

Comments

1. A single instrument session opened with the hpe1563_init function can be used by both HP VXI*plug&play* driver function calls and by HP VISA function (i.e **viMoveIn32**) calls.
2. This manual is included on the HP I_O Libraries CD. By viewing the manual from the CD, you can cut and paste this program into your development environment.
3. The section “Using HP E8491B Shared Memory” contains an example of block data transfers using HP SICL.

HP E8491B Triggering

The HP E8491B is capable of asserting, receiving, and routing trigger signals along the VXI (mainframe) backplane trigger lines. In addition to the VXI backplane's eight TTL level trigger lines and two ECL level trigger lines, the E8491B can receive and assert triggers on the faceplate 'Trig In' and 'Trig Out' connectors.

Table 3-1 summarizes the triggering parameters and capabilities of the HP E8491B.

Table 3-1. HP E8491B Triggering Parameters.

Trigger Lines	Trigger Levels	Trigger Routing
TTLTRG7 - TTLTRG0 (VXI backplane)	Trigger levels or pulses can be output on any number of TTLTRG trigger lines.	One TTLTRG trigger line can be routed to one ECLTRG trigger line.
ECLTRG1 - ECLTRG0 (VXI backplane)	Trigger levels or pulses can be output on any number of ECLTRG trigger lines.	One ECLTRG trigger line can be routed to one TTLTRG trigger line.
Trig In Port* (HP E8491B faceplate)	Input trigger levels are TTL, ECL, CMOS, or programmable up to +30V. Default assumes TTL low true signal.	Input triggers can be routed to any number of TTLTRG trigger lines and to any number of ECLTRG trigger lines.
Trig Out Port* (HP E8491B faceplate)	Output trigger level is +5V (low true - default) and can be pulled to +30V.	One TTLTRG or ECLTRG trigger line can be routed to the Trig Out port

* The E8491B Trig In and Trig Out ports are configured using the HP I/O Libraries 'I/O Config' utility.

Using Triggers

The triggering functionality of the HP E8491B is accessed through the following HP VISA and SICL functions:

Asserting Triggers - HP VISA

viSetAttribute

VI_ATTR_TRIG_ID

VI_TRIG_TTL0 to VI_TRIG_TTL7

VI_TRIG_ECL0 to VI_TRIG_ECL1

viAssertTrigger

VI_TRIG_PROT_DEFAULT

Asserting Triggers - HP SICL

```
ivxitriggeroff
ivxitriggeron
ixtrigger
  I_TRIG_ALL
  I_TRIG_TTL0 to I_TRIG_TTL7
  I_TRIG_ECL0 to I_TRIG_ECL1
  I_TRIG_EXT0 (specifies faceplate 'Trig Out' port)
```

Routing Triggers- HP SICL

```
ivxigettrigroute
ixxitrigroute1
  I_TRIG_ALL
  I_TRIG_TTL0 to I_TRIG_TTL7
  I_TRIG_ECL0 to I_TRIG_ECL1
  I_TRIG_EXT0 (specifies faceplate 'Trig Out' and 'Trig In' ports)
```

Configuring the E8491B Trig In and Trig Out Ports

Configuration of the E8491B external 'Trig In' and 'Trig Out' ports is done through the HP I/O Libraries' 'I/O Config' utility. This portion of the utility is shown in the following figure.

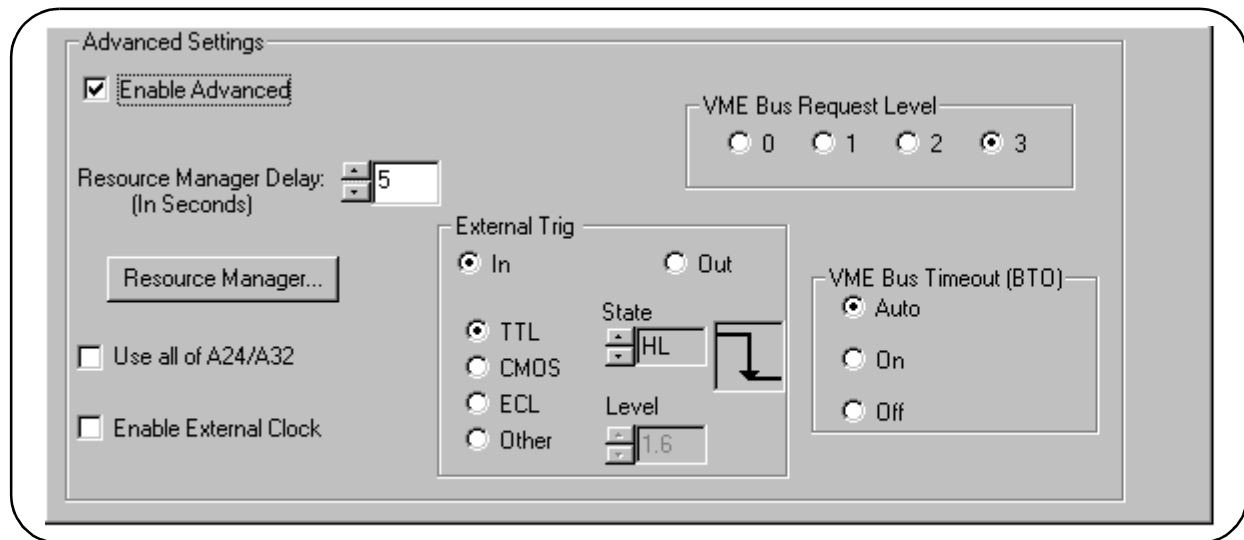

Figure 3-1. Configuring the HP E8491B External Trigger Ports.

When 'External Trig In' is selected, the faceplate 'Trig In' port is configured for the trigger level and state (normally high or normally low) selected. When 'External Trig Out' is selected, the faceplate 'Trig Out' port is configured for the state (normally high or normally low) selected.

1. Trigger routing is only available using the HP SICL `ixxitrigroute` function.

Note The 'I/O Config' help file associated with the HP E8491B interface contains additional information on configuring the faceplate trigger ports.

Triggering Example The following program demonstrates how an external trigger received on the faceplate 'Trig In' port is routed to TTL trigger lines on the VXI backplane.

```
// TRIGSICL.CPP - This program demonstrates how trigger signals are
// generated and routed using the HP E8491B. The program uses SICL functions
// to generate and route a trigger signal from the face plate 'Trig Out'
// port to VXI backplane trigger line TTLTRG4. The signal triggers the
// E1412 multimeter which then takes a burst of 10 readings.

#include "sicl.h"
#include <stdio.h>
#include <stdlib.h>

// project files: trigsicl.cpp, sicl32.lib

void main(void)
{
    INST e8491;// E8491 SICL handle
    INST e1412;// E1412 SICL handle
    short i;
    double dcv_rdgs[10];

    // install SICL error handler
    ionerror(I_ERROR_EXIT);

    // open a (SICL) interface session to the E8491B
    // open a (SICL) device session to the E1412
    e8491 = iopen("vxi");
    e1412 = iopen("vxi,24");

    // set up trigger routing; rout a trigger from the faceplate 'Trig In'
    // port to VXI backplane TTL trigger line 4
    ivxitrigroute(e8491, I_TRIG_EXT0, I_TRIG_TTL4);

    // E1412 Multimeter configuration

    // set a 50s timeout period for external trigger to occur
    itimeout(e1412, 50000);

    // configure the multimeter for DCV measurements
    iprintf(e1412, "CONF:VOLT:DC 8.0\n");

    // set the fastest aperture time
    iprintf(e1412, "VOLT:DC:APER MIN\n");

    // turn off the autozero function
    iprintf(e1412, "ZERO:AUTO OFF\n");
}
```

```

// set the trigger source
iprintf(e1412, "TRIG:SOUR TTLT4\n");//trigger line 4

// set the sample count
iprintf(e1412, "SAMP:COUN 10\n");// 10 readings

// initiate the multimeter
iprintf(e1412, "INIT\n");

printf("Press 'Enter' to trigger the voltmeter\n");
getchar ();

// output a trigger pulse on the E8491B 'Trig Out' connector, the
// trigger is then input to the 'Trig In' connector via a jumper wire
// and routed to TTL trigger line 4 which triggers the multimeter
ixtrig(e8491, I_TRIG_EXT0);

// fetch the readings once the trigger is received
ipromptf(e1412, "FETC?\n", "%,10lf", dcv_rdgs);

// display the readings
for (i=0; i<10; i++)
{
    printf("%lf\n", dcv_rdgs[i]);
}

// close the device sessions
iclose(e8491);// close SICL interface session
iclose(e1412);// close SICL device session
}

```

Comments

1. For demonstration purposes, the trigger signal output from the 'Trig Out' port (ixtrig function) is routed to the 'Trig In' port using a jumper wire. The signal is then routed to TTLTRG4 (ixitrigroute function).

2. The external trigger routed to TTLTRG4 can also be routed to any or all of the VXI backplane trigger lines.

3. When using the faceplate 'Trig In' and 'Trig Out' ports, notice that both ports are specified using I_TRIG_EXT0.

In the program, ixitrigroute(e8491s, I_TRIG_EXT0, I_TRIG_TTL4) routes the trigger received on the faceplate 'Trig In' port to backplane TTL trigger line 4. ixtrig(e8491s, I_TRIG_EXT0) outputs a trigger pulse on the 'Trig Out' port which is connected by a jumper wire to the 'Trig In' port.

4. This manual is included on the HP I/O Libraries CD. By viewing the manual from the CD, you can cut and paste this program into your development environment.

Trigger Pull Up Trigger signals output from the E8491B ‘Trig Out’ port can be “pulled up” to +30V as shown in Figure 3-2.

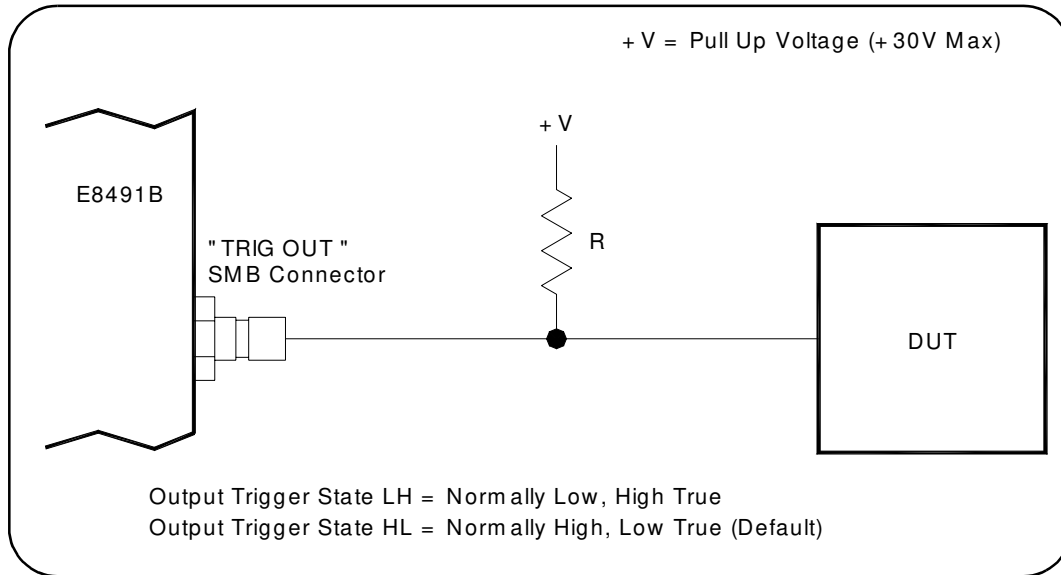

Figure 3-2. Using a Pull Up on the HP E8491B ‘Trig Out’ Port.

Using HP E8491B Shared Memory

The E8491B has 128 kBytes of shared (VME) memory. This memory is in the E8491B’s A24 address space and is available to those VXI instruments capable of mapping and accessing A24 memory. Shared memory is often used as a temporary storage space for data transfers between the PC and VXI instruments.

HP instruments with the ability to store and receive data from shared memory generally implement the SCPI (Standard Commands for Programmable Instruments) MEMory:VME subsystem shown below:

```
MEMory:VME:SIZE
MEMory:VME:ADDRESS
MEMory:VME:STATE
```

Corresponding HP VXIplug&play functions are:

```
hpexxxx_memVmeAddr
hpexxxx_memVmeSize
hpexxxx_memVmeStat
```

where xxxx is the instrument model number.

Locating E8491B Shared Memory

In order to use the E8491B shared memory, you must first locate the starting address of the memory as mapped by the resource manager (see “Running the Resource Manager” in Chapter 2). The address varies from system to system depending on the number of devices that use A24 memory. The address can be determined programatically using HP VISA or SICL, or by viewing the resource manager output. Each method is described in the following sections.

Locating Shared Memory Using HP VISA

For HP VISA programs, the E8491B shared memory starting address is obtained using the function:

```
viGetAttribute
```

and the VXI interface attribute:

```
VI_ATTR_MEM_BASE
```

The HP VISA version of the example “Storing Readings in Shared Memory” demonstrates the use of this function and attribute.

Locating Shared Memory Using SICL

For SICL programs, the E8491B shared memory starting address is found using the function:

```
ivxirminfo
```

This function fills the structure *struct vxinfo*. The item within the structure containing the starting address is *memstart*. The SICL version of the example program showing the use of shared memory demonstrates the use of this function and structure.

Locating Shared Memory by Viewing the Resource Manager Output

The third method of determining the E8491B’s shared memory starting address is to view the resource manager output. “Viewing the Resource Manager Output” in Chapter 2 describes how this is done using the ‘I/O Config’ utility. Figure 3-3 shows the section of the output that indicates A24 address mapping.

Another way to view the output is using the SICL *ivxisc* utility contained in the <drive:>\siclnt\bin or sicl95\bin directory. This utility is an executable that is used with the SICL logical unit number (see “Editing the HP E8491B Configuration” in Chapter 2) to return the configuration output of the resource manager. Again, Figure 3-3 shows a partial listing of the output.

Note Refer to Appendix B for additional information on using *ivxisc* and for an example of the complete configuration output.

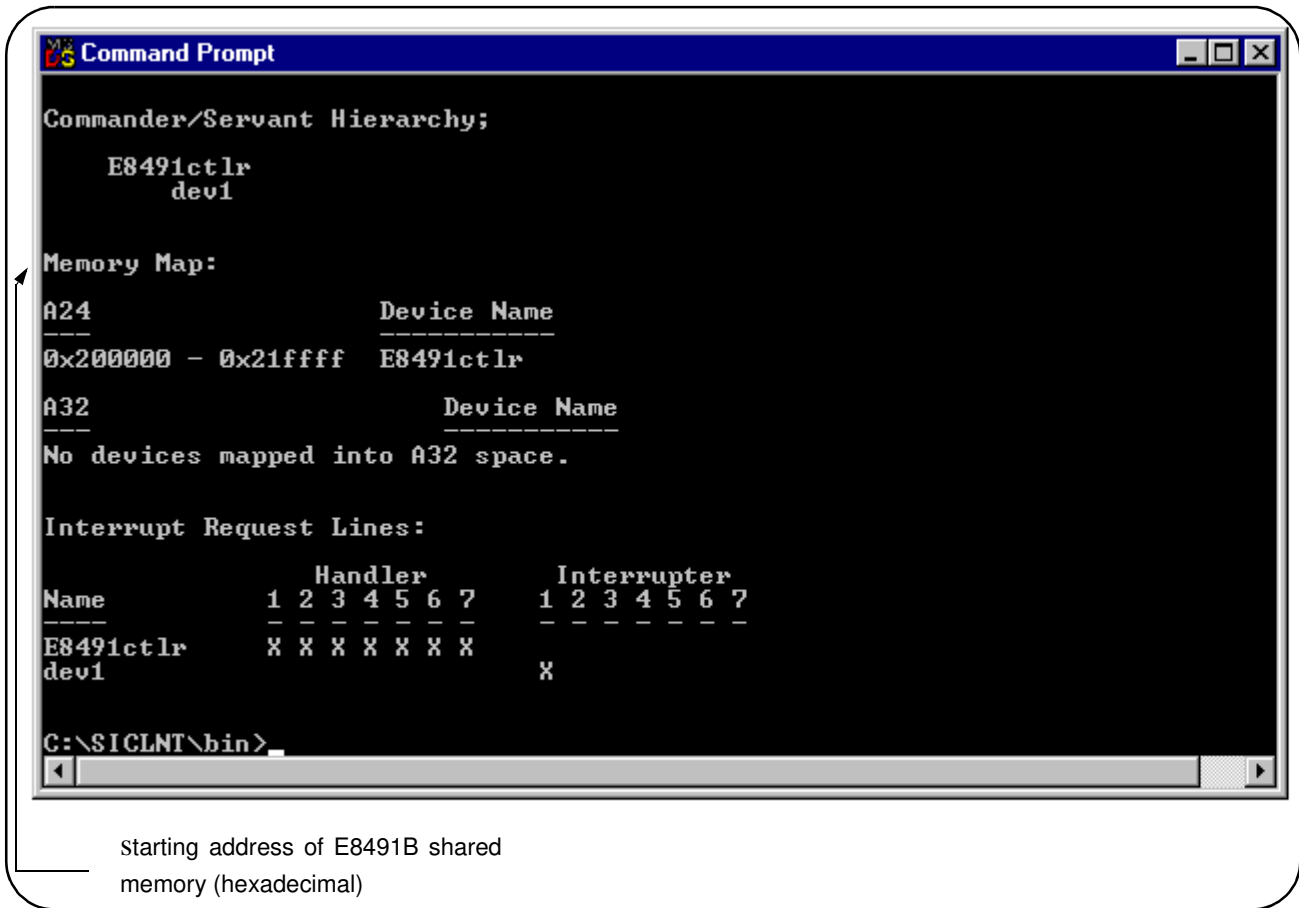

Figure 3-3. Partial Listing of Resource Manager Output Showing Shared Memory Mapping.

Example Programs

The following examples show an application using the E8491B's shared memory. In the program, 8,000 readings are taken with the HP E1410 multimeter. Because the E1410 has only enough memory to store 4,096 readings internally, all 8,000 readings are stored in shared memory and then transferred to the PC. Given the shared memory size of 128 kBytes and the E1410 storage format of eight bytes/reading, up to 16,000 readings can be stored.

Figure 3-4 illustrates the reading transfers performed with the following programs.

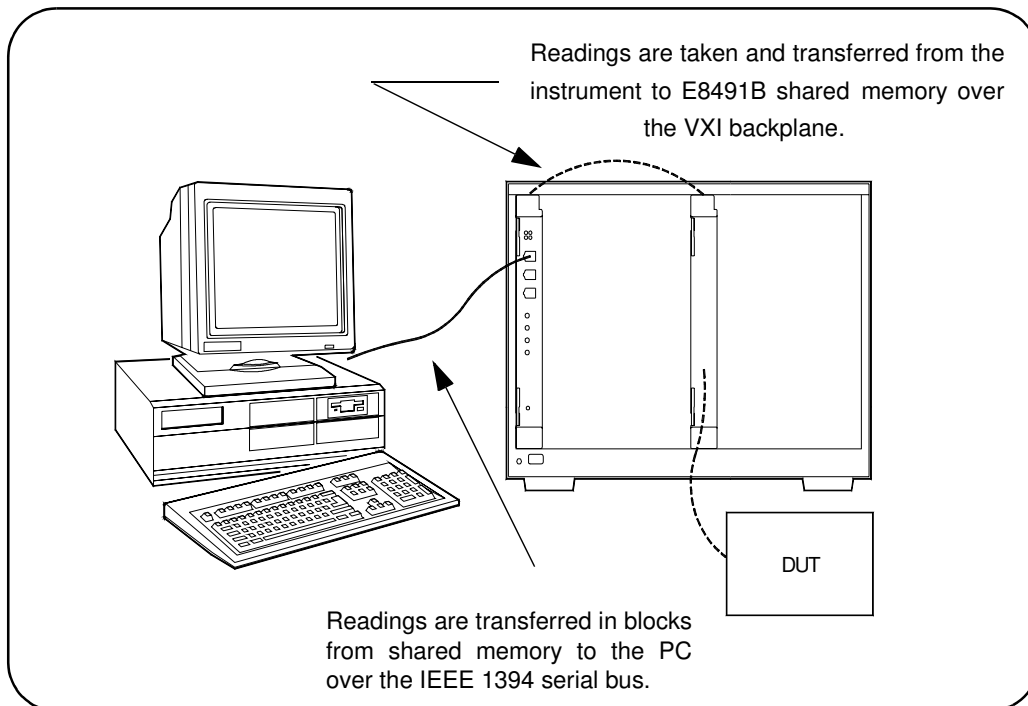

Figure 3-4. Storing Readings in Shared Memory.

Storing Readings in Shared Memory - HP VISA Example

This example uses the HP E1410 *VXIplug&play* driver to configure the multimeter, take the readings, and store them in E8491B shared memory. HP VISA functions are used to transfer the readings from shared memory to the PC.

```
// SHAR_VISA.CPP - This program demonstrates how to access the
// HP E8491B's shared memory. The program stores readings taken
// by the HP E1410 multimeter in HP E8491B shared memory, and then
// transfers those readings from shared memory to the computer.

#include "hpe1410.h" // include the driver header file
#include "visa.h"
#include <stdio.h>
#include <stdlib.h>
#include <windows.h>

// project files: SHAR_VISA.cpp, hpe1410.lib, VISA32.lib

// specify the addressing path to the multimeter
#define E1410 "VXI0::24::INSTR" // E1410 path
#define E8491 "VXI0::0::INSTR" // E8491 path

// check for instrument errors
#define INSTR_ERROR 0xBFFC0D07
```

```

// set up byte swap function for readings transferred from
// E8491B shared memory to the PC
#define SWAP_FLOAT64(rdgs)      \
{ unsigned char src[8];        \
  *((double *)src) = *((double *)rdgs); \
  ((unsigned char *) (rdgs))[0] = ((unsigned char*) (src))[7]; \
  ((unsigned char *) (rdgs))[1] = ((unsigned char*) (src))[6]; \
  ((unsigned char *) (rdgs))[2] = ((unsigned char*) (src))[5]; \
  ((unsigned char *) (rdgs))[3] = ((unsigned char*) (src))[4]; \
  ((unsigned char *) (rdgs))[4] = ((unsigned char*) (src))[3]; \
  ((unsigned char *) (rdgs))[5] = ((unsigned char*) (src))[2]; \
  ((unsigned char *) (rdgs))[6] = ((unsigned char*) (src))[1]; \
  ((unsigned char *) (rdgs))[7] = ((unsigned char*) (src))[0]; \
}

// prototypes
void check(ViSession vi, ViStatus error);
void err_handler(ViSession vi, ViStatus err);

void main(void)
{
  ViSession vi, defaultRM, fw;
  ViStatus errStatus, err;
  unsigned long start_addr; // starting address of shared memory
  ViReal64 rdgs[8000]; // array for readings from shared memory
  int i;
  ViChar err_message[256];

  // open a VXIplug&play device session and reset the multimeter
  errStatus = hpel410_init(E1410, 0, 1, &vi);
  if( VI_SUCCESS > errStatus)
  {
    hpel410_error_message( vi, errStatus, err_message);
    printf("Unable to open %s\n", E1410);
    printf("hpel410_init() returned error message %s\n", err_message);
    return;
  }

  // open a VISA session to the E8491B
  viOpenDefaultRM(&defaultRM);
  viOpen(defaultRM, E8491, VI_NULL, VI_NULL, &fw);

  // get E8491B shared memory base address
  viGetAttribute(fw, VI_ATTR_MEM_BASE, &start_addr);

  // enable multimeter error detection
  hpel410_errorQueryDetect(vi, 1);

  // set a 5s timeout period to allow functions to complete
  errStatus = hpel410_timeOut(vi, 5000);
  check(vi, errStatus);

  // configure the multimeter for DCV measurements

```

```

errStatus = hpel410_confVoltDc(vi);
check(vi, errStatus);

// turn off autorange, set a 30V DCV range
errStatus = hpel410_voltDcRang(vi, 0, 30);
check(vi, errStatus);

// set a 10 us aperture time
errStatus = hpel410_voltDcAper(vi, 10.0e-6);
check(vi, errStatus);

// set 8000 readings
errStatus = hpel410_sampCoun(vi, 8000);
check(vi, errStatus);

// store the readings in HP E8491B shared memory

// specify the E8491B shared memory base address
errStatus = hpel410_memVmeAddr(vi, start_addr);
check(vi, errStatus);

// specify the amount of memory required
// (8000 readings * 8 bytes/reading)
errStatus = hpel410_memVmeSize(vi, 64000);
check(vi, errStatus);

// enable the readings to be stored
errStatus = hpel410_memVmeStat(vi, 1);

// disable multimeter error detection
hpel410_errorQueryDetect(vi, 0);

// initiate the multimeter to take the readings
errStatus = hpel410_initImm(vi);

// pause 30s to allow readings to complete
Sleep (30000);

// transfer the 8,000 readings (64,000 bytes) from the multimeter using
// the VISA function viMoveIn8
err = viMoveIn8(fw, VI_A24_SPACE, 0, 64000, (ViPUInt8)rdgs);
if(err < VI_SUCCESS) err_handler(fw, err);

// swap the bytes once they are transferred from shared memory
for (i=0;i<7999;i++)
{
    SWAP_FLOAT64(&rdgs[i]);
}

// print some readings to verify the transfer was successful
for (i=0; i<10; i++)
{
    printf("%lf\n", rdgs[i]);
}

```

```

// close the device sessions
hpe1410_close(vi); // close E1410 session
viClose(fw); // close E8491 session
}

//*****
// error checking routine

void check (ViSession vi, ViStatus errStatus)
{
    ViInt32 inst_err;
    ViChar err_message[256];

    if(VI_SUCCESS > errStatus)
    {
        if(INSTR_ERROR == errStatus)
        {
            // query instrument error
            hpe1410_dcl(vi); // send a device clear
            hpe1410_error_query(vi, &inst_err, err_message);

            // display the error
            printf("Instrument Error : %ld, %s\n", inst_err, err_message);
        }
        else
        {
            // get driver error message
            hpe1410_error_message(vi, errStatus, err_message);

            // display the error
            printf("HP E1410 Driver Error : %ld, %s\n", errStatus, err_message);
        }

        hpe1410_reset(vi); // reset the multimeter
        hpe1410_close(vi); // close the multimeter handle

        exit(1);
    }

    return;
}

//*****
// Error handling function

void err_handler (ViSession vi, ViStatus err)
{
    char buf[1024]={0};
    viStatusDesc(vi, err, buf);
    printf("ERROR = %s\n", buf);
    return;
}

```

Comments

1. Because of the E1410 multimeter data storage format (eight bytes / reading), the readings are transferred from shared memory to the PC in bytes. Therefore, it is necessary to swap each byte in order to re-construct the reading. Depending on the storage formats of your particular instruments, swapping may not be necessary.

2. This manual is included on the HP I/O Libraries CD. By viewing the manual from the CD, you can cut and paste this program into your development environment.

Storing Readings in Shared Memory - SICL Example

This example uses the HP E1410 *VXIplug&play* driver to configure the multimeter, take the readings, and store them in E8491B shared memory. SICL functions are used to transfer the readings from shared memory to the PC.

```
// SHAR_SICL.CPP - This program demonstrates how to access the
// HP E8491B's shared memory. The program stores readings taken by
// the HP E1410 multimeter in HP E8491B shared memory, and then
// transfers those readings from shared memory to the computer.

#include "sicl.h"
#include <stdio.h>
#include <stdlib.h>
#include <windows.h>

// project files: SHAR_SICL.cpp, SICL32.lib

// set up byte swap function for readings transferred from
// E8491B shared memory to the PC

#define SWAP_FLOAT64(rdgs) \
{ unsigned char src[8]; \
  *((double *)src) = *((double *)rdgs); \
  ((unsigned char *) (rdgs))[0] = ((unsigned char*) (src))[7]; \
  ((unsigned char *) (rdgs))[1] = ((unsigned char*) (src))[6]; \
  ((unsigned char *) (rdgs))[2] = ((unsigned char*) (src))[5]; \
  ((unsigned char *) (rdgs))[3] = ((unsigned char*) (src))[4]; \
  ((unsigned char *) (rdgs))[4] = ((unsigned char*) (src))[3]; \
  ((unsigned char *) (rdgs))[5] = ((unsigned char*) (src))[2]; \
  ((unsigned char *) (rdgs))[6] = ((unsigned char*) (src))[1]; \
  ((unsigned char *) (rdgs))[7] = ((unsigned char*) (src))[0]; \
}

void main(void)
{
  INST e8491;          // handle for SICL session to E8491
  INST e1410;         // handle for SICL session to E1410
  struct vxiiinfo info; // structure for data returned by ivxirminfo
  unsigned long start_addr; // starting address of shared memory
  double rdgs[8000];    // array for readings from shared memory
  short i;
  unsigned long map;    // memory map space
}
```

```

// install SICL error handler
ionerror(I_ERROR_EXIT);

// open a (SICL) interface session to the E8491B
// open a (SICL) device session to the E1410
e8491 = iopen("vxi");
e1410 = iopen("vxi,24");

// read the VXI resource manager information in order to determine
// the E8491B shared memory starting address
ivxirminfo(e8491, 0, &info);
start_addr = info.memstart;

// convert address from pages to an address
start_addr = (start_addr*256);

// map E8491B memory space for transfer of readings from
// E8491B shared memory to the computer
map = imapx(e8491, I_MAP_SHARED, 0, 1);

// set a 5s timeout period to allow functions to complete
itimeout(e8491, 5000);
itimeout(e1410, 5000);

// configure the multimeter for DCV measurements
iprintf(e1410, "CONF:VOLT:DC 30.0\n");

    // set a 10 us aperture time
    iprintf(e1410, "VOLT:APER 10.0e-6\n");

    // set 8000 readings
    iprintf(e1410, "SAMP:COUN 8000\n");

// store the readings in HP E8491B shared memory

// specify the E8491B shared memory base address
iprintf(e1410, "MEM:VME:ADDR %d\n", start_addr);

// specify the amount of memory required
// (8000 readings * 8 bytes/reading)
iprintf(e1410, "MEM:VME:SIZE 64000\n");

// enable the reading to be stored
iprintf(e1410, "MEM:VME:STAT 1\n");

// initiate the multimeter to take the readings
iprintf(e1410, "INIT\n");

// pause 30s to allow readings to complete and to transfer
// to shared memory
Sleep (30000);

```

```

// transfer the (8000) readings from the multimeter using the SICL
// function iblockmovex - the parameters are id, source handle, source
// offset, source width, source increment, destination handle, destination
// offset, destination width, destination increment, count, and swap

iblockmovex(e8491, map, 0, 8, 1, 0, (unsigned long) rdgs, 8, 1, 64000, 0);

// swap the bytes once they are transferred from shared memory
for (i=0;i<7999;i++)
{
    SWAP_FLOAT64(&rdgs[i]);
}

// print some readings to verify the transfer was successful
for (i=0; i<10; i++)
{
    printf("%lf\n", rdgs[i]);
}

// unmap memory
iunmapx(e8491, map, I_MAP_SHARED, 0, 1);

// close the device sessions
iclose(e8491); // close SICL interface session
iclose(e1410); // close SICL device session
}

```

Comments

1. Because of the E1410 multimeter data storage format (eight bytes / reading), the readings are transferred from shared memory to the PC in bytes. Therefore, it is necessary to swap each byte in order to re-construct the reading. Depending on the storage formats of your particular instruments, swapping may not be necessary.
2. This manual is included on the HP I/O Libraries CD. By viewing the manual from the CD, you can cut and paste this program into your development environment.

Chapter 4

IEEE 1394 Fundamentals and Interface Overview

Using this Chapter

This chapter contains reference information on the IEEE 1394 Serial Bus, the data transfer protocol, and on the related hardware. The contents of the chapter include:

- IEEE 1394 Topology and Terminology 57
- IEEE 1394 Data Transfer Protocol 59
- The OHCI-Compatible Host Adapter and Interface Cable.. 61
- The HP E8491B PC to VXI Interconnect 62
- The HP I/O Libraries. 64

IEEE 1394 Topology and Terminology

Optimizing the IEEE 1394 bus must include an understanding of the topology and terms associated with its use. Figure 4-1 shows a VXI system consisting of a PC and three VXI mainframes - interconnected with the IEEE 1394 bus.

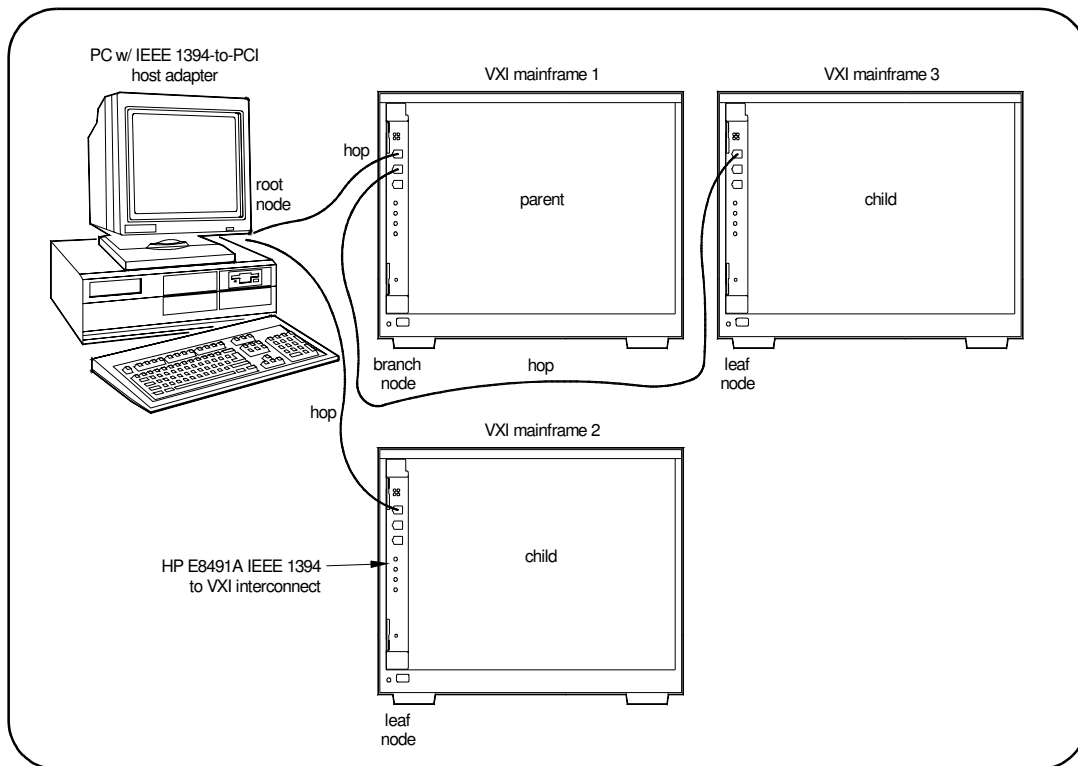

Figure 4-1. IEEE 1394 Topology and Terms.

The terms shown in Figure 4-1 are defined in the following table.

Table 4-1. Definition of Terms.

Host Adapter	Links the computer's PCI bus to the IEEE 1394 interface. To use a host adapter, computers must be PCI Rev. 2.0 compliant.
HP E8491B 1394-to-VXI Interconnect	Links the IEEE 1394 interface to the VXI backplane. Provides the backplane's clock and trigger resources.
Root Node	Each device (HP E8491B) on the bus is a "node." In VXI systems, the PC is always the root node having cycle master and bus master capabilities.
Branch Node	A branch node has IEEE 1394 cables connected to two or more ports. In Figure 1, VXI mainframe 1 is a branch node because of the 1394 cables connecting it to the PC (root node) and to VXI mainframe 3 on its right.
Leaf Node	A leaf node has a single IEEE 1394 cable connected to it. VXI mainframes 2 and 3 are leaf nodes.
Parent	A node (HP E8491B) is a parent if it is physically connected closer to the root than an adjacent node. In Figure 1, VXI mainframe 1 is a parent node because it is closer to the root than VXI mainframe 3.
Child	A node (HP E8491B) is a child if it is farther from the root than an adjacent node. In Figure 1, VXI mainframe 3 is a child node because it is farther from the root than VXI mainframe 1. A node with a single IEEE 1394 cable connected to it (leaf node) is always a child (VXI mainframe 2).
Hop	A hop is a IEEE 1394 cable link between nodes. There can be no more than 16 hops between any two nodes. In the diagram above, there is a maximum of three hops between nodes. The distance between any two nodes cannot exceed 72m.

Features of the IEEE 1394 Bus

The following features of the IEEE 1394 bus apply to all bus applications including VXI systems.

- * Daisy-chain or branching configurations are allowed. There can be no closed loops (i.e. more than one connection between any two devices).
- * Up to 63 devices (including 16 HP E8491Bs) are allowed per bus segment. One host adapter represents one bus segment.
- * There is a maximum of 16 hops between any two devices. The bus cable length cannot exceed 72 meters between any two devices.
- * Live/hot connections. A VXI mainframe anywhere in the configuration can be turned on/off without affecting the other mainframes. The IEEE 1394 bus automatically reconfigures itself any time a VXI mainframe (or other device) is added or removed. It is best to do this however, if there are no data transactions taking place elsewhere in the system.

Optimizing the Configuration

I/O performance is impacted slightly by the hardware configuration. The VXI mainframe closest to the PC (root node) has the highest priority. For example, if instruments in VXI mainframes 1 and 3 (Figure 4-1) contend for the bus at the same time, the root node will grant mainframe 1 access to the bus first. However, the bus's fair arbitration protocol (covered in the next section) ensures that each device has equal access to the bus and that devices closer to the root are not continually granted the bus.

IEEE 1394 Data Transfer Protocol

Data transfer over the IEEE 1394 bus can be either asynchronous or isochronous¹. Hewlett-Packard's IEEE 1394 based VXI systems use asynchronous data transfers and a "fair arbitration" protocol to ensure each VXI mainframe has equal access to the bus. Figure 4-2 illustrates the concepts of asynchronous data transfers and fair arbitration.

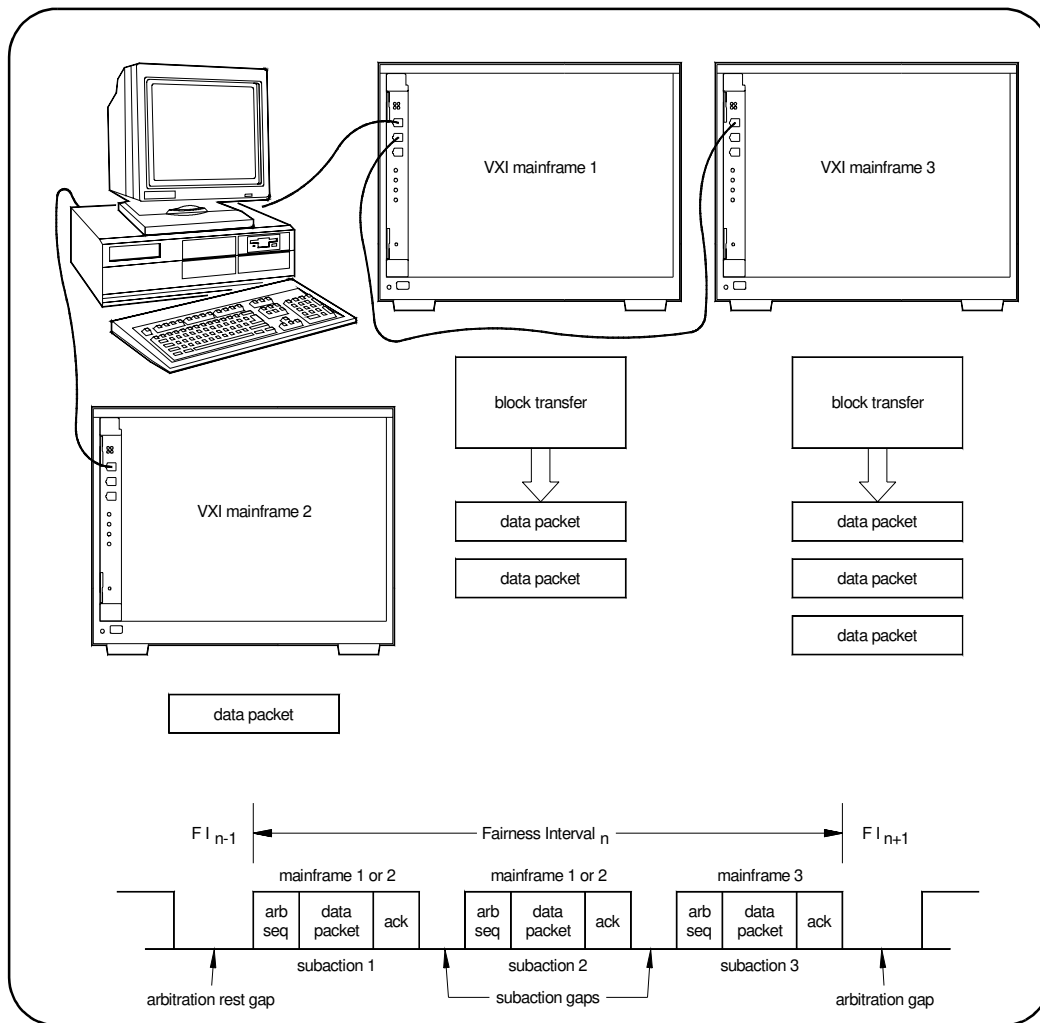

Figure 4-2. IEEE 1394 Data Transfer Protocol.

1. Isochronous data transfers broadcast variable amounts of data at regular intervals with no acknowledgement. Isochronous and Asynchronous data transfers can occur on the same bus.

Asynchronous Data Transfers

During an asynchronous data transfer, a variable amount of data is transferred to an explicit address in real time, and an acknowledgement is returned. Data is transferred across the IEEE 1394 bus in packets called “subactions.” An asynchronous subaction is made up of three parts:

* arbitration sequence - the period when a device requests control of the bus in order to transmit a data packet.

* data packet - the data packet consists of a data prefix that contains information about the transaction, the data itself (e.g. VXI instrument commands), and a data end signal. The maximum packet size is 2 kByte for 400 Mbit adapters such as the adapter supplied with the E8491B.

* acknowledgement - a code returned by the (addressed) data destination indicating the action taken by the receiver.

The periods between subactions are called subaction gaps. The subaction gap allows devices that have not had control of the bus during the current “fairness interval” to arbitrate for control.

Fair Arbitration Protocol

The fair arbitration protocol is based on the fairness interval shown in Figure 2. A fairness interval consists of one or more subactions in which data packets are transferred over the bus. A fairness interval is as follows:

1. The interval begins when devices (HP E8491B’s) arbitrate for control of the bus.
2. When a device is granted control, it transfers its data packet and is then disabled from arbitrating until the next fairness interval.
3. A subaction gap occurs after the previous data packet is transferred. During this period, remaining devices arbitrate for the bus. The next device granted the bus transfers its data packet and is then disabled from arbitrating until the next fairness interval.
4. The fairness interval ends after each device has had an opportunity to access to the bus and the arbitration reset gap, which is longer than the subaction gap, occurs. The arbitration reset gap re-enables each device for arbitration during the next fairness interval.

VXI Data Transfers

To take advantage of the IEEE 1394 data transfer protocol, large amounts of data should be transferred between VXI instruments and the PC using block transfers. During a block transfer, data is divided into the packets described previously; the number of packets depends on the amount of data and whether a 200 Mbit or 400 Mbit host adapter is used. Compared to protocols that transfer data one byte or one word at a time, transfer speed between the instrument and the PC is increased because the IEEE 1394 protocol overhead is associated with the fairness interval and with each packet, rather than with each byte or word transferred. Thus, transfer speeds (bits/second) over the IEEE 1394 bus increase as the amount of data transferred (block size) increases.

OHCI-Compatible Host Adapter and Interface Cable

The OHCI-compatible PCI-to-IEEE 1394 host adapter is a PC plug-in card¹ capable of transferring data at up to 400 MBits/second. The adapter has three external IEEE 1394 ports. Each OHCI adapter represents one bus segment capable of supporting up to 63 nodes. If required, the OHCI adapter can supply 12V with a maximum total current of 0.5A to all three 1394 ports for IEEE 1394 devices that require power. The layout of a typical adapter is shown below.

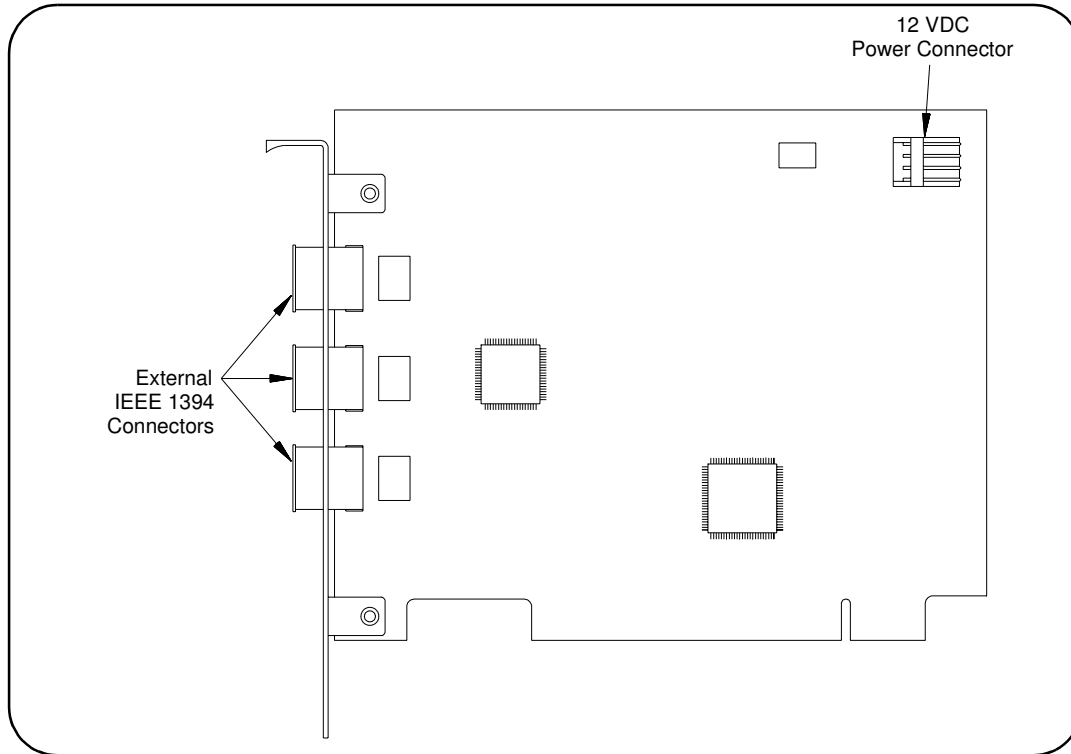

Figure 4-3. Layout of a Typical OHCI PCI-to-IEEE 1394 Host Adapter.

The interface cable supplied with the host adapter has two power wires and two signal twisted-pairs. A cross-section of the cable and the cable connector is shown in Figure 4-4.

1. In the future, IEEE 1394 will be a standard port on selected PCs.

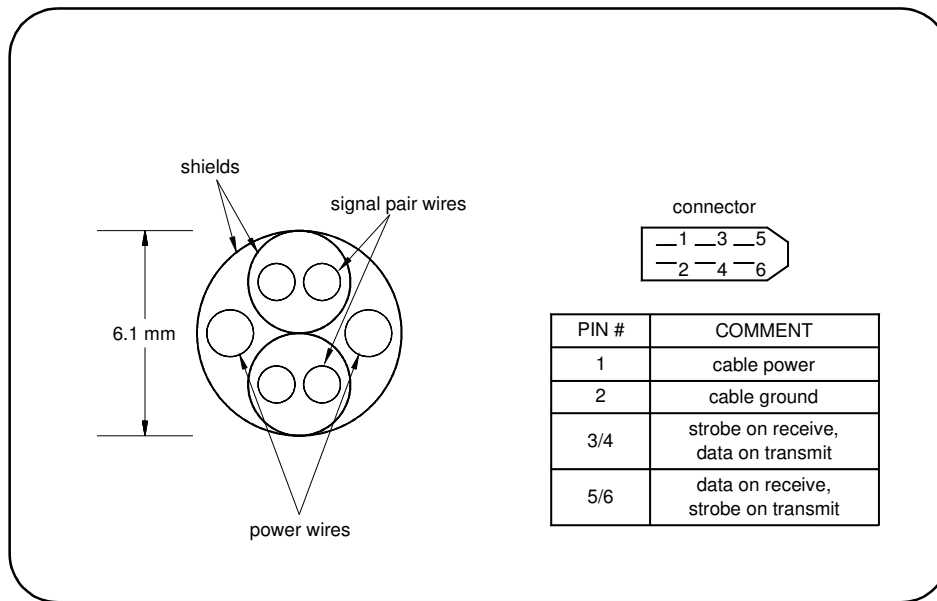

Figure 4-4. Cross-section of the IEEE 1394 Cable.

The power wires route power from the host adapter to devices (nodes) on the bus, whether the devices are turned on or off. Since each device in the system acts as a repeater, the power supplied to a device that is turned off enables signals to be transferred across that device. This maintains signal continuity throughout the system.

The HP E8491B PC to VXI Interconnect

The E8491B is a VXI C-size device (Figure 4-5) normally installed in mainframe slot 0. With a logical address of 0, the E8491B functions as the mainframe's resource manager via software included with the I/O libraries. The E8491B has 128 kBytes of shared RAM and contains many of the clock and triggering features found on the HP E1406A Command Module - a VXI resource manager/slot 0 device common in many GPIB-based systems. A VXI mainframe with the HP E8491B in slot 0 can also be powered on/off at any time without affecting other mainframes in the system.

The HP E8491B IEEE 1394 interconnect links the VXI backplane to the IEEE 1394 bus. However, the E8491B and the IEEE 1394 bus do not extend the (VXI) backplane between frames in multi-frame VXI systems. This means that the multimeter and multiplexers in a VXI scanning multimeter for example, must be installed in the same mainframe. Devices sharing the VXI Local bus must also be installed in the same mainframe VXI Local bus.

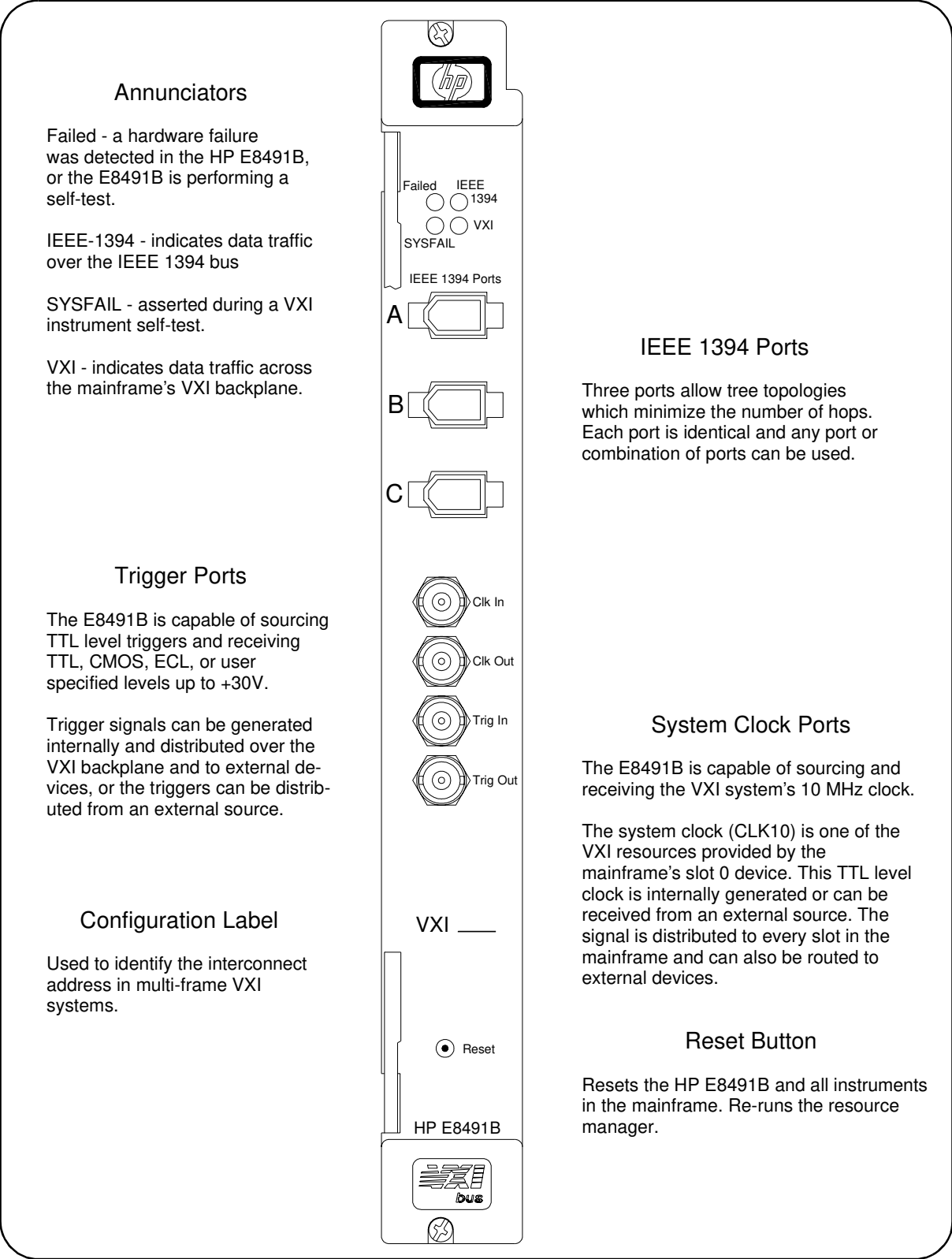

Annunciators

Failed - a hardware failure was detected in the HP E8491B, or the E8491B is performing a self-test.

IEEE-1394 - indicates data traffic over the IEEE 1394 bus

SYSFAIL - asserted during a VXI instrument self-test.

VXI - indicates data traffic across the mainframe's VXI backplane.

Trigger Ports

The E8491B is capable of sourcing TTL level triggers and receiving TTL, CMOS, ECL, or user specified levels up to +30V.

Trigger signals can be generated internally and distributed over the VXI backplane and to external devices, or the triggers can be distributed from an external source.

Configuration Label

Used to identify the interconnect address in multi-frame VXI systems.

IEEE 1394 Ports

Three ports allow tree topologies which minimize the number of hops. Each port is identical and any port or combination of ports can be used.

System Clock Ports

The E8491B is capable of sourcing and receiving the VXI system's 10 MHz clock.

The system clock (CLK10) is one of the VXI resources provided by the mainframe's slot 0 device. This TTL level clock is internally generated or can be received from an external source. The signal is distributed to every slot in the mainframe and can also be routed to external devices.

Reset Button

Resets the HP E8491B and all instruments in the mainframe. Re-runs the resource manager.

Figure 4-5. The HP E8491B IEEE 1394 to VXI Interconnect.

Using the HP E8491B with the HP E1406 Command Module

Though not a common configuration, the HP E1406 command module can be used in the same mainframe as the HP E8491 to provide HP-IB access to instruments. In this configuration, however, the E8491B must be the mainframe's resource manager. See the section titled "Alternate Configurations" in Chapter 2, page 19.

The HP I/O Libraries

The software required to use the IEEE 1394 interface in a VXI system is contained in the HP I/O Libraries and HP VXI*plug&play* Drivers. The software supports the Windows 95 and Windows NT platforms.

The software "stack" shown below shows the relationship of the VXI*plug&play* drivers to HP VISA/ SICL, to the host adapter drivers, and to the VXI instruments. Notice that Hewlett-Packard's implementation of the IEEE 1394 interface requires HP VISA and will not work with the VISA supplied by other vendors.

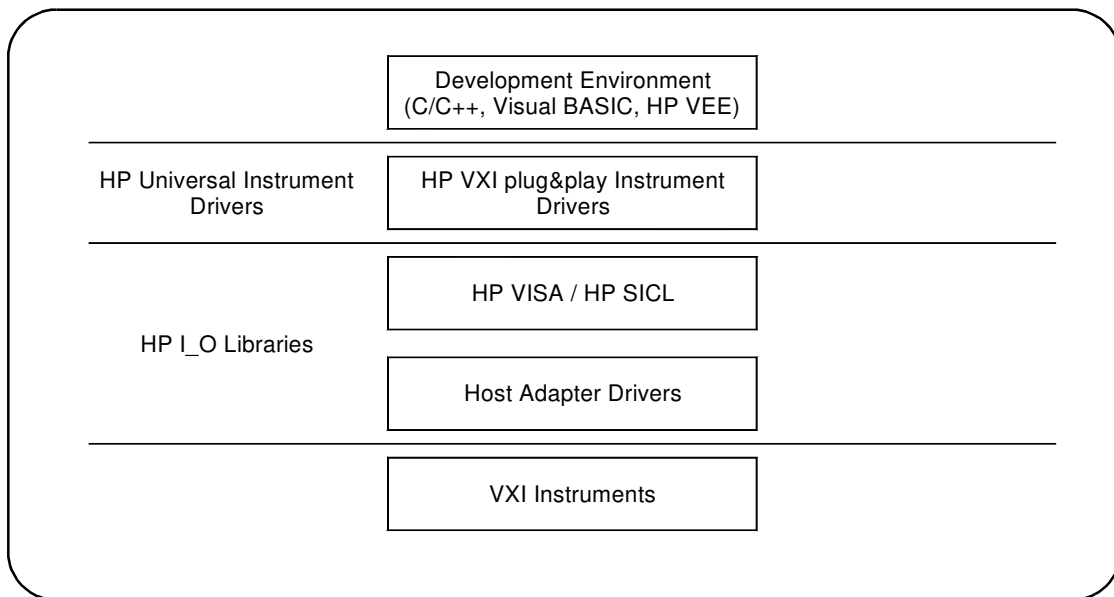

Figure 4-6. System Software and Drivers.

Most application programs are written using the instruments' VXI*plug&play* drivers. The plug&play driver functions make subsequent calls to the VISA functions and so on. Message-based instruments can be programmed at the HP VISA / SICL level by embedding SCPI commands in the HP VISA / SICL functions.

Appendix A Specifications

The following specifications define the operating and performance characteristics of the HP E8491B.

Interface Characteristics

Operating System	Windows 95 Windows NT
Controllers	PC based
I/O Library	SICL / VISA
Backplane	PCI
Interface	IEEE 1394
Maximum I/O Speed*	16-bit: 1.76 MBytes/s to PC 2.50 MBytes/s to HP E8491B
* 200 MHz Pentium PC / 400 MHz Selectron Host	32 bit: 1.0 MByte/s to PC 1.0 MByte/s to HP E8491B
Languages	C/C++, Visual Basic, HP VEE, LabView

VXI Characteristics General

VXI Device Type	Message-based commander
Data transfer bus	n/a
Slot 0 functionality	Yes
Resource Manager Functionality	Yes
MXIbus Resource Manager	Yes
Size	C
Slots	1
Connectors	P1 / P2
Shared Memory	128 kBytes
VXI busses	TTL trigger bus, ECL trigger bus
C-size compatibility	n/a

CLK 10

Clk In	
Input	TTL
Frequency Stability	100 ppm
Duty Cycle	50% ± 5%
Clk Out	
Output	TTL
Frequency Stability	100 ppm
Duty Cycle	50% ± 5%

External Trigger Input

Connector	SMB (on faceplate)
Levels	TTL, CMOS, ECL, 0 to +33V
Programmable Threshold Range	0 to +30V
Programmable Threshold Accuracy	± 0.4V
Threshold Sensitivity (hysteresis)	0.5 Vpp maximum 0.1 Vpp minimum
Input Load	50 pf, 55 kohms
Maximum Rate	2 MHz
Minimum Pulse Width	200 ns

External Trigger Output

Connector	SMB (on faceplate)
Levels	nominal pull up to + 5V
Maximum External Pull Up	+ 30V
Sink Current	10 mA @ $V_{ol} \leq 0.4V$ or 150 mA @ $V_{ol} \leq 1.0V$

Trigger Delays

Maximum delay from TTLTRG to ECLTRG	60 ns
Maximum delay from ECLTRG to TTLTRG	60 ns
Maximum delay from Trig In port to ECLTRG or TTLTRG	300ns
Maximum delay from TTLTRG or ECLTRG to Trig Out port	100 ns

Cooling

Watts / slot	20W
ΔP mm H ₂ O	0.10
Air flow liters / s	2.0

Power Supply Loading

	I_{PM} (amps)	I_{DM} (amps)
+5V	2.5	0.001
+12V	0.35	0.050
-12V	0.015	0.001
+24V	0.0	0.0
-24V	0.0	0.0
-5.2V	0.180	0.001
-2V	0.360	0.001

Appendix B

Editing the HP E8491B Resource Manager Configuration

Introduction

The resource manager functionality provided through the HP E8491B configures your VXI system based on rules specified by the VXI standard. The configuration can be viewed or modified through the configuration files and utility functions outlined in this appendix.

Configuration File Overview

Configuration files (.cf extension) are placed in the <drive:>\sic1nt\defaults or \sic195\defaults directory when the HP I/O Libraries are installed. Except where noted, the following files can be edited from the HP I/O Libraries' 'I/O Config' utility (Figure B-1) as shown on the following pages. When editing a file, note the following:

1. Add your entry(ies) below the commented (lines).
2. The first column must contain an entry. Any number of spaces can separate remaining entries on the line.

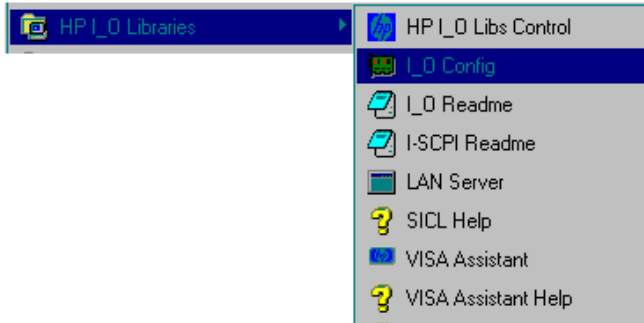

1. From the I/O Libraries program group, click I/O Config.

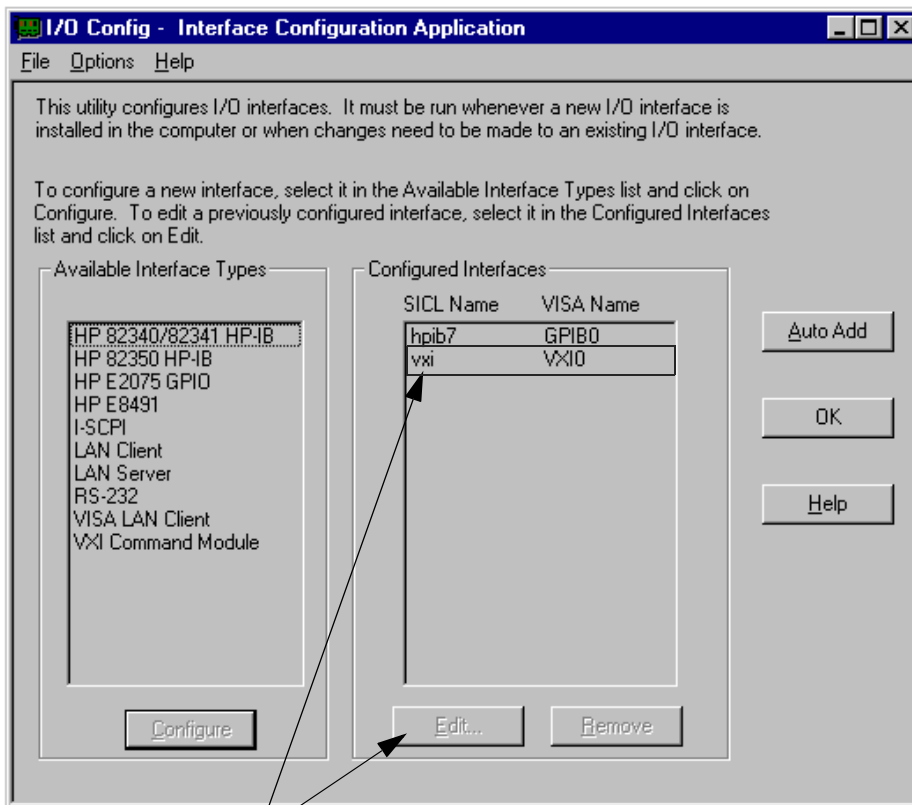

2. Select the configured HP E8491B interface and then click Edit. This brings up the window (partial view) in Figure B-2.

Figure B-1. Editing Configuration Files from the 'I/O Config' Utility.

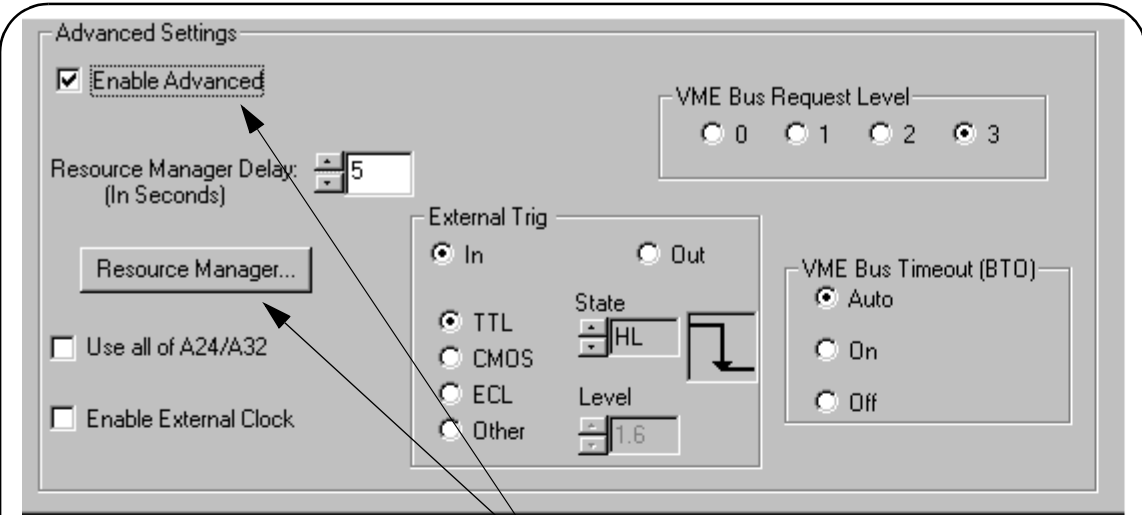

3. Check Enable Advanced and then click Resource Manager...

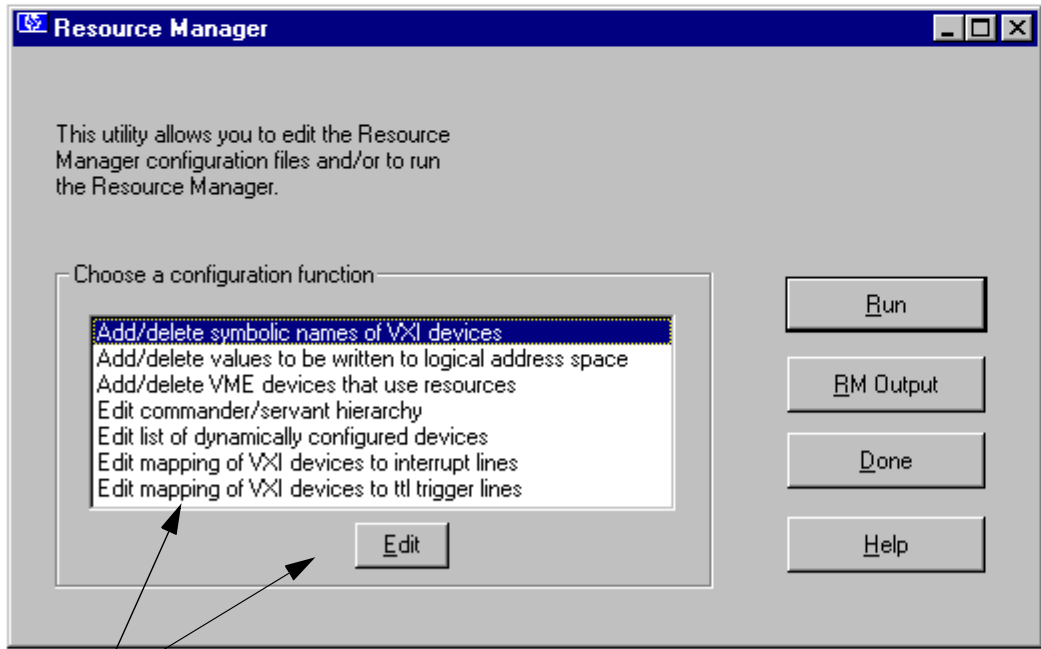

4. Select the portion of the configuration to edit and then click Edit.

Figure B-2. Editing Configuration Files from the 'I/O Config' Utility (cont'd).

The names.cf Configuration File

The *names.cf* file is a database that contains a list of symbolic names to assign VXI devices that have been configured. The *ivxirm* utility reads the model id number from the VXI device and the *ivxisc* utility uses that information and this file to print out the VXI device symbolic name. If you add a new VXI device to your system that is not currently in the database, you may want to add an entry to this file.

This file is edited by selecting “Add/delete symbolic names of VXI devices” in the Resource Manager window (Figure B-2).

The oride.cf Configuration File

The *oride.cf* file contains values to be written to logical address space for register-based instruments. This data is written to A16 address space after the resource manager runs, but before the system’s resources are released. This can be used for custom configuration of register-based instruments every time the resource manager runs.

This file is edited by selecting “Add/delete values to be written to logical address space” in the Resource Manager window (Figure B-2).

The vmedev.cf Configuration File

The *vmedev.cf* file contains a list of VME devices that use resources in the VXI cardcage. Since the resource manager is unable to detect VME devices, the resource manager uses this information to determine such things as the slot number where the VME device is located, what type (A16, A24, or A32) and how much memory it uses, and what interrupt lines it uses. Additionally, the resource manager verifies that multiple resources aren’t allocated. This file is also used by the *ivxisc* utility to print out information about the devices.

This file is edited by selecting “Add/delete VME devices that use resources” in the Resource Manager window (Figure B-2).

The cmdrsrvt.cf Configuration File

The *cmdrsrvt.cf* file contains a commander/servant hierarchy other than the default for the VXI system. The resource manager will set up the commander/servant hierarchy according to the commander’s logical addresses and the servant area switch. However, you can use this file to override the default based on the commander’s servant area. This file should only contain changes from the default.

This file is edited by selecting “Edit commander/servant hierarchy” in the Resource Manager window (Figure B-2).

The dynamic.cf Configuration File

The *dynamic.cf* file contains a list of VXI devices to be dynamically configured. You only need to add entries to this file if you want to override the default dynamic configuration assignment by the resource manager. Normally, if you have a dynamically configurable device and the logical address is set at 255, the resource manager will assign the first available address. However, if a dynamically configurable device has an entry in this file, the resource manager will assign the address listed in the file.

This file is edited by selecting “Edit list of dynamically configured devices” in the Resource Manager window (Figure B-2).

The irq.cf Configuration File

The *irq.cf* file is a database that maps specific interrupt lines to VXI interrupt handlers. If you have non-programmable interrupters and you want the interrupters to be recognized by a VXI interrupt handler, you must make an entry in this file. Additionally, if you have programmable interrupters and you want them to be recognized by a device other than what's assigned by the resource manager (the commander of that device), you can make an entry in this file to override the default. Keep in mind that not all VXI devices need to use interrupt lines and not all interrupt lines need to be assigned. Note that any interrupt lines assigned in this file cannot also be assigned in the *vmedev.cf* configuration file.

This file is edited by selecting "Edit mapping of VXI devices to interrupt lines" in the Resource Manager window (Figure B-2).

The ttltrig.cf Configuration File

The *ttltrig.cf* file contains the mapping of VXI devices to TTL trigger lines in extended VXI systems. If you have a MXI-extended (multiple-mainframe) system and you are sending / receiving triggers between mainframes, you must map the TTL trigger line to the logical address of the device asserting the trigger. This file is only used for extended VXI systems.

This file is edited by selecting "Edit mapping of VXI devices to ttl trigger lines" in the Resource Manager window (Figure B-2).

The vximanuf.cf Configuration File

The *vximanuf.cf* file contains a database that cross references the VXI manufacturer id numbers and the name of the manufacturer. The *ivxirm* utility reads the manufacturer id number from the VXI device. The *ivxisc* utility then uses that number and this file to print out the name of the manufacturer. If you add a new VXI device from a vendor that is not currently in the file, you may want to add an entry to the file.

This file can not be edited using 'I/O Config'.

The vximodel.cf Configuration File

The *vximodel.cf* file contains a database that lists a cross reference of manufacturer id, model id, and VXI device names. The *ivxirm* utility reads the model id number from the VXI device and the *ivxisc* utility uses that information and this file to print out the VXI device model. If you add a new VXI device to your system that is not currently in this database, you may want to add an entry to this file.

This file can not be edited using 'I/O Config'.

Utility Function Overview

Within the <drive:>\sicInt\bin or \sic195\bin directory are utility functions that view the resource manager output (*ivxisc*) and which clear the HP E8491B interface (*iclear*) and run the resource manager (if the *iproc* utility is running).

Using ivxisc

The *ivxisc* function is used to view the resource manager output. *ivxisc* is executed from the Windows command (DOS) prompt (.\sicInt\bin or \sic195\bin directory) as:

```
ivxisc vxi<logical unit>
```

where <logical unit> is the value from the 'Logical Unit' window in the HP I/O Libraries 'I/O Config' utility. An example of the output produced by *ivxisc* is shown in Figures B-3 and B-4.

```

Command Prompt
UXI Current Configuration:

UXI Bus: 0
Device Logical Addresses: 0 16
Slots:
  0 1 2 3 4 5 6 7 8 9 10 11 12
Empty
Single Device      X
Multiple Devices
UME
Failed

UXI Device Table:
Name              LADD Slot Bus Manufacturer      Model
-----
E8491ctrl        0    0   0 Hewlett-Packard    E8491      1394 UXI Control
w/Slot 0
dev1             16    5   0 Hewlett-Packard    E1412A    6.5 Digit Multime

UME Device Table:
Name              Bus Slot Space Size
-----
No UME cards configured.

Failed Devices:
Name              Bus Slot Manufacturer      Model
-----
No FAILED devices detected.

Protocol Support <Msg Based Devices>:
Name              CMDR SIG MSTR INT FHS SMP RG EG ERR PI PH TRG I4 I LW ELW 1.3
-----
E8491ctrl        X    X  X
dev1              X    X  X
  
```

Figure B-3. Output of *ivxisc*.

```

Command Prompt

Commander/Servant Hierarchy;

  E8491ctrl
    dev1

Memory Map:

A24
-----
0x200000 - 0x21ffff  E8491ctrl

A32
-----
No devices mapped into A32 space.

Interrupt Request Lines:

Name          Handler          Interrupter
-----
              1 2 3 4 5 6 7      1 2 3 4 5 6 7
E8491ctrl    X X X X X X X      X
dev1

```

Figure B-4. Output of ivxisc (cont'd).

Using iclear

The *iclear* function is used to clear the interface (HP E8491B) or individual message-based instruments in the VXI mainframe. *iclear* is executed from the DOS command prompt (..\siclnt\bin or \sicl95\bin directory) as:

```
iclear <SICL interface name, [logical address]>
```

SICL interface name is the name (vxi) listed in the 'I/O Config' SICL Interface Name window. logical address is the address of the message-based VXI instrument to be cleared.

If a logical address is not specified, the (E8491B) interface is cleared and the resource manager is started.

A

alternate configurations, [19](#)
applying power, [33](#)
asynchronous data transfers, [60](#)

B

BIOS, [33](#)
Block, [36-37, 40](#)
block data transfers, [36](#)
 using HP VISA, [40](#)
 using HP VXIplug&play drivers, [37](#)
bus-mastering PCI slot, [33](#)

C

CLK 10 specifications, [66](#)
cmdrsrvt.cf, [72](#)
configuration file overview, [69](#)
configuration files
 cmdrsrvt.cf, [72](#)
 dynamic.cf, [72](#)
 irq.cf, [73](#)
 names.cf, [72](#)
 oride.cf, [72](#)
 ttltrg.cf, [73](#)
 vmedev.cf, [72](#)
 vximanuf.cf, [73](#)
 vximodel.cf, [73](#)
configuring the E8491B interconnect, [24](#)
configuring the Trig In and Trig Out ports, [44](#)
connecting the HP E8491B to the host adapter, [18](#)
cooling, [67](#)

D

data transfer protocol, [59](#)
 asynchronous transfers, [60](#)
 fair arbitration, [60](#)
data transfers
 over VXI, [60](#)
dynamic.cf, [72](#)

E

E1406
 using the E8491B with, [19](#)
E8491B
 configuring, [24](#)
 editing the configuration, [26](#)
 Windows 95 platforms, [27](#)
examples
 HP VISA block data transfers, [40](#)
 HP VXIplug&play block data transfers, [37](#)
 storing readings in shared memory - HP
 VISA, [50](#)
 storing readings in shared memory - SICL, [54](#)
 triggering, [45](#)
external trigger input
 specifications, [66](#)
external trigger output
 specifications, [66](#)

F

fair arbitration, [60](#)
first time configuration, [24](#)

H

host adapter and interface cable
 overview, [61](#)
HP E1406
 using the command module with the HP
 E8491B, [64](#)
HP E8491B
 connecting the host adapter, [18](#)
 installation, [17](#)
 overview, [62](#)
 triggering, [43](#)
HP I/O Libraries
 installation, [24](#)
 overview, [64](#)
HP VXIplug&play drivers
 installation, [28](#)

I

- I/O Libraries
 - installation, [24](#)
- iclear, [75](#)
- IEEE 1394
 - bus features, [58](#)
 - data transfer protocol, [59](#)
 - topology and terminology, [57](#)
- IEEE 1394 host adapter
 - installation, [13](#)
- installation
 - A/B-size instruments, [22](#)
 - C-size instruments, [21](#)
 - host adapter, [13](#)
 - HP E8491B, [17](#)
 - HP I/O Libraries, [24](#)
 - HP VXIplug&play drivers, [28](#)
 - verifying, [29](#)
 - VXI instruments, [20](#)
- installation problems, troubleshooting, [33](#)
- Installing, [21–22](#)
- instrument sessions
 - opening, [35](#)
- interface cable and host adapter
 - overview, [61](#)
- interface characteristics
 - specifications, [65](#)
- ipro, [33](#)
- IRQ line, [33](#)
- irq.cf, [73](#)
- ivxisc, [73](#)

L

- loading
 - power supply, [67](#)
- locating E8491B shared memory, [47](#)
- locating shared memory
 - using HP SICL, [48](#)
 - using HP VISA, [48](#)

M

- message-based instruments
 - programming, [35](#)
- MXI
 - using the E8491B with MXI systems, [19](#)

N

- names.cf, [72](#)

O

- opening instrument sessions, [35](#)
 - HP VISA, [36](#)
 - HP VXIplug&play, [35](#)
 - SICL, [36](#)
- optimizing programs, [36](#)
- oride.cf, [72](#)

P

- PCI BIOS, [33](#)
- plug&play drivers
 - installation, [28](#)
- porting SICL programs, [36](#)
- power supply loading, [67](#)
- programming register-based and message-based VXI instruments, [35](#)
- pull up, Trig Out port, [47](#)

R

- register-based instruments
 - programming, [35](#)
- resource manager, [33](#)
 - viewing the output, [30](#)
- resource manager configuration
 - editing, [26](#)
- running the resource manager, [33](#)

S

- shared memory, [47](#)
 - locating using HP VISA, [48](#)
 - locating using SICL, [48](#)
- shared memory examples, [49](#)
- SICL programs
 - porting for use with the E8491B, [36](#)
- soft front panels
 - for installation verification, [29](#)
- specifications
 - CLK 10, [66](#)
 - cooling, [67](#)
 - external trigger input, [66](#)
 - external trigger output, [66](#)
 - general, [65](#)
 - interface characteristics, [65](#)
 - power supply loading, [67](#)
 - trigger delays, [67](#)
- storing readings in shared memory
 - HP VISA example, [50](#)
 - SICL example, [54](#)

T

- Trig In
 - specifications, [66](#)
- Trig In port
 - configuring, [44](#)
- Trig Out port
 - configuring, [44](#)
 - specifications, [66](#)
- trigger delay
 - specifications, [67](#)
- triggering, [43](#)
 - example, [45](#)
 - pull up, [47](#)
- troubleshooting installation problems, [33](#)
- ttltrg.cf, [73](#)
- turning on the mainframe, [33](#)

U

- Using, [47](#)
- using HP E8491B shared memory, [47](#)
- using instrument soft front panels, [29](#)
- using the HP E8491B with the HP E1406 Command Module, [64](#)
- utility functions, [73](#)
 - iclear, [75](#)
 - ivxisc, [73](#)

V

- verifying the installation, [29](#)
- viewing the resource manager output, [30](#)
- vmedev.cf, [72](#)
- VXI characteristics
 - specifications, [65](#)
- VXI data transfers, [60](#)
- VXI instruments
 - installation, [20](#)
 - installing A/B-size, [22](#)
 - installing C-size, [21](#)
- vximanu.cf, [73](#)
- vximodel.cf, [73](#)
- VXI-MXI systems
 - using the E8491B with, [19](#)
- VXIplug&play drivers
 - installation, [28](#)

