



HP E1403C and HP E1407A C-Size Active Adapter Module

Installation and User's Manual

Where to Find it - Online and Printed Information:

System installation (hardware/software) VXIbus Configuration Guide*
HP VIC (VXI installation software)*

Module configuration and wiring This Manual

VXI*plug&play* programming VXI*plug&play* Online Help

VXI*plug&play* example programs VXI*plug&play* Online Help

VXI*plug&play* function reference VXI*plug&play* Online Help

Soft Front Panel information VXI*plug&play* Online Help



VISA language information HP VISA User's Guide

HP VEE programming information HP VEE User's Manual

**Supplied with HP Command Modules, Embedded Controllers, and VXLink.*



Manual Part Number: E1403-90034
Printed in U.S.A. E0397





Warranty	3
Safety Symbols	4
WARNINGS	4
Declaration of Conformity	5
Reader Comment Sheet	7
Chapter 1	
General Information	9
Introduction.....	9
C-Size Adapter Description.....	9
HP E1403C Adapter Description	9
HP E1407A Adapter Description	10
Chapter 2	
Installation/Removal Instructions	11
Preparing for Installation	11
Installing A-Size VMEbus Modules (HP E1403C Only).....	11
Installing an Adapter Module with a B-Size VXIbus Module	12
Removing the Adapter Module and B-Size Module	15
Chapter 3	
Using the Adapters	17
HP E1403C Block Diagram.....	17
HP E1403C Connector Pinout	18
HP E1407A Block Diagram	19
HP E1407A Connector Pinout.....	20
Installing the J2 Connector Cable (HP E1407A Only).....	21
Purpose of the J2 Cable	21
Install the J2 Cable	21
Ribbon Cable (J2) Connector Pinout	23
Selecting the TTL Trigger Direction (HP E1407A Only)	24
Selecting the ECL Trigger Direction (HP E1407A Only).....	25
SUMBUS Configurations (HP E1407A Only).....	26
Disconnecting the SUMBUS	26
Adding Buffer Circuitry to the SUMBUS	26
Appendix A	
HP E1403C and HP E1407A Specifications	27
Product Characteristics	27
Power Requirements	27
Cooling Requirements	27
Index	29



Certification

Hewlett-Packard Company certifies that this product met its published specifications at the time of shipment from the factory. Hewlett-Packard further certifies that its calibration measurements are traceable to the United States National Institute of Standards and Technology (formerly National Bureau of Standards), to the extent allowed by that organization's calibration facility, and to the calibration facilities of other International Standards Organization members.

Warranty

This Hewlett-Packard product is warranted against defects in materials and workmanship for a period of three years from date of shipment. Duration and conditions of warranty for this product may be superseded when the product is integrated into (becomes a part of) other HP products. During the warranty period, Hewlett-Packard Company will, at its option, either repair or replace products which prove to be defective.

For warranty service or repair, this product must be returned to a service facility designated by Hewlett-Packard (HP). Buyer shall prepay shipping charges to HP and HP shall pay shipping charges to return the product to Buyer. However, Buyer shall pay all shipping charges, duties, and taxes for products returned to HP from another country

HP warrants that its software and firmware designated by HP for use with a product will execute its programming instructions when properly installed on that product. HP does not warrant that the operation of the product, or software, or firmware will be uninterrupted or error free.

Limitation Of Warranty

The foregoing warranty shall not apply to defects resulting from improper or inadequate maintenance by Buyer, Buyer-supplied products or interfacing, unauthorized modification or misuse, operation outside of the environmental specifications for the product, or improper site preparation or maintenance.

The design and implementation of any circuit on this product is the sole responsibility of the Buyer. HP does not warrant the Buyer's circuitry or malfunctions of HP products that result from the Buyer's circuitry. In addition, HP does not warrant any damage that occurs as a result of the Buyer's circuit or any defects that result from Buyer-supplied products.

NO OTHER WARRANTY IS EXPRESSED OR IMPLIED. HP SPECIFICALLY DISCLAIMS THE IMPLIED WARRANTIES OF MERCHANTABILITY AND FITNESS FOR A PARTICULAR PURPOSE.

Exclusive Remedies

THE REMEDIES PROVIDED HEREIN ARE BUYER'S SOLE AND EXCLUSIVE REMEDIES. HP SHALL NOT BE LIABLE FOR ANY DIRECT, INDIRECT, SPECIAL, INCIDENTAL, OR CONSEQUENTIAL DAMAGES, WHETHER BASED ON CONTRACT, TORT, OR ANY OTHER LEGAL THEORY.

Notice

The information contained in this document is subject to change without notice. HEWLETT-PACKARD (HP) MAKES NO WARRANTY OF ANY KIND WITH REGARD TO THIS MATERIAL, INCLUDING, BUT NOT LIMITED TO, THE IMPLIED WARRANTIES OF MERCHANTABILITY AND FITNESS FOR A PARTICULAR PURPOSE. HP shall not be liable for errors contained herein or for incidental or consequential damages in connection with the furnishing, performance or use of this material. This document contains proprietary information which is protected by copyright. All rights are reserved. No part of this document may be photocopied, reproduced, or translated to another language without the prior written consent of Hewlett-Packard Company. HP assumes no responsibility for the use or reliability of its software on equipment that is not furnished by HP.

U.S. Government Restricted Rights

The Software and Documentation have been developed entirely at private expense. They are delivered and licensed as "commercial computer software" as defined in DFARS 252.227- 7013 (Oct 1988), DFARS 252.211-7015 (May 1991) or DFARS 252.227-7014 (June 1995), as a "commercial item" as defined in FAR 2.101(a), or as "Restricted computer software" as defined in FAR 52.227-19 (June 1987)(or any equivalent agency regulation or contract clause), whichever is applicable. You have only those rights provided for such Software and Documentation by the applicable FAR or DFARS clause or the HP standard software agreement for the product involved



HP E1403C/E1407A User's Manual
Edition 4

Copyright © 1997 Hewlett-Packard Company. All Rights Reserved.

Documentation History

All Editions and Updates of this manual and their creation date are listed below. The first Edition of the manual is Edition 1. The Edition number increments by 1 whenever the manual is revised. Updates, which are issued between Editions, contain replacement pages to correct or add additional information to the current Edition of the manual. Whenever a new Edition is created, it will contain all of the Update information for the previous Edition. Each new Edition or Update also includes a revised copy of this documentation history page.

Edition 1 May 1993
Edition 2 January 1995
Edition 3 December 1996
Edition 4 March 1997

Safety Symbols



Instruction manual symbol affixed to product. Indicates that the user must refer to the manual for specific WARNING or CAUTION information to avoid personal injury or damage to the product.



Alternating current (AC)



Direct current (DC).



Indicates hazardous voltages.



Indicates the field wiring terminal that must be connected to earth ground before operating the equipment. Protects against electrical shock in case of fault.

WARNING

Calls attention to a procedure, practice, or condition that could cause bodily injury or death.

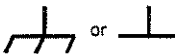

Frame or chassis ground terminal—typically connects to the equipment's metal frame.

CAUTION

Calls attention to a procedure, practice, or condition that could possibly cause damage to equipment or permanent loss of data.

WARNINGS

The following general safety precautions must be observed during all phases of operation, service, and repair of this product. Failure to comply with these precautions or with specific warnings elsewhere in this manual violates safety standards of design, manufacture, and intended use of the product. Hewlett-Packard Company assumes no liability for the customer's failure to comply with these requirements.

Ground the equipment: For Safety Class 1 equipment (equipment having a protective earth terminal), an uninterruptible safety earth ground must be provided from the mains power source to the product input wiring terminals or supplied power cable.

DO NOT operate the product in an explosive atmosphere or in the presence of flammable gases or fumes.

For continued protection against fire, replace the line fuse(s) only with fuse(s) of the same voltage and current rating and type. **DO NOT** use repaired fuses or short-circuited fuse holders.

Keep away from live circuits: Operating personnel must not remove equipment covers or shields. Procedures involving the removal of covers or shields are for use by service-trained personnel only. Under certain conditions, dangerous voltages may exist even with the equipment switched off. To avoid dangerous electrical shock, **DO NOT** perform procedures involving cover or shield removal unless you are qualified to do so.

DO NOT operate damaged equipment: Whenever it is possible that the safety protection features built into this product have been impaired, either through physical damage, excessive moisture, or any other reason, **REMOVE POWER** and do not use the product until safe operation can be verified by service-trained personnel. If necessary, return the product to a Hewlett-Packard Sales and Service Office for service and repair to ensure that safety features are maintained.

DO NOT service or adjust alone: Do not attempt internal service or adjustment unless another person, capable of rendering first aid and resuscitation, is present.

DO NOT substitute parts or modify equipment: Because of the danger of introducing additional hazards, do not install substitute parts or perform any unauthorized modification to the product. Return the product to a Hewlett-Packard Sales and Service Office for service and repair to ensure that safety features are maintained.

Declaration of Conformity
according to ISO/IEC Guide 22 and EN 45014

Manufacturer's Name: Hewlett-Packard Company
Loveland Manufacturing Center

Manufacturer's Address: 815 14th Street S.W.
Loveland, Colorado 80537

declares, that the product:

Product Name: A/B to C-Size Active Adapter

Model Number: HP E1403C/HP E1407A

Product Options: All

conforms to the following Product Specifications:

Safety: IEC 1010-1 (1990) Incl. Amend 1 (1992)/EN61010-1 (1993)
CSA C22.2 #1010.1 (1992)
UL 3111-1 (1994)

EMC: CISPR 11:1990/EN55011 (1991): Group1 Class A
EN50082-1:1992
IEC 801-2:1991: 4kVCD, 8kVAD
IEC 801-3:1994: 3 Vm
IEC 801-4:1988: 1 kV Power Line, 0.5 kV Signal Lines
ENV50141: 1993/prEN50082-1 (1995): 3 Vrms
ENV50142: 1994/prEN50082-1 (1995): 1 kVCM, 0.5 kVDM
IEC1000-4-8:1993/prEN50082-1 (1995): 3 A/m
EN61000-4-11: 1994/prEN50082-1 (1995): 30%, 10ms 60%, 100 ms

Supplementary Information: The product herewith complies with the requirements of the Low Voltage Directive 73/23/EEC and the EMC Directive 89/336/EEC (inclusive 93/68/EEC) and carries the "CE" marking accordingly.

Tested in a typical configuration in an HP C-Size VXI mainframe.



Jim White, QA Manager

May 1, 1996

European contact: Your local Hewlett-Packard Sales and Service Office or Hewlett-Packard GmbH, Department HQ-TRE, Herrenberger Straße 130, D-71034 Böblingen, Germany (FAX +49-7031-14-3143)

Notes:

Reader Comment Sheet
HP E1403C/E1407A User's Manual
Edition 4

You can help us improve our manuals by sharing your comments and suggestions. **In appreciation of your time, we will enter you in a quarterly drawing for a Hewlett-Packard Palmtop Personal Computer** (U.S. government employees are not eligible for the drawing).

_____	_____
Your Name	City, State/Province
_____	_____
Company Name	Country
_____	_____
Job Title	Zip/Postal Code
_____	_____
Address	Telephone Number with Area Code

Please list the system controller, operating system, programming language, and plug-in modules you are using.

fold here



**NO POSTAGE
NECESSARY
IF MAILED
IN THE
UNITED STATES**

BUSINESS REPLY MAIL
FIRST CLASS PERMIT NO. 37 LOVELAND, CO

POSTAGE WILL BE PAID BY ADDRESSEE

HEWLETT-PACKARD COMPANY
Measurement Systems Division
Learning Products Department
P.O. Box 301
Loveland, CO 80539-9984



cut along this line



fold here

Please pencil-in one circle for each statement below:

Disagree ←————→ Agree

- The documentation is well organized.
- Instructions are easy to understand.
- The documentation is clearly written.
- Examples are clear and useful.
- Illustrations are clear and helpful.
- The documentation meets my overall expectations.

Please write any comments or suggestions below—be specific.



Introduction

The manual is separated into the following chapters.

Chapter 1 - General Information. Describes the different adapters.

Chapter 2 - Installation/Removal Instructions. This chapter shows how to install/remove B-Size VXIbus modules into/from the HP E1403C or HP E1407A C-Size Adapter Module, and how to install/remove the adapter module into a C-Size VXIbus Mainframe.

Chapter 3 - Using the Adapters. This chapter shows how to use the adapter modules. It includes a block diagram for both the HP E1403C and HP E1407A Adapter Modules. The chapter also includes, for the HP E1407A Adapter Module, instructions on how to use and install the J2 Connector Cable, how to select the direction (to or from the mainframe's backplane) of the trigger signals on the ECL and TTL trigger lines, and how to select unbuffered or buffered SUMBUS connections. Connector pinout diagrams for both the HP E1403C and HP E1407A are also provided.

Appendix A - Specifications. This appendix details specifications for the HP E1403C and HP E1407A C-Size Adapter Module.

C-Size Adapter Description

The HP E1403C and HP E1407A Adapter Modules allow an A- or B-Size VMEbus/VXIbus module to connect to a C-Size VXIbus Mainframe. The regular adapters connect a single slot VMEbus/VXIbus module to the mainframe. Option 10 connects two-slot modules to the mainframe (however, it only connects the module to the P1 and/or P2 connector of only one slot). The following gives the features of the adapters.

HP E1403C Adapter Description

Use this adapter to make buffered connections between an A-size or B-size module's J1 connector and the mainframe's P1 connector. The adapter has the following features:

- Mounts with the VMEbus/VXIbus module's front panel flush with the front of the adapter.
- Provides direct access to the VMEbus/VXIbus module's front panel I/O connections.
- Provides connections to the J1 connector with pin-to-pin compatibility to the mainframe's P1 connector.

- Meets VMEbus driving and loading specifications.
- Provides proper timing for data Transfer Acknowledgment (DTACK) and Interrupt Signals (IRQ).
- Provides connectivity for HP B-size modules or any P1-only VXibus slave module (Bus Master signals are not provided. These include: BBSY*, BLCR*, BR0*, BR1*, BR2*, BR3*, SERCLK, SERDAT.)

HP E1407A Adapter Description

Use this adapter to make buffered connections between an A-size or B-size module's J1 connector and the mainframe's P1 connector, and buffered connections between a B-size module's J2 connector and the mainframe's P2 connector. The adapter has the following features:

- Mounts with the VMEbus/VXibus module's front panel flush with the front of the adapter.
- Provides direct access to the VMEbus/VXibus module's front panel I/O connections.
- Provides connections to the J1 connector with pin-to-pin compatibility to the mainframe's P1 connector.
- Provides direct connections to the J2 connector with pin-to-pin compatibility to the mainframe's P2 connector.
- Provides buffered data, address, and trigger lines (either ECL or TTL).
- Provides direct SUMBUS connections, or provides fused $\pm 12\text{V}$ power supply connections to add user provided circuitry (op-amps, for example) for buffered SUMBUS connections (jumper selectable).
- Provides access to the pins on the outer rows of the J2 connector for VME modules. These pins may be isolated from the backplane.
- Meets VMEbus driving and loading specifications.
- Provides proper timing for data Transfer Acknowledgment (DTACK) and Interrupt Signals (IRQ).
- Provides connectivity for HP B-size modules or any P1-only VXibus slave module (Bus Master signals are not provided. These include: BBSY*, BLCR*, BR0*, BR1*, BR2*, BR3*, SERCLK, SERDAT.)

Installation/Removal Instructions

This chapter shows how to install/remove B-size VXIbus modules into/from the HP E1403C or HP E1407A C-Size Adapter Module, and how to install/remove the adapter module into a C-Size VXIbus Mainframe.

Note The procedures in this chapter shows installation/removal of the Adapter Module into/from the HP E1401A High Power Mainframe. The procedures for other mainframes are similar to these procedures.

Preparing for Installation

- Be sure to set the logical address of the module to be installed into the adapter to the correct address (see the module manual).
- Be sure to use clean handling and anti-static handling of the module.
- Be sure there are no external connections to the modules.

Installing A-Size VMEbus Modules (HP E1403C Only)

Install A-Size VMEbus Modules only in the HP E1403C Adapter Module. Use the following B-Size Module installation procedure to install an A-Size Module into the adapter module.

Installing an Adapter Module with a B-Size VXibus Module

The procedure starting on the next page shows how to install an HP E1403C or HP E1407A C-Size Adapter Module into an HP E1401A Mainframe. (The installation procedures for other mainframes is similar.) The procedure then shows how to install a B-Size VXibus Module into the adapter module.

Note During power-up, the resource manager recognizes a module in the slot with the HP E1403C or HP E1407A Adapter Module installed with or without a B-Size module installed in the adapter module. Thus, to prevent any error generation, be sure a B-Size module is installed in the adapter module before power-up.

1 Line up the C-Size Adapter Module's Rails with the Module Guides of an Empty Slot in the Mainframe.

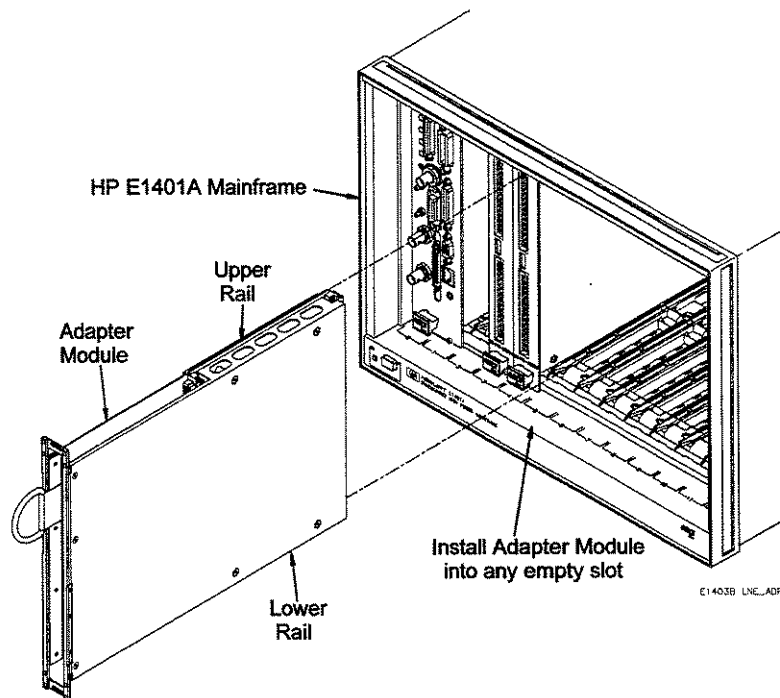

2 Slide the C-Size Adapter Module into the Mainframe.

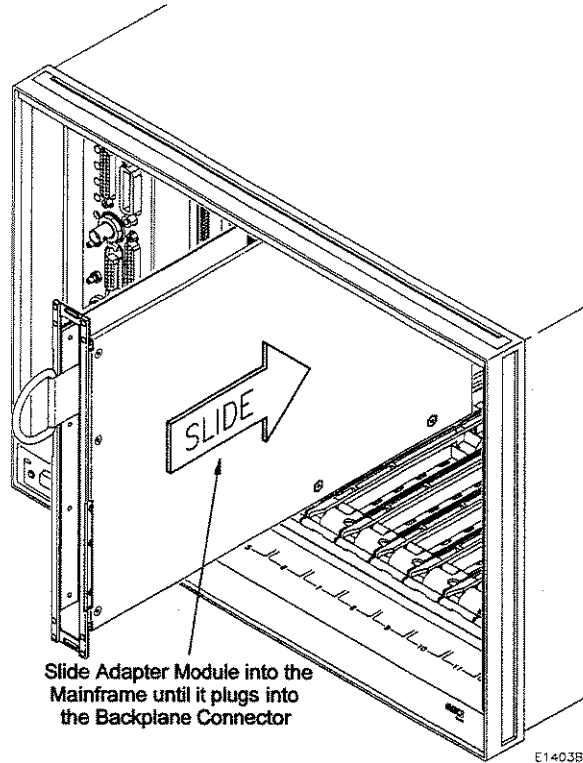

3 Line up the B-Size Module with the C-Size Adapter Module's Front Slot and the Mainframe's Module Guides.

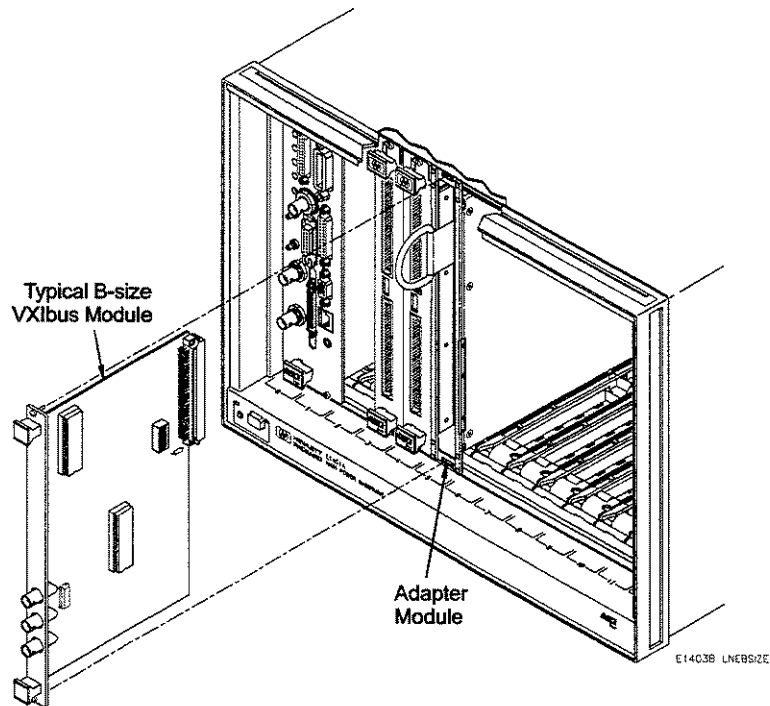

4 Slide the B-Size Module into the C-Size Adapter Module.

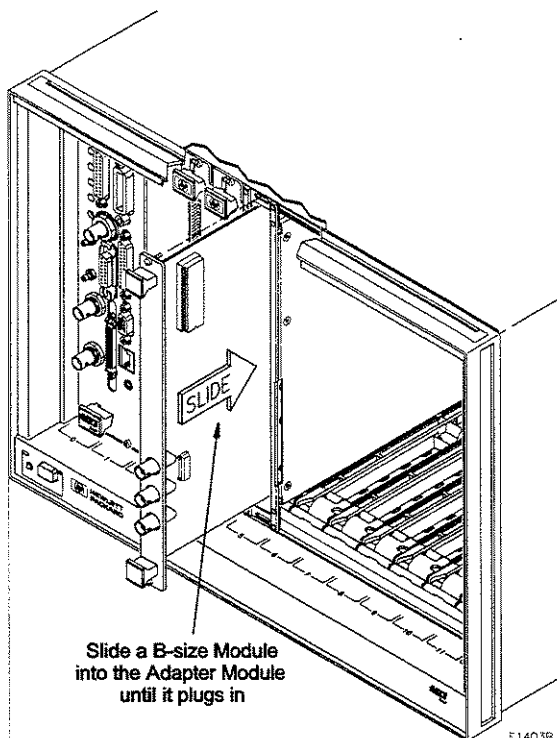

5 Tighten the B-Size Module's Upper and Lower Retainer Screws.

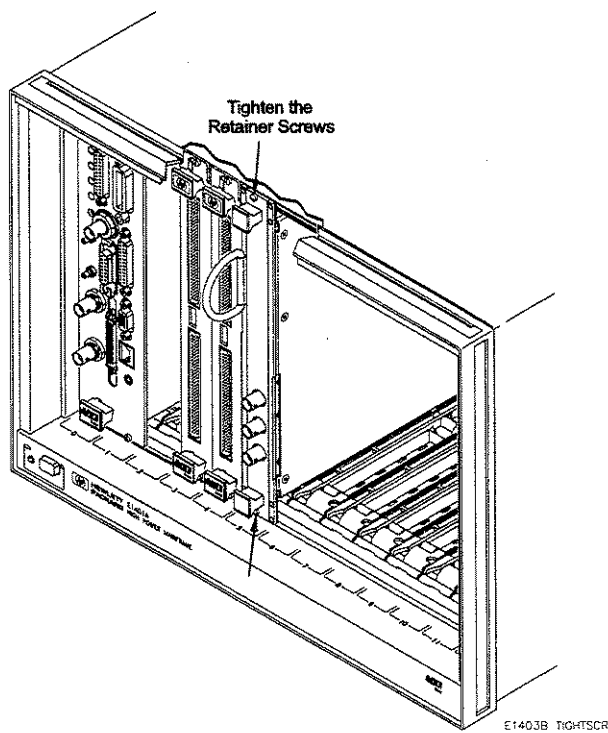

Removing the Adapter Module and B-Size Module

The following procedure shows how to remove a B-Size VXIbus Module from an HP E1403C or HP E1407A C-Size Adapter Module and the adapter module from the mainframe.

- 1 Loosen the Upper and Lower Retainer Screws of the B-Size Module inside the C-Size Adapter Module.**

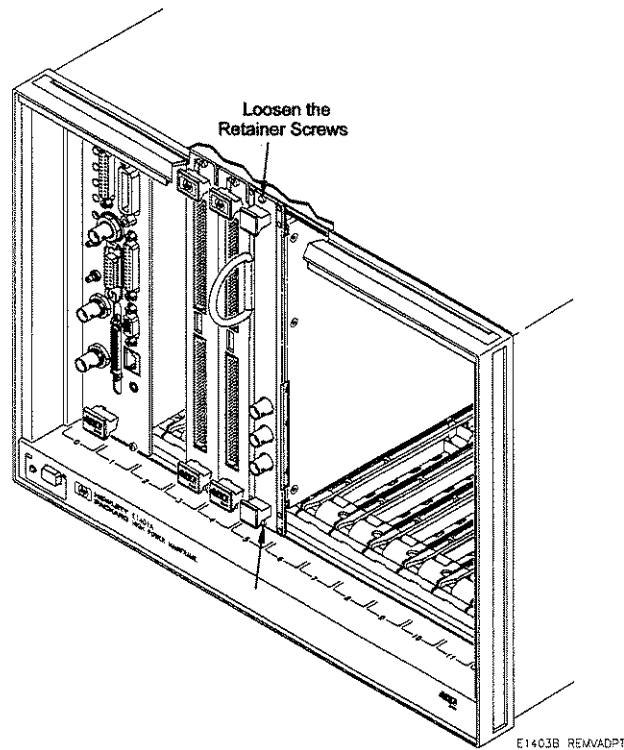

Continued on Next Page

2 Using the handles on the B-Size Module, pull the Module out of the C-Size Adapter Module.

NOTE:

When removing the B-size Module from the Adapter Module, the Adapter Module may be pulled out of the mainframe. If that happens, carefully pull the B-size Module out of the Adapter Module, without damaging any exposed components on the B-size Module.

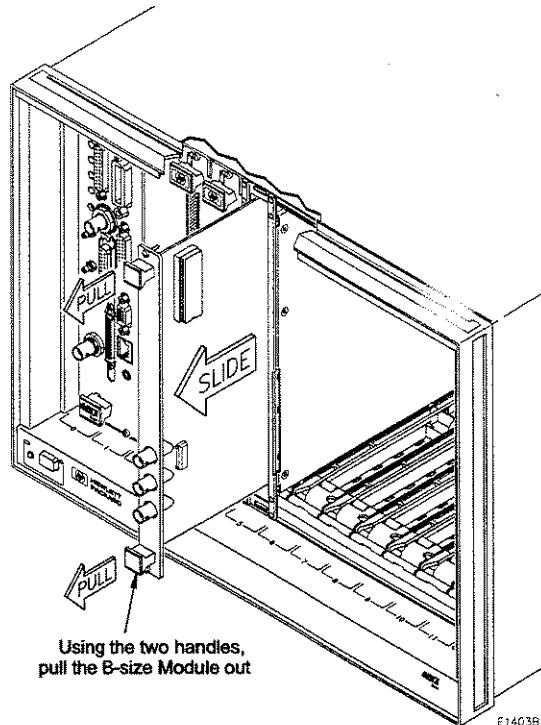

3 Using the "D" Ring, pull the C-Size Adapter Module out of the Mainframe.

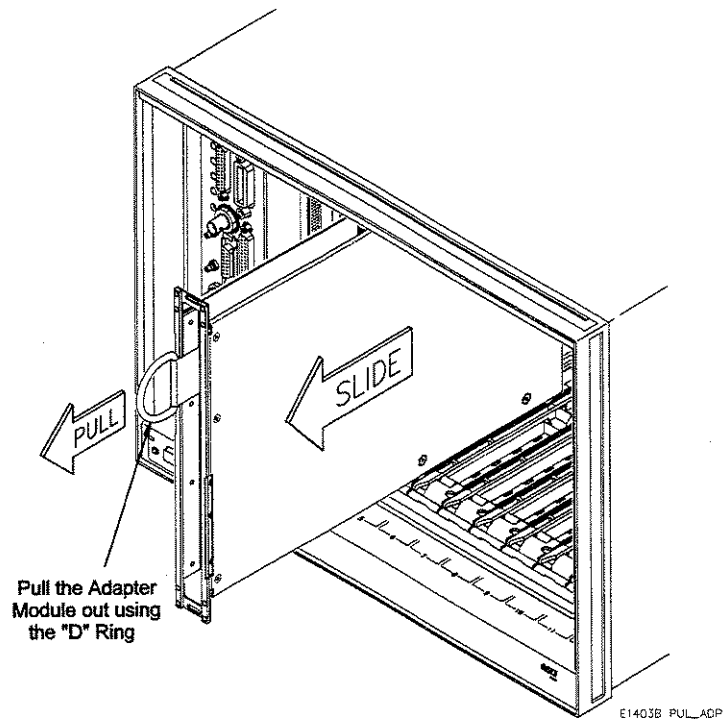

Chapter 3

Using the Adapters

This chapter shows how to use the adapter modules. It includes a block diagram for both the HP E1403C and HP E1407A Adapter Modules as well as connector pinouts. This chapter also includes, for the HP E1407A Adapter Module, instructions on how to use and install the J2 connector cable, how to select the direction (to or from the mainframe's backplane) of the trigger signals on the ECL and TTL trigger lines, and how to select unbuffered or buffered SUMBUS connections.

HP E1403C Block Diagram

Figure 3-1 shows the block diagram for the HP E1403C C-Size Adapter Module.

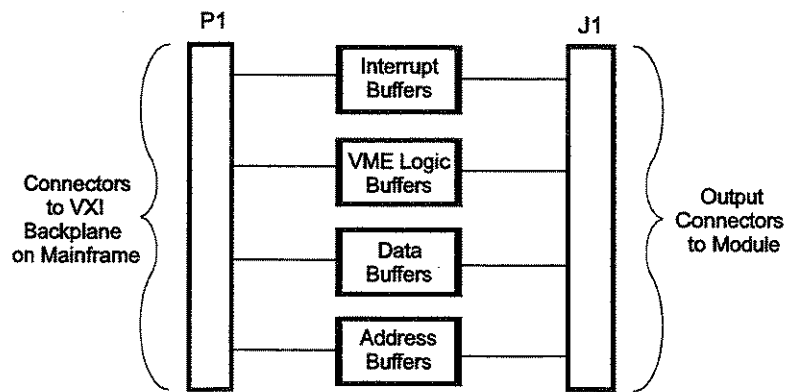

Figure 3-1. HP E1403C Block Diagram

HP E1403C Connector Pinout

Figure 3-2 shows the P1 and J1 connector's pinout for the HP E1403C Adapter Module.

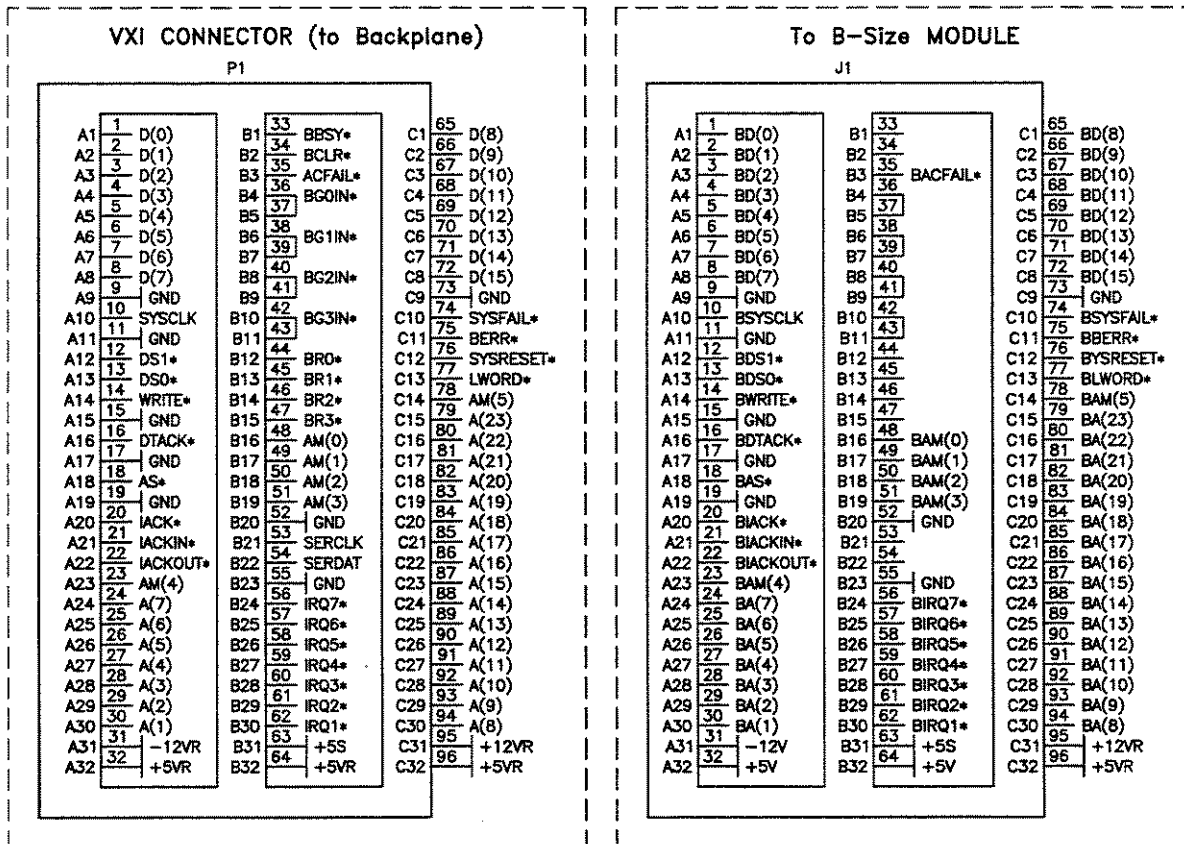

Figure 3-2. HP E1403C P1 and J1 Connector Pinout

HP E1407A Block Diagram

Figure 3-3 shows the block diagram for the HP E1407A C-Size Adapter Module.

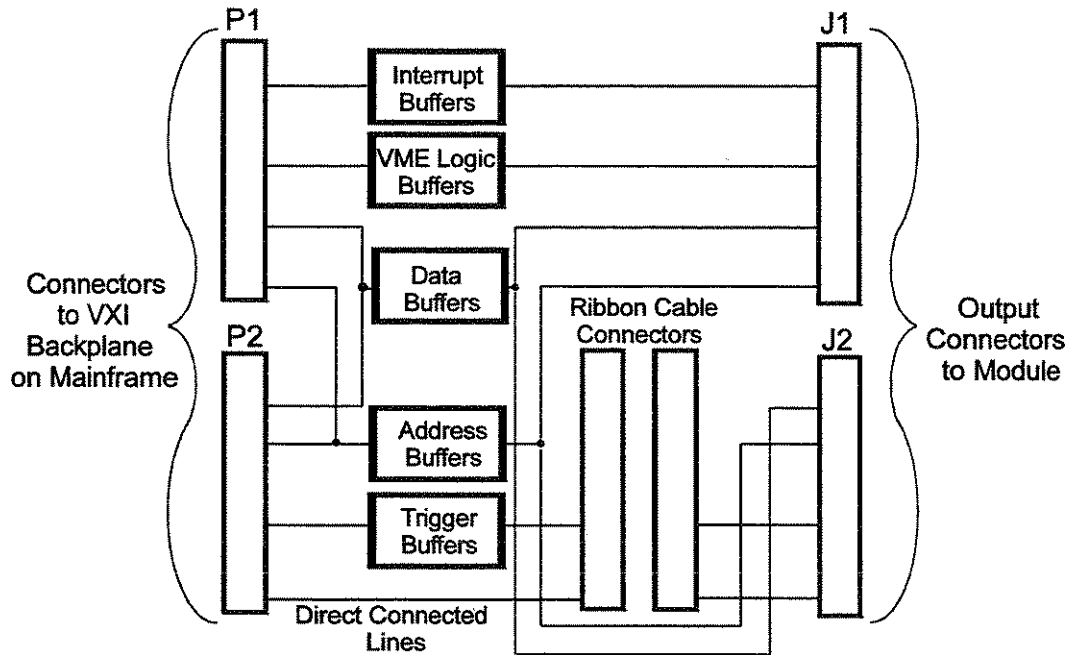

Figure 3-3. HP E1407A Block Diagram

HP E1407A Connector Pinout

Figure 3-4 shows the P1 and J1 connector's pinout, and Figure 3-5 shows the P2 and J2 connector's pinout for the HP E1407A Adapter Module.

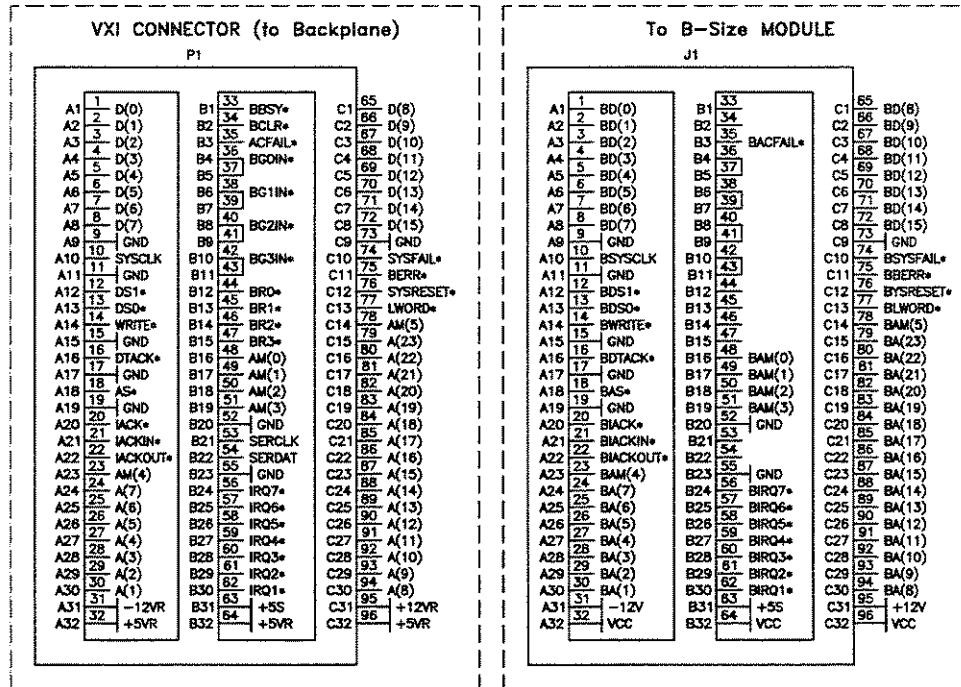

Figure 3-4. HP E1407A P1 and J1 Connector Pinout

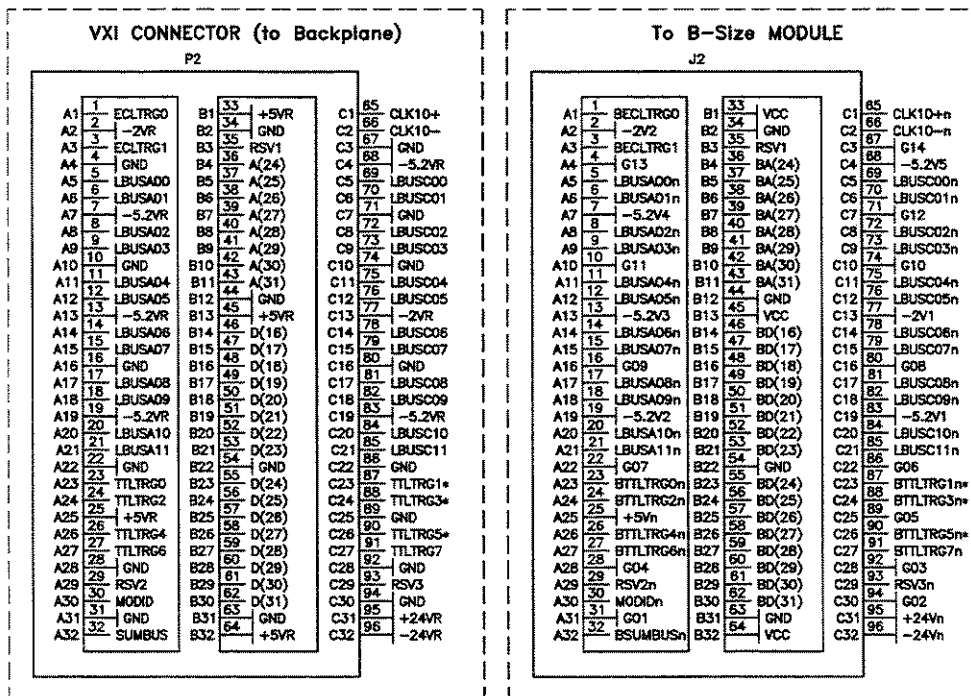

Figure 3-5. HP E1407A P2 and J2 Connector Pinout

Installing the J2 Connector Cable (HP E1407A Only)

Purpose of the J2 Cable

The HP E1407A C-Size Adapter Module is shipped with a long and short J2 Connector Cables. The long J2 cable allows for direct access to the outer rows of the J2 connector of the B-Size module (that is, VMEbus modules that utilize the outer rows of J2) inside the adapter module. The short J2 cable makes internal connections between the P2 and J2 connectors of the adapter module to allow for connections between the J2 connector of the B-Size module inside the adapter module and the P2 connector of the mainframe. Use this for VXIbus modules that utilize the outer rows of J2. If your module has no outer row connections of J2, do not install either cable.

See Figure 3-6 for the J2 connector's pinout diagram.

Caution Damage to a VMEbus module, adapter module, mainframe, or all three may result if using the short cable in an adapter module with a VMEbus module.

Install the J2 Cable Do the following to install either J2 Cable:

- 1** On the C-Size VXIbus Adapter Module, remove the 7 Top Shield Retainer Screws and Top Shield.

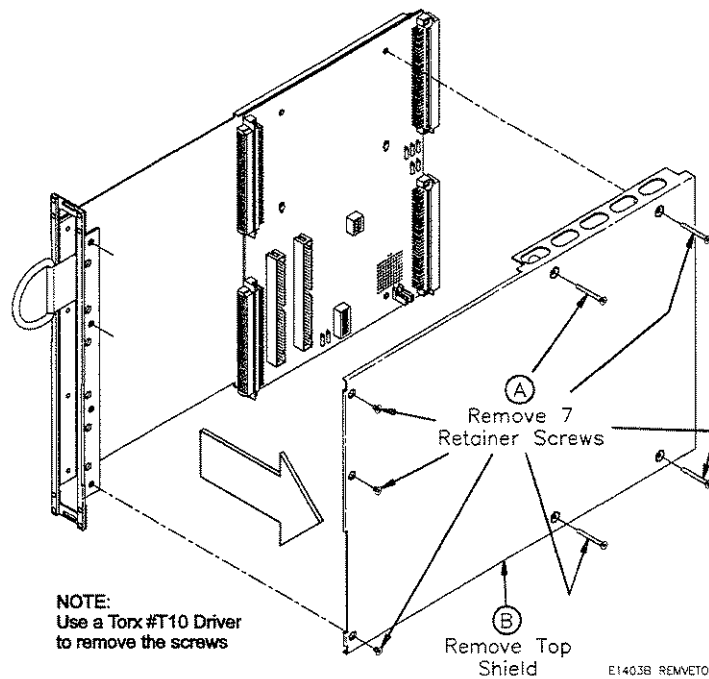

2 Plug in either the Short or Long Ribbon (J2) Cable.

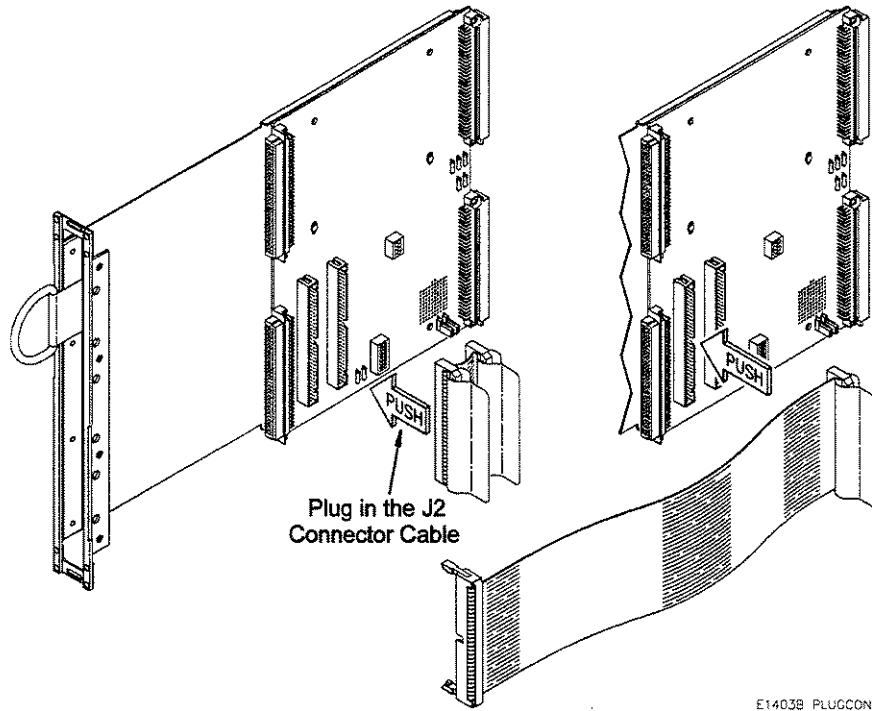

3 Reinstall the Top Shield and Retainer Screws on the C-Size Adapter Module.

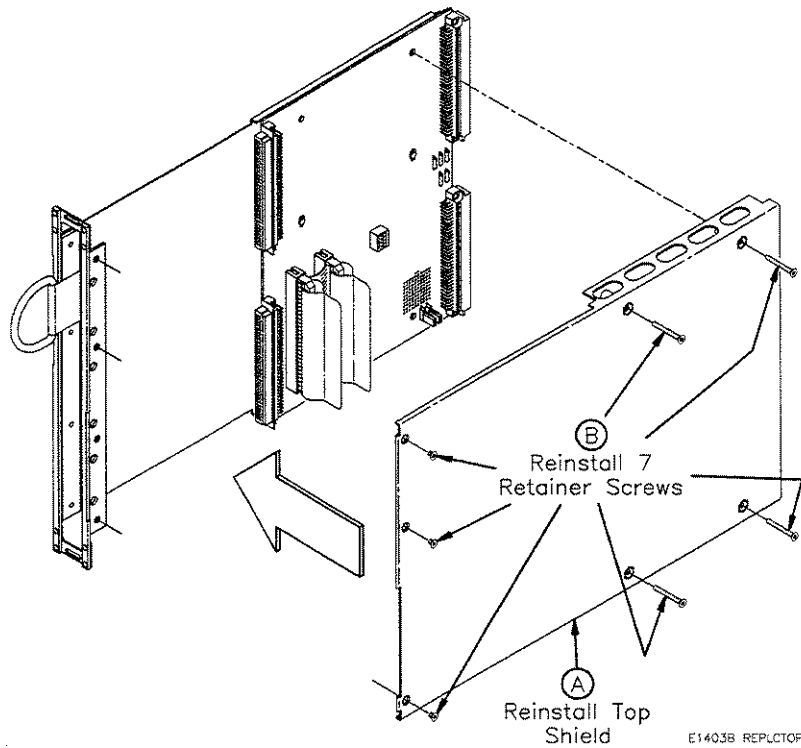

Ribbon Cable (J2) Connector Pinout

Figure 3-6 shows the pinout for the HP E1407A ribbon cable connectors (J2).

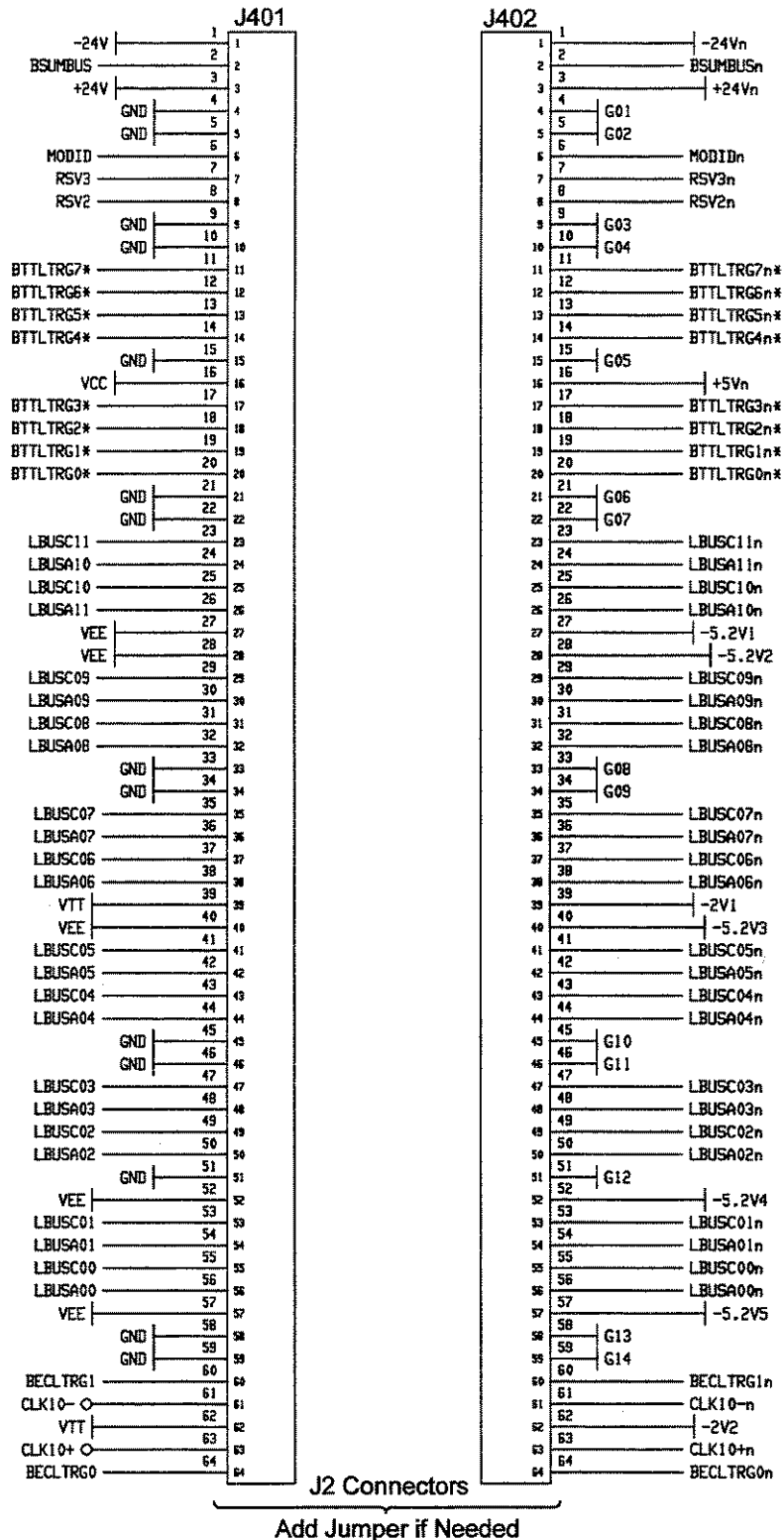
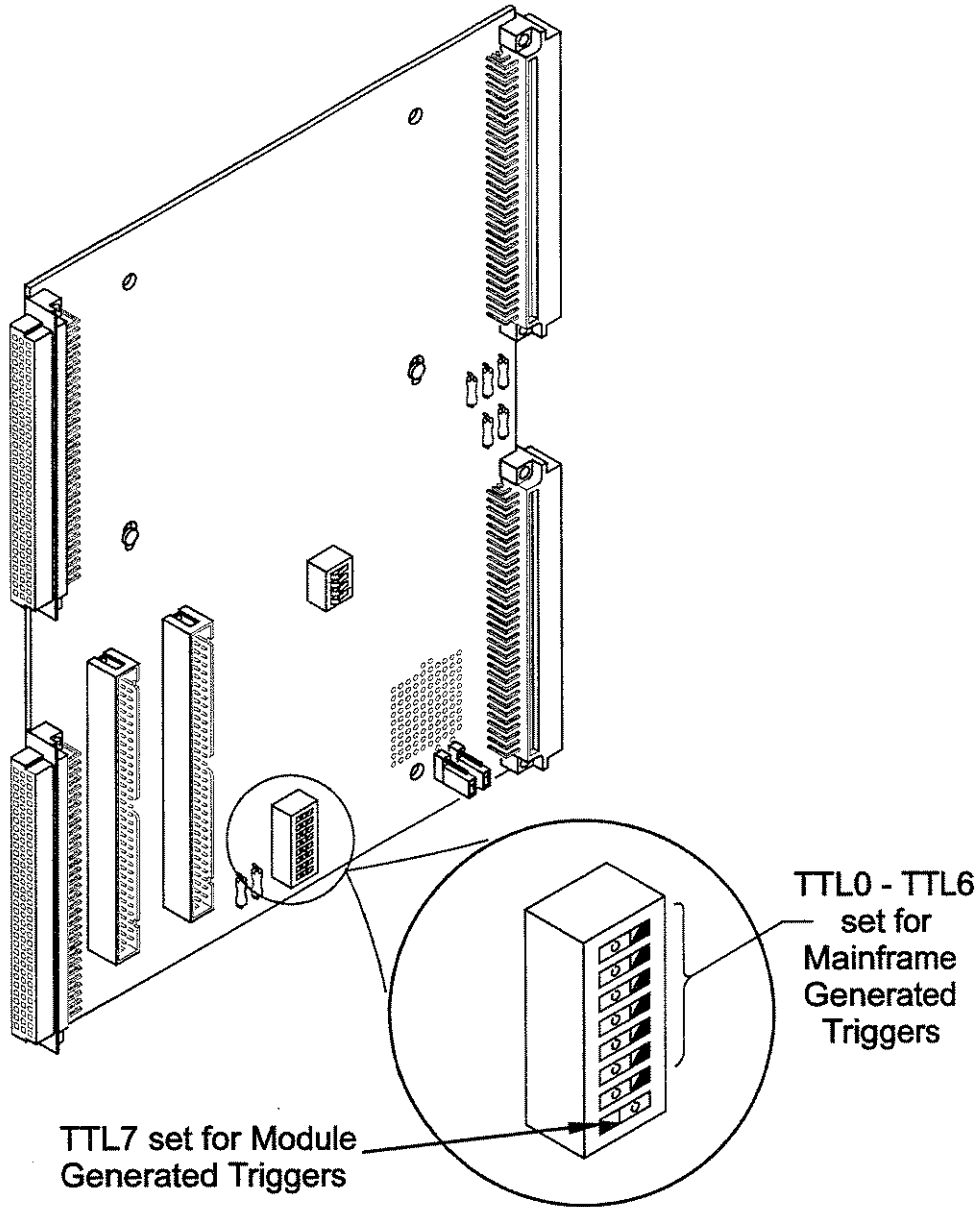

Figure 3-6. HP E1407A Ribbon Cable Connectors (J2)

Selecting the TTL Trigger Direction (HP E1407A Only)

The HP E1407A C-Size Adapter Module has a switch that allows you to set the trigger signal direction of the TTL0–TTL7 Trigger Lines. Figure 3-7 shows that the TTL7 Trigger Signal comes from the B-Size Module, and TTL0–TTL6 from the Mainframe's VXI Backplane. Use the illustration as a guide to set the appropriate trigger directions for your application.



E1403B 1407_SW8

Figure 3-7. Selecting the TTL Trigger Signal Direction

Selecting the ECL Trigger Direction (HP E1407A Only)

The HP E1407A C-Size Adapter Module has a switch that allows you to set the trigger signal direction of the ECL0 and ECL1 Trigger Lines. Figure 3-8 shows that the ECL1 Trigger Signal comes from the B-Size Module, and ECL0 from the Mainframe's VXI Backplane. Use the illustration as a guide to set the appropriate trigger directions for your application.

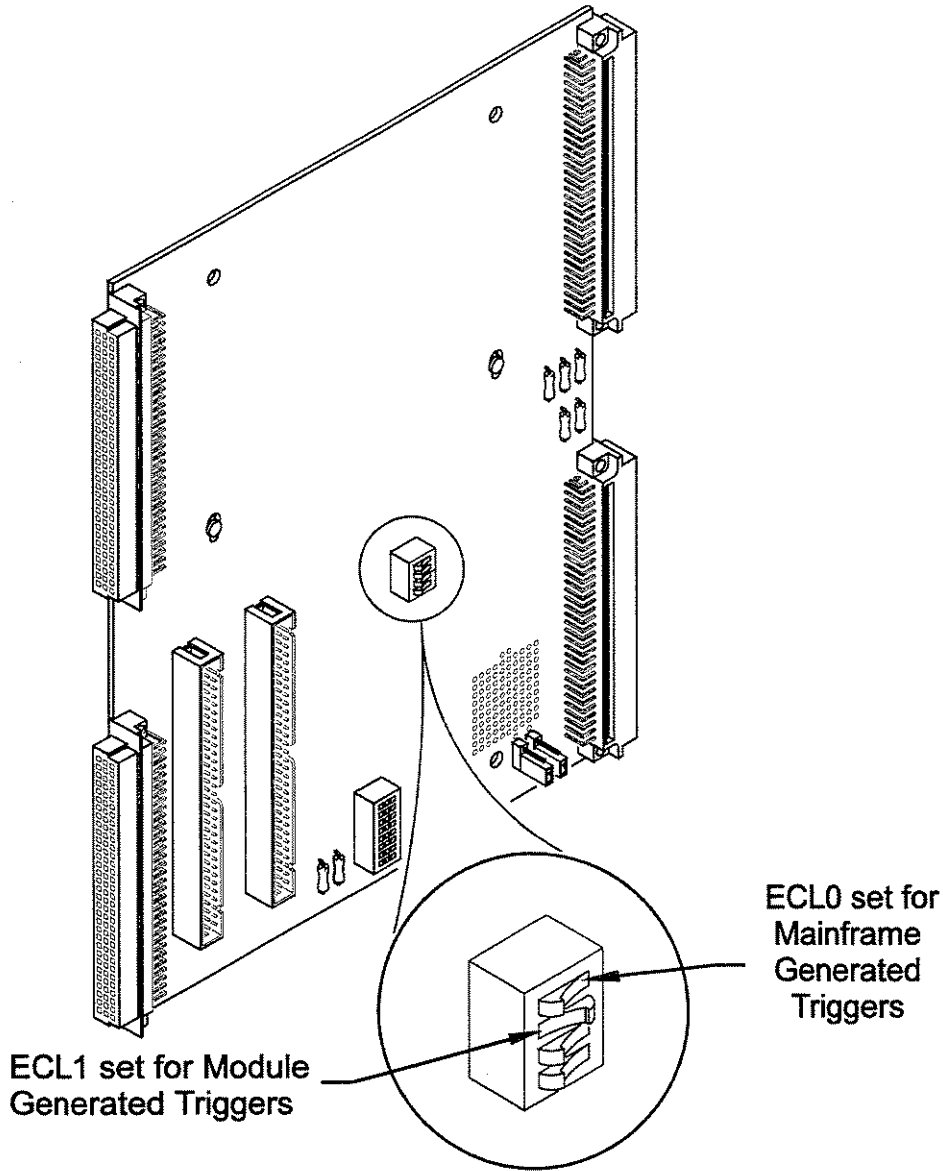

E1403B 1407_SW

Figure 3-8. Selecting the ECL Trigger Signal Direction

SUMBUS Configurations (HP E1407A Only)

Disconnecting the SUMBUS

The ribbon cable and a pair of jumpers connect the SUMBUS to the output connectors (i.e., to the B-Size Module). Use Figure 3-9 to disconnect (i.e., remove the jumpers) or connect the SUMBUS.

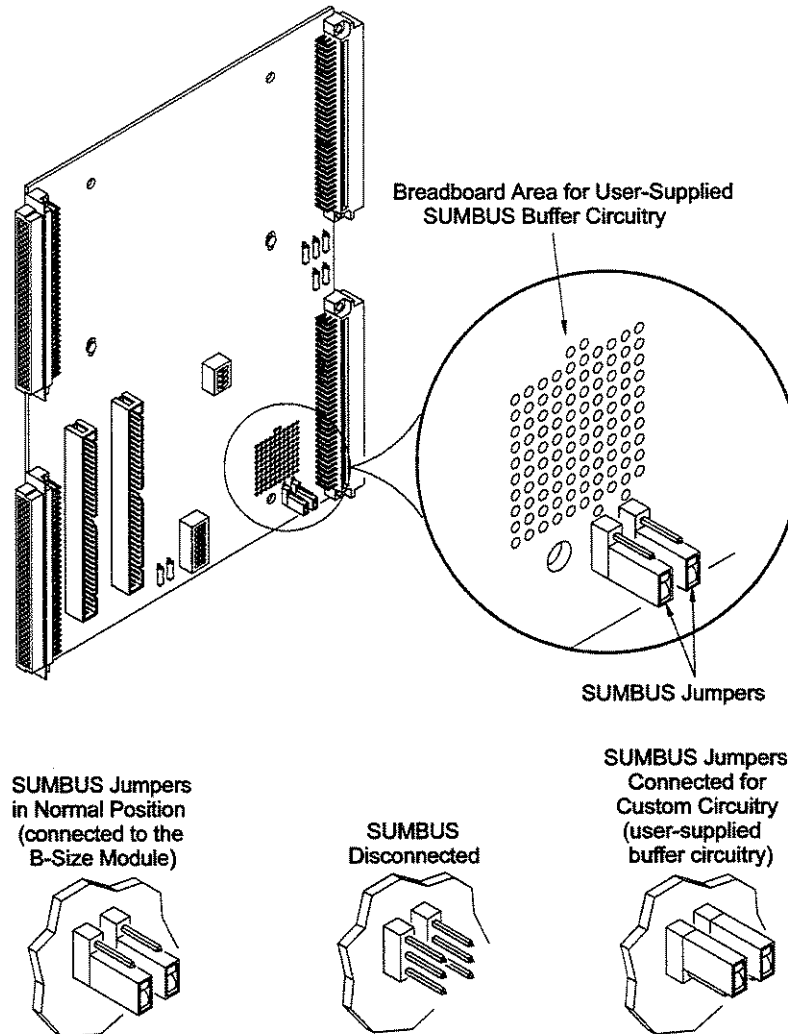

Figure 3-9. SUMPBUS Jumper Configurations

Adding Buffer Circuitry to the SUMPBUS

The adapter module has no circuitry available to buffer the SUMPBUS. However, there is a breadboard area on the PC board in the HP E1407A Adapter that allows you to add your own circuitry (e.g., op-amps) to provide buffering for the SUMPBUS. The breadboard area also includes connections to the ± 12 V Power Supplies.

You can add buffer circuitry either for SUMPBUS signals coming from the B-Size Module in the Adapter Module or from the Mainframe's VXI Backplane. Use Figure 3-9 to select the appropriate jumpers for your application, and to locate the breadboard area.

Appendix A

HP E1403C and HP E1407A Specifications

Product Characteristics

- P1 and P2 extension fully buffered (P1 only on HP E1403C).
- Slave-only capability; cannot be used in Slot 0 with bus masters.
- Unlimited number of adapters per mainframe.
- 1-slot wide.
- Option 10 is 2-slot wide. Only the P1 and/or P2 connectors of a single slot are used.
- Replacement fuses are subminiature 4A, 125V (Littelfuse is recommended).

Power Requirements

<u>Voltage:</u>	<u>+5V</u>	<u>+12V*</u>
Peak Module Current (A):	0.10	0.07
Dynamic Module Current (A):	0.01	0.01

* HP E1407A Only

Cooling Requirements

0.02mm H₂O @0.10Liter/sec Air Flow for 10°C rise.

Notes:

A

- Adapter Description, 9
 - HP E1403C, 9
 - HP E1407A, 10
 - option 10, 9
- Adding SUMBUS Buffer Circuitry, 26
- A-Size VMEbus Modules, installing, 11

B

- Backplane
 - ECL trigger signals, 25
 - SUMBUS buffer circuitry, 26
 - TTL trigger signals, 24
- Block Diagram
 - HP E1403C, 17
 - HP E1407A, 19
- B-Size VXIbus Modules
 - ECL trigger signal, 25
 - installing, 12–14
 - removing, 15–16
 - SUMBUS buffer circuitry, 26
 - TTL trigger signal, 24

C

- Cable
 - ribbon cable (J2)
 - description, 21
 - installing, 21, 23
 - pinouts, 23
- Certification, 3
- Connecting the SUMBUS, 26
- Cooling Requirements, 27

D

- Declaration of Conformity, 5
- Description
 - adapters, 9
 - HP E1403C, 9
 - HP E1407A, 10
 - ECL trigger, 25
 - ribbon cable (J2), 21, 23
 - SUMBUS, 26
 - TTL trigger, 24

- Description (*continued*)
 - option 10, 9
 - ribbon cable (J2), 21, 23
- Disconnecting the SUMBUS, 26
- Documentation History, 4

E

- ECL Trigger Direction, 25

F

- Fuses, 27

H

- HP E1403C
 - A-size VMEbus modules, installing, 11
 - block diagram, 17
 - B-size VXIbus modules
 - installing, 12–14
 - removing, 15–16
 - description, 9
 - pinout, 18
 - specifications, 27
- HP E1407A
 - block diagram, 19
 - B-size VXIbus modules
 - ECL trigger signals, 25
 - installing, 12–14
 - removing, 15–16
 - SUMBUS buffer circuitry, 26
 - TTL trigger signals, 24
 - description, 10
 - ECL trigger direction, 25
 - pinout, 20
 - ribbon cable (J2), 23
 - ribbon cable (J2), installing, 21, 23
 - specifications, 27
 - SUMBUS, 26
 - TTL trigger direction, 24

I

Installation

- and removal instructions, 11
- A-size VMEbus modules, 11
- B-size VXIbus modules, 12–14
- HP E1407A, ribbon cable (J2), 21, 23
- preparation, 11

M

Mainframe

- backplane
 - ECL trigger signals, 25
 - SUMBUS buffer circuitry, 26
 - TTL trigger signals, 24
- installing
 - A-size VMEbus modules, 11
 - B-size VXIbus modules, 12–14
- removing modules from, 15–16

O

- Option 10, description, 9

P

Pinouts

- HP E1403C, 18
- HP E1407A, 20
 - ribbon cable (J2), 23
- Power Requirements, 27
- Preparing for Installation, 11

R

- Removing B-size VXIbus Modules, 15–16
- Ribbon Cable (J2)
 - description, 21
 - installing, 21, 23
 - pinouts, 23

S

- Safety Warnings, 4
- Selecting
 - ECL trigger direction, 25
 - TTL trigger direction, 24
- Specifications, 27
- SUMBUS
 - adding buffer circuitry, 26
 - configurations, 26

Switches

- ECL trigger, 25
- TTL trigger, 24

T

Triggers

- B-size modules, 24–25
- ECL, 25
- mainframe VXI backplane, 24–25
- TTL, 24
 - trigger direction, 24

U

- Using the Adapters, 17

V

- VXIplug&play* Example Programs
 - See *VXIplug&play* Online Help
- VXIplug&play* Function Reference
 - See *VXIplug&play* Online Help
- VXIplug&play* Programming
 - See *VXIplug&play* Online Help
- VXIplug&play* Soft Front Panel
 - See *VXIplug&play* Online Help

W

- WARNINGS, 4





