

HP 75000 SERIES C

**High-Power Mainframe
HP E1401A**

User's/Service Manual



Copyright© Hewlett-Packard Company, 1992

Manual Part Number: E1401-90003
Microfiche Part Number: E1401-99003

Printed: October 1992 Edition 2
Printed in U.S.A.

CERTIFICATION

Hewlett-Packard Company certifies that this product met its published specifications at the time of shipment from the factory. Hewlett-Packard further certifies that its calibration measurements are traceable to the United States National Institute of Standards and Technology (formerly National Bureau of Standards), to the extent allowed by that organization's calibration facility, and to the calibration facilities of other International Standards Organization members.

WARRANTY

This Hewlett-Packard product is warranted against defects in materials and workmanship for a period of three years from date of shipment. Duration and conditions of warranty for this product may be superseded when the product is integrated into (becomes a part of) other HP products. During the warranty period, Hewlett-Packard Company will, at its option, either repair or replace products which prove to be defective.

For warranty service or repair, this product must be returned to a service facility designated by Hewlett-Packard (HP). Buyer shall prepay shipping charges to HP and HP shall pay shipping charges to return the product to Buyer. However, Buyer shall pay all shipping charges, duties, and taxes for products returned to HP from another country.

HP warrants that its software and firmware designated by HP for use with a product will execute its programming instructions when properly installed on that product. HP does not warrant that the operation of the product, or software, or firmware will be uninterrupted or error free.

LIMITATION OF WARRANTY

The foregoing warranty shall not apply to defects resulting from improper or inadequate maintenance by Buyer, Buyer-supplied products or interfacing, unauthorized modification or misuse, operation outside of the environmental specifications for the product, or improper site preparation or maintenance.

The design and implementation of any circuit on this product is the sole responsibility of the Buyer. HP does not warrant the Buyer's circuitry or malfunctions of HP products that result from the Buyer's circuitry. In addition, HP does not warrant any damage that occurs as a result of the Buyer's circuit or any defects that result from Buyer-supplied products.

NO OTHER WARRANTY IS EXPRESSED OR IMPLIED. HP SPECIFICALLY DISCLAIMS THE IMPLIED WARRANTIES OF MERCHANTABILITY AND FITNESS FOR A PARTICULAR PURPOSE.

EXCLUSIVE REMEDIES

THE REMEDIES PROVIDED HEREIN ARE BUYER'S SOLE AND EXCLUSIVE REMEDIES. HP SHALL NOT BE LIABLE FOR ANY DIRECT, INDIRECT, SPECIAL, INCIDENTAL, OR CONSEQUENTIAL DAMAGES, WHETHER BASED ON CONTRACT, TORT, OR ANY OTHER LEGAL THEORY.

NOTICE

The information contained in this document is subject to change without notice. HEWLETT-PACKARD (HP) MAKES NO WARRANTY OF ANY KIND WITH REGARD TO THIS MATERIAL, INCLUDING, BUT NOT LIMITED TO, THE IMPLIED WARRANTIES OF MERCHANTABILITY AND FITNESS FOR A PARTICULAR PURPOSE. HP shall not be liable for errors contained herein or for incidental or consequential damages in connection with the furnishing, performance or use of this material. This document contains proprietary information which is protected by copyright. All rights are reserved. No part of this document may be photocopied, reproduced, or translated to another language without the prior written consent of Hewlett-Packard Company. HP assumes no responsibility for the use or reliability of its software on equipment that is not furnished by HP.

Restricted Rights Legend

Use, duplication, or disclosure by the Government is subject to restrictions as set forth in subdivision (b)(3)(ii) of the Rights in Technical Data and Computer Software clause at 52.227-7013. Hewlett-Packard Company; 3000 Hanover Street; Palo Alto, California 94304

Declaration of Conformity

According to ISO/IEC Guide 22 and EN 45014

The Hewlett-Packard Company declares that the HP E1401A conforms to the following Product Specifications.

Safety: IEC 348
CSA C22.2 #231
UL 1244

EMC: CISPR 11:1990/EN 55011 (1991): Group 1 Class A
IEC 801-2:1991/EN 50082-1 (1992): 4kVCD, 8kVAD
IEC 801-3:1984/EN 50082-1 (1992): 3 V/m
IEC 801-4:1988/EN 50082-1 (1992): 1kV

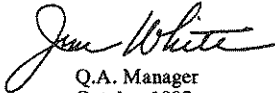
Q.A. Manager
October 1992

Hewlett-Packard Company
P.O. Box 301
815 14th Street S.W.
Loveland, Colorado 80539 U.S.A

Printing History

The Printing History shown below lists all Editions and Updates of this manual and the printing date(s). The first printing of the manual is Edition 1. The Edition number increments by 1 whenever the manual is revised. Updates, which are issued between Editions, contain replacement pages to correct the current Edition of the manual. Updates are numbered sequentially starting with Update 1. When a new Edition is created, it contains all the Update information for the previous Edition. Each new Edition or Update also includes a revised copy of this printing history page. Many product updates or revisions do not require manual changes and, conversely, manual corrections may be done without accompanying product changes. Therefore, do not expect a one-to-one correspondence between product updates and manual updates.

Edition 1 (Part Number E1401-90001) June 1992

Edition 2 (Part Number E1401-90003) October 1992

Safety Symbols



Instruction manual symbol affixed to product. Indicates that the user must refer to the manual for specific Warning or Caution information to avoid personal injury or damage to the product.



Indicates the field wiring terminal that must be connected to earth ground before operating the equipment—protects against electrical shock in case of fault.



OR Frame or chassis ground terminal—typically connects to the equipment's metal frame.



Alternating current (AC).



Direct current (DC).



Indicates hazardous voltages.

WARNING

Calls attention to a procedure, practice, or condition that could cause bodily injury or death.

CAUTION

Calls attention to a procedure, practice, or condition that could possibly cause damage to equipment or permanent loss of data.

WARNINGS

The following general safety precautions must be observed during all phases of operation, service, and repair of this product. Failure to comply with these precautions or with specific warnings elsewhere in this manual violates safety standards of design, manufacture, and intended use of the product. Hewlett-Packard Company assumes no liability for the customer's failure to comply with these requirements.

Ground the equipment: For Safety Class 1 equipment (equipment having a protective earth terminal), an uninterruptible safety earth ground must be provided from the mains power source to the product input wiring terminals or supplied power cable.

DO NOT operate the product in an explosive atmosphere or in the presence of flammable gases or fumes.

For continued protection against fire, replace the line fuse(s) only with fuse(s) of the same voltage and current rating and type. DO NOT use repaired fuses or short-circuited fuse holders.

Keep away from live circuits: Operating personnel must not remove equipment covers or shields. Procedures involving the removal of covers or shields are for use by service-trained personnel only. Under certain conditions, dangerous voltages may exist even with the equipment switched off. To avoid dangerous electrical shock, DO NOT perform procedures involving cover or shield removal unless you are qualified to do so.

DO NOT operate damaged equipment: Whenever it is possible that the safety protection features built into this product have been impaired, either through physical damage, excessive moisture, or any other reason, REMOVE POWER and do not use the product until safe operation can be verified by service-trained personnel. If necessary, return the product to a Hewlett-Packard Sales and Service Office for service and repair to ensure that safety features are maintained.

DO NOT service or adjust alone: Do not attempt internal service or adjustment unless another person, capable of rendering first aid and resuscitation, is present.

DO NOT substitute parts or modify equipment: Because of the danger of introducing additional hazards, do not install substitute parts or perform any unauthorized modification to the product. Return the product to a Hewlett-Packard Sales and Service Office for service and repair to ensure that safety features are maintained.

HP 75000 Series C Documentation

Suggested Sequence for Using the Manuals

C-Size VXIbus Systems Installation and Getting Started Guide. Contains step-by-step instructions for all aspects of plug-in module and mainframe installation.

HP E1401A High-Power Mainframe User's Manual. Contains information on how to set up, operate, and care for your HP E1401 High-Power Mainframe.

Plug-In Module User's Manuals. Contain programming and configuration information for the plug-in modules. These manuals contain examples for the most commonly-used functions and give a complete SCPI command reference for the module.

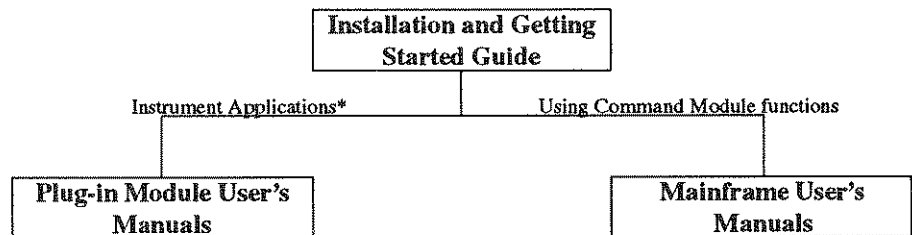

* For Scanning Voltmeter Applications, refer to the HP E1326 and HP E1411 5 1/2 Digit Multimeter User's Manual.

Suggested Sequence for Using the Manuals

Related Documents

HP E1406A Command Module User's Manual. Contains information on downloading user tables to modify (if necessary) configurations set up using the *Installation and Getting Started Guide*, information on using an RS-232 terminal as a "front panel" to your C-size system, and information on how interrupts are used. A command reference for the HP E1406 Command Module is included.

HP Instrument BASIC User's Handbook. Includes three books: *HP Instrument BASIC Programming Techniques*, *HP Instrument BASIC Interfacing Techniques*, and *HP Instrument BASIC Language Reference*.

Using HP Instrument BASIC with the E1406 Command Module. Contains information on the version of HP Instrument Basic which can be installed in your HP E1406 Command Module.

Beginner's Guide to SCPI. Explains the fundamentals of programming instruments using the Standard Commands for Programmable Instruments (SCPI) language. We recommend this guide to anyone who is programming with SCPI for the first time.

Tutorial Description of the Hewlett-Packard Interface Bus. Describes the technical fundamentals of the Hewlett-Packard Interface Bus (HP-IB). This document also includes general information on IEEE 488.2 Common Commands. We recommend this document to anyone who is programming with IEEE 488.2 for the first time.

IEEE Standard 488.2-1987, IEEE Standard Codes, Formats, Protocols, and Common Commands. Describes the underlying message formats and data types used in SCPI and defines Common Commands. You will find this document useful if you need to know the precise definition of certain message formats, data types, or Common Commands. Available from: The Institute of Electrical and Electronic Engineers, Inc.; 345 East 47th Street; New York, NY 10017; U.S.A.

VXIbus System Specifications. Available from Hewlett-Packard.

The VMEbus Specification. Available from: VMEbus International Trade Association; 10229 N. Scottsdale Road, Suite E; Scottsdale, AZ 85253; U.S.A.

About this Manual

Manual Content

This manual contains information on the applications of the HP E1401 High-Power Mainframe. The manual is part of a manual set that includes the C-Size VXTbus Systems "Installation and Getting Started Guide" and various plug-in module user's manuals.

Chapter 1: Product Overview

This chapter introduces you to the HP 75000 Series C Model E1401 High-Power Mainframe and gives an overview of its features. It also shows how to get the correct power to the mainframe.

Chapter 2: Mainframe Hardware Description

This chapter gives a detailed description of the mainframe hardware, its backplane provisions, the cooling system, and shows how to install plug-in modules.

Chapter 3: Using the Mainframe Power Supplies and Auxiliary Connector

This chapter gives detailed information on use of the High-Power Mainframe's seven power supplies, and the various signals that can be accessed through the auxiliary connector on the rear of the power supply.

Appendix A: Specifications

This appendix contains operating specifications for the High-Power Mainframe.

Appendix B: Replaceable Parts & Modules

This appendix shows the replaceable parts and modules in the High-Power Mainframe, along with their HP part numbers. It also shows procedures for removing the major modules in the mainframe.

HP E1401A Safety Grounding Information

WARNING

For protection from electrical shock when operating at mains frequencies greater than 66Hz, connect the chassis ground terminal to permanent earth ground.

Avertissement.

Risque de choc électrique. Si la fréquence du secteur est supérieure à 66 Hz, relier la borne de masse du châssis à une prise de terre fixe.

Grounding Procedure

Connect a 16 AWG (1.3mm^2 or larger), wire to the PEM nut shown in Figure 1. The wire must be green with a yellow stripe or bare. Use an M4 x 10 screw, grounding lug, and toothed washers (or toothed lug) as shown in Figure 2. Attach the other end of the wire to permanent earth ground using toothed washers or a toothed lug.

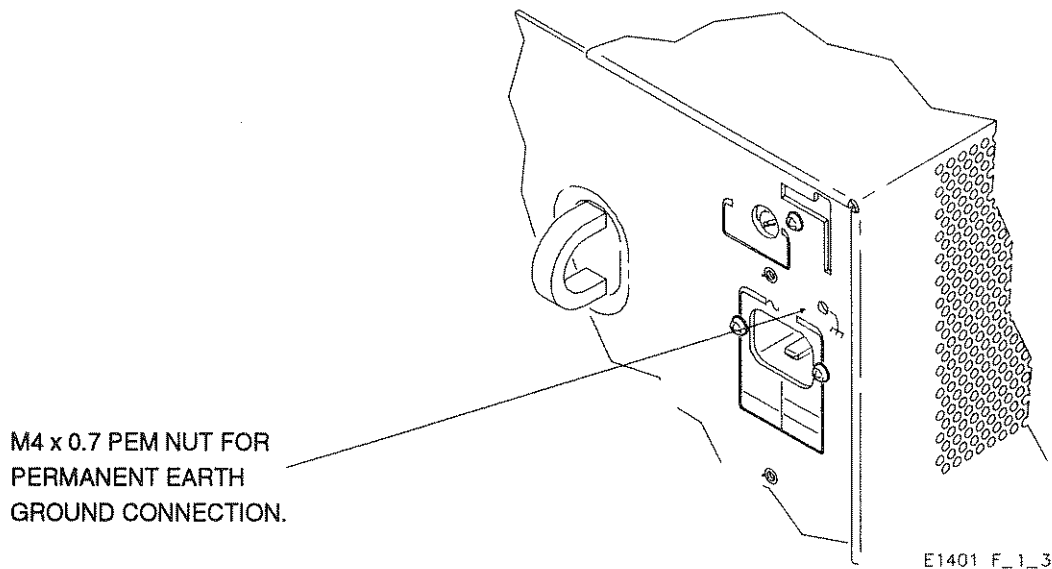

Figure 1. Grounding Connection

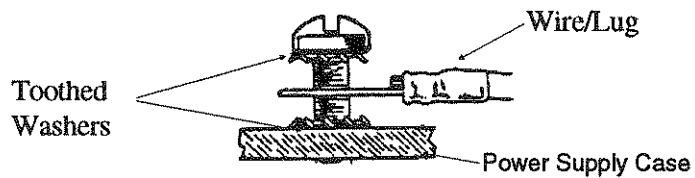

Figure 2. Grounding screw, toothed washers

WARNING

The front panel switch on this unit does not disconnect all power from internal circuits. Unplug power cord before opening this unit.

Avertissement.

L'interrupteur frontal de cet appareil ne met pas tous les circuits internes hors tension. Débrancher le cordon d'alimentation avant d'ouvrir cet appareil.

Table of Contents

Chapter 1. Getting Started

Using this Chapter	1-1
Mainframe Description	1-1
Setting the Line Voltage	1-2
Installing the Line Power Fuse	1-2
Power Cords	1-3
Power Cord Bracket	1-4

Chapter 2. Mainframe Hardware Description

About this Chapter	2-1
Backplane Description	2-1
Mainframe Cooling System Description	2-2
Requirements for Modules	2-4
Installing Modules	2-5
Plug-in Module Selection and Special Design	2-6
Using Chassis Shield and Backplane Connector Shields	2-7
Using Faceplate Panels	2-7
Rack Mounting the Mainframe	2-7

Chapter 3. Power Supplies and Auxiliary Connector

About this Chapter	3-1
Maximum Power Ratings	3-1
Backplane Voltage Pinouts	3-2
Using Power Supply Outputs	3-2
Rear Panel Auxiliary Connector	3-3

Appendix A. Specifications

Appendix B. Replaceable Parts & Modules

About this Appendix	B-1
Recommended Service Procedures	B-1
Replaceable Parts Lists	B-2
Removing the Power Supply Fan Filter	B-12
Removing the Mainframe Fan Filters	B-12
Removing the Power Supply	B-13
Removing the Power Supply Fan	B-15
Removing the Mainframe Fan Assembly	B-16
Replacing a Lower Plastic Module Guide	B-17
Replacing an Upper Plastic Module Guide	B-19



Getting Started

Using this Chapter

This chapter will help you get the mainframe ready for operation. It contains the following sections:

- Mainframe Description 1-1
- Setting the Line Voltage 1-2
- Installing the Line Power Fuse 1-2
- Power Cords 1-2

Mainframe Description

The HP E1401 High-Power Mainframe is designed in full compliance with the VXIbus Specification (Revision 1.4) and VMEbus System Specification (Revision C.1). It contains 13 slots for plug-in modules in a compact 310.4 mm (12.22 in.) of vertical rack space. You can rack mount the mainframe in the forward or reverse position.

The mainframe is designed to provide the quiet EMC environment needed to support a multi-vendor VXIbus instrumentation system. It has the following main features:

- Single-piece card/air guides to provide smoother insertion of modules and minimize air leakage from the cooling plenum.
- Solid state automatic bus grant sensing to bypass empty slots
- Variable-speed fan cooling
- Rear mounted 25-pin sub-D connector for auxilliary power supply function access.
- Easy replacement of major components - most of which can be replaced from the rear of the mainframe, even while the mainframe is mounted in a rack.
- Seven standard VXIbus power supplies - all overvoltage, overcurrent, and temperature protected.
- Supports high-performance instruments with a total of 650 Watts cooling capacity, assuming 10° C internal rise.

Setting the Line Voltage

The HP E1401 High-Power Mainframe includes a power supply which automatically senses and adjusts for line voltages between 100/120 VAC and 220/240 VAC, and power line frequencies between 48 Hz and 66 Hz.

WARNING

For protection from electrical shock when operating at power line frequencies > 66Hz, connect the chassis ground terminal to earth ground. See "Safety Grounding" in the front of this manual for details.

Avertissement.

Risque de choc électrique. Si la fréquence du secteur est supérieure à 66 Hz, relier la borne de masse du châssis à une prise de terre fixe.

Installing the Line Power Fuse

The mainframe is shipped with a 15A fast blow (15AF) fuse (HP part number 2110-0054) already installed. This fuse is suitable for all line voltage ratings. Figure 1-1 shows how to install a new fuse if necessary.

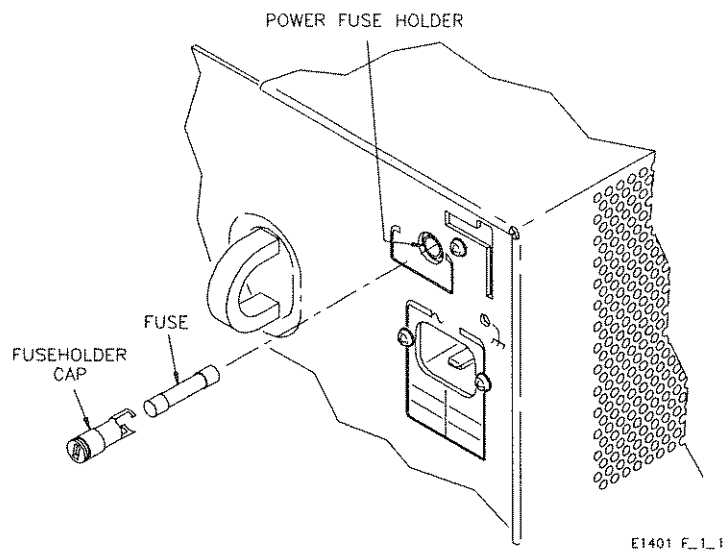

Figure 1-1. Installing a Fuse

WARNING

For continued protection against fire hazard, replace fuse only with fuse of specified type and current rating.

AVERTISSEMENT

Pour ne pas compromettre la protection contre le risque d'incendie, remplacer le fusible par un fusible de mêmes type et courant nominal.

Power Cords

Table 1-1 shows the various mainframe power cords and their Hewlett-Packard part numbers. If you received the wrong power cord, notify your HP Sales Office for replacement.

NOTE

These are special high power cords. You should make sure that any replacement cords you purchase are capable of handling the indicated loads.

Table 1-1. Power Cords for the HP E1401

Country	Part Number	Volts	Rated Amps	Type
U.K.	8120-5392	250 VAC	10A	Right Angle Connector
Australia	8120-5393	250 VAC	10A	Right Angle Connector
Europe	8120-5394	250 VAC	10A	Right Angle Connector
*U.S./Canada	8120-5395	125 VAC	13A	Right Angle Connector
Switzerland	8120-5397	250 VAC	10A	Right Angle Connector
Denmark	8120-5398	250 VAC	10A	Right Angle Connector
Japan	8120-5400	125 VAC	15A	Right Angle Connector

Power cords supplied by HP have polarities matched to the power input socket on the instrument:

L= Line or Active Conductor (also called "live" or "hot")

N= Neutral or Identified Conductor

E= Earth or Safety Ground

NOTE:

* CSA certification includes only this power cord.

E1401 F_1_2

WARNING

For protection from electric shock hazard, power cord ground must not be defeated.

The front power switch on this unit does not disconnect all power from internal circuits. In case of emergency, the operator may need to disconnect power to this unit. Do not block the operator's access to the power cord, or (if installed in a rack) to the circuit breaker which supplies power to this unit.

If a remote standby switch is connected to this unit by way of the rear panel 25-pin Sub D connector, then the operator may not be able to turn this unit off by using the front panel switch. Notify the operator of the location of the disconnect device (either the power cord or a circuit breaker) for this unit.

AVERTISSEMENT

Pour ne pas compromettre la protection contre le choc électrique, ne pas couper le circuit de continuité des masses de la fiche.

L'interrupteur avant de cet appareil ne coupe pas la totalité de l'alimentation des circuits internes. En cas d'urgence, l'utilisateur peut

devoir débrancher cet appareil. Ne pas bloquer l'accès au cordon d'alimentation ou (si l'appareil est installé sur un châssis) au disjoncteur alimentant l'appareil.

Si un interrupteur de secours à distance est branché à cet appareil au moyen d'un connecteur Sub D à 25 broches du panneau arrière, il est possible que l'utilisateur n'arrive pas à mettre l'appareil hors tension au moyen de l'interrupteur frontal. Avisez l'utilisateur de l'emplacement du dispositif de sectionnement (cordon ou disjoncteur) de l'appareil.

Power Cord Bracket

Although Hewlett-Packard does not supply a power cord bracket with the HP E1401 High-Power Mainframe, there are two PEM nuts on the power supply (see figure 1-2) to which you can attach your own bracket.

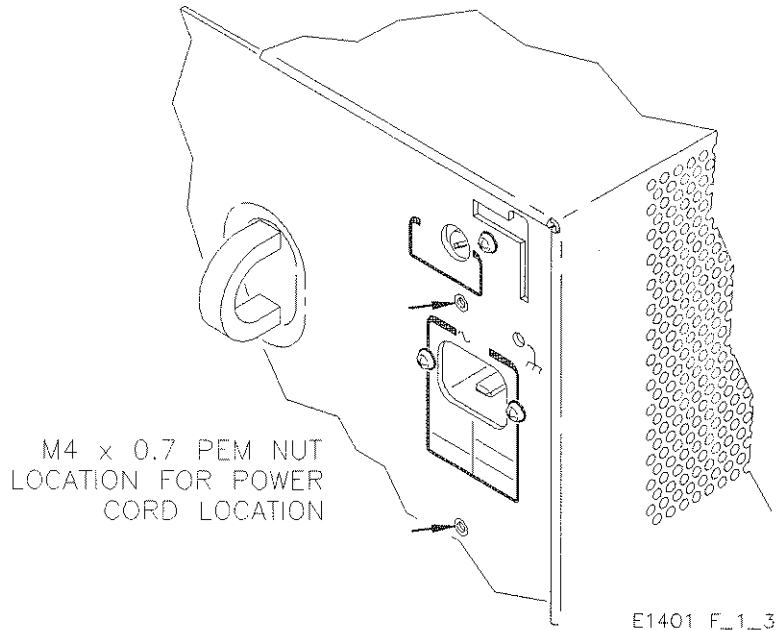

Figure 1-2. PEM Nuts for Power Cord Bracket

Mainframe Hardware Description

About this Chapter

This chapter gives a hardware description of the High-Power Mainframe and contains the following sections:

- Backplane Description 2-1
- Mainframe Cooling System Description 2-2
- Requirements for Modules 2-4
- Installing Modules 2-5
- Plug-in Module Selection and Special Design 2-6
- Using Chassis Shield and Backplane Connector Shields 2-7
- Using Faceplate Panels 2-7
- Rack Mounting the Mainframe 2-7

Backplane Description

The mainframe's 13 slots are on 30.48 mm (1.2 in.) centers and provide the J1 and J2 VXIbus backplane connectors. All pins on J1 and J2 are fully implemented according to the VXIbus Specification (Revision 1.4). Both connectors are DIN 96-pin connectors with pin spacing on 2.54 mm (0.1 in.) centers.

The backplane automatically bypasses empty slots for daisy-chained signals required by the VXIbus and VMEbus specifications. Solid state devices automatically route the bus grant lines BG(0-3)IN* around an empty slot to the corresponding BG(0-3)OUT* lines. These devices also route the IACKIN* line around an empty slot to the IACKOUT* line. Backplane jumpers or DIP switches are not necessary since the solid state devices are automatically activated when a module is installed.

Note

In the discussion of hardware operations that follow, a mnemonic suffixed with an asterisk (e.g., IACKIN*) indicates reverse logic ("0" or low = true; "1" or high = false).

The backplane circuit board assembly uses a multi-layer circuit board with electrical components mounted on both sides. Figures in Appendix B show component locations for both sides of this circuit board.

Most components are mounted to the backplane circuit board in compression sockets for easy troubleshooting and replacement. Some components are soldered into solder cup sockets but no parts are soldered to the backplane itself.

Mainframe Cooling System Description

The mainframe supplies each of the 13 module slots with enough circulation air to cool 60 Watts while maintaining a 10°C rise across a typically-dense module. Up to 75 Watts per slot may be dissipated if a 15°C rise is acceptable across a typically-dense module.

The mainframe rear panel assembly contains three circulation fans. The speed of these fans is controlled by the ambient temperature of the air drawn into the mainframe. Because of the mainframe's pressurized plenum design, the airflow to each slot is independent of loading on adjacent slots.

Filtered air enters the rear of the mainframe through the fans. The incoming air is forced downward to holes below each slot. The air is channeled upward into each slot and passes over each module's components. The air passes over the top of the modules and exits from the sides and top of the mainframe chassis.

Air outlet holes are provided on top of the mainframe for high-power applications. If any module exceeds 40 Watts, you should provide at least 20 mm (0.8 in.) of clearance above the mainframe. If no module exceeds 40 Watts, the outlet holes on the sides of the mainframe are sufficient.

A fourth fan provides cooling air for the power supply. Filtered air enters one side of the mainframe and exits from the opposite side after passing through the power supply.

Caution

When installing the mainframe in your system environment, use care to see that the air inlets and outlets are not obstructed. This will prevent damage to the mainframe and installed modules due to overheating.

Clean all air filters regularly.

Mainframe Cooling Capacity

Before installing modules in the mainframe, you must verify that the mainframe has enough cooling capacity. A quick check here is to compare the worst case power dissipation of any module against the mainframe's abbreviated cooling specification. For the HP E1401 Mainframe, this cooling specification is 60 Watts per slot.

A more exact method to verify compatibility is to use the detailed VXIbus cooling specifications of the mainframe and modules. The detailed specification is given in terms of airflow rate versus back pressure (change in pressure across the module).

Figure 2-1 shows the graph of airflow volume (liters/second) versus change in pressure across the module (mm H₂O) for the mainframe. The values shown are the minimum airflow values available per slot. The slot with the lowest airflow was tested with all other slots empty. The airflow and change in pressure required is specified for each VXIbus module and must be below the appropriate ambient curve for the mainframe.

For most applications, you should compare the module's detailed cooling specification with the curve for the mainframe (ambient temperature 40°C). Cooling is most critical at the highest ambient temperatures.

Note

It is your responsibility to ensure adequate cooling is supplied to all modules installed in the mainframe. Section B.7.2.4 of the VXIbus Specification (Revision 1.4) discusses module cooling requirements. Section B.7.3.5 discusses mainframe cooling requirements.

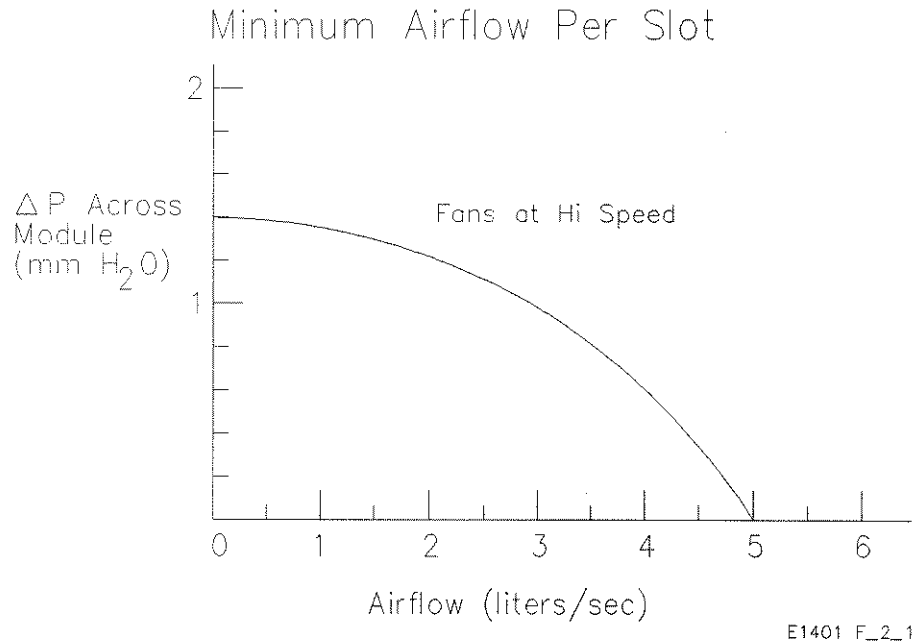

Figure 2-1. Minimum Airflow Available Per Slot

Variable-Speed Fan Control

Normally, the speed of the four internal circulation fans is controlled by the ambient temperature of the air drawn into the mainframe. There is one fan used to cool the power supply module and three fans to cool any modules inserted into the HP E1401 High-Power Mainframe. In a cool environment, the fans operate at a quiet but effective speed to reduce acoustic noise. When maximum cooling is needed, the fans automatically speed up to provide the required cooling. You can override the temperature-controlled speed of the fans by changing the position of the Fan Speed Control Switch on the rear of the mainframe to "High." This forces all four fans to remain at full speed all of the time. The two fan modes are:

- Variable Speed Mode: Quiet operation (~75% airflow) at <math><30^{\circ}\text{C}</math>. High speed operation at $>40^{\circ}\text{C}$ ambient.
- High Speed mode: Full airflow at all times

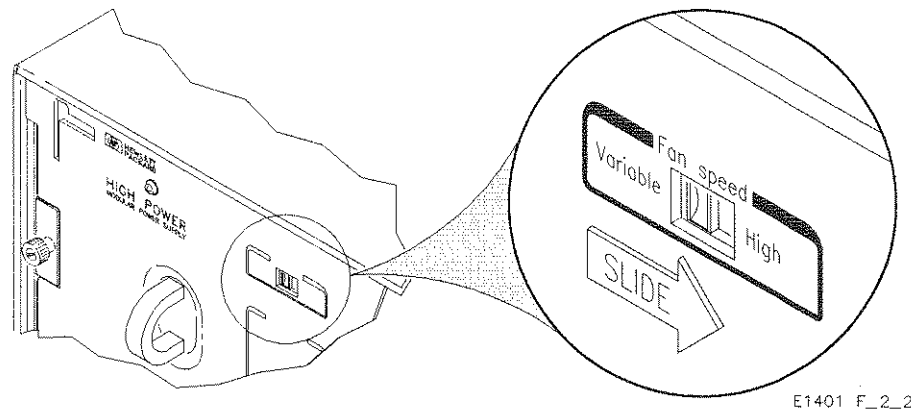

Figure 2-2. Forcing the Fan to High Speed

Requirements for Modules

Modules should be carefully inspected for compliance to the mechanical and electrical standards set forth in the VXIbus Specification (Revision 1.4). This manual does not consider any regulatory requirements for specific module applications. It is your responsibility to meet requirements for FCC/VDE/EN emissions, safety, or any other regulatory requirements. Areas for consideration include:

- Mechanical dimensions
- Power requirements
- Cooling requirements
- Electrostatic discharge (ESD) susceptibility
- Conducted emissions/susceptibility
- Radiated emissions/susceptibility (shielding)
- Signal levels
- Timing
- Backplane protocol

It is your responsibility to ensure that power requirements of modules installed in the mainframe are in conformance with the Power Management Requirements. Power requirements are outlined in Section B.8.5 of the VXIbus Specification (Revision 1.4).

All power supply voltages used on modules installed in the mainframe should be fused on the module. This protects the modules and the mainframe and will satisfy most safety regulatory requirements. For example, the mainframe's +5 VDC supply is capable of supplying 60 Amps. An electrical short on an unfused module may cause backplane damage through the +5 VDC pins supplying power to the shorted module. Damage to the mainframe caused by a shorted module that is not properly fused may void all or part of the mainframe warranty.

Installing Modules

WARNING

SHOCK HAZARD. Only service-trained personnel who are aware of the hazards involved should install, remove, or configure any plug-in modules. Before you touch any installed module, disconnect AC power from the mainframe.

To avoid electrical shock and maintain fire containment capability, always use the faceplate panels that came with the mainframe to cover unused slots. Refer to Appendix B in this manual for the faceplate panel part numbers if you wish to order additional panels.

ADVERTISSEMENT

RISQUE DE CHOC ÉLECTRIQUE. Seul un technicien qualifié conscient des risques en jeu devrait installer, enlever ou régler un module enfichable. Avant de toucher à un module installé, coupez l'alimentation c.a. du processeur central.

Pour éviter les chocs électriques et maintenir la capacité de protection contre la propagation des flammes, assurez-vous de couvrir les fentes libres du processeur central au moyen des plaques fournies. Si vous désirez commander des plaques supplémentaires, consultez l'appendice B de ce manuel pour connaître les numéros de pièces.

Installing C-Size Modules

You can install C-Size modules directly into the mainframe by first placing the module's card edges into the front module guides (top and bottom). Then slide the module to the rear of the mainframe until the module connectors mate solidly with the backplane connectors. Secure the module's front panel to the mainframe chassis using the module's mounting screws.

Installing A-Size and B-Size Modules

The easiest way to install B-Size modules is with the optional HP E1403A Active Adapter. This product allows a B-Size module to be installed just like a C-Size module. The HP E1403A supports slave devices with the P1 connector only.

B-size modules may be installed by removing the module's front panel. With the front panel removed, insert the card edges into the module guides and slide the module into the mainframe until the backplane connectors are solidly mated. In this

configuration the module is supported by the module guides and backplane connectors, without the added security of the front panel screws to secure it to the mainframe.



Plug-in Module Selection and Special Design

The E1401 High-Power Mainframe is CSA (Canadian Standards Association) certified. Recommended plug-in modules should be CSA certified or be designed to meet CSA, UL (Underwriters Laboratories), or IEC (International Electrotechnical Commission) safety standards as is appropriate for the intended function of the module and local codes. Contact your safety engineer for assistance.

For custom designed plug-in modules, compliance to the appropriate CSA, UL, or IEC safety standards is recommended.

- For protection against possible fire damage, module circuits connected to mainframe power supply voltages capable of continuously supplying more than 8A to a low resistance fault should be investigated as an ignition source as required by the identified safety standards.

NOTE

A short circuit or a very near short circuit condition will cause the mainframe power supply overcurrent protection to shut the power supply down until the condition is removed.

-
- For protection against possible electrical shock hazard, provide adequate isolation for normal operation and fault conditions. Be sure to isolate hazardous voltage from mainframe backplane voltages. Hazardous voltage may be generated internal to the module or be input to the module from an external source.
 - Refer to the identified safety standards above or contact your safety engineer for guidance on fire and electrical shock protection and other conditions for which product and operator protection may be required.



Using Chassis Shield and Backplane Connector Shields

The HP E1409B Chassis Shield is the Hewlett-Packard implementation of Section B.7.3.4 of the VXIbus Specification (Revision 1.4) that allows grounded shielding between mainframe slots. Typical applications for the chassis shield include isolating modules that generate electromagnetic interference (EMI) at excessive levels, or protecting modules making sensitive measurements from noise sources.

The chassis shield assembly contains a plated steel shield with four conductive chassis shield guides and mounting hardware. Two adhesive-backed thermoplastic insulators are also included and can be attached to the chassis shield if desired. Since the chassis shield fits between slots in the mainframe, you don't lose the use of a slot by installing the shield.

The Backplane Connector Shield Kit (HP part number E1400-80920) is the Hewlett-Packard implementation of figure B.36 of the VXIbus Specification (Rev 1.4) that allows a contact surrounding the backplane connector. These contacts mate with spring fingers on some VXIbus modules. Typical applications include improving the ground return path and reducing EMI. The kit includes 26 contacts and mounting hardware.

Using Faceplate Panels

The mainframe is shipped from the factory with faceplate panels installed to cover the module slots. Three 1-slot panels, one 3-slot panel, and one 7-slot panel are installed to cover the 13 slots.

To avoid electrical shock, always use the faceplate panels to cover unused slots. Refer to Appendix B in this manual for the faceplate panel part numbers if you wish to order additional panels.

Rack Mounting the Mainframe

The mainframe can be used as a benchtop instrument or you can rack mount it in a standard 19-inch wide rack mounting cabinet. There are many different rack mounting accessories available. From mass interconnect products to a cable tray, everything you need to integrate your VXI mainframe is available from Hewlett-Packard.

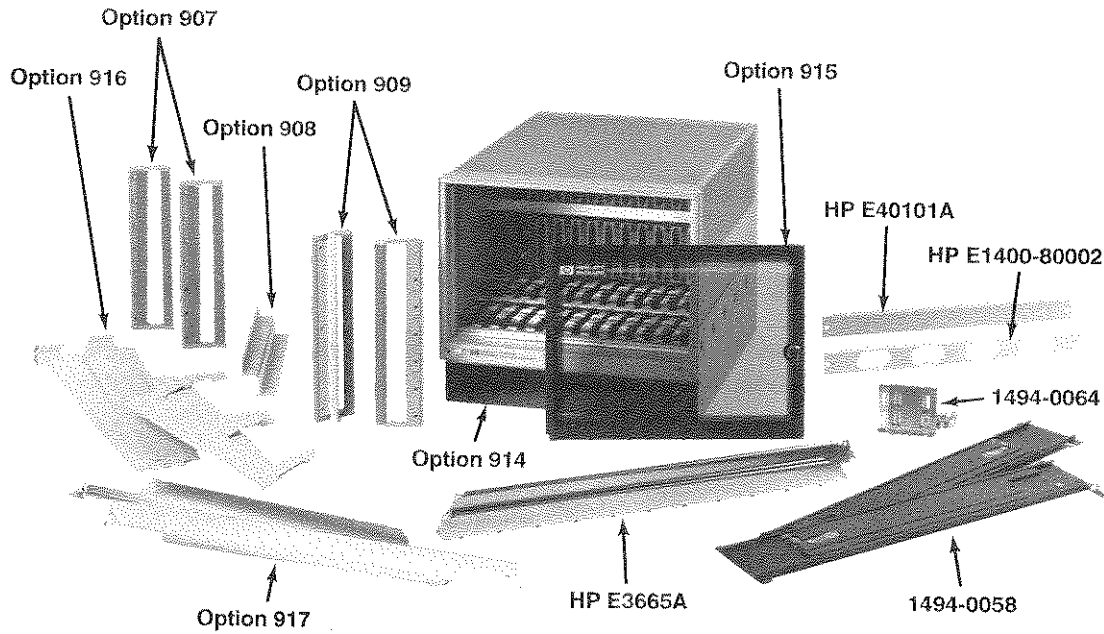

For the following configurations...	Recommended Configurations																						
	A	B	C	D	E	F	G	H	I	J	K	L	M	N	O	P	Q	R	S	T	U	V	W
Bench top																		
Rack Mount				
Mass Interconnect - Direct Access ICA					.	.																	
- Hinged ICA							.	.															
Smoked Acrylic Door							
Recess Mount				
Rack Slides				
Cable Tray - 44.5mm (1.74 in)				
- 88.9mm (3.5 in)				
Handles				
You need to order...																							
Opt 907 (5062-3993) Handle Kit	.	.																					
Opt 908 (5062-3981) Flange Kit									
Opt 909 (5062-3987) Handle & Flange Kit									
Opt 914 (E1400-80004) Cable Tray Kit
Opt 915 (E1400-80915) Smoked Acrylic Door Kit									
Opt 916 (E1401-80916) Recess Mount Kit									
HP E3665A Rail Kit preferred for HP E366XA Racks									
Opt 917 (E1401-80917) VXI Support Rail Kit for any HP Racks					
Rail Kit from non-HP rack vendor (not supplied by HP)					
1494-0058 Heavy Duty Rack Slide Kit								
1494-0064 Slide brackets for non-HP Racks					*	*	*							*	*			*	*				
HP E3720A Direct Access ICA					.	.																	
HP E3722A Hinged ICA						.	.																
E1400-80002 Cable Access panel - 44.5mm (1.75 in)									
HP 40101A Filler Panel - 44.5mm (1.75 in)									

↑ = either or * = if you need them

Power Supplies and Auxiliary Connector

About this Chapter

This chapter describes the mainframe power supplies and contains the following sections:

- Maximum Power Ratings 3-1
- Backplane Voltage Pinout 3-2
- Using Power Supply Outputs 3-2
- Rear Pane Auxiliary Connector 3-3

Maximum Power Ratings

All seven mainframe power supply outputs are over-voltage and over-current protected at their maximum rated outputs as shown in Table 3-1 and Table 3-2.

Table 3-1. Power Supply Input Power*

Voltage	Maximum Current	Fuse
100V	15A	15AF
120V	12A	15AF
220-240V	8A	15AF

Nominal Frequency: 50/60/400 Hz
 Low Range: 45 to 66 Hz
 High Range: 360 to 440 Hz (120 VAC only)

Table 3-2. Power Supply Outputs

DC Output Voltage	Peak DC Output Current (IMP*)	P-P Dynamic Current (IMD**)	DC Current Limit (supply shuts down)
+5V	60A	9.0A	70-80A
+12V	12A	2.5A	14-18A
-12V	12A	2.5A	14-18A
+24V	12A	5.0A	15-19A
-24V	10A	5.0A	12-16A
-5.2V	60A	8.5A	70-80A
-2V	30A	4.5A	35-41A
+5V STDBY	0A	0.0A	

*IMP = Rated mainframe peak DC output current as defined by the VXibus Specification.

**IMD = Rated mainframe peak-to-peak dynamic current as defined in the VXibus Specification by a current versus frequency curve.

Backplane Voltage Pinouts

Table 3-3 shows the backplane J1 and J2 connector pin numbers from which the power supply voltages and ground returns are available.

Although traces are provided in each slot for +5V STDBY (connector J1, pin B31), this voltage is not provided by the mainframe. If this voltage is required, you must provide it through the 25-pin Sub D connector located on the rear of the mainframe.

Table 3-3. Backplane Connector Power Pinouts

Voltage	Connector and Pin Numbers
+5 VDC	(J1) A32, B32, C32 (J2) A25, B1, B13, B32
-5.2 VDC	(J2) A7, A13, A19, C4, C19
+5V STDBY	(J1) B31
+24 VDC	(J2) C31
-24 VDC	(J2) C32
+12 VDC	(J1) C31
-12 VDC	(J1) A31
-2 VDC	(J2) A2, C13
GROUND	(J1) A9, A11, A15, A17, A19, B20, B23, C9
GROUND	(J2) A4, A10, A16, A22, A28, A31, B2, B12, B22
GROUND	(J2) B31, C3, C7, C10, C16, C22, C25, C28, C30

Using Power Supply Outputs

The following is a list of recommended usages for the voltages available from backplane connectors J1 and J2.

+5 VDC	Main power source for all systems. Supplies power to logic devices.
-5.2 VDC	Power for ECL devices.
+5V STDBY	Power to sustain memory, clocks, etc. when +5 VDC is lost. The HP E1401 Mainframe does not provide this voltage. You must supply this voltage through the 25-pin Sub D connector on the rear of the mainframe if it is required for your application.
+24 VDC	General purpose power for high level output drivers. Used to derive voltages for precision analog devices (e.g., +15 VDC).
-24 VDC	General purpose power for high level output drivers. Used to derive voltages for precision analog devices (e.g., -15 VDC).
+12VDC	General purpose power for switching power converters, analog devices, and disc drives.
-12VDC	General purpose power for switching power converters, analog devices, and disk drives.
-2 VDC	Power for ECL termination loads.

Rear Panel Auxiliary Connector

An additional 25-pin Sub-D connector is provided on the rear panel of the mainframe to allow monitoring of power supply voltages as well as other functions. The pinouts for this connector are shown in table 3-4.

Table 3-4. Power Supply Auxiliary Connector Pinout

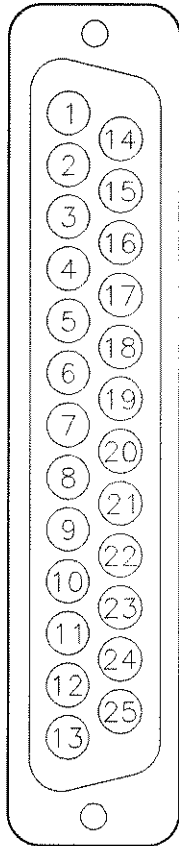

E1401 TABLE3_4

Pin #	Function	Description
1	+5VM	+5V for voltage monitoring (2.4mA max).
2	-12VM	-12V for voltage monitoring (2.4mA max).
3	-24VM	-24V for voltage monitoring (2.4mA max).
4	-2VM	-2V for voltage monitoring (2.4mA max).
5	REM STDBY	Remote power switch.
6	+5V	+5V output for charging batteries, running external TTL circuitry, etc. 1A maximum.
7	+12V	+12V output for charging batteries, running external TTL circuits, relays, etc. 1A maximum.
8	+5V STDBY	Input for +5V standby current (e.g., from external battery). Max 1A combined total (pins 8 & 21).
9	GND	Chassis ground
10	SYSRESET*	Backplane SYSRESET signal (input or output). If you use this pin, be careful not to violate backplane electrical specifications (i.e., keep extender cable as short as possible).
11	EXHAUST_TEMP	An analog output signal proportional to the power supply exhaust temperature.
12	N/C	Not used
13	N/C	Not used
14	+12VM	+12V for voltage monitoring (2.4mA max).
15	+24VM	+24V for voltage monitoring (2.4mA max).
16	+5.2VM	+5.2V for voltage monitoring (2.4mA max).
17	GND	Chassis ground
18	REM SW	Remote power switch return.
19	GND	Chassis ground
20	GND	Chassis ground
21	+5V STDBY	Input for +5V standby current (e.g., from external battery). Max 1A combined total (pins 8 & 21).
22	GND	Chassis ground
23	AC FAIL*	Backplane AC FAIL signal (input or output). If you use this pin, be careful not to violate backplane electrical specifications (i.e., keep extender cable as short as possible).
24	GND	Chassis ground
25	N/C	Not used

Remote Standby Switch

The remote standby switch connection is provided to let you turn the unit ON or put it in STANDBY mode remotely. These two connections are wired in parallel with the front panel ON/STANDBY switch. This means that the front panel switch must be in the STANDBY position for the remote switch to function correctly.

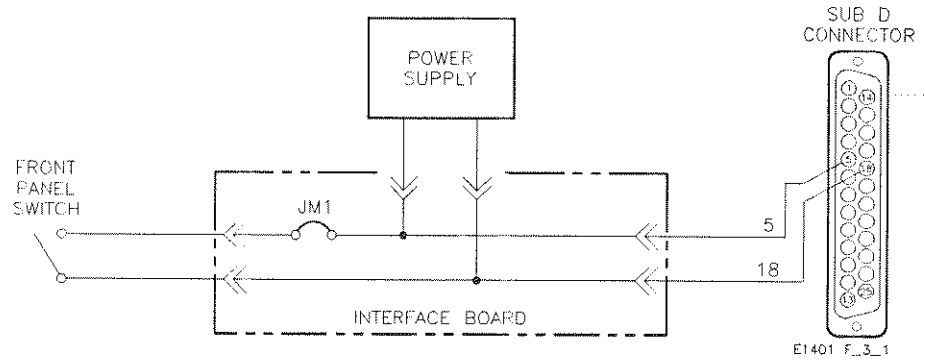

Figure 3-1. Remote Standby Switch Wiring

If you wish to completely disable the front panel switch, you can cut the jumper JM1 on the power supply interface board. Figure 3-2 shows the location of this jumper. Once this is cut, the only way to control power (besides pulling the plug) is through a switch connected to the 25-pin Sub-D connector on the rear of the mainframe. To access the interface board, remove the power supply according to the instructions in Appendix B.

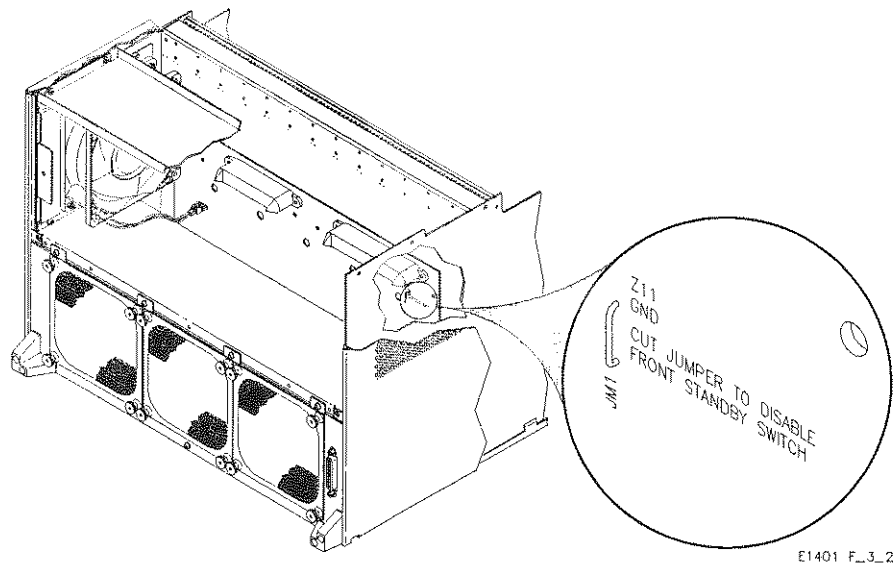

Figure 3-2. Location of Jumper JM1

+5V The +5V output lets you power external TTL circuitry if required. The maximum current allowed from this circuit is 1A.

3-4. Power Supplies and Auxiliary Connector

+12V The +12V output lets you power a battery charging circuit to provide a source for the +5VSTDBY input. There are provisions on the rear of the power supply to let you mount a battery bracket if required. You must supply your own battery bracket. The maximum current allowed from this circuit is 1A.

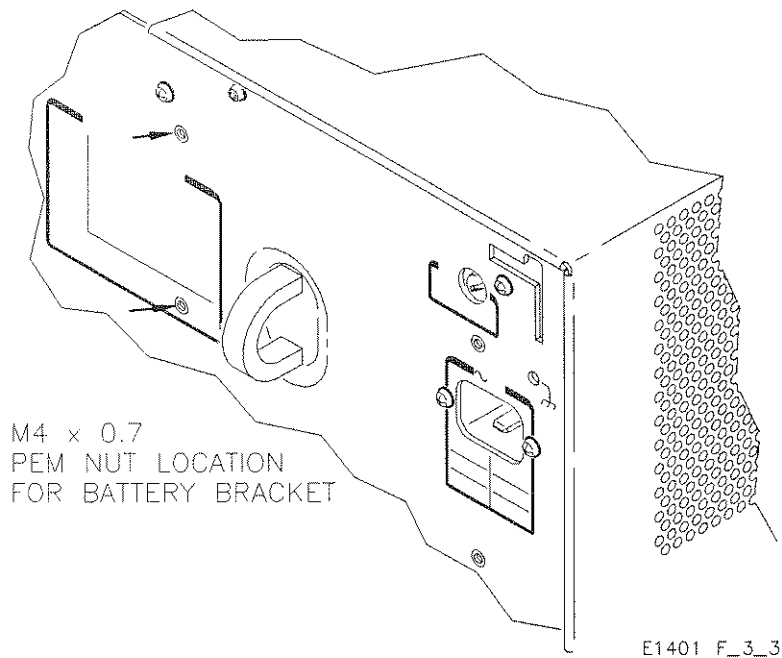

Figure 3-3. PEM Nut Locations for Battery Bracket

+5VSTDBY Provides an input to the backplane for a +5V standby power source. This may be from a battery mounted to the unit or from a separate battery or power supply. The maximum input current allowed is 1A. This means that all of the standby circuitry in all of the modules mounted in the mainframe can draw a total of 1A when active.

SYSRESET* Provides an extension of the backplane SYSRESET* signal. It can be used to monitor for SYSRESET* or to send SYSRESET* to the backplane. Shorting this pin to ground will input a SYSRESET* signal to the system. If you use any extension cable out of the 25-pin Sub D connector on the rear of the mainframe, make sure that you do not violate VXI backplane electrical specifications (i.e., keep the cable short or buffer it).

ACFAIL* Lets you monitor the ACFAIL* signal from the backplane. Since this pin is connected directly to the backplane, you should be careful not to violate VXI backplane electrical specifications (i.e., keep the cable short or buffer it).

EXHAUST_TEMP Provides an analog output that is proportional to the power supply exhaust temperature. Using this circuit, you can monitor the actual temperature of the power supply exhaust temperature to receive a warning signal that the mainframe is running under abnormal conditions. This output provides 0VDC at 0°C, with a rise of 10mV per degree centigrade when referenced to chassis ground.



Specifications

The E1401 High-Power Mainframe is 100% compatible with VXIbus specification Revision 1.4.

Mainframe Size:

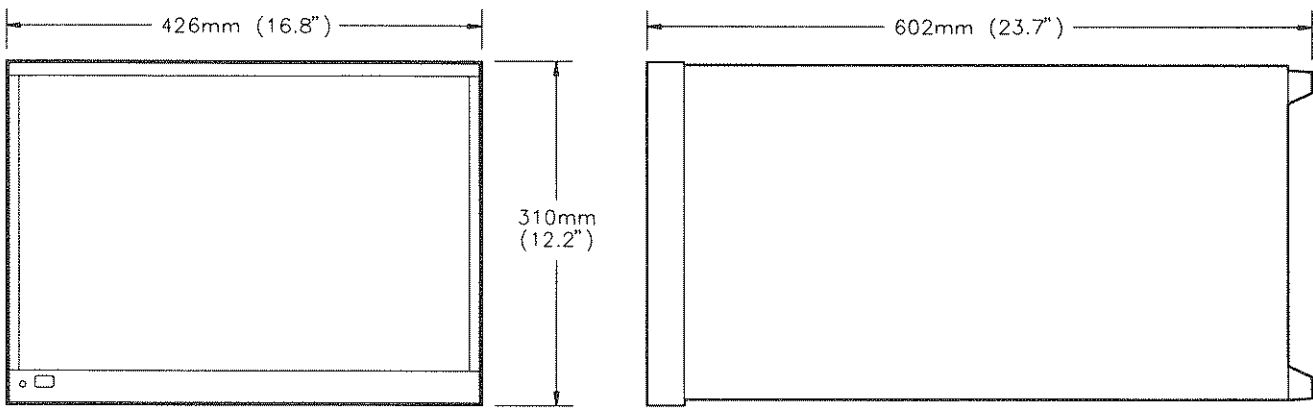

E1401 F_A_1

Mainframe Weight:

18.6 Kg (41 lbs) with no modules installed

Module Size:

Thirteen (13) C-Size slots. The mainframe also accepts A- or B-Size modules using the optional HP E1403A Module Carrier.

Input Power:

Voltage	Maximum Current	Fuse
100V	15A	15AF
120V	12A	15AF
220-240V	8A	15AF

Automatic Voltage Ranging (no switch): 100-240 VAC

Automatic Frequency ranging: 50/60/400 Hz

Low Range: 48 to 66 Hz

High Range: 360 to 440 Hz (120 VAC only)

Power Factor Correction

Power Switch: On/Standby with lighted indicator in front.

Rear panel connection allows remote operation.

Inrush Current: 40A max

Designed to meet EN-60555-2

Socket for detachable line cord: IEC 320 "Hot."

Chassis ground tap on rear panel: M4 x 0.7 threaded insert.

Power Supply Outputs:

DC Output Voltage	Peak DC Output Current (IMP*)	P-P Dynamic Current (IMD**)	CD Current Limit (supply shuts down)
+5V	60A	9.0A	65-80A
+12V	12A	2.5A	14-18A
-12V	12A	2.5A	14-18A
+24V	12A	5.0A	14-19A
-24V	10A	5.0A	12-17A
-5.2V	60A	8.5A	65-80A
-2V	30A	4.5A	35-41A
+5V STDBY	0A	0.0A	

*IMP = Rated mainframe peak DC output current as defined by the VXIbus Specification.

**IMD = Rated mainframe peak-to-peak dynamic current as defined in the VXIbus Specification by a current versus frequency curve.

VXI Ripple/Noise*

DC Output Voltage	Allowed Variation	Max DC Load Ripple/Noise	Max Induced Ripple/Noise
+5V	+ .25/- .125	50 mV	50 mV
+12V	+ .06/- .36	50 mV	50 mV
-12V	- .60/ + .36	50 mV	50 mV
+24V	+ 1.2/- .72	150 mV	150 mV
-24V	- 1.2/+ .72	150 mV	150 mV
-5.2V	- .26/+ .156	50 mV	50 mV
-2V	- .10/+ .10	50 mV	50 mV

*Per VXI specification rev. 1.4

Maximum Power Output**

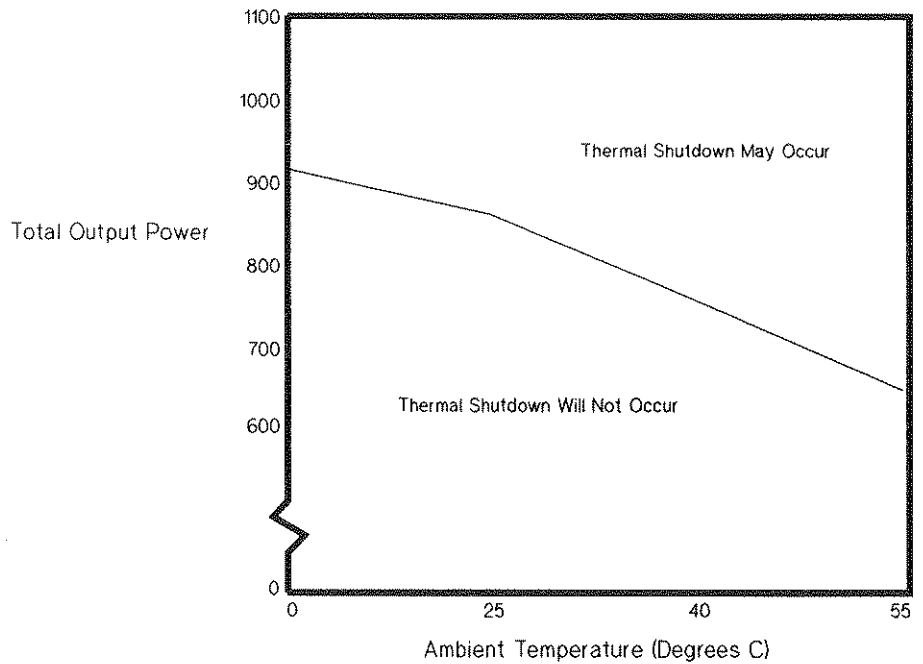

** Uncertainty in shutdown is due to variable loadings. Heavy loading on +5V, -2V, and -5.2V will cause shutdown at the lower edge of the band. Heavy loading of the +12V, -12V, +24V, or -24V will cause shutdown at the higher edge of the band. Low line voltage (90VAC) will cause shutdown at the lower edge of the band.

Humidity:

Exceeds MIL-T-28800D test limit 3.7.2
40°C and 95% RH

Temperature Range:

Exceeds MIL-T-28800D test limits 3.7.2
Non-operating: -40°C to +75°C
Operating: 0°C to 55°C

Shock and Vibration:

Meets the following MIL-T-28800D test limits:
Vibration test limits 3.7.4.1 and 4.5.5.3.1
Shock test limits 3.7.5.1 and 4.5.5.4.1
Bench handling test limits 3.7.5.3 and 4.5.5.4.3

Cooling Provided:

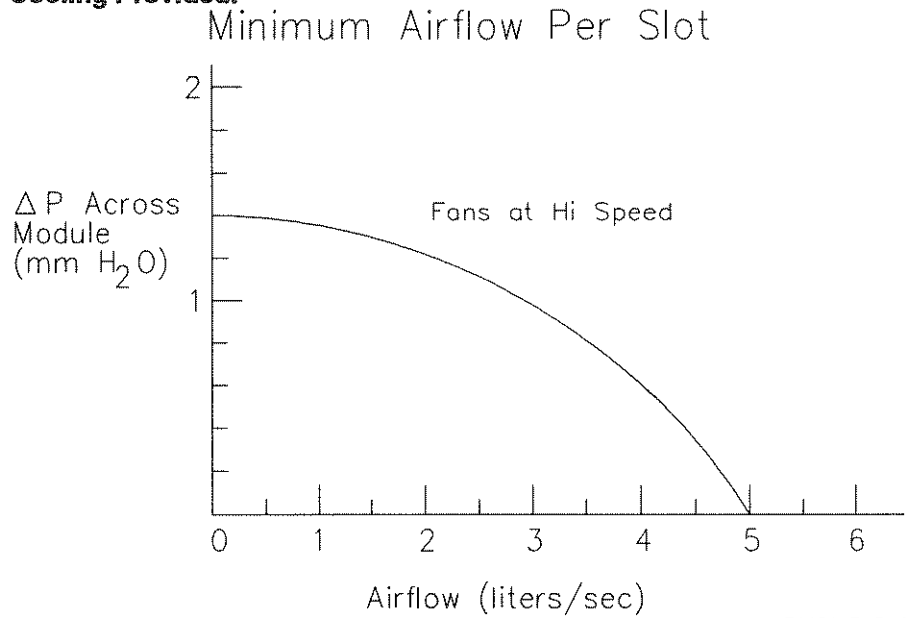

Fan set to "Variable": Quiet operation (approx. 75% airflow) at <30°C ambient and high speed operation at >40°C ambient.

Fan set to "High": Full airflow at all time.

For modules with typical density:

10°C rise at 60W per slot

15°C rise at 75W per slot

Acoustical Noise:

Low speed fan: 48 dBA sound pressure at bystander position.

Lpa = 48 dB fiktiver Arbeitsplatz, normalier Betrieb, nach DIN 45635 T.1

High speed fan: 56 dBA sound pressure at bystander position.

Lpa = 56dB fiktiver Arbeitsplatz, normalier Betrieb, nach DIN 45635 T.1

Classification:

Classified under MIL-T-28800 as Type III, Class 5, Style E, Color R

EMC Testing:

CISPR 11:1990/EN 55011 (1991): Group1 Class A

IEC 801-2:1991/EN 50082-1 (1992): 4kVCD, 8kVAD

IEC 801-3:1984/EN 50082-1 (1992): 3 V/m

IEC 801-4:1988/EN 50082-1 (1992): 1kV

Within the requirements of MIL-STD-461 methods CE01, CE03 (relaxed 30 dB below 2 MHz, relaxed 10 dB between 2 and 15 MHz), CS01, CS02, CS06, RE01 (relaxed 10 dB), RE02, RS02, RS03.

Module Weight:

Maximum 3.5 Kg (7.7 lbs) per slot to comply with vibration and shock specifications. Heavier modules may be installed if vibration and shock environment is less severe.

Safety:

IEC 348, UL 1244, and CSA C22.2 #231

Typical Line Current vs. Output Power @ 120 VAC Line

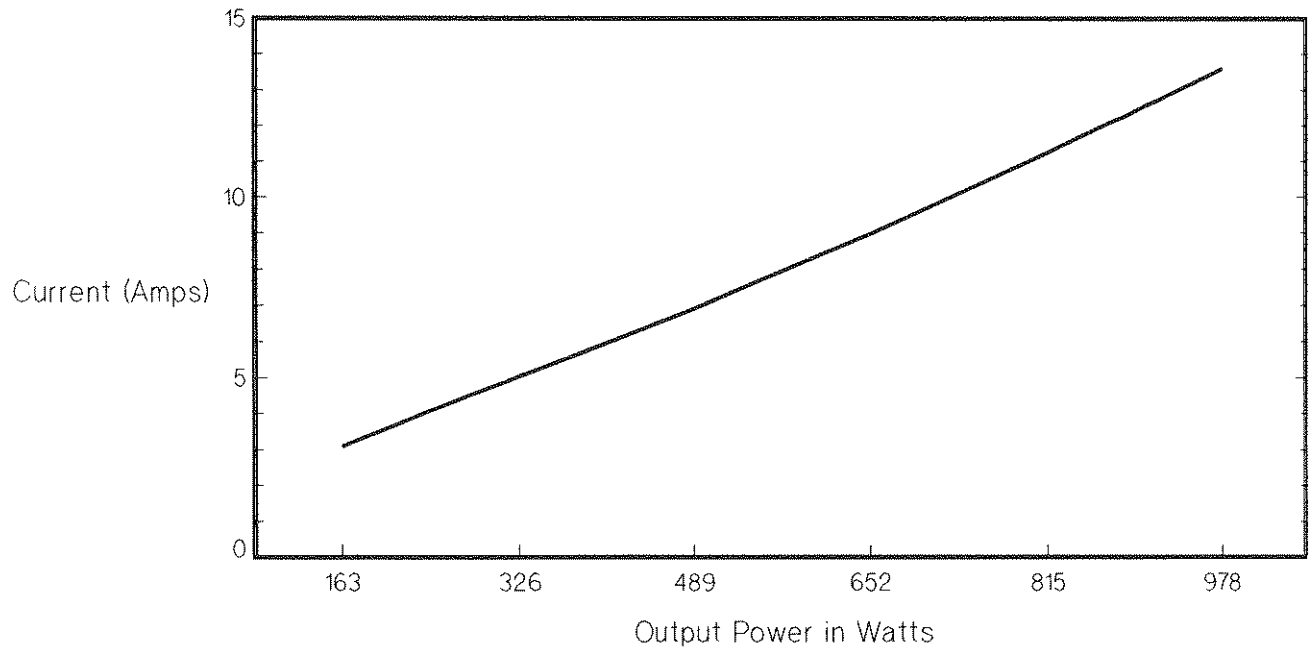

- The load used was proportional, that is, each supply provided power in proportion to its fully loaded value.
- Tests were performed at 25° C.

Replaceable Parts & Modules

About this Appendix

There are a number of easily replaceable modules in the HP E1401 High-Power Mainframe. These modules and other replaceable parts in the mainframe are listed in tables B-1 through B-3. This appendix includes the following sections.

- Recommended Service Procedures B-1
- Replaceable Parts Lists B-1
- Removing the Power Supply Fan Filter B-12
- Removing the Mainframe Fan Filters B-12
- Removing the Power Supply B-13
- Power Supply Fan B-14
- Removing the Mainframe Fan Assembly B-15
- Replacing a Plastic Module Guide B-16

Recommended Service Procedures

You should repair the E1401-66502 Power Interface Printed Circuit Assembly (PCA), E1401-66501 Backplane PCA, and mechanical parts to the component level when possible. The Power Supply should be replaced as a module. The exchange module part number (a rebuilt 0950-2283) is E1401-69201.

WARNING

There are no user serviceable parts inside. Refer repair and servicing to trained service personnel.

AVERTISSEMENT

Ne contient pas d'élément que l'utilisateur puisse réparer. Confier les réparations et la maintenance à un technicien qualifié.

CAUTION

Because of possible damage to the Backplane PCA, which uses a multi-layer circuit board, we recommend that you do not try to make any solder connections to the backplane. Most components are mounted to the circuit board in compression sockets for easy replacement. Some components are soldered into solder cup sockets but no parts are soldered to the backplane itself. The DIN connectors on the Backplane PCA are compression fit directly to the circuit board and are not replaceable. You must replace the entire backplane if a DIN connector fails.

Hewlett-Packard recommends that the Rear Panel Assembly (E1401-60201) containing the three cooling fans be replaced as an assembly. However, the individual parts can be replaced if required.

Replaceable Parts Lists

Table B-1 lists the HP E1401 High-Power Mainframe hardware. To order a part, contact the vendor listed under Mfg. Code (see Table B-4 for a list of manufacturer's) and quote the mfr. part number, desired quantity, and description.

Table B-1. HP E1401 High-Power Mainframe Parts List

Reference Designator	HP Part Number	Total Qty.	Description	Mfr. Code	Mfr. Part Number
A1	E1401-66501	1	PC Backplane Assembly	28480	E1401-66501
A2	0950-2283	1	Power-Supply; Pwr-650W; 8 Outputs	28480	0950-2283
A3	E1401-66502	1	PC Assembly-Power Interface Board	28480	E1401-66502
A4	E1401-60201	1	Rear Panel Assembly	28480	E1401-60201
B1 - B3	3160-0377	3	Fan Tubeaxial 122-CFM 9.5-14VDC	28480	3160-0377
CBL1	E1401-61601	1	Cable Assy 25 Cond Ribbon	28480	E1401-61601
HDW1-HDW12	0515-0099	12	Nut-M3 X 0.5 7.5mm-thk 12-mm OD	28480	0515-0099
MP2 - MP4	09101-04601	3	Screen-Filtr	28480	09101-04601
MP6 - MP8	3150-0218	3	Filter-Air 32 Std Mesh Metal Screen	28480	3150-0218
NL1	E1401-00201	1	Rear Panel	28480	E1401-00201
A4W3 - W5	E1400-61633	3	Cable-Fan	28480	E1400-61633
BZL1	E1401-04303	1	Front Bezel-Bottom	28480	E1401-04303
BZL2	E1400-44302	1	Bezel-Top	28480	E1400-44302
BZL3	E1401-04301	1	Front Bezel-Left	28480	E1401-04301
BZL4	E1401-04302	1	Front Bezel-Right	28480	E1401-04302
CBL2	E1401-61602	1	Cable - Power Interface to Rear Panel	28480	E1401-61602
CR1	1990-1027	1	Led-Lamp	28480	HLMP-1640
CVR1	E1401-04103	1	Cover-Top	28480	E1401-04103
FI	2110-0054	1	Fuse (inch) 15A 250V NTD FE UL	75915	314 015
MP8	3160-0377	1	Fan-Tubeaxial 122-CFM 9.5-14VDC	28480	3160-0377
MP10	E1401-01204	1	Bracket-Power Supply	28480	E1401-01204
MP12	E1401-04601	1	Air Plenum	28480	E1401-04601
MP13	E1401-01205	1	Bracket-Power Supply Bottom	28480	E1401-01205
MP94	1400-1502	1	Clip-LED-Mounting Polypropylene	28480	1400-1502
MP95 - MP97	1494-0073	6	Slide-Chassis Rear Rail	28480	1494-0073
MP100 - MP102	1494-0073		Slide-Chassis Rear Rail	28480	1494-0073
MP106 - MP129	1494-0074	26	Slide-Chassis Card Guide	28480	1494-0074
MP130	E1401-01206	1	Fan Carrier	28480	E1401-01206
MP131	E1401-81204	1	Filter Carrier	28480	E1401-81204
MP132 - MP134	E1401-41202	13	Card Guide Bottom	28480	E1401-41202
MP135 - MP136	5001-0543	2	Trim-Side Frnt Fr	28480	5001-0543
MP137	5021-8411	1	Frame-Front	28480	5021-8411
MP138 - MP141	5041-8801	4	Foot	28480	5041-8801
MP142	5041-8802	1	Trim Strip Top	28480	5041-8802
MP143 - MP146	5041-8821	4	Stand-Off Rear Panel	28480	5041-8821
MP147 - MP148	1494-0074		Slide-Chassis Card Guide	28480	1494-0074
MP149 - MP150	E1401-81201	2	Mounting Rail-Front	28480	E1401-81201
MP170 - MP179	E1401-41202		Card Guide Bottom	28480	E1401-41202
PNL2-PNL4	E1400-60202	3	Filler Panel - 1 Slot	28480	E1400-60202
PNL5	E1400-00203	1	Filler Panel - 3 Slot	28480	E1400-00203
PNL6	E1400-00204	1	Filler Panel - 7 Slot	28480	E1400-00204
W1	E1400-61632	1	Cable-Power Switch and LED	28480	E1400-61632
W2	E1401-61603	1	Cable-Power Supply Control	28480	E1401-61603
X1	2110-0565	1	Fuseholder Cap 15A Max for UL	28480	2110-0565

B-2 Replaceable Parts

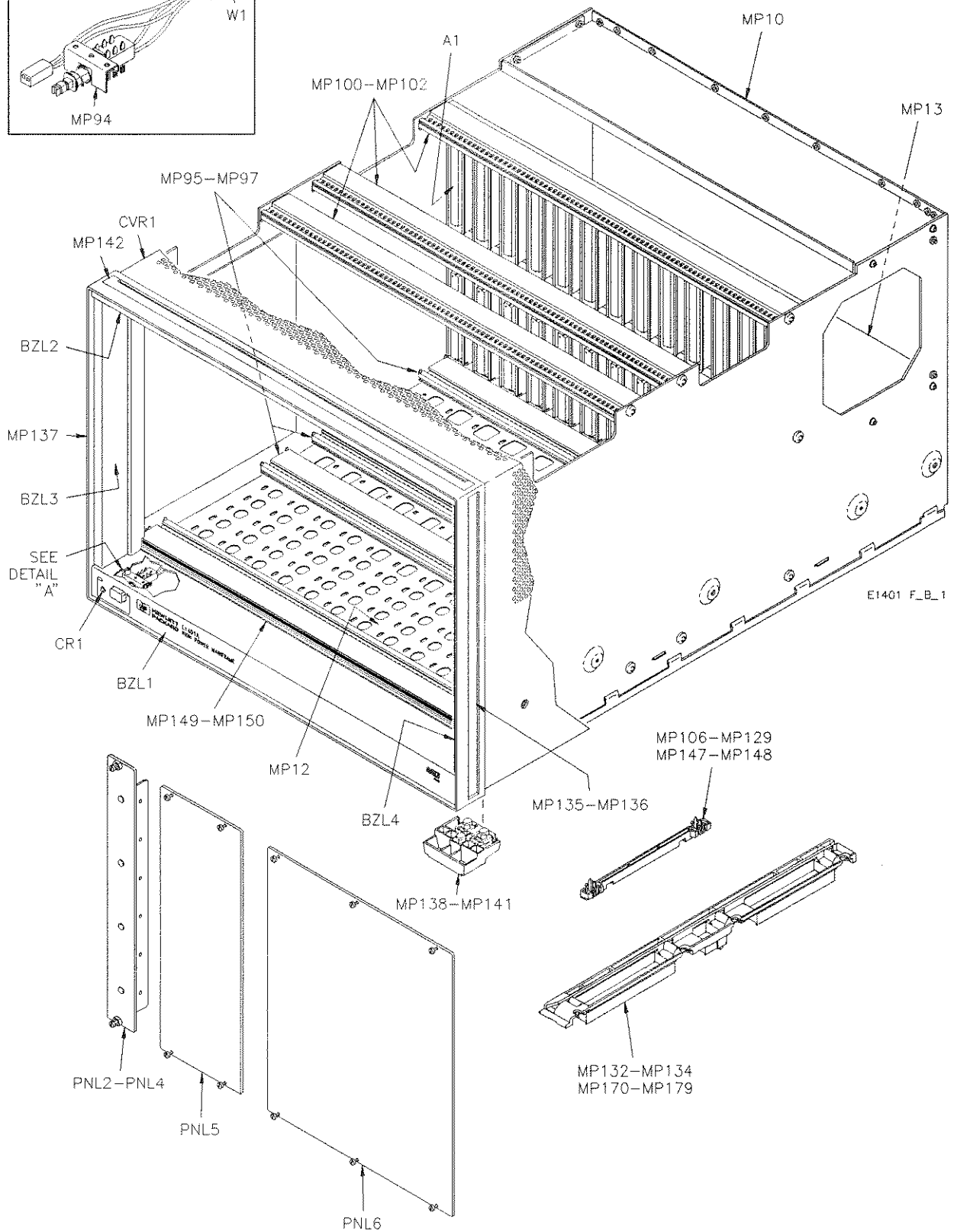
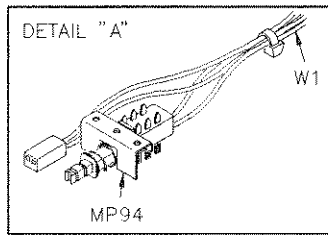
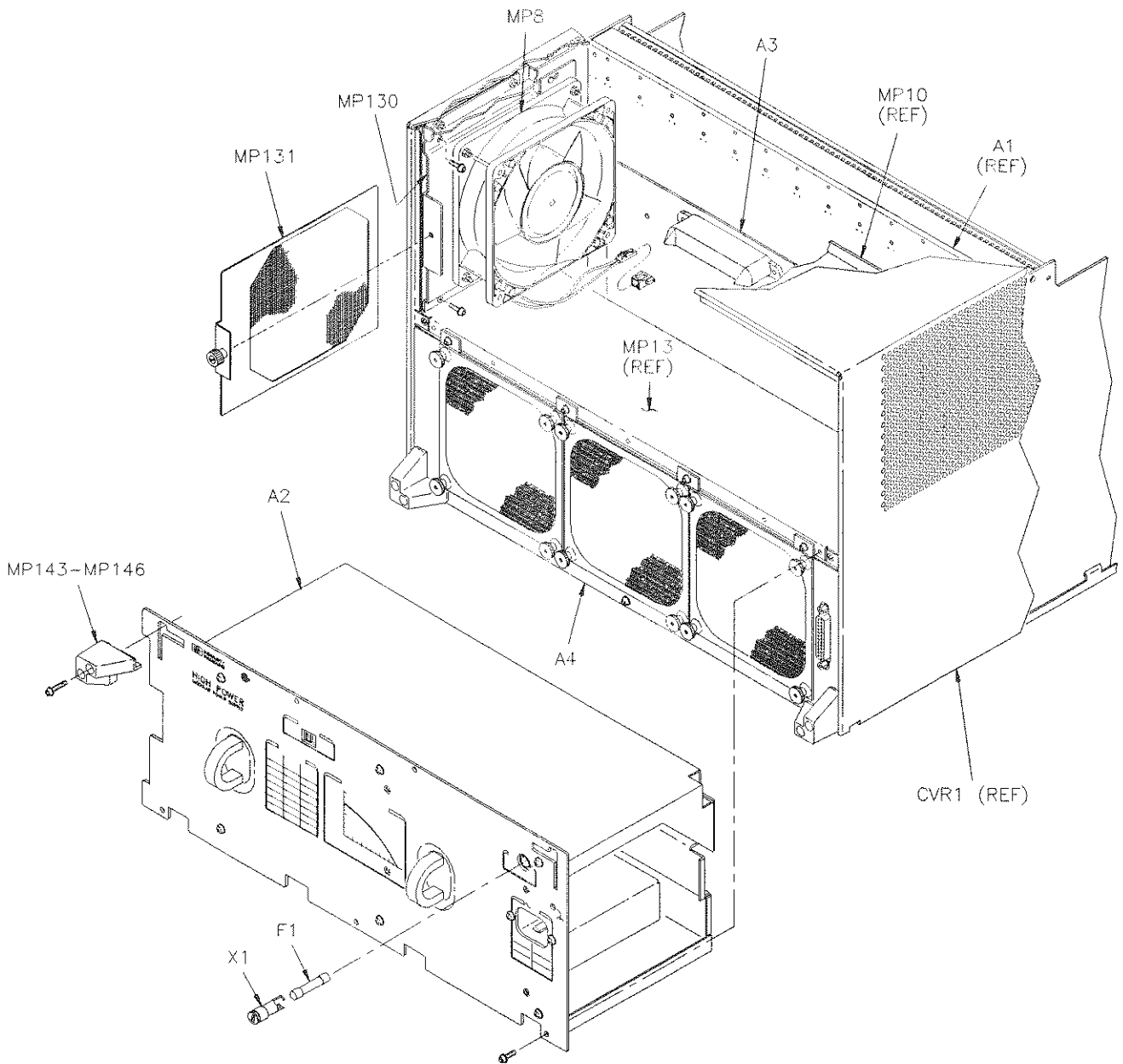

Figure B-1.



E1401 F_B_2

Figure B-2.

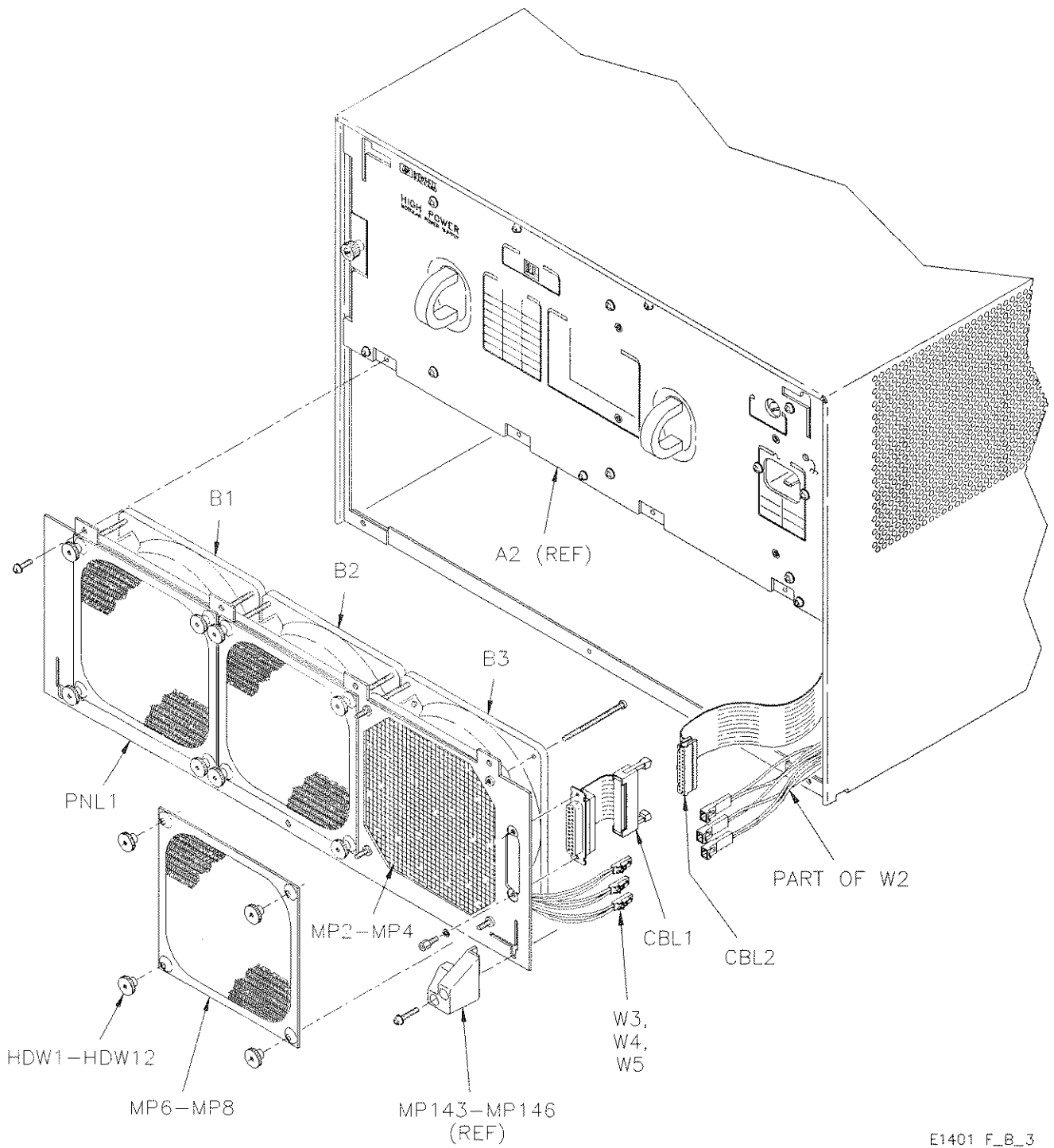
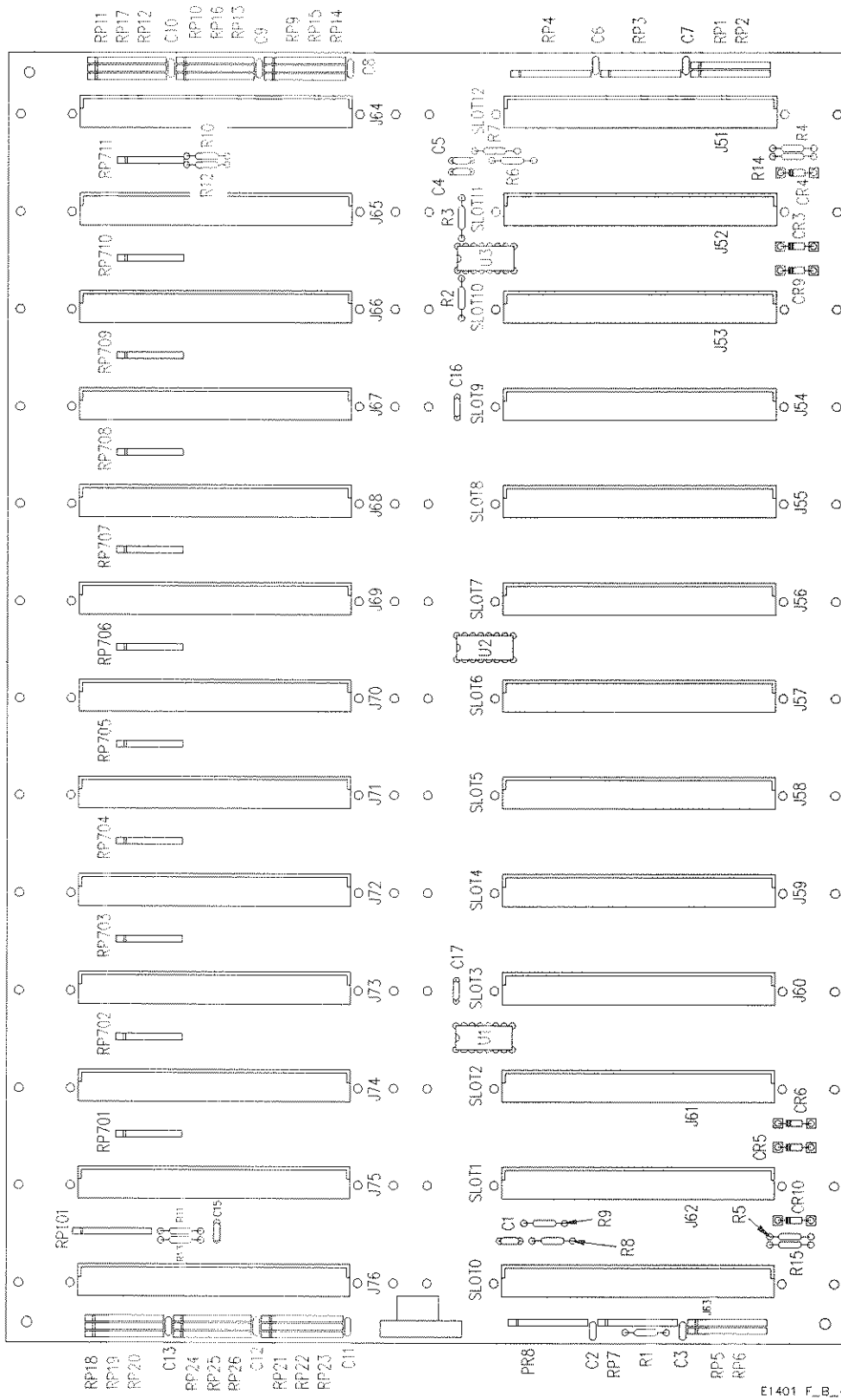

Figure B-3.

Table B-2 lists the HP E1401 backplane assembly components. To order a part, contact the vendor listed under Mfg. Code (see Table B-4 for a list of manufacturer's) and quote the mfr. part number, desired quantity, and the description.

Table B-2. HP E1401-66501 Backplane Assembly Parts List

Reference Designator	HP Part Number	Total Qty.	Description	Mfr. Code	Mfr. Part Number
A1	E1401-66501	1	Backplane PC Assembly	28480	E1401-66501
C1 – C13	0160-4426	18	Capacitor-fxd 0.01 μ F, +-1% 100 V	04222	SR301A103FAAH
C15 – C17	0160-4426		Capacitor-fxd 0.01 μ F, +-1% 100 V	04222	SR301A103FAAH
C18 – C26	0160-0128	9	Capacitor-fxd 2.2 μ F, +-20% 50 V	04222	SR515E225MAAH
C27 – C28	0160-4426		Capacitor-fxd 0.01 μ F, +-1% 100 V	04222	SR301A103FAAH
C31	0160-4833	1	Capacitor-fxd 0.022 μ F, +-10% 100 V	04222	SA201C223KAAH
CR3 – CR6	1901-0743	6	Diode-Power Rectifier 400V 1A DO-41	71744	1N4004
CR9 – CR10	1901-0743		Diode-Power Rectifier 400V 1A DO-41	71744	1N4004
J3 – J26	E1400-82101	28	Power Tap-10 Pin Mount .1"X.3"	28480	E1400-82101
J51 – J76	E1400-82102	26	Connector-96 Pin DIN 41612	28480	E1400-82102
J78 – J81	E1400-82101		Power Tap-10 Pin Mount .1"X.3"	28480	E1400-82101
MP1 – MP2	0360-0037	2	Terminal-Sldr Lug Pl-Mtg for-#6-Scr	78584	902-016-C
P2	E1400-82106	1	Compliant Sq Pin .027"x.875"	28480	E1400-82106
PCB1	E1401-26501	1	PC Board - Blank	28480	E1401-26501
R1	0757-0421	3	Resistor 825 Ω , +-1% 1/8W	24546	CT4-1/8-T0-825R-F
R2 – R9	0757-0277	8	Resistor 49.9 Ω , +-1% 1/8W	28480	0757-0277
R10 – R11	0757-0415	2	Resistor 475 Ω , +-1% 1/8W	24546	CT4-1/8-T0-475R-F
R12 – R13	0757-0411	2	Resistor 332 Ω , +-1% 1/8W	24546	CT4-1/8-T0-332R-F
R14 – R15	0757-0421	3	Resistor 825 Ω , +-1% 1/8W	24546	CT4-1/8-T0-825R-F
RP1 – RP26	1810-0759	26	Network-Res 10-SIP Multi-value	11236	750-105R330/470
RP101	1810-0280	1	Network-Res 10-SIP 10.0k Ω , X 9	91637	MSP10A01-103G 7 A1RP701 – RP711
U1 – U3	1820-2891	3	IC Gate ECL/10KH OR-NOR 2-INP	04713	MC10H101P
U701 – U717	1820-6934	17	IC-Gate CMOS/ACT OR QUAD	27014	74ACT32PC



E1401_F_B_4

Figure B-4. Component Side Backplane Component Diagram

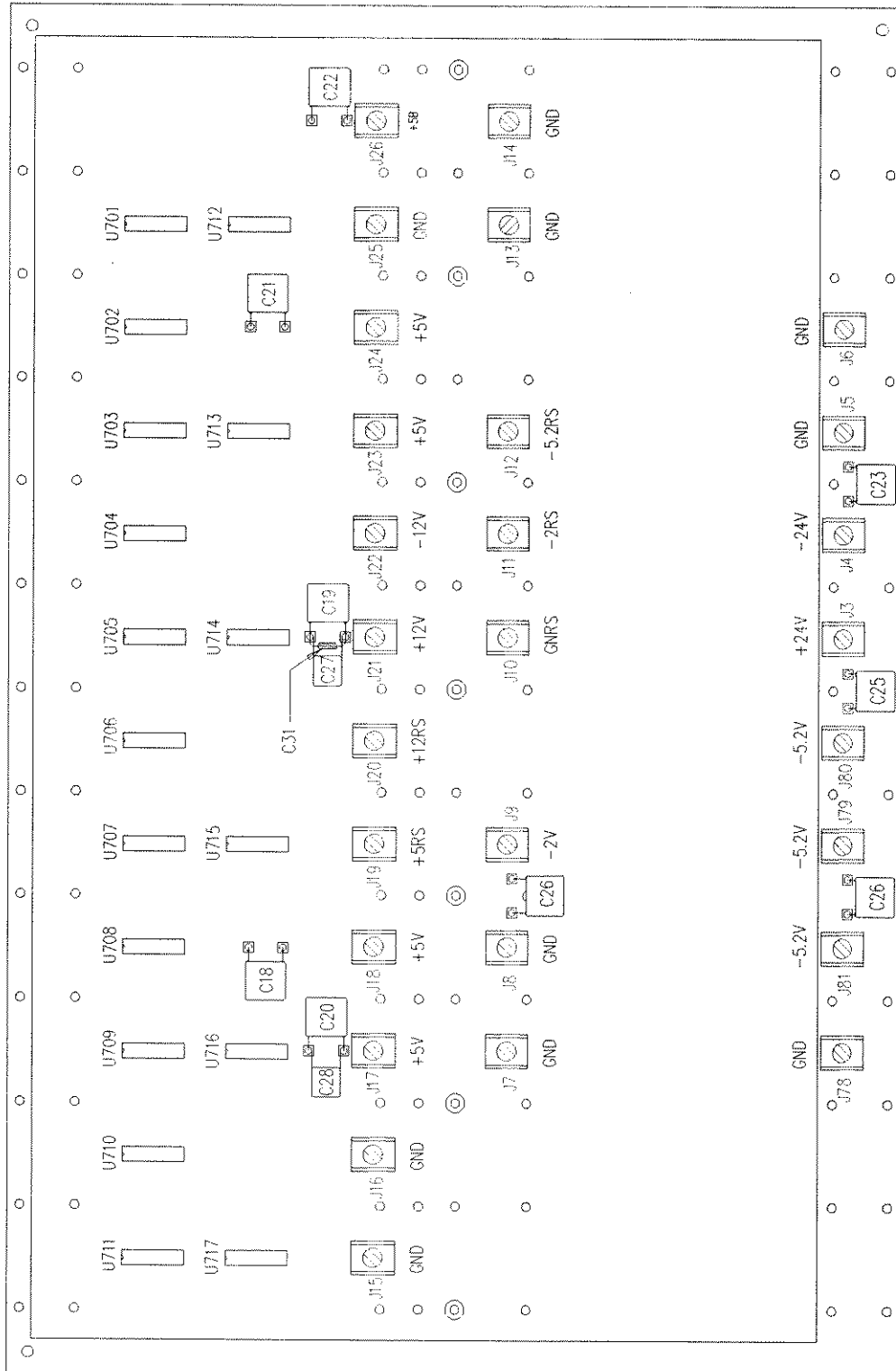

E1401 F_B_5

Figure B-5. Circuit Side Backplane Component Diagram

B-8 Replaceable Parts

Table B-3 lists the HP E1401 power interface board components. To order a part, contact the vendor listed under Mfg. Code (see Table B-4 for a list of manufacturer's) and quote the mfr. part number, desired quantity, and the description.

Table B-3. HP E1401-66502 Power Interface Board Parts List

Reference Designator	HP Part Number	Total Qty.	Description	Mfr. Code	Mfr. Part Number
A3	E1401-66502	1	PC Assembly Power Interface Bd	28480	E1401-66502
C1 - C3	0160-4835	7	Capacitor-fxd 0.1 μ F, +-10% 50 V	04222	SA105C104KAAH
C3 - C4	0180-4370	6	Capacitor-fxd 3300 μ F, +-20% 10 V	55680	TVX1A332MCE
C5	0160-4835		Capacitor-fxd 0.1 μ F, +-10% 50 V	04222	SA105C104KAAH
C6 - C7	0180-4370		Capacitor-fxd 3300 μ F, +-20% 10 V	55680	TVX1A332MCE
C8	0160-0128	2	Capacitor-fxd 2.2 μ F, +-20% 50 V	04222	SR515E225MAAH
C9 - C11	0160-4835		Capacitor-fxd 0.1 μ F, +-10% 50 V	04222	SA105C104KAAH
C14	0160-0128		Capacitor-fxd 2.2 μ F, +-20% 50 V	04222	SR515E225MAAH
C15	0160-4835		Capacitor-fxd 0.1 μ F, +-10% 50 V	04222	SA105C104KAAH
C20 - C21	0180-4370		Capacitor-fxd 3300 μ F, +-20% 10 V	55680	TVX1A332MCE
CR1 - CR7	1901-1087	7	Diode-Power Rectifier 600V 3A	04713	MR856
CR8 - CR19	1902-1356		Diode-Zener 36V 5% PD=1W	04713	1N4753ARL
JM1	7175-0057	1	Resistor 0 MFS	28480	7175-0057
P1	1252-4989	1	Connector-2X24 & 2X4 AMP	28480	1252-4989
P2	1252-4990	1	Drawer Connector w/Sense Lines	28480	1252-4990
P24	1252-4988	1	Connector-Post Type 13-Contact	27264	26-61-5130
P25	1252-3692	1	Connector-Post Type 2-Contact	27264	705-45-0071
P26	1252-2360	1	Connector-Post Type 26-Contact	76381	3429-5302
PCB1	E1401-26502	1	PC Board - Blank	28480	E1401-26502
R1 - R7	0757-0442	7	Resistor 10k Ω , +-1% 1/8W	24546	CT4-1/8-T0-1002-F
RT1 - RT3	0837-0400	3	Thermistor-Switching; Radial	06090	RXE110

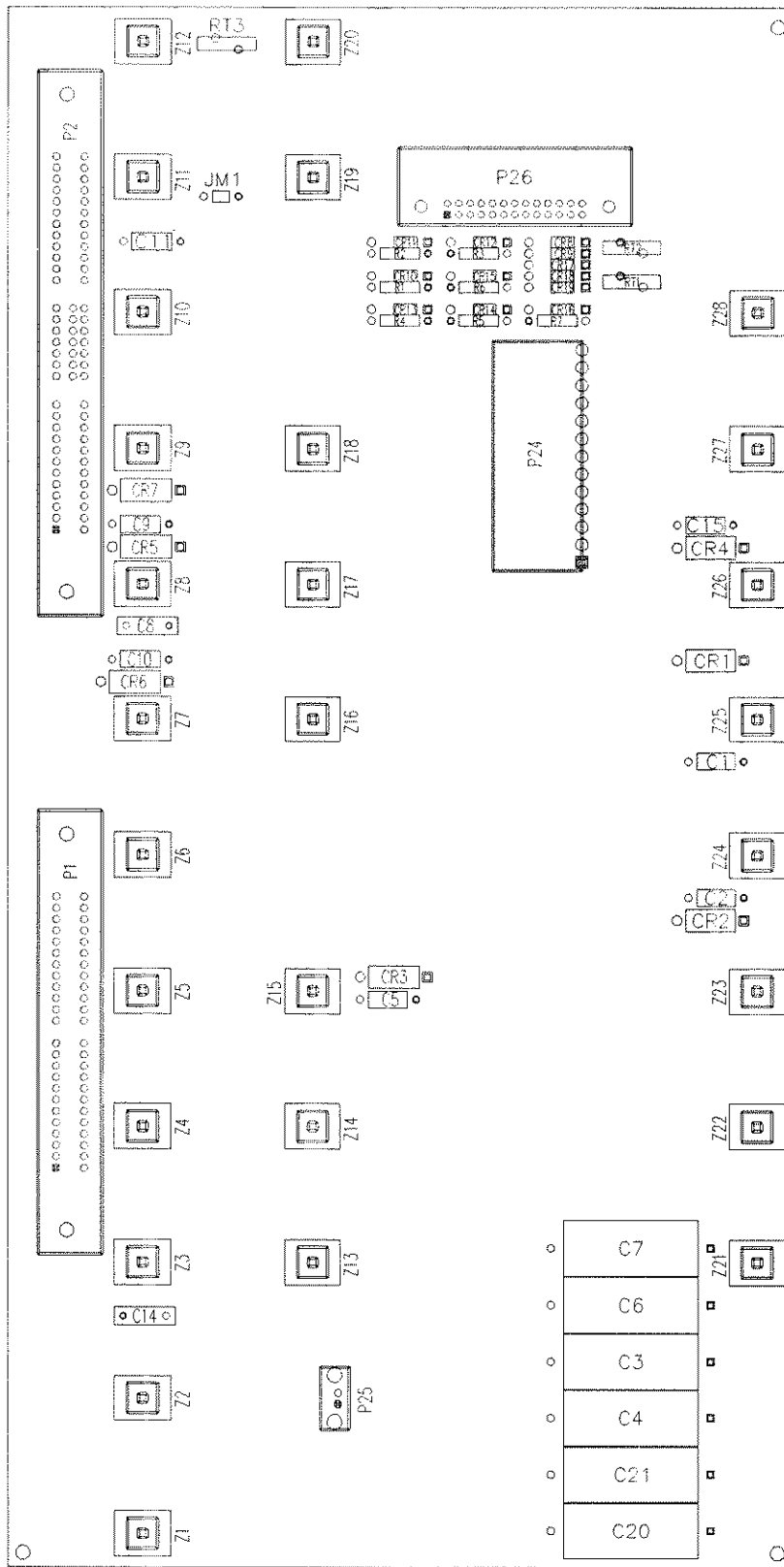

E1401 F_B_6

Figure B-6. Power Supply Interface Board Components

Table B-4 lists the vendors to contact if a replacement part is needed.

Table B-4. HP E1401 Code List of Manufacturer's

Mfr. Code	Manufacturer's Name	Manufacturer's Address	Zip Code
01295	Texas Instruments Inc	Dallas, TX USA	75265
04222	AVX Corp	Great Neck, NY USA	11021
04713	Motorola Inc	Roselle, IL USA	60195
06090	Raychem Corp	Menlo Park, CA USA	94025
06776	Robinson Nugent Inc	New Albany, IN USA	47150
11236	CTS Corp	Elkhart, IN USA	46514
16428	Cooper Industries Inc	Houston, TX USA	77210
18324	Signetics Corp	Sunnyvale, CA USA	94086
18873	DuPont E I De Nemours & Co.	Wilmington, DE USA	19801
24546	Corning Glass Works	Corning, NY USA	14830
26742	Methode Electronics Inc	Chicago, IL USA	60656
27014	National Semiconductor Corp	Santa Clara, CA USA	95052
27264	Molex Inc	Lisle, IL USA	60532
28480	Hewlett-Packard Company - Corporate	Palo Alto, CA USA	94304
34371	Harris Corp	Melbourne, FL USA	32901
50088	SGS-Thomson Microelectronics Inc	Phoenix, AZ USA	85022
55680	Nichicon (America) Corp	Schaumburg, IL USA	60195
56289	Sprague Electric Co.	Lexington, MA USA	02173
71744	General Instrument Corp	Clifton, NJ USA	07012
75915	Littelfuse Inc	Des Plaines, IL USA	60016
76381	3M Co	St Paul, MN USA	55144
78584	Stewart Stamping Corp	Yonkers, NY USA	10704
81073	Grayhill Inc.	La Grange, IL USA	60525
91637	Dale Electronics Inc	Columbus, NE USA	68601

Removing the Power Supply Fan Filter

You can remove the Power Supply Fan Filter for cleaning without removing any other component from the back of the High-Power Mainframe.

1. Unscrew the captive thumbscrew that secures the filter.
2. Pull the filter out of its slot
3. Clean the filter.
4. Replace the filter into its slot
5. Secure the filter with the captive thumbscrew.

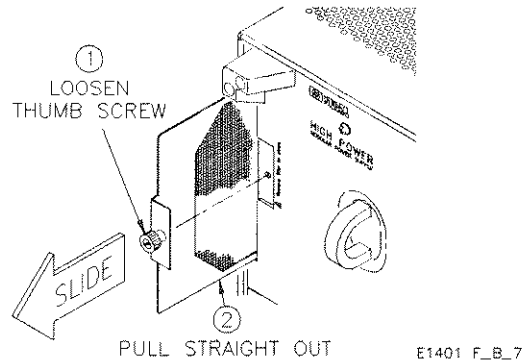

Figure B-7. Removing the Power Supply Fan Filter

Removing the Mainframe Fan Filters

You can remove the Mainframe Fan Filters for cleaning without removing any other component from the back of the High-Power Mainframe.

1. Unscrew the four thumbnuts that secure the filter.
2. Pull the filter off of the four bolts that secure the fan.
3. Clean the filter.
4. Replace the filter onto its four bolts
5. Secure the filter with the four thumbnuts.

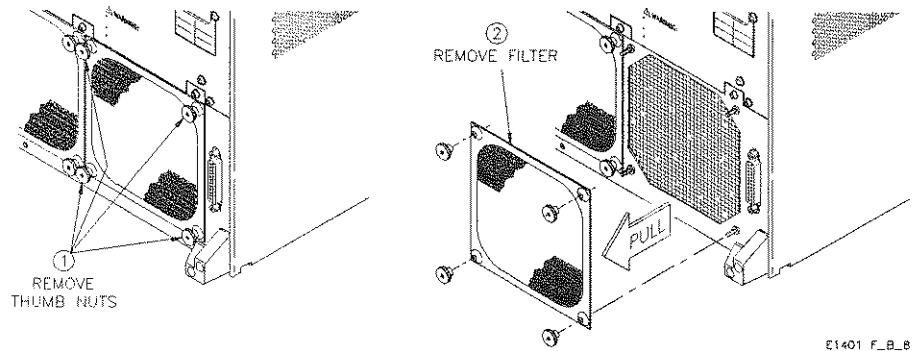

Figure B-8. Removing the Mainframe Fan Filters.

Removing the Power Supply

You can remove the Power Supply for maintenance without removing any other component from the back of the High-Power Mainframe. Installation is the reverse of removal. You will need a Torx T10 screwdriver.

WARNING

To prevent possible electrical shock, disconnect power cord before removing the power supply from the mainframe.

ADVERTISSEMENT

Pour réduire les risques de choc électrique, débranchez le bloc d'alimentation avant de le retirer du processeur central.

1. Remove the two upper rear feet from the rear of the High-Power Mainframe.
 2. Remove two Torx screws that secure the upper edge of the power supply.
 3. Remove three Torx screws that secure the lower edge of the Power Supply
 4. Using the two handles provided on the rear of the Power Supply, pull it directly out the rear of the High-Power mainframe.
-

CAUTION

Do not use the power supply handles located on the rear panel to lift the mainframe.

ADVERTISSEMENT

Ne pas utiliser les poignées du bloc d'alimentation, situées sur le panneau arrière, pour lever le processeur central.

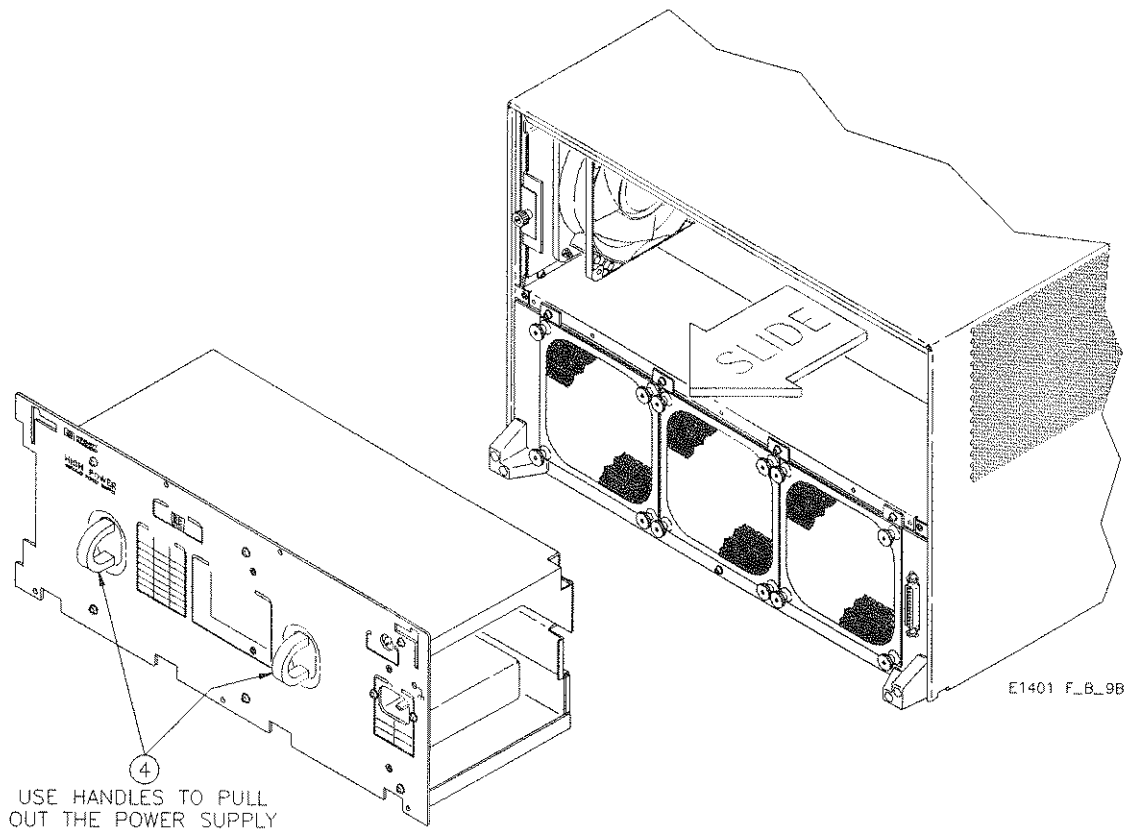
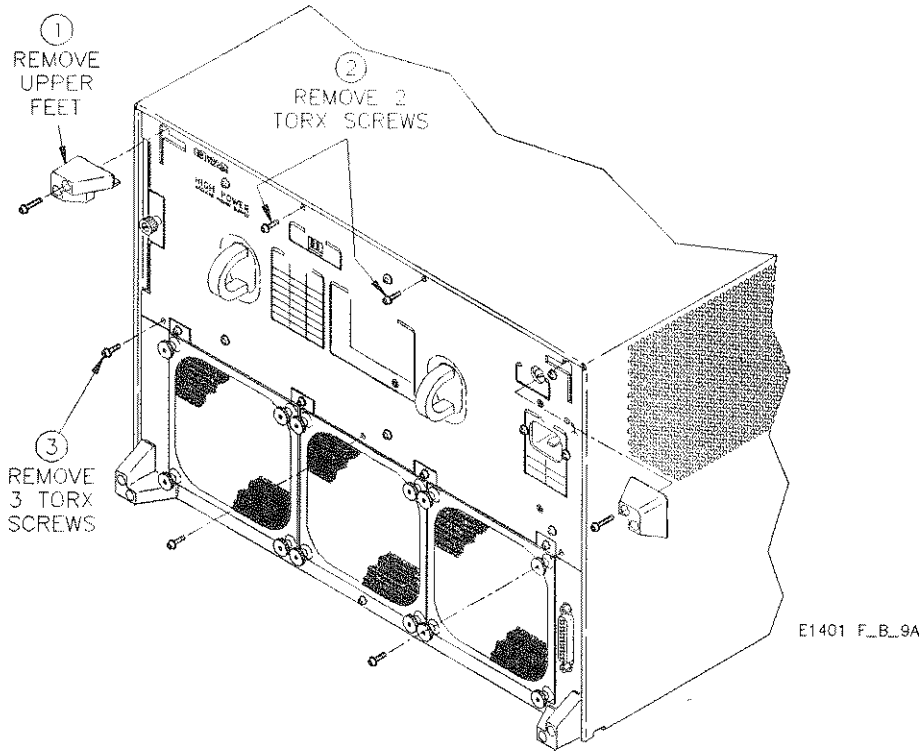

Figure B-9. Removing the Power Supply

Removing the Power Supply Fan

The Power Supply fan can be removed once you have removed the Power Supply and the Power Supply Fan Filter from the High-Power Mainframe. Installation is the reverse of removal.

1. Remove the Power Supply
2. Remove the Power Supply Fan Filter.
3. Disconnect the fan cable from the power interface board.
4. Remove two torx screws that secure the rear side of the Power Supply Fan Bracket to the High-Power mainframe.
5. Grasp the Power Supply Fan assembly and pull it gently towards the rear of the High-Power Mainframe.
6. Pull the entire assembly to your right to release the front edge of the fan assembly from the screws that hold it onto the High-Power Mainframe.

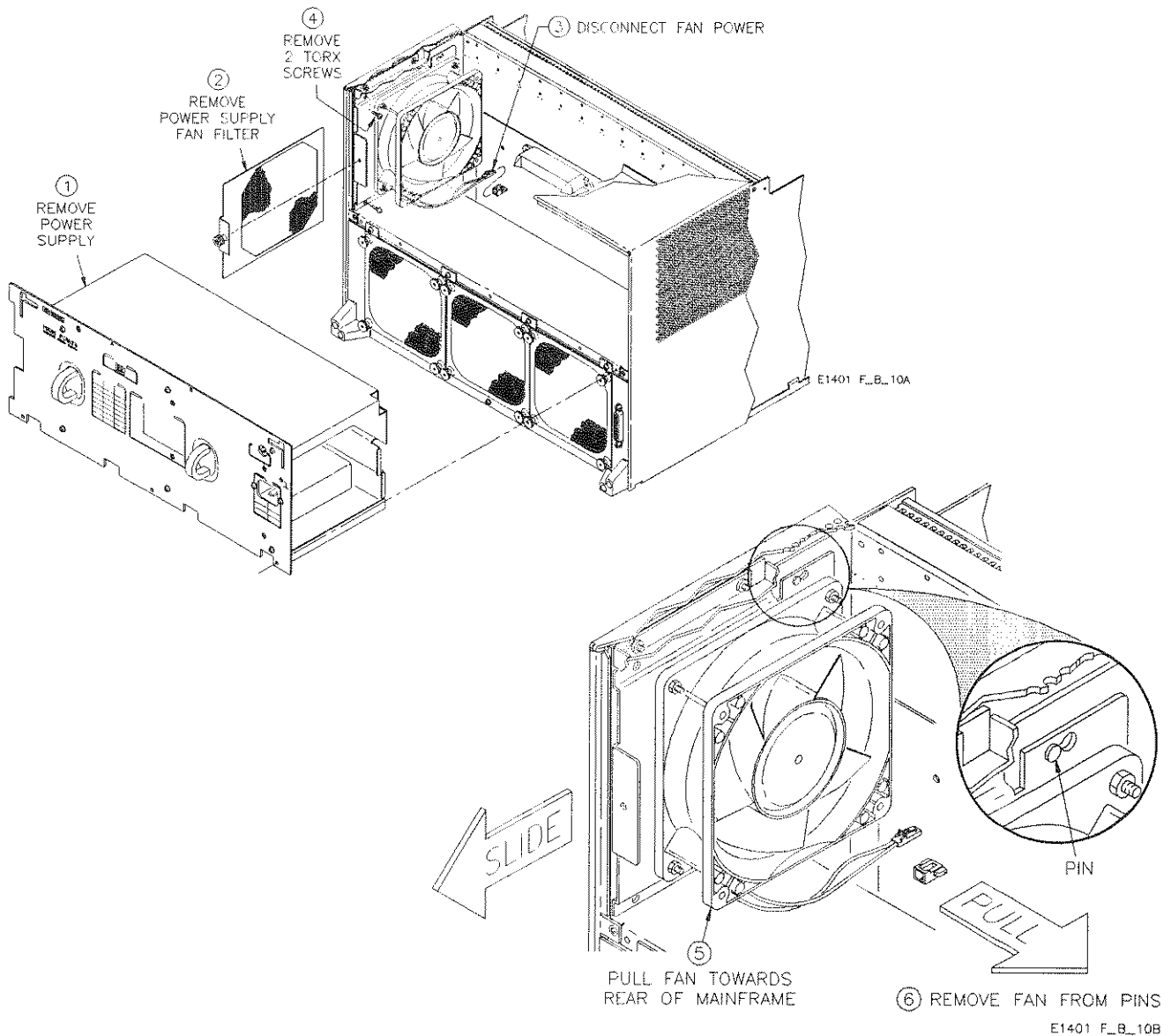

Figure B-10. Removing the Power Supply Fan

Removing the Mainframe Fan Assembly

The High-Power Mainframe has three fans in its fan assembly. You can remove the entire fan assembly without removing any other component from the rear of the High-Power Mainframe except the mainframe Fan Filters which are actually part of the assembly. Installation is the reverse of removal. You will need a Torx T10 screwdriver.

1. Remove the two lower rear feet from the rear of the High-Power Mainframe.
2. Remove four Torx screws that secure the upper edge of the Fan Assembly.
3. Remove one Torx screw that secures the lower edge of the fan assembly.
4. Pull the fan assembly out of the mainframe.
5. Disconnect the fan power cord from the cable that connects it to the mainframe.
6. Disconnect the auxiliary plug from the ribbon cable that connects it to the mainframe.

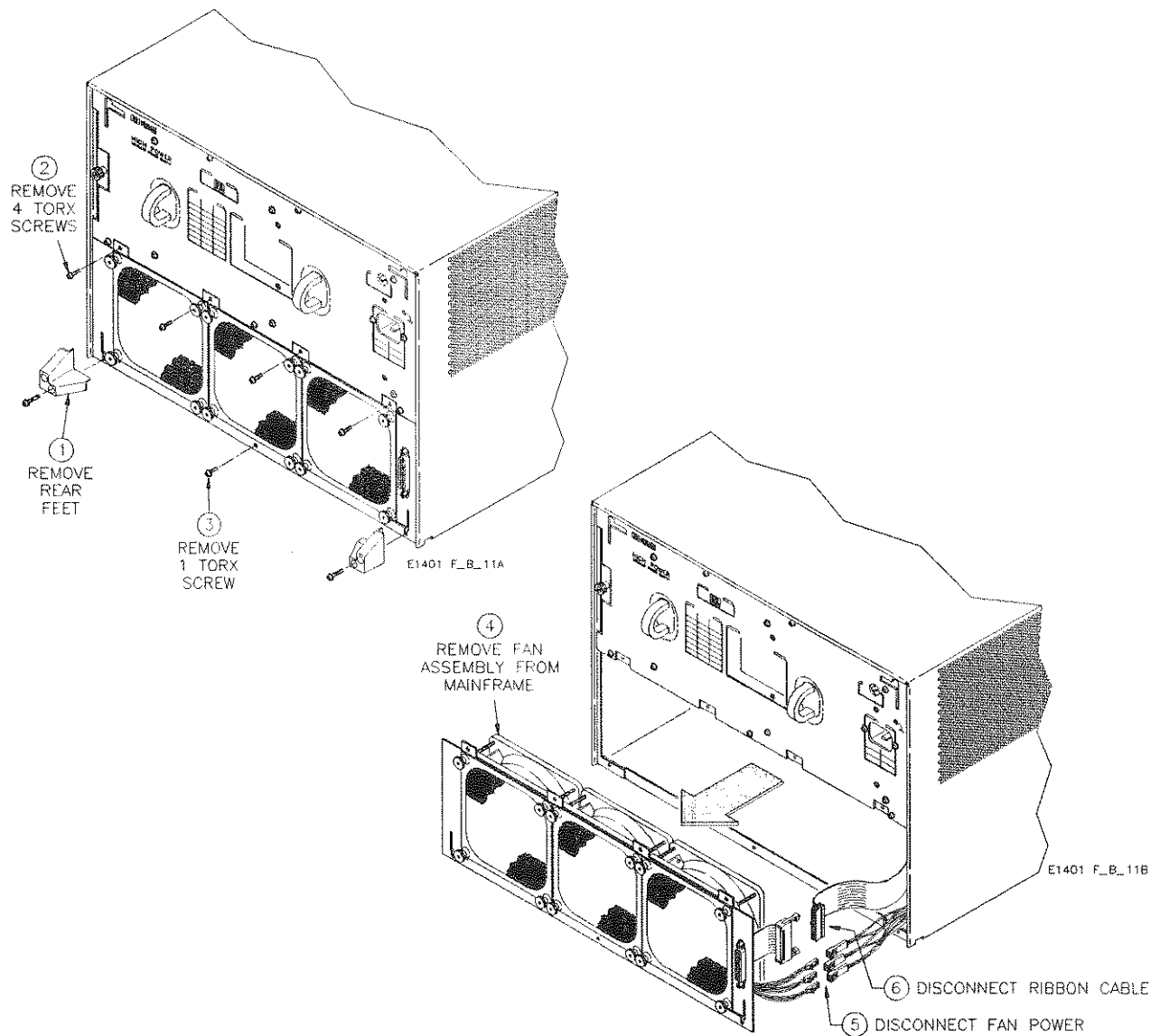

Figure B-11. Removing the Mainframe Fans

Replacing a Lower Plastic Module Guide

The lower plastic module guides are single piece units that can be easily replaced if required. Refer to figure B-12.

Removal

1. Insert a flat blade screwdriver into the slot at the front of the module guide and pry up until it unsnaps from the front rail of the chassis.
2. Grasp the front end of the guide and pull up until two (2) pins at the front of the guide are clear of the holes in the rail.
3. Pull the guide towards you to release the hooks that engage holes and undercuts in the three (3) remaining rails that support the guide.

Installation

4. Align the left edge of the guide you are going to install with the right edge of the adjacent guide. If there is no adjacent guide, align the guide between slot marks on the lower front bezel. Sight along one edge of the guide to make sure that it is at right angles to the frame rails. When properly positioned, the air inlet holes will align with the left inside wall of the module guide as shown in figure B-12.
5. Make sure that the rear three (3) sets of pins are inserted into their holes in the three rearmost rails, and that the guide is now low enough to rest directly on top of the rear rail.
6. Force the guide to bend down against second rail.
7. Push the guide back slightly to engage the three (3) tabs on the guide under their notches in the three rear rails.
8. Push down at the front of the guide to insert the front pair of pins into holes in the front rail and snap the guide into place. The guide should now be firmly seated, and should rest directly on top of all four rails.

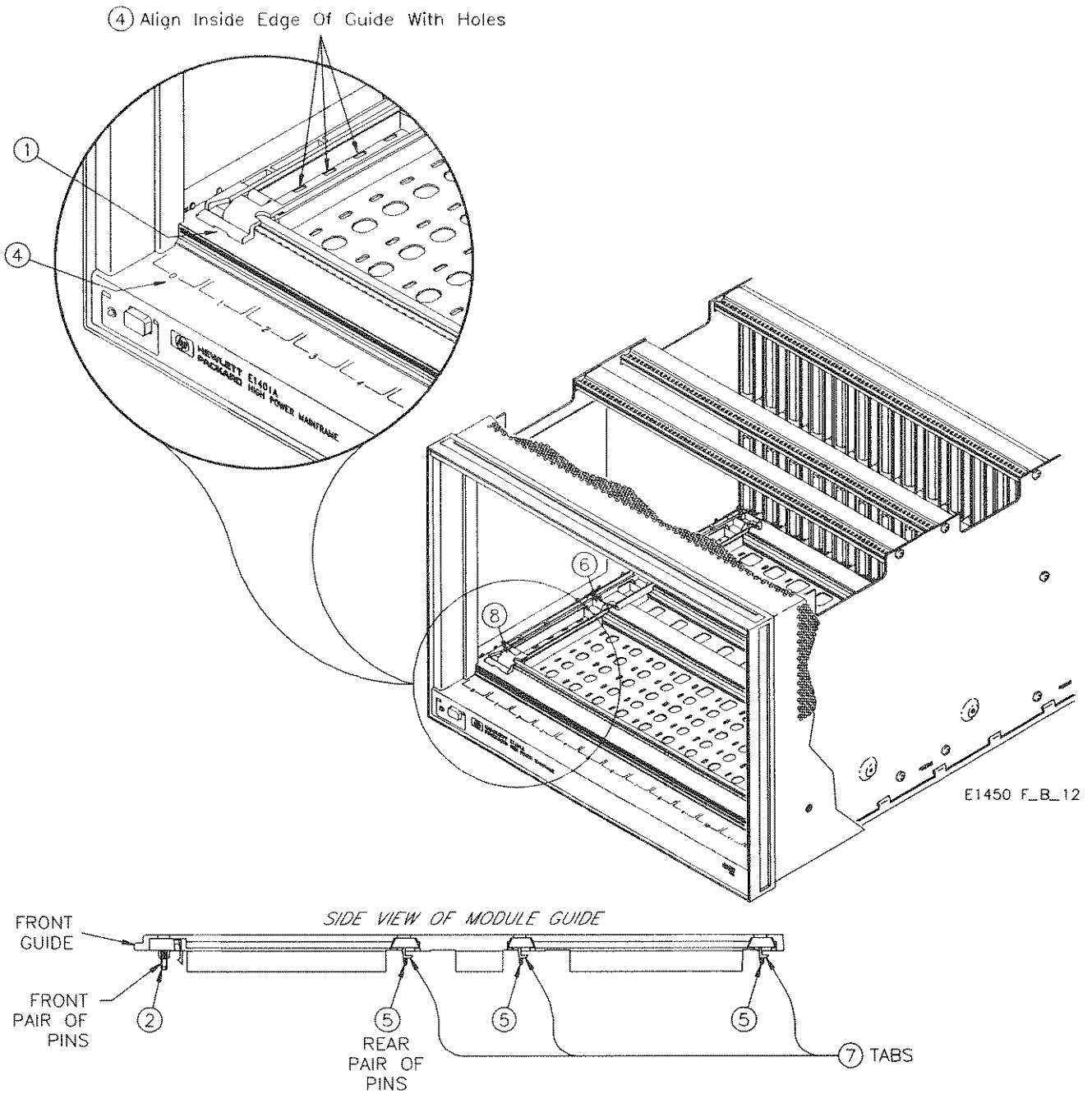

Figure B-12. Replacing a Lower Module Guide

Replacing an Upper Plastic Module Guide

The upper plastic module guide consists of two identical guides mounted one in front of the other

Removal

Grasp the module guide you wish to remove and pull it straight down, snapping it out of its retaining holes. If you are replacing the two guides that make a single slot, you should replace them one at a time if possible, since it will be easier to align the new guide.

Installation

1. Orient the new guide as shown in figure B-13.
2. If possible, align the guide with the guide remaining in the same slot, either in front of or behind the guide you are going to install. If you cannot align the new guide with an existing guide, align the guide groove with the left edge of the backplane connector for the slot as shown in figure B-13.
3. Push the guide up to snap it into place in the notches of the mainframe rails.

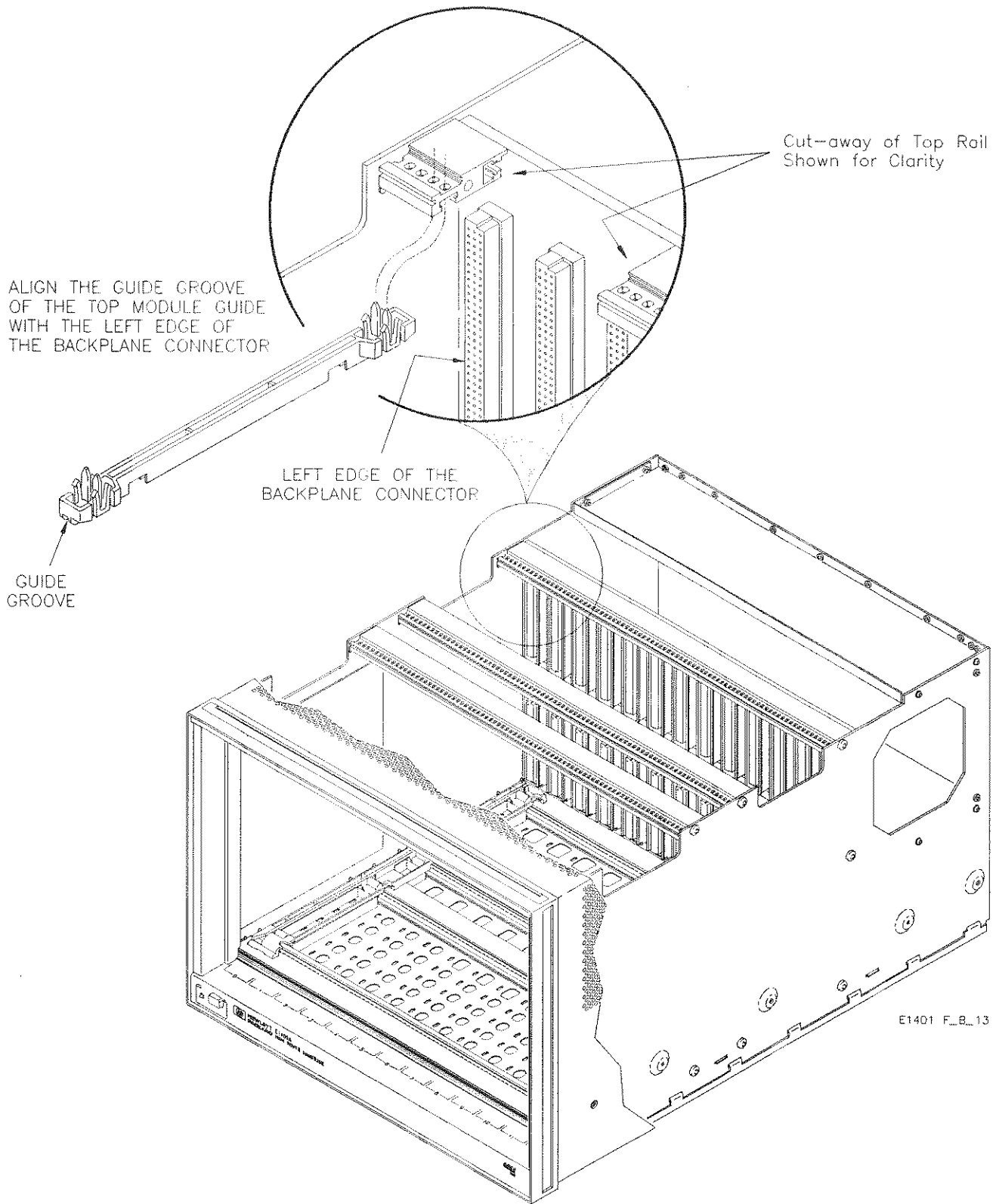

Figure B-13. Replacing an Upper Module Guide

Index

+12V 3-5
 +5V 3-4
 +5VSTDBY 3-5

A

A-Size and B-Size modules
 installing 2-5
 ACFAIL* 3-5
 Acoustical noise A-5
 Auxiliary connector 3-3
 using 3-1 - 3-6

B

Backplane connector shield
 using 2-7
 Backplane description 2-1
 Backplane voltage pinouts 3-2
 Bracket
 Power Cord 1-4

C

C-Size modules
 installing 2-5
 Chassis shield
 using 2-7
 Classification A-5
 Control
 Variable-speed fan 2-4
 Cooling capacity
 mainframe 2-2
 Cooling provided A-4

D

Description
 backplane 2-1
 hardware 2-1 - 2-8
 mainframe 1-1
 mainframe cooling system 2-2

E

EMC testing A-5
 EXHAUST_TEMP 3-5

F

Faceplate panels
 using 2-7
 Fan filters
 removing B-12

G

Getting started 1-1 - 1-4

H

Hardware description 2-1 - 2-8
 Humidity A-4

I

Input power A-2
 Installing
 lower module guide B-17
 mainframe fan assembly B-16
 mainframe fan filters B-12
 power supply B-13
 power supply fan B-15
 power supply fan filter B-12
 upper module guide B-19
 Installing A-Size and B-Size modules 2-5
 Installing C-Size modules 2-5
 Installing modules 2-5
 Installing the line power fuse 1-2

L

Line power fuse
 installing 1-2
 Line voltage
 setting 1-2
 Lower module guide B-17

M

Mainframe	
rack mounting	2-7
removing & installing the fan assembly	B-16
removing & installing the fan filters	B-12
Mainframe cooling capacity	2-2
Mainframe cooling system description	2-2
Mainframe description	1-1
Mainframe fan assembly	B-16
Mainframe hardware description	2-1 - 2-8
Mainframe power supplies	
using	3-1 - 3-6
Mainframe size	A-1
Mainframe weight	A-1
Maximum power output	A-3
Maximum power ratings	3-1
Module guide	
Lower	B-17
upper	B-19
Module size	A-1
Module weight	A-5
Modules	
installing	2-5
replacement	B-1
requirements for	2-4

O

Output	
maximum power	A-3
Outputs	
power supply	A-2

P

Parts	B-1
Plug-in module design	2-6
Plug-in module selection	2-6
Power	
+12V	3-5
+5V	3-4
+5VSTDBY	3-5
input	A-2
maximum ratings	3-1
Power cords	1-3
Power supply	
maximum power output	A-3
outputs	A-2
removing and installing	B-13
removing and installing the fan	B-15
removing and installing the fan filter	B-12
using	3-2
Power supply fan	B-15
Power supply fan filter	B-12

R

Rack mounting the mainframe	2-7
Rear panel auxiliary connector	3-3
Remote standby switch	3-4
Removing	
lower module guide	B-17
mainframe fan assembly	B-16
mainframe fan filters	B-12
power supply	B-13
power supply fan	B-15
power supply fan filter	B-12
upper module guide	B-19
Replaceable modules	B-1
Replaceable parts	B-1
Replacing a lower module guide	B-17
Replacing an upper module guide	B-19
Requirements for modules	2-4
Ripple/Noise	A-3

S

Safety	A-5
Setting the line voltage	1-2
Shock and vibration	A-4
Size	
module	A-1
Size:mainframe	A-1
Specification	
acoustical noise	A-5
cooling provided	A-4
EMC testing	A-5
humidity	A-4
input power	A-2
mainframe weight	A-1
maximum power output	A-3
module size	A-1
module weight	A-5
power supply outputs	A-2
safety	A-5
shock and vibration	A-4
temperature range	A-4
VXI Ripple/Noise	A-3
Specification:classification	A-5
Specification:mainframe size	A-1
Switch	
remote standby	3-4
SYSRESET*	3-5

T

Temperature range	A-4
-------------------	-----

U

Upper module guide	B-19
Using	
a backplane connector shield	2-7
a chassis shield	2-7
power supply outputs	3-2
the auxiliary connector	3-1 - 3-6
Using faceplate panels	2-7
Using mainframe power supplies	3-1 - 3-6

V

Variable-speed fan control	2-4
Vibration and shock	A-4
VXI Ripple/Noise	A-3

W

Weight	
mainframe	A-1
module	A-5

