

HP 8924C CDMA Mobile Station Test Set

Application Guide

Firmware Version A.06.25 and above

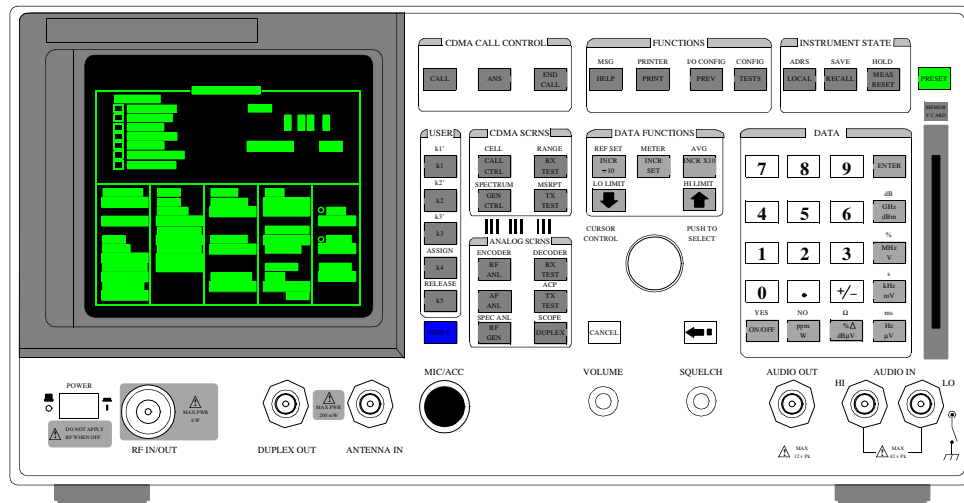

HP Part No. 08924-90021
Printed in U. S. A.
December 1998

Rev. G

Copyright © Hewlett-Packard Company 1995

Notice

Information contained in this document is subject to change without notice.

All Rights Reserved. Reproduction, adaptation, or translation without prior written permission is prohibited, except as allowed under the copyright laws.

This material may be reproduced by or for the U.S. Government pursuant to the Copyright License under the clause at DFARS 52.227-7013 (APR 1988).

Hewlett-Packard Company
Learning Products Department
24001 E. Mission
Liberty Lake, WA 99019-9599
U.S.A.

Manufacturer's Declaration

This statement is provided to comply with the requirements of the German Sound Emission Directive, from 18 January 1991.

This product has a sound pressure emission (at the operator position) < 70 dB(A).

- Sound Pressure $L_p < 70$ dB(A).
- At Operator Position.
- Normal Operation.
- According to ISO 7779:1988/EN 27779:1991 (Type Test).

Herstellerbescheinigung

Diese Information steht im Zusammenhang mit den Anforderungen der Maschinenlärminformationsverordnung vom 18 Januar 1991.

- Schalldruckpegel $L_p < 70$ dB(A).
- Am Arbeitsplatz.
- Normaler Betrieb.
- Nach ISO 7779:1988/EN 27779:1991 (Typprüfung).

Safety Considerations

GENERAL

This product and related documentation must be reviewed for familiarization with safety markings and instructions before operation.

This product has been designed and tested in accordance with *IEC Publication 1010*, "Safety Requirements for Electronic Measuring Apparatus," and has been supplied in a safe condition. This instruction documentation contains information and warnings which must be followed by the user to ensure safe operation and to maintain the product in a safe condition.

SAFETY EARTH GROUND

A uninterruptible safety earth ground must be provided from the main power source to the product input wiring terminals, power cord, or supplied power cord set.

CHASSIS GROUND TERMINAL

To prevent a potential shock hazard, always connect the rear-panel chassis ground terminal to earth ground when operating this instrument from a dc power source.

SAFETY SYMBOLS



Indicates instrument damage can occur if indicated operating limits are exceeded.



Indicates hazardous voltages.



Indicates earth (ground) terminal

WARNING

A WARNING note denotes a hazard. It calls attention to a procedure, practice, or the like, which, if not correctly performed or adhered to, could result in personal injury. Do not proceed beyond a WARNING sign until the indicated conditions are fully understood and met.

CAUTION

A CAUTION note denotes a hazard. It calls attention to an operation procedure, practice, or the like, which, if not correctly performed or adhered to, could result in damage to or destruction of part or all of the product. Do not proceed beyond a CAUTION note until the indicated conditions are fully understood and met.

Safety Considerations for this Instrument

WARNING

This product is a Safety Class I instrument (provided with a protective earthing ground incorporated in the power cord). The mains plug shall only be inserted in a socket outlet provided with a protective earth contact. Any interruption of the protective conductor inside or outside of the product is likely to make the product dangerous. Intentional interruption is prohibited..

Whenever it is likely that the protection has been impaired, the instrument must be made inoperative and be secured against any unintended operation.

If this instrument is to be energized via an autotransformer (for voltage reduction), make sure the common terminal is connected to the earth terminal of the power source.

If this product is not used as specified, the protection provided by the equipment could be impaired. This product must be used in a normal condition (in which all means for protection are intact) only.

No operator serviceable parts in this product. Refer servicing to qualified personnel. To prevent electrical shock, do not remove covers.

Servicing instructions are for use by qualified personnel only. To avoid electrical shock, do not perform any servicing unless you are qualified to do so.

The opening of covers or removal of parts is likely to expose dangerous voltages. Disconnect the product from all voltage sources while it is being opened.

Adjustments described in the manual are performed with power supplied to the instrument while protective covers are removed. Energy available at many points may, if contacted, result in personal injury.

The power cord is connected to internal capacitors that may remain live for 5 seconds after disconnecting the plug from its power supply.

For Continued protection against fire hazard, replace the line fuse(s) only with 250 V fuse(s) or the same current rating and type (for example, normal blow or time delay). Do not use repaired fuses or short circuited fuseholders.

CAUTION:

Always use the three-prong ac power cord supplied with this product. Failure to ensure adequate earth grounding by not using this cord may cause product damage.

This product is designed for use in Installation Category II and Pollution Degree 2 per *IEC 1010* and *IEC 664* respectively.

This product has autoranging line voltage input, be sure the supply voltage is within the specified range.

Ventilation Requirements: When installing the product in a cabinet, the convection into and out of the product must not be restricted. The ambient temperature (outside the cabinet) must be less than the maximum operating temperature of the product by 4° C for every 100 watts dissipated in the cabinet. If the total power dissipated in the cabinet is greater than 800 watts, then forced convection must be used.

Product Markings

CE - the CE mark is a registered trademark of the European Community. A CE mark accompanied by a year indicated the year the design was proven.

CSA - the CSA mark is a registered trademark of the Canadian Standards Association.

CERTIFICATION	<i>Hewlett-Packard Company certifies that this product met its published specifications at the time of shipment from the factory. Hewlett-Packard further certifies that its calibration measurements are traceable to the United States National Institute of Standards and Technology, to the extent allowed by the Institute's calibration facility, and to the calibration facilities of other International Standards Organization members</i>
WARRANTY	<p>This Hewlett-Packard instrument product is warranted against defects in material and workmanship for a period of one year from date of shipment. During the warranty period, Hewlett-Packard Company will at its option, either repair or replace products which prove to be defective.</p> <p>For warranty service or repair, this product must be returned to a service facility designated by HP. Buyer shall prepay shipping charges to HP and HP shall pay shipping charges, duties, and taxes for products returned to HP from another country.</p> <p>HP warrants that its software and firmware designated by HP for use with an instrument will execute its programming instructions when properly installed on that instrument. HP does not warrant that the operation of the instrument, or software, or firmware will be uninterrupted or error free.</p>
LIMITATION OF WARRANTY	<p>The foregoing warranty shall not apply to defects resulting from improper or inadequate maintenance by Buyer, Buyer-supplied software or interfacing, unauthorized modification or misuse, operation outside of the environmental specifications for the product, or improper site preparation or maintenance.</p> <p>NO OTHER WARRANTY IS EXPRESSED OR IMPLIED. HP SPECIFICALLY DISCLAIMS THE IMPLIED WARRANTIES OF MERCHANTABILITY AND FITNESS FOR A PARTICULAR PURPOSE.</p>
EXCLUSIVE REMEDIES	<p>THE REMEDIES PROVIDED HEREIN ARE BUYER'S SOLE AND EXCLUSIVE REMEDIES. HP SHALL NOT BE LIABLE FOR ANY DIRECT, INDIRECT, SPECIAL, INCIDENTAL, OR CONSEQUENTIAL DAMAGES, WHETHER BASE ON CONTRACT, TORT, OR ANY OTHER LEGAL THEORY.</p>
ASSISTANCE	<i>Product maintenance agreements and other customer assistance agreements are available for Hewlett-Packard products. For any assistance, contact your nearest Hewlett-Packard Sales and Service Office.</i>

DECLARATION OF CONFORMITY

according to ISO/IEC Guide 22 and EN 45014

Manufacturer's Name: **Hewlett-Packard Co.**

Manufacturer's Address: **Spokane Division
24001 E. Mission Avenue
Liberty Lake, Washington 99019-9599
USA**

declares that the product

Product Name: **CDMA Mobile Station Test Set**

Model Number: **HP 8924C**

Product Options: **This declaration covers all options of the above product.**

conforms to the following Product specifications:

Safety: **IEC 1010-1:1990+A1 / EN 61010-1:1993**

EMC: **CISPR 11:1990/EN 55011:1991- Group 1, Class A
EN 50082-1 : 1992
IEC 801-2:1991 - 4kV CD,8kV AD
IEC 801-3:1984 3V/m
IEC 801-4:1988 0.5 kV Sig. Lines, 1 kV Power Lines**

Supplementary Information:

This product herewith complies with the requirements of the Low Voltage Directive 73/23/EEC and the EMC Directive 89/336/EEC and carries the CE-marking accordingly.

Spokane, Washington USA October 17, 1996



Vince Roland
Reliability & Regulatory
Engineering Manager

European Contact: Your local Hewlett-Packard Sales and Service Office or Hewlett-Packard GmbH
Department ZQ/Standards Europe, Herrenberger Strasse 130, D-71034 Böblingen, Germany (FAX+49-7031-14-3143)

Contents

1 Calibrating the Test Set

Calibration Procedures 24

Guidelines: 24

Recommended Calibration Procedures: 25

Calibrating CDMA Channel Levels 26

Calibrating Channel Power Measurements 29

Procedure Overview 33

Calibrating RF Generator Levels 35

Zeroing Average Power Measurements 36

Procedure Overview 40

Correcting for RF Path Loss 41

Determining RF Path Loss 44

Procedure Prerequisites 44

Procedure Overview 50

Contents

2 Setting Up a Call

Setting up a Call 52

Procedure Overview 66

Problem Solving 68

Checklist 1. MSUT did not find service 68

Checklist 2. Registration failed 70

Contents

3 CDMA Receiver Tests

List of CDMA Receiver Tests 72

Measuring Demodulation of Forward Traffic Channel with
AWGN 73

Test Prerequisites 73

Measurement Overview 82

HPBASIC Programming Example 83

Measuring Receiver Sensitivity and Dynamic Range 87

Measurement Overview 95

HPBASIC Programming Example 96

Measuring Single Tone Desensitization 99

Test Prerequisites 99

Recommended Equipment 99

Measurement Overview 110

Programming Example 111

Measuring Intermodulation Spurious Response Attenuation 115

Test Prerequisites 115

Recommended Equipment 115

Measurement Overview 126

Measuring Demodulation of Non-Slotted Mode Paging Channel in
AWGN 128

Test Prerequisites 128

Measurement Overview 136

4 CDMA Transmitter Tests

List of CDMA Transmitter Tests 140

Measuring Waveform Quality 141

Measurement Overview 147

HPBASIC Program Example 148

Measuring Minimum/Maximum Power 150

Test Prerequisites 150

Measurement Overview 153

Measuring Maximum RF Output Power 154

Test Prerequisites 154

Measurement Overview 161

HPBASIC Programming Example 162

Measuring Minimum Controlled Output Power 164

Test Prerequisites 164

Measurement Overview 171

HPBASIC Programming Example 172

Measuring the Range of Open Loop Output Power 175

Test Prerequisites 175

Measurement Overview 183

HPBASIC Programming Example 184

Measuring Access Probe Output Power 186

Test Prerequisites 186

Recommended Equipment 186

Measurement Overview 195

HPBASIC Programming Example 196

Contents

5 CDMA to Analog Handoff

Performing a CDMA to Analog Handoff 200

HP BASIC Example 208

Procedure Overview 209

Contents

6 Authentication Tests

List of CDMA Authentication Tests 212

Initializing SSD to Zero 213

Measurement Overview 221

Updating SSD 222

Measurement Overview 229

Performing a Unique Challenge-Response 230

Measurement Overview 237

Contents

7 Short Message Service Tests

List of CDMA SMS Tests 240

Sending Short Messages on the Paging/Access Channels 241

Measurement Overview 249

Sending Short Messages on the Traffic Channels 250

Measurement Overview 258

Contents

8 Establishing HP-IB Communication

Setting Up HP-IB Control 260

Contents

9 264 Using the Analog Call Processing Subsystem

Description of the Analog Call Processing Subsystem 264

Operational Overview 265

Accessing the Analog Call Processing Subsystem Screens 267

Analog Call Processing Subsystem Screens 267

Using Manual (Front-Panel) Control 268

Connecting A Mobile Station 268

Mobile Station Audio Out Impedance 270

Generalized Test Procedure 270

Description of the Call Processing Subsystem's Remote User Interface 275

Operational Overview 276

Using Remote (HP-IB) Control 277

Accessing the Call Processing Subsystem Screens 277

Command Syntax 278

Conditioning the Test Set for Call Processing 279

Analog Call Processing Subsystem HP-IB Error Messages 280

Reading An Analog Call Processing Subsystem HP-IB Error Messages 280

Call Processing Status Register Group 281

Using the Call Processing Status Register Group To Control Program Flow 281

When To Query Data Messages Received From The Mobile Station 282

Using the CALL CONTROL Screen to Test Call Processing Functions 285

Conditioning the Test Set for Call Processing 285

Configure the Test Set 286

Turn On The Test Set's Control Channel 287

Register a Mobile Station 287

Page a Mobile Station 288

Handoff a Mobile Station to a New Voice Channel 289

Release A Mobile Station 289

Change the Transmit Power Level of a Mobile Station 290

Originate a Call from a Mobile Station 290

Send an Alert Order to a Mobile Station 291

Contents

Using the CALL CONTROL Screen to test AMPS Authentication 292

- Condition the Test Set for Call Processing 292
- Configure the Test Set 293
- Turn on the Test Set's Control Channel 294
- Initialize Call Processing with Authentication 294
- Page a Mobile Station with Authentication 296
- Originate a Call with Authentication 296
- Perform an SSD Update 297
- Perform a Unique Challenge 299

Using the CALL DATA Screen 301

- To View the Decoded Reverse Channel Words from a Mobile Station Page 302
- To View the Decoded Reverse Channel Words From a Mobile Station Handoff 304
- To View the Decoded Reverse Channel Words from a Mobile Station Release 305
- To View the Decoded Reverse Channel Words from an Order to Change the Transmit Power Level of a Mobile Station 306
- To View The Reverse Channel Words From a Mobile Station Origination 307

Using the CALL BIT Screen 308

- Selecting The Message Content Generation Method 308
- System Operation When Data Spec Field Set to Std 309
- System Operation When Data Spec Field Set to Bits 310
- Changing the Content of a Message Field 311
- Typical Example 311

Using the ANALOG MEAS Screen 313

- To Make an RF Sensitivity Measurement 313
- To Make an FM Hum and Noise Measurement 314

Contents

10 Controlling Program Flow

Using Service Request (SRQ) Interrupts 318

Controlling Program Flow Procedure 319

Examples Used in this Procedure 319

Example BASIC Program to Set Up and Service an SRQ Interrupt 328

11 Protocol Logging

Hardware and Software Requirements 335

Hardware Requirements 335

Software Requirements 336

Connecting the Test Set to the Computer 337

Setting Up the Communications Package 339

General Setup Parameters 339

Installing PROCOMM PLUS 339

Reconfiguring PROCOMM PLUS 340

Logging Protocol Messages 342

Capturing a Log to a File on the Computer 344

Control Commands for Protocol Logging 345

Logging Port 1 Commands 345

Logging Port 2 Commands 348

Contents

Index 351

Contents

Calibrating the Test Set

Calibration Procedures

The list below shows all of the calibration procedures that must be performed periodically when testing CDMA mobile stations with the Test Set, including Test Sets configured with an HP 83236B PCS Interface.

"Calibrating CDMA Channel Levels" on page 26

"Calibrating Channel Power Measurements" on page 29.

"Calibrating RF Generator Levels" on page 35

"Zeroing Average Power Measurements" on page 36.

"Correcting for RF Path Loss" on page 41.

"Determining RF Path Loss" on page 44.

Guidelines:

"Recommended Calibration Procedures:" on page 25 provides a checklist of calibration procedures for various events that could affect the performance of the Test Set.

Guidelines include:

- After **"Calibrating CDMA Channel Levels" on page 26** (also known as "PCB CAL") is performed, you must then perform **"Calibrating RF Generator Levels" on page 35** and **"Calibrating Channel Power Measurements" on page 29**.
- It is *highly* recommended that **"Correcting for RF Path Loss" on page 41** be performed before using the Test Set to make measurements. This procedure eliminates the need for adding level offsets to your test code, and extends the Test Set's operating range with some mobile stations.
- A 30-minute warm-up period is recommended to allow the Test Set to reach a stable operating temperature.

Recommended Calibration Procedures:

	"Calibrating CDMA Channel Levels" on page 26 (PCB CAL)	"Calibrating Channel Power Measurements" on page 29	"Calibrating RF Generator Levels" on page 35	"Zeroing Average Power Measurements" on page 36
When Test Set is being used for the first time (allow 30-minute warmup period).	✓	✓	✓	✓
After extended power off cycle (allow 30-minute warmup period).		✓	✓	
After firmware is upgraded	✓	✓	✓	
When the "Uncal" light is flashing			✓	
Before making an Average Power measurement				✓
If the RF connections to the PCS interface are adjusted.		✓	✓	
If the ambient temperature changes more than 5 degrees C since latest calibration	✓	✓	✓	
Ram Initialization	✓	✓	✓	✓
Every month	✓			

Calibrating CDMA Channel Levels

Approximate time: 8 minutes

CDMA channel levels should be calibrated whenever any of the following events occur:

- After a 30-minute warm-up period
- After firmware is upgraded
- If a 5° C change in ambient temperature occurs

The Test Set optimizes the level accuracy of CDMA code channels and the AWGN (Additive White Gaussian Noise) generator by measuring the analog I/Q signals on an internal DSP-based voltmeter. Level correction factors are generated by a ROM-based program named PCB_CAL and are applied to gain control DACs, which control the fine level adjustment in the amplitude scaling path.

Calibrated channel power provides accurate values for E_b/N_t , the ratio between Traffic channel power and AWGN. It is critical that these levels remain accurate. A level accuracy error of 0.8 dB could alter FER from 0.5% to 5%.

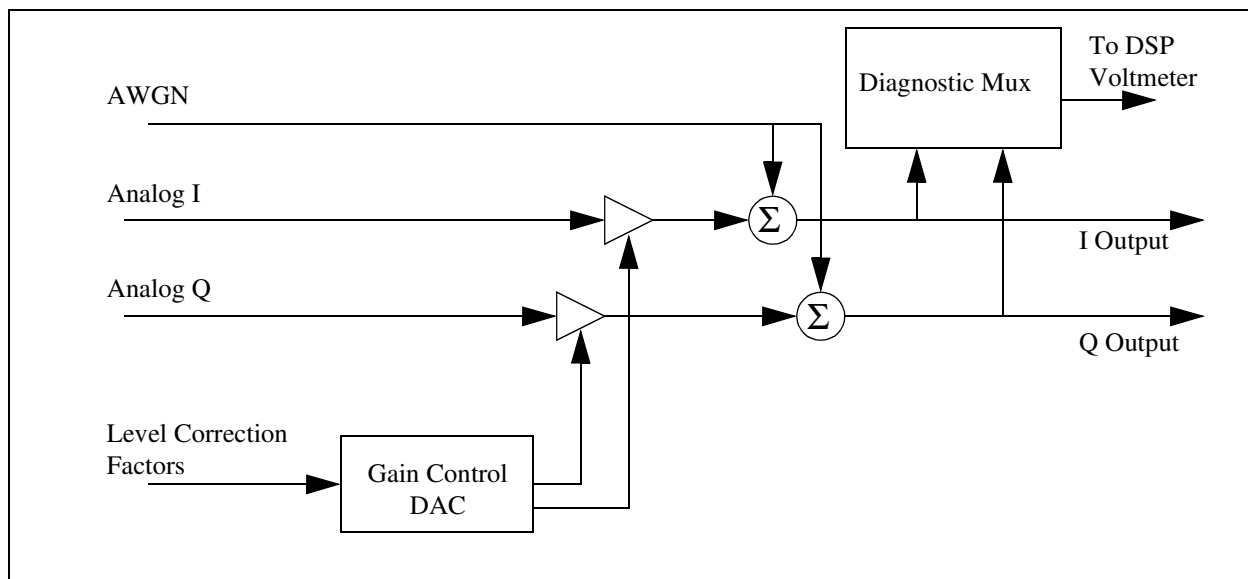

1. Load the PCB_CAL procedure.

Manual Operation:

1. Press the TESTS key.
2. Select ROM from the list of choices for the Select Procedure Location field.
3. Select PCB_CAL from the list of choices for the Select Procedure Filename field.

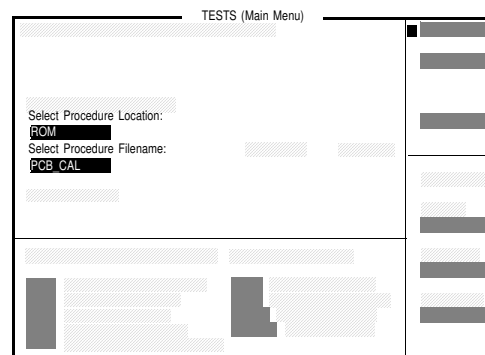

The TESTS (Main Menu) screen provides access to the Test Set's internal IBASIC controller. You can load, run, and customize procedures on this screen.

HP-IB Syntax

- "DISP TEST" ! displays the TESTS (Main Menu) screen.
- "TEST:PROC:LOC 'ROM'" ! selects ROM as the test procedure location.
- "TEST:PROC:NAME 'PCB_CAL'" selects the file named "PCB_CAL"

2. Run the PCB_CAL Procedure.

Manual Operation:

1. Position the cursor next to the Run Test field.
2. Press the knob.
3. Follow instructions on the display. (You will be instructed to remove all front-panel cables).
4. When the PCB_CAL procedure has completed, cycle power.

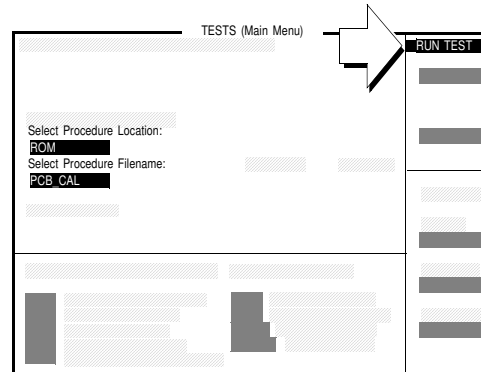

At the beginning of the procedure, the Test Set will beep and the message "Direct latch write occurred. Cycle power when done servicing" will appear. This is normal.

The PCB_CAL procedure will run for about 8 minutes. During this time the display will show cal factors for I and Q channels on the screen. When the calibration procedure has completed, the message "Cycle instrument power to restore test set to normal operating conditions" will be displayed at the top of the screen. At this point you should cycle power.

HP-IB Syntax

"TEST:PROC:RUN"

Calibrating Channel Power Measurements

Approximate time: 2 minutes

Channel power measurements should be calibrated whenever any of the following events occur:

- After a 30-minute warm-up period
- After firmware is upgraded
- When the "Uncal" annunciator is flashing
- If the RF connections to the PCS Interface are adjusted
- If the ambient temperature drifts more than 5 deg C after a 30-minute warm-up period

Channel Power measurements will be calibrated for the combined frequency bands included in the RF Chan Std (RF Channel Standard) and Alt Chn Std (Alternate Channel Standard) field selections.

Average Power measurements are zeroed as part of the Channel Power calibration process.

1. Connect the Test Set's generator to the Test Set's analyzer.

Manual Operation:

1. Connect cable(s) as shown.

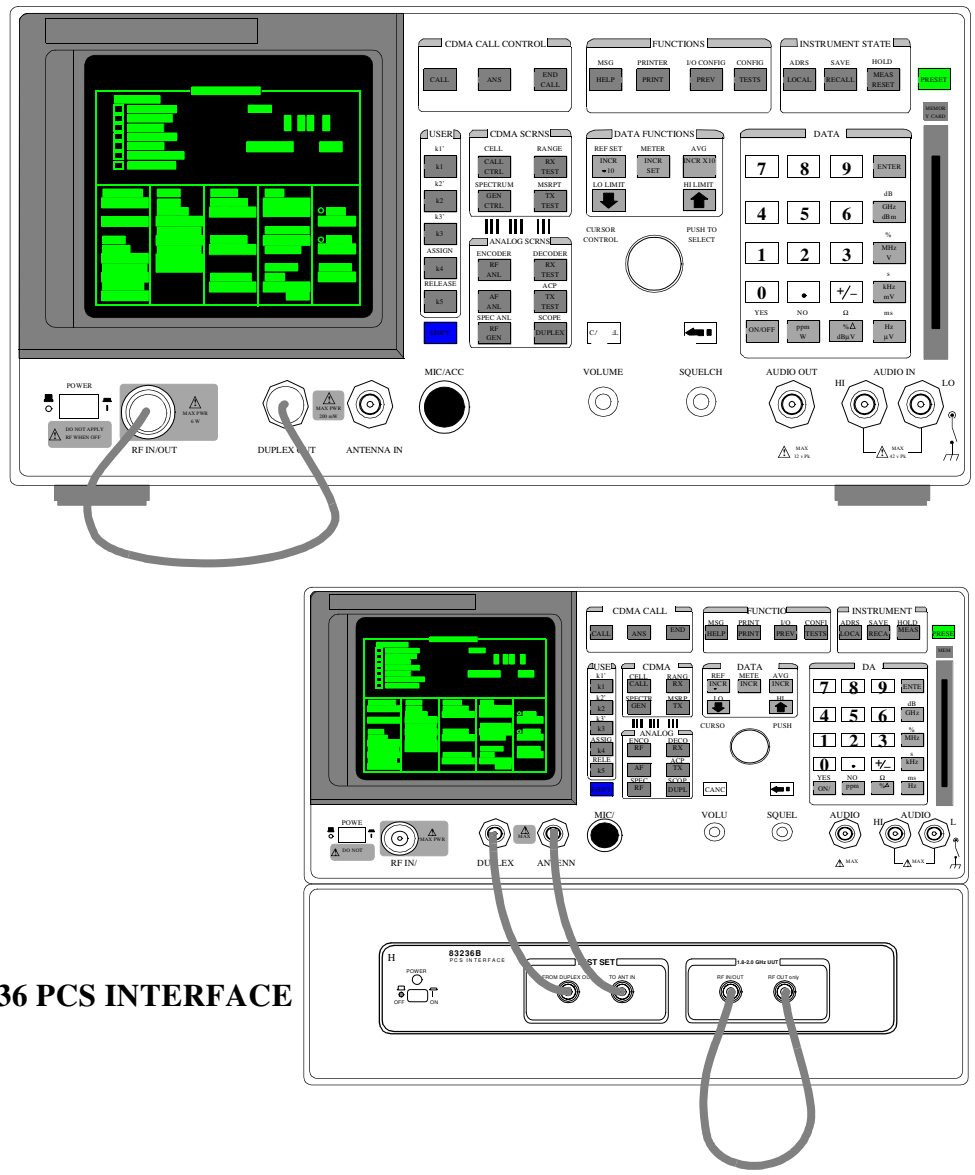

HP 83236 PCS INTERFACE

2. Enter an alternate channel standard. (Optional)

Manual Operation:

1. Press and release the SHIFT key and then press the TESTS key to display the CONFIGURE screen.
2. Position the cursor in front of Alt Chn Std field. Press the knob and select a channel standard from the list of choices.

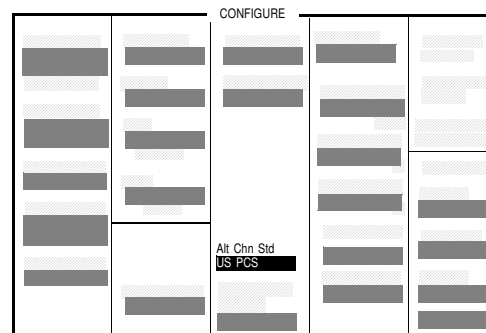

Channel Power Calibration will be performed over the frequency bands included in the RF Chan Std and the Alt Chn Std field selections. Adding an alternate channel standard will increase the time required for the Test Set to perform Channel Power Calibration.

3. Select the Channel Power measurement.

Manual Operation:

1. Position the cursor next to the field that displays Avg Power or Chan Power. This field is found on the CDMA CALL CONTROL, CDMA CELLULAR MOBILE TRANSMITTER TEST, and CDMA TRANSMITTER POWER RANGE TEST screens.
2. Make sure Chan Power is selected:
 - a. Press the knob to display the Choices menu.
 - b. Select Chan Power from the list of choices.

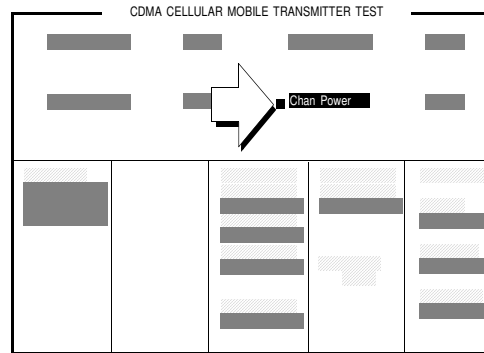

HP-IB Syntax

"CDMA:TX:POW:MEAS 'Chan Power'" selects Channel Power measurements.

4. Calibrate the Channel Power measurement.

Manual Operation:

1. Position the cursor next to the Power Meas field.
2. Press the knob.

The Test Set will display "Zeroing Average Power...", then "Calibrating Channel Power...." until calibration is complete.

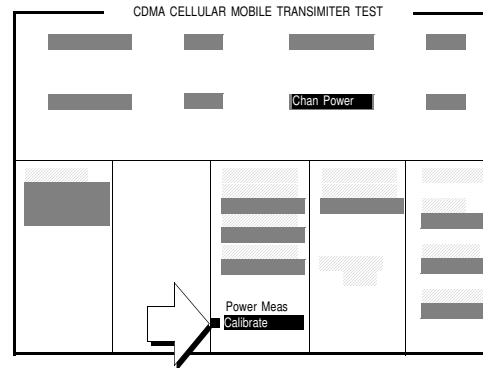

Calibration may take a minute or longer, depending on the RF Channel Std and Alt Chn Std field settings. If you are performing calibration using the HP-IB command below, be aware that the Test Set will accept (handshake) HP-IB commands during the calibration routine, but none of these "buffered" HP-IB command functions will be executed until channel power calibration is complete.

HP-IB Help

If your controlling application has an I/O timeout enabled, and a query such as "STAT:OPER:CAL:EVEN?" is sent after the channel power calibration has started, make sure that sufficient time is given for the Test Set to complete calibration and provide a query response in its output queue. Or, disable the timeout during channel power calibration.

Bit 0 in the Calibrating Status Event Register is Digital Power Zeroing (Power Meas "Zero" field). Bit 1 is Channel Power Calibration (Power Meas "Calibrate" field). With the Transition Filter Register in its default state, the Test Set will respond to the "STAT:OPER:CAL:EVEN?" query command with a decimal 3.

HP-IB Syntax

```
"MEAS:CDM:CHAN:CAL" !calibrates Channel Power measurements.  
"STAT:OPER:CAL:EVEN?" !queries the Calibrating Status Event Register"
```

Procedure Overview

1. **"Connect the Test Set's generator to the Test Set's analyzer." on page 30.**
RF IN/OUT and DUPLEX OUT connectors.

2. **"Enter an alternate channel standard. (Optional)" on page 31**

Screen: CONFIGURE

Enter choice in: **Alt Chn Std**

3. **"Select the Channel Power measurement." on page 32.**

Screen: CDMA CELLULAR MOBILE TRANSMITTER TEST

Enter choice in: **Chan Power**

4. **"Calibrate the Channel Power measurement." on page 33.**

Screen: CDMA CELLULAR MOBILE TRANSMITTER TEST

Calibrate select: **Power Meas**

Calibrating RF Generator Levels

This procedure applies only to Test Sets configured with an HP 83236B PCS Interface.

Approximate time: 15 seconds

RF generator levels should be calibrated whenever any of the following events occur:

- After a 30-minute warm-up period
- After firmware is upgraded
- If the RF connections to the PCS Interface are adjusted
- If the ambient temperature drifts more than 5 °C after a 30-minute warm-up period

The PCS Interface's internal compensation factors are used to compute the generator path attenuator values and the required signal level from the Test Set's DUPLEX OUT port. The RF IN/OUT path is automatically de-coupled within the PCS Interface during this procedure, so any RF link to a mobile station will be lost. This includes dropped calls and loss of CDMA or analog service from the Test Set.

1. Select the RF Gen Lvl field.

Manual Operation:

1. Press and release the SHIFT key and then press the TESTS key to display the CONFIGURE screen.
2. Position the cursor at the RF Gen Lvl field.
3. Start calibration by pressing the knob.

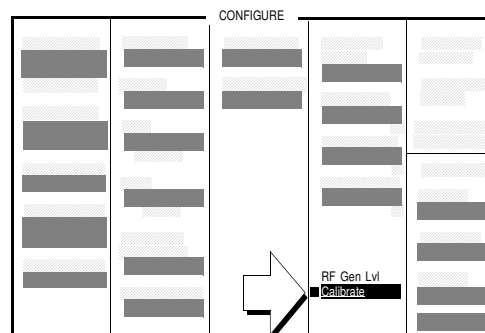

HP-IB Syntax

```
"CONF:RFSource:CALibrate" ! calibrates RF Gen levels
```

Zeroing Average Power Measurements

Approximate length of time: 2 seconds

Average Power measurements should be zeroed before each measurement or series of measurements.

NOTE:

*A misleading Average Power measurement may appear when low (or no) signal power is applied to the RF Input! When the RF generator's output port selection is **RF IN/OUT**, some of the signal energy from the Test Set's generator is detected by the Test Set's broadband average power meter. This condition does not affect typical CDMA measurements for two reasons: 1) During Average Power measurements CDMA generator levels are too low to introduce significant energy to the power detector. 2) When the generator level is high enough to introduce significant energy to the power detector, the mobile station's signal power should be within the range of Channel Power measurements. Channel power measurements are frequency-selective, and do not detect significant energy from the Test Set's generator, which is tuned 45 MHz away from the analyzer.*

1. Remove power from the RF IN/OUT connector.

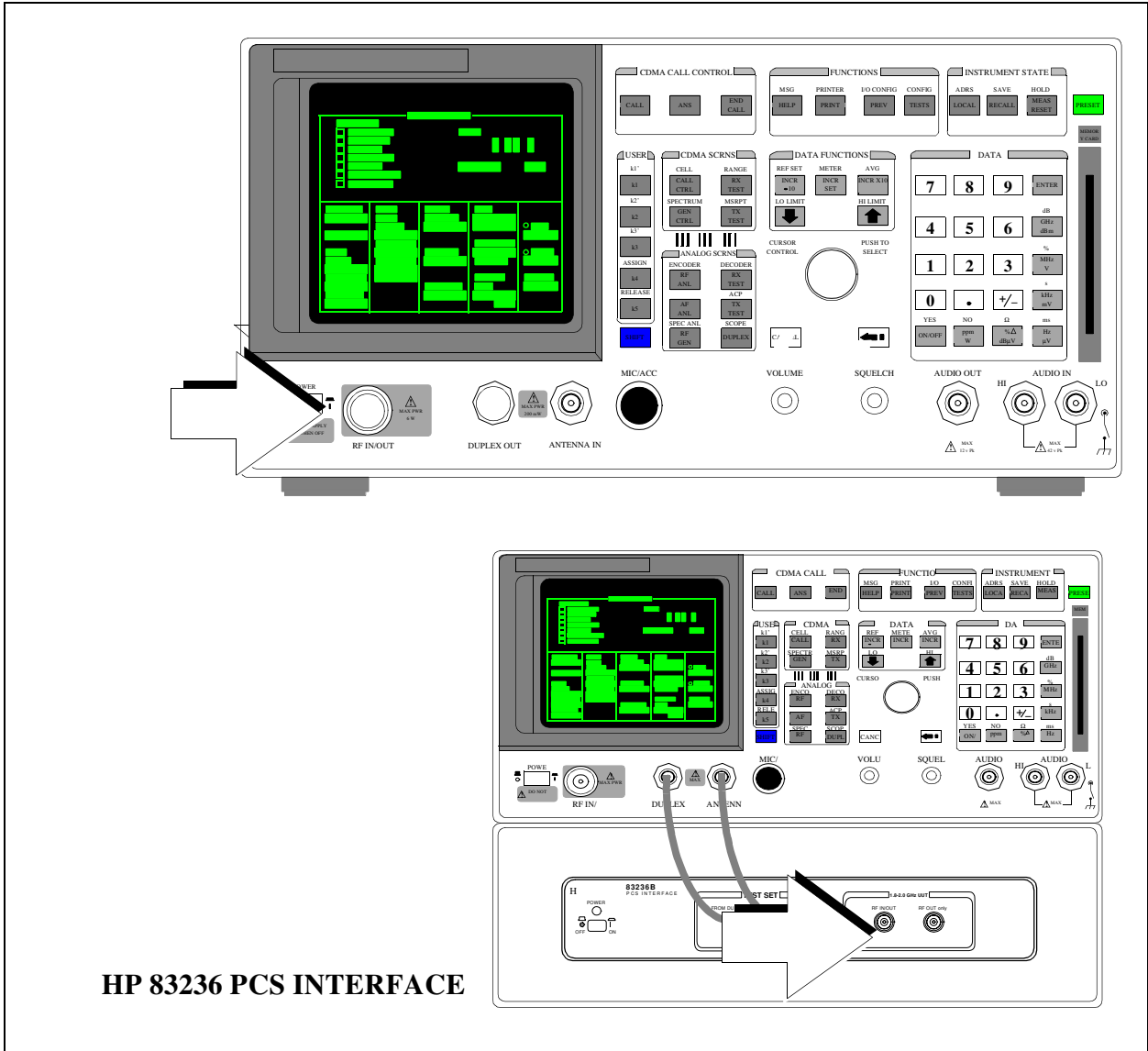

2. Lower the Test Set's output power if necessary.

Manual Operation:

1. Press the PRESET key, which will set RF Power to a level that will not degrade Average Power zeroing, or turn off all sources as follows:
2. Press the GEN CTRL key to display the CDMA GENERATOR CONTROL screen.
3. Turn off Sector A Power, Sector B Power, and AWGN (by pressing the ON/OFF key on the Test Set's front panel).

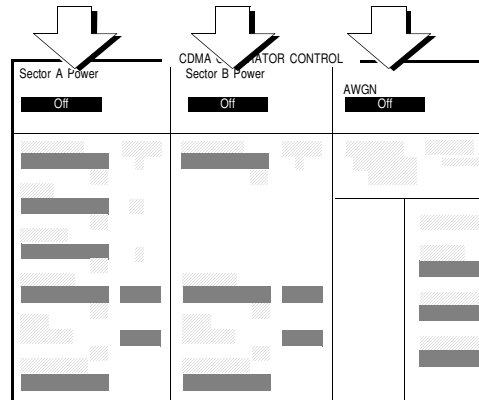

Turning off power from the CDMA generators will prevent power from cross-coupling internally to the RF IN/OUT path during Average Power measurement zeroing.

*Presetting the test Set (*RST HP-IB command) will turn off Sector B and AWGN, and will lower Sector A Power to a level that will not affect zeroing the Average Power measurement, making it unnecessary to turn Sector A Power off.*

HP-IB Syntax

- "CDMA:CELL:ASEC:STAT OFF" !turns off Sector A Power
- "CDMA:CELL:BSEC:STAT OFF" !turns off Sector B Power
- "CDMA:AWGN:STAT OFF" !turns off AWGN

3. Select the Average Power measurement.

Manual Operation:

1. Press the CDMA SCRNS - TX TEST key to display the CDMA CELLULAR MOBILE TRANSMITTER TEST screen.
2. Position the cursor next to the field as shown.
3. Press the knob to select the Choices menu.
4. Select Avg Power from the list.

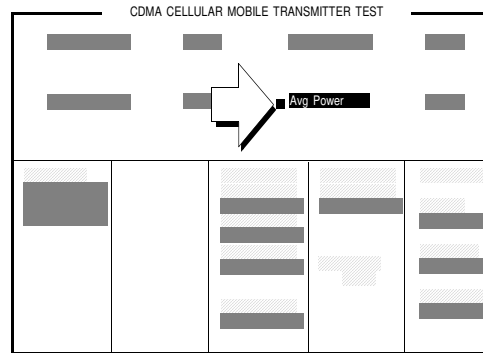

HP-IB Syntax

"CDMA:TX:POW:MEAS 'Avg Power'" selects Average Power measurements.

4. Zero the Average Power measurement.

Manual Operation:

1. Press the CDMA SCRNS - TX TEST key to display the CDMA CELLULAR MOBILE TRANSMITTER TEST screen.
2. Position the cursor next to the Zero field.
3. Press the knob.

Zeroing Average Power takes approximately two seconds.

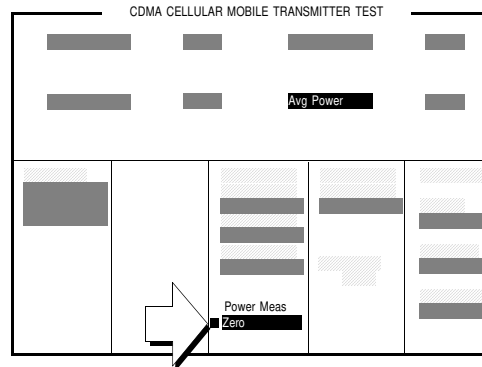

If RF power was not lowered as shown in step 2, the Test Set will display "Zero degraded. Reduce generator level for best results".

HP-IB Syntax

"MEAS:CDM:AVGP:ZERO" ! zeroes the average power meter.

Procedure Overview

1. **"Remove power from the RF IN/OUT connector." on page 37.**
RF IN/OUT connector.
2. **"Lower the Test Set's output power if necessary." on page 38.**
Screen: CDMA GENERATOR CONTROL
Turn off: **Sector A Power, Sector B Power, AWGN**
3. **"Select the Average Power measurement." on page 39.**
Screen: CDMA CELLULAR MOBILE TRANSMITTER TEST
Enter choice in: **Avg Power**
4. **"Zero the Average Power measurement." on page 40.**
Screen: CDMA CELLULAR MOBILE TRANSMITTER TEST
Observe: **Power Meas**

Correcting for RF Path Loss

Approximate time: N/A (this procedure is simply a field entry).

The settings you make in the following procedure must be re-entered after a power-cycle, instrument preset, or HP-IB reset ("*RST).

It is *highly* recommended that RF path loss is corrected for in the following manner.

NOTE:

The Test Set's attenuator auto-ranging algorithm, used for adjusting gain in the RF analyzer path, estimates the expected power level from the phone using the open loop power control formula. External path loss, entered in the procedure below, is used by the auto-ranging algorithm to ensure the analyzer is not overdriven or underdriven.

1. Enter the path loss from the Test Set to the MSUT.

If you do not know the path loss for your connecting hardware, see "[Determining RF Path Loss](#)" on page 44

Manual Operation:

1. Press and release the SHIFT key and then press the TESTS key to display the CONFIGURE screen.
2. Position the cursor in front of the appropriate field or fields below the RF Level Offset field and enter a value for RF path loss.

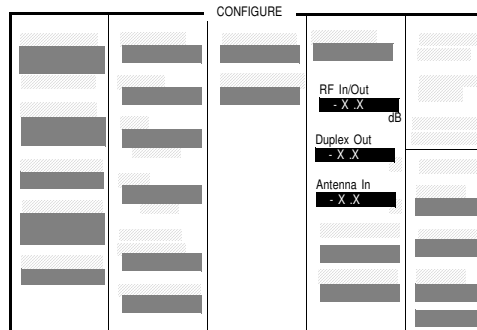

Example: If the measured loss is 2 dB, and you are using the RF In/Out port, enter -2 dB in the RF In/Out field. When the RF Level Offset is turned on, the displayed Average or Channel Power measurement will be increased by 2 dB and the displayed Sector A, Sector B, AWGN, and RF Power outputs will be decreased by 2 dB. No actual level changes occur as a result of turning on RF Level Offset.

2. Turn on RF Level Offset.

Manual Operation:

1. Position the cursor at the RF Level Offset field.
2. Select "On" to correct for RF path loss.

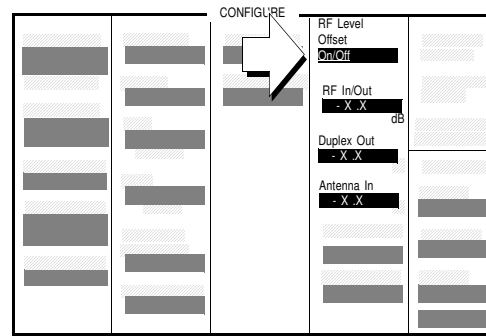

Determining RF Path Loss

The following procedure describes how to use the Test Set's signal generator and analyzer to determine path loss.

NOTE:

The Test Set's attenuator auto-ranging algorithm, used for adjusting gain in the RF analyzer path, estimates the expected power level from the phone using the open loop power control formula. External path loss, entered in the procedure below, is applied to the auto-ranging algorithm to ensure the analyzer is not overdriven or underdriven.

Procedure Prerequisites

Provide a reference cable, cable and hardware in RF path to MSUT, and adapters

You must provide a reference cable and the cable adapters necessary to mate the reference cable and the hardware that will be used in the path from the Test Set to the MSUT. Choose a reference cable with as little loss as possible.

Zero the Average Power measurement

Refer to "[Zeroing Average Power Measurements](#)" on page 36 if necessary, and then return to this procedure.

1. Connect a reference cable(s).

Manual Operation:

1. Connect cable(s) as shown.

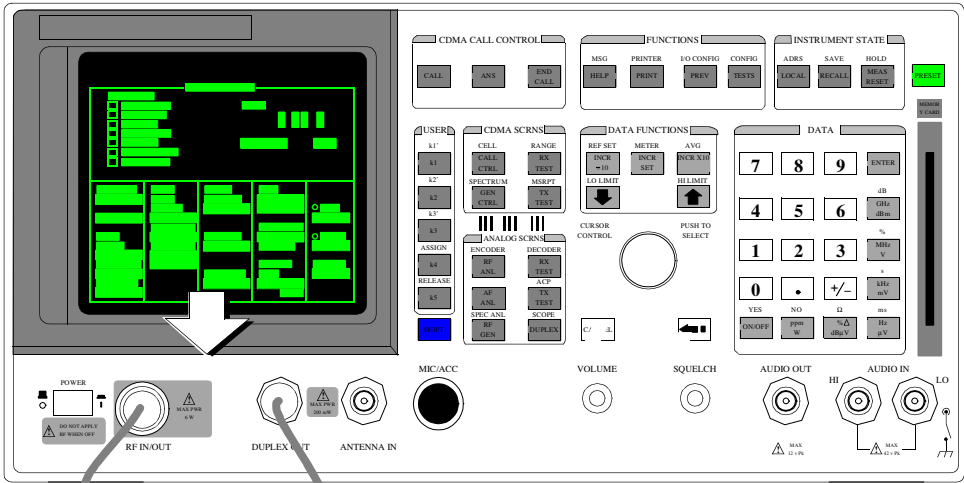

Low-loss reference cable

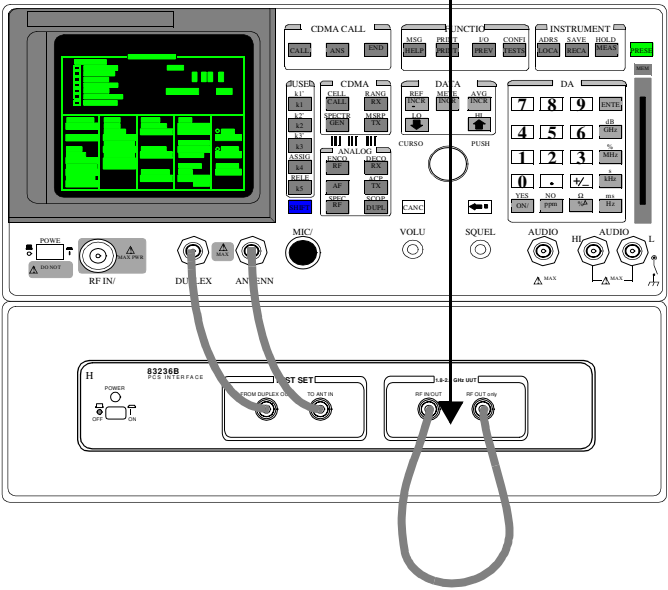

HP 83236 PCS INTERFACE

2. Configure the Test Set for RF loopback.

Manual Operation:

1. Press and release the SHIFT key and then press the TESTS key to display the CONFIGURE screen.
2. Position the cursor at the Output Port field.
3. Select Dupl (if no PCS Interface is configured) or only (if a PCS Interface is configured) by pressing the knob to toggle the underlined selection.

Skip steps 4 and 5 if a PCS Interface is configured

4. Position the cursor at the Input Port field.
5. Select RF In if it isn't already selected.

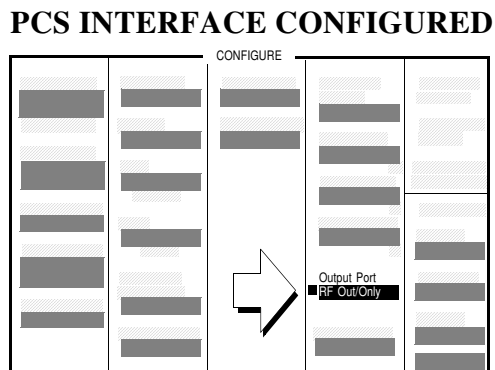
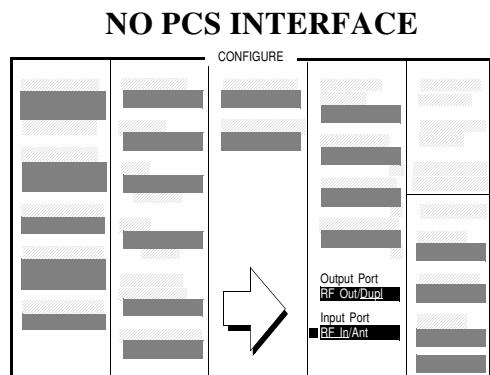

3. Determine a reference for the path loss measurement.

Manual Operation:

1. Press the CDMA SCRNS - TX TEST key to display the CDMA CELLULAR MOBILE TRANSMITTER TEST screen.
2. Position the cursor at the Sector A Power field.
3. Set the value to -11.0 dBm/BW with the DATA keys.
4. Position the cursor at the units-of-measure field and press the knob.
5. Press and release the SHIFT key, then press the INCR ÷ 10 key to set a 0 dBm reference.

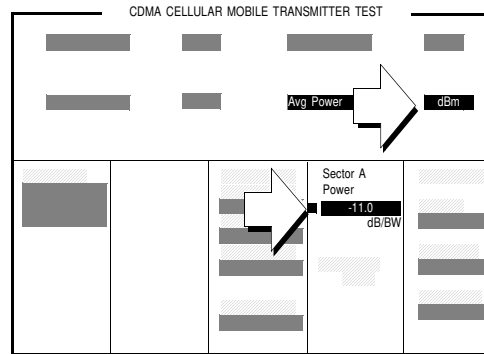

4. Connect the cable and hardware being measured for path loss.

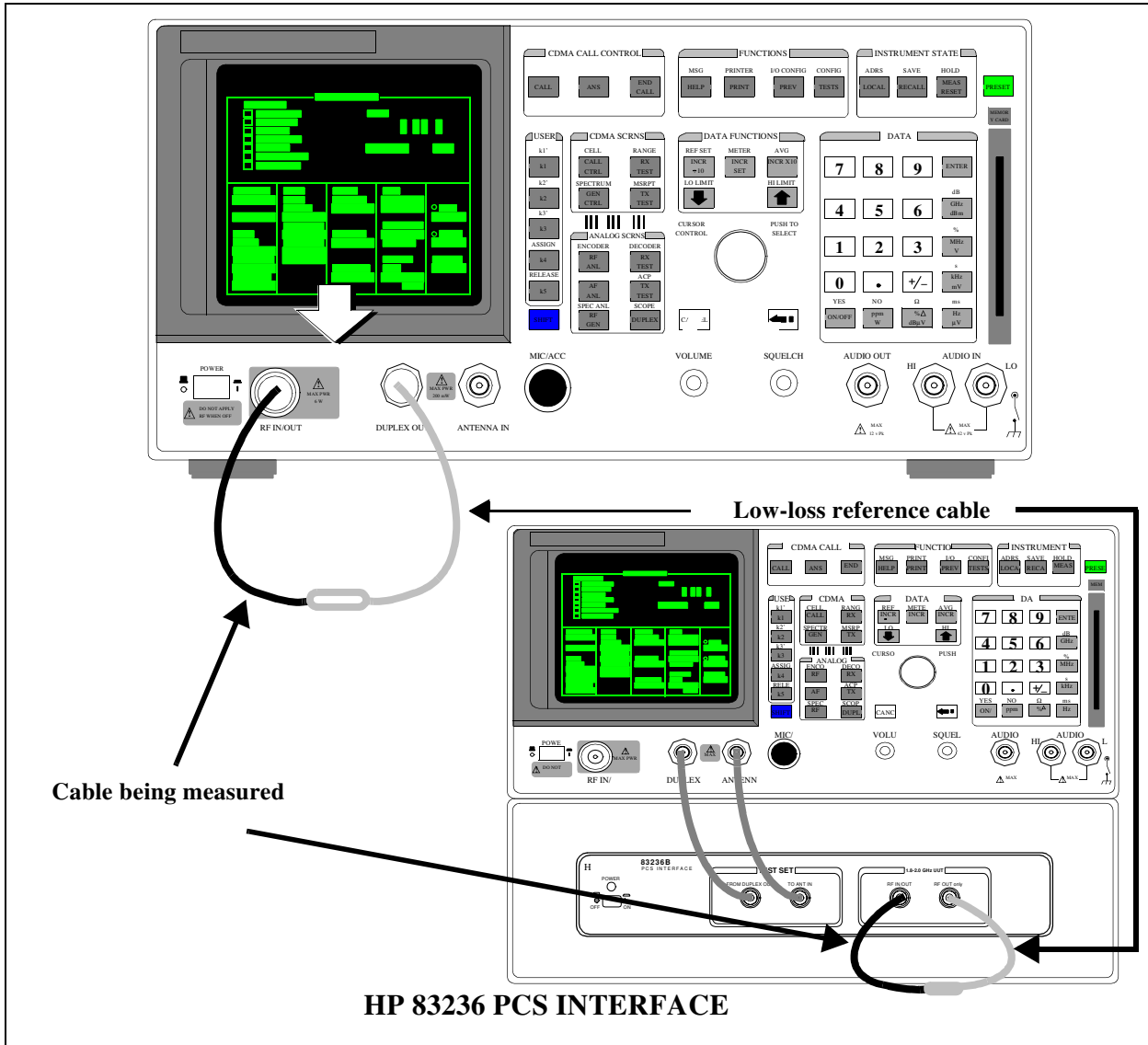

5. Determine the path loss.

This is the measured RF path loss that should be entered in the Test Set's Configure screen. See "Correcting for RF Path Loss" on page 41

Observe the average power measurement reading.

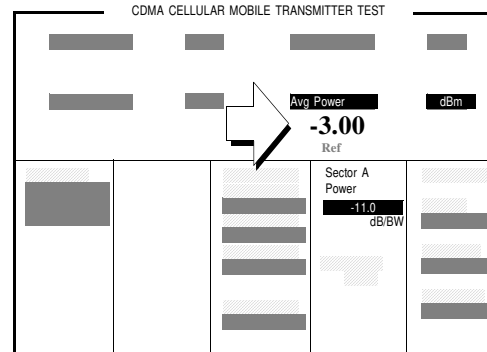

6. Re-configure the Test Set.

Manual Operation:

1. Press the PRESET key

Procedure Overview

1. **"Connect a reference cable(s)." on page 45.**
2. **"Configure the Test Set for RF loopback." on page 46.**
 Screen: CONFIGURE
3. **"Determine a reference for the path loss measurement." on page 47.**
 Screen: TRANSMITTER TEST
4. **"Connect the cable and hardware being measured for path loss." on page 48.**
5. **"Determine the path loss." on page 49.**
 Screen: TRANSMITTER TEST
6. **"Re-configure the Test Set." on page 50.**

Setting Up a Call

Setting up a Call

1. Preset the Test Set.

Manual Operation:

1. Turn on power to the Test Set and PCS Interface, if installed.
2. Wait for the Test Set to complete its power-up routine.
3. Press the PRESET key (in case the Test Set does not power up to factory default settings)

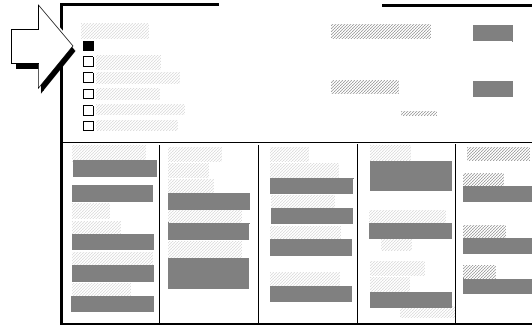

Pressing the PRESET key will configure the Test Set using factory default settings, and display the CDMA CALL CONTROL screen.

HP-IB Syntax:

"*RST" !configures the Test Set using factory default settings, and displays the CDMA CALL CONTROL screen.

2. Turn on PCS mode if necessary (Optional).

This step does not need to be performed if the Test Set was configured for PCS mode when last powered down. This step is only applicable to Test Sets with the HP 83236 PCS Interface and firmware later than A.05.00. The PCS Interface must be installed according to instructions found in the HP 83236B PCS Interface Operating Manual.

Manual Operation:

1. Press then release the SHIFT key then press the TESTS key to display the CONFIGURE screen.
2. Position the cursor at the PCS Mode field.
3. Press the knob to underline "On".
4. Cycle power to the Test Set to initialize communication between the Test Set and PCS Interface.
5. Preset the Test Set.

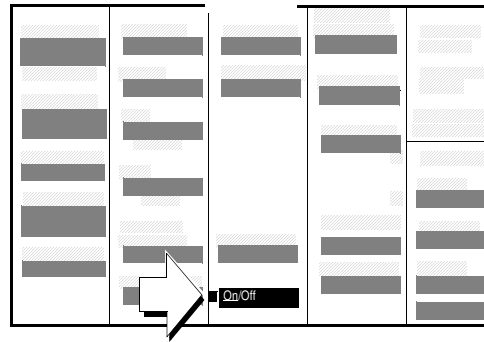

The PCS Interface extends the measurement capability of the HP 8924C to include the PCS frequency range.

The Test Set, when installed with firmware revision A.05.00 or higher, controls the PCS Interface via the rear-panel serial AUX CONTROL interface. A rocker switch on the PCS Interface rear panel labeled "HP-IB/Ser" must be in the "Ser" position for serial control.

When switching between the cellular and PCS frequency bands it is not necessary to turn PCS Mode "Off". This is because the PCS Interface provides conversion bypass paths (bypassing frequency up-conversion on the generator path and frequency down-conversion on the analyzer path) for operation in the cellular band.

HP-IB Syntax:

"CONF:PCSM 'On' " !turns PCS mode on

3. Correct for RF Path Loss.

Manual Operation:

1. Press then release the SHIFT key then press the TESTS key to display the CONFIGURE screen, if it is not already displayed.
2. Position the cursor at the RF In/Out field.*
3. Enter the RF path loss. For example, if the RF path loss is 2 dB, enter -2 in the RF In/Out field.
4. Position the cursor at the RF Level Offset field.
5. Select On to apply the offset.
6. Press the PREV key to return to the CDMA CALL CONTROL screen.

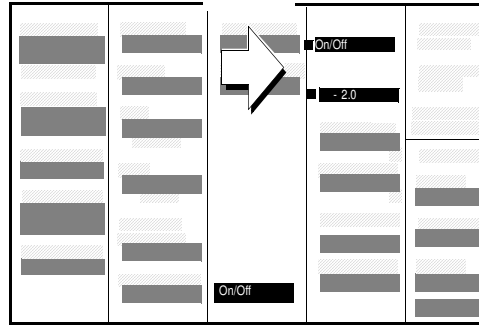

If you need a method for measuring path loss, refer to **"Determining RF Path Loss"** on page 44.

The Test Set corrects for path loss by changing displayed values. Example: If an RF path loss of -2 dB is entered in the RF In/Out field, and RF Level Offset is turned on, input power measurements will be 2 dB greater than the same measurement with RF Level Offset turned off.

Correcting for RF path loss allows the Test Set to achieve accurate gain settings in the RF analyzer path.

*If you are using an external duplexer, enter the path loss in the Duplex Out and Antenna In fields (displayed when the PCS Mode field is set to "Off").

HP-IB Syntax:

"CONF:OFL:RFIN -2;MODE 'ON'" !enters an RF path loss of 2 dB for the path to the RF In/Out connector, and turns the RF level offset On.

4. Enter the Protocol and RF Channel Standard of the mobile station under test (MSUT).

Manual Operation:

1. Press the CALL CTRL key to display the CONFIGURE screen.
2. Position the cursor at the Protocol field.
3. Press the knob to select the field.
4. Select the Protocol from the list of choices.
5. Position the cursor at the RF Chan Std field.
6. Press the knob to select the field.
6. Select an RF Channel Standard from the list of choices.

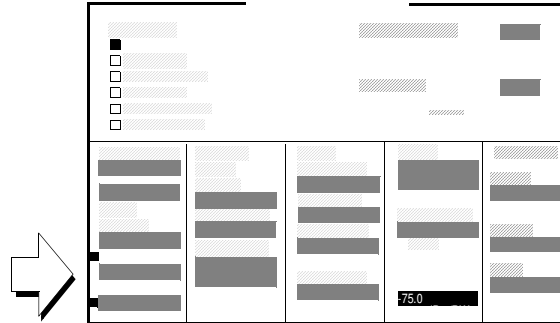

The list of RF Chan Std choices includes only those supported by the hardware configuration. Some RF channel standards require the HP 83236B with Option 007 (Wideband). Refer to the [RF Chan Std](#) field description in the HP 8924C Reference Guide.

HP-IB Syntax:

"CDMA:CELL:PROT 'IS-95A'" !selects the IS-95A protocol stack.

"CONF:RFCS 'MS AMPS'" !selects the AMPS RF channel standard.

5. Enter the MSUT's primary CDMA channel.

Manual Operation:

1. Position the cursor at the RF Channel field.
2. Enter the MSUT's Primary CDMA channel using the DATA keys.
3. Press the ENTER key or press the knob to enter the value.

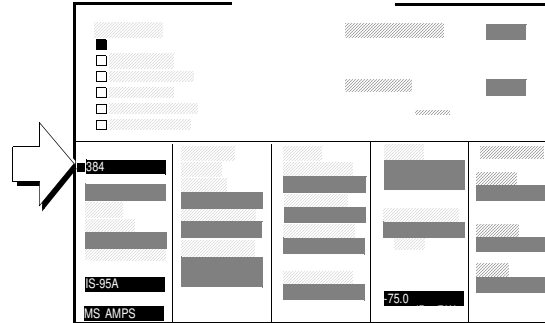

The MSUT's primary CDMA channel depends on its preferred serving system (System A or System B). Listed below are the primary CDMA channels specified in EIA/TIA IS-95 for System A and System B.
System A Primary CDMA Channel: 283.
System B Primary CDMA Channel: 384.

HP-IB Syntax:

```
"DISP CCNT;CDMA:RFCH 384" !selects channel 384.
```

6. Adjust Sector A Power. (Optional)

Manual Operation:

1. Position the cursor at the Sector A Power field.
2. Set the desired value using the DATA keys.
3. Press the ENTER key or press the knob to enter the value.

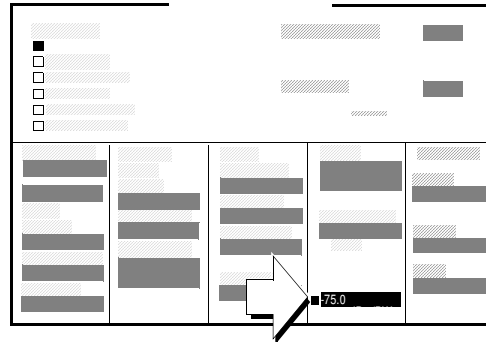

Sector A Power levels to the MSUT should be within the range of -25 dBm/BW to -105 dBm/BW. If the level of interference from other cellular signals is negligible, the preset value of -75 dBm/BW will be adequate for setting up a call.

HP-IB Help:

When entering Sector A Power values via the HP-IB, the default unit-of-measure is “dBm per 1.23 MHz bandwidth”, expressed as dBm/BW on the display.

HP-IB Syntax:

```
"DISP CCNT;CDMA:CELL:ASEC -75" !sets Sector A Power to -75 dBm/1.23 MHz bandwidth.
```

7. Connect the mobile-station-under-test (MSUT).

Manual Operation:

Connect the MSUT to the Test Set's RF IN/OUT connector.

Make sure all connections to the MSUT, including dc power, are made.

Some MSUT's do not have an RF connection. The MSUT manufacturer will usually make a fixture, such as a car adapter, that will provide an RF cable connection to the Test Set. The MSUT is then snapped into the fixture and an RF connection is made through an electromagnetic coupler near the MSUT antenna. When setting up a call with these type of MSUT's, the MSUT may need to be isolated from interfering signals.

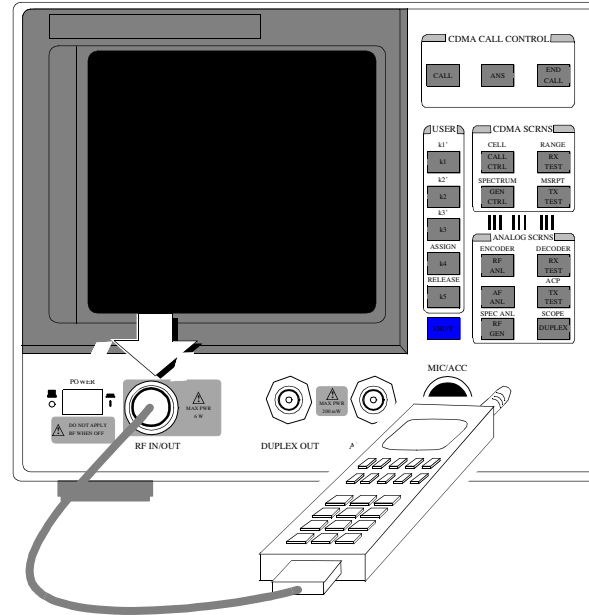

8. Turn on power to the MSUT and wait for the MSUT to find digital service.

Manual Operation:

Wait until the MSUT has found digital service (this should take no longer than about 30 seconds).

If the MSUT does not find service, refer to "[Checklist 1. MSUT did not find service](#)" on [page 68](#).

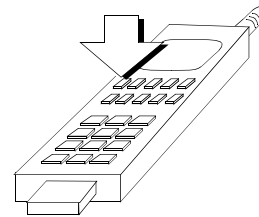

Most MSUT's have a NO SERVICE annunciator that will go out when the mobile station has found service. Other MSUT's use an LED that indicates when service has been found. If the MSUT is programmed to prefer analog service, and a strong signal from an analog base station is present, the MSUT may not find digital service. If this condition exists, re-program the phone or isolate it from the competing analog signal.

Caution: Do not exceed 6 W continuous power into the Test Set's RF IN/OUT connector with any transmitter.

9. Select the desired Service Option.

Manual Operation:

1. Position the cursor at the Traffic Data Mode field.
2. Press the knob to select the field.
3. Select a Service Option.

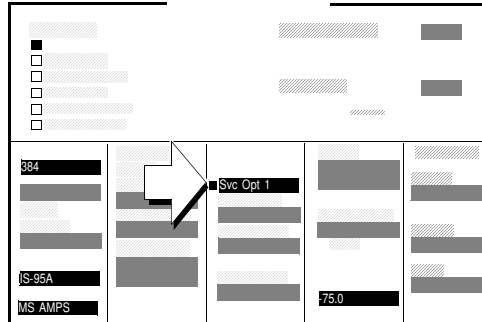

Service Option 1 and 9 select voice loopback (normal traffic) mode. When a Service Option 1 or 9 call is connected, the Test Set will echo voice information back to the MSUT with a settable delay.

Service Option 2 and 32768 select data loopback mode specified by IS-98 for MSUT receiver testing.

HP-IB Syntax:

```
"DISP CCNT;CDMA:CALL:TRAF:DATA:MODE 'SVC OPT 2' "  
!selects service option 2 (data loopback mode)
```

10. Register the MSUT (MSUT must be “roaming” and not in the process of power-up registration).

If you are going to make a call *from* the MSUT, or if you allow the MSUT to perform a power-up registration, you can skip this step and continue with "[MSUT-Originated Call](#)" on page 64.

IMPORTANT

If your MSUT is programmed to operate “Home Only,” or if the Pwr Up Reg field on the CDMA CELL SITE CONFIGURATION screen is “On” and the mobile station has not registered yet, this registration procedure will likely fail (in this case the error message “Time-out occurred while attempting to register mobile...” will be displayed). If you know your MSUT’s preferred system is “Home Only,” either re-program the MSUT to allow roaming, or skip Step 10 and continue with "[MSUT-Originated Call](#)" on page 64 or re-program the MSUT to allow roaming.

Manual Operation:

1. Position the cursor at the **Register** field.
Optional: Select *Clr All* in the MS Database list of choices to remove any data from previous registrations.
2. Push the knob to select the **Register** field. The **Registering** annunciator will light.
3. Watch for the **Registering** annunciator to go out. If the registration attempt times out, refer to "[Checklist 2. Registration failed](#)" on page 70.

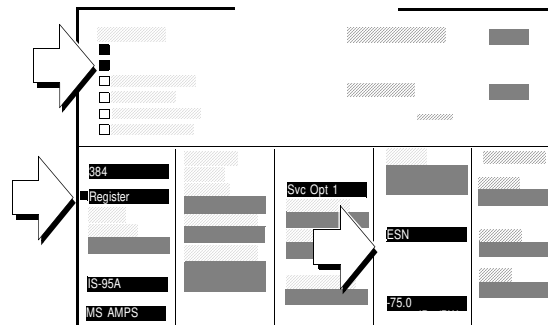

Registration provides the Test Set with the MSUT’s identification, thereby enabling the Test Set to correctly address pages. (An alternative method for providing the Test Set with the MSUT’s identification is to enter Phone Number, MIN, or IMSI directly into the MS ID field on the CDMA Call Control screen. This alternative method could result in significant time savings in a production test environment but the numbers you enter must precisely match the internal NAM (Numeric Assignment Module) settings in the MSUT and the MSUT must be non-slotted).

When the Register field is selected, values entered in the CDMA Cell Site Configuration screen’s Rgstr SID and Rgstr NID fields are sent to the MSUT in a message called the System Parameters message. This SID/NID pair causes the MSUT to perform a “zone-based” registration. The Rgstr SID and Rgstr NID fields are set by default to 12. These values do not need to be changed unless the MSUT is programmed to not recognize them as valid, or the MSUT recognizes them as its home SID/NID. If either of these conditions exist, change Rgstr SID and Rgstr NID to arbitrary values that are both valid for the MSUT and do not match the MSUT’s home SID/NID.

HP-IB Help: The Call Status Registering annunciator is assigned to bit 11 in the CDMA Status Register Group. The following program example polls the CDMA Status Event Register until bit 11, Mobile Station Registered, goes true.

HP-IB Syntax:

DISP CCNT;CDMA:MOB:REG !causes the mobile station to register.

HP BASIC Example

```
1 RE-SAVE "C:\HPBASIC\REG"
10 OUTPUT 714;"CDMA:MOB:DAT '*Clr All*'" !Clears MS Database values
20 OUTPUT 714;"CDMA:MOB:REG"!Begins the zone-based registration process
30 T=TIMEDATE
40 REPEAT
50 OUTPUT 714;"stat:cdma:even?" !Queries CDMA Status Event Register
60 ENTER 714;Reg
70 IF TIMEDATE-T>=25 THEN
80 PRINT "ERROR"
90 STOP
100 ELSE
110 WAIT .1 !Prevents HP-IB commands from dominating Test Set processes
120 END IF
130 UNTIL BIT(Reg,11)
140 END
```

11. Make a call.

The Test Set supports both **MSUT-terminated** (originated from the Test Set), or **MSUT-originated calls**. Both types of calls are described below.

MSUT-Terminated Call

Manual Operation:

1. Press the Test Set's CALL key. (The phone will not ring if you have selected a service option 2 or 9 call).
2. If the service option 1 or 32768 is selected, press the SEND key on the MSUT's keypad to connect the call.
3. Verify that the Connected annunciator is lit.

Optional: Speak into the phone to test voice quality if service option 1 or 3768 is selected.

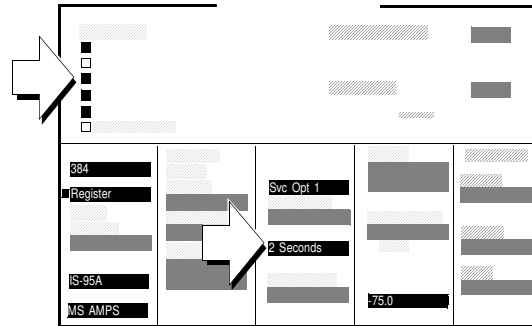

After the CALL key is pressed on the Test Set, the Page Sent annunciator will light to indicate that a paging message was sent to the MSUT. The Access Probe annunciator will then light to indicate that the mobile station transmitted an access probe sequence in an attempt to gain system access. The MSUT should ring if the Traffic Data Mode is set to service option 1 or 32768.

HP-IB Help:

The following CDMA Status Register Group bits monitor the call processing states:

- Page Sent (BCD 2)
- Access Probe (BCD 1)
- Alerting (BCD 16)
- Connected (BCD 8)

Condition registers are implemented for these bits, allowing HP-IB operation to mirror the way they work on the display.

HP-IB Syntax:

"CDMA:CALL:MAKE" !makes a call from the Test Set (mobile terminated).

MSUT-Originated Call

Manual Operation:

Enter any phone number on the MSUT's keypad and press the SEND key.

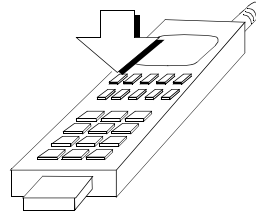

After Send is pressed on the MSUT, the Access Probe annunciator on the Test Set, will light to indicate that the mobile station sent an access probe sequence in an attempt to gain system access.

The Test Set's Connected annunciator will light indicating that the MSUT is in the "Mobile Station Control on the Traffic Channel State."

If the Test Set's Answer Mode field is set to Manual, you must press the Test Set's ANS key to manually answer the phone.

HP-IB Help: Refer to "[MSUT-Terminated Call](#)" on page 63"

HP-IB Syntax:

"CDMA:CALL:ANSW" !answers a call from the MSUT.

(This command is only necessary when the Test Set's **Answer Mode** field is **Manual**).

HP-IB Example: The following [HP BASIC example](#) uses service requests to detect when the following call-processing events occur:

- Page Sent
- Alerting (not included as a front-panel display annunciator)
- Connected

See "[CDMA Status Register Group](#)" in the Status Reporting chapter of the *HP 8924C User's Guide*.

```

10     Status_byte = SPOLL(714)      !clears the Status Byte Register
20     OUTPUT 714;"*CLS" !clears all event registers
30     CALL Cdma_register_enable 31   !calls subprogram to enable selected bits in
31     !the CDMA Status Register Group
40     CALL Operation_register_enable !calls subprogram to enable selected bit in
41     !the Operation Status Register Group.
50     ALL Status_register_enable     !calls subprogram to enable bit in
51     !the Status Byte Register.
60     ON INTR 7,15 CALL Interrupt     !specifies a program branch to Interrupt
61     !subprogram when an interrupt occurs.
70     ENABLE INTR 7;3                !enables the SRQ interrupt (Decimal 2 enables bit 1 of the
    !HP-IB interrupt enable register "SRQ Received").
80     PRINT "WHEN MOBILE STATION IS REGISTERED, PRESS CONTINUE"
90     PAUSE
100    OUTPUT 714;"DISP CCNT;CDMA:CALL:MAKE"
110    LOOP
120    DISP "WAITING FOR A SERVICE REQUEST INTERRUPT"
130    END LOOP
140    END !End of program
150    SUB Cdma_register_enable
160    OUTPUT 714;"STATUS:CDMA:PTR 26;NTR 0"
161    !enables the CDMA Status Register Group positive
162    !transition register for the following bits:
163    !Page Sent (1), Alerting (4), and Connected (3)
170    OUTPUT 714;"STATUS:CDMA:ENAB 26"
171    !enables the CDMA Status Register Group event
171    !register to send a summary message
172    !bit for the selected events.
180    SUBEND
190    SUB Operation_register_enable
200    OUTPUT 714;"STAT:OPER:PTR 256;NTR 0;ENAB 256"
201    !enables the Operation Status Register Group positive transition register for
    !the CDMA Status Register Group summary message bit (8), and enables the event
    register to send a summary message bit for the selected events.
210    SUBEND
220    SUB Status_register_enable
240    OUTPUT 714;"*SRE 128"!enables bit 7 of the Status Register, the summary
241    !message bit from the Operation Status Register Group.
260    SUBEND
280    SUB Interrupt
300    Status_byte=SPOLL(714)
310    OUTPUT 714;"STAT:CDMA:EVEN?"
311    !queries the CDMA Status Register Group event register
320    ENTER 714;Event_reg
330    SELECT
340    CASE=2
360    PRINT "PAGE SENT"
380    CASE=16
400    PRINT "ALERTING...ANSWER PHONE"
410    CASE=8
420    PRINT "CALL IS CONNECTED"
440    STOP
460    END SELECT
480    OUTPUT 714;STAT:OPER:EVEN?
481    !query the Operation Status Register Group event register to clear bit 8,
482    !the CDMA Status Register Group summary message bit.
500    ENTER 714;Oper_event !terminates query
510    ENABLE INTR 7        !re-enables the SRQ interrupt
520    SUBEND

```

Procedure Overview

1. **"Preset the Test Set." on page 52.**
Screen: CDMA CALL CONTROL
Observe: **Transmitting**
2. **"Turn on PCS mode if necessary (Optional)." on page 53.**
Screen: CONFIGURE
Enter value in: **PCS Mode**
Select: **On**
3. **"Correct for RF Path Loss." on page 54.**
Screen: CONFIGURE
Enter value in: **RF In/Out, Duplex Out, or Antenna In**
Select: **RF Level Offset On**
4. **"Enter the Protocol and RF Channel Standard of the mobile station under test (MSUT)." on page 55.**
Screen: CDMA CALL CONTROL
Enter choices in: **Protocol, RF Chan Std**
5. **"Enter the MSUT's primary CDMA channel." on page 56.**
Screen: CDMA CALL CONTROL
Enter value in: **RF Channel**
6. **"Adjust Sector A Power. (Optional)" on page 57.**
Screen: CDMA CALL CONTROL
Observe: **Sector A Power**
7. **"Connect the mobile-station-under-test (MSUT)." on page 58.**
RF IN/OUT connector
8. **"Turn on power to the MSUT and wait for the MSUT to find digital service." on page 59.**
Wait for MSUT to find service.
9. **"Select the desired Service Option." on page 60.**
Screen: CDMA CALL CONTROL
Enter choice in: **Traffic Data Mode**

10. "Register the MSUT (MSUT must be "roaming" and not in the process of power-up registration)." on page 61.

Screen: CDMA CALL CONTROL
Select: **Register**

11. "Make a call." on page 63.

"MSUT-Terminated Call" on page 63

Press: CALL key
Screen: CDMA CALL CONTROL
Observe: **Page Sent, Access Probe, Connected** annunciators

"MSUT-Originated Call" on page 64

Enter Phone Number: MSUT
Send the call: MSUT
Screen: CDMA CALL CONTROL
Observe: **Page Sent, Access Probe, Connected** annunciators

Problem Solving

Checklist 1. MSUT did not find service

If the MSUT won't find service, refer to this checklist. If the MSUT has found service but won't register, refer to "[Checklist 2. Registration failed](#)" on page 70.

- Is the RF cable connected?*
- Is the RF Channel number correct? (Set the RF Channel on the CDMA Call Control screen.) Refer to [table 1](#) and [table 2](#).*
- Is Sector A Power adequate? If interference from other cellular band signals is present, Sector A Power may need to be set to a level greater than the instrument preset value of -75 dBm/BW. (Set Sector A Power on the CDMA Call Control screen.) Example: If the MSUT is finding analog service, adjust Sector A Power to -25 dBm/BW, then cycle power on the MSUT. Isolating the MSUT may be necessary.*
- Is the AWGN generator (CDMA Gen Control screen) off?*
- Is the MSUT programmed "Home Only"? If so, set the SID on the CDMA Cell Site Configuration screen, then cycle power on the phone. If you don't know the correct SID, set Esc Mode "On" (on the CDMA Cell Site Configuration screen).*

Refer to [table 1](#). for SID (System ID) and RF Channel requirements.

Table 1

SID and RF Channel Settings for Call Setup

If MSUT is programmed to...	the System ID field entry (on the Cell Configuration screen) must be...	The RF Channel field entry (on the Call Control screen) must be...
Prefer System A	Don't Care	set to the System A or System B Primary or Secondary channel.
Prefer System B	Don't Care	set to the System B or System A Primary or Secondary channel.
System A Only	Don't Care	set to the System A Primary or Secondary channel
System B Only	Don't Care	set to the System B Primary or Secondary channel

Table 1 SID and RF Channel Settings for Call Setup

If MSUT is programmed to...	the System ID field entry (on the Cell Configuration screen) must be...	The RF Channel field entry (on the Call Control screen) must be...
Home Only	Same as MSUT Home_SID	set to either System A or System B Primary Channels. Try both.

Table 2 CDMA Channel Numbers (from EIA/TIA IS-95)

System	Range (CDMA)	Primary Channels	Secondary Channels
A	1 to 311, 689 to 694	283 ^a	691 ^a
B	356 to 644, 739 to 777	384 ^a	777 ^a

- a. This channel number, although specified in the IS-95 standard as a primary or secondary channel, can be changed in the MSUT by re-programming the NAM. Trying these values *might* allow the MSUT to find service, but the only way to be certain of the correct channel numbers is to gain access to the NAM program menu in the MSUT.

Checklist 2. Registration failed

If the MSUT has found service but won't register, refer to this checklist.

- Is the MSUT programmed to "Home Only"? (To use the CDMA Call Control screen's Register field, the MSUT must be programmed to allow roaming.)*
- Are the entries in the Rgstr SID and Rgstr NID fields valid entries for the MSUT? (The Rgstr SID and Rgstr NID field entries, found on the CDMA Cell Site Configuration screen, must be recognized as a valid SID/NID pair by the MSUT).*
- Do the entries in the Rgstr SID and Rgstr NID fields match the MSUT's Home SID/NID? (The Rgstr SID and Rgstr NID fields, found on the CDMA Cell Site Configuration screen, must be different than the MSUT Home SID/NID).*
- Is the power supply providing adequate current? (Make sure the MSUT's power supply duplicates the voltage, impedance, and ampere hours of the manufacturers recommended power supply).*

NOTE:

If all attempts to register the MSUT using the CDMA Call Control screen's Register field fail, perform the procedure, "**MSUT-Originated Call**" on page 64. When the Call Status Connected annunciator is lit, the Test Set will acquire the MSUT's phone number and MIN without performing a registration.

CDMA Receiver Tests

List of CDMA Receiver Tests

"Measuring Demodulation of Forward Traffic Channel with AWGN" on page 73.

"Measuring Receiver Sensitivity and Dynamic Range" on page 87.

"Measuring Single Tone Desensitization" on page 99.

"Measuring Intermodulation Spurious Response Attenuation" on page 115.

"Measuring Demodulation of Non-Slotted Mode Paging Channel in AWGN" on page 128.

Measuring Demodulation of Forward Traffic Channel with AWGN

The Test Set performs "Demodulation of Forward Traffic Channel in Additive White Gaussian Noise" as described in TIA IS-98, "CDMA Receiver Minimum Standards."

During this test, FER is measured as the Test Set provides various data rates to the mobile-station-under-test (MSUT) with the Test Set's AWGN generator turned on.

Test Prerequisites

Determine Cable Path Loss

When using cables to connect the equipment, the path loss for the cable(s) should be determined. The Test Set can be used as a source to measure path loss.

Refer to "[Correcting for RF Path Loss](#)" on page 41 if necessary, and then return to this procedure.

NOTE:

The following procedure assumes that an instrument PRESET will be performed as part of setting up a call. This clears all settings from other tests that may affect the accuracy of this test, and allows the procedure to begin from a known instrument state.

1. Make a Service Option 2 or 9 call.

See "[Setting up a Call](#)" on [page 52](#) if you are not familiar with how this procedure is performed with the Test Set.

After setting up the call, return to this procedure.

2. Set the test parameter Traffic E_c/I_{or} .

Manual Operation:

1. Press the CDMA SCRNS - RX TEST key to display the CDMA CELLULAR MOBILE RECEIVER TEST screen.
2. Position the cursor at the Traffic field.
3. Set the Traffic E_c/I_{or} value with the DATA keys. Refer to the TIA IS-98 performance standards for test parameters.
4. Press the ENTER key or the knob to enter the value.

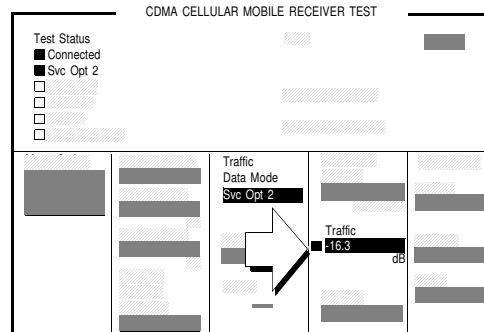

Sector A Pilot E_c/I_{or} has a factory preset value of -7 dB. If it is necessary to change this setting, access the CDMA GENERATOR CONTROL screen. The CDMA GENERATOR CONTROL screen also displays total RF Power.

Traffic E_c/I_{or} is defined as the ratio of the average transmit energy per PN chip for the Forward Traffic Channel to the total transmitted power spectral density. Values in this field are expressed in dB, relative to Sector A Power.

HP-IB Help

When the CDMA CELLULAR MOBILE RECEIVER TEST screen is accessed using an HP-IB command, continuous FER measurements are automatically triggered, and the **Testing** annunciator will be lit. To change trigger mode to single, send the HP-IB command "TRIG:MODE:RETR SING".

HP-IB Syntax

"DISP CRXT" !accesses the CDMA CELLULAR MOBILE RECEIVER TEST screen.

"CDMA:CELL:ASEC:TRAF -16.3" !sets Sector A Traffic E_c/I_{or} to -16.3 dB.

3. Set the test parameter AWGN (I_{oc}).

<p>Manual Operation:</p> <ol style="list-style-type: none"> 1. Position the cursor at the AWGN field. 2. Press the ON/OFF key. 3. Adjust the value if necessary. 	
<p><i>AWGN (I_{oc}) determines the signal-to-noise ratio \hat{I}_{or}/I_{oc}. The Sector A Power field sets \hat{I}_{or}.</i></p> <p><i>To obtain a ratio of -1, set AWGN 1 dB higher in power than Sector A Power.</i></p> <p><i>I_{oc} is defined as the power spectral density of a band-limited white noise source (simulating interference from other cells) as measured at the mobile station's antenna connector.</i></p>	

HP-IB Syntax

"CDMA:AWGN:STAT ON" !turns the Test Set's AWGN generator on.

"CDMA:AWGN -74" !sets AWGN to -74 dBm/BW.

4. Verify correct E_b/N_t reading.

Manual Operation:

Refer to the applicable standard for correct E_b/N_t values.

E_b/N_t is not a user-settable field.

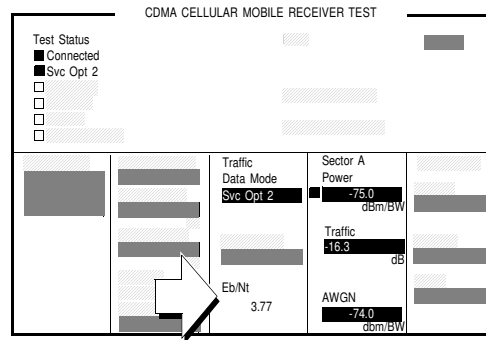

E_b/N_t is calculated from Sector A Power, AWGN, and the Data Rate. Refer to TIA IS-98 for values.

The resolution of E_b/N_t as displayed on the Test Set is in hundredths of a dB. TIA IS-98 expresses this value in tenths. Example: If the TIA IS-98 standard specifies 3.8, the Test Set may display 3.77.

HP-IB Syntax

"CDMA:STN?" !queries the E_b/N_t field.

5. Set the FER specification.

Manual Operation:

1. Position the cursor at the FER Spec field.
2. Set the value with the DATA keys. Refer to the TIA IS-98 minimum performance standards for recommended FER specification.
3. Press the ENTER key or the knob to enter the value.

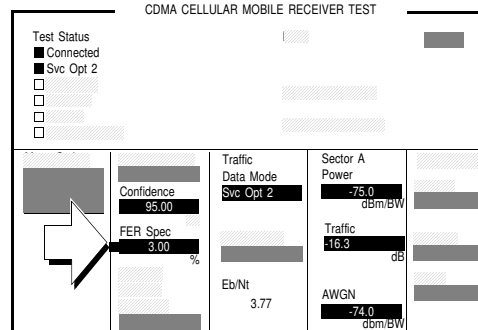

In the FER Spec field, FER is expressed in percent. In the TIA IS-98 standards, FER is expressed without units. Example: If the TIA IS-98 required FER is 0.03, enter 3 in this field.

HP-IB Syntax

"MEAS:CDM:FER:CONF:LIM 3" !sets the FER to 0.03.

6. Set the data rate.

Manual Operation:

1. Position the cursor at the Data Rate field.
2. Press the knob to display a list of choices.
3. Position the cursor at the desired data rate.
 Refer to the TIA IS-98 performance standards for recommended data rate specifications.
4. Press the knob to set the data rate.

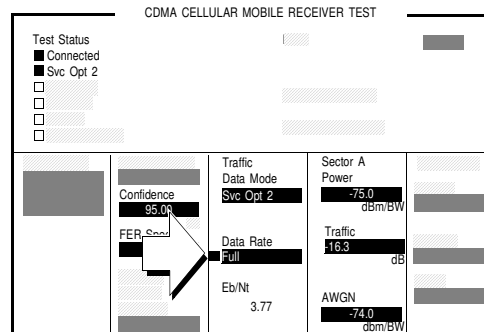

Service Option 2 data rate choices: Full=9600 bps, Half=4800 bps, Quarter=2400 bps, Eighth=1200 bps

Service Option 9 data rate choices: Full=14400 bps, Half=7200 bps, Quarter=3600 bps, Eighth=1800 bps

HP-IB Syntax

"MEAS:CDMA:CALL:TRAF:DATA:RATE 'FULL'" !sets the Data Rate to 9600 or 14400 bps, depending on Traffic Data Mode.

7. Setup the display to show interim results (Optional).

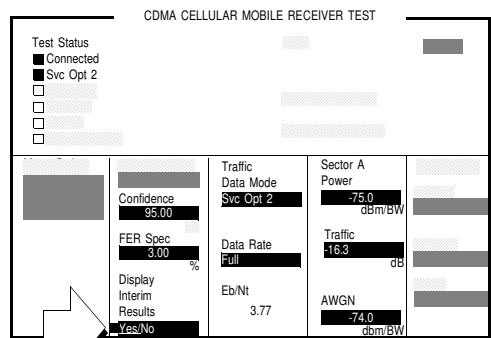
<p>Manual Operation:</p> <ol style="list-style-type: none">1. Position the cursor at the Display Interim Results field.2. Press the knob to toggle the selection to <u>Yes</u>.	 <p>CDMA CELLULAR MOBILE RECEIVER TEST</p> <p>Test Status <input checked="" type="checkbox"/> Connected <input checked="" type="checkbox"/> Svc Opt 2 <input type="checkbox"/> <input type="checkbox"/> <input type="checkbox"/></p> <table border="1"><tr><td>Confidence 95.00</td><td>Traffic Data Mode Svc Opt 2</td><td>Sector A Power -75.0 dbmBW</td></tr><tr><td>FER Spec 3.00 %</td><td>Data Rate Full</td><td>Traffic -16.3 db</td></tr><tr><td>Display Interim Results Yes/No</td><td>Eb/Nt 3.77</td><td>AWGN -74.0 dbmBW</td></tr></table>	Confidence 95.00	Traffic Data Mode Svc Opt 2	Sector A Power -75.0 dbmBW	FER Spec 3.00 %	Data Rate Full	Traffic -16.3 db	Display Interim Results Yes/No	Eb/Nt 3.77	AWGN -74.0 dbmBW
Confidence 95.00	Traffic Data Mode Svc Opt 2	Sector A Power -75.0 dbmBW								
FER Spec 3.00 %	Data Rate Full	Traffic -16.3 db								
Display Interim Results Yes/No	Eb/Nt 3.77	AWGN -74.0 dbmBW								

HP-IB Syntax

"DISP:FER:INT:RES `YES` "

8. Arm a single measurement.

Manual Operation:

1. Position the cursor at the Arm field.
2. Press the knob to arm a measurement.

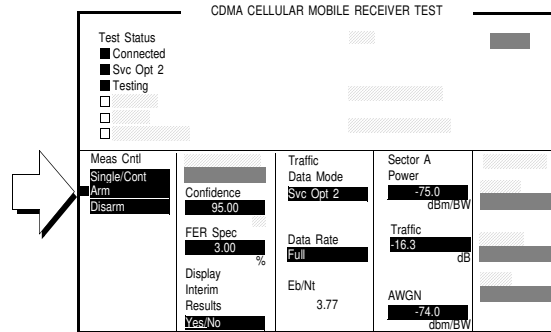

When a measurement is running, the Testing annunciator will be lit.

HP-IB Syntax

"TRIG:MODE:RETR SING" !selects Single measurement mode.

"TRIG:AST 'ARM'" !arms the measurement.

9. Monitor the annunciators to determine test status.

Manual Operation:

The measurement will end when either the Passed, the Failed, or the Max Frames annunciator lights.

The Confidence and FER Spec field settings determine pass/fail criteria. The measurement will end when either the Passed, the Failed, or the Max Frames annunciator lights.

Turning the Confidence field Off causes the FER test to continue until the number of frames entered in the Max Frames field are counted. The Max Frames annunciator will light when Frames Counted equals Max Frames.

HP-IB Help

The following CDMA Status Register Group bits monitor the status of FER testing events:

- Test Passed (Bit 10, BCD 1024)
- Test Failed (Bit 9, BCD 512)
- Max Frames (Bit 8, BCD 256)

These bits are "event" bits only. No condition registers are implemented. Refer to ["CDMA Status Register Group"](#) in the Status Reporting chapter of the *HP 8924C User's Guide* for information about using status bits.

Measurement Overview

1. **"Make a Service Option 2 or 9 call." on page 74.**
 See **"Setting up a Call" on page 52.**
2. **"Set the test parameter Traffic Ec/Ior." on page 75.**
 Screen: CDMA CELLULAR MOBILE RECEIVER TEST
 Enter value in: **Traffic.**
3. **"Set the test parameter AWGN (Ioc)." on page 76.**
 Screen: CDMA CELLULAR MOBILE RECEIVER TEST
 Enter value in: **AWGN**
4. **"Verify correct Eb/Nt reading." on page 77.**

Screen: CDMA CELLULAR MOBILE RECEIVER TEST
Read value in: **Eb/Nt**

5. "Set the FER specification." on page 78.

Screen: CDMA CELLULAR MOBILE RECEIVER TEST
Enter value in: **FER Specs**

6. "Set the data rate." on page 79.

Screen: CDMA CELLULAR MOBILE RECEIVER TEST
Enter value in: **Data Rate**

7. "Setup the display to show interim results (Optional)." on page 80.

Screen: CDMA CELLULAR MOBILE RECEIVER TEST
Start measurement in - **Display Interim Results**

8. "Arm a single measurement." on page 81.

Screen: CDMA CELLULAR MOBILE RECEIVER TEST
Start measurement in: **Meas Cntl, Arm**

9. "Monitor the annunciators to determine test status." on page 82.

Screen: CDMA CELLULAR MOBILE RECEIVER TEST
Observe: **Pass, Fail, or Max Frames**

HPBASIC Programming Example

The following programming example was developed using HPBASIC for Windows. It was tested on an HP 8924C with firmware rev A.02.26.

```
10 ! re-save "c:\hpbasic\app_note\FER_AWGN"
20 ! This program implements CDMA FER test with AWGN.
30 ! This closely follows T38 from the 83217A Software.
40 CLEAR SCREEN
50 OUTPUT 714;"CDMA:CALL:END" !End any call currently connected
60 WAIT 1
70 OUTPUT 714;"*RST"
90 Page_phone
100 CLEAR SCREEN
110 Fer_with_awgn
120 DISP "PROGRAM DONE"
130 END
140 Fer_with_awgn: SUB Fer_with_awgn
150 OUTPUT 714;"CDMA:CELL:ASEC:TRAF -16.3dB;PIL -7dB;SYNC -16dB;PAG -12dB"
```

Chapter 3, CDMA Receiver Tests

Measuring Demodulation of Forward Traffic Channel with AWGN

```
160 OUTPUT 714; "CDMA:CELL:ASEC:BWP -75 dBm"
170 OUTPUT 714; "CDMA:AWGN:BWP -74 dBm;STAT ON"
180 OUTPUT 714; "TRIG:MODE:RETR SINGLE "
190 OUTPUT 714; "DISP CRXT"
200 OUTPUT 714; "MEAS:CDM:FER:MAX:FRAM 5000"
210 OUTPUT 714; "DISP:FER:INT:RES 'YES' "
220 OUTPUT 714; "MEAS:CDM:FER:CONF:INT 95;INT:STAT ON"
230 OUTPUT 714; "MEAS:CDM:FER:CONF:LIMIT .5"
240 OUTPUT 714; "TRIG:AST 'ARM' "
250 FOR Test=1 TO 6
260 SELECT Test
270 CASE 1
280 OUTPUT 714; "CDMA:CELL:ASEC:TRAF -16.3 DB"
290 OUTPUT 714; "CDMA:CALL:TRAF:DATA:RATE 'FULL' "
300 OUTPUT 714; "MEAS:CDM:FER:CONF:LIM 3"
310 CASE 2
320 OUTPUT 714; "CDMA:CELL:ASEC:TRAF -15.8 DB"
330 OUTPUT 714; "CDMA:CALL:TRAF:DATA:RATE 'FULL' "
340 OUTPUT 714; "MEAS:CDM:FER:CONF:LIM 1"
350 CASE 3
360 OUTPUT 714; "CDMA:CELL:ASEC:TRAF -15.6 DB"
370 OUTPUT 714; "CDMA:CALL:TRAF:DATA:RATE 'FULL' "
380 OUTPUT 714; "MEAS:CDM:FER:CONF:LIM .5"
390 CASE 4
400 OUTPUT 714; "CDMA:CELL:ASEC:TRAF -19.1 DB"
410 OUTPUT 714; "CDMA:CALL:TRAF:DATA:RATE 'HALF' "
420 OUTPUT 714; "MEAS:CDM:FER:CONF:LIM 1"
430 CASE 5
440 OUTPUT 714; "CDMA:CELL:ASEC:TRAF -21.6 DB"
450 OUTPUT 714; "CDMA:CALL:TRAF:DATA:RATE 'QUARTER' "
460 OUTPUT 714; "MEAS:CDM:FER:CONF:LIM 1"
470 CASE 6
480 OUTPUT 714; "CDMA:CELL:ASEC:TRAF -24.5 DB"
490 OUTPUT 714; "CDMA:CALL:TRAF:DATA:RATE 'EIGHTH' "
500 OUTPUT 714; "MEAS:CDM:FER:CONF:LIM 1"
510 END SELECT
520 GOSUB Meas
```

```
530 NEXT Test
540 SUBEXIT
550 !
560 Meas:!
570 WAIT 2
580 OUTPUT 714;"TRIG:AST 'ARM' "
590 REPEAT
600 DISP "Measuring FER..."
610 UNTIL FNFer_done
620 OUTPUT 714;"MEAS:CDM:FER?"
630 ENTER 714;Mv
640 Mv=PROUND(Mv,-2)      ! Set to 2 significant digits
650 PRINT "Test ";Test;" RXD Traffic Ch FER% is ";Mv
660 RETURN
670 SUBEND
680 Fer_done: DEF FNFer_done
690 WAIT 1
700 OUTPUT 714;"STATUS:CDMA:EVEN?"
710 ENTER 714;Stat
720 IF BIT(Stat,8) THEN RETURN 1
730 IF BIT(Stat,9) THEN RETURN 2
740 IF BIT(Stat,10) THEN RETURN 3
750 RETURN 0
760 FNEND
770 Page_phone: SUB Page_phone
780 OUTPUT 714;"CDMA:CELL:ASEC:BWP -50 dBm;STAT ON"
790 OUTPUT 714;"CDMA:RFCH 384"!
800 PRINT "WHEN THE MOBILE FINDS SERVICE, PRESS THE CONTINUE SOFTKEY (F2) "
810 DISP "Waiting..."
820 PAUSE
830 OUTPUT 714;"CDMA:CALL:TRAF:DATA:MODE 'SVC OPT 2' "
840 OUTPUT 714;"CDMA:CALL:MAKE"
850 DISP "Mobile is being paged..."
860 REPEAT
870 WAIT .1 !100 mS wait to allow Test Set to handle other tasks
880 OUTPUT 714;"STAT:CDMA:EVENT?"
890 ENTER 714;Event_reg
```

```
900  UNTIL BIT(Event_reg,3)! Monitoring "Connected" annunciator bit
910  CLEAR SCREEN
920  PRINT "Page successful, mobile is connected"
930  SUBEND
```

Measuring Receiver Sensitivity and Dynamic Range

The Test Set performs "Receiver Sensitivity and Dynamic Range" as described in TIA IS-98, "CDMA Receiver Minimum Standards."

During this test, FER is measured with the Test Set first providing a low level signal, then a high level signal.

NOTE:

The following procedure assumes that an instrument PRESET will be performed as part of setting up a call. This clears all settings from other tests that may affect the accuracy of this test, and allows the procedure to begin from a known instrument state.

1. Make a Service Option 2 call.

See "[Setting up a Call](#)" on page 52 if you are not familiar with how this procedure is performed with the Test Set.

After setting up the call, return to this procedure.

NOTE:

The RF path loss between the RF output of the Test Set and the RF input of the MSUT must be corrected for. Correcting for path loss by entering an RF level offset allows the Test Set analyzer's auto-ranging algorithm to work correctly throughout the operating range of the MSUT. Refer to "[Correcting for RF Path Loss](#)" on page 41.

2. Set the test parameter Traffic E_c/I_{or} .

Manual Operation:

1. Press the CDMA SCRNS - RX TEST key to display the CDMA CELLULAR MOBILE RECEIVER TEST screen.
2. Position the cursor at the Traffic field.
3. Set the value with the DATA keys. Refer to the TIA IS-98 performance standards for test parameters.
4. Press the ENTER key or the knob to enter the value.

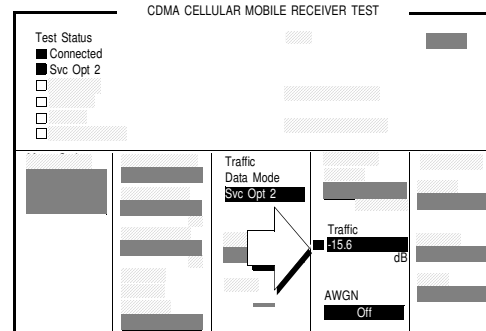

Sector A Pilot E_c/I_{or} has a factory preset value of -7 dB. If it is necessary to change this setting, access the CDMA GENERATOR CONTROL screen. The CDMA GENERATOR CONTROL screen also displays total RF Power .

Traffic E_c/I_{or} is defined as the ratio of the average transmit energy per PN chip for the Forward Traffic Channel to the total transmit power spectral density. Values in this field are expressed in dB, relative to Sector A Power.

HP-IB Syntax

"CDMA:CELL:ASEC:TRAF -15.6" !sets Sector A Traffic to -15.6 dB.

3. Adjust Sector A Power (test parameter I_{or}).

Manual Operation:

1. Position the cursor at the Sector A Power field.
2. Set the value with the DATA keys. Refer to the TIA IS-98 performance standards for recommended test parameters.
3. Press the ENTER key or the knob to enter the value.

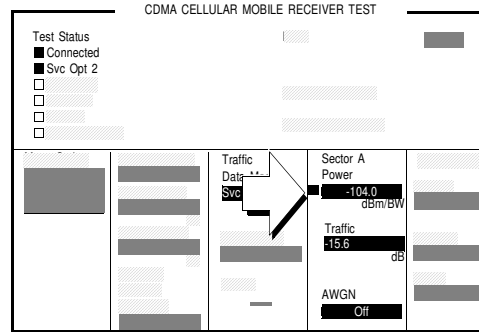

The value for I_{or} is referred to as Sector A Power.

HP-IB Syntax

"CDMA:CELL:ASEC -104" !sets Sector A Power to -104 dBm/BW.

4. Set the FER specification.

Manual Operation:

1. Position the cursor at the FER Spec field.
2. Set the value with the DATA keys. Refer to the TIA IS-98 performance standards for recommended FER specification.
3. Press the ENTER key or the knob to enter the value.

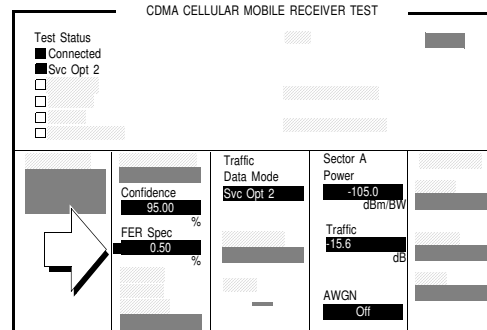

In the FER Spec field, FER is expressed in percent. In the TIA IS-98 standards, FER is expressed without units. Example: If the TIA IS-98 required FER is 0.005, enter 0.5 in this field.

HP-IB Syntax

```
"MEAS:CDM:FER:CONF:LIM 0.5"
```

5. Set the data rate.

Manual Operation:

1. Position the cursor at the Data Rate field.
2. Press the knob to display a list of choices.
3. Position the cursor at the desired data rate.
 Refer to the TIA IS-98 performance standards for recommended data rate specifications.
4. Press the knob to set the data rate.

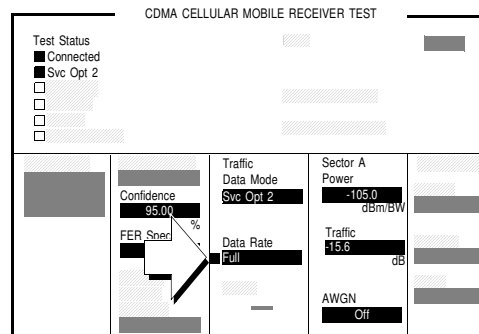

Service Option 2 data rate choices: Full=9600 bps, Half=4800 bps, Quarter=2400 bps, Eighth=1200 bps

Service Option 9 data rate choices: Full=14400 bps, Half=7200 bps, Quarter=3600 bps, Eighth=1800 bps

HP-IB Syntax

"MEAS:CDMA:CALL:TRAF:DATA:RATE 'FULL' "

6. Setup display to show interim results (Optional).

Manual Operation:

1. Position the cursor at the Display Interim Results field.
2. Press the knob to toggle the selection to **Yes**.

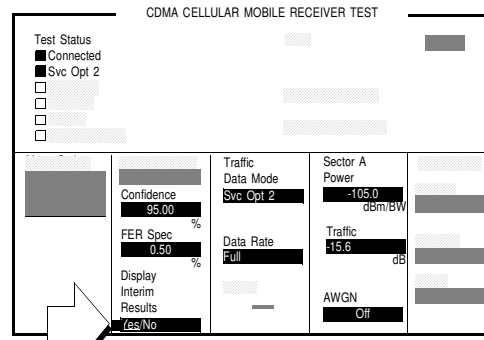

HP-IB Syntax

"DISP:FER:INT:RES 'YES' "

7. Arm a single measurement.

Manual Operation:

1. Position the cursor at the Arm field.
2. Press the knob to arm a measurement.

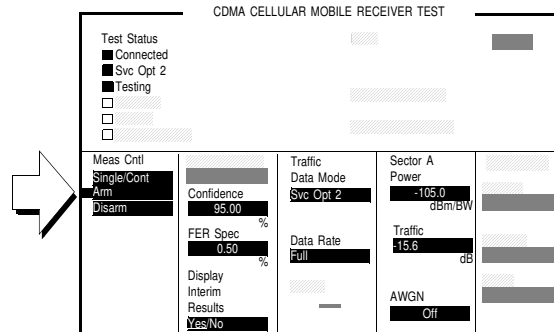

When a measurement is running, the Testing annunciator will be lit.

HP-IB Syntax

"TRIG:MODE:RETR SING" !selects Single measurement mode.

"TRIG:AST 'ARM'" !starts the FER measurement.

"TRIG" !starts the FER measurement and other "active" measurements.

8. Monitor the annunciators to determine test status.

Manual Operation:

The measurement will end when either the Passed, the Failed, or the Max Frames annunciator lights.

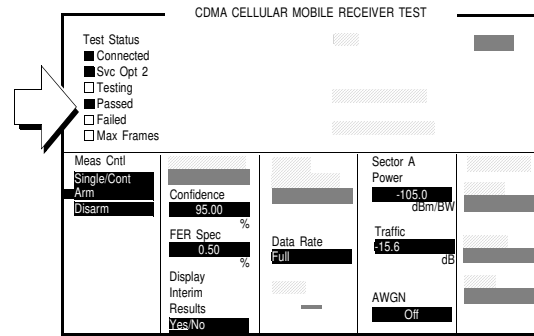

The Confidence and FER Spec field settings determine pass/fail criteria. The measurement will end when either the Passed, Failed, or Max Frames annunciator lights.

Turning the Confidence field off will force the measurement to continue until the number of frames entered in the Max Frames field is counted.

HP-IB Help

The following CDMA Status Register Group bits monitor the status of FER testing:

- Test Passed (BCD 1024)
- Test Failed (BCD 512)
- Max Frames (BCD 256)

These bits are "event" bits only, which means that no condition registers are implemented. Refer to "[CDMA Status Register Group](#)" in the Status Reporting chapter of the *HP 8924C User's Guide* for information about using status bits.

Measurement Overview

1. "[Make a Service Option 2 call.](#)" on page 88.

See "[Setting up a Call](#)" on page 52.

2. "[Set the test parameter Traffic Ec/Ior.](#)" on page 89.

Screen: CDMA CELLULAR MOBILE RECEIVER TEST
Enter value in: **Traffic**

3. "[Adjust Sector A Power \(test parameter Îor\).](#)" on page 90.

Screen: CDMA CELLULAR MOBILE RECEIVER TEST
Enter value in: **Sector A Power**

4. "Set the FER specification." on page 91.

Screen: CDMA CELLULAR MOBILE RECEIVER TEST
Enter value in: **FER SPECS**

5. "Set the data rate." on page 92.

Screen: CDMA CELLULAR MOBILE RECEIVER TEST
Enter value in: **Data Rate**

6. "Setup display to show interim results (Optional)." on page 93.

Screen: CDMA CELLULAR MOBILE RECEIVER TEST
Start measurement in - **Display Interim Results**

7. "Arm a single measurement." on page 94.

Screen: CDMA CELLULAR MOBILE RECEIVER TEST
Start measurement in: **Meas Cntl, Arm**

8. "Monitor the annunciators to determine test status." on page 95.

Screen: CDMA CELLULAR MOBILE RECEIVER TEST
Observe: **Pass, Fail, or Max Frames**

HPBASIC Programming Example

The following programming example was developed using HPBASIC for Windows. It was tested on an HP 8924C with firmware rev A.02.26.

```
10 ! re-save "c:\hpbasic\Sens_rng"
20 ! This program implements CDMA RX Sensitivity and Dynamic Range"
30 This closely follows T39 from the 83217A Software.
40 Initialize_ts
50 OUTPUT 714;"TRIG:MODE:RETR SINGLE"
60 Page_phone
70 CLEAR SCREEN
80 Sensitivity_rng
90 OUTPUT 714;"CDMA:CALL:END"
100 DISP "PROGRAM DONE"
110 END
120 Sensitivity_rng: SUB Sensitivity_rng
130 DISP "Measuring mobile sensitivity"
140 OUTPUT 714;"CDMA:CELL:ASEC:PIL -7dB;SYNC -16dB"
145 OUTPUT 714;"CDMA:CELL:ASEC:PAG -12dB;TRAF -15.6dB"
150 OUTPUT 714;"CDMA:CELL:ASEC:BWP -90 dBm"
```



```
160 OUTPUT 714;"CDMA:CELL:ASEC:BWP -104 dBm"
170 OUTPUT 714;"DISP CRXT"
180 OUTPUT 714;"MEAS:CDM:FER:MAX:FRAM 5000"
190 OUTPUT 714;"MEAS:CDM:FER:STAT ON"
200 OUTPUT 714;"MEAS:CDM:FER:CONF:INT 95;INT:STAT ON"
210 OUTPUT 714;"MEAS:CDM:FER:CONF:LIMIT .5"
220 GOSUB Meas ! Sensitivity test
230 Lvl=-25
240 OUTPUT 714;"CDMA:CELL:ASEC:BWP -25 dBm"
250 GOSUB Meas
260 SUBEXIT
270 Meas:      !
280 Arm_fer
290 Max_f=0
300 P_f=0
310 Cnt=0
320 REPEAT
330   Cnt=Cnt+1340      UNTIL FNFer_done(Mv,P_f,Max_f) OR Cnt>125
350 IF Cnt>125 THEN
360 PRINT "Sensitivity test timed out"
370 ELSE
380 Mv=PROUND(Mv,-2)
390 PRINT "RXD Sensitivity FER% = ";Mv
400 END IF
410 RETURN
420 SUBEND
430 Fer_done: DEF FNFer_done(Mv,P_f,Max_f)
440 WAIT 1
450 OUTPUT 714;"STATUS:MEAS:CONDITION?"
460 ENTER 714;Meas
470 OUTPUT 714;"MEAS:CDM:FER?"
480 ENTER 714;Mv
490 IF BIT(Meas,0) THEN RETURN 0 ! Not done
500 OUTPUT 714;"STATUS:CDMA?"
510 ENTER 714;Stat
520 IF BIT(Stat,8) THEN Max_f=1
530 IF BIT(Stat,10) THEN P_f=1
```

Chapter 3, CDMA Receiver Tests

Measuring Receiver Sensitivity and Dynamic Range

```
540 RETURN 1
550 FNEND
560 Arm_fer: SUB Arm_fer
570 OUTPUT 714;"TRIG"
580 REPEAT
590 WAIT .1
600 OUTPUT 714;"STATUS:MEAS:CONDITION?"
610 ENTER 714;Meas
620 UNTIL BIT(Meas,0)
630 SUBEND
640 Page_phone: SUB Page_phone
650 OUTPUT 714;"CDMA:CELL:ASEC:BWP -50 dBm;STAT ON"
660 OUTPUT 714;"CDMA:RFCH 384" !
670 PRINT "WHEN THE MOBILE FINDS SERVICE, PRESS"
675 PRINT "THE CONTINUE SOFTKEY (F2) "
680 DISP "Waiting..."
690 PAUSE
700 OUTPUT 714;"CDMA:CALL:TRAF:DATA:MODE 'SVC OPT 2' "
710 OUTPUT 714;"CDMA:CALL:MAKE"
720 DISP "Mobile is being paged..."
730 REPEAT
740 WAIT .1 !100 mS wait to allow Test Set to handle other tasks
750 OUTPUT 714;"STAT:CDMA:EVENT?"
760 ENTER 714;Event_reg
770 UNTIL BIT(Event_reg,3)! Monitoring "Connected" annunciator bit
780 CLEAR SCREEN
790 PRINT "Page successful, mobile is connected"
800 SUBEND
810 Initialize_ts: SUB Initialize_ts
820 CLEAR 714
830 CLEAR SCREEN
840 DISP "Initializing...."
850 OUTPUT 714;"*RST"! Reset
860 WAIT 5
870 OUTPUT 714;"CONF:OFL:MODE 'ON';RFIN -2"! External Path Loss
880 SUBEND
```

Measuring Single Tone Desensitization

The Test Set performs the necessary call processing and FER measurements for "Single Tone Desensitization," but requires a single external continuous wave (CW) signal generator to perform this test as described in TIA IS-98, "CDMA Receiver Minimum Standards."

During this test, an interfering signal (tone) is summed with the Test Set's output and the FER is measured.

Test Prerequisites

Determine Cable Path Loss When using cables to connect the equipment, the path loss for the cable(s) should be determined. The Test Set can be used for measuring path loss.

Refer to "[Correcting for RF Path Loss](#)" on page 41 if necessary, and then return to this procedure.

Recommended Equipment

CW Generator Specifications for the CW signal generator are provided in TIA IS-98, "CDMA Standard Test Conditions." At the time of this printing, the following signal generators meet these specifications:

- HP 8656B
- HP 8647A
- HP 8657D

Combiner The Combiner used in this test must provide adequate isolation between the Signal Generator output and the signals generated by the MSUT and the Test Set. At least 15 dB isolation is recommended.

1. Connect the MSUT and combiner as shown.

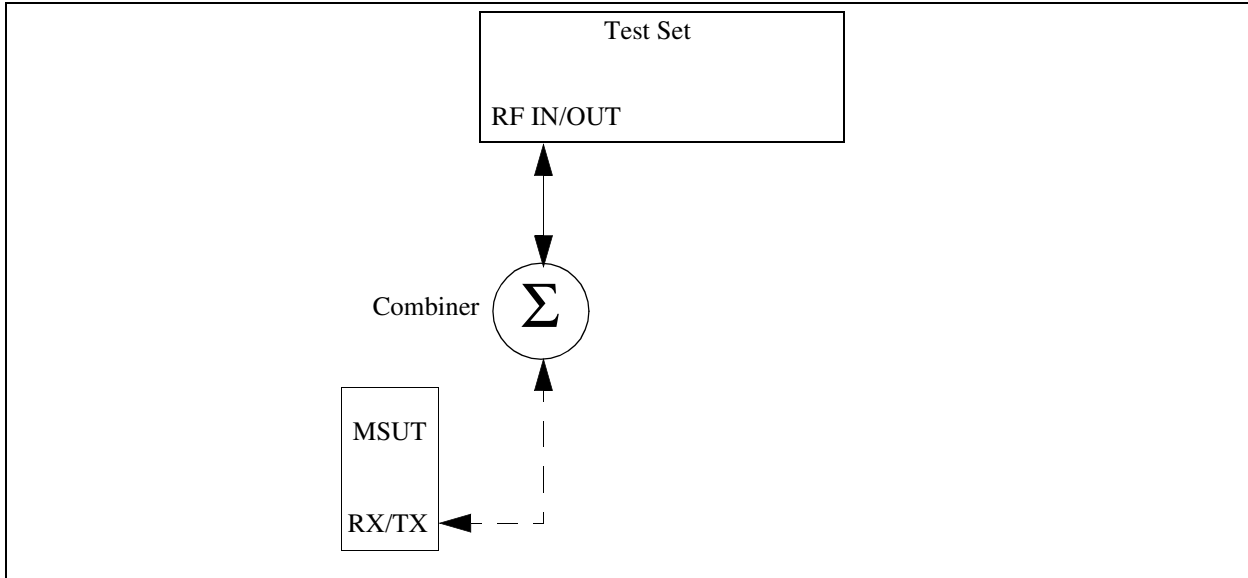

2. Make a Service Option 2 call.

See "[Setting up a Call](#)" on [page 52](#) if you are not familiar with how this procedure is performed with the Test Set.

After setting up the call, return to this procedure.

3. Set the signal generator's interfering tone to the required frequency and amplitude.

Manual Operation:

Refer to TIA IS-98 performance for test parameters.

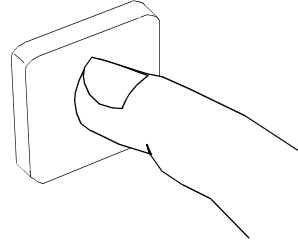

To display the carrier frequency that the mobile station is assigned to receive,

- 1. Press then release the blue SHIFT key, then press the TESTS key to select the CONFIGURE screen.*
- 2. Select Freq in the RF Display field.*
- 3. Press the CALL CTRL key.*

The carrier frequency will be displayed in the RF Channel field.

4. Connect the test equipment as shown.

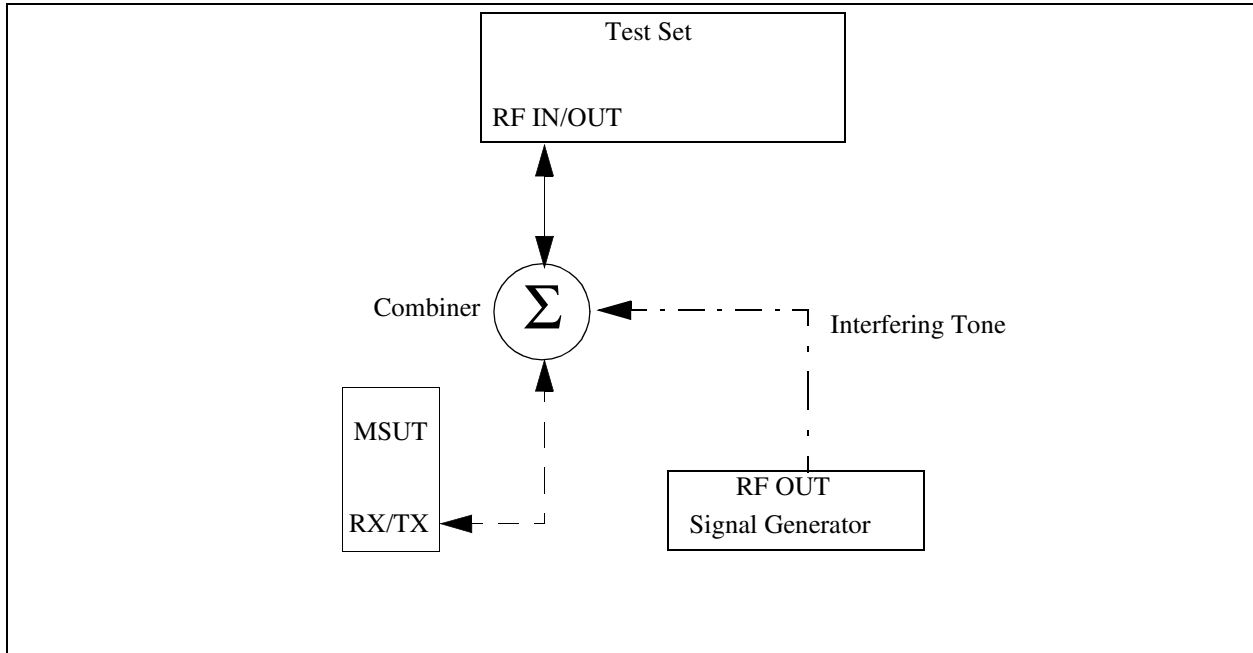

5. Set the test parameter Traffic Ec/Ior.

Manual Operation:

1. Press the CDMA SCRNS - RX TEST key to display the CDMA CELLULAR MOBILE RECEIVER TEST screen.
2. Position the cursor at the Traffic field.
3. Set the value with the DATA keys. Refer to the TIA IS-98 performance standards for test parameters.
4. Press the ENTER key or knob to enter the value.

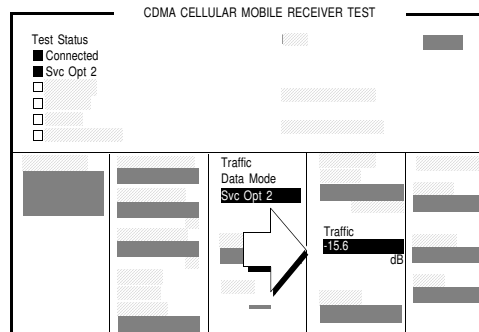

Values in this field are expressed in dB, relative to Sector A Power.

Sector A Pilot E_c/I_{or} has a factory preset value of -7 dB. If it is necessary to change this setting, access the CDMA GENERATOR CONTROL screen.

HP-IB Help

When the CDMA CELLULAR MOBILE RECEIVER TEST screen is accessed over the HP-IB, continuous FER measurements are automatically armed.

Unless the **Display Interim Results** field is set to **Yes**, you will not see any results.

HP-IB Syntax

"DISP CRXT" !displays the CDMA CELLULAR MOBILE RECEIVER TEST screen.

"CDMA:CELL:ASEC:TRAF -15.6" !sets Sector A Traffic Ec/Ior to -15.6 dB

6. Set the test parameter \hat{I}_{or} .

Manual Operation:

1. Position the cursor at the Sector A Power field.
2. Set the value with the DATA keys. Refer to the TIA IS-98 performance standards for test parameters.
3. Press the ENTER key or the knob to enter the value.

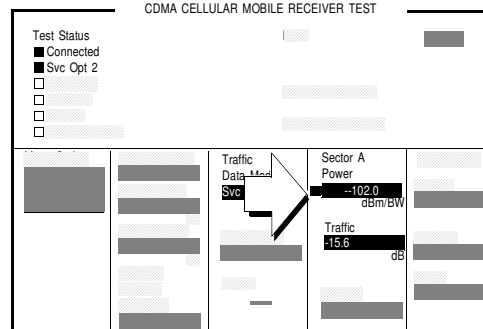

The value for Sector A Power is referred to as I_{or} .

HP-IB Syntax

"CDMA:CELL:ASEC -102" !sets Sector A Ior to -102 dBm/BW

7. Set the FER specification.

Manual Operation:

1. Position the cursor at the FER Spec field.
2. Set the value with the DATA keys. Refer to the TIA IS-98 performance standards for recommended FER specification.
3. Press the ENTER key or the knob to enter the value.

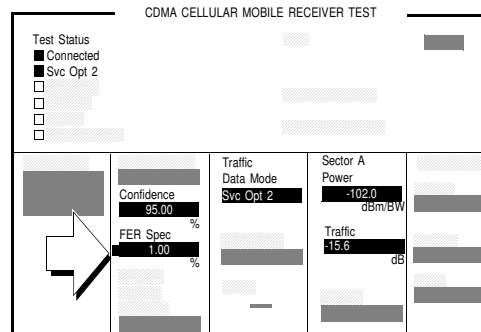

In the FER Spec field, FER is expressed in percent. In the TIA IS-98 standards, FER is expressed without units. Example: If the TIA IS-98 required FER is 0.01, enter 1 in this field.

HP-IB Syntax

"MEAS:CDM:FER:CONF:LIM 1" !sets the FER specification to 1%.

8. Set the data rate.

Manual Operation:

1. Position the cursor at the Data Rate field.
2. Press the knob to display a list of choices.
3. Position the cursor at the desired data rate.
Refer to the TIA IS-98 performance standards for recommended data rate specifications.
4. Press the knob to set the data rate.

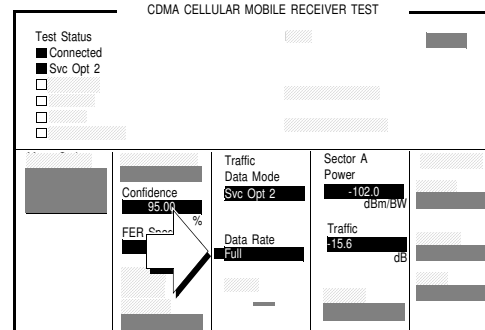

HP-IB Syntax

"MEAS:CDMA:CALL:TRAF:DATA:RATE 'FULL'" !sets the data rate to 9600 (for Svc Opt 2) or 14400 (for Svc Opt 9) bps.

9. Set up display to show interim results (Optional).

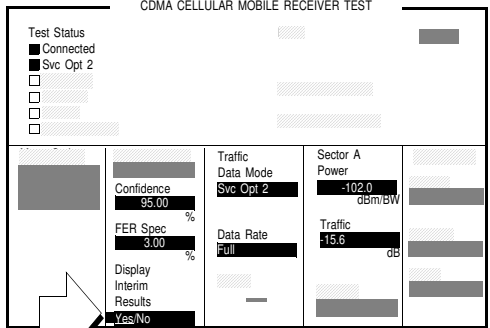
<p>Manual Operation:</p> <ol style="list-style-type: none">1. Position the cursor at the Display Interim Results field.2. Press the knob to toggle the selection to <u>Yes</u>.	 <p>CDMA CELLULAR MOBILE RECEIVER TEST</p> <p>Test Status <input checked="" type="checkbox"/> Connected <input checked="" type="checkbox"/> Svc Opt 2 <input type="checkbox"/> <input type="checkbox"/> <input type="checkbox"/></p> <table border="1"><tr><td>Confidence 95.00</td><td>Traffic Data Mode Svc Opt 2</td><td>Sector A Power -102.0 dBm/BW</td></tr><tr><td>FER Spec 3.00 %</td><td>Data Rate 7.0</td><td>Traffic -15.6 dB</td></tr></table> <p>Display Interim Results <u>Yes</u> No</p>	Confidence 95.00	Traffic Data Mode Svc Opt 2	Sector A Power -102.0 dBm/BW	FER Spec 3.00 %	Data Rate 7.0	Traffic -15.6 dB
Confidence 95.00	Traffic Data Mode Svc Opt 2	Sector A Power -102.0 dBm/BW					
FER Spec 3.00 %	Data Rate 7.0	Traffic -15.6 dB					

HP-IB Syntax

"DISP:FER:INT:RES 'YES' " !displays interim FER test results.

10. Arm a single measurement.

Manual Operation:

1. Position the cursor at the Arm field.
2. Press the knob to arm a measurement.

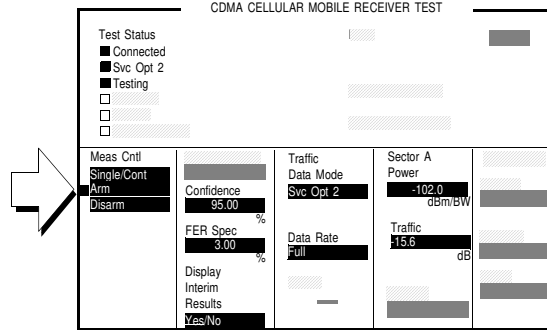

When a measurement is running, the Testing annunciator will be lit.

HP-IB Syntax

"TRIG:MODE:RETR SING" !selects Single measurement mode.

"TRIG:AST 'ARM' " !arms the measurement.

11. Monitor the annunciators to determine test status.

<p>Manual Operation:</p> <p>The measurement will end when either the Passed, the Failed, or the Max Frames annunciator lights.</p>	
<p><i>The Confidence and FER Spec field settings determine pass/fail criteria. The measurement will end when either the Passed, the Failed, or the Max Frames annunciator lights.</i></p> <p><i>Turning the Confidence field off will force the measurement to continue until the number of frames entered in the Max Frames field is counted.</i></p>	

HP-IB Help

The following CDMA Status Register Group bits monitor the status of FER testing:

- Test Passed (BCD 1024)
- Test Failed (BCD 512)
- Max Frames (BCD 256)

These bits are "event" bits only. No condition registers are implemented. Refer to ["CDMA Status Register Group"](#) in the Status Reporting chapter of the *HP 8924C User's Guide* for information about using status bits.

Measurement Overview

1. **"Connect the MSUT and combiner as shown." on page 100.**
 MSUT and Combiner.
2. **"Make a Service Option 2 call." on page 117.**
 See **"Setting up a Call" on page 52.**
3. **"Tune the signal generators to the required frequencies and power levels (amplitudes)." on page 118.**
 Required frequency and amplitude.
4. **"Connect equipment as shown." on page 119.**

Signal Generator.

5. "Set the test parameter Traffic Ec/Ior." on page 120.

Screen: CDMA CELLULAR MOBILE RECEIVER TEST
Enter value in: **Traffic**.

6. "Set the test parameter Ior ." on page 121.

Screen: CDMA CELLULAR MOBILE RECEIVER TEST
Enter value in: **Sector A Power**

7. "Set the FER specification." on page 122.

Screen: CDMA CELLULAR MOBILE RECEIVER TEST
Enter value in: **FER Specs**

8. "Set the data rate." on page 123.

Screen: CDMA CELLULAR MOBILE RECEIVER TEST
Enter value in: **Data Rate**

9. "Set up display to show interim results (Optional)." on page 108.

Screen: CDMA CELLULAR MOBILE RECEIVER TEST
Start measurement in - **Display Interim Results**

10. "Arm a single measurement." on page 109.

Screen: CDMA CELLULAR MOBILE RECEIVER TEST
Start measurement in: **Meas Cntl, Arm**

11. "Monitor the annunciators to determine test status." on page 110.

Screen: CDMA CELLULAR MOBILE RECEIVER TEST
Observe: **Passed, Failed, or Max Frames**

Programming Example

The following programming example illustrates the IS-98 recommended procedure for measuring Single Tone Desensitization.

```
10 ! RE-STORE "c:\hpbasic\setrain\single_tone"  
20 ! This program measures Single Tone Desensitization  
26 Test=1  
27 Loss=1.5 !Path loss  
30 OUTPUT 714; "*CLS"  
40 CLEAR SCREEN  
50 CLEAR 714  
60 OUTPUT 714; "CDMA:CALL:END"  
70 WAIT 1
```

Chapter 3, CDMA Receiver Tests

Measuring Single Tone Desensitization

```
80 OUTPUT 714;"*RST"
90 WAIT 5
100 OUTPUT 714;"MEAS:CDM:RHO:STAT OFF" !Rho is not needed
110 Page_phone!Makes the call
120 !
130 Meas(900,Test,Loss) !Makes FER measurement with 900 kHz offset
140 CLEAR SCREEN
150 Meas(-900,Test,Loss) !Makes FER measurement with -900 kHz offset
160 !
170 DISP "Program Done"
180 END
190 Page_phone: SUB Page_phone
200 OUTPUT 714;"CDMA:CELL:ASEC:BWP -50 dBm;STAT ON"
210 OUTPUT 714;"CDMA:RFCH 384"
220 PRINT "WHEN THE MOBILE FINDS SERVICE, "
225 PRINT "PRESS THE CONTINUE SOFTKEY (F2) "
230 DISP "Waiting..."
240 PAUSE
250 OUTPUT 714;"CDMA:CALL:TRAF:DATA:MODE 'SVC OPT 2' "
260 OUTPUT 714;"CDMA:CALL:MAKE"
270 DISP "Mobile is being paged..."
280 REPEAT
290 WAIT .1 !100 mS wait to allow Test Set to handle other tasks
300 OUTPUT 714;"STAT:CDMA:PTR 8"
310 OUTPUT 714;"STAT:CDMA:EVENT?"
320 ENTER 714;Event_reg
330 UNTIL BIT(Event_reg,3)! Monitoring "Connected" annunciator bit
340 CLEAR SCREEN
350 PRINT "Page successful, mobile is connected"
360 SUBEND
370 Meas: SUB Meas(Tone1,Test,Loss)
380 OUTPUT 714;"RFG:FREQ?"
390 ENTER 714;Rf_freq
400 CLEAR SCREEN
410 PRINT "TEST ";VAL$(Test)&":"
411 PRINT
414 PRINT USING "K,4D.2D,K";"1. SET UP SIG GEN FREQUENCY TO", (Rf_freq+Tone1*1.E+3)/
```



```
1.E+6," MHZ"  
423 IF Test=1 THEN  
430 PRINT "2. SET UP SIG GEN AMPLITUDE TO -30 dBm"  
440 PRINT "3. CONNECT SIG GEN TO MOBILE INPUT THROUGH COMBINER"  
441END IF  
450 PRINT  
460 PRINT "PRESS CONTINUE TO RUN FER TEST ";VAL$(Test)  
470 PRINT  
480 PAUSE  
490 CLEAR SCREEN  
500 OUTPUT 714;"TRIG:MODE:RETR SINGLE"  
520 OUTPUT 714;"CONF:OFL:MODE 'ON' "  
530 OUTPUT 714;"CONF:OFL:RFIN ";Loss  
535 OUTPUT 714;"DISP CRXT;CDMA:CELL:ASEC:PIL -7"  
540 OUTPUT 714;"DISP CRXT;CDMA:CELL:ASEC:TRAF -15.6"  
550 OUTPUT 714;"CDMA:CELL:ASEC -90"  
560 OUTPUT 714;"MEAS:CDM:FER:CONF:LIM 1"  
570 OUTPUT 714;"CDMA:CALL:TRAF:DATA:RATE 'FULL' "  
580 OUTPUT 714;"DISP:FER:INT:RES 'YES' "  
590 OUTPUT 714;"TRIG"  
600 REPEAT  
610 WAIT 1  
620 DISP "FER Test ";VAL$(Test);" is running..."  
630 OUTPUT 714;"STAT:CDMA:EVEN?"  
640 ENTER 714;Evt  
660 UNTIL Evt<>0  
661 DISP "FER Test ";VAL$(Test);" is done"  
662 OUTPUT 714;"MEAS:CDM:FER?"  
663 ENTER 714;Fer  
670 SELECT Evt  
680 CASE 256  
685 PRINT "FER TEST ";VAL$(Test);" REACHED MAX FRAMES WITH FER =";Fer  
690 CASE 512  
695 PRINT "FER TEST ";VAL$(Test);" FAILED WITH FER =";Fer  
700 CASE 1024  
705 PRINT "FER TEST ";VAL$(Test);" PASSED WITH FER =";Fer  
710 END SELECT
```

Chapter 3, CDMA Receiver Tests

Measuring Single Tone Desensitization

```
711 IF Test=1 THEN
712 Test=Test+1
714 PRINT
720 PRINT "PRESS CONTINUE TO RUN FER TEST ";VAL$(Test)
730 PAUSE
731 END IF
740 SUBEND
```

Measuring Intermodulation Spurious Response Attenuation

The Test Set performs the necessary call processing and FER measurements for "Intermodulation Spurious Response Attenuation," but requires two external continuous wave (CW) signal generators to perform this test as described in TIA IS-98, "CDMA Receiver Minimum Standards."

During this test, two interfering signals (tones) are summed with the Test Set's output and FER is measured.

Test Prerequisites

Determine Cable Path Loss

When using cables to connect the equipment, the path loss for the cable(s) should be determined. The Test Set can be used as a source to measure path loss.

Refer to "[Correcting for RF Path Loss](#)" on page 41 if necessary, and then return to this procedure.

Recommended Equipment

CW Generators (2)

Specifications for the two CW signal generators are provided in TIA IS-98, "CDMA Standard Test Conditions." At the time of this printing, the following equipment meets these specifications:

- HP 8656B
- HP 8647A
- HP 8657D

Combiners (2)

The combiners should provide at least 15 dB of isolation between sources.

1. Connect MSUT and combiner as shown.

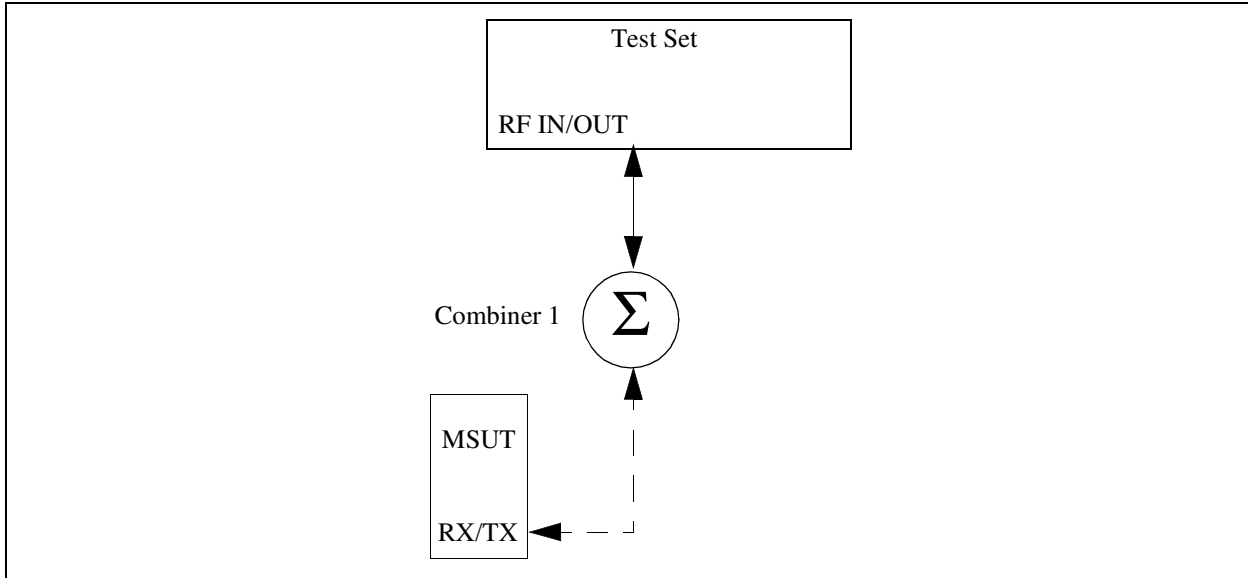

2. Make a Service Option 2 call.

See "[Setting up a Call](#)" on page 52 if you are not familiar with how this procedure is performed with the Test Set.

After setting up the call, return to this procedure.

3. Tune the signal generators to the required frequencies and power levels (amplitudes).

Manual Operation:

Refer to the TIA IS-98 performance standards for test parameters.

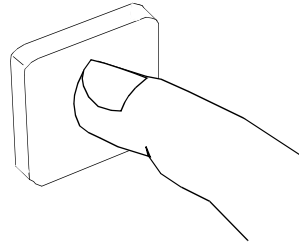

To display the carrier frequency that the mobile station is assigned to receive,

- 1. Press then release the blue SHIFT key, then press the TESTS key to select the CONFIGURE screen.*
- 2. Select Freq in the RF Display field.*
- 3. Press the CALL CTRL key.*

The carrier frequency will be displayed in the RF Channel field.

4. Connect equipment as shown.

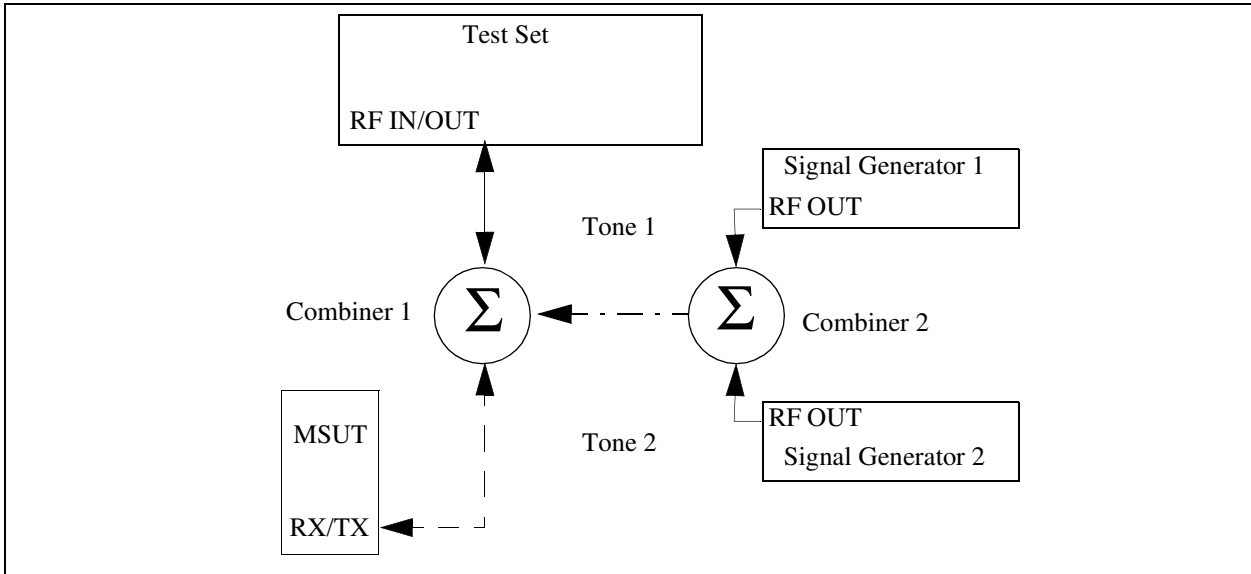

5. Set the test parameter Traffic E_c/I_{or} .

Manual Operation:

1. Press the CDMA SCRNS - RX TEST key to display the CDMA CELLULAR MOBILE RECEIVER TEST screen.
2. Position the cursor at the Traffic field.
3. Set the value with the DATA keys. Refer to the TIA IS-98 performance standards for test parameters.
4. Press the ENTER key or the knob to enter the value.

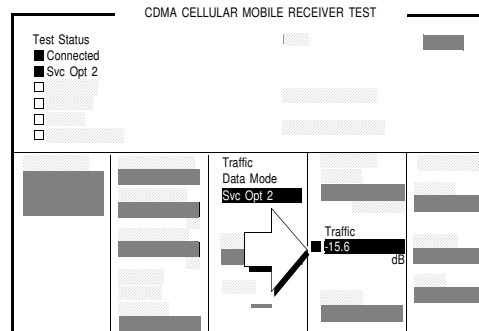

Values in this field are expressed in dB, relative to Sector A Power.

Sector A Pilot E_c/I_{or} has a factory preset value of -7 dB. If it is necessary to change this setting, access the GEN CTRL screen. The GEN CTRL screen also displays total RF Power .

HP-IB Help

When the CDMA CELLULAR MOBILE RECEIVER TEST screen is accessed over the HP-IB, continuous FER measurements are automatically armed. Unless the **Display Interim Results** field is set to **Yes**, you will not see any results until the first test completes.

HP-IB Syntax

"DISP CRXT"

"CDMA:CELL:ASEC:TRAF -15.6"

6. Set the test parameter \hat{I}_{Or} .

Manual Operation:

1. Position the cursor at the Sector A Power field.
2. Set the value with the DATA keys. Refer to the TIA IS-98 performance standards for test parameters.
3. Press the ENTER key or the knob to enter the value.

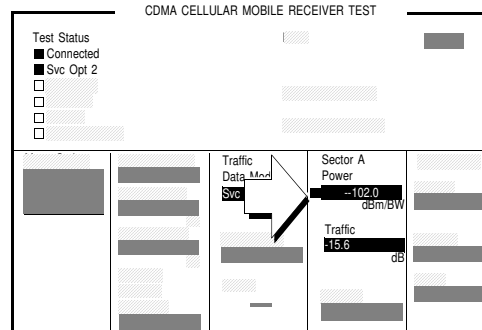

The value for Sector A Power is referred to as I_{Or} .

HP-IB Syntax

"CDMA:CELL:ASEC -102"

7. Set the FER specification.

Manual Operation:

1. Position the cursor at the FER Spec field.
2. Set the value with the DATA keys. Refer to the TIA IS-98 performance standards for recommended FER specification.
3. Press the ENTER key or the knob to select the value.

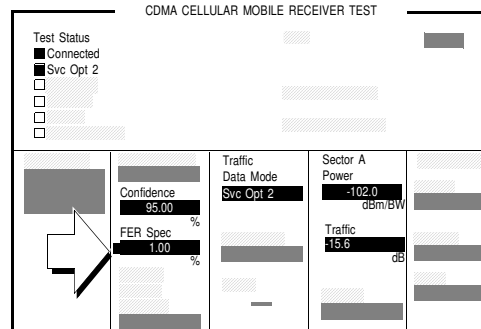

In the FER Spec field, FER is expressed in percent. In the TIA IS-98 standards, FER is expressed without units. Example: If the TIA IS-98 required FER is 0.01, enter 1 in this field.

HP-IB Syntax

```
"MEAS:CDM:FER:CONF:LIM 1"
```

8. Set the data rate.

Manual Operation:

1. Position the cursor at the Data Rate field.
2. Press the knob to display a list of choices.
3. Position the cursor at the desired data rate.
 Refer to the TIA IS-98 performance standards for recommended data rate specifications.
4. Press the knob to set the data rate.

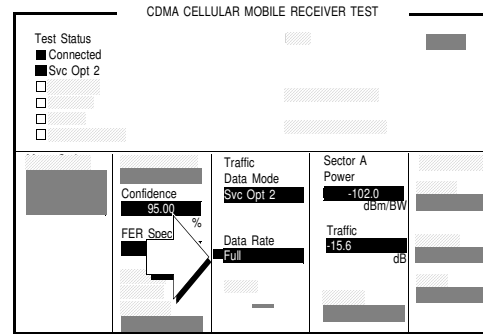

Service Option 2 data rate choices: Full=9600 bps, Half=4800 bps, Quarter=2400 bps, Eighth=1200 bps

Service Option 9 data rate choices: Full=14400 bps, Half=7200 bps, Quarter=3600 bps, Eighth=1800 bps

HP-IB Syntax

"MEAS:CDMA:CALL:TRAF:DATA:RATE `FULL`"

9. Set up the display to show interim results (Optional).

<p>Manual Operation:</p> <ol style="list-style-type: none">1. Position the cursor at the Display Interim Results field.2. Press the knob to toggle the selection to Yes.	<p>CDMA CELLULAR MOBILE RECEIVER TEST</p> <p>Test Status ■ Connected ■ Svc Opt 2 □ □ □</p> <table border="1"><tr><td>Confidence</td><td>95.00</td><td>%</td></tr><tr><td>FER Specs</td><td>3.00</td><td>%</td></tr><tr><td>Display Interim Results</td><td>Yes/No</td><td></td></tr><tr><td>Traffic Data Mode</td><td>Svc Opt 2</td><td></td></tr><tr><td>Data Rate</td><td>Full</td><td></td></tr><tr><td>Sector A Power</td><td>-102.0</td><td>dBm/BW</td></tr><tr><td>Traffic</td><td>15.6</td><td>dB</td></tr></table>	Confidence	95.00	%	FER Specs	3.00	%	Display Interim Results	Yes/No		Traffic Data Mode	Svc Opt 2		Data Rate	Full		Sector A Power	-102.0	dBm/BW	Traffic	15.6	dB
Confidence	95.00	%																				
FER Specs	3.00	%																				
Display Interim Results	Yes/No																					
Traffic Data Mode	Svc Opt 2																					
Data Rate	Full																					
Sector A Power	-102.0	dBm/BW																				
Traffic	15.6	dB																				

HP-IB Syntax

"DISP:FER:INT:RES `YES` "

10. Arm a single measurement.

Manual Operation:

1. Position the cursor at the Arm field.
2. Press the knob to arm a measurement.

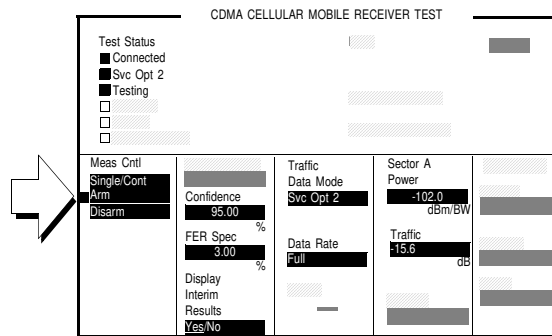

When a measurement is running, the Testing annunciator will be lit.

HP-IB Syntax

"TRIG:MODE:RETR SING" !selects Single measurement mode.

"TRIG:AST 'ARM' " !arms the measurement.

11. Monitor the annunciators to determine test status.

<p>Manual Operation:</p> <p>The measurement will end when either the Passed, the Failed, or the Max Frames annunciator lights.</p>	
<p><i>The Confidence and FER Spec field settings determine pass/fail criteria. The measurement will end when either the Passed, the Failed, or the Max Frames annunciator lights.</i></p> <p><i>Turning the Confidence field off will force the measurement to continue until the number of frames entered in the Max Frames field are counted.</i></p>	

HP-IB Help

The following CDMA Status Register Group bits monitor the status of FER testing:

- Test Passed (BCD 1024)
- Test Failed (BCD 512)
- Max Frames (BCD 256)

These bits are "Event" bits only. No condition registers are implemented. Refer to ["CDMA Status Register Group"](#) in the Status Reporting chapter of the *HP 8924C User's Guide* for information about using status bits.

HP-IB Syntax

"STAT:CDMA:EVEN?" !queries the CDMA Status Register Group event register.

Measurement Overview

1. **"Connect MSUT and combiner as shown." on page 116.**
 MSUT and Combiner
2. **"Make a Service Option 2 call." on page 117.**
 See "Setting up a Call" on page 52.
3. **"Tune the signal generators to the required frequencies and power levels (amplitudes)." on page 118.**

Required frequency and amplitude.

4. "Connect equipment as shown." on page 119.

Signal generator 1 and 2

5. "Set the test parameter Traffic Ec/Ior." on page 120.

Screen: CDMA CELLULAR MOBILE RECEIVER TEST
Enter value in: **Traffic**.

6. "Set the test parameter Ior ." on page 121.

Screen: CDMA CELLULAR MOBILE RECEIVER TEST
Enter value in: **Sector A Power**

7. "Set the FER specification." on page 122.

Screen: CDMA CELLULAR MOBILE RECEIVER TEST
Enter value in: **FER Specs**

8. "Set the data rate." on page 123.

Screen: CDMA CELLULAR MOBILE RECEIVER TEST
Enter value in: **Data Rate**

9. "Set up the display to show interim results (Optional)." on page 124.

Screen: CDMA CELLULAR MOBILE RECEIVER TEST
Start measurement in - **Display Interim Results**

10. "Arm a single measurement." on page 125.

Screen: CDMA CELLULAR MOBILE RECEIVER TEST
Start measurement in - **Meas Cntl, Arm**

11. "Monitor the annunciators to determine test status." on page 126.

Screen: CDMA CELLULAR MOBILE RECEIVER TEST
Observe: **Passed, Failed, or Max Frames**

Measuring Demodulation of Non-Slotted Mode Paging Channel in AWGN

This test retrieves parameters from the mobile station that are used to calculate MER (Message Error Rate). MER indicates the mobile station's ability to receive messages on the Paging Channel while operating in the Mobile Station Idle State.

The Test Set performs "Demodulation of Non-Slotted Mode Paging Channel in Additive White Gaussian Noise" as described in TIA/EIA IS-98A and ANSI J-STD 018. This test is only for phones that operate in non-slotted mode.

Test Prerequisites

Determine the MSUT's Paging Mode

Make sure the MSUT is operating in the non-slotted mode

Determine Cable Path Loss

When using cables to connect the equipment, the path loss for the cable(s) should be determined. The Test Set can be used as a source to measure path loss.

Refer to "[Correcting for RF Path Loss](#)" on [page 41](#) if necessary, and then return to this procedure.

Verify that the Test Set is Configured to Make a Service Option 2 Call

This ensures that the Test Set is configured correctly for making a call to the phone under test. See "[Setting up a Call](#)" on [page 52](#) if you are not familiar with how this procedure is performed with the Test Set.

After setting up the call, press the END CALL key and return to this procedure.

1. Change the Paging Channel Data Rate to "Full".

Manual Operation:

1. Press and release the SHIFT key and then press the CALL CTRL key to display the CDMA CELL SITE CONFIGURATION screen.
2. Position the cursor at the Page Rate field.
3. Use the knob to select "Full" from the list of Choices.

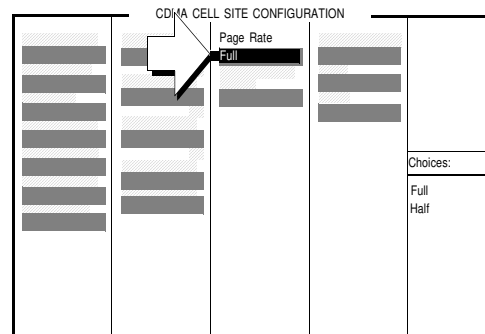

HP-IB Syntax

"DISP CCON;CDMA:CELL:CONF:PAGE:RATE 'Full'" !sets the Paging Channel data rate to 9600 bps (Full).

2. Set the test parameter \hat{I}_{or} / I_{oc} .

Manual Operation:

1. Press the GEN CTRL key to display the CDMA GENERATOR CONTROL screen.
2. Position the cursor at the AWGN field.
3. Enter the appropriate value using the DATA keys. Press the ENTER key or the knob to enter the value. Refer to the applicable standards for test parameters.
4. Position the cursor at the Sctr A Pwr field.
5. Repeat Manual Operation step 3.

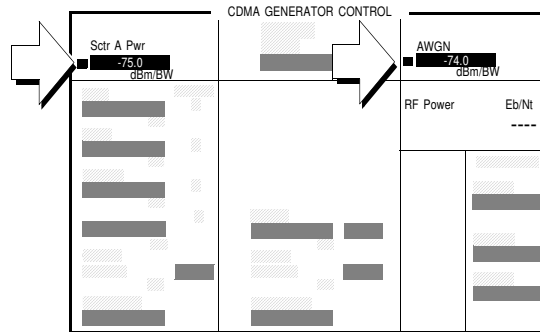

The term used for AWGN in the applicable standard is I_{oc} .

The term used for Sector A Power in the applicable standard is I_{or} .

HP-IB Syntax

"CDMA:AWGN:STAT ON" !turns the Test Set's AWGN generator on.

"CDMA:AWGN -74" !sets AWGN to -74 dBm/BW.

"CDMA:CELL:ASEC -75" !sets Sector A Ior to -75 dBm/BW

3. Set the test parameter Paging E_c/I_{or} .

Manual Operation:

1. Position the cursor at the Paging field.
2. Set the value with the DATA keys. Refer to the TIA/EIA IS-98 performance standards for test parameters.
3. Press the ENTER key or the knob to select the value.

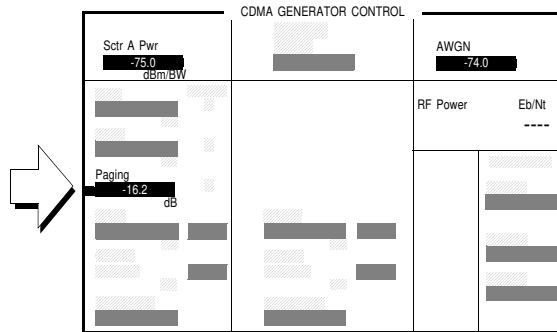

HP-IB Syntax

"CDMA:CELL:ASEC:PAG:POW -16.2 !sets the Sector A Paging channel to -16.2 dB.

4. Cycle power to the mobile station.

Manual Operation:

Wait until the MSUT has found digital service (this should take no longer than about 30 seconds).

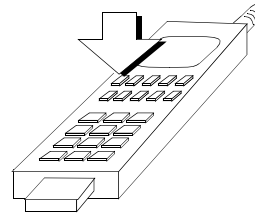

When the mobile station finds CDMA service, it enters the Mobile Station Idle State and initializes the following counters to zero:

PAG_1 - Paging Channel message CRC's (Cyclic Redundancy Check's)

PAG_2 - Invalid Paging Channel messages

PAG_4 - Paging Channel half-frames

The values of these counters are continually updated in the mobile station's table of Retrievable and Settable Parameters.

5. Retrieve the mobile station parameters PAG_1, PAG_2, and PAG_4.

Manual Operation:

1. Press the CALL key. When the call has connected, (watch the mobile station's display for an indication of "Loopback", "SO2", etc.) continue with the next step.
2. Press then release the blue SHIFT key, then press the TX TEST key. This will select the CDMA MOBILE REPORTING screen.
3. Position the cursor in front of the Mobile Parm field, and press the knob to display the list of Choices.
4. Position the cursor in front of mobile parameter PAG_1 in the list of choices and press the knob. When PAG_1 appears in the Mobile Parm field, the mobile station's current value for this parameter is displayed in the field below. Print and record the results using [table 3, "Mobile Station Parameters" on page 136](#).
5. Repeat Manual Operation step 5, substituting PAG_2 and PAG_4 for the mobile parameters.

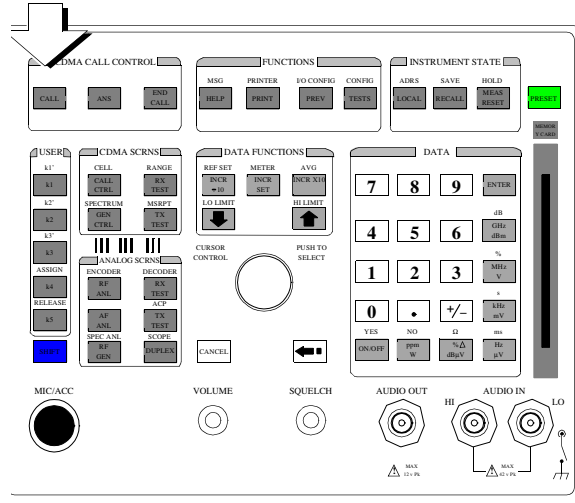

CDMA MOBILE REPORTING				
Status	PN Offset	Strength	Keep	
	Expected	Expected		MS FER 0.00 %
	PN Offset	Strength		Frames 0
Sector A	12	14		Errors 0
Sector B	36	--		

Softer Handoff On/Off	MS FER Report Interval 320 frames	Sctr A Pwr -75.0 dBm/BW	Sctr B Pwr Off	To Screen
T_Add 28	by # frames On/Off	Traffic -15.6 dB	Traffic -16.0 dB	CDMA CALL CNTL
T_Drop 32	by # errors On/Off			Analog RX TEST
T_COMP 5				Config TESTS
T_TDrop 3		RF Pwr -75.0 dBm/BW	Mobile Parm MUXI_REV_1 0	

Each time a Mobile Parm field parameter is selected, a Retrieve Parameters Message is sent to the mobile station and the field below the parameter is updated.

6. End the call and let the test run for 5 seconds or longer.

Manual Operation:

1. Press the END CALL key

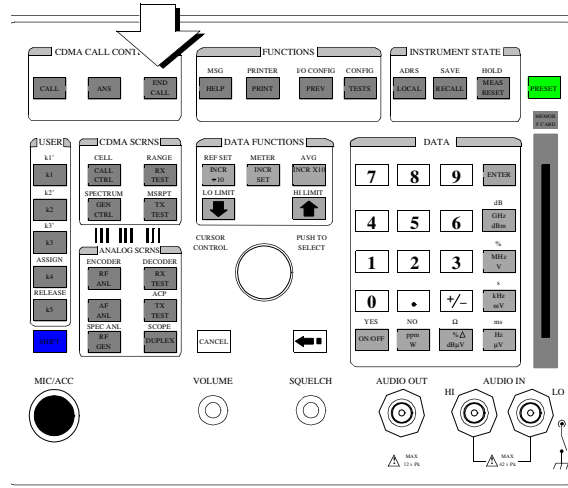

When the call is ended, the mobile station will continue to increment counters PAG_1, PAG_2 and PAG_4.

7. Once again, retrieve the mobile station parameters PAG_1, PAG_2, and PAG_4.

Manual Operation:

1. Press the CALL key. When the call has connected, continue with the next step.
2. Retrieve parameters PAG_1, PAG_2 and PAG_4. Print and record the results using [table 3, "Mobile Station Parameters" on page 136](#)

CDMA MOBILE REPORTING				
Status	PN Offset	Strength	Keep	
	Expected	Expected		MS FER 0.00 %
	PN Offset	Strength		Frames 0
Sector A	12	14		Errors 0
Sector B	36	--		
Softer Handoff On/Off	MS FER Report Interval 320 frames by # frames On/Off	Sctr A Pur -75.0 dBm/BW Traffic -15.6 dB	Sctr B Pur Off Traffic -16.0 dB	To Screen ● CDMA CALL CNTL ○ Analog RX TEST Config TESTS
T_Add 28		RF Pow -75. dBm/BW	Mobile Parm MUX1_REV_1 0	
T_Drop 32				
T_Comp 5				
T_TDrop 3				

Each time a Mobile Parm field parameter is selected, a Retrieve Parameters Message is sent to the mobile station and the field below the parameter is updated.

8. Calculate MER.

$$MER = 1 - \left(\frac{(\Delta PAG1 - \Delta PAG2)}{\Delta PAG4 \times (5/10)} \right)$$

Table 3 Mobile Station Parameters

	Initial Values ^a	Test Values ^b	Delta
PAG_1			
PAG_2			
PAG_4			

- a. Value is obtained by performing Step 5.
- b. Value is obtained by performing Step 7.

Measurement Overview

1. "Change the Paging Channel Data Rate to "Full"." on page 129.
See "Setting up a Call" on page 52.
2. "Set the test parameter \hat{I}_o / I_{oc} ." on page 130.
Screen: CDMA GENERATOR CONTROL.
Enter value in: **AWGN**.
3. "Set the test parameter $Paging Ec/I_{or}$." on page 131.
Screen: CDMA GENERATOR CONTROL.
Enter value in: **PAGING**.
4. "Cycle power to the mobile station." on page 132.
Mobile: Cycle power to the mobile station
5. "Retrieve the mobile station parameters PAG_1, PAG_2, and PAG_4." on page 133.

Screen: CDMA MOBILE REPORTING.

Enter value in: **Mobile Parm**

6. "End the call and let the test run for 5 seconds or longer." on page 134.

Press END CALL key.

7. "Once again, retrieve the mobile station parameters PAG_1, PAG_2, and PAG_4." on page 135.

Screen: CDMA MOBILE REPORTING.

Enter value in: **Mobile Parm**

8. "Calculate MER." on page 136.

CDMA Transmitter Tests

List of CDMA Transmitter Tests

- "Measuring Waveform Quality" on page 141.
- "Measuring Minimum/Maximum Power" on page 150.
- "Measuring Maximum RF Output Power" on page 154.
- "Measuring Minimum Controlled Output Power" on page 164.
- "Measuring the Range of Open Loop Output Power" on page 175.
- "Measuring Access Probe Output Power" on page 186.

Measuring Waveform Quality

The Test Set measures waveform quality using the correlated power method recommended in TIA/EIA IS-95. When a waveform quality measurement is made, the following measurements will be available:

- Rho (waveform quality)
- Frequency Error
- Phase Error
- Amplitude Error
- Time Offset
- Carrier Feedthrough

NOTE:

The following procedure assumes that an instrument PRESET will be performed as part of setting up a call. This clears all settings from other tests that may affect the accuracy of this test, and allows the procedure to begin from a known instrument state.

1. Make a Service Option 2 or 9 call

See "[Setting up a Call](#)" on [page 52](#) if you are not familiar with how this procedure is performed with the Test Set.

After setting up the call, return to this procedure.

2. Set the test parameter Traffic E_c/I_{or} .

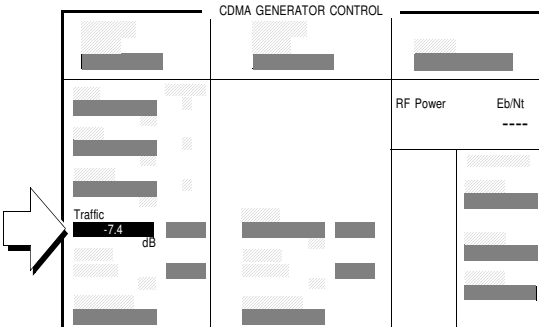
<p>Manual Operation:</p> <ol style="list-style-type: none">1. Press the CDMA SCRNS - GEN CTRL key to display the CDMA GENERATOR CONTROL screen.2. Position the cursor at the Traffic field.3. Set the Traffic E_c/I_{or} value with the DATA keys. Refer to the TIA/EIA IS-98 performance standards for recommended test parameters.4. Press the ENTER key or the knob to enter the value.	 <p><i>Values in this field are expressed in dB, relative to Sector A Power.</i></p>
---	--

HP-IB Syntax

"DISP CGEN;CDMA:CELL:ASEC:TRAF -7.4" ! Displays the CDMA GENERATOR CONTROL screen and sets the Traffic field to -7.4 dB.

3. Set the test parameter \hat{I}_{Or} .

Manual Operation:

1. Position the cursor at the Sector A Power field.
2. Set the value with the DATA keys. Refer to the TIA/EIA IS-98 performance standards for test parameters.
3. Press the ENTER key or the knob to enter the value.

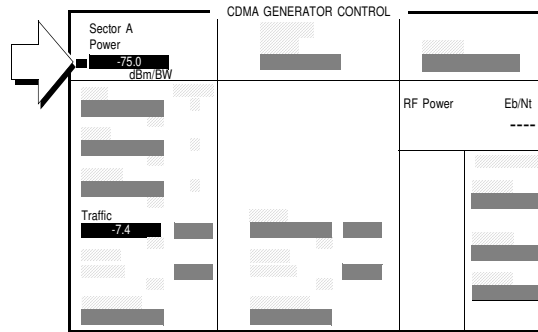

The value for Sector A Power is referred to as I_{Or} .

HP-IB Syntax

"CDMA:CELL:ASEC -75" ! Sets the Sector A power field to -75 dBm/BW

4. Arm a single measurement.

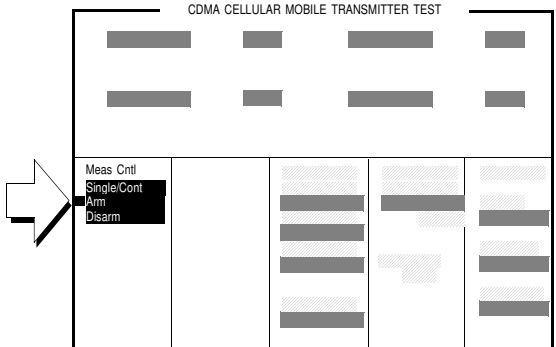
<p>Manual Operation:</p> <ol style="list-style-type: none">1. Press the CDMA SCRNS - TX TEST key to display the CDMA CELLULAR MOBILE TRANSMITTER TEST screen.2. Position the cursor at the Arm field.3. Press the knob to arm a measurement.	
<p><i>The default trigger mode is <u>Single</u> for local operation. If <u>Cont</u> is selected (local operation), the Arm and Disarm fields are removed from the display and measurements trigger continuously. If the Test Set is put in remote mode.</i></p> <p><i>The default trigger mode is Repetitive for remote operation. The HP-IB command shown below is used to set the trigger mode to single, which will remain in effect until the Test Set is returned to local operation.</i></p>	

HP-IB Syntax

"TRIG:MODE:RETR SING" !selects Single measurement mode.
"TRIG" ! Arms and triggers the waveform quality measurement.

5. Measure Rho.

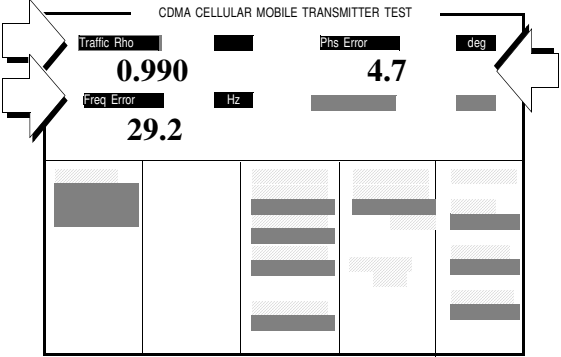
<p>Manual Operation:</p> <p>Read the Traffic Rho measurement, Frequency Error, and Phase Error on the front panel display.</p>	
<p><i>By selecting the Freq Error field shown in the figure above, Amplitude Error and Time Offset will be displayed in the list of Choices, in addition to Frequency Error. Any one of these measurements can be displayed in the Freq Error field by positioning the cursor next to it and pressing the knob.</i></p> <p><i>By selecting the Phs Error field shown in the figure above, Carrier (Feedthrough) will be displayed in the list of Choices in addition to Phs Error. Either one of these measurements can be displayed in the Phs Error field by positioning the cursor next to it and pressing the knob.</i></p>	

HP-IB Syntax

- "DISP CTXT;MEAS:CDM:RHO?" !queries the Rho measurement results
- "DISP CTXT;MEAS:CDM:FREQ:ERR?" !queries the Frequency Error measurement results
- "DISP CTXT;MEAS:CDM:AMPL:ERR?" !queries the Amplitude Error measurement results
- "DISP CTXT;MEAS:CDM:TIME:OFFS?" !queries the Time Offset measurement results
- "DISP CTXT;MEAS:CDM:PHAS:ERR?" !queries the Phase Error measurement results
- "DISP CTXT;MEAS:CDM:CAR:FEED?" !queries the Carrier Feedthrough measurement results

Measurement Overview

1. "Make a Service Option 2 or 9 call" on page 142.
See "Setting up a Call" on page 52.
2. "Set the test parameter Traffic Ec/Ior." on page 143.
Screen: CDMA GENERATOR CONTROL
Enter value in: **Traffic**.
3. "Set the test parameter Ior ." on page 144.
Screen: CDMA GENERATOR CONTROL
Enter value in: **Sector A Power**
4. "Arm a single measurement." on page 145.
Screen: CDMA CELLULAR MOBILE TRANSMITTER TEST
Start the measurement: **Meas Cntl, Arm**
5. "Measure Rho." on page 146.
Screen: CDMA CELLULAR MOBILE TRANSMITTER TEST
Observe: **Traffic Rho**

HPBASIC Program Example

The following programming example was developed using HPBASIC for Windows. It was tested on an HP 8924C with firmware rev A.02.26.

```
10 ! re-save "c:\hpbasic\TX_QUAL"
20 ! This program implements CDMA TX quality measurement.
30 ! This closely follows T33 from the 83217A Software.
40 CLEAR 714 !Clear interface
50 CLEAR SCREEN
60 OUTPUT 714;"CDMA:CALL:END" !End any previous call
70 WAIT .1
80 OUTPUT 714;"*RST"
90 WAIT 2
100 Page_phone
110 CLEAR SCREEN
120 Meas_tx_quality
130 DISP "PROGRAM DONE"
140 END
150 Meas_tx_quality: SUB Meas_tx_quality
160 DISP "Measuring Rho (Transmitted waveform quality) "
170 OUTPUT 714;"CDMA:CELL:ASEC -75"
180 OUTPUT 714;"CDMA:CELL:ASEC:PIL -7;TRAF -7.4"
190 OUTPUT 714;"TRIG:MODE:RETR SINGLE"
200 OUTPUT 714;"DISP CTXT"
210 OUTPUT 714;"TRIG:AST 'ARM' "
220 OUTPUT 714;"MEAS:CDM:RHO?"
230 ENTER 714;Rho
240 OUTPUT 714;"MEAS:CDM:FREQ:ERR?;ERR:UNIT?"
250 ENTER 714;Freq_err,Freq_unit$
260 PRINT Freq_err,Freq_unit$
270 OUTPUT 714;"MEAS:CDM:AMPL:ERR?"
280 ENTER 714;Ampl
290 OUTPUT 714;"MEAS:CDM:TIME:OFFS?"
300 ENTER 714;Time_off
310 OUTPUT 714;"MEAS:CDM:PHAS:ERR?"
320 ENTER 714;Phase_err
330 OUTPUT 714;"MEAS:CDM:CAR:FEED?"
```

```
340 ENTER 714;Carrier_feed
350 PRINT "Rho = ";Rho
360 PRINT "Frequency Err = ";Freq_err;Freq_unit$
370 PRINT "Amplitude Err = ";Ampl
380 PRINT "Time Offset Err = ";Time_off
390 PRINT "Phase Err = ";Phase_err
400 PRINT "Carrier Feedthrough = ";Carrier_feed
410 SUBEND
420 Page_phone: SUB Page_phone
430 OUTPUT 714;"CDMA:CELL:ASEC:BWP -50 dBm;STAT ON"
440 OUTPUT 714;"CDMA:RFCH 384"
450 PRINT "WHEN THE MOBILE FINDS SERVICE, PRESS THE"
455 PRINT "CONTINUE SOFTKEY (F2)"
460 DISP "Waiting..."
470 PAUSE
480 OUTPUT 714;"CDMA:CALL:TRAF:DATA:MODE 'SVC OPT 2'"
490 OUTPUT 714;"CDMA:CALL:MAKE"
500 DISP "Mobile is being paged..."
510 REPEAT
520 WAIT .1
530 OUTPUT 714;"STAT:CDMA:EVENT?"
540 ENTER 714;Event_reg
550 UNTIL BIT(Event_reg,3)! Monitoring "Connected" annunciator bit
560 CLEAR SCREEN
570 PRINT "Page successful, mobile is connected"
580 DISP "SO2 Call is connected:"
590 SUBEND
```

Measuring Minimum/Maximum Power

The Test Set provides a quick way to determine an MSUT's minimum power and maximum power using both open loop and closed loop power control. Two power measurements will be displayed at the end of this procedure, which takes several seconds to complete.

Test Prerequisites

- The Channel Power measurement should be calibrated at least as often as the following conditions arise:
 - 5 °C change in operating temperature
 - Power cycle
 - Daily

See "[Calibrating Channel Power Measurements](#)" on page 29 if necessary, and then return to this procedure. If the Channel Power measurement has been calibrated, zeroing the Average Power measurement is not necessary.

NOTE:

The following procedure assumes that an instrument PRESET will be performed as part of setting up a call. This clears all settings from other tests that may affect the accuracy of this test, and allows the procedure to begin from a known instrument state.

1. Set up a call

See "[Setting up a Call](#)" on page 52 if you are not familiar with how this procedure is performed with the Test Set.

After setting up the call, return to this procedure.

NOTE:

The RF path loss between the RF output of the Test Set and the RF input of the MSUT must be entered into the Test Set. Correcting for path loss by entering an RF level offset allows the Test Set analyzer's auto-ranging algorithm to work correctly throughout the operating range of the MSUT. Refer to "[Correct for RF Path Loss.](#)" on page 54.

2. Select the Min/Max Power field.

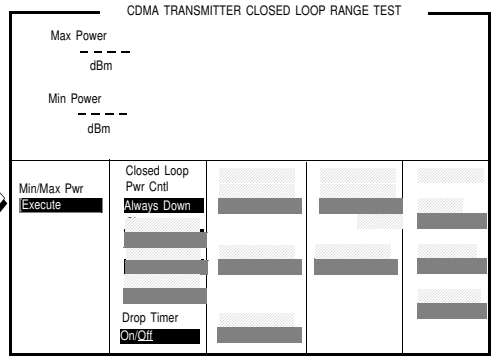
<p>Manual Operation:</p> <ol style="list-style-type: none">1. Press then release the blue SHIFT key, then press the RX TEST key to select the CDMA TRANSMITTER CLOSED LOOP RANGE TEST screen.2. Position the cursor at the Min/Max Pwr, Execute field.3. Press the knob to begin the Min/Max measurement.	
--	--

HP-IB Syntax

"MEAS:CDM:MMP" !executes the Min/Max power measurement

3. Measure Min/Max power.

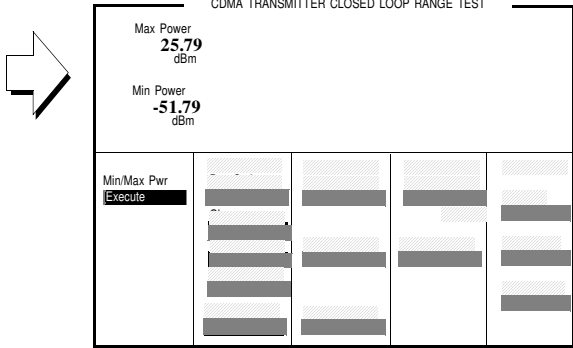
<p>Manual Operation:</p> <p>Read the Min Power and Max Power fields.</p>	
---	--

HP-IB Syntax

"CDMA:MOB:POW:MIN" !queries the last Min power value

"CDMA:MOB:POW:MAX" !queries the last Max power value

Measurement Overview

1. "Set up a call" on page 151.
See "Setting up a Call" on page 52.
2. "Select the Min/Max Power field." on page 152.
Screen: CDMA TRANSMITTER CLOSED LOOP RANGE TEST
3. "Measure Min/Max power." on page 153.
Screen: CDMA TRANSMITTER CLOSED LOOP RANGE TEST

Measuring Maximum RF Output Power

The Test Set measures mobile-station-under-test (MSUT) power using the average power meter. This test is performed according to TIA/EIA IS-98.

Test Prerequisites

- The Average Power measurement must be zeroed. Zeroing the average power measurement should be performed at least as often as the following conditions arise:
 - 5 °C change in operating temperature
 - Power cycle
 - Daily

See "[Zeroing Average Power Measurements](#)" on page 36 if necessary, and then return to this procedure.

NOTE:

The following procedure assumes that an instrument PRESET will be performed as part of setting up a call. This clears all settings from other tests that may affect the accuracy of this test, and allows the procedure to begin from a known instrument state.

1. Make a Service Option 2 call.

See "[Setting up a Call](#)" on page 52 if you are not familiar with how this procedure is performed with the Test Set.

After setting up the call, return to this procedure.

NOTE:

The RF path loss between the RF output of the Test Set and the RF input of the MSUT must be corrected. Correcting for path loss by entering an RF level offset allows the Test Set analyzer's auto-ranging algorithm to work correctly throughout the operating range of the MSUT. Refer to "[Correct for RF Path Loss.](#)" on page 54.

2. Enter the parameters for the Access Parameters message.

Manual Operation:

1. Press then release the blue SHIFT key, then press the CALL CTRL to select the CDMA CELL SITE CONFIGURATION screen.
2. Set the parameter values for the following fields:
Nom Power - 7
Init Power - 15
Power Step - 7
Num Step - 15
Max Req Seq/Max Rsp Seq - 15

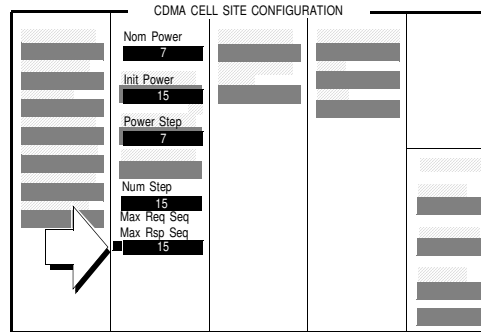

The parameters Nom Power and Init Power will cause an offset to the open loop estimate. When these values are entered, the Test Set will apply the offset by increasing the MSUT's power level through closed-loop power control.

This step can also be performed before the call is setup in step 1. Using this method, the parameters entered in these fields will be sent in the Access Parameters Message during call setup. Either method will result in the same power level output from the MSUT. If you select this method be aware that presetting the Test Set will return the parameters in the CDMA CELL SITE CONFIGURATION screen to their default values.

HP-IB Syntax

```
"DISP CCON" ! displays the CDMA CELL CONFIGURATION screen.  
"CDMA:CELL:CONF:NOM:POW 7" !sets the Nom Power field to 7.  
"CDMA:CELL:CONF:INIT:POW 15" !sets the Init Power field to 15.  
"CDMA:CELL:CONF:STEP:POW 7" !sets the Power Step field to 7.  
"CDMA:CELL:CONF:NUMS 15" !sets the Num Step field to 15.  
"CDMA:CELL:CONF:MAXR 15" !sets the Max Req Seq/Max Rsp Seq field to 15.
```

3. Set the test parameter Traffic E_c/I_{or} .

Manual Operation:

1. Press the CDMA SCRNS - GEN CTRL key to display the CDMA GENERATOR CONTROL screen.
2. Position the cursor at the Traffic field.
3. Set the Traffic E_c/I_{or} value with the DATA keys. Refer to the TIA/EIA IS-98 performance standards for recommended test parameters.
4. Press the ENTER key or the knob to enter the value.

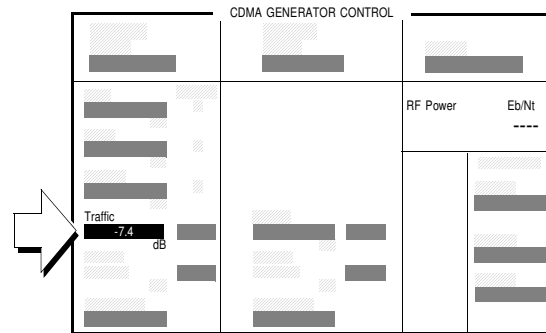

Values in this field are expressed in dB, relative to Sector A Power.

HP-IB Syntax

```
"DISP CGEN;CDMA:CELL:ASEC:TRAF -7.4"  
! displays the CDMA GENERATOR CONTROL screen  
! and sets Traffic  $E_c/I_{or}$  to -7.4 dB.
```

4. Set the test parameter I_{Or} .

Manual Operation:

1. Position the cursor at the Sector A Power field.
2. *Gradually* adjust power to the required value for this test using the Cursor Control knob. The call may drop if Sector A Power is lowered too abruptly.

Refer to the TIA/EIA IS-98 performance standards for test parameters.

The value for Sector A Power is referred to as I_{Or} .

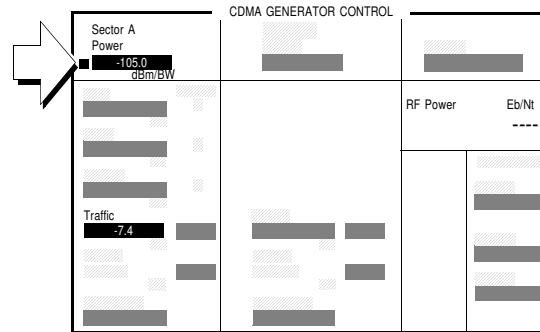

HP-IB Help

If the call drops, you may need to decrement power to -105 dBm/BW more gradually.

HP-IB Syntax

```
"CDMA:CELL:ASEC -105" !sets  $I_{Or}$  to -105 dBm/BW.
```

5. Send continuous '0' power control bits to increase MSUT power.

Manual Operation:

1. Press then release the blue SHIFT key, then press the RX TEST key to select the CDMA TRANSMITTER CLOSED LOOP RANGE TEST screen.
2. Position the cursor at the Closed Loop Pwr Control field and select Always Up.

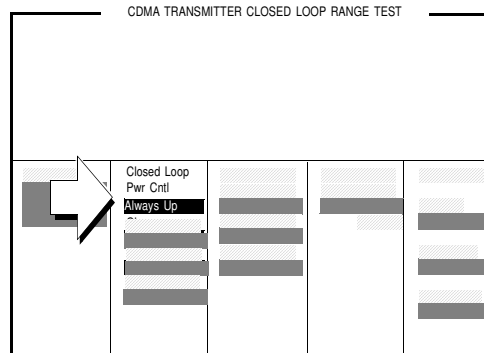

'0' power control bits increase the MSUT's output power.

HP-IB Syntax

"CDMA:PCON:MODE 'Always Up' " !selects continuous '0' power control bits.

6. Measure average power.

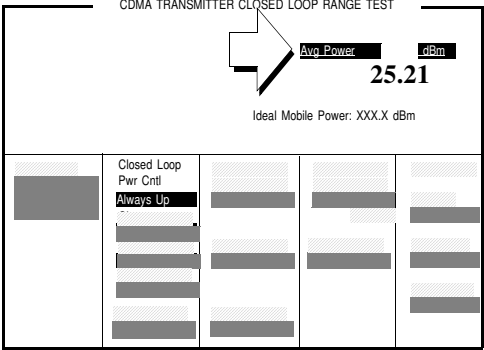
<p>Manual Operation:</p> <p>Read the average power measurement.</p>	
--	--

HP-IB Syntax

"MEAS:CDM:AVGP?" !queries the Average Power measurement.

Measurement Overview

1. "Make a Service Option 2 call." on page 155.

See "Setting up a Call" on page 52.

2. "Enter the parameters for the Access Parameters message." on page 156.

Screen: CDMA CELL SITE CONFIGURATION

Enter values in: **Nom Power**, **Init Power**, **Power Step**, **Num Step**,
Max Req Seq/Max Rsp Seq

3. "Set the test parameter Traffic Ec/Ior." on page 157.

Screen: CDMA GENERATOR CONTROL

Enter value in: **Traffic**.

4. "Set the test parameter Ior ." on page 158.

Screen: CDMA GENERATOR CONTROL

Enter value in: **Sector A Power**

5. "Send continuous '0' power control bits to increase MSUT power." on page 159.

Screen: CDMA TRANSMITTER CLOSED LOOP RANGE TEST

Enter value in: **Closed Loop Pwr Cntl**.

6. "Measure average power." on page 160.

Measure the average power.

Screen: CDMA CELLULAR MOBILE TRANSMITTER TEST

Observe: **Avg Power**

HPBASIC Programming Example

The following programming example was developed using HPBASIC for Windows. It was tested on an HP 8924C with firmware rev A.02.29.

```
10 ! re-save "c:\hpbasic\MAX_POW"
20 ! This program implements CDMA Max Output Power test.
30 ! This closely follows T36 from the 83217A Software.
40 !
50 Initialize_ts ! Initialize test set routine
60 Page_phone ! Requires the phone to have been previously registered
70 Max_output_pow ! Measure max power
80 OUTPUT 714;"CDMA:CALL:END"
90 DISP "PROGRAM DONE"
100 END
110 Max_output_pow: SUB Max_output_pow
120 CLEAR SCREEN
130 DISP "Measuring the mobiles' maximum output power..."
140 OUTPUT 714;"CDMA:TX:POW:MEAS 'Avg Power';:MEAS:CDM:AVG:STAT ON"
150 !The following 5 lines set up parameters that
160 !help drive the phone to its maximum power
170 OUTPUT 714;"CDMA:CELL:CONF:NOM:POW 7"
175 OUTPUT 714;"CDMA:CELL:CONF:INIT:POW 15"
180 OUTPUT 714;"CDMA:CELL:CONF:STEP:POW 7"
185 OUTPUT 714;"CDMA:CELL:CONF:NUMS 15"
185 OUTPUT 714;"CDMA:CELL:CONF:MAXR 15"
190 OUTPUT 714;"CDMA:CELL:ASEC:PIL -7dB;SYNC -16dB;PAG -12dB;TRAF -7.4dB"
200 OUTPUT 714;"MEAS:CDM:AVGP:UNITS DBM"
210 !Lower Ior to increase mobile power
220 ! Do this in short steps to prevent dropping a call. Also, the IS-98
230 ! specifies -104 dBm/BW, but most mobiles will output max power at
240 ! -90 dBm/BW. The test may be more reliable at -90 dBm/BW if the mobile
250 ! receiver has difficulty at -104 dBm/BW.
260 OUTPUT 714;"CDMA:CELL:ASEC:BWP -90 dBm"
270 WAIT .5
280 OUTPUT 714;"CDMA:CELL:ASEC:BWP -104 dBm"
290 WAIT .5
300 Select 'Always Up' to send a continues stream of 'Up' power control bits
```

```
310 OUTPUT 714;"CDMA:PCON:MODE 'Always Up' "  
320 WAIT 3 ! Give the phone a little time to get to max output.  
330 OUTPUT 714;"MEAS:CDM:AVGP?;AVGP:UNIT?" ! Measure while still sending up bits  
340 ENTER 714;Measured_val,Pwr_unit$  
350 PRINT "Maximum Output Power is ";PROUND(Measured_val,-1);Pwr_unit$  
360 SUBEND  
370 Page_phone: SUB Page_phone  
380 OUTPUT 714;"CDMA:CELL:ASEC:BWP -50 dBm;STAT ON"  
390 OUTPUT 714;"CDMA:RFCH 384"  
400 PRINT "WHEN THE MOBILE FINDS SERVICE, PRESS THE"  
405 PRINT "CONTINUE SOFTKEY (F2) "  
410 DISP "Waiting..."  
420 PAUSE  
430 OUTPUT 714;"CDMA:CALL:TRAF:DATA:MODE 'SVC OPT 2' "  
440 OUTPUT 714;"CDMA:CALL:MAKE"  
450 CLEAR SCREEN  
460 DISP "Mobile is being paged..."  
470 REPEAT  
480 WAIT .1 !100 mS wait to allow Test Set to handle other tasks  
490 OUTPUT 714;"STAT:CDMA:EVENT?"  
500 ENTER 714;Event_reg  
510 UNTIL BIT(Event_reg,3)! Monitoring "Connected" annunciator bit  
520 CLEAR SCREEN  
530 PRINT "Page successful, mobile is connected"  
540 SUBEND  
550 Initialize_ts: SUB Initialize_ts  
560 CLEAR 714  
570 CLEAR SCREEN  
580 DISP "Initializing...."  
590 OUTPUT 714;"*RST"! Reset  
600 WAIT 3  
610 OUTPUT 714;"*CLS" ! Clear event status registers  
620 OUTPUT 714;"CONF:OFL:MODE 'ON';RFIN -2"! External Path Loss  
630 SUBEND
```

Measuring Minimum Controlled Output Power

The Test Set measures the mobile-station-under-test (MSUT) power level using calibrated Channel Power measurements. The Test Set performs this test as described in IS-98.

Test Prerequisites

- The Channel Power measurement should be calibrated at least as often as the following conditions arise:
 - 5 °C change in operating temperature
 - Power cycle
 - Daily

See "[Calibrating Channel Power Measurements](#)" on page 29 if necessary, and then return to this procedure.

NOTE:

The following procedure assumes that an instrument PRESET will be performed as part of setting up a call. This clears all settings from other tests that may affect the accuracy of this test, and allows the procedure to begin from a known instrument state.

1. Set up a Service Option 2 call.

See "[Setting up a Call](#)" on page 52 if you are not familiar with how this procedure is performed with the Test Set.

After setting up the call, return to this procedure.

NOTE:

The RF path loss between the RF output of the Test Set and the RF input of the MSUT must be corrected for. Correcting for path loss by entering an RF level offset allows the Test Set analyzer's auto-ranging algorithm to work correctly throughout the operating range of the MSUT. See "[Correct for RF Path Loss.](#)" on page 54

2. Set the test parameter Traffic E_c/I_{or} .

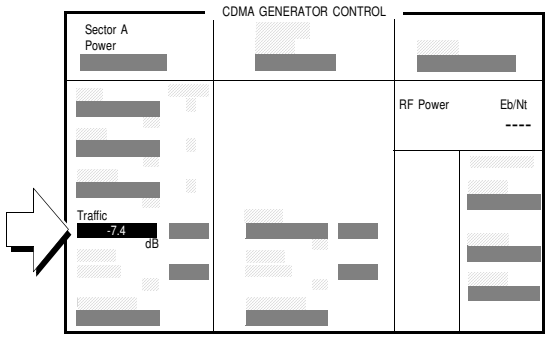
<p>Manual Operation:</p> <ol style="list-style-type: none">1. Press the CDMA SCRNS - GEN CTRL key to display the CDMA GENERATOR CONTROL screen.2. Position the cursor at the Traffic field.3. Set the Traffic E_c/I_{or} value with the DATA keys. Refer to the TIA/EIA IS-98 performance standards for recommended test parameters.4. Press the ENTER key or the knob to enter the value.	
<p><i>Values in this field are expressed in dB, relative to Sector A Power.</i></p>	

HP-IB Syntax

"DISP CGEN;CDMA:CELL:ASEC:TRAF -7.4" ! Sets the Sector A Power field to -7.4 dB.

3. Set the test parameter \hat{I}_{Or} .

Manual Operation:

1. Position the cursor at the Sector A Power field.
2. Set the value with the DATA keys. Refer to the TIA/EIA IS-98 performance standards for test parameters.
3. Press the ENTER key or the knob to select the value.

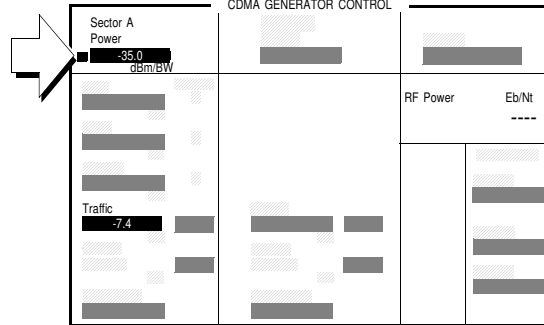

The value for Sector A Power is referred to as I_{Or} .

HP-IB Syntax

```
"CDMA:CELL:ASEC -35" !sets Sector A  $I_{Or}$  to -35 dBm/BW.
```

4. Disable the Call Drop timer.

Manual Operation:

1. Press then release the blue SHIFT key, then press the RX TEST key to select the CDMA TRANSMITTER CLOSED LOOP RANGE TEST screen.
2. Position the cursor at the Drop Timer field.
3. Press the knob to underline the word "Off".

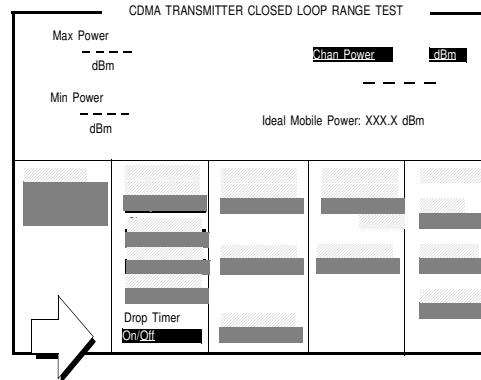

Selecting "Off" causes the Test Set to ignore missed frames, which are likely to occur at the low power levels the MSUT will be outputting during this test. When the Call Drop timer is "On", the Test Set ends the call any time a continuous sequence of 256 sequential frames is missed.

HP-IB Syntax

"CDMA:CALL:DTIMER 'Off' " ! Disables the call drop timer off

5. Send continuous "1" power control bits to decrease MSUT power.

Manual Operation:

Position the cursor at the Closed Loop Pwr Control field and select Always Down.

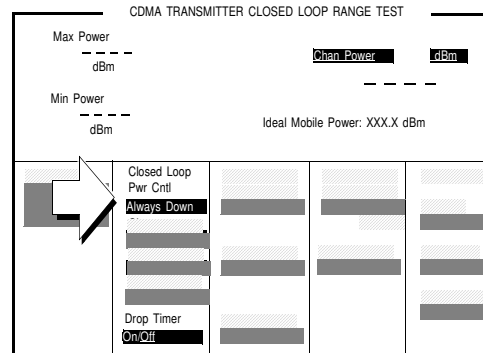

'1' power control bits decrease the MSUT's output power.

HP-IB Syntax

"CDMA:PCON:MODE 'Always Down'" !selects continuous '1' power control bits.

6. Measure channel power.

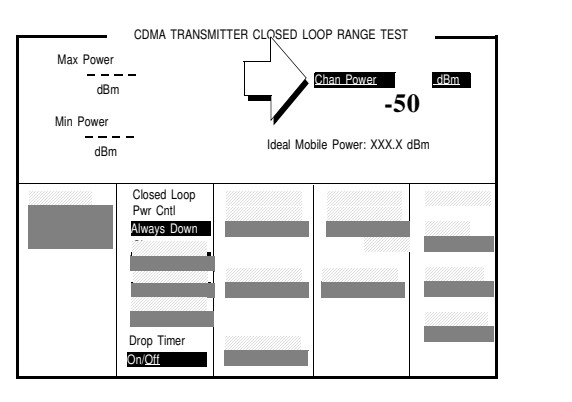
<p>Manual Operation:</p> <ol style="list-style-type: none">1. Position the cursor in front of the field shown and select Chan Power.2. Read the channel power measurement.	
--	--

HP-IB Syntax

"CDMA:TX:POW:MEAS 'Chan Power'" selects the Channel Power measurement.

"MEAS:CDM:CHAN?" !queries the Channel Power measurement.

Measurement Overview

1. "Set up a Service Option 2 call." on page 165.
See "Setting up a Call" on page 52.
2. "Set the test parameter Traffic Ec/Ior." on page 166.
Screen: CDMA GENERATOR CONTROL
Enter value in: **Traffic**.
3. "Set the test parameter Ior ." on page 167.
Screen: CDMA GENERATOR CONTROL
Enter value in: **Sector A Power**
4. "Disable the Call Drop timer." on page 168.
Screen: CDMA CLOSED LOOP RANGE TEST
Make selection in: **Drop Timer**
5. "Send continuous "1" power control bits to decrease MSUT power." on page 169.
Screen: CDMA GENERATOR CONTROL
Enter value in: **Sector A Power**
6. "Measure channel power." on page 170.
Screen: CDMA CELLULAR MOBILE TRANSMITTER TEST
Observe: **Chan Power**

HPBASIC Programming Example

The following programming example was developed using HPBASIC for Windows. It was tested on an HP 8924C with firmware rev A.02.26.

```
10 ! re-save "c:\8924c\ex_progs\min_pwr.txt"
20 ! This program implements CDMA Minimum Power test.
30 ! This closely follows T37 from the 83217A Software.
40 ON TIMEOUT 7,5 GOTO End_of_program
50 Prot$="'J-STD-008'" !Enter mobile's protocol stack
60 Rfcs$="'KOR PCS P0'" !Enter mobile's RF channel standard
70 Rfch=525 !Enter mobile's primary CDMA RF Channel number
80 Sid$="2222"
90 Mcc$="241"
100 Mnc$="10"
110 Initialize_ts(Rfch,Prot$,Rfcs$,Sid$,Mcc$,Mnc$)!Preset and initialize test set
120 Reg_phone! Register the phone (Power-up registration must be off)
130 Page_phone ! Require mobile to have been previously registered
140 Min_pow ! Measure minimum output power
150 STOP
160 OUTPUT 714;"CDMA:CALL:END" ! Release the call
170 DISP "PROGRAM DONE"
180 End_of_program: !A timeout on the HP-IB will cause the program to branch here
190 END
200 Page_phone: SUB Page_phone
210 OUTPUT 714;"CDMA:CALL:TRAF:DATA:MODE 'SVC OPT 2'"
220 DISP "Mobile is being paged..."
240 REPEAT
250 WAIT .1 !100 mS wait to allow Test Set to handle other tasks
260 OUTPUT 714;"STAT:CDMA:EVENT?"
270 ENTER 714;Event_reg
280 UNTIL BIT(Event_reg,3)! Monitoring "Connected" annunciator bit
290 DISP ""
300 PRINT "Page successful, mobile is connected"
310 SUBEND
320 Min_pow: SUB Min_pow
330 DISP "Measuring Minimum Power ...."
340 OUTPUT 714;"CDMA:CELL:ASEC:BWP -25" ! Sector A power
```

```
350 OUTPUT 714;"CDMA:CELL:ASEC:TRAF -7.4" ! Sector A traffic level
360 WAIT .3
370 OUTPUT 714;"CDMA:CALL:DTIMER 'Off'" ! Disable drop timer
380 OUTPUT 714;"CDMA:PCON:MODE 'Always Down'" ! Send all Down'power control bits
390 OUTPUT 714;"CDMA:TX:POW:MEAS 'Chan Power'" ! Select Channel Power Measurement
400 OUTPUT 714;"MEAS:CDM:CHAN:UNITS DBM;STAT ON"
410 WAIT 2! Give the phone a little time to get settled at Minimum Power
420 OUTPUT 714;"MEAS:CDM:CHAN?"
430 ENTER 714;Mv
440 PRINT ""
450 PRINT "Minimum Power is ";PROUND(Mv,-1);" dB"
460 !Return the Test Set to Closed Loop Power Control Mode
470 OUTPUT 714;"CDMA:PCON:MODE 'Closed Loop'"
480 PRINT
490 SUBEND
500 Initialize_ts: SUB Initialize_ts(Rfch,Prot$,Rfcs$,Sid$,Mcc$,Mnc$)
510 CLEAR 714 ! Clear the HP-IB
520 CLEAR SCREEN
530 DISP "Initializing...."
540 OUTPUT 714;"*RST"! Reset
550 WAIT 5
560 OUTPUT 714;"*CLS" ! Clear event status registers
570 OUTPUT 714;"CONF:OFL:MODE 'ON';RFIN -2"! External Path Loss
580 OUTPUT 714;"CDMA:CELL:CONF:PUR 'Off'" !Turn off Power Up
Registration field
590 OUTPUT 714;"CDMA:CELL:ASEC:BWP -25 dBm;STAT ON" !Sector A
power setting
600 OUTPUT 714;"CDMA:CELL:PROT ";Prot$ !Protocol stack
610 OUTPUT 714;"CONF:RFCS ";Rfcs$ !Rf channel standard
620 OUTPUT 714;"CDMA:CELL:CONF:SID ";Sid$
630 OUTPUT 714;"CDMA:CELL:CONF:BCC ";Mcc$
640 OUTPUT 714;"CDMA:CELL:CONF:BNC ";Mnc$
650 OUTPUT 714;"CDMA:RFCH ";Rfch ! RF channel
660 DISP "waiting for service"
670 PAUSE
680 SUBEND
690 Reg_phone: SUB Reg_phone
```

Chapter 4, CDMA Transmitter Tests

Measuring Minimum Controlled Output Power

```
700 OUTPUT 714;"CDMA:MOB:REG" !Initiate a zone-based
      registration
710 DISP "Test Set is registering the phone..."
720 T=TIMEDATE
730 REPEAT
740 OUTPUT 714;"STAT:CDMA:EVEN?"    !Query the CDMA Status
      Event Register
750 ENTER 714;Reg
760 IF TIMEDATE-T>25 THEN
770 DISP "Registration error, program stopped"
780 STOP
790 ELSE
800   WAIT .1 !Mandatory 100 ms wait to allow other Test Set processes
810 END IF
820 UNTIL BIT(Reg,11)    !Bit 11 is the "Registered" bit
830 DISP ""
840 PRINT "Registration successful"
850 WAIT .2 !Wait for phone to prepare for page
860 SUBEND
```

Measuring the Range of Open Loop Output Power

The Test Set measures the range over which the mobile-station-under-test (MSUT) can adjust its Effective Radiated Power (ERP) in response to the power level it receives from the Test Set. This test is performed according to TIA IS-98 standards, except that \hat{I}_{or} is set to -35 dBm/BW instead of the recommended value of -25 dBm/BW for the first test.

Test Prerequisites

- The Channel Power measurement should be calibrated at least as often as the following conditions arise:
 - 5 °C change in operating temperature
 - Power cycle
 - Daily

See "[Calibrating Channel Power Measurements](#)" on page 29 if necessary, and then return to this procedure.

NOTE:

The following procedure assumes that an instrument PRESET will be performed as part of setting up a call. This clears all settings from other tests that may affect the accuracy of this test, and allows the procedure to begin from a known instrument state.

1. Make a Service Option 2 call.

See "[Setting up a Call](#)" on page 52 if you are not familiar with how this procedure is performed with the Test Set.

After setting up the call, return to this procedure.

NOTE:

The RF path loss between the RF output of the Test Set and the RF input of the MSUT must be corrected for. Correcting for path loss by entering an RF level offset allows the Test Set analyzer's auto-ranging algorithm to work correctly throughout the operating range of the MSUT. See "[Correct for RF Path Loss.](#)" on page 54

2. Set the test parameter Traffic E_c/I_{or} .

Manual Operation:

1. Press the GEN CTRL key to display the CDMA GENERATOR CONTROL screen.
2. Position the cursor at the Traffic field.
3. Set the value with the DATA keys. Refer to the TIA/EIA IS-98 performance standards for test parameters.
3. Press the ENTER key or the knob to select the value.

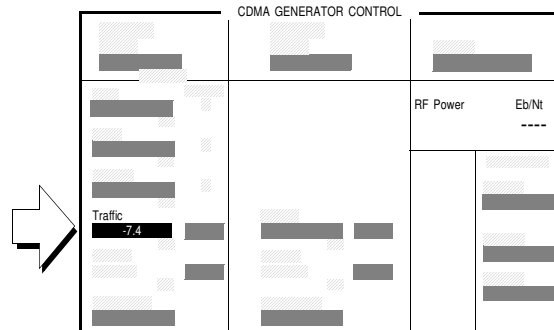

HP-IB Syntax

"CDMA:CELL:ASEC:TRAF -7.4" !sets Traffic E_c/I_{or} to -7.4 dB.

3. Select Open Loop power control.

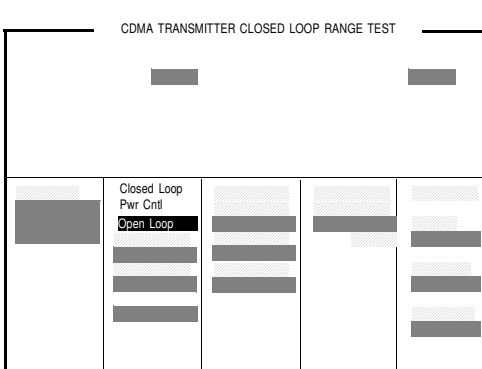
<p>Manual Operation:</p> <ol style="list-style-type: none">1. Press and release the SHIFT key, then press the CDMA SCRNS - RX TEST key to display the CDMA TRANSMITTER CLOSED LOOP RANGE TEST screen.2. Position the cursor at the Closed Loop Pwr Cntl field and press the knob to display the Choices menu.3. Select Open Loop from the list of choices.	
<p><i>When Open Loop is selected, the Test Set sends alternating power control bits on the Forward Traffic Channel.</i></p>	

HP-IB Syntax

"DISP CTXR" !displays the CDMA TRANSMITTER CLOSED LOOP RANGE TEST screen.

"CDMA:PCON:MODE 'Open Loop'" !selects Closed Loop power control mode.

4. Set the test parameter \hat{I}_{or} .

Manual Operation:

1. Press the TX TEST key to display the CDMA CELLULAR MOBILE TRANSMITTER TEST screen.
2. Position the cursor next to the field shown in the figure.
3. Set the value by slowly turning the knob or use the INCR SET key along with the UP/DOWN arrow keys to *gradually* adjust \hat{I}_{or} . Refer to the TIA/EIA IS-98 performance standards for test parameters.

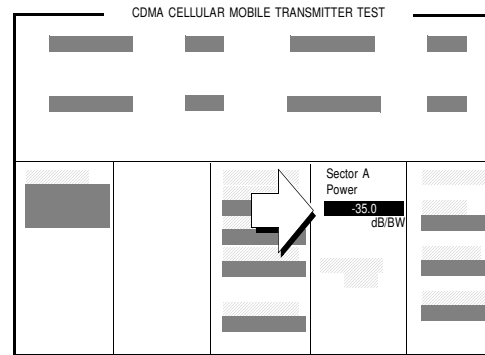

The value for Sector A Power is referred to as I_{or}

HP-IB Syntax

"CDMA:CELL:A SEC -35" Sets the Sector A Power field to -35 dBm/BW.

5. Measure the MSUT's power level.

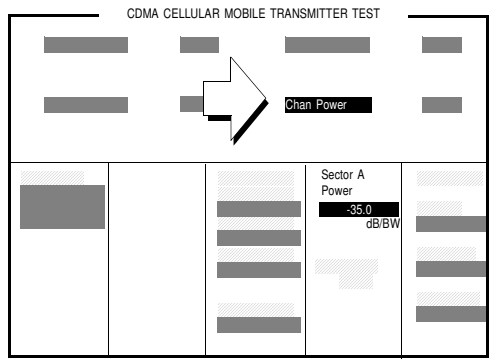
<p>Manual Operation:</p> <ol style="list-style-type: none">1. Position the cursor next to the field shown in the figure.3. Press the knob to display the Choices menu.4. Select Chan Power from the list of choices. (See ranges, below).5. Read the power level.	
<p><i>Channel Power measurement range = -50 to +35 dBm/1.23 MHz BW.</i></p> <p><i>Note: If Sector A Power is set to a high level, such as -25 dBm, and an Average Power measurement is made, the Test Set will display a measurement value that is higher than you would expect from the MSUT. This measurement result is an artifact of the Test Set's broad band power meter, and does not affect Channel Power measurements, which must be used when the MSUT power level is below -10 dBm/1.23 MHz BW.</i></p>	

HP-IB Syntax

```
"CDMA:TX:POW:MEAS 'Chan Power' "  
!selects the Channel Power measurement.
```

```
"MEAS:CDM:CHAN?" !queries the channel power measurement.
```

6. Change the parameter \hat{I}_{or} , and measure power again.

Manual Operation:

1. Position the cursor next to the Sector A Power field as shown in the figure.
2. Gradually adjust the field to new value of \hat{I}_{or} . Refer to the TIA/EIA IS-98 performance standards for test parameters.

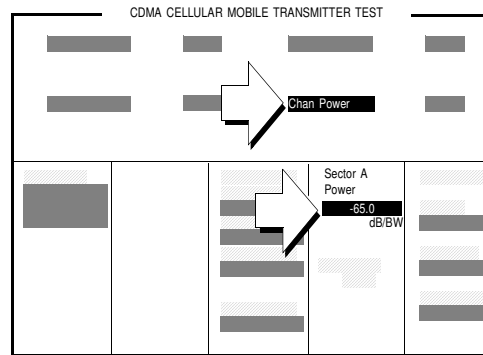

HP-IB Syntax

"CDMA:CELL:ASEC -65" Sets the Sector A Power field to -65 dBm/BW.

"MEAS:CDM:CHAN?" !queries the average power measurement.

7. Change the parameter \hat{I}_{or} , and measure power again.

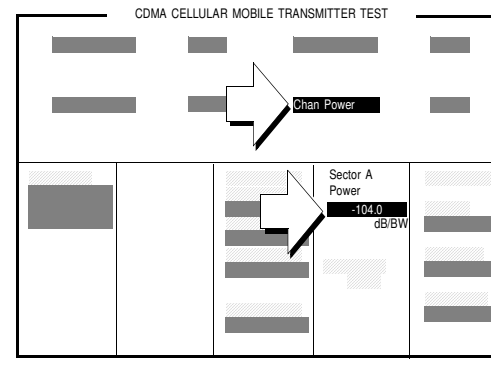
<p>Manual Operation:</p> <ol style="list-style-type: none">1. Position the cursor next to the Sector A Power field as shown in the figure.2. Gradually adjust the field to new value of \hat{I}_{or}. Refer to the TIA/EIA IS-98 performance standards for test parameters.	 <p>The screenshot displays a test interface titled "CDMA CELLULAR MOBILE TRANSMITTER TEST". It is divided into two main horizontal sections. The upper section shows a "Chan Power" field with a cursor pointing to it. The lower section shows a "Sector A Power" field with a value of "-104.0 dB/BW" and a cursor pointing to it. The interface includes various graphical elements like bars and a grid.</p>
--	---

HP-IB Syntax

"CDMA:CELL:ASEC -104" Sets the Sector A Power field to -104 dBm/BW.

"MEAS:CDM:CHAN?" !queries the average power measurement.

Measurement Overview

1. "Make a Service Option 2 call." on page 176.
See "Setting up a Call" on page 52.
2. "Set the test parameter Traffic Ec/Ior ." on page 177.
Screen: CDMA GENERATOR CONTROL
Enter value in: **Traffic**
3. "Select Open Loop power control." on page 178.
Screen: CDMA TRANSMITTER POWER RANGE TEST
Enter choice in: **Closed Loop Pwr Cntl.**
4. "Set the test parameter \hat{I}_{or} ." on page 179.
Screen: CDMA CELLULAR MOBILE TRANSMITTER TEST
Enter value in: **Sector A Power**
5. "Measure the MSUT's power level." on page 180.
Screen: CDMA CELLULAR MOBILE TRANSMITTER TEST
Observe: **Chan Power**
6. "Change the parameter \hat{I}_{or} , and measure power again." on page 181.
Screen: CDMA CELLULAR MOBILE TRANSMITTER TEST
Observe: **Chan Power** or **Avg Power**
7. "Change the parameter \hat{I}_{or} , and measure power again." on page 182.
Screen: CDMA CELLULAR MOBILE TRANSMITTER TEST
Observe: **Chan Power** or **Avg Power**

HPBASIC Programming Example

The following programming example was developed using HPBASIC for Windows. It was tested on an HP 8924C with firmware rev A.02.26.

```
10 ! re-store "c:\hpbasic\setrain\OPEN_RNG"
20 ! This program implements CDMA Open Loop Range test.
30 ! This closely follows T34 from the 83217A Software.
40 CLEAR SCREEN
50 OUTPUT 714;"*CLS"
60 OUTPUT 714;"CDMA:CALL:END"
70 WAIT 1
80 OUTPUT 714;"*RST" ! Good reset technique
90 WAIT 3
100 Page_phone
110 Open_loop_range
120 DISP "PROGRAM DONE"
130 END
140 Open_loop_range: SUB Open_loop_range
150 CLEAR SCREEN
160 DISP "TESTING OPEN LOOP RANGE"
170 OUTPUT 714;"CDMA:CELL:ASEC:BWP -25 dBm"
180 OUTPUT 714;"CDMA:PCON:MODE 'Open Loop' "
190 OUTPUT 714;"MEAS:CDM:CHAN:STAT ON"
195 OUTPUT 714;"MEAS:CDM:AVGP:STAT ON"
200 OUTPUT 714;"CDMA:TX:POW:MEAS 'Chan Power' "210 OUTPUT 714;"MEAS:CDM:CHAN:UNIT
DBM"
220 OUTPUT 714;"MEAS:CDM:AVGP:UNIT DBM"
220 !The following code tests mobile at -25, -65, and -105 dBm
230 FOR I=-25 TO -105 STEP -5
240 OUTPUT 714;"CDMA:CELL:ASEC:BWP "&VAL$(I)&" dBm"
250 WAIT 1 ! Let mobile settle
260 SELECT I
270 CASE -25,-65
280 OUTPUT 714;"MEAS:CDM:CHAN?"
290 ENTER 714;Measured_val
300 PRINT "Measured Power at ";VAL$(I)&" dbm = ";Measured_val;" dBm"
310 CASE -105
```



```
320 OUTPUT 714;"CDMA:TX:POW:MEAS 'Avg Power' "  
330 OUTPUT 714;"MEAS:CDM:AVGP?"  
340 ENTER 714;Measured_val  
350 PRINT "Measured Power at ";VAL$(I)&" dbm = ";Measured_val;" dBm"  
360 END SELECT  
370 NEXT I  
380 OUTPUT 714;"CDMA:CELL:ASEC:BWP -60" !So call doesn't drop  
390 OUTPUT 714;"CDMA:PCON:MODE 'CLOSED LOOP' "  
400 SUBEND  
410 Page_phone: SUB Page_phone  
420 OUTPUT 714;"CDMA:CELL:ASEC:BWP -50 dBm;STAT ON"  
430 OUTPUT 714;"CDMA:RFCH 384"  
440 PRINT "WHEN THE MOBILE FINDS SERVICE, PRESS CONTINUE (F2) "  
450 DISP "Waiting..."  
460 PAUSE  
470 OUTPUT 714;"CDMA:CALL:TRAF:DATA:MODE 'SVC OPT 2' "  
480 OUTPUT 714;"CDMA:CALL:MAKE"  
490 DISP "Mobile is being paged..."  
500 REPEAT  
510 WAIT .1 !100 mS wait to allow Test Set to handle other tasks  
520 OUTPUT 714;"STAT:CDMA:EVENT?"  
530 ENTER 714;Event_reg  
540 UNTIL BIT(Event_reg,3)! Monitoring "Connected" annunciator bit  
550 CLEAR SCREEN  
560 PRINT "Page successful, mobile is connected"  
570 SUBEND
```

Measuring Access Probe Output Power

NOTE:

The Test Set can measure access probe power without the need for following this procedure if the firmware revision is A.06.00 or above. Refer to the *HP 8924C Reference Guide*, Fields chapter, Acc Prb Pwr field description.

The Test Set provides call setup for this test, while the HP 859XE displays the access probes transmitted by the mobile-station-under-test (MSUT) and measures RF Power. The Test Set is put in a mode that limits the progression of call processing states, allowing the MSUT to transmit the maximum number of access probe sequences.

Test Prerequisites

Determine Cable Path Loss

When using cables to connect the equipment, the path loss for the cable(s) should be determined. The Test Set can be used as a source to measure path loss.

Refer to "[Correcting for RF Path Loss](#)" on page 41 if necessary, and then return to this procedure.

Recommended Equipment

Spectrum Analyzer

HP 895XE

Combiner

1. Connect the test instruments as shown.

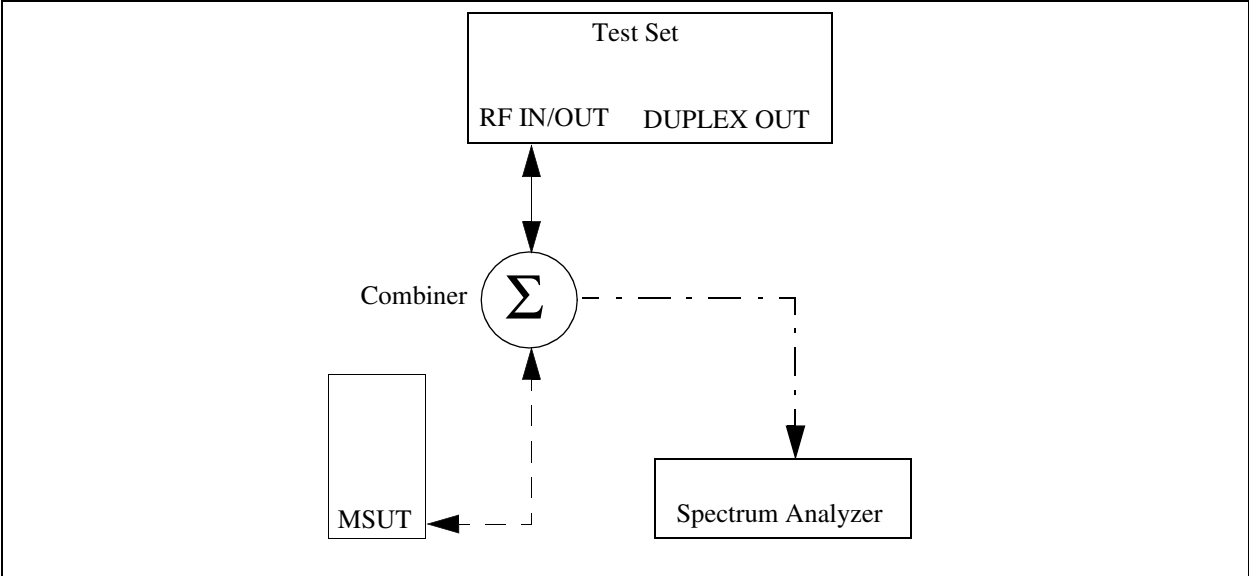

2. Set the test parameter \hat{I}_{Or} .

Manual Operation:

1. Press the CALL CTRL key to display the CDMA CALL CONTROL screen.
2. Position the cursor at the Sector A Power field.
3. Set the value with the DATA keys. Refer to the TIA/EIA IS-98 performance standards for test parameters.
4. Press the ENTER key or the knob to enter the value.

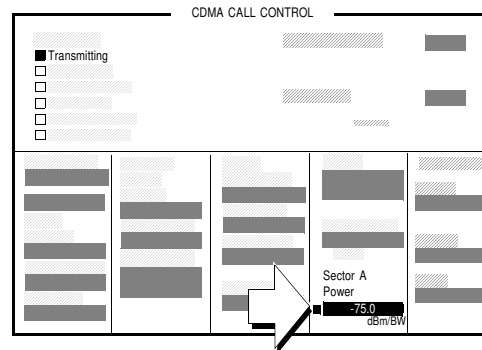

The value for Sector A Power is referred to as I_{Or} .

HP-IB Syntax

"DISP CCNT" !displays the CDMA CALL CONTROL screen.

"CDMA:CELL:ASEC -75" !sets I_{Or} to -75 dBm/BW.

3. Set the Test Set to ignore all access attempts.

Manual Operation:

1. Position the cursor at the Call Limit field.
2. Press the knob to toggle the selection to Page.

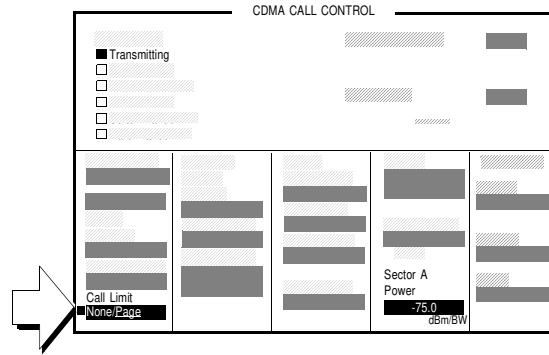

Selecting Page in the Call Limit field will allow the MSUT to transmit all of the access probe sequences according to test requirements in TIA/EIA IS-98.

HP-IB Syntax

```
"CDMA:CALL:LIM 'Page' "  
!sets the Test Set to not complete the call when the MSUT transmits  
!access probes.
```

4. Register the MSUT.

Manual Operation:

1. Position the cursor at the Register field.
2. Push the knob to select the field.
3. Watch for the Registering annunciator to go out and the MS Database field selection to be displayed or updated. Optional: Select *Clr All* in the MS Database list of choices to remove any data from previous registrations.

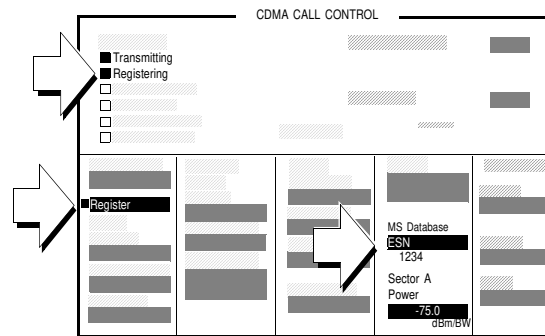

During registration, the Test Set acquires the MSUT's Phone Number and MIN (mobile identification). These numbers are required to make a call from the Test Set. An alternative method for the Test Set to acquire Phone Number and MIN is through the MS ID field on the CDMA Call Control screen. Refer to the "MS ID" field description in the Fields chapter of the HP 8924C Reference Guide.

The Registering annunciator will light when the Register field is selected, and go out when registration has completed successfully or timed out. If the message "Time-out occurred while attempting to register mobile" is displayed, refer to "Checklist 2. Registration failed" on page 70.

When the Register field is selected, values entered in the CDMA Cell Site Configuration screen's Rgstr SID and Rgstr NID (System ID and Network ID) fields are sent to the MSUT in a message called the System Parameters message. This SID/NID pair causes the MSUT to perform a "zone-based" registration. The Rgstr SID and Rgstr NID fields are set by default to 12. These values do not need to be changed unless the MSUT does not recognize them as valid, or the MSUT recognizes them as its home SID/NID. If either of these conditions exist, change Rgstr SID and Rgstr NID to arbitrary values that are both valid for the MSUT and do not match the MSUT's home SID/NID.

HP-IB Help

The **Registering** annunciator is assigned to bit 11 in the CDMA Status Register Group. The following program example polls the CDMA Status Event Register until bit 11, Mobile Station Registered, goes true.

HP-IB Syntax

DISP CCNT;CDMA:MOB:REG !Causes the mobile station to register.

HP BASIC Example

```

10 PRINT "PRESS CONTINUE WHEN THE MOBILE STATION IS IN IDLE STATE"
15 OUTPUT 714;"*CLS" !Clears contents of event registers
20 PAUSE
30 OUTPUT 714;"CDMA:MOB:REG" !Attempts to register mobile station
40 DISP "Registering mobile station"
50 REPEAT
60 WAIT .1 !Allows the Test Set to perform processes other than processing HP-IB commands
70 OUTPUT 714;"STAT:CDMA:EVEN?" !Queries the CDMA Event register
80 ENTER 714;Cdma_event_reg
90 UNTIL BIT(Cdma_event_reg,11) !Exits loop when Mobile Station Registered bit goes true
100 PRINT "MOBILE STATION HAS REGISTERED"
110 END
    
```

5. Set MAX_RSP_SEQ to 1.

Manual Operation:

1. Press and release the SHIFT key and then press the CALL CTRL key to display the CDMA CELL SITE CONFIGURATION screen.
2. Position the cursor at the Max Req Seq Max Rsp Seq field.
3. Use the knob to increment or decrement the value to 1.

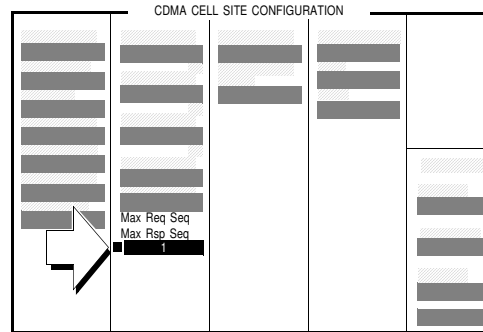

HP-IB Syntax

"DISP CCNF" !displays the CELL SITE CONFIGURATION screen"

"CDMA:CELL:CONF:MAXR 1"

6. Measure access probe power.

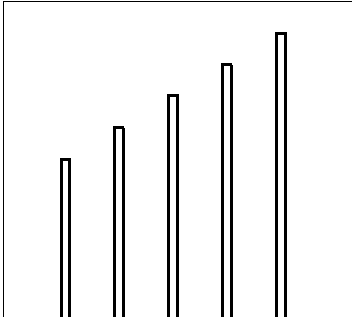
<p>Manual Operation:</p> <p>1. Press the CALL key on the Test Set's front panel to page the MSUT.</p> <p>Nominal settings for the Spectrum Analyzer are shown.</p>	<p>Spectrum Analyzer:</p> <p>Sweep Time: 5 s</p> <p>Ref: -15.0 dBm</p> <p>1 dB/Div</p> <p>Span: 0 Hz</p>	
<p><i>The figure above shows one access probe sequence, consisting of five access probes.</i></p> <p><i>After the CALL key is pressed on the Test Set, the Page Sent annunciator will light to indicate that a paging message was sent to the MSUT.</i></p> <p><i>The Access Probe annunciator will light to indicate that the mobile station has transmitted at least one access probe sequence in an attempt to gain system access.</i></p>		

HP-IB Syntax

"CDMA:CALL:MAKE" !pages the MSUT

7. Change the access parameters message.

Manual Operation:

1. Press then release the blue SHIFT key, then press the CALL CTRL to select the CDMA CELL SITE CONFIGURATION screen.
2. Set the values for the following fields:
 - Nom Power: 3
 - Init Power: 3
 - Power Step: 1
 - Num Step: 4
 - Max Rsp Seq: 3

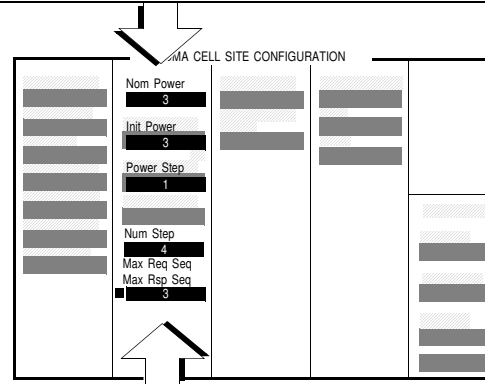

HP-IB Syntax

"DISP CCON" ! displays the CDMA CELL CONFIGURATION screen.

"CDMA:CELL:CONF:NOM:POW 3" !sets the Nom Power field to 3.

"CDMA:CELL:CONF:INIT:POW 3" !sets the Init Power field to 3.

"CDMA:CELL:CONF:STEP:POW 1" !sets the Power Step field to 1.

"CDMA:CELL:CONF:NUMS 4" !sets the Num Step field to 4.

"CDMA:CELL:CONF:MAXR 3" !sets the Max Rsp Seq field to 3.

8. Measure access probe power.

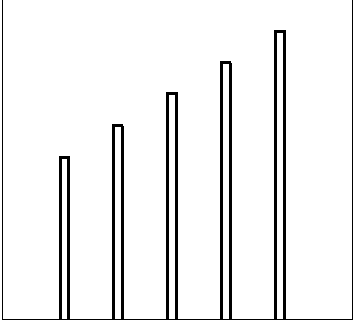
<p>Manual Operation:</p> <p>Press the CALL key on the Test Set's front panel to page the MSUT.</p> <p>Nominal settings for the Spectrum Analyzer are shown.</p>	<p>Spectrum Analyzer:</p> <p>Sweep Time: 5 s</p> <p>Ref: -15.0 dBm</p> <p>1 dB/Div</p> <p>Span: 0 Hz</p>	
<p><i>The figure above shows one access probe sequence, consisting of five access probes. In this test, the MSUT will transmit three access probe sequences.</i></p>		
<p><i>After the CALL key is pressed on the Test Set, the Page Sent annunciator will light to indicate that a paging message was sent to the MSUT.</i></p>		
<p><i>The Access Probe annunciator will light to indicate that the mobile station has transmitted at least one access probe sequence in an attempt to gain system access.</i></p>		

HP-IB Syntax

"CDMA:CALL:MAKE" !pages the MSUT

Measurement Overview

1. "Connect the test instruments as shown." on page 187.
Connect the equipment.
MSUT and combiner.
2. "Set the test parameter \hat{I}_{or} ." on page 188.
Set the test parameter \hat{I}_{or} .
Screen: CDMA CALL CONTROL
Enter value in: **Sector A Power**
3. "Set the Test Set to ignore all access attempts." on page 189.
Screen: CDMA CALL CONTROL
Enter value in: **Call Limit**
4. "Register the MSUT." on page 190.
Screen: CDMA CALL CONTROL
Select **Register**
5. "Set MAX_RSP_SEQ to 1." on page 191.
Screen: CDMA CELL SITE CONFIGURATION
Enter value in: **Max Rsp Seq**
6. "Measure access probe power." on page 192.
Press: CALL key
Screen: CDMA CALL CONTROL
Observe: **Page Sent, Access Probe, Connected**
7. "Change the access parameters message." on page 193.
Screen: CDMA CELL SITE CONFIGURATION
Enter value in: **Nom Power, Init Power, Power Step, Num Step, Max Rsp Seq**
8. "Measure access probe power." on page 194.
Press: CALL key
Screen: CDMA CALL CONTROL
Observe: **Page Sent, Access Probe, Connected**

HPBASIC Programming Example

The following programming example was developed using HPBASIC for Windows. It was tested on an HP 8924C with firmware rev A.02.26.

```
10 ! RE-STORE "c:\hpbasic\setrain\access_probe"
20 ! This program measures Access Probe Output Power
30 Loss=-1.5
40 CLEAR 714
50 OUTPUT 714;"*CLS"
60 CLEAR SCREEN
70 OUTPUT 714;"CDMA:CALL:END"
80 WAIT 1
90 OUTPUT 714;"*RST;"
100 WAIT 3
110 OUTPUT 714;"CDMA:RFCH 384"
115 !Measure access probe power during 1 access probe sequence
120 Meas(1,1,Loss)
130 CLEAR SCREEN
135 !Measure access probe power during 3 access probe sequences
140 Meas(2,3,Loss)
150 !
160 DISP "Program Done"
170 END
180 Meas: SUB Meas(Test,Max_seq,Loss)
190 IF Test=1 THEN
200 OUTPUT 714;"CONF:OFL:RFIN ";Loss
210 OUTPUT 714;"CONF:OFL:MODE 'ON'"
220 !
230 OUTPUT 714;"CDMA:CALL:LIM 'PAGE'"!Limit call processing to page
240 !Mobile station will transmit its maximum number of access probes
250 !as defined by settings on the Cell Configuration screen
260 OUTPUT 714;"CDMA:CELL:ASEC:BWP -75"
270 OUTPUT 714;"CDMA:CELL:CONF:MAXR";Max_seq
280 OUTPUT 714;"CDMA:CELL:CONF:STEP:POW 0"!Power Step = 0
290 ELSE
300 OUTPUT 714;"CDMA:CELL:CONF:MAXR";Max_seq
310 OUTPUT 714;"CDMA:CELL:CONF:NOM:POW 3"!Nominal power = 3
```

```
320 OUTPUT 714;"CDMA:CELL:CONF:INIT:POW 3"!Initial power = 3
330 OUTPUT 714;"CDMA:CELL:CONF:STEP:POW 1"!Power Step = 1
340 OUTPUT 714;"CDMA:CELL:CONF:NUMS 4"!Number of steps = 4
350 END IF
360 Spec_an1(Test) !Set up Spectrum Analyzer
370 PRINT
380 PRINT "PRESS CONTINUE AND COUNT THE NUMBER OF"
390 PRINT "ACCESS PROBES AS THEY APPEAR ON THE DISPLAY"
400 PAUSE
410 CLEAR SCREEN
420 WAIT 1
430 PRINT "TOTAL ACCESS PROBES SHOULD BE ";Max_seq*5
440 OUTPUT 714;"CDMA:CALL:MAKE"
450 DISP "Call attempt made"
460 IF Test=1 THEN
470 WAIT 10
480 PRINT
490 CLEAR SCREEN
500 END IF
510 SUBEND
520 Spec_an1: SUB Spec_an1(Test)
530 IF Test=1 THEN
540 PRINT "1. CONNECT THE MOBILE OUTPUT TO A SPECTRUM"
545 PRINT "ANALYZER USING A POWER SPLITTER OR COMBINER"
550 PRINT " (ISOLATION IS NOT IMPORTANT) "
560 PRINT
570 PRINT
580 PRINT "2. SET UP THE SPECTRUM ANALYZER AS FOLLOWS:"
590 PRINT " Reference level: 20 dBm"
600 PRINT " Span 0 Hz"
610 PRINT " Vertical scale: 5 dB/DIV"
620 PRINT " Sweep Time: 5 seconds"
625 !OUTPUT 714;"RFG:FREQ:UNIT MHZ"
630 OUTPUT 714;"RFG:FREQ?"
640 ENTER 714;Freq
650 PRINT " Center Frequency: ";Freq
660 END IF670 SUBEND
```

CDMA to Analog Handoff

Performing a CDMA to Analog Handoff

The HP 8924C has the capability to perform a handoff from a CDMA traffic channel to an analog voice channel. The following conditions are required for a successful handoff:

- The MSUT must be programmed to allow analog operation.
- A CDMA phone call must be active (Connected annunciator lit).
- The MSUT may require the audio to be muted if the environment is noisy. If the audio mute feature does not exist in the mobile station, a field called SAT Tolerance can be set to “Wide” to allow SAT to be detected in the presence of noise.

1. Make sure the MSUT will allow analog operation.**Manual Operation:**

Program the MSUT to “prefer digital” or “prefer analog” operation.

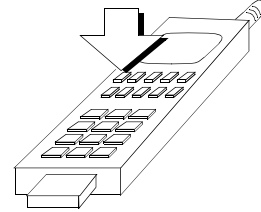

Refer to the MSUT manufacturers procedure for setting the MSUT to the correct mode.

2. Specify “Wide” SAT Tolerance. (Optional)

Manual Operation:

1. Select the ANALOG SCRNS: CALL CONTROL screen.
2. Select the ANALOG SCRNS: CALL CONFIGURE screen from To Screens:.
3. Position the cursor next to the Sat Tol field.
4. Select Wide.

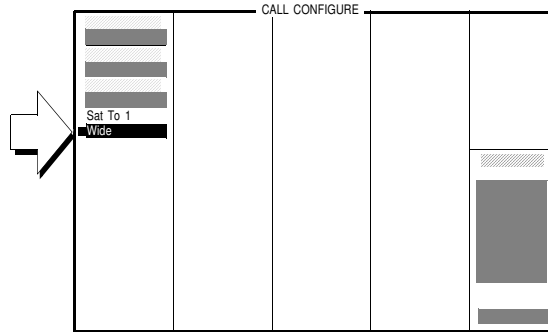

In some applications, such as when a mobile station's audio section cannot be muted, and background noise is present, the Test Set will not will not respond to the SAT tone transponded by the mobile station unless a wider filter is applied in the Test Set's audio demodulation path.

HP-IB Syntax:

"CALLP:STOL 'Wide'"!selects a wider filter for demodulating the selected SAT.

3. Make a CDMA call.

See "[Setting up a Call](#)" on [page 52](#) if you are not familiar with how this procedure is performed with the Test Set. Any service option can be used.

After setting up the CDMA call, return to this procedure.

4. Select an analog system for handoffs.

Manual Operation:

1. Select the CDMA CALL CONTROL screen.
2. Position the cursor next to the System Type field as shown in the figure.
3. Select the analog system supported by the MSUT.

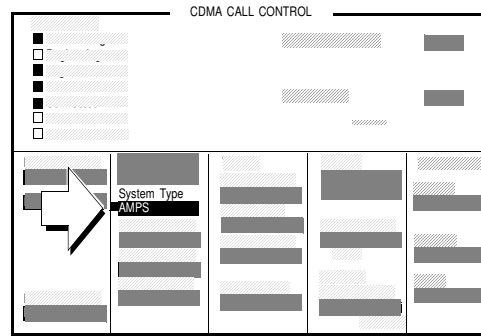

HP-IB Syntax:

`"CDMA:CALL:AHANdoff:STYPe 'AMPS'!"` selects the AMPS analog system for CDMA to analog handoffs.

5. Set up handoff parameters. (Optional)

Manual Operation:

1. Position the cursor next to the Channel, SAT, or Pwr Level fields as needed to specify handoff parameters.
2. Select the analog parameters in each of these three fields.

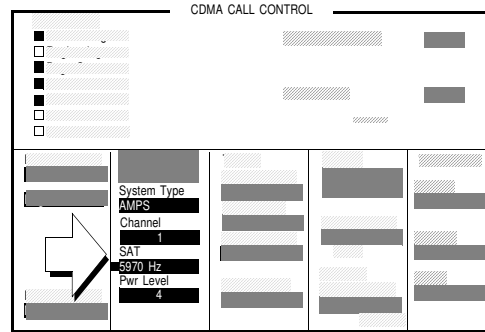

These three fields provide the Test Set with information about how to set up the simulated analog cell site for the handoff to an analog voice channel. The three fields are:

Channel: The analog voice channel that will be allocated for CDMA to analog handoffs.

SAT: The supervisory audio tone that the Test Set will transmit, and the MSUT will transpond.

Pwr Level: The power level to be transmitted by the mobile station after the handoff is successful, referred to as VMAC (voice mobile attenuation code).

HP-IB Syntax:

`"CDMA:CALL:AHAN:CHAN 1"`!sets the Channel (analog voice channel) field to 1.

`"CDMA:CALL:AHAN:SAT '6000Hz'"`!sets the SAT (supervisory audio tone to 6000 Hz.

`"CDMA:CALL:AHAN:PLEV 4"`! sets the Pwr Level (voice mobile attenuation code) to 4.

6. Select the Execute field.

Manual Operation:

1. If you performed step 5, return to the CDMA CALL CONTROL screen.
2. Position the cursor next to the Execute field as shown in the figure.
3. Press the knob to execute a CDMA to analog handoff.

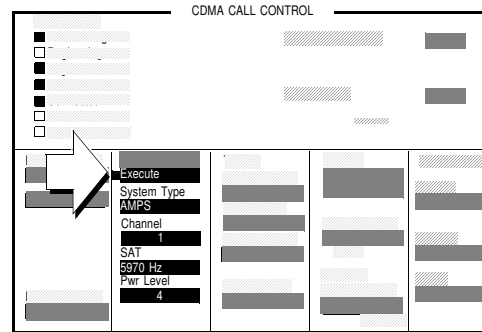

When a CDMA to analog handoff is attempted, the Test Set switches to analog mode, configures itself as an analog cell site, and displays the CALL CONTROL screen. This is the screen that controls analog call processing. If the handoff is successful, the Connected annunciator will be lit.

See "264 Using the Analog Call Processing Subsystem" on page 263 to make measurements and perform other operations in analog mode.

HP-IB Syntax:

`"CDMA:CALL:AHAN:EXEC"!executes the CDMA to analog handoff.`

7. Verify that the handoff was successful.

Manual Operation:

Check the Connect annunciator.

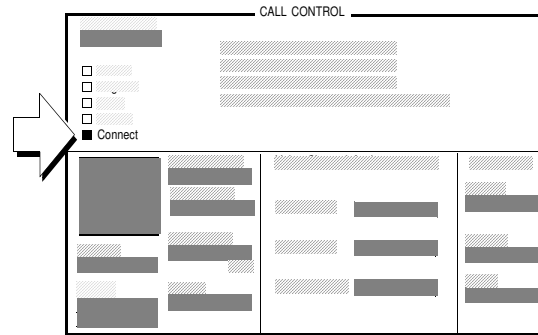

When a CDMA to analog handoff is attempted, the Test Set switches to analog mode, configures itself as an analog cell site, and displays the CALL CONTROL screen. This is the screen that controls analog call processing. If the handoff is successful, the Connect annunciator will be lit.

See "264 Using the Analog Call Processing Subsystem" on page 263 to make measurements and perform other operations in analog mode.

HP BASIC Example

The following example executes a CDMA to analog handoff, then polls bit 5 in the Call Processing status register group until the handoff to the analog voice channel is connected, or the handoff attempt times out.

```
10 RE-SAVE "C:\HPBASIC\HANDOFF"  
20 OUTPUT 714;"CDMA:CALL:AHAN:EXEC"!executes the CDMA to analog handoff  
30 T=TIMEDATE  
40 REPEAT  
50 OUTPUT 714;"STAT:CALLP:EVENT?" !Queries Call Processing Status Event Register  
60 ENTER 714;Connected  
70 IF TIMEDATE-T>=25 THEN  
80 PRINT "ERROR"  
90 STOP  
100 ELSE  
110 WAIT .1 !Prevents HP-IB commands from dominating TesFlkt Set processes  
120 END IF  
130 UNTIL BIT(Connected,5)  
140 PRINT "Handoff complete, mobile is connected to analog voice channel"  
140 END
```

Procedure Overview

1. "Make sure the MSUT will allow analog operation." on page 201.
2. "Specify "Wide" SAT Tolerance. (Optional)" on page 202.

Screen: CALL CONFIGURE

Select: **Wide**.

3. "Make a CDMA call." on page 203.

See "Setting up a Call" on page 52

4. "Select an analog system for handoffs." on page 204.

Screen: CDMA CALL CONTROL

Select the: **MSUT System**.

5. "Set up handoff parameters. (Optional)" on page 205.

Screen: CDMA CALL CONTROL

Enter values for: **Channel, SAT, or Pwr Level**

6. "Select the Execute field." on page 206.

Screen: CDMA CALL CONTROL

Select: **Execute**

7. "Verify that the handoff was successful." on page 207.

Screen: CALL CONTROL CONTROL

Observe: **Connect** annunciator

Authentication Tests

The following Authentication tests verify that the Mobile Station Under Test (MSUT) is able to use the Cellular Authentication and Voice Encryption (CAVE) algorithm correctly.

For Authentication tests to pass, the MSUT and Test Set must possess identical sets of Shared Secret Data (SSD). SSD consists of two subsets:

- SSD_A (used for Authentication procedures) and
- SSD_B (used to support voice privacy)

NOTE:

In this section, the acronym SSD will be used to refer to SSD_A.

Authentication test results are displayed in a portion of the display referred to as the Authentication Data Table.

CDMA AUTHENTICATION			
Registration with Authen: Passed			
Registration Type: Power-up			
Parameter	Expected	Received	Status
AUTHR	-	-	
RANDC	-	-	
COUNT	-	-	
AUTH_MODE	0	0	Passed

← Authentication Data Table

List of CDMA Authentication Tests

"Initializing SSD to Zero" on page 213.

"Updating SSD" on page 222.

"Performing a Unique Challenge-Response" on page 230.

Initializing SSD to Zero

This procedure tests the MSUT's ability to respond to a timer-based registration with authentication parameters that match the values expected by the Test Set.

This procedure is performed after SSD has been initialized to zero in both the Test Set and MSUT. SSD is initialized to zero by changing the A-Keys. *If you cannot change the A-Key in the MSUT, you cannot perform this test.*

NOTE:

SSD is not directly accessible in any fields on the Test Set's display.

1. Register the MSUT.

If the MSUT is already registered, this step is not necessary.

See "**Setting up a Call**" on page 52 if you are not familiar with how this procedure is performed with the Test Set.

Registration provides the Test Set with the MSUT's ESN (Electronic Serial Number).

ESN is displayed in the MS Database field.

Authentication procedures rely on ESN to generate valid A-Keys and compute numbers used to check for possession of identical SSD (shared secret data) between the MSUT and Test Set.

2. Initialize the Test Set's SSD to zero.

Manual Operation:

1. Select Authen in the To Screen, CDMA list.
 If the SSD_A=0 annunciator is lit, performing the rest of this step is not necessary.
2. Position the cursor in front of the A-Key field.
3. Enter any number within the allowable range of A-Key values, using the DATA keys. Press the ENTER key when the number has been entered.

The SSD_A=0 annunciator should be lit.

The Check Digits field should display a six-digit number.¹

CDMA AUTHENTICATION			
Call Status	Registration with Authen: Passed		
<input checked="" type="checkbox"/> Transmitting	Registration Type: Power-up		
<input type="checkbox"/> Registering			
<input type="checkbox"/> Page Sent			
<input type="checkbox"/> Access Probe	Parameter	Expected	Received Status
<input type="checkbox"/> Connected	AUTHR	-	-
<input type="checkbox"/> SSD Update	RANDC	-	-
<input type="checkbox"/> Unia Chall	COUNT	-	-
<input checked="" type="checkbox"/> SSD_A=0	AUTH_MODE	0	0 Passed
A_KEY	Check Digits	To Screen	
00000000000000000000	174518		
Authen	Traffic	MS Database	
On/Off	Data Mode	ESN	
Timer Reg	Svc Opt 1	B08197F4	
On/Off	Data Type		
SSD Update	Echo		
Execute	Echo Delay		
Unia Chall	2 Seconds		
Execute	Authen Data		
	Clear		

Entering an A-Key initializes SSD to zero.

The range of values allowed in the A-Key field is 0 to 18446744073709551615.

The number you entered in the A-Key field, along with the MSUT's ESN acquired during registration, are used by the Test Set to generate the six digits displayed in the Check Digits field. If no Check Digits appear, make sure an ESN value is displayed in the MS Database field.¹

The Check Digits are part of the A-Key, and provide a method for checking A-Key validity.

If the ESN changes (for instance when another MSUT is connected to the Test Set and registers) or is cleared, the Check Digits field will be cleared.

1. If Kor PCS is selected in the Protocol field, the Check Digits field should be blank.

HP-IB Syntax

"CDMA:AUTH:AKEY '0'" enters all zeroes in the A-Key field.

3. Initialize the MSUT's SSD to zero.

1. Access the MSUT's A-Key register and enter the identical sequence of digits displayed in the A-Key field, followed by the six Check Digits (if protocol is not Kor PCS).

The MSUT should confirm the entry of a valid A-Key.

This step instructs you to enter the A-Key displayed in the A-Key field because it is assumed to be valid (the Test Set calculated Check Digits based on the 20 A-Key digits and MSUT's ESN acquired during registration). This procedure, however, will work with any valid A-Key, since any valid A-Key will initialize the MSUT's SSD to zero.

If you cannot change the MSUT's A-Key but you know what it is, enter it in the A-Key field on the Test Set (as described in the previous step), then skip to "[Updating SSD](#)" on page 222.

4. Turn on Authentication.

Manual Operation:

1. Position the cursor at the Authen field.
2. Press the knob to select On.



CDMA AUTHENTICATION			
Call Status <input checked="" type="checkbox"/> Transmitting <input type="checkbox"/> Registering <input type="checkbox"/> Page Sent <input type="checkbox"/> Access Probe <input type="checkbox"/> Connected <input type="checkbox"/> SSD Update <input type="checkbox"/> Unia Chall <input checked="" type="checkbox"/> SSD_A=0			
Registration with Authen: Passed Registration Type: Power-up			
	Parameter	Expected	Received Status
	AUTHR	-	-
	RANDC	-	-
	COUNT	-	-
	AUTH_MODE	0	0 Passed
A_KEY	Check Digits	MS ID	To Screen
00000000000000000000	174518	Auto	<input checked="" type="checkbox"/> CDMA <input type="checkbox"/> CALL CNTL <input type="checkbox"/> SMS <input type="checkbox"/> AUTHEN <input type="checkbox"/> Analog <input type="checkbox"/> RX TEST <input type="checkbox"/> Config <input type="checkbox"/> TESTS
Authen		Traffic	
On/Off		Data Mode	
Timer Res		Svc Opt 1	MS Database
On/Off		Data Type	ESN
SSD Update		Echo	B08197F4
Execute		Echo Delay	
Unia Chall	Authen Data	2 Seconds	
Execute	Clear		

Selecting "On" in this field results in the Test Set signaling the MSUT to include authentication parameters in messages requiring authentication (AUTH_MODE =1).

HP-IB Syntax

"CDMA:CELL:CONF:AUTH:MODE 'ON'" turns authentication on.
 "CDMA:AUTH:DATA:CLE" clears the Authentication Data Table.

5. Perform a timer-based registration.

Manual Operation:

1. Position the cursor at the Timer Reg field.
2. Press the knob to select On.
3. Wait for the first registration to complete (about 20 seconds).

Read the Registration with Authen: message in the Authentication Data Table. It will indicate whether the registration passed or failed.

If the test failed, check the passed or failed status of each the following parameters: AUTHR, RANDC, COUNT, and AUTH_MODE to see which parameters did not match expected values.

After the first timer-based registration is performed, the expected COUNT parameter will be "Unknown." The Status of COUNT will be "Failed," until the next registration when an Expected COUNT parameter is available.

Registrations should occur at about 20 second intervals.

The MSUT and Test Set combine SSD with a random number and the ESN of the phone when computing AUTHR. This value is transmitted by the MSUT, then compared (along with other Authentication parameters) with the expected value by the Test Set to determine Pass/Fail status.

CDMA AUTHENTICATION				
Call Status				
Registration with Authen: Failed				
Registration Type: Tiner				
<input checked="" type="checkbox"/> Transmitting	Parameter	Expected	Received	Status
<input type="checkbox"/> Registering	AUTHR	250EA	250EA	Passed
<input type="checkbox"/> Page Sent	RANDC	34	34	Passed
<input type="checkbox"/> Access Probe	COUNT	Unknown	3	Failed
<input type="checkbox"/> Connected	AUTH_MODE	1	1	Passed
<input type="checkbox"/> SSD Update				
<input type="checkbox"/> Unia Chall				
<input checked="" type="checkbox"/> SSD_A=0				
A_KEY	Check Digits	MS ID	To Screen	
00000000000000000000	139763	Auto	<input checked="" type="checkbox"/> CDMA <input type="checkbox"/> CALL CNTL <input type="checkbox"/> SMS <input type="checkbox"/> AUTHEN <input type="checkbox"/> Analog <input type="checkbox"/> RX TEST <input type="checkbox"/> Config <input type="checkbox"/> TESTS	
Authen		Traffic		
On/Off		Data Mode		
Timer Reg		Sub Opt 1		
On/Off		Data Type		
SSD Update		Echo		
Execute	Authen Data	Echo Delay		
Unia Chall	Clear	2 Seconds		
Execute				

CDMA AUTHENTICATION				
Call Status				
Registration with Authen: Passed				
Registration Type: Tiner				
<input checked="" type="checkbox"/> Transmitting	Parameter	Expected	Received	Status
<input type="checkbox"/> Registering	AUTHR	5CEE	5CEE	Passed
<input type="checkbox"/> Page Sent	RANDC	34	34	Passed
<input type="checkbox"/> Access Probe	COUNT	1B	1B	Passed
<input type="checkbox"/> Connected	AUTH_MODE	1	1	Passed
<input type="checkbox"/> SSD Update				
<input type="checkbox"/> Unia Chall				
<input checked="" type="checkbox"/> SSD_A=0				
A_KEY	Check Digits	MS ID	To Screen	
00000000000000000000	174518	Auto	<input checked="" type="checkbox"/> CDMA <input type="checkbox"/> CALL CNTL <input type="checkbox"/> SMS <input type="checkbox"/> AUTHEN <input type="checkbox"/> Analog <input type="checkbox"/> RX TEST <input type="checkbox"/> Config <input type="checkbox"/> TESTS	
Authen		Traffic		
On/Off		Data Mode		
Timer Reg		Sub Opt 1		
On/Off		Data Type		
SSD Update		Echo		
Execute	Authen Data	Echo Delay		
Unia Chall	Clear	2 Seconds		
Execute				

HP-IB Syntax

"CDMA:CELL:CONF:TREG:MODE 'ON'" turns timer-based registration on.
 "CDMA:AUTH:DATA?" queries the results displayed in the Authentication Data Table.

NOTE:

Querying the results displayed in the Authentication Data Table returns a series of 18 numeric values separated by commas. Refer to the *HP 8924C Reference Guide*, Description of Fields, [Authentication Data Table](#) for a description of each value and a programming example.

HP-IB Help

The CDMA Authentication Status Register provides status bits that can simplify remote operation.

Below is a program example that queries the CDMA Authentication Event Register to determine if authentication is in progress, and if an authentication procedure passed. This program assumes that the MSUT has found service, and that the Test Set and MSUT possess identical shared secret data. It will run until a timer-based registration passes.

```

10 ! RE-SAVE "c:\8924c\authentic\auth_status3"
20 ON TIMEOUT 7,10 GOTO 240
30 CLEAR 714
40 CLEAR SCREEN
45 OUTPUT 714;"*CLS" !Clear Event registers
50 OUTPUT 714;"DISP Caut"
60 OUTPUT 714;"*CLS" !Clear out event bit registers
70 OUTPUT 714;"CDMA:CELL:CONF:AUTH:MODE 'ON'" !Turn authentication on
80 OUTPUT 714;"CDMA:CELL:CONF:TREG:MODE 'ON'" !Enable timer-based registration
90 LOOP
100 WAIT .5
110 OUTPUT 714;"STAT:CAUT:EVEN?"!Read CDMA Authentication Event Register
120 ENTER 714;Auth
130 !*****
140 IF BIT(Auth,0) THEN !Bit 0 is latched high when Authentication begins
150 PRINT "Authentication in Progress..."
160 END IF
170 !
180 IF BIT(Auth,7) THEN !Bit 7 is latched high when Registration passes
190 PRINT "Registration with authentication passed"
200 END IF
210 !*****
220 EXIT IF Auth>=128 !Stop program when Registration passes
230 END LOOP
240 STOP
250 END

```

For a full description of CDMA Authentication Status Register bits, refer to the *HP 8924C User's Guide*, [Status Reporting](#).

6. Disable timer-based registration.

Manual Operation:

1. Position the cursor at the Timer Reg field.
2. Press the knob to select Off.

CDMA AUTHENTICATION

Registration with Authen: Passed
 Registration Type: Timer

Parameter	Expected	Received	Status
AUTHR	5CEE	5CEE	Passed
RANDC	34	34	Passed
COUNT	1B	1B	Passed
AUTH_MODE	1	1	Passed

A_KEY 00000000000000000000	Check Digits 174518	MS ID Auto	To Screen ● CDMA CALL CNTL SMS AUTHEN
-------------------------------	------------------------	---------------	---

Authen On/Off Timer Reg On/Off SSD Update Execute Unia Chall Execute	Authen Data Clear	Traffic Data Mode Svc Opt 1 Data Type Echo Echo Delay 2 Seconds	MS Database ESN B08197F4 ○ Analog RX TEST Config TESTS
---	----------------------	---	--

HP-IB Syntax

"CDMA:CELL:CONF:TREG:MODE 'OFF'" turns timer-based registration off.

220

N:\mkt\MANUALS\HP8924C\APPMOD\BOOK\CHAPTERS\amauth.fb

www.valuetronics.com

Measurement Overview

1. **"Register the MSUT."** on page 214.
See **"Setting up a Call"** on page 52.
2. **"Initialize the Test Set's SSD to zero."** on page 215.
Screen: CDMA AUTHENTICATION
Enter value in: **A-Key**
3. **"Initialize the MSUT's SSD to zero."** on page 216.
4. **"Turn on Authentication."** on page 217.
Screen: CDMA AUTHENTICATION
Make selection in **Authen**
5. **"Perform a timer-based registration."** on page 218.
Screen: CDMA AUTHENTICATION
Make selection in **Timer Reg**
6. **"Disable timer-based registration."** on page 220.
Screen: CDMA AUTHENTICATION
Make selection in **Timer Reg**

It is recommend these additional procedures be performed after initializing SSD to zero to further verify correct MSUT performance:

- **"MSUT-Originated Call"** on page 64
- **"MSUT-Terminated Call"** on page 63
- **"Performing a Unique Challenge-Response"** on page 230

Updating SSD

SSD Update tests the MSUT's ability to synchronize SSD with the Test Set.

This procedure will show you how to perform SSD Update on the Paging/Access channels. SSD Updates can also be performed on the Traffic channels by making a call as described in "[MSUT-Terminated Call](#)" on page 63, then performing this procedure.

During the SSD update, the Test Set and MSUT acquire new sets of SSD using their current A-Keys. The Test Set and the MSUT then compare the new SSD values and the MSUT sends a message to the Test Set confirming or rejecting the new value.

No authentication parameters are displayed in the CDMA Authentication table during this test.

1. Register the MSUT or Set Up a Call.

If the MSUT is already registered or a call is connected, this step is not necessary.

See "[Setting up a Call](#)" on page 52 if you are not familiar with how either of these procedures is performed using the Test Set.

Setting up a call registers the MSUT.

Registration provides the Test Set with the MSUT's ESN (Electronic Serial Number).

ESN is displayed in the MS Database field.

Authentication procedures rely on ESN to generate valid A-Keys and generate other values used to check for possession of identical SSD between the MSUT and Test Set.

2. Enter the MSUT's A-Key into the Test Set.

If you performed "Initializing SSD to Zero" on page 213, this step is not necessary.

Manual Operation:

1. Enter the most significant 20 digits (non-check-digits) of the MSUT's A-Key into the Test Set's A-Key field using the DATA keys. Press the ENTER key when you are done.

The SSD_A=0 annunciator should be lit.

2. Compare the numbers in the Check Digits field with the last 6 digits in the MSUT's A-Key. If they do not match, one of the A-Keys is not valid. Check the 20-digit sequence entered in the Test Set to be sure it matches the MSUT's A-Key.

CDMA AUTHENTICATION			
Registration with Authen: Passed			
Registration Type: Tiner			
Parameter	Expected	Received	Status
AUTHR	5CEE	5CEE	Passed
RANDC	34	34	Passed
COUNT	1B	1B	Passed
AUTH_MODE	1	1	Passed

A-KEY	Check Digits	MS ID	To Screen
00000000000000000000	174518	Auto	<input checked="" type="radio"/> CDMA <input type="radio"/> CALL CNTL <input type="radio"/> SMS <input type="radio"/> AUTHEN <input type="radio"/> Analog <input type="radio"/> RX TEST <input type="radio"/> Config <input type="radio"/> TESTS

Authen	Traffic	MS Database	
On/Off	Data Mode	ESN	
Timer Res	Svc Opt 1	B08197F4	
On/Off	Data Type		
SSD Update	Echo		
Execute	Echo Delay		
Unia Chall	2 Seconds		
Execute	Authen Data		
	Clear		

If you do not know the MSUT's A-Key, and have no way of finding out what it is, try entering zero in the A-KEY field. The A-Key in many MSUT's is initially programmed to zero until re-programmed by the service provider.

HP-IB Syntax

"CDMA:AUTH:AKEY '0'" enters all zeroes in the A-Key field.

224

N:\mkt\MANUALS\HP8924C\APPMOD\BOOK\CHAPTERS\amauth.fb

www.valuetronics.com

3. Turn Authentication On

Manual Operation:

1. Position the cursor at the Authen field
2. Press the knob to select On.



CDMA AUTHENTICATION			
Call Status Page with Authen: Passed			
<input checked="" type="checkbox"/> Transmitting	Parameter	Expected	Received Status
<input type="checkbox"/> Registering	AUTHR	5CEE	5CEE Passed
<input checked="" type="checkbox"/> Page Sent	RANDC	34	34 Passed
<input checked="" type="checkbox"/> Access Probe	COUNT	1B	1B Passed
<input checked="" type="checkbox"/> Connected	AUTH_MODE	1	1 Passed
<input type="checkbox"/> SSD Update			
<input type="checkbox"/> Unia Chall			
<input checked="" type="checkbox"/> SSD_A=0			
A_KEY	Check Digits	MS ID	To Screen
00000000000000000000	174518	Auto	<input checked="" type="radio"/> CDMA CALL CNTL SMS AUTHEN <input type="radio"/> Analog RX TEST Config TESTS
Authen		Traffic	
On/Off		Data Mode	
Timer Req		Svc Opt 1	MS Database
On/Off		Data Type	ESN
SSD Update		Echo	B08197F4
Execute		Echo Delay	
Unia Chall	Authen Data	2 Seconds	
Execute	Clear		

Turning Authentication "On" sets the AUTH_MODE bit to "01" in signaling messages and causes the MSUT to send Auth parameters AUTHR, RANDC, and COUNT to the Test Set.

HP-IB Syntax

"CDMA:CELL:CONF:AUTH:MODE 'ON' " turns authentication on.

4. Perform an SSD Update

Manual Operation:

- Select the SSD Update Execute field.

The SSD Update annunciator will light, but this may be only momentarily.

CDMA AUTHENTICATION

Call Status			
<input checked="" type="checkbox"/> Transmitting			
<input type="checkbox"/> Registering			
<input checked="" type="checkbox"/> Page Sent		Parameter	Expected Received Status
<input checked="" type="checkbox"/> Access Probe			
<input checked="" type="checkbox"/> Connected			
<input checked="" type="checkbox"/> SSD Update			
<input type="checkbox"/> Unia Chall			
<input checked="" type="checkbox"/> SSD_A=0			

A_KEY 000000000000000000000000	Check Digits 174518	MS ID Auto	To Screen
Authen On/Off	Timer Req On/Off	Traffic Data Mode Suc Opt 1 Data Type Echo Echo Delay 2 Seconds	<input checked="" type="checkbox"/> CDMA <input type="checkbox"/> CALL CNTL <input type="checkbox"/> SMS <input type="checkbox"/> AUTHEN <input type="checkbox"/> Analog <input type="checkbox"/> RX TEST <input type="checkbox"/> Config <input type="checkbox"/> TESTS
SSD Update Execute	Unia Chall Execute	Authen Data Clear	MS Database ESN B08197F4

During the SSD Update, the MSUT and Test Set combine the A-Key with a common random number, RANDSSD, and then compare results to determine if SSD matches. RANDSSD is a settable value (see RANDSSD field on the CDMA CELL SITE CONFIGURATION screen) sent from the Test Set to the MSUT.

HP-IB Syntax

"CDMA:AUTH:SSD" initiates an SSD Update.

226

N:\mkt\MANUALS\HP8924C\APPMOD\BOOK\CHAPTERS\amauth.fb

www.valuetronics.com

5. Check the message displayed for test results.

Manual Operation:

Read the SSD Update on Paging (or Traffic): message. It will indicate whether SSD Update passed or failed.

After a successful SSD Update, the SSD_A=0 annunciator should no longer be lit.

CDMA AUTHENTICATION

SSD Update on Traffic: Passed

<input type="checkbox"/> Transmitting		<u>Parameter</u>	<u>Expected</u>	<u>Received</u>	<u>Status</u>
<input type="checkbox"/> Registering		None			
<input type="checkbox"/> Page Sent					
<input type="checkbox"/> Access Probe					
<input type="checkbox"/> Connected					
<input type="checkbox"/> SSD Update					
<input type="checkbox"/> Unia Chall					
<input type="checkbox"/> SSD_A=0					

A_KEY 00000000000000000000	Check Digits 139763	MS ID Auto	To Screen
Authen On/Off	Authen Data Clear	Traffic Data Mode Svc Opt 1 Data Type Echo Echo Delay 2 Seconds	MS Database ESN B0000000
Timer Res On/Off			• CDMA CALL CNTL SMS AUTHEN
SSD Update Execute			O Analog RX TEST
Unia Chall Execute			Config TESTS

After new values for SSD are computed and compared between the MSUT and Test Set, the MSUT transmits a message to the Test Set indicating the status of the SSD Update (passed or failed).

HP-IB Syntax

"CDMA:AUTH:DATA?" queries the results displayed in the Authentication Data Table.

NOTE:

Querying the Authentication Data Table returns a series of 18 numeric values separated by commas. Each numeric value represents data displayed in the Authentication Data Table. Refer to the *HP 8924C Reference Guide, Description of Fields, Authentication Data Table* for description of each value and a programming example.

HP-IB Help

The CDMA Authentication Status Register provides status bits that can simplify remote operation.

Below is a program example that queries the CDMA Authentication Event Register to determine if an SSD Update is in progress, and if an SSD Update passed. This program assumes that the MSUT has registered or is on a call, and that the Test Set's A-Key field and the MSUT's A-Key match.

227

N:\mkt\MANUALS\HP8924C\APPMOD\BOOK\CHAPTERS\amauth.fb

www.valuetronics.com

Chapter 6, Authentication Tests

Updating SSD

```
10 ! RE-SAVE "c:\8924c\authentic\auth_status4"
20 ON TIMEOUT 7,10 GOTO 240
30 CLEAR 714
40 CLEAR SCREEN
50 OUTPUT 714;"DISP CAUT"
60 OUTPUT 714;"*CLS" !Clear out event bit registers
70 OUTPUT 714;"CDMA:CELL:CONF:AUTH:MODE 'ON'" !Turn authentication on
80 OUTPUT 714;"CDMA:AUTH:SSD" !Initiate SSD Update
90 LOOP
100 WAIT .5
110 OUTPUT 714;"STAT:CAUT:EVEN?"!Read CDMA Authent Event Register
120 ENTER 714;Auth
130 !*****
140 IF BIT(Auth,1) THEN !Bit 1 is latched high when an SSD Update begins
150 PRINT "SSD Update in Progress..."
160 END IF
170 !
180 IF BIT(Auth,11) THEN !Bit 11 is latched high when SSD Update passes
190 PRINT "SSD Update with authentication passed"
200 END IF
210 !*****
220 EXIT IF Auth>=256 !Stop program when SSD Update passes
230 END LOOP
240 STOP
250 END
```

For a full description of CDMA Authentication Status Register bits, refer to the *HP 8924C User's Guide*, [Status Reporting](#).

Measurement Overview

1. **"Register the MSUT or Set Up a Call." on page 223.**
See **"Setting up a Call" on page 52.**
2. **"Enter the MSUT's A-Key into the Test Set." on page 224.**
3. **"Turn Authentication On" on page 225.**
Screen: CDMA AUTHENTICATION
Enter value in: **A-Key**
4. **"Perform an SSD Update" on page 226.**
Screen: CDMA AUTHENTICATION
Make selection in **Timer Reg**
5. **"Check the message displayed for test results." on page 227.**
Screen: CDMA AUTHENTICATION
Observe: Authentication Data Table.

It is recommend the following procedures be performed after Updating SSD to further verify correct MSUT performance:

- **"Performing a Unique Challenge-Response" on page 230**

Performing a Unique Challenge-Response

Unique Challenge-Response tests the MSUT's ability to send the Test Set a parameter that indicates it has SSD identical to the Test Set's.

This procedure will show you how to perform a Unique Challenge-Response procedure on the Paging/Access and Traffic channels. The MSUT should respond with a computed value for AUTHU, which the Test Set will compare with an expected value to determine Pass/Fail status.

1. Synchronize SSD between the Test Set and MSUT.

Manual Operation:

1. Perform either:
 - *Initializing SSD to Zero, or
 - * Updating SSD

Performing either of these procedures synchronizes the SSD value stored in the Test Set with the SSD value stored in the MSUT.

2. Select Unique Challenge.

Manual Operation:

1. End a call if Call Status is Connected
2. Select the Uniq Chall field.

The Uniq Chall annunciator should light momentarily.

CDMA AUTHENTICATION

Call Status		Parameter		Expected	Received	Status
<input checked="" type="checkbox"/>	Transmitting					
<input type="checkbox"/>	Registering					
<input type="checkbox"/>	Page Sent					
<input type="checkbox"/>	Access Probe					
<input type="checkbox"/>	Connected					
<input type="checkbox"/>	SSD Update					
<input checked="" type="checkbox"/>	Uniq Chall					
<input checked="" type="checkbox"/>	SSD_A=0					

A_KEY	Check Digits	MS ID	To Screen
00000000000000000000	174518	Auto	● CDMA CALL CNTL SMS AUTHEN ○ Analog RX TEST Config TESTS

Authen On/Off Timer Req On/Off SSD Update Execute Uniq Chall Execute	Authen Data Clear	Traffic Data Mode Svc Opt 1 Data Type Echo Echo Delay 2 Seconds	MS Database ESN B08197F4
---	----------------------	---	--------------------------------

This step performs a Unique Challenge on the Paging/Access channels.

HP-IB Syntax

"CDMA:AUTH:UCH" !initiates the Unique Challenge procedure

3. Check the Authentication Data Table for results.

Manual Operation:

1. End a call if Call Status is Connected
2. Select the Uniq Chall field.

Read the Unique Challenge on Paging (or Traffic): message. It will indicate whether the Unique Challenge passed or failed.

Check the Authentication Data Table for AUTHU Pass/Fail results.

CDMA AUTHENTICATION

Unique Challenge on Paging: Passed

Parameter	Expected	Received	Status
AUTHU	3084B	3084B	Passed

A_KEY 00000000000000000000	Check Digits 174518	MS ID Auto	To Screen ● CDMA CALL CNTL SMS AUTHEN ○ Analog RX TEST Config TESTS
Authen On/Off Timer Res On/Off SSD Update Execute Unia Chall Execute	Authen Data Clear	Traffic Data Mode Svc Opt 1 Data Type Echo Echo Delay 2 Seconds	MS Database ESN B08197F4

If the Unique Challenge on Paging (or Traffic): Failed message appears, it means that AUTHU did not match the expected value.

HP-IB Syntax

"CDMA:AUTH:DATA?" queries the results displayed in the Authentication Data Table.

NOTE:

Querying the Authentication Data Table returns a series of 18 numeric values separated by commas. Each numeric value represents data displayed in the Authentication Data Table. Refer to the *HP 8924C Reference Guide*, Description of Fields, [Authentication Data Table](#) for description of each value and a programming example.

HP-IB Help

The CDMA Authentication Status Register provides status bits that can simplify remote operation.

For a full description of [CDMA Authentication Status Register](#) bits, refer to the *HP 8924C User's Guide*, Status Reporting.

HP-IB BASIC Programming Example Below is a program example that queries the CDMA Authentication Event Register to determine if a Unique Challenge is in progress, and if a Unique Challenge passed. This program assumes that the MSUT has registered or is on a call, and that the Test Set's SSD and the MSUT's SSD match.

```
10 ! RE-SAVE "c:\8924c\authentic\auth_status5"
20 ON TIMEOUT 7,10 GOTO 240
30 CLEAR 714
40 CLEAR SCREEN
50 OUTPUT 714;"DISP Caut"
60 OUTPUT 714;"*cls" !Clear out event bit registers
70 OUTPUT 714;"cdma:cell:conf:authenticate:mode 'on'" !Turn authentication on
80 OUTPUT 714;"cdma:auth:uch" !Initiate Unique Challenge-Response
90 LOOP
100 WAIT .5
110 OUTPUT 714;"stat:caut:even?"!Read CDMA Authentication Event Register
120 ENTER 714;Auth
130 !*****
140 IF BIT(Auth,2) THEN !Bit 1 is latched high when a Unique Challenge-Response begins
150 PRINT "Unique Challenge-Response in Progress..."
160 END IF
170 !
180 IF BIT(Auth,10) THEN !Bit 10 is latched high when a Unique Challenge passes
190 PRINT "Unique Challenge-Response passed"
200 END IF
210 !*****
220 EXIT IF Auth>=256 !Stop program when Unique Challenge passes
230 END LOOP
240 STOP
250 END
```

For a full description of CDMA Authentication Status Register bits, refer to the *HP 8924C User's Guide*, [Status Reporting](#).

4. Perform an MSUT-originated call.

Manual Operation:

1. Enter any phone number on the MSUT's keypad and press the SEND (or green) key.

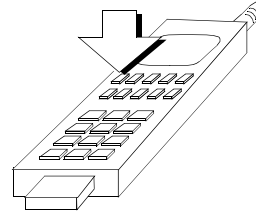

CDMA AUTHENTICATION

Call Status	Origination with Authen: Passed			
<input checked="" type="checkbox"/> Transmitting				
<input type="checkbox"/> Registering				
<input type="checkbox"/> Page Sent				
<input checked="" type="checkbox"/> Access Probe	Parameter	Expected	Received	Status
<input checked="" type="checkbox"/> Connected	AUTHR	2C594	2C594	Passed
<input type="checkbox"/> SSD Update	RANDC	34	34	Passed
<input type="checkbox"/> Unia Chall	COUNT	3	3	Passed
<input checked="" type="checkbox"/> SSD_A=0	AUTH_MODE	1	1	Passed

A_KEY	Check Digits	MS ID	To Screen
00000000000000000000	139763	Auto	<input checked="" type="checkbox"/> CDMA CALL CNTL SMS AUTHEN <input type="checkbox"/> Analog RX TEST Config TESTS

Authen <input checked="" type="checkbox"/> On/Off Timer Res <input checked="" type="checkbox"/> On/Off SSD Update Execute Unia Chall Execute	Authen Data Clear	Traffic Data Mode Svc Opt 1 Data Type Echo Echo Delay 2 Seconds	MS Database ESN B0000000
---	----------------------	---	--------------------------------

After Send (or green) is pressed on the MSUT, the Access Probe annunciator on the Test Set, will light to indicate that the mobile station sent an access probe sequence in an attempt to gain system access.

Some MSUT's require the number entered to be at least six digits long.

5. Perform the Unique Challenge.

Manual Operation:

- Select the Uniq Chall field.

Read the Unique Challenge on Traffic: message. It will indicate whether the unique challenge passed or failed.

Check the Authentication Data Table for AUTHU Pass/Fail results.

CDMA AUTHENTICATION

Unique Challenge on Traffic: Passed

Parameter	Expected	Received	Status
AUTHU	3084B	3084B	Passed

Call Status

Transmitting

Registering

Page Sent

Access Probe

Connected

SSD Update

Uniq Chall

SSD_A=0

A_KEY	Check Digits	MS ID	To Screen
00000000000000000000	174518	Auto	<input checked="" type="checkbox"/> CDMA <input type="checkbox"/> CALL CNTL <input type="checkbox"/> SMS <input type="checkbox"/> AUTHEN <input type="checkbox"/> Analog <input type="checkbox"/> RX TEST <input type="checkbox"/> Config <input type="checkbox"/> TESTS

Authen <input type="checkbox"/> On/Off Timer Res <input type="checkbox"/> On/Off SSD Update <input type="checkbox"/> Execute Uniq Chall <input type="checkbox"/> Execute	Authen Data <input type="checkbox"/> Clear	Traffic Data Mode <input type="checkbox"/> Svc Opt 1 Data Type <input type="checkbox"/> Echo Echo Delay <input type="checkbox"/> 2 Seconds	MS Database ESN B08197F4
---	---	--	--------------------------------

*If the Unique Challenge on Paging (or Traffic):
 Failed message appears, it means that AUTHU did not match the expected value.*

HP-IB Syntax

"CDMA:AUTH:DATA?" queries the results displayed in the Authentication Data Table.

HP-IB Help

Refer to **"HP-IB Help"** on page 233.

Measurement Overview

1. "Synchronize SSD between the Test Set and MSUT." on page 231.
2. "Select Unique Challenge." on page 232.
3. "Check the Authentication Data Table for results." on page 233.

It is recommended that you perform a Unique Challenge-Response after "Initializing SSD to Zero" on page 213 and after "Updating SSD" on page 222.

Short Message Service Tests

The following SMS tests verify that the Mobile Station Under Test (MSUT) is capable of receiving short messages.

Short messages can be sent:

- on the Paging/Access channels (phone has registered but is not on a traffic channel)
- on the Traffic channels (Service Option 6 or 14)
- on the Traffic channels (Service Option 1 or 32768)

All SMS procedures performed by the Test Set are mobile station terminated, meaning that the Test Set is sending messages to the MSUT.

The short message feature for the MSUT must be activated to perform these tests.

List of CDMA SMS Tests

"Sending Short Messages on the Paging/Access Channels" on page 241.

"Sending Short Messages on the Traffic Channels" on page 250.

Sending Short Messages on the Paging/Access Channels

This procedure sends a short message to the MSUT on the Paging channel. The Test Set verifies that the MSUT acknowledged receiving the SMS message.

1. Register the MSUT.

If the MSUT is already registered, this step is not necessary.

See "[Setting up a Call](#)" on page 52 if you are not familiar with how this procedure is performed with the Test Set.

.Registering the MSUT will ensure that it is monitoring the Test Set's Paging channel.

2. Optional: Clear (erase) old messages in the MSUT.

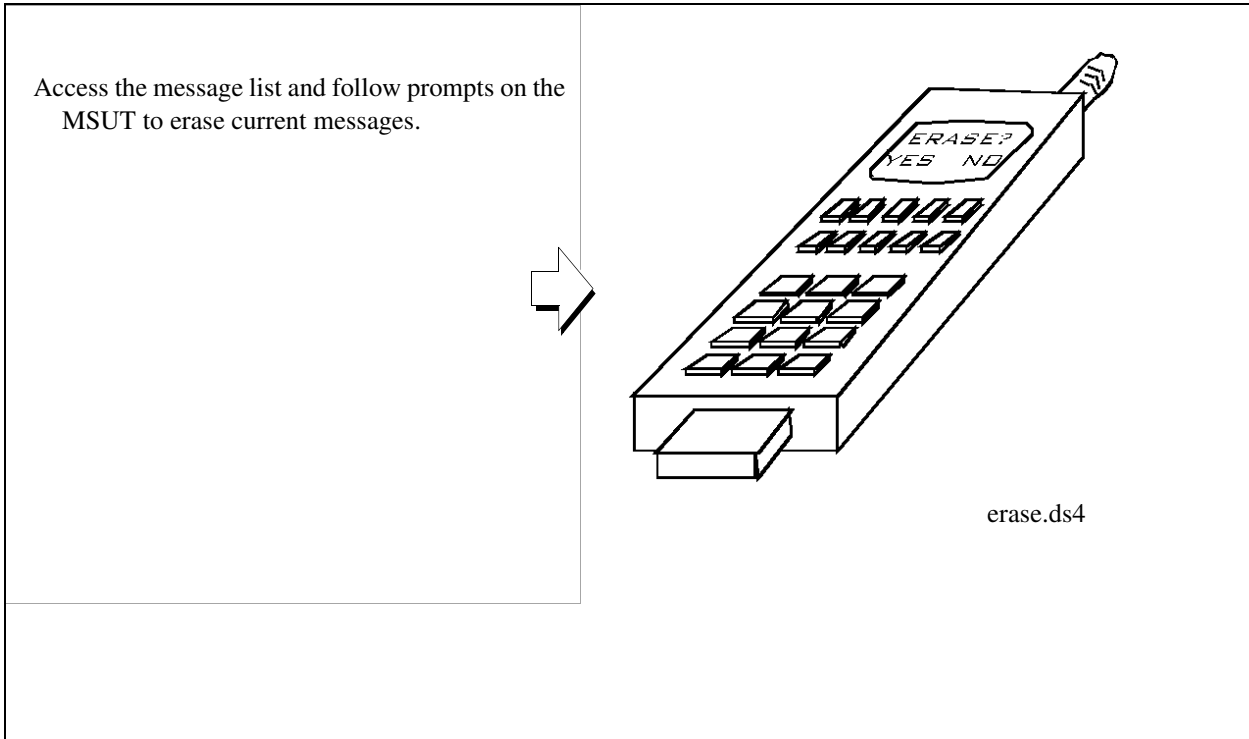

4. Enter a short message in the Test Set's data field.

<p>Manual Operation:</p> <ol style="list-style-type: none"> 1. Position the cursor in front of the data field shown. 2. Press the knob and enter a message. Select Done when done. 	<p style="text-align: right;">sms3.pcx</p>
---	--

HP-IB Syntax

"CDMA:SMS:TERM:DATA:ASC 'http://www.hp.com/go/tmdir'"

Enters a message in the User Data (ASCII) field.

5. Set the Page Rate.

Manual Operation:

1. Set the Page Rate field to Full.

CDMA SHORT MESSAGE SERVICE

Call Status
 Transmitting
 Page Sent
 Access Probe
 Connected
 SMS In Progress
 MS Ack Rcvd

User Data (ASCII):
 http://www.hp.com/go/twdir

MS Ack Cause Code:

Send Msg Execute	Alert On/Off	Data Mode ASCII	Traffic Data Mode	To Screen ● CDMA
	Priority None	Encoding 7-bit ASCII	Svc Opt 1 Data Type	CALL CNTL
	Privacy None	Duplicate User Data	Echo Echo Delay	SMS
	Orig Addr 9214001	Length 26 chars	MS Database ESN	AUTHEN
			0305426B Page Rate	○ Analog
			Full	RX TEST
				Config
				TESTS

sms8.pcx+newfield.pcx

Setting the Page Rate field to Full provides more Paging Channel slots to send the Data Burst Message in.

HP-IB Syntax

"CDMA:CELL:CONF:PAGE:RATE 'Full' "

enters "Full" in the Page Rate field.

6. Send the message.

Manual Operation:

1. Select the Send Msg Execute.

The SMS in Progress annunciator will light when the message is sent, and remain lit until an acknowledgment is received or SMS times out.

The MS Ack Rcvd will light when the Test Set has received an SMS Acknowledgment message from the MSUT.

CDMA SHORT MESSAGE SERVICE

Call Status

- Transmitting
- Page Sent
- Access Probe
- Connected
- SMS In Progress
- MS Ack Rcvd

User Data (ASCII):
 http://www.hp.com/go/tmdir

MS Ack Cause Code:

Send Msg Execute	Alert On/Off	Data Mode ASCII	Traffic Data Mode Svc Opt 1	To Screen CDMA
	Priority None	Encoding 7-bit ASCII	Data Type Echo	CALL CNTL SMS
	Privacy None	Duplicate User Data	Echo Delay 2 Seconds	RUTHEN
	Orig Addr 9214001	Length 26 chars	MS Database ESN	O Analog RX TEST
			D305426B Page Rate Full	Config TESTS

sms2.pcx+newfield.pcx

CDMA SHORT MESSAGE SERVICE

Call Status

- Transmitting
- Page Sent
- Access Probe
- Connected
- SMS In Progress
- MS Ack Rcvd

User Data (ASCII):
 http://www.hp.com/go/tmdir

MS Ack Cause Code:

Send Msg Execute	Alert On/Off	Data Mode ASCII	Traffic Data Mode Svc Opt 1	To Screen CDMA
	Priority None	Encoding 7-bit ASCII	Data Type Echo	CALL CNTL SMS
	Privacy None	Duplicate User Data	Echo Delay 2 Seconds	RUTHEN
	Orig Addr 9214001	Length 26 chars	MS Database ESN	O Analog RX TEST
			D305426B Page Rate Full	Config TESTS

sms4.pcx+newfield.pcx

HP-IB Syntax

"CDMA : SMS : TERM : SEND "

selects the Send Msg Execute field, which sends the message contained in the User Data field to the MSUT.

"STAT : CSMS : COND? "

queries the CDMA SMS Status Condition Register. Bit 0, (BCD 1) will be true while the SMS In Progress annunciator is lit.

"STAT : CSMS : EVEN? "

queries the CDMA SMS Status Event Register. Bit 1, (BCD 2) will be true after the MS Ack Rcvd light is lit.

Measurement Overview

1. "Register the MSUT." on page 242.
See "Setting up a Call" on page 52.
2. "Optional: Clear (erase) old messages in the MSUT." on page 243.
3. "Enter a short message in the Test Set's data field." on page 245.
4. "Set the Page Rate." on page 246.
5. "Send the message." on page 247.

Sending Short Messages on the Traffic Channels

This procedure sends a short message to the MSUT on the Traffic channels. The first message will be sent without setting up a call (Service Option 6 or 14), and the second message will be sent while the MSUT is on a call (Service Option 1 or 32768).

1. Register the MSUT.

If the MSUT is already registered, this step is not necessary.

See "[Setting up a Call](#)" on page 52 if you are not familiar with how this procedure is performed with the Test Set.

Registering the MSUT will ensure that it is monitoring the Test Set's Paging channel.

2. Optional: Clear (erase) old messages in the MSUT.

Access the message list and follow prompts on the MSUT to erase current messages.

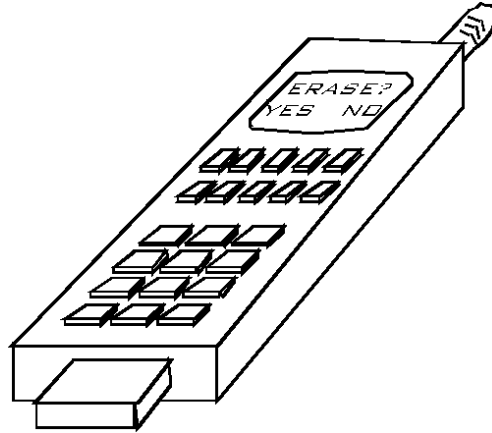

erase.ds4

3. Enter a short message in the Test Set's data field.

<p>Manual Operation:</p> <ol style="list-style-type: none"> 1. Select SMS from the To Screen, CDMA list. 2. Position the cursor in front of the data field shown. 3. Press the knob and enter a message. Select Done when done. 	<p>CDMA SHORT MESSAGE SERVICE</p> <p>Call Status <input checked="" type="checkbox"/> Transmitting <input type="checkbox"/> Page Sent <input type="checkbox"/> Access Probe <input type="checkbox"/> Connected <input type="checkbox"/> SMS In Progress <input type="checkbox"/> MS Ack Rcvd</p> <p>User Data (ASCII): HP TEST & MEASUREMENT http://www.hp.com/go/tmdir</p> <p>MS Ack Cause Code:</p> <table border="1"> <tr> <td>Send Msg Execute</td> <td>Alert On/Off Priority None Privacy None Orig Addr 9214001</td> <td>Data Mode ASCII Encoding 7-bit ASCII Duplicate User Data 1 times Length 48 chars</td> <td>Traffic Data Mode Suc Opt 1 Data Type Echo Echo Delay 2 Seconds MS Database ESN Page Rate Half</td> <td>To Screen ● CDMA CALL CNTL SMS AUTHEN ○ Analog RX TEST Config TESTS</td> </tr> </table>	Send Msg Execute	Alert On/Off Priority None Privacy None Orig Addr 9214001	Data Mode ASCII Encoding 7-bit ASCII Duplicate User Data 1 times Length 48 chars	Traffic Data Mode Suc Opt 1 Data Type Echo Echo Delay 2 Seconds MS Database ESN Page Rate Half	To Screen ● CDMA CALL CNTL SMS AUTHEN ○ Analog RX TEST Config TESTS
Send Msg Execute	Alert On/Off Priority None Privacy None Orig Addr 9214001	Data Mode ASCII Encoding 7-bit ASCII Duplicate User Data 1 times Length 48 chars	Traffic Data Mode Suc Opt 1 Data Type Echo Echo Delay 2 Seconds MS Database ESN Page Rate Half	To Screen ● CDMA CALL CNTL SMS AUTHEN ○ Analog RX TEST Config TESTS		

sms12.pcx

HP-IB Syntax

"CDMA:SMS:TERM:DATA:ASC 'HP TEST & MEASUREMENT http://www.hp.com/go/tmdir' "

Enters a message in the User Data (ASCII) field.

4. Send the message.

<p>Manual Operation:</p> <ol style="list-style-type: none"> 1. Select Svc Opt 6 or 14. 2. Press the CALL key. <p>The MS Ack Rcvd will light when the MSUT has sent an acknowledgment that it received the message.</p>	<p>CDMA SHORT MESSAGE SERVICE</p> <div style="border: 1px solid black; padding: 5px;"> <p>Call Status</p> <p><input checked="" type="checkbox"/> Transmitting</p> <p><input type="checkbox"/> Page Sent</p> <p><input type="checkbox"/> Access Probe</p> <p><input type="checkbox"/> Connected</p> <p><input checked="" type="checkbox"/> SMS In Progress</p> <p><input type="checkbox"/> MS Ack Rcvd</p> </div> <p>User Data (ASCII):</p> <div style="border: 1px solid black; padding: 2px;"> HP TEST & MEASUREMENT http://www .hp.com/go/tmdir </div> <p>MS Ack Cause Code:</p>																				
	<table border="1" style="width: 100%; border-collapse: collapse;"> <tr> <td style="width: 15%;">Send Msg Execute</td> <td style="width: 15%;">Alert On/Off</td> <td style="width: 15%;">Priority None</td> <td style="width: 15%;">Privacy None</td> <td style="width: 15%;">Orig Addr 9214001</td> <td style="width: 15%;">Encow 7-bit ASCII</td> <td style="width: 15%;">Duplicate User Data</td> <td style="width: 15%;">MS Database ESN D305426B Page Rate Full</td> <td style="width: 15%;">Traffic Data Mode Svc Opt 14</td> <td style="width: 15%;">To Screen <input checked="" type="radio"/> CDMA CALL CNTL SMS AUTHEN</td> </tr> <tr> <td></td> <td></td> <td></td> <td></td> <td></td> <td>times 1</td> <td>Length 26 chars</td> <td></td> <td></td> <td><input type="radio"/> Analog RX TEST Config TESTS</td> </tr> </table>	Send Msg Execute	Alert On/Off	Priority None	Privacy None	Orig Addr 9214001	Encow 7-bit ASCII	Duplicate User Data	MS Database ESN D305426B Page Rate Full	Traffic Data Mode Svc Opt 14	To Screen <input checked="" type="radio"/> CDMA CALL CNTL SMS AUTHEN						times 1	Length 26 chars			<input type="radio"/> Analog RX TEST Config TESTS
Send Msg Execute	Alert On/Off	Priority None	Privacy None	Orig Addr 9214001	Encow 7-bit ASCII	Duplicate User Data	MS Database ESN D305426B Page Rate Full	Traffic Data Mode Svc Opt 14	To Screen <input checked="" type="radio"/> CDMA CALL CNTL SMS AUTHEN												
					times 1	Length 26 chars			<input type="radio"/> Analog RX TEST Config TESTS												

sms5.pcx+newfield.pcx

Selecting Service Option 6 will select Rate Set 1 (9600 bps full rate).

Selecting Service Option 14 will select Rate Set 2 (14400 bps full rate).

HP-IB Syntax

"CDMA:CALL:TRAF:DATA:MODE 'Svc Opt 6' "

selects Service Option 6 in the Traffic Data Mode field.

"CDMA:SMS:TERM:SEND"

selects the Send Msg Execute field, which sends the message contained in the User Data field to the MSUT.

"STAT:CSMS:COND?"

queries the CDMA SMS Status Condition Register. Bit 0, (BCD 1) will be true while the SMS In Progress annunciator is lit.

"STAT:CSMS:EVEN?"

queries the CDMA SMS Status Event Register. Bit 1, (BCD 2) will be true after the MS Ack Rcvd light is lit.

5. Enter another short message in the Test Set's data field.

<p>Manual Operation:</p> <p>1. Position the cursor in front of the data field shown.</p> <p>3. Press the knob and enter the second message. Select Done when done.</p>	<p style="text-align: center;">CDMA SHORT MESSAGE SERVICE</p> <p>Call Status <input checked="" type="checkbox"/> Transmitting <input type="checkbox"/> Page Sent <input type="checkbox"/> Access Probe <input type="checkbox"/> Connected <input type="checkbox"/> SMS In Progress <input checked="" type="checkbox"/> MS Ack Rcvd</p> <p>User Data (ASCII): HP TEST & MEASUREMENT WEB SITE http://www.hp.com/go/tmdir</p> <p>MS Ack Cause Code:</p>				
	<p>Send Msg Execute</p>	<p>Alert On/Off</p> <p>Priority None</p> <p>Privacy None</p> <p>Orig Addr 9214001</p>	<p>Data Mode ASCII</p> <p>Encoding 7-bit ASCII</p> <p>Duplicate User Data</p> <p>1 times</p> <p>Length 26 chars</p>	<p>Traffic Data Mode Svc Opt 14</p> <p>MS Database ESN D305426B Page Rate Full</p>	<p>To Screen <input checked="" type="checkbox"/> CDMA CALL CNTL SMS AUTHEN</p> <p><input type="checkbox"/> Analog RX TEST</p> <p>Confis TESTS</p>

sms6.pcx+newfield.pcx

HP-IB Syntax

"CDMA:SMS:TERM:DATA:ASC 'HP TEST & MEASUREMENT WEB SITE http://www.hp.com/go/tmdir' "

Enters a message in the User Data (ASCII) field.

6. Make a call.

<p>Manual Operation:</p> <ol style="list-style-type: none"> 1. Select Svc Opt 1 or 32768. 2. Press the CALL key. 3. When the MSUT rings, press the SEND (or green) key on the MSUT's keypad to connect the call. <p>The Connected annunciator must be lit before proceeding to the next step.</p>	<p style="text-align: center;">CDMA SHORT MESSAGE SERVICE</p> <p>Call Status <input checked="" type="checkbox"/> Transmitting <input checked="" type="checkbox"/> Page Sent <input checked="" type="checkbox"/> Access Probe <input checked="" type="checkbox"/> Connected <input type="checkbox"/> SMS In Progress <input checked="" type="checkbox"/> MS Ack Rcvd</p> <p>User Data (ASCII): HP TEST & MEASUREMENT WEB SITE http://www.hp.com/go/tmdir</p> <p>MS Ack Cause Code:</p> <table border="1"> <tr> <td>Send Msg Execute</td> <td>Alert On/Off Priority None Privacy None Orig Addr 9214001</td> <td>Data Mode Svc Opt 1 Data Type Echo Echo Delay 2 Seconds MS Database ESN D305426B Page Rate Full</td> <td>To Screen ● CDMA CALL CNTL SMS AUTHEN ○ Analog RX TEST Config TESTS</td> </tr> </table> <p style="text-align: right;">sms7.pcx+newfield.pcx</p>	Send Msg Execute	Alert On/Off Priority None Privacy None Orig Addr 9214001	Data Mode Svc Opt 1 Data Type Echo Echo Delay 2 Seconds MS Database ESN D305426B Page Rate Full	To Screen ● CDMA CALL CNTL SMS AUTHEN ○ Analog RX TEST Config TESTS
Send Msg Execute	Alert On/Off Priority None Privacy None Orig Addr 9214001	Data Mode Svc Opt 1 Data Type Echo Echo Delay 2 Seconds MS Database ESN D305426B Page Rate Full	To Screen ● CDMA CALL CNTL SMS AUTHEN ○ Analog RX TEST Config TESTS		

HP-IB Syntax

"CDMA:CALL:TRAF:DATA:MODE 'Svc Opt 1'"

selects Service Option 1 in the Traffic Data Mode field.

"CDMA:CALL:MAKE"

Attempts a call by paging the MSUT. This is the same function performed by pressing the **CALL** key on the Test Set's front panel.

Measurement Overview

1. "Register the MSUT." on page 251.
See "Setting up a Call" on page 52.
2. "Optional: Clear (erase) old messages in the MSUT." on page 252.
3. "Enter a short message in the Test Set's data field." on page 253.
4. "Send the message." on page 254.
5. "Enter another short message in the Test Set's data field." on page 255.
6. "Make a call." on page 256.
7. "Send the message." on page 257.

Establishing HP-IB Communication

Setting Up HP-IB Control

The Test Set should have power turned on.

1. Connect the HP-IB Cable if you are using an external controller.

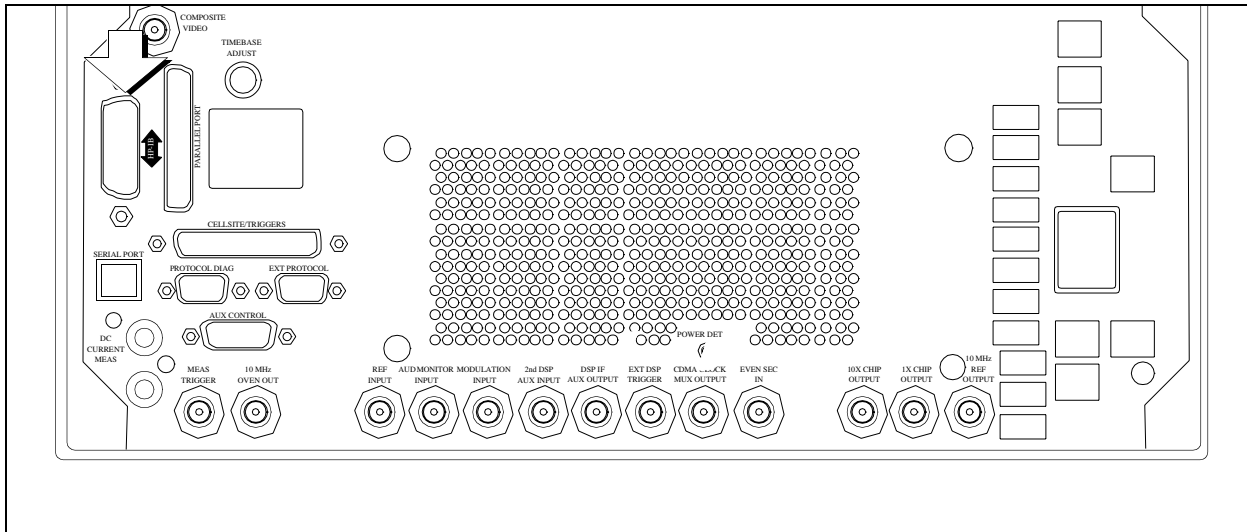

2. Check the Test Set's HP-IB address if you are using an external controller.

Manual Operation:

Press and release the SHIFT key, and then the LOCAL key to display the Test Set's current HP-IB address setting. The address will display at the top of the CRT.

If this address is not what is needed go to next step.

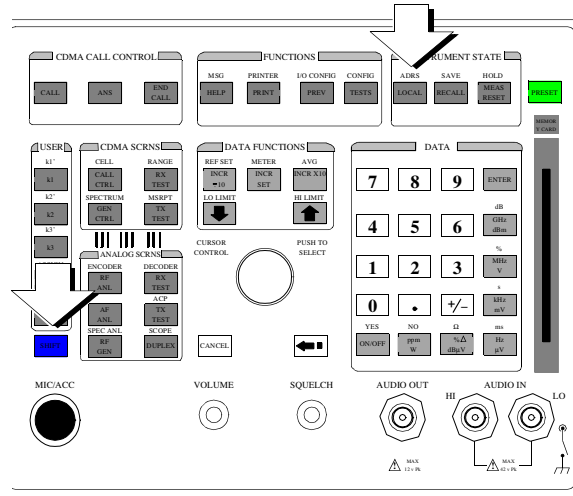

3. Change the Test Set's HP-IB Address if necessary.

Manual Operation:

1. Press and release the SHIFT key, and then the PREV (I/O CONFIG) key to display the HP-IB address
2. Position cursors at HP-IB Adrs field.
3. Use DATA keys to enter the address.

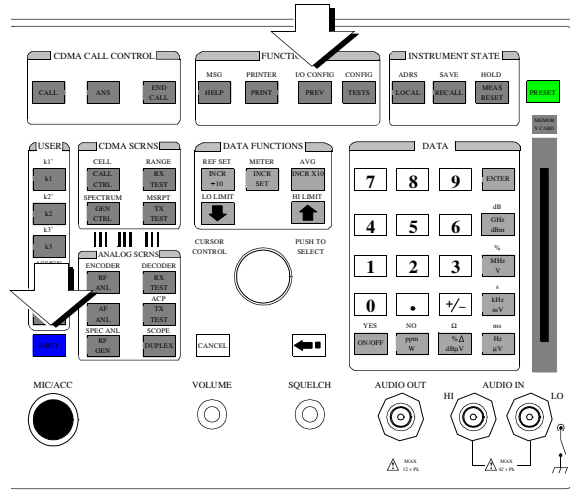

64 Using the Analog Call Processing Subsystem

Description of the Analog Call Processing Subsystem

The Analog Call Processing Subsystem, which comprises six call processing screens, simulates an analog cellular base station. The Analog Call Processing Subsystem provides, through host firmware control, the specific signals and protocol messages necessary to automatically establish and maintain a cellular link between the Test Set (simulated base station) and a cellular phone (mobile station).

Once the link is established the operator can exercise the call processing functionality of the mobile station, such as

- decoding orders from the base station, such as orders to retune the transceiver to a new channel, to alert the mobile station user to an incoming call, to adjust the transceiver output power level, or to release the mobile station upon completion of a call.
- encoding signaling information for transmission to the base station, such as dialed digits for call origination, disconnect signal at the completion of a call, or mobile identification number.

In addition to exercising the mobile station's call processing functions, the Test Set automatically

- measures some of the basic RF characteristics of the mobile station's transmitted carrier, such as; transmitter power, frequency accuracy and modulation deviation
- decodes and displays various reverse control channel and reverse voice channel signaling messages

For forward control channel and forward voice channel signaling messages, the operator has the option of sending messages whose contents are built using the rules and regulations specified in the applicable industry standard, or the operator can define the message contents as desired. Having the capability to set the bit patterns of the signaling messages sent to the mobile station gives the operator the capability to test the robustness of the mobile station by introducing known errors into the signaling message.

Operational Overview

The Test Set is able to simulate a cellular base station by using its hardware and firmware resources to initiate and maintain a link with only one mobile station. Unlike a real base station, which has many transceivers and can support many mobile stations simultaneously, the Test Set has only one transceiver (it's signal generator and RF/AF analyzer) and can support only one mobile station at a time. This means that the Test Set's transceiver can be configured as either a control channel or a voice channel, but not both simultaneously.

To establish a link with a mobile station the Test Set's transceiver is configured as a control channel. Once a link has been established and the user wishes to test the mobile station on a voice channel, the Test Set sends the appropriate information to the mobile station on the control channel and then automatically re-configures it's transceiver to the voice channel assigned to the mobile station. Once the voice channel link is terminated the Test Set automatically re-configures it's transceiver back to being a control channel.

Analog to analog handoffs are accomplished in a similar manner. When a handoff is initiated while on a voice channel, the Test Set sends the necessary information to the mobile station on the current voice channel. At the proper time the Test Set then automatically re-configures it's transceiver to the new voice channel.

Figure 1, "Call Processing State Diagram," on page 266 illustrates the primary call processing functions available in the Analog Call Processing Subsystem. Each box represents a call processing state and includes the measurement information available while in that state. The events which trigger transitions between the various states are shown on the diagram. Events which are initiated from the Test Set are shown in solid lines and events which are initiated from the mobile station are shown in dashed lines. The annunciators on the call processing screens will be lit while in that call processing state.

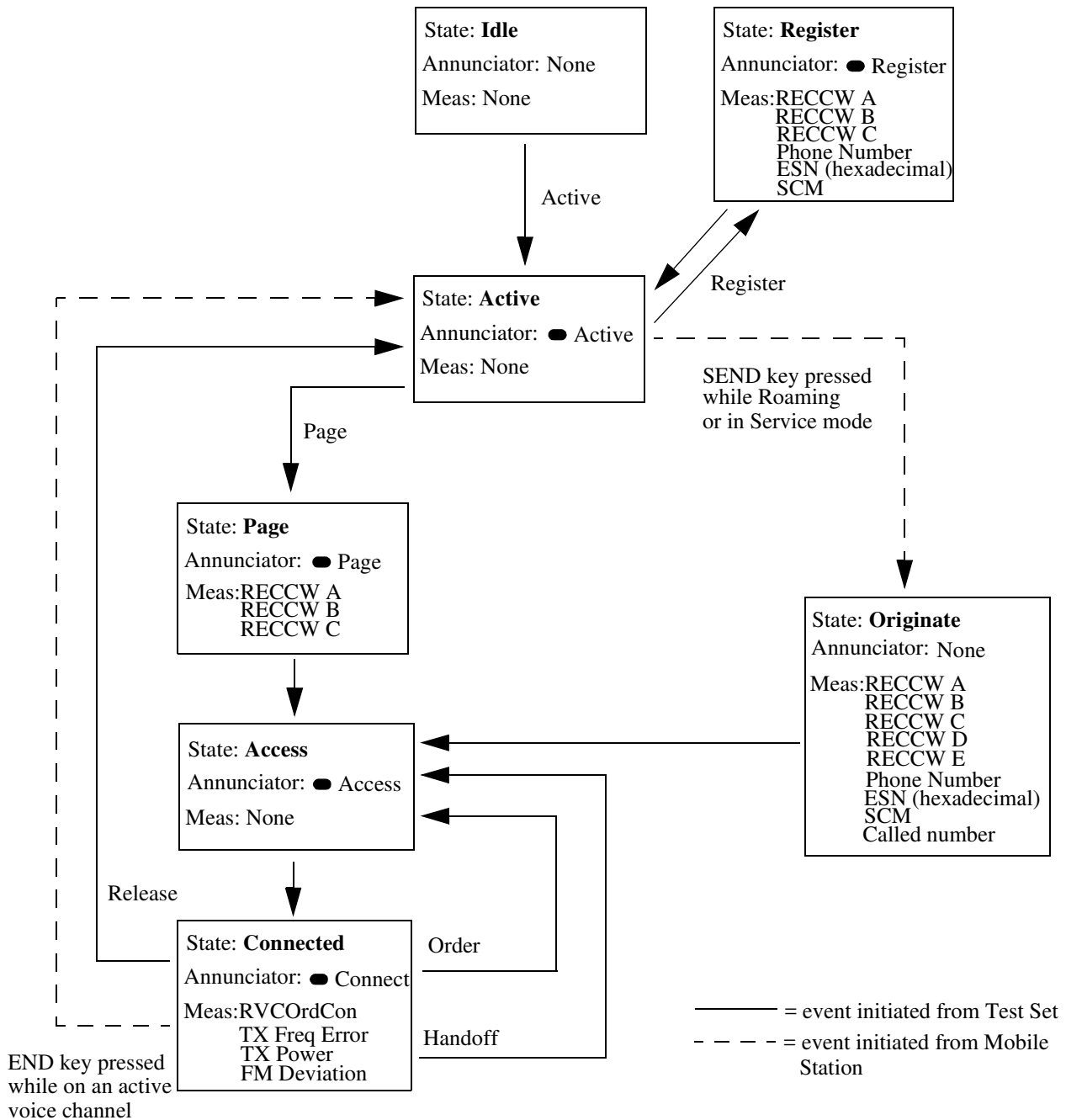

Figure 1 Call Processing State Diagram

Accessing the Analog Call Processing Subsystem Screens

The Analog Call Processing Subsystem screens are accessed by selecting the **CALL CNTL** screen under the **To Screen**, Analog menu on the CRT of the Test Set or by pressing then releasing the SHIFT key, then pressing the RF ANL key under ANALOG SCRNS.

Analog Call Processing Subsystem Screens

The Analog Call Processing Subsystem consists of six screens.

- **CALL CONTROL** is the primary Analog Call Processing Subsystem screen. This screen contains the fields used to configure the simulated base station parameters such as SAT Tone frequency, control channel number, system identification number, etc. Call processing functions such as registration, page, handoff, etc. can be activated from this screen. The transmit power of the mobile station can be set from this screen. Data messages received from the mobile station are displayed on this screen.
- **CALL DATA** screen displays the decoded signaling messages received from the mobile station on the reverse control channel and the reverse voice channel. Call processing functions such as registration, page, handoff, etc. can also be activated from this screen. The transmit power of the mobile station can be set from this screen.
- **CALL BIT** screen allows the advanced user to modify the contents of the forward control channel and forward voice channel messages used in a call processing messaging protocol (that is - the sequence of messages sent from the simulated base station to the mobile station to perform a desired action).
- **CALL CONFIGURE** screen contains the fields used to configure various parameters related to the Analog Call Processing Subsystem.
- **ANALOG MEAS** screen is used to make analog RF and audio measurements on the mobile station while a link is active.

Using Manual (Front-Panel) Control

In order to use the Analog Call Processing Subsystem a mobile station must be connected to the Test Set and be powered on.

Connecting A Mobile Station

Figure 2, "Connecting a Mobile Station to the Test Set," on page 269 shows a typical example of connecting a mobile station to the Test Set. Many of today's small, handheld mobile stations require special fixtures, available from the mobile station manufacturer, to access the antenna, audio in and audio out on the mobile station.

If any audio testing is to be done on the mobile station, the audio input (microphone input) to the mobile station and the audio output (speaker output) from the mobile station must be connected to the Test Set. If no audio testing is to be done only the antenna needs to be connected to the Test Set.

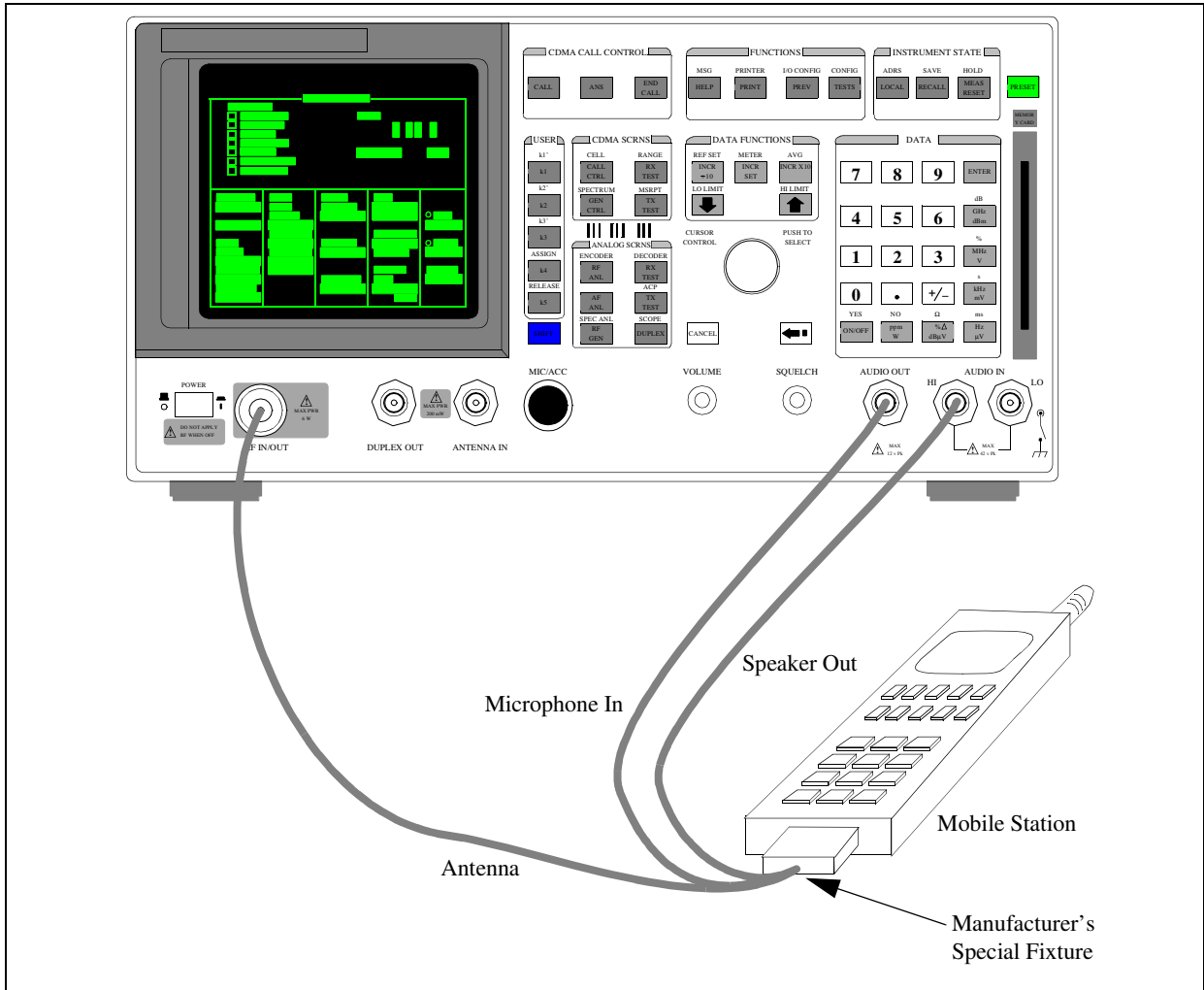

Figure 2 Connecting a Mobile Station to the Test Set

NOTE: Do not connect the antenna of the mobile station to the ANT IN port on the front panel of the Test Set; this will cause the overpower protection circuitry to trip when the mobile station is transmitting. .

Mobile Station Audio Out Impedance

If the mobile station's speaker is disconnected when using the manufacturer's special fixture, the user must ensure that the proper load impedance is applied to the audio output of the mobile station. The special fixtures supplied by the manufacturer of the mobile station may or may not terminate the audio output in its proper load impedance. Refer to the manufacturer's documentation for information on the termination supplied by the special fixture.

If a load impedance must be supplied then it can be placed across the AUDIO IN connector.

600 Ohm Impedance Some industry standards require the audio out of the mobile station to be terminated in 600 ohms for testing purposes. The AUDIO IN connector of the Test Set can be terminated in 600 ohms internally.

Generalized Test Procedure

This section presents a generalized which can be followed to successfully use the Analog Call Processing Subsystem. This procedure does not exercise all the functionality of the Analog Call Processing Subsystem. The procedure exercises the mobile station as follows:

- registers the mobile station
- pages the mobile station
- brings the mobile station up on a voice channel
- hands the mobile station off to a new voice channel
- makes a 12 dB SINAD measurement on the mobile station while on a voice channel (if the mobile station's audio in/out connections are available)
- releases the mobile station

Procedure:

1. Press the PRESET key to preset the Test Set.
2. Select **CALL CNTL** from the **To Screen** menu.
3. Select **CALL CNFG** from the **To Screen** menu.
4. Disconnect any cables from the RF IN/OUT port on the front panel of the Test Set.
5. Select the **TX Pwr Zero** field.

When any Analog Call Processing Subsystem screen is displayed (except the ANALOG MEAS screen) and the Analog Call Processing Subsystem is in the connected state (**Connect** annunciator is lit), the host firmware constantly monitors the mobile station's transmitted carrier power. If the power falls below 0.0005 Watts the error message **RF Power Loss indicates loss of Voice Channel** will be displayed and the simulated base station will terminate the call and return to the active state (**Active** annunciator is lit). Zeroing the power meter cancels any inherent dc offsets that may be present within the power meter under zero power conditions. This ensures that the host firmware makes the correct decisions regarding the presence of the mobile stations's RF carrier.

6. Press and release the blue SHIFT key and then the DUPLEX key to display the CON-FIGURE screen.
7. Position the cursor on the **Notch Coupl** field and select **AFGen1**.

This couples the variable frequency notch filter to the output frequency of **AFGen1** (audio frequency generator #1). The notch filter is used when making the SINAD measurement. **AFGen1** is used to generate the audio tone for the SINAD measurement. Coupling the notch filter to the audio source ensures the most accurate measurement.

8. Connect the mobile station to the Test Set as shown in [figure 2 on page 269](#).
9. Turn the mobile station on.
10. Position the cursor on **CALL CNTL** under the **To Screen** menu and select it. The CALL CONTROL screen will be displayed.
11. Verify that the simulated base station configuration information is correct for the mobile station to be tested. Check the following fields:
 - a **System Type**
 - b **Cntl Channel**
 - c **SID**
 - d **Chan:** (right-hand subfield)
 - e **Pwr Lvl:** (right-hand subfield)
 - f **SAT:** (right-hand subfield)

12. Position the cursor next to the **Active** field and select it. The **Active** annunciator will light when the control channel is turned on.

NOTE:

If the **Cntl Channel** field or the **System Type** field were modified in step 11.a. or b. the control channel will already be active since modifying these fields automatically activates the control channel.

13. Position the cursor next to the **Register** field and select it. The **Register** annunciator will light while the registration is in process. If the mobile station responds properly on the reverse control channel the message **RECC Return** will flash momentarily in the upper right-hand corner of the CALL CONTROL screen and the mobile station phone number, ESN and decoded SCM will be displayed in the upper right-hand portion of the CALL CONTROL screen. The information in the **MS Id** field will be updated. The **Active** annunciator will light when the registration has successfully completed.

Position the cursor next to the **Page** field and select it. The **Page** annunciator will light while the simulated base station pages the mobile on the forward control channel. If the mobile station responds properly on the reverse control channel the message **RECC Return** will flash momentarily in the upper right-hand corner of the CALL CONTROL screen. The **Access** annunciator will then light while the simulated base station sends the mobile station an alert order on the assigned voice channel. The mobile station should ring. Press the SEND key on the mobile station. The **Connect** annunciator will light if the mobile station properly signals the simulated base station when the SEND key is pressed. The mobile station is now connected to the simulated base station on the assigned voice channel. The left-hand subfields in the **Voice Channel Assignment** section will be updated with the voice channel assignment information (that is - the “-” will be replaced with appropriate information).

14. Position the cursor on the **Display** field and select the **Meas** display. The upper right-hand portion of the CALL CONTROL screen will display modulation quality measurements of the mobile station’s RF carrier. The Test Set’s data functions, such as the average (**AVG**) function, can be used with any of the measurements. Measurement units can also be changed as desired.
15. Position the cursor on the **Order** field and select it. A **Choices:** menu is displayed showing the various power levels which the mobile station can be set to. Position the cursor next to the desired power level and select it. The simulated base station will then signal the mobile station with an order to set it’s power level. If the mobile responds properly the measured value in the **TX Power** field will change.
16. Position the cursor on the **Display** field and select the **Data** display.

17. Position the cursor on the **Order** field and select it. A **Choices:** menu is displayed showing the various power levels which the mobile station can be set to. Position the cursor next to the desired power level and select it. The **Access** annunciator will light while the simulated base station signals the mobile station with an order to set its power level. If the mobile responds properly the message **REVC Return** will flash momentarily in the upper right-hand corner of the CALL CONTROL screen and the decoded order confirmation message received from the mobile station will be displayed in the upper right-hand portion of the CALL CONTROL screen. The left-hand **Pwr Lvl:** subfield in the **Voice Channel Assignment** section will be updated with the new power level information.
18. Position the cursor on the **Chan:** field in the **Voice Channel Assignment** section and select it. Enter a new, valid voice channel number.
19. Position the cursor on the **Pwr Lvl:** field in the **Voice Channel Assignment** section and select it. Enter a new, valid mobile station power level.
20. Position the cursor on the **SAT:** field in the **Voice Channel Assignment** section and select it. Enter a new, valid SAT frequency.

Position the cursor on the **Handoff** field and select it. The **Access** annunciator will light while the simulated base station signals the mobile station with the handoff information. If the mobile responds properly it will stop transmitting on the current voice channel, switch to the new voice channel assignment and transpond the new SAT frequency assignment. When the simulated base station detects that this has happened, the **Connect** annunciator is lit indicating that the handoff was successful. The left-hand subfields in the **Voice Channel Assignment** section will be updated with the new voice channel assignment information.

21. Position the cursor on the **ANLG MEAS** field under the **To Screen** menu and select it. The ANALOG MEAS screen will be displayed.

NOTE:

The mobile station's speaker output must be connected to the Test Set's AUDIO IN connector and the mobile station's microphone input must be connected to the Test Set's AUDIO OUT connector in order to use the ANALOG MEAS screen. If the mobile station does not have audio connections go to 24.

22. There are many measurements which can be made on the mobile station from the ANALOG MEAS screen. The following example illustrates how to make a SINAD measurement.
 - a Position the cursor on the **AFGen1 To** lower subfield and set it to 8 kHz.
 - b Position the cursor on the **AF An1 In** field and select **Audio In**.
 - c Position the cursor on the **Filter 1** field and select **C MESSAGE**.
 - d Position the cursor on the **Filter 2** field and select **>99kHz LP**.
 - e Position the cursor on the **Detector** field and select **PK+**.
 - f Position the cursor on the **AF Freq** measurement field and select **SINAD**.
 - g Position the cursor on the **Amplitude** field and begin to lower the transmitted base station voice channel power until 12 dB SINAD is reached.

NOTE:

The mobile station might mute or drop off the air before a 12 dB SINAD is reached. The performance of the mobile station at low RF levels is dependent upon the characteristics of the mobile station (that is - what type of system it is designed for). Unlike a real base station, the simulated base station does not perform any protocol functions on the voice channel.

-
23. Position the cursor on the **CALL CNTL** field under the **To Screen** menu and select it. The **CALL CONTROL** screen will be displayed.
 24. Position the cursor on the **Release** field and select it. The simulated base station will signal the mobile station with a release order. The mobile station will respond to the release order and cease transmission. The simulated base station will terminate transmission on the forward voice channel and the **Connect** annunciator will turn off. The simulated base station will then reconfigure itself for transmission on the forward control channel, begin to transmit system parameter overhead messages and the **Active** annunciator will light.

Description of the Call Processing Subsystem's Remote User Interface

The Call Processing Subsystem's Remote User Interface consists of the following items:

- a set of programming commands which access all available fields on the six Call Processing Subsystem screens
- a status register group whose condition register reflects the current state of the Call Processing Subsystem annunciator state indicators
- a set of error messages, available through HP-IB, which provide information about error conditions encountered while in the Call Processing Subsystem

The programming commands provide the capability to generate control programs which can establish a cellular link between the Test Set (simulated Base Station) and a cellular phone (mobile station). The status register group and the error messages provide the control program with the information necessary to make program flow decisions.

Once a link is established the control program can exercise the call processing functionality of the mobile station, such as:

- the decoding of orders from the Base Station, such as; orders to retune the transceiver to a new frequency, to alert the mobile station user to an incoming call, to adjust the transceiver output power level, or to release the mobile station upon completion of a call.
- the encoding of signaling information for transmission to the base station, such as; dialed digits for call origination, disconnect signal at the completion of a call, or mobile identification number.
- the authentication signaling associated with AMPS (IS-54) call processing such as shared secret data update, unique challenge, origination with authentication and page with authentication.

In addition to the mobile station's call processing functions, the control program can utilize the RF and audio instruments in the Test Set to characterize the overall performance of the mobile station while on an active voice channel by making such measurements as; receiver sensitivity, FM Hum & Noise, transmitter carrier power, carrier frequency accuracy, SAT tone deviation, etc.

The Call Processing Subsystem decodes various reverse control channel and reverse voice channel signaling messages. The remote user interface provides commands which allow the control program access to the contents of the decoded messages.

For forward control channel and forward voice channel signaling messages, the Call Processing Subsystem provides the option of sending messages whose contents are built using the rules and regulations specified in the applicable industry standard, or the control program can define the message contents as desired. Having the capability to set the bit patterns of the signaling messages sent to the mobile station gives the control program the capability to test the robustness of the mobile station by introducing known errors into the signaling messages. Once an error has been introduced the control program can monitor the response of the mobile station.

Operational Overview

The Test Set simulates a cellular base station by using its hardware and firmware resources to initiate and maintain a link with a mobile station. Unlike a real base station, the Test Set has only one transceiver (its signal generator and RF/AF analyzer) and can support only one mobile station at a time. This means that the Test Set's transceiver can be configured as either a control channel or a voice channel, but not both simultaneously.

To establish a link with a mobile station the Test Set's transceiver is configured as a control channel. Once a link has been established and the user wishes to test the mobile station on a voice channel, the Test Set sends the appropriate information to the mobile station on the control channel and then automatically re-configures its transceiver to the voice channel assigned to the mobile station. Once the voice channel link is terminated, the Test Set automatically re-configures its transceiver back to being a control channel.

Handoffs are accomplished in a similar manner. When a handoff is initiated while on a voice channel, the Test Set sends the necessary information to the mobile station on the current voice channel. At the proper time, the Test Set automatically re-configures its transceiver to the new voice channel.

See "[Call Processing State Diagram](#)" on page 266 illustrates the primary call processing functions available in the Call Processing Subsystem. Each box represents a call processing state and includes the measurement information available while in that state. Each box also includes the name of the annunciator on the call processing screen that will be lit while in that call processing state. Events which trigger transitions between the various states are shown on the diagram. Events which are initiated from the Test Set are shown in solid lines and events which are initiated from the mobile station are shown in dashed lines.

Using Remote (HP-IB) Control

In order to use the Analog Call Processing Subsystem remotely, a mobile station must be connected to the Test Set and be powered on.

Accessing the Call Processing Subsystem Screens

The Call Processing Subsystem screens are accessed by selecting the **CALL CONTROL**, **CALL DATA**, **CALL BIT**, **CALL CONFIGURE**, **ANALOG MEAS**, or **AUTHENTICATION** screens using the :DISPlay command. The mnemonics used to select a particular screen with the **DISPlay** command are shown in HP-IB Command Syntax chapter of the *HP 8924C Condensed Programming Reference Guide*.

The Call Processing Subsystem screens are accessed by selecting the **CALL CONTROL**, **CALL DATA**, **CALL BIT**, **CALL CONFIGURE**, or **ANALOG MEAS** screens using the :DISPlay command. The mnemonics used to select a particular screen with the DISPlay command are shown in [table 4](#).

The query form of the :DISPlay command (that is, :DISPlay?) can be used to determine which screen is currently displayed.

Table 4 Call Processing Screen Mnemonics

Screens	Mnemonic
CALL CONTROL	ACNT
CALL DATA	CDAT
CALL BIT	CBIT
CALL CONFIGURE	CCNF
ANALOG MEAS	CME
AUTHENTICATION	AUTH

Syntax

```
:DISPlay <screen mnemonic>  
:DISPlay?
```

Example

```
OUTPUT 714;"DISP ACNT"  
OUTPUT 714;"DISP?"  
ENTER 714;Screen$
```

Command Syntax

The Analog Call Processing Subsystem programming commands and command syntax for [CALL Process](#) are detailed in HP-IB Command Syntax chapter of the *HP 8924C Condensed Programming Reference Guide*. Examples of command usage are found in this section.

CAUTION:

The *OPC, *OPC? and *WAI commands should *not* be used for determining if a Call Processing Subsystem state command has completed successfully. Call Processing Subsystem states do not complete, a state is either active or not active. Using the *OPC, *OPC? or *WAI commands with a Call Processing Subsystem state command results in a deadlock condition.

Refer to the descriptions of the deadlock conditions for *OPC, *OPC? and *WAI commands are provided in HP-IB Common Commands chapter of the *HP 8924C Condensed Programming Reference Guide*.

The *OPC, *OPC? or *WAI commands should not be used with any of the following Call Processing Subsystem commands: :ACTive, :REGister, :PAGE, :HANDoff, :RELease.

The Call Processing Subsystem Status Register Group should be used to control program flow.

Conditioning the Test Set for Call Processing

It is recommended that the control program perform the following steps when first entering the Analog Call Processing Subsystem (that is - the first time the **CALL CONTROL** screen is selected during a measurement session).

- Zero the RF Power meter.

There are two reasons for zeroing the RF power meter:

- a When any Analog Call Processing Subsystem screen is displayed (except the ANALOG MEAS screen) and the Analog Call Processing Subsystem is in the **Connect** state, the host firmware constantly monitors the mobile station's transmitted carrier power. If the power falls below 0.0005 Watts the error message **RF Power Loss indicates loss of Voice Channel** will be displayed and the simulated base station will terminate the call and return to the **Active** state. Zeroing the power meter cancels any inherent dc offsets that may be present within the power meter under zero power conditions. This ensures that the host firmware makes the correct decisions regarding the presence of the mobile stations's RF carrier.
- b Zeroing the power meter establishes a 0.0000 W reference for measuring the mobile station's RF power at the RF IN/OUT port. This ensures the most accurate RF power measurements of the mobile stations's RF carrier at different power levels.

Example

```
OUTPUT 714; "RFG:AMPL:STATE OFF"  
OUTPUT 714; "DISP RFAN; :RFAN:PME:ZERO"  
OUTPUT 714; "RFG:AMPL:STATE ON"
```

NOTE:

Ensure that no RF power is applied to the **RF IN/OUT** port when the power meter is being zeroed.

- Couple the variable frequency notch filter to AFGen1.

This step is only required if audio testing is to be done on the mobile station. This step couples the variable frequency notch filter to the output frequency of AFGen1 (audio frequency generator #1). The notch filter is used when making SINAD measurements. AFGen1 is used to generate the audio tone for the SINAD measurement. Coupling the notch filter to the audio source ensures the most accurate measurement.

Commands:

```
OUTPUT 714; "DISP CONF; :CONF:NOTC 'AFGEN1' "
```

Analog Call Processing Subsystem HP-IB Error Messages

The Analog Call Processing Subsystem HP-IB error messages are numbered 1300 through 1317. See the “[Error Messages](#)” chapter in the *HP 8924C User's Guide* for details.

Reading An Analog Call Processing Subsystem HP-IB Error Messages

If an error occurs while in the Analog Call Processing Subsystem, an appropriate error message will be placed in the Error Message Queue. The control program can read the Error Message Queue to retrieve the error message.

See “[Error Message Queue](#)” in the Status Reporting chapter of the *HP 8924C User's Guide* for detailed information.

If an error occurred while attempting to decode data messages received from the mobile station on the reverse control channel or reverse voice channel, the raw data message bits are displayed in hexadecimal format in the upper right hand portion of the CALL CONTROL screen.

Figure 3 on page 281 shows layout of the CALL CONTROL screen when a decoding error has occurred. The raw data bits can be read by the control program.

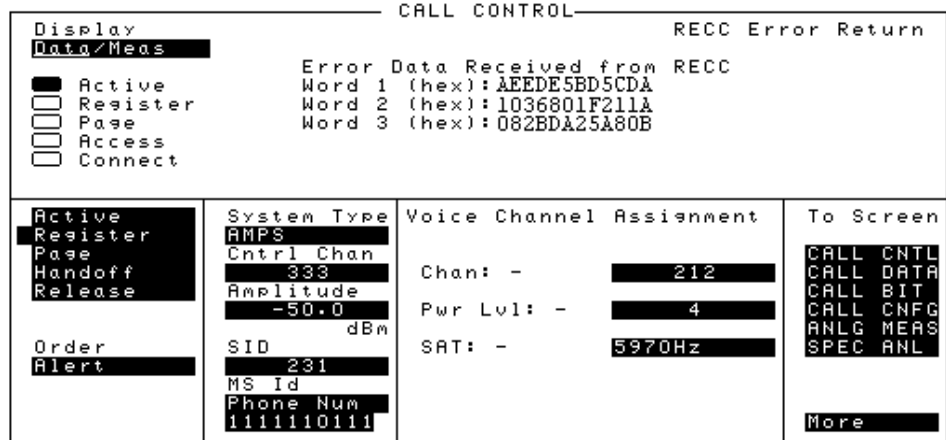

Figure 3 CALL CONTROL Screen with Decoding Error Message Display

Call Processing Status Register Group

See “Analog Call Processing Subsystem Status Register Group” in the Status Reporting chapter of the *HP 8924C User’s Guide* for a detailed description.

Using the Call Processing Status Register Group To Control Program Flow

The Analog Call Processing Subsystem uses annunciators to indicate its current state. That is - if the Analog Call Processing Subsystem is in the connected state, the **Connect** annunciator will be lit.

Bits 0 through 5 of the Condition register in the Call Processing Status Register Group mirror the condition of the annunciators. That is - if the **Connect** annunciator is lit, bit 5 of the Condition register will be TRUE, logic 1, and all other bits will be FALSE, logic 0.

Under most circumstances a control program will need some means of determining the state of an interaction between itself (the control program), the Analog Call Processing Subsystem and the mobile station.

For example - if the control program wishes to register a mobile station, it (the control program) will have to send a command to put the Analog Call Processing Subsystem into the **Active** state, then, once in the **Active** state, send a registration message by putting the Analog Call Processing Subsystem into the

Register state and then determine when to read the mobile station's registration information in order to make a determination as to whether the mobile station registered correctly.

In the manual user interface, the annunciators supply this state information to the operator. In the remote user interface, the Call Processing Status Register Group supplies the state information to the control program.

The control program can access this information in one of two ways; by [polling](#) the status registers or by using the [service request](#) feature of the HP-IB. If properly implemented, either method can be used to obtain the information. Refer to Status Reporting chapter of the *HP 8924C User's Guide*.

When To Query Data Messages Received From The Mobile Station

The Analog Call Processing Subsystem makes available to the control program many data messages received from the mobile station. For example - if the simulated Base Station sends a registration message to the mobile station, the registration information (MIN, ESN, SCM) received from the mobile station can be read by the control program.

The data messages are displayed on the CRT *after* the successful completion of the call processing function (registration, page, origination, etc.). When call processing functions complete, state changes occur within the Analog Call Processing Subsystem. For example - when a registration completes the Analog Call Processing Subsystem exits the register state (the **Register** annunciator is turned off) and returns to the active state (the **Active** annunciator is turned on).

The control program should only query the Test Set for the data messages *after* all the state transitions are complete. For example - the control program should not attempt to read the MIN, ESN or SCM until after the **Register** annunciator is turned off and the **Active** annunciator is turned on.

This is because the Test Set has a multi-tasking architecture wherein multiple processes execute on a priority driven and an event driven basis. Each process is given a timeslice on the CPU depending upon its priority, the priority of other processes and the nature of the events occurring within the Test Set.

Upon completion, processes within the Analog Call Processing Subsystem pass data messages received from the mobile station to the Measurement Display Process which displays the information on the CRT during its next CPU timeslice. If the control program attempts to query the data fields before the Measurement Display Process has posted the information to the CRT, it is possible that the fields will be blank or contain data from a previous call processing function.

Waiting to read the data messages until after all state transitions have occurred ensures that the data from the most recent call processing function will have been posted. **Table 5, "Analog Call Processing Subsystem State Transitions" on page 284** lists the possible state transitions within the Analog Call Processing Subsystem.

Table 5 Analog Call Processing Subsystem State Transitions

Starting State	Command	State Transitions	Final State
Idle	Active	Idle - Active	Active
Active	Register	Active - Register - Active	Active
Active	Page	Active -Page - Access - Connect	Connect
Connect	Handoff	Connect - Access - Connect	Connect
Connect	Release	Connect - Active	Active
Connect	Order	Connect - Access - Connect	Connect
Any state	Active	Current state - Active	Active

NOTE:

The **Access** state may occur more than once during state transitions. For example: Connect - Access - Access - Connect. The number of times the **Access** state occurs is situation and system dependent.

If, for some specific application need, it is necessary to query the data messages before all state transitions have occurred, the control program may have to wait some finite amount of time before requesting the data or request the data multiple time (checking for the presence of data each time) or some combination of the two.

Analog Call Processing Subsystem state changes can be monitored by the control program through the Call Processing Status Register Group.

See “[Call Processing Status Register Group](#)” in Status Reporting chapter of the *HP 8924C User’s Guide* for a detailed description of the Analog Call Processing Subsystem Status Register Group.

Using the CALL CONTROL Screen to Test Call Processing Functions

The CALL CONTROL screen provides multiple functions for testing a mobile station. The following sections describe how to:

Conditioning the Test Set for Call Processing

Perform the following steps when first entering the Call Processing Subsystem (that is, the first time the CALL CONTROL screen is selected during a measurement session).

- c Zero the RF Power Meter.
- d Select the **RF GEN** from the **To Screen** menu.
- e Set the **Amplitude** field to off (use the ON/OFF key). This prevent cross-coupling into the power detector while zeroing the power meter.
- f Select **CALL CNTL** from the **To Screen** menu.
- g Select **CALL CNFG** from the **To Screen** menu.
- h Disconnect any cables from the RF IN/OUT port on the front panel of the Test Set.
- i Select the **TX Pwr Zero** field.
- j Select the **RF Gen** from the To Screen menu.
- k Set the **Amplitude** field to On.

There are two reasons for zeroing the RF power meter:

- When any Call Processing Subsystem screen is displayed (except the ANALOG MEAS screen) and the Call Processing Subsystem is in the connected state (**Connect** annunciator is lit), the Test Set constantly monitors the mobile station's transmitted carrier power. If the power falls below 0.0005 Watts, the error message **RF Power Loss indicates loss of Voice Channel** will be displayed and the Test Set will terminate the call and return to the active state. Zeroing the power meter cancels any inherent dc offsets that may be present within the power meter under zero-power conditions. This ensures that the Test Set makes the correct decisions regarding the presence of the mobile stations's RF carrier.
- Zeroing the power meter establishes a 0.0000 W reference for measuring the mobile station's RF power at the RF IN/OUT port. This ensures the most accurate RF power measurements of the mobile station's RF carrier at different power levels.

- 1 Couple the variable-frequency notch filter to AFGen1.

This step is only required if audio testing is to be done on the mobile station. This step couples the variable-frequency notch filter to the output frequency of AFGen1 (audio frequency generator1). The notch filter is used when making SINAD measurements. AFGen1 is used to generate the audio tone for the SINAD measurement. Coupling the notch filter to the audio source ensures the most accurate measurement.

- a Press and release the blue SHIFT key and then the DUPLEX key to display the CONFIGURE screen.
- b Position the cursor on the **Notch Coupl** field and select **AFGen1**.

Configure the Test Set

1. Select **CALL CNTL** from the **To Screen** menu. The CALL CONTROL screen will be displayed.
2. Verify that the Test Set configuration information is appropriate for the mobile station to be tested. Check the following fields:
 - a **system Type** - Select the type of cellular system to be simulated (AMPS, NAMPS, TACS, JTACS).

NOTE:

If the **System Type** field was modified in step 2.a. the control channel will become active since modifying this field automatically activates the control channel. Refer to the “Call Control Screen” chapter in the *HP 8924C Reference Guide*.

- b **system Type** - Select the type of cellular system to be simulated (AMPS, TACS, JTACS).

NOTE:

If the **System Type** field was modified in step 2. a. the control channel will become active since modifying this field automatically activates the control channel. Refer to the “Call Control Screen” chapter in the *HP 8924C Reference Guide*.

- c **Cntl Channel** - Set the control channel number to be used by the Test Set.

NOTE:

If the **Cntl Channel** field was modified in step 2. c the control channel will become active since modifying this field automatically activates the control channel. Refer to the “Call Control Screen” chapter in the *HP 8924C Reference Guide*.

- d **Amplitude** - Set the output power of the Test Set’s transmitter (that is, the output power of the Test Set’s RF Generator).
- e **SID** - Enter the system identification number of the Test Set as a decimal number.
- f **Chan:** (right-hand field) - Enter the voice channel number which will be assigned to the mobile station by the Test Set as either an initial voice channel assignment or as a handoff voice channel assignment.

- g Ch Loc:** (right-hand field, **NAMPS** system type only) - Select the narrow analog channel location which will be assigned to the mobile station by the Test Set as either an initial channel location assignment or as a handoff channel location assignment. The choices are Lower (10 kHz below standard wide analog channels), Middle (centered at the wide analog channel), Upper (10 kHz above the standard analog channel) or Wide Chan.
 - h Pwr Lvl:** (right-hand field) - Enter the Voice Mobile Attenuation Code (VMAC). The VMAC determines the mobile station power level to be used on the voice channel.
 - i DSAT:** (right-hand field, **NAMPS** system type only) - Select the DSAT Color Code (DSCC) to be used on the voice channel
- SAT:** (right-hand field) - Enter the SAT frequency to be used on the voice channel.
3. Select **CALL CNFG** from the **To Screen** menu. The CALL CONFIGURATION screen will be displayed.
 4. Verify that the Test Set's configuration information is appropriate for the mobile station to be tested. Check the following fields:
 - a CMAX** - Set the number of access channels in the system. This will determine how many channels must be scanned by the mobile station when trying to access the Test Set. The value of this field will affect the time required for the mobile station to connect with the Test Set.

Turn On The Test Set's Control Channel

1. If not already done, condition the Test Set. See "[Conditioning the Test Set for Call Processing](#)" on page 279 for further information.
2. If not already done, configure the Test Set. See "[Configure the Test Set](#)" on page 286 for further information.
3. If the CALL CONTROL screen is not displayed, select **CALL CNTL** from the **To Screen** menu. The CALL CONTROL screen will be displayed.
4. Select the **Active** field. The **Active** annunciator will light when the control channel is turned on.

Register a Mobile Station

1. Ensure that the Test Set is in the active state. See "[Turn On The Test Set's Control Channel](#)" on page 287 for information on how to activate the Test Set.
2. Connect the mobile station to the Test Set as shown in [Figure 2, "Connecting a Mobile Station to the Test Set,"](#) on page 269.
3. Turn on the mobile station.
4. If the CALL CONTROL screen is not displayed, select **CALL CNTL** from the **To Screen** menu. The CALL CONTROL screen will be displayed.
5. Position the cursor on the **Display** field and select **Data**.

6. Select the **Register** field. The **Register** annunciator will light while the registration is in process. If the mobile station responds properly on the reverse control channel, the message **RECC Return** will flash momentarily in the upper right-hand corner of the CALL CONTROL screen and the mobile station phone number, ESN and decoded SCM will be displayed in the upper right-hand portion of the CALL CONTROL screen. The information in the **MS Id** field will be updated. The **Active** annunciator will light when the registration has successfully completed.

Page a Mobile Station

There are two methods that can be used to page a mobile station:

- Page a mobile station that [has registered](#) with the Test Set.
- Page a mobile station that [has not registered](#) with the Test Set.

Paging a Mobile Station that has Registered with the Test Set

1. Ensure that the Test Set is in the active state. [See "Turn On The Test Set's Control Channel" on page 287](#) for information on how to activate the Test Set.
2. Connect the mobile station to the Test Set as shown in [figure 2, "Connecting a Mobile Station to the Test Set," on page 269](#).
3. Turn on the mobile station.
4. If the CALL CONTROL screen is not displayed, select **CALL CNTL** from the **To screen** menu. The CALL CONTROL screen will be displayed.
5. Position the cursor on the **Display** field and select **Data**.
6. Ensure that the mobile station has registered with the Test Set. [See "Register a Mobile Station" on page 287](#) for information on how to register the mobile station.
7. Select the **Page** field. The **Page** annunciator will light while the Test Set pages the mobile on the forward control channel. If the mobile station responds properly on the reverse control channel, the message **RECC Return** will flash momentarily in the upper right-hand corner of the CALL CONTROL screen. The **Access** annunciator will then light while the Test Set sends the mobile station an alert order on the assigned voice channel. The mobile station should ring.
8. Press the SEND key on the mobile station. The **Connect** annunciator will light if the mobile station properly signals the Test Set when the SEND key is pressed. The mobile station is now connected to the Test Set on the assigned voice channel. The voice channel assignment section will be updated: that is, any "-" in the left-hand fields will be replaced with appropriate information.

Paging a Mobile Station That Has Not Registered with the Test Set

1. Ensure that the Test Set is in the active state. [See "Turn On The Test Set's Control Channel" on page 287](#) for information on how to activate the Test Set.
2. Connect the mobile station to the Test Set as shown in
3. [Figure 2, "Connecting a Mobile Station to the Test Set," on page 269](#)
4. Turn on the mobile station.
5. If the CALL CONTROL screen is not displayed, select **CALL CNTL** under the **To screen** menu. The CALL CONTROL screen will be displayed.
6. Position the cursor on the **Display** field and select **Data**.

7. Select the lower **MS Id** field. Enter the mobile station identification number, either the phone number or the MIN number depending upon what the upper **MS Id** field is set to.
8. Select the **Page** field. The **Page** annunciator will light while the Test Set pages the mobile on the forward control channel. If the mobile station responds properly on the reverse control channel, the message **RECC Return** will flash momentarily in the upper right-hand corner of the CALL CONTROL screen. The **Access** annunciator will then light while the Test Set sends the mobile station an alert order on the assigned voice channel. The mobile station should ring.
9. Press the SEND key on the mobile station. The **Connect** annunciator will light if the mobile station properly signals the Test Set when the SEND key is pressed. The mobile station is now connected to the Test Set on the assigned voice channel. The **Voice Channel Assignment** fields will be updated: that is, any “-” in the left-hand fields will be replaced with appropriate information.

Handoff a Mobile Station to a New Voice Channel

1. Ensure that the Test Set is in the connect state. See ["Page a Mobile Station" on page 288](#) for information on how to bring a mobile station up on a voice channel.
2. If the CALL CONTROL screen is not displayed, select **CALL CNTL** from the **To Screen** menu. The CALL CONTROL screen will be displayed.
3. Position the cursor on the **Display** field and select **Data**.
4. Select the **Chan:** field. Enter a new, valid voice channel number.
5. Select the **Ch Loc:** field (**NAMPS** system type only). Enter a new, valid channel location from the **Choices:** menu.
6. Select the **Pwr Lvl:** field. Enter a new, valid mobile station power level.
7. Select the **DSAT:** field (**NAMPS** system type only). Enter a new, valid DSAT from the **Choices:** menu.
8. Select the **SAT:** field. Enter a new, valid SAT frequency.
9. Select the **Handoff** field. The **Access** annunciator will light while the Test Set signals the mobile station with the handoff information. If the mobile responds properly, it will stop transmitting on the current voice channel, switch to the new voice channel, and transpond the newly assigned SAT frequency. When the Test Set detects this has happened the **Connect** annunciator is lit indicating that the handoff was successful. The **Voice Channel Assignment** section will be updated; that is, any “-” in the left-hand fields will be replaced with appropriate information.

Release A Mobile Station

1. Ensure that the Test Set is in the connected state. See ["Page a Mobile Station" on page 288](#) for information on how to bring a mobile station up on a voice channel.
2. If the CALL CONTROL screen is not displayed, select **CALL CNTL** from the **To Screen** menu. The CALL CONTROL screen will be displayed.

3. Select the **Release** field. The Test Set will signal the mobile station with a release order. The mobile station will respond to the release order and cease transmission. The Test Set will terminate transmission on the forward voice channel, and the **Connect** annunciator will turn off. The Test Set will then reconfigure itself for transmission on the forward control channel, begin to transmit system parameter overhead messages, and the **Active** annunciator will light.

Change the Transmit Power Level of a Mobile Station

1. Ensure that the Test Set is in the connected state. See "[Page a Mobile Station](#)" on [page 288](#) for information on how to bring a mobile station up on a voice channel.
2. If the CALL CONTROL screen is not displayed, select **CALL CNTL** from the **To Screen** menu. The CALL CONTROL screen will be displayed.
3. Position the cursor on the **Display** field and select **Meas**. The upper right-hand portion of the CALL CONTROL screen will display modulation quality measurements of the mobile station's RF carrier. The Test Set's data functions, such as the average (AVG) function, can be used with any of the measurements. Measurement units can also be changed as desired.
4. Select the **Order** field and select it. A **Choices:** menu is displayed showing the various power levels which the mobile station can be set to. Select the desired power level from the **Choices:** menu. The Test Set will then signal the mobile station with an order to set its power level. If the mobile responds properly, the measured value in the **TX Power** field will change.
5. Position the cursor on the **Display** field and select **Data**.
6. Select the **Order** field. Select the desired power level from the **Choices:** menu. The **Access** annunciator will light while the Test Set signals the mobile station with an order to set its power level. If the mobile responds properly, the message **REVC Return** will flash momentarily in the upper right-hand corner of the CALL CONTROL screen and then the decoded order confirmation message received from the mobile station will be displayed. The left-hand **Pwr Lvl:** field will be updated with the new power level information. The **Connect** annunciator will light when signaling is complete.

Originate a Call from a Mobile Station

1. Ensure that the Test Set is in the active state. See "[Turn On The Test Set's Control Channel](#)" on [page 287](#) for information on how to activate the Test Set.
2. Connect the mobile station to the Test Set as shown in
3. [Figure 2, "Connecting a Mobile Station to the Test Set," on page 269](#)
4. Turn on the mobile station.
5. If the CALL CONTROL screen is not displayed, select **CALL CNTL** from the **To Screen** menu. The CALL CONTROL screen will be displayed.
6. Position the cursor on the **Display** field and select **Data**.

7. Dial the desired phone number on the mobile station and press the SEND key on the mobile station's handset. The mobile station signals the Test Set on the reverse control channel with an origination message which includes the dialed phone number, the mobile station's MIN number and the mobile station's ESN. If the mobile station transmitted properly on the reverse control channel, the message **RECC Return** will flash momentarily in the upper right-hand corner of the CALL CONTROL screen and then the mobile station phone number, ESN, decoded SCM, and the called phone number will be displayed. The Test Set will then reconfigure itself to the voice channel assignments set up in the **Voice Channel Assignment** section of the CALL CONTROL screen. The **Access** annunciator will then light while the Test Set signals the mobile station on the assigned voice channel. The **Connect** annunciator will light if the mobile station properly signals the Test Set on the reverse voice channel. The mobile station is now connected to the Test Set on the assigned voice channel. The left-hand fields will be replaced with appropriate information.

Send an Alert Order to a Mobile Station

1. Ensure that the Test Set is in the connected state. See "[Page a Mobile Station](#)" on [page 288](#) for information on how to bring a mobile station up on a voice channel.
2. If the CALL CONTROL screen is not displayed, select **CALL CNTL** under the **To Screen** menu. The CALL CONTROL screen will be displayed.
3. Select the **Order** field. A **Choices:** menu is displayed showing the various orders which can be sent to the mobile station. Select the **Mainten** order from the list of choices. The Test Set will then go into the **Access** state and signal the mobile station with a maintenance order. If the mobile station is responding properly it will go into its maintenance state as defined by the applicable cellular system standard. The left-hand fields in the **Voice Channel Assignment** section will display a '-' while the Test Set is in the access state.
4. Select the **Order** field. A **Choices:** menu is displayed showing the various orders which can be sent to the mobile station. Position the cursor next to the **Alert** order and select it. The Test Set will then signal the mobile station with an alert order. If the mobile station is responding properly it will alert (that is, it will ring). Press the SEND key on the mobile station to respond to the alert order. The mobile station should exit the maintenance state. The Test Set, upon detecting that the mobile station has exited the maintenance state, will return to the **Connect** state and the left-hand subfields in the **Voice Channel Assignment** section will be updated with the current voice channel assignment information.

NOTE:

Applicable cellular system standards may specify a time-out period for the maintenance state. If an Alert order is not received during this time-out period the mobile station may take some action as defined by the standard. One such action might be to terminate the voice channel connection. Refer to the applicable cellular system standard for specific information

Using the CALL CONTROL Screen to test AMPS Authentication

The process of testing AMPS authentication (IS-54) through the Call Processing Subsystem requires the user to synchronize the base station and mobile station. This synchronization requires that the base station and the mobile station possess two pieces of shared secret data (SSD) to confirm a valid call. The first piece is the **ESN** of the mobile station and the second piece is the mobile station's **A-key**. The A-key is a secret 26-digit number stored in the mobile station's semi-permanent memory. The following sections describe how to:

- Condition the Test Set for Call Processing with Authentication
- Configure the Test Set for authentication
- Turn On The Test Set's Control Channel
- Initialize Call Processing with Authentication
- Page a Mobile Station with Authentication
- Originate a Call with Authentication
- Perform an SSD Update
- Perform a Unique Challenge

Condition the Test Set for Call Processing

Perform the following steps when first entering the Call Processing Subsystem (that is, the first time the CALL CONTROL screen is selected during a measurement session).

- 1 Zero the RF Power Meter.
 - a Select the **RF Gen** from the **To Screen** menu.
 - b Set the **Amplitude** field to off (use the ON/OFF key) This prevents cross-coupling into the power detector while zeroing the power meter.
 - c Select **CALL CNTL** from the **To Screen** menu.
 - d Select **CALL CNFG** from the **To Screen** menu.
 - e Disconnect any cables from the RF IN/OUT port on the front panel of the Test Set.
 - f Select the **TX Pwr Zero** field.

There are two reasons for zeroing the RF power meter:

- When any Call Processing Subsystem screen is displayed (except the ANALOG MEAS screen) and the Call Processing Subsystem is in the connected state (**Connect** annunciator is lit), the Test Set constantly monitors the mobile station's transmitted carrier power. If the power falls below 0.0005 Watts, the error message **RF Power Loss indicates loss of Voice Channel** will be displayed and the Test Set will terminate the call and return to the active state. Zeroing the power meter cancels any inherent dc offsets that may be present within the power meter under zero-power conditions. This ensures that the Test Set makes the correct decisions regarding the presence of the mobile stations's RF carrier.
- Zeroing the power meter establishes a 0.0000 W reference for measuring the mobile station's RF power at the RF IN/OUT port. This ensures the most accurate RF power measurements of the mobile station's RF carrier at different power levels.

2 Couple the variable-frequency notch filter to AFGen1.

This step is only required if audio testing is to be done on the mobile station. This step couples the variable-frequency notch filter to the output frequency of AFGen1 (audio frequency generator 1). The notch filter is used when making SINAD measurements. AFGen1 is used to generate the audio tone for the SINAD measurement. Coupling the notch filter to the audio source ensures the most accurate measurement.

- a Press and release the blue SHIFT key and then the DUPLEX key to display the CONFIGURE screen.
- b Position the cursor on the **Notch Coupl** field and select **AFGen1**.

Configure the Test Set

1. Select **CALL CNTL** from the **To Screen** menu. The CALL CONTROL screen will be displayed.
2. Verify that the Test Set configuration information is appropriate for the mobile station to be tested. Check the following fields:
 - a **System Type** - Select AMPS. At this time, only AMPS is supported for authentication.

NOTE:

If the **System Type** field was modified in step 2. a. the control channel will become active since modifying this field automatically activates the control channel. Refer to the "Call Control Screen" chapter in the *HP 8924C Reference Guide*.

- b **Cnt1 Channel** - Set the control channel number to be used by the Test Set.

NOTE:

If the **Cnt1 Channel** field was modified in step 2. b. the control channel will become active since modifying this field automatically activates the control channel. Refer to the "Call Control Screen" chapter in the *HP 8924C Reference Guide*.

- c **Amplitude** - Set the output power of the Test Sets's transmitter (that is, the output power of the Test Set's RF Generator).

- d **SID** - Enter the system identification number of the Test Set as a decimal number.
 - e **Chan:** (right-hand field) - Enter the voice channel number which will be assigned to the mobile station by the Test Set as either an initial voice channel assignment or as a handoff voice channel assignment.
 - f **Pwr Lvl:** (right-hand field) - Enter the Voice Mobile Attenuation Code (VMAC). The VMAC determines the mobile station power level to be used on the voice channel.
 - g **SAT:** (right-hand field) - Enter the SAT frequency to be used on the designated voice-channel.
3. Select **CALL CNFG** under the **To Screen** menu. The CALL CONFIGURATION screen will be displayed.
 4. Verify that the Test Set's configuration information is appropriate for the mobile station to be tested. Check the following field:
 - a **CMAx** - Set the number of access channels in the system. This will determine how many channels must be scanned by the mobile station when trying to access the Test Set. The value of this field will affect the time required for the mobile station to connect with the Test Set.

Turn on the Test Set's Control Channel

1. If not already done, condition the Test Set. See "[Conditioning the Test Set for Call Processing](#)" on page 279 for further information.
2. If not already done, configure the Test Set. See "[Configure the Test Set](#)" on page 286. for further information.
3. If the CALL CONTROL screen is not displayed, select **CALL CNTL** from the **To Screen** menu. The CALL CONTROL screen will be displayed.
4. Select **Active** field. The **Active** annunciator will light when the control channel is turned on.

Initialize Call Processing with Authentication

There are two methods to initialize Call Processing with authentication.

- Initializing Call Processing with Authentication [through registration](#) with the Test Set.
- Initializing Call Processing with Authentication [without registration](#) with the Test Set.

Initialize Call Processing through Registration

1. Ensure that the Test Set is in the active state. See "[Turn On The Test Set's Control Channel](#)" on page 287 .
 1. for information on how to activate the Test Set.
 2. Connect the mobile station to the Test Set as shown in [figure 2, "Connecting a Mobile Station to the Test Set,"](#) on page 269.
 3. Turn on the mobile station.
 4. If the CALL CONTROL screen is not displayed, select **CALL CNTL** under the **To Screen** menu. The CALL CONTROL screen will be displayed.
 5. Position the cursor on the **Display** field and select **Data**.

6. Select the **Register** field. The **Register** annunciator will light while the registration is in process. If the mobile station responds properly on the reverse control channel, the message **RECC Return** will flash momentarily in the upper right-hand corner of the CALL CONTROL screen and then the mobile station's phone number, ESN and decoded SCM will be displayed in the upper right-hand portion of the CALL CONTROL screen. The information in the **MS Id** field will be updated. The **Active** annunciator will light when the registration has successfully completed.
7. Select **AUTHEN** on the To Screen field. The AUTHENTICATION screen will be displayed.
8. Select the **A_KEY** field and enter a valid A_KEY in decimal format.
9. Position the cursor on the **Off/On** field and select **On**.
10. Select **CALL CNTL** from the **To Screen** menu. The CALL CONTROL screen will be displayed.
11. Select **SSD Upd** in the **CC Order** field. The Access annunciator light will light while the SSD Update order is in progress. If the mobile station responds properly on the reverse control-channel, "**SSD Update Order Successful**" will be displayed in the upper right-hand portion of the CALL CONTROL screen. The test set and the mobile station now share common secret data and further call processing functions with authentication can be tested. If the order failed, then "**SSD Update Order Failed**" will appear on the upper right-hand portion of the CALL CONTROL screen.

Initializing Authentication without Registration

1. Ensure that the Test Set is in the active state. See "**Turn On The Test Set's Control Channel**" on page 287.
 1. for information on how to activate the Test Set.
 2. Connect the mobile station to the Test Set as shown in **figure 2, "Connecting a Mobile Station to the Test Set,"** on page 269.
 3. Turn on the mobile station.
 4. If the CALL CONTROL screen is not displayed, select **CALL CNTL** from the **To Screen** menu. The CALL CONTROL screen will be displayed.
 5. Position the cursor on the **Display** field and select **Data**.
 6. Select the upper **MS ID** field and then select **MIN2 MIN1** from the Choices: menu.
 7. Select the lower **MS ID** field and enter the information in hexadecimal format.
 8. Select **AUTHEN** from the To Screen menu. The AUTHENTICATION screen will be displayed.
 9. Select the A_KEY field and enter a valid A_KEY in decimal format.
 10. Select the ESN field and enter the mobile station's electronic serial number in a hexadecimal format.
 11. Position the cursor on the **Off/On** field and select **On**.
 12. Select **CALL CNTL** from the **To Screen** menu. The CALL CONTROL screen will be displayed.

13. Select **SSD Upd** from the **CC Order** field. The Access annunciator light will light while the SSD Update order is in progress. If the mobile station responds properly on the reverse control-channel, "**SSD Update Order Successful**" will be displayed in the upper right-hand portion of the CALL CONTROL screen. The test set and the mobile station now share common secret data and further call processing functions with authentication can be tested. If the order failed, then "**SSD Update Order Failed**" will appear on the upper right-hand portion of the CALL CONTROL screen.

Page a Mobile Station with Authentication

Paging A Mobile Station That Has Registered With The Test Set

1. Ensure that the Test Set is in the active state. See "[Turn On The Test Set's Control Channel](#)" on page 287 for information on how to activate the Test Set.
2. Connect the mobile station to the Test Set as shown in [Figure 2, "Connecting a Mobile Station to the Test Set,"](#) on page 269.
3. Turn on the mobile station.
4. If the CALL CONTROL screen is not displayed, select **CALL CNTL** from the **To Screen** menu. The CALL CONTROL screen will be displayed.
5. Position the cursor on the **Display** field and select **Data**.
6. Ensure that the mobile station has registered with the Test Set. See "[Initialize Call Processing with Authentication](#)".
7. for information on how to register the mobile station.
8. Select the **Page** field. The **Page** annunciator will light while the Test Set pages the mobile on the forward control channel. If the mobile station responds properly on the reverse control-channel the message **RECC Return** will flash momentarily in the upper right-hand corner of the CALL CONTROL screen. The **Access** annunciator will then light while the Test Set sends the mobile station an alert order on the assigned voice channel. The mobile station should ring.
9. Press the SEND key on the mobile station. The **Connect** annunciator will light if the mobile station properly signals the Test Set. The mobile station is now connected to the Test Set on the assigned voice channel. The **Voice Channel Assignment** fields will be updated, that is, any "-" in the left-hand fields will be replaced with appropriate information. If page with authentication was successful, "**Page w/Auth successful**" will be displayed in the upper right-hand portion of the CALL CONTROL screen. If page with authentication failed, then "**Page w/Auth failed**" will be displayed in the upper right-hand portion of the CALL CONTROL Screen.

Originate a Call with Authentication

1. Ensure that the Test Set is in the active state. See "[Turn on the Test Set's Control Channel](#)".
2. Connect the mobile station to the Test Set as shown in [Figure 2, "Connecting a Mobile Station to the Test Set,"](#) on page 269.
3. Turn on the mobile station.
4. If the CALL CONTROL screen is not displayed, select **CALL CNTL** under the **To Screen** menu. The CALL CONTROL screen will be displayed.

5. Position the cursor on the **Display** field and select **Data**.
6. Ensure that the mobile station has registered with the Test Set. See "[Initialize Call Processing with Authentication](#)" for information on how to register the mobile station.
7. Dial the desired phone number on the mobile station and press the SEND key on the mobile station's handset. The mobile station signals the Test Set on the reverse control channel with an origination message which includes the dialed phone number, the mobile station's MIN number and the mobile station's ESN. If the mobile station transmitted properly on the reverse control channel, the message **RECC Return** will flash momentarily in the upper right-hand corner of the CALL CONTROL screen and then the mobile station's phone number, ESN, decoded SCM, and called phone number will be displayed. The Test Set will then reconfigure itself to the voice channel assignments set up in the **Voice Channel Assignment** section of the CALL CONTROL screen. The **Access** annunciator will then light while the Test Set signals the mobile station on the assigned voice channel. The **Connect** annunciator will light if the mobile station properly signals the Test Set on the reverse voice channel. The mobile station is now connected to the Test Set on the assigned voice channel. The **Voice Channel Assignment** fields will be replaced with appropriate information. If origination with authentication was successful, then "**Origination w/Auth successful**" will be displayed in the upper right-hand portion of the CALL CONTROL screen. If origination with authentication failed, then "**Origination w/Auth failed**" will be displayed in the upper right-hand portion of the CALL CONTROL Screen.

Perform an SSD Update

There are two methods that can be used to perform an SSD Update:

- SSD Update on the [Control Channel](#)
- SSD Update on the [Voice Channel](#)

Performing an SSD Update on the Control Channel

1. Ensure that the Test Set is in the active state. See "[Turn On The Test Set's Control Channel](#)" on page 287 for information on how to activate the Test Set.
2. Connect the mobile station to the Test Set as shown in [Figure 2, "Connecting a Mobile Station to the Test Set,"](#) on page 269.
3. Turn on the mobile station.
4. If the CALL CONTROL screen is not displayed, select **CALL CNTL** from the **To Screen** menu. The CALL CONTROL screen will be displayed.
5. Position the cursor on the **Display** field and select **Date**.
6. Ensure that the Test Set has Initialized Call Processing with Authentication. See "[Initialize Call Processing with Authentication](#)" on page 294 for information on how to register the mobile station and activate Authentication.
7. Select **AUTHEN** on the To Screen menu. The AUTHENTICATION screen will be displayed.
8. Select **RANDSSD_1** field. Enter a new, valid RANDSSD_1 value (6-digit hexadecimal).

9. Select **RANDSSD_2** field. Enter a new, valid RANDSSD_2 value (6-digit hexadecimal).
10. Select **RANDSSD_3** field. Enter a new, valid RANDSSD_3 value (2-digit hexadecimal).
11. Select **CALL CNTL** under the **To Screen** menu. The CALL CONTROL screen will be displayed.
12. Select **SSD Upd** on the **CC Order** field. The **Access** annunciator light will light while the SSD Update order is in progress. If the mobile station responds properly on the reverse control channel, "**SSD Update Order Successful**" will be displayed in the upper right-hand portion of the CALL CONTROL screen. The Test Set and the mobile station are now linked and further call processing functions with authentication can be tested. If the order failed, then "**SSD Update Order Failed**" will appear on the upper right-hand portion of the CALL CONTROL screen.

Performing an SSD Update on the Voice Channel

1. Ensure that the Test Set is in the active state. See "[Turn On The Test Set's Control Channel](#)" on page 287 for information on how to active the Test Set.
2. Connect the mobile station to the Test Set as shown in [Figure 2, "Connecting a Mobile Station to the Test Set,"](#) on page 269.
3. Turn on the mobile station.
4. If the CALL CONTROL screen is not displayed, select **CALL CNTL** from the **To Screen** menu. The CALL CONTROL screen will be displayed.
5. Position the cursor on the **Display** field and select **Data**.
6. Ensure that the Test Set has Initialized Call Processing with Authentication. See "[Initialize Call Processing with Authentication](#)" on page 294 for information on how to register the mobile station and activate Authentication.
7. Ensure that the mobile station is on a voice channel. See "[Page a Mobile Station with Authentication](#)" on page 296.
8. Select **AUTHEN** from the To Screen menu. The AUTHENTICATION screen will be displayed.
9. Select the **RANDSSD_1** field. Enter a new, valid RANDSSD_1 value (6-digit hexadecimal).
10. Select the **RANDSSD_2** field. Enter a new, valid RANDSSD_2 value (6-digit hexadecimal).
11. Select the **RANDSSD_3** field. Enter a new, valid RANDSSD_3 value (2-digit hexadecimal).
12. Select **CALL CNTL** under the **To Screen** menu. The CALL CONTROL screen will be displayed.
13. Select **SSD Upd** on the **VC Order** field. The **Access** annunciator light will light while the SSD Update order is in progress. If the mobile station responds properly on the reverse control channel, "**SSD Update Order Successful**" will be displayed in the upper right-hand portion of the CALL CONTROL screen. If the order failed then "**SSD Update Order Failed**" will appear on the upper right-hand portion of the CALL CONTROL screen.

Perform a Unique Challenge

There are two methods that can be used to perform a Unique Challenge-Response procedure:

- Unique Challenge on the [Control Channel](#)
- Unique Challenge on the [Voice Channel](#)

Performing a Unique Challenge on the Control Channel

1. Ensure that the Test Set is in the active state. See "[Turn On The Test Set's Control Channel](#)" on page 287 for information on how to activate the Test Set.
2. Connect the mobile station to the Test Set as shown in [Figure 2, "Connecting a Mobile Station to the Test Set,"](#) on page 269.
3. Turn on the mobile station.
4. If the CALL CONTROL screen is not displayed, select **CALL CNTL** under the **To Screen** menu. The CALL CONTROL screen will be displayed.
5. Position the cursor on the **Display** field and select **Data**.
6. Ensure that the Test Set has Initialized Call Processing with Authentication. See "[Initialize Call Processing with Authentication](#)" on page 294 for information on how to register the mobile station and activate Authentication.
7. Select **AUTHEN** on the To Screen menu. The AUTHENTICATION will be displayed.
8. Select **RAND_U** field. Enter a new, valid RAND_U value (6-digit hexadecimal).
9. Select **CALL CNTL** under the **To Screen** menu. The CALL CONTROL screen will be displayed.
10. Select **Uniq Chal** from the **CC Order** field. The **Access** annunciator light will light while the Unique Challenge order is in progress. If the mobile station responds properly on the reverse control channel, "**Unique Challenge Successful**" will be displayed in the upper right-hand portion of the CALL CONTROL screen. If the order failed, then "**Unique Challenge Failed**" will appear on the upper right-hand portion of the CALL CONTROL screen.

Performing a Unique Challenge on the Voice Channel

1. Ensure that the Test Set is in the active state. See "[Turn On The Test Set's Control Channel](#)" on page 287 for information on how to activate the Test Set.
2. Connect the mobile station to the Test Set as shown in [Figure 2, "Connecting a Mobile Station to the Test Set,"](#) on page 269.
3. Turn on the mobile station.
4. If the CALL CONTROL screen is not displayed, select **CALL CNTL** from the **To Screen** menu. The CALL CONTROL screen will be displayed.
5. Position the cursor on the **Display** field and select **Data**.
6. Ensure that the Test Set has Initialized Call Processing with Authentication. See "[Initialize Call Processing with Authentication](#)" on page 294 for information on how to register the mobile station and activate Authentication.
7. Ensure that the mobile station is assigned an active voice channel. See "[Page a Mobile Station with Authentication](#)" on page 296.
8. Select **AUTHEN** from the To Screen menu. The AUTHENTICATION screen will be displayed.
9. Select the **RAND_U** field. Enter a new, valid RAND_U value (6-digit hexadecimal).

10. Select **CALL CNTL** from the **To Screen** menu. The CALL CONTROL screen will be displayed.
11. Select **Uniq Ch** from the **VC Order** field. The **Access** annunciator light will light while the Unique Challenge order is in progress. If the mobile station responds properly on the reverse control channel, “**Unique Challenge Successful**” will be displayed in the upper right-hand portion of the CALL CONTROL screen. If the order failed, then “**Unique Challenge Failed**” will appear on the upper right-hand portion of the CALL CONTROL screen.

Using the CALL DATA Screen

1. To View the Decoded Reverse Channel Words from a Mobile Station Registration

1. If not already done, condition the Test Set. See "[Conditioning the Test Set for Call Processing](#)" on page 279 for further information.
2. If not already done, ensure that the Test Set is properly configured. See "[Configure the Test Set](#)" on page 286 for further information.
3. Connect the mobile station to the Test Set as shown in [Figure 2, "Connecting a Mobile Station to the Test Set,"](#) on page 269.
4. Turn on the mobile station.
5. If the CALL DATA screen is not displayed, select **CALL DATA** from the **To Screen** menu. The CALL DATA screen will be displayed.
6. Select the **Active** field. The **Active** annunciator will light when the control channel is turned on.
7. Select the **Register** field. The **Register** annunciator will light while the registration is in process. If the mobile station responds properly on the reverse control channel, the message **RECC Return** will flash momentarily in the upper right-hand corner of the CALL CONTROL screen. The **Active** annunciator will light when the registration has successfully completed.
8. Select the **Display Word** field. A list of reverse channel words which can be displayed will appear in a **Choices:** menu. Select the desired word from the list of choices. The decoded contents for each of the fields in the selected word will be displayed in the lower portion of the display.

NOTE:

If a word is chosen which was not part of the decoded reverse channel message stream, all the fields will be blank when it is displayed.

Steps 7 and Step 8 in the above procedure can be reversed, that is, the desired word can be selected first, then the mobile station can be registered. If the registration is successful, the contents of each display word contained in the reverse control channel's message stream will be updated when the decoding is complete.

The registration does not have to happen while you are viewing the CALL DATA screen. When the CALL DATA screen is viewed, the contents of the display words will be the decoded data from the last successful call processing function (registration, origination, page, release, order).

To View the Decoded Reverse Channel Words from a Mobile Station Page

There are two methods that can be used to view the decoded RVCC words from a mobile station page:

- View the decoded RVCC words from a page for a mobile station that [has registered](#) with the Test Set
- View the decoded RVCC words from a page for a mobile station that [has not registered](#) with the Test Set

Viewing the Decoded Reverse Channel Words from a Page to a Mobile Station that has Registered with the Test Set

1. If not already done, condition the Test Set. [See "Conditioning the Test Set for Call Processing" on page 279](#) for further information.
2. If not already done, ensure that the Test Set is properly configured. [See "Configure the Test Set" on page 293](#) for further information.
3. Connect the mobile station to the Test Set as shown in [Figure 2, "Connecting a Mobile Station to the Test Set," on page 269](#).
4. Turn on the mobile station.
5. If the CALL DATA screen is not displayed, select **CALL DATA** under the **To Screen** menu. The CALL DATA screen will be displayed.
6. Select the **Active** field. The **Active** annunciator will light when the control channel is turned on.
7. Ensure that the mobile station has registered with the Test Set. [See "Register a Mobile Station" on page 287](#) for information on how to register the mobile station.
8. Select the **Page** field. The **Page** annunciator will light while the Test Set pages the mobile on the forward control channel. If the mobile station responds properly on the reverse control channel, the message **RECC Return** will flash momentarily in the upper right-hand corner of the CALL CONTROL screen. The **Access** annunciator will then light while the Test Set sends the mobile station an alert order on the assigned voice channel. The mobile station should ring.
9. Press the SEND key on the mobile station. The **Connect** annunciator will light if the mobile station properly signals the Test Set when the SEND key is pressed. The mobile station is now connected to the Test Set on the assigned voice channel.
10. Select the **Display Word** field. A list of reverse channel words appears in a **Choices:** menu. Select the desired word from the list of choices. The decoded contents for each of the fields in the selected word will be displayed in the lower portion of the display.

NOTE:

If a word is chosen which was not part of the decoded reverse channel's message stream, all the fields will be blank when it is displayed.

Steps 8 and 10 in the above procedure can be reversed, that is, the desired word can be selected first, then the mobile station can be paged. If the page is successful, the contents of each display word contained in the reverse control channel's message stream will be updated when the decoding is complete.

The page does not have to happen while you are viewing the CALL DATA screen. When the CALL DATA screen is viewed, the contents of the display words will be the decoded data from the last successful call processing function (registration, origination, page, release, order).

Viewing the Decoded Reverse Channel Words from a Page to a Mobile Station That Has Not Registered with the Test Set

1. If not already done, condition the Test Set. See "[Conditioning the Test Set for Call Processing](#)" on page 279 for further information.
2. If not already done, configure the Test Set. See "[Configure the Test Set](#)" on page 286
3. Connect the mobile station to the Test Set as shown in [Figure 2, "Connecting a Mobile Station to the Test Set,"](#) on page 269.
4. Turn on the mobile station.
5. If the CALL CONTROL screen is not displayed, select **CALL CNTL** under the **To Screen** menu. The CALL CONTROL screen will be displayed.
6. Select the lower **MS Id** field. Enter the mobile station identification number, either the phone number or the MIN number depending upon what the upper **MS Id** field is set to.
7. Select **CALL DATA** from the **To Screen** menu. The CALL DATA screen will be displayed.
8. Select the **Active** field. The **Active** annunciator will light when the control channel is turned on.
9. Select the **Page** field. The **Page** annunciator will light while the Test Set pages the mobile on the forward control channel. If the mobile station responds properly on the reverse control channel, the message **RECC Return** will flash momentarily in the upper right-hand corner of the CALL CONTROL screen. The **Access** annunciator will then light while the Test Set sends the mobile station an alert order on the assigned voice channel. The mobile station should ring.
10. Press the SEND key on the mobile station. The **Connect** annunciator will light if the mobile station properly signals the Test Set when the SEND key is pressed. The mobile station is now connected to the Test Set on the assigned voice channel.
11. Select the **Display Word** field. A list of reverse channel words which can be displayed will appear in a **Choices:** menu. Select the desired word from the list of choices. The decoded contents for each of the fields in the selected word will be displayed in the lower portion of the display.

NOTE:

If a word is chosen which was not part of the decoded reverse channel's message stream, all the fields will be blank when it is displayed.

Step 9 and step 11 in the above procedure can be reversed, that is - the desired word can be selected first, then the mobile station can be paged. If the page is successful, the contents of each display word contained in the reverse control channel's message stream will be updated when the decoding is complete.

The page does not have to happen while you are viewing the CALL DATA screen. When the CALL DATA screen is viewed, the contents of the display words will be the decoded data from the last successful call processing function (registration, origination, page, release, order).

To View the Decoded Reverse Channel Words From a Mobile Station Handoff

1. If not already done, condition the Test Set. See "**Conditioning the Test Set for Call Processing**" on page 279 for further information.
2. If not already done, configure the Test Set. See "**Configure the Test Set**" on page 293 for further information.
3. Connect the mobile station to the Test Set as shown in **Figure 2, "Connecting a Mobile Station to the Test Set,"** on page 269.
4. Turn on the mobile station.
5. Ensure that the Test Set is in the **Connect** state. See "**Page a Mobile Station**" on page 288 for information on how to bring a mobile station up on a voice channel.
6. If the CALL CONTROL screen is not displayed, Select **CALL CNTL** from the **To Screen** menu. The CALL CONTROL screen will be displayed.
7. Select the **Chan:** field and enter a new, valid voice channel number from the choices provided.
8. Select the **Ch Loc:** field (**NAMPS System Type** only) and enter a new, valid channel location from the choices provided.
9. Select the **Pwr Lvl:** field and enter a new, valid mobile station power level.
10. Select the **DSAT:** field (**NAMPS System Type** only) and enter a new, valid DSAT from the choices menu.
11. Select the **SAT:** field and enter a new, valid SAT frequency.
12. Select **CALL DATA** from the **To Screen** menu. The CALL DATA screen will be displayed.
13. Select the **Handoff** field. The **Access** annunciator will light while the Test Set signals the mobile station with the handoff information. If the mobile responds properly, it will stop transmitting on the current voice channel, switch to the new voice channel assignment, and transpond the new SAT frequency assignment. When the Test Set detects this has happened, the **Connect** annunciator lights indicating the handoff was successful.
14. Select the **Display Word** field. A list of reverse channel words which can be displayed will appear in a **Choices:** menu. Select the desired word from the list of choices. The decoded contents for each of the fields in the selected word will be displayed in the lower portion of the display.

NOTE:

If a word is chosen which was not part of the decoded reverse channel's message stream, all the fields will be blank when it is displayed.

Step 14 and step 15 in the above procedure can be reversed, that is - the desired word can be selected first, then the mobile station can be handed off. If the handoff is successful, the contents of each display word contained in the reverse control channel's message stream will be updated when the decoding is complete.

The handoff does not have to happen while you are viewing the CALL DATA screen. When the CALL DATA screen is viewed, the contents of the display words will contain the decoded data from the last successful call processing function (registration, origination, page, release, order).

To View the Decoded Reverse Channel Words from a Mobile Station Release

1. If not already done, condition the Test Set. See "[Conditioning the Test Set for Call Processing](#)" on page 279 for further information.
2. If not already done, configure the Test Set. See "[Configure the Test Set](#)" on page 286 for further information.
3. Connect the mobile station to the Test Set as shown in [Figure 2, "Connecting a Mobile Station to the Test Set,"](#) on page 269.
4. Turn on the mobile station.
5. Ensure that the Test Set is in the **Connect** state. See "[Page a Mobile Station](#)" on page 288 for information on how to bring a mobile station up on a voice channel.
6. Select **CALL DATA** under the **To Screen** menu. The CALL DATA screen will be displayed.
7. Select the **Release** field. The Test Set will signal the mobile station with a release order. The mobile station will respond to the release order and cease transmission. The Test Set will terminate transmission on the forward voice channel and the **Connect** annunciator will turn off. The Test Set will then reconfigure itself for transmission on the forward control channel, begin to transmit system parameter overhead messages and the **Active** annunciator will light.
8. Select the **Display Word** field. A list of reverse channel words which can be displayed will appear in a Choices: menu. Select the desired word from the list of choices. The decoded contents for each of the fields in the selected word will be displayed in the lower portion of the display.

NOTE:

If a word is chosen which was not part of the decoded reverse channel's message stream, all the fields will be blank when it is displayed.

Step 7 and step 8 in the above procedure can be reversed, that is, the desired word can be selected first, then the mobile station can be released. If the release is successful, the contents of each display word contained in the reverse control channel's message stream will be updated when the decoding is complete.

The release does not have to happen while you are viewing the CALL DATA screen. When the CALL DATA screen is viewed, the contents of the display words will contain the decoded data from the last successful call processing function (registration, origination, page, release, order).

To View the Decoded Reverse Channel Words from an Order to Change the Transmit Power Level of a Mobile Station

1. If not already done, condition the Test Set. See "[Conditioning the Test Set for Call Processing](#)" on page 279 for further information.
2. If not already done, configure the Test Set. See "[Configure the Test Set](#)" on page 286 for further information.
3. Connect the mobile station to the Test Set as shown in [Figure 2, "Connecting a Mobile Station to the Test Set,"](#) on page 269.
4. Turn on the mobile station.
5. Ensure that the Test Set is in the **Connect** state. See "[Page a Mobile Station](#)" on page 288 for information on how to bring a mobile station up on a voice channel.
6. If the CALL DATA screen is not displayed, select **CALL DATA** under the **To Screen** menu. The CALL DATA screen will be displayed.
7. Select the **Order** field and select it. A **Choices:** menu is displayed showing the various power levels which the mobile station can be set to. Select the desired power level. The **Access** annunciator will light while the Test Set signals the mobile station with an order to set its power level. If the mobile responds properly, the message **REVC Return** will flash momentarily in the upper right-hand corner of the CALL CONTROL screen. The **Connect** annunciator will light when signaling is complete.
8. Select the **Display Word** field. A list of reverse channel words which can be displayed will be presented. Position the cursor on the desired word and select it. The decoded contents for each of the fields in the selected word will be displayed in the lower portion of the display.

NOTE:

If a word is chosen which was not part of the decoded reverse channel's message stream, all the fields will be blank when it is displayed.

Step 7 and step 8 in the above procedure can be reversed, that is, the desired word can be selected first, then the mobile station can be sent an order to change transmit power level. If the order is successful, the contents of each display word contained in the reverse control channel's message stream will be updated when the decoding is complete.

The ordered to change transmit power does not have to happen while you are viewing the CALL CONTROL screen. When the CALL DATA screen is viewed, the contents of the display words will be the decoded data from the last successful call processing function (registration, origination, page, release, order).

To View The Reverse Channel Words From a Mobile Station Origination

1. If not already done, condition the Test Set. See "[Conditioning the Test Set for Call Processing](#)" on page 279 for further information.
2. If not already done, configure the Test Set. See "[Configure the Test Set](#)" on page 293 for further information.
3. [Figure 2, "Connecting a Mobile Station to the Test Set,"](#) on page 269 Connect the mobile station to the Test Set as shown in
4. Turn on the mobile station.
5. Ensure that the Test Set is in the **Connect** state. See "[Page a Mobile Station](#)" on page 288 for information on how to bring a mobile station up on a voice channel.
6. Select the **Active** field. The **Active** annunciator will light when the control channel is turned on.
7. Dial the desired phone number on the mobile station and press the SEND key on the mobile station's handset. The mobile station signals the Test Set on the reverse control channel with an origination message which includes the dialed phone number, the mobile station's MIN number and the mobile station's ESN. If the mobile station transmitted properly on the reverse control channel, the message **RECC Return** will flash momentarily in the upper right-hand corner of the CALL CONTROL screen. The Test Set will then reconfigure itself to the voice channel assignments set up in the **Voice Channel Assignment** section of the CALL CONTROL screen. The **Access** annunciator will then light while the Test Set signals the mobile station on the assigned voice channel. The **Connect** annunciator will light if the mobile station properly signals the Test Set on the reverse voice channel. The mobile station is now connected to the Test Set on the assigned voice channel.
8. Select the **Display Word** field. A list of reverse channel words which can be displayed will be presented. Position the cursor on the desired word and select it. The decoded contents for each of the fields in the selected word will be displayed in the lower portion of the display.

NOTE:

If a word is chosen which was not part of the decoded reverse channel's message stream, all the fields will be blank when it is displayed.

Step 7 and step 8 in the above procedure can be reversed, that is, the desired word can be selected first, then a mobile station origination can be performed. If the origination is successful, the contents of each display word contained in the reverse control channel's message stream will be updated when the decoding is complete.

The origination does not have to happen while you are viewing the CALL DATA screen. When the CALL DATA screen is viewed, the contents of the display words will contain the decoded data from the last successful call processing function (registration, origination, page, release, order).

Using the CALL BIT Screen

Selecting The Message Content Generation Method

The contents (i.e. bit patterns) of the signaling messages sent to the mobile station on the forward control channel and the forward voice channel are generated using one of two methods. Method 1 uses the formats defined in the applicable industry standard to build the contents of the signaling messages. Method 2 uses the bit patterns which the user defines on the CALL BIT screen to build the contents of the signaling messages.

The **Data Spec** field on the CALL BIT screen determines which method will be used to build the contents of the signaling messages.

- **std** -The Test Set will use the signaling formats defined in the applicable industry standard to build the forward control channel and forward voice channel signaling messages. The Test Set will use the contents of the applicable fields on the CALL CONTROL screen and the CALL CONFIGURE screen to obtain information necessary to build the messages. Whenever a signaling message is used, the Test Set will update the contents of all fields in that message on the CALL BIT screen.
- **bits** -Use the bit patterns as set on the CALL BIT screen to build *all* forward control channel and forward voice channel signaling messages. For any call processing function (that is, setting the message stream on the active control channel, registering the mobile station, paging the mobile station, handing off the mobile station or releasing the mobile station) the user is responsible for setting the contents of all signaling messages used in that function. The Call Processing Subsystem uses the messaging protocol as defined in the applicable industry standard.

NOTE:

The contents of the applicable fields on the CALL CONTROL screen and the CALL CONFIGURE screen are *not* updated to reflect any changes made while in the Bits mode. There is no coupling between the Bits mode and the Test Set. For example: if a mobile station was actively connected to the Test Set on a voice channel and the user changed the **CHAN** field on the forward voice channel mobile station control message (FVC V Mes) and sent that message to the mobile station, the mobile station would change its voice channel assignment. However, the Test Set will stay on the voice channel assignment specified in the **Chan:** field on the CALL CONTROL screen. This situation will result in a dropped call. The Bits mode should not be used to change any parameter that can be set on any other Call Processing Subsystem screen.

System Operation When Data Spec Field Set to Std

When the **Data Spec** field is set to **std** the Test Set builds the signaling messages by first examining the fields which contain the information needed to build the messages (i.e. SID, BIS, SAT Tone, VMAC, etc.). After obtaining the necessary information the Test Set builds the bit patterns according to the signaling formats specified in the applicable industry standard.

For example: if the type of cellular system being emulated is AMPS and the **SID** field on the CALL PROC screen was set to 231, the **SID1** field in the System Parameter Overhead Message (SPC WORD1) would be set to 00000001110011 (the 14 most significant bits of the system identification number) as defined by the *EIA/TIA-553 Mobile Station - Land Station Compatibility Specification*.

When the **Data Spec** field is set to **std**, the contents of the applicable message(s) on the CALL BIT screen are updated with the bit patterns generated using the signaling formats defined in the applicable industry standard whenever that signaling message is sent to the mobile station. This feature allows a user to set the **Data Spec** field to **std**, select a message of interest, perform a call processing function, and view the bit patterns generated using the signaling formats defined in the applicable industry standard.

It is important to note individual messages can be used more than once during a messaging protocol. The contents of any message viewed on the CALL BIT screen when the **Data Spec** field is set to **std** will reflect the message contents for the last time the message was used in a messaging protocol.

For example: if the Call Processing Subsystem is in the active state and the user selects the **Register** field, a registration message will be sent to the mobile station. When the registration completes the Call Processing Subsystem returns to the active state. The contents of some messages (such as the System Parameter Overhead Message Word 1) will reflect the correct settings for the active state, not the register state, since the messages are currently being used in the active state.

System Operation When Data Spec Field Set to Bits

When the **Data Spec** field is set to **Bits**, the Test Set builds the signaling messages using *only* the bit patterns set on the CALL BIT screen whenever a call processing function is executed which uses any of the available messages. The Test Set calculates the contents of the **Parity** field using the coding algorithms specified in the industry standard for the selected system (that is, the system specified in the **System Type** field on the CALL CONTROL screen).

By definition, the Test Set must meet the timing requirements of the industry standard for the selected system. Therefore, depending upon the state of the Call Processing Subsystem (i.e. Active, Register, Page, Access, or Connect) and the frequency with which a particular call processing protocol uses a particular message, it may not be possible to modify the contents of more than one field in a message before it is sent to the mobile station.

For example: in the AMPS system, the system parameter overhead message must be sent every 0.8 +/- 0.3 seconds on the forward control channel. Given this timing requirement it is highly unlikely that, while in the active state, a user could modify more than one field before the message was sent to the mobile station.

There is no functionality in the Test Set to allow an entire message to be modified and then inserted into a messaging protocol at a specific location at a specific time. This functionality requires a protocol analyzer.

When in the **Bits** mode the Test Set provides the messaging protocol for the user (that is, for a desired call processing function the correct message(s) will be sent at the correct time(s) according to the standard). It is the responsibility of the user to generate the contents of all the messages which will be used in a particular call processing function.

For example: if the Call Processing Subsystem was in the active state and the operator wished to register the mobile station from the **Bits** mode, the user would have to set the contents of all the messages used in the registration before selecting the **Register** field to start the registration process.

NOTE:

No error checking is done on the bit patterns. The bit patterns are used but are not checked against any industry standard. It is the responsibility of the user to ensure that the bit patterns set in the CALL BIT screen are correct when the **Data Spec** field is set to **Bits**. Unexpected operation of the mobile station can occur if the contents of the signaling messages are incorrect.

Changing the Content of a Message Field

Perform the following steps to change the contents of a message field:

1. Position the cursor on the **Data Spec** field and select **Bits**.
2. Select the **Set Message** field. A **Choices:** menu is displayed listing the available messages. Select the desired message. The message fields will be displayed on the screen.
3. Select the desired bit field. A **Choices:** menu will be displayed. Using the **Choices:** menu enter the desired bit pattern. Select **Done** from the **Choices:** menu when the desired bit pattern has been entered.

When a message field is being modified the original contents of the field (that is - the contents of the field before modification was started) is sent whenever the message is used in a messaging protocol. The new contents are not used until **Done** is selected from the **Choices:** menu. Use the CANCEL key to abort a modification. If the CANCEL key is selected the original field contents are restored.

NOTE:

If a message field is modified while the **Data Spec** field is set to **Std** the modified contents will be overwritten with the bit patterns generated using the signaling formats defined in the applicable industry standard immediately after **Done** is selected from the **Choices:** menu.

Typical Example

The following example illustrates the use of the CALL BIT screen. In this example an AMPS mobile station is brought up on a voice channel and then handed off to a new voice channel assignment. The contents of the **FVC V Msg** message, which was set when the first handoff occurred, is then modified from the CALL BIT screen. The mobile station is then handed off again by sending the modified message to the mobile station from the CALL BIT screen.

1. Ensure that the Test Set is in the connected state. See "[Page a Mobile Station](#)" on [page 288](#) for information on how to bring a mobile station up on a voice channel.
2. If the CALL CONTROL screen is not displayed, select **CALL CNTL** under the **To Screen** menu. The CALL CONTROL screen will be displayed.
3. Position the cursor on the **Display** field and select **Data**.
4. Select the **Chan:** field and enter a new, valid voice channel number.
5. Select the **Pwr Lvl:** field enter a new, valid mobile station power level.
6. Select the **SAT:** field and enter a new, valid SAT frequency.

7. Select the **Handoff** field. The **Access** annunciator will light while the Test Set signals the mobile station with the handoff information. If the mobile responds properly, it will stop transmitting on the current voice channel, switch to the new voice channel assignment, and transpond the new SAT frequency assignment. When the Test Set detects that this has happened the **Connect** annunciator is lit indicating that the handoff was successful. The left-hand fields in the **Voice Channel Assignment** section will be updated with the new voice channel assignment information.
8. Select **CALL BIT** from the **To Screen** menu. The CALL BIT screen will be displayed.
9. Position the cursor on the **Data Spec** field and select **Bits**.
10. Select the **Set Message** field and select **FVC V Msg**.
11. Select the **VMAC** field in the **FVC V Msg** and set it to 101 (this corresponds to a mobile station power level of 5 - reference *EIA/TIA-553 Mobile Station - Land Station Compatibility Specification*, September 1989, page 2-2, Table 2.1.2-1).
12. Select the **Handoff** field. The **Access** annunciator will light while the Test Set signals the mobile station with the handoff information. If the mobile responds properly, it will stop transmitting on the current voice channel, and start transmitting on the same channel with a power level of 5 (note that the channel assignment and SAT assignment were not modified in this example, the mobile station simply switched to the same channel with the same SAT assignment). When the Test Set detects that this has happened, the **Connect** annunciator is lit indicating that the handoff was successful. The mobile station power level after the handoff should be power level 5.
13. Position the cursor on the **Data Spec** field and select **Std**.

Using the ANALOG MEAS Screen

The ANALOG MEAS screen combines some of the Test Set's **Audio Analyzer** fields and some of the Test Set's RF Generator fields onto one screen for the purpose of testing the audio characteristics of the mobile station. Only those fields which are pertinent to testing the mobile stations audio characteristics have been combined onto the ANALOG MEAS screen. The Test Set must be in the connected state (that is, the **Connect** annunciator is lit) in order to use the ANALOG MEAS screen.

The mobile station's speaker output must be connected to the Test Set's AUDIO IN connector and the mobile station's microphone input must be connected to the Test Set's AUDIO OUT connector in order to use the ANALOG MEAS screen. Refer to [Figure 2, "Connecting a Mobile Station to the Test Set," on page 269](#) for connection information. If the mobile station does not have audio connections the ANALOG MEAS screen cannot be used.

There are a wide variety of audio measurements which can be made from the ANALOG MEAS screen. The following examples illustrate how to make a typical mobile station receiver measurement (RF Sensitivity) and a typical mobile station transmitter measurement (FM Hum and Noise).

To Make an RF Sensitivity Measurement

1. If not already done, condition the Test Set. See ["Conditioning the Test Set for Call Processing" on page 279](#) for further information.
2. If not already done, configure the Test Set. See ["Configure the Test Set" on page 286](#) for further information.
3. Connect the mobile station to the Test Set as shown in [Figure 2, "Connecting a Mobile Station to the Test Set," on page 269](#).

NOTE:

The mobile station's speaker output must be connected to the Test Set's AUDIO IN and the mobile station's microphone input must be connected to the Test Set's AUDIO OUT in order to use the ANALOG MEAS screen.

4. Turn on the mobile station.
5. Ensure that the Test Set is in the connected state. See ["Page a Mobile Station" on page 288](#) for information on how to bring a mobile station up on a voice channel.
6. If the ANALOG MEAS screen is not displayed, select the **ANLG MEAS** field from the **To screen** menu. The ANALOG MEAS screen will be displayed.
7. The following example illustrates how to make a 12 dB SINAD Receiver Sensitivity measurement:
 - a Select the **AFGen1 Freq** field and set it to 1 kHz.
 - b Select the upper **AFGen1 To** field and set it to **FM**.

- c Select the lower **AFGen1 To** field and set it to 8 kHz.
- d Select the **AF Anl In** field and select **Audio In**.
- e Select the **Filter 1** field and select **C MESSAGE**.
- f Select the **Filter 2** field and select **>99kHz LP**.
- g Position the cursor on the **De-Emphasis** field and select **Off**.
- h Select the **Detector** field and select **RMS**.
- i Select the **AF Freq** measurement field and select **SINAD**.
- j Select the **Amplitude** field and begin to lower the transmitted base station voice channel power until 12 dB SINAD is reached.

NOTE:

The mobile station might mute or drop off the air before a 12 dB SINAD is reached. The performance of the mobile station at low RF levels is dependent upon the characteristics of the mobile station (that is, what type of system it is designed for). Unlike a real base station, the Test Set does not perform any protocol functions on the voice channel.

To Make an FM Hum and Noise Measurement

1. If not already done, condition the Test Set. See "[Conditioning the Test Set for Call Processing](#)" on page 285 for further information.
2. If not already done, configure the Test Set. See "[Configure the Test Set](#)" on page 286 for further information.
3. Connect the mobile station to the Test Set as shown in [Figure 2, "Connecting a Mobile Station to the Test Set,"](#) on page 269.

NOTE:

The mobile station's speaker output must be connected to the Test Set's AUDIO IN and the mobile station's microphone input must be connected to the Test Set's AUDIO OUT in order to use the ANALOG MEAS screen.

4. Turn on the mobile station.
5. Ensure that the Test Set is in the connected state. See "[Page a Mobile Station](#)" on page 288 for information on how to bring a mobile station up on a voice channel.
6. If the ANALOG MEAS screen is not displayed, select the **ANLG MEAS** field from the **To Screen** menu. The ANALOG MEAS screen will be displayed.

NOTE:

It is recommended that the mobile station's microphone be muted, if possible, when making measurements on the mobile stations RF carrier. If the microphone is not muted it is possible for extraneous noise to be picked up by the microphone and adversely affect the measurements.

7. The following example illustrates how to make a FM Hum and Noise measurement:
 - a Select the **Amplitude** field and set it to -47 dBm.
 - b Select the **AFGen1 Freq** field and set it to 1 kHz.
 - c Select the upper **AFGen1 To** field and set it to **Audio Out**.
 - d Select the **AF Anl In** field and select **FM Demod**.
 - e Select the **Filter 1** field and select **C MESSAGE**.
 - f Select the **Filter 2** field and select **>99kHz LP**.
 - g Position the cursor on the **De-Emphasis** field and select **750 us**.

- h** Select the **Detector** field and select **PK+**.
- i** Select the measurement field and select **AF Freq.**
- j** Select the lower **AFGen1 To** field and adjust the signal level until the **FM Deviation** field on the upper portion of the CRT reads 8 kHz.
- k** Select the **Detector** field and select **RMS**.
- l** Select the **FM Deviation** field.
- m** Press the blue SHIFT key, the INCR ÷10 key, then the ENTER key. This sets a zero reference point.
- n** Select the lower **AFGen1 To** field and press the ON/OFF key. This turns off the modulating signal to the mobile station transmitter.
- o** The FM Hum and Noise figure is displayed in the **FM Deviation** field.

10

Controlling Program Flow

Using Service Request (SRQ) Interrupts

The Test Set provides many status bits which can be read directly or used to generate SRQ interrupts. For example, the following status indicators have status bits (in addition to front panel annunciators):

- Transmitting
- Registered
- Page Sent
- Access Probe
- Connected
- Softer Handoff
- Hard Handoff

SRQ interrupts require more program code than requesting status at different time intervals (polling), but interrupts have the advantage of allowing the Call Processing Subsystem to operate at its maximum speed since processes within the subsystem are not constantly interrupted by commands on the HP-IB.

See "[Status Register Programming Considerations](#)" in the Status Reporting chapter of the *HP 8924C User's Guide*.

If your computer system or programming language does not support the SRQ feature of the HP-IB, polling will be required.

Controlling Program Flow Procedure

Examples Used in this Procedure

Computer System

An HP 9000 Series 300 running the HP BASIC programming language was used to develop the following procedure and program example.

Description of Program Example

The following procedure provides example commands that will generate an SRQ Interrupt when the **Connected** bit, (bit 3 in the CDMA Status Register Group) indicates that a call has been dropped.

See "[Status Register Programming Considerations](#)" in the Status Reporting chapter of the *HP 8924C User's Guide* for detailed reference information about status reporting structure and status register group bit definitions.

1. Decide which conditions will be used to generate an SRQ interrupt.

For the following procedure and programming example, the **Connected** bit, (bit 3 in the CDMA Status Register Group) will generate an SRQ interrupt when a high-to-low transition occurs, indicating that a call ended or was dropped.

Use the tables in "[Status Register Programming Considerations](#)" in the Status Reporting chapter of the *HP 8924C User's Guide* to determine the Status Register Group and bit assignment for each condition or event that will be used to generate an SRQ interrupt.

For example, the **Connected** status bit is found in the "[Operation Status Register Group Bit Assignments](#)" in the Status Reporting chapter of the *HP 8924C User's Guide*.

Refer to [Figure 4 on page 320](#) for a display of all of the Status Register Groups.

Note that the CDMA Status Register Group summary message bit (SMB) does not report directly into the Status Byte Register Group. Instead, it is routed to the Operation Status Register Group, and must be enabled in both register groups to allow an SRQ interrupt from the CDMA Status Register Group to be generated. This is a key point to remember as you follow this procedure.

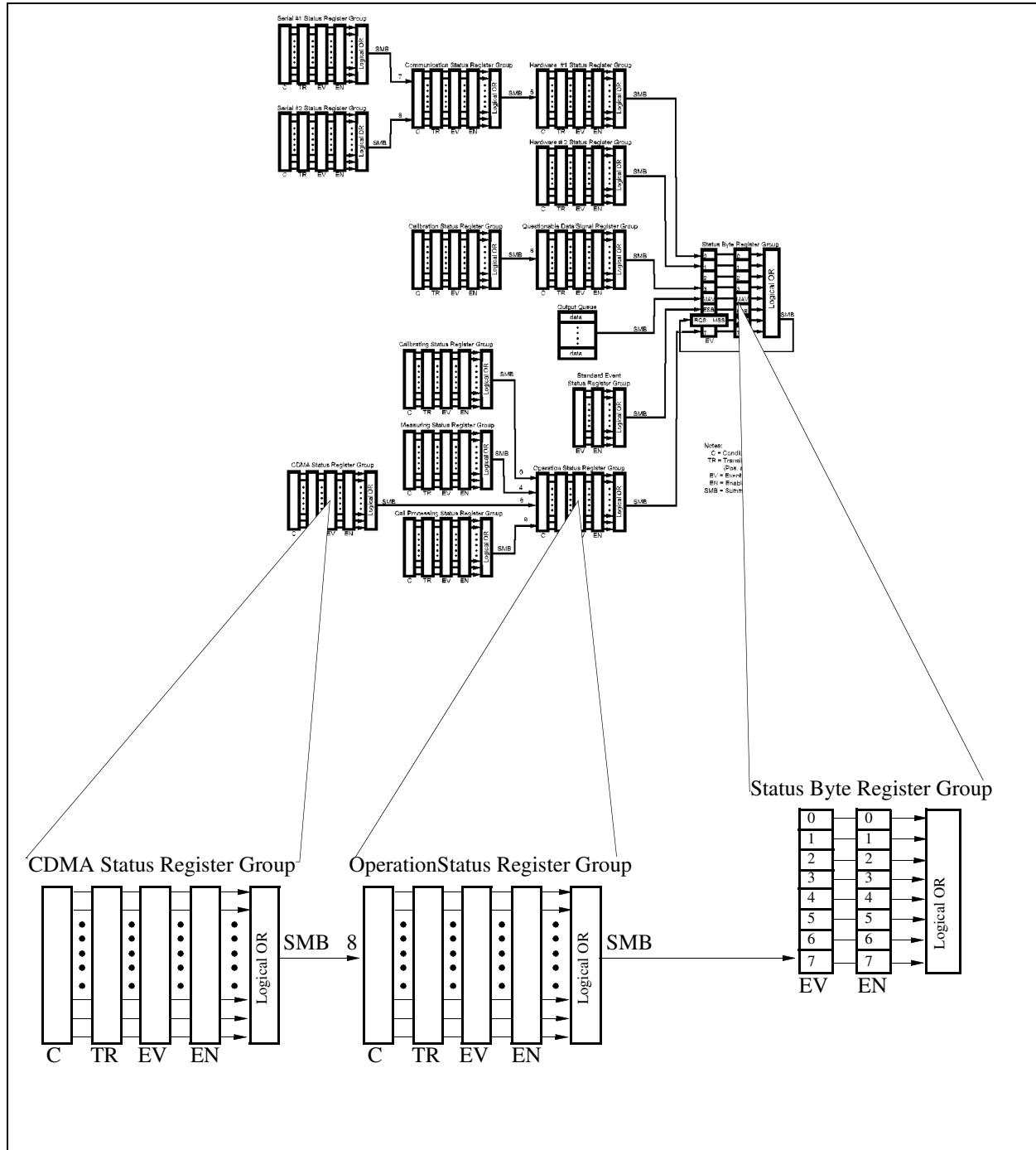

Figure 4 Test Set Data Structures

2. Set up the CDMA Status Register Group Transition Filters.

Sending the following command will allow the CDMA Event register to capture one condition only; a negative transition of the **Connected** bit.

"STAT:CDMA:PTR 0;NTR 8"

The PTR and NTR commands select which transitions of Condition bits will set corresponding event bits.

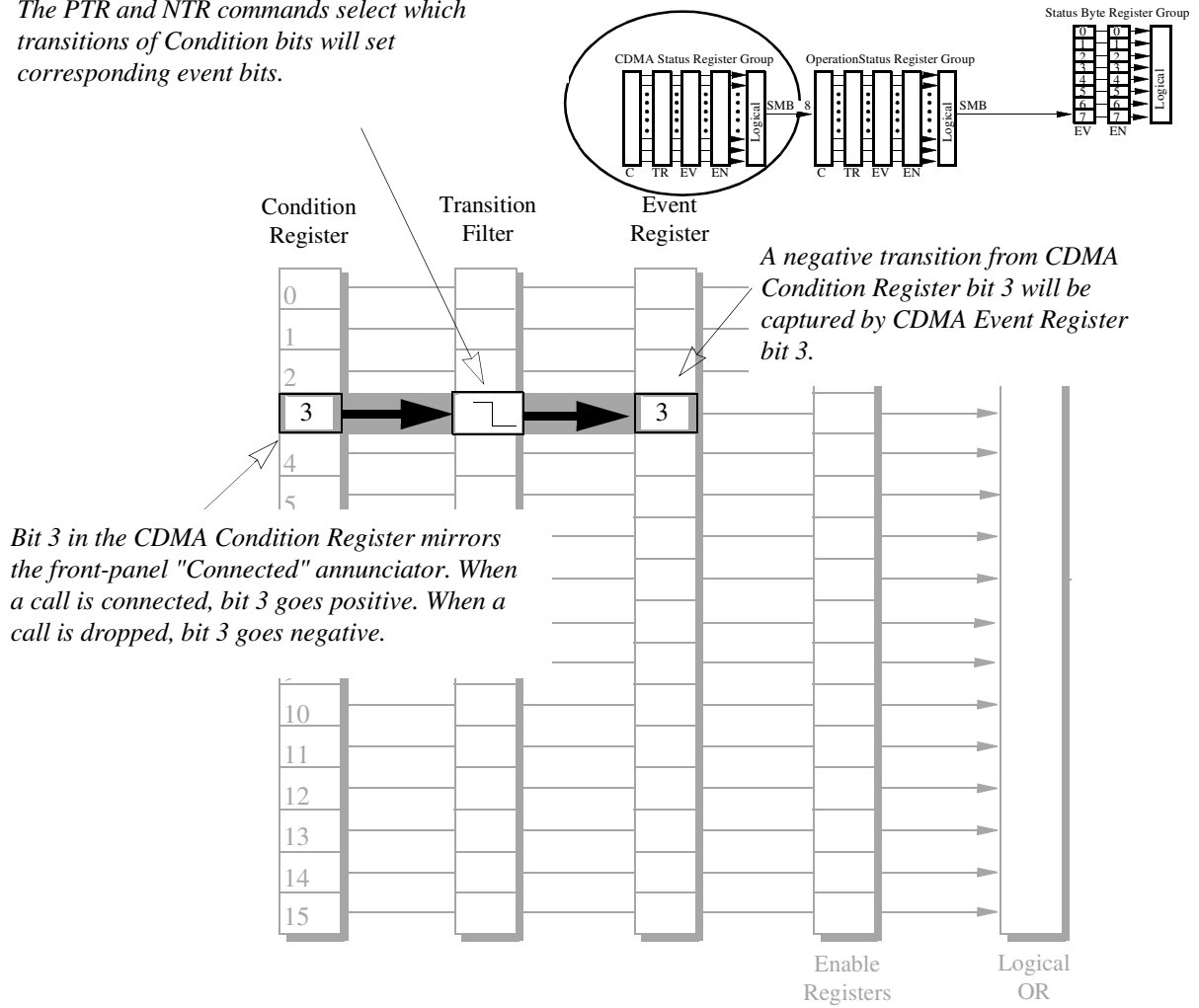

3. Enable the CDMA Status Register Group SMB.

Sending the following command will set the SMB from the CDMA Status Register Group on one condition; when bit 3 in the Event Register is set:

"STAT:CDMA:ENAB 8"

The ENAB command selects which Events can set the Summary Message bit.

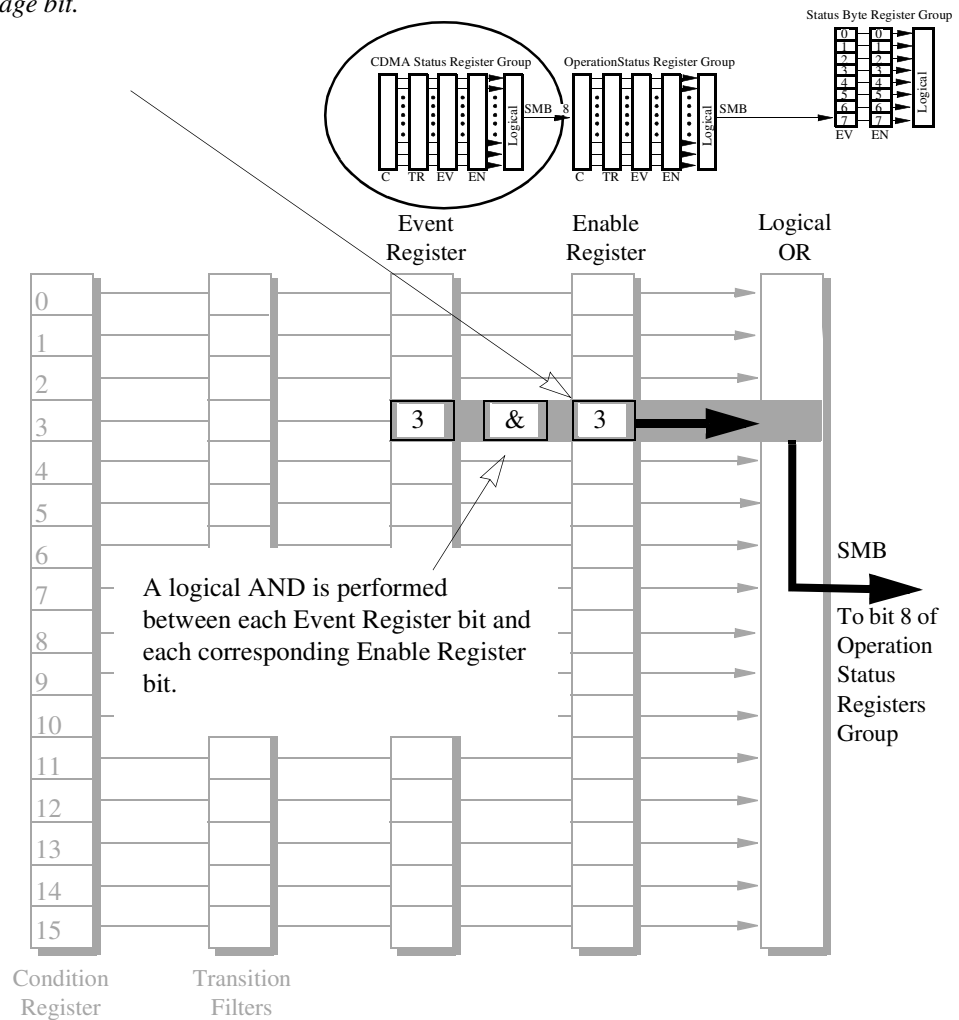

4. Enable the Operation Status Register Group SMB.

Sending the following command will enable the SMB from the Operation Status Register Group to be set by the CDMA SMB:

"STAT:OPER:ENAB 256"

The Operation Status Register Group Transition Filters' default settings are acceptable in this case because the SMB from the CDMA Status Register Group will transition from a negative to a positive state when a call is dropped. The default setting latches all negative to positive state transitions. Message true.

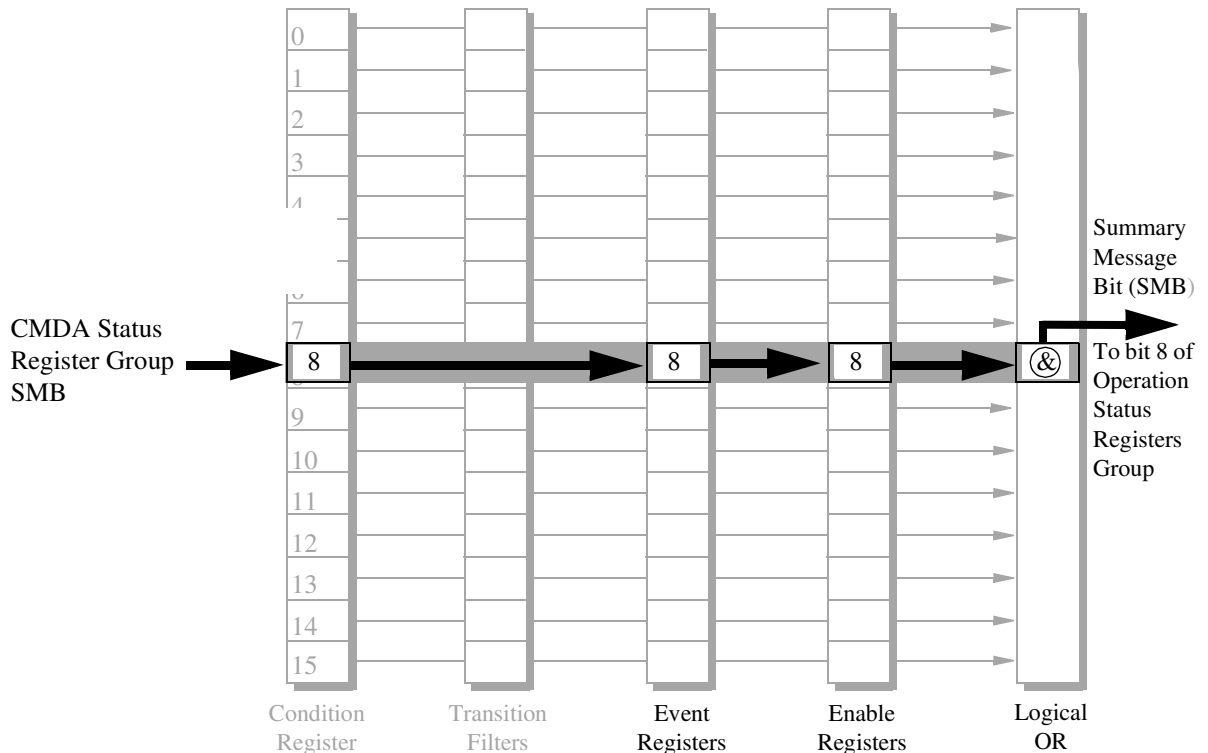
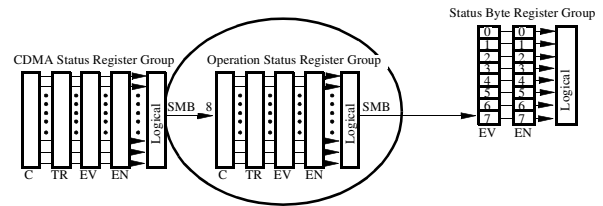

5. Enable SRQ Generation.

Send the following command to enable service request generation when the SMB from the Operation Status Register Group SMB is true:

"*SRE 128"

The Service Request Enable Register selects which SMB(s) will generate a service request.

Refer to "Service Request Enable Register" in the Status Reporting chapter of the *HP 8924C User's Guide*.

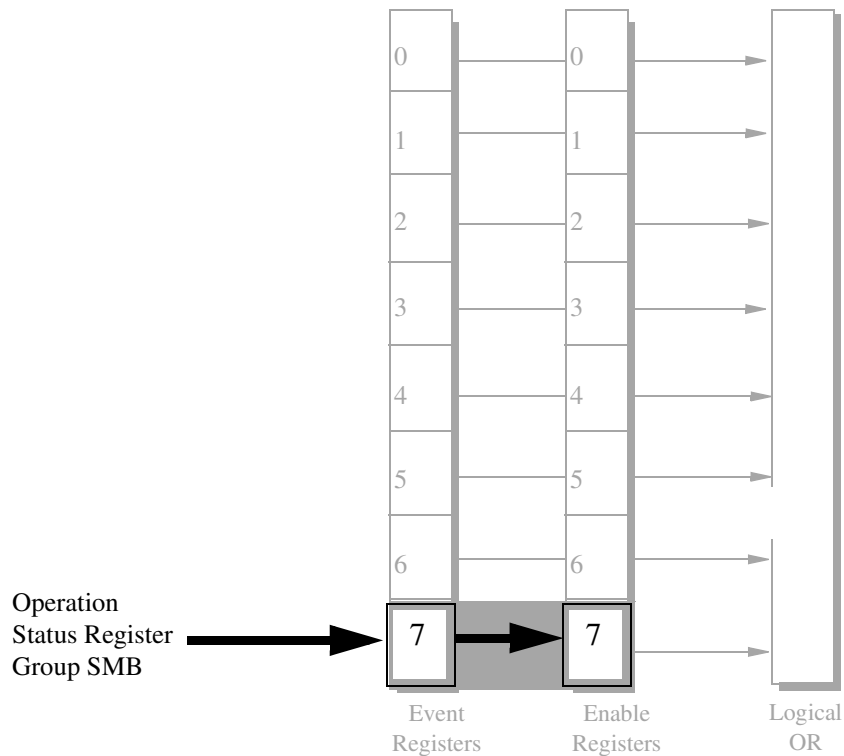
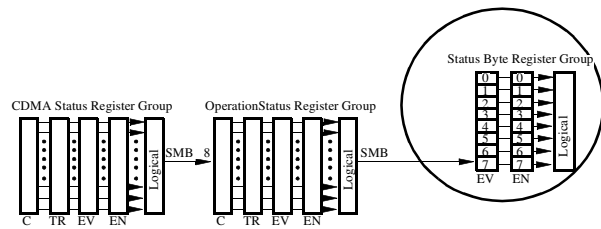

6. Define the program branch desired when an enabled interrupt occurs.

To cause the HPBASIC program to branch to a subprogram called "Service_Int" when an interrupt occurs, the following command must be executed:

```
"ON INTR 7,15 CALL Service_int"
```

The number 7 is the Interface Select Code, and the number 15 designates the priority (1-15, with 15 being the highest).

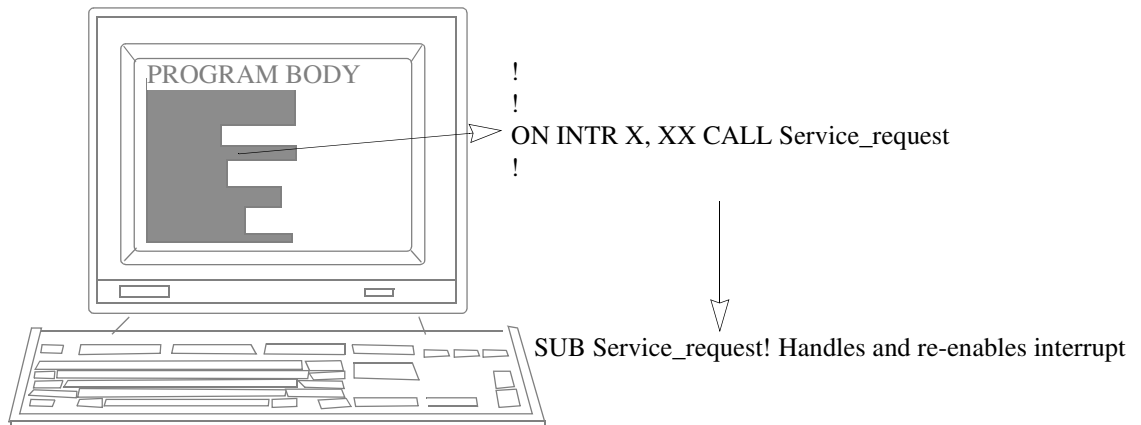

7. Enable the Interrupt.

1. To enable the interrupt in HP BASIC, the following command is executed:

"ENABLE INTR 7;2"

2. After this command is executed, an SRQ from the Test Sets' HP-IB interface will cause the application program to branch to the subprogram specified in the ON INTR command (see previous step).

The number 7 is the Interface Select Code for the Test Set's HP-IB, and the number 2 is the decimal equivalent for bit 1, the SRQ Received bit in the HP-IB Status Register.

Interface Select Code 7 Performs service request function via SRQ Interface Message.

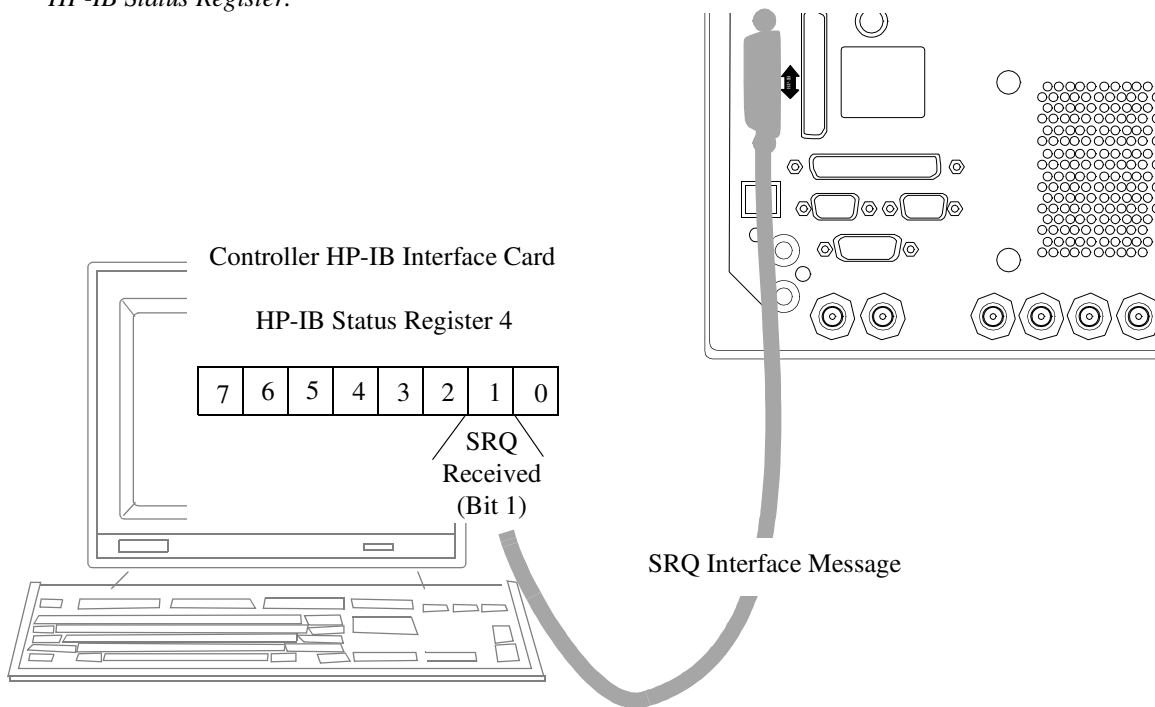

8. Service the interrupt.

To re-enable the SRQ interrupt after branching to the line in your code that services the interrupt:

1. Clear the Status Byte Register. Example:

Status Byte = SPOLL (714).

NOTE:

The SPOLL command queries the Status Byte Register. Bit 6 is the RQS bit, and should be set indicating that the Test Set requested service.

2. Query the Event Register. Example:

"STAT:CDMA:EVEN?"

Since our example set up an interrupt only on the CDMA Status Register Bit 3, Bit 3 should be true when you read the Event Register. This command also clears the contents of the CDMA Event Register.

3. Clear other Event Registers in the path to the Status Byte Register Group. Examples:

"STAT:OPER:EVEN?"

reads the Operation Status Register Group Event Register, clearing its contents so that another interrupt won't be generated until the SMB from the CDMA Status Register Group is true.

"*CLS"

clears *all* the event register contents. (Using this command will work for this example, but would not be a good choice if multiple events were generating SRQ interrupts, because bits that flag other events would be cleared).

4. Re-enable the SRQ Interrupt.

"ENABLE INTR"

5. Branch to return line. Example:

GOTO XXX

Example BASIC Program to Set Up and Service an SRQ Interrupt

The following HP BASIC program was written for an HP 9000 Series 300 Controller and an HP 8924C. The program assumes that the HP 8924C is the only instrument on the bus. The program sets up an interrupt from the Standard Event Status Register Group, the Calibration Status Register Group, and the Hardware Status Register #1 Group. For demonstration purposes the program is written to stay in a dummy loop waiting for an interrupt from the HP 8924C.

```
10 OPTION BASE 1
20 COM/Io_names/INTEGER Inst_address,Std_event_reg,Calibration_reg
30 COM /Io_names/ INTEGER Hardware1_reg,Srq_enab_reg,Status_byte,Event_reg
40 !
50 ! Define HP 8920B instrument address
60 Inst_address=714
70 !
80 PRINTER IS CRT
90 CLEAR SCREEN
100 !
110 ! Reset the HP 8920B to bring it to a known state
120 OUTPUT Inst_address;"*RST"
130 !
140 ! Clear the HP 8920B status reporting system
150 OUTPUT Inst_address;"*CLS"
160 !
170 ! Set up the desired interrupt conditions in the HP 8920B:
180 !
190 ! 1) Standard Event Status Register Group
200 ! Event register conditions which will set the Summary Message
210 ! TRUE if they occur:
220 ! Bit 5: Command Error decimal value = 2^5 = 32
230 ! Bit 4: Execution Error decimal value = 2^4 = 16
240 ! Bit 3: Device Dependent Error decimal value = 2^3 = 8
250 ! Bit 2: Query Error decimal value = 2^2 = 4
260 !
270 Std_event_reg=32+16+8+4
280 !
290 ! Set up the Standard Event Status Enable Register to generate the
300 ! Summary Message
310 !
320 OUTPUT Inst_address;"*ESE";Std_event_reg
330 !
340 ! 2) Calibration Status Register Group
350 ! Condition register conditions which will set the Summary Message
360 ! TRUE if they occur:
370 ! Bit 4: TX Auto-zero failed decimal value = 2^4 = 16
380 ! Bit 3: Voltmeter Self-cal failed decimal value = 2^3 = 8
390 ! Bit 2: Counter Self-cal failed decimal value = 2^2 = 4
400 ! Bit 1: Sampler Self-cal failed decimal value = 2^1 = 2
410 ! Bit 0: Spec Anal Self-cal failed decimal value = 2^0 = 1
420 !
430 Calibration_reg=16+8+4+2+1
440 !
450 ! Set the Transition Filters to allow only positive transitions in
460 ! the assigned condition(s) to pass to the Event Register
470 !
480 OUTPUT Inst_address;"STAT:CAL:PTR";Calibration_reg
490 OUTPUT Inst_address;"STAT:CAL:NTR 0"500!
510 ! Set up the Calibration Status Register Group Enable Register to
520 ! generate the Summary Message.
530 !
540 OUTPUT Inst_address;"STAT:CAL:ENAB";Calibration_reg
550 !
560 ! The Calibration Status Register Group Summary Message is passed to
570 ! the Status Byte Register through Bit 8 in the Questionable
580 ! Data/Signal Register Group Condition Register. The Questionable
590 ! Data/Signal Register Group must be configured to set its Summary
600 ! Message TRUE if the Summary Message from the Calibration Status
610 ! Register Group is TRUE. Therefore Bit 8 (2^8=256) in the Questionable
```

Chapter 10, Controlling Program Flow

Controlling Program Flow Procedure

```
620 ! Data/Signal Register Group Enable Register must be set HIGH.
630 !
640 OUTPUT Inst_address;"STAT:QUES:ENAB 256"
650 !
660 ! 3) Hardware Status Register #1 Group
670 ! Condition register conditions which will set the Summary Message
680 ! TRUE if they occur:
690 ! Bit 5: Measurement limits exceeded decimal value = 2^5 = 32
700 ! Bit 4: Power-up Self-test failed decimal value = 2^4 = 16
710 ! Bit 3: Overpower protection tripped decimal value = 2^3 = 8
720 !
730 Hardware1_reg=32+16+8
740 !
750 ! Set the Transition Filters to allow only positive transitions in
760 ! the assigned condition(s) to pass to the Event Register
770 !
780 OUTPUT Inst_address;"STAT:HARD1:PTR";Hardware1_reg
790 OUTPUT Inst_address;"STAT:HARD1:NTR 0"
800 !
810 ! Set up the Hardware Status Register #1 Group Enable Register to
820 ! generate the Summary Message.
830 !
840 OUTPUT Inst_address;"STAT:HARD1:ENAB";Hardware1_reg
850 !
860 ! 4) Set the correct Summary Message bit(s) in the Service Request
870 ! Enable Register to generate a Service Request (SRQ) if the
880 ! Summary Message(s) become TRUE.
890 ! Bit 5 = Standard Event Status Register Summary Message
900 ! decimal value = 2^5 = 32
910 ! Bit 3 = Questionable Data/Signal Register Group Summary Message
920 ! decimal value = 2^3 = 8
930 ! Bit 0 = Hardware Status Register #1 Group Summary Message
940 ! decimal value = 2^0 = 1
950 !
960 Srq_enab_reg=32+8+1
970 OUTPUT Inst_address;"*SRE";Srq_enab_reg
980 !
990 ! 5) Set up the Active Controller to respond to an SRQ interrupt:
1000 ! Call subprogram Check_interrupt if an SRQ condition exists on select
1010 ! code 7. The interrupt priority level is set to 15 (highest level).
1020 !
1030 ON INTR 7,15 CALL Srvice_interupt
1040 !
1050 ! 6) Enable interrupts on select code 7:
1060 ! The interface mask is set to a value of 2 which enables interrupts on
1070 ! the HP-IB bus when the SRQ line is asserted.
1080 !
1090 ENABLE INTR 7;2
1100 !
1110 ! Start of the dummy loop:
1120 !
1130 LOOP
1140 DISP "I am sitting in a dummy loop."
1150 END LOOP
1160 !
1170 END
1180 !
1190 Srvice_interupt:SUB Srvice_interupt
1200 !
1210 OPTION BASE 1
1220 COM /Io_names/ INTEGER Inst_address,Std_event_reg,Calibration_reg
```

```
1230     COM /Io_names/ INTEGER Hardware1_reg,Srq_enab_reg,Status_byte,Event_reg
1240     !
1250     !Turn off interrupts while processing the current interrupt.
1260     OFF INTR 7
1270     !
1280     !Conduct a SERIAL POLL to read the Status Byte and clear the SRQ:
1290     !
1300     Status_byte=SPOLL(Inst_address)
1310     !
1320     ! Determine which Register Group(s) caused the interrupt. Since three
1330     ! were enabled, all three must be checked:
1340     !
1350     IF BIT(Status_byte,5) THEN GOSUB Srvice_std_evnt
1360     IF BIT(Status_byte,3) THEN GOSUB Srvice_calib
1370     IF BIT(Status_byte,0) THEN GOSUB Srvice_hard1
1380     !
1390     ! Re-enable the interrupt before leaving the service routine
1400     !
1410     ENABLE INTR 7;2
1420     SUBEXIT
1430     !
1440 Srvice_std_evnt:!
1450     ! This routine would determine which bit(s) in the Standard Event
1460     ! Status Register are TRUE, logic 1, and take appropriate action.
1470     ! NOTE: Read the Event Register to clear it. If the Event Register is
1480     ! not cleared it will NOT latch another event, thereby preventing
1490     ! the HP 8920B from generating another SRQ.
1500     !
1510     OUTPUT Inst_address;"*ESR?"
1520     ENTER Inst_address;Event_reg
1530     RETURN
1540     !
1550 Srvice_calib:!
1560     ! This routine would determine which bit(s) in the Calibration Status
1570     ! Register Group Event Register are TRUE, logic 1, and take
1580     ! appropriate action.
1590     ! NOTE: Read the Event Register to clear it. If the Event Register is
1600     ! not cleared it will NOT latch another event from the Condition
1610     ! Register, thereby preventing the HP 8920B from generating another SRQ.
1620     !
1630     OUTPUT Inst_address;"STAT:CAL:EVEN?"
1640     ENTER Inst_address;Event_reg
1650     RETURN
1660     !
1670 Srvice_hard1:!
1680     ! This routine would determine which bit(s) in the Hardware Status
1690     ! Register #1 Group Event Register are TRUE, logic 1, and take
1700     ! appropriate action.
1710     ! NOTE: Read the Event Register to clear it. If the Event Register is
1720     ! not cleared it will NOT latch another event from the Condition
1730     ! Register, thereby preventing the HP 8920B from generating another SRQ.
1740     !
1750     OUTPUT Inst_address;"STAT:HARD1:EVEN?"
1760     ENTER Inst_address;Event_reg
1770     RETURN
1780     !
1790 SUBEND
```

Protocol Logging

The CDMA protocol logging feature allows the capture of over-the-air forward and reverse IS-95A messages on the traffic channel or paging/access channel.

This logging feature is intended to be used as a low-level tool to aid the advanced user in debugging new phone designs or qualifying the operation of new mobile stations.

CAUTION:

Operation and setting changes made using the information contained in this module can negatively affect system operation. Hewlett-Packard makes no claim or warranty of proper operation or fitness of use when the user has altered the operation of the unit using these techniques.

Hardware and Software Requirements

Using the protocol logging functions of the Test Set requires a number of specific hardware and software items not supplied directly by Hewlett-Packard. It is the user's responsibility to acquire those items not provided by Hewlett-Packard.

CAUTION:

Attempting to use hardware and software items other than those specified in this module may result in unsatisfactory performance. Hewlett-Packard does not make any claims of suitability as to the form and/or function of such substitutions.

Hardware Requirements

Three pieces of hardware, besides the Test Set and mobile station, are required to use the protocol logging functions of the Test Set.

- An industry standard PC compatible computer¹
- Break-out Adapter HP P/N 08924-61029 (37 pin "D" connector to two 9-pin and one 15-pin "D" connectors)

The break-out adapter is shipped as standard equipment with the Test Set.

- A null-modem cable, no more than six feet in length.

The null-modem cable is not provided by Hewlett-Packard, but is a readily available standard serial cable. The end of the null-modem cable that mates to the Test Set (break-out adapter) will be a nine-pin male sub-miniature "D". The end that connects to the computer will be a nine-pin female male sub-miniature "D" or a 25-pin sub-miniature "D", depending on the computer. The User Manual for PROCOMM PLUS² (see ["Software Requirements" on page 336](#)) shows diagrams for making a null-modem cable from an RS-232 cable.

1. The computer should be equipped with a buffered 16550 UART (Universal Asynchronous Receiver/Transmitter). This will allow serial communication even if the processor is busy and cannot immediately handle the serial port interrupt requests. A 486 33MHz class microprocessor is adequate, but a 586 100 MHz class processor will reduce the likelihood of missed characters sent from the Test Set.
2. PROCOMM PLUS is a product of Datastorm Technologies, Inc.

Software Requirements

The computer must have a communications software package installed that is capable of the following:

- Handling a null modem serial connection
- Supporting a baud rate of 115 kbps
- Emulating a VT 100 terminal.

The following communications packages have been tested and verified to work for protocol logging:

- PROCOMM PLUS version 2.01 for MS-DOS from Datastorm Technologies, Inc. running with MS-DOS version 2.0 or later (Hewlett-Packard recommends MS-DOS version 6.22).
- HyperTerminal (comes with Windows 95). Hewlett-Packard recommends a 486 66 MHz class microprocessor and 16 MBytes of RAM for Windows 95.

Connecting the Test Set to the Computer

CAUTION:

Be sure that a null-modem cable connected to the Test Set is never left unterminated. It must remain connected to the computer's serial port. Because data on the protocol logging connectors is transferred at a very high speed, an unterminated or poor quality null-modem cable could generate internal cross talk, causing the Test Set to behave erratically and possibly crash.

1. Install the break-out adapter.

1. Remove the metal cover plate from the Cell Site/ Triggers rear-panel connector, if one is present.
2. Attach the break-out adapter to the Cell Site/ Triggers connector.
3. Do not over tighten the attaching screws.

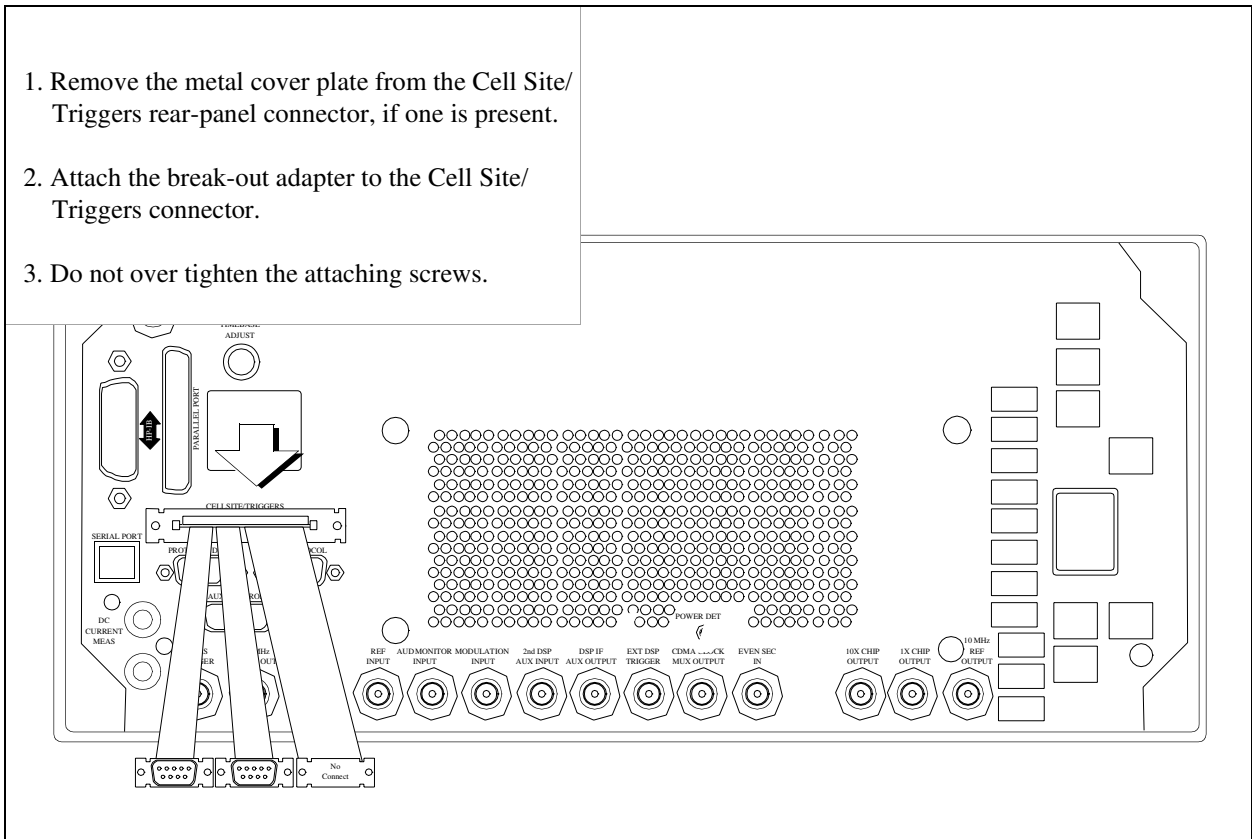

2. Make the connection between the Test Set and the computer.

1. Connect one end of the null-modem cable to Logging Port 1 on the break-out adapter.
2. Connect the other end of the null-modem cable to the serial port on the computer.

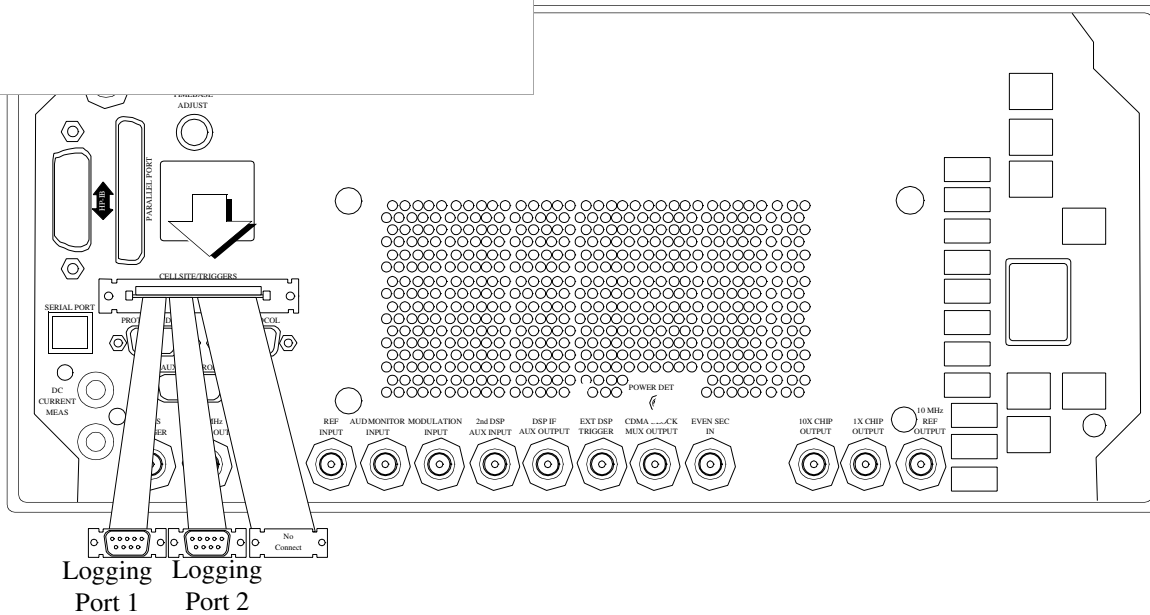

Logging Port 1 outputs signaling that occurs on the forward and reverse traffic channels.

Logging Port 2 outputs signaling that occurs on the forward paging channel and reverse access channel.

The computer's serial port will likely be a nine-pin female sub-miniature "D", or a 25-pin female sub-miniature "D" connector.

Buffered UART (16550) must be installed in computer.

Setting Up the Communications Package

This section will provide the general settings for configuring a communications package for protocol logging with the Test Set. If you are using PROCOMM PLUS, detailed setup information for installing or reconfiguring PROCOMM PLUS is provided.

General Setup Parameters

- *Baud Rate.....115,200*
- *Parity.....None*
- *Data Bits.....8*
- *Stop Bits.....1*
- *Terminal Emulation...VT100*

Installing PROCOMM PLUS

The following list includes the setup information that PROCOMM PLUS version 2.01 for MS-DOS from Datastorm Technologies, Inc. will prompt you for during installation.

PROCOMM PLUS Prompt Settings

- Prompt: How will you use PROCOMM PLUS?
Choose: With a Direct Connection Only
- Prompt: COM Ports
Choose: Available serial port
- Prompt: Baud Rates
Choose: 115200
- Prompt: Communication Settings
Choose: No Parity, 8 data bits (Required for Test Set)
- Prompt: TERMINAL FAMILY
Choose: VT/AMSI (Required for Test Set)
- Prompt: DEFAULT TERMINAL EMULATION
VT100 (Required for Test Set)
- DEFAULT DOWNLOAD PROTOCOL
XMODEM (Required for Test Set)

Reconfiguring PROCOMM PLUS

If you already have PROCOMM PLUS installed on your computer, use the settings listed in the following steps to insure proper setup.

1 Start PROCOMM PLUS

- At the DOS prompt change directories to where you installed PROCOMM PLUS.
- Type pplus, and press ENTER.
- Press any key to enter PROCOMM PLUS terminal mode.

2 Set Up "TERMINAL OPTIONS".

- While holding down the ALT key, press the S key.
This displays the PROCOMM PLUS SETUP UTILITY...MAIN MENU.
- Select "TERMINAL OPTIONS" from the list of choices.
This displays the PROCOMM PLUS SETUP UTILITY...TERMINAL OPTIONS.
- Follow the on screen directions for changing the settings.
A-Terminal emulation..... VT100
B- Duplex..... FULL
- Esc: Exit back to PROCOMM PLUS SETUP UTILITY...MAIN MENU.

3 Set Up "HOST MODE OPTIONS".

- Select "HOST MODE OPTIONS" from the list of choices.
- Follow the on screen directions for changing the setting for D- Connection Type to "DIRECT".
- Esc: Exit back to PROCOMM PLUS SETUP UTILITY...MAIN MENU.

4 Save the current settings to the PROCOMM PLUS Software.

- Select "SAVE SETUP OPTIONS" from the list of choices.
Esc: Exit back to PROCOMM PLUS SETUP UTILITY...MAIN MENU.

5 Configure the computer's serial port.

- While holding down the ALT key, press the P key.

This displays the LINE/PORT SETUP screen.

- Type, next to the prompt "YOUR CHOICE", the characters that correspond to the following parameters:

BAUD RATE= 115200

PARITY = None

DATA BITS = 8

STOP BITS = 1

PORT = Available serial port

- Save the current settings to the PROCOMM PLUS Software (ALT S keys).

6 Verify serial communication with the Test Set.

- Apply power to the Test Set.

As the Test Set is going through its power-up cycle, messages should appear.

- Press the Enter key on your computer.
- If setup is correct, a prompt will be echoed back from the Test Set to the computer's screen.

DCS1> If serial port COM1 1 is selected

DCS2> If serial port COM2 is selected

Logging Protocol Messages

With PROCOMM PLUS configured correctly, the Test Set will display protocol messages on the computer display through the serial null-modem cable, which may be connected to Logging Port 1 or Logging Port 2 on the break-out adapter.

Logging Port 1 will provide all over-the-air messages sent by the Test Set on the Sync Channel and traffic channel messages sent and received by the Test Set on the forward and reverse traffic channels.

Logging Port 2 will provide all over-the-air messages sent on the paging channel and received by the Test Set on the access channel. By system default, certain paging channel messages that are continuously repeated (those which are not intended for a specific mobile station) are not displayed. These include the System Parameters Message, Access Channel Parameters Message, Channel List Message, Extended System Parameters Message, and the Extended Neighbor List Message. The "o" command, (see "[Logging Port 2 Commands](#)" on page 348) allows you to turn on or turn off these messages.

Along with protocol messages, PROCOMM PLUS (in its default mode) will also display:

- Internal control messages from the Test Set
- Frame-rate indicators for forward and reverse traffic channels

The following [example log](#) shows typical data that might be logged from Logging Port 1.

Table 6 Forward Channel Frame Rate Characters

	Frame Rate Indicators for Forward Channel (to mobile station)			
8 kbps*	'1' = full	'2' = half	'3' = quarter	'4' = eighth
13 kbps	'5' = full	'6' = half	'7' = quarter	'8' = eighth
* '0' = Corrupt frame				

Table 7 Reverse Channel Frame Rate Characters

	Frame Rate Indicators for Reverse Channel (to mobile station)			
8 kbps *	'F' = full 'f' = full rate likely	'-' = half	'_' = quarter	'.' = eighth
13 kbps	'S' = full 's' = full rate likely	' ' = half	'^' = quarter	':' = eighth
* ' ' = corrupt frame				

Capturing a Log to a File on the Computer

PROCOMM PLUS provides a capture mode that, when activated, stores all data to a file of your choice for further evaluation.

- 1 To begin logging, hold down the Alt key on the computer, press F1.

You will be prompted to provide a filename.

- 2 Type in a filename for the captured log.
- 3 When you have completed logging, hold down the ALT key and press F1.

The status bar at the bottom of the computer's display will indicate that the log has been closed.

- 4 You can evaluate the contents of your file now with any text editor.

Control Commands for Protocol Logging

Control commands allow modification to the protocol logging feature through the computer running the communications package (see ["Software Requirements" on page 336](#)). All commands are sent by typing a single character on the computer keyboard.

The menu of commands is displayed by typing a "?" (SHIFT, \).

Logging Port 1 Commands

NOTE:

A list of these commands can be displayed by pressing "?" on the computer keyboard.

"a" Pressing the "a" key on the computer keyboard causes the Test Set to display the active parameters for the access channel.

"b" For internal Hewlett-Packard use only.

"c" Pressing the "c" key on the computer keyboard causes the Test Set to display its current CDMA channel parameters, such as Walsh code assignments and PN offsets. This information is settable on the CDMA GENERATOR CONTROL screen.

"d" Pressing the "d" key on the computer keyboard causes the computer to display compressed forward and reverse traffic channel data in hexadecimal format. Data is preceded by a code that indicates the frame data rate, and whether it was received (Rx) or transmitted (Tx). Refer to ["Forward Channel Frame Rate Characters" on page 344](#) and ["Reverse Channel Frame Rate Characters" on page 344](#) for the meaning of each code.

CAUTION:

During a call, traffic data is continually sent and received by the Test Set. Pressing the "d" key will cause the computer to log a tremendous amount of data. Pressing the "d" key again stops the display of data.

"e" For internal Hewlett-Packard use only.

"f" For internal Hewlett-Packard use only.

"i" For internal Hewlett-Packard use only.

"l" It is not recommended that you use this command. This command toggles power control mode. A field on the CDMA TRANSMITTER POWER RANGE TEST screen, Closed Loop Pwr Cntl, should be used to perform this function.

"m" For internal Hewlett-Packard use only.

"o" Pressing the "o" key will toggle a command mode that logs all sync channel overhead messages. Sync channel messages are continually sent by the Test Set, so be prepared for a large amount of data. Press "o" again to disable.

"p" Pressing the "p" key will toggle a command mode that logs a "D" for each down power control bit, and a "U" for each up power control bit. A power control bit is transmitted every 1.25 mS, so be prepared for a large amount of data. Press "p" again to disable.

"q" For internal Hewlett-Packard use only.

"r" For internal Hewlett-Packard use only.

"s" Pressing the "s" key will display the current parameters being used on the Sync Channel.

"t" Pressing the "t" key will display the current parameters being used on the Traffic Channel.

"u" For internal Hewlett-Packard use only.

"v" For internal Hewlett-Packard use only.

"w" For internal Hewlett-Packard use only.

"y" Pressing the "y" key will display the current parameters used on the system overhead messages.

"+" For internal Hewlett-Packard use only.

"-" For internal Hewlett-Packard use only.

", " Pressing the ", " key will toggle a command mode that displays the Frame Rate Characters (see ["Forward Channel Frame Rate Characters" on page 344](#) and ["Reverse Channel Frame Rate Characters" on page 344](#)). Toggling frame rate indicators off greatly reduces the amount of data logged.

". " Pressing the ". " key will toggle a command mode that displays a subset of the the Test Set's internal control messages, called Status Request Messages. Turning Status Request Messages off makes it easier to analyze protocol-related data.

Logging Port 2 Commands

NOTE: A list of these commands can be displayed by pressing "?" on the computer keyboard.

"a" Pressing the "a" key on the computer keyboard causes the Test Set to display the active parameters for the access channel.

"b" For internal Hewlett-Packard use only.

"c" Pressing the "c" key on the computer keyboard causes the Test Set to display its current CDMA channel parameters, such as Walsh code assignments and PN offsets. This information is settable on the CDMA GENERATOR CONTROL screen.

"f" For internal Hewlett-Packard use only.

"i" For internal Hewlett-Packard use only.

"m" Pressing the "m" key on the computer keyboard causes the Test Set to display the monitored parameters on the Access Channel. If the Test Set has detected access probes, this command will show if the information was good or bad via the message CRC counters.

"o" Pressing the "o" key will toggle a command mode that logs all sync channel overhead messages. Sync channel messages are continually sent by the Test Set, so be prepared for a large amount of data. Press "o" again to disable.

"p" Pressing the "p" key will display the current parameters being used on the Paging Channel.

"q" For internal Hewlett-Packard use only.

"s" Pressing the "s" key will display the current parameters being used on the System Overhead Message.

"t" Pressing the "t" key will display System Time.

"**u**" For internal Hewlett-Packard use only.

"**v**" For internal Hewlett-Packard use only.

"**w**" For internal Hewlett-Packard use only.

"**.**" Pressing the "." key will toggle a command mode that displays a subset of the the Test Set's internal control messages, called Status Request Messages. Turning Status Request Messages off makes it easier to analyze protocol-related data.

Symbols

"Enable timer-based registration." on
page 148, 221
*RST, 52

Numerics

32768, 60
600 ohm impedance, 270

A

access attempts, ignoring, 189
access parameters message, 156, 193
access probe output power measurements, 186
programming example, 197
address, HP-IB, 261
alert order, 291
amplitude error measurements, 141
programming example, 148
analog system type, 204
arm measurement, 81
authentication, 296
list of tests, 212, 240
authentication tests
initializing shared secret data to zero, 213
performing a unique challenge-response, 230
shared secret data update on a traffic channel, 227, 233, 235, 236
updating shared secret data, 222
AUX CONTROL connector, 53
average power measurements
selecting, 39
zeroing procedure, 36

C

cable loss
 correcting for, 41
 measuring, 44
calibrating
 See also zeroing
calibration
 recommendations, for channel levels, 26
 recommendations, for channel power, 29
 recommendations, for RF generator levels, 35
 recommendations, for zeroing average power, 36
 recommendations, overall, 25
call
 mobile originated, 64, 235
 mobile terminated, 63
 origination (analog call processing), 290
call drop timer, 165
Call Processing (analog)
 Status Register Group, program flow control, 281
call processing (analog)
 general procedure, 270
 overview, 265
 screen, description of, 267
 state diagram, 266
Call Processing Subsystem (analog)
 accessing, 277
 command syntax, 278
 error messages, reading, 280
 first-time setup, 279
 overview, 276
 querying data messages, 282
 screen mnemonics, 277
 state diagram, 276
carrier feedthrough measurements, 141
 programming example, 148
carrier frequency, 118
CDMA status register group
 reporting structure, 320
 SMB, 322
 transition filters, 321
CDMA to analog handoff, 200
 programming example, 208

channel
 selecting, 56
channel level calibration
 programming example, 27
channel numbers
 EIA/TIA IS-95A, 69
channel power measurements
 programming example, 33
configuration
 analog call processing, 293
 for analog call processing, 286
continuous 0 power control bits, 159
continuous 1 power control bits, 169
control channel
 turning on for analog call processing, 287
control channel (analog)
 turning on, 294
controlled output power measurements, 164

D

data rate
 paging channel, 129
 Service Option 2, 79
 Service Option 9, 79
data structure
 for status reporting, 320
dBm/BW
 definition, 57
default settings
 HP-IB syntax for setting, 52
demodulation
 forward traffic channel, 73
 slotted mode paging channel in AWGN, 128
desensitization, single tone, 99
drop timer, 165
duplexer, external, 54
dynamic range measurement, 87
 programming example, 96

E

Eb/Nt
 resolution of reading, [77](#)
Ec/Ior
 Sector A Power, default value, [75](#)
external controller, [260](#)

F

FER
 specification, [78](#)
 status bits, [82](#)
frame error rate. *See* FER.
frame rate characters
 forward channel, [344](#)
 reverse channel, [344](#)
frequency error measurements, [141](#)
 programming example, [148](#)

H

handoff
 CDMA to analog, [200](#)
 mobile station to new voice channel
 (analog call processing), [289](#)
 parameters, [205](#)
 verification, [207](#)
HP-IB
 address, [261](#)
 external control, [260](#)
HP-IB/Ser switch setting for PCS mode,
 [53](#)
hum and noise
 measurement, [314](#)

I

ignore access attempts, 189
impedance
 600 ohms, 270
 input, for analog call processing, 270
 output, for call analog processing, 270
Init Power parameter, 156, 193
intemodulation spurious response attenuation measurement, 115
interim test results, 80
interrupt
 enabling, 324
 servicing, 327
Ioc
 definition, 76
Ior/Ioc
 definition, 130
IS-95A
 CDMA channel numbers, 69
 protocol selection, 55

L

load impedance, 270
loading ROM program
 HP-IB syntax for, 27
logging, CDMA protocol, 333
loopback mode
 data, 60
 voice, 60

M

Max Req Seq parameter, 156
Max Rsp Seq parameter, 156, 193
maximum power measurements, 150
 RF output power, 154
maximum RF output power measurements
 programming example, 162
measurements
 amplitude error, 141
 carrier feedthrough, 141
 demodulation of forward traffic channel with AWGN, 73
 demodulation of slotted mode paging channel in AWGN, 128
 dynamic range, 87
 frequency error, 141
 hum and noise, 314
 intermodulation spurious response attenuation, 115
 phase error, 141
 power, access probe, 186
 power, maximum, 150
 power, maximum RF output, 154
 power, minimum, 150
 power, minimum controlled output, 164
 power, range of open loop output, 175
 receiver sensitivity (CDMA), 87
 RF sensitivity (analog), 313
 rho, 141
 single tone desensitization, 99
 time offset, 141
 waveform quality, 141
MER
 definition, 128
MER (message error rate)
 calculation, 136
message
 changing contents, 311
 logging, CDMA protocol, 333
 viewing decoded words from mobile station handoff, 304
 viewing decoded words from mobile station origination, 307
 viewing decoded words from mobile station page, 302
 viewing decoded words from mobile

station registration, [301](#)
viewing decoded words from mobile
station release, [305](#)
viewing decoded words from order to
change TX power of mobile, [306](#)
message error rate. *See* MER.
MIN
MS id, [295](#)
minimum controlled output power mea-
surements
programming example, [172](#)
minimum power measurements, [150](#)
controlled output power, [164](#)
MSUT
definition, [55](#)

N
no service
troubleshooting, [68](#)
Nom Power parameter, [156](#), [193](#)
Num Step parameter, [156](#), [193](#)

O
open loop output power (range) measure-
ments
programming example, [184](#)
open loop output power range, [175](#)
operation status register group, [320](#)
SMB, [323](#)
origination, call (analog), [290](#)

P

PAG_1 parameter, 133
 PAG_2 parameter, 133
 PAG_4 parameter, 133
 paging
 mobile station (analog), 296
 mobile station for analog call processing, 288
 paging channel
 data rate, 129
 PCB_CAL, 27
 PCS Interface, 53
 PCS mode, 53
 phase error measurements, 141
 programming example, 148
 phone number
 MS Id, 295
 pilot Ec/Ior
 factory preset value, 75
 polling versus SRQ interrupts, 318
 power
 mobile station transmitted, 290
 power control bits
 continuous 0, 159
 continuous 1, 169
 power measurements
 access probe output power, 186
 maximum closed/open loop, 150
 maximum RF output, 154
 minimum closed/open loop, 150
 minimum, controlled output, 164
 range of open loop output power, 175
 power meter
 RF, zeroing for analog call processing, 285
 Power Step parameter, 156, 193
 power-up registration, 61
 presetting Test Set, 52
 HP-IB syntax for, 52
 primary CDMA channel
 System A, 56
 System B, 56
 programming example
 access probe output power measurement, 197
 amplitude error measurements, 148
 carrier feedthrough measurements, 148
 CDMA channel level calibration, 27

CDMA to analog handoff, 208
 channel power calibration, 33
 demodulation of forward traffic channel with AWGN measurement, 83
 dynamic range measurement, 96
 frequency error measurements, 148
 maximum RF output power measurements, 162
 minimum controlled output power measurements, 172
 open loop output power (range) measurements, 184
 phase error measurements, 148
 receiver sensitivity measurement, 96
 RF generator level calibration, 35
 rho measurements, 148
 single tone desensitization measurement, 111
 SRQ interrupt, 329
 time offset measurements, 148
 waveform quality measurements, 148
 protocol, 55
 protocol logging, 333
 commands, 345
 example log, 343

Q

querying
 amplitude error measurement, 146
 calibrating status event register, 33
 carrier feedthrough measurement, 146
 CDMA status event register, 62
 CDMA status register group event register, 126
 Eb/Nt, 77
 frequency error measurement, 146
 phase error measurement, 146
 rho measurement, 146
 time offset measurement, 146

R

range of open loop output power measurements, 175
 programming example, 184
 receiver sensitivity measurement
 programming example, 96
 receiver sensitivity measurement (CDMA), 87
 receiver tests
 demodulation of forward traffic channel with AWGN, 73
 demodulation of slotted mode paging channel in AWGN, 128
 dynamic range, 87
 intermodulation spurious response attenuation, 115
 list of, 72
 receiver sensitivity (CDMA), 87
 single tone desensitization, 99
 registration
 of mobile station, 61
 of mobile station for analog call processing, 287
 power up, 62
 troubleshooting failures, 70
 release
 mobile station, 289
 reset. *See* presetting instrument
 RF channel
 selecting, 56
 setting for home system, 68
 setting for system A, 68
 setting for system B, 68
 RF channel standard, 55
 RF generator level calibration
 procedure, 35
 programming example, 35
 RF output power measurements, 154
 RF path loss
 correcting for, 41
 measuring, 44
 rho measurements, 141
 programming example, 148
 *RST, 52
 running ROM program, 28
 HP-IB syntax for, 28

S

SAT tolerance, wide, 202
 Sector A Power
 Ec/Ior, default value, 75
 setting, 57
 sensitivity
 RF, measuring (analog), 313
 sensitivity, receiver (CDMA), 87
 service option
 selecting, 60
 Service Option 2
 data rate, 79
 Service Option 9
 data rate, 79
 service request interrupts. *See* SRQ.
 shared secret data
 initializing to zero, 213
 updating, 222
 shared secret data update
 traffic channel, 227, 233, 235, 236
 short message service
 Sending short messages on the Paging/Access channels, 241
 sending short messages on the Traffic channels, 250
 SID, 68
 single tone desensitization measurement, 99
 programming example, 111
 slotted mode paging channel demodulation, 128
 SMB
 for CDMA status register group, 322
 for operation status register group, 323
 reporting structure, 319
 SMS tests
 sending short messages on the Paging/Access channels, 241
 sending short messages on the Traffic channels, 250
 spurs, 115
 SRQ
 programming example, 329
 SRQ interrupt
 enabling, 324
 overview, 318
 SSD
 see shared secret data, 213, 222, 227,

233, 235, 236
 status byte register group, 320
 status message bit. *See* SMB.
 status reporting. *See* the HP 8924C User's Guide.
 System A
 primary CDMA channel for EIA/TIA IS-95, 56
 System B
 primary CDMA channel for EIA/TIA IS-95, 56
 system type, analog, 204

T

time offset measurements, [141](#)
 programming example, [148](#)
tolerance, SAT, [202](#)
Traffic Ec/Ior
 definition, [75](#)
transmitter tests
 list of, [140](#)
 waveform quality, [141](#)
troubleshooting
 no service found, [68](#)
 registration failures, [70](#)

U

unique challenge-response, [230](#)

W

waveform quality measurements
 list of, [141](#)
 programming example, [148](#)
wide SAT tolerance, [202](#)
word
 decoded from mobile station handoff,
 [304](#)
 decoded from mobile station origina-
 tion, [307](#)
 decoded from mobile station page, [302](#)
 decoded from mobile station registra-
 tion, [301](#)
 decoded from mobile station release,
 [305](#)
 to view, from order to change TX pow-
 er of mobile, [306](#)

Z

zeroing

- average power measurements, [36](#)
- recommendations, for average power, [36](#)
- RF power meter for analog call processing, [285](#), [292](#)