

QUICK REFERENCE GUIDE

**HP 8902A
MEASURING
RECEIVER**

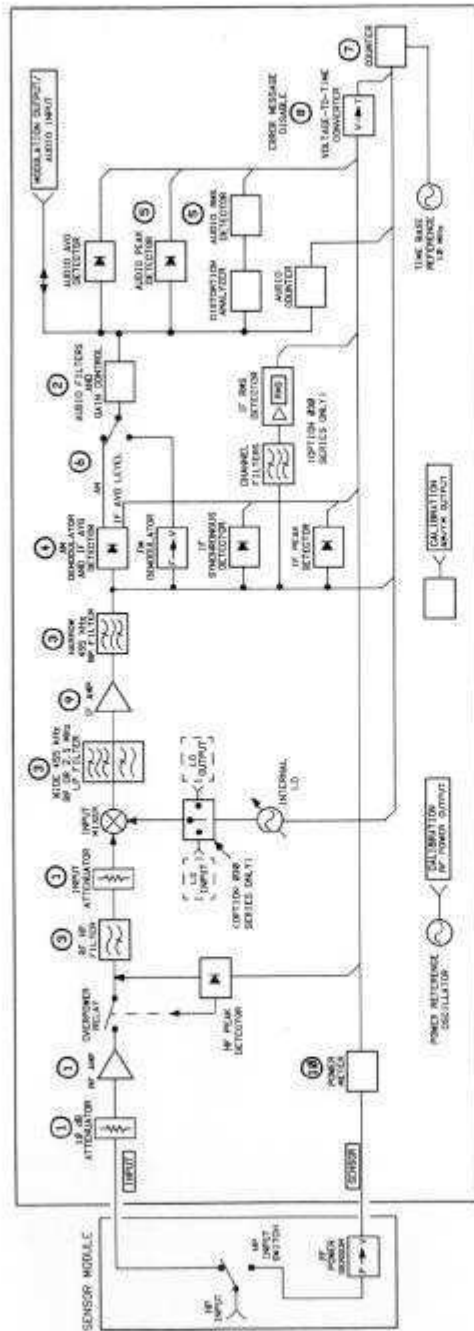



1. RF Input Attenuation and Gain

	RF Attenuation (dB)	RF Gain (dB)	AUTO*						
AUTO	0	10	20	30	40	50	14		
1.0	1.1	1.2	1.3	1.4	1.5	1.6	1.7	1.8	1.9

* Automatic selection 10 dB attenuator always inserted (Tuned RF Level only).

6. Automatic Level Control*

	Slow	Fast
AM > 20 HZ	6.0	6.1
AM > 1 KHZ		6.2

* Except Tuned HF Level

2. Audio Range

Modulation	RMS	Detector	
		PK, Ave, RMS	
AM (% PK)	Auto	40	100
FM (kHz, pk)*	4.0	4	40
FM (kHz, pk)*	0.4	4	400
FM (rad, pk)	2.0	2.1 (2.4)	2.2
			2.3

* Divide-by-10 with 750 μ s FM DE-EMPHASIS and PRE-DISPLAY.

3. RF and IF Filters

IF FREQ	455 kHz	1.5 MHz
Wide Filter	200 kHz	2.5 MHz
Narrow Filter	30 kHz	Bandwidth
RF HP Filter Out	3.6	3.5
RF HP Filter In	3.8	3.7
		Narrow Filter Out
		3.1
		3.3
		3.4

4. Tuned RF Level Detector Selection and Display Averaging

Detector	IF Synchronous	IF Average
Measurement	AUTO	10
Averaging Time(s)	4.0	4.1
	4.2	4.3
	4.4	4.5
	4.6	4.7

5. Audio Detector Response

Audio Peak Detector Response and RMS Detector Digital Averaging Response:

Fast	Slow
5.0	5.1

7. RF Frequency Resolution

AUTO	10 Hz	100 Hz	1 kHz	1 Hz
7.0	7.1	7.2	7.3	7.4

8. Error Message Disable and Enable

Auto	Disable Errors				All Errors Enabled
	01	02	03	04	
8.0	8.1	8.2	8.3	8.4	8.5
					8.6
					8.7
					8.8

9. IF Gain

Auto	0	10	20	30	40	50	60
9.0	9.1	9.2	9.3	9.4	9.5	9.6	9.7

10. RF Power Range

Auto	Most Sensitive Range					Least Sensitive Range				
	#1	#2	#3	#4	#5	#1	#2	#3	#4	#5
10.0	10.1	10.2	10.3	10.4	10.5	10.6	10.7	10.8	10.9	11.0

11. Previous Ratio

11.2 Display previous ratio reference.

12/13. Calibration FM, AM

	Display Peak FM	Display Peak AM
Computed	12.0	13.0
Residual	12.1	13.1
Measured	12.2	13.2

14. Limit

14.0 Disable

14.9 Display limit status: Lower limit status. Upper (0=disabled, 1=enabled).

	Lower Limit	Upper Limit
Set to Ratio		
Reference	14.1	14.2
Enable	14.3	14.4
Display	14.5	14.6
Display		
Measurement Code	14.7	14.8

15. Time Base Check

15.0 Displays Error 12 if Option 002 is installed and oven is cold. Displays 0 if Option 002 is installed and oven is warm, or if Option 002 is not installed.

15.1 Displays 0 if internal time base is being used. Displays 1 if external time base is being used.

16. Calibration Factors: AM,

17. Calibration Factors: FM

	AM Cal Factor	FM Cal Factor
Disable	16.0	17.0
Enable	16.1	17.1
Display	16.2	17.2

18. Tone-Burst Receiver

18.NN Configures instrument as a tone-burst receiver. A time delay of NN ms is inserted between detection of a carrier and unsquelching of the output at MODULATION OUTPUT/AUDIO INPUT. Range of NN is 1 to 99 ms. If NN is 0, delay is 99 ms.

21. HP-IB Address

21.0 Displays HP-IB address in form AAAAAA.TLS

AAAAAAA = binary address

T = 1 = talk only

L = 1 = listen only

S = 1 = requesting service

22. Service Request

22.NN A value of NN from 0 to 63 sums the weighted conditions below to set up a service request mask. The summed, weighted conditions are displayed when NN is 64.

1 Data Ready

2 HP-IB error (Cannot be disabled.)

4 Instrument error

8 Limit exceeded

16 Frequency Offset mode state change

32 Recal or Uncal

64 Read back SRQ mask

23. External LO (Option 030 Only)

23.0 Return the LO to internal.

23.1 Set the LO to external.

23.2 Display LO status: (0 = Internal, 1 = External)

24. Selective Power Measurement (Option 030 Only)

24.0 Sets the Measuring Receiver to the Selective Power Measurement Mode.

	Select	Establish 0 dB Ref.	Display Normalize Noise Meas.
Wide BW IF Filter (Adjacent-Channel, Cellular)	24.1	24.2	
Narrower BW IF Filter (Adjacent-Channel)	24.3	24.4	
Narrowest BW IF Filter (Single-Sideband Noise)	24.5	24.6	24.7

24.8 Sets the value of the noise measurement BW.

24.9 Display the value of the noise measurement BW.

25. External Attenuation (dB)

25.2 Display attenuation value.

26. Set Reference

- 26.0 Exit attenuator measurement
- 26.1 Re-enter attenuator measurement

27. Frequency Offset Control

Frequency Offset Mode		External LO	
Exit	Re-enter	Display	Enter/Enable
27.0	27.1	27.2	27.3

29/30. Other Audio Measurement Modes

- 29.0 SINAD
- 30.0 EXT AUDIO RMS LEVEL

31. Tuned RF Level Noise Correction

- 31.0 Turn off noise correction.
- 31.1 Turn on noise correction.
- 31.2 Display noise correction status (1 = Off, 0 = On).

32. dB and Frequency Resolution

- 32.0 Normal measurement resolution (Power: 0.01 dB resolution) (Audio Frequencies from 100 to 250 kHz; 0.1 Hz resolution).
- 32.1 Increased measurement resolution (Power: 0.001 dB resolution) (Audio Frequencies from 100 to 250 kHz; 0.1 Hz resolution).
- 32.2 Display measurement resolution status. (0 = normal, 1 = increased).

32.9 Tuned RF Level Measurements Using Track-Mode Tuning

1. Input a signal greater than -30 dBm.
2. Select 32.9 SPCL.
3. If using an external LO, enter the external LO frequency in MHz.
4. Select MHz to enter the manual tune mode.
5. Step the signal generator down in amplitude and press the CALIBRATE key whenever the RECAL annunciator is displayed.

33/36. Other Measurement Modes

- 33.0 LO FREQUENCY
- 34.0 IF FREQUENCY
- 35.0 RF LEVEL
- 36.0 PEAK TUNED RF LEVEL

37. Calibration Factors: RF Power

- 37.0 Automatic Cal Factors
- 37.1 Manual Cal Factors
- 37.2 Display Status (0 = auto, 1 = held)
- 37.3 *Enter frequency, cal factor
- 37.4 *Display table size
- 37.5 *Recall reference cal factor
- 37.6 *Recall next frequency, cal factor
- 37.7 *Clear Table

* Two tables are available. The table being used is determined by the status of the Frequency Offset mode (Special Function 27).

38/39. Calibration Factors Tuned RF Level

	RF Power to Range 1	Range 1 to 2	Range 2 to 3	SET REF Reference
Display	38.1	38.2	38.3	38.4
Enter	39.1	39.2	39.3	39.4

- 39.9 Clear all calibration factors.

Frequency Offset (Special Function 27).

The Frequency Offset mode allows the Measuring Receiver to keep track of frequencies involved in the down-conversion process. This frequency offset process is used in conjunction with an external mixer and Local Oscillator (LO) to extend the frequency coverage above 1300 MHz.

To enter the Frequency Offset mode:

2 7 . 3 + SPCL

+ LO Frequency + MHz

To exit the Frequency Offset mode:

2 7 . 0 + SPCL

To re-enter the Frequency Offset mode with the same LO frequency:

2 7 . 1 + SPCL

To display the external LO frequency:

2 7 . 2 + SPCL

Operating Error Codes

Display Code	To Solve an Input Problem	To Solve an Operating Problem
-- or 0 MHz	Adjust input signal level or change measurement sensitivity.	Decrease RF attenuation or gain.
----	Manually tune to input signal.	Re-check operating conditions being used.
-----	Check tuning.	Re-check special operating conditions being used.
01	Increase input signal level or decrease AM.	Press the MHz key to center IF signal in IF passband. If problem persists, signal may be drifting.
02	Increase RF input attenuation.	Decrease RF and/or IF gain setting.
03	Increase level of input signal.	Decrease selected RF input attenuation or increase IF gain. If Range Hold is being used, check range limits.
04	Decrease modulation level on input signal to within measurement range.	Increase range limit setting, Special Function 2.N.
05	Increase carrier level or decrease AM depth (<90%).	
06	Input level exceeds 7 Vrms (1W peak). Decrease level of input signal. If making a TRFL measurement, also press the CLEAR key.	Decrease selected RF or IF gain. If Range Hold is being used, check range limits.
07	Decrease modulation level on input signal. If making a TRFL measurement, decrease level of input signal and press CLEAR key.	Decrease selected RF or IF gain. If Range Hold is being used, check range limits.
08	Check connection to Calibrator. Check for Calibrator malfunction.	
09		Check internal time base for malfunction (Option 002 only).
10	Adjust frequency of input signal to within measurement range, or increase measurement range. If making a TRFL measurement, set the input level to between 0 and -20 dBm. Select the Frequency mode. When the instrument displays the frequency of the input signal, press the MHz key and re-enter the TRFL mode.	

Operating Error Codes

Display Code	To Solve an Input Problem	To Solve an Operating Problem
11	Select linear (Watts) units, or disregard error when there is no power present at sensor input.	Key in a different ratio reference.
12		Wait for oven to warm for highest accuracy.
13	Secure connection at SENSOR input.	
14		Remove power from power sensor input during zeroing process.
15		Verify that cal factors have been entered.
16	Increase audio signal level.	
17	Input signal level during reference measurement must be between 1.25V and 2.50V.	Check selected RF or IF gain level. (When making Ratio measurements, allow instrument to complete the reference measurement.)
18		Check sensor connection at RF POWER OUTPUT port.
19		Increase IF gain.
20		Re-enter frequency within measurement range. (In Ratio mode, a reference measurement of zero is invalid.)
21		Check compatibility of function(s) with selected measurement mode.
22		Check Special Function number and re-enter (prefix invalid).
23		Check Special Function number and re-enter (suffix invalid).
24		Invalid HP-IB code. Check function codes.
25		Check Special Function compatibility with measurement.
26		End of RF Power calibration table. (If displayed after first attempt to read table using 37.6 SPCL, the table is empty.)

Operating Error Codes

Display Code	To Solve an Input Problem	To Solve an Operating Problem
30		Change RF attenuation and gain or Range Hold setting.
31		Calibrate RF Power measurement.
32		Change IF gain or Range Hold setting.
33	Maintain stable frequency and level during calibration. Check SENSOR connection.	Check RF Power calibration.
34	Maintain stable frequency during TRFL calibration.	
35	Use a stable signal source for TRFL calibration.	

Measuring Receiver Function to Code Summary

Function	Code	Function	Code
MEASUREMENTS		CALIBRATION	
AM	M1	CALIBRATE Off	C0
FM	M2	CALIBRATE On	C1
ΦM	M3	% CAL FACTOR	CF
RF POWER	M4	SET REF	RF
FREQ	M5	ZERO	ZR
AUDIO FREQ	S1	SAVE CAL	SC
AUDIO DISTN	S2	MANUAL OPERATIONS	
IF LEVEL	S3	AUTO TUNING	AT
TUNED RF LEVEL	S4	ENABLE ERRORS	B0
FREQ ERROR	S5	DISABLE ERRORS	B1
		CLEAR (KEY)	CL
DETECTORS		BLUE KEY, CLEAR (KEY)	BC
PEAK+	D1	DISPLAY FREQ	FR
PEAK-	D2	DISPLAY INCREMENT	FN
PEAK HOLD	D3	INPUT FREQUENCY (Hz)	HZ
AVG (RMS Calibrated)	D4	↑ Hz	HU
1 kHz DISTN	D5	↓ Hz	HD
400 Hz DISTN	D6	TRACK Mode Off (Lock Mode)	K0
RMS	D8	TRACK Mode On	K1
PEAK±/2	D9	↑ kHz	KU
		↓ kHz	KD
DISPLAYS		MHz (INPUT FREQ)	MZ
Display LOG Result	LG	RECALL	RC
Display LIN Result	LN	STORE	TR
dB EXT ATTEN off	N0	SPECIAL FUNCTION	SP
dB EXT ATTEN on	N1	SPECIAL, SPECIAL	SS
RATIO Off	R0	mV Units	MV
RATIO On	R1	μV Units	UV
PREVIOUS RATIO	R2	V Units	VL
		W Units	WT
FILTERS		MISCELLANEOUS	
HP (High-Pass) FILTERS Off	H0	MODULATION OUTPUT	A0
50 Hz FILTER On	H1	AUDIO INPUT	A1
300 Hz FILTER On	H2	AUTOMATIC OPERATION	AU
LP (Low-Pass) FILTERS Off	L0	Auto-Ranging (RANGE HOLD Off)	G0
3 kHz FILTER On	L1	RANGE HOLD	G1
15 kHz FILTER On	L2	Identify Instrument	ID
>20 kHz FILTER On	L3	INSTR PRESET (same as DCL)	IP
FM DE-EMPHASIS		Trigger Off	T0
PRE-DISPLAY Off and		Hold	T1
FM DE-EMPHASIS Off	P0	Trigger Immediate	T2
PRE-DISPLAY On and		Trigger with Settling	T3
FM DE-EMPHASIS On	P1	Hexidecimal A	X0
25 μs DE-EMPHASIS	P2	Hexidecimal B	X1
50 μs DE-EMPHASIS	P3	Hexidecimal C	X2
75 μs DE-EMPHASIS	P4	Hexidecimal D	X3
750 μs DE-EMPHASIS	P5	Hexidecimal E	X4
		Hexidecimal F	X5

Code to Measuring Receiver Function Summary

Code	Function	Code	Function
A0	MODULATION OUTPUT	M1	AM
A1	AUDIO INPUT	M2	FM
AT	AUTO TUNING	M3	ΦM
AU	AUTOMATIC OPERATION	M4	RF POWER
B0	ENABLE ERRORS	M5	FREQ
B1	DISABLE ERRORS	MV	mV Units
BC	BLUE KEY, CLEAR (KEY)	MZ	MHz (INPUT FREQ)
C0	CALIBRATE Off	N0	dB EXT ATTEN Off
C1	CALIBRATE On	N1	dB EXT ATTEN On
CF	% CAL FACTOR	P0	PRE-DISPLAY Off and FM DE-EMPHASIS Off
CL	CLEAR (KEY)	P1	PRE-DISPLAY On and DE-EMPHASIS On
D1	PEAK+	P2	25 μs DE-EMPHASIS
D2	PEAK-	P3	50 μs DE-EMPHASIS
D3	PEAK HOLD	P4	75 μs DE-EMPHASIS
D4	AVG (RMS Calibrated)	P5	750 μs DE-EMPHASIS
D5	1 kHz DISTN	R0	RATIO Off
D6	400 Hz DISTN	R1	RATIO On
D8	RMS	R2	PREVIOUS RATIO
D9	PEAK±/2	RC	RECALL
FR	DISPLAY FREQ	RF	SET REF
FN	DISPLAY INCREMENT	S1	AUDIO FREQ
G0	Auto-Ranging (RANGE HOLD Off)	S2	AUDIO DISTN
G1	RANGE HOLD	S3	IF LEVEL
H0	HP (High-Pass) FILTERS Off	S4	TUNED RF LEVEL
H1	50 Hz FILTER On	S5	FREQ ERROR
H2	300 Hz FILTER On	SC	SAVE CAL
HU	↑ Hz	SP	SPECIAL FUNCTION
HD	↓ Hz	SS	SPECIAL, SPECIAL
HZ	INPUT FREQUENCY (Hz)	T0	Trigger Off
ID	Identify Instrument	T1	Hold
IP	INSTR PRESET (same as DCL)	T2	Trigger Immediate
K0	TRACK Mode Off (lock mode)	T3	Trigger with Settling
K1	TRACK Mode On	TR	STORE
KU	↑ kHz	UV	μV Units
KD	↓ kHz	VL	V Units
L0	LP (Low-Pass) FILTERS Off	WT	W Units
L1	3 kHz FILTER On	X0	Hexidecimal A
L2	15 kHz FILTER On	X1	Hexidecimal B
L3	>20 kHz FILTER On	X2	Hexidecimal C
LG	Display LOG Result	X3	Hexidecimal D
LN	Display LIN Result	X4	Hexidecimal E
		X5	Hexidecimal F
		ZR	ZERO

HP 8901A/02A Code Differences

HP 8901A	HP 8902A	Functions
A1 (or AU)	AU	AUTOMATIC OPERATION
F1 (or MZ)	MZ	MHz (INPUT FREQ)
F2 (or KU)	KU	↑ kHz
F3 (or KD)	KD	↓ kHz
F4 (or Z4 or SP)	SP	SPECIAL
F5 (or Z5 or SS)	SS	SPECIAL, SPECIAL
K1 (or CL)	CL	CLEAR
U1 (or D1)	D1	PEAK+
U2 (or D2)	D2	PEAK-
U3 (or D3)	D3	PEAK HOLD
U4 (or D4)	D4	Average Detector (RMS Calibrated)
Z1 (or HZ)	HZ	Hz INPUT FREQ
Z2 (or HU)	HU	↑ Hz
Z3 (or HD)	HD	↓ Hz
M4	35.0SP	Peak RF Level
S4	36.0SP	Peak Tuned RF Level
R1	LN, R1	% RATIO
R2	LG, R1	dB RATIO
4.0SP	AT, K0	Auto Tuning, low-noise lock mode
4.1SP	AT, K1	Auto Tuning, track mode
4.2SP	MZ, K0	Manual Tuning, low-noise lock mode
7.1SP	7.1SP	10 Hz frequency resolution
7.2SP	7.3SP	1000 Hz frequency resolution
9.0SP	G1	Hold Setting (RANGE HOLD)
10.0SP	34.0SP	IF Frequency
11.0SP	LN, R2	% PREVIOUS RATIO
11.1SP	LG, R2	dB PREVIOUS RATIO
11.3SP	use "-" key	Make Ratio Reference Negative
15.0SP	15.0SP	Oven Check (returns "0" if oven OK or not installed, rather than doing nothing as in the 8901A)
Status Byte	Status Byte	Status Byte Bits "Upper Limit" (weight 8) and "Lower Limit" (weight 16) are merged together into "Limit Reached" (weight 8)



HP Part No. 08962-90060

Printed in U.S.A.