

8733B

HEWLETT-PACKARD

## OPERATING NOTE

MLTP  
REFERENCE  
FILE

## PIN MODULATORS

## 8730A/B SERIES

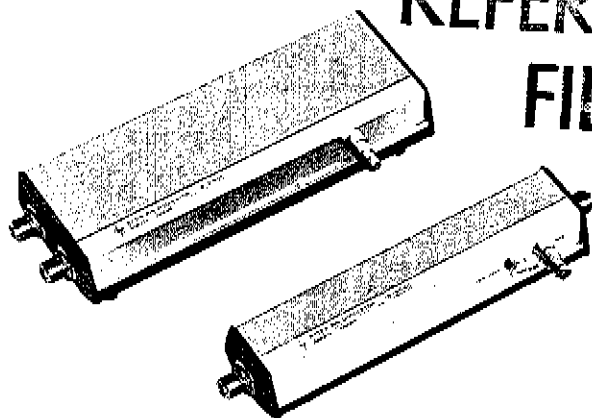
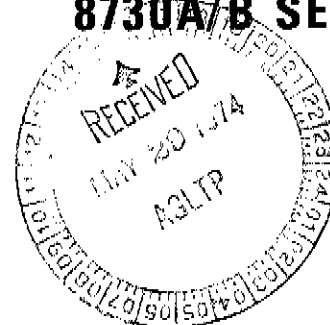

Figure 1. Typical Model 8730A/B Series  
PIN Modulators



## 1. INTRODUCTION.

2. The Hewlett-Packard 8730 series of PIN modulators (Figure 1) are variable RF attenuators whose input and output impedance is nearly constant for all levels of attenuation. The 8730 PIN Modulators cover the coaxial range from 0.8 to 12.4 GHz in four overlapping bands in addition to X-band in waveguide. Two models are available in each band: an "A" model which provides at least 35 dB of attenuation range, and a "B" model which provides at least 80 dB. Typical uses include pulsing, switching, leveling, and amplitude modulating of RF signals. Table 1 lists complete PIN Modulator specifications.

## 3. PRECAUTIONS.

4. MAXIMUM RF POWER. The maximum input rating (peak or CW) for the PIN Modulators is 1 watt. Excessive RF power levels will cause internal damage.

5. MAXIMUM BIAS INPUT. DC voltage applied to the BIAS input must not exceed +20 volts or -10 volts. Excessive DC voltages may cause internal damage.

## 6. STORAGE AND SHIPMENT.

7. ENVIRONMENT. Temperature during storage or shipment should be limited as follows:

- a. Maximum temperature: 149°F (+65°C).
- b. Minimum temperature: -40°F (-40°C).
- c. Humidity Maximum: 95%.

8. PACKAGING. To protect the 8730 PIN Modulators during storage or shipment, always use the best packaging methods available. The following suggested steps can be used as a guide for packaging.

- a. The original carton, if undamaged, can be reused.
- b. If the original carton is not usable, a double-walled carton (200 lb/sq inch bursting test) should be used.
- c. Wrap instrument in heavy protective paper to avoid abrasion.
- d. Place in carton, surrounded by at least four inches of tightly packed shock absorbing material.
- e. Seal carton with strong tape or metal bands.

HEWLETT  PACKARD

FOR REFERENCE PURPOSES ONLY

8730A/B

## **COPYRIGHT AND DISCLAIMER NOTICE**

Copyright – Agilent Technologies, Inc. Reproduced with the permission of Agilent Technologies Inc. Agilent Technologies, Inc. makes no warranty of any kind with regard to this material including, but not limited to, the implied warranties of merchantability and fitness for a particular purpose. Agilent Technologies, Inc. is not liable for errors contained herein or for incidental or consequential damages in connection with the furnishing, performance, or use of this material or data.





# MANUAL CHANGES

MODEL 8730A/B SERIES  
PIN MODULATORS

Printed: April 1969

MAKE ALL CORRECTIONS IN THIS MANUAL ACCORDING TO ERRATA BELOW, THEN CHECK THE FOLLOWING TABLE FOR YOUR INSTRUMENT SERIAL PREFIX (3 DIGITS) OR SERIAL NUMBER (8 DIGITS) AND MAKE ANY LISTED CHANGE(S) IN THE MANUAL.

► NEW ITEM.

SERIAL PREFIX OR NUMBER	MAKE MANUAL CHANGES	SERIAL PREFIX OR NUMBER	MAKE MANUAL CHANGES

**ERRATA:**

Page 3, Paragraph 14:

Delete last sentence, and replace with the following:

"However, when the diodes are reverse- or back-biased the equivalent diode resistance is in the order of thousands of ohms and the microwave currents will flow down the transmission path because the 50-ohm path impedance compared to the diode resistance is negligible."

► Page 11, Paragraph 42:

Delete first part of Paragraph 42 and replace with the following:

The PIN modulator CANNOT be repaired in the field. If the PIN modulator is found to be faulty, it should be returned to the factory through your local field office (see inside back cover). Remove . . .

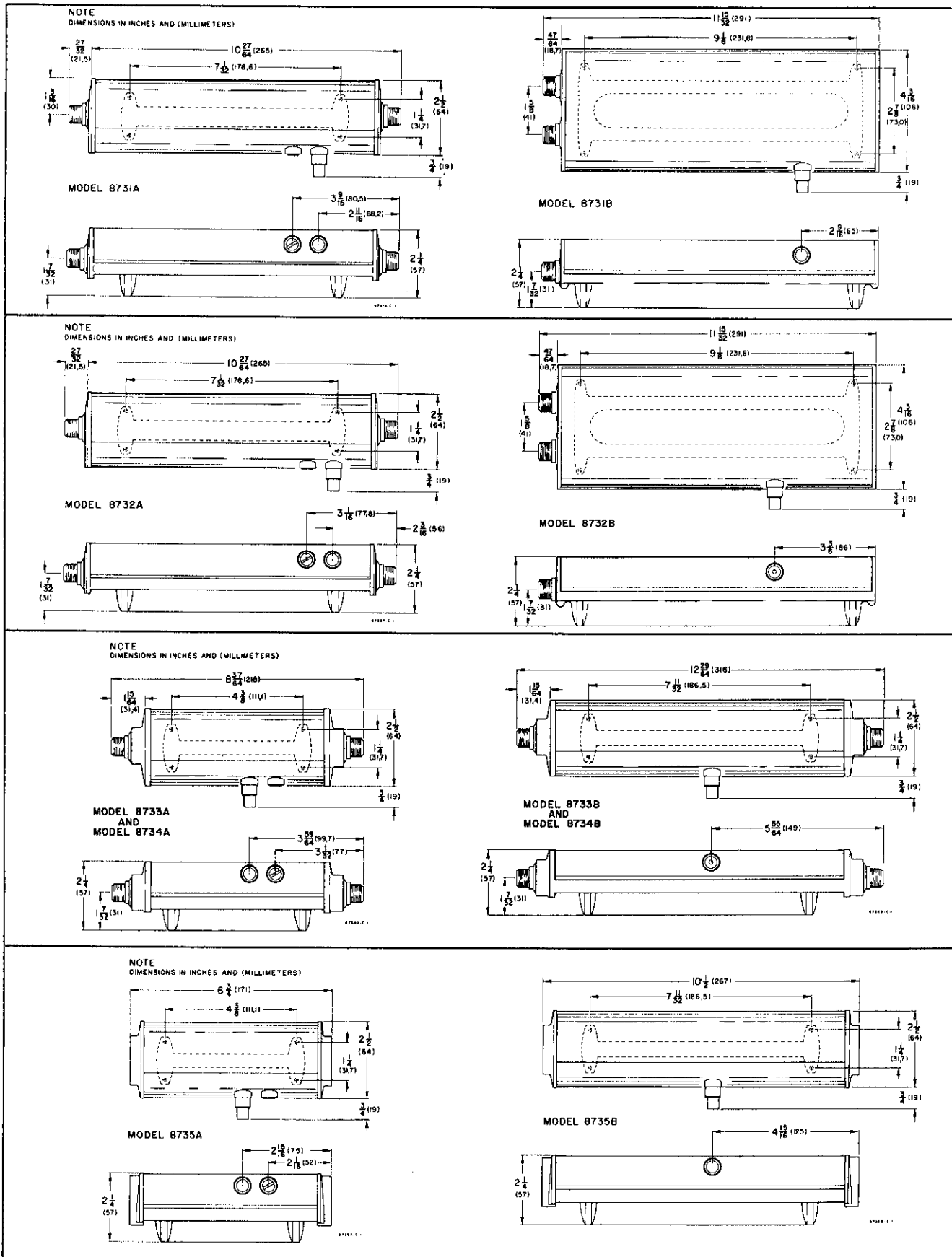

Figure 2. General Outside Dimensions

Table 1. Specifications

	8731A	8731B	8732A	8732B	8733A	8733B	8734A	8734B	8735A	8735B
Frequency Range (GHz)	0.8-2.4	0.8-2.4	1.8-4.5	1.8-4.5	3.7-8.3	3.7-8.3	7.0-12.4	7.0-12.4	8.2-12.4	8.2-12.4
Dynamic Range (dB)	35	80	35	80	35	80	35	80	35	80
Min. Insertion Loss (dB) <sup>1</sup>	< 1.5	< 2.0	< 2.0	< 3.5 <sup>2</sup>	2.0	< 3.0	< 4.0	< 5.0	< 4.0	< 5.0
Typical Rise Time (nsec) <sup>3</sup>	40	30	40	30	30	30	30	30	30	30
Typical Decay Time (nsec) <sup>3</sup>	30	20	30	20	20	20	20	20	20	20
SWR, Minimum Attenuation	1.5	1.6	1.5	1.6 <sup>4</sup>	1.8	2.0	1.8	2.0	1.7	1.9
SWR, Maximum Attenuation	1.8	2.0	1.8 <sup>9</sup>	2.0	2.0	2.2	2.0	2.2	2.0	2.2
Maximum Input Power, Peak or CW (watts)	1	1	1	1	1	1	1	1	1	1
Bias Limits (volts) <sup>5</sup>	+20, -10	+20, -10	+20, -10	+20, -10	+20, -10	+20, -10	+20, -10	+20, -10	+20, -10	+20, -10
Typical Forward Bias Input Resistance (ohms) <sup>6</sup>	300	100	300	100	300	100	300	100	300	100
RF Connector Type	N <sup>8</sup>	N <sup>8</sup>	N <sup>8</sup>	N <sup>8</sup>	N <sup>8</sup>	N <sup>8</sup>	N <sup>8</sup>	N <sup>8</sup>	W/G <sup>7</sup>	W/G <sup>7</sup>
Weight (lbs)	2-3/4	5-1/2	2-3/4	5-1/2	2	3	2	3	2	3
(kg)	1,2	2,5	1,2	2,5	0,9	1,4	0,9	1,4	0,9	1,4
Dimensions	Illustrated in Figure 2									

- 1. +5 bias
- 2. 4.0, 4.0 to 4.5 GHz
- 3. Driven by HP 8403A Modulator
- 4. 2.0, 4.0 to 4.5 GHz
- 5. Negative voltage applies forward bias to diodes
- 6. At attenuation levels of 10 dB or more
- 7. Fits 1 x 1/2 in. (WR 90) waveguide
- 8. Standard female type N
- 9. 1.8, 1.8 to 4.0 GHz; 2.0, 4.0 to 4.5 GHz.

**9. PERMANENT MOUNTING.**

10. Four 6-32 tapped mounting holes have been provided for mounting purposes. The location of these holes and the overall external dimensions of the PIN Modulators are illustrated in Figure 2.

**CAUTION**

Also on the PIN Modulator underside are the four cover retaining screws and the PIN diode retaining screws. Any movement or adjustment of diode retaining screws will cause permanent damage.

**11. PRINCIPLES OF OPERATION.**

12. The PIN Modulator is a high-speed, current-controlled absorption type attenuator. A simplified illustration of the modulator is shown in Figure 3. Each PIN unit includes a low-pass filter, two high-pass filters, a number of PIN diodes, and a 50-ohm strip transmission line (ridged waveguide in the higher frequency Model 8733, 8734, and 8735 units).

13. The PIN diode is a silicon junction diode whose P and N trace regions are separated by a layer of intrinsic (I) semiconductor (silicon). Thus the name PIN diode. At frequencies below about 100 MHz the PIN diode rectifies as a junction diode. However, at frequencies above 100 MHz, rectification ceases due to stored charge in the intrinsic (I) layer and the diode acts like a resistance by conducting current in both directions. This equivalent resistance is inversely proportional to the amount of charge in the I layer. An increase in forward bias current (current at a negative voltage) increases the stored charge and decreases the equivalent resistance of the PIN diodes. When reverse bias is applied, reverse current flows until stored charge is depleted at which time equivalent resistance becomes a maximum in the order of thousands of ohms.

14. PIN DIODES IN SHUNT. To understand how a PIN Modulator works, consider the following: the PIN diodes are mounted as shunt elements between the RF transmission path and ground. The transmission path has a characteristic impedance of 50 ohms. When the PIN diodes are forward-biased the equivalent diode resistance is about 30 ohms and most of the RF energy is absorbed by the diodes instead of propagating down the 50-ohm transmission path. However, when the diodes are reverse- or back-biased the equivalent diode resistance is in the order of thousands of ohms and the microwave currents will flow down the transmission path because diode resistance compared to the 50-ohm path impedance is negligible.

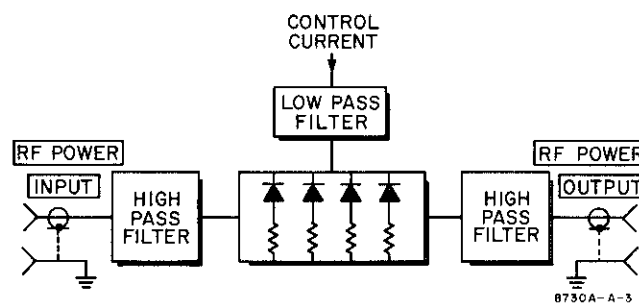

Figure 3. Simplified Block Diagram of PIN Modulator

**15. BIASING.**

16. Each individual PIN Modulator has a label attached to the underside of its casting body. This label has a DC bias current value stamped onto it. This stamped current is the forward-bias current required to produce rated RF attenuation across the frequency band. For "A" models, the bias current for at least 35 dB is typically 3-1/2 to 5 milliamperes (about -0.7 volts DC at the BIAS input). For "B" models, the bias current

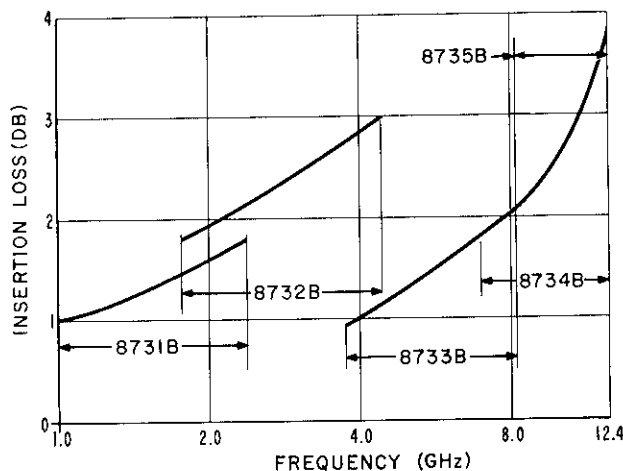
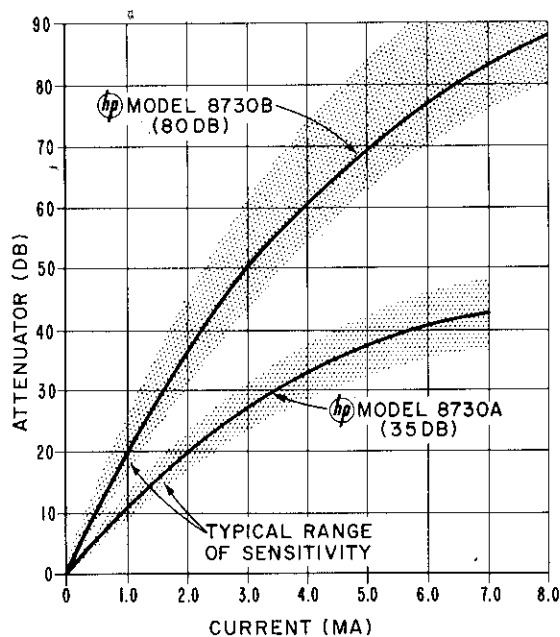

Figure 4. Typical Insertion Loss Curves

for at least 80 dB is typically 6 to 7 milliamperes (about -0.7 volts DC at the BIAS input). For applications where a minimum insertion loss is important, a back-bias of about +5 to 7 volts DC should be applied to the BIAS input. Back-biasing can result in as much as a 1 dB improvement in insertion loss over zero bias. A typical plot of the maximum values of minimum insertion loss is shown in Figure 4. Note: A typical plot for the "A" models would be the same except that maximum losses are less.

Figure 5. Typical Sensitivity  
(Plotted with frequency constant)

17. The attenuation increases with forward bias current almost linearly in dB until diode saturation occurs. The attenuation sensitivity varies from unit to unit but the sensitivity of a given unit is predictable. Therefore, intermediate values of attenuation can be derived once the current values for a low and high at-

tenuation are established. The range of expected sensitivities is shown as the shaded areas in the plots of typical 35-dB and 80-dB attenuation characteristics in Figure 5.

18. The attenuation with a constant forward-bias varies with frequency. This variation is small at low levels of attenuation and more noticeable at higher values of attenuation (see Figure 6). In addition, it should be noted that attenuation is a minimum at each end of the frequency band. Thus, the frequency band can be exceeded provided a degradation in attenuation range as well as other specifications is acceptable. Note: exceeding the band limits by a large degree is unpractical.

#### 19. IMPEDANCE MATCH.

20. The PIN Modulator has a good impedance match at all levels of attenuation over its frequency range. This match is illustrated in Figure 7 which shows the SWR of a typical PIN Modulator measured under both zero bias and maximum forward bias conditions. Hence, with this constant match, frequency pulling effects due to the PIN Modulator is negligible. If the PIN Modulator is used outside specified frequency range, SWR characteristics will be degraded in addition to other operating specifications. However, spurious responses can result when exceeding specified frequency range. Note: exceeding band limits by a large degree is not generally practical.

#### 21. TEMPERATURE STABILITY.

22. The attenuation variation with applied bias current and bias voltage at different temperatures is illustrated, over a limited range, in Figure 8. Attenuation in DB varies almost linearly with current, while variation with voltage follows an almost perfect exponential curve. If a constant voltage is maintained, the attenuation rises with increasing temperature. With a constant current, the attenuation drops with increasing temperature. The fact that the attenuation varies oppositely with temperature for constant-voltage and constant-current operation suggests that an optimum voltage with a selected series resistor added between the source and the PIN Modulator would give temperature compensation over a limited operating range. This compensation is not built into the PIN Modulator.

#### 23. GENERAL OPERATION.

24. The PIN Modulators are three-port devices which accept RF power at either end-port and depending upon the BIAS signal applied, provide a modulated RF output at the other end-port. As an operating device, the PIN Modulator should be thought of as a variable RF attenuator whose attenuation level is controlled by DC current and voltage. By applying a +5 volt DC potential to the BIAS input connector, RF signals will be passed through the PIN Modulator with only minimum insertion loss. By applying a current equal to the value stamped on the instrument label (at about 0.7

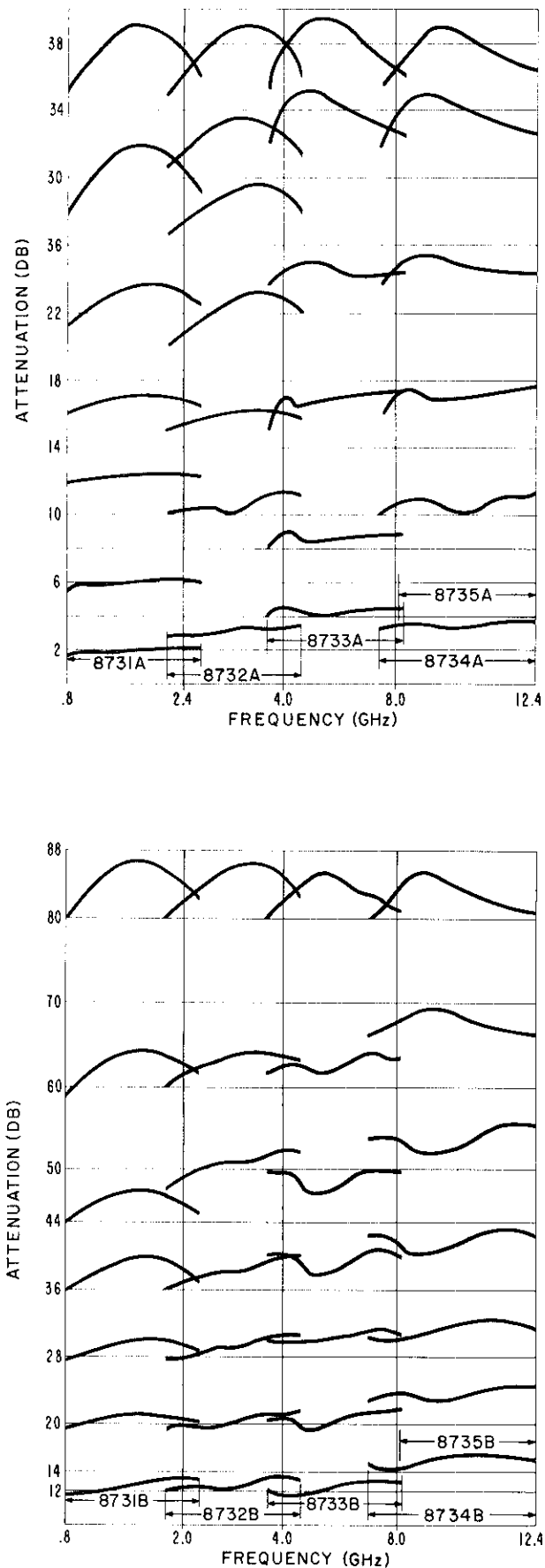

Figure 6. Typical Frequency Response

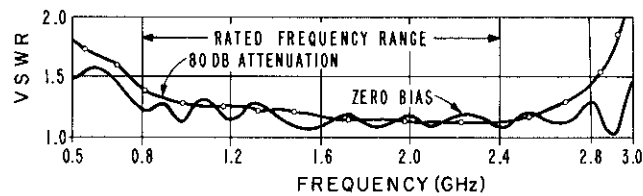

Figure 7. Typical SWR of a PIN Modulator (8732B)

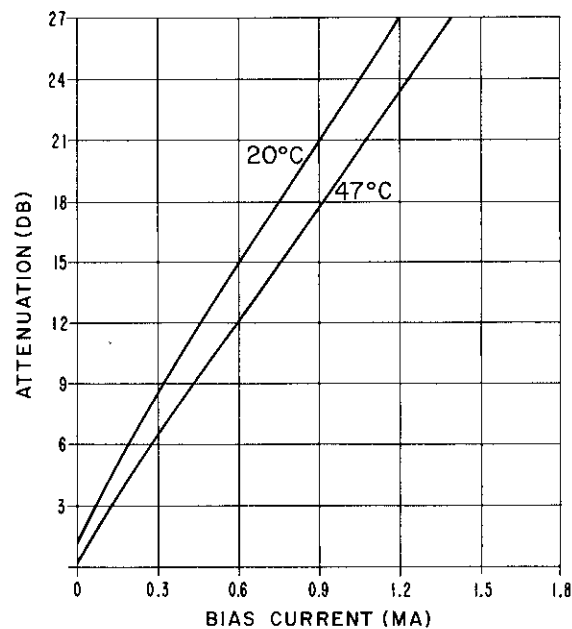
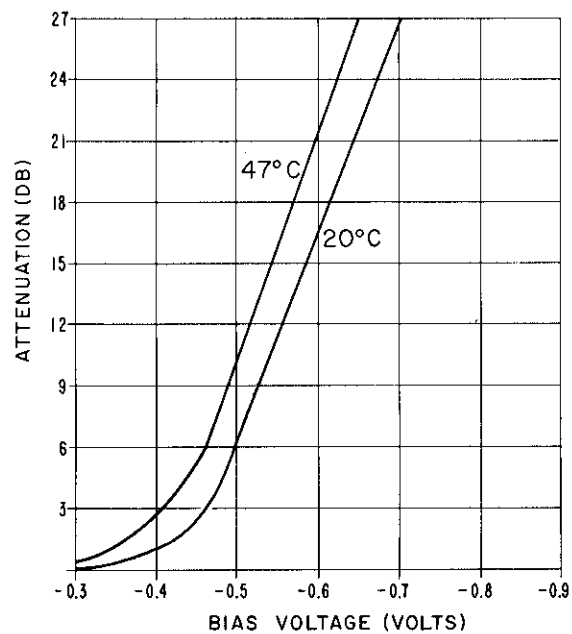

Figure 8. Typical Attenuation Variation at two Different Ambient Temperatures

volts DC) at the BIAS input, at least rated attenuation is provided at all points across the frequency band (i. e., for "A" models at least 35 dB and for "B" models at least 80 dB). The DC current at a negative voltage is forward-bias and typically is about 3 to 5 mA for "A" models and 6 to 7 mA for "B" models. By varying the forward bias current between the stamped value and zero, any level below maximum rated attenuation can be established.

## 25. CLOSED LOOP LEVELING.

26. The PIN Modulator can be used in a closed loop leveling system as the power limiting device for maintaining RF power levels constant. A simplified block diagram of a closed loop leveling system employing a PIN modulator is shown in Figure 9. The system consists of some sampling device which samples the main line RF power level; a detecting device provides a DC signal proportional to the sampled signal; some comparison device which compares the detected signal to what it should be when main line power is at its lowest point and then provides a bias current sufficient to increase PIN Modulator attenuation and maintain a constant RF power level.

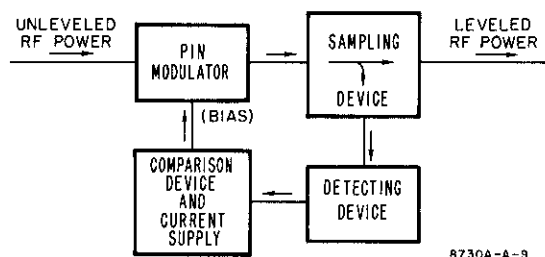

Figure 9. Simplified Block Diagram of a Closed Loop Leveling System

27. LEVELING CAPABILITY. In a closed-loop leveling system involving a PIN Modulator, leveling capability depends entirely upon loop equipment. Hence, loop equipment should be selected on the basis of main line RF power levels and leveling requirements. In the closed-loop system shown in Figure 10 the flatness of leveling is determined primarily by the coupling variation of the directional coupler used. The Power Meter is used because it provides extra loop gain. In addition, with output coupling known, the main line output power can be read directly on the Power Meter allowing for coupling variation. The Leveler Amplifier used has a 0 to -27 Vdc output capability with output impedance of about 20K ohms, hence the 20K ohms series resistor makes it a bias current source providing a maximum 1.35 mA DC current (referring to Figure 5, this means that the maximum control range possible using an "A" model 8730 is between 12 and 20 dB depending upon the individual 8730 used). Typically, with the Power Meter and Leveler Amplifier combination, leveled power can be held constant with  $\pm 0.2$  dB (plus coupler variation) for RF swept frequency rates equal to or longer than 30 seconds/octave. In practice, slowest swept frequency

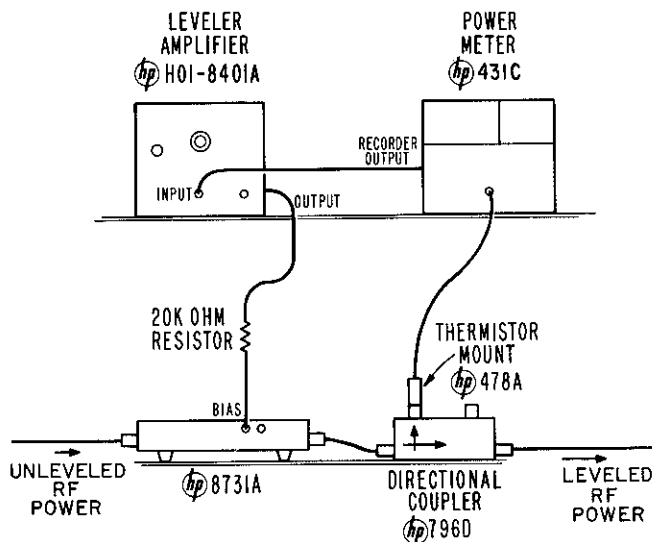

Figure 10. Typical Closed Loop Leveling System

rates always produce the best leveling. However, to determine whether or not any system is leveling properly an Oscilloscope should be used.

28. For faster leveled swept frequency rates, negative output detector and directional coupler combinations such as the hp Model 786D and 787D Directional Detectors can be used instead of the Power Meter and Thermistor Mount combination described above. Typically, for the Directional Detector and Leveler Amplifier combination, leveled power can be held constant with  $\pm 0.2$  dB (plus frequency response of Directional Detector). Note: the frequency response of the Directional Detector includes coupling variation and RF response of the crystal. For the Model 786D (0.96 to 2.11 GHz) this is  $\pm 0.2$  dB.

## 29. AMPLITUDE MODULATION.

30. The PIN Modulator can be used to amplitude-modulate the RF signal with almost any time-varying signal. Modulation is accomplished with a DC bias current to obtain a specific attenuation level and then superimposing a time varying current upon the bias current. The specific attenuation level upon which the modulating signal is superimposed must be equal to or greater than the peak amplitude of the modulating signal or peak clipping will occur. A control instrument designed for use in modulating applications with the PIN Modulators is the hp Model 8403A Modulator which provides frequency compensation for extending the PIN Modulator AM frequency response to 10 MHz. However, a typical setup for modulating applications, without the use of the hp Model 8403A Modulator, is illustrated in Figure 11.

31. MODULATION DISTORTION. When a PIN Modulator is used in an AM system, some envelope distortion occurs. This distortion is a function of the peak attenuation and total attenuation range covered by the modulating signal. To minimize RF envelope distortion, the reference level upon which the modu-



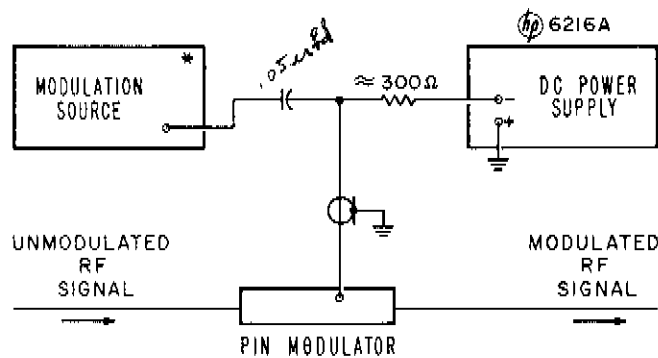

\* FOR PULSE MODULATION: MODEL 211A, 212A, 214A, 215A  
 FOR AMPLITUDE MODULATION: MODEL 208A, 651A

Figure 11. Typical General Modulation Setup

lating signal is superimposed should always be a minimum (i.e., reference level should be set at a point only slightly greater than the peak modulating signal amplitude). Under these conditions, a 50% sinusoidal modulating signal (9.5 dB total swing) will result in less than 6.1% distortion. A plot of measured AM distortion for a typical PIN Modulator is shown in Figure 12. Note: AM distortion was measured under the optimum conditions described above. Since distortion, as described here, is a function of the non-linear sensitivity relationship (shown in Figure 5), shaping circuits may be incorporated to limit overall distortion. Such a shaping circuit is shown in Figure 13.

32. AMPLITUDE MODULATION LIMITATION. In any AM system the modulating equipment limits RF modulating capabilities almost entirely. For example, the power supply and modulation signal source must both be capable of supplying sufficient current to the low impedance 8730 BIAS input. See Figure 5 for typical currents necessary for desired attenuation levels. In addition, the PIN Modulator itself limits the total percent of modulation obtainable. With 35 dB attenuation, AM percent of modulation is limited to a maximum of about 96.5%; with 80 dB attenuation the percent of modulation is for all practical purposes 100%.

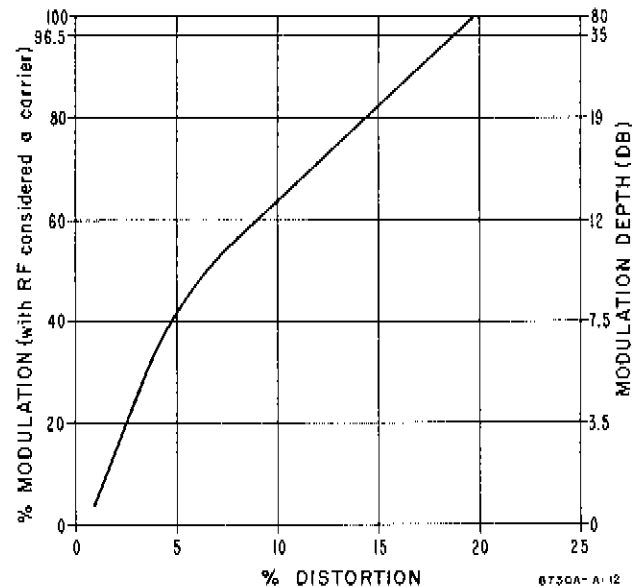
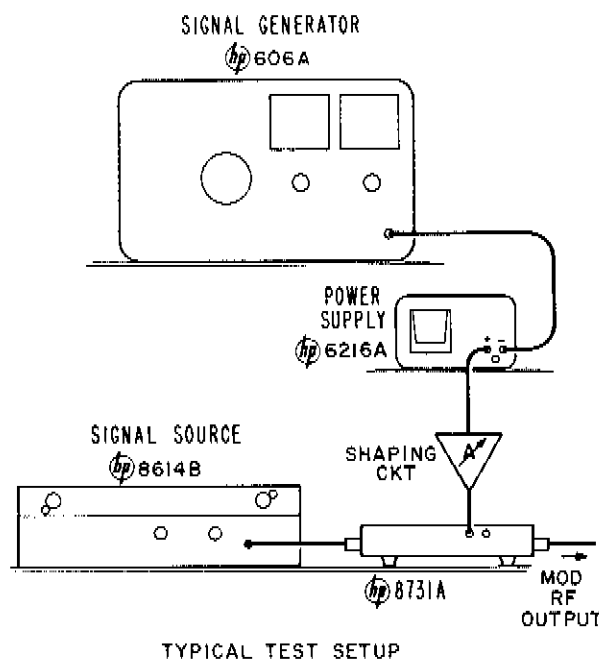

Figure 12. Typical AM Distortion



TYPICAL TEST SETUP

INPUT VOLTAGE	TEST POINT VOLTAGES (DC)					
	1	2	3	4	5	6
10VDC	-3.30	-3.63 -4.36	-3.8 -4.5	-4.8 -5.5	-6.5 -7.0	
5.4VDC	-3.59	-3.75 -4.41	-3.98 -4.6	-4.9 -5.6	-6.5 -7.0	
3.0VDC	-3.92	-4.04 -4.42	-4.2 -4.6	-5.0 -5.6	-6.6 -7.0	
1.65VDC	-4.28	-4.38 -4.43	-4.5 -4.6	-5.3 -5.6	-6.7 -7.0	
0.85VDC	-4.63	-4.72 -4.44	-4.9 -4.6	-5.5 -5.6	-6.9 -7.0	-2.7 -3.1
0.5VDC						-2.7 -3.3
⊥	-4.94	-5.03 -4.45	-5.18 -4.51	-5.8 -5.5	-7.2 -6.9	-2.7 -3.5

Figure 13A. Typical Test Setup (see Figure 13B)

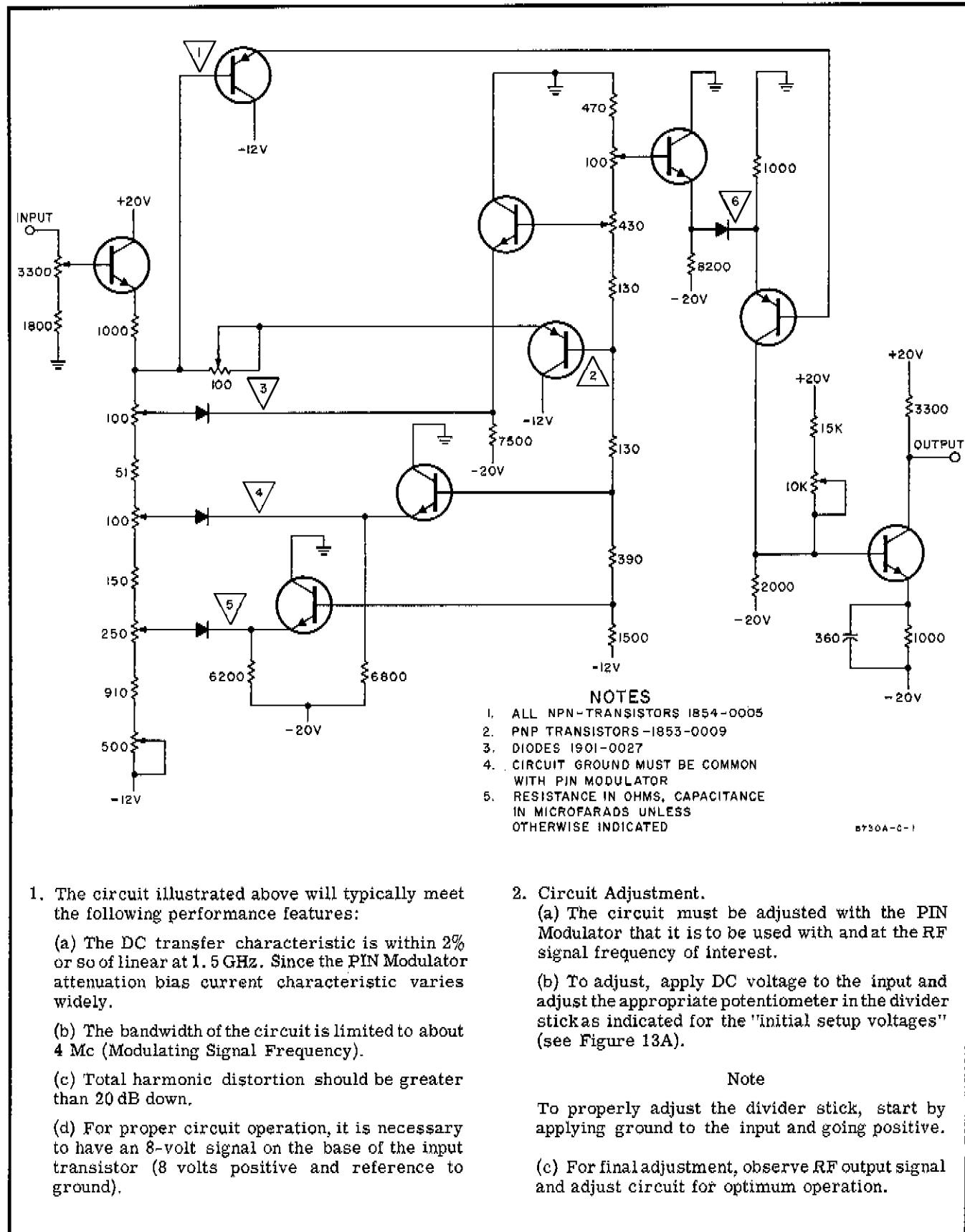

1. The circuit illustrated above will typically meet the following performance features:

(a) The DC transfer characteristic is within 2% or so of linear at 1.5 GHz. Since the PIN Modulator attenuation bias current characteristic varies widely.

(b) The bandwidth of the circuit is limited to about 4 Mc (Modulating Signal Frequency).

(c) Total harmonic distortion should be greater than 20 dB down.

(d) For proper circuit operation, it is necessary to have an 8-volt signal on the base of the input transistor (8 volts positive and reference to ground).

2. Circuit Adjustment.

(a) The circuit must be adjusted with the PIN Modulator that it is to be used with and at the RF signal frequency of interest.

(b) To adjust, apply DC voltage to the input and adjust the appropriate potentiometer in the divider stick as indicated for the "initial setup voltages" (see Figure 13A).

Figure 13B. Typical Shaping Circuit

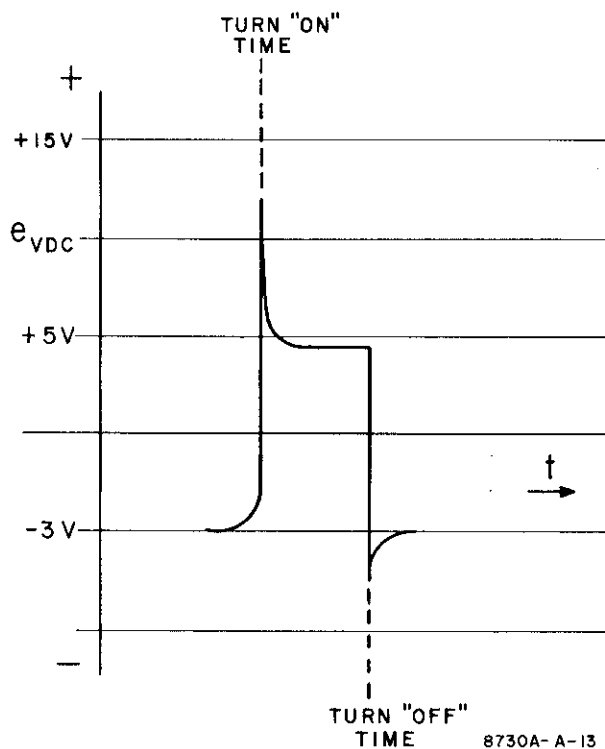

Figure 14. Dynamic Bias Switching Waveform

**33. PULSE MODULATION.**

34. The PIN Modulator can be used as a pulsing or switching device for RF power levels. Modulation is accomplished by applying rated forward bias (see label attached to underside of PIN Modulator) for a maximum attenuation. Once maximum attenuation level is established, the RF power may be pulsed "on" by applying a constant +5 to 6 volts to the BIAS input (voltage must be referenced to PIN Modulator ground).

At the end of desired pulse width, the +5 to 6 volt DC potential must be switched to a -0.8 volt level with rated bias current so that RF power level is pulsed "off".

35. To obtain pulsing with rise and fall times in the order of 15 to 40 nanoseconds, the PIN Modulator must be biased with the HP Model 8403A or from a specially shaped impulse waveform such as is illustrated in Figure 14. However, if rise and fall times in the order of 100 to 300 nanoseconds are satisfactory, a setup such as is shown in Figure 11 may be used. Note: in any modulating system, modulating capability depends upon the modulating waveform at the BIAS input connector. Hence, lead lengths should be as short as possible to avoid capacitive cable effects.

**36. SIGNAL SEPARATION (GATING).**

37. Figures 15 and 16, respectively, illustrate use of the PIN Modulator as an RF gating device for eliminating spurious or "ghost" signals in antenna range receivers (Figure 15) or multiple signal separation in a spectrum analysis system (Figure 16).

**38. MULTIPLE FUNCTION.**

39. For certain applications, it may be desirable to level and amplitude modulate a given RF power level with the same PIN Modulator. This can be accomplished by simply setting up a closed loop leveling system and adjusting the reference attenuation level to a point equal to the peak amplitude of the desired modulating signal. For this type of dual application the modulating signal can be applied directly to the leveler amplifier in the system shown in Figure 10.

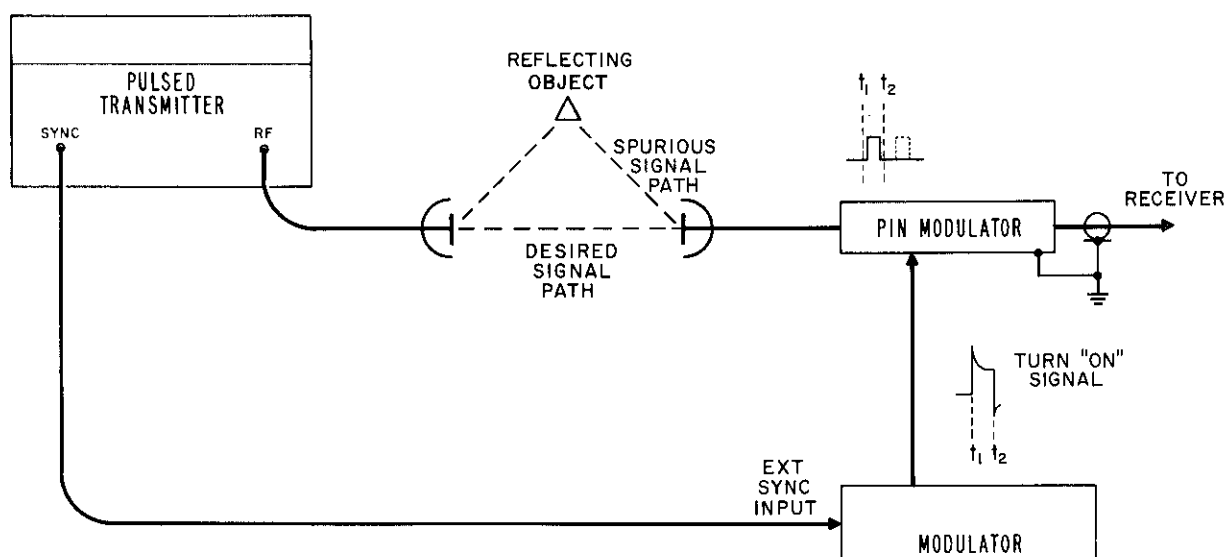
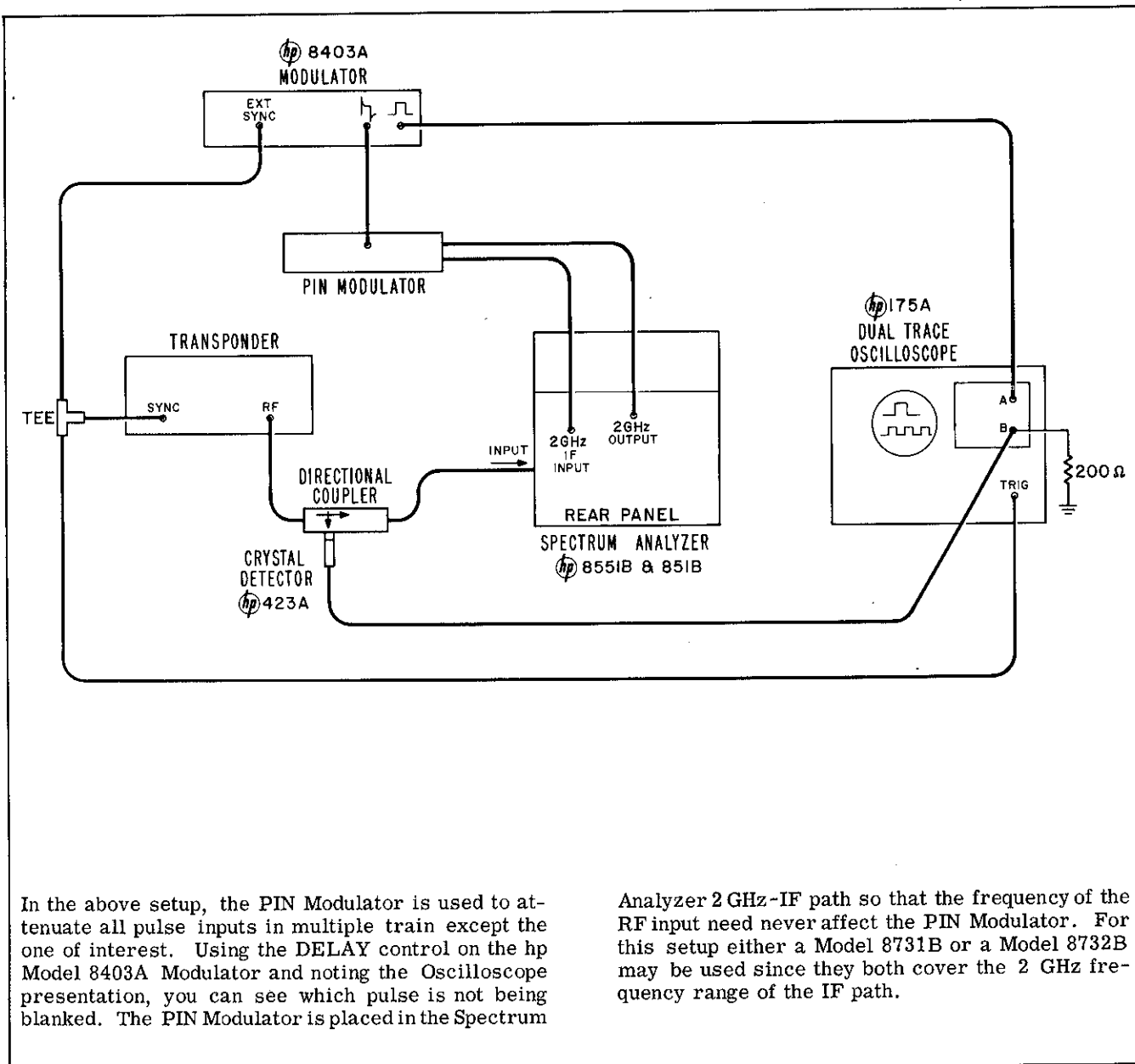

Figure 15. Typical Use of PIN Modulator as an RF Gating Device



In the above setup, the PIN Modulator is used to attenuate all pulse inputs in multiple train except the one of interest. Using the DELAY control on the hp Model 8403A Modulator and noting the Oscilloscope presentation, you can see which pulse is not being blanked. The PIN Modulator is placed in the Spectrum

Analyzer 2 GHz-IF path so that the frequency of the RF input need never affect the PIN Modulator. For this setup either a Model 8731B or a Model 8732B may be used since they both cover the 2 GHz frequency range of the IF path.

Figure 16. Multiple Signal Separation for Spectrum Analysis

**40. MAINTENANCE.**

**41. PIN MODULATOR REMOVAL AND REPLACEMENT.**

42. The PIN modulator CANNOT be repaired in the field. If the PIN modulator is found to be faulty, it should be returned to the factory. Remove the four screws holding the PIN modulator only. Removal of screws holding the PIN diodes in place can cause contamination of PIN diodes, high SWR, etc.

- a. Remove power line from instrument.
- b. Remove top and bottom covers.
- c. Place instrument on its side (preferably the PIN modulator side).
- d. Remove retainer rings at RF POWER INPUT and OUTPUT connectors.
- e. Disconnect coaxial cable from PIN modulator at J105.
- f. Remove four screws holding PIN modulator to instrument chassis (located on top side of instrument).
- g. Remove PIN modulator from instrument.
- h. Carefully pack PIN modulator in a container and contact local HP field office.
- i. To replace PIN modulator, reverse the above procedure.

**43. BIAS INPUT CHECK AND REPAIR.**

44. If any part of the bias input assembly (Figure 19) is damaged, it can be replaced separately. However, it is good practice to replace the entire assembly. To check bias input assembly, remove the PIN Modulator and measure its resistance with an ohmmeter:

straight through the filter resistance should be less than 5 ohms; resistance between BNC center conductor and shell should be infinite.

**45. PERFORMANCE CHECK.**

46. PURPOSE. The procedure detailed in Table 2 checks PIN Modulator performance for incoming inspection, periodic evaluation, and troubleshooting. The tests are performed without access to the PIN Modulator interior, there is no need to remove PIN MODULATOR for performance checks. The specifications of Table 1 are the performance standards.

**47. CHECKING DESICCANT.**

48. Inspect desiccant regularly (Figure 17) and, if it is pink or red in color, either remove and dry it or replace it.

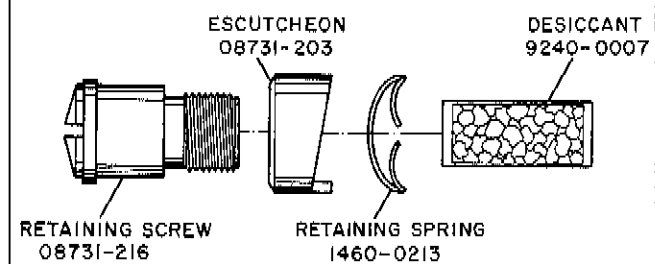

Figure 17. Desiccant Assembly

NOTE: Desiccant only found on 8731-5B; 815-models.

49. TEST EQUIPMENT REQUIRED. The test equipment required to make the performance tests are listed in Table 3. Instruments and accessories other than the ones listed may be used provided their performance equals or exceeds the Critical Specifications.

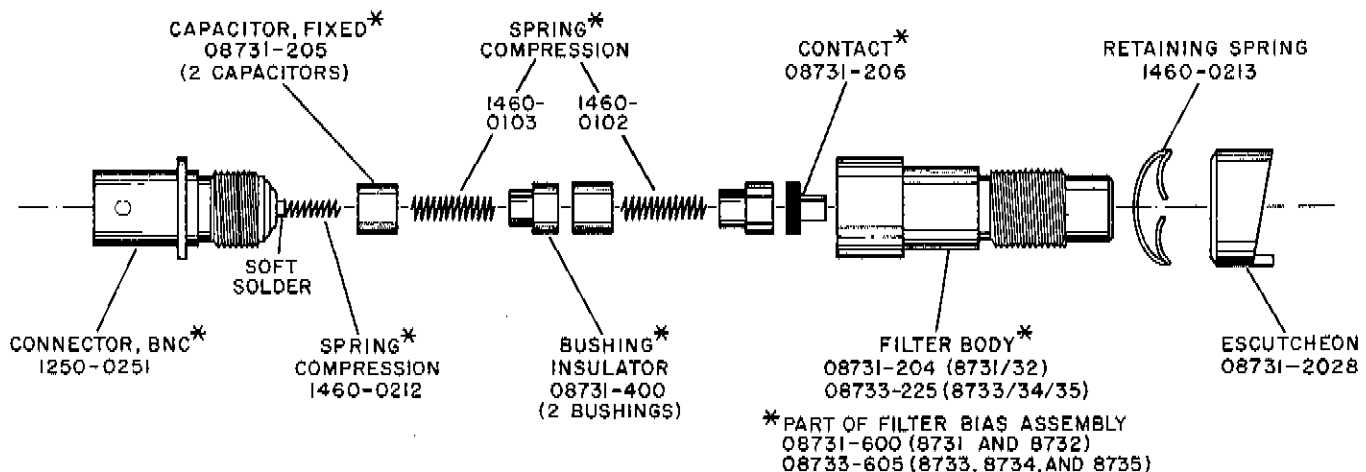

Figure 18. Bias Input Assembly

\*PART OF FILTER BIAS ASSEMBLY  
08731-600 (8731 AND 8732)  
08733-605 (8733, 8734, AND 8735)

Table 2. Performance Check Procedure

1. LEAKAGE CURRENT. When back-biased less than 50 $\mu$ A for "A" models and less than 100 $\mu$ A for "B" models (see Note 4).	
<b>PROCEDURE</b> a. Apply +20 volts DC (referenced to PIN Modulator ground) to the BIAS input through a 100K 10% 1/4 W resistor. b. Using a DC voltmeter, measure voltage across resistor. For "A" models less than 5 V (less than 10 V for "B" models). c. If leakage current is excessive, the cause is either a defective BIAS input filter (see Paragraph 43) or internal damage.	<b>TEST RESULTS (see Note 1)</b> Date _____ PIN Mod Serial No. _____ Measured DC Voltage _____ Voltmeter used _____
COMMENTS (if any) _____ _____	
2. DYNAMIC RANGE (DB). For "A" models (ONLY) at 35 dB across frequency range	
<b>PROCEDURE</b> a. With a 5 V DC applied to BIAS input, attach a 30-dB attenuator to PIN Modulator RF output. b. Using a Power Meter, adjust RF power source for a near full scale reference. c. Turn off Power Supply and reconnect to PIN Modulator as shown on next page. Adjust Power Supply for rated current (stamped on label attached to underside of PIN Modulator). d. Remove 30-dB attenuator and measure attenuated RF power level: it should be at least 5 dB lower than original reference setting.	<b>TEST RESULTS (see Note 1)</b> Date _____ PIN Mod Serial No. _____ Attenuation _____ frequency _____ Power Meter used _____ Measure forward bias current _____
COMMENTS (if any) _____ _____	
3. DYNAMIC RANGE (DB). For "B" models (ONLY) at least 80 dB.	
<b>PROCEDURE</b> a. Set Spectrum Analyzer INPUT ATTENUATOR to 60dB and connect test equipment (NOT INCLUDING THE DC POWER SUPPLY OR DC AMMETER) as shown beneath step c. <p style="text-align: center;"><b>CAUTION</b></p> For testing the 8733B, 8734B, or 8735B a TWT Amplifier must be used as part of the RF Source. Be careful not to apply more than 1 W of RF power to PIN Modulator. b. Apply +5 V DC (referenced in PIN Modulator ground) to BIAS input.	<b>TEST RESULTS (see Note 1)</b> Date _____ PIN Mod Serial No. _____ Attenuation _____ frequency _____ Attenuator used _____ Measured forward bias current _____

Table 2. Performance Check Procedure (cont'd)

c. Set Spectrum Analyzer vertical display switch for logarithmic display. Adjust RF Source and Spectrum Analyzer for a convenient deflection reference on analyzer display.

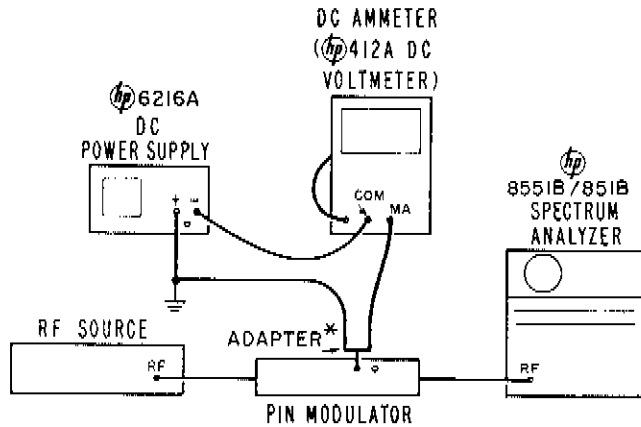

\*BNC-TO-BANANA POST ADAPTER 10110A

d. Turn off DC Power Supply and connect with DC Ammeter as shown below.

e. Turn on DC Power Supply and adjust for rated current (stamped on underside of PIN Modulator).

f. Decrease Spectrum Analyzer INPUT ATTENUATOR and increase IF GAIN controls for a total increase in sensitivity of 80 dB (i. e., decreasing the INPUT ATTENUATOR from 60 to 30 dB and increasing the IF GAIN control from 20 to 70 dB is a total increase in sensitivity of 80 dB). Specification: input signal deflection must be less than reference of step c.

**CAUTION**

If 1 watt of RF power is being applied, the Spectrum Analyzer ATTENUATOR must set to 60 dB in step c.

COMMENTS (if any) \_\_\_\_\_  
 \_\_\_\_\_

4. SWR. When back-biased less than

1.5:1 - 8731A & 8732A	1.8:1 - 8733A & 8734A
1.6:1 - 8731B	2.0:1 - 8733B & 8734B
1.6:1 - 8732B (see Note 2)	1.7:1 - 8735A
2.0:1	1.9:1 - 8735B

**PROCEDURE**

a. With a +5 volt DC (referenced to PIN Modulator ground) applied to BIAS input measure SWR at each end of the specified PIN Modulator frequency range and optionally at any other points of interest.

b. If SWR is excessive, remove PIN Modulator from setup and clean RF end-ports of any dirt or other foreign matter. Repeat SWR measurements.

**TEST RESULTS (see Note 1)**

Date \_\_\_\_\_

PIN Mod Serial No. \_\_\_\_\_

SWR \_\_\_\_\_ at a frequency of \_\_\_\_\_

Table 2. Performance Check Procedure (cont'd)

COMMENTS (if any) _____ _____							
<p>5. SWR. When forward-biased less than</p> <table style="width: 100%; border: none;"> <tr> <td style="width: 50%;">1.8:1 - 8731A &amp; 8732A</td> <td style="width: 50%;">2.0:1 - 8735A</td> </tr> <tr> <td>2.0:1 - 8731B &amp; 8732B</td> <td>2.2:1 - 8733B &amp; 8734B</td> </tr> <tr> <td>2.0:1 - 8733A &amp; 8734A</td> <td>2.2:1 - 8735B</td> </tr> </table>		1.8:1 - 8731A & 8732A	2.0:1 - 8735A	2.0:1 - 8731B & 8732B	2.2:1 - 8733B & 8734B	2.0:1 - 8733A & 8734A	2.2:1 - 8735B
1.8:1 - 8731A & 8732A	2.0:1 - 8735A						
2.0:1 - 8731B & 8732B	2.2:1 - 8733B & 8734B						
2.0:1 - 8733A & 8734A	2.2:1 - 8735B						
<p><b>PROCEDURE</b></p> <p>a. With a DC voltage of about -0.8 volts and rated current (stamped on label - underside) applied to BIAS input, measure SWR at ends of specified frequency range.</p> <p>b. If SWR is excessive clean RF input and output connectors and recheck.</p>	<p><b>TEST RESULTS (see Note 1)</b></p> <p>Date _____</p> <p>PIN Mod Serial No. _____</p> <p>SWR _____ at a frequency of _____</p> <p>Measured forward bias current _____</p>						
COMMENTS (if any) _____ _____							
<p>6. MINIMUM INSERTION LOSS (DB). When back-biased less than:</p> <table style="width: 100%; border: none;"> <tr> <td style="width: 50%;">1.5 dB - 8731A</td> <td style="width: 50%;">2.0 dB - 8731B, 8732A, 8733A</td> </tr> <tr> <td>3.0 dB - 8733B</td> <td>3.5 dB &amp; 4.0 dB - 8732B (see Note 3)</td> </tr> <tr> <td>4.0 dB - 8734A &amp; 8735A</td> <td>5.0 dB - 8734B &amp; 8735B</td> </tr> </table>		1.5 dB - 8731A	2.0 dB - 8731B, 8732A, 8733A	3.0 dB - 8733B	3.5 dB & 4.0 dB - 8732B (see Note 3)	4.0 dB - 8734A & 8735A	5.0 dB - 8734B & 8735B
1.5 dB - 8731A	2.0 dB - 8731B, 8732A, 8733A						
3.0 dB - 8733B	3.5 dB & 4.0 dB - 8732B (see Note 3)						
4.0 dB - 8734A & 8735A	5.0 dB - 8734B & 8735B						
<p><b>PROCEDURE</b></p> <p>a. With +5 volts DC applied to BIAS input, measure insertion loss at high end of frequency band and all other points of interest.</p>	<p><b>TEST RESULTS (see Note 1)</b></p> <p>Date _____</p> <p>PIN Mod Serial No. _____</p> <p>Insertion Loss _____ at a frequency of _____</p>						
COMMENTS (if any) _____ _____							
<p><b>NOTES</b></p>							
<p>1. The test results column provided opposite each test procedure is not provided to allow a complete test record but rather to allow test result comparisons for a specific PIN Modulator measured under the same conditions at different time intervals.</p> <p>2. When back-biased the SWR of the 8732B should be less than 1.6:1 for RF frequencies between 1.8 and 4.0 GHz and less than 2.0:1 between 4.0 and 4.5 GHz.</p> <p>3. Minimum insertion loss for the 8732B is less than 3.5 dB for RF frequencies between 1.8 and 4.0 GHz and less than 4.0 dB between 4.0 and 4.5 GHz.</p>	<p>4. The leakage current although not an actual specification is the only method of checking diodes for leakage and general condition.</p> <p>5. To check rise and decay times a Sampling Oscilloscope such as the hp Model 185B should be used.</p> <p>6. Typical Forward Bias Input Resistance may be calculated by applying 3 or 4 milliamperes of DC current at a negative potential, measuring the negative potential. Specification: For "A" model PIN Modulators, approximately 300 ohms <math>\pm</math>100 ohms; For "B" model PIN Modulators, approximately 100 ohms <math>\pm</math>50 ohms.</p>						



Table 3. Recommended Test Equipment

Instrument Type	Critical Specifications	Check	Recommended Model
<u>Equipment For All Models</u>			
DC Power Supply	Outputs: $\pm 0.2$ to 20 Vdc 0.5 to 10 mA Impedance: 100 $\Omega$	All	HP 6216A
DC Voltmeter and DC Ammeter	Voltage Range: $\pm 3$ to 20 Vdc Current Range: 0.5 to 10 mA Accuracy: $\pm 3\%$	All	HP 412A or HP 410C
SWR Meter and Crystal Detector	Freq: of PIN Modulator, Modulated at 1000 Hz $\pm 2\%$ rate Calibration: Square Law Freq Resp: $\pm 0.5$ dB Accuracy: $\pm 1\%$	Minimum Insertion Loss	HP 415E (Meter) and HP 423A (Det.)
Resistor	100K $\Omega$ 1/4 W 10%	Leakage Current	- -
RF Source	Freq: of PIN Modulator Residual FM: <50 KHz Power Out: 3 mW	All (except leakage current)	8614B (8731) 8616B (8732) 8690B (H01-8693B) 8690B (H01-8694B) 694B (8735)
<u>Equipment For "A" Models Only</u>			
RF Attenuator	Freq: of PIN Modulator Atten: 30 dB Accuracy: $\pm 2$ dB	Dynamic Range	Weinschel 210-30 (all coaxial models) HP X382 A (8735A)
Power Meter	Power: up to 10 mW Freq: of PIN Modulator Instrument Accuracy: $\pm 3\%$ Calibration: mW and dB	Dynamic Range	HP 431B or HP 432A (Meter) HP 478A (Mount 8731A thru 34A) HP X486A* (Mount 8734A/ 8735A)
<u>Equipment For "B" Models Only</u>			
Power Meter	Freq: of PIN Modulator Power: up to 2 W Accuracy: $\pm 6\%$	Dynamic Range	HP 434A
Spectrum Analyzer	Freq: of PIN Modulator Calibration: logarithmic in dB/cm Sensitivity: -90 dBm (-65 dBm for 8733B/34B/35B)	Dynamic Range	HP 851B (display section) and HP 8551B (RF Section)
Microwave Amplifier	Freq Range: of 8733B/34B/ or 35B Power Out: 1 W from 1 mW input	Dynamic Range	HP 491C (8733B) HP 493A (8733B) HP 495A (8734B and 8735B)
* Note: For use with 8734A, an X281A Coaxial to waveguide and a male-to-male type N adapter must be used			

\* Note: For use with 8734A, an X281A Coaxial to waveguide and a male-to-male type N adapter must be used

APPENDIX I

BACKDATING

MANUAL CHANGES

MODEL SERIES 8730A/B  
PIN MODULATORS

Make all backdating corrections in this manual according to changes below.

SERIAL PREFIX OR NUMBER	MAKE MANUAL CHANGES	SERIAL PREFIX OR NUMBER	MAKE MANUAL CHANGES
8731-5B: 815-	A, B		
8732A: 816-	B		

CHANGE A:

Paragraph 41 and 42:

Add desiccant, stock no. 9240-0007; Escutcheon, stock no. 08731-203; Desiccant retaining screw, 08731-216.

Change bias input escutcheon stock no. 08731-2028 to 08731-203.

CHANGE B:

Table 1; SWR specification:

Change SWR specification from "1.8, 1.8 to 4.0 GHz: 2.0, 4.0 to 4.5 GHz" to "1.8, 1.8 to 4.5 GHz".