

HP 8711A RF NETWORK ANALYZER SERVICE MANUAL

SERIAL NUMBERS

This manual applies directly to any HP 8711A network analyzer with the serial prefix 3325A.

©Copyright HEWLETT-PACKARD COMPANY 1992
1400 FOUNTAINGROVE PARKWAY, SANTA ROSA, CA 95403 U.S.A.

MANUAL PART NO. 08711-90108

Printed: JULY 1993
Edition 1



CERTIFICATION

Hewlett-Packard Company certifies that this product met its published specifications at the time of shipment from the factory. Hewlett-Packard further certifies that its calibration measurements are traceable to the United States National Institute of Standards and Technology (NIST, formerly NBS), to the extent allowed by the Institute's calibration facility, and to the calibration facilities of other International Standards Organization members.

WARRANTY

This Hewlett-Packard system product is warranted against defects in materials and workmanship for a period corresponding to the individual warranty periods of its component products. Computer and computer peripherals are warranted for a period of 90 days. Instruments are warranted for a period of one year. During the warranty period, Hewlett-Packard Company will, at its option, either repair or replace products which prove to be defective.

Warranty service for products installed by HP and certain other products designated by HP will be performed at Buyer's facility at no charge within HP service travel areas. Outside HP service travel areas, warranty service will be performed at Buyer's facility only upon HP's prior agreement and Buyer shall pay HP's round trip travel expenses. In all other areas, products must be returned to a service facility designated by HP.

For products returned to HP for warranty service, Buyer shall prepay shipping charges to HP and HP shall pay shipping charges to return the product to Buyer. However, Buyer shall pay all shipping charges, duties, and taxes for products returned to HP from another country.

HP warrants that its software and firmware designated by HP for use with an instrument will execute its programming instructions when properly installed on that instrument. HP does not warrant that the operation of the instrument, or software, or firmware will be uninterrupted or error free.

LIMITATION OF WARRANTY

The foregoing warranty shall not apply to defects resulting from improper or inadequate maintenance by Buyer, Buyer-supplied software or interfacing, unauthorized modification or misuse, operation outside of the environmental specifications for the product, or improper site preparation or maintenance.

NO OTHER WARRANTY IS EXPRESSED OR IMPLIED. HP SPECIFICALLY DISCLAIMS THE IMPLIED WARRANTIES OR MERCHANTABILITY AND FITNESS FOR A PARTICULAR PURPOSE.

EXCLUSIVE REMEDIES

THE REMEDIES PROVIDED HEREIN ARE BUYER'S SOLE AND EXCLUSIVE REMEDIES. HP SHALL NOT BE LIABLE FOR ANY DIRECT, INDIRECT, SPECIAL, INCIDENTAL, OR CONSEQUENTIAL DAMAGES, WHETHER BASED ON CONTRACT, TORT, OR ANY OTHER LEGAL THEORY.

ASSISTANCE

Product maintenance agreements and other customer assistance agreements are available for Hewlett-Packard products.

For any assistance, contact your nearest Hewlett-Packard Sales and Service Office. Addresses are provided at the back of this manual.

BP24A.2

SAFETY CONSIDERATIONS

GENERAL

This product and related documentation must be reviewed for familiarization with safety markings and instructions before operation. This product has been designed and tested in accordance with international standards.

SAFETY SYMBOLS



Instruction manual symbol: the product will be marked with this symbol when it is necessary to refer to the instruction manual (refer to Table of Contents).



Indicates hazardous voltages.



Indicates earth (ground) terminal.

WARNING

The WARNING sign denotes a hazard. It calls attention to a procedure, practice, or the like, which, if not correctly performed or adhered to, could result in personal injury. Do not proceed beyond a WARNING sign until the indicated conditions are fully understood and met.



The CAUTION sign denotes a hazard. It calls attention to an operating procedure, practice, or the like, which, if not correctly performed or adhered to, could result in damage to or destruction of part or all of the product. Do not proceed beyond a CAUTION sign until the indicated conditions are fully understood and met.

BEFORE APPLYING POWER

Verify that the product is configured to match the available main power source per the input power configuration instructions provided in this manual.

If this product is to be energized via an autotransformer make sure the common terminal is connected to the neutral (grounded side of the mains supply).

SERVICING

WARNING

Any servicing, adjustment, maintenance, or repair of this product must be performed only by qualified personnel.

Adjustments described in this manual may be performed with power supplied to the product while protective covers are removed. Energy available at many points may, if contacted, result in personal injury.

Capacitors inside this product may still be charged even when disconnected from their power source.

To avoid a fire hazard, only fuses with the required current rating and of the specified type (normal blow, time delay, etc.) are to be used for replacement.

This is to declare that this product is in conformance with the German Regulation on Noise Declaration for Machines (Laermangabe nach der Maschinenlaermverordnung -3. BGI Deutschland).

Acoustic Noise Emission/Geraeuschemission	
LpA < 70 dB Operator position Normal operation per ISO 7779	LpA < 70 dB am Arbeitsplatz normaler Betrieb nach DIN 45635 t. 19

DECLARATION OF CONFORMITY

according to ISO/IEC Guide 22 and EN 45014

Manufacturer's Name: Hewlett-Packard Company
Manufacturer's Address: Network Measurements Division
1400 Fountaingrove Parkway
Santa Rosa, California 95403
U.S.A.

declares that the product

Product Name: RF Network Analyzer
Model Number: HP 8711A
Product Options: All options

conforms to the following Product Specifications:

Safety: IEC 1010
EMC: EN55011 Class A/CISPR-11 class A
EN50082-1/2-1991
IEC 801-2/1991 4kV CD, 8kV AD
IEC 801-3/1984 3V/m (26-500 MHz)
IEC 801-4/1988 500V

Santa Rosa

6/8/92



(Location)

(Date)

Dixon Browder, Quality Manager

HP 8711A RF NETWORK ANALYZER

CONTENTS

OVERVIEW AND PREVENTIVE MAINTENANCE

INTRODUCTION	1-1
ORGANIZATION OF SERVICE MANUAL	1-1
PREVENTIVE MAINTENANCE	1-2
Clean the CRT	1-2
Check the RF Front Panel Connectors	1-2
Line Fuse Replacement	1-2
SERVICE TEST EQUIPMENT	1-3

PERFORMANCE TESTS

VERIFYING INSTRUMENT PERFORMANCE	2-1
When to Perform the Operator's Check	2-2
When to Perform the Manual Performance Tests	2-2
When to Perform the Automated Performance Tests	2-2
Performance Test Notes	2-2
If the Analyzer Fails a Test	2-2
Recommended Test Equipment	2-2
Analyzer Calibration Cycle	2-3
HP 8711A SYSTEM SPECIFICATIONS	2-4
OPERATOR'S CHECK	2-7
To check analyzer operation in transmission mode	2-7
To check analyzer operation in reflection mode	2-8
If the Analyzer Fails the Test	2-8
VERIFYING PERFORMANCE WITH MANUAL TESTS	2-9
Performance Test Worksheet and Record	2-9
2-1. FREQUENCY RANGE AND ACCURACY PERFORMANCE TEST	2-10
If the Analyzer Fails the Test	2-12
2-2. DYNAMIC RANGE PERFORMANCE TEST	2-13
If the Analyzer Fails the Test	2-15
2-3. POWER RANGE AND FLATNESS PERFORMANCE TEST	2-16
If the Analyzer Fails the Test	2-19
2-4. BROADBAND FREQUENCY RESPONSE PERFORMANCE TEST	2-20
If the Instrument Fails the Test	2-21
VERIFYING PERFORMANCE WITH AUTOMATED TESTS	2-22
SETTING UP AN AUTOMATED SYSTEM	2-22
System Hardware Requirements	2-22
System Software Requirements	2-23
BACKING UP THE SOFTWARE PROGRAM	2-25

LOADING AND RUNNING THE TEST SOFTWARE	2-27
To Edit Mass Storage	2-27
To Edit the Device Configuration	2-28
To Run the Performance Tests Program	2-29
To Recover from an Error	2-29
PRINTING PERFORMANCE TEST RESULTS	2-30
2-5. SPURIOUS SIGNALS AUTOMATED PERFORMANCE TEST	2-31
To set up the equipment	2-31
2-6. DYNAMIC ACCURACY AUTOMATED PERFORMANCE TEST	2-34
2-7. ABSOLUTE POWER ACCURACY AUTOMATED PERFORMANCE TEST	2-41
2-8. SYSTEM DIRECTIVITY AND PORT MATCH AUTOMATED PERFORMANCE TEST	2-45
 ADJUSTMENTS	
ADJUSTMENT DESCRIPTION	3-1
FIRMWARE ADJUSTMENTS	3-1
FRACTIONAL-N VCO ADJUSTMENT	3-3
FRACTIONAL-N SPUR ADJUSTMENT	3-5
FREQUENCY ACCURACY ADJUSTMENT	3-9
SET SERIAL NUMBER ADJUSTMENT	3-11
In Case of Difficulty	3-12
LO POWER CORRECTION ADJUSTMENT	3-13
SWITCHED GAIN CORRECTION ADJUSTMENT	3-14
EXTERNAL DETECTOR CORRECTION ADJUSTMENT	3-16
AUX IN CORRECTION ADJUSTMENT	3-17
SOURCE POWER (ALC) CORRECTION ADJUSTMENT	3-18
In Case of Difficulty	3-20
B AMPLITUDE CORRECTION ADJUSTMENT	3-21
TRANSMISSION (B/R) CORRECTION ADJUSTMENT	3-22
REFLECTION (ONE PORT) CORRECTION ADJUSTMENT	3-23
R* AMPLITUDE CORRECTION ADJUSTMENT	3-24
R* FREQUENCY RESPONSE CORRECTION ADJUSTMENT	3-25
B* AMPLITUDE CORRECTION ADJUSTMENT	3-26
STORING AND RECALLING CORRECTION CONSTANTS	3-29
To Permanently Store CCs in the Analyzer	3-29
To Temporarily Store CCs to Disk for Later Recall	3-29
To Recall CCs from Disk	3-29
To Restore Previous CCs after Replacing the A2 CPU Board	3-30
To Replace Suspected Incorrect CCs	3-30
To Archive Current CCs to Disk	3-30
If "ROM Appears to be Blank" Message is Displayed at Power-up	3-30
If "Warning: No Correction Constants Installed" Is Displayed at Power-UP	3-30
Step 1. Storing Correction Constants to Disk	3-30
Step 2. Updating or Restoring Firmware	3-31
Step 3. Installing Correction Constants from Disk	3-31
Step 4. Loading Correction Constants from Disk	3-31

TROUBLESHOOTING

HP 8711A SYSTEM TROUBLESHOOTING	4-1
General Notes	4-1
Initial Observations	4-1
Operator's Check	4-2
TROUBLESHOOTING PERIPHERAL PROBLEMS	4-2
DIN Keyboard	4-2
RS-232 Printers and Plotters	4-2
Centronics Printers and Plotters	4-3
HP-IB Systems	4-3
HP-IB Problems with Printers or Plotters	4-3
HP-IB Problems with Disk Drives	4-3
General Checks for HP-IB Systems	4-4
TROUBLESHOOTING THE ANALYZER	4-5
General Notes	4-5
TROUBLESHOOTING POWER SUPPLY (PS) PROBLEMS	4-5
Check the Rear Panel LEDs	4-5
Measure Power Supply Voltages	4-6
Remove Assemblies	4-7
TROUBLESHOOTING DIGITAL GROUP PROBLEMS	4-7
Error During Power-up	4-8
Front Panel Problems	4-13
TROUBLESHOOTING SOURCE GROUP PROBLEMS	4-13
Phase Lock Problems	4-13
Source Power Problems	4-14
Spurious Signals	4-14
TROUBLESHOOTING RECEIVER PROBLEMS	4-15
Trace at +/-200 dB	4-15
Random Noise Trace	4-16
Spurs in the Data Trace	4-16
Incorrect Data	4-16
Receiver Power Problems	4-17
DETAILED TROUBLESHOOTING	4-18
Digital Group	4-18
Source Group	4-18
Receiver Group	4-19
HP8711A OVERALL BLOCK DIAGRAM	4-20
SERVICE KEY MENUS	
INTRODUCTION	5-1
INTERNAL DIAGNOSTICS AND ADJUSTMENTS SUMMARY	5-1
INSTRUMENT SETTINGS MENU	5-2
TESTS AND ADJUSTMENTS MENU	5-2
SELF-TESTS	5-2
ADJUSTMENTS	5-4

SERVICE MODES SUMMARY	5-5
INSTRUMENT INFO	5-6
SERVICE UTILITIES MENU	5-6
MORE SVC UTILITIES MENU	5-7
MEAS CAL OPTIONS MENU	5-7
VIEW ARRAY MASTER MENU	
VIEW ARRAY INTERPOL MENU	5-8
UPDATE CORR CONST MENU	5-8
ANALOG BUS MENU	5-9
ANALOG BUS NODES	5-9
MISCELLANEOUS SERVICE FUNCTIONS	5-11
Clearing Nonvolatile Memory (SRAM)	5-11
Correction Constant Procedures	5-11
Upgrading Firmware	5-12
Making a Current Correction Constants Disk (Optional)	5-12
UPGRADING THE FIRMWARE	5-12
HP-IB COMMAND REFERENCE FOR SERVICE	5-14
Syntax Summary	5-14
Softkey SCPI Commands	5-14
Alphabetical SCPI Command Summary	5-15
 THEORY OF OPERATION	
INTRODUCTION	6-1
SYSTEM THEORY	6-1
ANALYZER FUNCTIONAL GROUPS	6-2
POWER SUPPLY THEORY	6-2
DIGITAL CONTROL THEORY	6-3
A1 Front Panel	6-3
A2 CPU	6-3
A7 Display	6-4
A8 Floppy Disk Drive	6-4
SOURCE THEORY	6-4
A3 Fractional-N/Reference	6-4
A4 Source	6-4
RECEIVER THEORY	6-6
 REPLACEABLE PARTS	
INTRODUCTION	7-1
TOOLS REQUIRED	7-1
HOW TO ORDER PARTS	7-1
Save Money by Ordering R-E (Rebuilt-Exchange) Assemblies	7-1
Save Time by Calling (800) 227-8164	7-2
MAJOR ASSEMBLIES	7-2

A1 FRONT PANEL ASSEMBLY	7-3
How to Remove the Front Panel Assembly	7-3
A2 CPU ASSEMBLY	7-4
How to Remove the CPU Assembly	7-5
A3 FRAC-N/REFERENCE ASSEMBLY	7-6
How to Remove the Frac-N/Reference Assembly	7-7
A4 SOURCE ASSEMBLY	7-8
How to Remove the Source Assembly	7-8
A5 RECEIVER ASSEMBLY	7-9
How to Remove the Receiver Assembly	7-10
A6 POWER SUPPLY	7-11
How to Remove the Power Supply Assembly	7-11
A7 DISPLAY ASSEMBLY	7-12
How to Remove the Display Assembly	7-13
A8 FLOPPY DISK DRIVE	7-14
How to Remove the Disk Drive Assembly	7-14
CABINET AND MISCELLANEOUS PARTS	7-15
POST REPAIR PROCEDURES	7-17

Overview and Preventive Maintenance

INTRODUCTION

This *Service Manual* is a complete guide to servicing the HP 8711 RF network analyzer. It is part of a manual set which includes operating and programming information.

This manual contains information required to maintain, test, troubleshoot, and repair the analyzer. The rest of this section consists of three main parts:

- a description of how this manual is organized,
- preventive maintenance instructions, and
- equipment (and its critical specifications) required to monitor or adjust the instrument.

ORGANIZATION OF SERVICE MANUAL

Tabs divide the major sections of this manual. The tab titles (in italics) and contents follow.

- *1 Overview and Preventive Maintenance* is described above.
- *2 Performance Tests* are step-by-step procedures that verify certain individual performance specifications of the analyzer.
- *3 Adjustments* provides instructions for adjustment and alignment of the instrument after repair or replacement of an assembly. Some of the adjustments are semi-automated procedures for altering correction constants (non-mechanical adjustments).
- *4 Troubleshooting* contains an operator's check, service procedures to identify bad assemblies, and an overall block diagram.
- *5 Service Key Menus* documents the instrument functions accessed from the **Service** softkey. These functions include test, adjustment, control, troubleshooting routines, and upgrading firmware.
- *6 Theory of Operation* explains the overall operation of the instrument, the division into functional groups, and the operation of each group.
- *7 Replaceable Parts* provides illustrations of the replaceable assemblies and miscellaneous parts, part numbers, and ordering information. It also contains part removal procedures.
- *8 Instrument History* contains backdating information required to make this manual compatible with earlier shipment configurations of the instrument.

PREVENTIVE MAINTENANCE

Preventive maintenance consists of two tasks. It should be performed at least every six months--more often if the instrument is used daily on a production line or in a harsh environment.

Clean the CRT

Use a soft cloth and, if necessary, a mild cleaning solution. HP part number 8500-2163 is one such solution.

Check the RF Front Panel Connectors

Visually inspect the front panel connectors. The most important connectors are those to which the DUT is connected, typically the RF cable end or the RF IN connector. All connectors should be clean and the center pins centered. The fingers of female connectors should be unbroken and uniform in appearance.

If you are unsure whether the connectors are good, gage the RF IN and RF OUT connectors to confirm that their dimensions are correct.

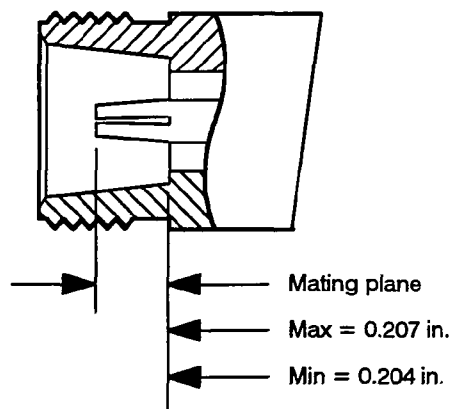

Figure 1-1. Maximum and Minimum Recession of Center Conductor

Line Fuse Replacement

The line fuse does NOT need to be replaced periodically, only when it fails. The line module on the rear panel contains a spare fuse. To order additional fuses, use the part number listed on the rear panel and in Figure 7-6 of the "Replaceable Parts" chapter of this manual.

SERVICE TEST EQUIPMENT

Figure 1-2. HP 8711A Service Test Equipment (1 of 2)

Instrument Required	Critical Specifications	Recommended Model or HP Part Number	Use ²
HP 9000 series 200/300 Controller	No substitute	NOT model 226	P,A
BASIC 5.0 or higher	No substitute	HP 98618A	P,A
Test Software	No substitute	08711-10009	P,A
Spectrum Analyzer	No substitute	HP 8566B	P,A
Frequency Counter	Freq: 300 kHz to 1.3 GHz Accuracy: 1 ppm	HP 5342A	P,A
Power Meter	No substitute	HP 437B, 438A	P,A,T
Power Sensors:			
50 ohm	Freq: 300 kHz to 1.3 GHz Power range: -30 to +20 dBm	HP 8482A	P,A,T
75 ohm	Freq: 300 kHz to 1.3 GHz Power range: -30 to +20 dBm Impedance: 75Ω (required for option 1EC instruments only)	HP 8483A ¹	P,A,T
Low power	Freq: 300 kHz to 1.3 GHz Power range: -70 to -20 dBm	HP 8481D option H70 with 11708A	
Step Attenuator	80 dB range in 10 dB steps with calibration data at 30 MHz	HP 8496A/G option 001, H17	P,A
Function Generator	No substitute	HP 8116A	P,A
Attenuator/Switch Driver (optional)	No substitute	HP 11713A	P,A
Type-N Calibration Kit	No substitute	HP 85032B, HP 85036B ¹	P,A,T
20 dB Type-N Attenuator	Need calibration data at 6 or more frequencies from 300 kHz to 1.3 GHz Impedance: 75 ohms	HP 8491A option 020 0955-0670 ¹	P P
30 dB SMA Attenuator	SWR < 1.2 Attenuator accuracy ± 1.0 dB	HP 8493A option 030	A
30 MHz Bandpass Filter	Center frequency 30 MHz 3 dB BW < 5 MHz > 70 dB rejection below 20 MHz and above 40 MHz	9135-0475	P,A
10 dB Type-N Attenuator	SWR < 1.2	HP 8491A option 010	A
Power Divider	SWR < 1.25 Output tracking between arms: < 0.4 dB Max input power: +30 dBm	HP 11636A	P,A,T
Oscilloscope	100 MHz, 50 ohm input	any	T

Figure 1-2. HP 8711A Service Test Equipment (2 of 2)

Instrument Required	Critical Specifications	Recommended Model or HP Part Number	Use ²
Power Splitters: 50 ohm	Freq: 300 kHz to 1.3 GHz Tracking between outputs: ≤ 0.15dB Input SWR: ≤ 1.15 Equivalent output SWR: ≤ 1.10	HP 11667A	P,A
75 ohm	Freq: 300 kHz to 1.3 GHz Tracking between outputs: ≤ 0.2 dB Equivalent output match: 30 dB Input port match: 20 dB Nominal insertion loss: < 8 dB	HP 11850D ¹	P,A
Minimum Loss Pads (2)	No substitute	HP 11852B ¹	P,A
Type-N Cables: 50 ohm (2)	Return loss ≥ 24 dB	8120-4781	P,A,T
75 ohm	Return loss ≥ 24 dB	8120-2408 ¹	
BNC cables: 50 ohm		8120-1839	O,P,A
75 ohm		5063-0061 ¹	
175 MHz Bandpass Filter	Passband in the range of 300 kHz to 1.3 GHz	0955-0598 (included with HP8711)	O
Adapters: Type-N (m)/BNC (f) (2 required)	50 ohm 75 ohm	1250-1476, 1250-0780 1250-1535 ¹	O
Type-N (m)/N (m)	50 ohm	1250-0778, 1250-1475	P
Type-N (f)/N (f)	75 ohm	85036-60014 (p/o 85036B)	P
BNC (m)/N (f)	50 ohm	1250-0077	P
Cable	SMA (m)/SMA (m)	5021-0899 (p/o service tool kit)	A
Service Tool Kit	No substitute	08711-60010	A,T
Digital Voltmeter		Any	A,T
HP-IB Cables (3 or 4)	No substitute	HP 10833A/B/C	P,A
Dual Output DC Power Supply	2 independent supplies, ± 10V	HP 6234A, 6205C	A
1. Needed only for instruments with option 1EC (75 ohm). 2. Use Column: O=Operator's Check P=Performance Tests A=Adjustments T=Troubleshooting			

Performance Tests

This chapter contains manual and automated procedures that show you how to confirm that an HP 8711 network analyzer is performing to its specifications. The chapter is organized as indicated below:

Verifying Instrument Performance

- When to Perform the Operator's Check
- When to Perform the Manual Performance Tests
- When to Perform the Automated Performance Tests
- Performance Test Notes
- If the Analyzer Fails a Test
- Recommended Test Equipment
- Analyzer Calibration Cycle

HP 8711A Specifications

Operator's Check

Verifying Performance with Manual Tests

- Performance Test Worksheet and Record
- 2-1. Frequency Range and Accuracy Performance Test
- 2-2. Dynamic Range Performance Test
- 2-3. Power Range and Flatness Performance Test
- 2-4. Broadband Frequency Response

Verifying Performance with Automated Tests

- Setting up an Automated System
- Backing-up the Software Program
- Loading the Software
- Printing Performance Test Results
- 2-5. Spurious Signals Automated Performance Test
- 2-6. Dynamic Accuracy Performance Test
- 2-7. Absolute Power Accuracy Performance Test
- 2-8. System Directivity and Port Match Automated Performance Test

Calculation Worksheet for HP 8711 Performance Tests

Performance Test Record

VERIFYING INSTRUMENT PERFORMANCE

This chapter contains three types of procedures to confirm an HP 8711 is performing correctly:

- operator's check
- manual performance tests
- automated performance tests

When to Perform the Operator's Check

Use this operational check for incoming inspection or any time you want to quickly confirm that the analyzer is performing correctly.

When to Perform the Manual Performance Tests

Perform these tests to check the analyzer against its specification or typical values in these areas:

- frequency range and accuracy
- dynamic range
- power range flatness
- broadband frequency response

When to Perform the Automated Performance Tests

Perform these tests with a controller to check the analyzer against its specifications or typical values in these areas:

- spurious signals
- dynamic accuracy
- absolute power accuracy
- system directivity and port match

Performance Test Notes

The tests can be used for incoming inspection, preventative maintenance, troubleshooting, and calibration. The tests should also be done following repairs, verifying that the problem has been fixed. Refer to the "Post-Repair Procedures" figure in the "Replaceable Parts" chapter for a listing of the tests to do when replacing a particular assembly. The tests can be done in any order. However, "Operator's Check" should be done first, since this test could indicate an instrument failure before doing the performance tests.

The specifications and supplemental operating characteristics are listed in Figure 2-1 and individually at the beginning of each test. All the performance tests can be completed in about 3 hours, not including instrument warm-up time of one hour.

If the Analyzer Fails a Test

Refer to the final paragraph of each test procedure for suggestions and references to resolve analyzer operation problems.

Recommended Test Equipment

The recommended test equipment for performance tests is listed at the beginning of each test procedure. Other equipment can be used if it meets the critical specifications listed in the table of service test equipment in chapter 1. However, the procedure is based on the recommended model or part number.

Note



The listed 75 ohm equipment is only required for an HP 8711 with option 1EC (75 ohm impedance).

Analyzer Calibration Cycle

Analyzer calibration consists of performing the “Operator’s Check” and all of the performance tests. This should be done at least once per year.

If spurious signal levels are not critical for the analyzer applications used, you can perform a limited calibration by omitting the spurious signals test. This eliminates the need of a spectrum analyzer for calibration.

HP 8711A SYSTEM SPECIFICATIONS

Specifications describe the instrument's warranted performance over the temperature range of $25 \pm 5^\circ \text{C}$. Broadband mode characteristics apply from 10 to 1300 MHz. Narrowband mode characteristics apply from 300 kHz to 1300 MHz

Source Characteristics

Frequency

Range: 300 kHz to 1300 MHz

Resolution: 1 Hz

Accuracy: (synthesized) $<5\text{ppm}$

RF output power

Leveled range:

Standard:

0 to +16 dBm, ≤ 1000 MHz

0 to 13 dBm, >1000 MHz

Option 1EC: 75 ohm

0 to +13 dBm, ≤ 1000 MHz

0 to +10 dBm, >1000 MHz

Option 1E1: 60 dB step attenuator

reduces maximum RF output power by 3 dB

Power Flatness: (test port)

Standard: ± 1.0 dB

Option 1EC: 75 ohm ± 1.5 dB

Option 1E1: step attenuator ± 2.0 dB

Option 1EC with 1E1: ± 2.0 dB

Signal purity

Harmonics:

<-20 dBc, <1 MHz

<-30 dBc, >1 MHz

Receiver Characteristics

Dynamic range:

Standard:

Narrowband mode:

>60 dB (+10 to <-50 dBm), ≤ 5 MHz

>90 dB (+10 to <-80 dBm), >5 MHz

Broadband mode:

>66 dB (+16 dBm to <-50 dBm)

Option 1EC: 75 ohm

Narrowband mode:

>54 dB (+7 to -47 dBm), ≤ 5 MHz

>84 dB (+7 to -77 dBm), >5 MHz

Broadband mode:

>63 dB (+16 dBm to <-47 dBm)

Maximum input level:

Narrowband mode: +10 dBm (0.8 dB compression)

Broadband mode: +16 dBm (0.55 dB compression)

Test Set Characteristics¹

Reflection Measurements

Test Port Match: 20 dB

System Directivity: 40 dB

Dynamic Accuracy (Narrowband)

Dynamic accuracy is the receiver's accuracy versus input power level.

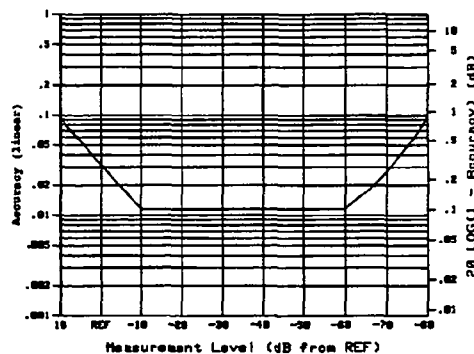

Figure 2-1. HP 8711 Specifications and Supplemental Operating Characteristics (1 of 2)

SUPPLEMENTAL OPERATING CHARACTERISTICS

Supplemental operating characteristics are typical but non-warranted performance characteristics. They are representative of most instruments, but not necessarily tested in each. They can be used in applying the instrument. Broadband mode characteristics apply from 10 to 1300 MHz. Narrowband mode characteristics apply from 300 kHz to 1300 MHz.

Source Supplemental Characteristics

Frequency

Aging: <3 ppm 1st year, <1 ppm/year thereafter

Drift:

With temperature (0 to 55°C) ±5 ppm

With 10% change in line voltage <1 Hz

With 3:1 load SWR <1Hz

External reference Input: 10 MHz (BNC),

>-5 dBm required

Signal Purity

Non-Harmonic Spurious:

>50 kHz from carrier

<-20 dBc, <1 MHz

<-30 dBc, >1 MHz

<50 kHz from carrier

<-25 dBc, 300 kHz to 1300 MHz

Phase noise: -70 dBc/Hz at 10 kHz offset

Residual AM:

<-50 dBc in 100 kHz bandwidth

Residual FM: <1.5 kHz peak, 30 Hz to 15 kHz

post detection bandwidth

Sweep time: at maximum system bandwidth

Number of Data Points	Sweep Time
51	<50 ms
101	<60 ms
201	<70 ms
401	<110 ms
801	<210 ms
1601	<400 ms

Receiver Supplemental Characteristics

Input damage level: +20 dBm, ±25 VDC

Noise reduction techniques:

Averaging, system bandwidth reduction

Test Set Characteristics¹

System Directivity

(with default calibration): 30 dB

System Directivity

(with user calibration): 40 dB

Transmission Measurements: >1 MHz

Transmission Port Match: 20 dB

Reflection Port Match: 14 dB

System Accuracy^{1,2}

Transmission accuracy:³

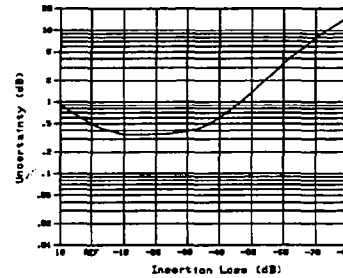

Reflection accuracy:⁴

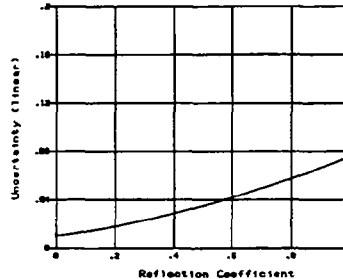

Absolute power accuracy: (broadband)

Total power accuracy = absolute power accuracy + frequency response (±0.5 dB)

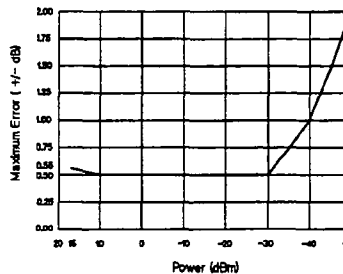

Figure 2-1. HP 8711 Specifications and Supplemental Operating Characteristics (2 of 3)

Aux Input Characteristics

Calibrated range: $\pm 10\text{V}$

Accuracy: $\pm (3\% \text{ of reading} + 20 \text{ mV})$

Damage Level: $>14 \text{ VDC}$ when instrument is operating

1. These characteristics apply for an environmental temperature of $25 \pm 5^\circ\text{C}$ with less than 1° deviation from the calibration temperature, at a narrow system bandwidth with spur avoidance activated. Reflection test port characteristics apply at reflection test ports, after a user defined reflection calibration.
2. These measurement uncertainty curves utilize an RSS model for the contributions of random errors such as noise, typical connector repeatabilities, and a worst-case model for the contributions of dynamic accuracy and residual systematic errors.
3. The graphs shown for transmission measurements assume a well-matched device, and do not include errors due to device reflection effects.
4. The graph for reflection measurement uncertainty applies to a one-port device.

Figure 2-1. HP 8711 Specifications and Supplemental Operating Characteristics (2 of 2)

OPERATOR'S CHECK

Use this procedure for an operational check of the analyzer. You make transmission and reflection measurements on a bandpass filter, and compare the results to typical plots.

To set up the equipment

The list below shows the equipment you use to check the operation of the analyzer.

Equipment	Recommended Model or HP Part Number	
	50 Ohm (std.)	75 Ohm (opt. 1EC)
Bandpass filter	0955-0598	0955-0598
BNC cable	8120-1839	5063-0061
Adapters type-N(m)/BNC(f) (2)	1250-1476	1250-1535

Note



The filter listed was shipped with your HP 8711, but any other filter can be used if its passband is between 300 kHz and 1.3 GHz. However, if another filter is used, the typical plots given will not apply.

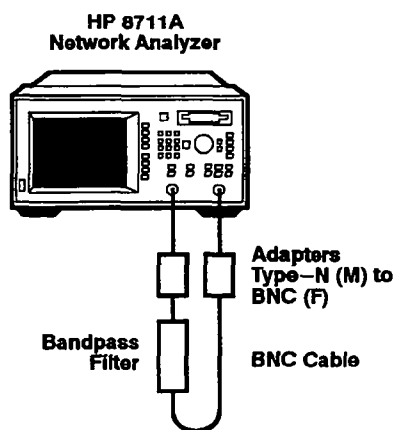

Figure 2-2. Equipment Setup for Checking Instrument Operation

1. Connect the equipment as shown in Figure 2-2.
2. Press **PRESET** on the analyzer.

To check analyzer operation in transmission mode

3. Press **BEGIN** **Filter** **Transmission** to put the analyzer in a mode to measure the transmission of a filter.

4. Press **FREQ** **Center** **177** **MHz** **Span** **300** **MHz** to set the analyzer for a center frequency of 177 MHz and a span of 300 MHz.
5. Press **SCALE** **Autoscale** **MARKER** **Marker Search** **Mkr--Max** to measure the filter.
 Note: if you are not using the filter supplied with the instrument, your displayed measurement may look different.

Compare the displayed measurement to the plot shown in Figure 2-3a.

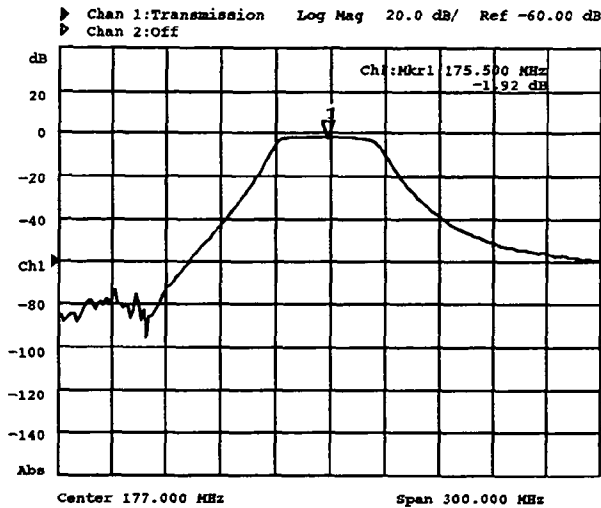

a) Transmission Measurement

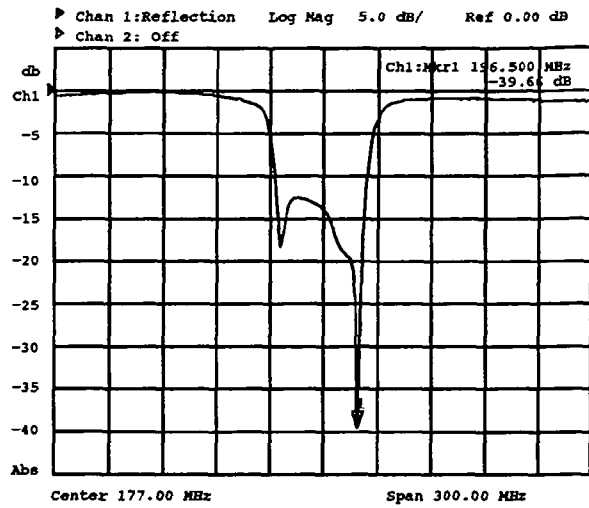

b) Reflection Measurement

Figure 2-3. Typical Bandpass Filter Measurement Plots

To check analyzer operation in reflection mode

6. Press **BEGIN** **Filter** **Reflection** to put the analyzer in a mode to measure the reflection of a filter.
7. Press **SCALE** **Autoscale** **MARKER** **Marker Search** **Mkr--Min** to measure the filter.

Compare the displayed measurement to the plot shown in Figure 2-3b.

If the Analyzer Fails the Test

Refer to the “Troubleshooting” chapter in this manual.

VERIFYING PERFORMANCE WITH MANUAL TESTS

This section contains procedures that show you how to check the performance of the HP 8711 using the following manual tests:

- frequency range and accuracy
- dynamic range
- power range and flatness

Performance Test Worksheet and Record

A calculation worksheet and performance test record are provided for you to calculate test results and record values. The worksheet and test record are located at the end of this chapter.

2-1. FREQUENCY RANGE AND ACCURACY PERFORMANCE TEST

Use this procedure to test the analyzer's frequency accuracy over its entire frequency range. The specifications the instrument performance is tested against are listed below:

Frequency range specification:

300 kHz to 1300 MHz \pm frequency accuracy

Frequency accuracy specification:

< 5 ppm ($25^{\circ}\text{C} \pm 5^{\circ}\text{C}$)

To set up the equipment

The list below shows the equipment you use in this test. You can use any equipment that meets the critical specifications (listed in the table of service test equipment in chapter 1). However, the procedure is based on the recommended model or part number.

Warm-up time is 1 hour.

Equipment	Recommended Model or HP Part Number	
	50 Ohm (std.)	75 Ohm (opt. 1EC)
Frequency counter	5342A	5342A
Minimum Loss Pad		11852B
Adapter type-N(m)/BNC(f)	1250-0780	1250-0780
BNC cable	8120-1839	8120-1839
Type-N cable	8120-4781	8120-4781

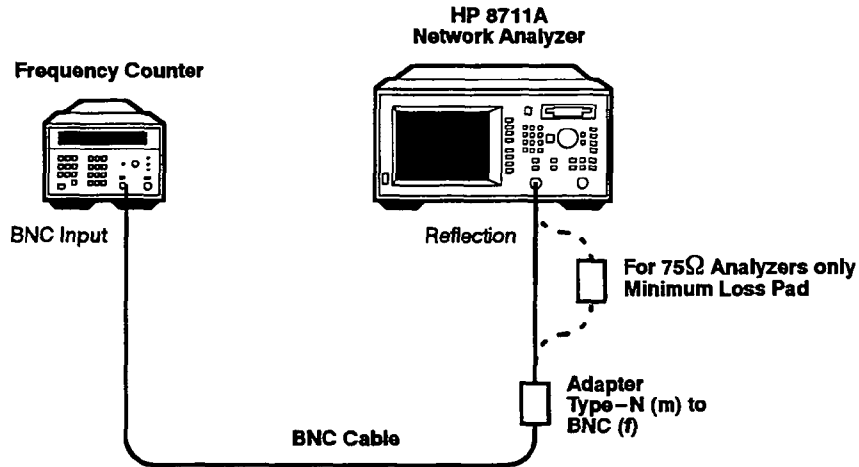

a) Setup for Frequencies < 500 MHz

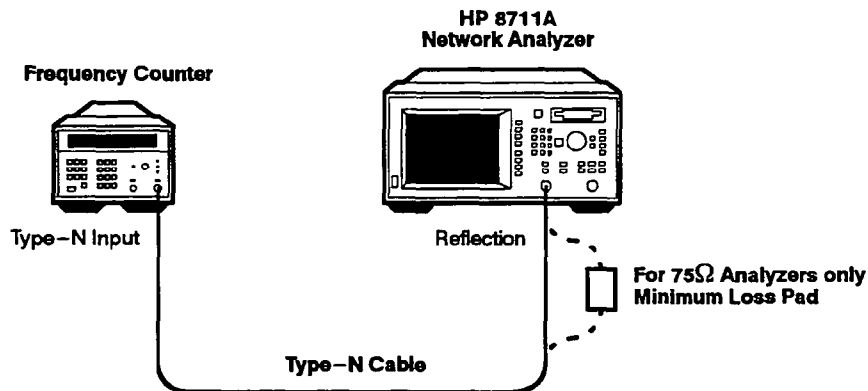

b) Setup for Frequencies > 500 MHz

Figure 2-4. Frequency Range and Accuracy Test Setups

1. Connect the equipment as shown in Figure 2-4a.
2. Set the frequency counter input switches to the 10 Hz - 500 MHz and 50 ohm positions.
3. Press **PRESET** on the analyzer.

To check frequency range and accuracy

4. Press **FREQ** **CW** **300** **KHz** to set a CW frequency of 300 kHz.

Write the frequency counter reading on the test record located at the end of this chapter.

5. Repeat the previous step for the frequencies (through 100 MHz) listed on the test record.

The upper and lower specification limits and the measurement uncertainties are listed for each frequency.

6. Connect the equipment as shown in Figure 2-4b.
7. Set the frequency counter input switch to the 500 MHz – 18 GHz position.
8. Repeat step 4 for the remaining frequencies listed on the test record.

If any frequency measured is close to the specification limits (either in or out of specification), check the time base accuracy of the counter.

If the Analyzer Fails the Test

If the analyzer fails by a large margin at all frequencies (especially if the deviation increases with frequency), the master time base probably needs adjustment. Refer to “Frequency Accuracy Adjustment” and “Fractional-N VCO Adjustment” in the “Adjustments” chapter.

If the analyzer still fails the test, refer to the “Troubleshooting” chapter.

2-2. DYNAMIC RANGE PERFORMANCE TEST

Dynamic range is the difference between the receiver's maximum specified input level and the receiver's noise floor. This test has two parts. In the first part, you check compression in narrowband mode to verify the receiver's accuracy at high input levels. (Broadband compression is tested in the "Absolute Power Accuracy Performance Test.") In the second part, you measure the receiver noise floor. The specifications are listed below:

	Standard (50 Ω)	Opt. 1EC (75Ω)
Compression		
Narrowband:	0.8 dB compression at +10 dBm	0.8 dB compression at +7 dBm
Noise Floor		
Narrowband:		
300 kHz to 5 MHz	<-50 dBm	<-47 dBm
5 MHz to 1.3 GHz	<-80 dBm	<-77 dBm
Broadband:	<-50 dBm	<-47 dBm

To set up the equipment

The list below shows the equipment you use in this test. You can use any equipment that meets the critical specifications (listed in the table of service test equipment in chapter 1). However, the procedure is based on the recommended models.

Warm-up time is 1 hour.

Equipment	Recommended Model or HP Part Number	
	50 Ohm (std.)	75 Ohm (opt. 1EC)
Type-N cable	8120-4781	8120-2408
Attenuator, 20 dB w/data ¹	8491B opt. 020	0955-0670
Coaxial Termination (from cal kit)	909F opt. 012	909E
Short (from cal kit)	85032-60008	85036-60012

1. Attenuator must have calibration data report for frequencies measured. To obtain attenuator calibration data, send attenuator to a calibration lab.

To Measure Compression

1. Enter the data values for the calibrated 20 dB attenuator as POSITIVE numbers in column (a) of Figure 2-16. Data at frequencies other than those listed in the table may be substituted, providing they are a good selection of data points over the full frequency span of the HP 8711. If you do use data for other frequencies that are not listed, write the actual frequencies for the data in Figure 2-16.

2. Connect a thru cable between the REFLECTION and TRANSMISSION ports of the analyzer:
 - For 50Ω analyzers, press: **PRESET** **POWER** **Level** **10** **ENTER** **AVG** **System Bandwidth** **Narrow** **CAL** **Normalize** .
 - For 75Ω analyzers, press: **PRESET** **POWER** **Level** **7** **ENTER** **AVG** **System Bandwidth** **Narrow** **CAL** **Normalize** .
3. Connect the attenuator between the two ports of the analyzer. Press **MARKER** and enter the first frequency listed in Figure 2–16. Record the marker reading in column (b) of Figure 2–16.
4. Enter the next frequency listed in Figure 2–16 and record the marker reading in column (b). Repeat for all frequencies listed.
5. Calculate the values for column (c) by adding the values of (a) and (b). Record the worst–case value of column (c) in the Performance Test Record.

To Measure Noise Floor

1. Connect a thru cable between the REFLECTION and TRANSMISSION ports of the analyzer.
2. Press **PRESET** **AVG** **System Bandwidth** **Narrow** **SWEEP** **Alt Sweep ON** **DISPLAY** **More Display** **Split Display** **Split** **FREQ** **Start** **5** **MHz** **CHAN 1** **FREQ** **Stop** **5** **MHz** .

This sets up a 300 kHz to 5 MHz sweep on channel 1 and a 5 MHz to 1.3 GHz sweep on channel 2.

3. Press **CAL** **Normalize** to normalize the trace on channel 1. Press **CHAN 2** **CAL** **Normalize** **MENU** **Trigger** **Hold** to normalize the trace on channel 2, then put channel 2 into hold mode.
4. Remove the cable. Connect a termination (load) to the REFLECTION port and a short to the TRANSMISSION port.
5. Press **CHAN 1** **SCALE** **Autoscale** **AVG** **Avg Factor** **4** **ENTER** **Average ON** **MENU** **Trigger** **Single** . Wait for the sweep to finish, then press **Single** again. Repeat until four sweeps are completed.
6. Press **MARKER** **Marker Search** **Min–Max** to find the peak noise value. Write the marker value for 300 kHz to 5 MHz in the test record.
7. Repeat steps 5 and 6 for channel 2, recording the results for 5 MHz to 1.3 GHz in the performance test record. Note: to see the entire trace of channel two, press **SCALE** **Autoscale** when the four sweeps are completed.
8. Reconnect the through cable between the two ports of the analyzer.
9. Press **PRESET** **CHAN 1** **Power** **MENU** **Number of Points** **51** **ENTER** **FREQ** **Start** **10** **MHz** **AVG** **System Bandwidth** **Narrow** .

This sets up channel 1 to measure B* with a narrow system bandwidth.

10. Press **CAL** **Detector Zero** **Manual Zero** **Prior Menu** **Normalize** to turn off automatic detector zeroing and normalize the trace.
11. Remove the cable. Connect a termination to the REFLECTION port and a short to the TRANSMISSION port.
12. Press **SCALE** **Autoscale** **AVG** **Avg Factor** **64** **ENTER** **Average ON** . Wait for 30 seconds for the analyzer to take and average 64 sweeps, then press **MENU** **Trigger** **Hold** .

13. Press **MARKER** **Marker Search** **Hfr-Max** to find the peak noise value. Write the marker value on the test record.

If the Analyzer Fails the Test

If the analyzer fails the test, suspect the receiver assembly. Refer to the “Switched Gain Correction” and “B* Amplitude Correction” procedures in the “Adjustments” chapter.

If the analyzer still fails the test, refer to the “Troubleshooting” chapter.

2-3. POWER RANGE AND FLATNESS PERFORMANCE TEST

Use this procedure to test the power level range and flatness of the analyzer source. You step the source over a series of CW frequencies at three different power levels. Then you use the minimum and maximum specified power limits as two of these power levels to test the power range. At each power level, you determine the flatness from the peak-to-peak variation in power over the frequency range. Since this test only checks a few points across the frequency range, you also make a slow sweep to check for power holes. The specifications the instrument performance is tested against are listed below:

Power range specifications:

Frequency Range	50Ω		75Ω (Opt 1EC)	
	Standard	Opt. 1E1	Standard	Opt. 1E1
≤1000 MHz	0 to +16 dBm	-60 to +13 dBm	0 to +13 dBm	-60 to +10 dBm
>1000 MHz	0 to +13 dBm	-60 to +10 dBm	0 to +10 dBm	-60 to +7 dBm

Power flatness specifications:

standard: ±1.0 dB (2 dB peak-to-peak)

option 1EC (75Ω): ±1.5 dB (3 dB peak-to-peak)

option 1E1 (step attenuator for 50Ω and 75Ω): ± 2.0 dB (4 dB peak-to-peak)

To set up the equipment

The list below shows the equipment you use in this test. You can use any equipment that meets the critical specifications (listed in the table of service test equipment in chapter 1). However, the procedure is based on the recommended models.

Warm-up time is 1 hour.

Equipment	Recommended Model or HP Part Number	
	50 Ohm (std.)	75 Ohm (opt. 1EC)
Power meter	436A/438A/437B	436A/438A/437B
Power sensor	8482A	8483A
Low level power sensor (for option 1E1 only)	8481D opt. H70 (w/reference attenuator)	8481D opt. H70 (w/reference attenuator)
Minimum Loss Pad (for opt. 1EC & 1E1)		11852B

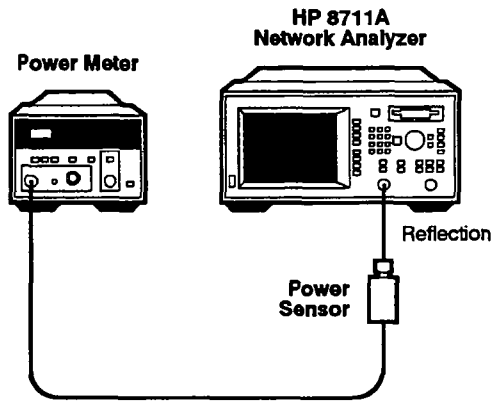

Figure 2-5. Power Range and Accuracy Test Setup

1. Zero and calibrate the power meter.
 - For 50 ohm analyzers, use an HP 8482A power sensor.
 - For 75 ohm analyzers, use an HP 8483A power sensor.
2. Connect the power sensor to the REFLECTION port, as shown in Figure 2-5.
3. Press **PRESET** on the analyzer.

To check the power range and flatness

The main procedure is written for standard 50 ohm instruments. Refer to the specifications table at the beginning of this test procedure for the power ranges of the other instrument options. The calculation worksheet and test record list the power levels tested for all of the instrument options.

For all instruments:

1. Press **POWER** **16** **ENTER** to set the power to +16 dBm.

The power level setting is for a standard 50 ohm HP 8711. Locate the Figure 2-17 that applies to your instrument option, located at the end of this chapter. Set the analyzer power to the first nominal power level listed in Figure 2-17.

2. Press **FREQ** **CW** **300** **KHZ** to set the CW frequency to 300 kHz.
3. Set the power meter to the correct cal factor for the analyzer frequency.

Write the measured value in Figure 2-17.

4. Repeat steps 2 and 3 for the remaining frequencies listed in Figure 2-17. Note: some instruments output less than +13 dBm at 1.3 GHz; see Figure 2-18.

Write the maximum and minimum power values on the calculation worksheet in Figure 2-18. Calculate the test result by subtracting the minimum value from the maximum value. Write the maximum and minimum values and the test result on the test record.

5. Repeat steps 1 through 4 for the power level settings (through 0 dBm) in Figure 2-17.

If your analyzer does NOT have option 1E1 (step attenuator), continue with “To check power holes” later in this procedure. If your analyzer DOES have option 1E1, continue with either the 50 or 75 ohm step below.

For 50 ohm Instruments with Step Attenuators (option 1E1):

6. Remove the HP 8482A power sensor and replace it with an HP 8481D option H70. Zero and calibrate the power meter.

Calibrate the power sensor with the 30 dB reference attenuator connected to the power meter. Set the power level of the analyzer to -20 dBm. Connect the sensor directly to the analyzer (do not use the reference attenuator).

7. Repeat steps 1 through 4 for power level settings of -20 dBm and -60 dBm.

For 75 ohm Instruments with Step Attenuators (option 1E1):

8. Repeat steps 1 through 4 at a power level setting of -20 dBm.

9. Remove the HP 8483A power sensor and replace it with an HP 8481D. Zero and calibrate the the power meter.

Calibrate the power sensor with the 30 dB reference attenuator connected to the power meter. When you connect the sensor to the analyzer, do not use the reference attenuator.

10. Connect the HP 11852B minimum loss pad between the analyzer REFLECTION port and the power sensor.

11. Repeat steps 2 through 4 again, but DO NOT record the maximum and minimum values in Figure 2-18 or the test record.

Subtract the HP 8481D readings from the HP 8483A readings to determine the loss of the HP 11852B.

12. Press **POWER** **-60** **ENTER** to set the analyzer power to -60 dBm.

13. Repeat steps 2 through 4.

Add the HP 11852B loss to each HP 8481D reading to obtain the corrected power values for each frequency.

Write the corrected minimum and maximum power values and the test result in Figure 2-18 and the test record.

To check power holes

1. Connect the equipment as shown in Figure 2-5.

- For a 50 ohm HP 8711, use an HP 8482A power sensor.
- For a 75 ohm HP 8711, use an HP 8483A power sensor.

2. Press **FREQ** **CW** **650** **MHz** to set the analyzer frequency to 650 MHz.

3. For a standard 50 ohm HP 8711, press **POWER** **Level** **16** **ENTER** to set the power to +16 dBm.

Set the analyzer power to the first power level listed for your instrument option under “Power Hole Check” on the test record.

4. Set a reference power level on the power meter.

Press **dB/REF** for an HP 436A

Press **REL** for an HP 438A

5. Press **FREQ** **START** **300** **KHZ** **STOP** **1300** **MHZ** to set the analyzer sweep range for a start frequency of 300 kHz and a stop frequency of 1300 MHz.

6. Press **SWEEP** **Sweep time** **300** **sec** to set the analyzer sweep time to 300 seconds (5 minutes).

Read the power levels displayed on the power meter for the 5 minute sweep and verify that all points are within a 2 dB limit. Write pass or fail on the test record located at the end of this chapter.

If any points fail, enter the power meter cal factor for that point and check again.

7. Repeat steps 3 through 6 for the second power level listed on the test record.

- For 50 ohm option 1E1, use an HP 8481D option H70 power sensor for the –60 dBm setting.
- For 75 ohm option 1E1, put an HP 11852B minimum loss pad between the REFLECTION port and the HP 8481D option H70 power sensor.

If the Analyzer Fails the Test

If the analyzer fails the test, check that the power meter and power sensor are operating to specification. Also inspect all connectors for damage.

Refer to “Source Power Correction” in the “Adjustments” chapter.

If the analyzer still fails the test refer to the “Troubleshooting” chapter.

2-4. BROADBAND FREQUENCY RESPONSE PERFORMANCE TEST

Use this procedure to check the frequency response of the broadband B* (power) input. There are no warranted specifications for this characteristic, but typical values are provided.

The frequency response, combined with the absolute power accuracy, determines the total power accuracy of the B* input. In this test, a reference power level is set at a CW frequency of 30 MHz. The B* input is normalized to this level. Then the CW frequency is changed, and the change in output power is subtracted from the change in B* input level for each frequency to determine the frequency response.

Broadband frequency response typical characteristic:

± 0.5 dB

Equipment	Recommended Model or HP Part Number	
	50 Ohm (std.)	75 Ohm (opt. 1EC)
Power meter	HP 436A/437B/438A	HP 436A/437B/438A
Power sensor	HP 8482A	HP 8483A
Power divider	HP 11636A	HP 11850D
Minimum loss pad		HP 11852B
Type-N cable, 50 ohm	HP p/n 8120-4781	HP p/n 8120-4781
Type-N cable, 75 ohm		HP p/n 8120-2408
75 ohm termination		HP 909E

1. Zero and calibrate the power meter. Set the cal factor to the correct value for 30 MHz.
2. Connect the equipment as shown in the figure below.

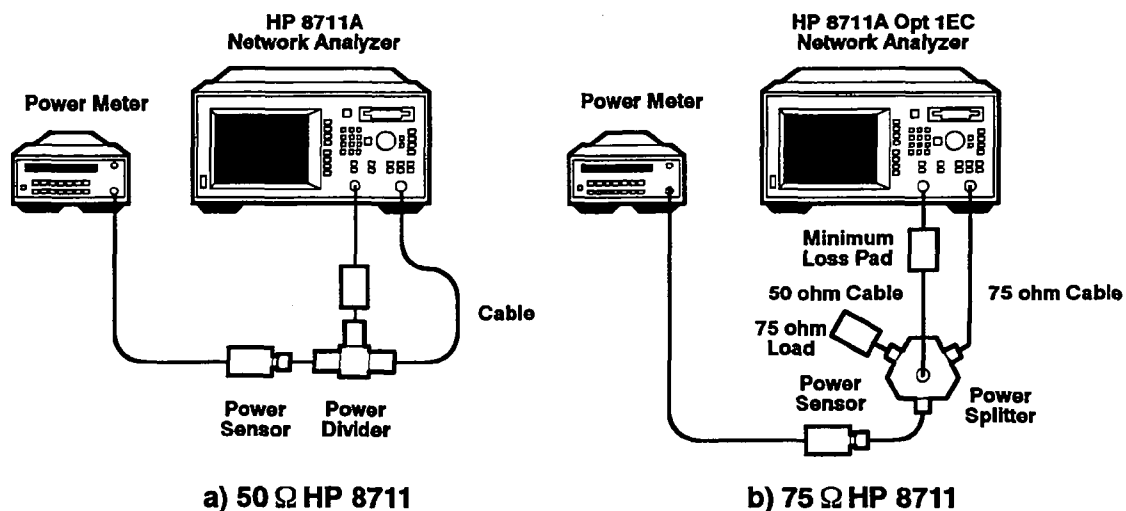

Figure 2-6. Setup for Broadband Frequency Response Test

3. On the analyzer, press **PRESET** **CHAN 1** **Power** **FREQ** **CW** **30** **MHz** **MARKER** to make a B* measurement at 30 MHz.
4. Press **POWER** **Level**.
 - On a 50 ohm analyzer, press **6** **ENTER**. Adjust the power level with the front panel knob for a power meter reading of 0 dBm +/- 0.2 dB.
 - On a 75 ohm analyzer, press **7** **ENTER**. Adjust the power level with the front panel knob for a power meter reading of -6.5 dBm +/- 0.2 dB.
5. Press the **REL** button on the power meter (**dBREF** on an HP 436A) to make future power measurements relative to this level.
6. On the analyzer, press **CAL** **Normalize**.
7. On the analyzer, press **FREQ** **CW** **10** **MHz**. Record the marker value in column (a) of Figure 2-19 on the calculation worksheet.
8. Enter the correct cal factor on the power meter for this frequency. Record the power meter reading in column (b) of Figure 2-19 on the calculation worksheet.
9. Repeat steps 7 and 8 for the other frequencies listed in Figure 2-19.
10. Exchange the power sensor and cable connections to the power splitter. Repeat steps 3 through 9. Record the marker readings in column (c) and power meter readings in column (d) on the calculation worksheet.
11. The receiver's frequency response is the average of the variations measured with each configuration. Calculate the value for each frequency using $0.5(a-b+c-d)$, and record the result in column (e).
12. Record the maximum and minimum values of column (e) on the test record card.

If the Instrument Fails the Test

Check the power sensor, power divider, splitter, and cable.

There is no adjustment for this characteristic. Failures that are close to the typical values are acceptable. However, if the measured values differ greatly from the typical values, there may be a problem with the receiver board. Refer to the Troubleshooting chapter of this manual.

VERIFYING PERFORMANCE WITH AUTOMATED TESTS (Software Revision A.01.00)

This section of the performance tests contains instructions and setup diagrams for automated tests. Automated tests require an HP 9000 series 200/300 desktop computer, associated peripherals and the HP 8711A Performance Test and Adjustment Programs disk. This disk also contains performance test software for the HP 86200A and 85201A RF detectors, which are accessories for the HP 8711. The tests do require you to interact with the program and are best described as semi-automated.

This section is organized as follows:

- setting up an automated system
- backing-up the software program
- loading and running the test software
- printing performance test results
- spurious signals automated performance test
- dynamic accuracy automated performance test
- absolute power accuracy automated performance test
- system directivity and port match automated performance test

SETTING UP AN AUTOMATED SYSTEM

System Hardware Requirements

Controllers. You can use any HP 9000 series 200/300 controllers except model 226 to run the performance tests. .

Disk Drive and Printer. The automated tests require a disk drive for mass storage and a printer.

The software is formatted double-sided and provided on a 3.5 inch floppy disk. There are many compatible disk drives. The following drives are recommended in Figure 2-7 as a convenience only; most double-sided HP drives will work. (The required measurement instrumentation is listed in the test procedure.)

Model Number	Command Set
HP 9122D	CS80
HP 9133D/H	CS80
HP 9153A	CS80

Figure 2-7. Compatible Disk Drives

To record test results, you must have a printer. The printer generates a hardcopy of all automated test results and are output in test record format. Some compatible printers are listed in Figure 2-8.

HP 2225A ThinkJet
 HP 2671G/2673A Thermal Printer
 HP 9876A Thermal Line Printer

Figure 2-8. Compatible Printers

Step Attenuator: Some of the automated tests use a coaxial step attenuator. It can be either of these:

HP 8496A: manual

HP 8496G: programmable, use with HP 11713A attenuator driver as part of an automated system.

System Software Requirements

BASIC Operating System. The performance tests software requires HP BASIC versions 5.0 or higher.

Binaries and Drivers. The software also requires several binaries, code modules of computation, and I/O capabilities. The required binaries (language extensions and drivers) are listed in the "To Load the Operating System and Binaries" procedure located later in this section.

To Connect the Automated System

1. Make the connections as shown in Figure 2-9.

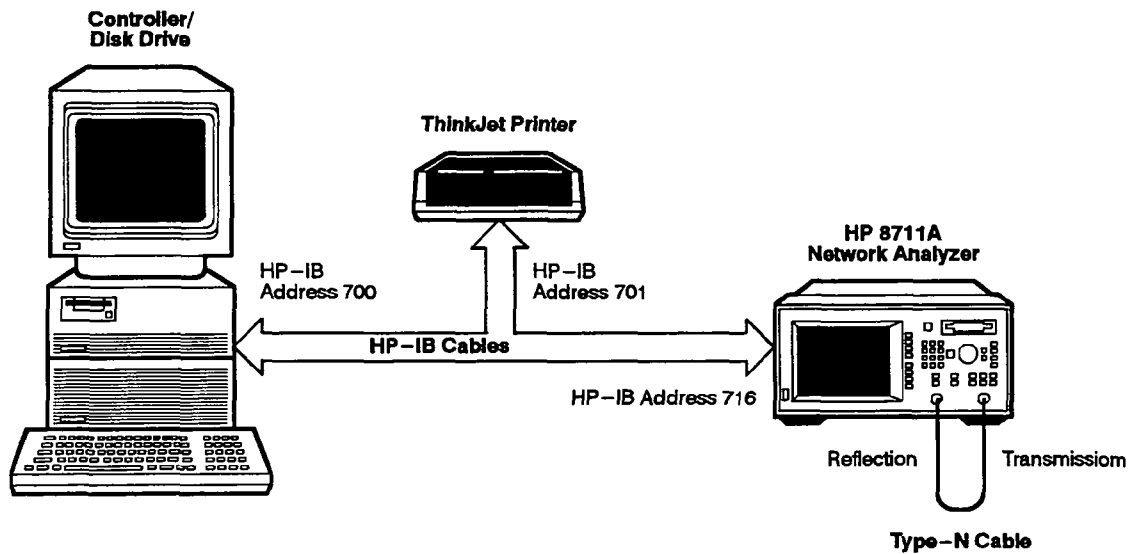

Figure 2-9. Automated System Connections

2. Check that all the HP-IB addresses of the instruments are set as shown below.

Device	HP-IB Address
Network Analyzer	16
Spectrum Analyzer	18
Disk Drive	00
Printer	01

If you want a different address for any of the instruments other than those shown above, refer to the procedure in "To Edit the Device Configuration," located later in this section.

To Load the Operating System and Binaries

1. Insert the BASIC system disk into the disk drive and switch on the computer power.

This loads the BASIC operating system into the controller.

2. On the controller, type:

LIST BIN (press **ENTER** or **RETURN** to execute the command)

All binaries currently contained in memory are listed on the screen. Compare the binaries listed on the screen to those listed below.

Language Extensions	Drivers
ERR	CS80
GRAPH	HPIB
IO	CRTA or CRTB (depends on CRT)
KBD	
MAT	
MS	
CLOCK	

3. If any of the required binaries are missing, insert the Drivers disk (provided with the system) into the disk drive. Load the Configure program by typing:

LOAD "CONFIGURE" (press **RUN** to start the program)

By following the prompts, this program lets you select the necessary binary modules and loads them.

In Case of Difficulty

Refer to the HP BASIC user's documentation for more comprehensive instructions on loading the operating system and binaries.

BACKING UP THE SOFTWARE PROGRAM

To protect the performance tests program, make a working copy of the program disk! You should maintain the master program disk in a write-protected mode to keep it from being written to or initialized (destroyed).

Copy the master program disk using the instructions below, and then use the working copy to perform the tests. If the working copy is damaged or lost, the master is always available.

To Initialize a Disk

A blank disk must be initialized before it can be copied to. You should initialize two disks: one to use as the working copy of the program disk and one to use as the data disk. BASIC and the required binaries must be loaded and running to initialize a disk. (See "To Load the Operating System and Binaries.")

1. Insert a write-enabled blank disk into the disk drive. (In the write-enabled state, the sliding tab covers the hole.) Then type:

INITIALIZE ":msus"

Where *msus* (mass storage unit specifier) is the address of the drive containing the disk to be initialized. The initialization process takes approximately 60 seconds for each disk.

To Copy to a Hard Disk or High Density Flexible Disk

To copy the master performance disk to a storage medium of a larger size, you will have to perform a file-by-file copy instead of copying the entire volume at once. To perform a file copy, follow the instructions below. After typing each command from the keyboard, press **ENTER** or **RETURN** to execute the command.

1. Insert the master program disk into the drive and look at a directory listing by typing:

CAT “:msus”

Where *msus* is the msus of the drive containing the master program disk.

2. If you are copying to a flexible disk, insert the initialized working disk into the second drive. Type:

COPY “filename:master msus” TO “filename:destination msus”

Where *master msus* is the msus of the disk drive containing the master performance disk and *destination msus* is the msus of the flexible or hard disk drive containing the working storage media.

3. Perform step 2 for each file on the master program disk.

EXAMPLE: Your system includes:

- HP 9133H disk drive at HP-IB address 700
- floppy drive is unit 1
- hard disk is unit 0

(The hard disk can be configured as one large volume or several.)

To copy a file from the master program disk in the floppy drive to volume 3 of the hard disk, the copy command syntax would be:

COPY “PERFTEST:,700,1” TO “PERFTEST:,700,0,3”

To Copy from Flexible Disk to Flexible Disk

1. Insert the master disk into one drive and the initialized working disk into the other drive.

2. Type:

COPY “:sourcemsus” TO “:destinationmsus”

where *sourcemsus* is the msus of the drive containing the disk you want to copy, and *destinationmsus* is the msus of the drive containing the initialized working disk.

EXAMPLE: Your system includes:

- HP 9122D dual disk drive at address 700
- master program disk in the left drive
- working disk in the right drive

The copy command syntax would be:

COPY “:,700,0” TO “:,700,1”

LOADING AND RUNNING THE TEST SOFTWARE

The following procedures show you how to load the performance test software and interact with the program. You must have the system connected via HP-IB with the corresponding addresses.

To Load the Test Software

1. Set the msus (mass storage unit specifier) to the address of the drive containing the working copy of the program disk by typing:

MSI “:,XXX,X” (then press **RETURN**)

For example: Your system mass storage is an HP 9122 dual disk drive. Insert the program disk into the left drive and type:

MSI “:,700,0” (then press **RETURN**)

This command sets the current msus to drive 0 of the mass storage device at HP-IB address 700.

2. Load the performance test program by typing:

LOAD “PERFTEST” (then press **RETURN** **RUN**)

During the initialization process, the program searches for the files MS_CONFIG and DEV_CONFIG at the current MSUS. If these files are not present, an error is reported, and you will be given an opportunity to create them.

3. The test software also contains programs for testing the HP 86200A and 86201A RF detectors, so you are asked to choose what device you want to test. Type 1, then press **RETURN** to select the HP 8711.

The first menu you see is the HP 8711 performance test main menu, shown below:

```
[1]→  PERFORMANCE & ADJUSTMENT TESTS
      REPORT GENERATOR
      EDIT MASS STORAGE
      EDIT DEVICE CONFIGURATION
```

To Edit Mass Storage

You do not need to enter this menu if you are using the default setup or you have already modified this portion of the program and haven't reconfigured the system. The default setup is shown below:

- disk drive is HP 9122
- program disk in unit 0
- data disk in unit 1

1. In the main menu, press the down arrow twice and the **SELECT** key once to select EDIT MASS STORAGE.

This menu allows you to establish in which drive the program and data files will reside.

VOLUME LABEL	MSUS	SRM DIRECTORY PATH
DATA DISK	:,700,1	
PROGRAM DISK	:,700,0	

2. Type the msus of the mass storage medium on which the calibration data will be stored.

For example, your system consists of:

- HP 9836A and HP 9122D dual disk drive (HP-IB address 700)
- program disk in unit 0 of HP 9122D
- 5.25 inch floppy for calibration data storage
- HP 9836A internal drive for calibration data disk

You would modify the DATA DISK MSUS column to read:

```
:INTERNAL,4,0
```

The changes you make to the mass storage menu are re-stored into file MS_CONFIG and are in effect the next time the program is run. You won't need to re-edit this menu each time the program is run as long as the system configuration remains the same.

3. If you are using an SRM system, press .

A third column should appear on the screen entitled SRM DIRECTORY PATH. This column must contain the directory path for the volume label, and the MSUS column must contain the remote MSUS ("RE-MOTE").

4. Press to exit this column after editing.
5. Press when you are finished editing the mass storage menu.

The program returns to the HP 8711 performance test main menu.

To Edit the Device Configuration

You do not need to enter this menu if you are using the default setup or you have already modified the addresses and haven't reconfigured the system. The default address are shown below:

Device Name	Device Model	Address
PRINTER	HP2225A	701
POWER METER	HP437/438	713
DUT	HP8711	716
SPECTRUM ANALYZER	HP8566	718
ATTN DRIVER	HP11713A	728
FUNCTION GENERATOR	HP8116A	712

1. Press the down arrow and the key to select DEVICE CONFIGURATION MENU.

This menu contains three columns, two of which are visible on the screen. Use the cursor control keys (left, right, up, down) to select different parts of this menu. DO NOT EDIT COLUMN 1.

2. If necessary, change the printer or power meter model number. If you are using an HP 436A power meter, type HP436A with no spaces. The other four device models listed must remain unchanged for the tests to run.
3. Press **[←]** to view column three.

This selection allows you to input the actual HP-IB hardware addresses of the equipment you will use in the performance tests. Each instrument address is assumed to be the recommended default address for the instrument, with an HP-IB select code of 7.

4. If necessary, change the address on the instrument(s) to match the factory selected defaults. However, if this is not possible, use this menu to edit the program's addresses to match your equipment. When you exit this menu, the changes you make are stored to file DEV_CONFIG and are in effect the next time you run the program. The file DEV_CONFIG lists the instruments required for all the tests.
5. Press **[DONE]** to return to the HP 8711 performance test main menu.

To Run the Performance Tests Program

1. With the arrow at PERFORMANCE & ADJUSTMENT TESTS, press **[ENTER]** or **[RETURN]** or **[SELECT]** to enter the performance test menu. The program checks the analyzer's serial number and the serial number of the TEST_DATA file (if it exists):
 - If the serial numbers match, the program allows you to edit the report header information (date, your name, report number, temperature, and humidity).
 - If the serial numbers do not match, the program erases any existing TEST_DATA file and sets up a new one. It allows you to edit the report header information.
2. Move the arrow pointer to the test you want to run by pressing the arrow keys. (The tests appear in the recommended sequence.) Press **[SELECT]**.

You can rerun tests as many times as necessary without repeating all of the previous menus. However, results from the previous run will be overwritten.

To Recover from an Error

If an error is detected, it is reported to the user with an explanation of the error and the name of the subprogram that detected the error. The error message screen also provides one or more softkeys.

1. Press the **[ABORT]** softkey to return you to the most recent major menu.

The program may respond slowly, especially if the analyzer is making a slow sweep. Be patient.

2. Press the **[REPEAT]** softkey to repeat the routine which just detected the error.

Use this key when, for example, an HP-IB cable is missing and a device does not respond to the controller. Connect the cable and press **[REPEAT]**.

PRINTING PERFORMANCE TEST RESULTS

The program allows you to generate the test results in test record format. The test results can be displayed on the analyzer screen or output to a printer.

1. From the performance tests main menu, use the cursor keys to position the arrow to REPORT GENERATOR and press **SELECT**.
2. To print the test results choose one of the following:
 - If you want the results of all the tests printed, use the cursor key to position the arrow to "Print All" and press **SELECT**.
 - If you only want the results of one test printed, position the arrow to "Select One" and press **SELECT**. Move the arrow to the test you want printed results of and press **SELECT**.
3. Use the cursor keys to choose PRINTER (or CRT if you want the results displayed on the screen). Press **SELECT**.

The program generates the test results and displays them in a performance test record format.

2-5. SPURIOUS SIGNALS AUTOMATED PERFORMANCE TEST

In this procedure a spectrum analyzer measures the harmonics and other spurious signals that may appear in the analyzer source output spectrum. To measure a harmonic of the fundamental frequency, the analyzer is tuned to the fundamental frequency, a power measurement is made for reference, and then the spectrum analyzer is tuned to the harmonic or spur and a measurement is made. The specifications and typical values the instrument performance is tested against are listed below:

Harmonics specification:

300 kHz to 1 MHz: <-20 dBc

1 MHz to 1.3 GHz: <-30 dBc

Non-harmonic spurious typical characteristic:

<-30 dBc

To set up the equipment

The list below shows the equipment used in this test. You can use any equipment that meets the critical specifications (listed in the table of service test equipment in chapter 1). However, the procedure is based on the recommended model or part number.

Warm-up time is 1 hour.

Equipment	Recommended Model or HP Part Number	
	50 Ohm (std.)	75 Ohm (opt. 1EC)
HP BASIC controller (with BASIC 5.0 or higher)	9000 series 200/300	9000 series 200/300
Test software	08711-10009	08711-10009
Spectrum Analyzer	8566B	8566B
Test port cable	8120-4781	8120-4781
Minimum loss pad		11852B
BNC cable (for 10 MHz reference)	8120-1839	8120-1839
Disk drive	9122C/D	9122C/D
ThinkJet Printer	2225A	2225A
HP-IB Cables	as needed	

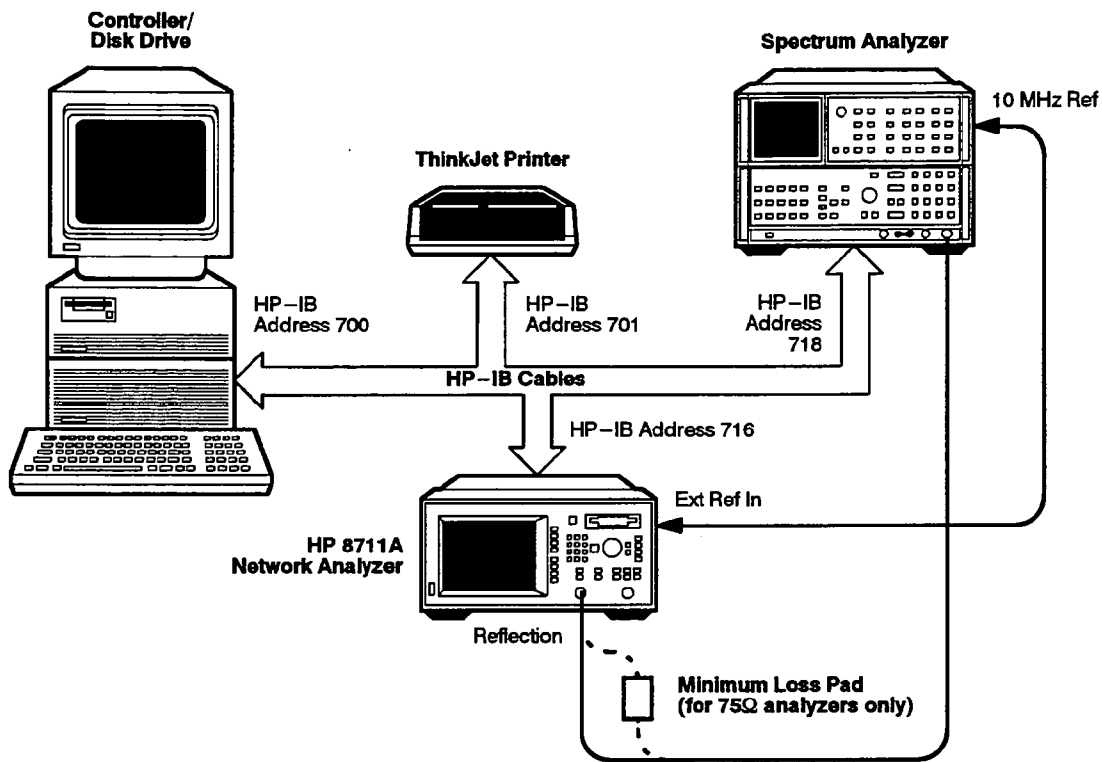

Figure 2-10. Signal Purity Test Setup

1. Connect the equipment as shown in Figure 2-10.
2. Press **PRESET** on the analyzer.

To check the spurious signals

1. If you haven't already done so, load the test software by following the procedure in "Loading and Running the Test Software" located earlier in this section.
2. Select "Spurious Signals" from the performance tests main menu.
3. Select "ALL TESTS," press **SELECT**, and then any key to continue.

As the software program runs, the test results are saved in the controller RAM for a print-out.

4. When the tests are completed, the PASS/FAIL results are displayed on the controller screen.
5. Press **DONE** to return to the performance tests menu.
6. If you are not going to make anymore performance tests, print the test results to either the screen or to a printer. Refer to "Printing Performance Test Results" earlier in this section.

If the Analyzer Fails the Test

If the analyzer fails the test, suspect the fractional-N/reference assembly or the source assembly.

Non-harmonic spur performance is not a warranted specification, so failures are acceptable where the measured value exceeds the typical values by a small amount. Spur performance may be improved by performing the “Fractional-N VCO Adjustment” and “Fractional-N Spur Adjustment.”

If the harmonic test fails or the non-harmonic spurs are much worse than typical, refer to the “Troubleshooting” chapter.

2-6. DYNAMIC ACCURACY AUTOMATED PERFORMANCE TEST

Use this procedure to test the receiver's ability to measure signals as they vary in amplitude over the specified dynamic range. The power is varied from -10 to -80 dBm by inserting a step attenuator, with known attenuation values, in the receiver path. At the beginning of the test, a reference is set at -20 dBm. This provides a repeatability check when the -20 dBm input level is actually tested.

Since the receiver performance is being measured against the step attenuator, the actual attenuation values must be known. You can obtain an HP 8496A/G with calibrated data at 30 MHz by ordering the HP 8496A/G option H17. (This attenuator also meets requirements for use in performance tests for the HP 8752 and 8753 network analyzers.) If you already have an HP 8496A/G, calibration can be obtained from Hewlett-Packard's Loveland Instrument Division Standards Laboratory:

Hewlett-Packard Company
Loveland Instrument Division
Standards Laboratory
815 14th Street S.W.
Loveland, CO 80537

The specifications the instrument performance is tested against are listed below:

Dynamic accuracy specification is the receiver's accuracy versus input power level.

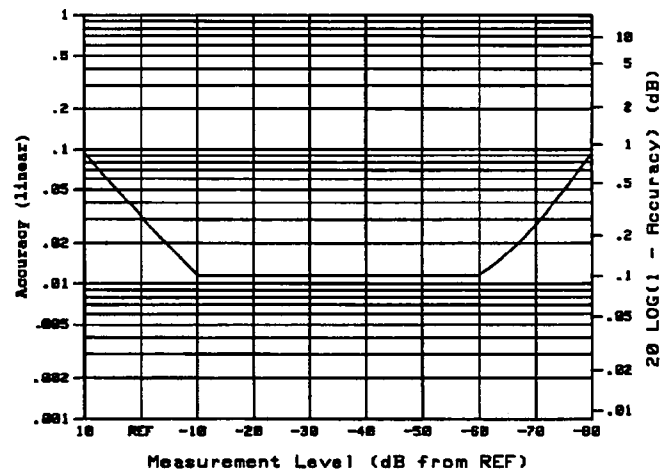

To set up the equipment

The list below shows the equipment used in this test. You can use any equipment that meets the critical specifications (listed in the table of service test equipment in chapter 1). However, the procedure is based on the recommended model or part number.

Warm-up time is 1 hour.

Note

For 75-ohm systems, minimum loss attenuators, adapters, and 75 ohm cables are required.



Equipment	Recommended Model or HP Part Number	
	50 Ohm (std.)	75 Ohm (opt. 1EC)
HP BASIC controller (with BASIC 5.0 or higher)	HP 9000 200/300	HP 9000 200/300
Test software	08711-10009	08711-10009
Step Attenuator, 100 dB	8496A/G opt. 001, H17	8496A/G opt. 001, H17
Power meter	436A/437B/438A	436A/437B/438A
Power sensor	8482A	8483A, 8482A
Adapter type-N(m)/type-N(m)	1250-1475	1250-1475
Adapter type-N(f)/type-N(f)		85036-60014
Minimum loss pads		11852B (2)
Test port cables, 50 ohm (2)	8120-4781	8120-4781
Power splitter	11667A	11667A
Disk drive	9122C/D	9122C/D
ThinkJet Printer	2225A	2225A
Load	00909-60009	00909-60009

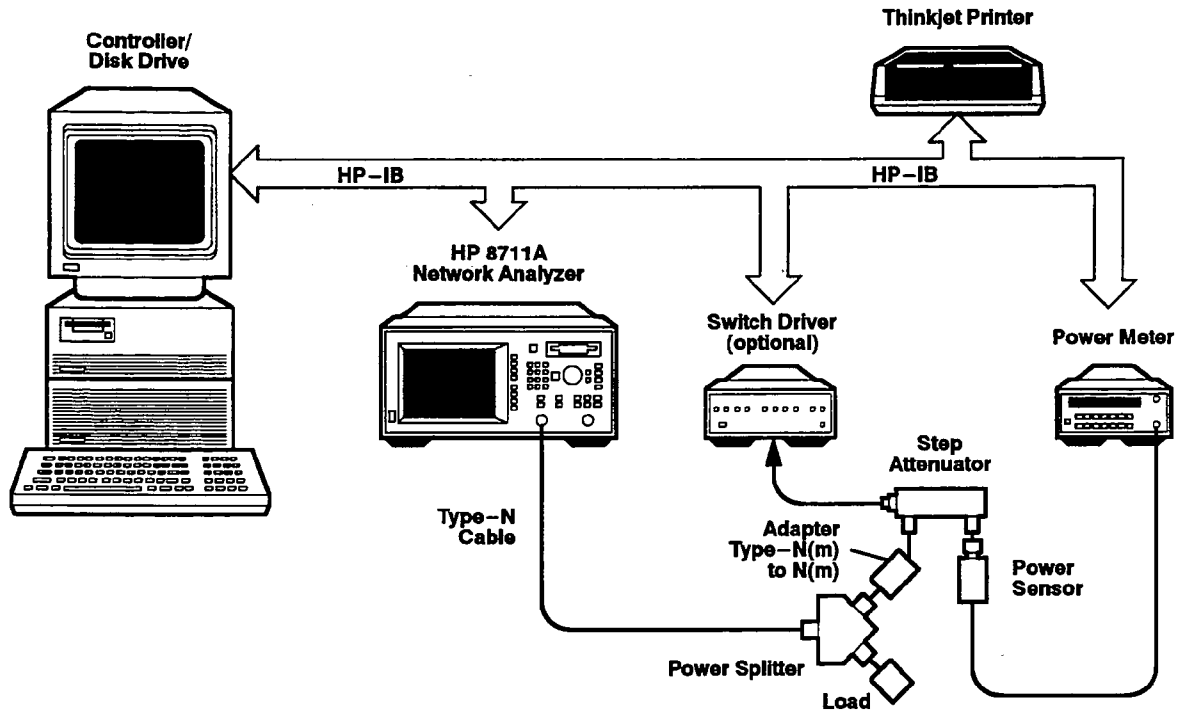

a) For 50-Ohm Systems

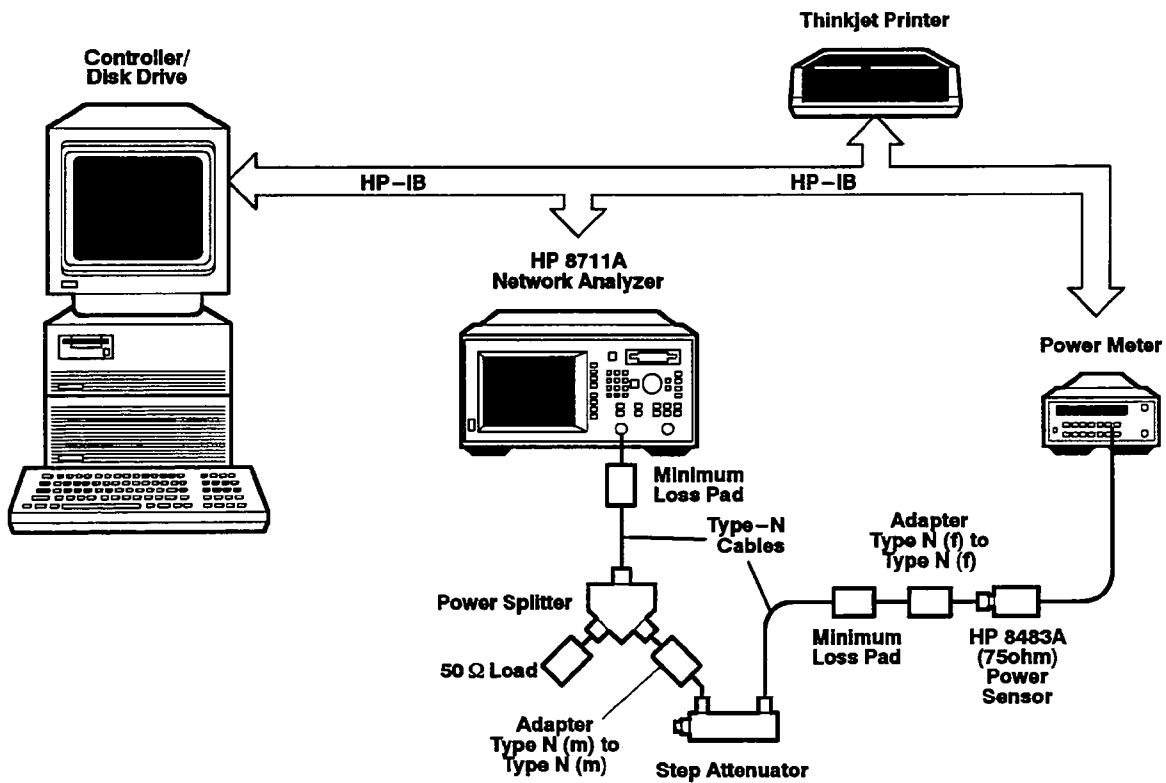

b) For 75-ohm Systems

Figure 2-11. Initial Setup for Dynamic Accuracy

1. Connect the equipment as shown in Figure 2-11 and press **PRESET** on the analyzer.
2. If you haven't already done so, load the automated performance tests software as described in "Loading and Running the Test Software" located earlier in this chapter.
3. Press the cursor keys to move the arrow pointer to the dynamic accuracy test and press **SELECT**.
4. Press any key to continue to the power sensor cal factors menu.
5. Move the arrow pointer to the device you will use to input the power sensor calibration factors. Press **SELECT**.

Read disk can only be selected if you are using a sensor for which you've already saved a calibration factor table.

6. If you selected "Read Disk," another menu appears that allows you to choose the serial number of a power sensor that has an available calibration table. Move the arrow pointer to your choice and press **SELECT**.

The program returns you to the power sensor calibration factors menu.

7. If you selected "Keyboard Entry/Edit", a list of calibration frequencies are displayed on the controller screen. Press **SELECT** and enter the calibration factor for the frequency at the top of the list. (The calibration factors are taken from the label on your power sensor.) Press **ENTER** or **RETURN**.
 - a. Move the arrow pointer to the next calibration factor entry and repeat the action in the paragraph above for the remaining calibration factors. Press **DONE** when you finish entering all the calibration factors.
 - b. Press **SELECT** to store the calibration factor data to disk. Enter the last five digits of the power sensor serial number and press **RETURN** **DONE**.

If you DO NOT want the data stored to disk, press **DONE**.

8. Press any key to continue to the attenuation calibration factors menu. Move the arrow pointer to the device you will use to input the attenuation calibration factors and press **SELECT**.

Read disk can only be selected if you are using an attenuator for which you've already saved a calibration factor table.

9. If you selected "Read Disk," another menu appears that allows you to choose the serial number of an attenuator that has an available calibration table. Move the arrow pointer to your choice and press **SELECT**.

The program returns you to the attenuator calibration factors menu.

10. If you selected “Keyboard Entry/Edit”, a list of attenuation values are displayed on the controller screen. Press **SELECT** and enter the calibration factor for the attenuation value at the top of the list. (The calibration factors are taken from the calibration certificate data.) Press **ENTER** or **RETURN**.
 - a. Move the arrow pointer to the next calibration factor entry and repeat the action in the paragraph above for the remaining calibration factors.
 - b. Press **SELECT** to store the calibration factor data to disk. Enter the last five digits of the attenuator serial number and press **RETURN**.If you DO NOT want the data stored to disk, press **DONE**.
11. Follow the prompts on the controller screen.
12. Connect the power sensor to the attenuator and press any key to continue.
13. Make the connections as shown in Figure 2-12 and press any key to continue.

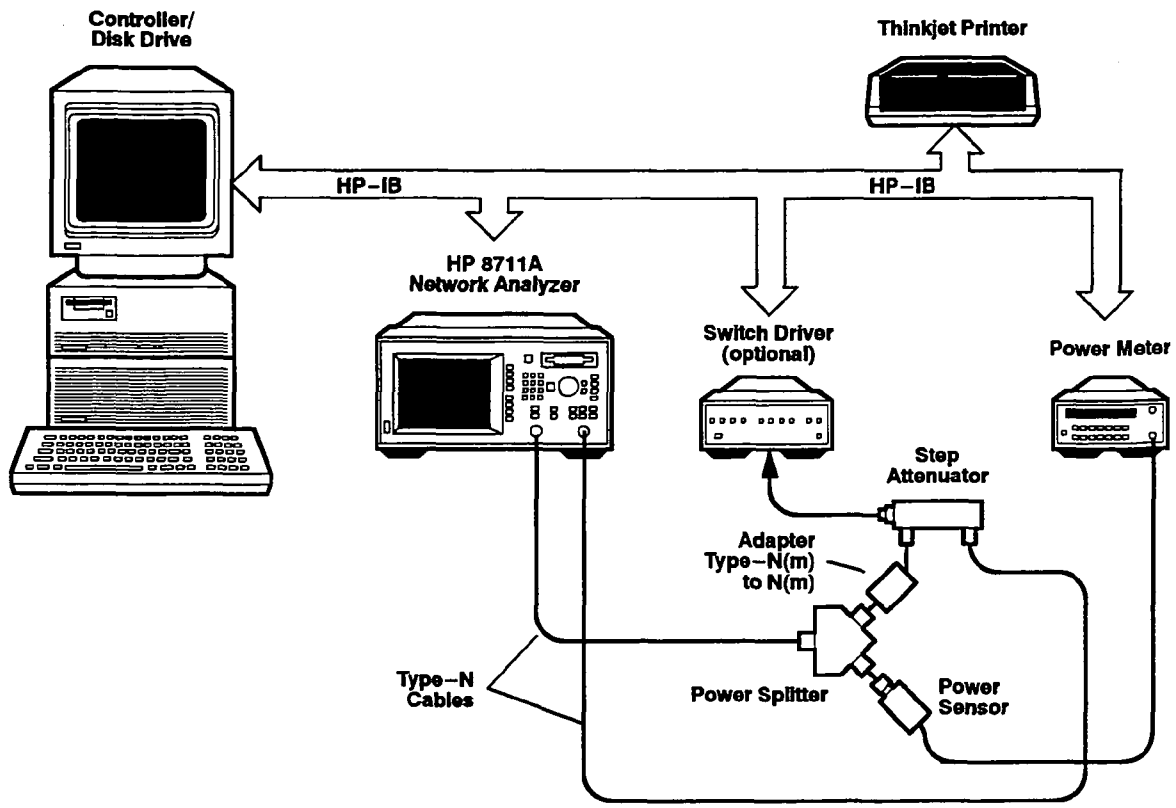

a) For 50-Ohm Systems

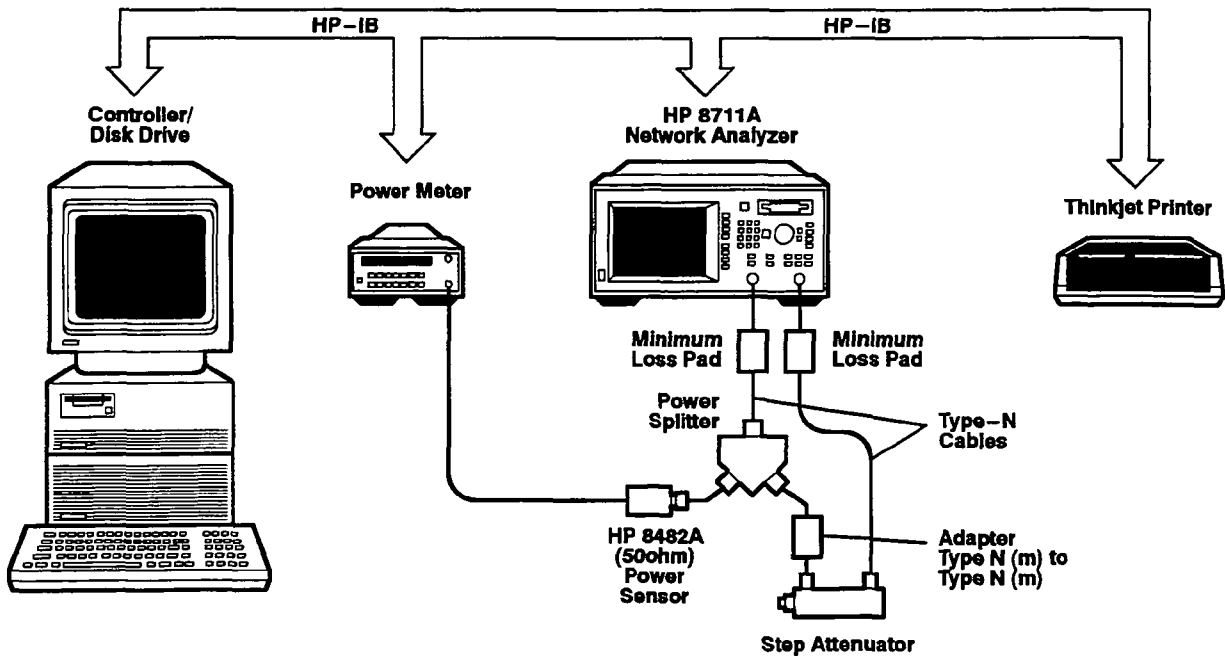

b) For 75-Ohm Systems

Figure 2-12. Measurement Setup for Dynamic Accuracy Test

14. When the test is done, the program returns you to the performance test menu.
15. If you are not going to make anymore performance tests, print the test results to either the screen or to a printer. Refer to “Printing Performance Test Results” located earlier in this chapter.

If the Analyzer Fails the Test

HP 8496G Causes Dynamic Accuracy Failure

Symptom and Cause

The analyzer fails the dynamic accuracy performance test when an HP 8496G programmable attenuator is used. The programmable attenuator has four attenuation sections, two of them 40 dB sections. This can lead to measurement ambiguities at attenuation settings that use just one of the 40 dB attenuators. The following table summarizes which attenuation values use which attenuator sections in the dynamic accuracy performance test.

Attenuation	Section Used			
	1	2	3	4
	10	20	40	40
10	x			
20		x		
30	x	x		
40			x	
50	x		x	
60		x	x	
70	x	x	x	
80			x	x
90	x		x	x
100		x	x	x

Solution

Either get both 40 dB sections calibrated or change the software to access the proper 40 dB section. Note that the 40 dB section used is not the section used in the HP 8752/3 software. To change the software, load the program “dyn_accy” and EDIT “step_attn.” Instructions are provided in the code listing.

If the analyzer still fails the test, suspect the receiver or CPU assembly. Refer to “Switched Gain Correction Adjustment,” and “B Amplitude Correction,” in the “Adjustments” chapter.

Spur problems may also cause this test to fail. Refer to “Fractional-N Spur Adjustment” and “LO Power Correction Adjustment.”

2-7. ABSOLUTE POWER ACCURACY AUTOMATED PERFORMANCE TEST

Absolute power accuracy refers to the analyzer's receiver accuracy when making power measurements in broadband mode (B*). There are no warranted specifications for this characteristic, but values that reflect typical performance are provided.

Use the automated test with the following procedure to check the analyzer's power measurement accuracy. The results indicate how well the analyzer was able to measure its own noise floor in the dynamic range test.

During the test, the controller sets the analyzer to 30 MHz and uses a power meter to accurately set the level of an external source. This external source signal is then measured by the B* input. The measured value is the average of all the points in the trace.

The typical power accuracy for 10 to 1300 MHz is graphed below:

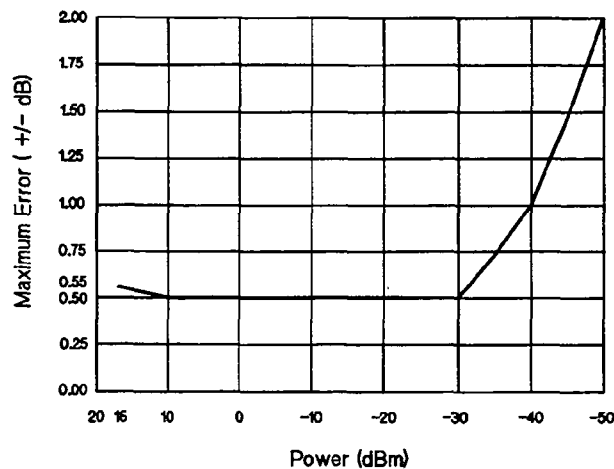

To set up the equipment

The list below shows the equipment used in this test. You can use any equipment that meets the critical specifications (listed in the table of service test equipment in chapter 1). However, the procedure is based on the recommended model or part number.

Warm-up time is 1 hour.

Equipment	Recommended Model or HP Part Number	
	50 Ohm (std.)	75 Ohm (opt. 1EC)
HP BASIC controller (with BASIC 5.0 or higher)	9000 series 200/300	9000 series 200/300
Test software	08711-10009	08711-10009
Signal generator	8116A	8116A
Power divider	11636A	
75 ohm power splitter		11850D
Power meter	437B or 438A	437B or 438A
Power sensor	8482A	8483A
High sensitivity power sensor	8481D opt H70	8481D opt H70
50 MHz reference attenuator	11708A (p/o 8481D)	11708A (p/o 8481D)
Minimum loss pad		11852B
30 MHz bandpass filter	9135-0475	9135-0475
75 ohm termination		00909-60019
Step Attenuator, 100 dB	8496A/G opt. 001, H17	8496A/G opt. 001, H17
Attenuator switch driver (optional)	11713A	11713A
HP-IB cables (3 or 4)	10833A	10833A
Type-N cables (2)	8120-4781	8120-4781
Adapter type-N(m)/type-N(m)	1250-1475	1250-1528
Adapter, BNC(m) to N(f)	1250-0077	1250-0077
Adapter, type-N (f)/type-N (f)	1250-1472	
Disk drive	9122C/D	9122C/D
ThinkJet Printer	2225A	2225A

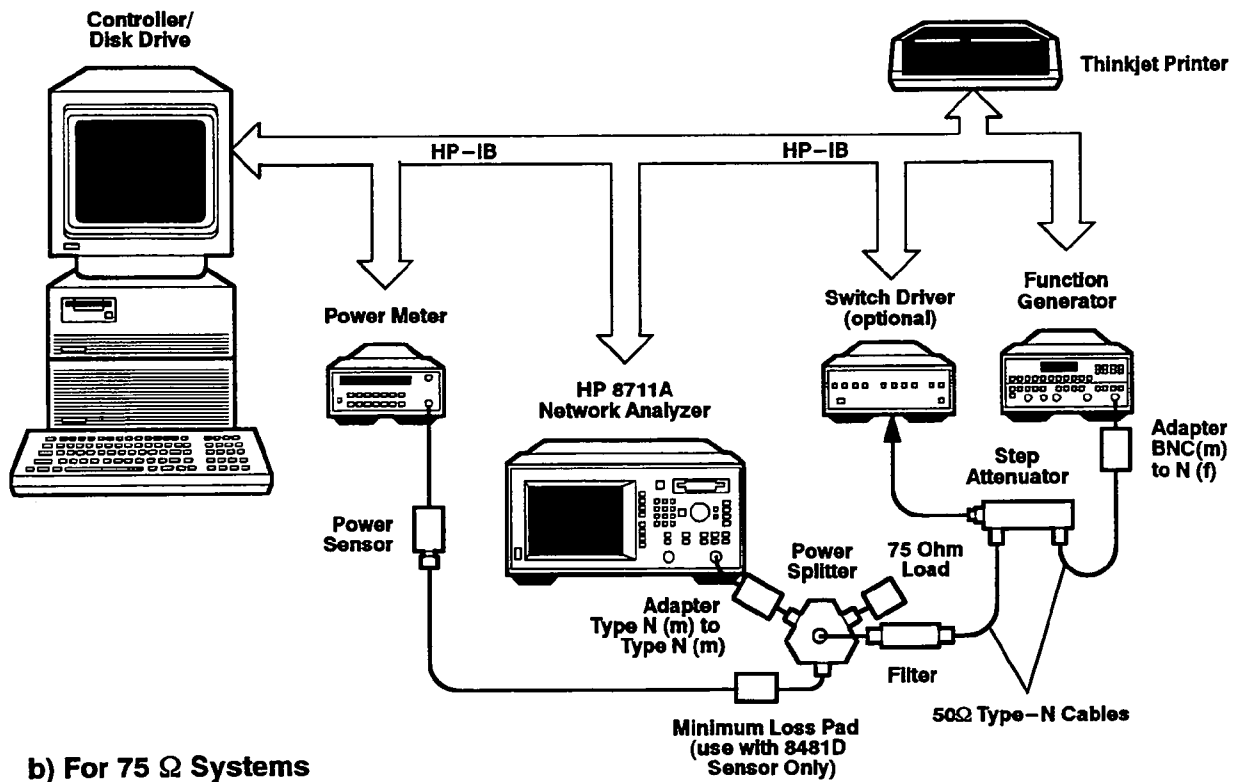
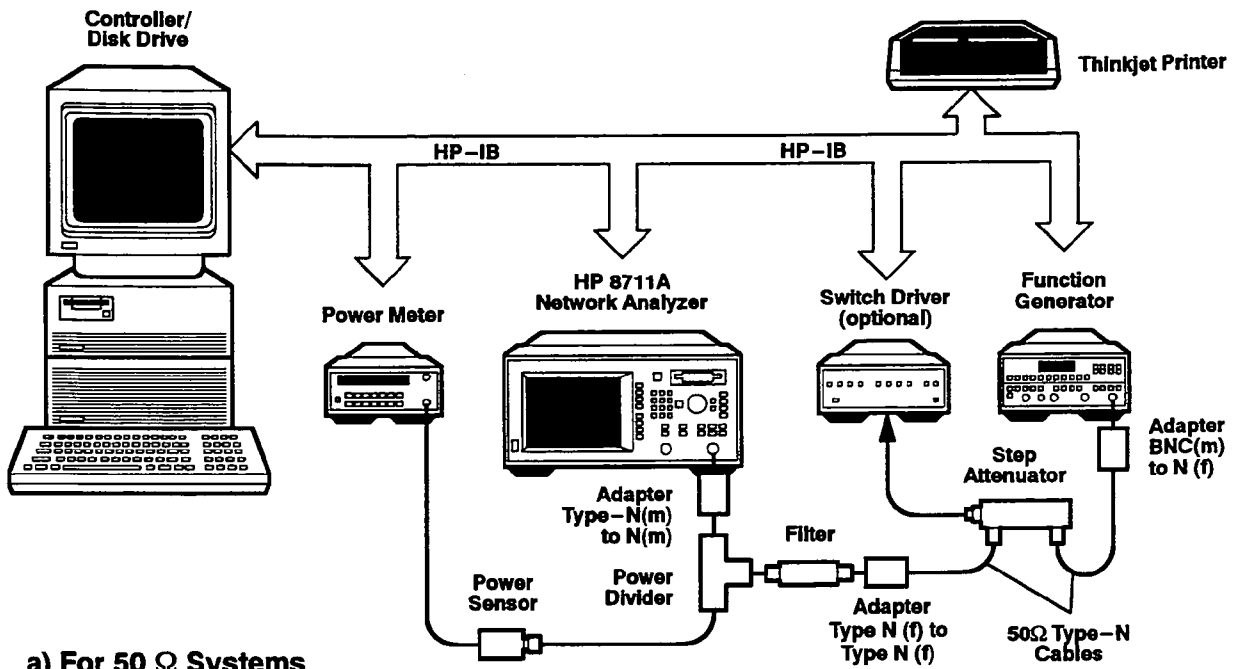

Figure 2-13. Setup for Absolute Power Accuracy

1. Connect the equipment in one of the configurations shown in Figure 2-13, depending on the impedance of the HP 8711 that you are testing. Do not connect the power sensor to the power divider or splitter yet, since the power meter will be calibrated during the procedure.
2. If you haven't already done so, load the test software by following the procedure in "Loading and Running the Test Software" located earlier in this chapter.
3. Select "Absolute Power Accuracy" from the performance tests main menu.
4. The program will ask for the cal factors at 30 MHz for each power sensor. Notice that these are NOT the reference cal factors for the sensors (which are at 50 MHz). You will be asked for these values later.
5. Follow the program's instructions to complete the test.

If the Analyzer Fails the Test

Since the absolute power accuracy is not a warranted specification, failures where the measured value exceeds the typical values by a small amount are acceptable. The performance may be improved by performing the "B* Amplitude Correction" (see the Adjustments section of this manual).

If the power accuracy is much worse than typical, and it cannot be adjusted, there may be a problem with the receiver. Refer to the Troubleshooting section of this manual.

2-8. SYSTEM DIRECTIVITY AND PORT MATCH AUTOMATED PERFORMANCE TEST

Directivity is a measure of a system's ability to separate the incident and reflected signals. You can examine directivity by measuring a calibration kit load. The load has a much better return loss than the system's receiver does, so any power detected from this measurement is assumed to be due to directivity error.

Port match indicates the impedance match of the test port. You can determine transmission port match by making a reflection measurement when a cable is connected between the reflection and transmission ports. You can determine source match at the reflection port from reflection measurements of an open, short, and load.

The HP 8711 specifications for system directivity and port match apply after you have done a reflection calibration. The performance of an error-corrected system depends primarily on the quality of the calibration standards, connector repeatability, system dynamic accuracy, and system noise and stability. Since error correction is a mathematical function, verifying the calibration kit and these system characteristics is sufficient to ensure that the corrected directivity and port match specifications are met. Note that the performance of the uncorrected hardware does not affect the accuracy of the corrected system, although it will affect the stability.

You should have your calibration kit(s) recertified at least once a year to verify that they still meet their specifications. System dynamic accuracy and noise floor are tested as part of the performance tests. No other test is required or provided to verify the user corrected directivity and port match.

The analyzer also has a default calibration available. This test checks the performance of the instrument with the default correction on. This is a non-warranted supplemental characteristic; it is not a specification.

System directivity typical characteristic:

30 dB (default correction)

Port match typical characteristics:

20 dB: Transmission Port

14 dB: Reflection Port

To set up the equipment

The list below shows the equipment used in this test. The HP 85032B (for 50 ohm analyzers) or the HP 85036B (for 75 ohm systems) must be used.

Warm-up time is 1 hour.

Equipment	Recommended Model or HP Part Number	
	50 Ohm (std.)	75 Ohm (opt. 1EC)
HP BASIC controller (with BASIC 5.0 or higher)	9000 series 200/300	9000 series 200/3000
Test software	08711-10009	08711-10009
Type-N calibration kits	85032B	85036B
Type-N test port cable	8120-4781	8120-2408
Disk drive	9122C/D	9122C/D
HP-IB cables (2)	10833A/B/C	10833A/B/C
ThinkJet Printer	2225A	2225A

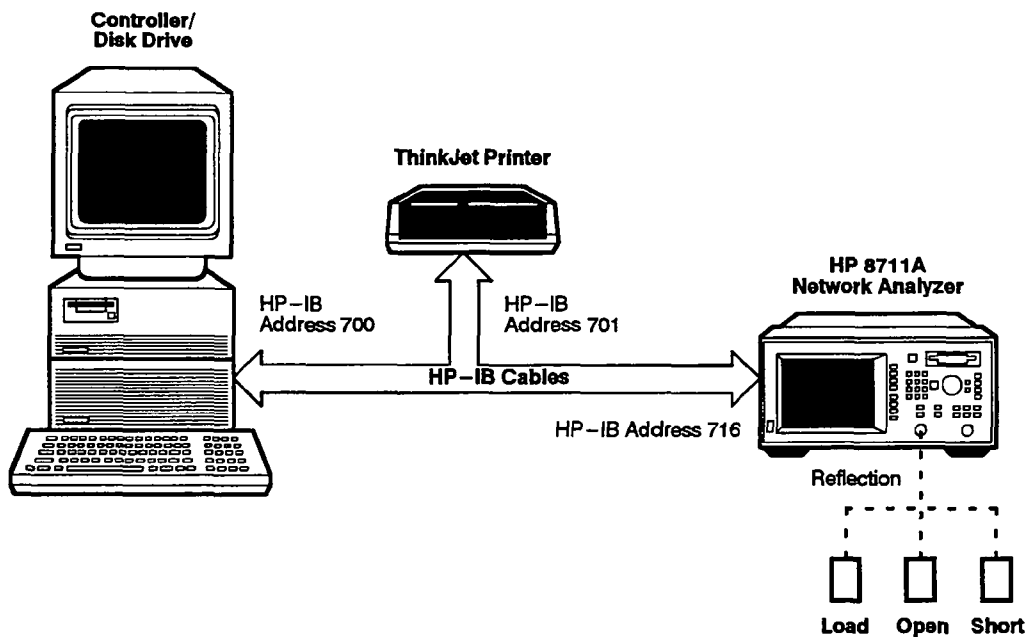

Figure 2-14. Setup for System Directivity Test

1. Set up the equipment as shown in Figure 2-14.
2. Load the test software by following the procedure in "Loading and Running the Test Software" located earlier in this chapter.
3. Select "Directivity and Port Match" from the performance tests main menu.
4. Make a reflection measurement calibration by following the prompts on the analyzer screen.
5. Connect the type-N cable to the REFLECTION port. Follow the prompts to perform another reflection calibration at the end of the cable, using the female cal kit devices.

- When prompted, connect the type-N cable between the REFLECTION and TRANSMISSION ports as shown in Figure 2-15.

The analyzer measures the transmission port match and then stores the test data to a disk.

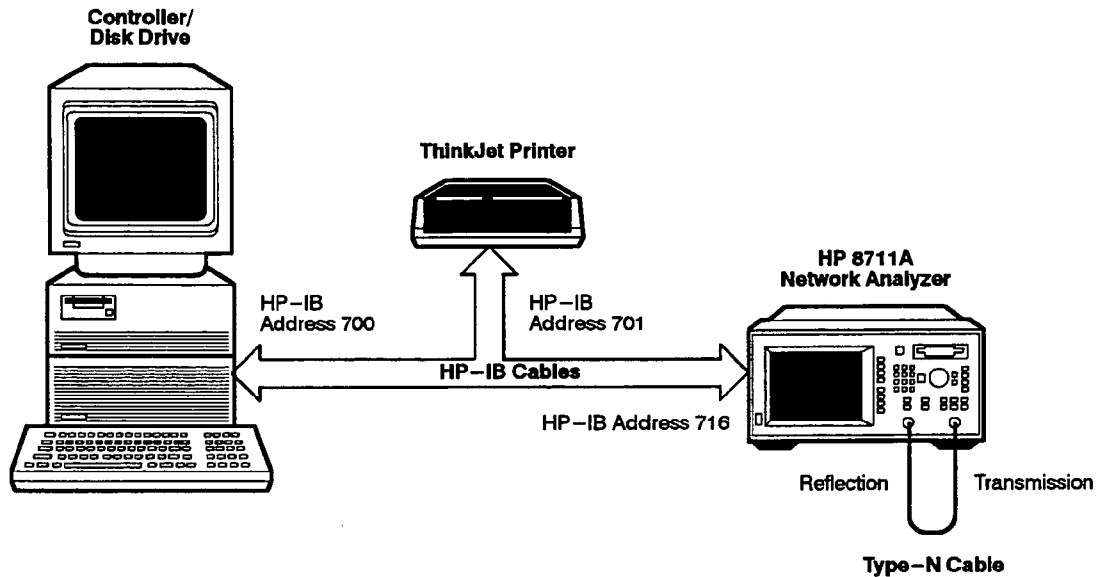

Figure 2-15. Setup for Measuring a Thru Cable

- To print the test results in a test record format, refer to the procedure in "Printing Performance Test Results" located earlier in this section.

If the Analyzer Fails the Test

If the analyzer fails the test, examine the connectors of the analyzer test ports, cables, and calibration kit devices. Directivity problems are most likely caused by a faulty default calibration, standard load device, test port connector, or receiver assembly.

Clean all the connectors and repeat the test.

Using a different calibration kit, perform the "Reflection Correction Adjustment" procedure in the "Adjustments" chapter. If you use the same calibration devices to do both the adjustment and this test, you will only be making a repeatability measurement.

CALCULATION WORKSHEET FOR 50Ω STANDARD INSTRUMENTS

**Figure 2–16. Dynamic Range: Compression Test
(Narrowband)**

Frequency	Attenuation Value (dB) (>0)	Input Level +10 dBm	
		Measured Value (dB)	Compression at + 10 dBm
300 kHz			
20 MHz			
400 MHz			
800 MHz			
1.0 GHz			
1.3 GHz			

**Figure 2–17. Power Range and Flatness Test
FOR 50Ω STANDARD**

Nominal Power	Measured Power at CW Frequencies						
	300 kHz	10 MHz	50 MHz	100 MHz	500 MHz	1 GHz	1.3 GHz
+16 dBm							Footnote 1
+7 dBm							
0 dBm							

1. Set power to +13 dBm for 1.3 GHz measurement.

**Figure 2–18. Power Range and Flatness Worst Case Values
FOR 50Ω STANDARD**

Nominal Power	Maximum Power (dBm)	Minimum Power (dBm)	Test Results Max-Min (dB)
+16 dBm			
+7 dBm			
0 dBm			

**Figure 2-19. Broadband Frequency Response
FOR 50Ω STANDARD**

Frequency (MHz)	First Setup		Second Setup		Frequency Response
	(a) Marker Value	(b) Power Meter Reading	(c) Marker Value	(d) Power Meter Reading	(e) $0.5(a-b+c-d)$
10					
50					
100					
300					
500					
700					
900					
1100					
1300					

CALCULATION WORKSHEET FOR 50Ω OPTION 1E1 INSTRUMENTS

**Figure 2–16. Dynamic Range: Compression Test
(Narrowband)**

Frequency	Attenuation Value (dB) (>0)	Input Level +10 dBm	
		Measured Value (dB)	Compression at + 10 dBm
300 kHz			
20 MHz			
400 MHz			
800 MHz			
1.0 GHz			
1.3 GHz			

**Figure 2–17. Power Range and Flatness Test
FOR 50Ω OPTION 1E1**

Nominal Power	Measured Power at CW Frequencies						
	300 kHz	10 MHz	50 MHz	100 MHz	500 MHz	1 GHz	1.3 GHz
+13 dBm							Footnote 1
+7 dBm							
0 dBm							
-20 ² dBm							
-60 ² dBm							

1. Set power to +10 dBm for 1.3 GHz measurement.
2. With an HP 8481D power sensor.

**Figure 2–18. Power Range and Flatness Worst Case Values
FOR 50Ω OPTION 1E1**

Nominal Power	Maximum Power (dBm)	Minimum Power (dBm)	Test Results Max–Min (dB)
+13 dBm			
+7 dBm			
0 dBm			
-20 dBm			
-60 dBm			

Figure 2–19. Broadband Frequency Response
FOR 50Ω OPTION 1E1

Frequency (MHz)	First Setup		Second Setup		Frequency Response
	(a) Marker Value	(b) Power Meter Reading	(c) Marker Value	(d) Power Meter Reading	(e) $0.5(a-b+c-d)$
10					
50					
100					
300					
500					
700					
900					
1100					
1300					

CALCULATION WORKSHEET FOR 75Ω STANDARD INSTRUMENTS

**Figure 2–16. Dynamic Range: Compression Test
(Narrowband)**

Frequency	Attenuation Value (dB) (>0)	Input Level +7 dBm	
		Measured Value (dB)	Compression at + 7 dBm
300 kHz			
20 MHz			
400 MHz			
800 MHz			
1.0 GHz			
1.3 GHz			

**Figure 2–17. Power Range and Flatness Test
FOR 75Ω STANDARD**

Nominal Power	Measured Power at CW Frequencies						
	300 kHz	10 MHz	50 MHz	100 MHz	500 MHz	1 GHz	1.3 GHz
+13 dBm							Footnote 1
+6 dBm							
0 dBm							

1. Set power to +10 dBm for 1.3 GHz measurement

**Figure 2–18. Power Range and Flatness Worst Case Values
FOR 75Ω STANDARD**

Nominal Power	Maximum Power (dBm)	Minimum Power (dBm)	Test Results Max–Min (dB)
+13 dBm			
+6 dBm			
0 dBm			

**Figure 2–19. Broadband Frequency Response
FOR 75Ω STANDARD**

Frequency (MHz)	First Setup		Second Setup		Frequency Response
	(a) Marker Value	(b) Power Meter Reading	(c) Marker Value	(d) Power Meter Reading	(e) 0.5(a-b+c-d)
10					
50					
100					
300					
500					
700					
900					
1100					
1300					

CALCULATION WORKSHEET FOR 75Ω OPTION 1E1 INSTRUMENTS

**Figure 2–16. Dynamic Range: Compression Test
(Narrowband)**

Frequency	Attenuation Value (dB) (>0)	Input Level +7 dBm	
		Measured Value (dB)	Compression at +7 dBm
300 kHz			
20 MHz			
400 MHz			
800 MHz			
1.0 GHz			

**Figure 2–17. Power Range and Flatness Test
FOR 75Ω OPTION 1E1**

Nominal Power	Measured Power at CW Frequencies						
	300 kHz	10 MHz	50 MHz	100 MHz	500 MHz	1 GHz	1.3 GHz
+10 dBm							Footnote 1
+6 dBm							
0 dBm							
–20 ² dBm							
–20 ³ dBm							
11852B Loss							
–60 ⁴ dBm							
–60 ⁵ dBm							

1. Set power to +7 dBm for 1.3 GHz measurement
2. HP 8483A sensor reading.
3. HP 8481D power sensor reading.
4. HP 8481D power sensor reading.
5. HP 8481D power sensor reading. Corrected for HP 11852B loss.

**Figure 2–18. Power Range and Flatness Worst Case Values
FOR 75Ω OPTION 1E1**

Nominal Power	Maximum Power (dBm)	Minimum Power (dBm)	Test Results Max-Min (dB)
+10 dBm			
+6 dBm			
0 dBm			
-20 dBm			
-60 dBm			

**Figure 2–19. Broadband Frequency Response
FOR 75Ω OPTION 1E1**

Frequency (MHz)	First Setup		Second Setup		Frequency Response
	(a) Marker Value	(b) Power Meter Reading	(c) Marker Value	(d) Power Meter Reading	(e) $0.5(a-b+c-d)$
10					
50					
100					
300					
500					
700					
900					
1100					
1300					

HP 8711A Test Record (1 of 4)

Test Facility _____	Report Number _____
_____	Date _____
_____	Customer _____
_____	Tested by _____
Model _____	Ambient temperature _____ °C
Serial Number _____	Relative humidity _____ %
Options _____	Line frequency _____ Hz (nominal)
Calibration Constants Revision _____	
Special Notes	

HP 8711A Test Record (2 of 4)

Model _____	Report Number _____	Date _____
Test Equipment Used	Model Number	Trace Number
Cal Due Date		
1. _____	_____	_____
2. _____	_____	_____
3. _____	_____	_____
4. _____	_____	_____
5. _____	_____	_____
6. _____	_____	_____
7. _____	_____	_____
8. _____	_____	_____

50Ω STANDARD
HP 8711A Test Record (3 of 4)

Serial Number:		Report Number:			Date:
Test No.	Test Description	Minimum Specification	Measured Results	Maximum Specification	Measurement Uncertainty ¹
2-1.	Frequency Range and Accuracy				
	Frequencies				
	300 kHz	299.9985 kHz		300.0015 kHz	±0.0015 kHz
	1 MHz	0.999995 MHz		1.000005 MHz	±0.000002 MHz
	5 MHz	4.999975 MHz		5.000025 MHz	±0.000007 MHz
	10 MHz	9.999950 MHz		10.000050 MHz	±0.000011 MHz
	50 MHz	49.99975 MHz		50.00025 MHz	±0.000064 MHz
	100 MHz	99.99950 MHz		100.0005 MHz	±0.000127 MHz
	500 MHz	499.9975 MHz		500.0025 MHz	±0.000632 MHz
	1000 MHz	999.9950 MHz		1000.0050 MHz	±0.001260 MHz
	1300 MHz	1299.9935 MHz		1300.0065 MHz	±0.001586 MHz
2-2.	Dynamic Range				
	Compression				
	+10 dBm			0.8 dB	±0.26 dB
	Noise Floor				
	Narrowband Mode:				
300 kHz to 5 MHz			-50 dBm	±0.10 dB	
5 MHz to 1.3 GHz			-80 dBm	±0.80 dB	
Broadband Mode:					
10 MHz to 1.3 GHz			-50 dBm	±2.00 dB	

1. Using the equipment and procedures documented in this manual. Assumes 20 dB attenuator used in compression test had data measured on an HP 8753 system with full 2-port calibration.

50Ω STANDARD
HP 8711A Test Record (4 of 4)

Serial Number:		Report Number:			Date:
Test No.	Test Description	Minimum Specification	Measured Results	Maximum Specification	Measurement Uncertainty ¹
2-3.	Power Range and Flatness				
	Power = +16 dBm max. _____ min. _____			2.0 dB	±0.11 dB
	Power = +7.0 dBm max. _____ min. _____			2.0 dB	±0.11 dB
	Power = 0 dBm max. _____ min. _____			2.0 dB	±0.11 dB
	Power Hole Check				
	Power = +13 dBm		Pass/Fail	2.0 dB	±0.12 dB
	Power = 0 dBm		Pass/Fail	2.0 dB	±0.11 dB
2-4.	Broadband Frequency Response (Typical Response)				
	Maximum value			+0.5 dB	±0.11 dB
	Minimum value	-0.5 dB			±0.11 dB

1. Using the equipment and procedures documented in this manual. Assumes 20 dB attenuator used in compression test had data measured on an HP 8753 system with full 2-port calibration.

**50Ω OPTION 1E1
HP 8711A Test Record (3 of 4)**

Serial Number:		Report Number:			Date:
Test No.	Test Description	Minimum Specification	Measured Results	Maximum Specification	Measurement Uncertainty ¹
2-1.	Frequency Range and Accuracy				
	Frequencies				
	300 kHz	299.9985 kHz		300.0015 kHz	±0.0015 kHz
	1 MHz	0.999995 MHz		1.000005 MHz	±0.000002 MHz
	5 MHz	4.999975 MHz		5.000025 MHz	±0.000007 MHz
	10 MHz	9.999950 MHz		10.000050 MHz	±0.000011 MHz
	50 MHz	49.99975 MHz		50.00025 MHz	±0.000064 MHz
	100 MHz	99.99950 MHz		100.0005 MHz	±0.000127 MHz
	500 MHz	499.9975 MHz		500.0025 MHz	±0.000632 MHz
	1000 MHz	999.9950 MHz		1000.0050 MHz	±0.001260 MHz
	1300 MHz	1299.9935 MHz		1300.0065 MHz	±0.001586 MHz
2-2.	Dynamic Range				
	Compression				
	+10 dBm			0.8 dB	±0.26 dB
	Noise Floor				
	Narrowband Mode:				
	300 kHz to 5 MHz			-50 dBm	±0.10 dB
	5 MHz to 1.3 GHz			-80 dBm	±0.80 dB
	Broadband Mode:				
	10 MHz to 1.3 GHz			-50 dBm	±2.00 dB

1. Using the equipment and procedures documented in this manual. Assumes 20 dB attenuator used in compression test had data measured on an HP 8753 system with full 2-port calibration.

**50Ω OPTION 1E1
HP 8711A Test Record (4 of 4)**

Serial Number:		Report Number:			Date:
Test No.	Test Description	Minimum Specification	Measured Results	Maximum Specification	Measurement Uncertainty ¹
2-3.	Power Range and Flatness				
	Power = +13 dBm max. _____ min. _____		_____	4.0 dB	±0.12 dB
	Power = +7.0 dBm max. _____ min. _____		_____	4.0 dB	±0.11 dB
	Power = 0 dBm max. _____ min. _____		_____	4.0 dB	±0.11 dB
	Power = -20 dBm max. _____ min. _____		_____	4.0 dB	±0.12 dB
	Power = -60 dBm max. _____ min. _____		_____	4.0 dB	±0.13 dB
	Power Hole Check				
	Power = +10 dBm		Pass/Fail	4.0 dB	±0.11 dB
	Power = -60 dBm		Pass/Fail	4.0 dB	±0.13 dB
2-4.	Broadband Frequency Response (Typical Response)				
	Maximum value		_____	+0.5 dB	±0.11 dB
	Minimum value	-0.5 dB	_____		±0.11 dB

1. Using the equipment and procedures documented in this manual. Assumes 20 dB attenuator used in compression test had data measured on an HP 8753 system with full 2-port calibration.

75Ω STANDARD
HP 8711A Test Record (3 of 4)

Serial Number:		Report Number:			Date:
Test No.	Test Description	Minimum Specification	Measured Results	Maximum Specification	Measurement Uncertainty ¹
2-1.	Frequency Range and Accuracy				
	Frequencies				
	300 kHz	299.9985 kHz	_____	300.0015 kHz	±0.0015 kHz
	1 MHz	0.999995 MHz	_____	1.000005 MHz	±0.000002 MHz
	5 MHz	4.999975 MHz	_____	5.000025 MHz	±0.000007 MHz
	10 MHz	9.999950 MHz	_____	10.000050 MHz	±0.000011 MHz
	50 MHz	49.99975 MHz	_____	50.00025 MHz	±0.000064 MHz
	100 MHz	99.99950 MHz	_____	100.0005 MHz	±0.000127 MHz
	500 MHz	499.9975 MHz	_____	500.0025 MHz	±0.000632 MHz
	1000 MHz	999.9950 MHz	_____	1000.0050 MHz	±0.001260 MHz
	1300 MHz	1299.9935 MHz	_____	1300.0065 MHz	±0.001586 MHz
2-2.	Dynamic Range				
	Compression				
	+7 dBm		_____	0.8 dB	±0.24 dB
	Noise Floor				
	Narrowband Mode:				
	300 kHz to 5 MHz		_____	-47 dBm	±0.10 dB
	5 MHz to 1.3 GHz		_____	-77 dBm	±0.57 dB
	Broadband Mode:				
	10 MHz to 1.3 GHz		_____	-47 dBm	±1.70 dB

1. Using the equipment and procedures documented in this manual. Assumes 20 dB attenuator used in compression test had data measured on an HP 8753 system with full 2-port calibration.

75Ω STANDARD
HP 8711A Test Record (4 of 4)

Serial Number:		Report Number:			Date:
Test No.	Test Description	Minimum Specification	Measured Results	Maximum Specification	Measurement Uncertainty ¹
2-3.	Power Range and Flatness Power = +13 dBm max. _____ min. _____ Power = +6.0 dBm max. _____ min. _____ Power = 0 dBm max. _____ min. _____ Power Hole Check Power = +10 dBm Power = 0 dBm		_____ _____ _____ Pass/Fail Pass/Fail	3.0 dB 3.0 dB 3.0 dB 3.0 dB 3.0 dB 3.0 dB	±0.21 dB ±0.21 dB ±0.21 dB ±0.21 dB ±0.21 dB ±0.21 dB
2-4.	Broadband Frequency Response (Typical Response) Maximum value Minimum value	_____ -0.5 dB	_____ _____	+0.5 dB _____	±0.11 dB ±0.11 dB

1. Using the equipment and procedures documented in this manual. Assumes 20 dB attenuator used in compression test had data measured on an HP 8753 system with full 2-port calibration.

75Ω OPTION 1E1
HP 8711A Test Record (3 of 4)

Serial Number:		Report Number:			Date:
Test No.	Test Description	Minimum Specification	Measured Results	Maximum Specification	Measurement Uncertainty ¹
2-1.	Frequency Range and Accuracy				
	Frequencies				
	300 kHz	299.9985 kHz		300.0015 kHz	±0.0015 kHz
	1 MHz	0.999995 MHz		1.000005 MHz	±0.000002 MHz
	5 MHz	4.999975 MHz		5.000025 MHz	±0.000007 MHz
	10 MHz	9.999950 MHz		10.000050 MHz	±0.000011 MHz
	50 MHz	49.99975 MHz		50.00025 MHz	±0.000064 MHz
	100 MHz	99.99950 MHz		100.0005 MHz	±0.000127 MHz
	500 MHz	499.9975 MHz		500.0025 MHz	±0.000632 MHz
	1000 MHz	999.9950 MHz		1000.0050 MHz	±0.001260 MHz
	1300 MHz	1299.9935 MHz		1300.0065 MHz	±0.001586 MHz
2-2.	Dynamic Range				
	Compression				
	At +7 dBm			0.8 dB	±0.24 dB
	Noise Floor				
	Narrowband Mode:				
	300 kHz to 5 MHz			-47 dBm	±0.10 dB
	5 MHz to 1.3 GHz			-77 dBm	±0.57 dB
	Broadband Mode:				
	10 MHz to 1.3 GHz			-47 dBm	±1.70 dB

1. Using the equipment and procedures documented in this manual. Assumes 20 dB attenuator used in compression test had data measured on an HP 8753 system with full 2-port calibration.

**75Ω OPTION 1E1
Test Record (4 of 4)**

Serial Number:		Report Number:			Date:
Test No.	Test Description	Minimum Specification	Measured Results	Maximum Specification	Measurement Uncertainty ¹
2-3.	Power Range and Flatness				
	Power = +10 dBm max. _____ min. _____		_____	4.0 dB	±0.21 dB
	Power = +6.0 dBm max. _____ min. _____		_____	4.0 dB	±0.21 dB
	Power = 0 dBm max. _____ min. _____		_____	4.0 dB	±0.21 dB
	Power = -20 dBm max. _____ min. _____		_____	4.0 dB	±0.21 dB
	Power = -60 dBm max. _____ min. _____		_____	4.0 dB	±0.12 dB
	Power Hole Check				
	Power = +7 dBm		Pass/Fail	4.0 dB	±0.21 dB
	Power = -60 dBm		Pass/Fail	4.0 dB	±0.12 dB
2-4.	Broadband Frequency Response (Typical Response)				
	Maximum value		_____	+0.5 dB	±0.11 dB
	Minimum value	-0.5 dB	_____		±0.11 dB

1. Using the equipment and procedures documented in this manual. Assumes 20 dB attenuator used in compression test had data measured on an HP 8753 system with full 2-port calibration.

Adjustments

This chapter contains procedures that show you how to adjust the HP 8711. You need an external controller for running three of the adjustments, but the remaining adjustments are accessed through the analyzer's service menus.

Refer to "Post-Repair Procedures" in the "Replaceable Parts" chapter to determine what adjustment procedures you need to do when a particular part has been replaced.

You should perform the adjustment procedures in the order given.

Adjustment Description

- Fractional-N VCO Adjustment
- Fractional-N Spur Adjustment (Requires controller)
- Frequency Accuracy Adjustment
- Serial Number (Requires controller)
- LO Power Correction
- Switched Gain Correction
- External Detector Correction
- Aux Input Correction
- Source Power (ALC) Correction
- B Amplitude Correction
- Transmission (B/R) Correction
- Reflection (One Port) Correction
- R* Amplitude Correction
- R* Frequency Response Correction
- B* Amplitude Correction (Requires controller)
- Storing and Recalling Correction Constants

Firmware Adjustments

When you switch on the analyzer power, the HP 8711 copies the current correction constants from the CPU EPROM into a RAM buffer. When you run adjustment tests, the analyzer generates correction constants and saves them to the RAM buffer only (they are erased if the power is switched off). To transfer the newly generated correction constants from the RAM to the EPROM, perform the "Storing and Recalling Correction Constants" procedure in this chapter.

You can also use the procedure in "Storing and Recalling Correction Constants" to make a copy of the correction constants, so you can quickly restore the adjustment data if you replace the CPU board or update firmware.

When you are performing the adjustment procedures, you should store the correction constants to a disk file periodically. This allows you to restore data quickly in case you need to switch off the analyzer power before completing the adjustments.

FRACTIONAL-N VCO ADJUSTMENT

This procedure shows you how to adjust the frequency of the fractional-N VCO on the A3 frac-N/reference assembly.

Caution



Place the analyzer on an anti-static mat and wear a connecting wrist strap when making this adjustment.

Equipment	Recommended Model or Part Number	
	50 ohm (std)	75 ohm (opt. 1EC)
Service extender board	part of service kit, 08711-60010	part of service kit, 08711-60010
Digital voltmeter	any	any

1. Switch off the instrument power. Remove the front panel by following these steps and referring to Figure 3-1:
 - a. Remove the trim strip from the handles.
 - b. Remove the four #10 torx screws attaching each handle to the instrument.
 - c. Pull the analyzer toward you to extend about two inches over the table top.
 - d. Grasp and pull the front panel with two hands: one on the top-middle of the panel, and the other on the bottom-middle of the panel. Disconnect the front panel ribbon cable.
 - e. Remove the two #15 torx screws attaching the handle plate on the right side.

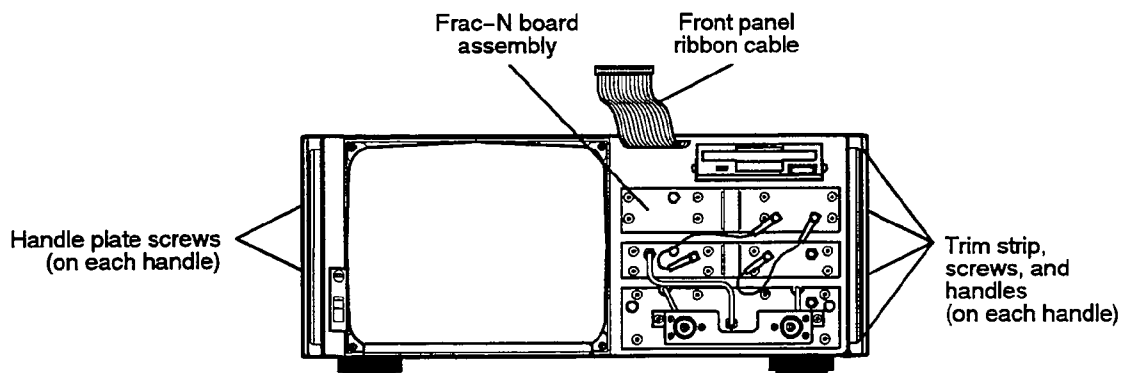

Figure 3-1. Removing the Handles and Front Panel

2. To setup the service extender board for adjusting the frac-N board, follow these steps:
 - a. Remove the backplane cover from the rear panel of the analyzer by lifting up on the tab and sliding the cover toward the power cord receptacle.
 - b. Attach the service extender board by reversing step (a) with the lower extender board assembly.
 - c. Place an antistatic mat on top of the analyzer.
 - d. Remove the two SMB cables from the frac-N/reference assembly. Remove the nut on the rear panel EXT REF BNC connector.
 - e. Use the handle to pull the board assembly out of the analyzer. Attach the frac-N/reference assembly backplane connector to the upper extender board.
 - f. Reconnect the SMB cables.
3. Switch on the analyzer power. Press **PRESET** **FREQ** **CW** **1.3** **GHz**.
4. Measure the voltage at TP11 on the frac-N board (see Figure 3-2 for the location).

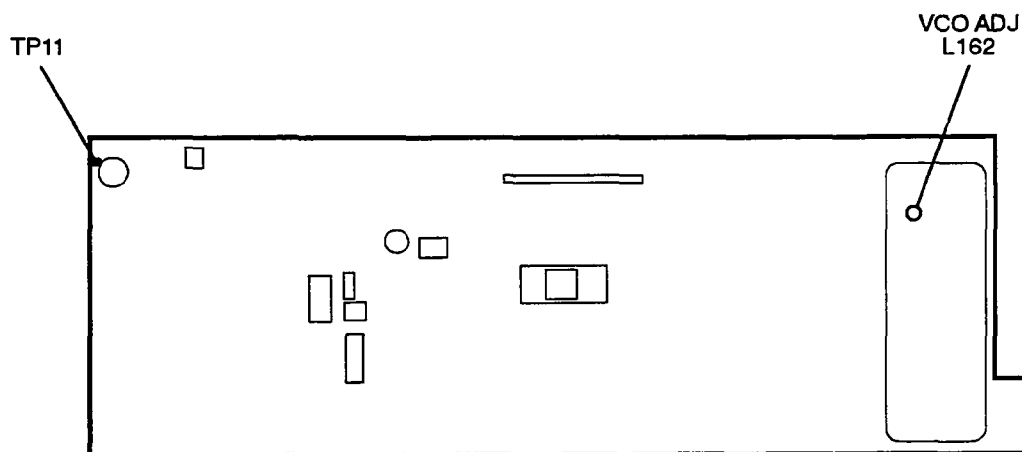

Figure 3-2. TP11 and L162 for Frac-N VCO Adjustment

5. Use a nonconductive tool to adjust L162 (see Figure 3-2) until TP11 reads -1.17 ± 0.03 volts. Remove the adjustment tool and check that the voltage doesn't change.
6. If you ARE going to make the frac-N spur adjustment, continue to that procedure without changing the equipment setup. If you ARE NOT going to make the frac-N spur adjustment, reassemble the analyzer.

3-4 Adjustments

FRACTIONAL-N SPUR ADJUSTMENT

This adjustment minimizes the spurs caused by the analog phase interpolators (APIs) on the frac-N board. An external controller sets the source output frequencies on the HP 8711 and sets up the spectrum analyzer to measure the spur. Then you adjust potentiometers to minimize the spur.

Equipment	Recommended Model or Part Number	
	50 ohm (std)	75 ohm (opt. 1EC)
HP BASIC controller w/BASIC 5.0 or higher	HP 9000 series 200/300	HP 9000 series 200/300
Test software	08711-10009	08711-10009
Spectrum Analyzer	8566B	8566B
Test port cable	8120-4781	8120-4781
Minimum loss pad		11852B
Service extender board	p/o service kit, 08711-60010	p/o service kit, 08711-60010

Note Before performing this adjustment



Check the voltage at A3TP11 as described in the previous adjustment (“fractional-N VCO adjustment, steps 3 through 5) and adjust as required.

1. If you already have the frac-N board assembly out of the analyzer and attached to the service board extender, continue with step 4. If not, continue with the next step.
2. Switch off the instrument power. Remove the front panel by following these steps and referring to Figure 3-3:
 - a. Remove the trim strip from the handles.
 - b. Remove the four #10 torx screws attaching each handle to the instrument.
 - c. Pull the analyzer toward you to extend about two inches over the table-top.
 - d. Grasp and pull the front panel with two hands: one on the top-middle of the panel, and the other on the bottom-middle of the panel. Disconnect the front panel ribbon cable.
 - e. Remove the two #15 torx screws attaching the handle plate on the right side.

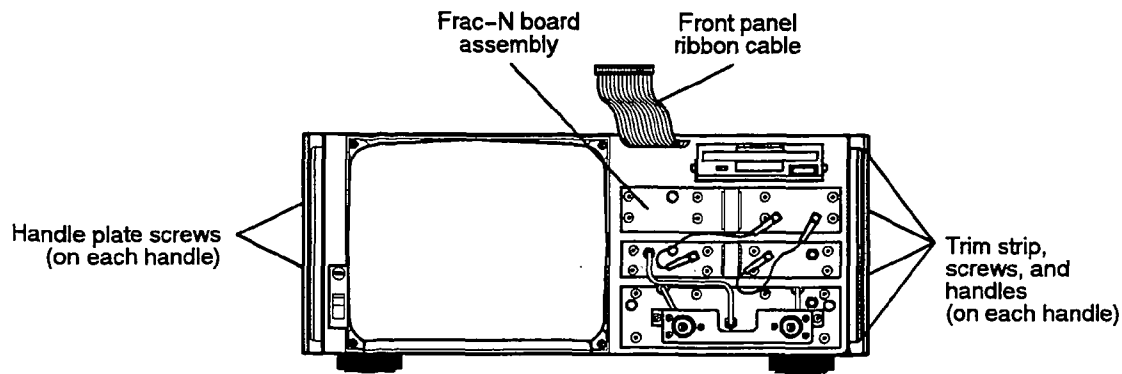

Figure 3-3. Removing the Handles and Front Panel

3. To setup the service extender board for adjusting the frac-N board, follow these steps:
 - a. Remove the backplane cover from the rear panel of the analyzer by lifting up on the tab and sliding the cover toward the power cord receptacle.
 - b. Attach the service extender board by reversing step (a) with the lower extender board.
 - c. Place an antistatic mat on top of the analyzer.
 - d. Remove the two SMB cables from the frac-N/reference assembly. Remove the nut on the rear panel EXT REF BNC connector.
 - e. Use the handle to pull the board assembly out of the analyzer. Attach the frac-N/reference assembly backplane connector to the upper extender board.
 - f. Reconnect the SMB cables.
4. Connect the equipment as shown in Figure 3-4.

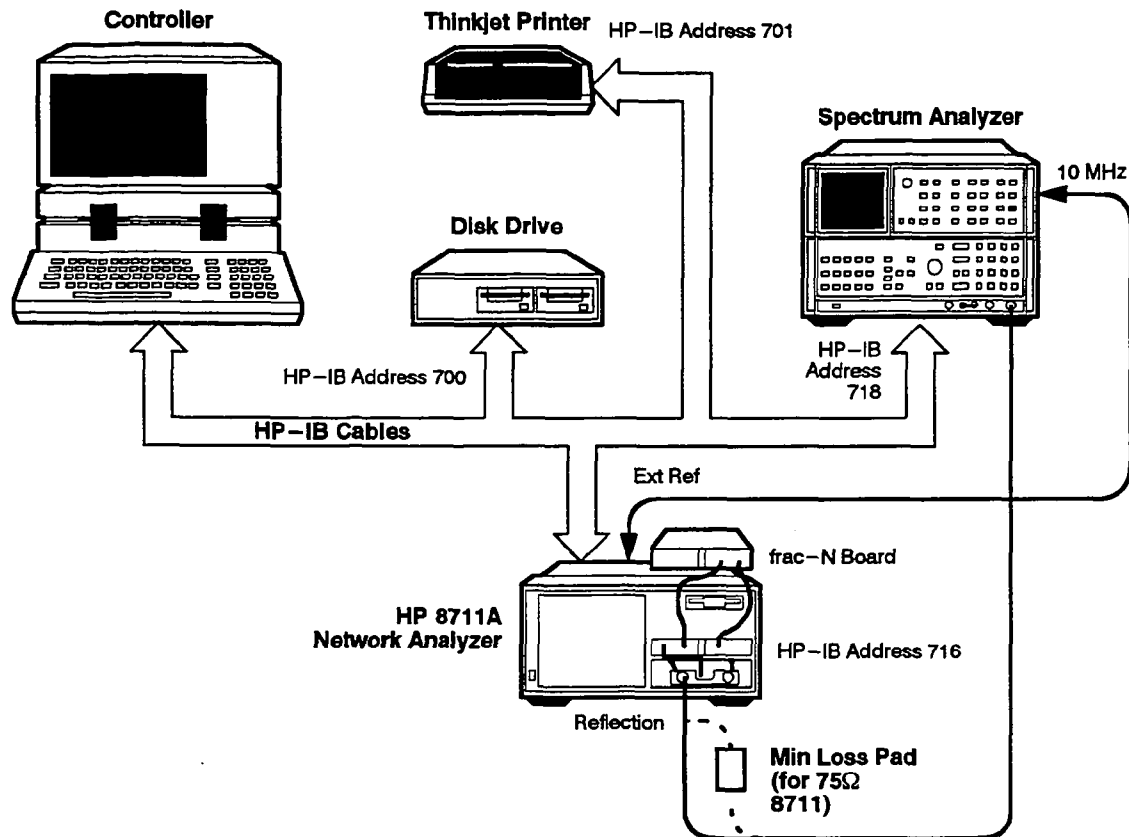

Figure 3-4. Setup for Frac-N Spur Adjustments

5. Load and run the test software by following the procedure in “Loading and Running the Test Software” in the “Performance Tests” chapter of this manual.
6. Select “Fractional-N Adjustments” from the performance tests main menu.
7. The program asks if you want to use the default test frequencies.
 - If you reply “Y”, the program tests the fractional-N VCO frequencies of 37 MHz, 45 MHz, and 56 MHz. This is suitable in most cases.
 - If you reply “N”, you can enter any three frequencies between 30 MHz and 60 MHz. This allows you to test specific frequencies where you may have found problems during the spurious signals adjustment.
8. For each API adjustment, the program shows spurs three times, once for each frac-N VCO frequency. To minimize the spur, adjust the potentiometer shown in Figure 3-5.

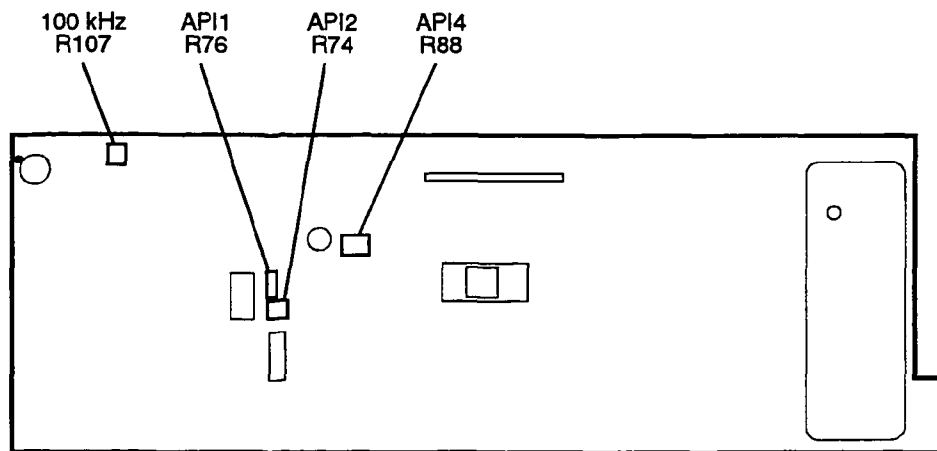

Figure 3-5. API and 100 kHz Adjustments

9. After the API adjustment, the program prompts you to adjust for the 100 kHz spur at a single frequency. The controller displays a message, telling you the adjustment is completed.
10. Insert the frac-N board back into the analyzer (don't reassemble the instrument completely yet). Run the API and 100 kHz spurs test (part of the Spurious Signal performance test). The spur performance of the fractional-N board may change significantly when you reinstall the assembly in the analyzer. If the performance deteriorates significantly, you may wish to repeat the adjustment.
11. If you do not need to repeat the API and 100 kHz spurs adjustment, remove the extender board and reassemble the instrument.

FREQUENCY ACCURACY ADJUSTMENT

In this procedure you adjust the frequency accuracy of the analyzer's source by adjusting the 10 MHz internal reference clock.

Equipment	Recommended Model or Part Number	
	50 ohm (std)	75 ohm (opt. 1EC)
Frequency counter	5342A	5342A
BNC cable	8120-1839	8120-1839
Minimum loss pad		11852B
Adapter, type-N(m) to BNC(f)	1250-0780	1250-0780

1. Connect the equipment as shown in Figure 3-6.

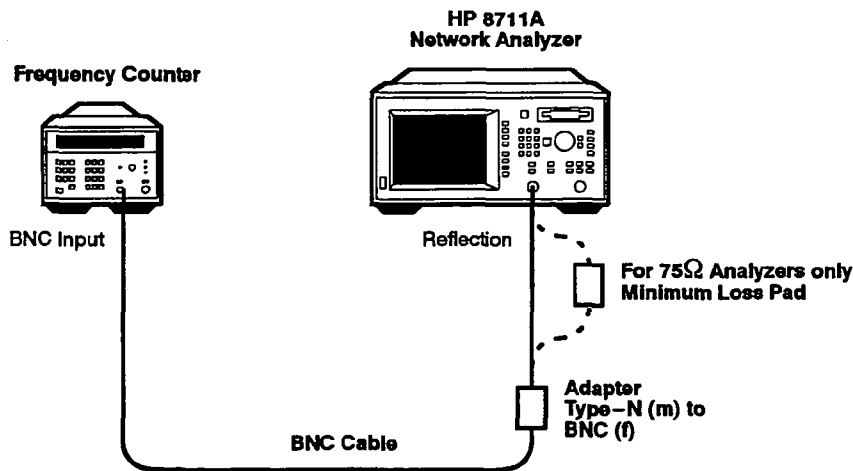

Figure 3-6. Setup for Frequency Accuracy Adjustment

2. Set the frequency counter input switches to the "10 Hz - 500 MHz" and 50 ohm positions.
3. On the analyzer, press **PRESET** **FREQ** **CW** **500** **MHZ**. If the frequency counter reading is 500 MHz \pm 2500 Hz, you do not need to make this adjustment. However, you can still make this adjustment to improve the frequency accuracy.
4. To proceed with the adjustment, disconnect the frequency counter and adapter(s) from the RF OUT connector.

5. Remove the handles and front panel by following these steps and referring to Figure 3-7.
 - a. Remove the trim strip from the handles.
 - b. Remove the screws attaching each handle to the instrument.
 - c. Pull the analyzer toward you to extend about two inches over the table-top.
 - d. Grasp and pull the front panel with two hands: one on the top-middle of the panel, and the other on the bottom-middle of the panel. Disconnect the front panel ribbon cable.

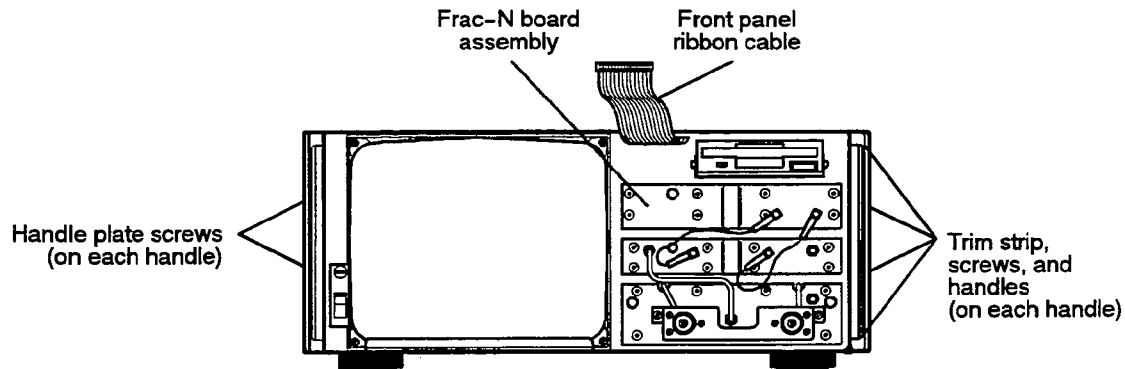

Figure 3-7. Removing the Handles and Front Panel

6. Reconnect the frequency counter and adapter(s) to the RF OUT connector.
7. To obtain a counter reading of $500 \text{ MHz} \pm 2500 \text{ Hz}$ or better, adjust R1 on the frac-N/reference assembly (accessible through a hole in shield between J1 and J3).
8. Reassemble the analyzer.

SET SERIAL NUMBER ADJUSTMENT

This procedure shows you how to store the analyzer's serial number in the CPU EPROM. You should perform this procedure whenever you replace the CPU board.

You can only perform this procedure over HP-IB, so an HP BASIC controller (either external or IBASIC) is required.

Note



Where XXXXXXXXXXXX appears below, replace those characters with the serial number of your analyzer but maintain the leading and following apostrophes (both are ASCII character 39). For example, if the serial number of your analyzer is 1234A56789, the HP BASIC line of code would be

```
OUPUT 716;"DIAG:SNUM '1234A56789' "
```

1. Write down the 10-character serial number, exactly as shown on the analyzer rear panel label.
2. Use one of the following BASIC commands to set the serial number. Replace the XXXXXXXXXXXX in the command with your analyzer's serial number.

- If you are using HP BASIC from an external controller, enter:

```
OUTPUT 716;"DIAG:SNUM 'XXXXXXXXXXXX'" (and press ENTER)
```

On the analyzer, press **Return to Local**.

This assumes that the HP 8711 is at address of 16 and the HP-IB is at 7. If not, either use the analyzer's actual address, or change the analyzer's address to 16.

- If you are using IBASIC:

Press **[SYSTEM OPTIONS]** **IBASIC** **Edit** **Insert Line**.

If you have a DIN keyboard, enter the following:

```
10 OUTPUT 800;"DIAG:SNUM 'XXXXXXXXXXXX'" (and press ENTER)
```

```
20 END (and press ENTER)
```

If you don't have a DIN keyboard, use the front panel knob and **Select Character** key to point and select each character of the commands above.

Press **Prior Menu** **Prior Menu** **Run**.

3. Press **[SYSTEM OPTIONS]** **Service** **Instrument Info** to verify that you correctly installed the serial number.

The serial number is displayed in the dialogue box.

In Case of Difficulty

If the analyzer displays an error message that tells you the serial number has the wrong format, check the rear panel serial number tag again and verify that you have the correct serial number.

If the analyzer displays an error message that tells you “Serial number already set,” that means a serial number is already installed on that CPU board. Contact your nearest HP service center for instructions.

LO POWER CORRECTION ADJUSTMENT

This procedure shows you how to set the DAC (digital to analog converter) that controls the LO power level. By setting the LO power, you are optimizing the mixer performance for spurs versus stability (minimal drift).

The analyzer measures the narrowband B input at a CW frequency of 1.0 GHz with the LO power DAC at its maximum value. Then you reduce the DAC value until the trace level drops 0.2 dB.

If you press the **Prior Menu** key during this adjustment, the analyzer will abort the test.

Equipment	Recommended HP Part Number	
	50 ohm (std)	75 ohm (opt. 1EC)
Type-N cable	8120-4781	8120-2408

1. Connect a cable from the REFLECTION port to the TRANSMISSION port.

2. Press **PRESET** **SYSTEM OPTIONS** **Service** **Test and Adjustments** **Select Adjustment** **101** **ENTER** **Execute Test**.

The analyzer autoscales the display to 0.1 dB/division. It's normal for the trace to show some noise (up to 1 division peak-to-peak).

At the start of the adjustment test, the analyzer checks that the nominal power level is correct. If the power is not correct, the analyzer aborts the test and displays a "FAILED" message. This failure is usually caused by a faulty through cable.

3. Use the down arrow key or the front panel knob to decrease the DAC value until the trace level drops about 0.2 dB (2 divisions). Typically this will be at DAC values below 50.

If the trace level drops less than 0.2 dB at one DAC value, but more than 0.2 dB at the next DAC value, choose the higher DAC number.

4. Press **Done with Adjustment**. The 8711 presets when the test is done.

5. If you are NOT going to make any more adjustments, finish with the procedure titled "To Permanently Store CCs in the Analyzer," part of "Storing and Recalling CC," at the end of this chapter..

6. If you ARE going to make more adjustments, save the correction constant data that you've generated so far. Insert a formatted disk into the internal disk drive. Press **SYSTEM OPTIONS** **Service** **Update Corr Const** **Store CC to Disk**. This creates a file (or writes over an existing file) with the name "CC_data."

SWITCHED GAIN CORRECTION ADJUSTMENT

In this procedure, the HP 8711 sets the gain for each analyzer input. The HP 8711 can apply different gains to the R, A, and B input signals to make sure that the signal is in the correct range for proper ADC (analog to digital converter) operation.

If you press the **Prior Menu** key during this adjustment, the analyzer will abort the test.

Caution Place the analyzer on an anti-static mat and wear a connecting wrist strap when making this adjustment.



Equipment	Recommended Model or Part Number	
	50 ohm (std)	75 ohm (opt. 1EC)
Type-N cable	HP p/n 8120-4781	HP p/n 8120-2408
30 dB attenuator, SMA	HP 8493A opt. 030	HP 8493A opt. 030
Cable, SMA(m)-SMA(m)	HP p/n 08360-20105	HP p/n 08360-20105

1. Remove the handles and front panel.
 - a. Remove the trim strip on the side of the handles.
 - b. Remove the screws that attach the handles to the analyzer frame.
 - c. Pull the analyzer toward you to extend about two inches over the tabletop.
 - d. Grasp and pull the front panel with two hands: one on the top-middle of the panel, and the other on the bottom-middle of the panel.

(You can disconnect the front panel ribbon cable to move the front panel out of the way, but you need to reconnect it later so you can press the necessary softkeys for the test.)

2. Press **SYSTEM OPTIONS** **Service** **Test and Adjustments** **Select Adjustment** **1 0 2** **ENTER** **Execute Test**.
3. Disconnect the SMA cable between the source (A4J4) and receiver (A5J3) on the far right.
4. Connect a 30 dB attenuator and another SMA cable between the source (A4J4) and receiver (A5J3), as shown in Figure 3-8.

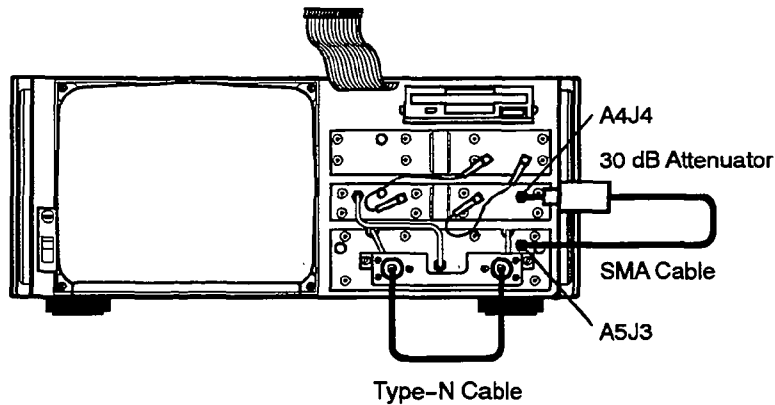

Figure 3-8. Setup for Switched Gain Correction

5. Connect a type-N cable between the REFLECTION and TRANSMISSION ports, as shown in Figure 3-8.
6. Press **Connected for R & B** (top softkey). The analyzer adjusts switched gain for the B and R inputs.
7. When the prompt appears in the dialogue box, disconnect the type-N cable between the REFLECTION and TRANSMISSION ports.
8. Press **Disconnect for A** (top softkey). The analyzer adjusts switched gain for the A input.

If the analyzer fails the adjustment test, resulting in a warning message, check the cable setup and rerun the test.

9. After the test is done, remove the 30 dB attenuator and put the original SMA cable back.

The analyzer presets after the test is done.

10. Reassemble the front panel and handles.
11. If you are NOT going to make any more adjustments, finish with the procedure titled "To Permanently Store CCs in the Analyzer," part of "Storing and Recalling CCs" at the end of this chapter.
12. If you ARE going to make more adjustments, save the correction constant data that you've generated so far. Insert a formatted disk into the internal disk drive. Press **SYSTEM OPTIONS** **Service** **Update Corr Const** **Store CC to Disk**. This creates a file (or writes over an existing file) with the name "CC_data".

EXTERNAL DETECTOR CORRECTION ADJUSTMENT

This procedure shows you how to generate correction constants for the receiver to make external detector or internal broadband measurements. Perform this test whether or not you plan to use external detectors. The external detectors (HP 86200A and HP 86201A) convert the detected power level into voltages. These voltages are then routed to the receiver through the X and Y external detector inputs on the rear panel of the HP 8711.

If you press the **Prior Menu** key during this adjustment, the analyzer will abort the test.

Equipment	Recommended Model or Part Number
Detector input adapter	(part of HP 8711 service kit)
Dual output DC power supply	HP 6234A or 6205C
Voltmeter	Any

1. Press **SYSTEM OPTIONS** **Service** **Test and Adjustments** **Select Adjustment** **103** **ENTER** **Execute Test**.
2. Attach the detector adapter to the X detector input, and connect the wires together.
This supplies zero volts between pins D (red connector, V+) and C (black connector, V-) of the detector connector.
Press **Connected 0V**.
3. When the prompt is displayed in the dialogue box, disconnect the adapter wires.
4. Use the voltmeter to set one of the DC power supplies to -0.5 volts, and the other DC power supply to +0.5 volts.
5. Apply the +0.5V to pin D (red connector) and the -0.5V to pin C (black connector). Connect ground to pin K (green connector).
Press **Connected plus 1.0V**.
6. When the measurements are done, disconnect the adapter from the power supply.
7. Move the detector adapter to the Y detector input. Repeat steps 2 through 6.
If the analyzer fails the adjustment test, resulting in a warning message, check the connections and voltages and rerun the test.
8. If you are NOT going to make any more adjustments, finish with the procedure titled "To Permanently Store CCs in the Analyzer," part of "Storing and Recalling CCs" at the end of this chapter..
9. If you ARE going to make more adjustments, save the correction constant data that you've generated so far. Insert a formatted disk into the internal disk drive. Press **SYSTEM OPTIONS** **Service** **Update Corr Const** **Store CC to Disk**. This creates a file (or writes over an existing file) with the name "CC_data."

AUX IN CORRECTION ADJUSTMENT

(Firmware rev 2.00 and above)

This procedure shows you how to generate correction constants for the Aux Input. The procedure measures two voltages to compute the offset and gain of the aux input circuitry.

If you press the **Prior Menu** key during this adjustment, the analyzer stops the test.

Equipment	Recommended Model or Part Number
DC power supply	Any
Voltmeter	Any
BNC cable	Any
Adapter, BNC (m) to clip leads	Any

1. Press **Service** **Test and Adjustments** **Select Adjustment** **111** **ENTER** **Execute Test** .
2. Connect the BNC cable to the aux input on the rear panel of the analyzer.
3. Connect clip leads to BNC cable and apply a short by connecting the two clip leads together and press **Connected 0V** .
4. At the prompt, connect the clip leads to a +10V power supply (observe polarity).
5. Monitor the power supply voltage with the voltmeter, adjust it to +10V +/-0.005V, press **Connected 10V** .
6. If you are NOT going to make any more adjustments, finish with the procedure titled "To Permanently Store CCs in the Analyzer," part of "Storing and Recalling Correction Constants," at the end of this chapter.
7. If you ARE going to make more adjustments, save the correction constant data that you've generated so far: insert a formatted disk into the internal disk drive. Press **SYSTEM OPTIONS** **Service** **Update Corr Const** **Store CC to Disk** . This creates a file (or writes over an existing file) with the name "CC_data".

SOURCE POWER (ALC) CORRECTION ADJUSTMENT

In this procedure, the analyzer creates a table of values that corrects the source output power over different frequencies and power levels. The HP 8711 reads values from a power meter to determine the actual source output level. An HP 437B or HP 438A (with firmware revision 3.0 or greater) power meter is required for this test. Other power meters will not be controlled correctly by the analyzer.

If your HP 8711 has a step attenuator installed, (option 1E1) you need an HP 8481D option H70 power sensor for part of the adjustment procedure. (The option H70 has a 100 kHz to 4 GHz frequency range.)

This adjustment takes approximately five to ten minutes to run, depending on the installed options.

If you press the **Print Menu** key during this adjustment, the analyzer will abort the test.

Equipment	Recommended Model or Part Number	
	50 ohm (std)	75 ohm (opt. 1EC)
Power meter	HP 437B/438A	HP 437B/438A
Power sensor	HP 8482A	HP8482A
High sensitivity power sensor (for opt. 1E1 instruments only)	HP 8481D opt H70	HP 8481D opt H70
10 dB attenuator	HP 8491A opt 010	
Minimum loss pad		HP 11852B
HP-IB cable	HP 10833A	HP 10833A

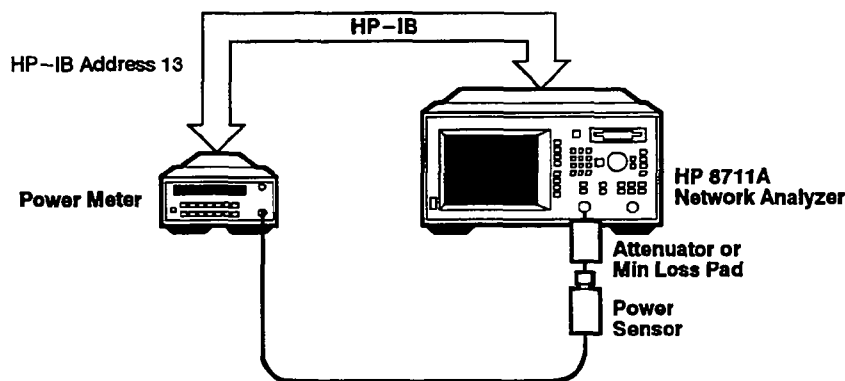

Figure 3-9. Setup for Source Power Correction



Note Before you begin this adjustment, you should store a copy of the correction constants in a disk file for later retrieval, if you haven't done so already. Refer to the procedure in "Storing and Recalling Correction Constants."

1. Switch on the power meter and let it warm up for at least five minutes.
2. Connect an HP-IB cable between the HP 8711 and the power meter. Set the HP-IB address of the power meter to 13. Disconnect any controller that may be on the HP-IB bus.
3. Connect the HP 8482A power sensor to the power meter. (If you are using an HP 438A connect the input to the A port.) Zero and calibrate the power meter using the instructions in the power meter manual.
4. Press **PRESET** **SYSTEM OPTIONS** **Service** **Test and Adjustments** **Select Adjustment** **104** **ENTER** **Execute Test**.
5. When prompted, connect the 10 dB attenuator and power sensor to the REFLECTION port.
 - For 75 ohm instruments, use the minimum loss pad instead of the attenuator.
 Press **High Power Connected** to continue.
6. **For 50 ohm instruments only.** At the next prompt, remove the attenuator and connect the power sensor directly to the REFLECTION port. Press **Connected High Power** to continue.
7. If your instrument DOES NOT have a step attenuator, go to step 10.
8. **For all instruments with a step attenuator (option 1E1).** When prompted, disconnect the HP 8482A power sensor from the power meter and connect the HP 8481D option H70.

IMPORTANT! Preset the power meter. Connect the calibrated HP 11708A 30 dB attenuator (part of the HP 8481D sensor shipment), to the POWER REF output of the power meter. Connect the HP 8481D option H70 to the HP 11708A, then zero and calibrate the power sensor.

9. **For 50 ohm instruments:** Connect the HP 8481D (excluding the 30 dB attenuator) to the REFLECTION port.

For 75 ohm (option 1EC) instruments: Connect an HP 11852B minimum loss pad to the REFLECTION port before connecting the power sensor.

 Press **Connected Lo Power** to complete the adjustment.
10. **For all instruments.** When the test is done, disconnect the power sensor and press **Disconnect Pwr Mtr**.

Then press **PRESET** **SYSTEM OPTIONS** **HP-IB** **Talker/Listener**.
11. If you are NOT going to make any more adjustments continue with procedure titled "To Permanently Store CCs in the Analyzer," part of "Storing and Recalling CCs" at the end of this chapter.
12. If you ARE going to make more adjustments, save the correction constant data that you've generated so far. Insert a formatted disk into the internal disk drive. Press **SYSTEM OPTIONS** **Service** **Update Corr Const** **Store CC to Disk**. This creates a file (or writes over an existing file) with the name "CC_data".

In Case of Difficulty

If the system locks up or the power meter does not respond to the analyzer, make sure the HP-IB cable is correctly connected and the HP-IB address on the power meter is set to 13.

If a "log error" occurs on the power meter during the low power adjustment and the test stops, you will need to do the test again. Turn off the HP 8711 and preset the power meter. If you did not store the correction constants to disk before starting this adjustment, you need to repeat all of the adjustments done up to this point, then repeat the source power correction. If you did save the correction constants to disk, recall the correction constants data from disk (as described in "Storing and Recalling Correction Constants"), then go back to step 1 to repeat this test.

B AMPLITUDE CORRECTION ADJUSTMENT

This procedure shows you how to correct the B narrowband input so that it displays a flat 0 dB trace with an input of 0 dBm from the analyzer's internal source.

If you press the **Proc Menu** key during this adjustment, the analyzer will abort the test.

Equipment	Recommended Model or Part Number	
	50 ohm (std)	75 ohm (opt. 1EC)
Type-N cable	HP p/n 8120-4781	HP p/n 8120-2408

1. Connect a cable from the REFLECTION port to the TRANSMISSION port.
2. Press **SYSTEM OPTIONS** **Service** **Test and Adjustments** **Select Adjustment** **105** **ENTER** **Execute Test** **Measure Standard**. The analyzer averages a number of sweeps together, taking about two minutes to complete.
3. If you are NOT going to make any more adjustments continue with procedure titled "To Permanently Store CCs in the Analyzer," part of "Storing and Recalling CCs" at the end of this chapter.
4. If you ARE going to make adjustments, save the correction constant data that you've generated so far: insert a formatted disk into the internal disk drive. Press **SYSTEM OPTIONS** **Service** **Update Corr Const** **Store CC to Disk**. This creates a file (or writes over an existing file) with the name "CC_data".

TRANSMISSION (B/R) CORRECTION ADJUSTMENT

This procedure shows you how to perform a transmission response calibration to correct for frequency response in narrowband B/R measurements.

If you press the **Prior Menu** key during this adjustment, the analyzer will abort the test.

Equipment	Recommended Model or Part Number	
	50 ohm (std)	75 ohm (opt. 1EC)
Type-N cable	HP p/n 8120-4781	HP p/n 8120-2408

1. Connect a cable from the REFLECTION port to the TRANSMISSION port.
2. Press **SYSTEM OPTIONS** **Service** **Test and Adjustments** **Select Adjustment** **106** **ENTER** **Execute Test** **Measure Standard**. (The analyzer uses averaging for completing the test.)
3. If you are NOT going to make any more adjustments, finish with the procedure titled "To Permanently Store CCs in the Analyzer," part of "Storing and Recalling CCs," at the end of this chapter.
4. If you ARE going to make adjustments, save the correction constant data that you've generated so far: insert a formatted disk into the internal disk drive. Press **SYSTEM OPTIONS** **Service** **Update Corr Const** **Store CC to Disk**. This creates a file (or writes over an existing file) with the name "CC_data".

REFLECTION (ONE PORT) CORRECTION ADJUSTMENT

This procedure shows you how to correct for errors in reflection measurements. You measure an open, short, and load with the HP 8711 to perform a one-port reflection calibration.

If you press the **Prior Menu** key during this adjustment, the analyzer will abort the test.

Equipment	Recommended Model or Part Number	
	50 ohm (std)	75 ohm (opt. 1EC)
Calibration kit	HP 85032B/E	HP 85036B/E

1. Press **SYSTEM OPTIONS** **Service** **Test and Adjustments** **Select Adjustment** **107** **ENTER** **Execute Test**.
2. Connect the male calibration kit devices to the REFLECTION port when prompted on the analyzer screen. Press **Measure Standard** after each device is connected.
3. If you are NOT going to make any more adjustments, finish with the procedure titled "To Permanently Store CCs in the Analyzer," part of "Storing and Recalling CCs," at the end of this chapter.
4. If you ARE going to make more adjustments, save the correction constant data that you've generated so far. Insert a formatted disk into the internal disk drive. Press **SYSTEM OPTIONS** **Service** **Update Corr Const** **Store CC to Disk**. This creates a file (or writes over an existing file) with the name "CC_data."

R* AMPLITUDE CORRECTION ADJUSTMENT

This procedure shows you how to generate correction constants to improve absolute power accuracy in R* measurements. (Frequency effects are corrected in "R* Frequency Response Correction: Test #109.")

If you press the **Prior Menu** key during this adjustment, the analyzer will abort the test.

Equipment	Recommended Model or Part Number	
	50 ohm (std)	75 ohm (opt. 1EC)
Type-N (m) Termination	HP p/n 00909-60009	HP p/n 00909-60019

Caution



You must run adjustment tests 103 (ext det corr) and 104 (source power) before running the R* amplitude correction adjustment.

1. Connect a termination (included in the HP 85032B/E or 85036B/E calibration kit) to the REFLECTION port.
2. Press **SYSTEM OPTIONS** **Service** **Test and Adjustments** **Select Adjustment** **108** **ENTER** **Execute Test**.

At the beginning of the test, the analyzer is measuring low power levels that are below the displayed range. The message "data?" periodically appears in the upper-left of the screen when the analyzer is making measurements. The analyzer also displays a message and then presets when the test is complete.

If the analyzer displays an error message and aborts the adjustment, the calibration data from tests 103 and 104 are probably bad.

3. If you are NOT going to make any more adjustments, finish with the procedure titled "To Permanently Store CCs in the Analyzer," part of "Storing and Recalling CCs," at the end of this chapter.
4. If you ARE going to make more adjustments, save the correction constant data that you've generated so far. Insert a formatted disk into the internal disk drive. Press **SYSTEM OPTIONS** **Service** **Update Corr Const** **Store CC to Disk**. This creates a file (or writes over an existing file) with the name "CC_data".

R* FREQUENCY RESPONSE CORRECTION ADJUSTMENT

This procedure shows you how to correct for frequency response errors in R* measurements.

If you press the **Print Menu** key during this adjustment, the analyzer will abort the test.

Equipment	Recommended Model or Part Number	
	50 ohm (std)	75 ohm (opt. 1EC)
Type-N (m) Termination	HP p/n 00909-60009	HP p/n 00909-60019

1. Connect a termination (included in the HP 85032B/E or 85036B/E calibration kit) to the REFLECTION port.
2. Press **SYSTEM OPTIONS** **Service** **Test and Adjustments** **Select Adjustment** **109** **ENTER** **Execute Test** .
The analyzer displays a message and presets when the test is complete.
3. If you are NOT going to make any more adjustments, finish with the procedure titled "To Permanently Store CCs in the Analyzer," part of "Storing and Recalling CCs," at the end of this chapter.
4. If you ARE going to make more adjustments, save the correction constant data that you've generated so far. Insert a formatted disk into the internal disk drive. Press **SYSTEM OPTIONS** **Service** **Update Corr Const** **Store CC to Disk** . This creates a file (or writes over an existing file) with the name "CC_data".

B* AMPLITUDE CORRECTION ADJUSTMENT

This procedure shows you how to increase the absolute power accuracy in B* measurements. First, the HP 8711 sets up a 30 MHz signal and applies power levels of -54 dBm to +18 dBm (in 2 dB steps) to the B* input. Then the analyzer compares the measured value to the nominal value and generates a correction table.

To perform this procedure you need an HP BASIC controller. The controller uses the power meter to accurately set the level of an external source, and signals the HP 8711 when the level is correct. This external source signal is then measured by the B* input.

If you press the **Prior Menu** key during this adjustment, the analyzer will abort the test.

Caution

You must run adjustment test 103 (ext det corr) before running the B* amplitude correction adjustment.



Equipment	Recommended Model or Part Number	
	50 ohm (std.)	75 ohm (opt. 1EC)
HP BASIC controller with BASIC 5.0 or higher	HP 9000 series 200/300	HP 9000 series 200/300
Test software	HP p/n 08711-10009	HP p/n 08711-10009
Signal generator	HP 8116A	HP 8116A
Power divider	HP 11636A	
75 ohm power splitter		HP 11850D
Power meter	HP 437B or 438A	HP 437B or 438A
Power sensor	HP 8482A	HP 8483A
High sensitivity power sensor	HP 8481D opt H70	HP 8481D opt H70
50 MHz reference attenuator	HP 11708A	HP 11708A
Minimum loss pad		HP 11852B
30 MHz bandpass filter	9135-0475	9135-0475
75 ohm termination		HP p/n 00909-60019
Step attenuator	HP 8496A/G	HP 8496A/G
Attenuator/Switch driver (optional)	HP 11713A	HP 11713A
HP-IB cables (3 or 4)	HP 10833A	HP 10833A
Type-N cables (2)	HP p/n 8120-4781	HP p/n 8120-4781
Adapter, N(m) to N(m)	HP p/n 1250-1475	HP p/n 1250-1528
Adapter, BNC(m) to N(f)	HP p/n 1250-0077	HP 1250-0077
Adapter, N(f) to N(f)	HP p/n 1250-1472	

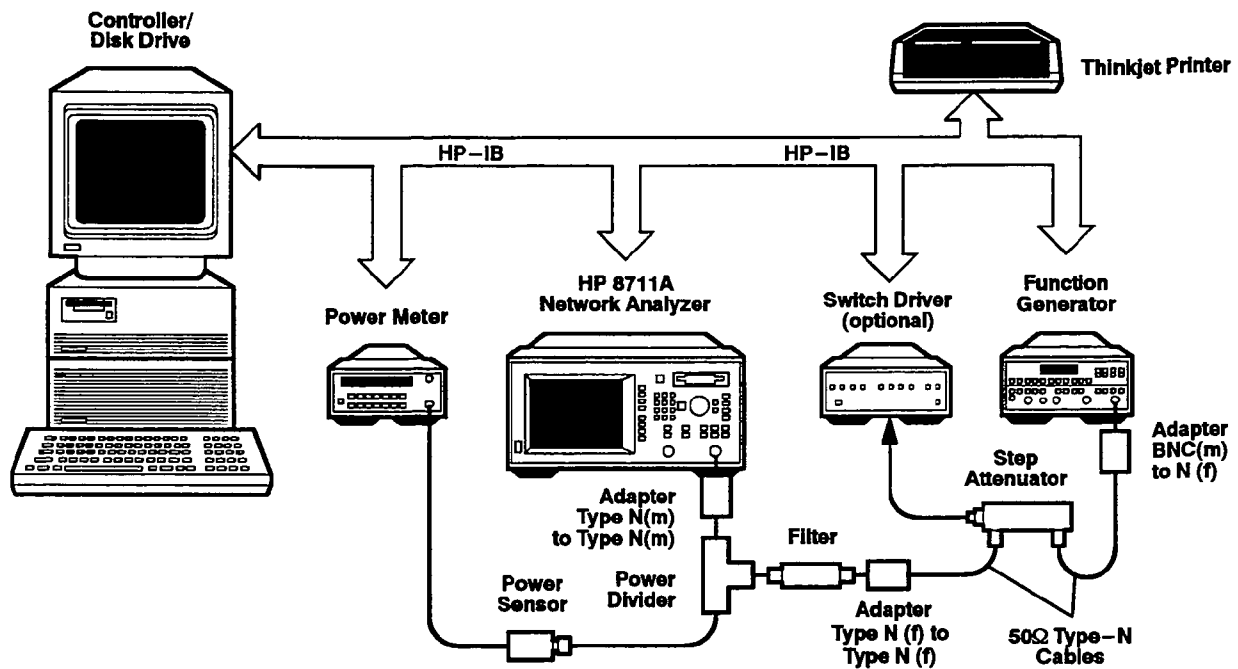

Figure 3-10. Setup for B* Amplitude Correction with 50 ohm Equipment

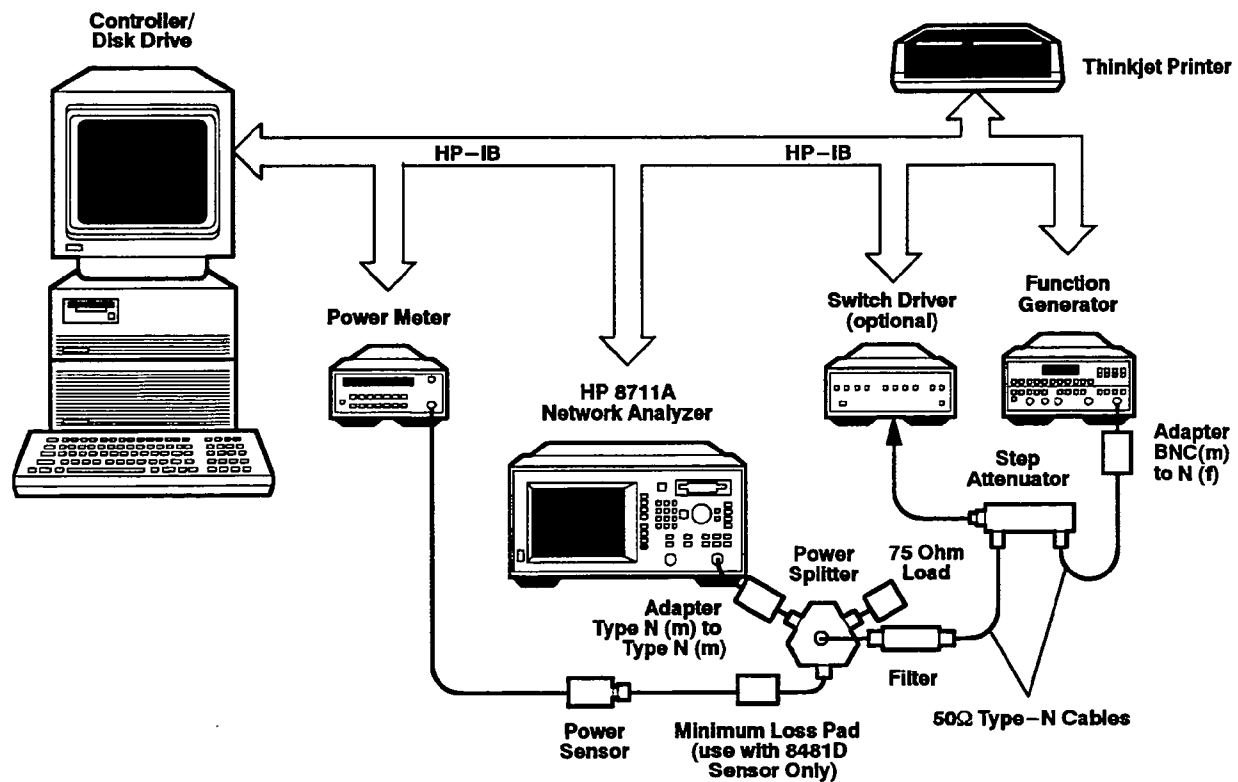

Figure 3-11. Setup for B* Amplitude Correction with 75 ohm Equipment

1. Connect the equipment as shown in Figure 3–10 or Figure 3–11, depending on the impedance of the HP 8711 you are adjusting. Do not connect the power sensor to the divider or splitter, since you will calibrate the the power meter during the adjustment.
2. Refer to the procedure in “Loading and Running the Test Software” in the “Performance Tests” chapter to load and run the performance test/adjustment software. Choose “1” when asked to select which device you want to test.
3. Select “PERFORMANCE & ADJUSTMENT TESTS” from the main menu displayed on the controller screen.
4. The program asks you to input some information if a data file does not exist for your analyzer. Follow the prompts to enter the information.

If a data file does exist, the program asks if you want to change the report header (includes information on the technician’s name, date of test, temperature, and humidity conditions). Follow the prompts to update this information if necessary.

5. Using the cursor keys, move the arrow pointer to “B* Amplitude Adjustment” and press **SELECT**.
6. Enter the calibration factor at 30 MHz for the two power sensors you are using for the adjustment.
7. Choose the power meter input port where you connected the power sensor and press **SELECT**. Use input A if you have an HP 438A.
8. Connect the HP 8481D power sensor and the 30 dB reference attenuator (part of the HP 8481D shipment) to the POWER REF port on the power meter and press any key to continue. Follow the prompts to zero and calibrate the power meter.
9. Connect the power sensor to the power divider (or minimum loss pad for 75Ω systems), excluding the 30 dB reference attenuator, and press any key to continue.

The controller uses the power meter to set HP 8711 power levels accurately, then signals the analyzer when the level is correct. The analyzer then reads the power measured and calculates the appropriate correction constants. The power level being set, and the power level error of each iteration is displayed on the controller screen.

The HP 8481D power sensor is used at low power levels. At higher power levels, the program prompts you to connect either an HP 8482A or HP 8483A. For 75 ohm systems, remove the minimum loss pad from the power splitter.

If the analyzer displays an error message and aborts the adjustment, the calibration data from test 103 is probably bad.

10. Follow the prompts to complete the adjustment.

Storing and Recalling Correction Constants

Note



To update firmware or correction constants, you must erase **both** first. Therefore, you **MUST** have a firmware disk available to update correction constants (because you cannot make a firmware disk yourself). The figure below illustrates the flow of CCs in the analyzer.

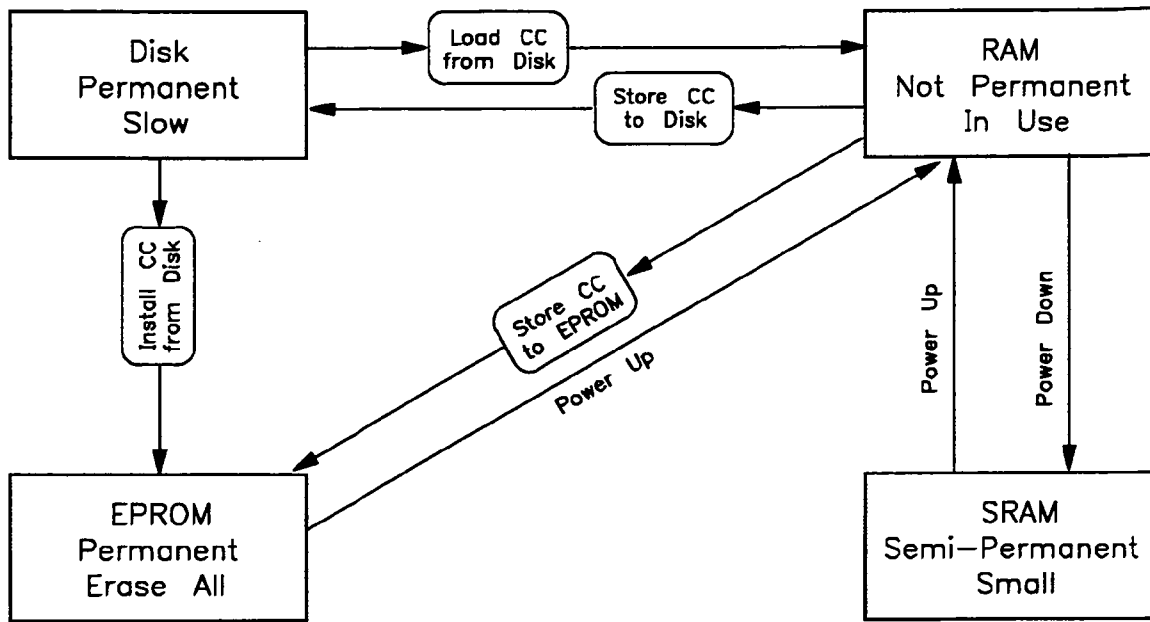

sd65a

Figure 3-12. Correction Constants Flow by Keystroke and Cycling Power

To Permanently Store CCs in the Analyzer

Typically, you have just completed the last service adjustment. The CCs are now in RAM (volatile memory).

To permanently store all of the CCs in EPROM (non-volatile), perform (and check):

- [] step 1, below (Storing Correction Constants to Disk)
- [] step 2, below (Updating or Restoring Firmware)
- [] step 3, below (Installing Correction Constants)

To Temporarily Store CCs to Disk for Later Recall

Perform the following step:

- [] step 1, below (Storing Correction Constants to Disk)

To Recall CCs from Disk

Perform the following step:

- [] step 4, below (Loading Correction Constants from Disk)

To Restore Previous CCs after Replacing the A2 CPU Board

Perform (and check):

- [] step 2, below (skip this step if A2 was supplied with firmware already installed)
- [] "Set Serial Number Adjustment," earlier in this chapter
- [] step 3, below (Installing Correction Constants)

To Replace Suspected Incorrect CCs

Perform (and check):

- [] step 2, below (Updating or Restoring Firmware)
- [] step 3, below (Installing Correction Constants)

To Archive Current CCs to Disk

Perform (and check):

- [] cycle power (to clear any temporary CCs in RAM)
- [] step 1, below (Storing Correction Constants to Disk)

If "ROM Appears to be Blank" Message is Displayed at Power-up

Perform (and check):

- [] step 2, below (Updating or Restoring Firmware)
- [] step 3, below (Installing Correction Constants from Disk)

If "Warning: No Correction Constants Installed" Is Displayed at Power-UP

Perform (and check):

- [] step 3, below (Installing Correction Constants from Disk)

Step 1. Storing Correction Constants to Disk

- a. Insert a formatted disk into the internal disk drive.

Note



Do not use the correction constants disk shipped with the analyzer unless you are certain that the data on it is no longer needed.

- b. Press **SYSTEM OPTIONS** **Service** **Update Corr Const** **Store CC to Disk**. The instrument writes (or overwrites) a file named "CC_data."

Step 2. Updating or Restoring Firmware

a. Insert the firmware disk and cycle power: the analyzer indicates that it detects a firmware disk and is about to install the new firmware. Press **BEGIN**.

Step 3. Installing Correction Constants from Disk

Note



Note: this step automatically recalls CCs from disk and stores the CCs in EPROM.

- a. Insert the correction constants disk into the internal disk drive.
- b. Press **SYSTEM OPTIONS** **Service** **Update Corr Const** **Install CC from Disk**.
- c. When the CCs have been installed from disk, cycle power.

Step 4. Loading Correction Constants from Disk

- a. Insert the correction constants disk into the internal disk drive.
- b. Press **SYSTEM OPTIONS** **Service** **Update Corr Const** **Load CC from Disk** : the analyzer loads the CCs from disk into RAM.

Troubleshooting

HP 8711A System Troubleshooting

Start here to troubleshoot problems with the HP 8711. The goal of this section is to differentiate between HP 8711 system problems caused by the analyzer and problems caused by its peripherals.

General Notes

1. ALWAYS turn the instrument power off before removing or installing an assembly.
2. If you need to disassemble the instrument, be sure to work at an antistatic workstation and use a grounded wrist strap to prevent damage from electrostatic discharge (ESD).
3. For disassembly procedures, see the "Replaceable Parts" chapter of this manual. Some parts in the instrument have sharp edges. Work carefully to avoid injury.
4. Before replacing an assembly, inspect the board for obvious, easy-to-fix defects. Examples include bent pins on ICs, no solder in holes around the edges of shields, and cold solder joints.

Initial Observations

Prepare the analyzer for observation by performing these steps:

1. Disconnect all accessories and peripherals.
2. Remove the disk (if any) from the internal disk drive.
3. Connect a cable between RF OUT and RF IN (the reflection and transmission ports).

Turn on the analyzer and watch for the proper turn-on sequence:

1. Disk drive light goes on briefly, and a "beep" is audible from the CPU.
2. The CRT lists the boot ROM self-tests being performed.
3. Disk drive light goes on. Firmware loads from ROM. The analyzer beeps twice when this is done.
4. The CRT displays the status of the main self-tests.
5. During the next 5 seconds these messages appear on CRT:

"Initializing"

"Calculating correction coefficients"

6. The graticule is displayed along with information on the model number, firmware revision, and installed options.

Press **PRESET**. The display should show a transmission trace (a flat line at 0 dB). If not make sure the cable between the RF OUT and RF IN ports is good.

If the analyzer does not turn on, check the AC line power. Make sure that the line voltage selector (below AC power plug) is set correctly. Check the fuse.

If the analyzer does not go through the steps above, or if any error messages appear, or if the problem persists, refer to "Troubleshooting the Analyzer," following.

Operator's Check

Perform the "Operator's Check" procedure in the "Performance Tests" section of this manual. It is a simple test of the analyzer's measurement capability. If the test passes and peripherals are not involved, duplicate the operating conditions under which the system failed and refer to "Troubleshooting the Analyzer" if the problem reappears.

Troubleshooting Peripheral Problems

DIN Keyboard

If a DIN keyboard interface test failure was reported during power-up, there may be a problem with the +5V power supply for the DIN keyboard. Disconnect the keyboard, remove the CPU board, and check the +5V fuse next to the DIN connector. If necessary, replace it with the spare fuse provided.

Verify that the keyboard is connected properly. Make sure that the keyboard is compatible with the HP 8711. The analyzer should work with HP DIN keyboards that are U.S. English versions, and most (but not all) IBM PC/AT compatible keyboards. Refer to "Installing the HP 8711" in the **Operating and Programming** manual for a part number of keyboard that definitely works with the HP 8711.

Connect the keyboard to a computer or another analyzer to see if it is functioning, or try using a different keyboard. If the keyboard works with other instruments, replace the CPU board.

RS-232 Printers and Plotters

If an RS-232 interface problem was reported during power-up (with no peripheral connected), there may be a problem with the RS-232 DUART chip, U5, or its 3.6864 MHz clock, U4. Replace the CPU board, or refer to the HP 8711 Schematic Package (available separately) to troubleshoot further.

Make sure the printer or plotter has power turned on, paper, pens, pinch wheels down, and so forth. Plotters should not be in VIEW mode. Verify that the RS-232 device has been selected as the hardcopy device by pressing **HARDCOPY** **Select Copy Port**. The first line on the CRT shows the current device selection. The second line shows the baud rate, parity, and handshake information. If any of this is incorrect, enter the correct information. Refer to the printer or plotter manual for proper parameters. Refer to the HP 8711 Operating and Programming manual for more details on hardcopy options.

Try to make a print or plot from another instrument or a computer to confirm that the printer/plotter is working. If it is, replace the CPU board.

Centronics Printers and Plotters

If a Centronics interface problem is indicated during power-up (with no peripheral connected), there may be a problem with the Centronics control chips (U2, U3, U35). Replace the CPU board, or refer to the HP 8711 Schematic Package (available separately) to troubleshoot further.

Make sure the printer or plotter has power turned on, paper, pens, pinch wheels down, and so forth. Plotters should not be in VIEW mode. Verify that the Centronics device has been selected as the hardcopy device by pressing **HARDCOPY** **Select Copy Port**. The first line on the CRT shows the current device selection. The second line should say "Centronics." If this is incorrect, enter the correct information. Refer to the HP 8711 Operating and Programming manual for more details on hardcopy options.

If everything seems okay but you still can't print or plot, remove the CPU board and check jumper J45, near the HP-IB and parallel connectors at the rear of the board. Make sure the jumper is in the "RUN" position instead of "TEST."

Try to make a print or plot from another instrument or a computer to confirm that the printer/plotter is working. If it is, replace the CPU board.

HP-IB Systems

If an HP-IB interface problem is indicated during power-up (with nothing connected to the HP-IB port), there may be a problem with the HP-IB controller chip (U9) or the interface chips (U10, U34). Replace the CPU board, or refer to the HP 8711A Schematic Package (available separately) to troubleshoot further.

Check the analyzer's HP-IB functions with a known working peripheral such as a plotter, printer, or disk drive. Press **PRESET** **SYSTEM OPTIONS** **HP-IB** **System Controller** to allow the analyzer to control the peripheral. Check the HP-IB address on the peripheral, then set the analyzer to recognize this address by doing the following:

HP-IB Problems with Printers or Plotters

For HP-IB printers or plotters, press **HARDCOPY** **Select Copy Port** and select the appropriate HP-IB device. The currently selected device is shown on the first line of the display, and for HP-IB devices, the HP-IB address is shown on the second line.

To change the address, press **Hardcopy Address** and enter the correct value (from 1 to 30). Note that the default HP-IB address recognized by the HP 8711 for both printers and plotters is 5, but the factory default address of a printer is 1.

Make sure the printer or plotter has power turned on, paper, pens, pinch wheels down, and so forth. Plotters should not be in VIEW mode. Press **Prior Menu** **Start** to do a print or plot. If the result is not a copy of the display (as selected by **Define Hardcopy**), suspect HP-IB problems in the analyzer.

HP-IB Problems with Disk Drives

For disk drives, press **SAVE RECALL** **Select Disk** **Configure Ext Disk** and set the correct address, disk unit, and disk volume numbers. Default values for all three are zero.

Press **Prior Menu** **External Disk** to select the external disk drive. The second line should begin with "EXT:".

Press **Prior Menu** **Save State** to store a file to the disk. If this is not successful, suspect HP-IB problems in the analyzer.

General Checks for HP-IB Systems

Make sure the controller is compatible (HP 9000 series 200/300 with HP-IB and I/O binaries loaded). Some PCs with GP-IB interface cards may also be compatible.

Make sure the controller is using the proper select code and addresses.

Be sure HP-IB cable length limits are not exceeded. See “Installing the HP 8711” in the Operating and Programming manual.

Refer to the “HP-IB Programming” chapter of the Operating and Programming manual to troubleshoot programming problems.

Replace the CPU board or refer to the HP 8711 Schematic Package to troubleshoot further if the analyzer appears to have an HP-IB problem.

Troubleshooting the Analyzer

Use these procedures if you have read the “HP 8711A System Troubleshooting” section and you think the problem is in the analyzer. These procedures verify each of the main functional groups in sequence, to determine which board is faulty.

The functional groups are power supply, digital control, source, and receiver. Descriptions of these groups are provided in “Theory of Operation.”

The procedure in the following pages must be performed in the order presented. Do not skip sections unless you are instructed to do so.

GENERAL NOTES

1. **ALWAYS** turn the instrument power off before removing or installing an assembly.
2. If you need to disassemble the instrument, be sure to work at an antistatic workstation and use a grounded wrist strap to prevent damage from electrostatic discharge (ESD).
3. For disassembly procedures, see the “Replaceable Parts” chapter of this manual. Some parts in the instrument have sharp edges. Work carefully to avoid injury.
4. Before replacing an assembly, inspect the board for obvious, easy-to-fix defects. Examples include bent pins on ICs, no solder in holes around the edges of shields, and cold solder joints.
5. To confirm the problem or troubleshoot further, refer to the “Detailed Troubleshooting” section of this chapter or the HP 8711 Schematic Package (available separately) for more information.

TROUBLESHOOTING POWER SUPPLY (PS) PROBLEMS

Check the Rear Panel LEDs

Turn the instrument power on. Check the condition of the two LEDs visible through the hole in the rear panel to the right of the AC power plug.

Green LED on & red LED off: normal condition. Continue with “Measure Power Supply Voltages” to confirm that the power supplies are okay.

Neither LED on: check the line fuse, located in a holder above the AC power jack, and replace it with the spare provided if necessary. Check the AC power line. If there are still no LEDs on, replace the power supply.

Green LED on, red LED on steadily, fan off: check the line voltage selector switch, located below the AC power jack. If it is correct, remove the PS/display assembly and make sure that the cable from the on/standby switch to the power supply assembly is connected (see Figure 7-7).

With the PS/display assembly outside the analyzer, plug it in and turn on the power.

Fan still off: check the 4 green PS LEDs visible from the right side of the display enclosure (as viewed from the front). If the LEDs are on, the fan is probably broken. Replace the PS assembly.

Green LED on, red LED on steadily, fan on: go to “Measure Power Supply Voltages.” Note that it is normal for both the green and red LEDs to be on when the power switch is in STANDBY, but not when the switch is ON.

Green LED on, red LED blinking: the power supply is in shutdown. Remove the PS/display from analyzer, plug it in and turn on the power.

Red LED still blinking: replace the PS.

Red LED now off: go to “Remove Assemblies” (the supply was loaded down by another assembly).

Measure Power Supply Voltages

Remove the backplane cover from the rear panel. Figure 4-1 shows the pinouts for J1. There are 4 main supplies, each with its own return, plus the standby voltage which powers the nonvolatile SRAM on the CPU board. Measure the voltages with a voltmeter; values should be within 5% of nominal.

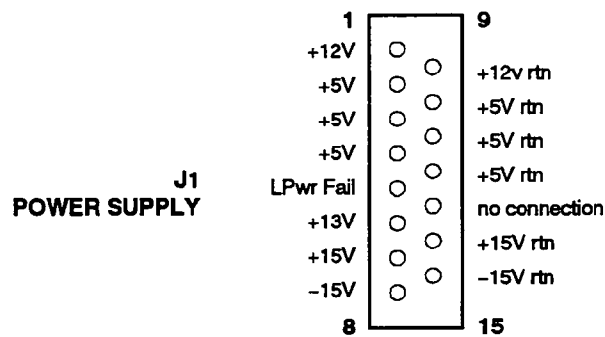

Figure 4-1. Power Supply Connector

Voltages not correct: remove the PS/display assembly, plug in the AC power, and turn it on. Check the four PS LEDs visible from the right side of the display enclosure (as viewed from the front).

One or more LEDs off: replace the PS.

All LEDs on: reseal the PS/display assembly, making sure there's a good connection to the rear panel. Measure the voltages again. If the problem persists, check connectors on PS and on backplane board.

Voltages correct but probe power problem: remove the front panel and check the fuses on the back of the front panel PC board.

Continue with the “Troubleshooting Digital Group Problems” section.

Remove Assemblies

You're here because one of the assemblies is causing the power supply to shut down. This may be caused by the other boards having bad contact with the backplane. Give each board a push to make sure it is all the way in. If the problem persists, remove the assemblies one at a time, and note which one is the cause of the shutdown. Refer to the "Replaceable Parts" chapter of this manual for disassembly instructions.

Note



It's possible for the flexible metal "fingers" or a backplane connector pin to break off and cause a short, so check for loose pieces of metal.

Suggested order for board removal (easiest to hardest):

- A1 front panel
- A7 display (remove the ribbon cable while it's outside the analyzer; reinstall and see if the power supply is still shut down). If A7 appears to be causing shutdown, open the display enclosure cover (see Figure 7-7 in "Replaceable Parts") and make sure the PC board is firmly seated.
- A8 disk drive.
- A3 frac-N/reference.
- A4 source.
- A5 receiver.
- A2 CPU.

TROUBLESHOOTING DIGITAL GROUP PROBLEMS

This group includes the CPU, display, disk drive, and front panel. The frac-N/reference assembly is also needed to provide a 5 MHz reference for the digital signal processor (DSP) on the CPU board.

Remove the disk (if any) from the internal disk drive. Turn on the analyzer and watch for the proper turn-on sequence:

1. Disk drive light goes on briefly, and a "beep" is audible from the CPU.
2. The CRT lists the boot ROM self-tests being performed.
3. Disk drive light goes on. Firmware loads from ROM. The analyzer beeps twice when this is done.
4. The CRT displays the status of the main self-tests.
5. During the next 5 seconds the messages appear on the CRT:
 - "Initializing..."
 - "Calculating correction coefficients..."
6. The graticule is displayed along with information on the model number, firmware revision, and installed options.

If the analyzer follows this sequence with no error messages and no front panel or disk drive problems, continue with the “Troubleshooting Source Group Problems” section.

Find the description of the first problem that occurred and follow the procedure below.

Error During Power-up

No beep at turn-on but CRT display normal: the problem is probably in the sound generator or speaker on the CPU board. Check the sound generator chip (U143) and the speaker (LS1), or replace the CPU board.

No beep at turn-on and no CRT display: the problem is most likely one of two conditions:

1. No power to CPU board (no CPU LEDs on).
2. CPU chip not plugged into its socket (CPU LEDs will be on).

Look through the “Test Results” hole on the rear panel to see if LEDs are on. If no LEDs are on, push the CPU board all the way into the backplane connector to make a good connection. (You will need to remove the PS/display assembly to do this). Note that it is also possible for the board to have a bad or intermittent backplane connection and yet receive enough power to turn on the LEDs.

If the LEDs are on, remove the CPU board (remove rear panel screws first). Remove the shield from the 68020 CPU (in the center of the CPU board) and make sure it is properly seated in its socket. Then reinstall the CPU board, making sure to push it all the way in so that it connects properly with the backplane. If there is still no beep at turn-on and CPU LED continues to display an “8”, replace the CPU (U56) or the entire CPU board.

Disk drive light does not go on: make sure the power (3-wire) cable and ribbon cable are connected from the disk drive to the CPU board. Check the cables. The problem can be either a bad disk drive or bad drive circuitry on the CPU. If an error message appears during power-up about a floppy disk controller error, replace the CPU. Otherwise, replace the disk drive.

No CRT display: adjust the front panel intensity knob clockwise to increase the brightness. Remove the display and check the ribbon cable connection to the CPU board. If the problem persists, check the output from the “Video Out” BNC on the rear panel with an oscilloscope. Check for activity in this signal. The frequency and magnitude may vary.

Video Out signal bad: the video circuitry is probably bad. Replace the CPU or go to the “Detailed Troubleshooting” section to confirm the problem.

Video Out signal good: the problem is most likely either the display assembly or the ribbon cable.

Error occurs while firmware is being loaded (before 2 beeps are heard): reload firmware from disk by inserting the firmware disk into the internal disk drive and turning the instrument power on. Press **BEGIN** at the load firmware query. The process will take a few minutes. Watch the CRT for information during the loading procedure.

If the instrument locks up during or after the firmware loading, try clearing the SRAM: turn off power to the analyzer, then turn it back on. While the analyzer is going through its self-tests (Main and SIMM DRAM tests or shortly afterwards), press **PRESET** a few times. When the analyzer pauses after performing the CPU main self-tests it displays a query about zeroing the non-volatile SRAM. (Note the caution message!) Press **BEGIN** to zero the SRAM. Reload the firmware from disk again.

A self-test fails: the analyzer indicates the number of the first failed self-test in two ways:

1. An error message appears on the CRT.
2. "Test Status" LEDs display a number code corresponding to the number of the failed test.

Test status LEDs: include one red LED, one green LED, and a 7-segment LED which displays the digits 0 through 9. The red and green LEDs are located to the left of the 7-segment LED when viewed from the rear panel.

Test status LEDs code:

Red LED and 7-segment LED on: test numbers 1 through 9.

Green LED and 7-segment LED on: tests 10 through 19.

Only green LED on: all self-tests passed.

Table 4-1 lists the power-up self-tests by number, with a description of the error messages and troubleshooting information. Some of the troubleshooting hints may require the use of a service extender board or the HP 8711 Schematic Package. Reference designators for main ICs (e.g. U32) are noted on the PC boards. Note that replacing the defective board is always an option; you need not troubleshoot to a more detailed level.

Check the Test Status LEDs, then locate that test number in the table to determine what to do. For test numbers above 19, the name of the test is usually in the failure message, so look for the test name in the table. Refer to the "Service Key Menus" section of this manual for detailed descriptions of each test.

Note that not all error messages are listed in the table. Many error messages describe the problem clearly and require no further explanation, so they are not included in this manual.

Table 4-1. HP 8711 Self-Tests (1 of 4)

	<p>1. Some error messages are only partially reproduced, because the remainder of the message is specific to the error (e.g. provides address at which the failure occurred).</p> <p>2. <num> indicates either an address or a value. These may be in decimal or hexadecimal notation.</p>	
	Test	Test Name
1	680x0 Processor	Errors begin with "CPU TEST FAIL." Remove CPU board, make sure U56 is seated its socket. If test still fails, replace CPU board or U56.
2	BootROM Checksum	<p>Errors: Bad checksum table at ... ROM Checksum Failure in bank... Checksum Table is Blank. ROM may be blank. Unexpected ROM Id at <number> Bad ROM count in Checksum table... Bad ROM size in Checksum table...</p> <p>This tests checksum of boot ROM chip: Replace CPU board or U82.</p>
3	Main ROM Checksum	<p>Errors: Same as for test #2.</p> <p>This tests checksum of main flash EPROM. Reload firmware from floppy disk. If test still fails, replace the CPU board or check the EPROM chips U51-U54 and U78 to U81.</p>

Table 4-1. HP 8711 Self-Tests (2 of 4)

Test	Test Name	Applicable Error Messages & Notes
4	Main DRAM	<p>Errors: Memory size too small. Bus error. At address <num>, write <num> read <num>. RAM bit errors: <num> RAM refresh errors: <num></p> <p>Test checks size of main DRAM, writes/reads test patterns. Check reported size of DRAM on power-up display. Memory size should be about 1 MB, typically 1040384 to 1048576 bytes. Replace CPU board or check the following: DRAM control circuitry U38-U41 DRAM data interface chips U69, U84 DRAM address MUX U37, U58, U59, U86, U88 DRAM chips U61-U68</p>
5	SIMM DRAM	<p>Errors: same as for test #4.</p> <p>Test checks size of SIMM DRAM, writes/reads test patterns. Check reported size of SIMM DRAM on power-up display. Size varies depending on options: Standard: Approx. 0.5 MB (typically 524288 bytes) IBASIC (opt. 1C2): 2.0 to 2.5 MB</p> <p>Make sure SIMMs are installed properly: they must be installed in pairs, and larger size ones should be in bank 0.</p> <p>Check switch setting on S2. All switches should be open (up), except for switch 1 if bank 0 contains 256KB SIMMs, switch 2 if bank 0 contains 1 MB SIMMs, or switch 3 if bank 0 contains 4 MB SIMMs. Use of 4 256K SIMM DRAMs is not supported.</p> <p>If problem persists, replace CPU or check the following: Control circuitry U31, U38 Data buffers U76, U77 Address MUX U50, U74, U75</p>
6	340x0 GSP Processor	Performs a test of the TMS 34010 graphics system processor. Tests the display video RAM (VRAM).
7	GSP Video	Tests the video circuitry.
8	(number not used)	Test number not used because test status LED powers up with this as default. An "8" on the LED indicates the 68020 was unable to power-up and execute basic instructions.
9	DSP SRAM	<p>Errors: same as for test #4.</p> <p>Checks program SRAM used by the digital signal processor. Typical memory size about 32768 bytes.</p> <p>Replace CPU, or check SRAM chips U79 and U94; and chips U73, U41, U85, U93, U60, and U89.</p>
10	320C25 DSP Processor	Test not implemented.
11	68020 & 320C25 Communication	Test not implemented.

Table 4-1. HP 8711 Self-Tests (3 of 4)

Test	Test Name	Applicable Error Messages & Notes
12	Backplane Bus	<p>Errors: Reference clock not toggling. Unable to gain control of DSP bus. Cannot perform backplane bus tests. Access error: wrote <num>, read <num>, right shift = <num> Source board: Failed self-test. Receiver board: Failed self-test.</p> <p>Test reads version numbers from frac-N/ref, source, and receiver boards. Checks for 5 MHz clock from frac-N/reference board.</p> <p>Make sure all boards are pushed in and making good contact with backplane.</p> <p>Check 10 MHz output from A3J3. If not found, see "Troubleshooting Source Group Problems." Replace CPU or check U21, U22.</p>
13	Non-volatile SRAM	<p>Errors: SRAM battery test FAILED - Saved states lost. SRAM battery test ERROR - Cannot access SRAM.</p> <p>Tests integrity of battery-backed SRAM, detects loss of power to SRAM. Writes/reads pattern to part of SRAM.</p> <p>Remove CPU board and check battery BT1, replace if needed. Replace CPU board or check U124 controller, U83 SRAM, and U125 voltage regulator.</p>
14	Digital IF Control	Test not implemented.
15	CPU Support Circuitry	<p>Errors: 68901 MFP chip test FAILED. Stuck interrupt.</p> <p>Tests 68901 Multi-Function Peripheral chip and interrupt circuitry.</p> <p>Replace CPU board, or check U133.</p>
16	Analog Bus	<p>Errors: CPU +5V supply is out of range! Vpp Flash Supply is out of range!</p> <p>Tests analog bus ADC on CPU board.</p> <p>Replace CPU, or check power supplies, U109 voltage regulator for Vpp.</p>
17	Real Time Clock	Test not implemented.
18	Front Panel Interface	<p>Error: Front panel keyboard FAILED. Command write timeout. Read input timeout. Clear input buffer failed. Echo byte test failed.</p> <p>Tests front panel control processor.</p> <p>Replace CPU board or check U136, U138.</p>
19	Floppy Disk Controller	<p>Error: Floppy Disk controller FAILED. Error number <num></p> <p>Tests controller chip, accesses registers, writes commands and verifies response.</p> <p>Replace CPU or check U140.</p>

Table 4-1. HP 8711 Self-Tests (4 of 4)

Test	Test Name	Applicable Error Messages & Notes
20	HP-IB Interface	<p>Error: HP-IB test FAILED. Data bit error on these bits: (followed by list)</p> <p>Tests HP-IB interface, writes to chip and verifies response. Test not done if anything connected to HP-IB.</p> <p>Replace CPU board or check U9, U10, U34.</p>
21	RS-232 Interface	<p>Errors: RS-232 interface test FAILED. Bus error. Cannot access. Data bit error on these bits: (followed by list)</p> <p>Tests RS-232 DUART chip, accesses registers on chip, checks for clock input.</p> <p>Replace CPU board or check clock U4, DUART chip U5.</p>
22	DIN Keyboard Interface	<p>Errors: 8042 DIN Keyboard test FAILED Problem with DIN Keyboard Power Supply! Check Fuse.</p> <p>Tests DIN keyboard control processor.</p> <p>Replace CPU board or check clock Y53, processor U13.</p>
23	Centronics Interface	<p>Errors: Centronics port test FAILED. Strobe bit error. Printer reset bit error. Printer select bit error.</p> <p>Test writes to and reads back 3 printer control output lines.</p> <p>Replace CPU board or check U2, U3, U35.</p>
(Higher numbered tests are not run during power-up.)		

Error Occurs During DSP Initialization or Calculating Coefficients

Clear the nonvolatile SRAM: turn off power to the analyzer, then turn it back on. While the analyzer is going through its self tests (Main and SIMM DRAM tests or shortly afterwards), press the **PRESET** key a few times. The analyzer will pause after performing the CPU main self-tests and ask if you want to zero the nonvolatile SRAM. (Note the caution message!) Press **BEGIN** to do so. Continue if the error persists.

5 MHz reference signal: the DSP requires this signal from the frac-N/reference assembly for proper operation. This signal is routed on the backplane board. Make sure that the frac-N/reference assembly is pushed all the way in and making good contact with the backplane. Measure the 5 MHz signal at J6-C24 on the backplane board with a scope. If the signal is present, remove the CPU board and the shield over the DSP chip (on the right side of the board). Make sure that the TMS 320C25 microprocessor is properly seated in its socket. If the problem persists, refer to "Detailed Troubleshooting" to check the DSP, or replace the CPU board.

No 5 MHz signal on backplane: check the reference board. If an external reference signal is used, make sure it's a 10 MHz reference with a level of at least -5 dBm.

If the internal 10 MHz reference is being used, check the output at A3J3 to verify that the crystal oscillator is working. If the 10 MHz signal is not present, replace the A3 frac-N/reference assembly.

Other Power-Up Problems

The power-up sequence can also go wrong if there is a problem with the SRAM. These problems can have many symptoms, since the symptom will depend on where the instrument was in its power-up sequence when the bad data was encountered. Try clearing the SRAM (see previous section for instructions). If the problem persists, the DRAM is probably bad and the CPU board needs to be replaced.

Front Panel Problems

If the front panel keyboard is not responding properly, remove the front panel and make sure the ribbon cable is properly connected between the FP and the CPU.

Inspect the keypad and the PC board. Replace it if it's defective. The RPG can be replaced separately.

If everything else is okay, replace the CPU board.

TROUBLESHOOTING SOURCE GROUP PROBLEMS

This group includes the fractional-N/reference and source boards. Main problems are likely to be these:

- Phase lock lost
- Power output problems
- Source spurs

Output power check: connect a power meter, oscilloscope, or spectrum analyzer to the reflection port. Set analyzer to CW frequency of 300 kHz. Change power level and see if output power changes correctly. Repeat at a couple more frequencies, e.g. 1 MHz and 50 MHz.

No source output or noisy -20 dB trace: the source may be disconnected from the receiver. Check the cable connections between the source and receiver (torque to 8 in-lbs). If the problem persists, go to "Phase Lock Problems" below.

Signal not steady: (i.e. appears unlocked), or if the frequency doesn't change properly, go to "Phase Lock Problems." If the signal appears okay but the power levels are incorrect, go to "Power Problems." If spur problems are suspected, go to "Spurious Signals." Otherwise, proceed to the "Receiver Troubleshooting."

Phase Lock Problems

There are 3 phase lock loops on the source board: RF1, RF2, and source LO. As you can see from the overall block diagram, the source LO is mixed with the RF1 signal to produce the source RF output. It is also mixed with the RF2 signal to produce the receiver LO output.

Since both the RF1 and RF2 loops use the 10 MHz reference signal from the A3 frac-N/reference board, verify that signal first.

Verify 10 MHz Reference: remove the handles and front panel. Connect an oscilloscope or frequency counter to A3J3 (connector on the right) to measure the 10 MHz output from the frac-N/reference board.

Note



The 10 MHz signal is DC coupled, although the DC offset is small. A blocking capacitor is recommended if you want to use a spectrum analyzer. The signal should measure 10 MHz \pm 50 Hz.

- Signal correct: continue with "Verify Frac-N Output" below.

- Signal present but not accurate: perform the “Frequency Accuracy Adjustment” procedure in the Adjustments section of this manual.
- No signal found: verify that external reference has not been selected by pressing the **MENU** key and making sure that **Ext Ref on OFF** is displayed. Replace the frac-N/reference board, or refer to “Detailed Troubleshooting” to continue.

Verify Frac-N Output: set the analyzer to the CW frequencies in the table below, and check the fractional-N output at A3J1 (connector on the left).

Source Frequency	Frac-N Frequency
300 kHz	36.567 MHz
100 MHz	38.125 MHz
500 MHz	44.375 MHz
1.3 GHz	56.875 MHz

- Frac-N output OK: replace source board.
- Frac-N output not OK: press **MENU** **Spur Avolt** and make sure dither is OFF, since the frequencies will be different for dither ON. Remove the frac-N/reference assembly and check all cables. Perform the “Fractional-N VCO Adjustment” (see the “Adjustments” section of this manual). If problem persists, replace the frac-N/reference assembly.

Source Power Problems

Perform the “LO Power Correction” and “Source Power Correction” procedures in the “Adjustments” section of this manual. Measure the RF output signal directly out of the source board at A4J4 to verify problems above 0 dBm. (Note that if the analyzer has a step attenuator, the power output from A4J4 will be offset, since the adjustments were done with the attenuator in the signal path.) If the output is correct when measured directly from A4J4, go to Receiver troubleshooting. Otherwise, replace the source assembly.

Spurious Signals

Perform the “Spurious Signals” test procedure in the Performance Tests section of this manual. If the test fails, perform the “LO Power Correction” and “Fractional-N Spur Adjustment” procedures in the “Adjustments” section of the manual, then run the “Spurious Signals” test again.

Check RF at A4J4: connect a spectrum analyzer to the source RF output at A4J4. Set the 8711 to a series of CW frequencies, e.g. 10 MHz, 500 MHz, 1 GHz, and use the SA to check for harmonics and other spurs. The specification for harmonics is < -20 dBc below 1 MHz and < -30 dBc above 1 MHz. Non-harmonic spurious signals are not specified, but typical values are the same as for harmonics. Connect the spectrum analyzer to the receiver LO output at A4J1 and repeat. If everything meets the specifications, go to the “Troubleshooting Receiver Problems” section.

Spurs in source output only: replace the source assembly.

Spurs in receiver output only: replace the source assembly.

Spurs in source and receiver outputs: the problem may be due to spurs in the 10 MHz or frac-N inputs to the source. Fractional-N spurs are not specified, so use the “Fractional-N Spur Adjustment” to improve the spur performance, but do not replace the frac-N board unless these spurs cause the HP 8711 to fail its harmonics specifications.

Check 10 MHz at A3J3: use an oscilloscope. Look for a 2V 10 MHz pulse. A spectrum analyzer should be used only if a blocking capacitor is also used, since the 10 MHz output is DC coupled. If the 10 MHz signal has spurs, replace the frac-N/reference board. Otherwise replace the source.

TROUBLESHOOTING RECEIVER PROBLEMS

Connect a cable between the reflection and transmission ports, then press **PRESET**. The display should show a flat trace at about 0 dB. Press **CHAN1 Reflection**. The display should resemble Figure 4-3 below, although the exact pattern and magnitude of the ripples will depend on the cable being used.

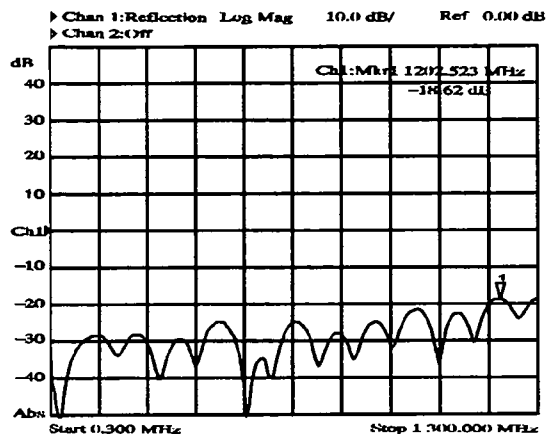

Figure 4-2. Reflection Measurement with Through Cable

Receiver troubleshooting is organized by these symptoms:

- Trace at ± 200 dB
- Random Noise Trace
- Spurs in Data Trace
- Incorrect Data
- Power Problems

Trace at ± 200 dB

A flat trace at ± 200 dB indicates that the DSP is getting no data (or zero data.) Make sure that the receiver and CPU boards are making proper connections to the backplane. The problem is most likely either in the ADCs on the receiver board, or the DSP circuitry on the CPU board.

Test the DSP circuitry: locate J32, an 8x3 jumper just above the DSP shield. Put the jumper in the “TEST” position as shown on the board. This replaces the receiver’s ADC clock and data signals with a clock signal and fake data generated on the CPU board. The instrument should power up normally. Observe the CRT.

- Random noise data trace around 0 dB: replace the receiver or go to “Detailed Troubleshooting.”

- No random noise data trace around 0 dB: replace the CPU.

Random Noise Trace

If the trace displays random noise, check the cable connections between the source and receiver and tighten if necessary. Press **CHAN 1**, **Detection Options**, **Narrowband Internal**, **B** and observe the R input trace on the CRT. Press **A**, with the reflection port open, and observe the trace. Press **B**, with a through cable connected between the reflection and transmission ports. Observe the trace. If all three show noise floor traces (noise at or below -80 dB), the receiver LO is probably bad.

Verify receiver LO output from source at A4J1: set the analyzer to any CW frequency. The receiver LO signal should be 27.778 kHz away from the CW source RF frequency. If this signal is not present, or if the frequency is significantly wrong, replace the source board. (Note that the fractional-N and 10 MHz inputs to the source board are assumed to be okay because the RF OUT signal is okay.) If the receiver LO signal is okay, replace the receiver board.

Spurs in the Data Trace

This section addresses repeatable or predictable spurs and jumps in the data trace, rather than random noise. Use a spectrum analyzer or power meter to check the output of the source at the reflection port to see if the spurs are in the RF output signal. If they are, go back to “Source Group Troubleshooting.”

Perform the “Switched Gain Correction” adjustment (in the “Adjustments” section of this manual). If the problem persists, replace the receiver board.

Incorrect Data

Check adapters, cables, and test port connectors for damage. Gage the test port connectors. Make sure that the cables between the source and receiver boards are properly connected.

Perform the following receiver corrections found in the “Adjustments” section of this manual, as indicated by where the data problems occur. If the problem is in both narrowband and broadband mode, refer to the “Adjustments” section to determine the proper order for performing the tests.

Narrowband mode problems

- Switched Gain Correction
- B Amplitude Correction
- Transmission Correction
- Reflection Correction

Broadband mode problems

- Switched Gain Correction
- External Detector Correction
- R* Amplitude Correction
- R* Frequency Response Correction
- B* Amplitude Correction

If data seems to drift, check the uncorrected performance of the analyzer. Connect a load to the reflection port.

Press **PRESET** **CHAN 1** **Reflection** **SYSTEM OPTIONS** **Service** **Meas Cal Options** **Meas Cal Off** **MARKER** **Marker Search** **Mkr--Max**. The marker value should be less than -15 dB. Remove the load and connect a through cable between the reflection and transmission ports. Press **Mkr--Max**. The marker value should be less than -12 dB. If these are bad, replace the receiver assembly. Test port cable can also cause drift.

If data is okay with just a through cable connected (after preset) but bad in an application, check for the following:

Verify that you are looking at the expected measurement; especially check:

- Data vs. memory or data/memory display
- Channel 1 vs. channel 2 data trace
- Channel 1 vs. channel 2 y-axis labels (when both channels are on)
- “Rel” vs. “Abs” y-axis scale
- System bandwidth
- Narrowband vs. broadband mode

Make sure the span is not too narrow. This may cause interpolation errors with the default or full band calibrations. Perform a user-defined calibration at the desired frequency range.

Receiver Power Problems

Check all cables and cable connections on the receiver board; tighten if necessary. If the problem is caused by a power hole, try moving the cables and see if the power hole moves or disappears. If it does, you probably have a bad cable.

If the analyzer has a step attenuator and the problem is in the <0 dBm range only, replace the step attenuator assembly. Otherwise, replace the receiver board.

Detailed Troubleshooting

This section provides more detailed troubleshooting procedures for use in confirming problems or isolating failures to either functional blocks on the board or to the component level. Many of the procedures require a service extender board, part of the HP 8711 service tool kit. Half of the extender attaches to the backplane, while the ribbon cables and second half of the extender allow you to plug a board into the backplane while it is on top of the analyzer. Be sure to use an antistatic mat on top of the analyzer to prevent the board from shorting on the analyzer's cabinet.

Refer to the HP 8711 Schematic Package for component location diagrams, schematics, and parts lists.

DIGITAL GROUP

To confirm video circuitry problems: remove the CPU and place it on top of an antistatic mat on top of the analyzer. Use a service extender board to turn it on while it is outside the analyzer. Turn the analyzer on and make sure the green "Video On" LED next to the display ribbon cable connector is on. Check these signals:

- HSYNC signal at TP12: 24.1 kHz TTL signal
- VSYNC signal at TP13: 60 Hz TTL signal

If either of these is not normal, replace the CPU board.

To check the DSP (digital signal processor): locate J32 on the CPU board, an 8x3 jumper just above the DSP shield. Put the jumper in the "TEST" position as shown on the board. This replaces the 5 MHz clock from the frac-N with a 5 MHz clock derived from the DSP's 40 MHz clock, and provides fake data to replace the receiver's ADC data.

The instrument should power up normally and display a trace with random noise data centered around 0 dB.

- Trace as described above: the DSP circuitry is OK.

Check the frac-N/reference for a problem with the 5 MHz clock.
Check the receiver board for ADC problems.

- Trace not as described above:

Check for the DSP's 40 MHz clock signal at TP17. If this isn't present, replace Y3. Otherwise the problem is most likely in the DSP chip (U97) or control circuitry.

SOURCE GROUP

To troubleshoot the 10 MHz reference signal: if a service extender board is available, put the frac-N/reference board on the extender.

- Verify power supplies: -5V at TP1 and TP2.
- Check for the internal 10 MHz signal at TP7 and U5 pin 8. If this is not found, replace the frac-N/reference board or U5, the 10 MHz clock.

- Check TP8 for a 10 MHz signal. If this is present, Q1 is most likely bad. Replace the frac-N/reference board, or refer to the HP 8711 Schematic Package to troubleshoot further.

To troubleshoot the frac-N board: the fractional-N board is also used in the HP 3325A. Refer to the HP 3325A Operating and Service Manual, HP part number 03325-90002, for more detailed troubleshooting information.

RECEIVER GROUP

To confirm an ADC problem when trace is at ± 200 dB: check for activity at the following pins on the receiver's backplane connector.

Pin Number	Signal
C27	ADC_DAT1
A27	ADC_CLK1
C26	ADC_DAT2
A26	ADC_CLK2

If these signals are not present, replace the receiver assembly or refer to the HP 8711 Schematic Package for details.

Service Key Menu

INTRODUCTION

This chapter describes the functions of the service key menus. These menus are used to test, verify, adjust, control and troubleshoot the instrument. They are divided into two groups: internal diagnostics and adjustment; and service functions. Internal diagnostics and adjustments include self-tests and adjustment tests. The service functions allow you to put the instrument into states to help with troubleshooting.

The service menu is accessed by pressing **SYSTEM OPTIONS** **Service**. Refer to Figures 5-1 and 5-2 for the service key menu maps.

Also included in this chapter are miscellaneous service functions and HP-IB commands. Procedures to clear nonvolatile memory (SRAM) and to load firmware are included in the "Miscellaneous Service Functions" section. Equivalent HP-IB commands for some of the service menu keystrokes are found in the "HP-IB Command Reference for Service" section.

INTERNAL DIAGNOSTICS AND ADJUSTMENTS SUMMARY

The internal diagnostics menus are shown in Figure 5-1 and are described in the following paragraphs. The internal diagnostics key is **Tests and Adjustments**. This key is accessed by pressing **SYSTEM OPTIONS** **Service**.

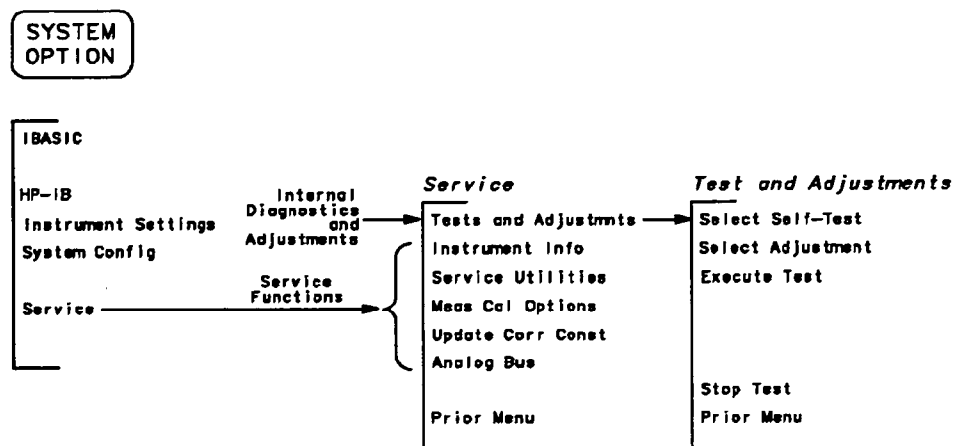

sd83a

Figure 5-1. Internal Diagnostics and Adjustments Menu.

INSTRUMENT SETTINGS MENU

This is not one of the service key menus but appears here as a reminder that it can provide information useful for servicing the analyzer. This menu is documented in the operating manual: see (1) **SYSTEM OPTIONS** in Chapter 7, "Reference" or (2) look up any of the individual instrument settings keys in "Reference".

TESTS AND ADJUSTMENTS MENU

Select Self-Test : Allows the user to select a diagnostic self test. Tests may be selected by entering the number of the test with the keypad, or using the RPG or up/down arrow keys to scroll through the list of tests. The number, description, and test status of the currently selected test are shown. Possible test status notations are: "PASSED," "FAILED" and "NOT DONE." See "Self-tests" for a listing of all the tests and their descriptions. If any test fails, refer to Chapter 4, "Troubleshooting," in this manual.

Some tests are run during power-up and the results of these tests will be displayed when the test is selected. These tests cannot be executed from this menu.

Select Adjustment : Allows the user to select an adjustment test. Tests are listed in the order that they should be performed. The one exception to this rule is that adjustment number 110 should be performed before performing adjustment number 109. To select a test, use the numeric keypad to enter the test number, or use the RPG or up/down arrow keys to scroll through the list. The number, description, and test status of the currently selected test are shown. Possible test status notations are: "PASSED," "FAILED" and "NOT DONE." See "Adjustments" for a listing of the adjustments and their descriptions.

Executes Test : Executes the selected test if that test is currently implemented.

Stop Test : This stops any test that is currently running.

Prior Menu : Goes back to the main service menu.

SELF-TESTS

Internal tests in the HP 8711A are divided into two categories: self-tests and adjustment tests. Self-tests are diagnostic tests which can be used in troubleshooting the analyzer. Only the ones marked with an asterisk (*) below are executed during the power-up sequence. The pass/fail status of these tests can be checked by scrolling through the list of self-tests. Also, if any test fails during power-up, the number of the first test to fail will be displayed on the "Test Results" LED which is visible from the rear panel. The other tests run only when selected from the service menus.

Note



There are two LEDs to the left of the seven-segment "Test Results" LED on the rear panel of the HP 8711A. The red LED is on for self-tests 1 through 9, and the green LED is on for tests 10 through 19. If all tests pass, the green LED will be on, and the red LED and the seven-segment LED will be off.

Test#	Test Name	Description
*1	680x0 Processor	Executes internal tests of 68020 main CPU. Checks all registers. Checks logic, math, shift/rotate, and bit manipulation instructions.
*2	Boot ROM Checksum	Checksum of boot ROM to verify boot ROM firmware code.
*3	Main ROM Checksum	Checksum of flash EPROM to check main firmware.

*Test runs during power-up

Test#	Test Name	Description
*4	Main DRAM	Writes a series of test patterns to the main DRAM and reads them back. Checks size of main DRAM.
*5	SIMM DRAM	Tests SIMM DRAM by writing to the DRAM and then reading the data back. Checks size of SIMM DRAM.
*6	340x0 GSP Processor	Performs a test of the TMS 34010 graphics system processor. Tests the display video RAM (VRAM).
*7	GSP Video	Tests the video circuitry.
8	(Not used)	This test number is not used because the test status LED powers up with the number "8" as the default. If there is a problem with the 68020 CPU, this "8" will remain displayed on the LED.
*9	320C25 Program SRAM	Checks the program SRAM used by the TMS 320C25 digital signal processor.
*10	320C25 DSP Processor	Tests the TMS 320C25 digital signal processor.
11	68020 & 320C25 Communication	Not implemented.
*12	Backplane Bus	Tests the ability of the 68020 to access the other boards through the backplane assembly.
*13	Non-volatile SRAM	Tests the integrity of the contents of battery-backed SRAM. Detects loss of power to the SRAM.
14	Digital IF Control	Not implemented.
15	CPU Support Circuitry	Tests various circuits that are required for the main processor (68020) to operate. Tests 68901 MFP chip (timers, interrupts). Attempts to clear and disable all interrupts. Tests each interrupt signal to the 68020 to make sure that none of them are asserted.
16	Analog Bus	Tests the analog bus control circuitry and +5V and EPROM Vpp on the CPU board.
17	Real Time Clock	Tests the real time clock and tries to access registers on the chip.
*18	Front Panel Interface	Tests the front panel control processor. Tries to access registers on the chip.
*19	Floppy Disk Controller	Tests the floppy disk controller chip. Tries to access registers on the chip. Writes commands to the chip, and verifies correct response. Also steps the floppy disk drive's head from track 0 to 9, and back to 0, to test the ability to find track 0.
*20	HP-IB Interface	Tests the HP-IB interface circuitry. Tries to access registers on the chip. Writes commands to the chip, and verifies correct response.
*21	RS-232 Interface	Tests the RS-232 DUART chip. Tries to access registers on the chip. Checks for missing clock input to the chip.
*22	DIN Keyboard Interface	Tests the DIN keyboard control processor. Tries to access registers on the chip.
*23	Centronics Interface	Tests the Centronics interface circuitry. Writes to three main printer control output lines, and reads them back.

*Test runs during power-up

Test#	Test Name	Description
24	Front Panel Key	Prompts user to press any keys and displays information on the key pressed. Press <input type="button" value="PRESET"/> three times to exit.
25	Erase Non-Volatile SRAM	Tests all locations of battery-backed SRAM by writing zeroes. This erases existing data.
26	Source PLL Lock	Not implemented.
27	X External Detector ID	Not implemented.
28	Y External Detector ID	Not implemented.
29	RS-232 Port	Prompts user to connect a printer or terminal, and then sends characters to the port.
30	Centronics Port	Prompts user to connect a printer, and then sends characters to the port.
31	DIN Keyboard Port	Prompts user to connect a DIN keyboard. Displays feedback on detected key presses.
32	HP-IB Port	Prompts user to disconnect HP-IB cable. Tests HP-IB hardware. Prompts user to connect a printer, and then sends characters to the port.
33	Test TTL Pass/Fail Bit Test	Prompts user to disconnect cable and then tests the hardware. Prompts user to ground the bit and then tests the hardware.
34	Test TTL User Bit Test	Prompts user to disconnect cable and then tests the hardware. Prompts user to ground the bit and then tests the hardware.

ADJUSTMENTS

Adjustment tests generate correction constants (CCs) which compensate for the hardware performance of the analyzer. Correction constants are stored in flash EPROM along with the firmware. The data is copied to RAM during power-up. Running an adjustment test modifies the data in RAM, but it does not alter the data in EPROM. To store the new CCs into EPROM, you need to store the CCs to disk, clear the EPROM by reloading the firmware, recall the CCs from disk back into the RAM, and then store the CCs into EPROM.

Refer to Chapter 3, "Adjustments," for details on how to perform these tests.

Test#	Title	Comments
100	Set Serial Number	Not implemented; serial numbers can only be set over HP-IB.
101	LO Power	Sets a DAC that varies the receiver LO output from the source. This ensures that the receiver mixers are getting the correct power level.
102	Switched Gain	Sets the low and high gain corrections for the receiver, which are needed for accuracy at low input power levels.
103	Ext Det Gain	The external X and Y detectors convert the detected power level into a voltage for the HP 8711 receiver. In this adjustment, known voltages are applied to the detector input ports. The analyzer then generates correction constants for the receiver to use in interpreting the detector voltage level.

Test#	Title	Comments
104	ALC Correction	Source power correction. Generates power correction arrays for both the ALC and step attenuator (if installed).
105	B Ch Abs	B amplitude correction. Corrects B narrowband input so that it reads 0 dBm properly.
106	B/R Vector	Transmission correction. Performs transmission cal to correct B/R to read 0 dB.
107	One Port	Reflection correction. Performs one-port cal to correct for narrowband reflection (A/R) measurements.
108	R Scalar Pow	R* amplitude correction. Generates absolute power lookup table for the R* input at 30 MHz.
109	B Scalar Pow	B* amplitude correction. Generates absolute power correction table for the broadband B* input at 30 MHz. The B* input power is varied from -54 to +18 dBm in 2 dB steps for this test. An external controller is required to run this test.
110	R Scalar Freq	R* frequency response correction. Generates frequency response correction for the broadband R* input.
111	Aux Input	Auxiliary input correction. Corrects for offset and gain of the aux input circuitry. aux input circuitry.

SERVICE MODES SUMMARY

The service modes menus are shown in Figure 5-2 and described in the following paragraphs. The service modes softkeys are: **Instrument Info**, **Service Utilities**, **Meas Cal Options**, **Updates Corr Const** and **Analog Bus**.

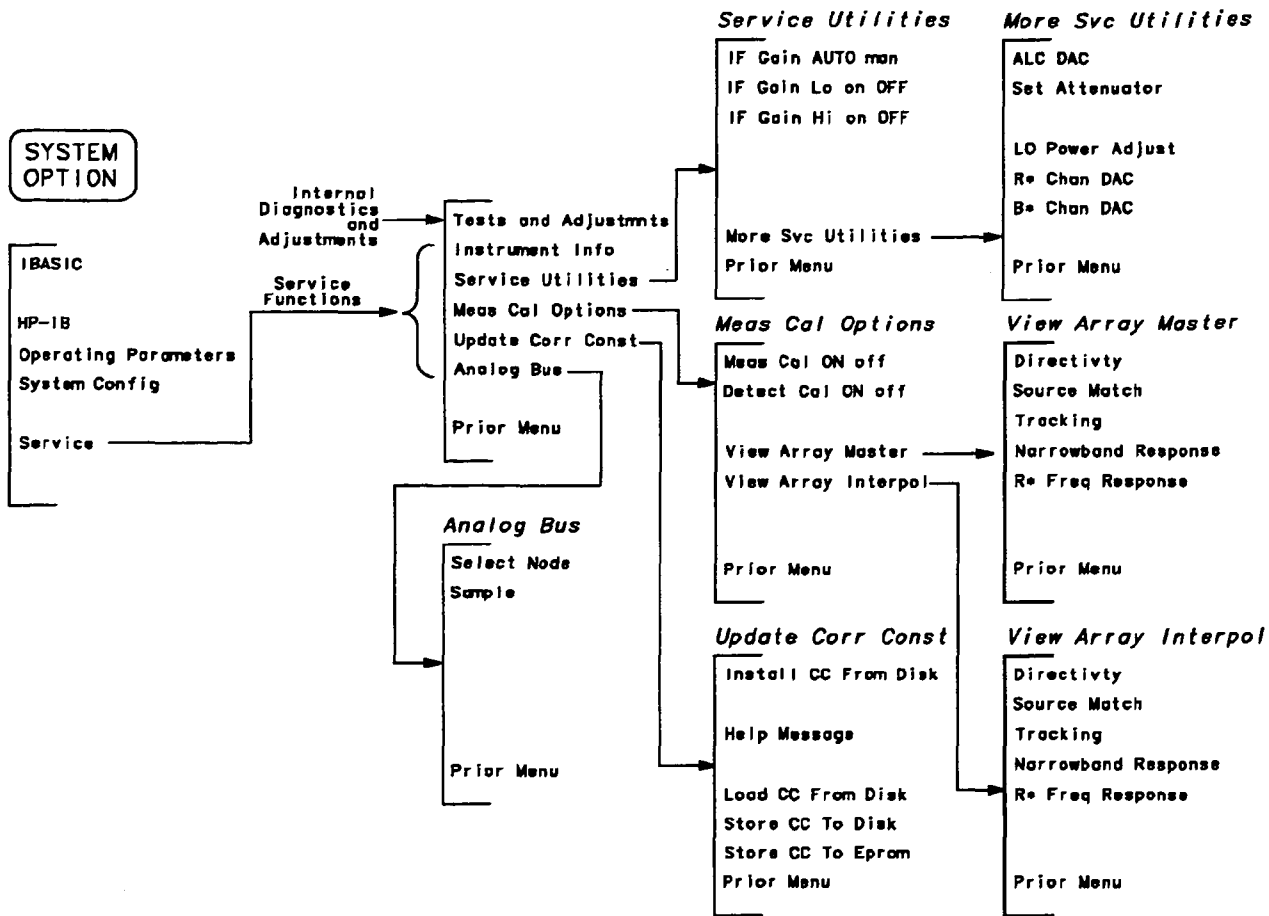

sd64a

Figure 5-2. Service Functions Menus

INSTRUMENT INFO

Displays a window with the following information:

- Instrument model and firmware revision
- Boot ROM version
- Instrument serial number
- Installed options
- System impedance
- Installed memory (DRAM)

SERVICE UTILITIES MENU

This menu allows manual control of several sections of the source and receiver boards. This can be a helpful tool in troubleshooting these circuits.

IF Gain AUTO man : Allows the user to have manual control over the IF gain amplifiers in the receiver.
IF Gain Auto : Overrides the settings of the other IF gain keys. This is helpful for troubleshooting problems with the receiver board's IF gain amplifiers. In AUTO mode, the instrument autoranges the IF amplifiers to achieve optimal signal/noise at ADC. In manual mode, the user sets the gain stages on or off using the following keys:

IF Gain Lo ON off : Only active when **IF Gain MAN** has enabled manual control. The low IF "gain" does not have gain. The circuit has a step attenuator which is normally on, and it is switched off when "gain" is needed. This key allows the user to turn the low IF gain on or off, by switching the attenuation off or on respectively.

IF Gain Hi on OFF : Only active when **IF Gain MAN** has enabled manual control. Allows user to turn the high IF gain amplifier circuit on or off. When IF gain is being controlled automatically, the high IF gain is not used for narrowband measurements.

Note



The receiver can be compressed if high powers are applied with the switched gain set to "on." The switched gain cal removes offsets between the different gain states, so the trace level should not be changed when the gain is turned on.

More Svc Utilities : Goes to the more service utilities menu, which allows the user to manually control the ALC DAC, step attenuator, LO power and the autozero DACs for the R* and B* inputs.

Prior Menu : Goes back to the service menu.

MORE SVC UTILITIES MENU

ALC DAC : Allows manual adjustment of the Automatic Level Control (ALC) DAC, which controls the source output ("RF out" connector) power level. Disables the ALC power calibration until a power level is entered using the "Power" menu.

Set Attenuator : Allows manual control of the step attenuator if one is installed.

LO Power Adjust : Allows manual adjustment of the DAC which controls the LO output power. The LO power is used by the receiver board.

R* Chan DAC : Allows manual adjustment of the DAC used to set the offset for the R* and X channel chopper, used in zeroing the R* detector. Analog bus node 14 can be used to check the voltage output of the DAC. Range = 0 - 4095. The number 2048 corresponds to near zero offset.

B* Chan DAC : Allows manual adjustment of the DAC used to set the offset for the B* and Y channel chopper, used in zeroing the B* detector. Analog bus node 13 can be used to check the voltage output of the DAC. Range = 0 - 4095. The number 2048 corresponds to near zero offset.

Prior Menu : Goes back to the service utilities menu.

MEAS CAL OPTIONS MENU

The HP 8711 uses array of calibration data to improve the measurements made by the hardware. This menu allow the user to disable the calibration, and view the calibration data arrays.

Meas Cal ON off : Determines whether cal arrays are used in processing data. **Meas Cal OFF** will turn off both user-performed cals and the default factory cal. This includes transmission, reflection, and frequency response cal arrays (both broadband and narrowband). This function provides a way to examine the uncorrected performance of the hardware in the instrument.

Delect Cal ON off : Allows the user to turn off the power cal for both the internal and external broadband detectors.

View Array Master : Selects the master (uninterpolated) cal arrays from the master to be displayed. These are the cal arrays from the currently active calibration (default, full band, or user-defined). Leads to the view array master menu.

View Array Interpol : Selects the interpolated cal arrays from the master to be displayed. These are the cal arrays from the currently active calibration (default, full band, or user-defined). Leads to the view array interpol menu.

Prior Menu : Goes back to the main service menu.

VIEW ARRAY MASTER MENU VIEW ARRAY INTERPOL MENU

These keys allow you to view the actual calibration data arrays that are currently in use. The arrays are copied into a memory trace for easy analysis. This allows you to scale them, and use markers to read out actual values.

Note All calibrations are 801 points.



Directivity : Displays the directivity cal array as a memory trace.

Source Match : Displays the source match cal array as a memory trace.

Tracking : Displays the tracking (narrowband frequency response for reflection) cal array as a memory trace.

Narrowband Response : Displays the narrowband transmission frequency response cal array as a memory trace.

R* Freq Response : Displays the broadband R* frequency response cal array as a memory trace.

Restore Data Disp : Presets the instrument.

Prior Menu : Goes back to the meas cal options menu.

UPDATE CORR CONST MENU

For a description of when and how to use these keys, refer to "Storing and Recalling Correction Constants" in Chapter 3, "Adjustments."

Install CC from Disk : Loads permanent copy of CC data from disk to EPROM. This key combines the functions of **Load CC from Disk** and **Store CC to EPROM** .

Help Menu : Displays a banner which describes the keys of this menu.

Load CC from Disk : This copies the contents of the correction constant file named "CC_data" from the internal floppy disk drive into RAM. The user cannot select an alternate disk drive. It allows the user to copy a partially modified set of data into RAM and then continue with the rest of the adjustments.

Store CC to Disk : At power-up, correction constants are copied from the flash EPROM to a RAM buffer. Any changes to the CCs are made to the buffer only. Pressing this key creates a disk file named “CC_data” that contains the correction constants from the buffer. This file is always written to the internal disk drive, regardless of the disk drive selected using the save/recall functions. The file will be written over any existing file with the same name.

Store CC to EPROM : This alters the nonvolatile correction constants stored in the analyzer. The flash EPROM must be cleared first via firmware update. If not, the user is told to store the CCs to disk and update the firmware first. If the flash EPROM is clear, the correction constant data is transferred from the buffer into the EPROM. To update or load firmware, refer to “Loading Firmware” later in this chapter.

Note



This copies *all* the adjustment data. If an adjustment test has not been done, the default values are put in EPROM and the only way to replace them with real adjustment data is to do the adjustment, **Store CC to Disk**, reload the firmware, **Load CC to Disk**, and **Store CC to EPROM**.

Prior Menu Goes back to the service menu.

ANALOG BUS MENU

The HP 8711 has an analog bus that can be used to troubleshoot hardware problems on some of the boards in the instrument. This is done by sampling analog bus nodes, which provide measurements at selected points on the boards. Nominal values for each node are provided in the following table.

Select Node : Allows the user to select an analog bus node to be measured. The currently selected node description and number are displayed. A node may be selected by using the keypad to enter the number, or by using the RPG or up/down arrows to scroll through the list.

Sample : Triggers a data measurement of the selected analog bus node.

Prior Menu : Goes back to the service menu.

ANALOG BUS NODES

Number	Name	Description
1	+47 Volts	+47V power supply on the source board (+47A on the schematic). Normal value: 44V to 50V
2	RF 1 Tune	VCO tuning voltage for the RF1 phase lock loop on the source board (RF1_TUNE on the schematic). Value varies with the source frequency setting. Normal values are 6 to 10 volts. A value higher than about 11.5V may indicate a saturated op amp.
3	LO Integrator	Output of integrator in the source LO loop (LO_INT on the schematic). Voltage decreases as source frequency increases; normal values are -2.0 to +10.0 volts.
4	Offset Tune	VCO tuning voltage for the RF2 phase lock loop on the source board (OFFSET_TUNE on the schematic). Value varies with the source frequency setting. Normal values are 6 to 10 volts. A value higher than about 11.5V may indicate a saturated op amp.
5	Output Amp Temp	Shows the temperature at the output amplifier on the source board (OUTPUT_AMP_TEMP on the schematic). Normal values are 30 to 45 degrees Celsius.

Number	Name	Description
6	ALC Log	ALC log amp output on the source board (ALC_LOG on the schematic). Value depends on the source power level. Normal values are -1.75 to -0.5 volts.
7	ALC PIN	Voltage to ALC PIN modulator on the source board. This value increases as the source power increases. Normal values range from 3.0 to 10.5 volts.
8	+5V on RCVR	+5V power supply on the receiver board. Normal values are 4.5 to 5.5 volts.
9	+15V on RCVR	+15V power supply on the receiver board. Normal values are 13.5 to 16.5 volts.
10	-15V on RCVR	-15V power supply on the receiver board. Normal values are -16.5 to -13.5 volts.
11	X Det Temperature	X detector temperature (ITEMPX on the receiver schematic). A typical value is 30 degrees Celsius when a detector is connected. If no detector is connected, the typical value is around 0 degrees Celsius.
12	Y Det Temperature	Y detector temperature (ITEMPY on the receiver schematic). A typical value is 30 degrees Celsius when a detector is connected. If no detector is connected, the typical value is around 0 degrees Celsius.
13	B*/Y Autozero	Offset used for the B chopper on the receiver board (BOFFSET on the schematic). The voltage varies depending on the value of the B* DAC, which can be changed using the more service utilities menu. Typical values are -12 to +12 volts.
14	R*/X Autozero	Offset used for the R chopper on the receiver board (ROFFSET on the schematic). The voltage varies depending on the value of the R* DAC, which can be changed using the more service utilities menu. Typical values are -12 to +12 volts.
15	B* Detector Temp	Temperature of B* internal detector on the receiver board (BTEMP on the schematic). Typical values are 20 to 60 degrees Celsius; this will depend on the ambient temperature.
16	+5V on CPU	+5V power supply on the CPU board. Normal values are 4.5 to 5.5 volts.
17	+12V Flash Voltage	+12V Vpp supply for writing to the flash EPROM on the CPU board. This voltage is normally OFF, so the ABUS value should be less than 2.5V. The "on" voltage level is checked during the power-up tests, and an error message is displayed if the level is incorrect.
18	CPU Temp	Temperature sensor on CPU board (CPU_TEMP on the schematic). Typical values are 30 to 60 degrees Celsius; this will depend partly on the ambient temperature.

MISCELLANEOUS SERVICE FUNCTIONS

Clearing Nonvolatile Memory (SRAM)

This is also referred to as “zeroing” the nonvolatile SRAM, because the procedure causes the analyzer to write zeroes into the nonvolatile SRAM locations in memory. Note that this will erase any files saved to internal memory (RAM disk).

To clear the memory, turn on the HP 8711. While the instrument is running through its self-tests, press the **PRESET** key a few times. The analyzer will finish the main CPU tests, then pause with a message asking if the user wants to zero the SRAM. Press the **BEGIN** key to clear the memory. Press softkey #8 (bottom softkey) if you want to continue without clearing the memory.

Correction Constant Procedures

Refer to “Storing and Recalling Correction Constants” in Chapter 3, “Adjustments”, to perform these tasks:

- To store correction constants to disk or EPROM
- To load correction constants to RAM from disk.

Upgrading Firmware

To upgrade your analyzer's firmware you need two disks:

- a firmware disk
- a correction constant (CC) disk

Both disks are necessary because





- Correction constants are stored in EPROM with firmware,
- The old firmware must be erased before the new firmware is stored, and
- EPROM can only be erased all at once (not partially).

A firmware disk is shipped with each HP 8711. New firmware disks are released periodically as improvements are made. You should always keep at least one copy of firmware in a safe place because you cannot create a firmware disk yourself. See "Replaceable Parts," chapter 7, for the HP part number of the firmware disk.

You can use the correction constants disk shipped with the analyzer if (1) no parts have been replaced in the instrument and (2) no adjustments have been made. If, however, changes have been made, you must use a disk with the current correction constants. If such a disk is not available, follow the procedure below to make a current correction constants disk.

Making a Current Correction Constants Disk (Optional)

Note: for details on storing and recalling correction constants, see "Storing and Recalling Correction Constants" at the end of chapter 3, "Adjustments."

1. Insert a formatted disk into the internal disk drive. (If needed, format the disk with the file utilities menu under ).
2. Press    .
3. Remove the correction constants disk.

Upgrading the Firmware

1. Insert the firmware disk and cycle power: the analyzer indicates that it detects a firmware disk and is about to install the new firmware.
2. Press  when prompted: the firmware takes about 5 minutes to load.
3. Remove the firmware disk and cycle the power again: the analyzer indicates that no correction constants are installed.
4. Insert the correction constants disk.

5. Press **SYSTEM OPTIONS** **Service** **Update Corr Const** **Load CC from Disk** to load the correction constants into RAM.

Note: With some firmware revisions, you may see a warning message indicating that the CC just loaded were made with a different firmware revision. In this case, it may be necessary to perform one or more additional adjustments. Press **SYSTEM OPTIONS** **Service** **Test and Adjustments** **Select Adjustment** . Cycle through the adjustments, note any that are "NOT DONE." Perform these before proceeding with the next step. Note that adjustment #100 will always indicate "NOT DONE" and should not be performed.

6. Press **Stors CC to EPROM** . When done, cycle the power in order for the new correction constants to take effect.

HP-IB COMMAND REFERENCE FOR SERVICE

Some of the service menu keystrokes have equivalent remote HP-IB commands. The HP 8711 uses the SCPI programming language. For more information about SCPI and HP-IB, refer to the “HP-IB Programming” section of the Operating and Programming manual. Service-related SCPI commands are listed in two sections below.

Syntax Summary

The following conventions are used when SCPI commands are being described:

- Angle brackets (< >) are used to enclose required parameters within a command or query. The definition of the variable is usually explained in the accompanying text.
- Square brackets ([]) are used to enclose implied or optional parameters within a command or query.
- UPPERlower case characters are used to indicate the short form (upper-case) of a given mnemonic. The remaining (lower-case) letters are the rest of the long form mnemonic. Either the short form or the long form may be used.

Softkey SCPI Commands

This section lists the service menu keys in the order they appear on the menu map. (See Figures 5-1 and 5-2.) Each softkey is shown with its corresponding short form SCPI command.

Some SCPI commands do not correspond directly to a softkey. These are listed in the alphabetical command summary following this list, which also lists the long form of each SCPI command.

Keystrokes	SCPI Command
Tests and Adjustments Menu	
Select Self-Test	TEST:SEL <num>
Select Adjustment	TEST:SEL <num>
Execute Test	TEST:STAT RUN
Stop Test	TEST:STAT STOP
Meas Cal Options Menu	
Meas Cal ON/off	SENS[1 2]:CORR[:STAT] <ON 1 OFF 0>
Update Corr Const Menu	
Store CC to Disk	DIAG:CCON:STOR:DISK
Store CC to EPROM	DIAG:CCON:STOR:EEPR
Load CC from Disk	DIAG:CCON:LOAD

Alphabetical SCPI Command Summary

This section contains the service-related HP-IB mnemonics recognized by the HP 8711A with a short description of each. All commands have a query form unless specified in the "Form" column as command only or query only. To change a command into a query, add a "?".

The "Form" column also gives the parameter type returned by the instrument in response to a query. NR1 (integers), NR2 (floating point numbers with explicit decimal point), and NR3 (floating point number in scientific notation) refer to different types of numeric data. CHAR (character data) and STRING (string data, enclosed in quotes) are also used to describe response types. These parameter types are described in the "Parameter Types" section of the HP-IB Command Reference in the *HP 8711A Operating and Programming Manual*.

Command	Form	Description
DIAGnostic:CCONstants:LOAD	Command	Load correction constants from internal disk drive.
DIAGnostic:CCONstants:STORE:DISK	Command	Store correction constant data to a file named "CC_data" on the internal disk drive.
DIAGnostic:CCONstants:STORE:EEPROM	Command	Store correction constant data from the RAM buffer into flash EPROM.
DIAGnostic:CPU:MEMory[:WORD] <addr num> <data num>	NR1	Write a 16 bit data value to a 68020 address. Query returns an integer with the 16 bit value at the selected address.
DIAGnostic:SNUMBER <string>	STRING	Store a serial number into memory. The string must be 10 characters long. The query form returns the current serial number.
*IDN?	Query STRING	Return a string that uniquely identifies the analyzer, including model number, serial number, and firmware revision.
*OPT?	Query STRING	Return a string identifying the installed options, in the form "1E1, 1C2".
SENSe[1 2]:CORRection[:STATe] <ON 1 OFF 0>	NR1	Turn measurement calibration on/off.
TEST:RESult?	Query CHAR	Query the result of the selected adjustment or self-test. Response will be NULL PASS FAIL.
TEST:SElect <num>	NR1	Select the adjustment or self-test to execute.
TEST:STATe <string>	CHAR	Select the state of the active adjustment or self-test. Choose from RUN CONTInue STOP. Query response will be NULL PAUS DONE.
TEST:VALue <num>	NR1	Set or query a value for an adjustment or self-test.
*TST?	Query NR1	Perform and return the result of a complete self test. An ASCII 0 (zero) indicates no failures found. Any other character indicates a failure.

Theory of Operation

INTRODUCTION

Theory of Operation begins with a general description of the operation of a network analyzer system. This is followed by more detailed operating theory for the HP 8711 in particular, divided into functional groups. The operation of each group is described briefly, to the assembly level only. Detailed component-level circuit theory is not provided here.

Simplified block diagrams illustrate the operation of each functional group. A more detailed overall block diagram is provided at the end of the Troubleshooting section.

SYSTEM THEORY

A network analyzer system consists of a source, signal separation devices, a receiver, and a display. The HP 8711 integrates a synthesized RF source with built-in couplers for signal separation, a combination narrowband and broadband receiver, and a display. Figure 6-1 shows a simplified system block diagram for the HP 8711.

In the HP 8711, the A3 fractional-N/reference and A4 source assemblies provide the synthesized RF source output. The A5 receiver assembly separates the signals into reference, reflected, and transmitted signals. These inputs are processed as either narrowband or broadband signals. Then they are multiplexed into ADCs (analog to digital converters), where they are converted into digital signals. The digital data is processed by the A2 CPU assembly and sent to the A7 display.

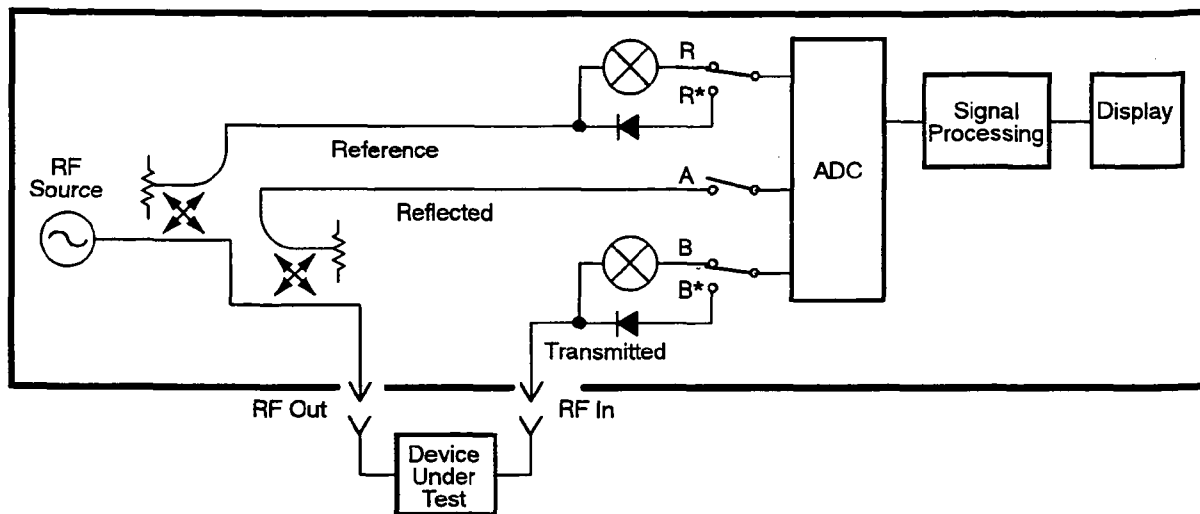

Figure 6-1. Simplified HP 8711 System Block Diagram

ANALYZER FUNCTIONAL GROUPS

Each functional group consists of one or more assemblies that perform one of the basic instrument functions. These groups are the power supply, digital control, source, and receiver.

POWER SUPPLY THEORY

The power supply group consists of the A6 power supply assembly. This switching power supply provides regulated DC voltages to power all assemblies in the analyzer through a connection to the backplane. The backplane serves as a motherboard to provide power, data, and control signal connections to the various assemblies.

A voltage selector switch, accessible at the rear panel, adapts the analyzer to local line voltages of approximately 115V or 230V. Refer to "Installing the HP 8711" in the Operating and Programming manual for line voltage tolerances and other power considerations.

The power supply has a standby state instead of an off state when the AC power is connected. In standby, the A6 assembly provides a +13V supply which is used to power the non-volatile SRAM on the CPU board. (A battery provides power to the non-volatile SRAM when the instrument is disconnected from AC power.) The power supply turns on when the on/standby switch is grounded. In the on state, the power supply provides the following supplies to the instrument: +5V, +15.5V, -15.5V, and +12V.

Two diagnostic LEDs are visible from the rear panel. The green LED is on in normal operation. It is off when the line power is absent or set too low, or if the line fuse has blown. The red LED is on in standby but off during normal operation. It will blink to indicate a power supply shutdown. Refer to the Troubleshooting section for more details.

DIGITAL CONTROL THEORY

This group includes the A1 front panel, A2 CPU, A7 display, and A8 floppy disk drive assemblies.

A1 Front Panel

The A1 front panel assembly allows the user to control the analyzer. It includes a keyboard and RPG knob. A probe power jack that supplies +15V and -12.6V is available for use with RF probes and other accessories. Fuses for these supplies are on the back of the A1 front panel PC board.

A2 CPU

The A2 CPU assembly provides most of the control, interface, and data processing functions in the analyzer. It contains several microprocessors and many different types of memory, as shown on the HP 8711 overall block diagram.

The main CPU is an MC 68020 microprocessor. It is the master controller for the analyzer, including the other dedicated processors on the CPU assembly. When the analyzer is the system controller in an HP-IB system, it also controls peripheral devices through the HP-IB interface.

The TMS 320C25 digital signal processor (DSP) receives the digital data from the A5 receiver board and performs data processing functions such as digital filtering, averaging, and applying error correction. It has some dedicated SRAM for running its firmware, and it also uses some shared DRAM and SRAM which is used to transfer data with the CPU.

The TMS 34010 graphics system processor (GSP) is responsible for converting data from the CPU into video signals to drive the A7 display assembly. It also produces an external video output which is accessible from the rear panel.

A number of processors on the CPU assembly allow the analyzer to interface with the outside world. The front panel processor handles inputs from the front panel keyboard and RPG. The floppy disk controller controls the internal floppy disk drive. The DIN keyboard interface allows a user to connect an external keyboard, which is very useful when writing programs with IBASIC. The Centronics and RS-232 interfaces allow the analyzer to control printers and plotters with a parallel or serial interface. The HP-IB interface allows the HP 8711 to be a system controller or talker/listener on an HP-IB bus. In addition, there are two TTL outputs (user bit and limit test pass/fail bit) that can be accessed by the user. There is also an external trigger input for sweep control.

The firmware for the analyzer is stored in two places. A boot ROM contains low-level firmware that allows the analyzer to run some power-on self-tests and perform functions such as loading firmware from a floppy disk. The main firmware, which includes the analyzer's operating system and additional self-tests, is stored in EPROMs, along with the correction constant data for the instrument. Both the boot ROM and the main EPROMs are flash EPROMs. They can be erased and reprogrammed without removing the CPU assembly from the analyzer. However, erasing the EPROMs for a firmware update also erases the correction constant data, so it is necessary to have a copy of this data on disk for retrieval after the update.

The non-volatile SRAM is used to store instrument state and peripheral state settings. It is also used as a RAM disk by the save/recall functions, which refer to the non-volatile SRAM as "internal memory." This non-volatile SRAM is powered by a +13V supply when the analyzer is in standby, and by a battery when the AC power is disconnected.

The CPU assembly also contains SIMM DRAM. The amount of SIMM DRAM installed in a particular HP 8711 depends on the instrument's option configuration. This SIMM DRAM is used in addition to the main DRAM for normal operation of the CPU. More SIMM DRAM is required for instruments with IBASIC (option 1C2).

A7 Display

The A7 display includes a monochrome 20.8 cm (9 inch) CRT and a matching driver board. Video signals are produced by the A2 CPU assembly and sent to the A7 assembly for display on the CRT. An intensity adjustment is accessible from the front panel.

A8 Floppy Disk Drive

The A8 floppy disk drive is referred to by the analyzer as the internal disk. It accepts double density or high density 3.5 inch floppy disks. It can read from or write to either LIF or DOS format disks. The Save/Recall menus of the HP 8711 can only format disks in DOS format. However, you can use an external controller or IBASIC (option 1C2) to format disks in LIF format if desired.

SOURCE THEORY

The source group consists of the A3 fractional-N/reference assembly and the A4 source assembly.

A3 Fractional-N/Reference

The A3 assembly consists of two boards connected together. The reference board generates the various reference signals used in the analyzer, while the fractional-N (frac-N) board generates a 30 to 60 MHz synthesized signal for use in the A4 source assembly.

The reference board uses either the internal 10 MHz crystal oscillator or an external 10 MHz reference signal to generate three reference signals. The 100 kHz signal is used in the fractional-N VCO phase lock loop. The 10 MHz signal is used by the A4 source assembly. A 5 MHz signal goes to the backplane, where it is routed to the A2 CPU and A5 receiver assemblies for use in signal processing.

The fractional-N board is the synthesizer for the source. The 30 to 60 MHz frac-N VCO output is used for phase-locking the source LO signal, which in turn is used to generate the source RF output.

A4 Source

The source assembly provides two output signals. One signal, which covers the 0.3 to 1300 MHz range, is the main source RF output signal. It goes to the receiver board and through an optional step attenuator before it gets to the RF OUT (REFLECTION) port on the front panel. The other signal serves as the internal receiver LO for downconverting narrowband signals. The two signals are independently phase-locked, and they are separated from one another by the receiver IF (intermediate frequency) of 27.778 kHz.

These two signals are generated from 3 phase-locked VCOs, as shown in Figure 6-2. In normal operation, the RF1 VCO is phase-locked to a 1 MHz reference signal to produce a stationary 2340 MHz signal. (The 1 MHz signal is derived from the 10 MHz output of the A3 frac-N/reference assembly.) Similarly, the RF2 VCO is also phase locked to the 1 MHz reference to produce a stationary signal that is offset from RF1 by the receiver IF of 27.778 kHz. The Source LO VCO supplies the LO drive for the two source mixers. It covers a 2340.3 to 3640 MHz range. It is phase-locked to a fractional-N sweeping synthesizer (A3). As this phase lock loop sweeps, the main Source RF output is generated as the mixing product of the 2340 MHz RF1 signal and the sweeping 2340.3 to 3640 MHz Source LO signal. Similarly, the Receiver LO output is generated by the RF2 signal mixing with the sweeping Source LO, resulting in a signal that is offset from the Source RF output by the receiver IF.

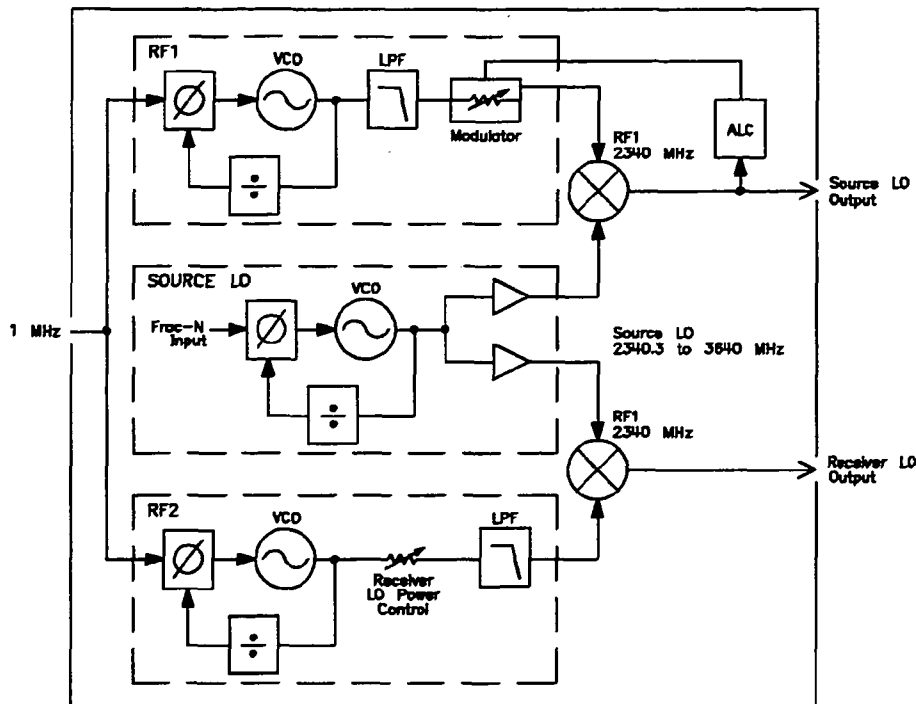

sd82e

Figure 6–2. Simplified Source Block Diagram

Power level control of the source RF output is achieved by using a coupler/detector on the source RF output signal, which controls a modulator on the RF1 signal. Digital correction is applied to the RF2 signal to control the receiver LO power level. Both power levels can be adjusted by running the appropriate service tests. See the “Adjustments” section of this manual for more details.

The source also has a “dither” mode for spur avoidance. When dither is on, the RF1 frequency changes from 2340 MHz to 2304 MHz, and the RF2 frequency changes to $(2304 \text{ MHz} + \text{IF})$ to maintain the 27.778 kHz offset between these two signals. Because of these changes, the mixing products from the two source mixers will be at different frequencies, resulting in spurs that have shifted in frequency when compared to the dither off state. This is used in two ways. The user can select **Dither ON** (under the Source **MENU** key), which causes the analyzer to shift the RF1 and RF2 frequencies to the “dither on” values for all subsequent sweeps, until dither is turned off again. This is useful if the user is only interested in a narrow frequency span, and switching dither on successfully moves a spur out of the span of interest. The user can also select **Spur Avoid ON**. In this case, the analyzer will approach a known spur frequency, switch dither on until it sweeps past the spur, then switch dither off again until it gets to the next spur. This method is more suitable for wider frequency spans, but it slows down the sweep because of the need to turn dither on and off.

RECEIVER THEORY

The A5 receiver assembly is responsible for separating and measuring the RF signals and converting these signals into digital data for further processing by the A2 CPU. Figure 6-3 shows a simplified block diagram of the receiver assembly.

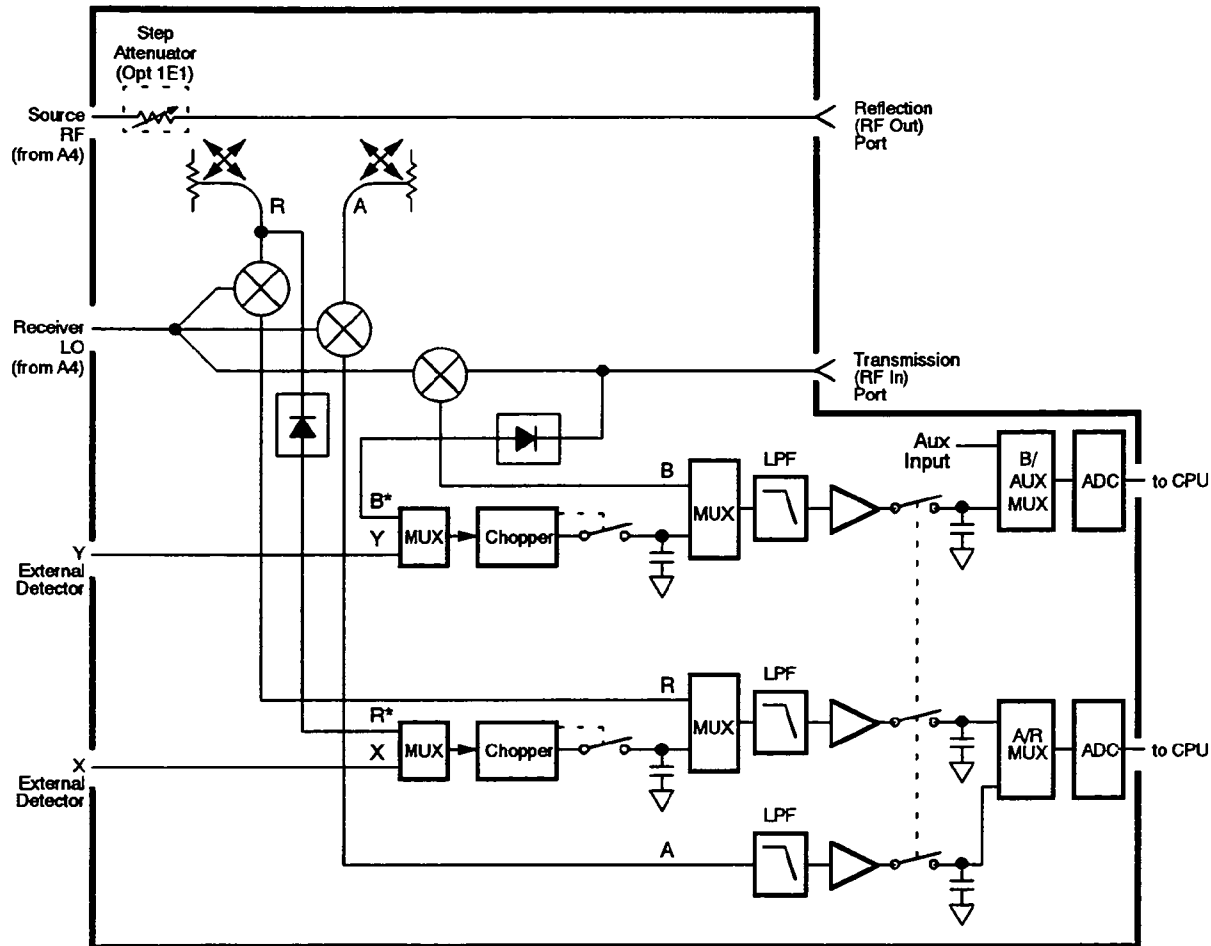

Figure 6-3. Simplified Receiver Block Diagram

The source RF output from the A4 source assembly is input into the receiver. The signal passes through an optional step attenuator, then through two directional couplers. The first coupler measures the source output signal and uses this as a reference (R input). The source output signal travels through the through arm of the second coupler, which is used in reflection measurements to sample the signal reflected from the REFLECTION test port. This reflected signal is referred to as the A input. The source output signal then goes out the REFLECTION port, propagates through the device under test, and enters the receiver again at the TRANSMISSION or RF IN port. The signal from this port is the B input.

The R, A, and B inputs can be processed in one of two ways. For narrowband measurements, the RF input signal is downconverted to a lower IF frequency of 27.778 kHz using mixers. These mixers are driven by the Receiver LO signal from the A4 source assembly. After the signal is downconverted, it is amplified, filtered, and sent to the analog to digital converters (ADCs).

6-6 Theory of Operation

For broadband measurements, the RF input is converted to a DC signal with a diode detector. This DC signal is chopped at a 27.778 kHz rate and then sampled at a rate of 55.5 kHz. This signal is then amplified, filtered, and sent to the ADCs. The HP 8711 has two internal diode detectors, B* and R*. The A input does not have a broadband detector.

The analyzer can also use one or two external broadband detectors. These detectors convert the measured RF signal into DC signals, which are referred to as the X and Y inputs. The DC inputs are multiplexed into the same choppers used for the B* and R* detectors: the B* and Y inputs share a chopper, and so do R* and X. The signal then follows the same path as the one used for the internal broadband detection.

There is also a rear panel connector for an auxiliary input. This input displays DC or low frequency AC signals from -10 to +10 volts.

The analyzer uses adjustment tests to generate correction constant data for all of the internal narrowband and broadband inputs. For the external detectors, the correction constants are stored in an EEPROM in the detector. This data can be read by the receiver to correct data for the X and Y inputs.

There are two 16-bit ADCs on the receiver assembly. The two ADCs are multiplexed between the various narrowband/broadband, internal/external signals. The ADCs require a 2.5 MHz clock signal from the CPU board. They convert the 27.778 kHz signal into digital data, which is then sent to the digital signal processor (DSP) on the A2 CPU board.

Replaceable Parts

INTRODUCTION

Use this chapter to order replaceable parts and remove and reinstall those parts (installation procedures are the reverse of the removal procedures). For component-level repair refer to the schematic package (see the documentation parts list). In keeping with the assembly-level repair strategy of the instrument, this chapter documents the following:

- major assemblies
- cabinet parts
- miscellaneous parts
- RF shields
- documentation
- post repair procedures

Warning **Parts of this instrument have sharp edges. Work carefully to avoid injury.**



TOOLS REQUIRED

Torxdriver sizes 10 and 15
5/8 in. wrench (for BNC nuts)
5/16 in. wrench
5/16 in. nut driver (for CRT nuts)

HOW TO ORDER PARTS

Refer to the following parts lists to identify the part and its part number. All of the part numbers listed are HP part numbers but commercially available parts are noted with an asterisk (*). To order the part, use the part number listed, state the quantity desired, and address the order to the nearest Hewlett-Packard office. To save money or time, read the following paragraphs.

To order parts not listed, include the instrument model number, complete instrument serial number, description and function of the part, and quantity desired.

Save Money by Ordering R-E (Rebuilt-Exchange) Assemblies

If you need to replace an assembly and would like to save money, consider a R-E (rebuilt-exchange) assembly. These factory-repaired, tested assemblies are available on a trade-in basis. They meet all factory specifications required of a new assembly. They are designated (R-E) in the following parts lists.

Save Time by Calling (800) 227-8164

To order parts as fast as possible, call the above number Monday through Friday, 6am to 5pm PST. You will contact HP parts specialists with direct on-line access to the parts listed in this manual. Four-day delivery is standard; one-day (hotline) delivery is available for an additional charge. Outside of the United States, contact your nearest HP office.

MAJOR ASSEMBLIES

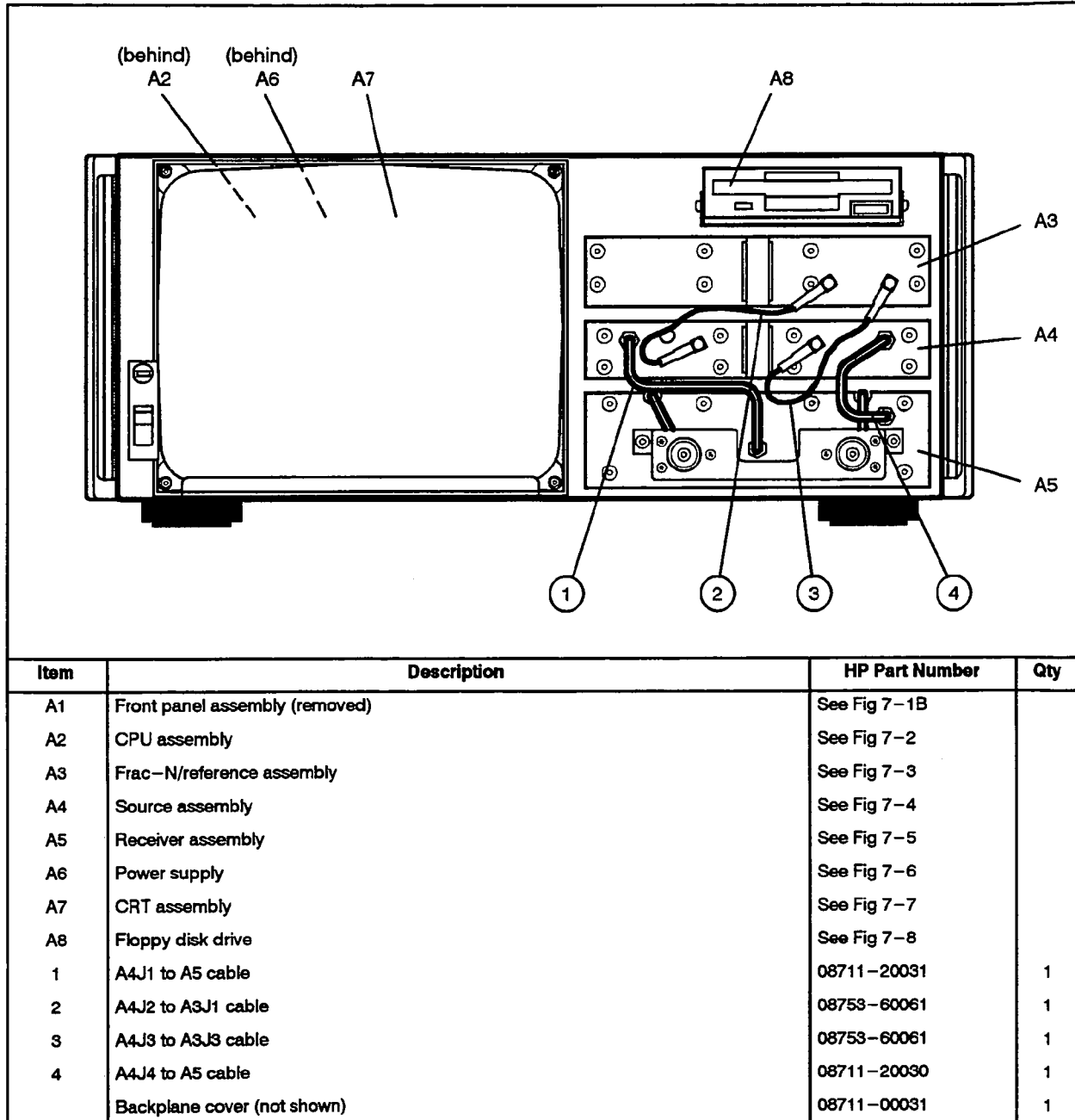

Figure 7-1A. Major Assemblies and Cables

A1 FRONT PANEL ASSEMBLY

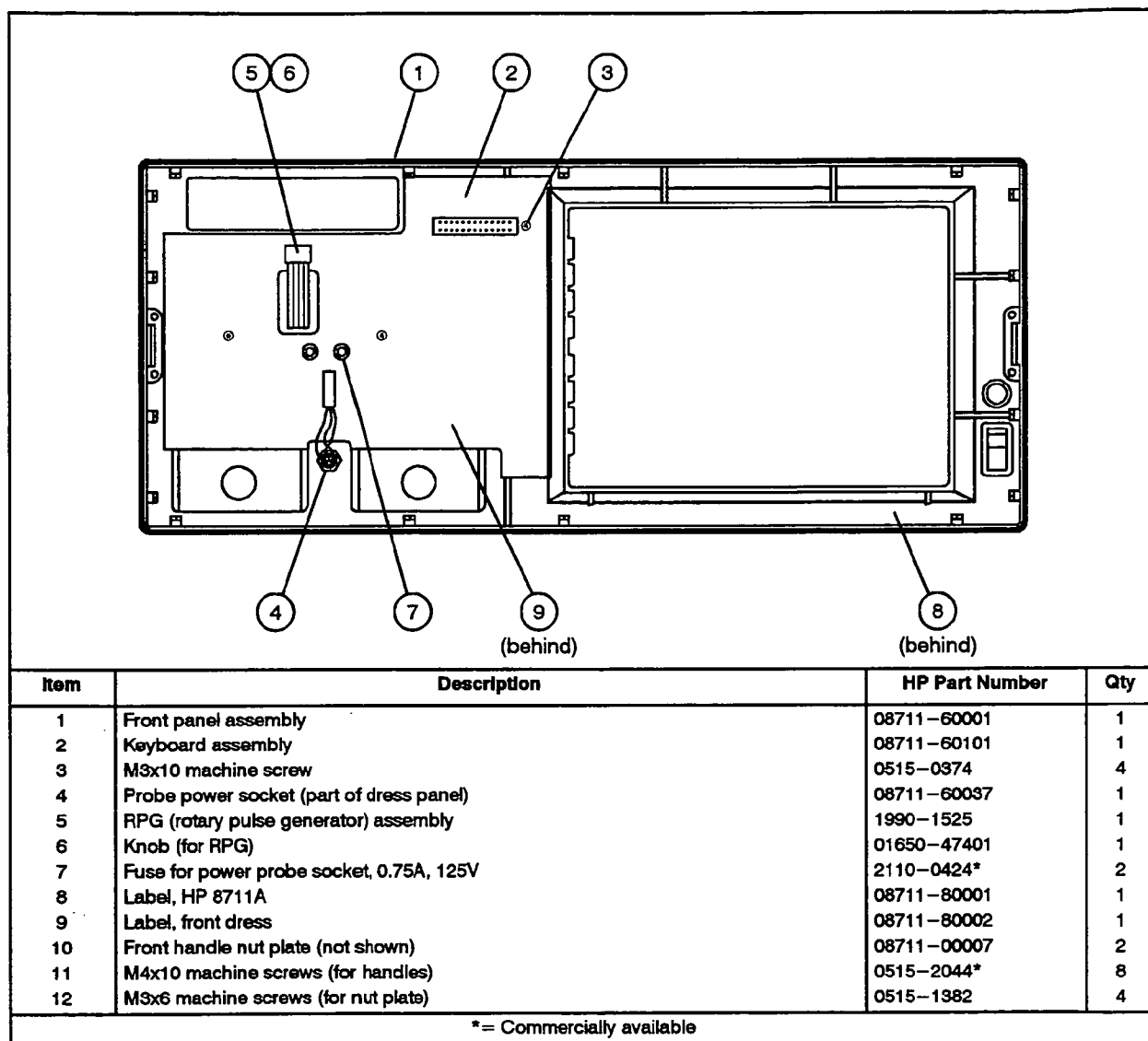

Figure 7-1B. Front Panel Assembly Replaceable Parts

How to Remove the Front Panel Assembly

Disconnect the power cord.

Remove the front handles (trim strip first). Pull the center top of the front panel up slightly and pull the center bottom down slightly to release the two catches. Then pull the front panel away from the cabinet several inches. Disconnect the ribbon cable from the circuit board. If you need to remove one of the assemblies inside the analyzer, remove the metal front handle nut plates (2).

To remove the RPG knob, pull it off its splined shaft. To remove the RPG, disconnect the five-wire cable from J2. Remove the knob, hex nut, and washer.

Note

The probe power fuses are in sockets.



A2 CPU ASSEMBLY

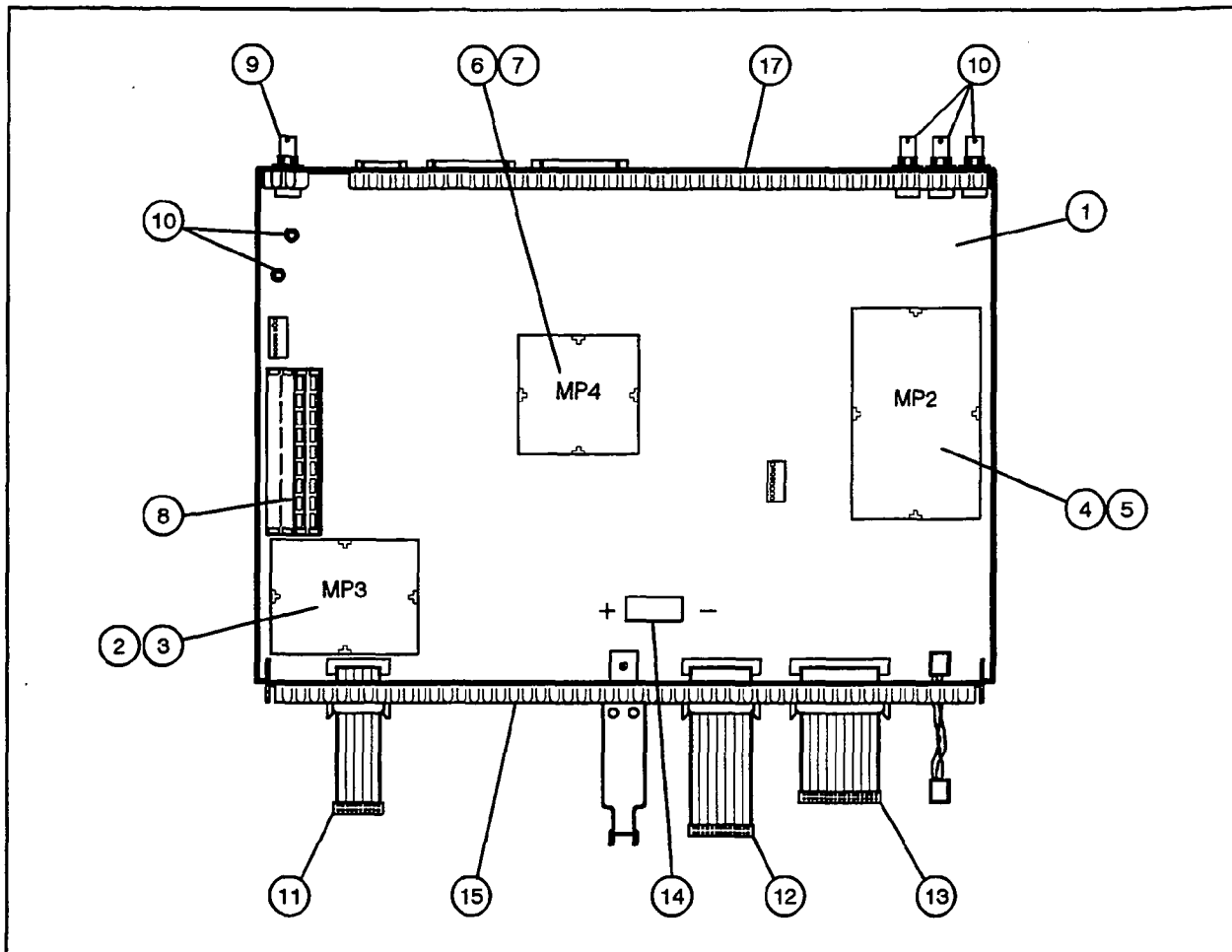

Item	Description	HP Part Number	Qty
1	A2 CPU assembly (new) A2 CPU assembly (R-E)	08711-60002 08711-69002	1
2	GSP shield (MP3 bottom strip)	08711-20054	1
3	GSP shield (MP3 cover)	08711-20055	1
4	DSP shield (MP2 bottom strip)	08711-20056	1
5	DSP shield (MP2 cover)	08711-20057	1
6	CPU shield (MP4 bottom strip)	08711-20058	1
7	CPU shield (MP4 cover)	08711-20059	1
8	DRAM, standard instrument (256 Kbyte) DRAM, option 1C2 instrument (1 Mbyte)	1818-4268 1818-5337	2 2
9	BNC jacks	1250-1842*	4
10	Fuse, DIN interface, 3A 125V	2110-0332*	2
11	Display ribbon cable assy	8120-5526	1
12	Front panel ribbon cable assy	8120-5527	1
13	Floppy disk drive ribbon cable assy	8120-5528	1
14	Battery, 3.0V	1420-0338	1
15	CPU front shield assembly	08711-60032	1
16	CPU rear shield assembly	08711-60031	1

* = Commercially available

Figure 7-2. A2 CPU Assembly Replaceable Parts

7-4 Replaceable Parts

How to Remove the CPU Assembly

Disconnect the power cord.

Disconnect any cables from these connectors in the top row of the rear panel: user TTL output, limit test TTL output, ext trig in/out, HP-IB, parallel port, RS-232, DIN keyboard, and video out.

Remove the front panel (details are in Figure 7-1B on page 7-3).

Remove the display assembly (details follow Figure 7-7, on page 7-12).

Remove the floppy disk drive (details follow Figure 7-8, on page 7-14).

Withdraw the CPU assembly from its cavity.

To reinstall the CPU assembly, first make sure the 3-wire disk drive cable assembly is connected to it.

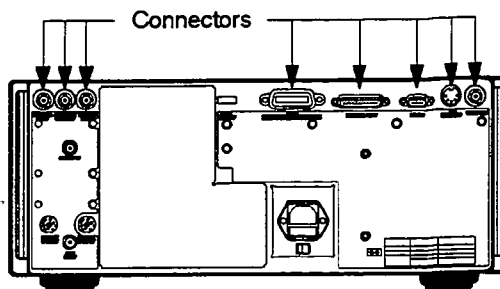

A3 FRAC-N/REFERENCE ASSEMBLY

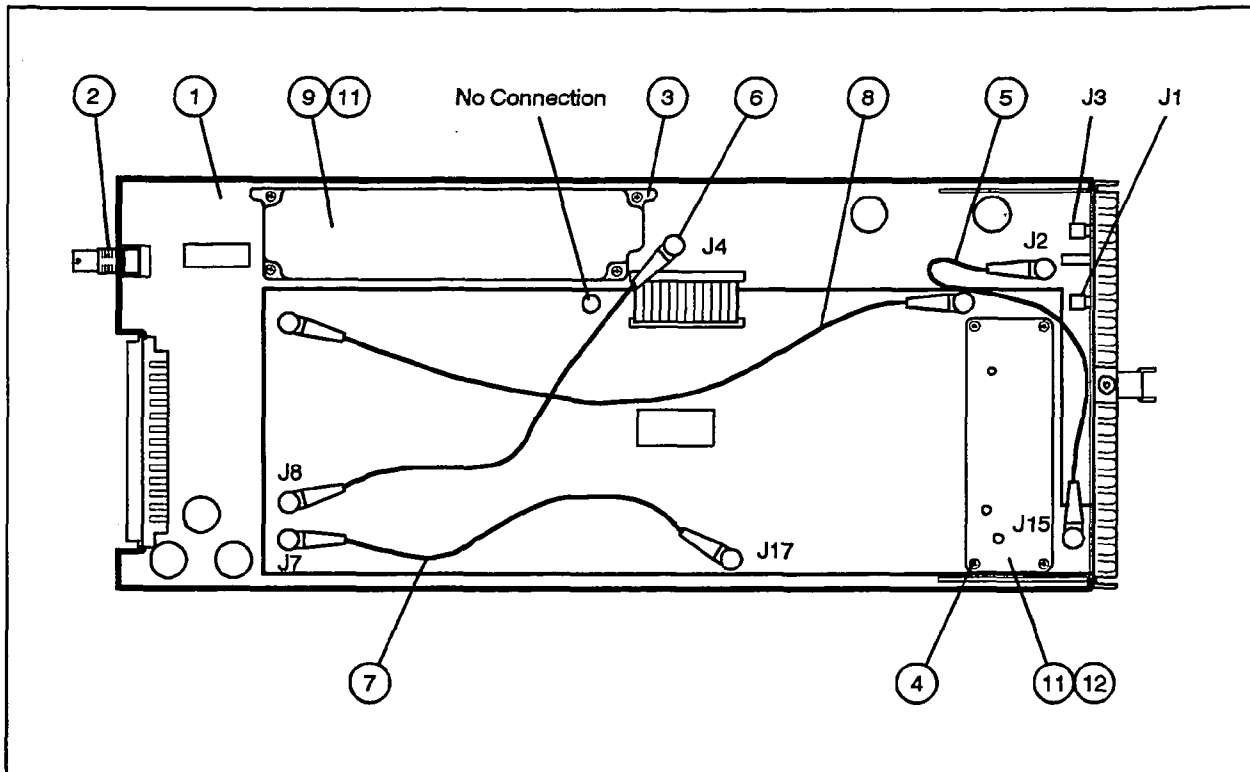

Item	Description	HP Part Number	Qty
1	A3 Frac-N/reference ckt bd assy (new)	08711-60003	1
	A3 Frac-N/reference ckt bd assy (R-E)	08711-69003	-
2	J6 external reference input jack, BNC	1250-1842*	1
	Hex nut for BNC jack (not shown)	2950-0054	1
	Washer for BNC jack (not shown)	2190-0068	1
3	10 mm machine screw	0515-0374*	4
4	35 mm machine screw	0515-1038*	4
5	J2 to J15 8.5 in. cable	8120-2587	1
6	J4 to J8 8.5 in. cable	8120-2587	1
7	J7 to J17 8.5 in. cable	8120-2587	1
8	J18 to J18 SH 12 in. cable	8120-2586	1
9	Shield, frac-N (top)	08711-20020	1
10	Shield, frac-N (bottom)	08711-20021	1
11	Shield, frac-N/VCO (top)	03325-40602	1
12	Shield, frac-N/VCO (spacer plate)	03325-40601	1
J1	Frac-N output (SMB)	1250-1512	
J3	10 MHz reference output (SMB)	1250-1512	

* = Commercially available

Note



Item 1 consists of two circuit boards. Do not take them apart. They must be ordered together with the above part number.

Figure 7-3. A3 Frac-N/Reference Assembly Replaceable Parts

How to Remove the Frac-N/Reference Assembly

Disconnect the power cord.

Remove the front panel (details are in Figure 7-1B on page 7-3).

Disconnect, if present, the cable from the external reference input on the rear panel.

Remove the nut and washer from the BNC connector.

Disconnect the two cables from the front of the assembly.

Withdraw the assembly from its cavity.

Ext Ref Input

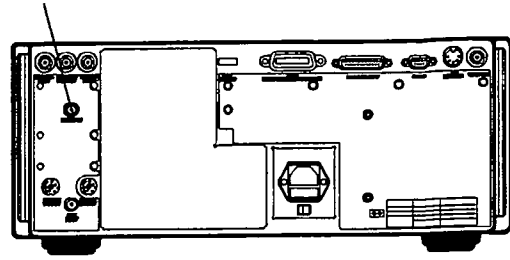

A4 SOURCE ASSEMBLY

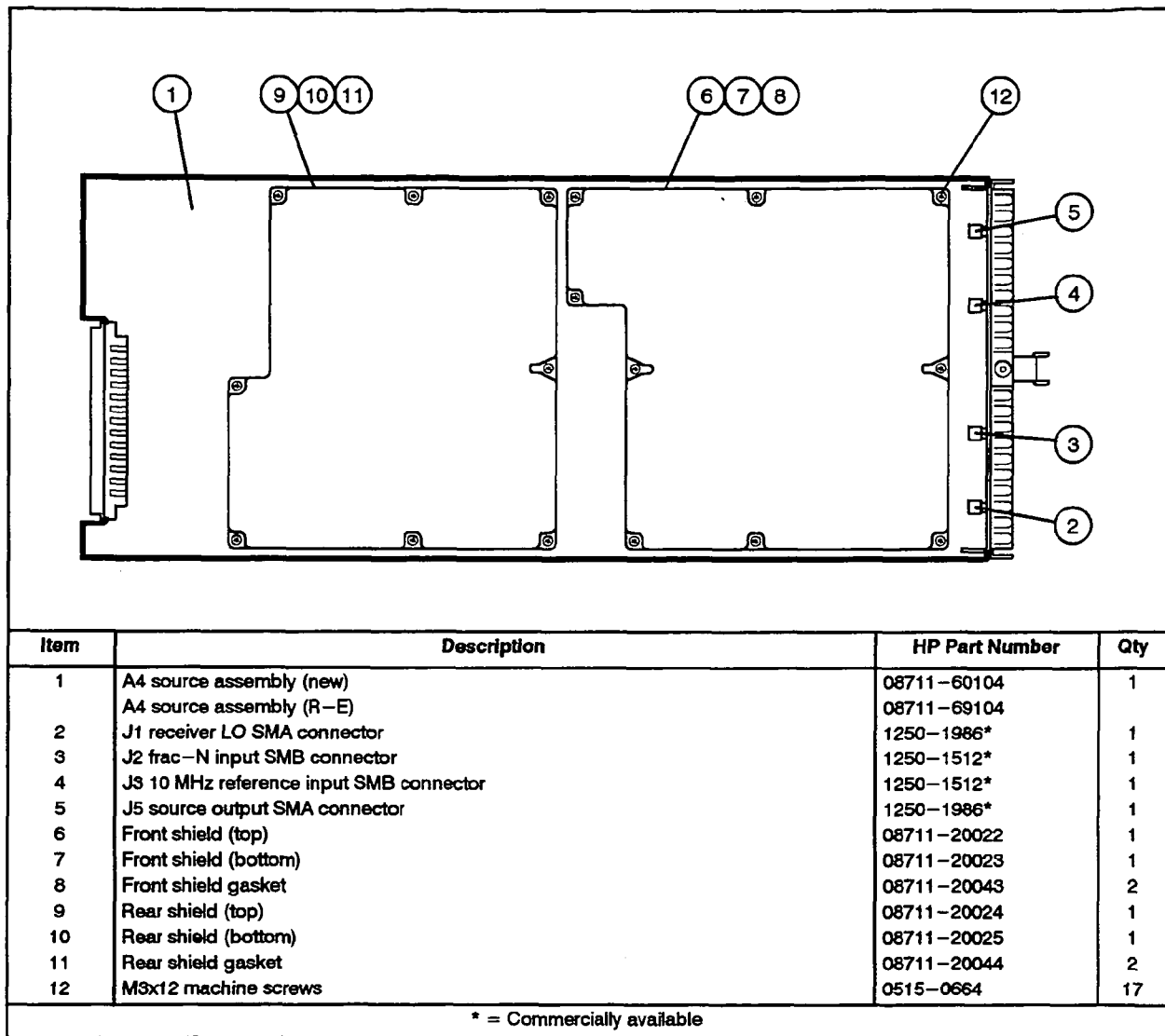

Figure 7-4. Source Assembly Replaceable Parts

How to Remove the Source Assembly

Disconnect the power cord.

Remove backplane cover by pressing upwards on tab at top (see disassembly label).

Remove rear panel screw.

Remove the front panel (details are in Figure 7-1B on page 7-3).

Disconnect the four cables from the front of the source assembly.

Withdraw the source assembly from its cavity.

7-8 Replaceable Parts

A5 RECEIVER ASSEMBLY

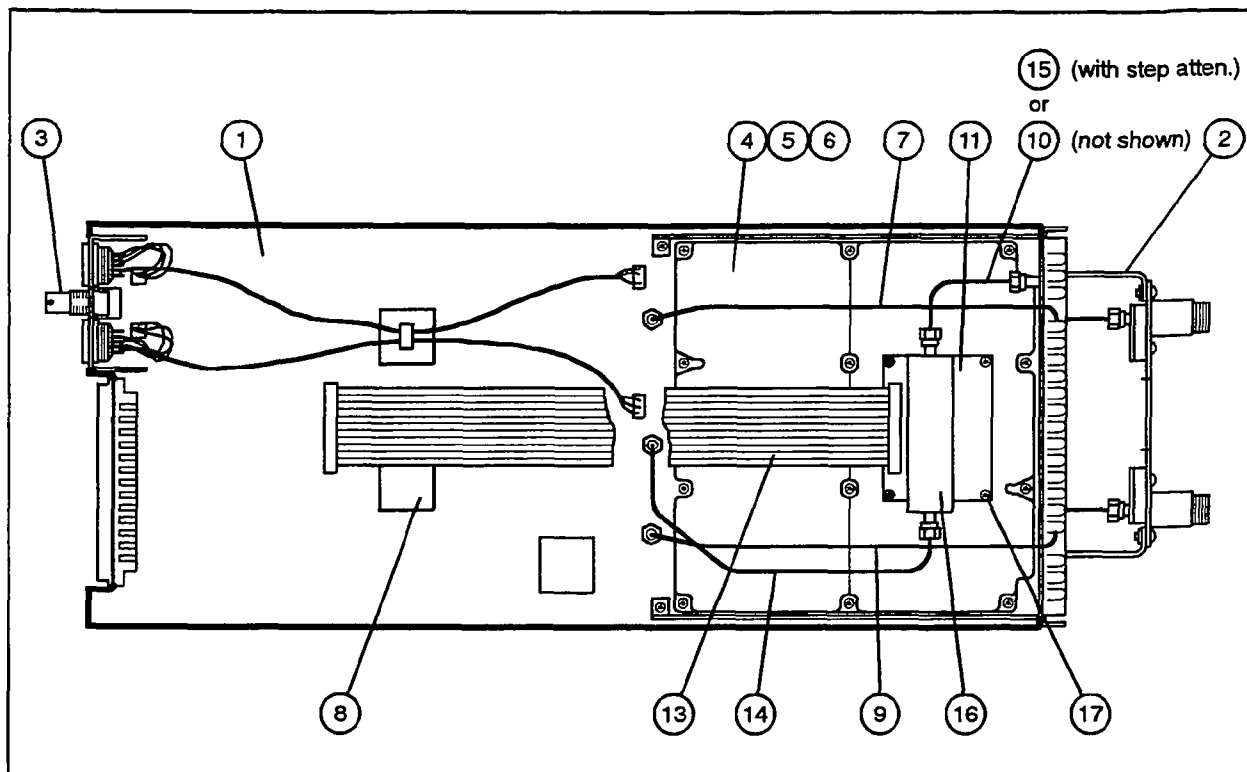

Item	Description	HP Part Number	Qty
1**	A5 50 ohm receiver assembly (new) A5 50 ohm receiver assembly (R-E) A5 75 ohm receiver assembly (new) A5 75 ohm receiver assembly (R-E)	08711-60105 08711-69105 08711-60070 08711-69070	1
2	Test port assy (connectors and bracket)	08711-60038	1
3	Aux input BNC connector Hex nut for BNC connector Washer for BNC connector	1250-1842* 2950-0054 2190-0068	1
4	Square shield (top)	08711-20027	1
5	Square shield (bottom)	08711-20026	1
6	Square shield gasket	08711-20040	2
7	RF IN connector to J4 cable assy	08711-20033	1
8	Not used		
9	J2 to RF OUT cable	08711-20032	1
	PARTS SPECIFIC TO INSTRUMENTS WITHOUT STEP ATTENUATOR		
10	Source RF to J3 cable assy (not shown)	08711-20034	1
	PARTS SPECIFIC TO INSTRUMENTS WITH OPTIONAL STEP ATTENUATOR		
11	Step attenuator assy (inc. attn & PCB)	08711-60051	
12	Step attn PCB (part of item 11)	08711-60053	
13	Step attenuator ribbon cable assy	8120-5524	
14	J3 to step attenuator cable assy	08711-20036	
15	Step attn to front panel cable assy	08711-20035	
16	Screws to fasten step attenuator	*	
17	M3x8 screws (for step attn PCB)	0515-0372*	4
* = Commercially available			
** A5 receiver assy includes items 9 and 7. Reuse all other associated parts.			

Figure 7-5. A5 Receiver Assembly Replaceable Parts

How to Remove the Receiver Assembly

Disconnect the power cord.

Disconnect any cables from the EXT DET X-INPUT, EXT DET Y-INPUT, and AUX INPUT rear panel BNC connectors.

Remove nuts and washers from BNC connectors.

Remove screw on bottom of instrument.

Remove the front panel (details are in Figure 7-1B on page 7-3).

Remove cables between A4 source and A5 receiver board assemblies.

Withdraw the assembly from its cavity.

A6 POWER SUPPLY

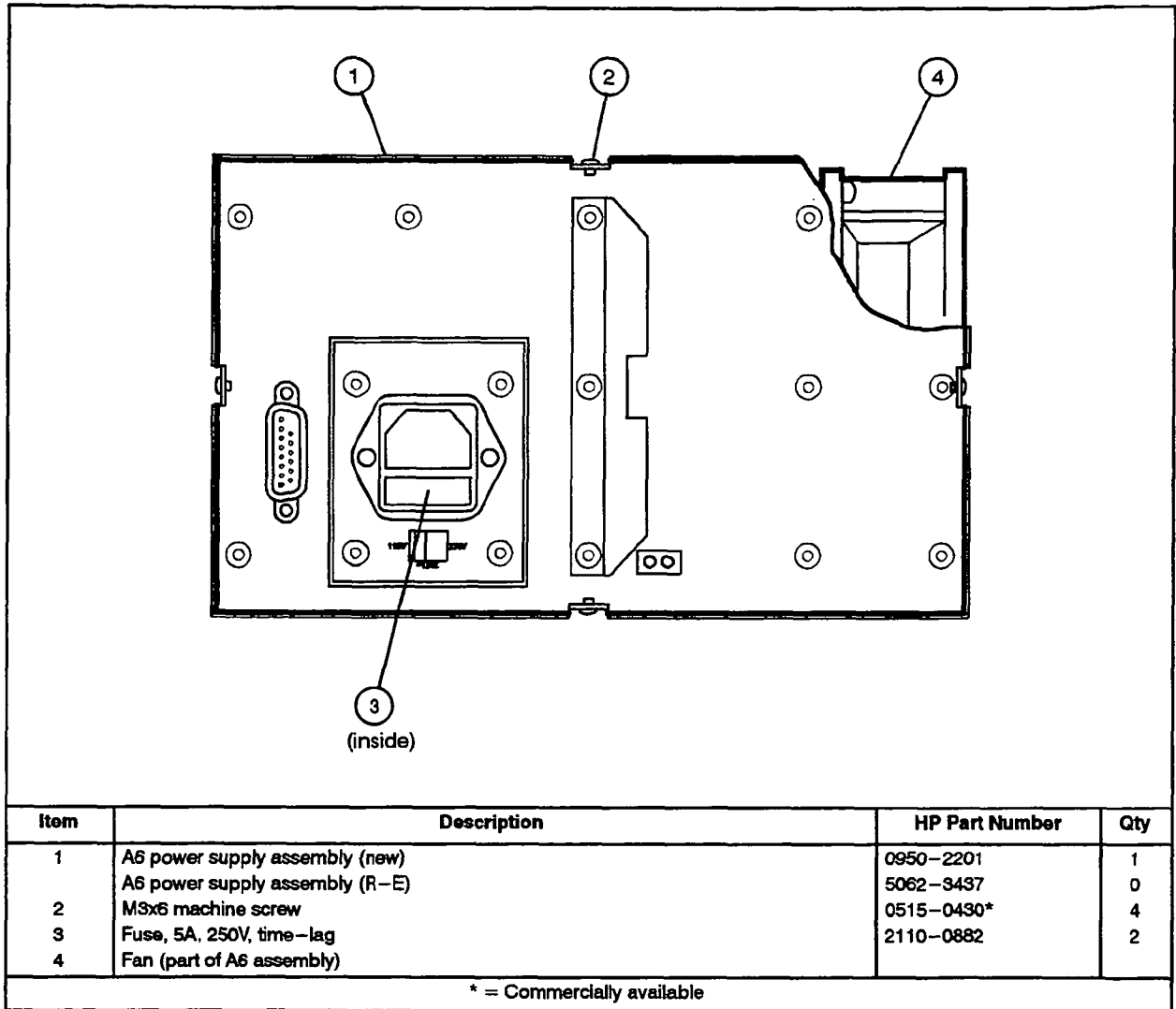

Figure 7-6. A6 Power Supply Assembly Replaceable Parts

How to Remove the Power Supply Assembly

Disconnect the power cord.

Remove the front panel (details are in Figure 7-1B on page 7-3).

Remove the display enclosure (details follow Figure 7-7, on page 7-12).

Remove the four screws along the rear edge of the display enclosure.

Lift open the CRT access panel and disconnect the two-wire cable from the power supply.

Withdraw the power supply from the housing.

A7 DISPLAY ASSEMBLY

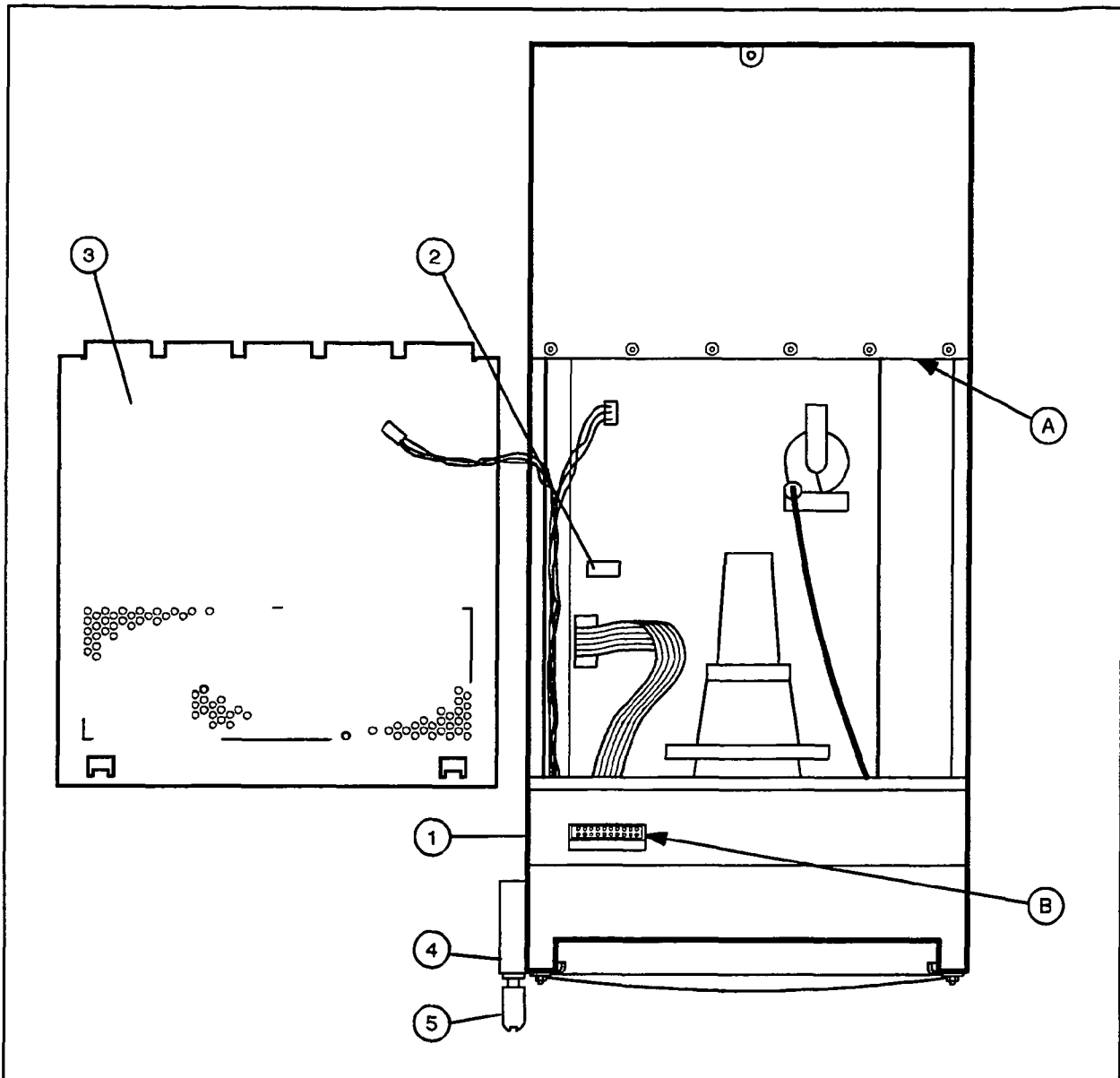

Item	Description	HP Part Number	Qty
1	Display assembly (CRT, PC bd assembly, display enclosure) (new)	08711-60007	1
	CRT assembly (CRT and PC bd assy)	2090-0211	
	Display enclosure	08711-60012	
2	Fuse (for replacement, part of item 1)	not available	
3	Display enclosure cover (for replacement, part of item 1)	08711-00008	1
4	Line switch/intensity adjustment	08711-60009	1
5	Intensity knob	08711-40004	1

* = Commercially available

Figure 7-7. Display Assembly Replaceable Parts

How to Remove the Display Assembly

Disconnect the power cord.

Remove the two screws from the rear panel.

Remove the two screws from the bottom cover of the instrument.

Remove the front panel (details are in Figure 7-1B on page 7-3).

Withdraw the enclosure 2 or 3 inches from its cavity.

Disconnect the ribbon cable from the jack behind the top of the CRT (item B, Figure 7-7 on page 7-12).

Withdraw the enclosure completely from its cavity.

NOTE: The rear panel end of the enclosure is heavy. Don't let it slip as it comes out.

Note



The CRT itself and its PC board assembly are a matched pair and must be replaced together.

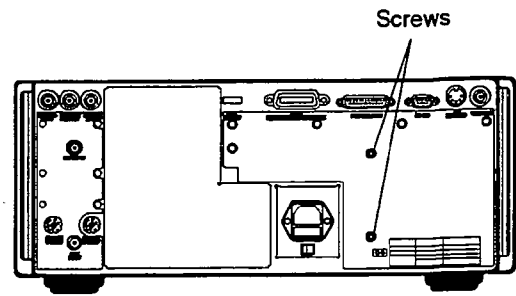

To replace the power switch or brightness control, remove the display enclosure from the instrument. Hold the switch cover (item 4, Figure 7-7) by the top and bottom edges, push back slightly to release the tabs, and rotate outward and toward the back to remove. Both switches and cables must be replaced as a unit.

A8 FLOPPY DISK DRIVE

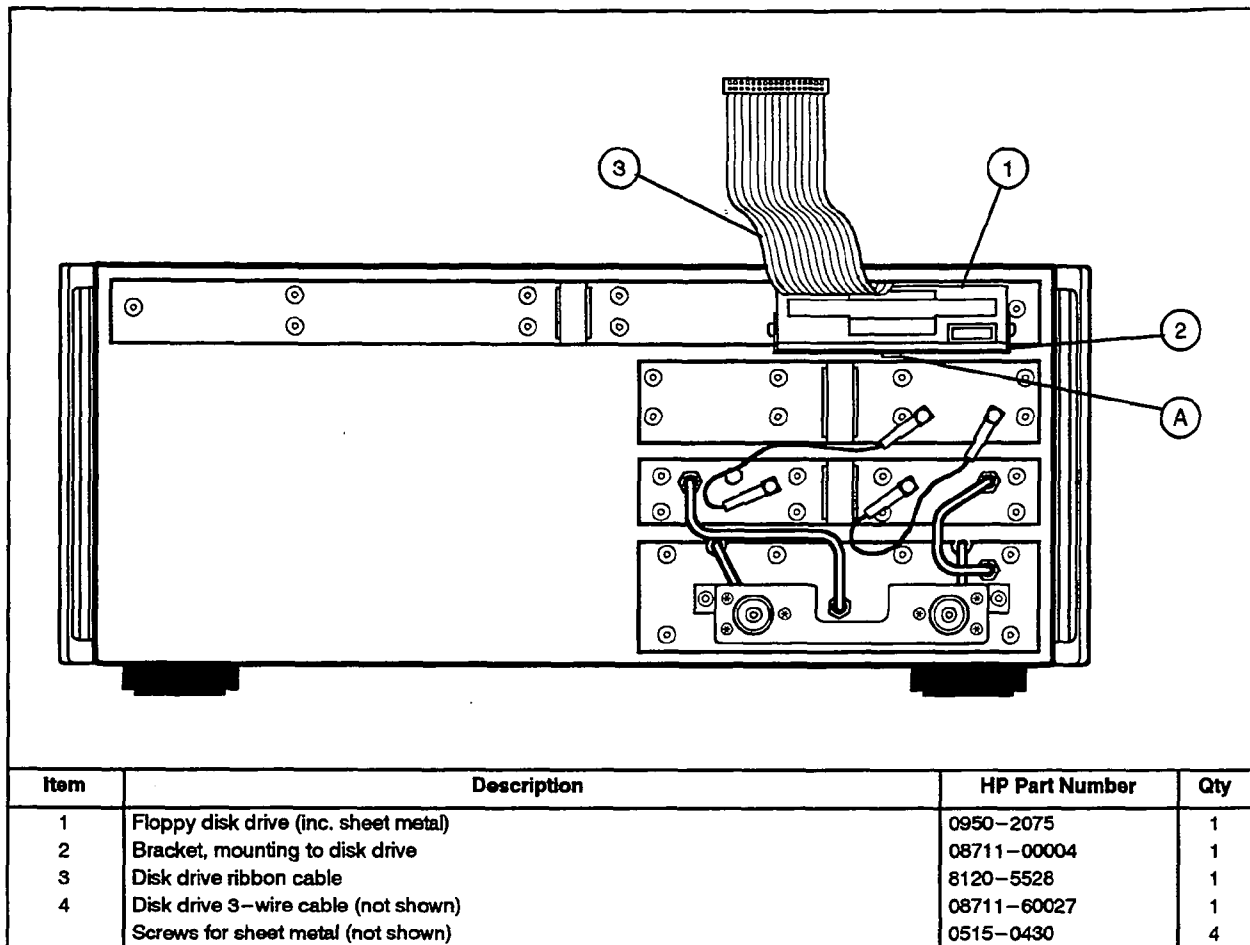

Figure 7-8. Floppy Disk Drive Replaceable Parts

How to Remove the Disk Drive Assembly

Disconnect the power cord.

Remove the front panel (details follow Figure 7-1B on page 7-3).

Press up on the middle tab (item A, Figure 7-8 on page 7-14) on the underside of the drive to release the drive.

Withdraw the drive from the cavity just enough to disconnect the 3-wire cable and the ribbon cable at the drive.

To replace the disk drive assembly if the 3-wire cable disconnects from the A1 assembly within the cabinet rather than the disk drive, follow these tips:

- Stand the analyzer up on its rear panel (after disconnecting cables as required).
- Straighten the 3-wire cable.
- Maneuver the cable jack into position above the socket on the A1 assembly. Note the orientation of the jack.
- Use a long flat-blade screwdriver to press the jack into its socket.

As an alternative, remove the display enclosure and the A1 CPU assembly.

7-14 Replaceable Parts

CABINET AND MISCELLANEOUS PARTS

Description	HP Part Number
CABINET PARTS	
Power cord (varies by country, consult your CE)	
Front handle (one, two per instrument)	5062-3800
Front handle trim	5001-0540
Screws for front handles	0515-0982
Foot (requires foot pad, below)	08711-40005
Foot pad, rubber (for use with foot, above)	0403-0424
RFI spring strip, 16 in. (cut as required)	8160-0775
Rear panel connectors (see appropriate board)	
Backplane cover	08711-00031
Disassembly label (on bottom of instrument)	08711-80006
Rear panel label	08711-80003
Cabinet color: French Gray	
Fuse, power supply	See Fig 7-6
SOFTWARE:	
Performance test program	08711-10009
HP-IB example programs disks	08711-60016
Example programs disk (LIF format, part of 08711-60016)	08711-10003
Example programs disk (DOS format, part of 08711-60016)	08711-10005
IBASIC Example programs disk	08711-10006
ACCESSORIES	
50 ohm 3.5 mm calibration kit	HP 85033C opt 001
50 ohm type-N calibration kit	HP 85032B/E
50 ohm 3.5 mm accessory kit	HP 11878A
50 ohm type-N accessory kit	HP 11853A
50 ohm BNC accessory kit	HP 11854A
50 ohm type-N to TNC adapter kit	HP 86212A
50 to 75 ohm minimum loss pad	HP 11852B
75 ohm type-N calibration kit	HP 85036B/E
75 ohm type-N accessory kit	HP 11855A
75 ohm type-N to 75 ohm BNC assy kit	HP 11856A
75 ohm type-N to type-F adapter kit	HP 86211A
24 inch BNC test port cable (50 ohm)	HP 8120-1839
50 ohm type-N test port cable	HP 8120-4781
75 ohm type-N test port cable	HP 8120-2408
1.0 meter HP-IB cable	HP 10833A
2.0 meter HP-IB cable	HP 10833B
4.0 meter HP-IB cable	HP 10833C
0.5 meter HP-IB cable	HP 10833D
High frequency probe	HP 85024A
50 ohm RF scalar detector	HP 86200A

Description	HP Part Number
50 ohm RF bridge	HP 86205A
75 ohm RF scalar detector	HP 86201A
75 ohm RF bridge	HP 86207A
UPGRADE KITS	
Attenuator (opt 1E1) upgrade kit	08711-60060
IBASIC (opt 1C2) upgrade kit	08711-60061
Firmware kit	08711-60063 or HP 86226A
SERVICE TOOLS	
Service tool kit	08711-60010
DOCUMENTATION	
HP 8711 operating & service manual set	08711-90106
HP 8711 operating manual	08711-90107
HP 8711 service manual	08711-90108
HP 8711 schematic package	08711-90004
HP 8711 IBASIC manual set	08711-90112

POST REPAIR PROCEDURES

Post Repair Procedures		
Replaced Assembly	Adjustments	Verification Tests
A1 Front Panel	None	Operator's Check
A2 CPU	Set Serial Number Re-load correction constant file from disk OR Set Serial Number LO Power Correction Aux Input Correction Switched Gain Correction External Detector Correction Source Power Correction B Amplitude Correction Transmission (B/R) Correction Reflection (One Port) Correction R* Amplitude Correction R* Frequency Response Correction B* Amplitude Correction	Power Range and Flatness Broadband Frequency Response Dynamic Accuracy Absolute Power Accuracy System Directivity and Port Match
A3 Frac-N/Reference	Frequency Accuracy Adjustment Fractional-N VCO Adjustment Fractional-N Spur Adjustment	Frequency Range and Accuracy Test Spurious Signals Test
A4 Source	LO Power Correction Source Power Correction	Power Range and Flatness Spurious Signals Test
A5 Receiver	LO Power Correction Switched Gain Correction Aux Input Correction External Detector Correction Source Power Correction B Amplitude Correction Transmission (B/R) Correction Reflection (One Port) Correction R* Amplitude Correction R* Frequency Response Correction B* Amplitude Correction	Dynamic Range Test Power Range and Flatness Broadband Frequency Response Dynamic Accuracy Test Spurious Signals Test Absolute Power Accuracy Test System Directivity and Port Match
A6 Power Supply	None	Power-on self tests
A7 Display	Check display intensity	Power-on self tests
A8 Floppy Disk Drive	None	Functional test: write and read a file to disk

HP 8711A RF Network Analyzer

INDEX

A

Absolute Power Accuracy Automated Performance Test, 2-41
Accessories ID, 7-15
Adjustment Description, 3-1
Adjustments, 3-1
 B Amplitude Correction, 3-21
 B* Amplitude Correction, 3-26
 External Detector Correction, 3-16
 Firmware, 3-1
 Fractional-N Spur, 3-5
 Fractional-N VCO, 3-3
 Frequency Accuracy, 3-9
 LO Power Correction, 3-13
 R* Amplitude Correction, 3-24
 R* Frequency Response Correction Adjustment, 3-25
 Reflection Correction, 3-23
 Set Serial Number, 3-11
 Source Power Correction, 3-18
 Switched Gain Correction, 3-14
 Transmission Correction, 3-22
Adjustments, Summary of, 5-4
ALC DAC, 5-7
Amplitude (B) Correction Adjustment, 3-21
Analog Bus Menu, 5-9
Analog Bus Nodes, 5-9
Analyzer Calibration Cycle, 2-3
Automated Performance Tests, 2-22
 When to Perform, 2-2
Automated System Addresses, 2-24
Automated System Connections, 2-23
Automated System Setup, 2-22
Automated Test Software Loading and Running, 2-27
AUX in Correction Adjustment, 3-17

B

B Amplitude Correction Adjustment, 3-21
B* Amplitude Correction Adjustment, 3-26
B* Chan DAC, 5-7
Backing Up the Software Program, 2-25
BASIC Operating System, 2-23
Binaries and Drivers, 2-23
Broadband Frequency Response Performance Test, 2-20

C

Cabinet Parts ID, 7-15
Calculation Worksheet
 for 50 ohm Option 1E1 Instruments, 2-51

 for 50 ohm Standard Instruments, 2-49
 for 75 ohm Option 1E1 Instruments, 2-55
 for 75 ohm Standard Instruments, 2-53
Calibration Cycle, 2-3
Clearing Nonvolatile Memory (SRAM), 5-11
Compatible Disk Drives, 2-22
Compatible Printers, 2-23
Compression, 2-13
Controllers, 2-22
Copy from Flexible Disk to Flexible Disk, 2-26
Copy to a Hard Disk, 2-26
Copy to a High Density Flexible Disk, 2-26
Correction Constants, How to Update, 5-8
CPU Assembly, 7-4
 How to Remove, 7-5
 Parts ID, 7-4
 Theory of Operation, 6-3
CRT Cleaning, 1-2

D

Data Disk, 2-27
Detect Cal ON off, 5-8
Detector (External) Correction Adjustment, 3-16
Device Configuration, 2-28
Digital Control Theory, 6-3
Directivity, 5-8
Disk
 Data, 2-27
 Program, 2-27
Disk Drive, 2-22
Disk Drives, Compatible, 2-22
Disk Initializing, 2-25
Display Assembly, 7-12
 How to Remove, 7-13
 Parts ID, 7-12
 Theory of Operation, 6-4
Documentation, Part Numbers, 7-16
Drivers, 2-24
Dynamic Accuracy, 2-4
Dynamic Accuracy Automated Performance Test, 2-34
Dynamic Range, 2-4
Dynamic Range Performance Test, 2-13

E

Edit Mass Storage, 2-27
Edit the Device Configuration, 2-28
Exchange Parts, 7-1
Execute Test, 5-2

External Detector Correction Adjustment, 3-16

F

Firmware Adjustments, 3-1
Firmware Revision, to See on Screen, 5-6
Flatness, 2-17
Floppy Disk Drive, 7-14
 How to Remove, 7-14
 Parts ID, 7-14
 Theory of Operation, 6-4
Frac-N/Reference Assembly, 7-6
 How to Remove, 7-7
 Parts ID, 7-6
 Theory of Operation, 6-4
Fractional-N Spur Adjustment, 3-5
Fractional-N VCO Adjustment, 3-3
Frequency, 2-5
Frequency Accuracy Adjustment, 3-9
Frequency Range and Accuracy Performance Test, 2-10
Front Panel Assembly, 7-3
 How to Remove, 7-3
 Parts ID, 7-3
Front Panel Removal, 3-3
Front Panel, Theory of Operation, 6-3
Fuse, Probe Power, Rating, 7-3
Fuse, Rating, 7-11

G

Gain (Switched) Correction Adjustment, 3-14

H

Hardware Requirements, 2-22
Hotline for Parts, 7-2
How to Clear SRAM, 5-11
How to Order Parts, 7-1
HP-IB Command Reference, 5-14

I

IF Gain Auto, 5-7
IF Gain AUTO man, 5-7
IF Gain Hi on OFF, 5-7
IF Gain Lo ON off, 5-7
Initialize a Disk, 2-25
Installed Options, to See on Screen, 5-6
Instrument Info, 5-6
Internal Diagnostics, 5-1

L

Language Extensions, 2-24
Line Fuse, 7-11
LO Power Adjust, 5-7

LO Power Correction Adjustment, 3-13
Load CC from Disk, 5-8
Load the Operating System and Binaries, 2-24
Loading and Running the Test Software, 2-27

M

Major Assemblies, 7-2
Manual Performance Tests, When to Perform, 2-2
Mass Storage, 2-27
Maximum Input Level, 2-4
Meas Cal ON off, 5-7
Meas Cal Options Menu, 5-7
Miscellaneous Parts, 7-15
More Svc Utilities, 5-7
More Svc Utilities Menu, 5-7

N

Narrowband Response, 5-8
Noise Floor, 2-14

O

Operating Characteristics, 2-5
Operating System and Binaries, 2-24
Operator's Check, 2-7
When to Perform, 2-2
Organization of Service Manual, 1-1

P

Parts Hotline, 7-2
Parts ID, 7-8
Parts, How to Order, 7-1
Parts, How to Remove, 7-1
Performance Tests, 2-1
Absolute Power Accuracy, 2-41
Automated, 2-22
Broadband Frequency Response, 2-20
Dynamic Accuracy, 2-34
Dynamic Range, 2-13
Failures, 2-2
Frequency Range and Accuracy, 2-10
Manual Tests, 2-9
Operator's Check, 2-7
Power Range and Flatness, 2-16
Printing Test Results, 2-30
Recommended Test Equipment, 2-2
Running Automated Tests, 2-29
Spurious Signals, 2-31
System Directivity and Port Match, 2-45
Port Match and System Directivity Performance Test, 2-45
Power (Source) Correction Adjustment, 3-18
Power Accuracy Performance Test, 2-41
Power Holes, 2-18
Power Range, 2-17
Power Range and Flatness Performance Test, 2-16

Power Supply, 7-11
How to Remove, 7-11
Parts ID, 7-11
Theory of Operation, 6-2
Preventive Maintenance, 1-2
Printer, 2-22
Printers, Compatible, 2-23
Printing Performance Test Results, 2-30
Program Disk, 2-27

R

R* Amplitude Correction Adjustment, 3-24
R* Chan DAC, 5-7
R* Freq Response, 5-8
R* Frequency Response Correction Adjustment, 3-25
Rebuilt Parts, 7-1
Rebuilt-Exchange Assemblies, 7-1
Receiver Assembly, 7-9
How to Remove, 7-10
Parts ID, 7-9
Theory of Operation, 6-6
Receiver Characteristics, 2-4
Recession of Center Conductor, 1-2
Recommended Test Equipment, 2-2
Recover from an Error, 2-29
Reflection Correction Adjustment, 3-23
Restore Data Disp, 5-8
RF Connectors, How to Check, 1-2
RF Output Power, 2-4
Run the Performance Tests Program, 2-29
Running Software, 2-27

S

Sample, 5-9
SCPI Command Summary, 5-15
SCPI Commands, 5-14
SCPI Syntax, 5-14
Select Adjustment, 5-2
Select Node, 5-9
Select Self-Test, 5-2
Self-Tests, 5-2
Self-Tests for Troubleshooting, 4-9
Serial Number Adjustment, 3-11
Serial Number, to See on Screen, 5-6
Service Key Menus, 5-1
Service Manual, Organization of, 1-1
Service Modes, 5-5
Service Test Equipment, 1-3
Service Tools, Part Numbers, 7-16
Service Utilities Menu, 5-6
Set Attenuator, 5-7
Set Serial Number Adjustment, 3-11
Setting Up An Automated System, 2-22
Signal Purity, 2-5
Signal Purity Test Setup, 2-32
Software
Backup, 2-25
Copy from Flexible Disk to Flexible Disk, 2-26
Copy to a Hard Disk, 2-26

Copy to a High Density Flexible Disk, 2-26
Error Recovery, 2-29
Loading and Running, 2-27
Requirements, 2-23
Software, Part Numbers, 7-15
Source Assembly, 7-8
How to Remove, 7-8
Theory of Operation, 6-4
Source Characteristics, 2-4
Source Match, 5-8
Source Power Correction Adjustment, 3-18
Specifications, 2-4
Spurious Signals Automated Performance Test, 2-31
Spurs, How They're Avoided, 6-5
Stop Test, 5-2
Store CC to Disk, 5-9
Store CC to EPROM, 5-9
Sweep Time, 2-5
Switched Gain Correction Adjustment, 3-14
System Accuracy, 2-5
System Addresses, Automated, 2-24
System Directivity and Port Match Automated Performance Test, 2-45
System Theory, 6-1

T

Test Equipment, 1-3
Test Record, 2-57
Test Set Characteristics, 2-4
Test Software, 2-27
Tests and Adjustments Menu, 5-2
Tracking, 5-8
Transmission Correction Adjustment, 3-22
Troubleshooting
Centronics Printers and Plotters, 4-3
Detailed, 4-18
Digital Group Problems, 4-7
Disk Drives, 4-3
Front Panel Problems, 4-13
HP-IB Systems, 4-3
Incorrect Data Problems, 4-16
Peripheral Problems, 4-2
Phase Lock Problems, 4-13
Power Supply Problems, 4-5
Random Noise Trace, 4-16
Receiver Problems, 4-15
RS-232 Printers and Plotters, 4-2
Source Group Problems, 4-13
Source Power Problems, 4-14
Spurious Signals, 4-14
Spurs, 4-16
the Analyzer, 4-5
with Self-Tests, 4-9
Troubleshooting the 8711 System, 4-1

U

Update Corr Const Menu, 5-8
Upgrade Kits ID, 7-16

V

Verifying Instrument Performance, 2-1

Verifying Performance with Automated
Tests, 2-22

Verifying Performance with Manual
Tests, 2-9

View Array Interpol, 5-8

View Array Master, 5-8

View Array Menu, 5-8