

HP 8671B SYNTHESIZED CW GENERATOR 2.0—18.0 GHz

SERIAL NUMBERS

This manual applies directly to instruments with serial numbers prefixed 2545A.

For additional important information about serial numbers, see INSTRUMENTS COVERED BY MANUAL in Section I.

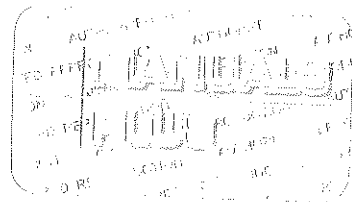

© Copyright HEWLETT-PACKARD COMPANY 1985, 1986
1501 PAGE MILL ROAD, PALO ALTO, CALIFORNIA, U.S.A.

OPERATING AND SERVICE MANUAL PART NUMBER 08671-90017
Operating Manual Part No. 08671-90019
Microfiche Part No. 08671-90018

Printed: JUNE 1986

CERTIFICATION

Hewlett-Packard Company certifies that this product met its published specifications at the time of shipment from the factory. Hewlett-Packard further certifies that its calibration measurements are traceable to the United States National Bureau of Standards, to the extent allowed by the Bureau's calibration facility, and to the calibration facilities of other International Standards Organization members.

WARRANTY

This Hewlett-Packard instrument product is warranted against defects in material and workmanship for a period of one year from date of shipment. During the warranty period, Hewlett-Packard Company will, at its option, either repair or replace products which prove to be defective.

For warranty service or repair, this product must be returned to a service facility designated by HP. Buyer shall prepay shipping charges to HP and HP shall pay shipping charges to return the product to Buyer. However, Buyer shall pay all shipping charges, duties, and taxes for products returned to HP from another country.

HP warrants that its software and firmware designated by HP for use with an instrument will execute its programming instructions when properly installed on that instrument. HP does not warrant that the operation of the instrument, or software, or firmware will be uninterrupted or error free.

LIMITATION OF WARRANTY

The foregoing warranty shall not apply to defects resulting from improper or inadequate maintenance by Buyer, Buyer-supplied software or interfacing, unauthorized modification or misuse, operation outside of the environmental specifications for the product, or improper site preparation or maintenance.

NO OTHER WARRANTY IS EXPRESSED OR IMPLIED. HP SPECIFICALLY DISCLAIMS THE IMPLIED WARRANTIES OF MERCHANTABILITY AND FITNESS FOR A PARTICULAR PURPOSE.

EXCLUSIVE REMEDIES

THE REMEDIES PROVIDED HEREIN ARE BUYER'S SOLE AND EXCLUSIVE REMEDIES. HP SHALL NOT BE LIABLE FOR ANY DIRECT, INDIRECT, SPECIAL, INCIDENTAL, OR CONSEQUENTIAL DAMAGES, WHETHER BASED ON CONTRACT, TORT, OR ANY OTHER LEGAL THEORY.

ASSISTANCE

Product maintenance agreements and other customer assistance agreements are available for Hewlett-Packard products.

For any assistance, contact your nearest Hewlett-Packard Sales and Service Office. Addresses are provided at the back of this manual.

CONTENTS

	Page		Page
Section I		Local Mode 3-17	
GENERAL INFORMATION		Addressing 3-17	
Introduction	1-1	Data Messages 3-17	
Specifications	1-1	Receiving Data Messages 3-19	
Safety Considerations	1-1	Receiving the Clear Message 3-19	
Instruments Covered by This Manual	1-1	Receiving the Trigger Message 3-20	
Manual Changes Supplement	1-1	Receiving the Remote Message 3-20	
Description	1-2	Receiving the Local Message 3-20	
Options	1-2	Receiving the Local Lockout Message 3-20	
Mechanical Options	1-2	Receiving the Clear Lockout/Set Local Message 3-20	
Accessories Supplied	1-2	Receiving the Pass Control Message 3-20	
Accessories Available	1-3	Sending the Require Service Message 3-20	
Electrical Equipment Available	1-3	Sending the Status Byte Message 3-20	
Recommended Test Equipment	1-3	Sending the Status Bit Message 3-20	
Section II		Receiving the Abort Message 3-20	
INSTALLATION		Operator's Checks 3-22	
Introduction	2-1	Basic Functional Checks 3-22	
Initial Inspection	2-1	HP-IB Checks 3-26	
Preparation For Use	2-1	Section IV	
Power Requirements	2-1	PERFORMANCE TESTS	
Line Voltage and Fuse Selection	2-1	Introduction 4-1	
Power Cables	2-1	Abbreviated Performance Test 4-1	
HP-IB Address Selection	2-2	Calibration Cycle 4-1	
Interconnections	2-3	Performance Test Record 4-1	
Mating Connectors	2-3	Equipment Required 4-1	
Operating Environment	2-3	Test Procedures 4-1	
Bench Operation	2-4	Frequency Range and Resolution Test 4-2	
Rack Mounting	2-4	Frequency Switching Time Test 4-5	
Storage and Shipment	2-4	Output Level, High Level Accuracy and Flatness Test 4-11	
Environment	2-4	Low Level Accuracy Test 4-16	
Packaging	2-4	Output Level Switching Time Test 4-20	
Section III		Harmonics, Subharmonics & Multiples Test 4-23	
OPERATION		Non-Harmonically Related Spurious Signals Test 4-26	
Introduction	3-1	Power Line Related Spurious Signals Test 4-28	
 Panel Features	3-1	Single-Sideband Phase Noise Test 4-31	
Operating Characteristics	3-1	Internal Time Base Aging Rate 4-36	
Local Operation	3-1	Section V	
Remote (HP-IB) Operation	3-1	ADJUSTMENTS	
Operator's Checks	3-1	Introduction 5-1	
Operator's Maintenance	3-1	Safety Considerations 5-1	
Turn-On Instructions	3-1	Equipment Required 5-1	
Turn-On	3-1	Factory Selected Components 5-1	
Frequency Standard Selection	3-1	Related Adjustments 5-1	
Simplified Operation	3-3	Power Supply Adjustments 5-5	
Frequency	3-3	10 MHz Reference Oscillator Adjustment 5-6	
Output Level	3-3	100 MHz VCXO Adjustment 5-7	
ALC	3-3	M/N VCO Adjustment 5-10	
ALC Control	3-4	20/30 Divider Bias Adjustment 5-13	
Frequency Control	3-8	160—240 MHz VCO Pretune Adjustment 5-15	
Level Control	3-12	20/30 Phase Detector Notch Filter Adjustment 5-17	
Peak-Norm Adjustment	3-15		
RF ON/OFF Switch	3-16		
Remote (HP-IB) Operation	3-17		
HP-IB Compatibility	3-17		
Remote Mode	3-17		

CONTENTS (cont'd)

	Page		Page
YTO Pretune Digital-to Analog		Service Sheets	8-2
Converter Adjustment	5-19	Manual Backdating (†)	8-2
YTO Driver Adjustment	5-21	Manual Updating	
YTO Sampler Adjustment	5-22	(Manual Changes Supplement)	8-2
YTO Phase Detector Adjustment	5-25	Safety Considerations	8-2
YTM Adjustment	5-28	Before Applying Power	8-2
Power Clamp Adjustment	5-33	Warnings and Cautions	8-2
ALC Adjustments	5-34	After Service Safety Checks	8-3
Flatness Adjustment	5-36	Recommended Test Equipment	8-3
External Leveling Adjustment	5-37	Service Tools, Aids, and Information	8-3
Section VI			
REPLACEABLE PARTS			
Introduction	6-1	Service Accessories	8-3
Restored Assemblies	6-1	Poizdriv Screwdrivers	8-3
Abbreviations	6-1	Tuning Tools	8-3
Replaceable Parts List	6-1	Hardware	8-3
Factory Selected Parts (*)	6-1	Assembly Locations	8-3
Parts List Backdating (†)	6-1	Parts and Cable Locations	8-12
Parts List Updating	6-1	Test Points and Adjustment Locations	8-12
Ordering Information	6-1	Service Aids on Printed Circuit Boards	8-12
Parts Identification	6-2	Other Service Documents	8-12
Recommended Spares List	6-2	Repair and Replacement	8-12
Section VII			
MANUAL CHANGES			
Introduction	7-1	After Repair Adjustment Procedure	8-12
Instrument Improvement Modifications	7-1	Disassembly and Reassembly Procedures	8-12
Section VIII			
SERVICE			
Introduction	8-1	Top and Bottom Cover Removal	8-12
Failure Modes and Service Strategy	8-1	Etched Circuits (Printed Circuit Boards)	8-12
General	8-1	Electrostatic Discharge (ESD) Precautions	8-13
Turn-on Errors	8-1	Module Exchange Program	8-14
Operator Errors	8-1	Non-Repairable Assemblies	8-14
Instrument Performance Out of Specification	8-1	Factory Selected Components (*)	8-14
Catastrophic Failures	8-1	Cleaning	8-14
		Cleaning Intervals	8-14
		Cleaning Solution	8-14
		Top Cover Removal and Replacement	8-14
		6-Month Cleaning	8-14
		12-Month Cleaning	8-15
		Schematic Symbology	8-16
		Basic Logic Symbology	8-16
		Complex Device Symbology	8-17

SERVICE SHEETS

Service Sheet		Service Sheet	Page
BD1 Overall Block Diagram		1 Reference Phase Detector Assembly	8-69
and Troubleshooting	8-23	2 100 MHz VCXO Assembly	8-74
BD2 Time Base Reference	8-32	3 M/N Phase Detector Assembly	8-76
BD3 RF Phase Locked Loops	8-34	4 M/N VCO Assembly	8-80
BD4 YTO Summing Phase Locked Loop	8-44	5 M/N Output Assembly	8-82
BD5 Microwave Signal Path	8-46	6 20/30 Divider Assembly	8-84
BD6 Automatic Level Control (ALC)	8-50	7 20/30 MHz Phase Detector Assembly	8-86
BD7 DCU Remote/Local Interface	8-52	8 VCO 160–240 MHz Assembly	8-88
BD8 DCU HP-IB Interface	8-54	9 Digital to Analog Converter Assembly	8-90
BD9 DCU Frequency Control	8-56	10 YTO Driver Assembly	8-92
BD10 Power Supplies	8-66	11 YTO Sampler Assembly	8-95

CONTENTS (cont'd)

SERVICE SHEETS (cont'd)

Service Sheet	Page	Service Sheet	Page
12 YTO Phase Detector Assembly	8-98	26 Register 1 Assembly	8-126
13 YTO/HF Coil Driver Assembly	8-100	27 P/O Timing and Control Assembly	8-128
14 RF Amplifier and ALC Assembly	8-102	28 P/O Timing and Control Assembly	8-130
15 YTM Control	8-104	29 P/O Output Register Assembly	8-132
16 SRD Control Circuits	8-106	30 P/O Output Register Assembly	8-134
17 ALC Detector Assembly	8-108	31 P/O DCU Front Panel Assembly	8-137
18 RF Output Level Control Assembly	8-110	32 P/O DCU Front Panel Assembly	8-140
19 Digital Processor Assembly	8-112	33 Rectifier Assembly	8-142
20 RF Front Panel Controls and Displays	8-114	34 Positive Regulator Assembly	8-144
22 P/O HP-IB Address Assembly	8-117	35 Negative Regulator Assembly	8-146
23 P/O HP-IB Address Assembly	8-120	A Disassembly and Reassembly	
24 P/O HP-IB Interface Assembly	8-122	Procedures	8-149
25 P/O HP-IB Interface Assembly	8-124	B Internal Views	8-151

ILLUSTRATIONS

Figure	Page	Figure	Page
1-1. HP Model 8671B Accessories Supplied, and Options 907, 908, and 909	1-0	4-9. Harmonics, Subharmonics, and Multiples Test Setup	4-23
2-1. Line Voltage and Fuse Selection	2-2	4-10. Non-Harmonically Related Spurious Signals Test Setup	4-26
2-2. Power Cable and Mains Plug Part Numbers	2-2	4-11. Power Line Related Spurious Signals Test Setup	4-29
2-3. HP-IB Address Switches Shown as Set by the Factory	2-3	4-12. Single-Sideband Phase Noise Test Setup ..	4-32
2-4. Hewlett-Packard Interface Bus Connection	2-5	4-13. Internal Time Base Aging Rate Test Setup	4-36
 3-1. Front Panel Features	3-2	5-1. 10 MHz Reference Oscillator Adjustment Test Setup	5-6
3-2. Rear Panel Features	3-2	5-2. 100 MHz VCXO Adjustment Test Setup	5-7
3-3. External Leveling with a Crystal Detector ..	3-4	5-3. M/N VCO Adjustment Test Setup	5-10
3-4. External Leveling with a Power Meter	3-5	5-4. 20/30 Divider Bias Adjustment Test Setup	5-13
3-5. Frequency Programming Codes and Arguments	3-10	5-5. 20/30 Phase Detector Notch Filter Adjustment Test Setup	5-17
3-6. Frequency Switching Time Showing Worst Case	3-11	5-6. YTO Loop Sampler Adjustment Test Setup	5-22
3-7. Frequency Checks Test Setup	3-23	5-7. YTO Sampler Frequency Response	5-23
4-1. Frequency Range and Resolution Test Setup	4-2	5-8. YTO Phase Detector Adjustment Test Setup	5-25
4-2. Frequency Switching Time Test Setup	4-6	5-9. Special Interconnect Cable	5-25
4-3. Frequency Switching Time Measurement Waveform	4-8	5-10. Spectrum Analyzer Display of Phase Locked Loop Gain	5-26
4-4. Amplitude Recover Measurement Waveform	4-10	5-11. YTM Adjustment Test Setup	5-28
4-5. Output Level, High Level Accuracy and Flatness Test Setup	4-12	5-12. Optimum Centered YTM Response	5-30
4-6. Low Level Accuracy Test Setup	4-17	5-13. Optimum Offset YTM Response	5-31
4-7. Output Level Switching Time Test Setup ..	4-20	5-14. External Leveling Adjustment Test Setup	5-37
4-8. Output Level Switching Time Measurement Waveform	4-22	6-1. Cabinet Illustrated Parts Breakdown	6-70

ILLUSTRATIONS (cont'd)

Figure	Page	Figure	Page
6-2. Cabinet and Frame Illustrated		8-25. ALC Block Diagram	8-51
Parts Breakdown	6-71	8-26. Remote/Local Interface Block Diagram	8-53
6-3. Overall Illustrated Parts Breakdown	6-72	8-27. DCU HP-IB Interface Block Diagram	8-55
6-4. Front Panel Photo, Front View	6-73	8-28. A2A11 CLK 1 Test Point	8-56
6-5. RF Front Panel Inside View (Left Side)	6-74	8-29. A2A11 CLK 2 Test Point	8-56
6-6. DCU Front Panel Inside View		8-30. XA2A11C-7, NCLK 2	8-56
(Right Side)	6-75	8-31. XA2A11A-30, NCLK 3	8-56
6-7. A1 Card Cage Illustrated Parts		8-32. XA2A11B-30, LEFT	8-56
Breakdown	6-76	8-33. XA2A11A-19, CYCLE	8-56
6-8. A1 Microwave Circuits Illustrated		8-34. XA2A11C-1, GO	8-56
Parts Breakdown	6-77	8-35. XA2A10C-20, NERR	8-58
6-9. A3 Power Supply and RF Source		8-36. A2A10 HNR1 Test Point	8-58
Illustrated Parts Breakdown	6-78	8-37. A2A10 HNR2 Test Point	8-58
6-10. A3 RF Source Illustrated		8-38. DR101, DR102	8-59
Parts Breakdown	6-79	8-39. XA2A8B-11, NRMDR	8-61
6-11. A3 Rear Panel Illustrated		8-40. A2A8U23, BCD8	8-61
Parts Breakdown	6-80	8-41. A2A8U23-15, BCD4	8-61
6-12. A3 Power Supply and Rear Panel		8-42. A2A8U23-13, BCD2	8-62
Illustrated Parts Breakdown	6-81	8-43. A2A8U23-14, BCD1	8-62
6-13. A3 Fan Assembly Illustrated		8-44. A2A8U23-7, DR218	8-62
Parts Breakdown	6-82	8-45. A2A8U23-3, DR214	8-62
6-14. P/O A2 Controller Assembly and Rear		8-46. A2A8U23-4, DR212	8-63
Panel Illustrated Parts Breakdown	6-83	8-47. A2A8U23-9, DR211	8-63
6-15. P/O A2 Controller Assembly Illustrated		8-48. DCU Frequency Control Block Diagram	8-65
Parts Breakdown	6-84	8-49. Power Supply Block Diagram	8-67
6-16. A3A9 YTO and Reference Oscillator		8-50. A3A1A6 Reference and M/N Motherboard	
Illustrated Parts Breakdown	6-85	Assembly Component Locations	8-71
8-1. Basic Logic Symbols and Qualifiers	8-18	8-51. A3A1A1 Reference Phase Detector Assembly	
8-2. Indicator Symbols	8-19	Component and Test Point Locations	8-72
8-3. Contiguous Blocks	8-20	8-52. Reference Phase Detector Assembly	
8-4. AND Dependency Notation	8-20	Schematic Diagram	8-73
8-5. Address Dependency Notation	8-20	8-53. A3A1A2 100 MHz VCXO Assembly	
8-6. OR and Free Dependency Notation	8-21	Component and Test Point Locations	8-75
8-7. Common Control Block	8-21	8-54. 100 MHz VCXO Assembly	
8-8. Quad D-Type Latch (Combined)	8-21	Schematic Diagram	8-75
8-9. Quad D-Type Latch (Individual)	8-21	8-55. Divider Operation Timing Diagram	8-76
8-10. Shift Register	8-22	8-56. Divider Clock Pulses versus Output	
8-11. AND-OR Selector	8-22	Pulses Timing Diagram	8-76
8-12. UP-DOWN Counter	8-22	8-57. A3A1A3TP2 and TP3 Waveforms	8-76
8-13. Quad D-Type Latch	8-22	8-58. A3A1A3 M/N Phase Detector Assembly	
8-14. Major Assemblies	8-23	Component and Test Point Locations	8-79
8-15. Overall Troubleshooting Block Diagram	8-31	8-59. M/N Phase Detector Assembly	
8-16. Time Base Reference Block Diagram	8-33	Schematic Diagram	8-79
8-17. 80 kHz Reference, A2A5TP2	8-39	8-60. A3A1A3 M/N Phase Detector Assembly	
8-18. A2A5TP3, A2A3S1 Test Switch HIGH	8-39	Component and Test Point Locations	8-81
8-19. RF Phase Locked Loops Block Diagram	8-43	8-61. M/N VCO Assembly	
8-20. YTO Summing Loop Block Diagram	8-45	Schematic Diagram	8-81
8-21. YTM Simplified Schematic	8-46	8-62. A3A1A5 M/N Output Assembly	
8-22. Band 1 Squegging	8-46	Component and Test Point Locations	8-83
8-23. Typical YTM Output Power	8-46	8-63. M/N Output Assembly	
8-24. Microwave Signal Path Block Diagram	8-49	Schematic Diagram	8-83
		8-64. A2A5 20/30 Divider Assembly	
		Component and Test Point Locations	8-85

ILLUSTRATIONS (cont'd)

Figure	Page	Figure	Page
8-65. 20/30 Divider Assembly Schematic Diagram	8-85	8-92. A1A10 RF Output Level Control Component Locations	8-111
8-66. Phase Detector Timing	8-86	8-93. RF Output Level Control Schematic Diagram	8-111
8-67. A2A4 20/30 Phase Detector Assembly Component and Test Point Locations ...	8-87	8-94. A1A11 Digital Processor Assembly Component, Adjustment and Test Point Locations	8-113
8-68. 20/30 Phase Detector Assembly Schematic Diagram	8-87	8-95. Digital Processor Schematic Diagram ...	8-113
8-69. A2A3 VCO 160—240 MHz Assembly Component and Test Point Locations ...	8-89	8-96. A1A2 Display Driver Assembly Component Locations	8-115
8-70. VCO 160—240 MHz Assembly Schematic Diagram	8-89	8-97. A1A1 RF Output Front Panel Assembly Component Locations	8-115
8-71. A3A5 DAC Assembly Component and Test Point Locations	8-91	8-98. RF Front Panel Controls and Displays Schematic Diagram	8-115
8-72. Digital-to-Analog Converter Assembly Schematic Diagram	8-91	8-99. HP-IB Handshake Waveforms	8-119
8-73. YTO Frequency versus Coil Drive Current	8-92	8-100. A2A9 HP-IB Address Assembly Component Location	8-119
8-74. A3A6 YTO Driver Assembly Component and Test Point Locations	8-92	8-101. P/O HP-IB Address Schematic Diagram	8-119
8-75. YTO Driver Assembly Schematic Diagram	8-93	8-102. A2A9 P/O HP-IB Address Assembly Component Locations	8-121
8-76. A3A9A5 Sampler Assembly Component and Test Point Locations ...	8-97	8-103. P/O HP-IB Address Assembly Schematic Diagram	8-121
8-77. YTO Sampler Assembly Schematic Diagram	8-97	8-104. P/O A2A7 Interface Assembly Component and Test Point Locations	8-123
8-78. A3A9A4 Phase Detector Assembly Component and Test Point Locations ...	8-99	8-105. P/O HP-IB Interface Assembly Schematic Diagram	8-123
8-79. P/O YTO Phase Detector Assembly Schematic Diagram	8-99	8-106. P/O A2A7 Interface Assembly Component Locations	8-125
8-80. A3A7 YTO/HF Coil Driver Assembly Component and Test Point Locations ..	8-101	8-107. P/O HP-IB Interface Schematic Diagram	8-125
8-81. YTO/HF Coil Driver Assembly Schematic Diagram	8-101	8-108. A2A10 Register 1 Assembly Component Locations	8-127
8-82. A1A5 ALC Assembly Component Locations	8-103	8-109. Register 1 Assembly Schematic Diagram	8-127
8-83. A1A13 Interconnect Assembly Component Locations	8-103	8-110. P/O A2A11 Timing and Control Assembly Component Locations	8-129
8-84. RF Amplifier and P/O ALC Schematic Diagram	8-103	8-111. P/O Timing and Control Assembly Schematic Diagram	8-129
8-85. A1A3 YTM Assembly Component and Test Point Locations	8-105	8-112. P/O A2A11 Timing and Control Assembly Component and Test Point Locations	8-131
8-86. A1A8 YTM Driver Assembly Component, Adjustment and Test Point Locations ..	8-105	8-113. P/O Timing and Control Assembly Schematic Diagram	8-131
8-87. YTM Control Schematic Diagram	8-105	8-114. P/O A2A8 Output Register Assembly Component and Test Point Locations	8-133
8-88. A1A7 SRD Bias Assembly, Component Locations	8-107	8-115. Output Register Assembly Schematic Diagram	8-133
8-89. 16 SRD Bias Assembly Schematic Diagram	8-107	8-116. P/O A2A8 Output Register Assembly Component and Test Point Locations	8-135
8-90. A1A6 ALC Detector Assembly Component, Adjustment and Test Point Locations ..	8-109		
8-91. ALC Detector Assembly Schematic Diagram	8-109		

ILLUSTRATIONS (cont'd)

Figure	Page	Figure	Page
8-117. P/O Output Register Assembly Schematic Diagram	8-135	8-125. Positive Regulator Assembly Schematic Diagram	8-145
8-118. P/O A2A1 Front Panel Assembly Component Locations	8-139	8-126. A3A4 Negative Regulator Assembly Component Locations	8-147
8-119. P/O DCU Front Panel Assembly Schematic Diagram	8-139	8-127. A3A4 Negative Regulator Assembly Schematic Diagram	8-147
8-120. P/O A2A1 DCU Front Panel Assembly Component Locations	8-141	8-128. Transformer and Filter Capacitor Removal	8-149
8-121. P/O DCU Front Panel Assembly Schematic Diagram	8-141	8-129. A1 RF Output Assembly, Amplifier, Attenuator and YTM	8-150
8-122. A3A2 Rectifier Assembly Component and Test Point Locations	8-143	8-130. YTO Assembly in Service Position	8-150
8-123. Rectifier Assembly Schematic Diagram	8-143	8-131. Top View, Assembly Location	8-151
8-124. A3A3 Positive Regulator Assembly Component and Test Point Locations	8-145	8-132. Top View, Component Location Covers Removed	8-151
		8-133. Bottom View, Component Location	8-151

TABLES

Table	Page	Figure	Page
1-1. Specifications	1-4	6-2. Replaceable Parts	6-5
1-2. Supplemental Characteristics	1-7	6-3. Code List of Manufacturers	6-86
1-3. Recommended Test Equipment	1-8		
2-1. Allowable HP-IB Address Codes	2-3	8-1. Schematic Diagram Notes	8-4
3-1. Operating Characteristics	3-1	8-2. Etched Circuit Soldering Equipment	8-13
3-2. Index of Detailed Operating Instructions ...	3-1	8-3. M and N Numbers and Resulting Frequencies	8-34
3-3. Message Reference Table	3-18	8-4. LFS 1K—8M Inputs	8-40
3-4. Programming Quick Reference Guide	3-21	8-5. LFS 1K—8M Outputs	8-40
4-1. Output Level, High Level Accuracy and Flatness Test Record	4-14	8-6. M1—M5 and N1—N6 Inputs	8-41
4-2. Low Level Accuracy Test Record	4-19	8-7. M1—M5 and M1—N6 Outputs	8-41
4-3. Harmonics, Subharmonics & Multiples Test Record	4-25	8-8. DAC 1 — 4800 MHz Inputs	8-44
4-4. Performance Test Record	4-38	8-9. DAC 1 — 4800 MHz Outputs	8-44
5-1. Factory Selected Components	5-2	8-10. Frequency Bands	8-46
5-2. Performance Test Failure and Required Action	5-2	8-11. YTM Control Inputs	8-46
5-3. Post-Repair Adjustments	5-3	8-12. YTM Control Band Inputs	8-46
6-1. Part Numbers for Exchange Assemblies	6-2	8-13. HN1 and HN2 Inputs	8-47
		8-14. Frequency Band Outputs	8-58
		8-15. Register 1 Serial Output	8-60
		8-16. Register 1 Serial Input	8-60
		8-17. M1—M5 and N1—N6 Outputs	8-63
		8-18. LFS 1K—8M Outputs	8-64
		8-19. Divider Operation	8-77
		8-20. Increment Decoder Operation	8-77

SAFETY CONSIDERATIONS

GENERAL

This product and related documentation must be reviewed for familiarization with safety markings and instructions before operation.

This product is a Safety Class I instrument (provided with a protective earth terminal).

BEFORE APPLYING POWER

Verify that the product is set to match the available line voltage and the correct fuse is installed.

SAFETY EARTH GROUND

An uninterruptible safety earth ground must be provided from the main power source to the product input wiring terminals, power cord, or supplied power cord set.

WARNINGS

Any interruption of the protective (grounding) conductor (inside or outside the instrument) or disconnecting the protective earth terminal will cause a potential shock hazard that could result in personal injury. (Grounding one conductor of a two conductor outlet is not sufficient protection.) In addition, verify that a common ground exists between the unit under test and this instrument prior to energizing either unit.

Whenever it is likely that the protection has been impaired, the instrument must be made inoperative and be secured against any unintended operation.

If this instrument is to be energized via an auto-transformer (for voltage reduction) make sure the common terminal is connected to neutral (that is, the grounded side of the mains supply).

Servicing instructions are for use by service-trained personnel only. To avoid dangerous electric shock, do not perform any servicing unless qualified to do so.

Adjustments described in the manual are performed with power supplied to the instrument

while protective covers are removed. Energy available at many points may, if contacted, result in personal injury.

Capacitors inside the instrument may still be charged even if the instrument has been disconnected from its source of supply.

For continued protection against fire hazard, replace the line fuse(s) only with 250V fuse(s) of the same current rating and type (for example, normal blow, time delay, etc.). Do not use repaired fuses or short circuited fuseholders.

SAFETY SYMBOLS



Instruction manual symbol: the product will be marked with this symbol when it is necessary for the user to refer to the instruction manual (see Table of Contents for page references).



Indicates hazardous voltages.



Indicates earth (ground) terminal.

WARNING

The WARNING sign denotes a hazard. It calls attention to a procedure, practice, or the like, which, if not correctly performed or adhered to, could result in personal injury. Do not proceed beyond a WARNING sign until the indicated conditions are fully understood and met.

CAUTION

The CAUTION sign denotes a hazard. It calls attention to an operating procedure, practice, or the like, which, if not correctly performed or adhered to, could result in damage to or destruction of part or all of the product. Do not proceed beyond a CAUTION sign until the indicated conditions are fully understood and met.

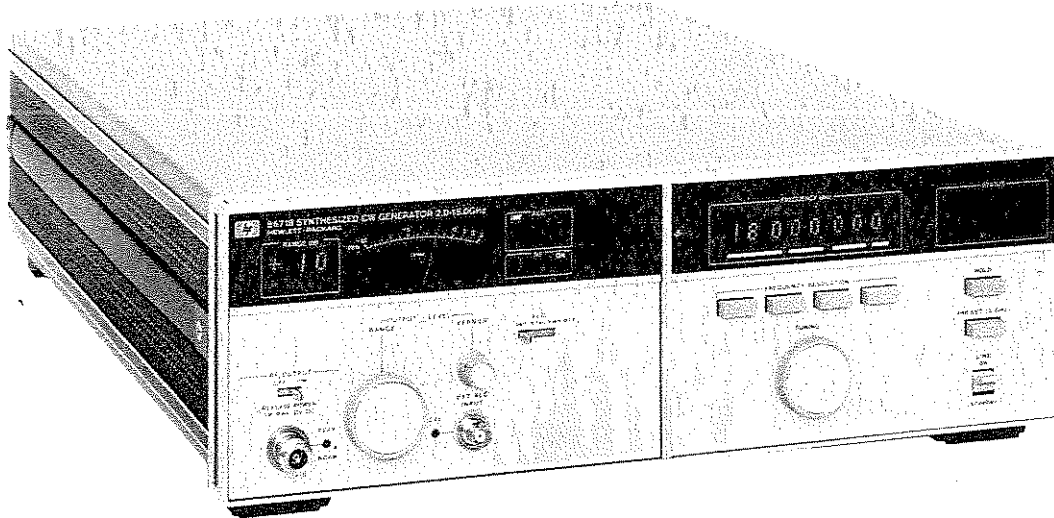

HP 8671B

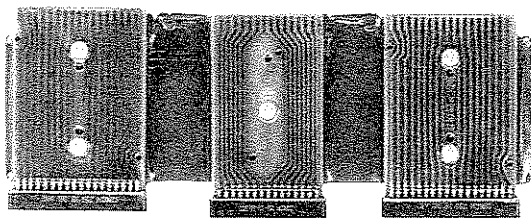

EXTENDER BOARDS

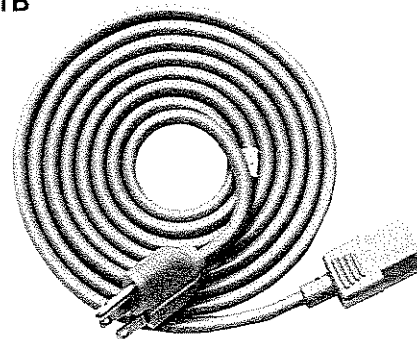

LINE POWER CABLE

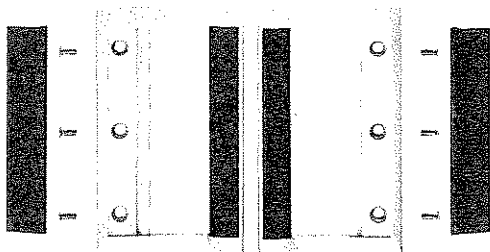

OPTION 907
FRONT HANDLE KIT

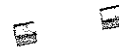

FUSE

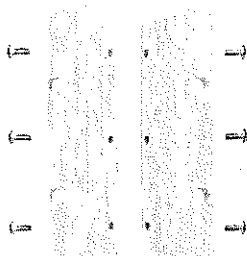

OPTION 908
RACK FLANGE KIT

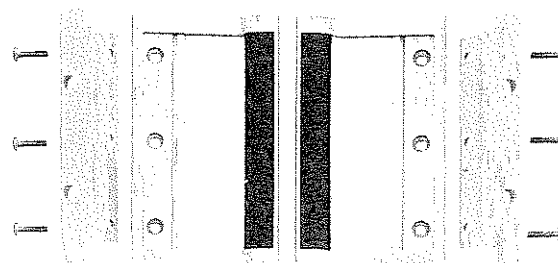

OPTION 909
RACK FLANGE AND FRONT
HANDLE COMBINATION KIT

Figure 1-1. HP Model 8671B Accessories Supplied, and Options 907, 908, and 909

SECTION I GENERAL INFORMATION

1-1. INTRODUCTION

This manual contains information required to install, operate, test, adjust and service the Hewlett-Packard 8671B Synthesized CW Generator. Figure 1-1 shows the CW Generator with all of its externally supplied accessories.

The 8671B Operating and Service manual has eight sections. The subjects addressed are:

- Section I, General Information
- Section II, Installation
- Section III, Operation
- Section IV, Performance Tests
- Section V, Adjustments
- Section VI, Replaceable Parts
- Section VII, Manual Changes
- Section VIII, Service

Two copies of the operating information are supplied with the CW Generator. One copy is in the form of an Operating Manual. The Operating Manual is a copy of the first four sections of the Operating and Service Manual. The Operating Manual should stay with the instrument for use by the operator. Additional copies of the Operating Manual can be ordered separately through your nearest Hewlett-Packard office. The part number is listed on the title page of this manual.

Also listed on the title page of this manual, below the manual part number, is a microfiche part number. This number may be used to order 100 x 150 millimetre (4 x 6 inch) microfilm transparencies of this manual. Each microfiche contains up to 96 photo-duplicates of the manual pages. The microfiche package also includes the latest Manual Changes supplement, as well as all pertinent Service Notes.

1-2. SPECIFICATIONS

Instrument specifications are listed in Table 1-1. These specifications are the performance standards or limits against which the instrument may be tested. Supplemental characteristics are listed in Table 1-2. Supplemental characteristics are not warranted specifications, but are typical characteristics included as additional information for the user.

1-3. SAFETY CONSIDERATIONS

This product is a Safety Class I instrument, that is, one provided with a protective earth terminal. The CW Generator and all related documentation should be reviewed for familiarization with safety markings and instructions before operation. Refer to the Safety Considerations page found at the beginning of this manual for a summary of the safety information. Safety information for installation, operation, performance testing, adjustment, or service is found in appropriate places throughout this manual.

1-4. INSTRUMENTS COVERED BY THIS MANUAL

Attached to the rear panel of the instrument is a serial number plate. The serial number is in the form: 0000A00000. The first four digits and the letter are the serial number prefix. The last five digits are the suffix. The prefix is the same for identical instruments; it changes only when a configuration change is made to the instrument. The suffix however, is assigned sequentially and is different for each instrument. The contents of this manual apply directly to instruments having the serial number prefix(es) listed under SERIAL NUMBERS on the title page.

1-5. MANUAL CHANGES SUPPLEMENT

An instrument manufactured after the printing of this manual may have a serial number prefix that is not listed on the title page. This unlisted serial number prefix indicates that the instrument is different from those documented in this manual. The manual for this newer instrument is accompanied by a Manual Changes supplement. The supplement contains "change information" that explains how to adapt this manual to the newer instrument.

In addition to change information, the supplement may contain information for correcting errors in the manual. To keep the manual as current and as accurate as possible, Hewlett-Packard recommends that you periodically request the latest Manual Changes supplement. The supplement is identified with the manual print date and part number, both

MANUAL CHANGES SUPPLEMENT (cont'd)

of which appear on the manual title page. Complimentary copies of the supplement are available from Hewlett-Packard.

For information concerning a serial number prefix that is not listed on the title page or in the Manual Changes supplement, contact your nearest Hewlett-Packard office.

1-6. DESCRIPTION

The HP 8671B Synthesized CW Generator has a frequency range of 2.0 to 18.0 GHz. The output is leveled and calibrated from +8 dBm to -120 dBm. Frequency, output level, and ALC modes can be remotely programmed via HP-IB.

The frequency can be tuned with one of four frequency resolutions. Tuning resolutions of 100 MHz, 1 MHz, 10 kHz or 1 kHz are selected by front panel pushbuttons. The 1 kHz tuning resolution will give tuning resolutions of 1 kHz for frequencies from 2.0 to 6.2 GHz, 2 kHz for frequencies from 6.2 to 12.4 GHz, and 3 kHz for frequencies from 12.4 to 18.599997 GHz.

Long-term frequency stability is dependent on the time base, either an internal or external reference oscillator. The internal crystal reference oscillator operates at 10 MHz while an external oscillator may operate at 5 or 10 MHz.

The output of the CW Generator is exceptionally flat due to the action of the internal automatic leveling control (ALC) loop. External leveling control using a diode detector or a power meter to sense output power can be used to level the output at a remote load.

The output level is set using the OUTPUT LEVEL RANGE switch and the OUTPUT LEVEL VERNIER. The OUTPUT LEVEL RANGE switch changes the output level in 10 dB increments (+10 to -110 dB). The OUTPUT LEVEL VERNIER is then used to adjust the output level over a continuous 13 dB range (-10 to +3 dBm). The output level is read by adding the vernier setting to the range setting.

The CW Generator is compatible with HP-IB to the extent indicated by the following codes: SH1, AH1, T6, TE0, L4, LE0, SR1, RL2, PP2, DC1, DT0, and C0. An explanation of the compatibility code can be found in IEEE Standard 488 (1978),

"IEEE Standard Digital Interface for Programmable Instrumentation" or the identical ANSI Standard MC1.1. For more detailed information relating to programmable control of the CW Generator, refer to Remote Operation, Hewlett-Packard Interface Bus in Section III of this manual.

1-7. OPTIONS**1-8. Mechanical Options**

The following options may have been ordered and received with the CW Generator. If they were not ordered with the original shipment and are now desired, they can be ordered from the nearest Hewlett-Packard office using the part numbers included in each of the following paragraphs.

Option 907 (Front Handle Kit). Ease of handling is increased with the front panel handles. The Front Handle Kit part number is 5061-9689.

Option 908 (Rack Flange Kit). The CW Generator can be solidly mounted to the instrument rack using the flange kit. The Rack Flange Kit part number is 5061-9677.

Option 909 (Rack Flange and Front Handle Combination Kit). This is a unique part which combines both functions. It is not simply a front handle kit and a rack flange kit packaged together. The Rack Flange and Front Panel Combination Kit part number is 5061-9683.

1-9. ACCESSORIES SUPPLIED

The accessories supplied with the CW Generator are shown in Figure 1-1.

a. The line power cable is supplied in several configurations, depending on the destination of the original shipment. Refer to Power Cables in Section II of this manual.

b. An additional fuse is shipped only with instruments that are factory configured for 100/120 Vac operation. This fuse has a 1.5A rating and is for reconfiguring the instrument for 220/240 Vac operation.

c. Four extender boards are supplied for performance testing, adjusting, and troubleshooting the instrument.

1. One 30-pin (15 x 2) extender board, HP part number 08672-60117.

ACCESSORIES SUPPLIED (cont'd)

2. Two 36-pin (18 x 2) extender boards, HP part number 08672-60020.
3. One 3-section, 30-pins (15 x 2) per section, extender board, HP part number 08672-60016 (for use in the A2 Assembly).

1-10. ACCESSORIES AVAILABLE

Chassis Slide Mount Kit. This kit is not available as a factory installed option. However, it is extremely useful when the CW Generator is rack mounted. Access to internal circuits and components or the rear panel is possible without removing the CW Generator from the rack. Order HP part number 1494-0059. If the instrument rack mounting slides are to be mounted in a standard EIA rack, then an adapter (HP Part No. 1494-0061) is needed. The slides without the adapter can be directly mounted in the HP system enclosures.

1-11. ELECTRICAL EQUIPMENT AVAILABLE

The CW Generator has an HP-IB interface and can be used with any HP-IB compatible computing controller or computer for automatic systems applications.

The HP-IB Controller is needed for performance testing. Controllers that are supported by this manual include the HP 9826A, 9836A, and HP 85B/82937A.

The HP 11712A Support Kit is available for maintaining and servicing the CW Generator. It includes a special test extender board, cables and adapters.

1-12. RECOMMENDED TEST EQUIPMENT

Table 1-3 lists the test equipment recommended for testing, adjusting and servicing the CW Generator. Essential requirements for each piece of test equipment are described in the Critical Specifications column. Other equipment can be substituted if it meets or exceeds these critical specifications.

Table 1-1. Specifications (1 of 3)

Note: Specifications apply after 1-hour warm-up, over the temperature range 0 to 55°C (except specifications for RF output level which apply over the range 15 to 35° C). Specifications for output flatness and absolute level accuracy apply only when internal leveling is used.		
Electrical Characteristics	Performance Limits	Conditions
FREQUENCY		
Range	2.0—18.0 GHz (Overrange to 18.599997 GHz)	
Resolution	1 kHz 2 kHz 3 kHz	2.0 to 6.2 GHz 6.2 to 12.4 GHz 12.4 to 18.0 GHz
Accuracy and Stability	Same as reference oscillator	
Switching Time		
Frequency (to be within the specified resolution ±1 kHz in 2.0 to 6.2 GHz range, etc.)	<15 ms	
Amplitude (after switching frequency) to be within ±3 dB of final level	<15 ms	When switching within the same frequency resolution band.
Reference Oscillator		
Frequency	10 MHz	
Aging Rate	<5 x 10 ⁻¹⁰ /day	After a 10 day warmup (typically 24 hours in a normal operating environment)
SPECTRAL PURITY		
Single-sideband Phase Noise		
2.0—6.2 GHz	<-58 dBc <-70 dBc <-78 dBc <-86 dBc <-110 dBc	1 Hz bandwidth 10 Hz offset from carrier 100 Hz offset from carrier 1 kHz offset from carrier 10 kHz offset from carrier 100 kHz offset from carrier
6.2—12.4 GHz	<-52 dBc <-64 dBc <-72 dBc <-80 dBc <-104 dBc	10 Hz offset from carrier 100 Hz offset from carrier 1 kHz offset from carrier 10 kHz offset from carrier 100 kHz offset from carrier
12.4—18.0 GHz	<-48 dBc <-60 dBc <-68 dBc <-76 dBc <-100 dBc	10 Hz offset from carrier 100 Hz offset from carrier 1 kHz offset from carrier 10 kHz offset from carrier 100 kHz offset from carrier
Harmonics	<-25 dBc	At +8 dBm

Table 1-1. Specifications (2 of 3)

Electrical Characteristics	Performance Limits	Conditions
<p>SPECTRAL PURITY (cont'd)</p> <p>Subharmonics and multiples thereof</p> <p>Spurious Signals, non-harmonically related, except power line and fan rotation related</p> <p>Power line related and fan rotation related within 5 Hz below line frequencies and multiples thereof 2.0—6.2 GHz</p> <p>6.2—12.4 GHz</p> <p>12.4—18.0 GHz</p>	<p><−25 dBc</p> <p><−70 dBc <−64 dBc <−60 dBc</p> <p><−50 dBc <−60 dBc <−65 dBc</p> <p><−44 dBc <−54 dBc <−59 dBc</p> <p><−40 dBc <−50 dBc <−55 dBc</p>	<p>2.0—6.2 GHz 6.2—12.4 GHz 12.4—18.0 GHz</p> <p><300 Hz offset from carrier 300 Hz to 1 kHz offset from carrier >1 kHz offset from carrier</p> <p><300 Hz offset from carrier 300 Hz to 1 kHz offset from carrier >1 kHz offset from carrier</p> <p><300 Hz offset from carrier 300 Hz to 1 kHz offset from carrier >1 kHz offset from carrier</p>
<p>RF OUTPUT</p> <p>Output Power</p> <p>Remote Programming Absolute Level Accuracy 2.0—6.2 GHz</p> <p>6.2—12.4 GHz</p> <p>12.4—18.0 GHz</p>	<p>+8 dBm to −120 dBm</p> <p>±1.00 dB ±1.00 dB ±1.50 dB ±1.70 dB ±1.90 dB ±1.90 dB & ±0.3 dB per 10 dB step</p> <p>±1.25 dB ±1.25 dB ±1.75 dB ±1.95 dB ±2.15 dB ±2.15 dB & ±0.3 dB per 10 dB step</p> <p>±1.50 dB ±1.50 dB ±2.10 dB ±2.30 dB ±2.40 dB ±2.40 dB & ±0.4 dB per 10 dB step</p>	<p>+15 to +35°C</p> <p>+10 dB output level range 0 dB output level range −10 dB output level range −20 dB output level range −30 dB output level range <−30 dB output level range</p> <p>+10 dB output level range 0 dB output level range −10 dB output level range −20 dB output level range −30 dB output level range <−30 dB output level range</p> <p>+10 dB output level range 0 dB output level range −10 dB output level range −20 dB output level range −30 dB output level range <−30 dB output level range</p>

Table 1-1. Specifications (3 of 3)

Electrical Characteristics	Performance Limits	Conditions
<p>RF OUTPUT (cont') Manual Absolute Level Accuracy</p> <p>Remote Programming Output Level Resolution</p> <p>Flatness (total variation)</p> <p>Output Leveling Switching Time (to be within ± 1 dB of final level)</p>	<p>Add ± 0.75 dB to remote programming absolute level accuracy</p> <p>1 dB</p> <p>1.50 dB 2.00 dB 2.50 dB</p> <p><20 ms</p>	<p>Absolute level accuracy specifications include allowances for detector linearity, temperature, flatness, attenuator accuracy, and measurement uncertainty.</p> <p>0 dBm Range, +15°C to +35°C</p> <p>2.0 to 6.2 GHz 2.0 to 12.4 GHz 2.0 to 18.0 GHz</p>
<p>REMOTE OPERATION Frequency</p> <p>Output Level RF Output ALC</p> <p>Interface Function Codes</p>	<p>Programmable over the full range with the same resolution as manual mode.</p> <p>Programmable in 1 dB steps, +8 to -120 dBm, plus 5 dB of overrange Programmable to either ON or OFF. Programmable for internal, crystal diode, or power meter leveling.</p> <p>SH1, AH1, T6, TE0, L4, LE0, SR1, RL2, PP2, DC1, DT0, and C0.</p>	
<p>GENERAL Operating Temperature</p> <p>Power</p> <p>E.M.I.</p> <p>Net Weight</p> <p>Dimensions: Height Width Depth</p> <p>Accessories</p>	<p>0 to +55°C (see note at the beginning of this table).</p> <p>100, 120, 220, or 240V, +5%, -10%, 48-66 Hz, 300 VA maximum.</p> <p>Conducted and radiated interference is within the requirements of MIL-I-6181D.</p> <p>27.2 kg (60 lbs)</p> <p>146 mm (5.7 in.) 425 mm (16.8 in.) 620 mm (24.4 in.)</p> <p>For ordering cabinet accessories, module sizes are 5-1/4H, 1 MW, 23D, System II</p> <p>Power Cord, Operating and Service Manual, and four extender boards.</p>	

Table 1-2. Supplemental Characteristics

Supplemental characteristics are intended to provide information useful in applying the instrument by giving typical, but non-warranted, performance parameters.

FREQUENCY

Internal Reference: The internal reference oscillator accuracy is a function of time base calibration \pm aging rate, \pm temperature effects, and \pm line voltage effects. Typical temperature and line voltage effects are $<1 \times 10^{-7}/^{\circ}\text{C}$ and $<5 \times 10^{-10}/+5\%$ to -10% line voltage change. Reference oscillator is kept at operating temperature in STANDBY mode with the instrument connected to mains power. The aging rate is $<5 \times 10^{-10}/\text{day}$ after a 24 hour warmup.

External Reference Input: 5 or 10 MHz at a level of 0.1 to 1 Vrms into 50 Ω . Stability and spectral purity of the microwave output will be partially determined by characteristics of the external reference frequency.

Reference Outputs: 10 MHz at a level of 0.2 Vrms into 50 Ω . 100 MHz at a level of 0.2 Vrms into 50 Ω .

SPECTRAL PURITY

Residual FM: 80 Hz rms in a 50 Hz—15 kHz Post-detection bandwidth from 2—6.2 GHz. Residual FM doubles in the 6.2—12.4 GHz range and triples in the 12.4—18.0 GHz range.

RF OUTPUT

For power settings $>+3$ dBm, changes in frequency from <10 GHz to >16 GHz may require a settling period for the power to stabilize at the set level. Spurious output oscillations may occur for settings above $+8$ dBm.

External leveling device characteristics will determine output flatness, absolute level accuracy, and switching time in external leveling modes.

Maximum Reverse Power: 1W RF input; 1 MHz—20 GHz, 0 Vdc.

Impedance: 50 Ω .

Source SWR: $\leq 2.0:1$.

Table 1-3. Recommended Test Equipment (1 of 3)

Instrument	Critical Specifications	Recommended Model	Use*
AC Voltmeter	Range: 1 mV to 10V Accuracy: $\pm 1.5\%$ of full scale $\pm 1.5\%$ of reading Frequency Response: 3 kHz to 3 MHz	HP 400E	A
Attenuator, Fixed 3 dB	Range: dc to 1 GHz Accuracy: ± 0.5 dB SWR: < 1.3	HP 8491A Option 003	A
Attenuator, Fixed 20 dB	Range: dc to 18 GHz Accuracy: ± 1.0 dB SWR: < 1.6	HP 8491B Option 020	C, P
Cable, Special Interconnect	See YTO Loop Phase Detector Adjustments in Section V	Locally Fabricated	A
Controller, HP-IB	HP-IB compatibility as defined by IEEE Standard 488-1978 and the identical ANSI Standard MC1.1: SH1, AH1, T2, TE0, L2, LE0, SR0, RL0, PP0, DC0, DT0, and C1, 2, 3, 4, 5.	HP 85B/82937A or 9826A Option 011 or 9836A with BASIC 2.0 Operating System	C, A, T, P
Crystal Detector	Frequency Range: 2 to 18 GHz Frequency Response: ± 1.5 dB	HP 8470B Option 012	P, A
Current Probe	Frequency Range: 2 to 35 MHz	HP 1110B	A
Digital Voltmeter (DVM)	Range: -60 V to $+40$ V dc Resolution: 100μ V on 1V dc range	HP 3456A or HP 3455A	A, T
Foam Pads (2 required)	43×58 cm (17×23 in.), 5 cm (2 in.) thick		P
Frequency Counter	Range: 2 to 18 GHz Resolution: 1 kHz 10 MHz Frequency Standard Output: ≥ 0.1 Vrms	HP 5343A	P, A, T
Frequency Standard	Long Term Stability: Better than 10^{-10} /day	HP 5065A	P, A
High Impedance Probe	Frequency: 400 MHz Output Impedance: 50Ω (compatible with Spectrum Analyzer).	HP 1121A	T
Local Oscillator	Range: 2 to 18 GHz Level: $+7$ dBm Single Sideband Phase Noise and Spurious Signals: Same as HP 8340A	HP 8340A	P, A
Logic State Analyzer	8 Bit Display, Triggerable	HP 1630A	T

Table 1-3. Recommended Test Equipment (2 of 3)

Instrument	Critical Specifications	Recommended Model	Use*
Logic Pulser	TTL compatible	HP 546A	T
Mixer	Response: 2 to 18 GHz VSWR, LO: $\leq 2.5:1$ VSWR, RF: $\leq 4.0:1$	RHG DMS1-18 ¹	P, A
Oscilloscope	Bandwidth: 50 MHz Vertical Sensitivity: 50 mV/div Vertical Input: 50 Ω ac or dc coupled External Trigger Capability	HP 1980B	P, A, T
Power Meter	Frequency: 2 to 18 GHz Range: +17 to -25 dBm	HP 436A	P, A, T
Power Sensor	Frequency: 2 to 18 GHz Input Impedance: 50 Ω SWR: < 1.28 Range: +17 to -25 dBm Must be compatible with power meter	HP 8481A	P, A, T
Power Source, Variable Frequency AC	Range: 110 to 120 Vac Frequency: 52 to 58 Hz Accuracy ± 2 Hz	California Instruments 501TC/800T ²	P
Power Supply	0 to 40 Vdc	HP 6200B	A, T
Amplifier, 20 dB	Frequency: 100 kHz Gain: 20 ± 5 dB Output Power: > -10 dBm Noise Figure: < 5 dBm Impedance: 50 Ω	HP 8447A	P
Amplifier, 40 dB	Frequency: 100 kHz Gain: 45 ± 5 dB Output Power: > -10 dBm Impedance: 50 Ω	HP 8447D and HP 8447E or HP 8447F	P
Probe, 10:1	Must be compatible with the oscilloscope.	HP 10017A	A
Signal Generator	Output Level: -5 to -20 dBm at 240 MHz	HP 8640B or HP 8340A	A
Spectrum Analyzer (with Tracking Generator)	Frequency Range: 20 Hz to 300 kHz Frequency Span/Division: 20 Hz minimum Noise Sidebands: > 90 dB below CW signal, 3 kHz offset, 100 Hz IF bandwidth Input Level Range: -10 to -60 dBm Log Reference Control: 70 dB dynamic range in 10 dB steps Accuracy: ± 0.2 dB	HP 8556A/8552B/141T	A

Table 1-3. Recommended Test Equipment (3 of 3)

Instrument	Critical Specifications	Recommended Model	Use*
Spectrum Analyzer	Frequency Range: 5 Hz to 50 kHz Resolution Bandwidth: 1 Hz minimum Frequency Span/Division: 5 Hz to 500 Hz Amplitude Range: 0 to -70 dBm	HP 3580A	P, T
Spectrum Analyzer	Frequency Range: 100 kHz to 22 GHz Frequency Span/Division: 2 kHz minimum Amplitude Range: +10 to -90 dBm Noise Sideband: > 75 dB down 30 kHz from signal at 1 kHz resolution bandwidth Resolution Bandwidth: 30 Hz to 300 kHz	HP 8566B	P, A
Sweep Oscillator	Center Frequency: 150 to 200 MHz Center Frequency Resolution: 0.1 MHz Sweep Range: 10 and 200 MHz	HP 86222B/8620C or HP 8340A	A
Termination	50Ω BNC	HP 11593A	A
Termination	600Ω BNC Feedthrough	HP 11095A	P, A
Test Coupler Adapter	See YTM Adjustments in Section V	Locally fabricated	A
Test Oscillator	Level: 0 to 3V into 50Ω or 300Ω Range: 60 Hz to 10 kHz	HP 8116A	A, T
<p>* C = Operator's Check, P = Performance Tests, A = Adjustments, T = Troubleshooting</p> <p>¹ RHG Electronics Laboratory, Inc., 161 East Industry Court, Deer Park, NY 11729, Tel. (516) 242-1100, TWX 510-227-6083.</p> <p>² California Instruments, 5150 Convoy Street, San Diego, CA 92111, Tel. (714) 279-8620.</p>			

SECTION II INSTALLATION

2-1. INTRODUCTION

This section provides the information needed to install the CW Generator. Included is information pertinent to initial inspection, power requirements, line voltage selection, power cables, interconnection, environment, instrument mounting, storage and shipment.

2-2. INITIAL INSPECTION

WARNING

To avoid hazardous electrical shock, do not perform electrical tests when there are signs of shipping damage to any portion of the outer enclosure (covers, panels, meters).

Inspect the shipping container for damage. If the shipping container or cushioning material is damaged, it should be kept until the contents of the shipment have been checked for completeness and the instrument has been checked mechanically and electrically. The contents of the shipment should be as shown in Figure 1-1. Procedures for checking electrical performance are given in Section IV. If the contents are incomplete, if there is mechanical damage or defect, or if the instrument does not pass the electrical performance test, notify the nearest Hewlett-Packard office. If the shipping container is damaged or the cushioning material shows signs of stress, notify the carrier as well as the Hewlett-Packard office. Keep the shipping materials for the carrier's inspection.

2-3. PREPARATION FOR USE

2-4. Power Requirements

The CW Generator requires a power source of 100, 120, 220 or 240 Vac, +5% to -10%, 48 to 66 Hz single phase. Power consumption is 300 VA maximum.

WARNINGS

This is a Safety Class I product (that is, provided with a protective earth terminal). An uninterruptible safety earth ground must be provided from the main

power source to the product input wiring terminals, power cord or supplied power cord set. Whenever it is likely that the protection has been impaired, the product must be made inoperative and be secured against any unintended operation.

If this instrument is to be energized via an external autotransformer, make sure the autotransformer's common terminal is connected to the neutral (that is, the grounded side of the mains supply).

2-5. Line Voltage and Fuse Selection

CAUTION

BEFORE PLUGGING THIS INSTRUMENT into the mains (line) voltage, be sure the correct voltage and fuses have been selected.

Verify that the line voltage selection cards and the fuses are matched to the power source. Refer to Figure 2-1, Line Voltage and Fuse Selection.

Fuses may be ordered under HP part numbers 2110-0003, 3.0A (250V) for 100/120 Vac operation and 2110-0043, 1.5A (250V) for 220/240 Vac operation.

2-6. Power Cables

WARNING

BEFORE CONNECTING THIS INSTRUMENT, the protective earth terminal of this instrument must be connected to the protective conductor of the (mains) power cables. The mains plug shall only be inserted in socket outlets provided with a protective earth contact. The protective action must not be negated by the use of an extension cord (power cable) without a protective conductor (grounding).

This instrument is equipped with a three-wire power cable. When connected to an appropriate ac power receptacle, this cable grounds the instrument

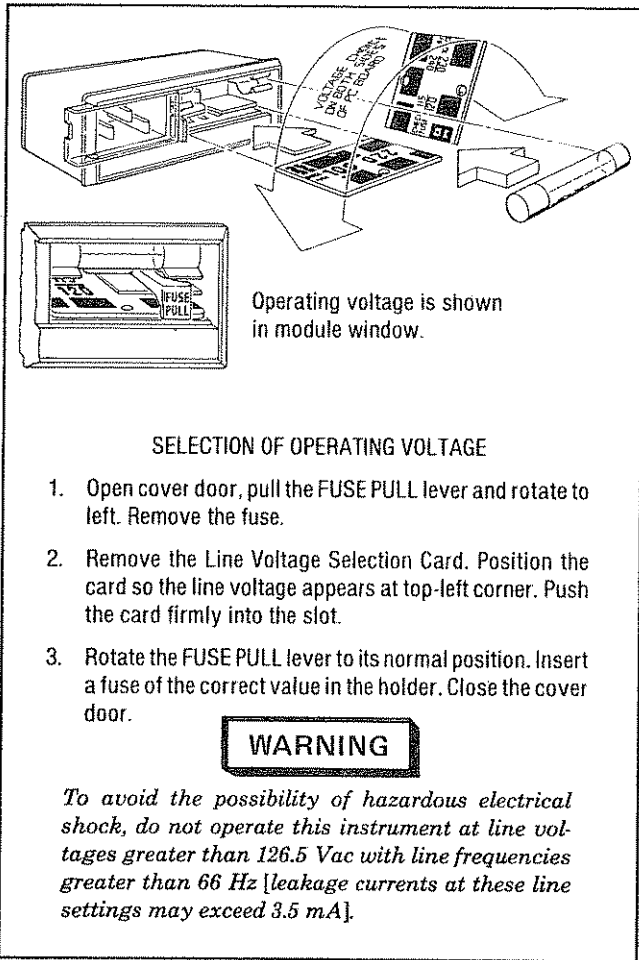

Figure 2-1. Line Voltage and Fuse Selection

Power Cables (cont'd)

cabinet. The power cable plug shipped with each instrument depends on the country of destination. Refer to Figure 2-2 for the part numbers of power cables available.

2-7. HP-IB Address Selection

In the CW Generator, the HP-IB talk and listen addresses and the parallel poll sense and response line can be selected by internal switches. Refer to Table 2-1 for a listing of talk and listen addresses. The address is factory set for a Talk address of "S" and a Listen address of "3". (In octal this is 23; in decimal this is 19.)

To change the HP-IB address or to select a different parallel poll response, proceed as follows:

WARNINGS

Internal switch settings should be changed only by service trained persons who are aware of the potential shock hazard of working on an instrument with protective covers removed.

To avoid hazardous electrical shock, the line (mains) power cable should be disconnected before attempting to change any internal switch settings.

<p>220/240V OPERATION</p>  <p>PLUG*: SEV 1011.1959-24507 TYPE 12 CABLE*: HP 8120-2104</p>	<p>220/240V OPERATION</p>  <p>PLUG*: NZSS 198/AS C112 CABLE*: HP 8120-1369</p>	<p>100/120V OPERATION</p>  <p>PLUG*: NEMA 5-15P CABLE*: 8120-1378</p>	<p>220/240V OPERATION</p>  <p>PLUG*: NEMA 6-15P CABLE*: HP 8120-0698</p>
<p>220/240V OPERATION</p>  <p>PLUG*: CEE7-VII CABLE*: HP 8120-1689</p>	<p>220/240V OPERATION</p>  <p>PLUG*: DHCK 107 CABLE*: HP 8120-2956</p>	<p>220/240V OPERATION</p>  <p>PLUG*: BS 1363A CABLE: HP 8120-1351</p>	
<p>*The number shown for the plug is the industry identifier for the plug only. The number shown for the cable is an HP part number for a complete cable including the plug.</p>			

Figure 2-2. Power Cable and Mains Plug Part Numbers

Table 2-1. Allowable HP-IB Address Codes

Address Switches (Octal)		Talk Address Character	Listen Address Character	Decimal Equivalent
S1	S2			
0	0	@	SP	0
0	1	A	!	1
0	2	B	"	2
0	3	C	#	3
0	4	D	\$	4
0	5	E	%	5
0	6	F	&	6
0	7	G	'	7
1	0	H	(8
1	1	I)	9
1	2	J	*	10
1	3	K	+	11
1	4	L	,	12
1	5	M	-	13
1	6	N	.	14
1	7	O	/	15
2	0	P	0	16
2	1	Q	1	17
2	2	R	2	18
2	3	S	3	19
2	4	T	4	20
2	5	U	5	21
2	6	V	6	22
2	7	W	7	23
3	0	X	8	24
3	1	Y	9	25
3	2	Z	:	26
3	3	[;	27
3	4	\	<	28
3	5]	=	29
3	6	^	>	30

HP-IB Address Selection (cont'd)

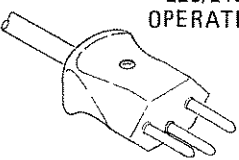
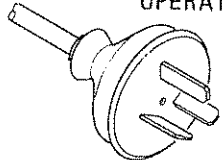
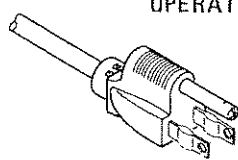
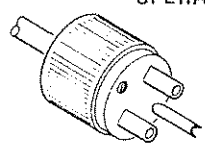
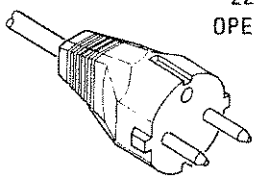
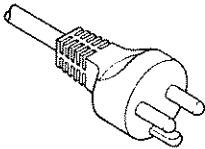
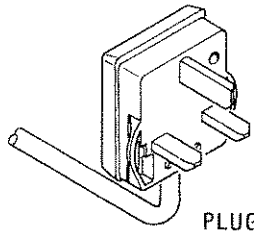
a. Set the LINE switch to STANDBY. Disconnect the line power cable.

b. Remove the CW Generator's top cover by removing the two plastic standoffs from the rear of the top cover and loosening the screw at the middle of the rear edge of the top cover. Then remove the A2 Assembly's protective cover. Refer to the Disassembly Procedures in Section VIII, Service Sheet A.

c. Select the new address as shown in Table 2-1. The switches are shown in Figure 2-3. The HP-IB ADDRESS SELECT switch settings (for S1 and S2) are in the octal code. For example, the factory selected addresses are set to 23 (decimal 19). Therefore, the listen address is '3' and the talk address is 'S'.

d. If the parallel poll sense or response switches are to be changed, remove any HP-IB cables or connectors from the HP-IB connector, and remove the HP-IB connector. Then remove the A2A9 Board Assembly.

e. The PARALLEL POLL SENSE switch (S4) is set to either the OFF, 0 (zero) or 1 (one) position. The zero position provides a false (+2.5 to 5 volts) output on the asserted HP-IB data line; the one position provides a true (0 to +0.4V) output on the asserted HP-IB data line.

f. The PPR (Parallel Poll Response) switch (S3) is set to select one of eight lines (one of 1 through 8 of the HP-IB data bus). The selected line passes the CW Generator's parallel poll response to the HP-IB controller.

g. Re-install the A2A9 Assembly and HP-IB connector.

h. Replace the A2 Assembly's internal cover, the instrument's top cover, and rear standoffs.

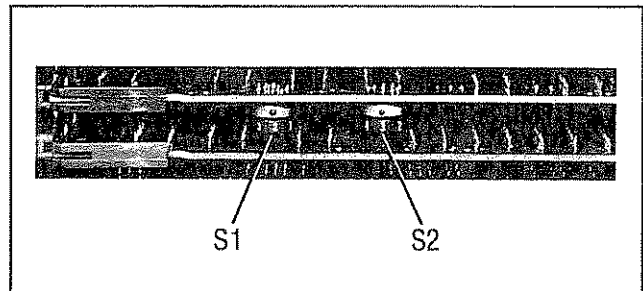

Figure 2-3. HP-IB Address Switches Shown as Set by the Factory

2-8. Interconnections

Interconnection data for the Hewlett-Packard Interface Bus is provided in Figure 2-4.

2-9. Mating Connectors

HP-IB Interface Connector. The HP-IB mating connector is shown in Figure 2-4. Note that the two securing screws are metric.

Coaxial Connectors. Coaxial mating connectors used with the CW Generator RF output should be 50Ω Type N male connectors.

2-10. Operating Environment

The operating environment should be within the following limitations:

Operating Environment (cont'd)

Temperature	0 to +55°C
Humidity	<95% relative
Altitude	<4570 metres (15,000 feet)

NOTE

Specifications for RF Output apply only between +15 and +35°C.

2-11. Bench Operation

The instrument cabinet has plastic feet and fold-away tilt stands for convenience in bench operation. (The plastic feet are shaped to ensure self-aligning of the instruments when stacked.) The tilt stands raise the front of the instrument for easier viewing of the front panel.

2-12. Rack Mounting**WARNING**

The CW Generator weighs 27.2 kg (60 lbs), therefore extreme care must be exercised when lifting to avoid personal injury. Use equipment slides when rack mounting the instrument.

Rack mounting information is provided with the rack mounting kits. If the kits were not ordered with the instrument as options, they may be ordered through the nearest Hewlett-Packard office. Refer to the paragraph entitled Mechanical Options in Section I.

2-13. STORAGE AND SHIPMENT**2-14. Environment**

The instrument should be stored in a clean, dry environment. The following environmental limitations apply to both storage and shipment:

Temperature	-55 to +75°C
Humidity	<95% relative
Altitude	15,300 metres (50,000 feet)

2-15. Packaging

Preparation for Packaging. Remove handles and/or rack mount flanges before packaging instrument for shipping.

Tagging for Service. If the instrument is being returned to Hewlett-Packard for service, please complete one of the blue repair tags located at the back of this manual and attach it to the instrument.

Original Packaging. Containers and materials identical to those used in factory packaging are available through Hewlett-Packard offices. Mark the container "FRAGILE" to assure careful handling. In any correspondence refer to the instrument by model number and full serial number.

Other Packaging. The following general instructions should be used for re-packaging with commercially available materials:

- a. Wrap the instrument in heavy paper or plastic. (If shipping to a Hewlett-Packard office or service center, complete one of the blue tags mentioned above and attach it to the instrument.)
- b. Use a strong shipping container. A double-wall carton made of 2.4 MPa (350 psi) test material is adequate.
- c. Use enough shock-absorbing material (75 to 100 mm layer; 3 to 4 inches) around all sides of the instrument to provide firm cushion and prevent movement in the container. Protect the front panel with cardboard.
- d. Seal the shipping container securely.
- e. Mark the shipping container "FRAGILE" to assure careful handling.

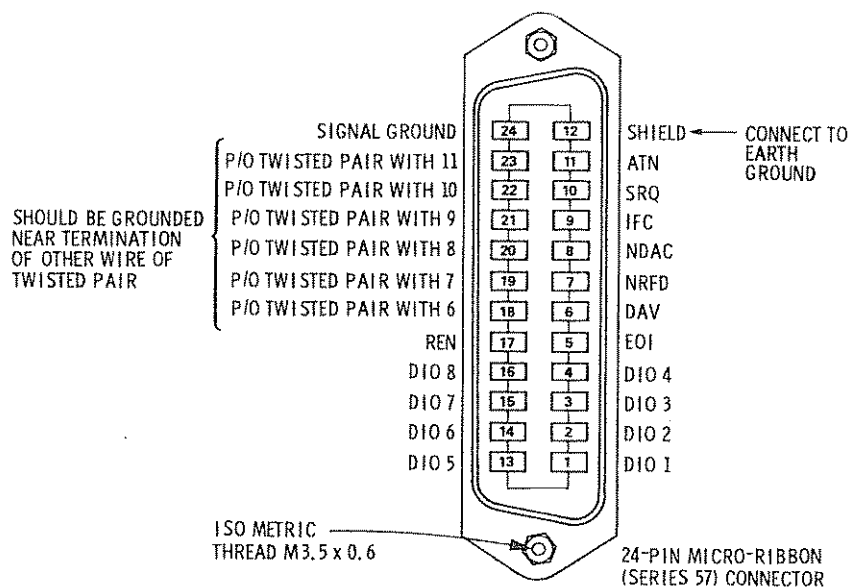

Logic Levels

The Hewlett-Packard Interface Bus Logic Levels are TTL compatible, i.e., the true (1) state is 0.0 Vdc to +0.4 Vdc and the false (0) state is +2.5 Vdc to +5.0 Vdc.

Programming and Output Data Format

Refer to Section III, Operation.

Mating Connector

HP 1251-0293; Amphenol 57-30240.

Mating Cables Available

HP 10833A, 1 metre (3.3 ft), HP 10833B, 2 metres (6.6 ft)
 HP 10833C 4 metres (13.2 ft), HP 10833D, 0.5 metres (1.6 ft)

Cabling Restrictions

1. A Hewlett-Packard Interface Bus system may contain no more than 2 metres (6 ft) of connecting cable per instrument.
2. The maximum accumulative length of connecting cable for any Hewlett-Packard Interface Bus system is 20.0 metres (65.6 ft).

Figure 2-4. Hewlett-Packard Interface Bus Connection



SECTION III OPERATION

3-1. INTRODUCTION

This section provides complete operating information for the CW Generator. Included are both simplified and detailed operating instructions, detailed descriptions of the front and rear panel, local and remote operator's checks, and operator's maintenance.

3-2. Panel Features

Front and rear panel features are described in detail in Figures 3-1 and 3-2.

3-3. Operating Characteristics

Table 3-1 briefly summarizes the major operating characteristics of the CW Generator. This table is not intended to be a complete listing of all operations and ranges, but gives a general idea of the instrument's capabilities. For more information on the CW Generator's capabilities, refer to Table 1-1, Specifications, and Table 1-2, Supplemental Characteristics. For information on HP-IB capabilities, refer to Table 3-3, Message Reference Table.

3-4. Local Operation

Information covering front panel operation of the CW Generator is given in the sections described below. To quickly learn the operation of the instrument, begin with Operating Characteristics and Simplified Operation. (Operator's Checks can also be used to gain familiarity with the instrument.) Once familiar with the general operation of the instrument, use the Detailed Operating Instructions as a reference for more complete operating information.

Turn-On Information. Instructions relating to the CW Generator turn-on procedure and frequency standard selection are presented to acquaint the user with the general operation of the instrument.

Simplified Operation. The instructions located on the inside of the fold provide a quick introduction to the operation of the CW Generator. In addition, an index to the Detailed Operating Instructions

is provided to direct the user to the more complete discussion of the topic of interest.

Detailed Operating Instructions. The Detailed Operating Instructions provide the complete operating reference for the CW Generator user. The instructions are organized alphabetically by subject. They are indexed by function in Table 3-2.

3-5. Remote (HP-IB) Operation

The CW Generator is capable of remote operation via the Hewlett-Packard Interface Bus (HP-IB).

HP-IB is Hewlett-Packard's implementation of the IEEE Standard 488, "IEEE Standard Digital Interface for Programmable Instrumentation", also described by the identical ANSI Standard MC1.1. For a more detailed information relating to programmable control of the CW Generator, refer to Remote (HP-IB) Operation in this section.

This section includes discussions on capabilities, addressing, input and output formats, the status byte and service request. In Table 3-4 is a complete summary of programming codes. In addition, programming examples are given in HP-IB Checks and in the Detailed Operating Instruction.

3-6. Operator's Checks

Operator's Checks are procedures designed to verify proper operation of the CW Generator's main functions. Two procedures are provided as described below.

Basic Functional Checks. This procedure requires only a 50 ohm load or attenuator to perform. For greater assurance, a microwave counter and a power meter can be used. This procedure assures that most front panel controlled functions are being properly executed by the CW Generator.

HP-IB Checks. This procedure assumes that front panel operation has been verified with the Basic Functional Checks. The procedure checks all of the applicable bus messages summarized in Table 3-3.

Table 3-1. Operating Characteristics

Frequency	Range: 2.0 to 18.0 GHz (Overrange to 18.599997 GHz) Resolution: 1 kHz 2.0 to 6.2 GHz 2 kHz 6.2 to 12.4 GHz 3 kHz 12.4 to 18.0 GHz
Output Level	Range: -120 to +8 dB in 10 dB steps Vernier: -10 to +3 dBm continuously variable
ALC	Internal, external crystal detector, or external power meter leveling.

Table 3-2. Index of Detailed Operating Instructions

3-14	ALC CONTROL	
	Local Procedure	3-4
	Internal Leveling	3-4
	External Crystal Detector Leveling	3-4
	External Power Meter Leveling	3-4
	Remote Procedure	3-5
	Comments	3-7
3-15	FREQUENCY CONTROL	3-8
	Local Procedure	3-8
	Remote Procedure	3-8
	Comments	3-10
3-16	LEVEL CONTROL	3-12
	Local Procedure	3-12
	Remote Procedure	3-12
	Comments	3-13
3-17	PEAK-NORM ADJUSTMENT	3-15
	Local Procedure	3-15
	Comments	3-15
3-18	RF ON-OFF SWITCH	3-16
	Local Procedure	3-16
	Remote Procedure	3-16
	Comments	3-16

3-7. Operator's Maintenance

WARNING

For continued protection against fire hazard, replace the line fuse with a 250V fuse of the same rating only. Do not use repaired fuses or short-circuited fuseholders.

Operator's maintenance consists of replacing defective primary fuses. This fuse is located in the line module assembly. Refer to Figure 2-1 for instructions on changing the fuse.

3-8. TURN-ON INSTRUCTIONS

WARNINGS

Before the instrument is switched on, all protective earth terminals, extension cords, autotransformers and devices connected to it should be connected to a protective earth grounded socket. Any interruption of the protective earth grounding will cause a potential shock hazard that could result in personal injury.

Only 250V normal blow fuses with the required rated current should be used. Do not use repaired fuses or short circuit fuseholders. To do so could cause a shock or fire hazard.

CAUTIONS

Before the instrument is switched on, it must be set to the voltage of the power source or damage to the instrument may result.

 *The CW Generator's RF OUTPUT is protected against reverse power applications up to 1W. However, for greatest protection of expensive internal components, be careful not to apply any reverse power to the RF OUTPUT.*

3-9. Turn-On

Turn-On Procedure. The CW Generator has a STANDBY state and an ON state. Whenever the power cable is plugged in, an oven is energized to keep the reference oscillator at a stable operating temperature. If the CW Generator is already plugged in, set the LINE switch to ON.

If the power cable is not plugged in, follow these instructions.

On the rear panel:

1. Check the line voltage switch for correct voltage selection.
2. Check that the fuse rating is appropriate for the line voltage used (see Figure 2-1).
3. Plug in the power cable.

On the front panel, set the LINE switch to ON.

NOTE

The OVEN status annunciator should light to indicate that the CW Generator requires warming up. The annunciator should turn off within fifteen minutes and the CW Generator should be ready for general use.

Turn-On Configuration. The CW Generator turns on at the same frequency as before it was switched to STANDBY or even completely off (that is, if line power was removed).

3-10. Frequency Standard Selection

A FREQ STANDARD INT/EXT switch and two connectors are located on the rear panel. A jumper normally connects the FREQ STANDARD INT connector (A3J9) to the FREQ STANDARD EXT connector (A3J10). The

Frequency Standard Selection (cont'd)

FREQ STANDARD EXT connector can accept a reference signal to be used instead of the CW Generator's internal reference oscillator.

When the FREQ STANDARD INT/EXT switch is in the INT position and the jumper is connected between A3J9 and A3J10, the internal reference oscillator is enabled.

When the FREQ STANDARD INT/EXT switch is in the EXT position and the jumper is disconnected from the FREQ STANDARD EXT connector, a frequency standard of 5 or 10 MHz at 0 dBm (nominal) can be connected.

NOTE

The INTERNAL REF OFF status annunciator on the front panel will light when an external reference is being used. Also, the NOT PHASE LOCKED status annunciator may light if the external reference is not of sufficient accuracy in frequency or has an insufficient power level. The external reference must be within ± 200 Hz of 10 MHz or ± 100 Hz of 5 MHz for reliable locking to occur. If the external reference level is not within the specified limits (0.1 to 1 Vrms into 50 ohms), its level may be sufficient to turn off the NOT PHASE LOCKED status annunciator. However, the phase noise of the CW Generator may be degraded.

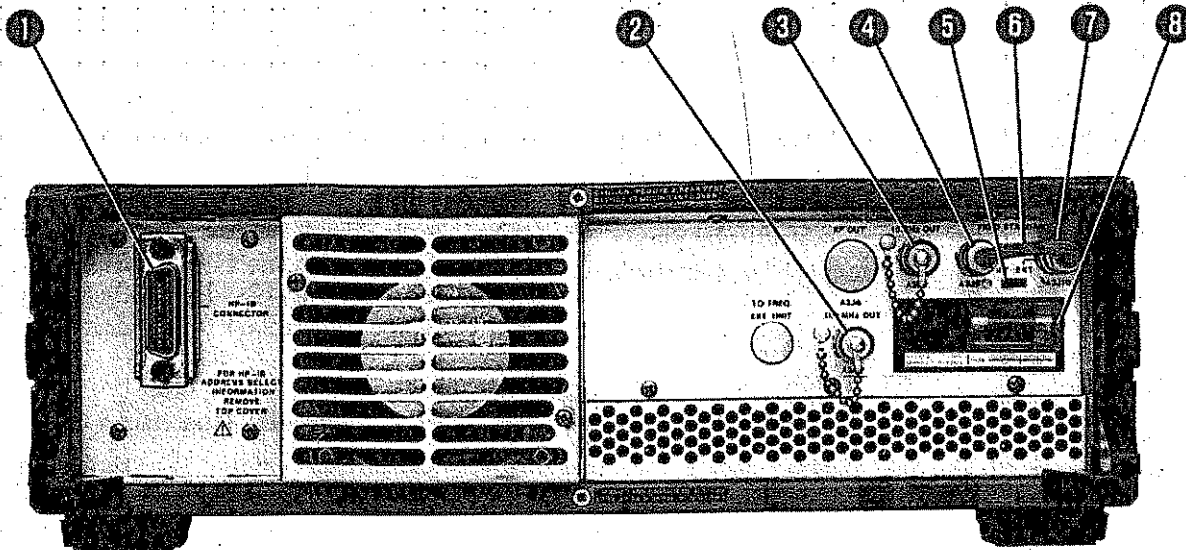

- ① **HP-IB CONNECTOR:** connects the CW Generator to the Hewlett-Packard Interface Bus for remote operation. When in remote operation, the ⑦ REMOTE annunciator illuminates.
- ② **100 MHz OUT (A3J7):** 0 dBm (nominal) into 50 ohms, can be used as an external timebase and for troubleshooting.
- ③ **10 MHz OUT (A3J8):** 0 dBm (nominal) into 50 ohms, can be used as an external timebase and for troubleshooting.
- ④ **FREQ STANDARD Output (A3J9):** 10.000 MHz into 50 ohms at +7 dBm (nominal) from the internal reference oscillator except when INT/EXT switch ⑤ is in the EXT position.
- ⑤ **FREQ STANDARD INT/EXT switch:** normally set to the INT position. Removes power from internal reference oscillator when in the EXT position.
- ⑥ **Jumper (A3W3):** normally connects the Internal Frequency Standard Output (A3J9) to the External Frequency Standard Input (A3J10).
- ⑦ **FREQ STANDARD Input (A3J10):** normally connected by A3W3 to A3J9. Also used to connect an external frequency standard of 5 or 10 MHz at 0 dBm to the CW Generator.
- ⑧ **Line Power Module:** permits operation from 100, 120, 220, or 240 Vac. The number visible in the window displays the nominal line (Mains) voltage for which the CW Generator is set (see Figure 2-1). The protective grounding conductor connects to the CW Generator through this module. The line power fuse (A3F1) is inside this module and is the only part to be changed by the operator.

Figure 3-2. Rear Panel Features

3-11. SIMPLIFIED OPERATION**3-12. Frequency**

Frequency is set using the FREQUENCY RESOLUTION keys and the TUNING knob. For example, to set the frequency to 15345.678 MHz:

Press PRESET (3 GHz). This is not always necessary, but it will set the right-hand six digits to 0, and may provide a convenient starting point.

Select the 100 MHz FREQUENCY RESOLUTION key and adjust the TUNING knob for a frequency of 15300.000 MHz.

Select the 1 MHz FREQUENCY RESOLUTION key and adjust the TUNING knob for a frequency of 15345.000 MHz. Select the 10 kHz FREQUENCY RESOLUTION key and adjust the TUNING knob for a frequency of 15345.670 MHz.

Select the 1 kHz FREQUENCY RESOLUTION key and adjust the TUNING knob for a frequency of 15345.678 MHz.

Press HOLD to disable the TUNING knob.

3-13. Output Level

The output level is set with the OUTPUT LEVEL RANGE and VERNIER controls.

First, adjust RANGE to step the output level up or down by increments of 10 dB. The selected range is shown in the RANGE dB display.

Adjust VERNIER between -10 and +3 dBm, as read on the meter, for the desired output level.

The output level is determined by adding the RANGE dB display to the LEVEL dBm meter reading.

3-14. ALC

ALC (automatic level control) has three modes of operation. They are:

INT (Internal leveling)

XTAL (External leveling using a crystal diode detector)

PWR MTR (External leveling using a power meter)

Internal leveling is selected for most applications. In this mode, an internal detector senses the level at the input of the 10 dB step attenuator, and the internal leveling circuitry keeps the output level constant. Loss of leveling is indicated by the LVL UNCAL annunciator.

For external leveling a crystal diode detector or power meter can be used. Operation is described further in the Detailed Operating Instructions.

3-15. ALC CONTROL

Description The Synthesized CW Generator has three modes of Automatic Level Control (ALC):
INT (Internal leveling)
XTAL (External leveling using a crystal diode detector)
PWR MTR (External leveling using a power meter)

For most applications internal ALC (INT) will be used. With internal ALC the output power remains flat over the entire 2 to 18 GHz frequency range.

External ALC is used when the power level at a remote point must be kept constant. External ALC reduces power variations due to external cables and connectors.

The ALC switch selects the leveling mode. Positive or negative detectors can be used to supply the external ALC input voltage. A calibration adjustment allows the externally leveled power to be adjusted to match the VERNIER setting over a limited output power range. The calibration adjustment does not affect internal leveling.

ALC mode and status are indicated by the ALC display. The display indicates which leveling source is selected and when the output is unleveled. The status of the ALC, whether leveled or unleveled, can also be determined remotely by reading the status byte.

Local Procedure

To use Internal Leveling:

Set the ALC selector to INT. The output level will be the sum of the range and VERNIER settings.

To use XTAL (External Crystal) Leveling:

1. Connect the crystal detector and the 10 dB coupler as shown in Figure 3-3.
2. Set the ALC selector to INT and adjust the VERNIER to read 0 dBm on the meter. This allows calibration of the meter to the leveled point.
3. Set the output level range to 0 dB and the ALC selector to XTAL.
4. Adjust the ALC CAL control to set the level read on the power meter to the nearest 10 dBm. If the ALC control does not have enough range for a low power level adjustment, step the RANGE down until the adjustment can be made.

This level should be within -3 dB and $+10$ dB of the desired level. This calibrates the meter to agree with the leveled power. If the detector is operating in the square law

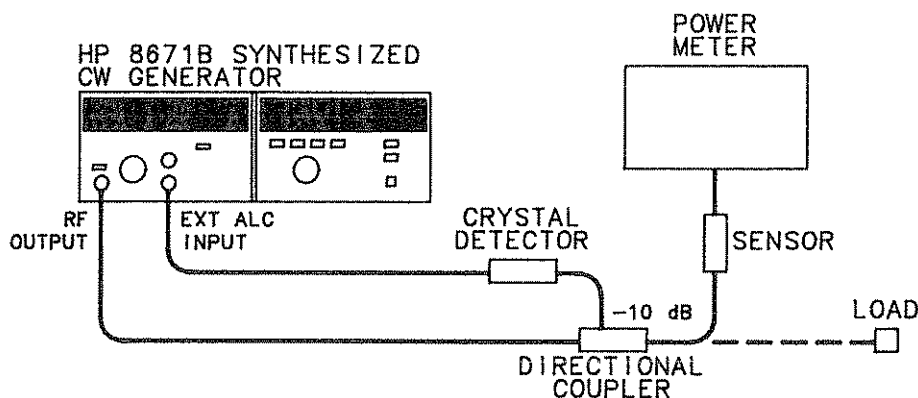

Figure 3-3. External Leveling with a Crystal Detector

ALC CONTROL (cont'd)**Local
Procedure
(cont'd)**

region, the VERNIER will now control the level over a continuous 13 dB range, and the CW Generator's meter reading will track with the power meter reading as the VERNIER control is varied through the -10 to $+3$ dBm range.

To use external power meter leveling:

1. Set the ALC selector to INT and adjust the VERNIER to read 0 dBm on the meter. This allows calibration of the CW Generator's meter to the leveled point.
2. Connect power meter to the point where leveling is to be used as shown in Figure 3-4. A directional coupler can be used to sample the power at the desired point. Set the output level to the desired power and select the range hold function on the power meter. This disables range changes and keeps the leveled power from oscillating.
3. Connect the recorder output of the power meter to the external ALC input connector. The recorder output is a voltage that is proportional to the measured power in watts. This voltage varies from 0 to 2 volts for each power meter range. Leveling as low as -60 dBm can be accomplished with a sensitive power sensor using this method.
4. Set the output level range to 0 dB and the ALC selector to PWR MTR.
5. Adjust the ALC CAL controls to set the level read on the power meter to the nearest 10 dBm. This level should be within -3 dB and $+10$ dB of the desired level (minus the coupling factor of the directional coupler). This calibrates the CW Generator's meter to agree with the leveled power. This power leveling method has a slow settling time but has the advantage of high sensitivity and temperature compensation.

If the ALC CAL control does not have enough range for a low power level adjustment, step the RANGE down until the adjustment can be made.

**Remote
Procedure**

The ALC program code controls the function of the RF output ON/OFF switch, the ALC selector and the $+10$ dB range of output power. The program string consists of the letter O followed by a single argument representing the desired combination of the control positions.

To set the CW Generator to the $+10$ dB range, you must first set it to 0 dB with the range command (code and argument) K0. Then you can set the $+10$ dB range with the appropriate ALC command.

The codes are summarized in the table under Program Codes.

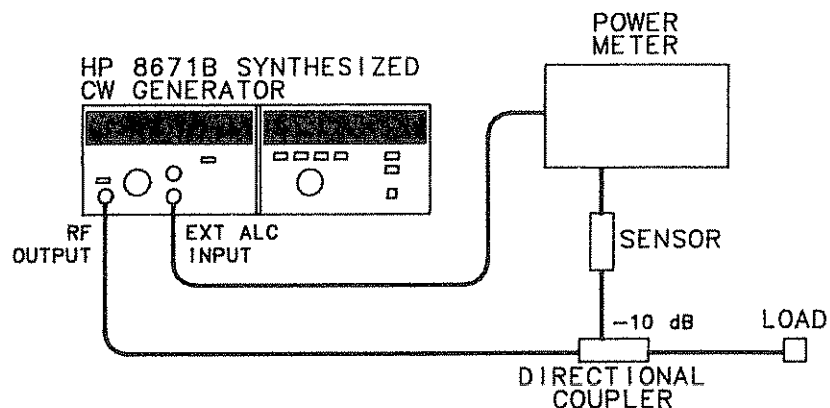

Figure 3-4. External Leveling with a Power Meter

ALC CONTROL (cont'd)

Example

To set internal ALC with an output level of +3 dBm:

Local

Set ALC selector to INT, RF output to ON, range to 0 dB and VERNIER for +3 dBm.

Or

Set ALC selector to INT, RF output to ON, range to +10 dB and VERNIER to -7 dBm.



K 0 L 0 0 1

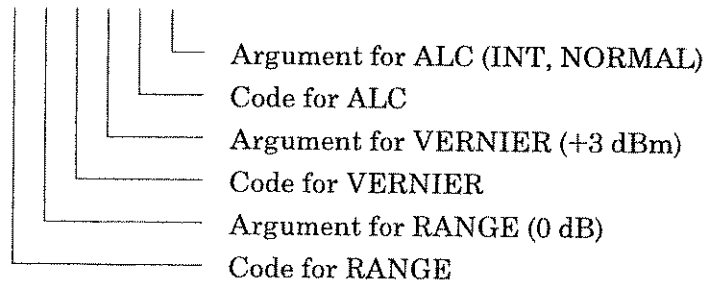

K 0 L : 0 3

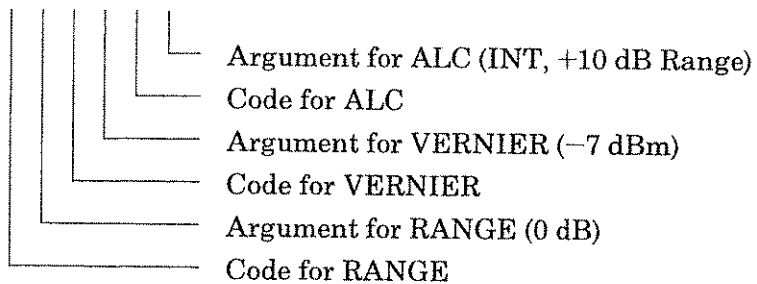

Program Codes HP-IB

Program Code	ALC Mode			Argument
	RF	RANGE	ALC	
O or _ (letter O, not zero)	OFF	NORM	INT	0
			XTAL	4
	ON	+10	PWR MTR	<
			INT	2
O or _ (letter O, not zero)	OFF	NORM	XTAL	6
			PWR MTR	>
	ON	+10	INT	1
			XTAL	5
ON	+10	PWR MTR	=	
		INT	3	
ON	+10	XTAL	7	
		PWR MTR	?	

ALC CONTROL (cont'd)**Comments**

Output level flatness is dependent on the ALC circuitry and the maximum available power. In order to have a leveled output it is necessary for the ALC circuitry to continuously control the output level. This can only occur if the selected output power is below the maximum power level available at each frequency. For leveled output power in the +10 dB range, it is necessary that the LVL UNCAL annunciator remain off.

External ALC leveling also requires that the CW Generator can produce enough power to overcome losses in the intervening circuitry. The LVL UNCAL annunciator must remain off to achieve leveling. The 0 dB range should be used when using external leveling. If any of the lower ranges are used, the CW Generator must produce a higher level to overcome the attenuation introduced by the range selected.

For output level settings above +8 dBm, spurious oscillations can occur, resulting in sidebands on the carrier at a level of -30 to -50 dBc. These oscillations occur only over small portions of the frequency range. They can usually be eliminated by performing a PEAK-NORM adjustment or by reducing the output level VERNIER setting 1 or 2 dB.

Typical output level switching times are detailed under Level Control. Enabling the RF output requires less than 30 milliseconds. Disabling the RF output can be accomplished in less than 5 milliseconds.

The state of the RF output (on or off) and the status of the +10 dB range (selected or not selected) can be obtained by reading the status byte. The status of the ALC circuitry (leveled or not leveled) can also be monitored by reading the status byte. Once the status byte indicates that the output is leveled, an application can continue without waiting the specified time for the output level to settle.

**Related
Sections**

Level Control
PEAK-NORM Adjustment

3.16 FREQUENCY CONTROL

Description The CW Generator uses a simple, convenient frequency tuning system.

All frequencies can be remotely programmed or entered manually by a tuning knob. The knob can be turned in either direction without encountering a mechanical stop. Also, the faster it is turned the greater the frequency change per revolution.

In addition, four degrees of coarse to fine tuning can be selected. Frequency resolution keys located above the tuning knob select 100 MHz, 1 MHz, 10 kHz or 1 kHz tuning increments. Due to frequency multiplication to generate frequencies above 6.2 GHz, the minimum tuning increment (resolution) is 2 kHz above 6.2 GHz and 3 kHz above 12.4 GHz.

Once a desired frequency has been set, pressing the HOLD key will disable the tuning control and prevent unintentional changes in the frequency. The preset key sets the output frequency to 3000.000 MHz for conveniently setting the least significant digits to zeroes.

When the CW Generator is turned off or the power cable is removed, the last frequency setting is stored in battery-powered memory. When the instrument is powered up, the frequency returns to the stored value. This feature maintains the frequency setting even after power failures or extended periods without power.

Local Procedure

To set the output frequency to any desired frequency:

1. Press PRESET (3 GHz). This is not always necessary, but it will set the right-hand six digits to 0, and may provide a convenient starting point.
2. Select the desired tuning increment (100 MHz, 1 MHz, 10 kHz, or 1 kHz) by pressing the appropriate FREQUENCY RESOLUTION key, and use the TUNING knob to set the frequency digits above the rightmost lighted segment in the frequency resolution display.
3. Once the desired frequency is set, press the HOLD key to disable the TUNING knob.

Remote Procedure

The CW Generator accepts any frequency within its range (2000.000 to 18599.997 MHz) to 8 significant digits. Above 6.2 GHz the frequency is randomly rounded up or down to be compatible with the 2 kHz or 3 kHz resolution at the programmed frequency.

The CW Generator ignores spaces, commas, decimal points, carriage returns and line feeds.

Within the CW Generator, frequency information is stored in two separate blocks of four digits each. The effects of programming codes on the two internal frequency data blocks are shown in Figure 3-5. One block contains the 10 GHz through 10 MHz frequency digits and the other contains the 1 MHz through 1 kHz digits. Programming within one block does not change the other blocks unless it is necessary to round off a frequency above 6.2 GHz. The programming codes indicate the most significant digit being programmed.

The output frequency does not change until the frequency execute command (Z1) is received by the CW Generator. This command must be sent sometime after the frequency data has been sent.

FREQUENCY CONTROL (cont'd)

Example To change frequency from 3000.231 MHz to 3450.001 MHz:

Local

1. Press the 100 MHz (leftmost) FREQUENCY RESOLUTION key. Adjust TUNING for a frequency of 3400.000 MHz.
2. Press the 1 MHz (next) FREQUENCY RESOLUTION key. Adjust TUNING for a frequency of 3450.000 MHz.
3. Press the 1 kHz (rightmost) FREQUENCY RESOLUTION key. Adjust TUNING for a frequency of 3450.001 MHz.

HP-IB Q 3450001 Z 1

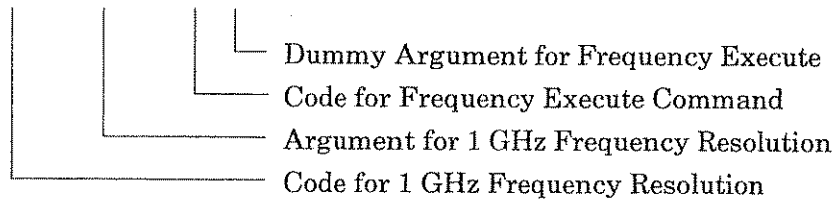

— or —

R 450001 Z 1

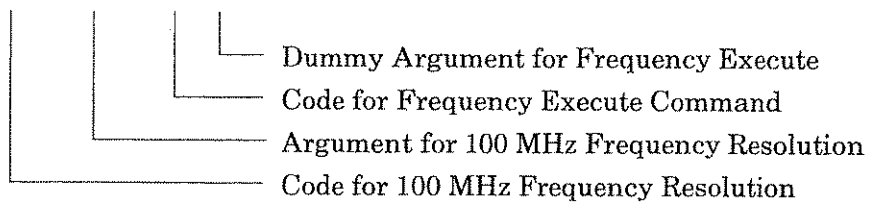

— or —

R 45 W 1 Z 1

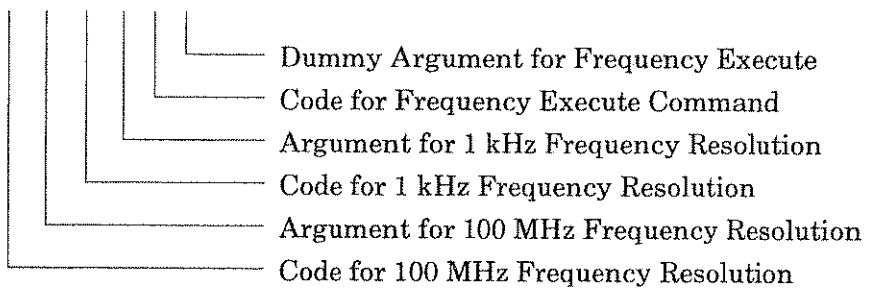

Program Codes



	PROGRAM CODES		ARGUMENTS
FREQUENCY	10 GHz	@ or P	0 THROUGH 9
	1 GHz	A or Q	
	100 MHz	B or R	
	10 MHz	C or S	
	1 MHz	D or T	
	100 kHz	E or U	
	10 kHz	F or V	
	1 kHz	G or W	
EXECUTE	J or Z		

FREQUENCY CONTROL (cont'd)

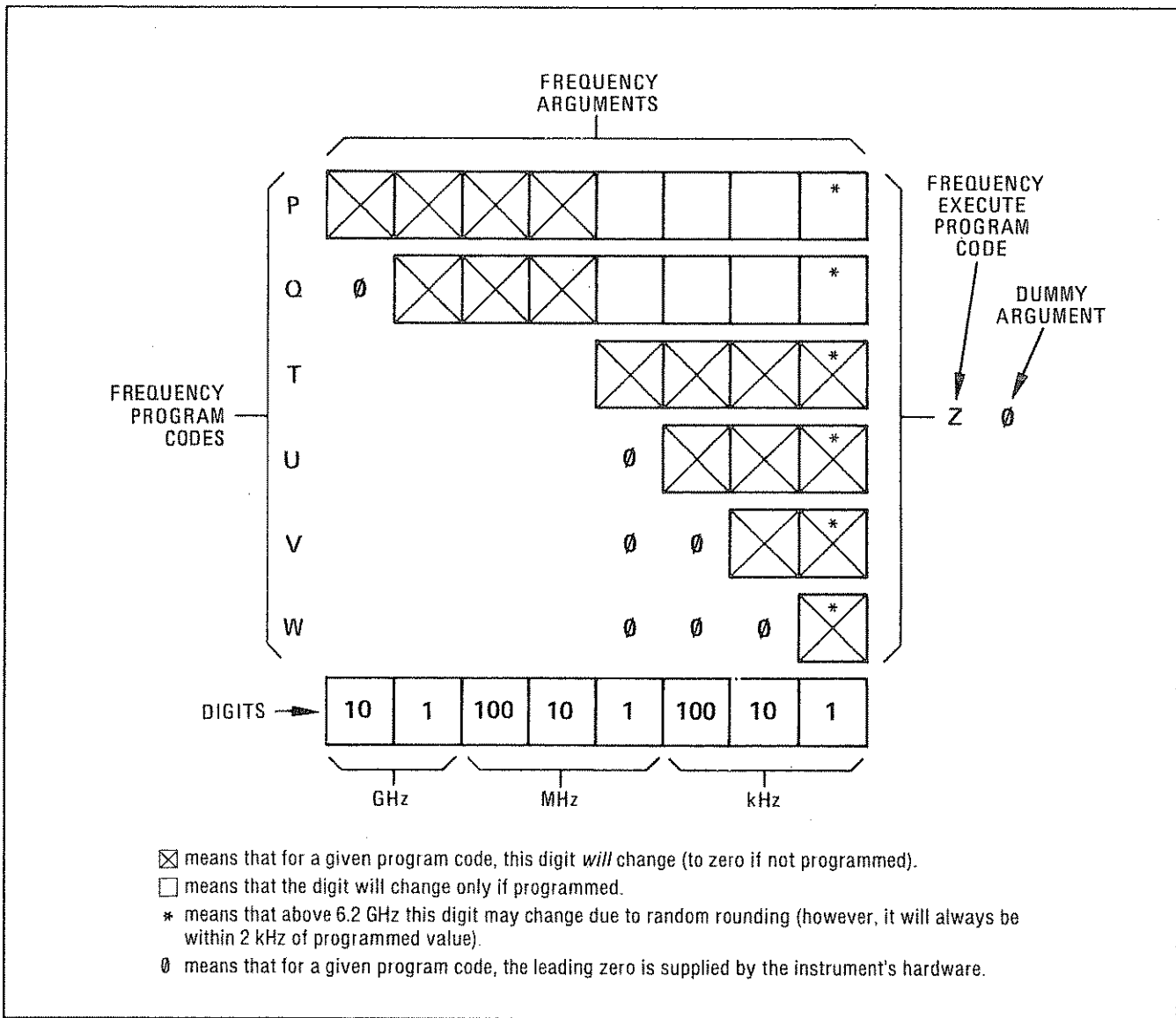

Figure 3-5. Frequency Programming Codes and Arguments

Comments

Due to the use of frequency multiplication to generate frequencies above 6.2 GHz, the frequency sometimes cannot be set precisely to a desired value. Frequencies between 2 and 6.2 GHz can be set to the nearest 1 kHz. All frequencies between 6.2 and 12.4 GHz can be set within 1 kHz of the desired value. All frequencies between 12.4 and 18 GHz can be set within 2 kHz of the desired frequency.

When the CW Generator is programmed to a frequency that is not evenly divisible, a random roundoff occurs. To prevent this, during remote programming one should perform a calculation to determine whether the frequency can be set exactly.

To determine whether a frequency can be set to a given value, divide the desired frequency (in kHz) by two if it is between 6.2 and 12.4 GHz, or by three if it is above 12.4 GHz. If the result is a whole number (with no remainder) the frequency can be set to the

FREQUENCY CONTROL (cont'd)

Comments (cont'd)

desired value. For example, 16 GHz divided by three (it is above 12.4 GHz) is 5333333.33 kHz, so this frequency cannot be set exactly. The nearest frequencies that can be set are 15.999999 GHz (5.333333×3) and 16.000002 GHz (5.333334×3).

The time it takes to switch from one frequency to the next depends on the largest frequency digit being changed. Generally, the smaller the digit being changed, the shorter the switching time. Typical switching times by largest digit being changed for frequencies between 2 and 6.2 GHz can be summarized as follows:

Largest Digit Changed	Time to be Within 1 kHz
100 MHz	10 ms
10 MHz	10 ms
1 MHz	10 ms
100 kHz	5 ms
10 kHz	3 ms
1 kHz	1.5 ms

For frequencies above 6.2 GHz, actual frequency digits being changed must be determined by dividing the output frequency by two (6.2 to 12.4 GHz) or three (12.4 to 18 GHz). The actual data transfer time is only a small portion of the frequency switching time and can be ignored.

For applications that require fast execution, the status byte can be checked until the frequency is phase locked. Once the status byte indicates that the CW Generator is phase locked, the application may continue with the assurance that the frequency is correct. Figure 3-6 shows the typical worst case lock and settling times.

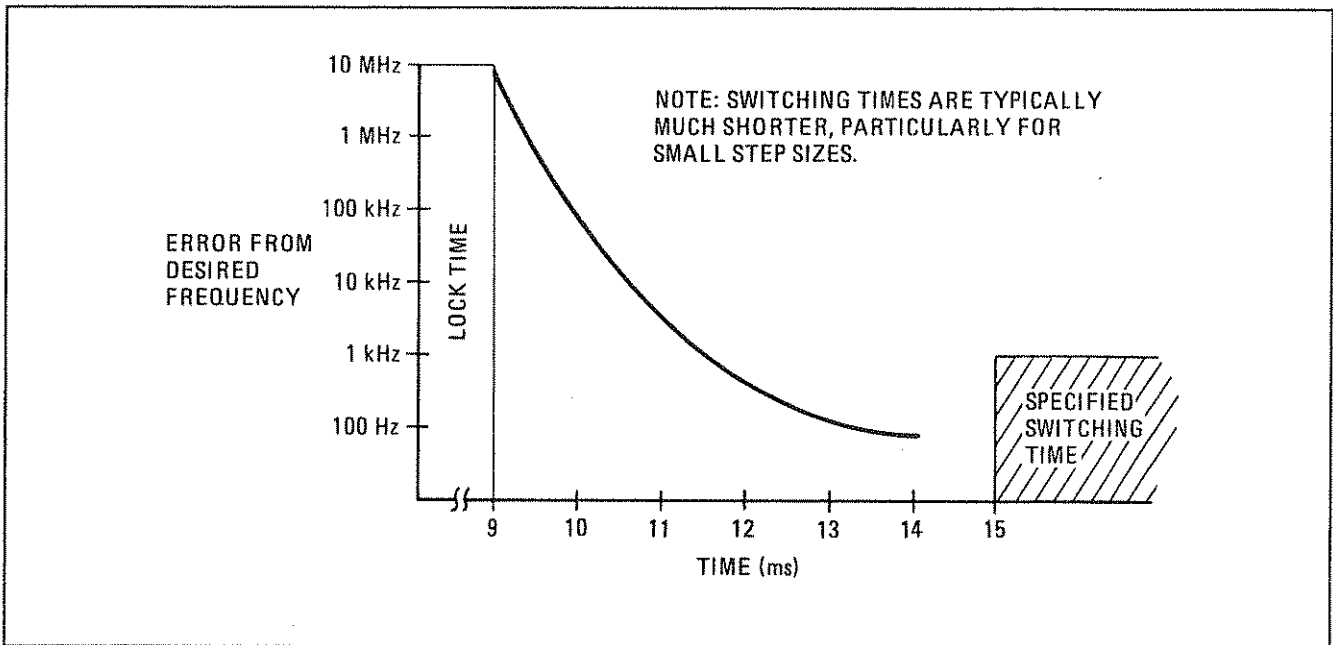

Figure 3-6. Frequency Switching Time Showing Worst Case

3-17. LEVEL CONTROL

Description The Synthesized CW Generator is calibrated over a wide range of output power levels from +8 dBm to -120 dBm. The output level is set with a RANGE selector and a VERNIER control. The output level is the sum of the settings of these two controls.

The RANGE selector varies the output level in 10 dB steps. The selected range (+10 dB to -110 dB) is digitally displayed in the RANGE display. This display indicates the selected range in both local and remote modes. Output level ranges of 0 dB to -110 dB are programmable with the range program code. The +10 dB range is selected using the ALC program code.

The VERNIER knob continuously varies the output level in the 0 dB range from -10 to +3 dBm. The VERNIER setting is indicated by the front panel meter.

In local mode the VERNIER can be varied continuously over the full 13 dB range. In remote mode the VERNIER can be programmed in fourteen 1 dB steps from -10 dBm to +3 dB. Because the VERNIER can be controlled over greater than 10 dB in both local and remote mode, it is possible to overlap range settings by 3 dB. This is useful in applications where the ability to vary the output power continuously about a given level is critical.

Local Procedure

To set the output level to any desired value:

1. Set the CW Generator ALC mode to internal (INT).
2. Set the OUTPUT LEVEL RANGE to within -3 to +10 dB of the desired output level. For example, for a -56 dBm output level choose the -50 dB range.
3. Adjust the OUTPUT LEVEL VERNIER setting until the sum of the range display and the meter is equal to the desired output level.

Some output levels may be set using either of two adjacent ranges. Either range may be used. For example, +3 dBm may be set with a 0 dB range and +3 dBm VERNIER setting or a +10 dB range and -7 dBm VERNIER setting.

Setting output levels above +8 dBm may cause an ALC unlevelled condition due to insufficient power available. The meter will indicate the actual power available when the unlevelled condition occurs.

Remote Procedure

The 0 dB to -110 dB ranges and the VERNIER setting are programmed with the output level program codes. The VERNIER setting is programmed in 1 dB steps from -10 dBm to +3 dBm. The range is programmed in 10 dB steps from 0 dB to -110 dB. The +10 dB range is programmed by setting RANGE to 0 dBm and ALC to +10 dB.

When switching from local to remote mode, the VERNIER is reset to -10 dB and the range remains unchanged.

Example

To set the output level to +3 dBm:

Local

Set RANGE to 0 dB and VERNIER to +3 dBm.

Or

Set RANGE +10 dB and VERNIER to -7 dBm.

LEVEL CONTROL (cont'd)

Example
(cont'd)



K 0 L 0

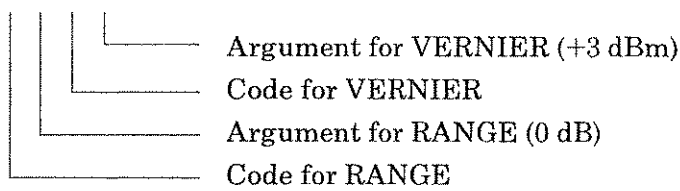

K 0 L : 0 3

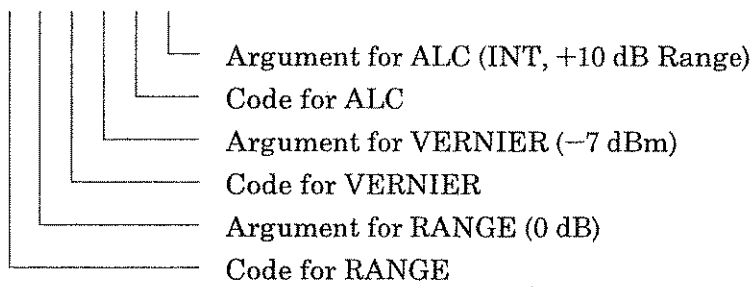

Program Codes



	Program Codes	Arguments
OUTPUT LEVEL RANGE	K	0 dBm 0
		-10 1
		-20 2
		-30 3
		-40 4
		-50 5
		-60 6
		-70 7
		-80 8
		-90 9
		-100 :
		-110 ;

	Program Codes	Arguments
OUTPUT LEVEL VERNIER	L	+3 dB 0
		+2 1
		+1 2
		0 3
		-1 4
		-2 5
		-3 6
		-4 7
		-5 8
		-6 9
		-7 :
		-8 ;
-9 <		
-10 =		

Comments

Output level flatness is dependent on the ALC circuitry and the maximum available power. In order to have a leveled output it is necessary for the ALC circuitry to continuously control the output level. This can only occur if the selected output power is below the maximum power level available at each frequency. For leveled output power in the +10 dB range, it is necessary that the LVL UNCAL annunciator remain off. If it lights, adjust the PEAK-NORM control, or reduce the VERNIER setting.

For output level settings above +8 dBm, spurious oscillations can occur, resulting in sidebands on the carrier at a level of -30 to -50 dBc. These oscillations occur only over small portions of the frequency range.

LEVEL CONTROL (cont'd)

Comments (cont'd) They can usually be eliminated by performing a PEAK-NORM adjustment or by reducing the OUTPUT LEVEL VERNIER setting 1 or 2 dB.

External ALC leveling also requires that the CW Generator can produce enough power to overcome losses in the intervening circuitry. The LVL UNCAL annunciator must remain off to achieve leveling. If it lights adjust the PEAK-NORM control, or decrease the VERNIER setting.

Typical output level range change execution time for a 10 dB step is less than 20 milliseconds. An output level VERNIER change of 1 dB will take less than 10 milliseconds. These times are typical for remote programming. The actual data transfer time is a very small part of the execution time and may be ignored for most controllers.

The RF output changing from enabled to disabled takes less than 5 milliseconds. To enable the RF output from a disabled state requires less than 30 milliseconds.

The state of the RF output (on or off) and the +10 dB range (selected or not selected) can be obtained by reading the status byte. These two functions are programmed along with the ALC mode. For more information see ALC Control.

Related Sections

ALC Control
PEAK-NORM Adjustment

3-18. PEAK-NORM ADJUSTMENT

Description	The PEAK-NORM control adjusts an internal filter for maximum power output at a single frequency. This filter is adjusted for best over-all performance with the control in the detent position (NORM), but can be adjusted for maximum power (and reduced harmonics and sub-harmonics) at any one frequency. This adjustment will result in lower maximum power at most other frequencies, and therefore should be left in the NORM position except when maximum power is needed. It should only be required at power levels above +8 dBm.
Local Procedure	To maximize the output power at a set frequency: Adjust the PEAK-NORM adjustment until the LVL UNCAL annunciator turns off, or for maximum meter reading with the VERNIER fully clockwise.
Remote Procedure	This adjustment cannot be remotely programmed.
Example	To peak an output level of +10 dBm at 8 GHz due to a LVL UNCAL indication: <ol style="list-style-type: none">1. Adjust the PEAK-NORM adjustment until the LVL UNCAL annunciator turns off, or for maximum meter reading with the VERNIER fully clockwise.2. Return the PEAK-NORM adjustment to NORM (detented) position before resuming normal instrument operation. The +8 dBm output power level is affected by this adjustment and is only specified with the PEAK-NORM adjustment set to NORM.
Comments	For output level settings above +8 dBm, spurious oscillations can occur, resulting in sidebands on the carrier at a level of -30 to -50 dBc. These oscillations occur only over small portions of the frequency range. They can usually be eliminated by performing a PEAK-NORM adjustment or by reducing the output level VERNIER setting 1 or 2 dB. The PEAK-NORM adjustment must be in the NORM (detented) position to guarantee the specified +8 dBm level over the entire frequency range.

3-19. RF ON/OFF SWITCH

Description The RF ON/OFF switch provides a convenient way of turning off the output signal. This is useful when calibrating detectors, zeroing power meters, or making noise measurements with no signal applied. With the switch in the off position the internal 2 to 6.2 GHz oscillator is turned off to prevent any signal leakage to the RF output connector.

The RF annunciator indicates the position of the RF ON/OFF switch in local mode and the programmed state when in remote mode. With the internal 2 to 6.2 GHz oscillator turned off, the CW Generator is no longer phase locked or leveled so the LVL UNCAL and NOT PHASE LOCKED annunciators are lighted.

**Local
Procedure**

To disable the RF output:

Set the RF ON/OFF switch to OFF. Note that the OFF, LVL UNCAL and NOT PHASE LOCKED annunciators should be lighted.

To enable the RF output:

Set the RF ON/OFF switch to ON. The LVL UNCAL and NOT PHASE LOCKED annunciators should extinguish and the ON annunciator should light.

**Remote
Procedure**

See ALC Control for a description of how to program the RF ON/OFF switch function.

**Program
Codes**

See ALC Control



Comments

The status of the RF output (on or off) can be determined by reading the status byte. A service request is not generated for LVL UNCAL or NOT PHASE LOCKED when the RF output is set to OFF.

The RF output off-to-on transition typically requires less than 30 milliseconds when remotely programmed. The on-to-off transition typically requires less than 5 milliseconds.

3-20. REMOTE (HP-IB) OPERATION

The CW Generator can be operated through the Hewlett-Packard Interface Bus (HP-IB). HP-IB compatibility, programming and data formats are described in the following paragraphs.

All front panel functions except that of the ALCAL control, PEAK-NORM control, and LINE switch are programmable via HP-IB.

A quick test of the CW Generator's HP-IB interface is described in this section under HP-IB Checks. These checks verify that the CW Generator can respond to or send each of the applicable bus messages described in Table 3-3.

3-21. HP-IB Compatibility

The CW Generator's programming capability is described by the twelve HP-IB messages listed in Table 3-3. The CW Generator's compatibility with HP-IB is further defined by the following list of interface functions: SH1, AH1, T6, TE0, L4, LE0, SR1, RL2, PP2, DC1, DT0, and C0. A more detailed explanation of these compatibility codes can be found in IEEE Standard 488-1978 and the identical ANSI Standard MC1.1.

3-22. Remote Mode

Remote Capability. The CW Generator communicates on the bus in both remote and local modes. In remote, the CW Generator's front panel controls are disabled except for the LINE switch. However, front panel displays remain active and valid. In remote, the CW Generator can be addressed to talk or listen. When addressed to listen, the CW Generator automatically stops talking and responds to the following messages: Data, Clear (SDC), Remote, Local, and Abort. When addressed to talk, the CW Generator automatically stops listening and sends one of the following messages: Data, Require Service, or Status Byte. Whether addressed or not, the CW Generator responds to the Clear (DCL), Clear Lockout/Set Local, and Abort messages. In addition, the CW Generator can issue the Require Service message and the Status Bit message.

Local-to-Remote Mode Changes. The CW Generator switches to remote operation upon receipt of the Remote message. The Remote message has two parts. They are:

- a. Remote enable bus control line (REN) set true.

- b. Device listen address received once (while REN is true).

When the CW Generator switches to remote, the REMOTE annunciator on the front panel turns on. With the exception of VERNIER, which will reset to -10 dBm, the CW Generator's control settings remain unchanged with the Local-to-Remote transition.

3-23. Local Mode

Local Capability. In local, the CW Generator's front panel controls are fully operational and the instrument will respond to a Remote message. The CW Generator can send a Require Service message, a Status Byte message, and a Status Bit message while in the Local mode.

Remote-to-Local Mode Changes. The CW Generator switches to local from remote whenever it receives a Local (GTL), Universal Unlisten address, Abort, or Clear Lockout/Set Local message. (The Clear Lockout/Set Local message sets the Remote Enable control line [REN] false.) The CW Generator can also be switched to local by turning the LINE switch to STANDBY, and then to ON.

With the Remote-to-Local transition, the frequency will remain the same. All other functions will return to the front panel settings. Power may go up, go down, or stay the same.

3-24. Addressing

When the Remote Enable line (REN) and the Attention control line (ATN) are true and the Interface Clear control line (IFC) is false, the CW Generator interprets the byte on the eight HP-IB data lines as an address or a command.

The CW Generator's Talk and Listen addresses can be set by switches located inside the instrument. The address selection procedure is described in Section II. Refer to Table 2-1 for a comprehensive listing of all valid HP-IB address codes.

3-25. Data Messages

The CW Generator communicates on the interface bus primarily with Data messages. Data messages consist of one or more bytes sent over the bus' data lines when the bus is in the data mode (attention control line [ATN] false). The CW Generator receives Data messages when addressed to listen, and sends the Status Byte message when addressed to talk. All instrument operations available in

Table 3-3. Message Reference Table (1 of 2)

HP-IB Message	Applicable	Response	Related Commands and Controls	Interface Functions*
Data	Yes	Frequency, Output level (RANGE and VERNIER), and ALC mode can be programmed. The CW Generator sends the status byte when addressed to talk.		AH1 SH1 T6, TE0 L4, LE0
Trigger	No	The CW Generator does not respond to the Group Execute Trigger (GET) bus command	GET	DT0
Clear	Yes	Sets frequency to 3000.000 MHz, RF output to off, ALC mode to Internal, and VERNIER to -10 dBm.	DCL SDC	DC1
Remote	Yes	Remote mode is enabled when the REN bus control line is true. However, remote mode is not entered until the first time the CW Generator is addressed to listen. The front panel REMOTE annunciator lights when the instrument is actually in the remote mode. The VERNIER is set to -10 dBm.	REN	RL1
Local	Yes	The CW Generator returns to local mode (front panel control). The CW Generator returns to the previous front panel settings, except for frequency.	GTL	RL2
Local Lockout	No	The CW Generator does not respond to the local lockout command.	LLO	RL2
Clear Lockout/ Set Local	Yes	The CW Generator returns to local (front panel control) when the REN bus control line goes false.	$\overline{\text{REN}}$	RL2
Pass Control/ Take Control	No	The CW Generator has no controller capability.		C0
Require Service	Yes	The CW Generator sets the SRQ bus control line true if one of the following conditions exists: frequency out of range, not phase locked with RF output on, or RF power level uncalibrated with RF power on.	SRQ	SR1
Status Byte	Yes	The CW Generator responds to a Serial Poll Enable (SPE) bus command by sending an 8-bit status byte when addressed to talk. If the instrument is holding the SRQ control line true (issuing the Require Service message), the RQS bit and the bit representing the condition causing the Require Service message to be issued will both be true.	SPE SPD	T5
Status Bit	Yes	The CW Generator responds to a Parallel Poll Enable (PPE) bus command by sending a status bit on a switch selected HP-IB data line.	PPE	PP2

Table 3-3. Message Reference Table (2 of 2)

HP-IB Message	Applicable	Response	Related Commands and Controls	Interface Functions*
Abort	Yes	The CW Generator stops talking and listening.	IFC	T6, TE0 L4, LE0
*Commands, Control lines, and Interface Functions are defined in IEEE Std 488-1978. Knowledge of these may not be necessary if your controller's manual describes programming in terms of the twelve HP-IB Messages shown in the left column.				
Complete HP-IB capability as defined in IEEE Std 488 and ANSI Std MC1.1 is: SH1, AH1, T6, TE0, L4, LE0, DT0, DC1, RL2, C0, SR1, and PP2.				

Data Messages (cont'd)

local mode can be performed in remote mode via Data messages except changing the ALC CAL and PEAK-NORM controls and the LINE switch setting.

3-26. Receiving Data Messages

The CW Generator responds to Data messages when it is enabled to remote (REN control line true) and addressed to listen. The instrument remains addressed to listen until it receives an Abort message or until its talk address or a universal unlisten command is sent by the controller.

A data message is a string of alternate codes and arguments, where a code is an ASCII character representing a function, such as frequency, RF output level, or ALC mode, and an argument is an ASCII digit representing a selection of the function. Each code and its argument make a command.

A complete summary of programming formats, codes and arguments is given in Table 3-4. In addition, programming examples are given in HP-IB Checks, and in the Detailed Operating Instructions.

The Complete Data Message. The following program string is a complete data message. It lists the commands in the order that the CW Generator decodes them, along with arguments that will be explained.

“P1Q2R3S4T5U6V7W8Z1K9L7M0N7O1”

The commands preceding Z1 program a frequency of 12345.678 MHz. Z1 is a frequency execute command which is required to execute a string of frequency commands. K9 and L7 program output RANGE and VERNIER to -90 dB and -4 dBm respectively. M0 and N7 are used to program AM and FM in the HP 8672A (a similar synthesized signal generator with AM and FM capabilities) and are used as dummy commands to make program strings compatible with the HP 8672A. The O1 command programs ALC to internal leveling.

The Abbreviated Data Message. If functions are programmed in the order listed, codes can be omitted from the string, except for the first code, and Z1, the frequency execute command, if programming frequency. Thus, the following string is equivalent to the one above.

“P12345678Z197071”

Furthermore, the string can begin with any code and end with any argument, and can be composed of combinations of this syntax. Thus, the following string will program the CW Generator to a frequency of 2345 MHz, with a VERNIER setting of 0 dBm, without changing the output level RANGE setting.

“Q2345Z1L3”

3-27. Receiving the Clear Message

The CW Generator responds to the Clear message by setting the frequency to 3 GHz, ALC to internal, and RF power off. The message can take two forms: Device Clear which the CW Generator re-

Receiving the Remote Message (cont'd)

sponds to only when addressed, and Selected Device Clear, which it responds to whether addressed or not. The Device Clear message does not affect addressing, while the Selected Device Clear message leaves the CW Generator addressed to listen.

3-28. Receiving the Trigger Message

The CW Generator does not respond to the Trigger message.

3-29. Receiving the Remote Message

The Remote message has two parts. First, the remote enable bus control line (REN) is held true; second, the device listen address is sent by the controller. These two actions combine to place the CW Generator in remote mode. Thus, the CW Generator is enabled to go into remote when the controller begins the Remote message, but it does not actually switch to remote until addressed to listen the first time. When actually in remote, the CW Generator's front panel REMOTE annunciator lights.

3-30. Receiving the Local Message

The Local message is the means by which the controller sends the Go To Local (GTL) bus command. The CW Generator returns to front panel control when it receives the Local message.

When the CW Generator goes to local mode, the front panel REMOTE annunciator turns off. However, even in local, the CW Generator sends the status byte when addressed to talk.

3-31. Receiving the Local Lockout Message

The CW Generator does not respond to the Local Lockout message.

**3-32. Receiving the Clear Lockout/
Set Local Message**

The Clear Lockout/Set Local message is the means by which the controller sets the Remote Enable (REN) bus control line false. The CW Generator returns to local mode (full front panel control) when it receives the Clear Lockout/Set Local message. When the CW Generator goes to local mode, the front panel REMOTE annunciator turns off.

3-33. Receiving the Pass Control Message

The CW Generator does not respond to the Pass

Control message because it does not have this controller capability.

3-34. Sending the Require Service Message

The CW Generator sends a Require Service message if one or more of the following conditions exists for more than 50 ms:

- 1) Frequency programmed out of range
- 2) Not phase locked with RF output on
- 3) RF power level uncalibrated (LVL UNCAL) with RF power on.

The CW Generator can send a Require Service message in either the local or remote mode, and whether or not addressed. It sends the message by setting the Service Request (SRQ) bus line true.

Once the CW Generator is addressed to talk, the RQS bit is latched, even though CW Generator's need for service may have changed.

3-35. Sending the Status Byte Message

After receiving a Serial Poll Enable bus command (SPE) and when addressed to talk, the CW Generator sends a Status Byte message. The message consists of one 8-bit byte which corresponds to the pattern shown in Table 3-4, Programming Quick Reference Guide.

3-36. Sending the Status Bit Message

The CW Generator sends the Status Bit message in response to the Parallel Poll Enable (PPE) bus command (whether or not it is addressed to talk). If the CW Generator is sending the Require Service message, it will set its assigned status bit true.

The data line that the parallel poll is assigned to respond on, and the sense (active high or active low) can be set from switches located inside the instrument. The selection procedure is described in Section II.

3-37. Receiving the Abort Message

The Abort message is the means by which the controller sets the Interface Clear (IFC) bus control line true. When the Abort message is received, the CW Generator becomes unaddressed and stops talking or listening.

Table 3-4. Programming Quick Reference Guide

PROGRAM STRING SYNTAX

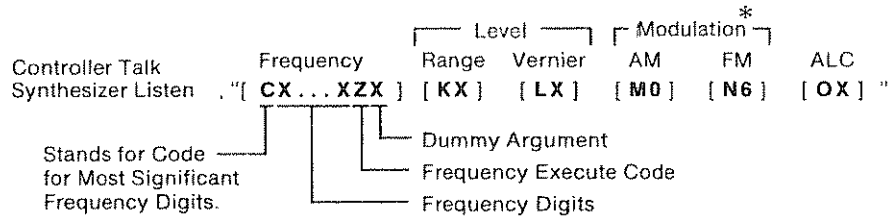

WHERE: C = PROGRAM CODE
 X = ARGUMENT OR FREQUENCY DIGIT

	PROGRAM CODES	ARGUMENTS
FREQUENCY	10 GHz @ or P	0 THROUGH 9
	1 GHz A or Q	
	100 MHz B or R	
	10 MHz C or S	
	1 MHz D or T	
	100 kHz E or U	
	10 kHz F or V	
	1 kHz G or W	
EXECUTE	J or Z	
OUTPUT LEVEL RANGE	K or [0 dB 0
		-10 1
		-20 2
		-30 3
		-40 4
		-50 5
		-60 6
		-70 7
		-80 8
		-90 9
		-100 :
-110 :		

	PROGRAM CODES	ARGUMENTS	
OUTPUT LEVEL VERNIER	L or \	+3 dBm 0	
		+2 1	
		+1 2	
		0 3	
		-1 4	
		-2 5	
		-3 6	
		-4 7	
		-5 8	
		-6 9	
-7 :			
-8 :			
-9 <			
-10 =			
AM	M or]*	OFF 0 or 1	
FM	N or)*	OFF 6 or 7	
ALC	PROGRAM CODES	ARGUMENTS	
		ALC	RF
		OFF	ON
0 or _	INT NORMAL	0	1
	INT, +10 RANGE	2	3
	XTAL, NORMAL	4	5
	XTAL, +10 RANGE	6	7
	MTR, NORMAL	<	=
	MTR, +10 RANGE	>	?

STATUS BYTE

Bit Number	8	7	6	5	4	3	2	1
Decimal Value	128	64	32	16	8	4	2	1
Function	CRYSTAL OVEN COLD	REQUEST SERVICE	OUT OF RANGE (Frequency)	RF OFF	NOT PHASE LOCKED	LEV UNCAL	0 (NOT USED)	+10 dB OVER RANGE

* Dummy codes for 8672A program compatibility.

OPERATOR'S CHECKS

3-38. OPERATOR'S CHECKS

3-39. Basic Functional Checks

Description The purpose of these checks is to give reasonable assurance that the instrument is operating properly.

Each check has been designed to be performed with a minimum of test equipment, and in as short a time as possible. Therefore, although these checks are extremely valuable in identifying malfunctions, they are not a substitute for the Performance Tests in Section IV, which verify that the instrument is performing within its published specifications.

Each check is independent of the others and can be performed separately.

If a malfunction is suspected and the CW Generator is being returned to Hewlett-Packard for service, perform the entire procedure. Document the checks that failed on a blue repair tag located at the rear of this manual and attach the tag to the instrument. This will help ensure that the malfunction has been accurately described to service technicians for the best possible service.

Equipment Attenuator, 10 dB HP 8491B, Option 010

Procedure **Turn-On Check**

1. Set the LINE switch to STANDBY. Remove all external cables from the front and rear panels of the CW Generator, including the power cable connecting the instrument to mains power.
2. Set the rear panel FREQ STANDARD INT/EXT switch to INT and connect the JUMPER (A3W3) between A3J9 and A3J10.
3. After the power cable has been disconnected from the CW Generator for at least 1 minute, reconnect it to the CW Generator. Check the front panel of the instrument to verify that the STANDBY and OVEN status annunciators are on.
4. Leave the instrument's LINE switch set to STANDBY until the OVEN status annunciator turns off. This should occur in 15 minutes or less, depending upon how long the CW Generator was disconnected from mains power. (The OVEN annunciator may flicker off and on temporarily just as the oven stabilization temperature is reached. This is normal operation.) Once the OVEN status annunciator is off set the LINE switch to ON.
5. Set the RF OUTPUT switch to ON. Set the FREQ STANDARD INT/EXT switch to EXT. Verify that the INTERNAL REF OFF and NOT PHASE LOCKED status annunciators turn on. Set the switch back to INT. The status annunciators should then turn off.

Frequency Check

The FREQUENCY MHz display and NOT PHASE LOCKED status annunciator are used to check that the internal phase-lock loops remain phase locked across their tuning range. The actual frequency at the RF OUTPUT connector is not

OPERATOR'S CHECKS

Basic Functional Checks (cont'd)**Procedure (cont'd)**

checked. However, the frequency can be monitored with a microwave frequency counter or spectrum analyzer for greater assurance that the CW Generator is operating properly.

If a frequency counter is to be used to check frequency, disconnect the jumper from the rear panel connector A3J10 and connect the frequency counter as shown in Figure 3-7. Set the CW Generator rear panel INT-EXT switch to EXT.

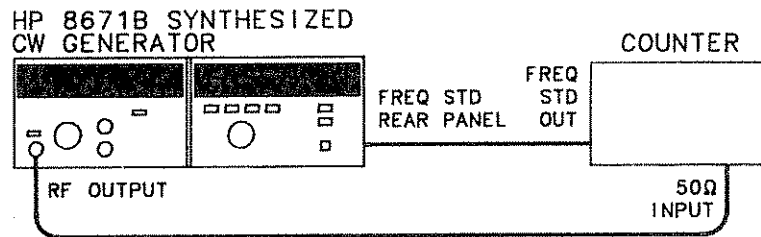

Figure 3-7. Frequency Checks Test Setup

6. Set the CW Generator as follows:

RF OUTPUT	OFF
PEAK-NORM control	NORM (in detent)
OUTPUT LEVEL RANGE selector	fully counter-clockwise
OUTPUT LEVEL VERNIER	fully counter-clockwise
ALC selector	INT
ALC CAL control	fully clockwise

7. Press the HOLD key. Verify that the CW Generator's displays indicate the following conditions:

RANGE dB display	-110 dB
Meter	<-10 dBm
ALC annunciator	INT and LVL UNCAL
RF annunciator	OFF
FREQUENCY MHz display	some frequency between 2.0 and 18.599997 GHz. If the display is not stable, press the PRESET (3 GHz) key.

FREQUENCY RESOLUTION display All four segments extinguished.

STATUS annunciators:

OVEN	may be on but should extinguish within 15 minutes after line cord is connected.
------	---

NOT PHASE LOCKED annunciator ON

All other annunciators should be extinguished.

OPERATOR'S CHECKS

Basic Functional Checks (cont'd)**Procedure
(cont'd)**

8. Press the PRESET (3 GHz) key and then the 100 MHz FREQUENCY RESOLUTION key. Verify that the leftmost segment in the FREQUENCY RESOLUTION display lights and that the other segments are extinguished.

NOTE

Do not tune above 6199.999 MHz in steps 9 through 17.

9. Verify that the displayed frequency can be tuned in 100 MHz increments using the TUNING knob.
10. Press the 1 MHz FREQUENCY RESOLUTION key. Verify that the two leftmost segments in the FREQUENCY RESOLUTION display are lighted and that the other segments are extinguished.
11. Verify that the displayed frequency can be tuned in 1 MHz increments using the TUNING knob.
12. Press the 10 kHz FREQUENCY RESOLUTION key. Verify that the three leftmost segments in the FREQUENCY RESOLUTION display are lighted and that the other segment is extinguished.
13. Verify that the displayed frequency can be tuned in 10 kHz increments using the TUNING knob.
14. Press the 1 kHz FREQUENCY RESOLUTION key. Verify that all segments in the FREQUENCY RESOLUTION display are lighted.
15. Verify that the displayed frequency can be tuned in 1 kHz increments using the TUNING knob.
16. Tune the frequency to 4 GHz and press the HOLD key. Verify that the four segments of the FREQUENCY RESOLUTION display are extinguished.
17. Press the PRESET (3 GHz) key and verify that the FREQUENCY RESOLUTION display indicates 3000.000 MHz.
18. Set the CW Generator as follows:
- | | |
|-----------------------------|----------------------------|
| RF OUTPUT | ON |
| PEAK-NORM control | NORM (in detent) |
| OUTPUT LEVEL RANGE selector | 0 dB range |
| OUTPUT LEVEL VERNIER | for 0 dBm reading on meter |
| ALC selector | INT |
| ALC CAL control | fully clockwise |
19. Tune the CW Generator frequency to 2 GHz and select 1 kHz FREQUENCY RESOLUTION. Slowly tune from 2000.000 MHz to 2000.010 MHz. Verify that the NOT PHASE LOCKED annunciator remains off at each step.
20. Set the frequency tuning resolution to the values shown in the following table. For each tuning resolution, slowly tune from the corresponding start frequency to the stop frequency. Each time, verify that the NOT PHASE LOCKED annunciator remains off. (Each phase-locked loop is tuned over its entire range.)
-

OPERATOR'S CHECKS

Basic Functional Checks (cont'd)**Procedure
(cont'd)**

FREQUENCY RESOLUTION	Start Frequency	Stop Frequency
10 kHz	2000.010 MHz	2001.000 MHz
1 MHz	2001.000 MHz	2100.000 MHz
100 MHz	2100.000 MHz	6200.000 MHz

21. Set the frequency to 18599.997 MHz (overrange). Verify that the NOT PHASE LOCKED annunciator remains off.

Output Level Check

The CW Generator's internal output leveling loop (ALC) is checked to ensure that it remains locked at all specified power levels. The internal output leveling loop monitors most of the RF output circuitry. The output level can be monitored with a power meter for greater assurance that the CW Generator is operating properly.

22. Press PRESET (3 GHz). Set the CW Generator as follows:
- | | |
|-----------------------------|-------------------------|
| RF OUTPUT | ON |
| PEAK-NORM control | NORM (in detent) |
| OUTPUT LEVEL RANGE selector | fully counter-clockwise |
| OUTPUT LEVEL VERNIER | fully counter-clockwise |
| ALC selector | INT |
| ALC CAL control | fully clockwise |
23. Connect a 50 ohm load or attenuator to the CW Generator's RF OUTPUT connector. This reduces unwanted power reflections back into the RF OUTPUT connector, thus avoiding a false LVL UNCAL annunciator indication.
24. Tune the frequency to 6200.000 MHz.
25. Using the OUTPUT LEVEL RANGE selector, step the output level range from -110 to +10 dB. Verify that the LVL UNCAL annunciator remains off.
26. Set OUTPUT LEVEL RANGE to 0 dBm and sweep the OUTPUT LEVEL VERNIER across its entire range. Verify that the annunciator remains off at all VERNIER settings.
27. Select 100 MHz frequency tuning resolution and set the output level to +8 dBm. Tune slowly from 2000.000 MHz to 18000.000 MHz. Verify that the indicated power level on the CW Generator's meter remains constant and stable and that the LVL UNCAL annunciator remains off. This ensures that the instrument can generate specified output power and remain leveled.

NOTE

Momentary flashing of the LVL UNCAL when tuning is normal. Make sure that it remains off after the meter has settled, at each frequency.

OPERATOR'S CHECKS

3-40. HP-IB Checks

DESCRIPTION: These procedures check the CW Generator's ability to process or send the HP-IB messages described in Table 3-3. Only the CW Generator, a controller, and an HP-IB controller interface (for the HP 85B) are needed to perform these checks.

These procedures do not check that all the CW Generator's program codes are being properly executed by the instrument. However, if the Basic Functional Checks and the HP-IB Checks all pass, then the instrument will probably execute all commands.

If the CW Generator fails any of these HP-IB checks, make sure the controller and interface are working properly.

The select code of the controller's HP-IB interface is assumed to be 7. The address of the CW Generator is assumed to be 19 (its factory-set address). This particular select code-address combination (that is, 719) is not necessary for these checks to be valid. However, the program lines presented here must be modified for any other combination.

Instructions for changing the address are in Section II, Installation.

These checks can be performed together or separately. Any special requirements for a check are described at the beginning of the check.

INITIAL SETUP: The test setup is the same for all of the HP-IB Checks. Connect the the CW Generator to the controller and set the CW Generator as follows:

RF Output switch	ON
PEAK-NORM control	NORM (in detent)
OUTPUT LEVEL RANGE selector	fully counter-clockwise
OUTPUT LEVEL VERNIER	fully clockwise
ALC selector	INT
CAL control	fully clockwise
Frequency	6000.000 MHz

EQUIPMENT: HP-IB Controller/Interface HP 85B/82937A
 — or —
 HP 9826A Option 011
 (BASIC 2.0 ROM Operating System)
 — or —
 HP 9836A with BASIC 2.0
 Operating System

Remote and Local Message

NOTE: This check determines whether the CW Generator properly switches from local to remote control and from remote to local control. If the instrument is in remote, switch the LINE switch to STANDBY, then to ON.

OPERATOR'S CHECKS

HP-IB Checks (cont'd)

Description	HP 85B (BASIC)	HP 9826A (BASIC) HP 9836A (BASIC)
Send the Remote message (by setting the Remote Enable bus control line, REN, true and addressing the CW Generator to listen).	REMOTE 719	REMOTE 719

OPERATOR'S RESPONSE: Check that the CW Generator's REMOTE annunciator is on and the OUTPUT LEVEL meter reads -10 dBm.

Send the Local message to the CW Generator.	LOCAL 719	LOCAL 719
---	-----------	-----------

OPERATOR'S RESPONSE: Check that the CW Generator's REMOTE annunciator is off and the OUTPUT LEVEL meter reads +3 dBm.

Receiving the Data Message

NOTE: This check determines whether the CW Generator properly receives Data messages.

Description	HP 85B (BASIC)	HP 9826A (BASIC) HP 9836A (BASIC)
Send the first part of the Remote message (enabling the CW Generator to remote.)	REMOTE 7	REMOTE 7
Address the CW Generator to listen (completing the Remote message), then send a Data message.	OUTPUT 719; "P18W0Z173075"	OUTPUT 719; "P18W0Z173075"

OPERATOR'S RESPONSE: Check that the CW Generator's REMOTE annunciator is on, RANGE dB indicates -70 dB, ALC annunciators show XTAL mode and LVL UNCAL, and the FREQUENCY MHz display shows 18000 MHz.

Sending the Data Message

NOTE: This check determines whether the CW Generator properly issues a Data message when addressed to talk. Before beginning this test, set the LINE switch to OFF, then to ON. (If an HP 9826A or 9836A controller is used, a short program is required to perform this check.)

OPERATOR'S CHECKS

HP-IB Checks (cont'd)

Description	HP 85B (BASIC)	HP 9826A (BASIC) HP 9836A (BASIC)
Send the Remote message.	REMOTE 719	10 REMOTE 719
Send a Data message to set the status byte.	OUTPUT 719; "M070"	20 OUTPUT 719; "M070"
Address the CW Generator to talk and store its output in variable V.	ENTER 719 using "#,B";V	30 V=0 40 ENTER 719 using "#,B";V
Display the value of V.	DISP V	50 DISP V 60 END

OPERATOR'S RESPONSE: Check that the CW Generator's REMOTE annunciator is on. The controller should display 28.

Receiving the Clear Message

NOTE: This check determines whether the CW Generator responds properly to the Clear message. This Check assumes that the CW Generator is in remote mode.

Description	HP 85B (BASIC)	HP 9826A (BASIC) HP 9836A (BASIC)
Send a Data message to initialize the CW Generator	Output 719; "P18W0Z173075"	Output 719; "P18W0Z173075"

OPERATOR'S RESPONSE: Check that the CW Generator is set to 18000 MHz, XTAL ALC mode, and RF OUTPUT ON.

Send the Clear message	CLEAR 719	CLEAR 719
------------------------	-----------	-----------

OPERATOR'S RESPONSE: Check that the CW Generator is set to 3000 MHz, INT ALC mode, and RF OUTPUT OFF.

Receiving the Abort Message

NOTE: This check determines whether the CW Generator becomes unaddressed when it receives the Abort message. This check assumes the CW Generator is in remote mode and at a frequency other than 2000 MHz.

OPERATOR'S CHECKS

HP-IB Checks (cont'd)

Description	HP 85B (BASIC)	HP 9826A (BASIC) HP 9836A (BASIC)
Address the CW Generator to listen and send part of a frequency message.	OUTPUT 719; "A2000"	OUTPUT 719; "A2000"
Send the Abort message, unaddressing the CW Generator from listening.	ABORTIO 7	ABORT 7
Address the controller to talk. The CW Generator is not addressed to listen.	SEND 7; MTA	SEND 7; MTA
Attempt to execute the previous frequency command by sending the frequency execute command.	OUTPUT 7; "Z1"	OUTPUT 7; "Z1"

OPERATOR'S RESPONSE: Check that the CW Generator does not display 2000 MHz output frequency. If the controller is an HP 9826A or 9836A, press the CLR I/O key to continue the checks.

Status Byte Message

NOTE: This check determines whether the CW Generator sends the Status Byte message. This check assumes that the Clear message has been sent.

Description	HP 85B (BASIC)	HP 9826A (BASIC) HP 9836A (BASIC)
Send the Serial Poll message to the CW Generator (causing it to send the Status Byte message). Display the value of the status byte.	S POLL(719)	S POLL(719)

OPERATOR'S RESPONSE: Check that the controller's display reads 28.

Require Service Message

NOTE: This check determines whether the CW Generator can issue the Require Service message (set the SRQ bus control line true). This check can be performed in either local or remote mode.

Description	HP 85B (BASIC)	HP 9826A (BASIC) HP 9836A (BASIC)
Send the Clear message	CLEAR 719	CLEAR 719
Send a Data message containing an out-of-range frequency. This causes the Require Service message to be sent.	OUTPUT 719; "P35Z1"	OUTPUT 719; "P35Z1"

OPERATOR'S CHECKS

HP-IB Checks (cont'd)

NOTE: If an HP 9826A or 9836A controller is being used, a short program is required for the next part of this check.

Description	HP 85B (BASIC)	HP 9826A (BASIC) HP 9836A (BASIC)
Read the binary status of the controller's HP-IB interface and store the data in variable V. In this step, 7 is the interface's select code, and 2 (HP-85B) and 7 (HP 9826A) are status registers for bus control lines.	STATUS 7,2;V	10 V=0 20 STATUS 7,7; V
Display the value of the SRQ bit. In this step, 5 (HP-85B) and 10 (HP 9826A or HP 9836A) are the SRQ bits for the controller, numbered from 0.	DISP "SRQ="; BIT(V,5)	30 DISP "SRQ =";BIT(V,10) 40 END

OPERATOR'S RESPONSE: Check that the SRQ value is 1, indicating that the CW Generator issued the Require Service message.

Status Bit Message

NOTE: This check determines whether the CW Generator sends the Status Bit message. This check can be performed in either local or remote mode. This check assumes that the Clear message has been sent.

Description	HP 85B (BASIC)	HP 9826A (BASIC) HP 9836A (BASIC)
Set up a Service Request condition by programming an illegal frequency.	OUTPUT 719; "P99Z1"	OUTPUT 719; "P99Z1"
Send the parallel poll message to the CW Generator (causing it to send the Status Bit message).	PPOLL(7)	PPOLL(7)

OPERATOR'S RESPONSE: Check that the controller displays 128, or the value of the bit that parallel poll switch is set to.

SECTION IV PERFORMANCE TESTS

4-1. INTRODUCTION

The procedures in this section test the instrument's electrical performance using the specifications of Table 1-1 as the performance standards. These tests are suitable for incoming inspection, troubleshooting, and preventive maintenance. All tests can be performed without accessing the interior of the instrument. A simpler operational test is included in Section III under Operator's Checks.

4-2. ABBREVIATED PERFORMANCE TEST

In most cases, it is not necessary to perform all of the tests in this section. The following tests should be performed after repairing the CW Generator or to verify instrument operation:

- Frequency Range and Resolution
- Output Level, High Level Accuracy and Flatness

These tests can also be used for incoming inspections and preventative maintenance. They are not intended to be a complete check of specifications, but will provide 90% confidence that the CW Generator is meeting its major performance specifications. These tests can be performed with less time and equipment than the full Performance Tests.

NOTE

To consider the performance tests valid, the following conditions must be met:

- a. The CW Generator must have a 1-hour warmup for all specifications.*
- b. The line voltage must be 100, 120, 220, or 240 Vac +5%, -10%.*
- c. The ambient temperature must be +15 to +35°C for the Output Level Flatness and RF Output Level and Accuracy tests; 0 to 55°C for all other tests.*

4-3. CALIBRATION CYCLE

This instrument requires periodic verification of performance to ensure that it is operating within

specified tolerances. The performance tests described in this section should be performed at least once each year; under conditions of heavy usage or severe operating environments, the tests should be more frequent. Adjustments that may be required are described in Section V, Adjustments.

4-4. PERFORMANCE TEST RECORD

Results of the performance tests may be tabulated in Table 4-3, Performance Test Record. The Performance Test Record lists all of the performance test specifications and the acceptable limits for each specification. If performance test results are recorded during an incoming inspection of the instrument, they can be used for comparison during periodic maintenance or troubleshooting. The test results may also prove useful in verifying proper adjustments after repairs are made.

4-5. EQUIPMENT REQUIRED

Equipment required for the performance tests is listed in Table 1-3, Recommended Test Equipment. Any equipment that satisfies the critical specifications given in the table may be substituted.

4-6. TEST PROCEDURES

It is assumed that the person performing the following tests understands how to operate the specified test equipment. Equipment settings, other than those for the CW Generator, are stated in general terms. For example, a test might require that a spectrum analyzer's resolution bandwidth be set to 100 Hz; however, the sweep time would not be specified and the operator would be expected to set that control and other controls as required to obtain an optimum display. It is also assumed that the technician will select the cables, adapters, and probes (listed in Table 1-3) required to complete the test setups illustrated in this section.

PERFORMANCE TESTS

4-7. FREQUENCY RANGE AND RESOLUTION TEST

Specification

Electrical Characteristics	Performance Limits	Conditions
FREQUENCY		
Range	2.0—18.0 GHz (Overrange to 18.599997 GHz)	
Resolution	1 kHz 2 kHz 3 kHz	2.0 to 6.2 GHz 6.2 to 12.4 GHz 12.4 to 18.0 GHz

Description

This test checks the resolution in each of three internal frequency bands using a frequency counter. The performance test is divided into a baseband check (2.0 to 6.2 GHz) and a check for bands 2 and 3 (6.2 to 12.4 GHz and 12.4 to 18.0 GHz respectively).

Equipment

Frequency Counter HP 5343A

Procedure

Baseband Test

1. Connect the equipment as shown in Figure 4-1. Set the CW Generator rear panel INT/EXT switch to EXT. Remove FREQ STANDARD jumper and connect A3J10 to the 10 MHz frequency standard output of the frequency counter.

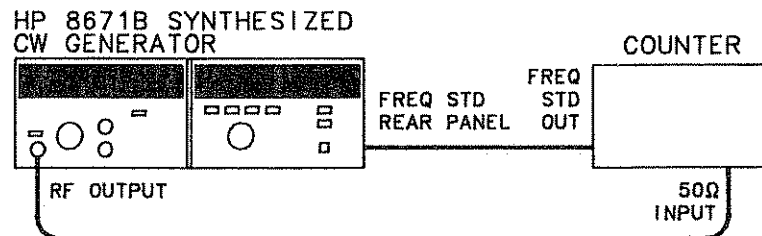

Figure 4-1. Frequency Range and Resolution Test Setup

2. Select 1 kHz display resolution on the counter.
3. Press the CW Generator's PRESET (3 GHz) key and set the output power to 0 dBm.
4. Verify that the frequency counter reads 3 000.000 MHz \pm 1 count.

2 999.999 MHz _____ 3 000.001 MHz
5. Set the CW Generator frequency to 2 000.000 MHz.
6. Tune to each of the frequencies listed below. Verify that the CW Generator remains phase locked at all frequencies and that the frequency counter agrees with the CW Generator frequency display \pm 1 count.

PERFORMANCE TESTS

FREQUENCY RANGE AND RESOLUTION (cont'd)

**Procedure
(cont'd)**

Frequency (MHz)	Minimum Frequency (MHz)	Actual Frequency (MHz)	Maximum Frequency (MHz)
2 000.000	1 999.999	_____	2 000.001
2 000.001	2 000.000	_____	2 000.002
2 001.112	2 001.111	_____	2 001.113
2 002.223	2 002.222	_____	2 002.224
2 003.334	2 003.333	_____	2 003.335
2 004.445	2 004.444	_____	2 004.446
2 005.556	2 005.555	_____	2 005.557
2 006.667	2 006.666	_____	2 006.668
2 007.778	2 007.777	_____	2 007.779
2 008.889	2 008.888	_____	2 008.890
2 009.999	2 009.998	_____	2 010.000

7. Set the CW Generator to 2 000.000 MHz.
8. Tune the CW Generator to each of the frequencies listed below and read the frequency counter at each step. The frequency counter reading should agree with the CW Generator front panel reading within ± 1 count. In addition, the CW Generator NOT PHASE LOCKED front panel annunciator should remain off at all frequencies.

NOTE

Fast tuning of frequency may cause the NOT PHASE LOCKED annunciator to flash on momentarily. This is normal and does not indicate a malfunction.

Frequency (MHz)	Minimum Frequency (MHz)	Actual Frequency (MHz)	Maximum Frequency (MHz)
2 090.000	2 089.999	_____	2 090.001
2 280.000	2 279.999	_____	2 280.001
2 470.000	2 469.999	_____	2 470.001
2 660.000	2 659.999	_____	2 660.001
2 850.000	2 849.999	_____	2 850.001
3 040.000	3 039.999	_____	3 040.001
3 230.000	3 229.999	_____	3 230.001
3 420.000	3 419.999	_____	3 420.001

(cont'd)

PERFORMANCE TESTS

FREQUENCY RANGE AND RESOLUTION (cont'd)
**Procedure
(cont'd)**

Frequency (MHz)	Minimum Frequency (MHz)	Actual Frequency (MHz)	Maximum Frequency (MHz)
3 610.000	3 609.999	_____	3 610.001
3 800.000	3 799.999	_____	3 800.001
3 990.000	3 989.999	_____	3 990.001
4 180.000	4 179.999	_____	4 180.001
4 370.000	4 369.999	_____	4 370.001
4 560.000	4 559.999	_____	4 560.001
4 750.000	4 749.999	_____	4 750.001
4 940.000	4 939.999	_____	4 940.001
5 130.000	5 129.999	_____	5 130.001
5 320.000	5 319.999	_____	5 320.001
5 510.000	5 509.999	_____	5 510.001
5 700.000	5 699.999	_____	5 700.001
5 900.000	5 899.999	_____	5 900.001
6 100.000	6 099.999	_____	6 100.001

Bands 2 and 3 Test

9. Tune the CW Generator to 10 000.000 MHz and select 1 kHz tuning resolution.
 10. Tune the frequency down one increment and verify that the CW Generator frequency display changes to 9 999.998 MHz and the frequency counter reading agrees within one count.
 11. Tune the frequency up two increments and verify that the CW Generator frequency display changes to 10 000.002 MHz. Verify also that the frequency counter reading agrees within one count.
10 GHz frequency resolution, 2 kHz _____ (✓)
 12. Tune the CW Generator to 18 000.000 MHz and select 1 kHz tuning resolution.
 13. Tune the frequency down one increment and verify that the CW Generator frequency display indicates 17 999.997 MHz and the frequency counter reading agrees within one count.
 14. Tune the frequency up two increments and verify that the CW Generator frequency display indicates 18 000.003 MHz and the frequency counter reading agrees within one count.
18 GHz frequency resolution, 3 kHz _____ (✓)
 15. Disconnect the frequency standard cable and replace the **FREQ STANDARD JUMPER** between A3J9 and A3J10. Set the INT/EXT switch to INT.
-

PERFORMANCE TESTS

4-8. FREQUENCY SWITCHING TIME TEST

Specification

Electrical Characteristics	Performance Limits	Conditions
SWITCHING TIME		
Frequency to be within the specified resolution.	<15 ms	
Amplitude to be within ± 3 dB of final level after switching frequency.	<15 ms	When switching within the same frequency resolution range.

Description

This test measures the frequency switching speed. The CW Generator is remotely programmed to continuously switch between two frequencies. Its output is mixed with a local oscillator whose output frequency is set to 1 kHz above the second (or destination) frequency. The difference frequency (IF) is displayed on an oscilloscope.

Frequency switching speed is first measured in the CW Generator's base band (2.0—6.2 GHz) using an IF frequency of 1 kHz (which is the specified resolution for the base band). As the unit under test is switched from the starting frequency to the destination frequency the oscilloscope is triggered by the HP-IB controller.

As the CW Generator output changes between the two programmed frequencies the IF signal will pass through zero. This will generate a phase reversal, as shown in Figure 4-3. The last phase change of the IF frequency is the point that the frequency of the unit under test is within the specified resolution.

The amplitude recovery time is tested using the same measurement setup. The ± 3 dB amplitude points of the IF signal are calibrated on the oscilloscope display and the amplitude recovery time is tested to ensure that the IF level is within ± 3 dB of the final level (see Figure 4-4). The amplitude recovery time is only specified for frequency changes within the same frequency resolution range.

NOTE

A digitizing oscilloscope will make this measurement easier due to the ability to store and view the switching process. The test may be performed without a digitizing oscilloscope by repetitively switching the frequency of the unit under test.

Equipment

HP-IB Controller	HP 85B/82903 or HP 9836A
Local Oscillator	HP 8340A
Mixer	RHG DMS1-18
Oscilloscope	HP 1980B

PERFORMANCE TESTS

FREQUENCY SWITCHING TIME TEST (cont'd)

Procedure

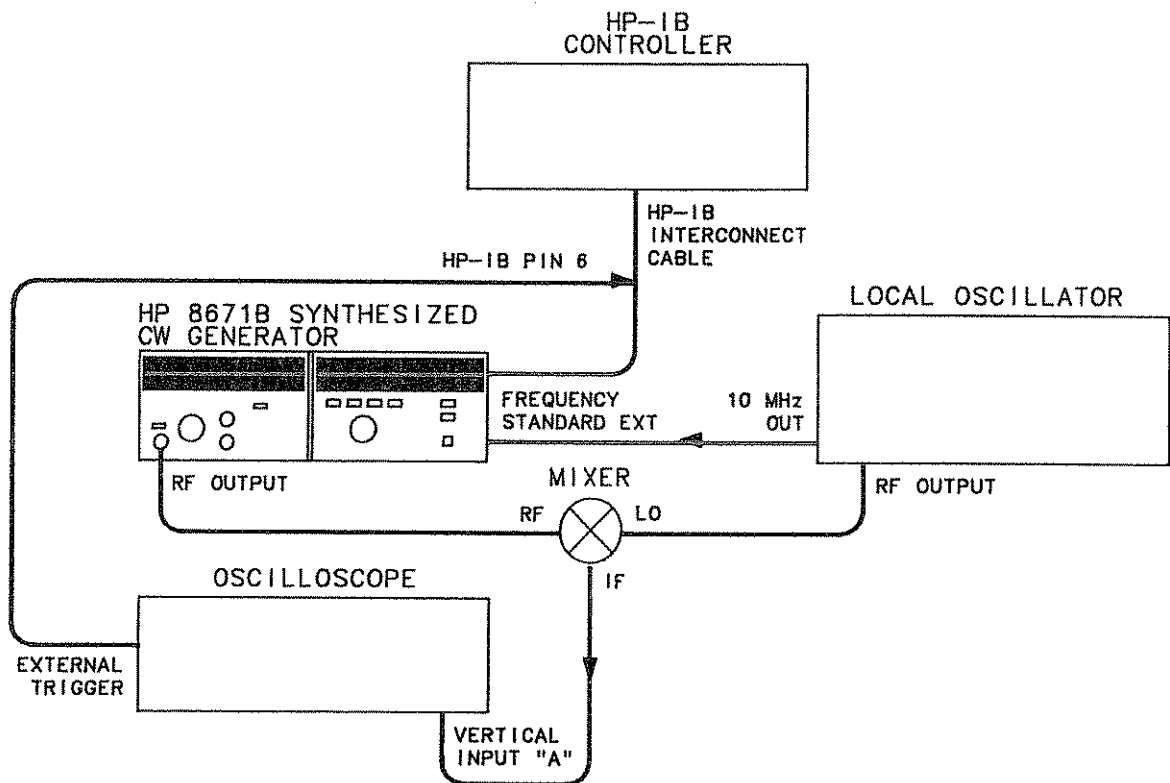

Figure 4-2. Frequency Switching Time Test Setup

Frequency Switching Time

1. Set up the equipment as shown in Figure 4-2. The external trigger input of the oscilloscope should be connected to pin 6 of the HP-IB cable. An HP-IB adapter (HP 10834A) can be used to make a permanent adapter for this test. This test may be performed by connecting the external trigger input of the oscilloscope to A2A7TP1. The test results should be identical for both methods of oscilloscope triggering.

WARNING

To access A2A7TP1 the instruments protective covers must be removed. This should only be done by service-trained personnel who are aware of the hazards involved (for example, fire and electrical shock).

2. Set the local oscillator to 2 100.001 MHz with an output level between +5 dBm and +8 dBm.
3. Set the oscilloscope to external trigger, positive slope trigger, triggered sweep mode (or NORMAL) and 2 ms per division sweep time.

PERFORMANCE TESTS

FREQUENCY SWITCHING TIME TEST (cont'd)**Procedure
(cont'd)****NOTE**

The following programs are for the HP 9826 or HP 9836 controller. For use with the HP 85B controller, increase the wait statements by a factor of 1000. This is done because the HP 85B executes wait commands in milliseconds while the HP 9836 and HP 9826 execute wait commands in seconds.

4. Load and run the following HP-IB controller program. As the program is executing, adjust the trigger controls for a stable 1 kHz sine wave display.

```

10 CLEAR 719
20 OUTPUT 719; "A2100000Z100075"
30 GOTO 20
40 END

```

2.1 GHz, +3 dBm, Ext ALC

5. Press the pause key on the controller to stop the program. Load and run the following program. The program will continue switching the CW Generator between 18 GHz and 2.1 GHz until the pause key is pressed. If necessary, adjust the oscilloscope triggering to obtain a display similar to that shown in Figure 4-3.

```

10 SEND 7; MTA LISTEN 19
20 OUTPUT 7; "K00075"
30 OUTPUT 7; "P18000000Z1"
40 WAIT .005
50 OUTPUT 7; "A2100000Z"
60 WAIT .7
70 OUTPUT 7; "1"
80 WAIT .05
90 GOTO 30
100 END

```

Controller talk, CW Generator listen

0 dB range, Ext ALC

Set to 18 GHz

5 for HP 85B (5 ms)

Ready for change to 2.1 GHz

700 for HP 85B (700 ms)

Change frequency

50 for HP 85B (50 ms)

PERFORMANCE TESTS

FREQUENCY SWITCHING TIME TEST (cont'd)

Procedure (cont'd)

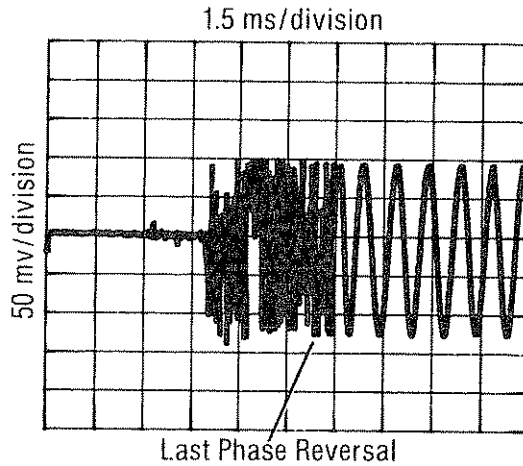

Figure 4-3. Frequency Switching Time Measurement Waveform

6. Measure the switching time by observing the signal on the oscilloscope display. The external trigger is the reference for determining switching speed. The switching time is measured from the display's left graticule to the last phase reversal (as the CW Generator passes the local oscillator frequency) before the IF signal settles into a steady frequency. Refer to Figure 4-3. Record the frequency switching time.

_____ <15 ms

7. Modify lines 30 and 50 to read as follows:

```

30  OUTPUT 7; "A2100000Z1"
50  OUTPUT 7; "P1800000Z"
    
```

Frequency 2.1 GHz

Frequency 18 GHz

8. Set the local oscillator frequency to 17 999.997 MHz.
9. Run the modified program and measure the switching time to the last phase reversal

_____ <15 ms

Amplitude Recovery Time

10. Set the local oscillator to 6 100.001 MHz.
11. Load and run the following program. Adjust the vertical sensitivity and position of the display until the displayed signal indicates a peak-to-peak change of exactly 2 divisions in amplitude. This calibrates the oscilloscope to ± 3 dB about 0 dBm. The smaller signal represents -3 dBm and the larger signal represents $+3$ dBm.

PERFORMANCE TESTS

FREQUENCY SWITCHING TIME TEST (cont'd)

```

Procedure
(cont'd)
10  CLEAR 719
20  OUTPUT 719; "A6100000Z1"
30  FOR X=1 TO 100
40  OUTPUT 719; "K00071"
50  NEXT X
60  FOR Y=1 TO 100
70  OUTPUT 719; "K06071"
80  NEXT Y
90  GOTO 30
100 END

```

Frequency 6.1 GHz
 Level +3 dBm
 Trigger oscilloscope
 Level -3 dBm

12. Set the top of the displayed signal to a convenient reference near the center of the display. Note the two levels for reference. The measurement will be determined by the time required before the amplitude of the IF signal stays between these two levels.
13. Press the pause key on the controller. Enter and run the following program. Run the program by typing RUN 110 and pressing the EXECUTE key (END LINE for the HP 85).

```

110 OUTPUT 719; "A2000000Z103071"
120 SEND 7; MTA LISTEN 19
130 OUTPUT 7; "A2100000Z1"
140 WAIT .005
150 OUTPUT 7; "A6100000Z"
160 WAIT .2
170 OUTPUT 7; "1"
180 WAIT .05
190 GOTO 130
200 END

```

2.0 GHz, 0 dBm, internal ALC
 Controller talk, CW generator listen
 Frequency 2.1 GHz
 5 for HP 85B (5 ms)
 Frequency 6.1 GHz
 700 for HP 85B (700 ms)
 Change frequency
 50 for HP 85B (50 ms)

PERFORMANCE TESTS

FREQUENCY SWITCHING TIME TEST (cont'd)

Procedure (cont'd)

14. Measure the amplitude recovery time. The measurement is the time from the left graticule of the display to the last time the IF signal amplitude is outside of the reference points noted in step 13. If necessary, adjust the oscilloscope triggering to obtain a display similar to that shown in Figure 4-4.

_____ <15 ms
 (Record Results for Step 17) _____ <15 ms
 (Record Results for Step 20) _____ <15 ms

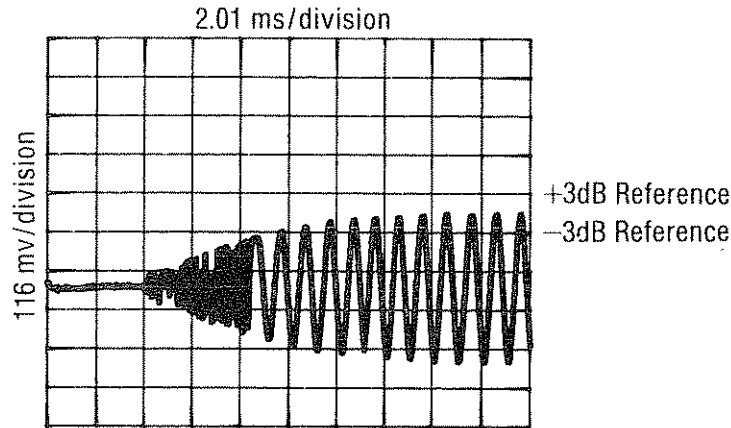

Figure 4-4. Amplitude Recovery Measurement Waveform

15. Set the local oscillator to 12 300.002 MHz.
16. Modify lines 20, 130, and 150 of the program as follows:

```

                20  OUTPUT 719; "P12300000Z1"
                130 OUTPUT 7; "A6200000Z1"
                150 OUTPUT 7; "P12300000Z1"
            
```
17. Repeat steps 11 through 14 using the modified programs. The amplitude recovery time will be measured for the 2 kHz resolution band.
18. Set the local oscillator to 18.000 003 GHz.
19. Modify lines 20, 130, and 150 of the program as follows:

```

                20  OUTPUT 719; "P18000000Z1"
                130 OUTPUT 7; "P12400000Z1"
                150 OUTPUT 7; "P1800000Z"
            
```
20. Repeat steps 11 through 14 using the modified program. The amplitude recovery time will be measured for the 3 kHz resolution band.
21. Disconnect the frequency reference from the rear panel and replace the jumper. Set the switch to INT.

PERFORMANCE TESTS

4-9. OUTPUT LEVEL, HIGH LEVEL ACCURACY AND FLATNESS TEST

Specification

Electrical Characteristics	Performance Limits	Conditions
RF OUTPUT		
Output Level: Leveled Output	+8 dBm to -120 dBm	+15 to +35°C
Remote Programming Absolute Level Accuracy (+15°C to +35°C)	±1.00 dB ±1.00 dB ±1.50 dB ±1.70 dB	2.0—6.2 GHz +10 dB output level range 0 dB output level range -10 dB output level range -20 dB output level range
	±1.25 dB ±1.25 dB ±1.75 dB ±1.95 dB	6.2—12.4 GHz +10 dB output level range 0 dB output level range -10 dB output level range -20 dB output level range
	±1.50 dB ±1.50 dB ±2.10 dB ±2.30 dB	12.4—18.0 GHz +10 dB output level range 0 dB output level range -10 dB output level range -20 dB output level range
Manual Absolute Level Accuracy	Add ±0.75 dB to remote programming absolute level accuracy	Absolute level accuracy specifications include allowances for detector linearity, temperature, flatness, attenuator accu- racy, and measurement uncertainty.
Flatness (0 dBm range; 15 to +35°C)	1.50 dB 2.00 dB 2.50 dB	2.0 to 6.2 GHz 2.0 to 12.4 GHz 2.0 to 18.0 GHz

Description

This test checks output level (maximum leveled power), absolute level accuracy between +8 dBm and -20 dBm, and output level flatness. The output level test uses a power meter to verify that +8 dBm can be generated over the full 2 to 18 GHz frequency range. Level flatness measures the variation in level over the various specified ranges. The high level accuracy test verifies that power levels between +8 dBm and -20 dBm are within the manual absolute level accuracy specification.

Equipment

Power MeterHP 436A
Power SensorHP 8481A

Procedure

Output Level Test

1. Connect the power sensor to the power meter. Calibrate and zero the power meter.
2. Connect the power sensor to the RF OUTPUT connector of the CW Generator as shown in Figure 4-5.

PERFORMANCE TESTS

OUTPUT LEVEL, HIGH LEVEL ACCURACY AND FLATNESS TEST (cont'd)

Procedure (cont'd)

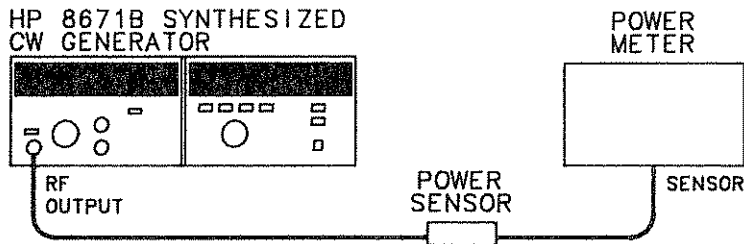

Figure 4-5. Output Level, High Level Accuracy and Flatness Test Setup

3. Set the CW Generator frequency to 2.0 GHz and the output level range to +10 dB.
4. Adjust the VERNIER control to give a power meter reading of +8 dBm.
5. Tune the CW Generator in 100 MHz steps from 2 to 18 GHz, adjusting the power meter's calibration factor and recording the frequency at which minimum power occurs. Reset VERNIER to read +8 dBm on the power meter at the recorded frequency to ensure that the +8 dBm power level can be met.

Frequency _____
 Minimum Power >+8 dBm _____

Level Flatness

6. Set the CW Generator frequency to 2 GHz, output level to -5 dBm, and power meter to dB Relative. Slowly tune to 6.2 GHz in 100 MHz steps and record the maximum and minimum relative power outputs. Set the power meter calibration factor appropriate for each frequency. Maximum variation should be within 1.5 dB (highest point to lowest point). Continue to tune to 12.4 GHz. Maximum variation should be within 2 dB. Continue to tune to 18.0 GHz and note level variation. Maximum variation should be less than 2.5 dB.

NOTE

The specification for power output flatness is not referenced to a particular frequency. The specification represents the total power variation over the entire frequency range.

2.0–6.2 GHz

Minimum _____
 Maximum _____
 Total Variation _____ <1.50 dB

2.0–12.4 GHz

Minimum _____
 Maximum _____
 Total Variation _____ <2.00 dB

PERFORMANCE TESTS

OUTPUT LEVEL, HIGH LEVEL ACCURACY AND FLATNESS TEST (cont'd)

**Procedure
(cont'd)** 2.0—18.0 GHz

Minimum _____
 Maximum _____
 Total Variation _____ <2.50 dB

High Level Accuracy Test

7. Connect the power sensor to the power meter. Calibrate and zero the power meter in the dBm mode.
8. Connect the power sensor to the RF OUTPUT connector of the CW Generator.
9. Set the CW Generator frequency to 2.0 GHz and output level to +8 dBm (+10 dB range and -2 dBm front panel meter setting).
10. Tune the CW Generator in 2 GHz steps from 2 to 18 GHz. Set the power meter's calibration factor appropriately and record the power output at each frequency in Table 4-1. The power meter readings should be within the limits specified.
11. Repeat steps 9 and 10 for an output level of +3 dBm (+10 dB range, -7 dBm VERNIER).
12. Set the CW Generator frequency to 2.0 GHz and output level to 0 dBm (0 dB range, 0 dBm VERNIER).
13. Tune the CW Generator in 2 GHz steps from 2 to 18 GHz. Set the power meter's calibration factor appropriately and record the power output at each frequency in Table 4-1. The power meter readings should be within the limits specified.
14. Repeat steps 12 and 13 for output levels of -5 dBm and -10 dBm (0 dB range).
15. Set the CW Generator frequency to 2.0 GHz and output level to -10 dBm (-10 dB range, 0 dBm VERNIER).
16. Tune the CW Generator in 2 GHz steps from 2 to 18 GHz. Set the power meter's calibration factor appropriately and record the power output at each frequency in Table 4-1. The power meter readings should be within the limits specified.
17. Repeat steps 15 and 16 for an output level of -20 dBm (-20 dB range, 0 dBm vernier).

PERFORMANCE TESTS

OUTPUT LEVEL, HIGH LEVEL ACCURACY AND FLATNESS TEST (cont'd)

Table 4-1. Output Level, High Level Accuracy and Flatness Test Record (1 of 2)

Test		Results		
		Min.	Actual	Max.
High Level Accuracy	+8 dBm (+10 dB range)	2 GHz	+ 6.25 dBm	+9.75 dBm
		4 GHz	+ 6.25 dBm	+9.75 dBm
		6 GHz	+ 6.25 dBm	+9.75 dBm
		8 GHz	+ 6.00 dBm	+10.00 dBm
		10 GHz	+ 6.00 dBm	+10.00 dBm
		12 GHz	+ 6.00 dBm	+10.00 dBm
		14 GHz	+ 5.75 dBm	+10.25 dBm
		16 GHz	+ 5.75 dBm	+10.25 dBm
		18 GHz	+ 5.75 dBm	+10.25 dBm
	+3 dBm (+10 dB range)	2 GHz	+ 1.25 dBm	+4.75 dBm
		4 GHz	+ 1.25 dBm	+4.75 dBm
		6 GHz	+ 1.25 dBm	+4.75 dBm
		8 GHz	+ 1.00 dBm	+5.00 dBm
		10 GHz	+ 1.00 dBm	+5.00 dBm
		12 GHz	+ 1.00 dBm	+5.00 dBm
		14 GHz	+ 0.75 dBm	+5.25 dBm
		16 GHz	+ 0.75 dBm	+5.25 dBm
		18 GHz	+ 0.75 dBm	+5.25 dBm
0 dBm (0 dB range)	2 GHz	- 1.75 dBm	+1.75 dBm	
	4 GHz	- 1.75 dBm	+1.75 dBm	
	6 GHz	- 1.75 dBm	+1.75 dBm	
	8 GHz	- 2.00 dBm	+2.00 dBm	
	10 GHz	- 2.00 dBm	+2.00 dBm	
	12 GHz	- 2.00 dBm	+2.00 dBm	
	14 GHz	- 2.25 dBm	+2.25 dBm	
	16 GHz	- 2.25 dBm	+2.25 dBm	
	18 GHz	- 2.25 dBm	+2.25 dBm	
-5 dBm (0 dB range)	2 GHz	-6.75 dBm	-3.25 dBm	
	4 GHz	- 6.75 dBm	-3.25 dBm	
	6 GHz	- 6.75 dBm	-3.25 dBm	
	8 GHz	- 7.00 dBm	-3.00 dBm	
	10 GHz	- 7.00 dBm	-3.00 dBm	
	12 GHz	- 7.00 dBm	-3.00 dBm	
	14 GHz	- 7.25 dBm	-2.75 dBm	
	16 GHz	- 7.25 dBm	-2.75 dBm	
	18 GHz	- 7.25 dBm	-2.75 dBm	
-10 dBm (0 dB range)	2 GHz	-11.75 dBm	-8.25 dBm	
	4 GHz	-11.75 dBm	-8.25 dBm	
	6 GHz	-11.75 dBm	-8.25 dBm	
	8 GHz	-12.00 dBm	-8.00 dBm	
	10 GHz	-12.00 dBm	-8.00 dBm	

PERFORMANCE TESTS

OUTPUT LEVEL, HIGH LEVEL ACCURACY AND FLATNESS TEST (cont'd)

Table 4-1. Output Level, High Level Accuracy and Flatness Test Record (2 of 2)

Test		Results		
		Min.	Actual	Max.
High Level Accuracy (cont'd) -10 dBm (0 dB range) (cont'd)	12 GHz	-12.00 dBm	_____	-8.00 dBm
	14 GHz	-12.25 dBm	_____	-7.75 dBm
	16 GHz	-12.25 dBm	_____	-7.75 dBm
	18 GHz	-12.25 dBm	_____	-7.75 dBm
-10 dBm (-10 dB range)	2 GHz	-12.25 dBm	_____	-7.75 dBm
	4 GHz	-12.25 dBm	_____	-7.75 dBm
	6 GHz	-12.25 dBm	_____	-7.75 dBm
	8 GHz	-12.50 dBm	_____	-7.50 dBm
	10 GHz	-12.50 dBm	_____	-7.50 dBm
	12 GHz	-12.50 dBm	_____	-7.50 dBm
	14 GHz	-12.85 dBm	_____	-7.15 dBm
	16 GHz	-12.85 dBm	_____	-7.15 dBm
	18 GHz	-12.85 dBm	_____	-7.15 dBm
-20 dBm (-20 dB range)	2 GHz	-22.45 dBm	_____	-17.55 dBm
	4 GHz	-22.45 dBm	_____	-17.55 dBm
	6 GHz	-22.45 dBm	_____	-17.55 dBm
	8 GHz	-22.70 dBm	_____	-17.30 dBm
	10 GHz	-22.70 dBm	_____	-17.30 dBm
	12 GHz	-22.70 dBm	_____	-17.30 dBm
	14 GHz	-23.05 dBm	_____	-16.95 dBm
	16 GHz	-23.05 dBm	_____	-16.95 dBm
18 GHz	-23.05 dBm	_____	-16.95 dBm	

PERFORMANCE TESTS

4-10. LOW LEVEL ACCURACY TEST**Specification**

Electrical Characteristics	Performance Limits	Conditions
RF OUTPUT Remote Programming Absolute Level Accuracy (+15 to +35°C)	± 1.90 dB ± 1.90 dB plus ± 0.3 dB per 10 dB step	2.0—6.2 GHz -30 dB output level range <-30 dB output level range
	± 2.15 dB ± 2.15 dB plus ± 0.3 dB per 10 dB step	6.2—12.4 GHz -30 dB output level range <-30 dB output level range
	± 2.40 ± 2.40 dB plus ± 0.4 dB per 10 dB step	12.4—18.0 GHz -30 dB output level range <-30 dB output level range
Manual Absolute Level Accuracy	Add ± 0.75 dB to remote pro- gramming absolute level accuracy	Absolute level accuracy specifications include allowances for detector line- arity, temperature, flatness, attenuator accuracy and measurement uncertainty.

Description

This test checks absolute level accuracy between -30 dBm and -110 dBm. An IF signal is calibrated to the spectrum analyzer by measuring the CW Generator's RF output at -20 dBm. A reference level corresponding to the -20 dBm output is set on the spectrum analyzer and each 10 dB decrease in range is checked for a 10 dB decrease on the spectrum analyzer display.

Equipment

Power Meter	HP 436A
Power Sensor	HP 8481A
Local Oscillator	HP 8340A
Mixer	RHG DMS 1-18
Spectrum Analyzer	HP 8566B
40 dB Amplifier	HP 8447F
20 dB Attenuator	HP 8491B Option 020
20 dB Preamplifier	HP 8447A

Procedure

1. Calibrate and zero the power meter in the dBm mode.
2. Connect the equipment as shown in Figure 4-6.

NOTE

Connect the mixer directly to the local oscillator to avoid any power loss.

PERFORMANCE TESTS

LOW LEVEL ACCURACY TEST (cont'd)

Procedure
(cont'd)

Figure 4-6. Low Level Accuracy Test Setup

3. Set the CW Generator frequency to 2 000.000 MHz, RANGE to -20 dB, and set the VERNIER for 0 dBm.
4. Adjust the VERNIER for a power meter reading of -20.00 dBm ± 0.01 dB.
5. Disconnect the power meter and connect the CW Generator to the mixer as shown in Figure 4-6.
6. Set the local oscillator to 2 000.100 MHz and output power to maximum but not greater than $+8$ dBm.
7. Set the resolution bandwidth on the spectrum analyzer to 300 Hz or less. Adjust the reference level so that the amplitude of the 100 kHz IF signal is set to a convenient horizontal graticule as a reference. This calibrates the graticule line for an absolute reference power level of -20 dBm. Enable the Delta Marker function on the spectrum analyzer, if available, for highest accuracy.
8. Set the range of the CW Generator 10 dB lower and adjust the CW Generator's VERNIER for a front panel meter reading of 0 dBm.
9. Set the spectrum analyzer reference level 10 dB lower to bring the signal level near the reference graticule line.

PERFORMANCE TESTS

LOW LEVEL ACCURACY TEST (cont'd)**Procedure
(cont'd)**

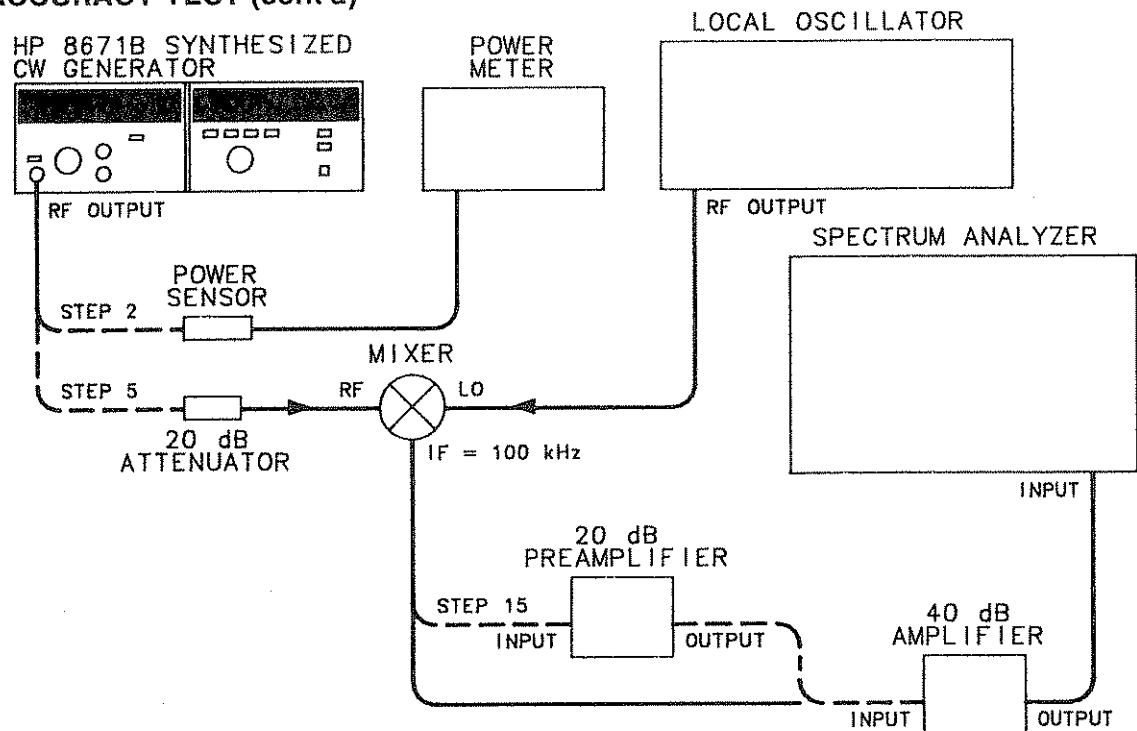
10. Read the difference between the displayed level and the reference graticule. Calculate the actual power as follows:

NOTE

The difference is positive if the signal is above the reference graticule line, and negative if below.

$$\begin{array}{r} \text{—————} \text{ Output level set in step 8.} \\ + \text{—————} \text{ Difference measured in step 10.} \\ \text{—————} \text{ Actual level.} \end{array}$$

Record the actual level calculated in Table 4-2. The level reading should be within the limits specified.

11. Repeat steps 8 through 10, with CW Generator range settings of -40 dB and -50 dB in step 8. Record the output level readings in Table 4-2.
12. Note the CW Generator's signal level (at -50 dBm) on the spectrum analyzer display. Remove the 20 dB attenuator, set the spectrum analyzer reference level 20 dB higher, and adjust the spectrum analyzer to bring the peak of the IF signal back to the same reference level.
13. Repeat steps 8 through 10 with CW Generator range settings of -60 dB through -90 dB. Record the output level readings in Table 4-2.
14. Note the CW Generator's level (at -90 dBm) on the spectrum analyzer display. This will be the reference in step 15.
15. Connect the 20 dB Preamplifier as shown in Figure 4-6. Set the spectrum analyzer IF sensitivity 20 dB higher, and set the vertical sensitivity to bring the signal back to the reference level noted in step 14.
16. Repeat steps 8 through 10, with CW Generator range settings of -100 dB and -110 dB. Record the output level readings in Table 4-2.
17. Repeat steps 3 through 16 for CW Generator frequencies of 10 GHz and 18 GHz. Record the output level readings in Table 4-2.

PERFORMANCE TESTS

LOW LEVEL ACCURACY TEST (cont'd)

Table 4-2. Low Level Accuracy Test Record

Test	Results		
	Min.	Actual	Max.
2.0 GHz			
-30 dBm	-32.65 dBm	_____	-27.35 dBm
-40 dBm	-42.95 dBm	_____	-37.05 dBm
-50 dBm	-53.25 dBm	_____	-46.75 dBm
-60 dBm	-63.55 dBm	_____	-56.45 dBm
-70 dBm	-73.85 dBm	_____	-66.15 dBm
-80 dBm	-84.15 dBm	_____	-75.85 dBm
-90 dBm	-94.45 dBm	_____	-85.55 dBm
-100 dBm	-104.75 dBm	_____	-95.25 dBm
-110 dBm	-115.05 dBm	_____	-104.95 dBm
10.0 GHz			
-30 dBm	-32.90 dBm	_____	-27.10 dBm
-40 dBm	-43.20 dBm	_____	-36.80 dBm
-50 dBm	-53.50 dBm	_____	-46.50 dBm
-60 dBm	-63.80 dBm	_____	-56.20 dBm
-70 dBm	-74.10 dBm	_____	-65.90 dBm
-80 dBm	-84.40 dBm	_____	-75.60 dBm
-90 dBm	-94.70 dBm	_____	-85.30 dBm
-100 dBm	-105.00 dBm	_____	-95.00 dBm
-110 dBm	-105.30 dBm	_____	-104.70 dBm
18.0 GHz			
-30 dBm	-33.45 dBm	_____	-26.55 dBm
-40 dBm	-43.85 dBm	_____	-36.15 dBm
-50 dBm	-54.25 dBm	_____	-45.75 dBm
-60 dBm	-64.65 dBm	_____	-55.35 dBm
-70 dBm	-75.05 dBm	_____	-64.95 dBm
-80 dBm	-85.45 dBm	_____	-74.55 dBm
-90 dBm	-95.95 dBm	_____	-84.15 dBm
-100 dBm	-106.35 dBm	_____	-93.75 dBm
-110 dBm	-107.75 dBm	_____	-103.35 dBm

PERFORMANCE TESTS

4-11. OUTPUT LEVEL SWITCHING TIME TEST

Specification Less than 20 ms to be within ± 1 dB of the final level.

Description This test measures the output level switching speed. The measuring system is set up to trigger the oscilloscope when the unit under test has finished accepting the output level data from the controller. The R.F. output is detected and coupled to the oscilloscope's vertical input. The time to complete switching (which includes settling time) is viewed on the oscilloscope display.

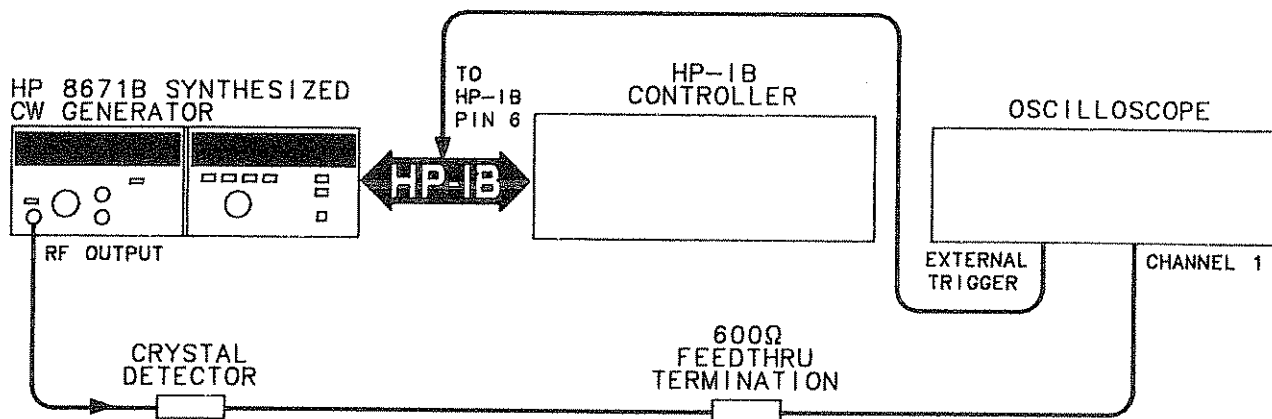

Figure 4-7. Output Level Switching Time Test Setup

Equipment	Oscilloscope	HP 1980B
	HP-IB Controller	HP 9836A or HP 85B/82903
	Crystal Detector	HP 8470B Opt. 012
	600 Ω Feedthru Termination	HP 11095A

- Procedure**
1. Set up the equipment as shown in Figure 4-7. The external trigger input of the oscilloscope should be connected to pin 6 of the HP-IB cable or A2A9U14, pin 15. An HP-IB adapter (HP 10834A) can be used to make a permanent trigger adapter for this test.

WARNING

To access A2A9U14 the instrument's protective cover must be removed. This should be performed only by service-trained personnel who are aware of the hazards involved (for example, fire and electrical shock).

PERFORMANCE TESTS

OUTPUT LEVEL SWITCHING TIME TEST (cont'd)

- Procedure (cont'd)**
- Set the oscilloscope for external triggering, positive trigger slope, triggered sweep mode (or NORM) and 2 ms per division sweep time.

NOTE

The following programs are for the HP 9826 or HP 9836 controller. For use with the HP 85B controller, increase the wait statements by a factor of 1000. This is necessary because the HP 9826 and HP 9836 execute wait commands in seconds while the HP 85B executes wait commands in milliseconds.

- Load and run the following HP-IB controller program. As the program is executing, adjust the trigger controls for a stable oscilloscope display.

```

10 CLEAR 719
20 OUTPUT 719: "A3000000Z103075"
30 GOTO 20
40 END

```

3.0 GHz, +3 dBm, Ext ALC

- Press the pause key on the controller. Load the following HP-IB controller program.

```

10 SEND 7;MTA LISTEN 19
20 FOR X=1 TO 50
30 OUTPUT 7; "K0"
40 WAIT .03
50 OUTPUT 7; "K"
60 WAIT .7
70 OUTPUT 7; ";"
80 WAIT .05
90 NEXT X
100 END

```

Controller talk, CW Generator listen

0 dB range, Ext ALC

30 for HP 85B (30 ms)

Ready for change to -110 dB Range

700 for HP 85B (700 ms)

Change to -110 dB Range

50 for HP 85B (50 ms)

PERFORMANCE TESTS

OUTPUT LEVEL SWITCHING TIME TEST (cont'd)

Procedure (cont'd)

NOTE

Run this program only as long as necessary to make the level switching measurements. This measurement cycles the attenuator which causes mechanical wear. The program limits the number of cycles to 50, however, if a digitizing oscilloscope is available only one cycle is needed.

- 5. Run the program and measure the switching time by observing the signal on the oscilloscope display. Refer to Figure 4-8.

_____ <20 ms

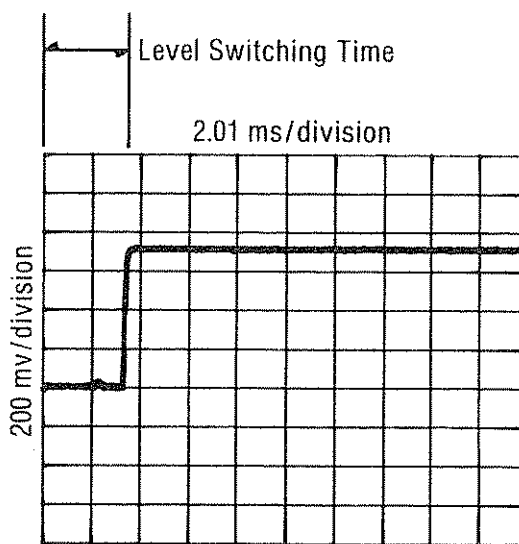

Figure 4-8. Output Level Switching Time Measurement Waveform

PERFORMANCE TESTS

4-12. HARMONICS, SUBHARMONICS, & MULTIPLES TEST

Specification

Electrical Characteristics	Performance Limits	Conditions
SPECTRAL PURITY		
Harmonics	<-25 dBc	Output level +8 dBm
Subharmonics and Multiples Thereof	<-25 dBc	Output level +8 dBm

Description

This test checks the amplitude of various harmonics of the CW Generator's output signal in the multiplied frequency bands (>6.2 GHz), subharmonics and multiples (harmonics of the internal fundamental signal) are also checked for specific levels. Reasonable care must be taken to ensure that the harmonics are not being generated by the spectrum analyzer.

Equipment

Spectrum AnalyzerHP 8566B

Procedure

1. Connect the CW Generator RF OUTPUT to the input of the spectrum analyzer as shown in Figure 4-9.

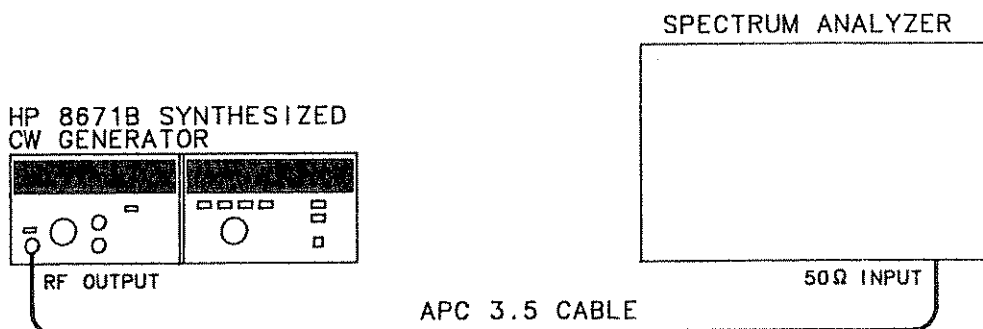

Figure 4-9. Harmonics, Subharmonics, and Multiples Test Setup

2. Tune the CW Generator to 4 000.000 MHz and output level of +8 dBm.
 3. Set the spectrum analyzer controls to display the fundamental signal. Set the resolution bandwidth to 10 kHz and the input attenuation to 40 dB. Adjust the log reference level to set the displayed signal at the top graticule line of the display.
 4. Tune the CW Generator to 2 000.000 MHz. The second harmonic, now displayed at 4 000.000 MHz, should be greater than 25 dB below the reference.
- _____ <-25 dBc
5. Repeat steps 2 through 4, at the other CW Generator frequencies listed, to check each harmonic, subharmonic, and multiple listed in the following table. Record the measurements in Table 4-3.

PERFORMANCE TESTS

HARMONICS, SUBHARMONICS, & MULTIPLES TEST (cont'd)

**Procedure
(cont'd)**

NOTE

This procedure may be repeated for any fundamental frequency of interest within the CW Generator frequency range.

Harmonics, Subharmonics, and Multiples

Set Signal Generator to	Check Harmonic Levels at:			
	FUNDAMENTAL	HARMONIC	SUBHARMONIC	
(GHz)	(GHz)	1/3	1/2	2/3
2.000 000	4.000 000			
4.000 000	8.000 000			
6.000 000	12.000 000			
8.000 000	16.000 000		4.000 000	
10.000 000	20.000 000		5.000 000	
11.000 000	22.000 000		5.500 000	
14.000 000		4.666 667		9.333 333
16.000 000		5.333 333		10.666 667
18.000 000		6.000 000		12.000 000
LIMITS	<-25 dBc	-25 dBc		

PERFORMANCE TESTS

HARMONICS, SUBHARMONICS, & MULTIPLES TEST (cont'd)

Table 4-3. Harmonics, Subharmonics & Multiples Test Record

Test		Results		
		Min.	Actual	Max.
Fundamental	Harmonic or Subharmonic			
2.000 000 GHz	4.000 000 GHz 2f		_____	-25 dBc
4.000 000 GHz	8.000 000 GHz 2f		_____	-25 dBc
6.000 000 GHz	12.000 000 GHz 2f		_____	-25 dBc
8.000 000 GHz	16.000 000 GHz 2f		_____	-25 dBc
8.000 000 GHz	4.000 000 GHz 1/2f		_____	-25 dBc
10.000 000 GHz	20.000 000 GHz 2f		_____	-25 dBc
10.000 000 GHz	5.000 000 GHz 1/2f		_____	-25 dBc
11.000 000 GHz	22.000 000 GHz 2f		_____	-25 dBc
11.000 000 GHz	5.000 000 GHz 1/2f		_____	-25 dBc
14.000 000 GHz	4.666 667 GHz 1/3f		_____	-25 dBc
14.000 000 GHz	9.33 3333 GHz 2/3f		_____	-25 dBc
16.000 000 GHz	5.333 333 GHz 1/3f		_____	-25 dBc
16.000 000 GHz	10.666 667 GHz 2/3f		_____	-25 dBc
18.000 000 GHz	6.000 000 GHz 1/3f		_____	-25 dBc
18.000 000 GHz	12.000 000 GHz 2/3f		_____	-25 dBc

PERFORMANCE TESTS

4-13. NON-HARMONICALLY RELATED SPURIOUS SIGNALS TEST

Specification

Electrical Characteristics	Performance Limits	Conditions
SPECTRAL PURITY		
Spurious		
Non-Harmonically	<-70 dBc	2.0 to 6.2 GHz
Related	<-64 dBc	6.2 to 12.4 GHz
	<-60 dBc	12.4 to 18.0 GHz

Description

This test checks for any spurious signals in the CW Generator's RF output signal. The spectrum analyzer is calibrated for a reference level of -50 dBc and is tuned to any frequency from 2.0 to 6.2 GHz in search of spurious signals.

NOTE

The non-harmonically related spurious signals will always increase in amplitude above 6.2 GHz, due to multiplication in the internal YIG tuned multiplier. The increase is determined by a strict mathematical relationship. Therefore, satisfactory performance in the 2 to 6.2 GHz range will always ensure meeting the less stringent specification in the multiplied ranges, that is, from 6.2 to 18.0 GHz.

Equipment

Spectrum Analyzer HP 8566B

Procedure

1. Connect the CW Generator's RF OUTPUT to the input of the spectrum analyzer as shown in Figure 4-10.

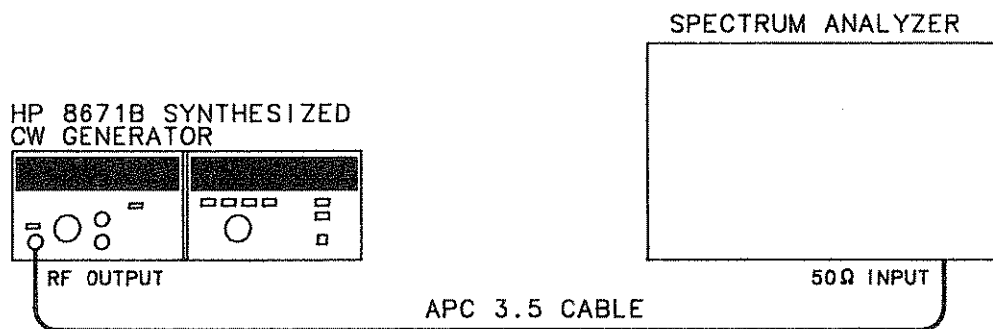

Figure 4-10. Non-Harmonically Related Spurious Signals Test Setup

2. Tune the CW Generator to 3 000.000 MHz and set the output level to -50 dBm.
3. Set the spectrum analyzer controls to display the fundamental signal. Set the resolution bandwidth to 1 kHz and the frequency span per division to 10 kHz.
4. Set the spectrum analyzer controls so that the carrier signal is at the top graticule line.

PERFORMANCE TESTS

NON-HARMONICALLY RELATED SPURIOUS SIGNALS TEST (cont'd)

Procedure (cont'd)

- 5. Using the RANGE selector, increase the CW Generator's output level to 0 dBm. Do not adjust the spectrum analyzer amplitude calibration. The top graticule line now represents -50 dBc.
- 6. Tune the spectrum analyzer to any desired frequency in search of non-harmonically related spurious signals. Verify that any signals found are non-harmonically related and are not generated by the spectrum analyzer. Verify that the spurious signals are below the specified limits. Record the results.

Carrier Frequency	Spurious Signal Frequency	Spurious Signal Level
3 000 MHz	_____	_____
3 000 MHz	_____	_____

- 7. Repeat step 2 through 6 for any desired carrier frequency from 2 000.000 to 6 199.999 MHz. Record the results. (Checking non-harmonically related spurious signals from 2.0 to 6.2 GHz provides a high level of confidence that the instrument meets its published specifications from 2 to 18 GHz.)

Carrier Frequency	Spurious Signal Frequency	Spurious Signal Level
_____	_____	_____
_____	_____	_____
_____	_____	_____

PERFORMANCE TESTS

4-14. POWER LINE RELATED SPURIOUS SIGNALS TEST

Specification

Electrical Characteristics	Performance Limits	Conditions
SPECTRAL PURITY Power line related and fan rotation related within 5 Hz below line frequencies and multiples thereof	-50 dBc -60 dBc -65 dBc -44 dBc -54 dBc -59 dBc -40 dBc -50 dBc -55 dBc	2.0—6.2 GHz <300 Hz offset from carrier 300 Hz to 1 kHz offset from carrier >1 kHz offset from carrier 6.2—12.4 GHz <300 Hz offset from carrier 300 Hz to 1 kHz offset from carrier >1 kHz offset from carrier 12.4—18.0 GHz <300 Hz offset from carrier 300 Hz to 1 kHz offset from carrier >1 kHz offset from carrier

Description

The Unit Under Test and local oscillator are isolated from vibration by placing the instruments on two-inch thick foam pads. This eliminates the effects of microphonic spurious signals due to vibrations..

The primary power source is isolated from the power source used for the spectrum analyzer and the local oscillator to differentiate the power line related spurious signals from other power line related spurious signals.

NOTE

The Unit Under Test must be operated at a power line frequency different than that of the local oscillator and spectrum analyzer. This avoids the summing of the power line spurious signals.

Equipment

- Local Oscillator HP 8340A
- Spectrum Analyzer HP 3580A
- Mixer RHG DMS1-18
- Variable Frequency AC Power Source 501TC/800T,
California Instruments

Procedure

1. Place the CW Generator on a 2-inch foam pad. Connect the equipment as shown in Figure 4-11.

NOTE

Connect the mixer directly to the local oscillator to avoid any power loss.

PERFORMANCE TESTS

POWER LINE RELATED SPURIOUS SIGNALS TEST (cont'd)**Procedure
(cont'd)**

Figure 4-11. Power Line Related Spurious Signals Test Setup

2. Tune the CW Generator to 3 000.000 MHz and set the output level to -20 dBm.
3. Set the local oscillator to 3 000.020 MHz at $+7$ dBm.
4. Set the spectrum analyzer start frequency to 20 kHz, resolution bandwidth to 3 Hz.
5. Set the spectrum analyzer frequency span per division to 50 Hz. Set the spectrum analyzer controls so the peak of the 20 kHz signal is at the top graticule line. Verify that the line related spurious signals of the CW Generator do not exceed the values shown below. Record the highest spurious signal level in each offset band.

2.0 — 6.2 GHz <300 Hz offset _____ -50 dBc

300 Hz — 1 kHz offset _____ -60 dBc

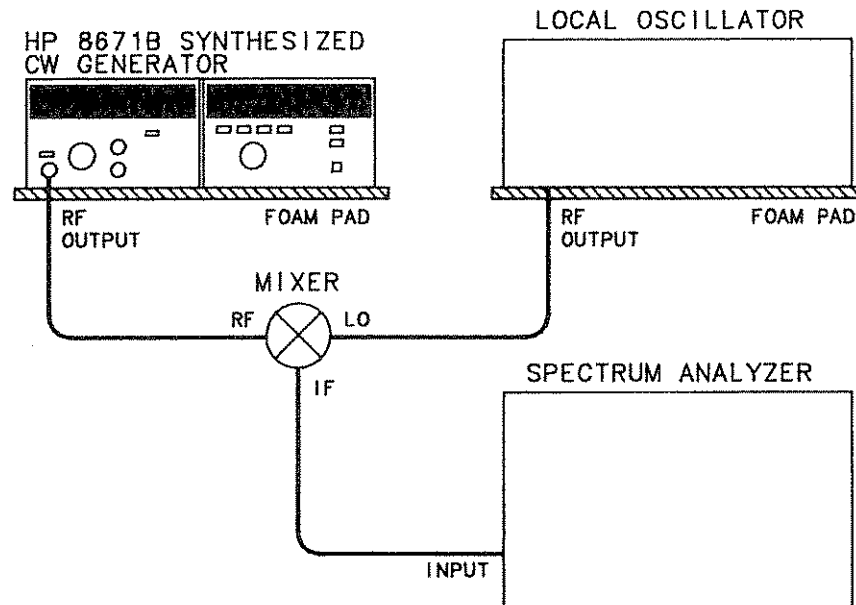
6. Set the spectrum analyzer frequency span per division to 500 Hz. Measure and record the highest spurious signal level.

2.0 — 6.2 GHz >1 kHz offset _____ -65 dBc

7. Tune the CW Generator and the local oscillator to 7 000.000 MHz and 7 000.020 MHz respectively.
-

PERFORMANCE TESTS

POWER LINE RELATED SPURIOUS SIGNALS TEST (cont'd)**Procedure
(cont'd)**

8. Set the spectrum analyzer frequency span per division to 50 Hz. Set the spectrum analyzer controls so that the peak of the 20 kHz signal is at the top graticule line. Verify that the line related spurious signals of the CW Generator do not exceed the values shown below. Record the highest spurious signal level in each offset band.

6.2 — 12.4 GHz <300 Hz offset frequency _____ -44 dBc

300 Hz — 1 kHz offset frequency _____ -54 dBc

9. Set the spectrum analyzer frequency span per division to 500 Hz. Measure and record the spurious signal levels.

6.2 — 12.4 GHz >1 kHz offset frequency _____ -59 dBc

10. Tune the CW Generator and the local oscillator to 16 000.000 MHz and 16 000.020 MHz respectively.

11. Set the spectrum analyzer frequency span per division to 50 Hz. Set the spectrum analyzer controls so that the 20 kHz signal is at the top graticule line. Verify that the line related spurious signals of the CW Generator do not exceed the values shown in the table. Record the highest spurious signal level in each offset band.

12.4 — 18.0 GHz <300 Hz offset frequency _____ -40 dBc

300 Hz — 1 kHz offset frequency _____ -50 dBc

12. Set the spectrum analyzer frequency span per division to 500 Hz. Measure and record the spurious signal levels.

12.4 — 18.0 GHz >1 kHz offset frequency _____ -55 dBc

PERFORMANCE TESTS

4-15. SINGLE-SIDEBAND PHASE NOISE TEST

Specification

Electrical Characteristics	Performance Limits	Conditions
SPECTRAL PURITY Single-sideband Phase Noise (1 Hz bandwidth)	-58 dBc -70 dBc -78 dBc -86 dBc -110 dBc -52 dBc -64 dBc -72 dBc -80 dBc -104 dBc -48 dBc -60 dBc -68 dBc -76 dBc -100 dBc	2.0 — 6.2 GHz 10 Hz offset from carrier 100 Hz offset from carrier 1 kHz offset from carrier 10 kHz offset from carrier 100 kHz offset from carrier 6.2 — 12.4 GHz 10 Hz offset from carrier 100 Hz offset from carrier 1 kHz offset from carrier 10 kHz offset from carrier 100 kHz offset from carrier 12.4 — 18.0 GHz 10 Hz offset from carrier 100 Hz offset from carrier 1 kHz offset from carrier 10 kHz offset from carrier 100 kHz offset from carrier

Description

The RF output of the CW Generator is mixed with a local oscillator to obtain a 40 kHz or 200 kHz IF signal. The phase noise sidebands are observed on a spectrum analyzer. Correction factors are applied to compensate for using the spectrum analyzer in the log mode, for local oscillator noise contributions, and for using bandwidths wider than 1 Hz.

NOTE

Normally, phase quadrature needs to be maintained between the CW Generator and the local oscillator for true phase noise measurement. However, the additional amplitude noise components are so small that they are not significant in these tests.

Equipment

- Local Oscillator HP 8340A
- Low Frequency Spectrum Analyzer HP 3580A
- High Frequency Spectrum Analyzer HP 8566B
- Mixer RHG DMS1-18

PERFORMANCE TESTS

SINGLE-SIDEBAND PHASE NOISE TEST (cont'd)**NOTE**

The signal-to-phase noise ratio as measured must be corrected to compensate for 3 errors contributed by the measurement system. These are

- a. Using the spectrum analyzer in the log mode requires a +2.5 dB correction.
- b. Equal noise contributed by the local oscillator requires a -3 dB correction.
- c. The spectrum analyzer noise measurement must be normalized to a 1 Hz noise equivalent bandwidth. The noise equivalent bandwidth for HP spectrum analyzers is 1.2 times the 3 dB bandwidth.

For a 3 Hz bandwidth, the correction factor for the normalized measurement bandwidth would be:

$$\begin{aligned} \text{Normalizing Factor dB} &= 10 \log (1.2 \times 3 \text{ Hz}/1\text{Hz}) \\ &= 5.56 \text{ dB.} \end{aligned}$$

The total correction for 3 Hz bandwidth would be:

$$\text{True measurement (dBc)} = \text{Reading (dBc)} - 5.56 + 2.5 - 3 = \text{Reading (dBc)} - 6.06 \text{ dB.}$$

Procedure

1. Set the low frequency spectrum analyzer's start frequency to 40 kHz, resolution bandwidth to 1 Hz, and frequency span per division to 5 Hz.
2. Connect the equipment as shown in Figure 4-12.

NOTE

Connect the mixer directly to the local oscillator to avoid any power loss.

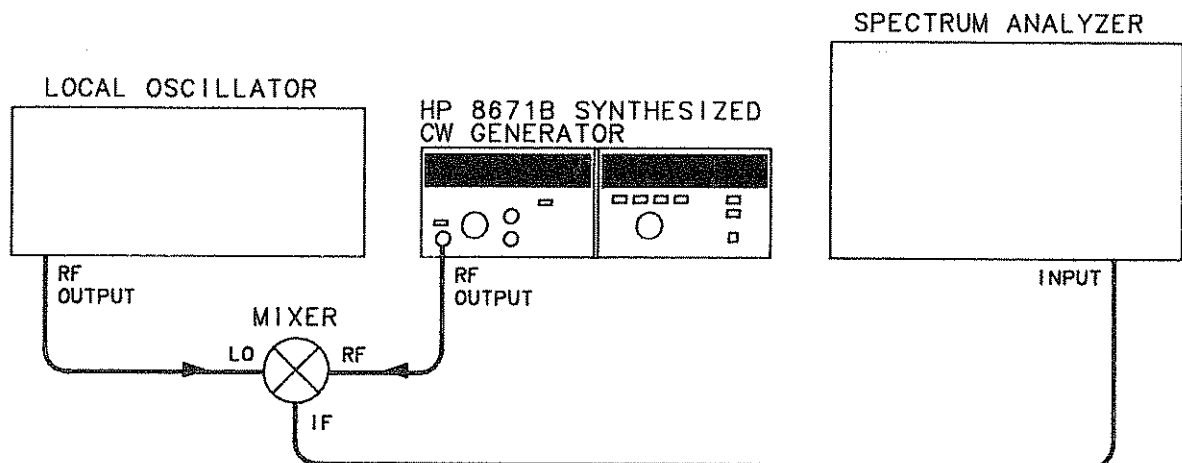

Figure 4-12. Single-Sideband Phase Noise Test Setup

3. Tune the CW Generator to 6 100.000 MHz and set the output level to -20 dBm.
 4. Set the local oscillator to 6 100.040 MHz at +8 dBm.
-

PERFORMANCE TESTS

SINGLE-SIDEBAND PHASE NOISE TEST (cont'd)

Procedure (cont'd)

- 5. Set the spectrum analyzer controls so that the peak of the 40 kHz signal is at the top graticule line.
- 6. Observe the phase noise level 10 Hz from the carrier. It should be greater than 56.7 dB below the carrier. Record the measured level.

Measured _____
 Correction -1.30 dB
 Actual level _____ <-58 dBc

- 7. Tune the CW Generator and the local oscillator to 12 200.000 MHz and 12 200.040 MHz respectively.

- 8. Observe the phase noise level 10 Hz from the carrier. It should be greater than 50.07 dB below the carrier. Record the measured level.

Measured _____
 Correction -1.30 dB
 Actual level _____ <-52 dBc

- 9. Tune the CW Generator and the local oscillator to 18 000.000 MHz and 18 000.039 MHz respectively.

- 10. Observe the noise level 10 Hz from the carrier. It should be greater than 46.7 dB below the carrier. Record the measured level.

Measured _____
 Correction -1.30 dB
 Actual level _____ <-48 dBc

- 11. Set the spectrum analyzer controls for a resolution bandwidth of 3 Hz and a frequency span per division of 20 Hz. Using a 3 Hz bandwidth requires a 6.06 dB correction factor.

- 12. Repeat steps 3 through 10 except observe the noise 100 Hz from the carrier. Record the results below.

Frequency	Measured	Correction	Actual	Limit
6100.000 MHz	_____	-6.06 dB =	_____	-70 dBc
12 200.000 MHz	_____	-6.06 dB =	_____	-64 dBc
18 000.000 MHz	_____	-6.06 dB =	_____	-60 dBc

- 13. For the remainder of this procedure, use the high frequency spectrum analyzer. Set the spectrum analyzer resolution bandwidth to 30 Hz and frequency span per division to 200 Hz. The 30 Hz bandwidth requires 16.06 dB correction.

- 14. Tune the CW Generator and the local oscillator to 6 100.000 MHz and 6 100.200 MHz respectively.

PERFORMANCE TESTS

SINGLE-SIDEBAND PHASE NOISE TEST (cont'd)

Procedure (cont'd)

15. Tune the spectrum analyzer to place the 200 kHz IF signal at the left edge of the display. Set the spectrum analyzer controls to place the peak of the signal at the top graticule line. Increase the log reference level control to move the peak of the carrier 20 dB above the top graticule line. (The top graticule line is now -20 dBc.)

16. Observe the phase noise level 1 kHz from the carrier. The observed level should be greater than 62 dB below the carrier. Record the measured level.

Measured _____
 Correction -16.06 dB
 Actual Level _____ < -78 dBc

17. Tune the CW Generator and the local oscillator to 12 200.000 MHz and 12 200.200 MHz respectively.

18. Observe the noise level 1 kHz from the carrier. The observed level should be greater than 56 dB below the carrier. Record the measured level.

Measured _____
 Correction -16.06 dB
 Actual Level _____ < -72 dBc

19. Tune the CW Generator and the local oscillator to 18 000.000 MHz and 18 000.200 MHz respectively.

20. Observe the noise level 1 kHz from the carrier. The observed level should be greater than 52 dB below the carrier. Record the measured level.

Measured _____
 Correction -16.06 dB
 Actual Level _____ < -68 dBc

21. Set the spectrum analyzer for a resolution bandwidth of 300 Hz and a frequency span per division of 2 kHz. Using a 300 Hz bandwidth requires a 26.06 dB correction factor.

22. Repeat steps 14 through 20 except observe the noise 10 kHz from the carrier. Record the results below.

Frequency	Measured	Correction	Actual	Limit
6100.000 MHz	_____	-26.06 dB	_____	-86 dBc
12 200.000 MHz	_____	-26.06 dB =	_____	-80 dBc
18 000.000 MHz	_____	-26.06 dB =	_____	-76 dBc

23. Set the spectrum analyzer controls for a resolution bandwidth of 3 kHz and a frequency span per division of 20 kHz. Using a 3 kHz bandwidth requires a 36.06 dB correction factor.

PERFORMANCE TESTS

SINGLE-SIDEBAND PHASE NOISE TEST (cont'd)

Procedure (cont'd) 24. Repeat steps 14 through 20 except observe the noise 10 kHz from the carrier. Record the results below.

Frequency	Measured	Correction	Actual	Limit
6100.000 MHz	_____	-36.06 dB =	_____	-110 dBc
12 200.000 MHz	_____	-36.06 dB =	_____	-100 dBc
18 000.000 MHz	_____	-36.06 dB =	_____	-100 dBc

PERFORMANCE TESTS

4-16. INTERNAL TIME BASE AGING RATE

Specification

Electrical Characteristics	Performance Limits	Conditions
FREQUENCY Reference Oscillator Frequency Aging Rate Accuracy and Stability	10 MHz $<5 \times 10^{-10}/\text{day}$ Same as reference oscillator	After a 10 day warmup (typically 24 hours in a normal operating environment)

Description

A reference signal from the CW Generator (10 MHz OUT) is connected to the oscilloscope's vertical input. A frequency standard (with long term stability greater than 1×10^{-10}) is connected to the trigger input. The time required for a specific phase change is measured immediately and after a period of time. The aging rate is inversely proportional to the absolute value of the difference in the measured times.

Equipment

Frequency Standard HP 5065A
 Oscilloscope HP 1980B

NOTE

Be sure the CW Generator has had 10 days to warm up before beginning this test. If the CW Generator was disconnected from the power line for less than 24 hours, only a 24 hour warm-up is needed.

Procedure

1. Set the rear panel FREQ REFERENCE INT-EXT switch to the INT position.
2. Connect the equipment as shown in Figure 4-13.

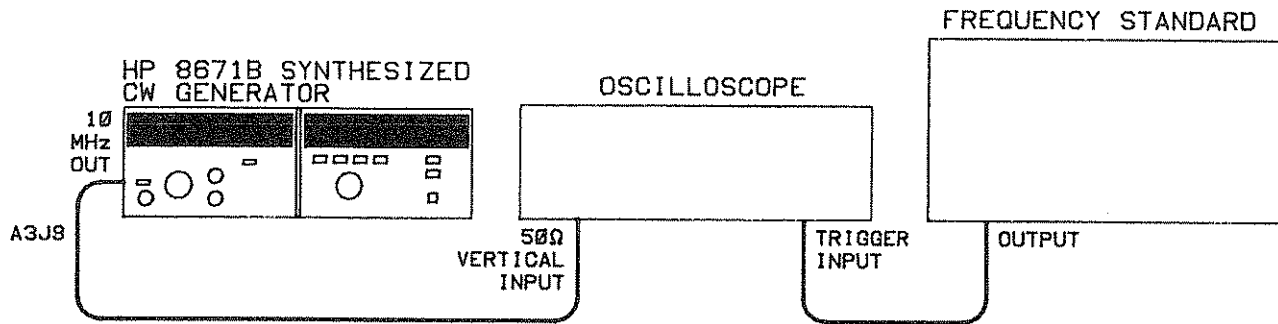

Figure 4-13. Internal Time Base Aging Rate Test Setup

3. Adjust the oscilloscope controls for a stable display of the 10 MHz CW Generator output.

PERFORMANCE TESTS

INTERNAL TIME BASE AGING RATE (cont'd)**Procedure
(cont'd)**

4. Measure the time required for a phase change of 360°. Record the time (T_1) in seconds.

$$T_1 = \text{_____ s}$$

5. Wait for a period of time (from 3 to 24 hours) and re-measure the phase change time. Record the period of time between measurements (T_2) in hours and the new phase change time (T_3) in seconds.

$$T_2 = \text{_____ h}$$

$$T_3 = \text{_____ s}$$

6. Calculate the aging rate from the following equation:

$$\text{Aging Rate} = \left| \left(\frac{1 \text{ cycle}}{f} \right) \left(\frac{1}{T_1} - \frac{1}{T_3} \right) \left(\frac{T}{T_2} \right) \right|$$

where: 1 cycle = the phase change reference for the time measurement (in this case, 360°)

f = CW Generator's reference output frequency (10 MHz)

T = specified time for aging rate (24h)

T_1 = initial time measurement(s) for a 360° (1 cycle) change

T_2 = time between measurements (h)

T_3 = final time measurement(s) for a 360° (1 cycle) change

for example:

$$\text{if } T_1 = 351\text{s}$$

$$T_2 = 3\text{h}$$

$$T_3 = 349\text{s}$$

then:

$$\begin{aligned} \text{Aging Rate} &= \left| \left(\frac{1 \text{ cycle}}{10 \text{ MHz}} \right) \left(\frac{1}{351\text{s}} - \frac{1}{349\text{s}} \right) \left(\frac{24\text{h}}{3\text{h}} \right) \right| \\ &= 1.306 \times 10^{-11} \end{aligned}$$

7. Verify that the aging rate is less than 5×10^{-10} .

NOTE

If the absolute frequencies of the frequency standard and the CW Generator's reference oscillator are extremely close, the measurement time in steps 5 and 6 (T_1 and T_3) can be reduced by measuring the time required for a phase change of something less than 360°. Change 1 cycle in the formula (i.e., 180° = 1/2 cycle, 90° = 1/4 cycle).

$$\text{Aging Rate} \text{ _____ } < 5 \times 10^{-10} / \text{day}$$

Table 4-4. Performance Test Record (1 of 6)

Hewlett-Packard Company Model 8671B Synthesized CW Generator Serial Number _____		Tested by _____ Date _____			
Para. No.	Test	Results			
		Min.	Actual	Max.	
4-7.	FREQUENCY RANGE AND RESOLUTION TEST				
	Baseband	3 000.000	2 999.999	_____	3 000.001
		2 000.000	1 999.999	_____	2 000.001
		2 000.001	2 000.000	_____	2 000.002
		2 001.112	2 001.111	_____	2 001.113
		2 002.223	2 002.222	_____	2 002.224
		2 003.334	2 003.333	_____	2 003.335
		2 004.445	2 004.444	_____	2 004.446
		2 005.556	2 005.555	_____	2 005.557
		2 006.667	2 006.666	_____	2 006.668
		2 007.778	2 007.777	_____	2 007.779
		2 008.889	2 008.888	_____	2 008.890
		2 009.999	2 009.998	_____	2 010.000
		2090.000	2089.999	_____	2090.001
		2 280.000	2 279.999	_____	2 280.001
		2 470.000	2 469.999	_____	2 470.001
		2 660.000	2 659.999	_____	2 660.001
		2 850.000	2 849.999	_____	2 850.001
		3 040.000	3 039.999	_____	3 040.001
		3 230.000	3 229.999	_____	3 230.001
		3 420.000	3 419.999	_____	3 420.001
		3 610.000	3 609.999	_____	3 610.001
		3 800.000	3 799.999	_____	3 800.001
		3 990.000	3 989.999	_____	3 990.001
		4 180.000	4 179.999	_____	4 180.001
		4 370.000	4 369.999	_____	4 370.001
		4 560.000	4 559.999	_____	4 560.001
		4 750.000	4 749.999	_____	4 750.001
		4 940.000	4 939.999	_____	4 940.001
		5 130.000	5 129.999	_____	5 130.001
		5 320.000	5 319.999	_____	5 320.001
		5 510.000	5 509.999	_____	5 510.001
		5 700.000	5 699.999	_____	5 700.001
		5 900.000	5 899.999	_____	5 900.001
		6 100.000	6 099.999	_____	6 100.001
		Bands 2 and 3	10 GHz, 2 kHz Resolution	_____	(✓)
			18 GHz, 3 kHz Resolution	_____	(✓)

Table 4-4. Performance Test Record (2 of 6)

Para. No.	Test	Results			
		Min.	Actual	Max.	
4-8.	FREQUENCY SWITCHING TIME TEST				
	Frequency Switching				
	18 GHz to 2.1 GHz		_____	15 ms	
	2.1 GHz to 18 GHz		_____	15 ms	
	Amplitude Recovery				
	2.1 to 6.1 GHz, 1 kHz resolution band		_____	15 ms	
	6.2 to 12.3 GHz, 2 kHz resolution band		_____	15 ms	
	12.4 to 18.0 GHz, 3 kHz resolution band		_____	15 ms	
4-9.	OUTPUT LEVEL, HIGH LEVEL ACCURACY AND FLATNESS TEST				
	Output Level				
	Frequency and Power at Minimum Power Point				
	2.0—18.0 GHz				
	Frequency _____				
	Minimum power	+8 dBm	_____		
	Level Flatness (total variation)				
	2.0—6.2 GHz		_____	1.50 dB	
	2.0—12.4 GHz		_____	2.00 dB	
	2.0—18.0 GHz		_____	2.50 dB	
	High Level Accuracy				
	+8 dBm (+10 dB range)	2 GHz	+6.25 dBm	_____	+ 9.75 dBm
		4 GHz	+6.25 dBm	_____	+ 9.75 dBm
		6 GHz	+6.25 dBm	_____	+ 9.75 dBm
		8 GHz	+6.00 dBm	_____	+10.00 dBm
		10 GHz	+6.00 dBm	_____	+10.00 dBm
		12 GHz	+6.00 dBm	_____	+10.00 dBm
		14 GHz	+5.75 dBm	_____	+10.25 dBm
		16 GHz	+5.75 dBm	_____	+10.25 dBm
		18 GHz	+5.75 dBm	_____	+10.25 dBm
	+3 dBm (+10 dB range)	2 GHz	+1.25 dBm	_____	+4.75 dBm
		4 GHz	+1.25 dBm	_____	+4.75 dBm
		6 GHz	+1.25 dBm	_____	+4.75 dBm
		8 GHz	+1.00 dBm	_____	+5.00 dBm
		10 GHz	+1.00 dBm	_____	+5.00 dBm
		12 GHz	+1.00 dBm	_____	+5.00 dBm
		14 GHz	+0.75 dBm	_____	+5.25 dBm
	16 GHz	+0.75 dBm	_____	+5.25 dBm	
	18 GHz	+0.75 dBm	_____	+5.25 dBm	
0 dBm (0 dB range)	2 GHz	-1.75 dBm	_____	+1.75 dBm	
	4 GHz	-1.75 dBm	_____	+1.75 dBm	
	6 GHz	-1.75 dBm	_____	+1.75 dBm	
	8 GHz	-2.00 dBm	_____	+2.00 dBm	

Table 4-4. Performance Test Record (3 of 6)

Para. No.	Test	Results			
		Min.	Actual	Max.	
4-9.	OUTPUT LEVEL, HIGH LEVEL ACCURACY AND FLATNESS TEST (cont'd)				
	High Level Accuracy (cont'd)				
	0 dBm (0 dB range) (cont'd)	10 GHz	-2.00 dBm	_____	+2.00 dBm
		12 GHz	-2.00 dBm	_____	+2.00 dBm
		14 GHz	-2.25 dBm	_____	+2.25 dBm
		16 GHz	-2.25 dBm	_____	+2.25 dBm
		18 GHz	-2.25 dBm	_____	+2.25 dBm
	-5 dBm (0 dB range)	2 GHz	-6.75 dBm	_____	-3.25 dBm
		4 GHz	-6.75 dBm	_____	-3.25 dBm
		6 GHz	-6.75 dBm	_____	-3.25 dBm
		8 GHz	-7.00 dBm	_____	-3.00 dBm
		10 GHz	-7.00 dBm	_____	-3.00 dBm
		12 GHz	-7.00 dBm	_____	-3.00 dBm
		14 GHz	-7.25 dBm	_____	-2.75 dBm
		16 GHz	-7.25 dBm	_____	-2.75 dBm
		18 GHz	-7.25 dBm	_____	-2.75 dBm
	-10 dBm (0 dB range)	2 GHz	-11.75 dBm	_____	-8.25 dBm
		4 GHz	-11.75 dBm	_____	-8.25 dBm
		6 GHz	-11.75 dBm	_____	-8.25 dBm
		8 GHz	-12.00 dBm	_____	-8.00 dBm
		10 GHz	-12.00 dBm	_____	-8.00 dBm
		12 GHz	-12.00 dBm	_____	-8.00 dBm
		14 GHz	-12.25 dBm	_____	-7.75 dBm
		16 GHz	-12.25 dBm	_____	-7.75 dBm
		18 GHz	-12.25 dBm	_____	-7.75 dBm
	-10 dBm (-10 dB range)	2 GHz	-12.25 dBm	_____	-7.75 dBm
		4 GHz	-12.25 dBm	_____	-7.75 dBm
		6 GHz	-12.25 dBm	_____	-7.75 dBm
		8 GHz	-12.50 dBm	_____	-7.50 dBm
		10 GHz	-12.50 dBm	_____	-7.50 dBm
		12 GHz	-12.50 dBm	_____	-7.50 dBm
		14 GHz	-12.85 dBm	_____	-7.15 dBm
		16 GHz	-12.85 dBm	_____	-7.15 dBm
		18 GHz	-12.85 dBm	_____	-7.15 dBm
	-20 dBm (-20 dB range)	2 GHz	-22.45 dBm	_____	-17.55 dBm
		4 GHz	-22.45 dBm	_____	-17.55 dBm
		6 GHz	-22.45 dBm	_____	-17.55 dBm
		8 GHz	-22.70 dBm	_____	-17.30 dBm
		10 GHz	-22.70 dBm	_____	-17.30 dBm
		12 GHz	-22.70 dBm	_____	-17.30 dBm
		14 GHz	-23.05 dBm	_____	-16.95 dBm
		16 GHz	-23.05 dBm	_____	-16.95 dBm
		18 GHz	-23.05 dBm	_____	-16.95 dBm

Table 4-4. Performance Test Record (4 of 6)

Para. No.	Test	Results		
		Min.	Actual	Max.
4-10.	LOW LEVEL ACCURACY			
	2.0 GHz			
	-30 dBm	-32.65 dBm	_____	-27.35 dBm
	-40 dBm	-42.95 dBm	_____	-37.05 dBm
	-50 dBm	-53.25 dBm	_____	-46.75 dBm
	-60 dBm	-63.55 dBm	_____	-56.45 dBm
	-70 dBm	-73.85 dBm	_____	-66.15 dBm
	-80 dBm	-84.15 dBm	_____	-75.85 dBm
	-90 dBm	-94.45 dBm	_____	-85.55 dBm
	-100 dBm	-104.75 dBm	_____	-95.25 dBm
	-110 dBm	-115.05 dBm	_____	-104.95 dBm
	10.0 GHz			
	-30 dBm	-32.90 dBm	_____	-27.10 dBm
	-40 dBm	-43.20 dBm	_____	-36.80 dBm
	-50 dBm	-53.50 dBm	_____	-46.50 dBm
	-60 dBm	-63.80 dBm	_____	-56.20 dBm
	-70 dBm	-74.10 dBm	_____	-65.90 dBm
	-80 dBm	-84.40 dBm	_____	-75.60 dBm
	-90 dBm	-94.70 dBm	_____	-85.30 dBm
	-100 dBm	-105.00 dBm	_____	-95.00 dBm
	-110 dBm	-105.30 dBm	_____	-104.70 dBm
	18.0 GHz			
	-30 dBm	-33.45 dBm	_____	-26.55 dBm
	-40 dBm	-43.85 dBm	_____	-36.15 dBm
	-50 dBm	-54.25 dBm	_____	-45.75 dBm
	-60 dBm	-64.65 dBm	_____	-55.35 dBm
	-70 dBm	-75.05 dBm	_____	-64.95 dBm
	-80 dBm	-85.45 dBm	_____	-74.55 dBm
	-90 dBm	-95.95 dBm	_____	-84.15 dBm
	-100 dBm	-106.35 dBm	_____	-93.75 dBm
-110 dBm	-107.75 dBm	_____	-103.35 dBm	
4-11.	OUTPUT LEVEL SWITCHING TIME			
	<20 ms		_____	
			20 ms	
4-12.	HARMONICS, SUBHARMONICS, AND MULTIPLES			
	Fundamental	Harmonic or Subharmonic		
	2.000000 GHz	4.000000 GHz 2f	_____	
	4.000000 GHz	8.000000 GHz 2f	_____	
	6.000000 GHz	12.000000 GHz 2f	_____	
			-25 dBc	
			-25 dBc	
			-25 dBc	

Table 4-4. Performance Test Record (5 of 6)

Para. No.	Test	Results		
		Min.	Actual	Max.
4-12.	HARMONICS, SUBHARMONICS, AND MULTIPLES (cont'd)			
		Harmonic or Subharmonic		
	Fundamental			
	8.000 000 GHz	16.000 000 GHz 2f	_____	-25 dBc
	8.000 000 GHz	4.000 000 GHz 1/2f	_____	-25 dBc
	10.000 000 GHz	20.000 000 GHz 2f	_____	-25 dBc
	10.000 000 GHz	5.000 000 GHz 1/2f	_____	-25 dBc
	11.000 000 GHz	22.000 000 GHz 2f	_____	-25 dBc
	11.000 000 GHz	5.500 000 GHz 1/2f	_____	-25 dBc
	14.000 000 GHz	4.666 667 GHz 1/3f	_____	-25 dBc
	14.000 000 GHz	9.333 333 GHz 2/3f	_____	-25 dBc
	16.000 000 GHz	5.333 333 GHz 1/3f	_____	-25 dBc
	16.000 000 GHz	10.666 667 GHz 2/3f	_____	-25 dBc
	18.000 000 GHz	6.000 000 GHz 1/3f	_____	-25 dBc
	18.000 000 GHz	12.000 000 GHz 2/3f	_____	-25 dBc
	4-13.	NON-HARMONICALLY RELATED SPURIOUS SIGNALS (CW AND AM MODES)		
Carrier Frequency		Spurious Signal Frequency	Spurious Signal Level	
2.0 to 6.2 GHz		_____	_____	-70 dBc
3 000 MHz		_____	_____	-70 dBc
_____		_____	_____	-70 dBc
_____		_____	_____	-70 dBc
_____		_____	_____	-70 dBc
4-14.	POWER LINE RELATED SPURIOUS SIGNALS			
		Offset Frequency		
	2.0-6.2 GHz			
	<300 Hz offset	_____	_____	-50 dBc
	300 Hz-1 kHz offset	_____	_____	-60 dBc
	>1 kHz offset	_____	_____	-65 dBc
	6.2-12.4 GHz			
	<300 Hz offset	_____	_____	-44 dBc
	300 Hz-1 kHz offset	_____	_____	-54 dBc
>1 kHz offset	_____	_____	-59 dBc	
12.4-18.0 GHz				
<300 Hz offset	_____	_____	-40 dBc	
300 Hz-1 kHz offset	_____	_____	-50 dBc	
>1 kHz offset	_____	_____	-55 dBc	

Table 4-4. Performance Test Record (6 of 6)

Para. No.	Test	Results				
		Min.	Actual	Max.		
4-14.	SINGLE-SIDEBAND PHASE NOISE	10 Hz offset from carrier	6100 MHz	_____	-58 dBc	
			12 200 MHz	_____	-52 dBc	
			18 000 MHz	_____	-48 dBc	
		100 Hz offset from carrier	6100 MHz	_____	-70 dBc	
			12 200 MHz	_____	-64 dBc	
			18 000 MHz	_____	-60 dBc	
		1 kHz offset from carrier	6100 MHz	_____	-78 dBc	
			12 200 MHz	_____	-72 dBc	
			18 000 MHz	_____	-68 dBc	
		10 kHz offset from carrier	6100 MHz	_____	-86 dBc	
			12 200 MHz	_____	-80 dBc	
			18 000 MHz	_____	-76 dBc	
		100 kHz offset from carrier	6100 MHz	_____	-110 dBc	
			12 200 MHz	_____	-104 dBc	
			18 000 MHz	_____	-100 dBc	
		4-15.	INTERNAL TIME BASE AGING RATE		_____	$5 \times 10^{-10}/\text{day}$



SECTION V ADJUSTMENTS

5-1. INTRODUCTION

This section contains adjustments and checks that assure peak performance of the CW Generator. This instrument should be readjusted after repair to assure performance. Allow a one hour warm-up prior to performing the adjustments. If the mains power cable is removed and reinstalled during an adjustment, be sure that the OVEN status annunciator is off before proceeding with the adjustment.

The order in which the adjustments are made is critical. Prior to making any adjustments, refer to the paragraph titled Related Adjustments.

Determining the adjustments to be performed after a component failure and subsequent repair or a performance test failure is important. This will help keep the adjustment time to a minimum. After the repair and/or adjustment, performance tests are usually required to verify proper performance. Refer to the paragraph titled Related Adjustments.

5-2. SAFETY CONSIDERATIONS

This section contains information, cautions and warnings which must be followed for your protection and to avoid damage to the equipment.

WARNINGS

Maintenance described in this section is performed with power supplied to the instrument and with protective covers removed. Maintenance should be performed only by service trained personnel who are aware of the hazard involved (for example, fire and electrical shock). Where maintenance can be performed without power applied, the power should be removed.

A pin-to-pin voltage difference of 60 Vdc may be found on many of the CW Generator's circuit board connectors. If a circuit board is placed on an extender board, the possibility of coming in contact with 60 Vdc is greatly increased. The voltage could cause personal injury if contacted.

5-3. EQUIPMENT REQUIRED

Each adjustment procedure contains a list of required test equipment and accessories. The test equipment is identified by callouts in the test setup diagrams included with each procedure.

If substitutions must be made for the specified test equipment, refer to Table 1-3 for the critical specifications. It is important that the test equipment meet the critical specifications listed in the table if the CW Generator is to meet its performance requirements.

The HP 11712A Support Kit is an accessory item available from Hewlett-Packard for use in servicing the CW Generator.

5-4. FACTORY SELECTED COMPONENTS

Factory selected components are identified on the schematics and parts list by an asterisk (*) that follows the reference designator. The nominal value of the component is shown. The manual change sheets will provide updated information pertaining to selected components. Table 5-1 lists the reference designator, the service sheet where the component is shown, the normal value range, and the criteria used for selecting a particular value.

5-5. RELATED ADJUSTMENTS

If all the adjustments are to be performed, they should be done in order of appearance in this manual.

In the event of a performance test or component failure, it must be determined if an individual adjustment procedure should be performed or if the instrument should be repaired. Tables 5-2 and 5-3 indicate the required action in either case.

After the instrument is repaired or adjusted, Performance Tests in Section IV must be performed to verify proper operation of the CW Generator. Tables 5-2 and 5-3 can also be used as a guideline when repairing or adjusting the instrument.

Table 5-1. Factory Selected Components

Reference Designator	Service Sheet	Range of Values	Basis of Selection
A3A1A2C8 and A3A1A2L4	2	0 to 12.0 pF 0.22 to .68 μ H	100 MHz VCXO Assembly. Centers the frequency adjustment range of A3A1A2C4 around 100 MHz. Refer to the 100 MHz VCXO Adjustment procedure.
A3A1A2R67, R68, and R69	2	Refer to Table in 100 MHz VCXO adjustment	100 MHz VCXO Assembly. Required change in attenuation necessary for a -10 dBm output level of the 400 MHz signal. Refer to the 100 MHz VCXO Adjustment procedure.
A3A1A5C38, R36, R40, and R41	5	R36: 82.5 or 56.2 Ω R41: 100 Ω or deleted R40: 51.1 Ω or C38 at 27 pF	M/N 5—45 MHz IF Output. If the power output from the IF OUT jack (A3A1A5J2) is less than -12 dBm at any frequency between 5 MHz to 45 MHz, replace R36 82.5 Ω with a 56.2 Ω resistor, R40 51.1 Ω with C38 27 pF capacitor, and remove R41. Proper power output level is between 0 and -12 dBm from 5 to 45 MHz. If this range cannot be met, service may be required.
A3A3R43	34	12 to 14.7 k Ω	Positive Regulator Assembly. Select so that pin 2 of V1 Power Up/Down Detector is 0.1 to 0.2V lower than the +5.2V Power Supply.
A3A9A5C10	11	20—22 pF	Sampler Assembly. Centers YTO phase detector sampler response. Refer to YTO Sampler Adjustment.
A3A9A5C2	11	120—150 pF	Selected for proper IF gain. Perform YTO Sampler Adjustment in this section.
A3A9A4R20	12	348 Ω to 1.21 k Ω	YTO Assembly. Sets YTO Phase-Locked Loop gain crossover to 20 \pm 2 kHz. Refer to the YTO Phase Detector Adjustment.

Table 5-2. Performance Test Failure and Required Action (1 of 2)

Performance Test Failure	Required Action	Repeat Performance Test(s)
Frequency Range and Resolution	Check phase-locked loops. See Service Sheets BD2, 3 and 4.	Frequency Range and Resolution.
Frequency Switching Time	Repair or adjust the phase-locked loop or the remote programming circuit boards A2A7 and A2A9.	Frequency Switching Time. Frequency Range and Resolution.
Output Level, High Level Accuracy and Flatness	Perform Flatness and ALC adjustment. Check output attenuator. See Service Sheets BD5 and BD6.	Output Level, High Level Accuracy and Flatness.
Low Level Accuracy	Check attenuator and level control assembly. See Service Sheets BD5 and BD6.	Low Level Accuracy, Output Level, High Level Accuracy and Flatness.

Table 5-2. Performance Test Failure and Required Action (2 of 2)

Performance Test Failure	Required Action	Repeat Performance Test(s)
Output Level Switching Time	Repair the level control assembly or replace the output attenuator.	Output Level Switching Time
Harmonics, Subharmonics, and Multiples	Perform YTM, ALC and Flatness adjustments. Check the YTM. See Service Sheet BD5.	Harmonics, Subharmonics, and Multiples. Output Level, High Level Accuracy and Flatness.
Non-Harmonically Related Spurious Signals	This problem can occur anywhere in the instrument. Isolate the defective component and make adjustments as required (see Table 5-3).	Non-Harmonically Related Spurious Signals.
Power Line Related Spurious Signals	Refer to Section VIII, Power Supply Schematics, Service Sheets 33—35.	Power Line Related Spurious Signals.
Single-Sideband Phase Noise	Check phase-locked loops. See Service Sheets BD2, 3, and 4.	Single-Sideband Phase Noise. Frequency Range and Resolution.
Internal Time Base Aging Rate	Replace A3A8 or repair power supply.	Internal Time Base Aging Rate.
NOTES		
<p>Some obscure performance failures (power level, phase noise, etc.) can be caused by failure of phase-locked loops. Therefore, Frequency Range and Resolution tests should be performed before troubleshooting other failures.</p> <p>If the output frequency is incorrect or any of the phase-lock loops are unlocked, make the appropriate adjustments and (if necessary) refer to Section VIII for repair information. After adjustment or repair, check for the correct frequency and verify that the phase-locked loops are locked. Perform the single-sideband phase noise test.</p>		

Table 5-3. Post-Repair Adjustments (1 of 2)

Repaired Assembly	Adjustments
A1AT1 Programmable Attenuator	ALC, Flatness, and External Leveling.
A1A3 YTM Assembly	YTM, Power Clamp, ALC, Flatness, and External Leveling.
A1A5, A6, A7, A8 YTM and ALC Circuits	YTM, ALC, Flatness, and External Leveling.
A1A6 External Leveling Circuits Only	External Leveling
A1A12 Power Amplifier	YTM, ALC, Flatness, and External Leveling.
A1DC1 — Directional Coupler	Flatness and ALC

Table 5-3. Post-Repair Adjustments (2 of 2)

Repaired Assembly	Adjustments
A2A3, A2A4, A2A5 — LFS Phase-Locked Loop Circuits	20/30 MHz Divider Bias 160—140 MHz VCO Pretune 20/30 Phase Detector Notch Filter
A3A2, A3A3, A3A4 — Power Supplies	Power Supply
A3A1A1, A3A1A2 — Time Base Reference	100 MHz VCXO
A3A1A3, A3A1A4, A3A1A5 — M/N Phase-Locked Loop Circuits.	M/N VCO
A3A5 — DAC Assembly A3A6 — YTO Driver Assembly	YTO Pretune Digital-to-Analog Converter YTO Driver YTO Sampler YTO Phase Detector
A3A7 — YTO HF Coil Driver Assembly	YTO Pretune Digital-to-Analog Converter YTO Driver YTO Sampler YTO Phase Detector
A3A9A3 — 2.0 to 6.2 GHz YTO Assembly	YTO Pretune Digital-to-Analog Converter YTO Driver YTO Sampler YTO Phase Detector

ADJUSTMENTS

5-6. POWER SUPPLY ADJUSTMENTS

- Reference** Service Sheets 33—35.
- Description** This procedure adjusts the +22 volt and +20 volt power supplies to their required tolerance. The remaining supply voltages (+11V, +5.2V, -5.2V, -10V, and -40V) are checked.
- Equipment** Digital Voltmeter (DVM) HP 3456A
- Procedure**
1. Set the CW Generator's rear panel **FREQ STANDARD INT/EXT** switch to **INT**.
 2. Connect the DVM input to **A3A2TP1** on the Rectifier Assembly.
 3. Adjust **+22 ADJ (A3A2R2)** for a DVM reading of $+22.00 \pm 0.02$ Vdc.
 4. Connect the DVM input to **A3A3TP5** on the Positive Regulator Assembly.
 5. Set **+20 ADJ (A3A3R50)** for a DVM reading of $+20.000 \pm 0.002$ Vdc.
 6. Check the power supplies shown in the following table. All voltages should be within tolerance.

Power Supply	Test Point	Power Supply Voltage (Vdc)	
		Min.	Max.
+11 Vdc	A3A3TP6	+9.9	+12.1
+5.2 Vdc	A3A3TP2	+5.1	+5.3
-5.2 Vdc	A3A4TP5	-5.1	-5.3
-10 Vdc	A3A4TP4	-9.8	-10.2
-40 Vdc	A3A4TP1	-39.00	-40.60

ADJUSTMENTS

5-7. 10 MHz REFERENCE OSCILLATOR ADJUSTMENT

Reference Service Sheet 1.

Description This procedure adjusts the frequency of the internal reference oscillator using an external frequency standard.

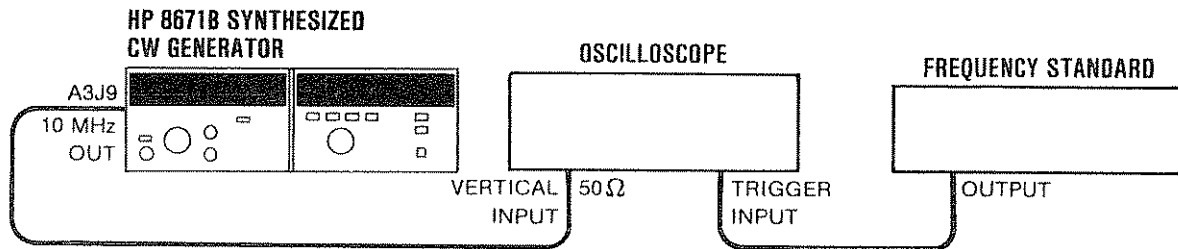

Figure 5-1. 10 MHz Reference Oscillator Adjustment Test Setup

Equipment

Frequency Standard	HP 5065A
Oscilloscope	HP 1980B

NOTE

Frequency drift is greatest when the instrument power cable is first connected. Therefore, for best long-term accuracy, the power cord should be connected for at least 30 days before making this adjustment.

Be sure the CW Generator has had one hour to warm up before performing the adjustment. Verify that the OVEN and NOT PHASE LOCKED status annunciators are off. If necessary, refer to the troubleshooting information in Section VIII.

- Procedure**
1. Set the CW Generator's rear panel FREQ STANDARD INT/EXT switch to the INT position.
 2. Connect the equipment as shown in Figure 5-1. Set the vertical input of the oscilloscope for 50Ω input impedance.
 3. Set the FREQ adjustment (on the A3A8 10 MHz Reference Oscillator Assembly) so the signal, as observed on the oscilloscope display, is not drifting.
 4. Verify that in 10 seconds the display drifts less than 360°. A drift of 360° in 10 seconds corresponds to an adjustment accuracy of 1×10^{-8} . Adjustment accuracy is not specified for this instrument; the numbers shown are what can typically be obtained.

ADJUSTMENTS

5-8. 100 MHz VCXO ADJUSTMENT

Reference Service Sheet 2.

Description The frequency and tuning range output of the 100 MHz Voltage Controlled Crystal Oscillator (VCXO) is centered around 100 MHz. The output is set as close as practical to 100 MHz. The 400 MHz multiplied signal is adjusted for maximum output and minimum spurious signal output. An attenuator is selected to provide a 400 MHz output of -10 dBm.

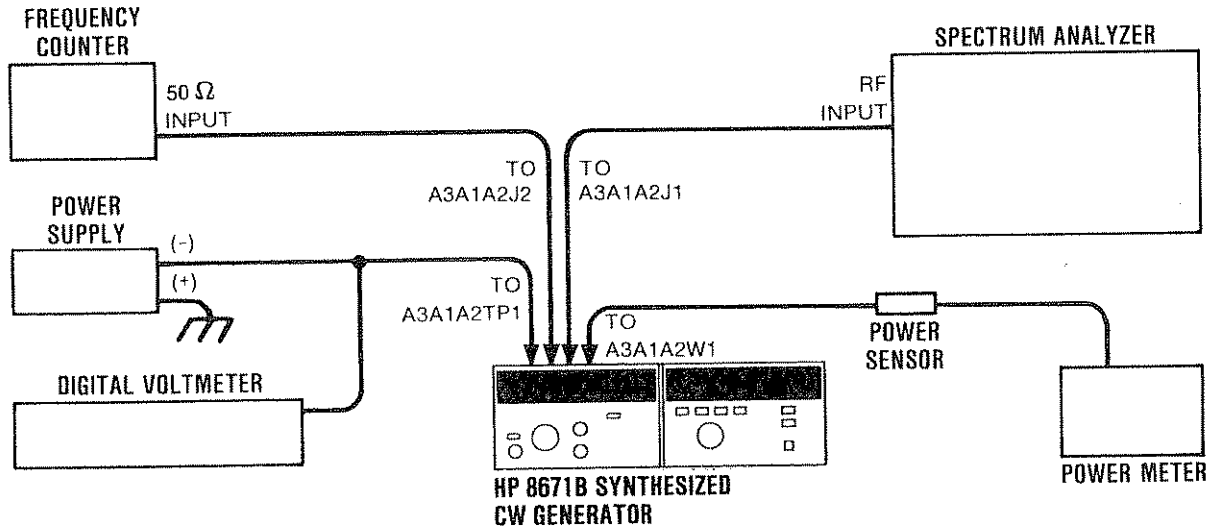

Figure 5-2. 100 MHz VCXO Adjustment Test Setup

Equipment	Frequency Counter	HP 5343A
	Spectrum Analyzer	HP 8566B
	Power Supply	HP 6200B
	Power Meter	HP 436A
	Power Sensor	HP 8481A
	Digital Voltmeter (DVM)	HP 3456A

- Procedure**
1. Connect the frequency counter to A3A1A2J2 in place of the termination and connect the spectrum analyzer to A3A1A2J1 in place of the gray-orange-white cable, as shown in Figure 5-2.
 2. Set the output of the power supply to -8.00 ± 0.01 Vdc. Connect the positive lead to ground and the negative lead to A3A1A2TP1, 100 MHz TUNE.
 3. Tune A3A1A2C4, 100 MHz, for the maximum 100 MHz signal level as viewed on the spectrum analyzer display.
 4. Tune A3A1A2C4 to increase the frequency (and decrease the amplitude) until the oscillation stops on the high frequency side; then tune A3A1A2C4 to start the oscillation. Continue to decrease the frequency until the oscillation stops. If the VCXO does not stop oscillating at the high end, decrease the value of A3A1A2C8 by 1 pF from its present value. If it does not stop at the low end, increase the value of A3A1A2C8 by 1 pF. If a change is necessary, repeat this step. If a value of

ADJUSTMENTS

5-8. 100 MHz VCXO ADJUSTMENT (cont'd)**Procedure
(cont'd)**

A3A1A2C8 cannot be found within the range of 0 to 12 pF, change A3A1A2L4 (the range of values for A3A1A2L4 is listed in step 7), then repeat this step.

5. Adjust A3A1A2C4 to obtain the maximum signal level as viewed on the spectrum analyzer display. Slowly tune to a higher frequency until the power drops by 1 dB. Record ΔF_1 , that is, how far the frequency of the 1 dB point is above 100 MHz. Use the frequency counter to make the measurement to 10 Hz resolution.

_____ ΔF_1

6. Tune to a lower frequency until the power is decreased 1 dB on the other side of the peak. Record ΔF_2 , that is, how far the frequency of the 1 dB point is below 100 MHz.

_____ ΔF_2

7. The VCXO centering about 100 MHz is correct if $0.5 \leq \frac{\Delta F_1}{\Delta F_2} \leq 2$.

If the ratio is less than 0.5, decrease A3A1A2L4 one value to increase the center frequency. If the ratio is greater than 2, increase A3A1A2L4 one value to decrease the center frequency. Refer to the following table for the inductor values.

A3A1A2L4 Inductor Values

Value	HP Part Number
0.68 μH	9140-0141
0.56 μH	9100-2256
0.47 μH	9100-2255
0.39 μH	9100-2254
0.33 μH	9100-0368
0.27 μH	9100-2252
0.22 μH	9100-2251

8. If the inductor value is changed, repeat steps 3 through 7.
9. Adjust A3A1A2C4 to obtain a VCXO output of 100 MHz \pm 100 Hz.
10. Disconnect the spectrum analyzer from A3A1A2J1 and reconnect the gray-orange-white cable.
11. Disconnect the 400 MHz Output cable (gray-red-white cable) from A3A1A5J1 and connect the cable to the spectrum analyzer. Set the spectrum analyzer's controls for a center frequency of 500 MHz, frequency span per division 100 MHz, and vertical sensitivity per division 10 dB log. Adjust the 400 MHz A3A1A2C3, C2, and C1 adjustments in that order to obtain the maximum 400 MHz signal with the lowest harmonic levels possible.
-

ADJUSTMENTS

5-8. 100 MHz VCXO ADJUSTMENT (cont'd)**Procedure
(cont'd)**

12. Check the various harmonics of the 100 MHz signal relative to the 400 MHz signal level. The 200 and 800 MHz harmonics should be greater than 25 dB down; 100, 300, 500, 600, 700, and 900 MHz harmonics should be greater than 35 dB down. If necessary, repeat steps 11 and 12.
13. Disconnect the spectrum analyzer from the gray-red-white cable and connect the cable to the power meter.
14. Check the power meter reading. The power should be -10 to -13 dBm. If the power is incorrect, select the values of A3A1A2R67, R68, and R69 from the Attenuator Resistor Values Table to obtain the proper power level. The attenuation should always be 3 dB or greater.

Attenuator Resistor Values

Attenuation (dB)	Resistors (ohms)		
	R67	R68	R69
3	261	17.8	261
4	215	23.7	215
5	178	31.6	178
6	147	38.3	147
7	133	46.4	133
8	121	51.1	121
9	110	61.9	110

15. If the amount of attenuation is changed, recheck the harmonic levels.
 16. Set the CW Generator's LINE switch to STANDBY. Disconnect all test equipment except the DVM and reconnect all instrument cables.
 17. Set the CW Generator's LINE switch to ON. Verify that the dc voltage at A3A1A2TP1 is -8 ± 1 Vdc. If the voltage is out of tolerance, repeat step 9 or check the 10 MHz Reference Adjustment.
 18. Connect the frequency counter to the CW Generator's RF OUTPUT connector.
 19. Verify that the counter reading is within ± 1 kHz of the CW Generator's FREQUENCY MHz display at 2000 and 6199 MHz.
-

ADJUSTMENTS

5-9. M/N VCO ADJUSTMENT

Reference Service Sheet 4.

Description The M/N Phase-Locked Loop frequency is set to track the VCO tuning voltage across the frequency range. The M/N VCO output level is set and checked to ensure an adequate RF output level across the VCO tuning range.

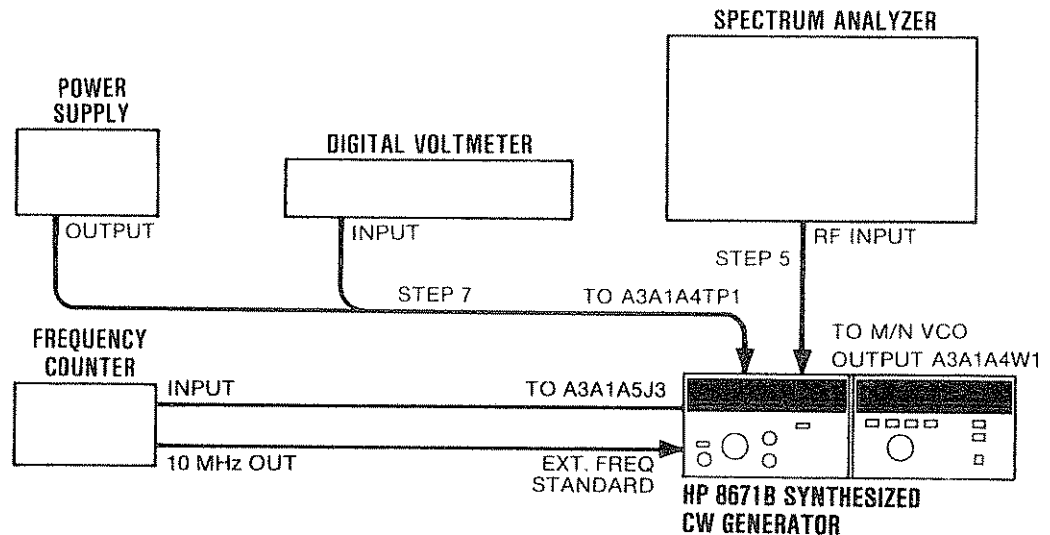

Figure 5-3. M/N VCO Adjustment Test Setup

Equipment	Digital Voltmeter (DVM)	HP 3456A
	Frequency Counter	HP 5343A
	Spectrum Analyzer	HP 8566B
	Power Supply	HP 6200B

- Procedure**
1. On the CW Generator, press PRESET (3 GHz) and set the frequency to 6090.000 MHz. Set the FREQ STANDARD INT/EXT on the rear panel to EXT.
 2. Connect the equipment as shown in Figure 5-3.
 3. Verify that the M/N output frequency is 197.419 MHz \pm 1 kHz.

WARNING

Because this circuit board is being placed on an extender board, the possibility of coming in contact with 60 Vdc is greatly increased. The voltage could cause personal injury if contacted.

4. Set the LINE switch to STANDBY and disconnect the mains power cable. Remove the A3A1A4/A5 Assembly and place it on an extender board.
5. Connect the spectrum analyzer input to the M/N VCO output A3A1A4W1 (white coax).

ADJUSTMENTS

5-9. M/N VCO ADJUSTMENT (cont'd)**Procedure
(cont'd)**

CAUTION

Do not apply a positive voltage to A3A1A4TP1. A positive voltage will forward bias the VCO tuning diodes and may destroy them.

6. Connect the mains power cable and set the LINE switch to ON.
7. Set the power supply for -35.0 ± 0.5 Vdc. Connect the positive output of the power supply to ground and connect the negative output to A3A1A4TP1 TUNE.
8. Release the locknut for the PWR adjustment, A3A1A4A1C5. Adjust A3A1A4A1C5 for an output level of 0 ± 2 dBm. Tighten the locknut.

NOTE

The adjustment screws for A3A1A4A1C1 and C5 are held in place by locknuts. After making the adjustment, tighten the locknuts and recheck the frequency and level.

9. Slowly reduce the dc voltage at A3A1A4TP1, TUNE, while monitoring the VCO output power on the spectrum analyzer. The output power should be greater than -2 dBm between 395 MHz (-35 Vdc) and 355 MHz (-2.3 Vdc).
 10. Reconnect A3A1A4W1 (white coax) to A3A1A5J4.
 11. Connect the spectrum analyzer to A3A1A5J2 and adjust it for a center frequency of 50 MHz.
 12. Slowly adjust the dc voltage at A3A1A4TP1, TUNE, while monitoring the VCO output power on the spectrum analyzer. The output power should be -6 ± 6 dBm between 5 MHz (-35 Vdc) and 45 MHz (-2.3 Vdc).
 13. If the output power is greater than 0 dBm, service may be required. If the output power is less than -12 dBm at any frequency between 5 MHz and 45 MHz, replace R36 (82.5 ohms) with a 56.2 ohm resistor, R40 (51.1 ohms) with C38 (27 pF capacitor), and remove R41.
 14. If component replacement is necessary, repeat step 12 after repairs have been made. If the power output is still less than -12 dBm at any frequency between 5 MHz and 45 MHz, service is required. Refer to the troubleshooting procedure in Service Sheet 4, Section VIII.
 15. Remove the power supply connection to A3A1A4TP1.
 16. Set the LINE switch to STANDBY and disconnect the mains power cable. Remove A3A1A4/A5 from the extender board and reinstall the assembly in the CW Generator.
 17. Connect the mains power cable and set the LINE switch to ON. Verify that the frequency is still at 6090.000 MHz.
-

ADJUSTMENTS

5-9. M/N VCO ADJUSTMENT (cont'd)**Procedure
(cont'd)**

18. Set **FREQ ADJ A3A1A4A1C1** for a voltage level of -35.0 ± 0.5 Vdc, measured at **A3A1A4TP1**.
19. Tune the CW Generator frequency to 2100.000 MHz. Verify that the M/N output frequency is 177.500 MHz and the tuning voltage is -2.4 ± 0.7 Vdc.
20. Disconnect all test equipment from the CW Generator and reconnect all internal instrument cables.
21. Connect the frequency counter to the CW Generator's **RF OUTPUT** connector.
22. Verify that the counter reading is within ± 1 kHz of the CW Generator's **FREQUENCY MHz** display at 2000 and 6199 MHz.

ADJUSTMENTS

5-10. 20/30 DIVIDER BIAS ADJUSTMENT

Reference Service Sheet 6.

Description A substitute VCO feedback signal, derived from an external RF signal source, is monitored with an oscilloscope. The RF signal level is slowly reduced and the CLK BIAS ADJ is set to obtain a stable clock signal. The RF input is reduced to the minimum level that provides a stable signal.

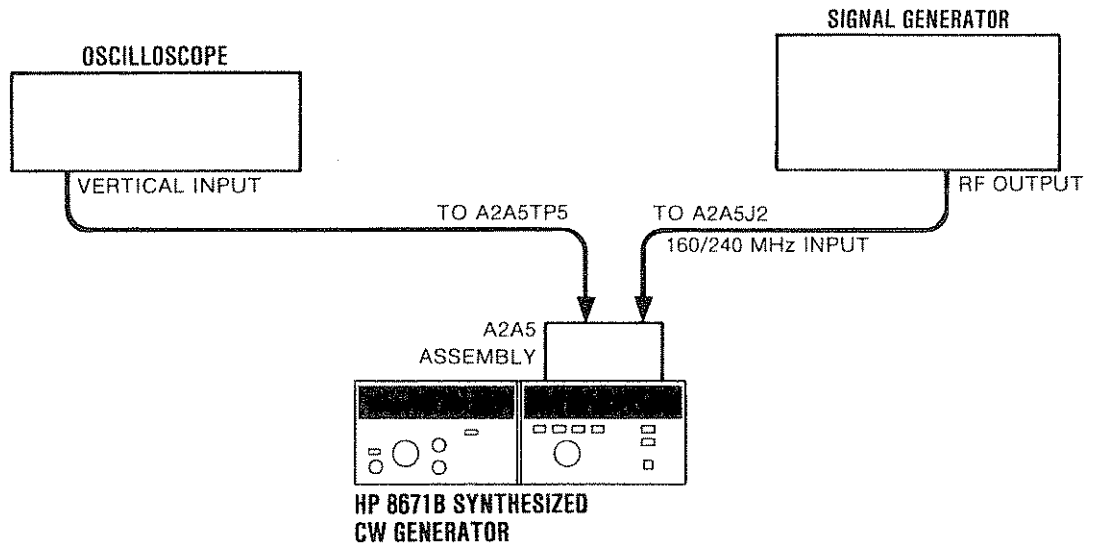

Figure 5-4. 20/30 Divider Bias Adjustment Test Setup

Equipment Oscilloscope HP 1980B
 Signal Generator HP 8640B or 8340A

- Procedure**
1. Set the LINE switch to STANDBY and remove the mains power cable.
 2. Remove the screws that hold the A2A5 20/30 MHz Divider Assembly in place.

WARNING

Because this circuit board is being placed on an extender board, the possibility of coming in contact with 60 Vdc is greatly increased. The voltage could cause personal injury if contacted.

3. Remove the A2A5 Assembly, place it on an extender board, and reinstall the assembly.
4. Reconnect the mains power cable and set the LINE switch to ON.
5. Set the controls of the signal generator for continuous wave output of -5 dBm at 240 MHz.

ADJUSTMENTS

5-10. 20/30 MHz DIVIDER BIAS ADJUSTMENT (cont'd)**Procedure
(cont'd)**

6. Remove the red cable A2W2 from the 160/240 MHz INPUT, A2A5J1.
7. Connect the equipment as shown in Figure 5-4.
8. Center A2A5R4 (CLK BIAS ADJ).
9. Observe the 14–24 MHz clock signal on the oscilloscope display.
10. Adjust A2A5R4 to obtain a stable clock frequency on the oscilloscope display.
11. Reduce the output level of the signal generator while readjusting A2A5R4 to obtain a stable clock at the lowest possible local oscillator signal display.
12. Verify that a stable clock signal is obtained with an input signal of –10 dBm or less.
13. Disconnect the test equipment. Set the CW Generator to STANDBY and disconnect the mains power cable. Reinstall A2A5 in its cavity. Reconnect cable A2W2 to A2A5J1 and reconnect the mains power cable.

ADJUSTMENTS

5-11. 160—240 MHz VCO PRETUNE ADJUSTMENT

Reference Service Sheet 8.

Description This procedure sets the low and high frequency limits of the 160—240 MHz oscillator by moving the oscillator coil closer to or farther from the circuit board.

NOTE

This procedure need be performed only if major repair has been done to the 160—240 MHz oscillator.

Equipment Frequency Counter HP 5343A

- Procedure**
1. Set the LINE switch to STANDBY and remove the mains power cable.
 2. Remove the screws that hold the A2A3 VCO assembly in place.

WARNING

Because this circuit board is being placed on an extender board, the possibility of coming in contact with 60 Vdc is greatly increased. The voltage could cause personal injury if contacted.

3. Remove the A2A3 assembly, place it on an extender board, and reinstall the assembly.
4. Remove the green cable A3W14 that is connected to the 20/30 MHz OUTPUT A2A3J1. Connect the frequency counter to A2A3J1.
5. Reconnect the mains power cable and set the LINE switch to ON.
6. Set A2A3S1 (FREQ TEST SWITCH) to the TEST HIGH FREQ position. The frequency should be greater than 30.5 MHz.
7. If the frequency is less than 30.4 MHz, move the oscillator coil closer to the circuit board. The oscillator cover must be removed before adjusting the coil. Unsolder the four corners of the oscillator cover before removing it. Next, unsolder the oscillator coil leads, move the coil closer to the circuit board, and resolder the coil leads. Clip excess oscillator lead length on the circuit side of board if necessary.

NOTE

The oscillator coil is normally mounted parallel to the circuit board with the bottom threads approximately 1.3 mm (0.050 inch) above the board.

8. Replace the oscillator cover by temporarily soldering one corner of the cover and recheck the frequency.

ADJUSTMENTS

5-11. 160—240 MHz VCO PRETUNE ADJUSTMENT (cont'd)**Procedure
(cont'd)**

9. Set A2A3S1 to the TEST LOW FREQ position. Verify a frequency reading of less than 19.5 MHz. If necessary, set the LINE switch to STANDBY, remove the cover, reset the coil, replace the cover, and repeat steps 6 through 9.
10. Set A2A3S1 to the NORMAL position.
11. Replace the oscillator cover permanently by soldering all four corners. Do not solder the entire perimeter of the oscillator cover. The cover is for frequency stability, not for RFI leakage.
12. Set the LINE switch to STANDBY and remove the mains power cable. Reinstall A2A3 in its cavity and reconnect the green cable to A2A3J1. Reconnect the mains power cable.

ADJUSTMENTS

5-12. 20/30 PHASE DETECTOR NOTCH FILTER ADJUSTMENT

Reference Service Sheet 7.

Description A 7985 Hz signal is passed through the 8 kHz notch filter in the LFS Phase-Locked Loop. The adjustable components of the filter are set for the minimum signal transfer.

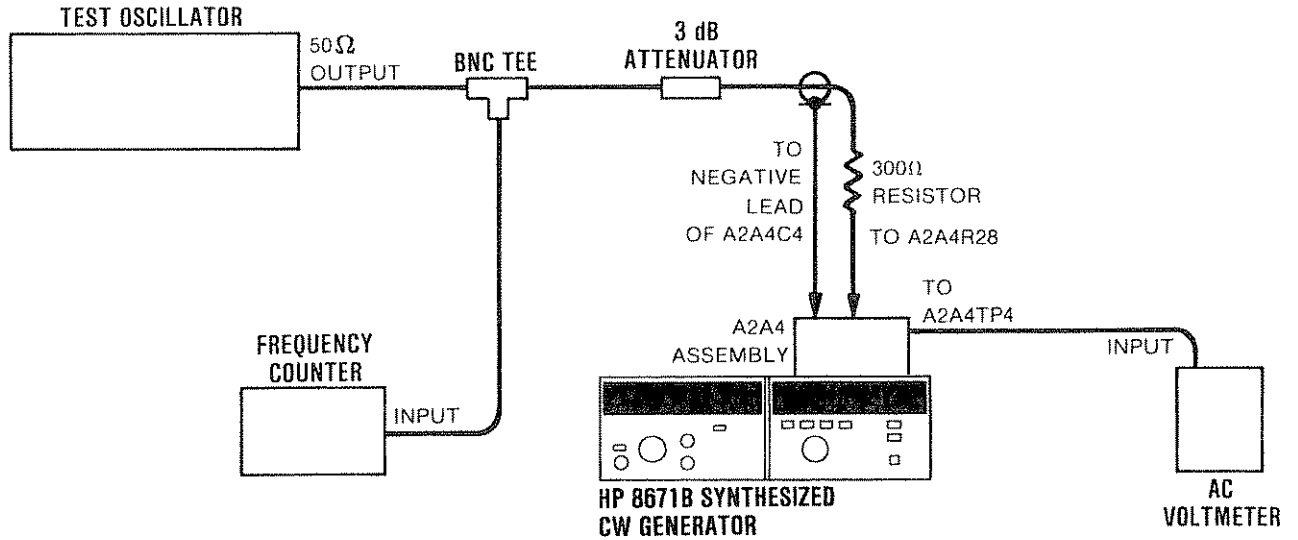

Figure 5-5. 20/30 Phase Detector Notch Filter Adjustment Test Setup

Equipment	Test Oscillator	HP 8116A
	Frequency Counter	HP 5343A
	AC Voltmeter	HP 400E
	3 dB Attenuator	HP 8491A Option 003

Procedure 1. Set the LINE switch to STANDBY.

WARNING

Because this circuit board is being placed on an extender board, the possibility of coming in contact with 60 Vdc is greatly increased. The voltage could cause personal injury if contacted.

2. Remove the A2A4 20/30 Phase Detector Assembly.
3. Unsolder the input end (top) of A2A4R28 (refer to the component location diagram in Section VIII).
4. Install the circuit board on the extender board.

ADJUSTMENTS

5-12. 20/30 PHASE DETECTOR NOTCH FILTER ADJUSTMENT (cont'd)**Procedure
(cont'd)**

5. Connect the equipment as shown in Figure 5-5. The leads from the 3 dB attenuator should be as short as possible. Connect the ground wire to the negative side of A2A4C4.
6. Set the CW Generator's LINE switch to ON.
7. Set the test oscillator's controls for 1 kHz and an AC voltmeter indication of +10 dBm.
8. Set the test oscillator as close to 7985 Hz as possible.
9. Adjust A2A4L3 and L4 to minimize the meter reading. The indication must be less than -50 dBm.
10. Detune the test oscillator away from 7985 Hz while monitoring the AC voltmeter reading. As the oscillator is detuned, the meter indication should increase.
11. Set the CW Generator's LINE switch to STANDBY. Resolder A2A4R28 and reinstall the A2A4 assembly.

ADJUSTMENTS

5-13. YTO PRETUNE DIGITAL-TO-ANALOG CONVERTER ADJUSTMENT

Reference	Service Sheet 9.
Description	This adjustment sets the analog voltages with respect to the digital frequency tuning data. Adjustments are made at selected frequencies. Some of these frequencies are below the low frequency limit of the CW Generator (2 GHz). These frequencies are selected by shorting test point pair A2A8TP1 and tuning to the specified frequencies.
Equipment	Digital Voltmeter (DVM) HP 3456A or HP 3455A
Procedure	<ol style="list-style-type: none"> 1. Press PRESET (3 GHz) on the CW Generator and set the frequency to 4800.000 MHz. 2. Connect the DVM ground lead to the reference ground, A3A6TP5 (the ground lead remains connected here for the remainder of this procedure). 3. Attach the DVM test lead to A3A5TP4. Set REF ADJ (Reference Buffer output) A3A5R13 for a DVM reading of -6.50 ± 0.04 Vdc. 4. Check the output voltages of the Reference Buffers at A3A5TP1 ($+10.75 \pm 0.25$ Vdc) and A3A5TP2 ($+10.00 \pm 0.15$ Vdc). Make repairs if necessary. 5. Connect the DVM to the YTO Pretune Output, A3A5TP3. 6. Short test point pair A2A8TP1 with an alligator clip. 7. Adjust 1.6 GHz A3A5R4 (not 1.61) to obtain a DVM reading of -4.800 ± 0.001 Vdc. 8. Remove the clip from test point pair A2A8TP1. 9. Adjust 4.8 GHz A3A5R3 to obtain a reading of -14.400 ± 0.001 Vdc. 10. Tune to 4900.000 MHz and short the test point pair A2A8TP1. 11. Adjust 1.7 GHz A3A5R29 to obtain -5.100 ± 0.001 Vdc. 12. Tune to 4800.000 MHz and repeat steps 7 through 11 until all voltages are measured within 0.001 Vdc of the specified value. 13. Tune to 4810.000 MHz. Verify that the clip is connected to test point pair A2A8TP1. 14. Adjust 1.61 GHz A3A5R42 (not 1.6) to obtain a DVM reading of -4.830 ± 0.001 Vdc. 15. Tune to 5000.000 MHz. Adjust 1.8 GHz A3A5R24 to obtain -5.400 ± 0.001 Vdc. 16. Remove the alligator clip. Tune to 2000.000 MHz. 17. Adjust 2.0 GHz A3A5R22 to obtain -6.000 ± 0.001 Vdc. 18. Tune to 2400.000 MHz. Adjust 2.4 GHz A3A5R20 to obtain -7.200 ± 0.001 Vdc.

ADJUSTMENTS

5-13. YTO PRETUNE DIGITAL-TO-ANALOG CONVERTER ADJUSTMENT (cont'd)**Procedure
(cont'd)**

19. Tune to 3200.000 MHz. Adjust 3.2 GHz A3A5R18 to obtain -9.600 ± 0.001 Vdc.
20. At each frequency listed in the table, check the YTO pretune voltage at A3A5TP3 with the clip attached to the test point pair A2A8TP1.

CW Generator Frequency (MHz)	Voltage at A3A5TP3 (Vdc)
4801	-4.803 ± 0.001
4802	-4.806 ± 0.001
4804	-4.812 ± 0.001
4808	-4.824 ± 0.001
4810	-4.830 ± 0.001
4820	-4.860 ± 0.001
4840	-4.920 ± 0.001
4880	-5.040 ± 0.001
4910	-5.130 ± 0.001

21. Remove the clip and measure the voltage at A3A5TP3. The voltage should now read -14.730 ± 0.002 Vdc. If the voltage tolerances in steps 21 and 22 are not met, repeat this procedure starting from step 5. Then if the voltage tolerances cannot be met, refer to Section VIII for troubleshooting information.

ADJUSTMENTS

5-14. YTO DRIVER ADJUSTMENT

Reference	Service Sheet 10.
Description	The fundamental output of the CW Generator is set to the maximum and minimum frequencies and the YTO driver's gain and offset currents are set to give specified YTO output frequencies.
Equipment	Frequency Counter HP 5343A

NOTE

All boards must be installed in the instrument before these adjustments are made.

Procedure	<ol style="list-style-type: none"> 1. On the CW Generator, press PRESET (3 GHz) and set the output level to -10 dBm. 2. Connect the frequency counter to the CW Generator's RF OUTPUT connector. 3. Connect A3A6TP5 (GND) to A3A7TP2 (TUN VOLT) with a clip-on jumper wire. (This grounds the feedback voltage and opens the YTO Phase-Locked Loop.) 4. Tune the CW Generator to 2000.000 MHz. Adjust A3A6R34, 2 GHz, to obtain 2000.0 \pm0.1 MHz on the frequency counter. Wait until the drift is minimal (approximately 30 seconds) before making this adjustment. 5. Tune the CW Generator to 6199.000 MHz. Adjust A3A6R25, which is labeled 6.199 GHz, to obtain 6199.0 \pm0.1 MHz on the frequency counter. Wait until the drift is minimal (approximately 30 seconds) before making this adjustment. 6. Repeat steps 4 and 5 until the required tolerance is obtained at both frequencies. 7. Disconnect A3A6TP5 from A3A7TP2. 8. Verify that the counter reading is within \pm1 kHz of the CW Generator's FREQUENCY MHz display at 2.0 and 6.199 GHz.
------------------	--

ADJUSTMENTS

5-15. YTO SAMPLER ADJUSTMENT

Reference Service Sheet 11.
Service Sheet A.

Description The sampler is driven by a sweep oscillator and the sweep output is used to sweep the oscilloscope. The sampler driver circuit is adjusted for maximum amplitude and flatness over the range of the M/N loop. The sampler's IF preamplifier is adjusted for correct level and the frequency response is checked.

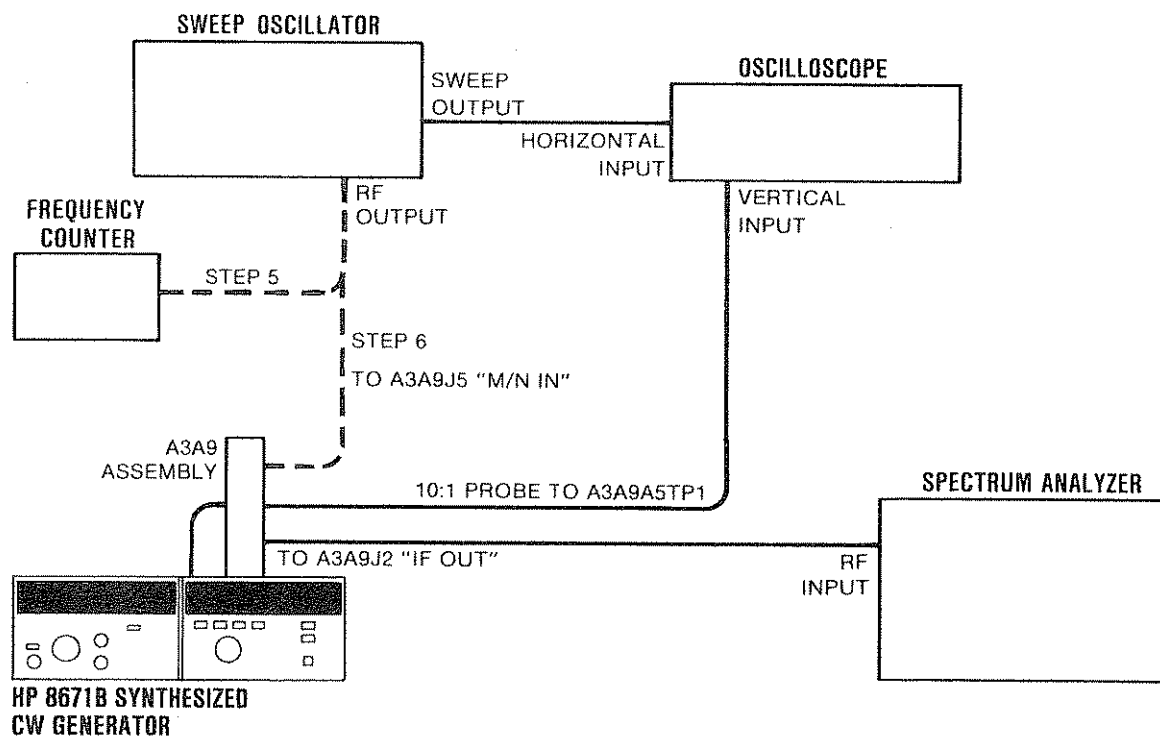

Figure 5-6. YTO Loop Sampler Adjustment Test Setup

Equipment	Oscilloscope	HP 1980B
	Sweep Oscillator	HP 86222B/8620C or HP 8340A
	Spectrum Analyzer	HP 8566B
	Frequency Counter	HP 5343A
	50Ω Termination	HP 909A Opt 012

NOTE

An HP 8481A Power Sensor can be used in place of the 50Ω termination.

ADJUSTMENTS

5-15. YTO SAMPLER ADJUSTMENT (cont'd)

Procedure (cont'd)

1. Set the CW Generator's LINE switch to STANDBY and disconnect the mains power cable.
2. Place the A3A9 Assembly into the service position (refer to Service Sheet A for disassembly procedures).
3. Remove the right side cover of A3A9.
4. Connect a 50Ω termination to the A3A9A1 Directional Coupler output, which normally connects to A1W1.
5. Set the sweep oscillator's controls for a leveled output level of 0 dBm, center frequency of 187.5 ± 1.0 MHz (measured by frequency counter) and a sweep span of 200 MHz (± 100 MHz).
6. Connect the equipment as shown in Figure 5-6. Connect the CW Generator's mains power cord and set the LINE switch to ON.
7. Connect the sweep oscillator's RF output to the M/N LOOP SIGNAL connector, A3A9J5, in place of the white-orange cable.
8. Adjust A3A9A5C1 and C2 (with an insulated adjustment tool) to get an oscilloscope display similar to Figure 5-7. Tune for maximum negative voltage and flatness over the center two divisions. The minimum change from the reference level to the maximum negative voltage should be 0.5 volts. (Troubleshooting Note: If the minimum change is out of tolerance, A3A9A5Q3 and Q8 may have low gain, the YTO feedback signal feeding the RF port of the mixer may be low, or the sampler may be bad.)

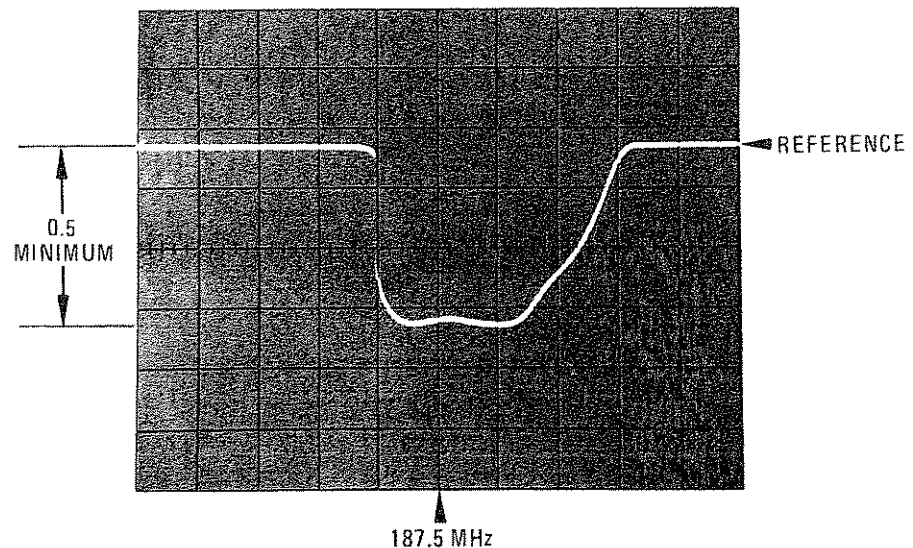

Figure 5-7. YTO Sampler Frequency Response

ADJUSTMENTS

5-15. YTO SAMPLER ADJUSTMENT (cont'd)**Procedure
(cont'd)**

9. Short A3A7TP2 to ground to open the YTO Phase-Locked Loop.
10. Tune to 2100 MHz and disconnect the gray cable from the phase detector output, A3A9J6. Remove the oscilloscope probe from A3A9A5TP1.
11. Connect the spectrum analyzer's input directly to IF OUT, A3A9J2.
12. Set the sweep oscillator's controls for a center frequency of 177.5 ± 1.0 MHz and set the sweep width to 10 MHz.
13. Connect the sweep oscillator's output to the M/N LOOP SIGNAL input A3A9J5.
14. Set the spectrum analyzer's controls for a 0 to 100 MHz frequency span. Set the other controls to display the IF signal. The fundamental, second and third harmonics should be visible at 30, 60, and 90 MHz. Tune the sweep oscillator slightly to align the signals on the display.
15. Adjust the A3A9A5R1, IF GAIN, so that the displayed IF signal at 30 MHz is $+2 \pm 1$ dBm. If the level is too low, or if the levels in the following step are not within the levels given, select a new value for C22. Values should be within the range of 120 to 150 pF, and 130 is usually the best value.
16. Slowly tune the sweep oscillator's center frequency from 174 to 181 MHz and observe the fundamental's output level. Verify that the allowable level variation is not exceeded and that the power does not drop below the stated level over the frequency range:
 - a. from 6 to 20 MHz, -3 dBm minimum,
 - b. from 20 to 30 MHz, $+1$ to $+4$ dBm,
 - c. from 30 to 70 MHz, -10 dBm minimum.
17. Return the CW Generator to normal operation as follows:
 - a. Disconnect all test equipment.
 - b. Reconnect the gray cable to A3A9J6 and the white-orange cable to A3A9J3.
 - c. Reverse the instructions in step 4, 3, 2, and 1.
18. Connect the frequency counter to the CW Generator's RF OUTPUT connector.
19. Verify that the counter reading is within ± 1 kHz of the CW Generator's FREQUENCY MHz display at 2000.0 and 6199.0 MHz.

ADJUSTMENTS

5-16. YTO PHASE DETECTOR ADJUSTMENT

Reference Service Sheet 12.

Description This procedure measures and adjusts the gain crossover frequency of the YTO Phase-Locked Loop using a low frequency spectrum analyzer and tracking generator.

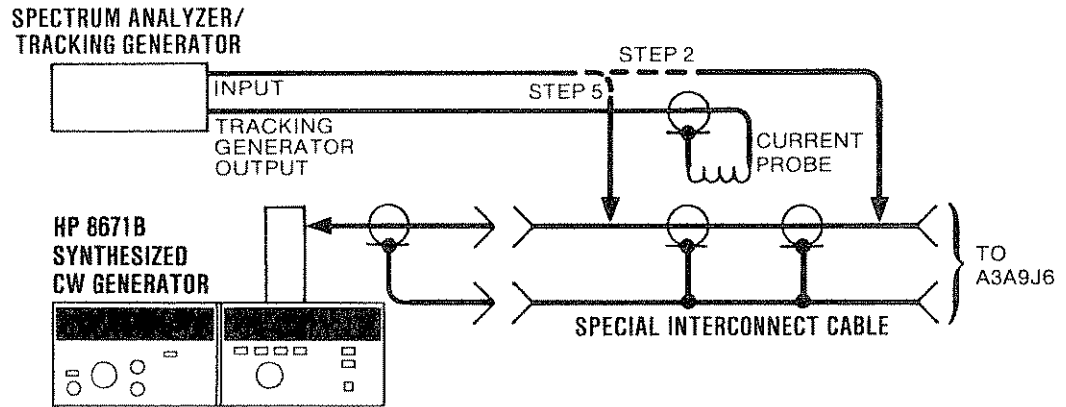

Figure 5-8. YTO Phase Detector Adjustment Test Setup

Equipment	Spectrum Analyzer	HP 8556A/8552B/141T
	(with tracking generator)	
	Current Probe	HP 1110B
	Special Interconnect Cable	(See Figure 5-9)

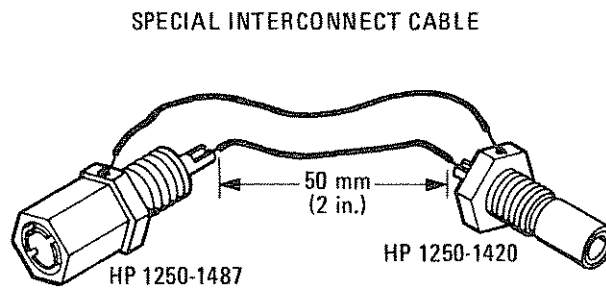

Figure 5-9. Special Interconnect Cable

ADJUSTMENTS

5-16. YTO PHASE DETECTOR ADJUSTMENTS (cont'd)**Procedure**

1. Set the CW Generator's RF OUTPUT switch to ON.
2. Connect the equipment as shown in Figure 5-8. The special interconnect cable is inserted between A3W16 (gray cable) and A3A9J6 (YTO TUNE 1).

NOTE

When clipping the current probe around the special cable's center conductor, do not allow the metal surface to come in contact with the center conductor connection of the SMA connectors.

3. Set the spectrum analyzer to scan from 0 to 50 kHz, vertical sensitivity per division to 2 dB, scan mode to single, and set the display's variable persistence to maximum.
4. Press the single sweep key on the spectrum analyzer.
5. Move the spectrum analyzer's input to the cable side (A3W16) of the special cable.
6. Press the single sweep key. Check that the gain-crossover frequency is 20 ± 2 kHz. If the gain-crossover frequency is not correct, A3A9A4R20 must be changed to set the correct frequency; otherwise, this adjustment is complete. See Figure 5-10.

18 _____ 22 kHz

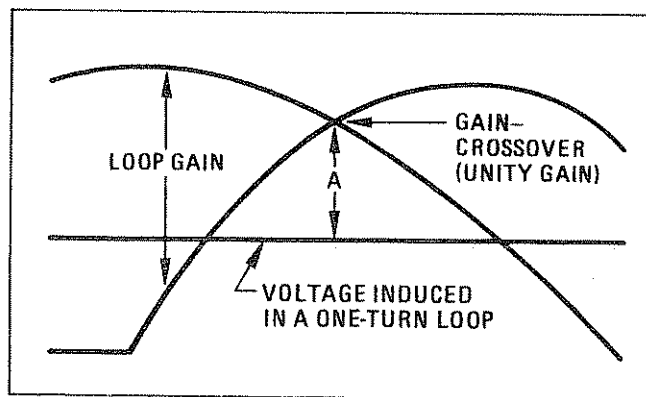

Figure 5-10. Spectrum Analyzer Display of Phase Locked Loop Gain

7. If A3A9A4R20 must be changed, perform the following steps:
 - a. Set the LINE switch to STANDBY.
 - b. Disconnect the mains power cord.
 - c. Place the A3A9 Assembly in the test position. (Refer to Section VIII disassembly procedures.)

ADJUSTMENTS

5-16. YTO PHASE DETECTOR ADJUSTMENTS (cont'd)**Procedure
(cont'd)**

- d. Remove the A3A9A4 cover.
- e. Select the value of R20 using the following formula.

$$R2 = R1 \left(\frac{F1}{20 \text{ kHz}} \right)$$

where R2 = required value for R20
 R1 = present value of R20
 F1 = measured frequency

for example, if

$$R1 = 619\Omega$$

and F1 = 25 kHz

then

$$R2 = 619 \left(\frac{25 \text{ kHz}}{20 \text{ kHz}} \right)$$

$$R2 = 773\Omega \text{ or } 750\Omega \text{ (closest value)}$$

8. Install R20, reconnect the mains power cord and set the LINE switch to ON. Recheck the gain-crossover frequency.

NOTE

The other loop parameters, phase margin and loop gain, may be checked if the loop does not operate correctly. Loop gain is checked at 1 kHz and should be approximately 40 dB. Phase margin is checked by disconnecting the input to the ac probe, shorting the input, and pressing the single sweep pushbutton. Phase margin should be approximately 45° and is calculated by the following expression:

$$\theta = \cos^{-1} \left(1 - \frac{10 \left(\frac{A}{10} \right)}{2} \right)$$

where θ = phase margin

and A = ratio (in dB) of the induced voltage to the gain-crossover.
 (Gain-crossover is the reference, therefore the ratio is negative.)

9. Return the CW Generator to normal operation as follows:
 - a. Set the LINE switch to STANDBY.
 - b. Disconnect the mains power cord.
 - c. Install the A3A9A4 cover.
 - d. Return the A3A9 Assembly to its normal position.
 - e. Install the top and bottom covers.
-

ADJUSTMENTS

5-17. YTM ADJUSTMENT

Reference Service Sheets 15 and 16.

Description The 12.4 volt reference is adjusted. A low frequency signal is applied to the tuning coil of the YTM (YIG Tuned Multiplier) to sweep the filter through its response curve. The tuning coil drive is adjusted to obtain maximum RF output from the YTM by centering the filter response about the RF output signal. The tuning coil adjustments are repeated to optimize the filter's tracking over the 2 to 18 GHz frequency range. The SRD (Step Recovery Diode) bias for the YTM is adjusted.

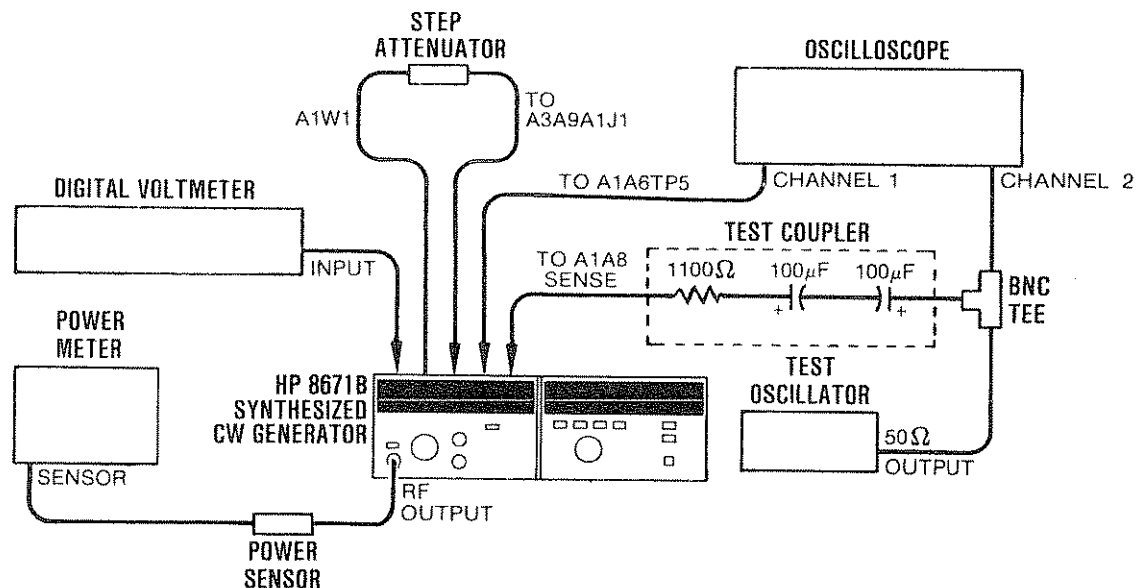

Figure 5-11. YTM Adjustment Test Setup

Equipment	Digital Voltmeter (DVM)	HP 3456A
	Oscilloscope	HP 1980B
	Power Meter	HP 436A
	Power Sensor	HP 8481A
	Step Attenuator	HP 8495A Option 002
	Test Oscillator	HP 8116A

Procedure **+12.4 Volt Reference**

1. Set the CW Generator as follows:

LINE switch	ON
RF OUTPUT	ON
ALC	XTAL
RANGE	+10 dB
VERNIER	fully clockwise
Frequency	2000.000 MHz
PEAK/NORM control	NORM
CAL control	fully clockwise

ADJUSTMENTS

5-17. YTM ADJUSTMENT (cont'd)**Procedure
(cont'd)**

2. Allow the instrument 30 minutes to warm up with these instrument settings.
3. Connect the DVM to the +12.4V test point on A1A8. Connect the ground lead to the GND test point on A1A8.
4. Adjust A1A8R64, +12.4V, for $+12.400 \pm 0.005$ Vdc.

Band 1 Adjustment (2.0 to 6.199 GHz)

5. Connect the DVM to the +C.S. test point on A1A8.
6. Adjust A1A8R46, BD1 LO, for $+8.0 \pm 0.2$ Vdc.
7. Center A1A7R31, BIAS, and A1A7R29, PWR.
8. Disconnect A1W1 from directional coupler output at A3A9A1J1 (see Service Sheet B, Top View Assembly Locations). Connect the step attenuator between A3A9A1J1 and A1W1. Connect the remaining equipment as shown in Figure 5-11.

The locally fabricated "test coupler" consists of the resistor and two capacitors shown in the figure.

9. Set the test oscillator output for 60 Hz at 900 mV peak to peak as indicated by the oscilloscope.
 10. Set the oscilloscope to 1 vs. 2 mode and adjust channel 2 sensitivity for a ten division horizontal sweep. Set channel 1 sensitivity to approximately 30 mV per division.
 11. Remove the blue cable from A2A12 RF amplifier assembly. Removing the cable disables the power clamp for this adjustment.
 12. Set the step attenuator for 10 dB attenuation. In the following steps, if the oscilloscope display shows an erratic passband response (squegging), set the attenuator for a higher attenuation. Attenuator settings of 10 to 20 dB should be sufficient to stop squegging for Band 1 frequencies. Increasing the attenuation reduces the power at the input of the YTM and also reduces the sensitivity of the displayed signal. Therefore, keep the attenuator set for as low an attenuation as necessary to stop squegging.
 13. Adjust A1A8R46, BD1 LO, at 2 GHz to center the peak of the YTM response as shown in Figure 5-12. The display may show a retrace pattern due to hysteresis in the YTM circuitry. The center of the filter passband is halfway between the peaks of the two displayed signals.
-

ADJUSTMENTS

5-17. YTM ADJUSTMENT (cont'd)

Figure 5-12. Optimum Centered YTM Response

Procedure (cont'd)

14. Tune to 6 GHz and adjust A1A8R20, BD1 HI, to center the filter response.
15. Tune from 2 to 6 GHz using 1 MHz tuning resolution while observing the oscilloscope display. The peak of the filter passband should remain within ± 5 divisions of the center of the display and should remain reasonably centered.

Readjust the step attenuator as required to maintain a smooth curve. If necessary, repeat steps 13 through 15 until the response remains reasonably well centered. The last adjustment should be at 6 GHz.

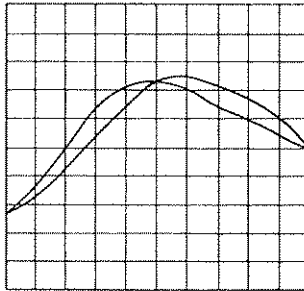
Band 2 Adjustment (6.2 to 12.399 GHz)

16. Set the step attenuator to 0 dB attenuation. The attenuator should be set to 0 dB for frequencies above 6.2 GHz.
17. Tune to 6.5 GHz and adjust A1A8R47, BD2 LO, to center the response.
18. Tune to 11.5 GHz and adjust A1A8R16, BD2 HI, to center the response.
19. Tune from 6.2 to 12.3 GHz using 1 MHz tuning resolution. The peak of the response should remain within ± 5 divisions of the center of the display and should remain reasonably centered.

Readjust the step attenuator if necessary to maintain a smooth curve. If necessary, repeat steps 17 through 19 until the response remains reasonably well centered. The last adjustment should be at 11.5 GHz.

Band 3 Adjustment (12.4 to 18.599 GHz)

20. Tune to 13 GHz and adjust A1A8R41, BD3 LO, to center the response 2.5 divisions to the right of center. The response should be as shown in Figure 5-13.

ADJUSTMENTS

5-17. YTM ADJUSTMENT (cont'd)

Figure 5-13. Optimum Offset YTM Response

Procedure (cont'd)

21. Tune to 16 GHz and adjust A1A8R11, BD3-16, to center the response 2.5 divisions to the right of center.
22. Tune to 18 GHz and wait 10 minutes for the YTM to temperature stabilize. The stabilization is required to minimize the effect of filter drift during the next adjustments.
23. Tune to 17 GHz and adjust A1A8R17, BD3-17, to center the peak of the response.
24. Tune to 18 GHz and adjust A1A8R23, BD3-18, to center the peak of the response.
25. Tune to 18.599 GHz and adjust A1A8R32, BD3-18.6, to center the peak of the response.
26. Tune from 12.4 to 16 GHz using 1 MHz tuning resolution. The peak of the response should always remain at least 4 divisions from the left edge of the display.

If necessary, repeat steps 20 and 21 to obtain the desired response. The last adjustment should be made at 16 GHz.

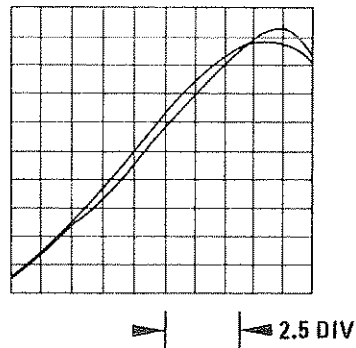
27. Tune from 16 to 18 GHz using 1 MHz tuning resolution. The peak of the response should remain within ± 5 divisions of center and remain reasonably centered.

If necessary, repeat steps 23 and 24 to obtain the desired response. The last adjustment should be made at 18 GHz.

28. Tune from 18 to 18.599 GHz using 1 MHz tuning resolution. The peak of the response should remain within ± 5 divisions of center and reasonably centered.

If necessary, repeat steps 24 and 25 to obtain the desired response. The last adjustment should be made at 18.599 GHz.

SRD Bias Adjustment

29. Disconnect the signal from A1A8 SENSE test point and disconnect the oscilloscope.
-

ADJUSTMENTS

5-17. YTM ADJUSTMENTS (cont'd)**Procedure
(cont'd)**

30. Connect the power meter to the CW Generator's output.
31. Tune to 11.5 GHz and set A1A7R29, PWR, fully counter-clockwise.
32. Reconnect the blue cable to A1A12 RF Amplifier assembly. Set the CW Generator's ALC switch to INT and set the range to 0 dB.
33. Set the VERNIER for a -10 dBm reading on the power meter. Adjust A1A6R12, INT OS, if necessary, to bring the power level within ± 3 dB of -10 dBm.
34. Connect the DVM positive lead to A1A5TP6. Connect the ground lead to A1A7 GND test point. Adjust A1A7R31, BIAS, to maximize the DVM reading.
35. Verify that the voltage at A1A7 BIAS test point is -0.5 ± 0.2 Vdc. If the voltage is not correct, service is required.
36. Disconnect the test equipment and perform the Power Clamp, ALC and Flatness adjustments.

ADJUSTMENTS

5-18. POWER CLAMP ADJUSTMENT

Reference	Service Sheet 14.
Description	The power clamp circuit is adjusted to obtain the maximum power available without squegging. Squegging is a spurious oscillation that occurs in the YTM (YIG Tuned Multiplier) at high power levels. The input power to the YTM must be limited for frequencies between 2.0 and 6.2 GHz to prevent erratic power variations due to squegging.
Equipment	Power Meter HP 436A Power Sensor HP 8481A
Procedure	<ol style="list-style-type: none"> 1. Connect the power meter and sensor to the CW Generator. 2. Set the CW Generator's frequency to 5 GHz. Set the CW Generator RANGE to 0 dB and the ALC switch to XTAL. Set the RF OUTPUT switch to OFF. 3. Set A1A5R76, PWR CLAMP, fully clockwise. This sets the power clamp for minimum power level. 4. Set the RF OUTPUT switch to ON. Adjust A1A5R76, PWR CLAMP, slowly counter-clockwise to +15.0 dBm on the power meter. If the level drops suddenly by several dB, set the RF OUTPUT switch to OFF and rotate A1A5R76, PWR CLAMP, clockwise slightly to reduce the clamp level. Set the RF OUTPUT switch to ON and continue with step 5. 5. Tune the CW Generator from 2.0 to 6.1 GHz using 100 MHz steps. The power level should not change more than ± 1 dB from the level set in step 4. If a sudden drop in output level occurs, reduce the clamp level by 0.5 dB and repeat this step. 6. Reduce the clamp level by 0.5 dB to ensure best stability with time.

ADJUSTMENTS

5-19. ALC ADJUSTMENTS

Description	The ALC (Automatic Level Control) circuitry offsets are adjusted for proper operation. The meter is calibrated to indicate output level. The +10 dB (Overrange) range circuitry is calibrated, and the absolute ALC level with respect to the vernier voltage is calibrated.
Equipment	Digital Voltmeter (DVM)HP 3456A Power MeterHP 436A Power SensorHP 8481A
Procedure	<p>ALC Offsets</p> <ol style="list-style-type: none"> 1. Connect the power meter and sensor to the CW Generator. 2. Set the CW Generator's frequency to 4 GHz. Set the power meter CAL factor for 4 GHz. 3. Set the CW Generator RANGE to 0 dB and the ALC switch to INT. Adjust the VERNIER for a power meter reading of -4 dBm. 4. Connect the DVM to A1A5TP4. Connect the ground lead to the A1A5 GND test point. Verify that the LVL UNCAL annunciator is not lighted. Adjust A1A5R7, OS, for a DVM reading of 130.0 ± 0.5 mVdc. 5. Adjust the CW Generator's VERNIER control for a power meter reading of 0.0 ± 0.5 dBm. Set the RF OUTPUT switch to OFF. 6. Connect the DVM to A1A6TP5. Connect the ground lead to the A1A6 GND (not GND2) test point. Adjust A1A6R12, INT OS, for a DVM indication of 0.00 ± 0.01 mVdc. <p>Level Meter</p> <ol style="list-style-type: none"> 7. Set the OUTPUT LEVEL RANGE to 0 dB and set the RF OUTPUT switch to ON. Connect the DVM to the A1A10 DAC test point. Connect the ground lead to the A1A10 REF GND test point. Adjust the VERNIER for a DVM indication of -6.50 ± 0.05 Vdc. -6.50 Vdc corresponds to an ALC reference voltage for -10 dBm. 8. Adjust A1A10R31, GAIN, (near REF GND), for a front panel meter reading of -10 dBm. 9. Adjust the VERNIER for a DVM reading of -1.50 ± 0.05 Vdc (corresponding to 0 dBm). 10. Adjust A1A5R69, MET CAL, for a front panel meter reading of 0.0 dBm. 11. Repeat steps 7 through 10 until there is less than 0.1 dB change at the last adjustment. <p>Overrange</p> <ol style="list-style-type: none"> 12. Set the power meter to read dB relative (dB REL). This adjustment will set the -10 dBm VERNIER setting in the +10 dB RANGE equal to the 0 dBm VERNIER setting on the 0 dB RANGE.

ADJUSTMENTS

5-19. ALC ADJUSTMENTS (cont'd)**Procedure
(cont'd)**

13. Set the OUTPUT LEVEL RANGE to +10 dB. Adjust the CW Generator's VERNIER control for a DVM indication of -6.50 ± 0.05 Vdc (-10 dBm).
14. Adjust A1A6R36, OVERRANGE, for a power meter reading of 0.00 ± 0.01 dB.

ALC Absolute Level

15. Set the power meter to read absolute power (dBm). Set the OUTPUT LEVEL RANGE to 0 dB and adjust the VERNIER for a DVM reading of -3.00 ± 0.05 Vdc. -3 Vdc corresponds to an ALC reference voltage for -3 dBm.

Adjust A1A6R33, -3, for a power meter reading of -3.0 ± 0.1 dBm.

16. Adjust the CW Generator's VERNIER control for a DVM reading of -6.50 ± 0.05 Vdc (-10 dBm reference).

Adjust A1A6R39, -10, for a power meter reading of -10.0 ± 0.1 dBm.

17. Set the OUTPUT LEVEL RANGE to +10 dB. Adjust the CW Generator's VERNIER control for a DVM reading of -2.50 ± 0.05 Vdc (-2 dBm reference).

Adjust A1A6R28, +8, for a power meter reading of $+8.0 \pm 0.1$ dBm.

18. Repeat steps 15 through 17 until less than 0.1 dB improvement can be made.
19. Disconnect the DVM from the CW Generator and perform the Flatness Adjustment.

ADJUSTMENTS

5-20. FLATNESS ADJUSTMENT

Reference	Service Sheet 16.
Description	The Flatness Adjustment reduces power variations due to output cable, attenuator, crystal detector, and directional coupler variations.
Equipment	Digital Voltmeter (DVM)HP 3456A Power MeterHP 436A Power SensorHP 8481A
Procedure	<ol style="list-style-type: none"> 1. Connect the power meter and sensor to the CW Generator. 2. Set the CW Generator's frequency to 4 GHz.

NOTE

After each frequency change, make sure the power meter CAL factor is adjusted for the new frequency.

3. Set the OUTPUT LEVEL RANGE to 0 dB and the ALC switch to INT.
Adjust the CW Generator's VERNIER control for a front panel meter reading of 0 dBm.
4. Set the power meter to read dB relative (dB REL).
5. Set the CW Generator's frequency to 10 GHz. Adjust A1A7R18, SLOPE 10 GHz, for a power meter reading of 0 dB.
6. Set the CW Generator's frequency to 18 GHz. Adjust A1A7R4, SLOPE 18 GHz, for a power meter reading of 0 dB.
7. Set the CW Generator's frequency to 17 GHz. Adjust A1A7R4, SLOPE 18 GHz, for the best overall output power accuracy between 17 and 18 GHz.

ADJUSTMENTS

5-21. EXTERNAL LEVELING ADJUSTMENT

- Reference** Service Sheet 17.
- Description** The external ALC (Automatic Level Control) amplifier is adjusted for zero offset. The +10 dB range is calibrated for external leveling modes.
- Equipment**
- | | |
|-------------------------------|-----------|
| Digital Voltmeter (DVM) | HP 3456A |
| Power Meter | HP 436A |
| Power Sensor | HP 8481A |
| 50Ω Termination | HP 11593A |
- Procedure**
1. Set the CW Generator's frequency to 4 GHz. Connect a 50 ohm load to the CW Generator's EXT ALC input connector.
 2. Connect the DVM between A1A6TP6 and A1A6TP8 (GND 2). Adjust A1A6R15, EXT OS, for a reading of 0.0 ± 0.1 mVdc. Disconnect the 50 ohm load and the DVM.
 3. Connect the power meter and sensor to the CW Generator as shown in Figure 5-14.

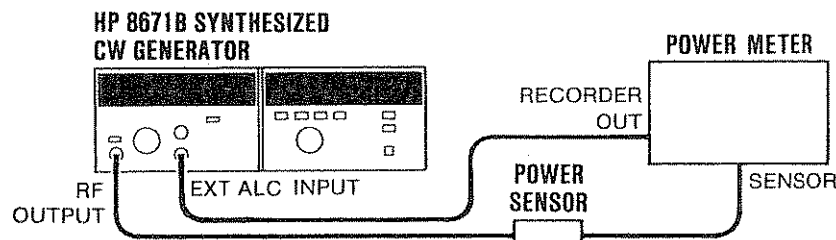

Figure 5-14. External Leveling Adjustment Test Setup

4. Set the CW Generator's frequency to 4 GHz. Adjust the CAL factor on the power meter for 4 GHz.
5. Set the OUTPUT LEVEL RANGE to 0 dB and the ALC switch to INT. Adjust the CW Generator's VERNIER control for a power meter reading of -5 ± 1 dBm. Press the range hold key on the power meter.
6. Connect the DVM to A1A10 DAC test point and A1A10 REF GND. Set the CW Generator's ALC switch to PWR MTR.
7. Set the OUTPUT LEVEL RANGE to 0 dB. Adjust the CW Generator's VERNIER control for a DVM reading of -1.50 ± 0.05 Vdc. Adjust the CW Generator's front panel CAL control for a power meter reading of -10.0 ± 0.1 dBm.
8. Set the OUTPUT LEVEL RANGE to +10 dBm. Adjust A1A6R38, EXT GAIN, for a power meter reading of 0.0 ± 0.1 dBm.
9. Repeat steps 7 and 8 until there is less than 0.1 dB change at the last adjustment.
10. Disconnect the power meter from the CW Generator.

