

Quick Reference Guide

Agilent Technologies 8560 E-Series and EC-Series Spectrum Analyzers



Agilent Technologies

Manufacturing Part Number: 08560-90159

Printed in USA November 2000

© Copyright 1993 – 2000 Agilent Technologies

Notice.

The information contained in this document is subject to change without notice.

Agilent Technologies makes no warranty of any kind with regard to this material, including but not limited to, the implied warranties of merchantability and fitness for a particular purpose. Agilent Technologies shall not be liable for errors contained herein or for incidental or consequential damages in connection with the furnishing, performance, or use of this material.

© Copyright Agilent Technologies 1993 - 2000
All Rights Reserved. Reproduction, adaptation, or translation without prior written permission is prohibited, except as allowed under the copyright laws.
1400 Fountaingrove Parkway, Santa Rosa, CA 95403-1799, USA

Introduction

This Quick Reference Guide is a convenient reference for both manual and automated measurements. It is provided for the experienced spectrum analyzer user.

- Chapter 1 gives an overview of front-panel keys and connectors, rear-panel connectors, and display annotation.
- Chapter 2 leads you through a simple measurement procedure.
- Chapter 3 diagrams the front-panel key location menus.
- Chapter 4 documents front-panel key and softkey functions.
- Chapter 5 documents programming commands and information.
- Chapter 6 documents the error messages.
- Appendix A provides simplified block diagrams of the instruments.

For additional instrument information, consult the:

Agilent Technologies 8560 E-Series and EC-Series Spectrum Analyzers User's Guide

Agilent Technologies 8560 E-Series and EC-Series Spectrum Analyzers Calibration Guide

— |

| —

— |

| —

Contents

1. Instrument Overview	
The Front Panel	1-2
Display Annotation	1-6
The Rear Panel	1-8
2. Making a Basic Measurement	
Reference Level Calibration	2-6
3. Menu Trees	
4. Front Panel Key Functions	
Finding the Front Panel Key	4-2
Key Descriptions	4-15
5. Programming Reference	
Programming Commands (functional index)	5-2
Key versus Programming Command	5-22
Mass Memory Module Commands	5-37
Programming Commands (alphabetical index)	5-42
Notation Conventions	5-88
Syntax Conventions	5-89
Secondary Key Word Summary	5-90
6. Error Messages	
A. Block Diagrams	

Figures

1-1. 8560 E-Series and EC-Series Front Panel	1-2
1-2. Display Annotation	1-6
1-3. 8560 E-Series Rear Panel	1-8
1-4. 8560 EC-Series Rear Panel	1-9
2-1. 300 MHz Center Frequency	2-2
2-2. 20 MHz Frequency Span	2-3
2-3. Activated Normal Marker	2-4
2-4. -10 dBm Reference Level	2-5
2-5. Peaked Signal to Reference Level	2-7

Tables

1-1. Front-Panel Connector Data	1-4
4-1. Front Panel Softkey Access	4-2
4-2. Conversion-Loss Flatness Data	4-21
4-3. External Mixing Frequency Bands and Recommended Harmonics (For Unpreselected External Mixers)	4-25
5-1. Front Panel Key Versus Command	5-22
5-2. Mass Memory Module Commands	5-37
6-1. Remote Operation Errors	6-2
6-2. Data and Other User-Generated Errors	6-4

1

Instrument Overview

This chapter introduces the front-panel and rear-panel keys and connectors on the 8560 E-Series and EC-Series spectrum analyzers. Complete descriptions of each front-panel function are in Chapter 5 of the 8560 E-Series and 8560 EC-Series User's Guide.

The Front Panel

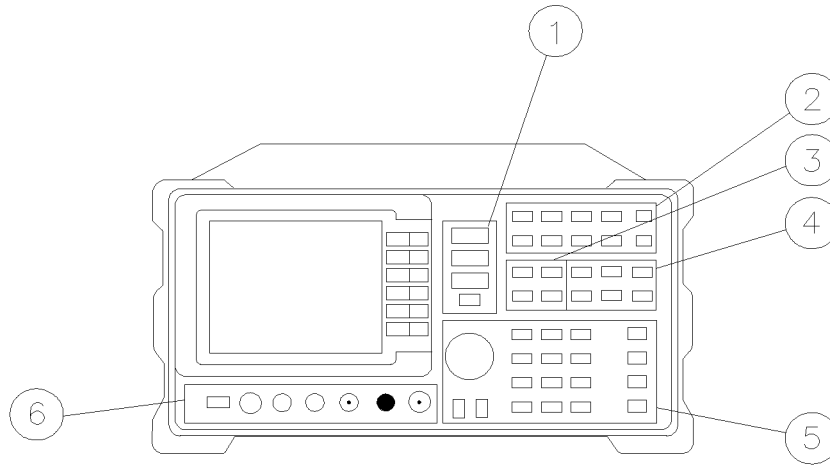

qj11e

Figure 1-1. 8560 E-Series and EC-Series Front Panel

1. **FREQUENCY, SPAN, and AMPLITUDE** are the fundamental functions for most measurements. The **HOLD** key freezes the active function and holds it at a set value until a function key is pressed again. **HOLD** also blanks the softkey menu and expands the graticule display horizontally to fill the full CRT.
2. **INSTRUMENT STATE** functions generally affect the state of the entire spectrum analyzer, not just the state of a single function.
3. **MARKER** functions read out frequencies and amplitudes along the spectrum analyzer trace, let you make relative measurements, automatically locate the signal of highest amplitude on a trace, and tune the analyzer to track a signal automatically.
4. **CONTROL** functions allow you to adjust the resolution and video bandwidths, the sweep time, and the display, and let you vary other functions that control spectrum analyzer measurement capabilities.

1-2 Instrument Overview

5. DATA keys, STEP keys, and the knob allow you to change the numeric value of an active function. Use the data keys to enter an exact value or to move quickly from one end of the frequency range to the other. The step keys vary a value in predefined increments or, for some functions, in increments that you choose. The knob allows you to fine-tune most numeric values.
6. The front-panel connectors include an RF input, an active-probe power, a 300 MHz calibrator signal, a 310.7 MHz IF input (not available on the 8560E/EC ,Option 002), and a first LO output. A short specification summary of these connectors is outlined in Table 1-1. A volume knob is provided for making adjustments to the volume of the built-in speaker. The LINE button turns the spectrum analyzer on and off. The LED above the LINE button indicates whether or not ac power is applied to the spectrum analyzer.

Caution

Do not exceed the maximum safe input levels. This can damage the input attenuator and the input mixer. The maximum input level to the 50 Ω RF input is +30 dBm with a minimum of 10 dB input attenuation.

The 8560E/EC, 8561E/EC, and 8562E/EC can be ac or dc coupled. When ac coupled, the maximum dc input voltage is ± 50 V. When dc coupled, the maximum dc input voltage <0.2 V. The default power-up mode is ac coupled, which is best for maximum protection.

The 8563E/EC, 8564E/EC, and 8565E/EC are dc coupled only. A maximum of 0.2 V dc should be input. Option 006, which extends the frequency coverage down to 30 Hz, is especially susceptible to damage from dc voltages.

Table 1-1. Front-Panel Connector Data

Connector	Frequency Range	Amplitude/ Voltage Limits
INPUT 50Ω	8560E/EC 30 Hz — 2.9 GHz (dc coupled) 100 kHz — 2.9 GHz (ac coupled)	+30 dBm Max 0.2 V dc Max (dc coupled) 50 V dc Max (ac coupled)
	8561E/EC 30 Hz — 6.5 GHz (dc coupled) 100 kHz — 6.5 GHz (ac coupled)	+30 dBm Max 0.2 V dc Max (dc coupled) 50 V dc Max (ac coupled)
	8562E/EC 30 Hz — 13.2 GHz (dc coupled) 100 kHz — 13.2 GHz (ac coupled)	+30 dBm Max 0.2 V dc Max (dc coupled) 50 V dc Max (ac coupled)
	8563E/EC 9 kHz — 26.5 GHz (dc coupled) Option 006 30 Hz — 26.5 GHz (dc coupled)	+30 dBm Max 0.2 V dc Max (dc coupled)
	8564E/EC 9 kHz — 40 GHz (dc coupled) Option 006 30 Hz — 40 GHz (dc coupled)	+30 dBm Max 0.2 V dc Max (dc coupled)
	8565E/EC 9 kHz — 50 GHz (dc coupled) Option 006 30 Hz — 50 GHz (dc coupled)	+30 dBm Max 0.2 V dc Max (dc coupled)
	PROBE POWER	— +15 V, -12.6 V (150 mA max)
	CAL OUTPUT	300 MHz -10 dBm ±0.3 dB
	IF INPUT* (for use with external mixers)	310.7 MHz 0 V dc Max
	1ST LO OUTPUT	3.00 GHz — 6.81 GHz +16.5 dBm ±2.0 dB +14.5 dBm ±3.0 dB†
RF OUT 50Ω‡	300 kHz — 2.9 GHz -10 dBm to +1 dBm	
* Not available with Option 002 or Option 327.		
† LO output of an 8560E/EC Option 002.		
‡ Available only with an 8560E/EC Option 002.		

1-4 Instrument Overview

This page intentionally left blank.

Display Annotation

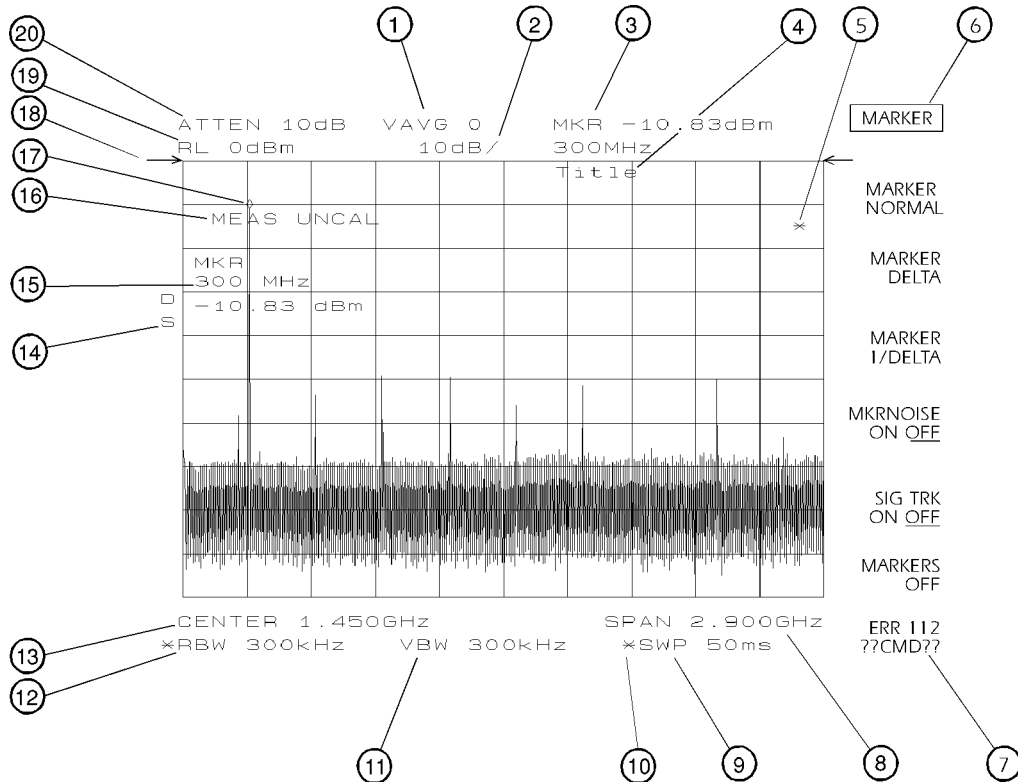

Figure 1-2. Display Annotation

1. Number of video averages.
2. Logarithmic or linear amplitude scale per division.
3. Marker amplitude and frequency.
4. Title area.
5. Data invalid indicator, displayed when analyzer settings are changed before completion of a full sweep.
6. Menu title and softkey menu.
7. Error message area.
8. Frequency span or stop frequency.

1-6 Instrument Overview

9. Sweep time.
10. Indicator of uncoupled function for sweep time, resolution bandwidth, video bandwidth, or input attenuation.
11. Video bandwidth.
12. Resolution bandwidth.
13. Center or start frequency.
14. Active special functions: these characters appear along the left edge of the display. Press **DISPLAY**, **ANNOT HELP** to view this information.
 - A = IF adjust turned OFF
 - C = DC coupling selected (ac coupling is default)
 - D = Detector mode set to sample, negative peak, or positive peak
 - E = SR sweep-time equations in use (refer to tracking generator menus)
 - F = Frequency offset is less than or greater than 0 Hz
 - G = Internal tracking generator is ON
 - K = Signal track is ON
 - M = Trace math is ON
 - N = Normalization is ON
 - R = Reference level offset is less than or greater than 0 dB
 - S = Single-sweep mode
 - T = Trigger mode set to line, video, or external
 - W = Amplitude correction (ampcor) is ON
 - X = 10 MHz reference is external
 - + = External mixer bias is greater than 0 mA
 - = External mixer bias is less than 0 mA
15. Active function area.
16. Message area.
17. Marker indicator.
18. Indicator of reference-level position when in normalized mode.
19. Reference level.
20. Input attenuator value (internal mixing) or conversion loss (external mixing).

The Rear Panel

The functions available from the rear panels of the 8560 E-series and the 8560 EC-series are shown in Figure 1-3 and Figure 1-4; 8560 E-series and EC-series instruments are functionally identical, except that 8560 EC-series instruments offer a VGA port. Descriptions of these functions follow.

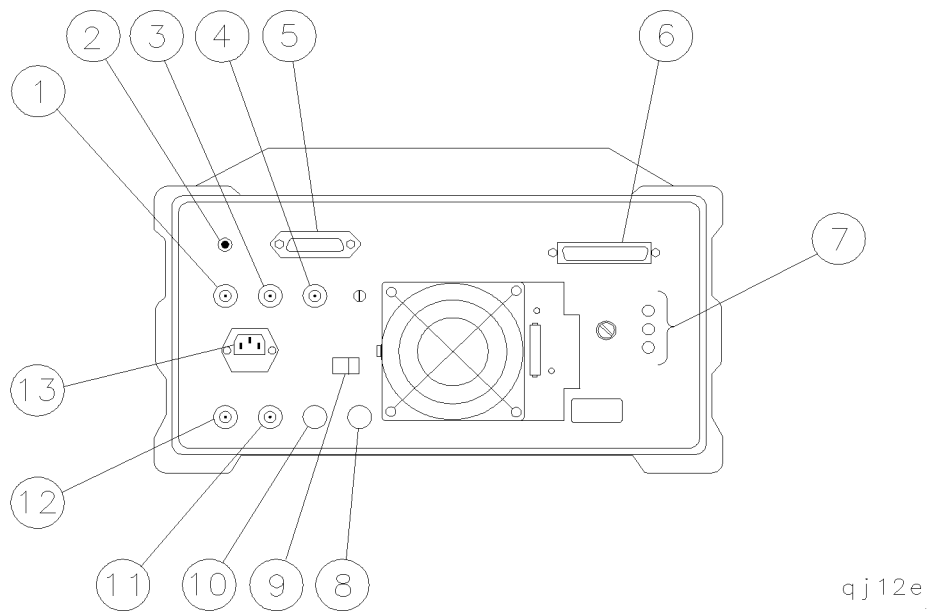
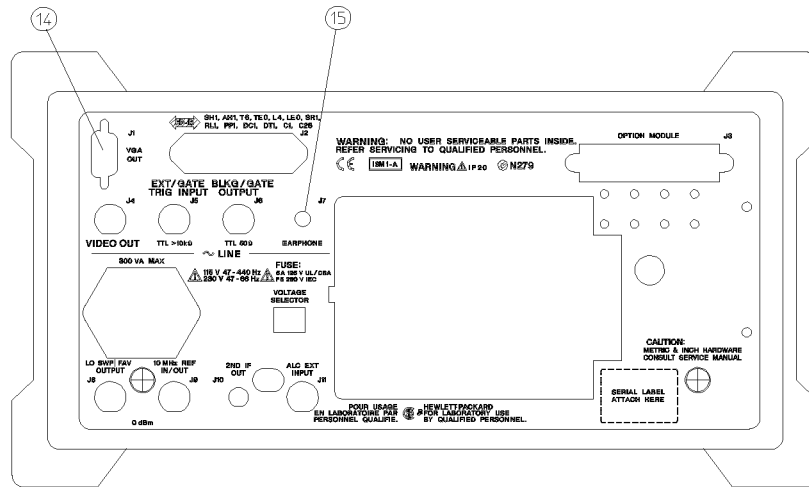

Figure 1-3. 8560 E-Series Rear Panel



pj12c

Figure 1-4. 8560 EC-Series Rear Panel

Caution

To prevent damage to the instrument, be sure to set the voltage selector to the appropriate value for your local line-voltage output. (Item 9 in Figure 1-3.) For more information, refer to the user's guide.

1. J4 provides a detected video signal proportional to the vertical deflection of the displayed trace. The output range is nominally 0 V to 1 V when terminated in 50Ω, and can be used when the display is in 10 dB per division or LINEAR mode. For resolution bandwidth settings less than 300 Hz, a 4.8 kHz IF signal with a dc offset is present at J4. The video output connector is deleted in Option 327.
2. J1 provides a 4Ω impedance earphone jack for 8560 E-series instruments.
3. J5 accepts a TTL signal as an external trigger, or as a trigger for gated video. The input signal range is 0 V to 5 V (TTL). When the spectrum analyzer is in the external trigger mode, the instrument sweep triggers on the rising or falling edge (as determined by `TRIG POL POS NEG`) of the signal at about +1.5 V. When the spectrum analyzer is configured to trigger in gated video mode, the instrument sweep trigger depends upon the setting of `GATE CTL EDGE LVL`.
4. J6 provides either blanking output or gate output. The blanking output is 0 V to 5 V (TTL) that is low (0 V) during spectrum analyzer sweeps. The output is high (5 V) during retrace and when the instrument is between bands in multiband sweeps. Use the blanking output for pen lift when plotting with nondigital plotters. This output is also useful for synchronizing instruments. When used as the gate output, it provides a TTL signal that indicates the status of the gate when the gate is in edge trigger mode. A high TTL signal indicates the gate is on, while a low TTL signal indicates the gate is off. The gate output is not active in level mode.
5. J2 is the General Purpose Interface Bus (GPIB) connector.
6. J3 allows connection of option modules, such as the 85620A mass memory module or the 85629B test and adjustment module (TAM). The 85629B is not compatible with the 8564E/EC or 8565E/EC. The 562E/TAM Interface Software is required when using the TAM with the 8562E spectrum analyzer.
7. X POSN, Y POSN, and TRACE ALIGN on 8560 E-series instruments allow you to align the spectrum analyzer display using a special pattern. Refer to the softkey `CRT ADJ PATTERN` under the `CAL` menu, or consult the user's guide. 8560 EC-series instruments are not adjustable.

1-10 Instrument Overview

8. J11 is either an alternate sweep output with Option 005, or an external leveling input with an 8560E/EC Option 002 (built-in tracking generator).
9. The VOLTAGE SELECTION switch changes the line voltage setting for the appropriate local voltage.
10. J10 is the output for the 310.7 MHz IF output. (Option 001)
11. J9 provides a 10 MHz, 0 dBm minimum, time-base reference signal. This connector can be switched to an input, in order to connect an external reference. An external reference must be 10 MHz at a minimum of 0 dBm. To select the external reference mode, use the softkey `10 MHz EXT INT` in the `REAR PANEL` softkey menu under the `AUX CTRL` key.
12. J8 provides different selectable outputs: a 0 V to 10 V ramp corresponding to the sweep ramp that tunes the local oscillator, or a sweeping dc output of 0.5 V/GHz (0.25 V/GHz is also available with the 8564E/EC and 8565E/EC). The output can be selected from the softkeys available when you press `AUX CTRL` and `REAR PANEL`. External tracking generators, such as the 85640A, require the 0.5 V/GHz output for operation. When you have selected preselected external mixers, the 0.5 V/GHz output provides a signal of approximately 1.5 V/GHz of LO frequency to control the mixer.
13. The LINE input operates at nominally 115 V (47 Hz to 440 Hz) or at nominally 230 V (47 Hz to 66 Hz).
14. J1 on 8560 EC-series instruments provides a VGA port. The VGA port is always active and does not require user interface.
15. J7 provides a 4 Ω impedance earphone jack for 8560 EC-series instruments.

— |

| —

— |

| —

2

Making a Basic Measurement

A basic measurement involves tuning the spectrum analyzer to place a signal on the screen, then measuring the frequency and amplitude of the signal with a marker.

We can measure an input signal in four simple steps:

1. Set the center **frequency**.
2. Set the frequency **span**.
3. Activate the **marker**.
4. Set the **amplitude**.

As an example, we will measure the 300 MHz calibration signal. First, switch on the spectrum analyzer (for maximum accuracy, if the analyzer has just been powered up, allow for a 5-minute warmup). Connect the analyzer CAL OUTPUT to the INPUT 50Ω on the front panel, and complete these steps:

1. Set the center frequency.

Press **FREQUENCY**. This activates the center frequency function, indicated by **CENTER** appearing in the active function block on the left side of the display. See Figure 2-1. To set the center frequency to 300 MHz, use the keys in the DATA section of the front panel to enter 300 MHz. These data keys allow you to select the exact numeric value of the active function, which, in this case, is the center frequency. The step keys and knob also allow you to select function values.

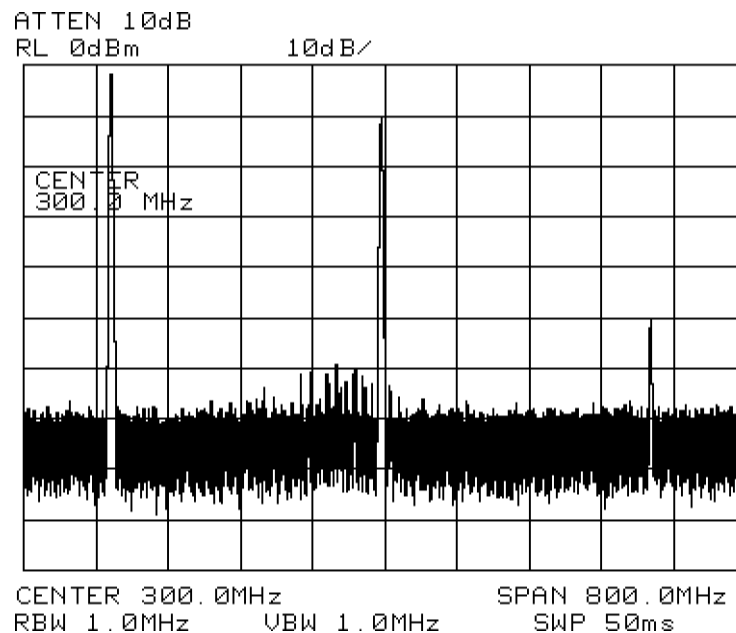

Figure 2-1. 300 MHz Center Frequency

2-2 Making a Basic Measurement

2. Set the frequency span.

Press **SPAN**. Note that **SPAN** is now displayed in the active function block, identifying it as the current active function. To reduce the frequency span—for example, to 20 MHz—either key in 20 MHz, or use the **STEP** (↓) key to “step down” to this value. (Like data keys, step keys can also be used to change the numeric value of the active function.) The resulting display is shown in Figure 2-2. Note that the resolution and video bandwidths are coupled to the frequency span; they are automatically adjusted to appropriate values for a given span. Sweep time is a coupled function also.

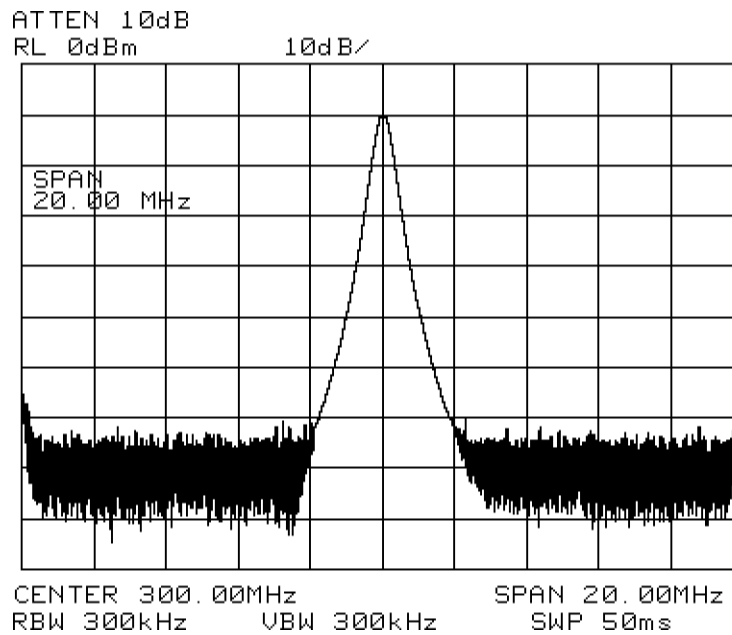

Figure 2-2. 20 MHz Frequency Span

3. Activate the marker.

Press **(MKR)**, which is located in the **MARKER** section of the front panel. This activates the normal marker and places it at the center of the trace (in this case, at or near the peak of the signal). Use the knob to place the marker at the peak of the signal. The marker reads both the frequency and the amplitude, and displays these values in the active function block. In this case, the marker reads 300.00 MHz and -10.00 dBm, as shown in Figure 2-3.

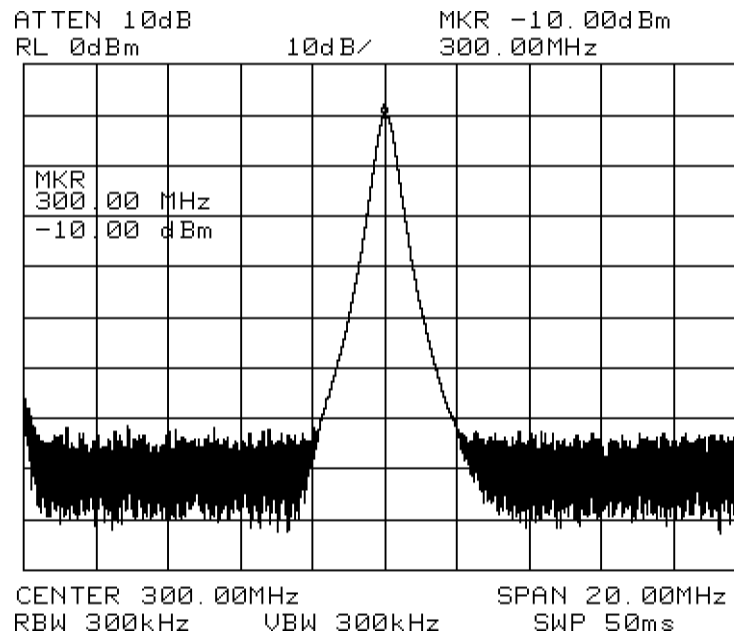

Figure 2-3. Activated Normal Marker

2-4 Making a Basic Measurement

4. Set the amplitude.

Generally, placing the signal peak at the reference level provides the best measurement accuracy. When a marker is active, a fast method to fine-tune the signal peak to the reference level is to use **MARKER** → **REF LVL**, which is located under the **(MKR→)** key. This function sets the reference level equal to the marker amplitude value. See Figure 2-4. When no marker is active, to adjust the signal peak to the reference level, press **(AMPLITUDE)**, then key in -10 dBm, or use either the step keys or the knob. Using the knob is the easiest way to fine-tune the signal peak to the reference level, which is located at the top of the graticule.

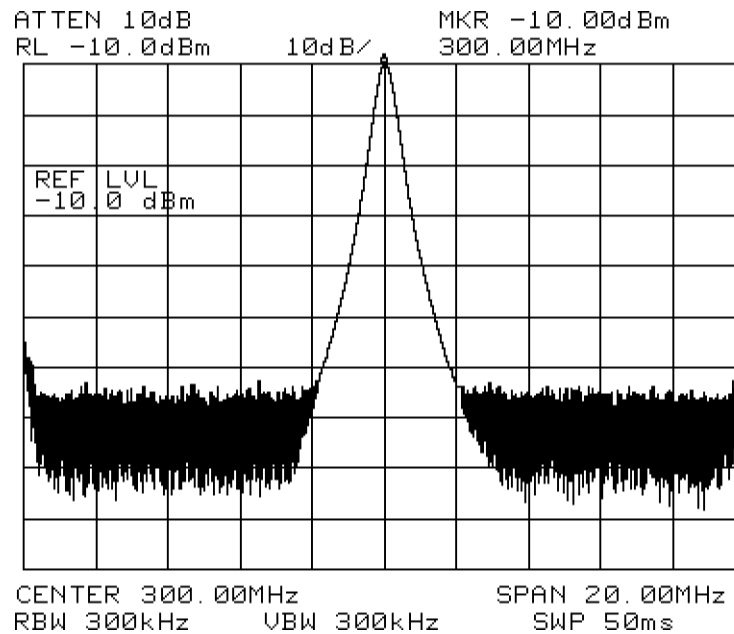

Figure 2-4. -10 dBm Reference Level

Reference Level Calibration

The reference-level calibration function, **REF LVL ADJ**, allows the spectrum analyzer internal gain to be adjusted so that when the calibrator is connected to the input, the reference level at top-screen equals the calibrator amplitude. Use the instrument state from the previous example and follow the procedure below to calibrate the reference level.

Turn the marker off by pressing **(MKR)**, **MARKERS OFF**. Press **(CAL)**. This accesses a menu of calibration routines. The fifth softkey function on this list is **REF LVL ADJ**. Press **REF LVL ADJ** to activate the function. To calibrate the spectrum analyzer, use the knob on the front panel to adjust the peak of the signal to the reference level, as shown in Figure 2-5.

Note the number that appears in the active function block. In this example, the number 0 appears when the signal is adjusted. This number, which ranges from -528 to +528 (-33 to +33 for firmware revisions ≤ 920528), is a relative value indicating how much amplitude correction was required to calibrate the spectrum analyzer. The number is usually around 0. If the amplitude is at either end of the range, or if it cannot be adjusted to a value within this range, consult the user's guide. To store the value, press **STORE REF LVL**. When entering or storing a value using the data keys, the entry must be terminated by pressing **(ENTER)**, which is located in the lower right-hand corner of the spectrum analyzer.

Reference Level Calibration

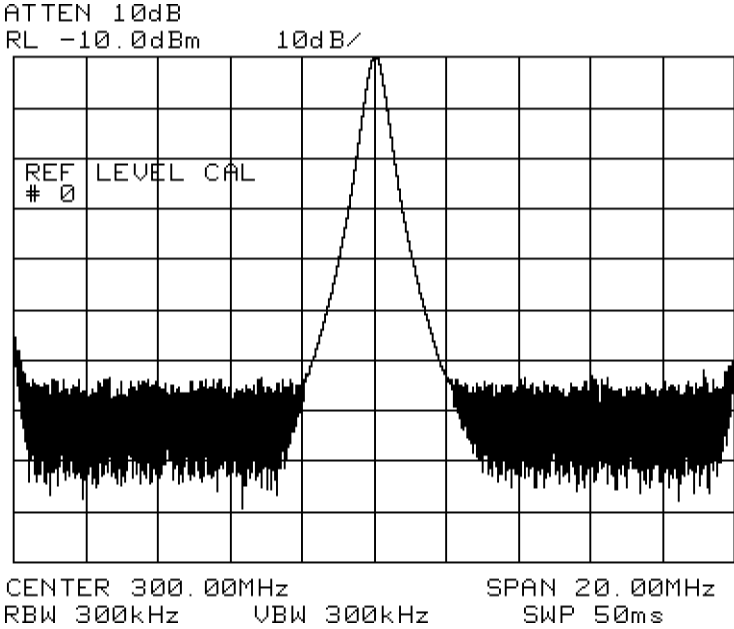

Figure 2-5. Peaked Signal to Reference Level

Recalibrating the reference level is usually necessary only when the ambient temperature changes more than 10° C. Because the spectrum analyzer continually monitors and reduces any IF errors, executing the reference-level calibration is seldom necessary.

— |

| —

— |

| —

3

Menu Trees

This chapter illustrates the different softkey menus available when pressing the front-panel keys.

AMPLITUDE

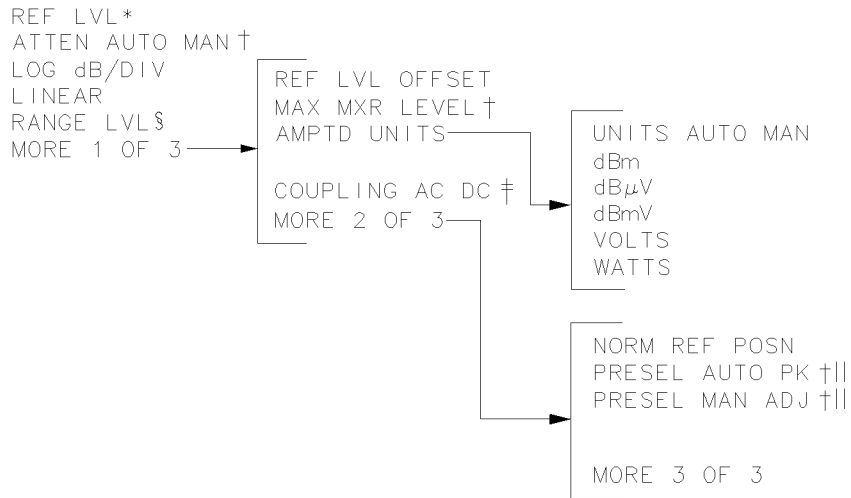

qj15e

* Becomes **NORM REF LVL** when **NORMLIZE ON OFF** is set to ON.

† Available only with internal mixing.

‡ Not available for an 8563E/EC, 8564E/EC, or 8565E/EC.

§ Available only when **NORMLIZE ON OFF** is set to ON.

|| Not available for an 8560E/EC.

3-2 Menu Trees

AUTO
COUPLE

ALL
RES BW AUTO MAN
VIDEO BW AUTO MAN
SWP TIME AUTO MAN
ATTEN AUTO MAN *
MORE 1 OF 2

CF STEP AUTO MAN
UNITS AUTO MAN

MORE 2 OF 2

qj16e

* Available only with internal mixing.

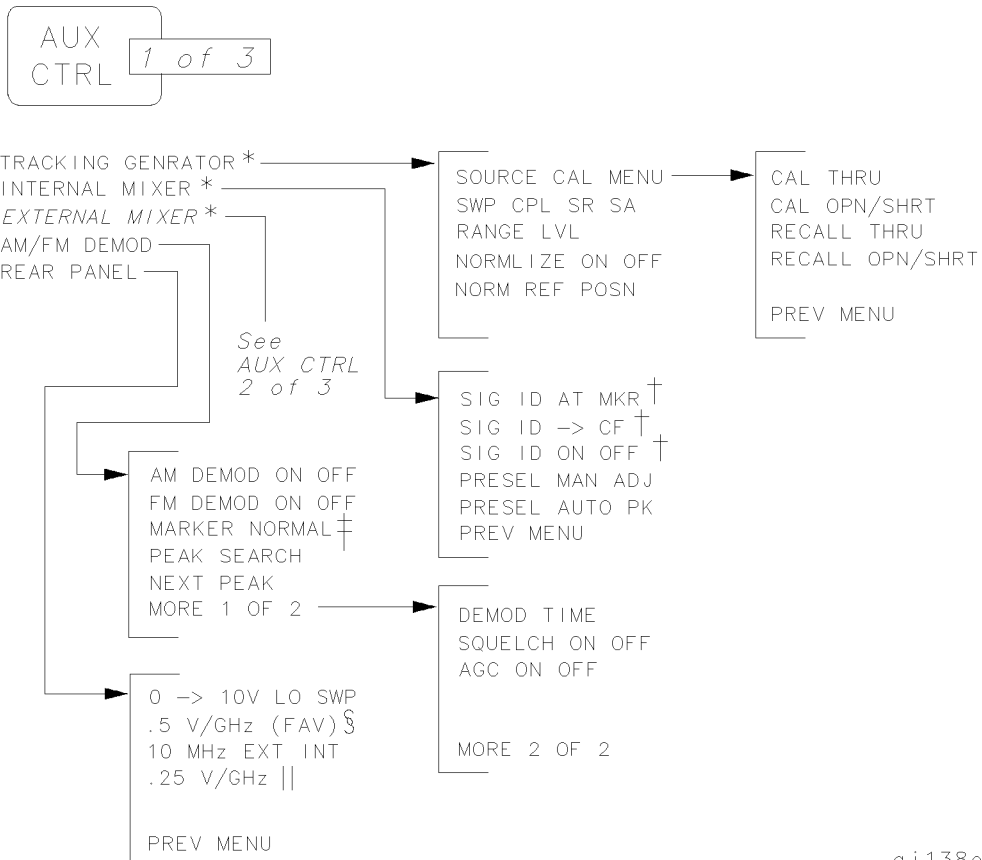

qj138e

3-4 Menu Trees

* The **TRACKING GENERATOR** menu shown here is for spectrum analyzers without Option 002 installed. See AUX CTRL menu 3 of 3 for an 8560E/EC with Option 002 installed.

INTERNAL MIXER is not shown for an 8560E with Option 002 installed. For an 8560E/EC without Option 002, only the INTERNAL MIXER softkey is available (the softkeys accessed by **INTERNAL MIXER** are not available).

EXTERNAL MIXER is not shown for an 8560E with Option 002 installed and it is non-functional for Option 327.

† Signal identification functions are only available in non-preselected external mixing mode, with firmware revisions ≤ 920528 , or with Option 008 installed.

‡ This key changes to **MARKER DELTA** if the marker delta function is active.

§ This key changes to **V/GHz .25 .50** for the 8564E/EC and 8565E/EC.

|| This key is present only for the 8564E/EC and 8565E/EC.

AUX CTRL 2 of 3

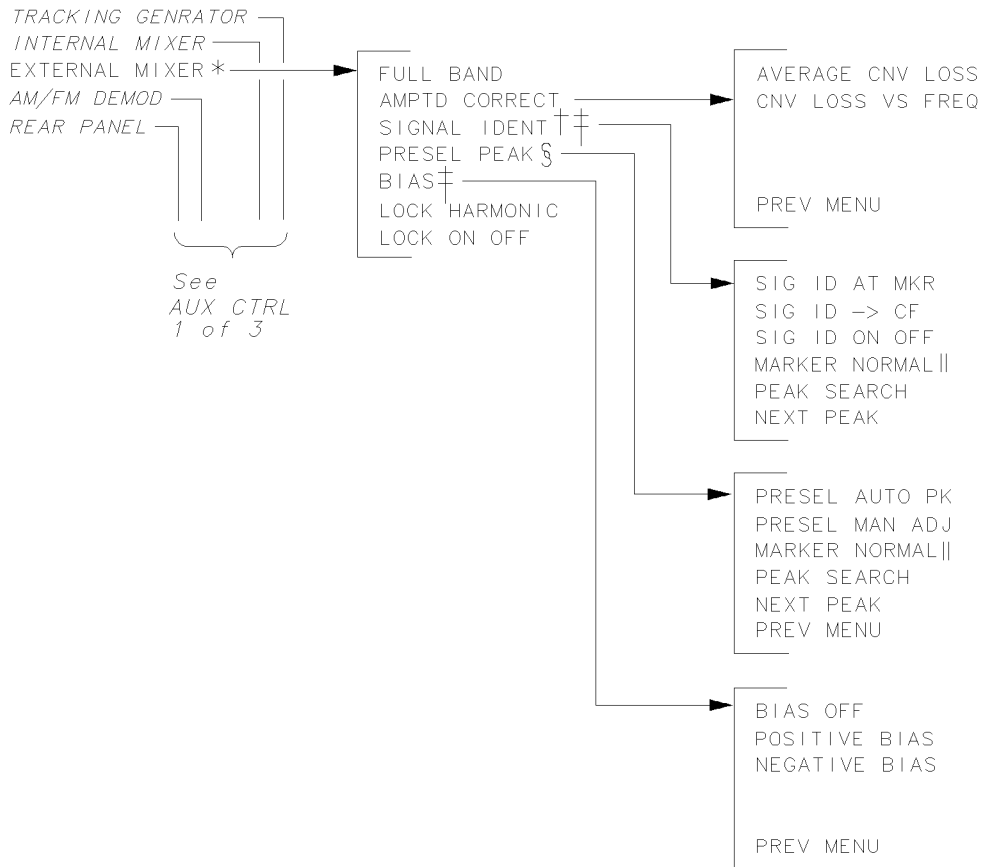

qj139e

3-6 Menu Trees

- * This key is not shown for an 8560E/EC with Option 002 installed and it is non-functional for Option 327.
- † The signal identification function is only available in non-preselected external mixing mode, with firmware revisions ≤ 920528 , or with Option 008 installed.
- ‡ This key is displayed only if unpreselected external mixing is selected (`EXT MXR PRE UNPR` is set to `UNPR`).
- § This key is displayed only if preselected external mixing is selected (`EXT MXR PRE UNPR` is set to `PRE`).
- || This key changes to `MARKER DELTA` if the marker delta function is active.

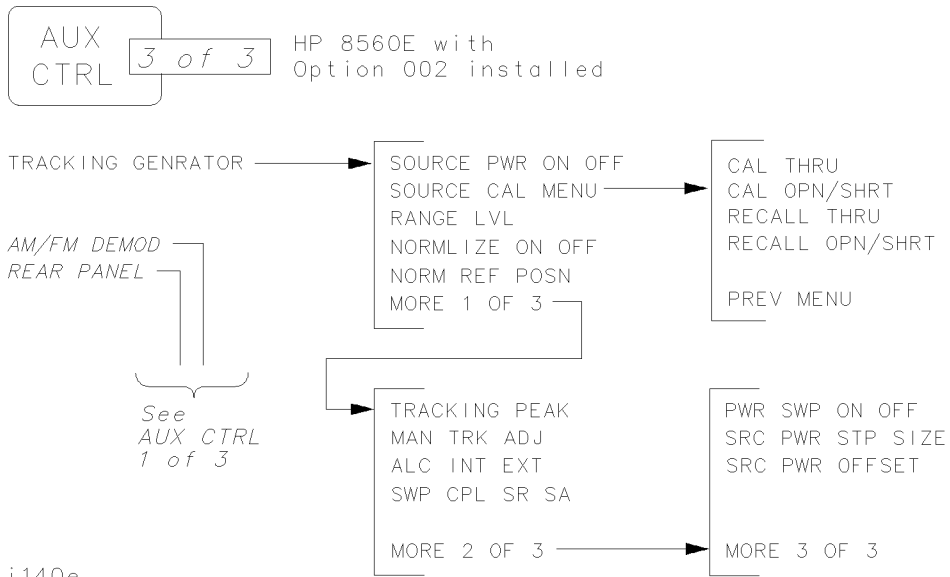

qj140e

BW

RES BW AUTO MAN
VIDEO BW AUTO MAN
VBW/RBW RATIO
RBW/SPAN RATIO
VID AVG ON OFF

qj19e

3-8 Menu Trees

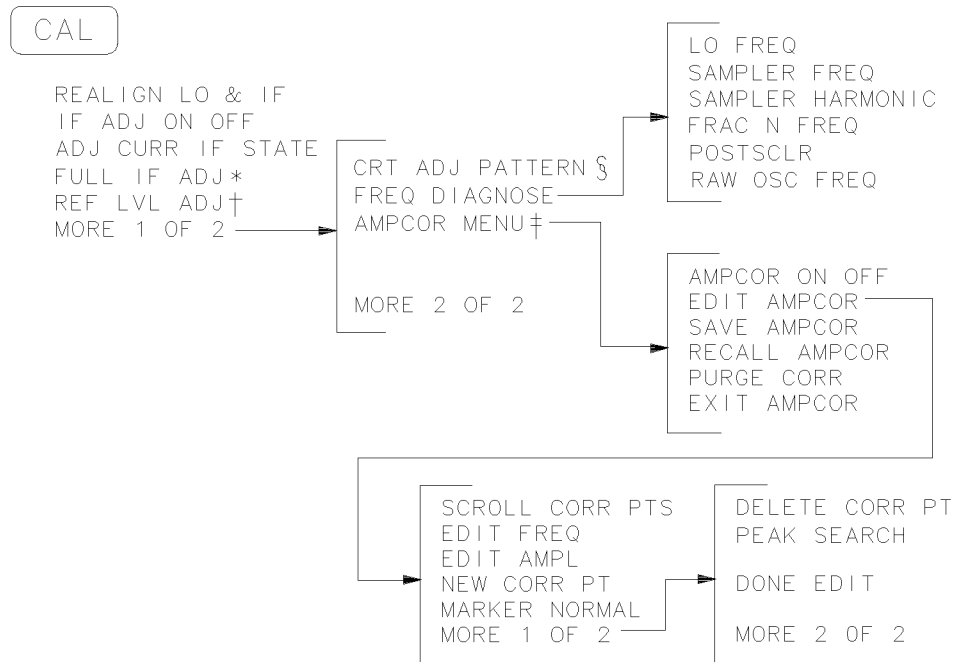

pj11c

- * Changes to **STOP ADJUST** if **FULL IF ADJ** is pressed.
- † Changes to **STORE REF LVL** if **REF LVL ADJ** is pressed.
- ‡ These functions are only available with firmware revisions >930809.
- § The CRT adjust pattern is used to help align the display of E-series instruments.

CONF I G

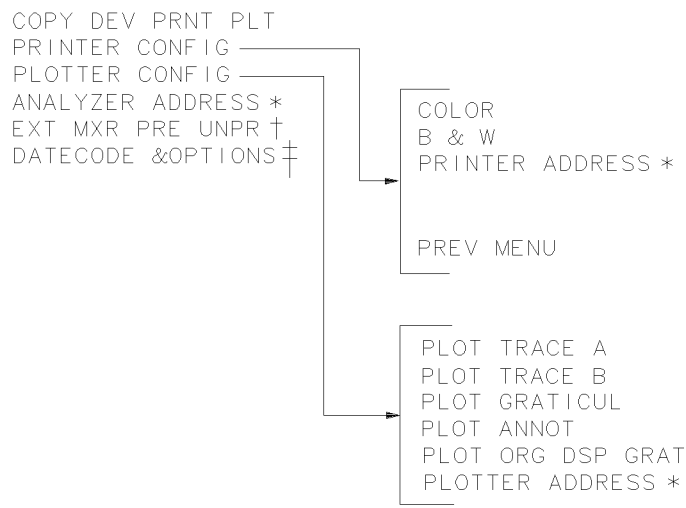

rj11c

- * Changes to **STORE GPIB ADR** if pressed.
- † Not available with Option 002 or Option 327.
- ‡ Both E-series and EC-series instruments appear as E-series in the instrument display when the DATECODE & OPTION key is pressed. EC-series instruments also appear as Option 007 instruments (Option 007 is the FADC option, which is standard in all EC-series instruments).

COPY

qj112e

3-10 Menu Trees

DISPLAY

DSPL LIN ON OFF
THRESHLD ON OFF
SCREEN TITLE

INTENSTY *
MORE 1 OF 2

SELECT CHAR
SPACE
BACK SPACE
ERASE TITLE
CHAR SET 1 2
TITLE DONE

GRAT ON OFF
ANNOT ON OFF
ANNOT HELP
FREQ DSP OFF
FOCUS †
MORE 2 OF 2

qj113e

- * Changes to **STORE INTENSTY** if **INTENSTY** is pressed. Note: 8560 EC-Series instruments do not require adjustment; therefore the intensity adjustment is not active for 8560 EC-Series instruments.
- † Changes to **STORE FOCUS** if **FOCUS** is pressed. Note: 8560 EC-Series instruments do not require adjustment; therefore the focus is not active for EC-Series instruments.

FREQ
COUNT

COUNTER ON OFF
COUNTER RES
MARKER NORMAL
MARKER DELTA
PEAK SEARCH
NEXT PEAK

qj114e

FREQUENCY

CENTER FREQ
START FREQ
STOP FREQ
CF STEP AUTO MAN
FREQ OFFSET
MORE 1 OF 2* →

CF/2 → CF
CF*2 → CF

MORE 2 OF 2

qj135e

* MORE 1 OF 2 is displayed under (FREQUENCY) only on spectrum analyzers with firmware revision 960401 and later.

HOLD

qj116e

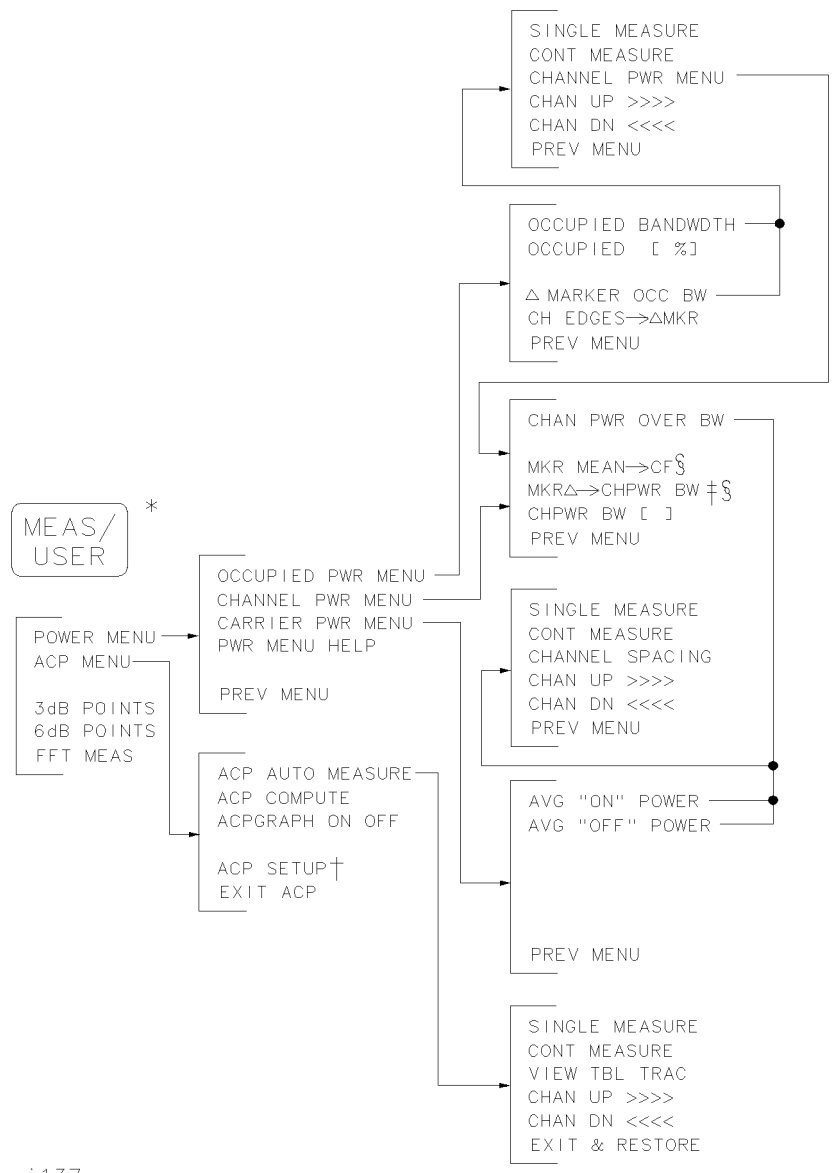

qj137e

3-14 Menu Trees

* Spectrum analyzers with firmware revisions ≤ 930809 have fewer power and adjacent channel power (ACP) functions.

† See the following figure for ACP setup menus.

‡ The **SPAN** softkey is displayed if the markers are not active.

§ Present only when this menu is accessed from the occupied power menu.

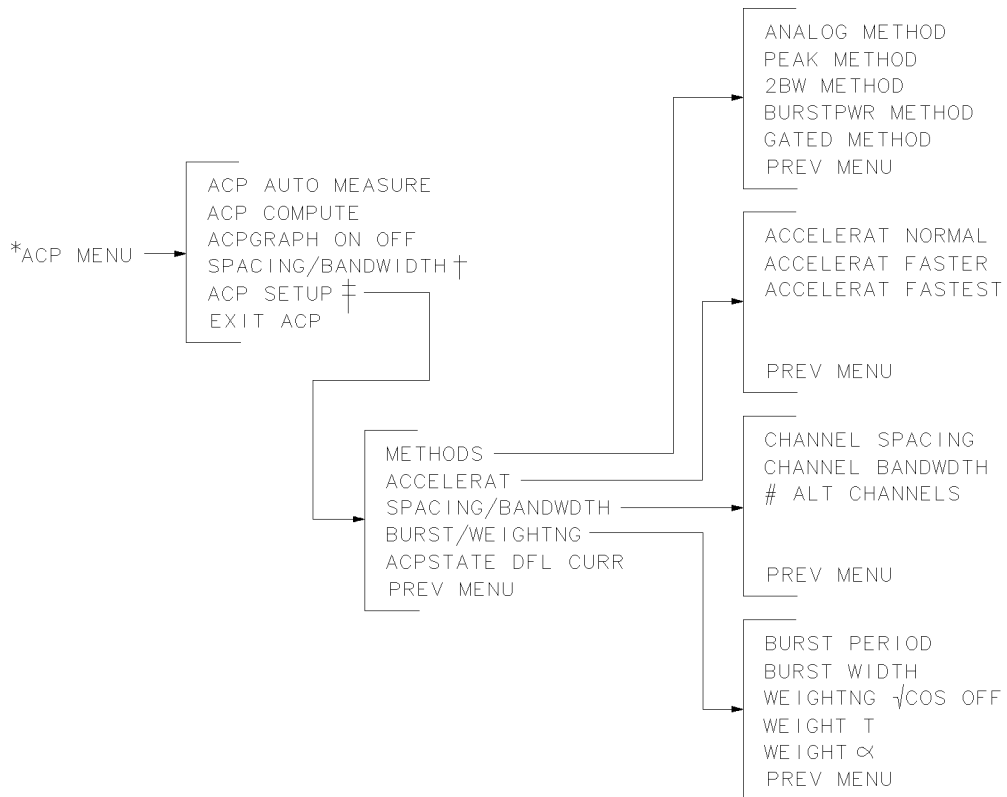

pj13e

* The **ACP MENU** softkey is under the **MEAS/USER** key. See the preceding figure.

† Available with firmware ≤ 930809 .

‡ Available with firmware > 931216 .

3-16 Menu Trees

MKR

MARKER NORMAL
MARKER DELTA
MARKER 1/DELTA
MKRNOISE ON OFF
SIG TRK ON OFF
MARKERS OFF

qj118e

MKR->

Normal Marker
Span > 0 Hz

MARKER -> CF
MARKER -> REF LVL
MARKER -> CF STEP

Normal Marker
Zero Span

MARKER -> REF LVL

Delta Marker
Span > 0 Hz

MKR Δ -> CF

MKR Δ -> CF STEP
MKR Δ -> SPAN

Delta Marker
Zero Span

MKR $1/\Delta$ -> CF

MKR $1/\Delta$ -> CF STEP

qj119e

MODULE *	MODULE †
USER KEYS TRACE SAVE/RCL LIMIT LINE AUTOEXEC MENU KEYDEF UTILITY	Test Adjust Diagnose Config EXIT MODULE

qj120e.

* **MODULE** accesses these additional softkeys if the 85620A mass memory module is attached to the spectrum analyzer. See the 85620A documentation for more information about these softkeys.

† **MODULE** accesses these additional softkeys if the 85629B test and adjustment module (TAM) is attached to the spectrum analyzer. See the 85629B documentation for more information about these softkeys. The 85629B is not compatible with the 8564E/EC or 8565E/EC.

Note The 8562E/TAM Interface Software is required when using the TAM with the 8562E spectrum analyzer.

PEAK
SEARCH

MARKER -> CF *
MARKER DELTA
NEXT PEAK
NEXT PK RIGHT
NEXT PK LEFT
MORE 1 OF 2

PEAK EXCURSN
PEAK THRESHLD

MORE 2 OF 2

.qj13e

* Changes to **MARKER NORMAL** if the spectrum analyzer is in zero span or **MARKER DELTA** is active.

PRESET

LAST STATE

.qj121e

RECALL

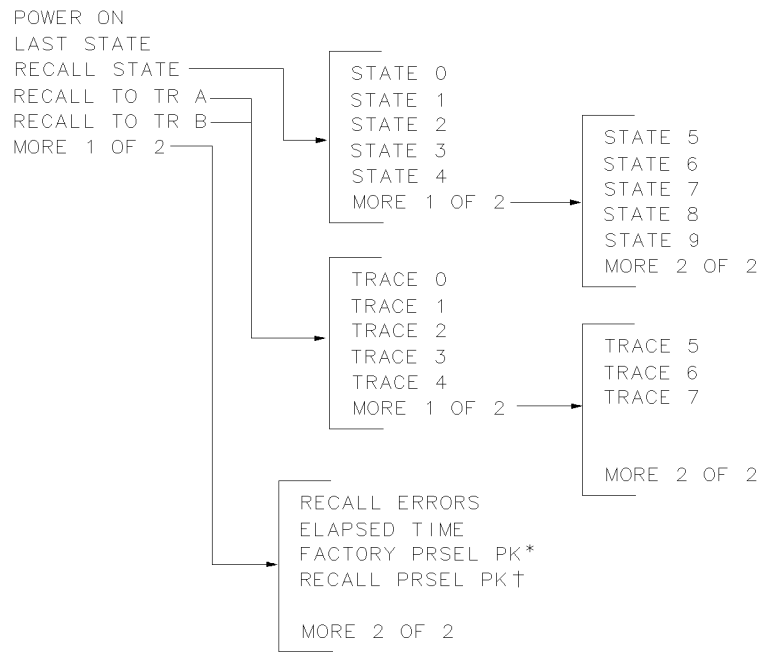

qj14e

* Available only with internal mixing above 2.9 GHz.

† Available with preselected external mixing. Available with internal mixing above 2.9 GHz.

SAVE

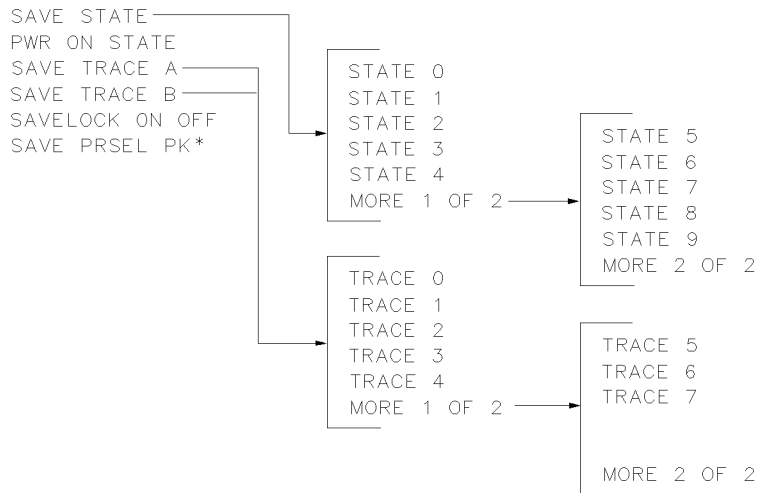

qj122e

* Available with preselected external mixing. Available with internal mixing above 2.9 GHz.

SGL
SWP

qj123e

SPAN

SPAN
SPAN ZOOM
FULL SPAN
ZERO SPAN
LAST SPAN

qj124e .

SWEEP

SWP TIME AUTO MAN
SWEEP CONT SGL
GATE ON OFF
GATED VIDEO
DLY SWP []
DLY SWP ON OFF

GATE DLY []*
GATE LEN []*
EDGE POL POS NEG †
GATE CTL EDGE LVL
PREV MENU

qj125e .

* This softkey is blanked if **GATE CTL EDGE LVL** is set to level (LVL).

† This softkey becomes **LVL POL POS NEG** if **GATE CTL EDGE LVL** is set to level (LVL).

3-22 Menu Trees

TRACE

CLEAR WRITE A
MAX HOLD A
VIEW A
BLANK A
TRACE A B
MORE 1 OF 3

VID AVG ON OFF
DETECTOR MODES
A EXCH B
NORMLIZE ON OFF
NORM REF POSN
MORE 2 OF 3

DETECTOR NORMAL
DETECTOR SAMPLE
DETECTOR POS PEAK
DETECTOR NEG PEAK
PREV MENU

A-B->A ON OFF
A+B->A
B-DL->B
A-B+DL->A ON OFF
MORE 3 OF 3

qj127e

TRIG

SWEEP CONT SGL
FREE RUN
VIDEO
LINE
EXTERNAL
TRIG POL POS NEG

qj126e

— |

| —

— |

| —

4

Front Panel Key Functions

This chapter lists the 8560 E-Series and 8560 EC-Series spectrum analyzer front-panel functions. The table in front indicates the front panel key used to find each softkey. If you know the front panel key, you can use the menu trees to locate the key.

After the table, every front panel key and softkey is listed. Next to each key label is a brief description of its operation. For more detailed descriptions of the keys, refer to the *Agilent Technologies 8560 E-Series and EC-Series Spectrum Analyzers User's Guide*.

Finding the Front Panel Key

Table 4-1. Front Panel Softkey Access

Softkey	Front Panel Access
ΔMARKER OCC BW	MEAS/USER
# ALT CHANNELS	MEAS/USER
0—10V LO SWP	AUX CTRL
.5 V/GHz (FAV)	AUX CTRL
10MHz EXT INT	AUX CTRL
2BW METHOD	MEAS/USER
3dB POINTS	MEAS/USER
6dB POINTS	MEAS/USER
A+B→A	TRACE
A-B→A ON OFF	TRACE
A-B+DL→A ON OFF	TRACE
A EXCH B	TRACE
ACCEL RAT	MEAS/USER
ACCEL RAT FASTER	MEAS/USER
ACCEL RAT FASTEST	MEAS/USER
ACCEL RAT NORMAL	MEAS/USER
ACP AUTO MEASURE	MEAS/USER
ACP COMPUTE	MEAS/USER
ACP MENU	MEAS/USER
ACP SETUP	MEAS/USER

4-2 Front Panel Key Functions

Table 4-1. Front Panel Softkey Access (continued)

Softkey	Front Panel Access
ACPGRAPH ON OFF	MEAS/USER
ACPSTATE DFL CURR	MEAS/USER
ADJ CURR IF STATE	CAL
AGC ON OFF	AUX CTRL
ALC INT EXT	AUX CTRL
ALL	AUTO COUPLE
AMPCOR MENU	CAL
AMPCOR ON OFF	CAL
ANALOG METHOD	MEAS/USER
ANNOT HELP	DISPLAY
ANNOT ON OFF	DISPLAY
AM DEMOD ON OFF	AUX CTRL
AM/FM DEMOD	AUX CTRL
AMPTD CORRECT	AUX CTRL
AMPTD UNITS	AMPLITUDE
ANALYZER ADDRESS	CONFIG
ATTEN AUTO MAN	AMPLITUDE, AUTO COUPLE
AVERAGE CNV LOSS	AUX CTRL
AVG "OFF" POWER	MEAS/USER
AVG "ON" POWER	MEAS/USER

Table 4-1. Front Panel Softkey Access (continued)

Softkey	Front Panel Access
B-DL→B	(TRACE)
B & W	(CONFIG)
BACK SPACE	(DISPLAY)
BIAS	(AUX CTRL)
BIAS OFF	(AUX CTRL)
BLANK A	(TRACE)
BLANK B	(TRACE)
BURST/WEIGHTNG	(MEAS/USER)
BURST WIDTH	(MEAS/USER)
BURST PERIOD	(MEAS/USER)
BURSTPWR METHOD	(MEAS/USER)
CAL OPN/SHRT	(AUX CTRL)
CAL THRU	(AUX CTRL)
CARRIER PWR MENU	(MEAS/USER)
CENTER FREQ	(FREQUENCY)
CF/2→CF	(FREQUENCY)
CF*2→CF	(FREQUENCY)
CF STEP AUTO MAN	(AUTO COUPLE), (FREQUENCY)
CH EDGES→ΔMKR	(MEAS/USER)
CH SPACG → ΔMKR	(MEAS/USER)

4-4 Front Panel Key Functions

Table 4-1. Front Panel Softkey Access (continued)

Softkey	Front Panel Access
CHAN DN <<<<	MEAS/USER
CHAN PWR OVER BW	MEAS/USER
CHAN UP >>>>	MEAS/USER
CHANNEL BANDWIDTH	MEAS/USER
CHANNEL PWR MENU	MEAS/USER
CHANNEL SPACING	MEAS/USER
CHAR SET 1 2	DISPLAY
CHPWR BW []	MEAS/USER
CLEAR WRITE A	TRACE
CLEAR WRITE B	TRACE
CNV LOSS VS FREQ	AUX CTRL
COLOR	CONFIG
CONT MEASURE	MEAS/USER
COPY DEV PRNT PLT	CONFIG
COUNTER ON OFF	FREQ COUNT
COUNTER RES	FREQ COUNT
COUPLING AC DC	AMPLITUDE
CRT ADJ PATTERN	CAL

Table 4-1. Front Panel Softkey Access (continued)

Softkey	Front Panel Access
DATECODE & OPTIONS	CONFIG
dBm	AMPLITUDE
dB μ V	AMPLITUDE
dBmV	AMPLITUDE
DELETE CORR PT	CAL
DEMOD TIME	AUX CTRL
DETECTOR MODES	TRACE
DETECTOR NEG PEAK	TRACE
DETECTOR NORMAL	TRACE
DETECTOR POS PEAK	TRACE
DETECTOR SAMPLE	TRACE
DLY SWP []	SWEEP
DLY SWP ON OFF	SWEEP
DONE EDIT	CAL
DSPL LIN ON OFF	DISPLAY
EDGE POL POS NEG	SWEEP
EDIT AMPCOR	CAL
EDIT AMPL	CAL
EDIT FREQ	CAL
ELAPSED TIME	RECALL
ERASE TITLE	DISPLAY

4-6 Front Panel Key Functions

Table 4-1. Front Panel Softkey Access (continued)

Softkey	Front Panel Access
EXIT & RESTORE	MEAS/USER
EXIT ACP	MEAS/USER
EXIT AMPCOR	CAL
EXT MXR PRE UNPR	CONFIG
EXTERNAL	TRIG
EXTERNAL MIXER	AUX CTRL
FACTORY PRSEL PK	AUX CTRL
FFT MEAS	MEAS/USER
FM DEMOD ON OFF	AUX CTRL
FOCUS	DISPLAY
FRAC N FREQ	CAL
FREE RUN	TRIG
FREQ DIAGNOSE	CAL
FREQ DSP OFF	DISPLAY
FREQ OFFSET	FREQUENCY
FULL BAND	AUX CTRL
FULL IF ADJ	CAL
FULL SPAN	SPAN
GATE CTL EDGE LVL	SWEEP
GATE DLY []	SWEEP
GATE LEN []	SWEEP
GATE ON OFF	SWEEP

Table 4-1. Front Panel Softkey Access (continued)

Softkey	Front Panel Access
GATED METHOD	(MEAS/USER)
GATED VIDEO	(SWEEP)
GRAT ON OFF	(DISPLAY)
IF ADJ ON OFF	(CAL)
INTENSTY	(DISPLAY)
INTERNAL MIXER	(AUX CTRL)
LAST SPAN	(SPAN)
LAST STATE	(PRESET), (RECALL)
LINE	(TRIG)
LINEAR	(AMPLITUDE)
LO FREQ	(CAL)
LOCK HARMONIC	(AUX CTRL)
LOCK ON OFF	(AUX CTRL)
LOG dB/DIV	(AMPLITUDE)
LVL POL POS NEG	(SWEEP)
MAN TRK ADJ	(AUX CTRL)
MARKER → CF	(MKR→), (PEAK SEARCH)
MARKER → CF STEP	(MKR→)
MARKER → REF LVL	(MKR→)

4-8 Front Panel Key Functions

Table 4-1. Front Panel Softkey Access (continued)

Softkey	Front Panel Access
MARKER 1/DELTA	(MKR)
MARKER DELTA	(FREQ COUNT), (MKR), (PEAK SEARCH), (AUX CTRL)
MARKER NORMAL	(AUX CTRL), (FREQ COUNT), (MKR), (CAL)
MARKERS OFF	(MKR)
MAX HOLD A	(TRACE)
MAX HOLD B	(TRACE)
MAX MXR LEVEL	(AMPLITUDE)
METHODS	(MEAS/USER)
MKR Δ \rightarrow CF	(MKR \rightarrow)
MKR Δ \rightarrow CF STEP	(MKR \rightarrow)
MKR Δ \rightarrow CHPWR BW	(MEAS/USER)
MKR Δ \rightarrow SPAN	(MKR \rightarrow)
MKR 1/ Δ \rightarrow CF	(MKR \rightarrow)
MKR 1/ Δ \rightarrow CF STEP	(MKR \rightarrow)
MKR MEAN \rightarrow CF	(MEAS/USER)
MKRNOISE ON OFF	(MKR)
NEGATIVE BIAS	(AUX CTRL)
NEW CORR PT	(CAL)

Table 4-1. Front Panel Softkey Access (continued)

Softkey	Front Panel Access
NEXT PEAK	(AUX CTRL), (FREQ COUNT), (PEAK SEARCH)
NEXT PK LEFT	(PEAK SEARCH)
NEXT PK RIGHT	(PEAK SEARCH)
NORM REF LVL	(AMPLITUDE)
NORM REF POSN	(AMPLITUDE), (AUX CTRL), (TRACE)
NORMALIZE ON OFF	(AUX CTRL), (TRACE)
OCCUPIED [%]	(MEAS/USER)
OCCUPIED BANDWIDTH	(MEAS/USER)
OCCUPIED PWR MENU	(MEAS/USER)
PEAK EXCURSN	(PEAK SEARCH)
PEAK METHOD	(MEAS/USER)
PEAK SEARCH	(AUX CTRL), (FREQ COUNT), (CAL)
PEAK THRESHLD	(PEAK SEARCH)
PLOT ANNOT	(CONFIG)
PLOT GRATICUL	(CONFIG)
PLOT ORG DSP GRAT	(CONFIG)
PLOT TRACE A	(CONFIG)
PLOT TRACE B	(CONFIG)
PLOTTER ADDRESS	(CONFIG)
PLOTTER CONFIG	(CONFIG)
POSITIVE BIAS	(AUX CTRL)
POSTSCLR	(CAL)

4-10 Front Panel Key Functions

Table 4-1. Front Panel Softkey Access (continued)

Softkey	Front Panel Access
POWER MENU	(MEAS/USER)
POWER ON	(RECALL)
PRESEL AUTO PK	(AMPLITUDE), (AUX CTRL)
PRESEL MAN ADJ	(AMPLITUDE), (AUX CTRL)
PRESEL PEAK	(AUX CTRL)
PRINTER ADDRESS	(CONFIG)
PRINTER CONFIG	(CONFIG)
PURGE CORR	(CAL)
PWR ON STATE	(SAVE)
PWR MENU HELP	(MEAS/USER)
PWR SWP ON OFF	(AUX CTRL)
RANGE LVL	(AMPLITUDE), (AUX CTRL)
RAW OSC FREQ	(CAL)
RBW/SPAN RATIO	(BW)
REALIGN LO & IF	(CAL)
REAR PANEL	(AUX CTRL)
RECALL AMPCOR	(CAL)
RECALL ERRORS	(RECALL)
RECALL OPN/SHRT	(AUX CTRL)
RECALL PRESEL PK	(RECALL)

Table 4-1. Front Panel Softkey Access (continued)

Softkey	Front Panel Access
RECALL STATE	(RECALL)
RECALL THRU	(AUX CTRL)
RECALL TO TR A	(RECALL)
RECALL TO TR B	(RECALL)
REF LVL	(AMPLITUDE)
REF LVL ADJ	(CAL)
REF LVL OFFSET	(AMPLITUDE)
RES BW AUTO MAN	(AUTO COUPLE), (BW)
SAMPLER FREQ	(CAL)
SAMPLER HARMONIC	(CAL)
SAVE AMPCOR	(CAL)
SAVE PRSEL PK	(SAVE)
SAVE STATE	(SAVE)
SAVE TRACE A	(SAVE)
SAVE TRACE B	(SAVE)
SAVELOCK ON OFF	(SAVE)
SCREEN TITLE	(DISPLAY)
SCROLL CORR PTS	(CAL)
SELECT CHAR	(DISPLAY)

4-12 Front Panel Key Functions

Table 4-1. Front Panel Softkey Access (continued)

Softkey	Front Panel Access
SIG ID → CF	(AUX CTRL)
SIG ID AT MKR	(AUX CTRL)
SIG ID ON OFF	(AUX CTRL)
SIG TRK ON OFF	(MKR)
SIGNAL IDENT	(AUX CTRL)
SINGLE MEASURE	(MEAS/USER)
SOFTKEY 1 thru SOFTKEY 5	(CAL)
SOURCE CAL MENU	(AUX CTRL)
SPACE	(DISPLAY)
SPACING/BANDWIDTH	(MEAS/USER)
SPAN	(SPAN)
SPAN ZOOM	(SPAN)
SQUELCH ON OFF	(AUX CTRL)
SRC PWR OFFSET	(AUX CTRL)
SRC PWR ON OFF	(AUX CTRL)
SRC PWR STP SIZE	(AUX CTRL)
START FREQ	(FREQUENCY)
STATE 0 thru STATE 9	(RECALL), (SAVE)
STOP FREQ	(FREQUENCY)
SWEEP CONT SGL	(SWEEP), (TRIG)
SWP CPL SR SA	(AUX CTRL)
SWP TIME AUTO MAN	(AUTO COUPLE), (SWEEP)

Table 4-1. Front Panel Softkey Access (continued)

Softkey	Front Panel Access
THRESHLD ON OFF	(DISPLAY)
TITLE DONE	(DISPLAY)
TRACE 0 thru TRACE 7	(RECALL), (SAVE)
TRACE A B	(TRACE)
TRACKING GENRATOR	(AUX CTRL)
TRACKING PEAK	(AUX CTRL)
TRIG POL POS NEG	(TRIG)
UNITS AUTO MAN	(AMPLITUDE), (AUTO COUPLE)
VBW/RBW RATIO	(BW)
V/GHz .25 .50	(AUX CTRL)
VIEW A	(TRACE)
VIEW B	(TRACE)
VIEW TBL TRCE	(MEAS/USER)
VID AVG ON OFF	(BW), (TRACE)
VIDEO	(TRIG)
VIDEO BW AUTO MAN	(AUTO COUPLE), (BW)
VOLTS	(AMPLITUDE)
WATTS	(AMPLITUDE)
WEIGHT α	(MEAS/USER)
WEIGHT T	(MEAS/USER)
WEIGHTING $\sqrt{\text{COS}}$ OFF	(MEAS/USER)
ZERO SPAN	(SPAN)

4-14 Front Panel Key Functions

Key Descriptions

# ALT CHANNELS	Selects the number of pairs of alternate channels for an ACP measurement.
ΔMARKER OCC BW	Calculates the occupied power bandwidth with respect to the power between the markers.
0→10V LO SWP	Selects the 0 to 10 V ramp for J8 on the rear panel. The 0 to 10 V ramp corresponds to the sweep ramp that tunes the local oscillator.
.5 V/GHz (FAV)	Selects a 0.5 V per GHz sweep output for J8 on the rear panel. This is the frequency-analog voltage (FAV). It is primarily used with external tracking generators.
2BW METHOD	Makes an ACP measurement using two different resolution bandwidths.
3dB POINTS	A peak search is performed and the 3 dB bandwidth of the largest signal on-screen is displayed in the active function area.
6dB POINTS	A peak search is performed and the 6 dB bandwidth of the largest signal on-screen is displayed in the active function area.
10 MHz EXT INT	Selects an external (EXT) or internal (INT) frequency reference.
A+B→A	Adds the contents of trace A to those of trace B and places the result in trace A.
A-B→A ON OFF	When on, this function continuously subtracts the contents of trace B from those of trace A, and places the result in trace A.

A-B+DL-A ON OFF

When on, this function continuously subtracts the contents of trace B from those of trace A, adds the display line to the result, then places the final result in trace A.

A EXCH B

Exchanges the contents of trace A with those of trace B, then places traces A and B in view mode.

ACCEL RAT

Accelerates the adjacent channel power measurement.

ACCEL RAT FASTER

Accelerates the ACP measurement with minimal effects on accuracy.

ACCEL RAT FASTEST

Accelerates the ACP measurement, but affects the accuracy by as much as 2 dB.

ACCEL RAT NORMAL

Makes the ACP measurement as specified by the standards.

ACP AUTO MEASURE

Measures the power that “leaks” from the transmitter output into the channels that are adjacent to the carrier.

ACP COMPUTE

Performs an adjacent channel power (ACP) computation on the current trace data without changing the instrument state settings.

ACP MENU

Accesses the adjacent channel power (ACP) menu of softkeys that measure the adjacent channel power ratio of a transmitter.

ACP SETUP

Accesses the ACP setup functions. Many different measurement parameters can be set from this menu. Some of the parameters are interactive; changing one parameter can change, add, or delete other parameters.

ACPGRAPH ON OFF

Displays a graphical representation of the adjacent power channel power (ACP) ratio, for the selected channel bandwidth, as a function of the channel spacing.

4-16 Front Panel Key Functions

ACPSTATE DFL CURR	Selects the default state for measuring adjacent channel power, or allows you to create a current state.
ADJ CURR IF STATE	Adjusts various parameters in the IF for the bandwidth currently in use, producing optimum amplitude accuracy.
AGC ON OFF	Switches automatic gain control on or off and keeps the volume relatively constant during AM demodulation.
ALC INT EXT	Selects internal or external leveling, which improves the amplitude accuracy of tracking generator measurements. <i>Available with an 8560E/EC Option 002 only.</i>
ALL	Couples all “AUTO” functions: resolution bandwidth, video bandwidth, sweep time, input attenuation, center frequency step-size, and amplitude units.
AM DEMOD ON OFF	Turns AM demodulation on and off.
AM/FM DEMOD	Accesses functions for AM or FM demodulation.
AMPCOR MENU	Accesses functions that allow you to enter amplitude correction (ampcor) factors to correct system flatness.
AMPCOR ON OFF	Turns the amplitude correction factors on and off.
AMPLITUDE	Activates the reference level function and accesses a menu of amplitude related functions.
AMPTD CORRECT	Accesses functions that set conversion loss and flatness data for external mixer measurements. <i>Not available with an 8560E/EC Option 002.</i>
AMPTD UNITS	Accesses the softkeys that allow you to change the amplitude units of the spectrum analyzer.
ANALOG METHOD	Makes adjacent channel power (ACP) measurements, usually of continuous signals, by measuring power

	versus frequency and integrating the result over the channel bandwidth.
ANALYZER ADDRESS	Displays the current GPIB address of the spectrum analyzer, which can be changed, entered, and then stored using STORE GPIB .
ANNOT HELP	Displays descriptions of the annunciators that appear on the left-hand side of the screen indicating which functions are turned on or off.
ANNOT ON OFF	Switches the display annotation on and off.
ATTEN AUTO MAN	Sets the input attenuator, so that it is either coupled to the reference level (AUTO) or adjusted manually (MAN). <i>Internal mixing only.</i>
AUTO COUPLE	Accesses a menu of coupled-mode functions.
AUX CTRL	Accesses a menu of tracking generator, internal mixer, external mixer, demodulation, and rear-panel functions.
AVERAGE CNV LOSS	Displays the mean conversion loss for the current harmonic and allows you to enter new conversion loss data. Any change to the average conversion loss also affects flatness data. <i>Not available with an 8560E/EC Option 002 and non-functional in Option 327.</i>
AVG "OFF" POWER	Measures the power of the carrier when the burst is off.
AVG "ON" POWER	Measures the power of the carrier when the burst is on.
B-DL→B	Subtracts the display-line value from the contents of trace B, then places the result in trace B.
B & W	Selects a monochromatic printer configuration for use with COPY .
BACK SPACE	Deletes the last character placed in the current title.
BIAS	Displays a menu of functions for selecting unpreselected external-mixer bias. <i>Unpreselected</i>

4-18 Front Panel Key Functions

	<i>external mixing only, and not available with an 8560E/EC Option 002; non-functional in Option 327.</i>
BIAS OFF	Turns external-mixer bias off. <i>Not available with an 8560E/EC Option 002 and non-functional in Option 327.</i>
BLANK A	Blanks the contents of trace A from the display.
BLANK B	Blanks the contents of trace B from the display.
BURST/WEIGHTNG	Accesses functions that allow you to change the burst width and period for ACP measurements.
BURST PERIOD	Sets the burst period for ACP measurements.
BURST WIDTH	Sets the burst width for ACP measurements.
BURSTPWR METHOD	Makes adjacent channel power (ACP) measurements on burst signals.
BW	Accesses the menu of bandwidth related functions.
CAL	Accesses the menu of calibration functions.
CAL OPN/SHRT	Measures and computes the average of an open- and a short-input calibration, then stores the data in trace B and in instrument state register 8. Use when making reflection measurements with a tracking generator.
CAL THRU	Stores thru calibration in trace B and in instrument state register 9. Use when making transmission measurements with a tracking generator.
CARRIER PWR MENU	Accesses carrier power measurement functions.
CENTER FREQ	Activates the center frequency function and sets the spectrum analyzer to center frequency span mode.
CF/2→CF	Sets the center frequency of the spectrum analyzer to the currently-displayed center frequency divided by two.
CF*2→CF	Sets the center frequency of the spectrum analyzer to the currently-displayed center frequency times two.

CF STEP AUTO MAN	Adjusts the center frequency step size so that when a step key is pressed, the center frequency shifts by the selected step size. This function may be coupled to the frequency span function (AUTO), or set manually (MAN).
CH EDGES—ΔMKR	Moves the marker locations to the channel edges, for an occupied power measurement.
CHAN DN <<<<	Moves the center frequency down (lower) by one channel spacing.
CHAN PWR OVER BW	Calculates the power in the channel by integrating over the channel bandwidth.
CHAN UP >>>>	Moves the center frequency up (higher) by one channel spacing.
CHANNEL BANDWIDTH	Sets the channel bandwidth for an adjacent channel power (ACP) measurement.
CHANNEL PWR MENU	Accesses the channel power measurement functions.
CHANNEL SPACING	Sets the spacing between channels for an adjacent channel power (ACP) measurement.
CHAR SET 1 2	Accesses character sets used for creating titles.
CHPWR BW []	Sets the channel bandwidth for a channel power measurement. See CHAN PWR OVER BW .
CLEAR WRITE A	Clears trace A and sets it to accept and display new input-signal data continuously.
CLEAR WRITE B	Clears trace B and sets it to accept and display new input-signal data continuously.
CNV LOSS VS FREQ	Displays the conversion loss for a specific frequency in the current band. For use with external mixers; see Table 4-2. <i>Not available with an 8560E/EC Option 002 and non-functional in Option 327.</i>

4-20 Front Panel Key Functions

Table 4-2. Conversion-Loss Flatness Data

Band	Frequency Range	Number of Flatness Points	Point Spacing	Conversion Loss
K	18.6—26.5 GHz	6	2 GHz	30 dB
A	26.5—40.0 GHz	8	2 GHz	30 dB
Q	33.0—50.0 GHz	7	3 GHz	30 dB
U	40.0—60.0 GHz	6	4 GHz	30 dB
V	50.0—75.0 GHz	6	5 GHz	30 dB
E	60.0—90.0 GHz	7	5 GHz	30 dB
W	75.5—110.0 GHz	8	5 GHz	30 dB
F	90.0—140.0 GHz	6	10 GHz	30 dB
D	110.0—170.0 GHz	7	10 GHz	30 dB
G	140.0—220.0 GHz	9	10 GHz	30 dB
Y	170.0—260.0 GHz	7	15 GHz	30 dB
J	220.0—325.0 GHz	8	15 GHz	30 dB

COLOR

Selects the HP PaintJet or compatible color printer configuration for use with **COPY**.

CONFIG

Accesses a menu of functions used to configure a plotter and a printer as hard-copy devices, sets the spectrum analyzer GPIB address, and views the instrument datecode and options.

CONT MEASURE

Sets the measurements so that they run continuously.

COPY

Copies the display contents onto a plotter or a printer.

COPY DEV PRNT PLT

Selects a printer or a plotter as the hard-copy device used with **COPY**.

COUNTER ON OFF

Switches the precision frequency counter ON and OFF (activating a marker if none is present), and displays counter results when the counter is on.

COUNTER RES

Adjusts the resolution of the frequency counter readout.

COUPLING AC DC

Selects ac or dc coupling to the input; ac coupling protects the input of the analyzer from damaging dc signals. Not available in the 8563E, 8564E, and 8565E.

CRT ADJ PATTERN

Displays an alignment pattern which is used in conjunction with the X POSN, Y POSN, and TRACE ALIGN adjustments (located on the rear panel) that are available on 8560 E-Series instruments. Note: 8560 EC-Series instruments use a flat-panel display which does not require adjustment, and is not adjustable.

DATECODE & OPTIONS

Displays the analyzer firmware datecode, its instrument serial number, its model number, and any options present. Note that both E-series and EC-series instruments will appear as E-series instruments in the display when this key is pressed. EC-series instruments also appear as Option 007 instruments (Option 007 is the FADC option, which is standard in all EC-series instruments).

dB μ V

Selects absolute decibels relative to 1 microvolt as the amplitude units.

dBm

Selects absolute decibels relative to 1 milliwatt as the amplitude units.

dBmV

Selects absolute decibels relative to 1 millivolt as the amplitude units.

DELETE CORR PT

Ampcor function which deletes a single correction point.

DEMOD TIME

Selects the duration of demodulation between successive sweeps.

DETECTOR MODES

Accesses a menu of detector modes.

DETECTOR NEG PEAK

Selects negative-peak detection of the video signal.

DETECTOR NORMAL

The normal-detector mode alternately displays positive and negative peaks when the presence

4-22 Front Panel Key Functions

	of noise is detected, and displays positive peaks otherwise.
DETECTOR POS PEAK	Selects positive-peak detection of the video signal.
DETECTOR SAMPLE	Samples the video signal.
DISPLAY	Accesses a menu of display-related functions.
DLY SWP []	Delays the start of the sweep until the specified time elapses after the trigger event (or before with Option 007.)
DLY SWP ON OFF	Turns the delayed sweep function on and off. This function delays the start of the sweep until after the trigger event. With Option 007, the sweep can be started before the trigger event.
DONE EDIT	Exits the ampcor menu that is used for editing correction points.
DSPL LIN ON OFF	Switches the display line on and off.
EDGE POL POS NEG	Selects the polarity for edge triggering of a gated measurement.
EDIT AMPCOR	Allows you to edit the ampcor correction points.
EDIT AMPL	Allows you to edit the amplitude of an ampcor correction point.
EDIT FREQ	Allows you to edit the frequency of an ampcor correction point.
ELAPSED TIME	Displays the cumulative operating time of the spectrum analyzer.
ERASE TITLE	Erases the current title from the display.
EXIT & RESTORE	Exits the ACP menu turning off the function and restoring the previous spectrum analyzer state.
EXIT ACP	Exits the adjacent channel power measurement (ACP) menu.
EXIT AMPCOR	Exits the amplitude correction menu.

EXTERNAL	Sets the trigger to external mode. Connect an external trigger source to J5 (EXT/GATE TRIG INPUT) on the rear panel.
EXTERNAL MIXER	Accesses a menu of external-mixer functions. <i>Not available with an 8560E/EC Option 002 and non-functional in Option 327.</i>
EXT MXR PRE UNPR	Selects either preselected or unpreselected external mixing mode. <i>Not available with an 8560E/EC Option 002 and non-functional in Option 327.</i>
FACTORY PRSEL PK	Restores the factory preselector-peaking data as the current preselector data. <i>Only with internal mixing above 2.9 GHz.</i>
FFT MEAS	Performs a discrete Fourier transform on the input signal, converting zero-span information into the frequency domain.
FM DEMOD ON OFF	Switches FM demodulation ON and OFF.
FOCUS	Permits focusing of the display for 8560 E-Series instruments, using the data keys, the step keys, or the knob. Note: 8560 EC-Series instruments use a flat-panel display which does not require adjustment, and is not adjustable..
FRAC N FREQ	Displays the fractional N frequency corresponding to the current start frequency.
FREE RUN	Sets the trigger to free-run mode; sweep triggers occur as rapidly as the spectrum analyzer will allow.
FREQ COUNT	Turns the frequency counter on (activates a marker if none is present) and accesses a menu of counter and marker functions.
FREQ DIAGNOSE	Accesses a menu of diagnostic functions which allow various internal parameters to be displayed.
FREQ DSP OFF	Turns off all frequency related annotation. Press PRESET to restore annotation.

4-24 Front Panel Key Functions

FREQ OFFSET

Adds an offset value to displayed frequency values, including marker frequency values. The range of the sweep (that is, the span) is not affected.

FREQUENCY

Activates the center frequency (or the start frequency) and accesses a menu of frequency functions.

FULL BAND

Selects commonly-used frequency bands above 18 GHz and activates the harmonic-lock function. See Table 4-3. *Not available with an 8560E/EC Option 002.*

**Table 4-3.
External Mixing Frequency Bands and
Recommended Harmonics (For Unpreselected
External Mixers)**

Band	Frequency Range	Mixing Harmonic	Conversion Loss
K	18.6—26.5 GHz	6—	30 dB
A	26.5—40.0 GHz	8—	30 dB
Q	33.0—50.0 GHz	10—	30 dB
U	40.0—60.0 GHz	10—	30 dB
V	50.0—75.0 GHz	14—	30 dB
E	60.0—90.0 GHz	16—	30 dB
W	75.5—110.0 GHz	18—	30 dB
F	90.0—140.0 GHz	24—	30 dB
D	110.0—170.0 GHz	30—	30 dB
G	140.0—220.0 GHz	36—	30 dB
Y	170.0—260.0 GHz	44—	30 dB
J	220.0—325.0 GHz	54—	30 dB

FULL IF ADJ

Executes a complete adjustment of the IF system for optimum measurement accuracy.

FULL SPAN

Sets the spectrum analyzer span to its maximum frequency range.

GATE CTL EDGE LVL	Selects the use of edge triggering or level triggering to control the gate.
GATE DLY []	Controls the length of time from the trigger until the gate is turned on.
GATE LEN []	Controls the length of time that the gate is on when using edge triggering.
GATE ON OFF	Turns the gate function on and off.
GATED METHOD	Makes adjacent channel power (ACP) measurements using time gating techniques.
GATED VIDEO	Accesses the menu of functions for setting gate parameters.
GRAT ON OFF	Turns the display graticule on and off.
HOLD	Holds the active function to its present value, blanks the softkeys and active function area from the display, and expands the remaining graticule and annotation.
IF ADJ ON OFF	Switches the automatic IF adjustment on and OFF. When it is on, various IF parameters are adjusted during retrace to ensure amplitude accuracy within specifications.
INTENSTY	Permits changing the display intensity of 8560 E-Series instruments using the data keys, step keys, or the knob. Note: 8560 EC-Series instruments use a flat-panel display which does not require adjustment, and is not adjustable.
INTERNAL MIXER	Accesses a menu of signal-identification functions or returns the spectrum analyzer from external-mixer mode to its internal frequency coverage. <i>Not available with Option 002 and non-functional in Option 327.</i>
LAST SPAN	Sets the spectrum analyzer to the previously-selected span.

4-26 Front Panel Key Functions

LAST STATE	Recalls the state that existed before preset was pressed or power was turned off.
LINE	Sets the trigger to line mode; sweep triggers occur at intervals synchronized to the line frequency.
LINEAR	Selects the linear amplitude scale.
LOCK HARMONIC	Displays the number of the harmonic currently used to sweep the selected external mixing frequency band. Only frequencies and spans that fall within the frequency band of the current harmonic may be entered. See Table 4-3. <i>Not available with Option 002 and non-functional in Option 327.</i>
LOCK ON OFF	Turns the harmonic lock on and off. When it is on, it performs the same function as LOCK HARMONIC . <i>Not available with Option 002 and non-functional in Option 327.</i>
LO FREQ	Displays the first local oscillator frequency corresponding to the current start frequency.
LOG dB/DIV	Selects a 1, 2, 5, or 10 dB per division logarithmic amplitude scale.
LVL POL POS NEG	Selects the polarity for turning the gate on when using level triggering for a gated measurement.
MAN TRK ADJ	Permits manual adjustment of the tracking generator oscillator using the data keys, the step keys, or the knob. <i>8560E/EC Option 002 only.</i>
MARKER→CF	Sets center frequency equal to the marker frequency.
MARKER→CF STEP	Sets the center frequency step size equal to the marker frequency. The step keys change the center frequency in increments equal to the step size.
MARKER→REF LVL	Sets the reference level equal to the amplitude of the marker.

MARKER 1/DELTA	Sets the marker readout to a frequency equal to the reciprocal of the delta value. Used in zero span mode.
MARKER DELTA	Reads the difference in amplitude and in frequency (or time when the span equals 0 Hz) and displays these values.
MARKER NORMAL	Activates a single marker and places it at the center of the trace.
MARKERS OFF	Turns all markers off and blanks the softkey menu.
MAX HOLD A	Displays and holds the maximum responses of the input signal in trace A.
MAX HOLD B	Displays and holds the maximum responses of the input signal in trace B.
MAX MXR LEVEL	Selects the maximum mixer level seen at the input mixer for signals at or below the reference level. <i>Internal mixing only.</i>
MEAS/USER	Accesses softkeys that perform occupied power bandwidth, adjacent channel power (ACP), and FFT measurements.
METHODS	Selects the measurement method that will be used to make the adjacent channel power measurement.
MKR	Activates a marker and accesses a menu of marker functions.
MKR→	Activates a marker and accesses a menu of “marker-to” functions.
MKR Δ→CF	Sets the center frequency equal to the delta frequency value.
MKR Δ→CF STEP	Sets the center frequency step size equal to the delta frequency value.
MKR Δ→CHPWR BW	Sets the channel power bandwidth parameter to the value of the difference between the two markers.

4-28 Front Panel Key Functions

MKR Δ —SPAN	Sets the start and stop frequencies equal to the frequencies of the two markers.
MKR $1/\Delta$ —CF	Sets the center frequency equal to the reciprocal of the delta value. For use in zero span mode.
MKR $1/\Delta$ —CF STEP	Sets the center frequency step size equal to the reciprocal of the delta value. For use in zero span mode.
MKR MEAN \rightarrow CF	Moves the midpoint of the two displayed markers to the center frequency.
MKRNOISE ON OFF	Turns the marker noise function on or off. When it is on, it normalizes the equivalent amplitude of the measured noise to a 1 Hz bandwidth. Not for use with tracking generators.
MODULE	Accesses the functions of an optional rear-panel module, when it is present.
NEGATIVE BIAS	Selects negative bias for an external mixer. <i>Not available with a 8560E Option 002 and non-functional in Option 327.</i>
NEW CORR PT	Allows you to create a new ampcor correction point.
NEXT PEAK	Moves the active marker to the next-highest trace peak relative to the current marker position.
NEXT PK LEFT	Finds the next peak to the left of the current marker position.
NEXT PK RIGHT	Finds the next peak to the right of the current marker position.
NORM REF LVL	Activates the normalized reference level, permitting an offset to be introduced to the displayed trace. For use with NORMLIZE ON OFF .
NORM REF POSN	Adjusts the normalized reference position. For use with NORMLIZE ON OFF .

<code>NORMLIZE ON OFF</code>	Switches the normalization routine, for stimulus-response measurements, on and off.
<code>OCCUPIED [%]</code>	Enters the desired percentage of occupied power for an occupied bandwidth measurement.
<code>OCCUPIED BANDWDTH</code>	Integrates the power displayed and returns the bandwidth containing the selected percent of the total displayed power.
<code>OCCUPIED PWR MENU</code>	Accesses the occupied power bandwidth functions.
<code>PEAK EXCURSN</code>	Defines what constitutes a peak on a trace. The selected value specifies the amount that a trace must increase monotonically, then decrease monotonically in order to be a peak.
<code>PEAK METHOD</code>	Makes adjacent channel power (ACP) measurements using peak power integration.
<code>PEAK SEARCH</code>	Places a marker at the highest point on a trace and accesses a menu of marker functions.
<code>PEAK SEARCH</code>	Places a marker on the highest point on a trace and displays the marker frequency and amplitude.
<code>PEAK THRESHLD</code>	Sets the minimum amplitude level from which a peak on a trace can be detected.
<code>PLOT ANNOT</code>	Plots only the display annotation. To halt plotting before it is complete, press <code>STOP ANNOT</code> .
<code>PLOT GRATICUL</code>	Plots only the graticule. To halt plotting before it is complete, press <code>STOP GRATICUL</code> .
<code>PLOT ORG DSP GRAT</code>	Selects either the display (DSP) or the graticule area (GRAT) for plotting. In either case, the plot fills the entire area defined by the P1 and P2 plot parameters.
<code>PLOTTER ADDRESS</code>	Displays the GPIB address of the plotter. After changing and entering the address, press <code>STORE GPIB ADR</code> .

4-30 Front Panel Key Functions

PLOTTER CONFIG	Accesses a menu for configuring a plotter as a hard-copy device.
PLOT TRACE A	Plots only the contents of trace A and any markers associated with the trace. To halt plotting before it is complete, press STOP TRACE A .
PLOT TRACE B	Plots only the contents of trace B and any markers associated with the trace. To halt plotting before it is complete, press STOP TRACE B .
POSITIVE BIAS	Selects positive mixer bias for an external mixer.
POSTSCLR	Displays the value of the post-scaler divider within the fractional N assembly.
POWER MENU	Accesses the power measurements including occupied power bandwidth, channel power and carrier power.
POWER ON	Sets the instrument state to the state stored in the power-on register.
PRESEL AUTO PK	Automatically peaks the preselector for the selected signal on a trace.
PRESEL MAN ADJ	Permits manual adjustment of the preselector. Peak the preselector using the data keys, the step keys, or the knob.
PRESEL PEAK	Displays a menu of functions for preselected external mixers. <i>Preselected external mixing only.</i>
PRESET	Sets the spectrum analyzer to the preset state.
PRINTER ADDRESS	Displays the GPIB address of the printer. After changing the address, press STORE GPIB ADR .
PRINTER CONFIG	Accesses a menu for configuring a printer as a hard-copy device.
PURGE CORR	Allows you to purge all of the ampcor correction points that are in active memory.

PWR MENU
HELP

Includes measurement information for making occupied power bandwidth, channel power, carrier power, and adjacent channel power measurements.

PWR ON STATE

Saves the current state in the power-on register. The spectrum analyzer is set to this state whenever **LINE** is turned on or when **POWER ON** is pressed.

PWR SWP ON OFF

Switches the power-sweep function on and off. The tracking generator output power sweeps over the chosen amplitude range. *8560E/EC Option 002 only.*

RANGE LVL

Activates the dynamic range level function and ensures there is no signal compression in the displayed range. For use with **NORMLIZE ON OFF**.

RAW OSC FREQ

Displays the value of the raw oscillator frequency which is used to generate the fractional N frequency.

RBW/SPAN RATIO

Displays the current coupling ratio between the resolution bandwidth and the frequency span.

REALIGN LO & IF

Activates the LO and IF alignment routines for a complete LO and IF alignment.

REAR PANEL

Accesses a menu for selecting the signals available at the rear panel connectors J8 (LO SWP|FAV OUTPUT) and J9 (10 MHz REF IN/OUT).

RECALL

Accesses a menu of functions that recall instrument data.

RECALL AMPCOR

Recalls a previously stored table of amplitude correction (ampcor) points.

RECALL ERRORS

Displays the last error that has occurred. Use the step keys to cycle through accumulated errors.

RECALL OPN/SHRT

Recalls the stored, averaged open/short calibration data into trace B, and sets the instrument to the calibration state.

RECALL PRSEL PK

Recalls the preselector data initially stored in the user table using **SAVE PRSEL PK**. *For use with*

4-32 Front Panel Key Functions

preselected external mixing or with internal mixing above 2.9 GHz.

RECALL STATE

Displays a menu of ten registers from which instrument states can be recalled and displayed.

RECALL THRU

Recalls stored thru calibration data into trace B and sets the instrument to the calibration state.

RECALL TO TR A

Displays a menu of eight registers from which data can be recalled and placed in trace A.

RECALL TO TR B

Displays a menu of eight registers from which data can be recalled and placed in trace B.

REF LVL

Activates the reference-level function.

REF LVL ADJ	Permits adjusting the spectrum analyzer internal gain so that when the calibrator signal is connected to the input, the reference level at top screen equals the calibrator amplitude.
REF LVL OFFSET	Introduces an offset to all amplitude readouts, but does not change the position of the on-screen trace.
RES BW AUTO MAN	Adjusts the resolution bandwidth of the spectrum analyzer. Resolution bandwidth may be coupled to other functions (AUTO) or adjusted manually (MAN).
SAMPLER FREQ	Displays the sampling oscillator frequency and loop bandwidth compensation value corresponding to the current start frequency.
SAMPLER HARMONIC	Displays the sampler harmonic number corresponding to the current start frequency.
SAVE	Accesses a menu for storing instrument data.
SAVE AMPCOR	Saves the current table of amplitude correction (ampcor) points.
SAVE PRSEL PK	Saves the current preselector-peak data in a data table. <i>For use with preselected external mixing or with internal mixing above 2.9 GHz.</i>
SAVE STATE	Displays a menu of ten registers for storing the current instrument state.
SAVE TRACE A	Displays a menu of eight registers for storing trace contents.
SAVE TRACE B	Displays a menu of eight registers for storing trace contents.
SAVELOCK ON OFF	When this function is on, the data in the state and trace registers cannot be erased or overwritten. No new data may be entered into the registers until this function is turned off.

4-34 Front Panel Key Functions

SCREEN TITLE	Accesses a menu of functions for creating on-screen titles.
SCROLL CORR PTS	Allows you to scroll through the list of ampcor amplitude correction points.
SELECT CHAR	Causes the currently selected character in the active block to appear in the next available position of the title.
SGL SWP	Initiates one sweep and activates single-sweep mode.
SIG ID AT MKR	Locates the frequency and harmonic number of the mixer response where a marker has been positioned. <i>Only available with firmware revisions ≤ 920528 or with Option 008.</i>
SIG ID—CF	Sets the center frequency to the frequency obtained from executing SIG ID AT MKR. <i>Only available with firmware revisions ≤ 920528 or with Option 008.</i>
SID ID ON OFF	Switches manual signal identification on and off. Signals that are correct for the selected band are identified by being shifted less than 50 kHz. Limit frequency spans to less than 20 MHz for best performance. <i>Only available with firmware revisions ≤ 920528 or with Option 008.</i>
SIG TRK ON OFF	Switches the signal tracking function ON and OFF. When it is ON, it keeps the active marker on the peak of the signal where it was initially placed and maintains the center frequency at the marker value.
SIGNAL IDENT	Accesses a menu of signal identification functions for use with unpreselected external mixers. <i>Only available with firmware revisions ≤ 920528 or with Option 008.</i>
SINGLE MEASURE	Puts the spectrum analyzer in single sweep mode, completing the current measurement.

SOURCE CAL MENU

Accesses a menu of functions used to calibrate frequency-response errors in test setups when using a tracking generator.

SPACE

Places a blank space in the next available character position in the title.

SPACING/BANDWIDTH

Accesses the channel spacing and channel bandwidth softkeys for use in adjacent channel power (ACP) measurements.

SPAN

Activates the frequency span, sets the spectrum analyzer to center-frequency span mode, and accesses a menu of span related functions.

SPAN

Activates the span width function and sets the spectrum analyzer to center-frequency span mode.

SPAN ZOOM

Tracks a marked signal and activates the span function so that the span may be reduced quickly without losing the signal from the display. If no marker is present, the peak-search function is executed before the span is reduced. See also **SIG TRK ON OFF**.

SQUELCH ON OFF

Turns squelch on and off and adjusts the squelch level for demodulation.

SRC PWR OFFSET

Offsets the displayed power of the tracking generator. *8560E/EC Option 002 only.*

SRC PWR ON OFF

Switches the tracking generator output power on and off.

SRC PWR STP SIZE

Sets the step size of the source power level, the source power offset, and the power sweep range. *8560E/EC Option 002 only.*

START FREQ

Activates the start frequency and sets the spectrum analyzer to start stop mode.

STOP FREQ

Activates the stop frequency and sets the spectrum analyzer to start stop mode.

4-36 Front Panel Key Functions

SWEEP	Activates the sweep time function and accesses a menu of sweep related functions.
SWEEP CONT SGL	Allows you to select continuous sweep or single sweep mode.
SWP CPL SR SA	Selects an auto-coupled sweep time equation for stimulus-response (SR) measurements with a tracking generator or for spectrum-analyzer (SA) measurements.
SWP TIME AUTO MAN	Adjusts the sweep time of the spectrum analyzer. The sweep time may be coupled to bandwidth and span settings (AUTO) or adjusted manually (MAN).
THRESHLD ON OFF	Sets a threshold that determines the lower limit of an active trace. Adjust the threshold using the data keys, the step keys, or the knob.
TITLE DONE	Ends editing of the current title.
TRACE	Accesses a menu of trace functions.
TRACE A B	Accesses trace-related functions for traces A and B.
TRACKING GENRATOR	Accesses a menu of tracking generator functions.
TRACKING PEAK	Adjusts the coarse and fine tracking adjustments to peak the tracking generator response on the spectrum analyzer display automatically. <i>8560E/EC Option 002 only.</i>
TRIG	Accesses a menu of trigger functions.
TRIG POL POS NEG	Sets the sweep to trigger on the rising edge (POS) or the falling edge (NEG) of the trigger signal.
UNITS AUTO MAN	Accesses a menu of amplitude units. AUTO indicated default units for the amplitude scale are in use. MAN indicates other units can be selected.
VBW/RBW RATIO	Displays the coupling ratio between the video bandwidth and the resolution bandwidth.

V/GHz .25 .50	Selects a 0.25 V/GHz or 0.5 V/GHz output for connector J8 on the rear panel. This is the frequency-analog voltage (FAV). It is primarily used with external tracking generators or external mixers.
VID AVG ON OFF	Turns video averaging on and off. When on, it smooths the trace by averaging successive traces.
VIDEO	Sets the trigger to video mode. Sweep triggers occur whenever the input signal passes through the video trigger level, with the selected polarity.
VIEW A	Displays the current contents of trace A, but does not update the contents.
VIEW B	Displays the current contents of trace B, but does not update the contents.
VIEW TBL TRCE	Sets the display to show a table of the ACP measurement results or to show a trace.
VOLTS	Selects volts as the display amplitude units.
WATTS	Selects watts as the display amplitude units.
WEIGHT α	Enters the α factor for root-raised-cosine weighting on an ACP measurement.
WEIGHT T	Enters the T factor for root-raised-cosine weighting on an ACP measurement.
WEIGHTING $\sqrt{\text{COS}}$ OFF	Turns on and off root-raised-cosine weighting for an ACP measurement.
ZERO SPAN	Sets the span to 0 Hz. This displays the input signal in an amplitude versus time mode which is especially useful for viewing modulation.

4-38 Front Panel Key Functions

Programming Reference

This chapter includes a table with the programming commands grouped according to similar function, and including a brief definition. When you find the desired command, the chapter also includes a more detailed key word description, syntax information, and an example of how to use each command. The examples are written in HP BASIC.

If you have a series of front-panel key presses that you would like to write a program for, there is a cross reference to help you find the equivalent programming commands.

A list of the 85620A mass memory module commands can be found in the section on “Module Commands.”

Topics documented in this chapter include:

- Programming Commands (functional index)
- Key versus Programming Command
- Mass Memory Module Commands
- Programming Commands (alphabetical index)
- Notation Conventions
- Syntax Conventions
- Secondary Key Word Summary

Programming Commands (functional index)

Programming commands are listed by function in this section. The equivalent key or softkey and a brief description are also listed. Alternate commands common to the 8560 E-Series and the 8566A/8568A are included. The alternate commands are shown in parentheses ().

Programming Commands (functional index)

AMPLITUDE

AMPCOR	AMPCOR ON OFF	Turns on and off the correction for system flatness.
AMPCORDATA	EDIT AMPCOR	Enters amplitude correction data.
AMPCORSIZE		Indicates the number of correction points.
AMPCORRCL	RECALL AMPCOR	Recalls ampcor data.
AMPCORSAVE	SAVE AMPCOR	Saves ampcor data.
AT	ATTEN AUTO MAN	Specifies input attenuation.
AUNITS	AMPTD UNITS	Specifies amplitude units for input, output, and display.
COUPLE	COUPLE AC DC	Selects dc or ac coupling.
LG	LOG dB/DIV	Specifies log scale.
LN	LINEAR	Specifies linear scale.
MKRL	MARKER → REF LVL	Moves active marker amplitude to reference level (E4).
ML	MAX MXR LVL	Specifies the mixer level.
NRPOS	NORM REF POSN	Adjusts the normalized reference position.
PP	PRESEL AUTO PK	Peaks preselector.
PSDAC	PRESEL MAN ADJ	Adjusts or returns preselector-peak DAC number.
RL	REF LVL or RANGE LVL	Specifies the amplitude value of the reference level or range level.
RLCAL	REF LVL ADJ	Calibrates reference level.
ROFFSET	REF LVL OFFSET	Offsets all amplitude readouts without affecting the trace.

Programming Commands (functional index)

AUTO COUPLING

AT AUTO	ATTEN AUTO MAN (AUTO)	Auto-couples the RF attenuator (CA).
AUTOCP	ALL	Auto-couples all controls.
RB AUTO	RES BW AUTO MAN (AUTO)	Auto-couples resolution bandwidth (CR).
RBR	RBW/SPAN RATIO	Specifies coupling ratio of resolution bandwidth and frequency span.
SS AUTO	CF STEP AUTO MAN (AUTO)	Auto-couples center-frequency step-size (CS).
ST AUTO	SWP TIME AUTO MAN (AUTO)	Auto-couples sweep time (CT).
VB AUTO	VIDEO BW AUTO MAN (AUTO)	Auto-couples video bandwidth (CV).
VBR	VBW/RBW RATIO	Specifies coupling ratio of video bandwidth and resolution bandwidth.

AUXILIARY CONTROL

CNVLOSS	AVERAGE CNV LOSS	Sets reference-level offset to compensate for external mixer conversion loss.
DEMOM	AM DEMOD ON OFF or FM DEMOD ON OFF	Turns demodulation on or off.
DEMOMAGC	AGC ON OFF	Controls demodulation auto gain.
DEMOMDT	DEMOM TIME	Demodulation time.
EXTMXR	EXT MXR PRE UNPRE	Specifies the external mixing mode as either preselected or unpreselected.

5-4 Programming Reference

Programming Commands (functional index)

FREF	10 MHz EXT INT	Specifies the frequency reference source.
FULBAND	FULL BAND	Sets start and stop frequencies for full waveguide bands.
HNLOCK	LOCK HARMONIC	Locks to specified harmonic number.
HNUNLK	LOCK ON OFF	Unlocks the specified harmonic number.
IDCF	SIG ID → CF	Sets center frequency to frequency of SIGID.
IDFREQ		Returns frequency of identified signal.
MBIAS	BIAS	Specifies the bias level for external mixers.
MKN	MARKER NORMAL	Activates marker and moves marker to specified frequency or center screen (M2).
MKPX	PEAK EXCURSN	Specifies minimum excursion for peak identification.
MXRMODE	EXTERNAL MIXER or INTERNAL MIXER	Specifies either internal or external mixing.
NORMLIZE	NORMLIZE ON OFF	Activates normalization routine.
NRL	NORM REF LVL	Sets the normalized reference level.
NRPOS	NORM REF POSN	Adjusts the normalized reference position.
PP	PRESEL AUTO PK	Peaks preselector.
PSDAC	PRESEL MAN ADJ	Adjusts or returns preselector-peak DAC number.
RCLOSCAL	RECALL OPN/SHRT	Recalls stored open/short trace calibration data.
RCLTHRU	RECALL THRU	Recalls stored thru calibration data.

Programming Commands (functional index)

RL	REF LVL , RANGE LVL	Adjusts the reference level or range level.
SIGID	SIG ID AT MKR , SIG ID ON OFF	Identifies signals for external mixing frequency bands.
SQUELCH	SQUELCH ON OFF	Controls squelch for demodulation.
SRCALC	ALC INT EXT	Selects internal or external leveling.
SRCRSTK	MAN TRK ADJ	Coarse-tunes the tracking generator oscillator.
SRCFINTK	MAN TRK ADJ	Fine-tunes the tracking generator oscillator.
SRCPOFS	SRC PWR OFFSET	Offsets the displayed tracking-generator source power.
SRCPSTP	SRC PWR STP SIZE	Sets the step size of the source power level.
SRCPSWP	PWR SWP ON OFF	Controls the power-sweep function.
SRCPWR	SRC PWR ON OFF	Controls the output power of the tracking generator.
SRCTKPK	TRACKING PEAK	Peaks the tracking generator response.
STOREOPEN	CAL OPN/SHRT	Saves open-input calibration data for use with STORESHORT.
STORESHORT	CAL OPN/SHRT	Averages shorted-input and open-input calibration data and saves the average.
STORETHRU	CAL THRU	Stores thru-calibration data.
SWPCPL	SWP CPL SR SA	Selects a stimulus response or spectrum analyzer coupled sweep time.
SWPOUT	REAR PANEL	Specifies the sweep output.

5-6 Programming Reference

Programming Commands (functional index)

BANDWIDTH

RB	RES BW AUTO MAN	Specifies resolution bandwidth.
RBR	RBW/SPAN RATIO	Specifies the coupling ratio of resolution bandwidth and frequency span.
VAVG	VID AVG ON OFF	Turns video averaging on or off.
VB	VIDEO BW AUTO MAN	Specifies video bandwidth.
VBR	VID/RBW RATIO	Specifies coupling ratio of video bandwidth and resolution bandwidth.

Programming Commands (functional index)

CALIBRATION

ADJALL	REALIGN LO & IF	Initiates power-on adjustment sequence.
ADJCRT	CRT ADJ PATTERN	Initiates CRT adjustment patterns.
ADJIF	IF ADJ ON OFF, ADJ CURR IF STATE, FULL IF ADJ	Initiates IF adjustment sequence.
AMPCOR	AMPCOR ON OFF	Turns on and off the correction for system flatness.
AMPCORDATA	EDIT AMPCOR	Enters amplitude correction data.
AMPCORSIZE		Indicates the number of correction points.
AMPCORRCL	RECALL AMPCOR	Recalls ampcor data.
AMPCORSAVE	SAVE AMPCOR	Saves ampcor data.
FDIAG	FREQ DIAGNOSE, LO FREQ, SAMPLER FREQ, SAMPLER HARMONIC, FRAC N FREQ, POSTSCLR, RAW OSC FREQ	Returns the specified frequency diagnostic information.
RLCAL	REF LVL ADJ	Calibrates reference level.

Programming Commands (functional index)

CONFIGURATION

EXTMXR	EXT MXR PRE UNPRE	Selects either preselected or unpreselected external mixing mode.
ID	DATECODE &OPTIONS	Returns the model number of analyzer used.
OP		Returns the display lower-left and upper-right coordinates.
PLOT	(COPY)	Sends analyzer display to a plotter.
PLOTORG	PLOT ORG DSP GRT	Scaling points for plot.
PLOTSRC	PLOT ANNOT , PLOT GRATICUL , PLOT ORG DSP GRAT , PLOT TRACE A , PLOT TRACE B	Specifies plot source.
PRINT	(COPY)	Sends analyzer display to a printer.
REV	DATECODE &OPTIONS	Returns analyzer firmware revision date.
SER	DATECODE &OPTIONS	Returns analyzer serial number.

COPY

PLOT	(COPY) with COPY DEV PRNT PLT	Sends analyzer display to a plotter.
PRINT	(COPY) with COPY DEV PRNT PLT	Sends analyzer display to a printer.

Programming Commands (functional index)

DISPLAY

ANNOT	ANNOT ON OFF	Turns annotation on or off.
BLANK	BLANK A or BLANK B	Stores and blanks specified trace register (A4 and B4).
DL	DSPL LIN ON OFF	Specifies display-line level in dBm, and turns the display line on or off. (L0)
FDSP	FREQ DSP OFF	Turns all frequency display annotation off.
GRAT	GRAT ON OFF	Turns graticule on or off.
TH	THRESHLD ON OFF	Specifies display threshold value.
TITLE	SCREEN TITLE	Writes specified ASCII characters in title block area of display.

FREQUENCY

CF	CENTER FREQ	Specifies center frequency.
FA	START FREQ	Specifies start frequency.
FB	STOP FREQ	Specifies stop frequency.
FOFFSET	FREQ OFFSET	Specifies frequency offset.
SS	CF STEP AUTO MAN	Specifies center frequency step size.

Programming Commands (functional index)

FREQUENCY COUNT

MKFC	COUNTER ON OFF	Turns the frequency counter on or off.
MKFCR	COUNTER RES	Specifies resolution of the frequency counter.
MKD	MARKER DELTA	Moves delta marker to specified frequency (M3).
MKN	MARKER NORMAL	Moves marker to specified frequency or center screen (M2).
MKPX	PEAK EXCURSN	Specifies minimum excursion for peak identification.

HOLD

HD	HOLD	Holds or disables data entry and blanks active function CRT readout.
----	------	--

Programming Commands (functional index)

INFORMATION AND SERVICE DIAGNOSTICS

ADJALL	REALIGN LO & IF	Initiates power-on adjustment sequence.
ADJCRT	CRT ADJ PATTERN	Initiates CRT adjustment patterns.
ADJIF	FULL IF ADJ	Initiates IF adjustment sequence.
DONE		Returns a 1 when task has been completed.
ERR	RECALL ERRORS	Returns list of instrument error codes.
ET	ELAPSED TIME	Returns elapsed time.
FDIAG	FREQ DIAGNOSE	Returns the specified frequency diagnostic information.
ID	DATECODE &OPTIONS	Returns the model number of analyzer used.
PSDAC	PRESEL MAN ADJ	Adjusts or returns preselector-peak DAC number.
REV	DATECODE &OPTIONS	Returns analyzer firmware revision date.
RLCAL	REF LVL ADJ	Calibrates reference level.
SER	DATECODE &OPTIONS	Returns analyzer serial number.

MARKER

MKA		Amplitude of active marker (MA).
MKBW	3 dB POINTS , 6 dB POINTS	Finds the signal bandwidth at the specified power level.
MKCF	MARKER → CF	Enters marker frequency into center frequency (E2).

5-12 Programming Reference

Programming Commands (functional index)

MKD	MARKER DELTA	Moves delta marker to specified frequency (M3).
MKDR	MARKER 1/DELTA	Marker delta reciprocal, readout in time.
MKF		Frequency of active marker (MF).
MKMIN		Moves marker to minimum signal detected.
MKN	MARKER NORMAL	Moves marker to specified frequency or center screen (M2).
MKNOISE	MKRNOISE ON OFF	Averages noise value at marker and normalizes to 1 Hz bandwidth.
MKOFF		Turns the active marker off (M1).
MKPK	NEXT PEAK , NEXT PK RIGHT , NEXT PK LEFT	Moves marker to signal peak (E1).
MKPT	PEAK THRESHLD	Specifies marker peak threshold.
MKPX	PEAK EXCURSN	Specifies minimum excursion for peak identification.
MKRL	MARKER → REF LVL	Moves active marker to reference level (E4).
MKSP	MKR Δ → SPAN	Moves marker delta frequency into span.
MKSS	MARKER → CF STEP	Moves marker frequency to center-frequency step-size (E3).
MKT	MARKER NORMAL (Span set to 0)	Positions marker at point corresponding to the time from beginning of sweep.
MKTRACK	SIG TRK ON OFF	Turns marker signal track on (MT1) or off (MT0).

Programming Commands (functional index)

MEASURE/USER

ACPACCL	ACCEL RAT	Changes the speed of the adjacent channel power measurement.
ACPALPHA	WEIGHT α	Sets the adjacent channel power alpha weighting.
ACPALTCH	# ALT CHANNELS	Sets the number of alternate channel pairs for the adjacent channel power measurement.
ACPBRPER	BURST PERIOD	Sets the burst period for an adjacent channel power measurement.
ACPBRWID	BURST WIDTH	Sets the burst width for an adjacent channel power measurement.
ACPBW	CHANNEL BANDWIDTH	Sets the channel bandwidth for an adjacent channel power measurement.
ACPCOMPUTE	ACP COMPUTE	Performs an adjacent channel power computation with current instrument settings.
ACPFRQWT	WEIGHTING $\sqrt{\text{COS}}$ OFF	Sets the adjacent channel power frequency weighting.
ACPGRAPH	ACPGRAPH ON OFF	Turns on or off the adjacent channel power graph mode.
ACPLOWER		Returns the lower adjacent channel power result.
ACPMAX		Returns the maximum adjacent channel power result.
ACPMEAS	AUTO ACP MEASURE	Performs an automatic adjacent channel power measurement.

Programming Commands (functional index)

ACPMSTATE	ACPSTATE DFL CURR	Selects default or current for the measurement state of an adjacent channel power measurement.
ACPMETHOD	METHODS	Changes the adjacent channel power measurement algorithm.
ACPPWR TX		Returns the total power transmitted in an adjacent channel power measurement.
ACPRSLTS		Returns an array of the results of the adjacent channel power measurement.
ACPSP	CHANNEL SPACING	Sets the channel spacing for an adjacent channel power measurement.
ACPT	WEIGHT T	Sets the adjacent channel power T weighting.
ACPUPPER		Returns the upper adjacent channel power result.
CARROFF	AVG "OFF" POWER	Measures the average carrier power when the burst is off.
CARRON	AVG "ON" POWER	Measures the average carrier power when the burst is on.
CHANPWR	CHAN PWR OVER BW	Measures the power in the channel power bandwidth.
CHANNEL	CHAN UP >>>> CHAN DOWN <<<<	Changes the center frequency by one channel width.
CHPWRBW	CHPWR BW []	Sets the bandwidth for the desired channel power.
DELMKBW	Δ MARKER OCC BW	Measures the occupied power bandwidth with respect to the power between the delta markers.

Programming Commands (functional index)

FFT	FFT MEAS	Performs a discrete Fourier transform.
MEAS		Queries the status of the sweep or measurement for running continuously, or a single time.
MKCHEDGE	CH EDGES — ΔMKR	Moves the delta markers to a channel spacing around the center frequency.
MKDELCHBW	MKRA — CHPWR BW	Sets the channel power bandwidth to the value between the delta markers.
MKMCF	MKR MEAN — CF	Changes the center frequency to the midpoint of the two displayed markers.
OCCUP	OCCUPIED [%]	Enters the desired percent of the occupied channel power.
PWRBW	OCCUPIED POWER BW	Returns the bandwidth equal to a percentage of total power.
TWNDOW		Creates a trace array for the FFT function.

MODULE

This key provides access to the commands that are available when using the 85620A mass memory module with the spectrum analyzer. See Table 5-2 for a list of the commands. (There are no remote commands for the 85629B test and adjustment module.)

Programming Commands (functional index)

OUTPUT FORMAT

AUNITS	AMPTD UNITS	Specifies amplitude units for input, output, and display.
MKA		Returns marker amplitude (MA).
MKF		Returns marker frequency (MF).
SWPOUT	REAR PANEL	Specifies the sweep output.
TRA		Outputs trace A (TA).
TRB		Outputs trace B (TB).
TDF		Selects trace data output format as real number parameter units (P) format, binary (B) format, A-block format, I-block format, and measurement units (M) format.

PRESET

IP	PRESET	Sets instrument parameters to preset values.
----	--------	--

Programming Commands (functional index)

RECALL AND SAVE

ERR	RECALL ERRORS	Returns list of instrument error codes.
ET	ELAPSED TIME	Returns elapsed time.
PSDAC	PRESEL MAN ADJ	Adjusts or returns preselector-peak DAC number.
PSTATE	SAVELOCK ON OFF	Protect saved states (save lock).
RCLS	RECALL STATE	Recalls previously saved state (RC).
RCLT	RECALL TO TRA , RECALL TO TRB	Recall specified trace data.
SAVES	PWR ON STATE , SAVE STATE	Saves current state of the analyzer in the specified register (SV).
SAVET	SAVE TO TRA , SAVE TO TRB	Save specified trace data.

SERVICE REQUEST

RQS		Specifies the decimal weighing of status byte bits that are allowed during service request. Set to 0 with power-up or device clear. See Chapter 7 of the <i>8560 E-Series and EC-Series Spectrum Analyzer User's Guide</i> .
SRQ		Sets service request if operand bits are allowed by RQS.
STB		Returns the decimal equivalent of the bits set in the status byte.

Programming Commands (functional index)

SPAN

FS	FULL SPAN	Specifies the full frequency span for the spectrum analyzer.
SP	SPAN , ZERO SPAN	Specifies the frequency span.

SWEEP

CONTS	SWEEP CONT SGL (CONT)	Selects continuous sweep mode (S1).
DLYSWP	DLY SWP [], DLY SWP ON OFF	Delays the start of the sweep until the specified time elapses after the trigger event.
GATE	GATE ON OFF	Turns on or off the video-gating function.
GATECTL	GATE CTL EDGE LVL	Selects between the edge and the level mode for video-gate function.
GD	GATE DLY []	Sets the delay time from when the gate trigger occurs to when the gate is turned on.
GL	GATE LEN []	Sets the length of time the video gate is turned on.
GP	EDGE POL POS NEG or LVL POL POS NEG	Sets the polarity (positive or negative) for the gate trigger.
MEAS		Queries the status of the sweep or measurement for running continuously, or a single time.
SNGLS	SWEEP CONT SGL (SGL)	Selects single sweep mode (S2).
ST	SWP TIME AUTO MAN	Specifies sweep time.
TS		Takes a sweep.

Programming Commands (functional index)

SYNCHRONIZATION

DONE		Returns a 1 when task has been completed.
TS		Takes a sweep.

TRACE

DET	DETECTOR MODES	Specifies video detector type.
-----	----------------	--------------------------------

TRACE MATH

AMB	$A - B \rightarrow A$ ON OFF	$A - B$ into A (C1 and C2).
AMBPL	$A - B + DL \rightarrow A$ ON OFF	$A - B + DL$ into A.
APB	$A + B \rightarrow A$	$A + B$ into A.
AXB	A EXCH B	Exchanges A and B (EX).
BML	$B - DL \rightarrow B$	$B - DL$ into B (BL).

TRACE PROCESSING

BLANK	BLANK A or BLANK B	Stores and blanks specified trace register (A4 and B4).
CLRW	CLEAR WRITE A or CLEAR WRITE B	Clear-writes specified trace register (A1 and B1).

MINH		Holds the minimum trace register values.
MXMH	MAX HOLD A or MAX HOLD B	Max-holds the specified trace register (A2 and B2).
NORMLIZE	NORMLIZE ON OFF	Activates normalization routine.
NRL	NORM REF LVL	Sets the normalized reference level.
RCLT	RECALL TO TRA , RECALL TO TRB	Recalls specified trace data.
SAVET	SAVE TO TRA , SAVE TO TRB	Saves specified trace data.
TRA		Input and output of trace A.
TRB		Input and output of trace B.
VAVG	VID AVG ON OFF	Turns video averaging on or off.
VIEW	VIEW A or VIEW B	Views specified trace register (A3 and B3).

TRIGGER

CONTS	SWEEP CONT SGL (CONT)	Selects continuous sweep mode (S1).
SNGLS	SWEEP CONT SGL (SGL)	Selects single sweep mode (S2).
TM	FREE RUN , VIDEO , LINE , EXTERNAL	Selects trigger mode: free run (T1), video (T4), line (T2), external (T3).
TRIGPOL	TRIG POL POS NEG	Selects the edge (positive or negative) of the trigger input that causes the trigger event.
VTL	VIDEO	Video trigger level.

Key versus Programming Command

This table lists the front panel keys in alphabetical order. Next to a key is the related programming command, if there is one.

Table 5-1. Front Panel Key Versus Command

Key	Programming Command
# ALT CHANNELS	ACPALTCH
ΔMARKER OCC BW	DELMKBW
0—10V LO SWP	SWPOUT
.5 V/GHz (FAV)	SWPOUT
2BW METHOD	ACPMETHOD
3dB POINTS	MKBW
6dB POINTS	MKBW
10 MHz EXT INT	FREF
A	
A+B→A	APB
A—B→A ON OFF	AMB
A—B+DL→A ON OFF	AMBPL
ACCELERAT	ACPACCL
ACCELERAT FASTER	ACPACCL
ACCELERAT FASTEST	ACPACCL
ACCELERAT NORMAL	ACPACCL
ACP AUTO MEASURE	ACPMEAS

Key versus Programming Command

Table 5-1. Front Panel Key Versus Command (continued)

Key	Programming Command
A (continued)	
ACP COMPUTE	ACPCOMPUTE
ACPGRAPH ON OFF	ACPGRAPH
ACP MENU	—
ACP SETUP	—
ACPSTATE DFL CURR	ACPMSTATE
A EXCH B	AXB
ADJ CURR IF STATE	ADJIF
AGC ON OFF	DEMODAGC
ALC INT EXT	SRCALC
ALL	AUTOCPPL
AM DEMOD ON OFF	DEMOD
AM/FM DEMOD	—
AMPCOR MENU	—
AMPCOR ON OFF	AMPCOR
AMPLITUDE	RL
AMPTD CORRECT	—
AMPTD UNITS	AUNITS
ANALOG METHOD	ACPMETHOD
ANALYZER ADDRESS	—
ANNOT HELP	—
ANNOT ON OFF	ANNOT

Key versus Programming Command

Table 5-1. Front Panel Key Versus Command (continued)

Key	Programming Command
A (continued)	
ATTEN AUTO MAN	AT
AUTO ACP MEASURE	ACPMEAS
(AUTO COUPLE)	—
(AUX CTRL)	—
AVERAGE CNV LOSS	CNVLOSS
AVG "OFF" POWER	CARROFF
AVG "ON" POWER	CARRON
B	
B-DL→B	BML
B & W	PRINT
BACK SPACE	—
BIAS	MBIAS
BIAS OFF	MBIAS
BLANK A	BLANK
BLANK B	BLANK
BURST/WEIGHTNG	—
BURST PERIOD	ACPBRPER
BURST WIDTH	ACPBRWID
BURSTPWR METHOD	ACPMETHOD
(BW)	RB

Key versus Programming Command

Table 5-1. Front Panel Key Versus Command (continued)

Key	Programming Command
C	
CAL	—
CAL OPN/SHRT	STOREOPEN, STORESHORT
CAL THRU	STORETHRU
CARRIER PWR MENU	—
CENTER FREQ	CF
CF/2→CF	—
CF*2→CF	—
CF STEP AUTO MAN	SS
CH EDGES — ΔMKR	MKCHEDGE
CHAN DN <<<<	CHANNEL
CHAN PWR OVER BW	CHPWRBW
CHAN UP >>>>	CHANNEL
CHANNEL BANDWIDTH	ACPBW
CHANNEL PWR MENU	—
CHANNEL SPACING	ACPSP
CHPWR BW []	CHPWRBW
CHAR SET 1 2	—
CLEAR WRITE A	CLRW
CLEAR WRITE B	CLRW
CNV LOSS VS FREQ	—

Key versus Programming Command

Table 5-1. Front Panel Key Versus Command (continued)

Key	Programming Command
C (continued)	
COLOR	PRINT
CONFIG	—
CONT MEASURE	MEAS
COPY	PLOT, PRINT
COPY DEV PRNT PLT	—
COUNTER ON OFF	MKFC
COUNTER RES	MKFCR
COUPLING AC DC	COUPLE
CRT ADJ PATTERN	ADJCRT
D	
DATECODE &OPTIONS	ID, REV, SER
dB μ V	AUNITS
dBm	AUNITS
dBmV	AUNITS
DELETE CORR PT	AMPCORDATA
DEMOD TIME	DEMODT
DETECTOR MODES	—
DETECTOR NEG PEAK	DET
DETECTOR NORMAL	DET
DETECTOR POS PEAK	DET
DETECTOR SAMPLE	DET

Key versus Programming Command

Table 5-1. Front Panel Key Versus Command (continued)

Key	Programming Command
D (continued)	
DISPLAY	—
DLY SWEEP []	DLYSWP
DLY SWP ON OFF	DLYSWP
DONE EDIT	—
DSPL LIN ON OFF	DL
E	
EDGE POL POS NEG	GP
EDIT AMPCOR	AMPCORDATA
EDIT AMPL	AMPCORDATA
EDIT FREQ	AMPCORDATA
ELAPSED TIME	ET
ERASE TITLE	—
EXIT ACP	—
EXIT AMPCOR	—
EXTERNAL	TM
EXTERNAL MIXER	MXRMODE
EXT MXR PRE UNPR	EXTMXR
F	
FACTORY PRSEL PK	—
FFT MEAS	FFT
FM DEMOD ON OFF	DEMOMD
FOCUS	—

Key versus Programming Command

Table 5-1. Front Panel Key Versus Command (continued)

Key	Programming Command
F (continued)	
FRAC N FREQ	FDIAG
FREE RUN	TM
(FREQ COUNT)	MKFC
FREQ DIAGNOSE	FDIAG
FREQ DSP OFF	FDSP
FREQ OFFSET	FOFFSET
(FREQUENCY)	CF
FULL BAND	FULBAND
FULL IF ADJ	ADJIF
FULL SPAN	FS
G	
GATE CTL EDGE LVL	GATECTL
GATE DLY []	GD
GATE LEN []	GL
GATE ON OFF	GATE
GATED METHOD	ACPMETHOD
GATED VIDEO	—
GRAT ON OFF	GRAT
H	
(HOLD)	HD

Key versus Programming Command

Table 5-1. Front Panel Key Versus Command (continued)

Key	Programming Command
I IF ADJ ON OFF INTENSTY INTERNAL MIXER	ADJIF — MXRMODE
L LAST SPAN LAST STATE LINE LINEAR LOCK HARMONIC LOCK ON OFF LO FREQ LOG dB/DIV LVL POL POS NEG	SP RCLS TM LN HNLOCK HNLOCK, HNUNLK FDIAG LG GP
M MAN TRK ADJ MARKER —CF MARKER —CF STEP MARKER —REF LVL	SRCCRSTK, SRCFINTK MKCF MKSS MKRL

Key versus Programming Command

Table 5-1. Front Panel Key Versus Command (continued)

Key	Programming Command
M (continued)	
MARKER 1/DELTA	MKDR
MARKER DELTA	MKD
MARKER NORMAL	MKN
MARKERS OFF	MKOFF
MAX HOLD A	MXMH
MAX HOLD B	MXMH
MAX MXR LEVEL	ML
MEAS/USER	—
METHODS	ACPMETHOD
MKR	MKN
MKR→	MKN
MKR Δ→CF	MKCF
MKR Δ→CF STEP	MKSS
MKR Δ →CHPWR BW	MKDELCHBW
MKR Δ →SPAN	MKSP
MKR 1/Δ→CF	—
MKR 1/Δ->CF STEP	—
MKR MEAN → CF	MKMCF
MKRNOISE ON OFF	MKNOISE
MODULE	—

Key versus Programming Command

Table 5-1. Front Panel Key Versus Command (continued)

Key	Programming Command
N NEGATIVE BIAS NEW CORR PT NEXT PEAK NEXT PK LEFT NEXT PK RIGHT NORMLIZE ON OFF NORM REF LVL NORM REF POSN	MBIAS AMPCORDATA MKPK MKPK MKPK NORMLIZE NRL NRPOS
O OCCUPIED [%] OCCUPIED BANDWIDTH OCCUPIED PWR MENU	OCCUP PWRBW —
P PEAK EXCURSN PEAK METHOD PEAK SEARCH PEAK SEARCH PEAK THRSILD PLOT ANNOT PLOT GRATICUL PLOT ORG DSP GRAT PLOT TRACE A PLOT TRACE B	MKPX ACPMETHOD MKPK MKPK MKPT PLOTSRC PLOTSRC PLOTORG PLOTSRC PLOTSRC

Key versus Programming Command

Table 5-1. Front Panel Key Versus Command (continued)

Key	Programming Command
P (continued)	
PLOTTER ADDRESS	—
PLOTTER CONFIG	PLOTSRC
POSITIVE BIAS	MBIAS
POSTSCLR	FDIAG
POWER MENU	—
POWER ON	RCLS
PRESEL AUTO PK	PP
PRESEL MAN ADJ	PSDAC
PRESEL PEAK	—
PRESET	IP
PRINTER ADDRESS	—
PRINTER CONFIG	—
PURGE CORR	AMPCORDATA
PWR MENU HELP	—
PWR ON STATE	SAVES
PWR SWP ON OFF	SRCPSWP
R	
RANGE LVL	RL
RAW OSC FREQ	FDIAG
RBW/SPAN RATIO	RBR
REALIGN LO & IF	ADJALL
REAR PANEL	—

Key versus Programming Command

Table 5-1. Front Panel Key Versus Command (continued)

Key	Programming Command
R (continued)	
RECALL	—
RECALL AMPCOR	AMPCORRCL
RECALL ERRORS	ERR
RECALL OPN/SHRT	RCLOSCAL
RECALL PRSEL PK	—
RECALL STATE	RCLS
RECALL THRU	RCLTHRU
RECALL TO TR A	RCLT
RECALL TO TR B	RCLT
REF LVL	RL
REF LVL ADJ	RLCAL
REF LVL OFFSET	ROFFSET
RES BW AUTO MAN	RB
S	
SAMPLER FREQ	FDIAG
SAMPLER HARMONIC	FDIAG
SAVE	—
SAVE AMPCOR	AMPCORSAVE
SAVE PRSEL PK	—
SAVE STATE	SAVES
SAVE TRACE A	SAVET
SAVE TRACE B	SAVET

Key versus Programming Command

Table 5-1. Front Panel Key Versus Command (continued)

Key	Programming Command
S (continued)	
SAVELOCK ON OFF	PSTATE
SCREEN TITLE	TITLE
SCROLL CORR PTS	AMPCORSIZE
SELECT CHAR	—
(SGL SWP)	SNGLS
SIG ID AT MKR	SIGID
SID ID ON OFF	SIGID
SIG ID→CF	IDCF
SIGNAL IDENT	—
SIG TRK ON OFF	MKTRACK
SINGLE MEASURE	MEAS
SOURCE CAL MENU	—
SPACE	—
SPACING/BANDWDTH	—
(SPAN)	SP
SPAN	SP
SPAN ZOOM	—
SQUELCH ON OFF	SQUELCH
SRC PWR OFFSET	SRCPOFS
SRC PWR ON OFF	SRCPWR
SRC PWR STP SIZE	SRCPSTP

Key versus Programming Command

Table 5-1. Front Panel Key Versus Command (continued)

Key	Programming Command
S (continued)	
START FREQ	FA
STOP FREQ	FB
SWEEP	ST
SWEEP CONT SGL	CONTS, SNGLS
SWP CPL SR SA	SWPCPL
SWP TIME AUTO MAN	ST
T	
THRESHLD ON OFF	TH
TITLE DONE	TITLE
TRACE	—
TRACE A B	TRA, TRB
TRACKING GENRATOR	—
TRACKING PEAK	SRCTKPK
TRIG	—
TRIG POL POS NEG	TRIGPOL
U	
UNITS AUTO MAN	AUNITS

Key versus Programming Command

Table 5-1. Front Panel Key Versus Command (continued)

Key	Programming Command
V	
VBW/RBW RATIO	VBR
V/GHz .25 .50	SWPOUT
VID AVG ON OFF	VAVG
VIDEO	TM, VTL
VIDEO BW AUTO MAN	VB
VIEW A	VIEW
VIEW B	VIEW
VIEW TBL TRAC	ACPRSLTS
VOLTS	AUNITS
W	
WATTS	AUNITS
WEIGHT α	ACPALPHA
WEIGHT T	ACPT
WEIGHTNG $\sqrt{\text{COS}}$ OFF	ACPFQWT
Z	
ZERO SPAN	SP

Mass Memory Module Commands

The following commands are available with the 85620A mass memory module. See the documentation for the 85620A for more information.

Table 5-2. Mass Memory Module Commands

ABORT	Controls flow of your program.
ABS	Places the absolute value of the source values in the destination.
ACTVFUNC	Creates a user-defined active function.
ADD	Adds the sources and sends the sum to the destination.
ARRAYDEF	Defines an array.
AUTOEXEC	Turns on or off the function that was defined with the AUTOFUNC command.
AUTOFUNC	Defines a function for automatic execution.
AUTOSAVE	Automatically saves traces.
AVG	Averages the source and the destination.
CARDLOAD	Copies data from the memory card to module memory.
CARDSTORE	Copies data to a memory card.
CATALOG	Catalogs the files in the mass memory module or memory card.
CLRDISP	Clears the display.
CLRSCHED	Clears the Autosave and Autoexec Schedule buffer.
CNTLA	Controls auxiliary control line A.
CNTLB	Controls auxiliary control line B.
CNTLC	Controls auxiliary control line C.
CNTLD	Controls auxiliary control line D.
CNTLI	Reads auxiliary control line I.
CTRLHPIB	Allows the spectrum analyzer to control the GPIB.
DATEMODE	Allows you to set the format for displaying the real-time clock.
DISPOSE	Deletes user-defined functions.
DIV	Divides source 1 by source 2 and places the result in the destination.

Mass Memory Module Commands

Table 5-2. Mass Memory Module Commands (continued)

DSPLY	Displays the value of a variable on the spectrum analyzer screen.
EDITDONE	Indicates that the limit-line editing is complete.
EDITLIML	Allows you to edit the current limit line.
EM	Erases your display memory.
ENTER	Allows the spectrum analyzer to receive data from other devices on the GPIB.
EXP	Places the exponential of the source in the destination.
FUNCDEF	Defines a routine consisting of spectrum analyzer commands, assigns the routine a label, and stores the routine and its label in the user memory.
IF	IF THEN ELSE ENDIF forms a decision and branching construct.
INT	Places the greatest integer that is less than or equal to the source value into the destination.
KEYCLR	Clears softkeys 1 through 6.
KEYDEF	Assigns a label and user-defined function to a softkey.
LCLVAR	Defines a local variable for use within a downloadable program.
LIMD	Enters the delta amplitude value for a limit-line segment.
LIMF	Enters the frequency value for a limit-line segment.
LIMIFAIL	Returns a "0" if the last measurement sweep of trace A is equal to or within the limit-line bounds.
LIMIPURGE	Disposes of the current limit line, but not the limit-line table.
LIMIRCL	Recalls a limit line table from module memory.
LIMIREL	Specifies a relative limit line.
LIMISAV	Saves the current limit-line table in module memory.
LIMITEST	Compares trace A with the current limit-line data.
LIML	Assigns an amplitude value to a limit-line segment in the lower limit line.
LIMM	Assigns a middle amplitude value to a limit-line segment.
LIMTFL	Specifies a flat limit-line segment.

Mass Memory Module Commands

Table 5-2. Mass Memory Module Commands (continued)

LIMITSL	Specifies a sloped limit-line segment.
LIMU	Assigns an amplitude value to a limit-line segment in the upper limit line.
LOG	Takes the logarithm (base 10) of the source, multiplies the result by the scaling factor, then stores it in the destination.
MEAN	Returns the mean value of the given trace in measurement units.
MEM	Returns the amount of spectrum analyzer memory available.
MENU	Selects and displays the softkey menus on the spectrum analyzer screen.
MIN	Compares source 1 and 2, point by point, and stores the lesser of the two in the destination.
MOD	Stores the remainder from the division of source 1 by source 2 in the destination.
MODRCLT	Recalls the trace from module memory.
MODSAVT	Saves the trace in module memory.
MOV	Copies the source values into the destination.
MPY	Multiplies the sources, point by point, and places the results in the destination.
MSDEV	Specifies the mass storage device.
MXM	Compares source 1 and source 2, point by point, sending the greater value of each comparison to the destination.
ONEOS	Executes the list of analyzer commands after the end of the sweep.
OR	Sets the origin.
OUTPUT	Allows the spectrum analyzer to send data to other devices on the GPIB.
PA	Moves the pen to a vector location on the spectrum analyzer screen relative to the reference coordinates (0,0).
PD	Instructs the spectrum analyzer to plot vectors on the spectrum analyzer screen until a PU command is received.
PDA	Sums the probability distribution of amplitude in the destination trace with the amplitude distribution function of the source trace.

Mass Memory Module Commands

Table 5-2. Mass Memory Module Commands (continued)

PDF	Increments an element of the destination trace whenever the corresponding element of the source trace exceeds a threshold.
PEAKS	Sorts signal peaks by frequency or amplitude, stores the results in the destination trace, and returns the number of peaks found.
PR	Moves the pen to a new plot location on the spectrum analyzer screen relative to the current coordinates in display units.
PU	Instructs the spectrum analyzer not to plot vectors on the spectrum analyzer screen until a PD command is received.
RELHPIB	Releases spectrum analyzer control of the GPIB.
REPEAT UNTIL	REPEAT and UNTIL form a looping construct.
RETURN	Stops the operation of a user-defined command and returns program operation to the point where the user-defined function was called.
RMS	Returns the root mean square value of the trace in measurement units.
SADD	Adds a limit-line segment.
SDEL	Deletes the limit-line segment.
SDON	Indicates that the limit-line segment is done.
SEDI	Edits the limit-line segment.
SENDER	Enters the limit-line segment into the limit-line table.
SETDATE	Sets the date of the real-time clock.
SETTIME	Sets the time of the real-time clock.
SHOWMENU	Shows menu.
SKYCLR	Clears user softkey.
SKYDEF	Defines user softkey.
SMOOTH	Smooths the trace according to the number of points specified for the running average.
SQR	Places the square root of the source into the destination.
STDEV	Returns the standard deviation of the trace amplitude in measurement units.

Mass Memory Module Commands

Table 5-2. Mass Memory Module Commands (continued)

SUB	Subtracts source 2 from source 1, point by point, and sends the difference to the destination.
SUM	Returns the sum of the amplitudes of the trace elements in measurement units.
SUMSQR	Returns the sum of the squares of the amplitude of each trace element.
TEXT	Writes text on the analyzer screen at the current pen position.
TIMEDATE	Sets the time and date of the real-time clock.
TRDEF	Declares a user-defined trace.
VARDEF	Creates a user-defined variable and assigns it a value.
VARIANCE	Returns the amplitude variance of the specified trace, in measurement units.

Mass Memory Module Commands

Programming Commands (alphabetical index)

—A—

ACPACCL[_](NRM|FASTR|FASTS)|?;

Sets the adjacent channel power measurement speed to normal (NRM), faster (FASTR), or fastest (FASTS).

OUTPUT 718;"ACPACCL FASTR;"

Query Response: <number><LF with EOF>

OUTPUT 718;"ACPACCL?;"

ENTER 718;Acceleration\$

ACPALPHA[_]<number>|?;

Sets the adjacent channel power alpha weighting.

REAL Alphaweight

Alphaweight = .35

OUTPUT 718;"ACPALPHA";Alphaweight;"

Query Response: <number><LF with EOF>

OUTPUT 718;"ACPALPHA?;"

ENTER 718;Alpha_wt

ACPALTCH[_](0|1|2)|?;

Sets the number of alternate channel pairs to be used for an adjacent channel power measurement.

INTEGER Altchan

Altchan = 2

OUTPUT 718;"ACPALTCH";Altchan;"

Query Response: <number><LF with EOF>

OUTPUT 718;"ACPALTCH?;"

ENTER 718;Alt_ch

Programming Commands (alphabetical index)

ACPBRWID_<number><time units>|?;
Sets the cycle time of the burst signal when making adjacent channel power measurement.
REAL Burstperiod
Burstwidth = 20.0
OUTPUT 718;"ACPBRPER";Burstperiod;"MS;"
Query Response: <number><LF with EOI>
OUTPUT 718;"ACPBRPER?;"
ENTER 718;Burst_per

ACPBRWID_<number><time units>|?;
Sets the burst width for a gated method adjacent channel power measurement.
REAL Burstwidth
Burstwidth = 6.53
OUTPUT 718;"ACPBRWID";Burstwidth;"MS;"
Query Response: <number><LF with EOI>
OUTPUT 718;"ACPBRWID?;"
ENTER 718;Burst_wid

ACPBW_<number><frequency units>|?;
Sets the bandwidth of the channels as an active function for the ACPMEAS and ACPCOMPUTE commands.
REAL Channelbw
Channelbw = 8.5E6
OUTPUT 718;"ACPBW";Channelbw;"HZ;"
Query Response: <number><LF with EOI>
OUTPUT 718;"ACPBW?;"
ENTER 718;Chan_bw

Programming Commands (alphabetical index)

ACPCOMPUTE;

Performs the adjacent channel power computation on the designated signal without changing any instrument state settings.

```
OUTPUT 718;"ACPCOMPUTE;"
```

ACPFRQWT[_](RRCOS|OFF)|?;

Sets the frequency weighting for adjacent channel power measurements.

```
OUTPUT 718;"ACPFRQWT RRCOS;"
```

Query Response: (RRCOS|OFF)<LF with EOI>

```
OUTPUT 718;"ACPFRQWT?;"
```

```
ENTER 718;Fweight$
```

ACPGRAPH_(ON|OFF)|[_](1|0)|?;

Turns on or off a graphical representation of the adjacent power channel power ratio, for the selected channel bandwidth, as a function of the channel spacing.

```
OUTPUT 718;"ACPGRAPH ON;"
```

Query response: (1|0)<LF with EOI>

```
OUTPUT 718;"ACPGRAPH ?;"
```

```
ENTER 718;Graph_on
```

ACPLOWER?;

Returns power ratio result of the adjacent channel power measurement for the lower frequency channel.

Query Response: <number><LF with EOI>

```
OUTPUT 718;"ACPLOWER?;"
```

```
ENTER 718;Acp_low
```

Programming Commands (alphabetical index)

ACPMAX?;

Returns the maximum adjacent channel power of the adjacent channel power measurement.

Query Response: <number><LF with EOI>

```
OUTPUT 718;"ACPMAX?;"
```

```
ENTER 718;Acp_max
```

ACPMEAS;

Performs an automatic adjacent channel power measurement of a transmitter.

```
REAL Lower,Upper,Total_pwr,Max_acp
```

```
OUTPUT 718;"ACPMEAS;"
```

```
OUTPUT 718;"ACPLLOWER?;"
```

```
ENTER 718;Lower
```

```
OUTPUT 718;"ACPUPPER?;"
```

```
ENTER 718;Upper
```

```
OUTPUT 718;"ACPPWRTX?;"
```

```
ENTER 718;Total_pwr
```

```
OUTPUT 718;"ACPMAX?;"
```

```
ENTER 718;Max_acp
```

```
PRINT USING "K,K";"ACPUPPER= ",Upper
```

```
PRINT USING "K,K";"ACPLLOWER= ",Lower
```

```
PRINT USING "K,K";"ACPPWRTX= ",Total_pwr
```

```
PRINT USING "K,K";"ACPMAX= ",Max_acp
```

ACPMETHOD[_](ANALOG|PEAK|TWOBW|BURST|GATED)|?;

Selects the measurement method to be used for making adjacent channel power measurements.

```
OUTPUT 718;"ACPMETHOD BURST;"
```

Query Response: (ANALOG|PEAK|TWOBW|BURST|GATED)<LF with EOI>

```
OUTPUT 718;"ACPMETHOD?;"
```

```
ENTER 718;Acp_method$
```

Programming Commands (alphabetical index)

ACPMSTATE_(CURR|DFLT|?);

Sets the measurement state to a default or the current state.

```
OUTPUT 718;"ACPMSTATE CURR;"
```

Query Response: (CURR|DFLT)<LF with EOI>

```
OUTPUT 718;"ACPMSTATE?;"
```

```
ENTER 718;Meas_state$
```

ACPPWRTX?;

Returns the result of the total power transmitted calculation of the adjacent channel power measurement.

Query Response: <number><LF with EOI>

```
OUTPUT 718;"ACPPWRTX?;"
```

```
ENTER 718;Total_pwr
```

ACPRSLTS?;

Returns an array of adjacent channel power measurement data. The number of variables returned depends on the selected measurement method and number of alternate channels.

Query Response: <array of numbers><LF with EOI>

```
OUTPUT 718;"ACPALTCH 1;"
```

```
OUTPUT 718;"ACPMETHOD BURST;"
```

```
OUTPUT 718;"ACPMEAS;"
```

```
OUTPUT 718;"ACPRSLTS?;"
```

```
ENTER 718;Low0_random;Low0_impulse;Low0_weight;Low0_avg;
```

```
Up0_random;Up0_impulse;Up0_weight;Up0_avg
```

```
ENTER 718;Low1_random;Low1_impulse;Low1_weight;Low1_avg;
```

```
Up1_random;Up1_impulse;Up1_weight;Up1_avg
```

Programming Commands (alphabetical index)

ACPSP[_]<number><frequency units>|?;
Sets channel spacing as the active function for the ACPMEAS and
ACPCOMPUTE commands.
REAL Channelsp
Channelsp = 12.5E6
OUTPUT 718;"ACPSP";Channelsp;"HZ;"
Query Response: <number><LF with EOI>
OUTPUT 718;"ACPSP?;"
ENTER 718;Chan_sp

ACPT_<number><time units>|?;
Sets the T weighting for adjacent channel power measurements.
REAL Tweight
Tweight = 41
OUTPUT 718;"ACPT ";Tweight;"US;"
Query Response: <number><LF with EOI>
OUTPUT 718;"ACPT?;"
ENTER 718;T_weight

ACPUPPER?;
Returns power ratio result of the adjacent channel power measurement
for the upper frequency channel.
Query Response: <number><LF with EOI>
OUTPUT 718;"ACPUPPER?;"
ENTER 718;Upper_pwr

ADJALL;
Initiates the LO and IF alignment routines.
OUTPUT 718;"ADJALL;IP;"

Programming Commands (alphabetical index)

ADJCRT;

Turns on CRT adjustment patterns. Execute IP when adjustment is complete.

```
OUTPUT 718;"ADJCRT;"
```

ADJIF_(ON|OFF|FULL|CURR)[_](1|0)?;

Activates constant IF adjustment sequence.

Default is on.

```
OUTPUT 718;"ADJIF OFF;"
```

Query response: 1|0<LF with EOI>

```
OUTPUT 718;"ADJIF?;"
```

```
ENTER 718;Adj if
```

AMB_(ON|OFF|1|0)?;

Subtracts trace B from trace A and sends the result to trace A.

```
OUTPUT 718;"CLRW TRB;TS;VIEW TRB;TS;AMB ON;"
```

Query response: 1|0<LF with EOI>

```
OUTPUT 718;"AMB?;"
```

```
ENTER 718;Amb
```

AMBPL_(ON|OFF|1|0)?;

Subtracts trace B from trace A, adds the display line value to the difference, and sends the result to trace A.

```
OUTPUT 718;"CLRW TRB;TS;VIEW TRB;DL -50DBM;"
```

```
OUTPUT 718;"AMBPL ON;"
```

Query response: 1|0<LF with EOI>

```
OUTPUT 718;"AMBPL?;"
```

```
ENTER 718;Ambpl
```

AMPCOR[_](ON|OFF|1|0)?;

Turns amplitude correction function on and off.

```
OUTPUT 718;"AMPCOR ON;"
```

Query Response: (0|1)<LF with EOI>

```
OUTPUT 718;"AMPCOR?;"
```

Programming Commands (alphabetical index)

AMPCORDATA[_](<number><frequency units>,<number>DB|?);
Enters or queries the frequency-amplitude correction points.
REAL Freq1, Ampl1, Freq2, Ampl2
Freq1 = 1.0
Freq2 = 1.2
Ampl1 = .5
Ampl2 = .7
OUTPUT 718;"AMPCORDATA";freq1;"GHZ,";amp1;"DB,"
freq2;"GHZ,";amp2;"DB;"
Query Response: <number>,<number><LF with EOI>
OUTPUT 718;"AMPCORDATA?;"
ENTER 718;Ampcorfreq1,Ampcoramp1,Ampcorfreq2,Ampcoramp2

AMPCORRCL[_]<integer>;
Recalls a table of frequency-amplitude correction points from memory.
<integer>::=0 through 5
INTEGER Register
Register = 3
OUTPUT 718;"AMPCORRCL";Register;" ;"

AMPCORSAVE[_]<integer>;
Saves current table of frequency-amplitude correction points in memory.
<integer>::=0 through 5
INTEGER Register
Register = 3
OUTPUT 718;"AMPCORSAVE";Register;" ;"

AMPCORSIZE?;
Returns the number of frequency-amplitude correction points.
Query Response: <integer><LF with EOI>
INTEGER Ampcorpts
OUTPUT 718;"AMPCORSIZE?;"
ENTER 718; Ampcorpts

Programming Commands (alphabetical index)

ANNOT_(ON|OFF|1|0)|?;

Turns the display annotation on or off.

OUTPUT 718;"ANNOT OFF;"

Query response: 1|0<LF with EOI>

OUTPUT 718;"ANNOT?;"

ENTER 718;Annot

APB;

Adds trace A and trace B and sends the result to trace A.

OUTPUT 718;"VIEW TRA;CLR TRB;TS;VIEW TRB;"

OUTPUT 718;"APB;"

AT[_]<integer>DB)|_(UP|DN|EP|OA|MAN|AUTO)|?;

Specifies the RF input attenuation, in dB.

<integer>::=0 through 70

(0 through 60 for the 8564E/EC and 8565E/EC)

UP/DN increment::=10 dB

OUTPUT 718;"AT 30 DB;"

OUTPUT 718;"AT UP;"

Query response: <integer><LF with EOI>

OUTPUT 718;"AT AUTO;"

OUTPUT 718;"AT?;"

ENTER 718;Atten

AUNITS_(<amplitude units>|AUTO|MAN)|?;

Specifies the amplitude units for input, output and display.

OUTPUT 718;"AUNITS DBUV;"

OUTPUT 718;"AUNITS AUTO;"

Query response: <amplitude units><LF with EOI>

OUTPUT 718;"AUNITS?;"

ENTER 718;Units\$

Programming Commands (alphabetical index)

AUTOCP;

Auto-couples all controls.
OUTPUT 718;"AUTOCP;"

AXB;

Exchanges trace A and trace B.
OUTPUT 718;"AXB;"

—B—

BLANK_(TRA|TRB);

Stores and blanks the specified trace register.
OUTPUT 718;"BLANK TRB;"

BML;

Subtracts the display line from trace B and sends the result to trace B.
OUTPUT 718;"DL -30 DBM;CLR TRB;TS;"
OUTPUT 718;"BML;"

—C—

CARROFF_(TRA|TRB),?;

Measures carrier power when the burst is off.
Query Response: <number><LF with EOI>
OUTPUT 718;"CARROFF TRB,?;"
ENTER 718;Carroff_pwr

CARRON_(TRA|TRB),?;

Measures the average power of the carrier while the burst is turned on.
Query Response: <number><LF with EOI>
OUTPUT 718;"CARRON TRA,?;"
ENTER 718;Carron_pwr

Programming Commands (alphabetical index)

CF[_]<real><frequency units>[_(UP|DN|EP|OA)]?;
Specifies the center frequency. Default units are Hz.
UP/DN increment::=10 percent of span or step size
OUTPUT 718;"CF 2.750 GHZ;"
OUTPUT 718;"CF DN;"
Query response: <numeric data format><LF with EOI>
OUTPUT 718;"CF?;"
ENTER 718;Freq

CHANPWR_(TRA|TRB)<number><frequency units>;
Measures the channel power.
REAL Powerbw, Chan_pwr
Powerbw = 30
Query Response: <number><LF with EOI>
OUTPUT 718;"CHANPWR TRB, ";Powerbw;"KHZ,?;"
ENTER 718; Chan_pwr

CHANNEL_(UP|DN);
Changes the center frequency by one channel width.
OUTPUT 718;"CHANNEL UP;"

CHPWRBW<number><frequency units>[?];
Sets the channel power bandwidth.
REAL Powerbw
Powerbw = 30
OUTPUT 718; "CHPWRBW";Powerbw;"KHZ;"
Query Response: <number><LF with EOI>
OUTPUT 718;"CHPWRBW?;"
ENTER 718;Power_bw

CLRW_(TRA|TRB);
Clear-writes the specified trace register.
OUTPUT 718;"CLRW TRA;"

Programming Commands (alphabetical index)

CNVLOSS[_]<real>DB|_(|UP|DN|EP|OA)|?;
Specifies the conversion loss of an external mixer used to extend the analyzer frequency range.

UP/DN increment::=0.1 dB

OUTPUT 718;"CNVLOSS 24.5 DB;"

OUTPUT 718;"CNVLOSS DN;"

Query response: <numeric data format><LF with EOI>

OUTPUT 718;"CNVLOSS?;"

ENTER 718;Mixer_loss

CONTS;

Selects continuous sweep mode.

Selected with IP.

OUTPUT 718;"SP 10 MHZ;CONTS;"

COUPLE_ (AC|DC|OA)|?;

Sets the input coupling to ac or dc coupling. Default is ac.

(Not available with an 8563E/EC, 8564E/EC, or 8565E/EC, which are always dc coupled.)

OUTPUT 718;"COUPLE AC;"

Query response: AC|DC<LF with EOI>

OUTPUT 718;"COUPLE?;"

ENTER 718;Couple\$

—D—

DELMKBW_ (TRA|TRB)<number>,?;

Returns the bandwidth of the selected percent of the power between the delta markers.

REAL Percentocc

Percentocc = 90

OUTPUT 718;"DELMKBW TRA";Percentocc;" ,?;"

Query Response: <number><LF with EOI>

OUTPUT 718;"DELMKBW TRA";Percentocc;" ,?;"

ENTER 718;Delmkr_pwr bw

Programming Commands (alphabetical index)

DEMODO(_FM|AM|OFF)|?;

Selects FM or AM demod and turns demodulation off.

OUTPUT 718;"DEMODO FM;"

OUTPUT 718;"DEMODO OFF;"

Query response: (FM|AM|OFF)<LF with EOI>

OUTPUT 718;"DEMODO?;"

ENTER 718;Demod\$

DEMODOAGC_(ON|OFF)|[_](|1|0)|?;

Turns the demodulation automatic gain control (AGC) on or off.

IP turns AGC off.

OUTPUT 718;"DEMODOAGC ON;"

Query response: 1|0<LF with EOI>

OUTPUT 718;"DEMODOAGC?;"

ENTER 718;Demodagc

DEMODOT[_]<real><time units>|[_](UP|DN|EP|OA)|?;

Selects the time the sweep pauses at marker for demodulation of signal.

UP/DN increment::=1,2,5,10 sequence

OUTPUT 718;"DEMODO T 10 SC;"

Query response: <numeric data format><LF with EOI>

OUTPUT 718;"DEMODO T?;"

ENTER 718;Delay

DET_(POS|NEG|NRM|SMP)|?;

Selects the specified analyzer video detection.

OUTPUT 718;"DET POS;"

Query response: (POS|NEG|NRM|SMP)<LF with EOI>

OUTPUT 718;"DET?;"

ENTER 718;Det\$

Programming Commands (alphabetical index)

DL[_]<real><amplitude units>|_(UP|DN|ON|OFF|EP|OA)|?;

Specifies a line level that is displayed on the CRT.

UP/DN increment::=1 vertical division

OUTPUT 718;"DL -25 DBM;"

Query response: <numeric data format><LF with EOI>

OUTPUT 718;"DL?;"

ENTER 718;Line

DLYSWP_(<number><time units>|ON|OFF)|[_](1|0)|?;

Delays the start of the sweep until the specified time elapses after the trigger event. Querying DLYSWP either returns the value of sweep delay length in seconds, or a "0" indicating the delay sweep is turned off.

OUTPUT 718;"DLYSWP 10US;"

Query Response: (<number>|0)<LF with EOI>

OUTPUT 718;"DLYSWP?;"

ENTER 718;Sweep_dly

DONE?;

This command is a synchronizing function that sends a 1 to the controller after the command list has been executed. For example, if TS (take sweep) precedes DONE, completion of a sweep is assured before the 1 is returned.

OUTPUT 718;"SP 100 MHZ;TS;DONE?;"

Query response: 1<LF with EOI>

OUTPUT 718;"SP 100 MHZ;TS;DONE?;"

ENTER 718;Done

Programming Commands (alphabetical index)

—E—

ERR?;

Returns a list of error numbers to the controller. Positive numbers are error codes. An error code of 0 means there are no errors.

Query response: <integer>,<LF with EOI>

```
OUTPUT 718;"ERR?;"
ENTER 718; Err$
PRINT Err$
```

ET?;

Returns the elapsed time of operation in hours. Reset by Hewlett-Packard.

Query response: <numeric data format><LF with EOI>

```
OUTPUT 718;"ET?;"
ENTER 718;Time
```

EXTMXR_(PRE|UNPR)|?;

Specifies external mixing mode.

```
OUTPUT 718;"EXTMXR PRE;"
```

Query response: PRE|UNPR<LF with EOI>

```
OUTPUT 718;"EXTMXR?;"
ENTER 718;Mxrmode$
```

—F—

FA[_]<real><frequency units>|_(UP|DN|EP|OA)|?;

Specifies the start frequency. Default units are Hz.

UP/DN increment::=10 percent of span

```
OUTPUT 718;"FA 150 KHZ;"
```

Query response: <numeric data format><LF with EOI>

```
OUTPUT 718;"FA?"
ENTER 718;Startfreq
```

Programming Commands (alphabetical index)

FB[_]<real><frequency units>|_(UP|DN|EP|OA)|?;
Specifies the stop frequency. Default units are Hz.
UP/DN increment::=10 percent of span
OUTPUT 718;"FB 540 MHZ;"
Query response: <numeric data format><LF with EOI>
OUTPUT 718;"FB?;"
ENTER 718;Stopfreq

FDIAG_(LO|SMP|HARM|MROLL|POSTSC|RAWOSC),?;
Returns the specified frequency diagnostic information.
OUTPUT 718;"FDIAG HARM,?;"
Query response: <numeric data format><LF with EOI>
OUTPUT 718;"FDIAG L0,?;"
ENTER 718;Lo_freq

FDSP_OFF|?;
Turns all frequency related annotation off. Power-on or preset is the only way to turn frequency annotation back on.
OUTPUT 718;"FDSP OFF;CF 12.25 GHZ;"
Query response: (1|0)<LF with EOI> (1 = frequency annotation blanked)
OUTPUT 718;"FDISP?;"
ENTER 718;Disp

FFT_<trace destination>,<trace source>,<trace window>;
Performs a discrete Fourier transform on the source trace. Use to transform zero-span AM information into the frequency domain.
OUTPUT 718;"TWINDOW TRA,UNIFORM;TS;"
OUTPUT 718;"FFT TRA,TRB,TRA;"

Foffset[_]<real><frequency units>|_(UP|DN|EP|OA)|?;
Specifies the frequency offset for all absolute frequency readouts such as center frequency. Default units are Hz.
UP/DN increment::=20 percent of span
OUTPUT 718;"Foffset 25 MHZ;"
Query response: <numeric data format><LF with EOI>
OUTPUT 718;"Foffset?;"
ENTER 718;Offset

Programming Commands (alphabetical index)

FREF_(INT|EXT)?;

Specifies the frequency reference source.

```
OUTPUT 718;"FREF INT;"
```

Query response: (INT|EXT)<LF with EOI>

```
OUTPUT 718;"FREF ?;"
```

```
ENTER 718;Freqref$
```

FS;

Selects the full frequency span as defined by the instrument.

```
OUTPUT 718;"CF 1.5 GHZ;FS;"
```

FULBAND_(K|A|Q|U|V|E|W|F|D|G|Y|J);

Selects the full frequency span for the external mixing frequency band the analyzer is currently tuned to (for example, 26.5 to 40.0 GHz equals band A).

```
OUTPUT 718;"MXRMODE EXT;FULBAND Q;"
```

Band	Frequency Range	Mixing Harmonic ¹	Conversion Loss
K	18.6—26.5 GHz	6—	30 dB
A	26.5—40.0 GHz	8—	30 dB
Q	33.0—50.0 GHz	10—	30 dB
U	40.0—60.0 GHz	10—	30 dB
V	50.0—75.0 GHz	14—	30 dB
E	60.0—90.0 GHz	16—	30 dB
W	75.5—110.0 GHz	18—	30 dB
F	90.0—140.0 GHz	24—	30 dB
D	110.0—170.0 GHz	30—	30 dB
G	140.0—220.0 GHz	36—	30 dB
Y	170.0—260.0 GHz	44—	30 dB
J	220.0—325.0 GHz	54—	30 dB

¹ For unpreselected external mixers.

Programming Commands (alphabetical index)

—G—

GATE_(ON|OFF)|[_](1|0)?;

Turns on or off the video-gating function. When the video-gating function is turned on, the spectrum analyzer activates the video gate circuitry according to the parameters controlled by gate length (GL), gate delay (GD), and the gate trigger input.

OUTPUT 718;"GATE ON;"

Query response: (1|0)<LF with EOI>

OUTPUT 718;"GATE ?;"

ENTER 718;Gate_on

GATECTL_(EDGE|LEVEL)?;

Selects between the edge and the level mode for video-gate function. In the edge mode, a specified trigger edge starts the gate delay timer that in turn starts the gate length timer. In the level mode, the gate follows the trigger input level.

OUTPUT 718;"GATECTL LEVEL;"

Query Response: (EDGE|LEVEL)<LF with EOI>

OUTPUT 718;"GATECTL?;"

ENTER 718;Gate_cntrl\$

GD_<number><time units>|?;

Sets the delay time from when the gate trigger occurs to when the gate is turned on. GD applies only if GATECTL is set to EDGE.

OUTPUT 718;"GD 20US;"

Query Response: <number><LF with EOI>

OUTPUT 718;"GD?;"

ENTER 718;Gate_delay

Programming Commands (alphabetical index)

GL_<number><time units>|?;

Sets the length of time the video gate is turned on. GL applies only if GATECTL is set to EDGE.

OUTPUT 718;"GL 90US;"

Query Response: <number><LF with EOI>

OUTPUT 718;"GL?;"

ENTER 718;Gat_length

GP_(NEG|POS)|?;

Sets the polarity (positive or negative) for the gate trigger.

OUTPUT 718;"GP POS;"

Query Response:(NEG|POS)<LF with EOI>

OUTPUT 718;"GP?;"

ENTER 718;Gate_pol\$

GRAT_(ON|OFF)|[_](1|0)?;

Turns the graticule on or off. IP turns on the graticule.

OUTPUT 718;"GRAT OFF;"

Query response: (1|0)<LF with EOI>

OUTPUT 718;"GRAT?;"

ENTER 718;Grat

—H—

HD;

Holds or disables data entry and blanks the active function readout.

OUTPUT 718;"CF 14 GHZ;TS;HD;"

Programming Commands (alphabetical index)

HNLOCK[_]<integer>|_-(ON|OFF|UP|DN|OA|EP)|?;

Locks the specified harmonic number to prevent multi-harmonic sweeps.

<integer>::= 6 through 54

UP/DN increment::=1

OUTPUT 718;"MXRMODE EXT;HNLOCK 8;"

Query response: <integer><LF with EOI>

OUTPUT 718;"HNLOCK ?;"

ENTER 718;Harmonic_lock

HNUNLK;

Unlocks the harmonic number.

OUTPUT 718;"HNUNLK;CF 65 GHZ;HNLOCK ON;"

—I—

ID?|_OA;

Returns the model number and any options installed.

DIM ID\$ [50]

OUTPUT 718;"ID?;"

Query response: <string data field>,<LF with EOI>

OUTPUT 718;"ID?;"

ENTER 718;Id\$

IDCF;

Sets the center frequency (CF) to the frequency of the signal identified by the SIGID function. *Only available with firmware revisions \leq 920528 or with Option 008.*

OUTPUT 718;"MKPK HI;SIGID AUTO;IDCF;"

Programming Commands (alphabetical index)

IDFREQ?|_OA;

Returns the frequency of the identified signal to the controller. Returns a 0 if invalid signal identification. *Only available with firmware revisions ≤920528 or with Option 008.*

Query response: <number><LF with EOI>

```
OUTPUT 718;"SIGID AUTO;IDFREQ?;"
```

```
ENTER 718; Sig_freq
```

IP;

Sets instrument parameters to their preset values.

```
OUTPUT 718;"IP;CF 100MHZ;SP 1MHZ;TS;"
```

—L—

LG[_]<integer>DB|_(UP|DN|EP|OA)|?;

Specifies the scale of the logarithmic display in 10, 5, 2, or 1 dB per division. Default units are dB, and 10 dB per division is selected with IP.

<integer>::=1|2|5|10

UP/DN increment::=1, 2, 5, 10 sequence

```
OUTPUT 718;"LG 2 DB;"
```

```
OUTPUT 718;"IP;LG DN DN;"
```

Query response: <integer><LF with EOI>

A query response of zero indicates a linear scale.

```
OUTPUT 718;"LG ?;"
```

```
ENTER 718;Log_scale
```

LN;

Selects the linear scale.

```
OUTPUT 718;"RL -30 DBM;LN;"
```

Programming Commands (alphabetical index)

—M—

MBIAS[_]<real>(A|MA|UA)|_(ON|OFF|UP|DN|EP|OA)|?;
Selects the bias level for external mixers that require diode bias for efficient mixer operation.
<real>::= -10 to 10
UP/DN increment::=0.01 mA
OUTPUT 718;"MXRMODE EXT;HNLOCK A;MBIAS 20 MA;"
Query response: <numeric data format><LF with EOI>
OUTPUT 718;"MBIAS ?;"
ENTER 718;Mixer_bias

MEANPWR_(TRA|TRB),<number>DB,?;
Measures the average power of the carrier while the burst is turned on and allows you to define the carrier on amplitude range, in decibels below the peak value of the trace.
REAL Onrange
Onrange = 20
OUTPUT 718;"MEANPWR TRB,";Onrange;"DB,?;"
Query Response: <number><LF with EOI>
OUTPUT 718;"MEANPWR TRB,";Onrange;"DB,?;"
ENTER 718;Carr_onpwr

MEAS?;
Returns the current sweep status.
Query Response: (SNGLS|CONTS)<LF with EOI>
OUTPUT 718;"MEAS?;"
ENTER 718;Sweep\$

Programming Commands (alphabetical index)

MINH_(TRA|TRB);

Similar to MXMH except that the minimum trace values are stored.
OUTPUT 718;"CLRW TRA;MINH TRA;"

MKA?|_OA;

Returns the amplitude of the active marker. Default units are dBm.
Note: Because MKA returns only a numeric value, know the amplitude units in use (see AUNITS).

Query response: <numeric data format><LF with EOI>

OUTPUT 718;"SGLS;TS;MKPK HI;MKA?;"
ENTER 718;Amptd

MKBW_<negative integer>,?;

Returns the signal bandwidth at the desired power level below the on-screen marker (if a marker is present) or below the signal peak. The power level units are dB.

Query response: <numeric data format>

OUTPUT 718;"CF 300 MHZ;SP 100MHZ;SGLS;"
OUTPUT 718;"TS;MKPK HI;"
OUTPUT 718;"MKBW -3,?;"
ENTER 718;Mkrbw

MKCF;

Moves the active marker to the center frequency.

OUTPUT 718;"CF 600 MHZ;SP 1 GHZ;"
OUTPUT 718;"TS;MKPK HI;MKCF;TS;"

Programming Commands (alphabetical index)

MKCHEDGE;

Moves the delta markers to ± 0.5 channel widths from the center frequency.

```
OUTPUT 718;"MKCHEDGE;"
```

MKD[[-]<real><frequency units>|_(UP|DN|EP|OA)|?];

Places a second marker at the specified frequency from the active marker. Frequency may be positive or negative. Default units are Hz. In zero frequency span the units are time.

UP/DN increment::=10% of span

```
OUTPUT 718;"CF 450 MHZ;SP 400 MHZ;"
```

```
OUTPUT 718;"TS;MKPK HI;MKD 300 MHZ;"
```

Query response: <numeric data format><LF with EOI>

```
OUTPUT 718;"MKPK HI;MKD;MKPK NH:MKD?;"
```

```
ENTER 718;Marker_del
```

MKDELCHBW(TRA|TRB);

Sets the channel power bandwidth to difference between the delta markers.

```
OUTPUT 718;"MKDELCHBW TRA;"
```

MKDR[[-]<real>(<frequency units>|<time units>)|_(EP|OA)|?];

Reads the reciprocal of marker delta, which is the time period between markers. In zero frequency span the units are frequency.

```
OUTPUT 718;"TS;MKPK HI;MKD;MKPK NH;MKDR;"
```

Query response: <numeric data format><LF with EOI>

```
OUTPUT 718;"TS;MKPK HI;MKD;MKPK NH;MKDR?;"
```

```
ENTER 718;Period
```

Programming Commands (alphabetical index)

MKF[_]<real><frequency units>|_(EP|OA)|?;

Specifies the frequency of the active marker. Default units are Hz.

OUTPUT 718;"CF 450 MHZ;SP 400 MHZ;MKF 600 MHZ;"

Query response: <numeric data format><LF with EOI>

OUTPUT 718;"TS;MKPK HI;MKF?;"

ENTER 718;Mfreq

MKFC_(ON|OFF);

Counts the marker frequency for a more accurate readout of the marker frequency. The resolution is determined by the MKFCR command.

OUTPUT 718;"MKPK HI;MKFC ON;TS;MKF?;"

ENTER 718;Freq_count

MKFCR[_]<real><frequency units>|_(EP|OA)|?;

Specifies the resolution of the marker frequency counter.

OUTPUT 718;"MKFCR 100 HZ;MKFC ON;"

Query response: <numeric data format><LF with EOI>

OUTPUT 718;"MKFCR?;"

ENTER 718;Count_res

MKMCF;

Moves the midpoint of the delta markers to the center frequency.

OUTPUT 718;"MKMCF;"

MKMIN;

Moves the active marker to the minimum signal detected.

OUTPUT 718;"TS;MKPK HI;MKD;MKMIN;"

Programming Commands (alphabetical index)

MKN[[_]<real>(<frequency units>| <time units>)|_(UP|DN|EP|OA)|?];

Moves the active marker to the specified frequency. Default units are Hz.

UP/DN increment::=10 percent of span

OUTPUT 718;"TS;MKN;"

OUTPUT 718;"CF 100 MHZ;SP 100 MHZ;TS;MKN 75 MHZ;"

Query response: <numeric data format><LF with EOI>

OUTPUT 718;"MKPK HI;MKN?;"

ENTER 718;Marker

MKNOISE_(ON|OFF)|[(1|0)]?;

Calculates the average value at the marker, normalized to a 1 Hz bandwidth, after correction for resolution bandwidth and detection mode (log or linear).

OUTPUT 718;"TS;MKMIN;MKNOISE ON;MKA?;"

ENTER 718;Amptd

Query response: (1|0)<LF with EOI>

OUTPUT 718;"MKNOISE?;"

ENTER 718;Mknoise

MKOFF[_ALL];

Turns the active marker, or all markers, off.

OUTPUT 718;"MKOFF;"

MKPK[_(HI|NH|NR|NL)];

Moves the active marker to the maximum signal detected or to the next highest, next right, or next left signal detected. Marker defaults to maximum signal detected.

OUTPUT 718;"TS;MKPK HI;"

OUTPUT 718;"TS;MKPK HI;MKPK NL;"

OUTPUT 718;"TS;MKPK;"

Programming Commands (alphabetical index)

MKPT[_]<real>DBM|_(UP|DN|EP|OA)|?;
Specifies the marker peak threshold.
UP/DN increment::=10 dB
OUTPUT 718;"MKPT -95 DBM;"
OUTPUT 718;"AUNITS DBUV;MKPT UP;"
Query response: <numeric data format><LF with EOI>
OUTPUT 718;"MKPT?;"
ENTER 718;Peak_thresh

MKPX[_]<real>DB|_(UP|DN|EP|OA)|?;
Specifies the minimum excursion for peak identification. Default units are dB. IP selects 6 dB for minimum excursion.
<real>::=values 0.0 through 30.0
UP/DN increment::=1 vertical division of the display
OUTPUT 718;"MKPX 3DB;TS;MKPK HI;"
Query response: <numeric data format><LF with EOI>
OUTPUT 718;"MKPX?;"
ENTER 718;Peak_ex

MKRL;
Moves the active marker to the reference level.
OUTPUT 718;"TS;MKPK HI;MKRL;TS;"

MKSP;
Moves the marker delta frequency into the frequency span.
OUTPUT 718;"TS;MKPK HI;MKD;MKPK NH;MKSP;TS;"

MKSS;
Moves the marker frequency into the center frequency step size.
OUTPUT 718;"TS;MKPK HI;MKSS;CF UP UP;"

Programming Commands (alphabetical index)

MKT[_]<real><time units>|_OA|?;

Sets the marker to the position corresponding to the amount of time from the beginning of sweep.

OUTPUT 718;"ST 2 SEC;MKT 1.6 SEC;"

Query response: <real><LF with EOI>

OUTPUT 718;"MKT ?;"

ENTER 718;Mkr_time

MKTRACK_(ON|OFF|OA)|[_](1|0)|?;

Turns the marker signal track ON or OFF.

OUTPUT 718;"CF 300 MHZ;SP 100 MHZ;"

OUTPUT 718;"MKPK HI;MKTRACK ON;"

OUTPUT 718;"SP 100 KHZ;MKTRACK OFF;"

Query response: (1|0)<LF with EOI>

OUTPUT 718;"MKTRACK?;"

ENTER 718;Track\$

ML[_]<integer>DBM|_(UP|DN|EP|OA)|?;

Specifies the mixer level. Default units are dBm.

<integer>::=-10 through -80

UP/DN increment::=10 dB

OUTPUT 718;"ML - DBM;"

OUTPUT 718;"ML 60 DBUV;"

OUTPUT 718;"ML 10 DBMV;"

Query response: <integer><LF with EOI>

OUTPUT 718;"ML?;"

ENTER 718;Mixer_lvl

MXMH_(TRA|TRB);

Updates each trace element with the maximum level detected.

OUTPUT 718;"CLR W TRA;CLR W TRB;MXMH TRA;"

Programming Commands (alphabetical index)

MXRMODE_(INT|EXT)|?;

Specifies an external or internal mixer mode.

```
OUTPUT 718;"MXRMODE EXT;"
```

Query response: (INT|EXT)<LF with EOI>

```
OUTPUT 718;"MXRMODE?;"
```

```
ENTER 718; Mode$
```

—N—

NORMLIZE_(ON|OFF|OA)|[_](1|0)|?;

Activates the normalization routine for stimulus-response measurements.

Trace B is subtracted from trace A, offset by the normalized reference level (NRL), and the result is sent to trace A. See also STOREOPEN and STORETHRU.

!assumes a valid reference trace is stored

```
OUTPUT 718;"NORMLIZE ON;TS;DONE?;"
```

```
ENTER 718;Done
```

Query response: <numeric data format><LF with EOI>

```
OUTPUT 718;"NORMLIZE?;"
```

```
ENTER 718;Normalized
```

NRL[_]<real>DB|?;

Sets the normalized reference level.

```
OUTPUT 718;"IP;SNGLS;"
```

```
OUTPUT 718;"NRL -10DB;TS;DONE?;"
```

```
ENTER 718;Done
```

```
END
```

Query response: <numeric data format><LF with EOI>

```
OUTPUT 718;"NRL?;"
```

```
ENTER 718;Nref_lvl
```

Programming Commands (alphabetical index)

NRPOS[_]<real>|_(UP|DN|EP|OA)|?;
Adjusts the normalized reference position.
OUTPUT 718;"IP;SNGLS;"
OUTPUT 178;"NRPOS 5;TS;DONE?;"
ENTER 718;Done
Query response: <numeric data format><LF with EOI>
OUTPUT 718;"NRPOS?;"
ENTER 718;Pos

—0—

OCCUP_<number>|?;
Enters desired percentage of occupied power. The PWRBW command is usually used to set the percentage.
REAL Percentpwr
Percentpwr = 95
OUTPUT 718;"OCCUP";Percentpwr;" "
Query Response: <number><LF with EOI>
OUTPUT 718;"OCCUP?;"
ENTER 718;Percentpwr

OP?|_OA;
Returns the parameters which represent the dimensions of the lower-left and upper-right vertices of the analyzer display in plotter units.
Order of response is P1x, P1y, P2x, and P2y.
Default is "72, 16, 712, 766;"
Query response: <integer>,<LF with EOI>
OUTPUT 718;"OP?;"
ENTER 718;P1x,P1y,P2x,P2y

Programming Commands (alphabetical index)

—P—

PLOT[_P1x,P1y,P2x,P2y];

Plots the analyzer display on any GPIB plotter. P1x and P1y::=plotter dependent values that specify the lower left plotter dimension. P2x and P2y::=plotter dependent values that specify the upper-right plotter dimension.

Default is current plotter P1, P2 settings.

```
DIM Param_string$[200]
```

```
Sel_code=7
```

```
Plt_addr=5
```

```
Sa_addrs=18
```

```
Param_string$=VAL$(P1x)&" , "VAL$(P1y)&" , "VAL$(P2x)&" , "  
VAL$(P2y)&" ; "
```

```
OUTPUT 718;"PLOT "Param_string$
```

```
SEND Sel_code;UNT UNL LISTEN Plt_addr TALK Sa_addrs DATA
```

PLOTORG_(DSP|GRT|OA)|?;

Specifies whether plotter P1, P2 settings are the origin for the graticule or the entire spectrum analyzer display. Allows plotting trace data on paper with preprinted graticule lines.

```
OUTPUT 718;"PLOTORG GRT;PLOT;"
```

```
SEND Sel_code;UNT UNL LISTEN Plt_addr TALK Sa_addrs DATA
```

Query response: (DSP|GRT)<LF with EOI>

```
OUTPUT 718;"PLOTORG?;"
```

```
ENTER 718;Origin$
```

PLOTSRC_(ALL|TRA|TRB|GRT|ANNT|OA)|?;

Specifies the source for PLOT.

Default is ALL.

```
OUTPUT 718;"PLOTORG GRT;PLOTSRC TRA;"
```

```
OUTPUT 718;"PLOTORG DSP;PLOTSRC ALL;"
```

```
OUTPUT 718;"PLOTORG GRT;PLOTSRC ANNT;PLOTSRC TRB;"
```

Query response: (ALL|TRA|TRB|GRT|ANNT)<LF with EOI>

```
OUTPUT 718;"PLOTSRC?;"
```

```
ENTER 718;Source$
```

5-72 Programming Reference

Programming Commands (alphabetical index)

PP;

Peaks the preselector for internal mixing or preselected external mixing only. Not available for 8560E/EC with Option 002.

```
OUTPUT 718;"CF 5 GHZ;SP 100 MHZ;  
OUTPUT 718;"TS;MKPK HI;MKCF;SP 10 MHZ;TS;PP;"
```

PRINT[-(1|0)];

Sends the display contents to a printer. Select 0 for a monochrome printer, 1 for a color format (for HP PaintJet or compatible, printer).

```
Sel_code=7  
Prt_addrs=1  
Sa_addrs=18  
OUTPUT 718;"PRINT 0;"  
SEND Sel_code;UNT UNL LISTEN Prt_addrs TALK Sa_addrs DATA
```

PSDAC[-<integer>|-(UP|DN|EP|OA)]?;

Specifies the preselector peak DAC setting.

<integer>::=0 through 255

UP/DN increment::=1

```
OUTPUT 718;"PSDAC 35;"
```

Query response: <integer><LF with EOI>

```
OUTPUT 718;"PSDAC?;"
```

```
ENTER 718;Presel_dac
```

PSTATE_(ON|OFF|OA)|[-](1|0)?;

Protects the saved states (save lock).

```
OUTPUT 718;"SAVES 2;PSTATE ON;"
```

```
OUTPUT 718;"PSTATE OFF;SAVES 4;"
```

Query response: (1|0)<LF with EOI>

```
OUTPUT 718;"PSTATE ?;"
```

```
ENTER 718;Pstate
```

PWRBW_<trace source>(,|-)<real>;?

Returns the bandwidth equal to the specified percentage of total power in a trace.

Query response: <real><LF with EOI>

```
OUTPUT 718;"PWRBW TRA,99,?;"
```

```
ENTER 718;Pwrbw
```

Programming Commands (alphabetical index)

—R—

RB[_]<real><frequency units>|_(UP|DN|EP|OA|AUTO|MAN)|?;

Specifies the resolution bandwidth.

<real>::= 10 Hz to 2 MHz

UP/DN increment::= 1, 3, 10 sequence

OUTPUT 718;"SP 1 MHZ;RB 1 MHZ;TS;"

Query response: <numeric data format><LF with EOI>

OUTPUT 718;"RB UP UP;RB?;"

ENTER 718;Res_bw

RBR[_]<real>|_(UP|DN|EP|OA)|?;

Specifies the ratio between the resolution bandwidth and the frequency span. If the span is changed, the resolution bandwidth will change to maintain the ratio.

<real>::=0.002 to 0.100

UP/DN increment::= 2, 5, 10 sequence

OUTPUT 718;"RBR .3;SP 100KHZ;TS;"

Query response: <numeric data format><LF with EOI>

OUTPUT 718;"RBR DN DN DN;RBR ?;"

ENTER 718;Rbw_ratio

RCLOSCAL;

Recalls averaged open/short reference trace data into trace B.

!assume a valid reference trace is stored

OUTPUT 718;"IP;"

OUTPUT 718;"RCLSOCAL;TS;DONE?;"

ENTER 718;Done

OUTPUT 718;"NORMLIZE ON;TS;DONE?;"

ENTER 718;Done

LOCAL 718

Programming Commands (alphabetical index)

RCLS[_]<integer>|_(LAST|PWRON);

Recalls a previously saved state (stored in registers 0 through 9), the last instrument state, or the power-on state.

<integer>::=0 through 9

```
OUTPUT 718;"IP;RCLS 2;"
```

```
OUTPUT 718;"CF 10MHZ;SP 1MHZ;TS;IP;RCLS LAST;"
```

RCLT_(TRA|TRB),<integer>;

Recalls a previously saved trace stored in registers 0 through 7.

<integer>::= 0 through 7

```
OUTPUT 718;"CLRW TRA;VIEW TRB;"
```

```
OUTPUT 718;"RCLT TRB,4;"
```

RCLTHRU;

Recalls a thru-reference trace into trace B.

!assumes a valid thru trace is stored.

```
OUTPUT 718;"RCLTHRU;TS;DONE?;"
```

```
ENTER 718;Done
```

```
OUTPUT 718;"NORMLIZE ON;TS;DONE?;"
```

```
ENTER 718;Done
```

REV?;

Returns the firmware revision number of the analyzer. Number returned is in the date format of "YYMMDD".

Query response: <numeric data format><LF with EOI>

```
OUTPUT 718;"REV?;"
```

```
ENTER 718;Revision
```

RL[_]<real><amplitude units>|_(UP|DN|EP|OA)|?;

Specifies the reference level or range level. Default units are dBm.

UP/DN increment::=Log scale/div or 10 dB in linear scale

```
OUTPUT 718;"CF 300MHZ;SP 1MHZ;RL -10DBM;TS;"
```

Query response: <numeric data format><LF with EOI>

```
OUTPUT 718;"TS;MKPK HI;MKRL;TS;"
```

```
ENTER 718;Ref_lvl
```

Programming Commands (alphabetical index)

RLCAL[_]<integer>|?;

Calibrates reference level.

<integer>::= -528 through +528

(-33 through +33 for firmware revisions ≤920528)

OUTPUT 718;"RLCAL ";Rl_cal

Query response: <integer><LF with EOI>

OUTPUT 718;"RLCAL ?;"

ENTER 718;Rl_cal

ROFFSET[_]<real>DB|_(UP|DN|EP|OA)|?;

Specifies the reference level offset. Default units are dB.

UP/DN increment::= Log scale/div or 10 dB in linear scale

OUTPUT 718;"ROFFSET -20DB;"

Query response: <numeric data format><LF with EOI>

OUTPUT 718;"ROFFSET?;"

ENTER 718;Ref_offset

RQS[_]<integer>|_OA|?;

Specifies a mask which allows the bits that are not masked for a service request. The bits are defined in Chapter 7 of the user's guide.

<integer>::= 0 through 255

OUTPUT 718;"RQS 16;"

OUTPUT 718;"RQS 4;"

OUTPUT 718;"RQS 20;"

Query response: returns the decimal weighting of the status byte bits which are enabled during a service request, followed by LF and EOI.

OUTPUT 718;"RQS?;"

ENTER 718;Rqs

—S—

SAVES[_]<integer>|_PWRON;

Saves the current state of the analyzer in the specified state register.

<integer>::= 0 through 9

OUTPUT 718;"CF 20MHZ;SAVES 3;IP;"

5-76 Programming Reference

Programming Commands (alphabetical index)

SAVET_(TRA|TRB),<integer>;

Saves the current trace of the analyzer in the specified trace register.

<integer>::= 0 through 7

OUTPUT 718;"CLRWB TRB;TS;SAVET TRB,4;"

SER?|_OA;

Returns the serial number of the spectrum analyzer to the controller.

Query response: <text><LF with EOI>

OUTPUT 718;"SER?;"

ENTER 718;Serial_number\$

SIGID[_](AUTO|MAN|OFF|OA)|?;

Identifies signals for the external mixing frequency bands. *Only available with firmware revisions ≤920528 or with Option 008.*

OUTPUT 718;"TS;MKPK HI;MKRL;SIGID AUTO;"

Query response: (0|1)<LF with EOI> (where 0 is OFF or AUTO, 1 is MAN)

OUTPUT 718;"SIGID?;"

ENTER 718;Status

SNGLS;

Selects single sweep mode.

OUTPUT 718;"IP;CF 100MHZ;SP 1MHZ;SNGLS;TS;"

SP[_]<real><frequency units>[_](FULL|ZERO|LAST|UP|DN|EP|OA)|?;

Specifies the frequency span. Default units are Hz.

UP/DN increment::=1,2,5 sequence

OUTPUT 718;"CF 10MHZ;SP DN DN;"

OUTPUT 718;"TS;MKPK HI;MKTRACK ON;SP 100KHZ;TS;MKTRACK OFF;"

Query response: <numeric data format><LF with EOI>

OUTPUT 718;"SP UP UP;SP?;"

ENTER 718;Span

Programming Commands (alphabetical index)

SQUELCH[_]<real><amplitude units>|_(ON|OFF|UP|DN|EP|OA)|?;

Controls the squelch for demodulation.

UP/DN increment::= Log scale/div or 10 dB in linear scale

OUTPUT 718;"DEM0D AM;SQUELCH -80 DBM;"

Query response: <numeric data format><LF with EOI>

OUTPUT 718;"SQUELCH?;"

ENTER 718;Squelch

SRCALC_(INT|EXT|OA)|?;

Selects internal or external leveling. For use with the 8560E/EC Option 002 tracking generator.

OUTPUT 718;"IP;SNGLS;TS;CF 300MHZ;SP 1MHZ;"

OUTPUT 718;"SRCALC EXT;"

Query response: (INT|EXT)<LF with EOI>

OUTPUT 718;"SRCALC?;"

ENTER 718;Alc\$

SRCCRSTK[_]<integer>|_(UP|DN|EP|OA)|?;

Adjusts the coarse tuning of the 8560E/EC Option 002 Tracking Generator oscillator.

<integer>::= 0 to 255

OUTPUT 718;SCRPWR 0N;SWPCPL SR;RB 10KHZ;"

OUTPUT 718;"TS:DONE?;"

Enter 718;Done

OUTPUT 718;"SRCCRSTK EP;"

PAUSE

Query response: <integer><LF with EOI>

OUTPUT 718;"SRCCRSTK?;"

ENTER 718;Tuning

Programming Commands (alphabetical index)

SRCFINTK[_]<integer>|_(UP|DN|EP|OA)|?;

Adjusts the fine tuning of the 8560E/EC Option 002 tracking generator oscillator.

<integer> ::= 0 to 255

```
OUTPUT 718;SRCPWR ON;SWPCPL SR;RB 10KHZ;"
```

```
OUTPUT 718;"TS:DONE?;"
```

```
Enter 718;Done
```

```
OUTPUT 718;"SRCFINTK EP;"
```

```
PAUSE
```

Query response: <integer><LF with EOI>

```
OUTPUT 718;"SRCFINTK?;"
```

```
ENTER 718;Tuning
```

SRCPOFS[_]<real>DB|_(UP|DN|EP|OA)|?;

Offsets the displayed power of the 8560E/EC Option 002 tracking generator to compensate for tracking generator test condition gains and losses.

<real> ::= -100 to 100

```
OUTPUT 718;"SRCPWR -10DBM;SRCPSWP 10DB;TS;"
```

```
INPUT "ENTER THE GAIN OF THE PREAMP UNDER TEST",Gain
```

```
OUTPUT 718;"SRCPOFS ";Gain;"DB;"
```

Query response: <numeric data format><LF with EOI>

```
OUTPUT 718;"SRCPOFS?;"
```

```
ENTER 718;Offset
```

SRCSTP[_]<real>DB|_(UP|DN|EP|OA)|?;

Sets the step size of the source power offset, level, and sweep range.

<real> ::= 0.1 to 12.75

UP/DN increment ::= 0.1 dB steps

```
OUTPUT 718;"SRCPWR -10DBM;SRCSTP 1DB;TS;"
```

Query response: <numeric data format><LF with EOI>

```
OUTPUT 718;"SRCSTP?;"
```

```
ENTER 718;Step
```

Programming Commands (alphabetical index)

SRCPSWP[_]<real>DB|_(UP|DN|ON|OFF|EP|OA)|?;

Sweeps the output power of the tracking generator over the chosen power-sweep range.

<real>::= 0 to 12.75

UP/DN increment::= 0.1 dB

OUTPUT ;718;;"SRCPWR -10DBM;SRCPSWP 10DB;TS;"

Query response: <numeric data format><LF with EOI>

OUTPUT 718;"SRCPSWP?;"

ENTER 718;PswEEP

SRCPWR[_]<real><amplitude units>|_(ON|OFF|UP|DN|EP|OA)|?;

Activates the output power of the 8560E/EC Option 002 Tracking Generator.

<real>::= -10 to 2.8

OUTPUT 718;"SRCPWR ON;TS;DONE?;"

ENTER 718;Done

Query response: (1|0)<LF with EOI>

OUTPUT 718;"SRCPWR?;"

ENTER 718;Srcpower

SRCTKPK;

Activates a routine that adjusts both the coarse- and fine-tracking adjustments to obtain the peak response.

OUTPUT 718;"SRCPWR ON;"

OUTPUT 718;"SWPCPL SR;"

OUTPUT 718;"SRCTKPK;DONE?;"

ENTER 718;Done

SRQ[_]<integer>;

Sets a service request if the operand bits are allowed by RQS.

<integer>::= 0 through 255

OUTPUT 718;"RQS 4;SRQ 4;"

Programming Commands (alphabetical index)

SS[_]<real><frequency units>|_ (AUTO|MAN|UP|DN|EP|OA)|?;

Specifies the center frequency step size.

Default units are Hz.

UP/DN increment::=1,2,5 sequence

OUTPUT 718;"CF 100MHZ;SS 100MHZ;"

Query response: <numeric data format><LF with EOI>

OUTPUT 718;"TS;MKPK HI;MKSS;SS?;"

ENTER 718;Step_size

ST[_]<real><time units>|_ (UP|DN|EP|OA|AUTO|MAN)|?;

Specifies the sweep time.

Default units are seconds.

UP/DN increment::= 1, 2, 5 sequence

OUTPUT 718;"CF 20MHZ;SP 10MHZ;ST UP UP;"

OUTPUT 718;"ST 5SEC;"

Query response: <numeric data format><LF with EOI>

OUTPUT 718;"SP 100KHZ;ST?;"

ENTER 718;Sweep_time

STB?|_OA;

Status byte query returns to the controller the decimal equivalent of the bits set in the status byte.

Query response: <numeric data format><LF with EOI>

OUTPUT 718;"RQS 20;SRQ 20;"

Repeat: !

OUTPUT 718;"STB?"

ENTER 718;Status

IF Status < > 20 THEN GOTO Repeat

Programming Commands (alphabetical index)

STOREOPEN;

Saves the current instrument state and trace A in memory. Use STOREOPEN with STORESHORT to obtain an averaged open/short calibration trace.

```
OUTPUT 718;"IP;SNGLS;FA 300KHZ;FB 1GHZ;SRCPWR ON;SWPCPL SR;"
PRINT "CONNECT OPEN. PRESS CONTINUE TO STORE OPEN DATA."
PAUSE
OUTPUT 718;"TS;DONE?;"
ENTER 718;Done
OUTPUT 718;"STOREOPEN;"
OUTPUT 718;"TS;DONE?;"
ENTER 718;Done
```

STORESHORT;

Averages the current data in trace A with open data stored using STOREOPEN, then stores it in state register 8. To ensure valid averaged data, the instrument state must be the same when STOREOPEN and STORESHORT are executed.

```
!example continued from STOREOPEN
PRINT "CONNECT SHORT. PRESS CONTINUE TO AVERAGE AND STORE DATA"
PAUSE
OUTPUT 718;"TS;DONE?;"
ENTER 718;Done
OUTPUT 718;"STORESHORT;TS;DONE?;"
ENTER 718;Done
```

STORETHRU;

Stores a thru calibration trace in trace B and in state register 9.

```
OUTPUT 718;"IP;SNGLS;FA 300KHZ;FB 1GHZ;SRCPWR ON;SWPCPL SR;"
PRINT "CONNECT THRU. PRESS CONTINUE TO STORE DATA."
PAUSE
OUTPUT 718;"SRCTKPK;TS;DONE?;"
ENTER 718;Done
OUTPUT 718;"STORETHRU;TS;DONE?;"
ENTER 718;Done
```

Programming Commands (alphabetical index)

SWPCPL_(SR|SA|OA)|?;

Selects a stimulus response (SR) or spectrum analyzer (SA) sweep time equation.

OUTPUT 718;"SRCPWR ON;SWPCPL SR;TS;"

Query response: (SR|SA)<LF with EOI>

OUTPUT 718;"SWPCPL?;"

ENTER 718,Swpcpl\$

SWPOUT_(RAMP|FAV|FAVA)|?;

Selects the output for J8.

RAMP::= sweep ramp 0 to 10 volts

FAV::= frequency analog voltage (0.5 V/GHz)

FAVA::= frequency analog voltage attenuated (0.25 V/GHz) *For 8564E/EC and 8565E/EC only.*

OUTPUT 718;"SWPOUT RAMP;"

Query response: (RAMP|FAV|FAVA)<LF with EOI>

OUTPUT 718;"SWPOUT ?;"

ENTER 718;Sweep\$

—T—

TDF_(A|B|I|M|P|OA)|?;

Formats trace information for return to a controller. IP selects P.

A::= specifies A-block format

B::= specifies binary data format

I::= specifies I-block data format

M::= specifies ASCII data format

P::= specifies real number output format. Numbers are Hz, volts, watts, dBm, dB μ V, dBV, or seconds.

OUTPUT 718;"TS;VIEW TRA;TDF P:TRA?;"

Query response: (A|B|I|M|P)<LF with EOI>

OUTPUT 718;"TDF?;"

ENTER 718;Format\$

Programming Commands (alphabetical index)

TH[_]<real><amplitude units>|_(ON|OFF|UP|DN|EP|OA)|?;
Blanks signal responses below the specified threshold level. Default units are dBm.
UP/DN increment::= Log scale/div or 10 dB in linear scale
OUTPUT 718;"TH -75DBM;"
OUTPUT 718;"TH OFF;"
Query response: <numeric data format><LF with EOI>
OUTPUT 718;"TH?;"
ENTER 718;Threshold

TITLE_<string data field>;
Sets the analyzer to title mode where characters called from the analyzer character set appear near the upper-right hand corner of the display. Up to two 16-character lines can be displayed.
OUTPUT 718;"TITLE%This is a sample";
OUTPUT 718;"title, two lines%";

TM_(FREE|VID|LINE|EXT|OA)|?;
Selects the trigger mode.
OUTPUT 718;"TM LINE;"
OUTPUT 718;"TM FREE;"
Query response: (FREE|VID|LINE|EXT)<LF with EOI>
OUTPUT 718;"TM ?;"
ENTER 718;Trigger\$

TRA?|[_](<number><number>|<block data field>);
Input or output 601 data points to or from trace A. (See TDF.) Places trace A in view mode before trace data transfer.
DIM A(0:600)
OUTPUT 718;"SNGLS;TS;TDF P;TRA?;"
FOR I=0 TO 599
OUTPUT 718;A(I);"DBM,";
NEXT I
OUTPUT 718;A(600);"DBM;"
Query response: (<number>,<LF with EOI>)|<block data field>
DIM B(0:600)
OUTPUT 718;:"TDF P;TRA?;"
ENTER 718;B(*)

Programming Commands (alphabetical index)

TRB?[[_](`<number><number>`),`<block data field>`);
Input or output 601 data points to or from trace B. (See TDF.) Places trace B in view mode before trace data transfer.

```
INTEGER A(0:600)
OUTPUT 718;"SNGLS;TS;TDF B;TRB?;"
OUTPUT 718 USING "#,W";A(*)
```

Query response: (`<number>`),`<LF with EOI>`)|`<block data field>`

```
INTEGER A(0:600)
OUTPUT 718;"TDF B;TRB?;"
ENTER 718 using "#,W";A(*)
OUTPUT 718;"RL?;"
ENTER 718;Ref_lvl
OUTPUT 718;"LG ?;"
ENTER 718;Scale
FOR X=0 TO 600
  A(X)=Ref_lvl+Scale*(A(X)/60-10)
NEXT X
```

TRIGPOL_(NEG|POS)|?;

Selects the edge (positive or negative) of the trigger input that causes the trigger event.

```
OUTPUT 718;"TRIGPOL POS;"
```

Query Response:(NEG|POS)`<LF with EOI>`

```
OUTPUT 718;"TRIGPOL?;"
ENTER 718;Trig_pol$
```

TS;

Takes a sweep.

```
OUTPUT 718;"SNGLS;CF 10MHZ;SP 1MHZ;TS;"
```

TWNDOW_`<trace destination>`,`<window>`;

Creates a window trace array for the FFT function. The window is a weighting function that forces the ends of FFT input data smoothly to zero. This reduces step discontinuity and measurement error.

`<window>`::= FLATTOP|HANNING|UNIFORM

```
OUTPUT 718;"TWNDOW TRA,UNIFORM;TS;"
OUTPUT 718;"FFT TRA,TRB,TRA;"
```

Programming Commands (alphabetical index)

—V—

VAVG[_]<integer>|_(ON|OFF|UP|DN|EP|OA)|?;

Turns the video averaging on or off.

<integer>::=represents the maximum number of sweeps executed for averaging. Default is 100.

UP/DN increment::=1

OUTPUT 718;"VAVG 10;"

Query response: <integer><LF with EOI>

OUTPUT 718;"VAVG?;"

ENTER 718;Vid_avg

VB[_]<real><frequency units>|_(UP|DN|AUTO|MAN|EP|OA)|?;

Specifies the video bandwidth. Default units are Hz.

<real>::= 1 Hz to 3 MHz

UP/DN increment::= 1, 3, 10 sequence

OUTPUT 718;"RB 10KHZ;VB DN;"

OUTPUT 718;"VB 1HZ;"

Query response: <numeric data format><LF with EOI>

OUTPUT 718;"RB 100KHZ;VB UP UP;VB?;"

ENTER 718;Video_bw

VBR[_]<real>|_(UP|DN|EP|OA)|?;

Specifies the ratio between the video bandwidth and the resolution bandwidth. When the resolution bandwidth is changed, the video bandwidth changes to maintain the ratio. For example, an entry of 0.3 sets the video bandwidth one bandwidth step lower than the resolution bandwidth.

<real>::= 0.003 to 3.00

UP/DN increment::= 1, 3, 10 sequence

OUTPUT 718;"VBR 3;RB 10KHZ;"

Query response: <numeric data format><LF with EOI>

OUTPUT 718;"VBR DN DN;VBR?;"

ENTER 718;Video_ratio

Programming Commands (alphabetical index)

VIEW_(TRA|TRB);

Stores and views the specified trace.

OUTPUT 718;"CLRW TRA;TS;VIEW TRA;"

VTL[_]<real><amplitude units>|_(UP|DN|EP|OA)|?;

Sets the level for video trigger.

UP/DN increment::=Log scale/div or 10 dB in linear scale

OUTPUT 718;"TM VID;VTL -55 DBM;"

Query response: <numeric data format><LF with EOI>

OUTPUT 718;"VTL ?;"

ENTER 718;Trig_lvl

Notation Conventions

BOLD TYPE	All characters appearing in bold type are key words and must appear exactly as shown.
CAPITAL LETTERS	All characters that are capital letters are secondary key words and appear within the key word syntax. They must appear exactly as shown; their meanings can be found under “Secondary Key Word Summary.”
< >	Characters in angular brackets are considered elements of the language being defined. Their meanings can be found under “Syntax Conventions,” unless otherwise specified with the key word definition.
[]	Square brackets indicate that whatever occurs within the brackets is optional.
 	“Or” indicates a choice of exactly one element from a list (for example, <a> indicates <a> or but not both).
()	Parentheses are used to clarify which elements to choose from.
_	Underscore indicates a space must be placed at that location (for example, A_<a> indicates there must be a space between the key word, A , and the element, <a>).
::=	“Is defined as.” For example, <a>::=<c> indicates that <a> can be replaced by the series of elements <c> in any statement where <a> occurs.

Syntax Conventions

<A-block data field>::=	#A<length><command list> (use when the length of the command list is known)
<A-block data format>::=	#A<length><command list>
<amplitude units>::=	DB DM DBM DBMV DBUV V W
<block data field>::=	<A-block data field> <I-block data field>
<command list>::=	one or more spectrum analyzer commands
<CR>::=	ASCII 13 (carriage return)
<END>::=	end of data transmission
<frequency units>::=	HZ KZ KHZ MZ MHZ GZ GHZ
<I-block data field>::=	#I<command list>END; (use when the length of the command list is not known)
<integer>::=	positive or negative integer number in the range of -32768 through +32767
<length>::=	two 8-bit bytes specifying the length of the command list
<LF>::=	ASCII 10 (line feed)
<numeric data format>::=	<real><LF><EOI>
<real>::=	positive or negative real number
<string data field>::=	<string delimiter> <text> <string delimiter>
<string delimiter>::=	!"#\$%&' / : = @ \ ~ `
<terminator>::=	(<amplitude unit> <time unit> <frequency unit>)
<time unit>::=	S SC SEC MS MSEC US
<trace destination>::=	TRA TRB
<trace source>::=	TRA TRB
<trace window>::=	TRA TRB

Secondary Key Word Summary

Secondary key words are parameters appearing in capital letters within the argument of key words. Their definitions are included in the following list.

A	ampere (unit); A-block data format; external mixer frequency band
AC	alternating current (coupling)
ALL	all (marker off, plot screen)
AM	amplitude modulation (DEMOD)
ANNT	annotation
AUTO	automatic operation
B	8-bit byte output format
CURR	current (IF adjustment)
D	external mixer frequency band
DC	direct current (coupling)
DB	relative decibel (unit)
DBM	absolute decibel milliwatt (unit)
DBMV	absolute decibel millivolt (unit)
DBUV	absolute decibel microvolt (unit)
DM	absolute decibel milliwatt (unit)
DN	decrement the parameter
DSP	display
E	external mixer frequency band
EDGE	trigger edge
EP	enable parameter for front panel operator entry
EXT	external (reference, mixer mode)
F	external mixer frequency band
FAV	frequency analog voltage (0.5 V/GHz)
FAVA	frequency analog voltage attenuated (0.25 V/GHz)
FLATTOP	FFT window format
FM	frequency modulation (DEMOD)
FREE	free run
FULL	full band span width
G	external mixer frequency band
GHZ	gigahertz (unit)
GRT	graticule
GZ	gigahertz (unit)

Secondary Key Word Summary

HANNING	FFT window format
HARM	harmonic number (frequency diagnostic)
HI	highest
HZ	hertz
I	I-block data format
INT	internal (reference, mixer mode)
J	external mixer frequency band
K	external mixer frequency band
KHZ	kilohertz (unit)
KZ	kilohertz (unit)
LAST	previous state before a change
LAST SPAN	previous span before a change
LEVEL	trigger level
LINE	line, as in line trigger
LO	local oscillator (frequency diagnostic)
M	ASCII display data output format
MA	milliamp (unit)
MAN	manual operation
MHZ	megahertz (unit)
MS	millisecond (unit)
MSEC	millisecond (unit)
MROLL	fractional N frequency (frequency diagnostic)
MV	millivolt (unit)
MW	milliwatt (unit)
MZ	megahertz (unit)
NEG	negative peak detection or negative polarity
NH	next highest
NL	next left
NR	next right
NRM	normal rosenfell detection
OA	function query (same as "?")
OFF	turn function off
ON	turn function on
P	real number output format
POS	positive peak detection or positive polarity
POSTSC	postscaler (fractional N divide value)
PRE	preselected external mixer mode

Secondary Key Word Summary

PWRON	sets same state as turning power on
Q	external mixer frequency band
RAMP	sweep ramp voltage (LO SWP)
RAWOSC	raw oscillator (fractional N) frequency
S	second (unit)
SA	spectrum analyzer (sweep time coupling)
SC	second (unit)
SEC	second (unit)
SMP	sample detection, sampling oscillator (frequency diagnostic)
SR	stimulus response (sweep time coupling)
TRA	trace A
TRB	trace B
U	external mixer frequency band
UA	microamp (unit)
UNIFORM	FFT window format
UNPR	unpreselected external mixer mode
UP	increment the parameter
UV	microvolt (unit)
US	microsecond (unit)
V	volt (unit); external mixer frequency band
VID	video
W	watt (unit); external mixer frequency band
Y	external mixer frequency band
ZERO	zero span
0	off
1	on
?	returns a query response containing the value or state of the associated parameter (same as OA)

Error Messages

Error messages can appear during spectrum analyzer operation. Next to each message is a description of the error.

Error messages are combined into several general categories:

- Series 100 errors indicate incorrect spectrum analyzer programming via GPIB. These error messages are described in Table 6-1.
- Series 200 and 300 errors indicate hardware or firmware failure.
- Series 400 and 500 errors indicate IF alignment failure. The automatic alignment routine adjusts amplitude parameters first, then resolution bandwidths in this sequence: 300 kHz, 1 MHz, 2 MHz, 100 kHz, 30 kHz, 10 kHz, 3 kHz, 1 kHz, 300 Hz, 100 Hz, 30 Hz, 10 Hz, 3 Hz, and 1 Hz. The routine restarts from the beginning if a fault is detected. Errors labeled “AMPL” imply amplitude accuracy failure.

Errors labeled “RBW” imply resolution bandwidth and amplitude accuracy problems. Parameters adjusted after the routine begins and before the fault is detected should be acceptable; parameters adjusted later in the sequence are suspect. Thus, bandwidth values in the error message indicate that the displayed bandwidth or a narrower bandwidth may have poor shape or gain accuracy.

- Series 600 and 700 errors indicate failure in hardware and firmware interaction or indicate checksum error.
- Series 800 errors indicate failure in an option module.
- Series 900 errors indicate incorrect data entry or user operation that resulted in measurement error. These errors are described in Table 6-2.

For a complete listing of all error messages, refer to *Agilent Technologies 8560 E-Series and EC-Series Spectrum Analyzers User's Guide*.

The spectrum analyzer displays error messages in the lower-left corner of the display and shows one error message at a time. To check for additional errors, press **RECALL**, **MORE 1 OF 2**, **RECALL ERRORS**. Additional error messages appear in the active function block of the display. Use the step keys to scroll through additional messages. If an error occurs during remote operation, **ERRORS** appears in the softkey menu. Pressing **ERRORS** accesses error messages.

Realigning the LO and IF may eliminate some errors. Press **CAL** and **REALIGN LO & IF** to activate the alignment routines.

Table 6-1. Remote Operation Errors

Error Message	Description
ERR 100 NO PWRON	Power-on state is invalid; default state is loaded.
ERR 101 NO STATE	State to be recalled not valid or not saved.
ERR 106 ABORTED!	Current operation is aborted; GPIB parser reset.
ERR 107 HELLO ??	No GPIB listener is present.
ERR 108 TIME OUT	Analyzer timed out when acting as controller.
ERR 109 CtrlFail	Analyzer unable to take control of the bus.
ERR 110 NOT CTRL	Analyzer is not system controller.
ERR 111 # ARGMTS	Command does not have enough arguments.
ERR 112 ??CMD??	Unrecognized command.
ERR 113 FREQ NO!	Command cannot have frequency units.
ERR 114 TIME NO!	Command cannot have time units.
ERR 115 AMPL NO!	Command cannot have amplitude units.
ERR 116 ?UNITS??	Unrecognizable units.
ERR 117 NOP NUM	Command cannot have numeric units.
ERR 118 NOP EP	Enable parameter cannot be used.
ERR 119 NOP UPDN	UP/DN are not valid arguments for this command.
ERR 120 NOP ONOF	ON/OFF are not valid arguments for the command.

6-2 Error Messages

Table 6-1. Remote Operation Errors (continued)

Error Message	Description
ERR 121 NOP ARG	AUTO/MAN are not valid arguments for command.
ERR 122 NOP TRC	Trace registers are not valid for this command.
ERR 123 NOP ABLK	A-block format not valid here.
ERR 124 NOP IBLK	I-block format not valid here.
ERR 125 NOP STRNG	Strings are not valid for this command.
ERR 126 NO ?	This command cannot be queried.
ERR 127 BAD DTMD	Not a valid peak detector mode.
ERR 128 PK WHAT?	Not a valid peak search parameter.
ERR 129 PRE TERM	Premature A-block termination.
ERR 130 BAD TDF	Arguments are only for TDF command.
ERR 131 ?? AM/FM	AM/FM are not valid arguments for this command.
ERR 132 !FAV/RMP	FAV/RAMP are not valid arguments for this command.
ERR 133 !INT/EXT	INT/EXT are not valid arguments for this command.
ERR 134 ??? ZERO	ZERO is not a valid argument for this command.
ERR 135 ??? CURR	CURR is not a valid argument for this command.
ERR 136 ??? FULL	FULL is not a valid argument for this command.
ERR 137 ??? LAST	LAST is not a valid argument for this command.
ERR 138 !GRT/DSP	GRT/DSP are not valid arguments for this command.
ERR 139 PLOTONLY	Argument can only be used with PLOT command.
ERR 140 ?? PWRON	PWRON is not a valid argument for this command.
ERR 141 BAD ARG	Argument can only be used with FDIAG command.
ERR 142 BAD ARG	Query expected for FDIAG command.
ERR 143 NO PRESL	No preselector hardware to use command.
ERR 144 COUPL??	Invalid COUPLING argument, expected AC or DC.

Table 6-2. Data and Other User-Generated Errors

Error Message	Description
ERR 900 TG UNLVL	Tracking generator output is unlevelled. Check the internal/external leveling mode; this error should not appear when internal leveling is used and the source power is less than the specified maximum leveled power.
ERR 901 TGFrqLmt	Tracking generator output is unlevelled because the start frequency is set below the tracking generator frequency limit of 300 kHz.
ERR 902 BAD NORM	The state of the stored trace does not match the current state of the analyzer; thus, the normalization is not meaningful.
ERR 903 A > DLMT	Part or all of unnormalized trace A is off screen with trace math or normalization on; thus, part or all of the result is inaccurate.
ERR 904 B > DLMT	Part or all of the calibration trace (trace B) is off screen with trace math or normalization on; thus part or all of the result is inaccurate.
ERR 905 EXT REF	Unable to lock Cal Oscillator when set to external reference. Check that the external reference is within tolerance.
ERR 906 OVENCOLD	The OCXO oven is cold; wait until it warms up.
ERR 907 DO IF CALS	Instrument is still performing IF calibration or is in need of an IF calibration. The calibration may not have been done due to an OVENCOLD condition.

6-4 Error Messages

Table 6-2. Data and Other User-Generated Errors (continued)

Error Message	Description
ERR 908 BW>>SPCG	Channel bandwidth is too wide, compared to the channel spacing, for a meaningful computation.
ERR 909 SPAN<ACP	The frequency span is too small to obtain a valid ACP measurement.
ERR 910 SPAN>ACP	The frequency span is too wide, compared to the channel bandwidth, to obtain a valid ACP measurement.
ERR 911 ACP STATE	The adjacent channel power measurement has been compromised (invalid measurement parameters).
ERR 919 SP<CHBW	The channel spacing is too narrow, compared to the channel bandwidth, to obtain a valid channel power bandwidth measurement.
ERR 920 RBW>CHBW	The resolution bandwidth is too wide, compared to the channel bandwidth, to obtain a valid channel power bandwidth measurement. The resolution bandwidth should be much less than the channel bandwidth ($<0.1 \times$ channel BW).
ERR 921 ↑AMPCOR↓	Measurement data which would normally be displayed above the top graticule, and therefore has unspecified accuracy, has been corrected by the amplitude correction function (ampcor) to appear between the top and bottom graticule.
ERR 922 ↓AMPCOR↓	Measurement data which would normally be displayed below the bottom graticule, and therefore has unspecified accuracy, has been corrected by the amplitude correction function (ampcor) to appear between the top and bottom graticule.

— |

| —

— |

| —

A

Block Diagrams

Block Diagrams A-1

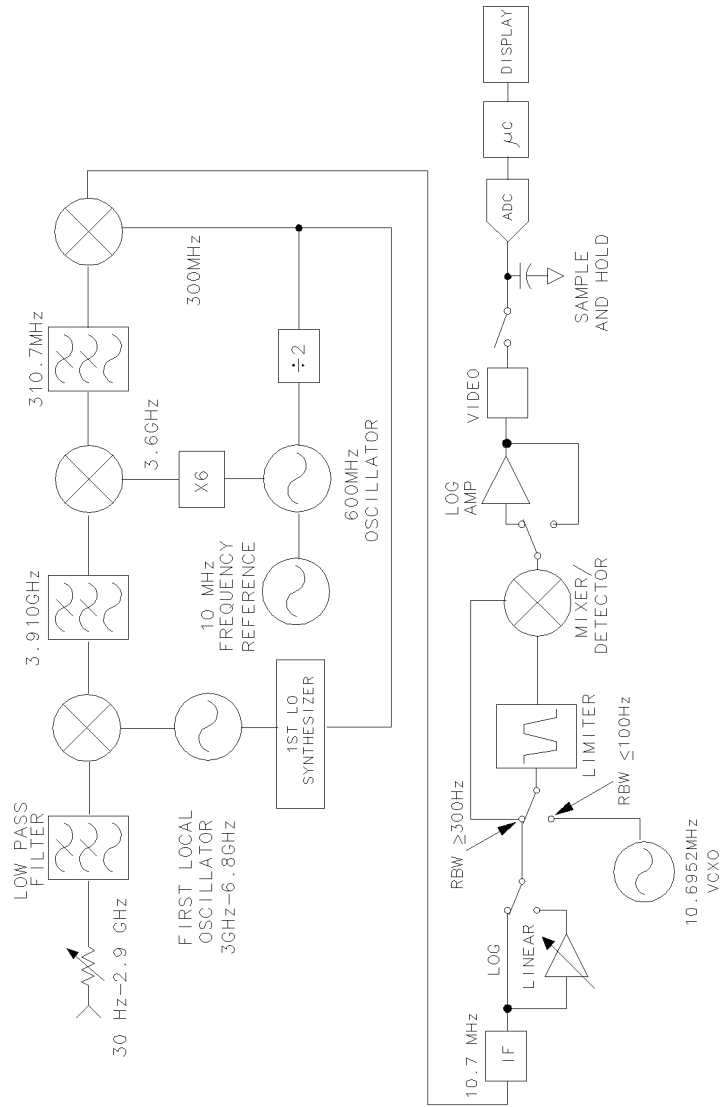

8560E/EC Block Diagram

qj130e

A-2 Block Diagrams

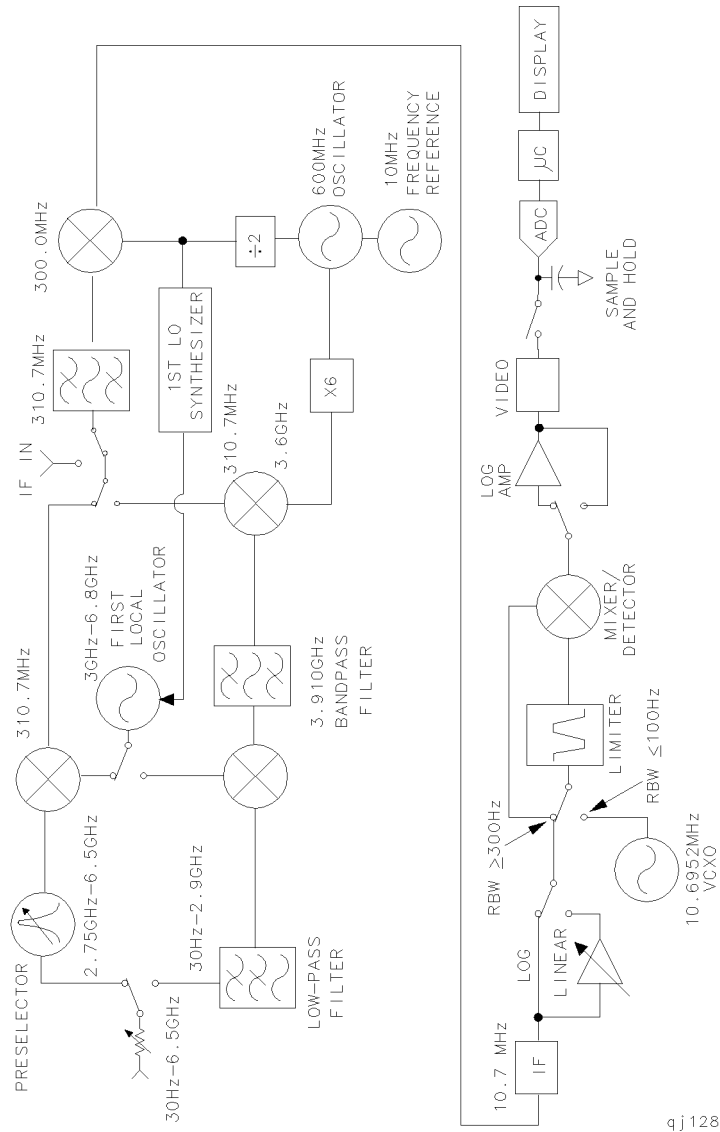

8561E/EC Block Diagram

qj128e

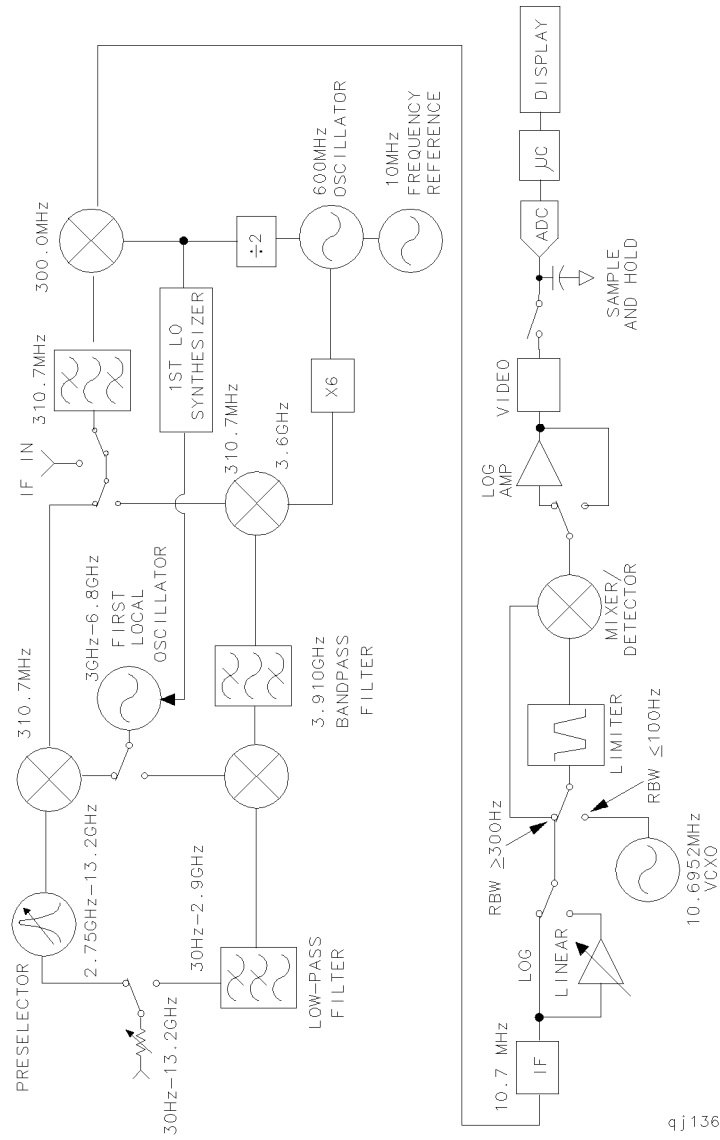

8562E/EC Block Diagram

qj136e

A-4 Block Diagrams

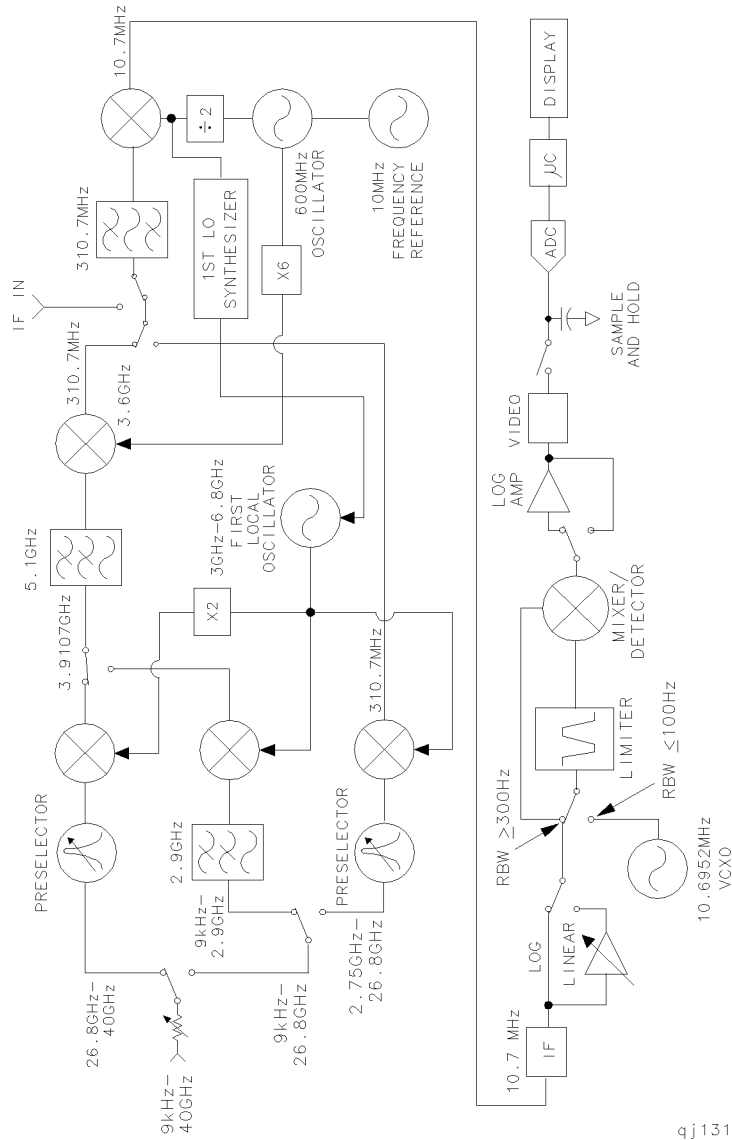

8564E/EC Block Diagram

qj131e

A-6 Block Diagrams

— |

| —

— |

| —