

# HP 85027A/B/C DIRECTIONAL BRIDGE

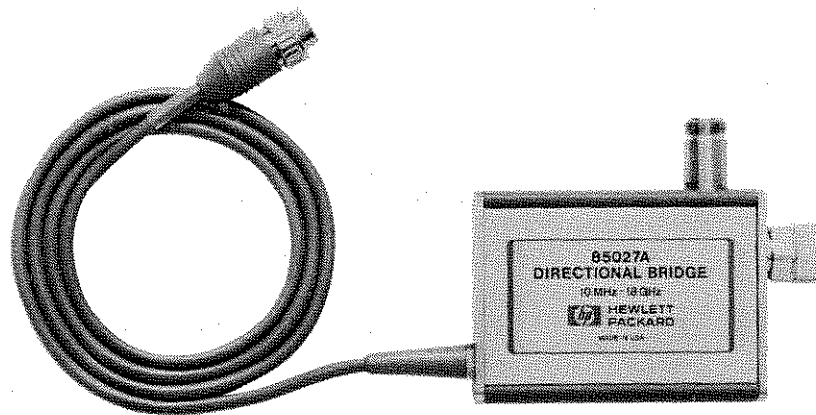

**HEWLETT  
PACKARD**



# MANUAL CHANGES

## NOTE

Manual change supplements are revised as often as necessary to keep manuals as current and accurate as possible. Hewlett-Packard recommends that you periodically request the latest edition of this supplement. Free copies are available from all HP offices. When requesting copies, quote the manual identification information from your supplement, or the model number and print date from the title page of the manual.

## MANUAL IDENTIFICATION

**HP Number:** HP 85027A/B/C

**Date Printed:** July 1985

**Part Number:** 85027-90001

This supplement contains important information for correcting manual errors and for adapting the manual to instruments containing improvements made after the printing of the manual.

Two types of information are included:

**UPDATES - APPLY TO ALL SERIAL NUMBERS.**

**NUMBERED CHANGES - UPDATES THAT ARE SERIAL NUMBER PREFIX RELATED.**

The information is in the following order: UPDATES, NUMBERED CHANGES in sequential order with applicable illustrations as close as possible to each numbered change.

To use this supplement, make all UPDATES and all appropriate serial number related CHANGES indicated in the following pages.

▶ = NEW ITEM

## UPDATES

### ▶ Title Page:

Write (or paste) the following note on the title page:

Notice, this manual no longer supports the HP 85027A. Refer to the HP 85027A operating and service manual, HP Part Number 85027-90021.

Replace the following manual pages with the pages in this document (UPDATES):

#### General Information

1-6

#### Performance Tests

4-8

#### Adjustments

5-3

5-4

NOVEMBER 1, 1987



Printed in U.S.A.



Table 1-1. Specifications

	HP 85027A	HP 85027B	HP 85027C
<b>Frequency Range (GHz)<sup>1</sup></b>	0.01-18.0	0.01-26.5	0.01-18.0
<b>Connector: Input Test Port</b>	Type N (f) APC-7	3.5mm (f) 3.5mm (f)	Type N (f) Type N (f)
<b>Max. Input Power</b>	+23 dBm or ±10 volts	+23 dBm or ±10 volts	+23 dBm or ±10 volts
<b>Directivity<sup>2</sup></b>			
0.01 to 12.4 GHz	>=40 dB	>=40 dB	>=36 dB
12.4 to 18.0 GHz	>=40 dB	>=40 dB	>=34 dB
18.0 to 20.0 GHz	—	>=40 dB	—
20.0 to 26.5 GHz	—	>=36 dB	—
<b>Test Port Match<sup>2</sup></b>			
0.01 to 8.4 GHz	>=23 dB	>=23 dB	>=23 dB
8.4 to 12.4 GHz	>=19 dB	>=15 dB	>=19 dB
12.4 to 18.0 GHz	>=15 dB	>=15 dB	>=15 dB
18.0 to 20.0 GHz	—	>=15 dB	—
20.0 to 26.5 GHz	—	>=11 dB	—

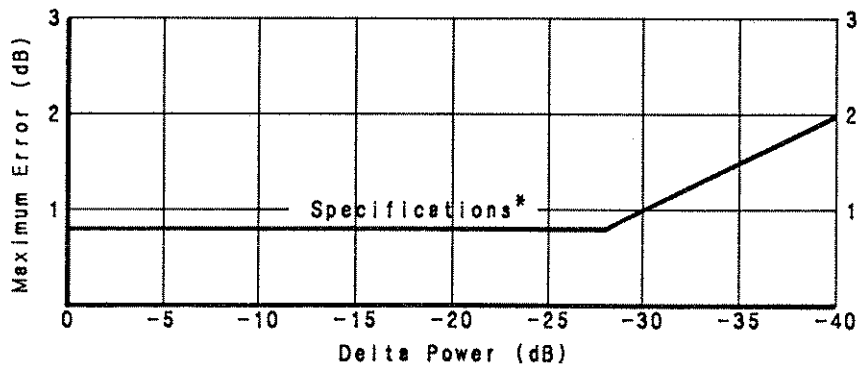

\*Measured at 50 MHz  
 \*Relative to +7dBm input to bridge  
 \*25°C±5°C

Dynamic Power Accuracy



**Equipment**

	HP 85027A	HP 85027B	HP 85027C
Sweep Oscillator	HP 8350B	HP 8350B	HP 8350B
RF plug-in	HP 83592A	HP 83595A	HP 83592A
Scalar network analyzer	HP 8757A	HP 8757A	HP 8757A
Cal. open/short	85021-60021	85037-60001	85032-60001
50 ohm load	909A opt 012	909D	909A opt 012
Adapter*	not req'd	85027-60002	1250-1475

\* A second directional bridge is required as a test instrument in addition to the directional bridge under test. The adapters recommended are suitable for use with two similar bridges.

**Procedure**

1. Set up the equipment as shown in Figure 4-4, with the calibrated open connected to the test directional bridge, not the directional bridge under test.
2. PRESET the analyzer. It should indicate that Input A is on Channel 1. Turn off Channel 2. The Preset should also preset the sweep oscillator to a sweep time of 200 ms with 27.8 kHz modulation on.
3. Set the sweep oscillator start and stop frequencies to correspond to the first band of frequencies in the Performance Test Record (0.01 to 8.4 GHz).
4. Perform an open/short calibration and store it in memory.
5. Connect the directional bridge under test to the first directional bridge, test port to test port with an adapter if necessary. Connect the 50 ohm load to the input port of the directional bridge under test.
6. On the HP 8757A turn on the cursor and press the [MAX] softkey to find the point of minimum return loss (highest point) on the trace. Enter this value on the Performance Test Record.
7. Repeat steps 3 through 7 for each frequency band of interest.
8. If the test results (including uncertainties) are not within specifications as indicated on the Test Port Match Performance Test Record, refer to the Troubleshooting section of this manual.

Table 4-2. Test Port Match Performance Test Record

Frequency Band (GHz)	HP 85027A		HP 85027B		HP 85027C	
	Spec.	Test Result	Spec.	Test Result	Spec.	Test Result
0.01-8.4	>=23 dB	_____	>=23 dB	_____	>=23 dB	_____
8.4-12.4	>=19 dB	_____	>=15 dB	_____	>=19 dB	_____
12.4-18.0	>=15 dB	_____	>=15 dB	_____	>=15 dB	_____
18.0-20.0	—	_____	>=15 dB	_____	—	_____
20.0-26.5	—	_____	>=11 dB	_____	—	_____
Uncertainty*	>=1 dB	_____	>=1 dB	_____	>=2 dB	_____





5. Remove the printed, plastic switch configuration label from the back of the bridge (additional labels are available as HP P/N 85027-80004).
6. Disconnect the power sensor from the attenuator. Turn on modulation. Connect the bridge input port to the attenuator, leaving the test port open.
7. On the analyzer, turn on averaging (avg. factor =8), and the cursor. On the HP 8757A, turn on smoothing (5%).
8. Adjust R5 (see Figure 5-2) for a cursor reading of  $-6 \pm 0.1$  dBm.
9. Set the attenuator to 30 dB. Adjust R29 (Figure 5-2) for a cursor reading of **calibrated**  $-30$  dB minus  $6 \pm 0.1$  dBm.
10. Set the attenuator to 0 dB and adjust R29 (if required) until the cursor reads  $-6 \pm 0.1$  dBm.
11. Repeat steps 8 through 10 until the change in level is equal to the **calibrated** 30 dB  $\pm 0.1$  dB and, with 0 dB attenuation, the cursor indicates  $-6 \pm 0.1$  dBm.

#### DC Adjustment Procedure

**NOTE:** You can perform this DC procedure only with an HP 8757A analyzer.

12. On the HP 8757A, set DC mode.
13. Set the reference level to -50 dBm at midscreen, and the scale to 5 dB/div.
14. On the source, turn off the RF power.
15. On the analyzer, press **[CAL] [CONFIG SYSTEM]**. If your analyzer has firmware revision 2.0 or above, press **[CAL]** and select **[MORE] [AUTOCAL]**, to turn auto calibration OFF.
16. On the bridge, use a short jumper to short pad **Y** (where yellow wire terminates) to ground.
17. Adjust R25 (Figure 5-2) for a minimum reading on the analyzer (it should be  $< -50$  dBm).
18. Remove the short, and turn auto cal back ON.

#### Feedthru Null Adjustment Procedure

19. On the analyzer, press **[CAL]** and select **[DC DET ZERO] [AUTOZERO]**.
20. Adjust R10 (Figure 5-2) for as **HIGH** a trace as possible. Adjust slowly, because averaging and smoothing mask adjustment effects.

**NOTE:** Steps 19 and 20 must be repeated until no further change is noted.



**DC Mode RF Adjustment Check**

21. On the source, turn on the RF power.
22. Set the attenuator to 0 dB.
23. On the analyzer, verify DC mode, averaging, smoothing, and the cursor are still on. Allow the trace to settle. Press **[DISPLAY] [MEAS→MEM] [MEAS-MEM]**. The cursor should now indicate 0.0 dB.
24. Set the attenuator to 30 dB.
25. The cursor should now indicate the calibrated -30 dB to within 0.8 dB.
26. If the value indicated is not within 0.8 dB of the calibrated -30 dB, it may be necessary to adjust R5 and R29 until the **difference** between the 0 dB and 30 dB attenuator settings is **just** within 0.8 dB of the calibrated 30 dB. Adjust R5 when the attenuator setting is 0 dB and R29 when at 30 dB.
27. If any adjustments are made, it will be necessary to repeat the AC Adjustment Procedure again, only this time using a tolerance limit of  $\pm 0.8$  dB instead of the 0.1 dB indicated in steps 8 through 11. This will allow you to split the error difference between the two modes of operation.
28. Both AC and DC dynamic accuracy specifications should be within the limits stated in Table 1-1.

C

C

C

# ADDENDUM MANUAL CHANGES

---

This addendum contains information received too late to be included in the manual shipped with your product. Use the information below to update your manual.

## Manual Identification

This addendum applies to the following document:

**Model Number:** 85027A/B/C

**Date Printed:** July 1985

**Part Number:** 85027-90001

## Instructions

Make the following changes in your manual:

### Page 6-4, Table 6-3A:

- Change MP6 to 2190-0572
- Change MP7 to 0360-0124
- Change MP8 to 0515-1445
- Change MP12 to 85027-80033
- Change MP14 to 5180-8446
- Delete MP17.
- Change MP18 to 85027-80034.
- Change MP19 to 85027-80035.
- Change MP20 to 85027-80036.

### Page 6-6, Table 6-3B:

- Change MP12 to 85027-80026
- Change MP14 to 5180-8446
- Change MP16 to 85027-80037
- Delete MP17.
- Change MP18 to 85027-80034.
- Change MP19 to 85027-80035.

Addendum Date: 18 October 1991





# HP 85027A/B/C DIRECTIONAL BRIDGE

## SERIAL NUMBERS

This manual applies directly to the HP 85027A/B/C directional bridge with serial numbers prefixed as follows:

Model	Serial Prefix
HP 85027A	2522A
HP 85027B	2522A
HP 85027C	2522A

For additional information about serial numbers, refer to INSTRUMENTS COVERED BY MANUAL in Section 1 and BACKDATING, Section 7.

© Copyright      HEWLETT-PACKARD COMPANY      1985  
1400 FOUNTAINGROVE PARKWAY, SANTA ROSA, CA 95401 U.S.A.

MANUAL PART NUMBER 85027-90001  
Microfiche Part Number 85027-90002

Printed: JULY 1985



**HEWLETT  
PACKARD**





CONTENTS

Section	Page
1 GENERAL INFORMATION	1-1
Introduction	1-1
Specifications	1-1
Safety Considerations	1-1
Instruments Covered by Manual	1-1
Description	1-3
Equipment Required But Not Supplied	1-3
Scalar Network Analyzer	1-3
HP 8757A	1-3
HP 8756A	1-3
HP 8755C	1-4
Swept Signal Source	1-4
HP 8350B	1-4
HP 8340A	1-4
HP 8341A	1-4
Detectors	1-4
Power Splitters	1-4
Equipment Available	1-4
Accessories Available	1-4
Recommended Test Equipment	1-5
Warranty Restrictions	1-5
2 INSTALLATION	2-1
Introduction	2-1
Initial Inspection	2-1
Preparation for Use	2-2
Power Requirements	2-2
Connecting the HP 85027	2-2
Mating Connectors	2-2
Operating Environment	2-3
Storage and Shipment	2-3
Environment	2-3
Packaging	2-3
3 OPERATION	3-1
Introduction	3-1
Operating Precautions	3-1
Connector Wear	3-1
Operating Instructions	3-1
Operator's Check	3-4
Equipment	3-4
Procedure	3-4

4	PERFORMANCE TESTS	4-1
	Introduction	4-1
	Performance Test Record	4-1
	Directivity	4-1
	Description	4-1
	Equipment	4-2
	Procedure	4-2
	Below 2 GHz	4-3
	Above 2 GHz	4-4
	Test Port Match	4-7
	Specifications	4-7
	Description	4-7
	Equipment	4-8
	Procedure	4-8
	Dynamic Power Accuracy (AC and DC)	4-9
	Specifications	4-9
	Description	4-9
	Equipment	4-9
	Procedure	4-10
5	ADJUSTMENTS	5-1
	Introduction	5-1
	Adjustment Procedures	5-1
	AC Adjustment Procedure	5-2
	DC Adjustment Procedure	5-3
	Feedthru Null Adjustment Procedure	5-3
	DC Mode RF Adjustment Check	5-4
6	REPLACEABLE PARTS	6-1
	Introduction	6-1
	Exchange Assemblies	6-1
	Replaceable Parts List	6-1
	Organization	6-1
	Information	6-1
	Ordering Information	6-2
7	MANUAL BACKDATING CHANGES	7-1
	Introduction	7-1
	Application	7-1
8	SERVICE	8-1
	Introduction	8-1
	Theory of Operation	8-1
	Troubleshooting Procedures	8-2
	Gaining Internal Access	8-2
	Cable Continuity Check	8-2
	Power Cable Replacement	8-3
	Input Port and Test Port Resistance Checks	8-3
	Microcircuit Check	8-3
	A2 Circuit Board Assembly Replacement	8-4
	A1 Bridge Microcircuit Assembly Replacement	8-4
	Power Supply Check	8-5
	Signal Path Check	8-7
	Clock/Control Check	8-7
	Connector Inspection	8-7
	Visual Inspection	8-7
	Mechanical Inspection	8-9
	Gaging the Precision 3.5mm Connector	8-9
	Gaging the APC-7 Connector	8-14

FIGURES

Figure	Title	Page
1-1	HP 85027A Directional Bridge in Accessory Case Supplied	1-0
1-2	HP 85027A, 85027B and 85027C Directional Bridges	1-2
3-1	HP 85027B with Connector Saver	3-2
3-2	HP 85027 Features (Rear View)	3-3
3-3	Typical Operator's Check Using HP 8757A	3-4
3-4	Typical Measurement Setup Using HP 8757A	3-6
3-5	Typical Measurement Setup Using Power Splitter	3-6
4-1	Directivity Performance Test Setup	4-2
4-2	Probable Range of Directivity Values	4-3
4-3	Signal Separation Chart	4-5
4-4	Test Port Match Performance Test Setup	4-7
4-5	Dynamic Power Accuracy Performance Test Setup	4-9
5-1	Adjustment Setup	5-1
5-2	Locations of Adjustment Potentiometers	5-2
6-1A	HP 85027A Replaceable Parts Identification	6-5
6-1B	HP 85027B Replaceable Parts Identification	6-7
6-1C	HP 85027C Replaceable Parts Identification	6-9
6-2	A2 Circuit Board Component Location (Component Side)	6-11
6-3	A2 Circuit Board Component Location (Solder Side)	6-11
8-1	A2 Circuit Board Power Supply Check Points	8-5
8-2	A2 Circuit Board Schematic	8-6
8-3	Cleaning APC-7 Connectors	8-8
8-4	SMA and Precision 3.5mm Connectors	8-10
8-5	Precision 3.5mm Male Connector Gauge	8-11
8-6	Zeroing Precision 3.5mm Male Connector Gauge	8-12
8-7	Measuring Precision 3.5mm Male Connectors	8-13
8-8	The APC-7 Connector Gauge	8-15
8-9	Zeroing the APC-7 Gauge	8-16
8-10	Gaging APC-7 Connectors	8-17
8-11	Collet Removal and Replacement, APC-7 Connectors	8-18

TABLES

Table	Title	Page
1-1	Specifications	1-6
1-2	Supplemental Characteristics	1-8
1-3	System Verification Kits	1-9
1-4	Accessories Available (Adapters and General)	1-9
1-5	Recommended Test Equipment	1-10
2-1	Contents of HP 85027 Directional Bridges	2-1
4-1	Directivity Performance Test Record	4-6
4-2	Test Port Match Performance Test Record	4-8
4-3	Dynamic Power Accuracy Performance Test Record	4-10
6-1	Exchange Microcircuit Bridge Assemblies	6-2
6-2	Manufacturers Code List, Reference Designators and Abbreviations	6-2
6-3A	HP 85027A Replaceable Parts	6-4
6-3B	HP 85027B Replaceable Parts	6-6
6-3C	HP 85027C Replaceable Parts	6-8
6-4	A2 Circuit Board Assembly Replaceable Parts	6-10
7-1	Manual Backdating Changes By Serial Number Prefix	7-1
8-1	Conductors in Power Cable W1	8-3



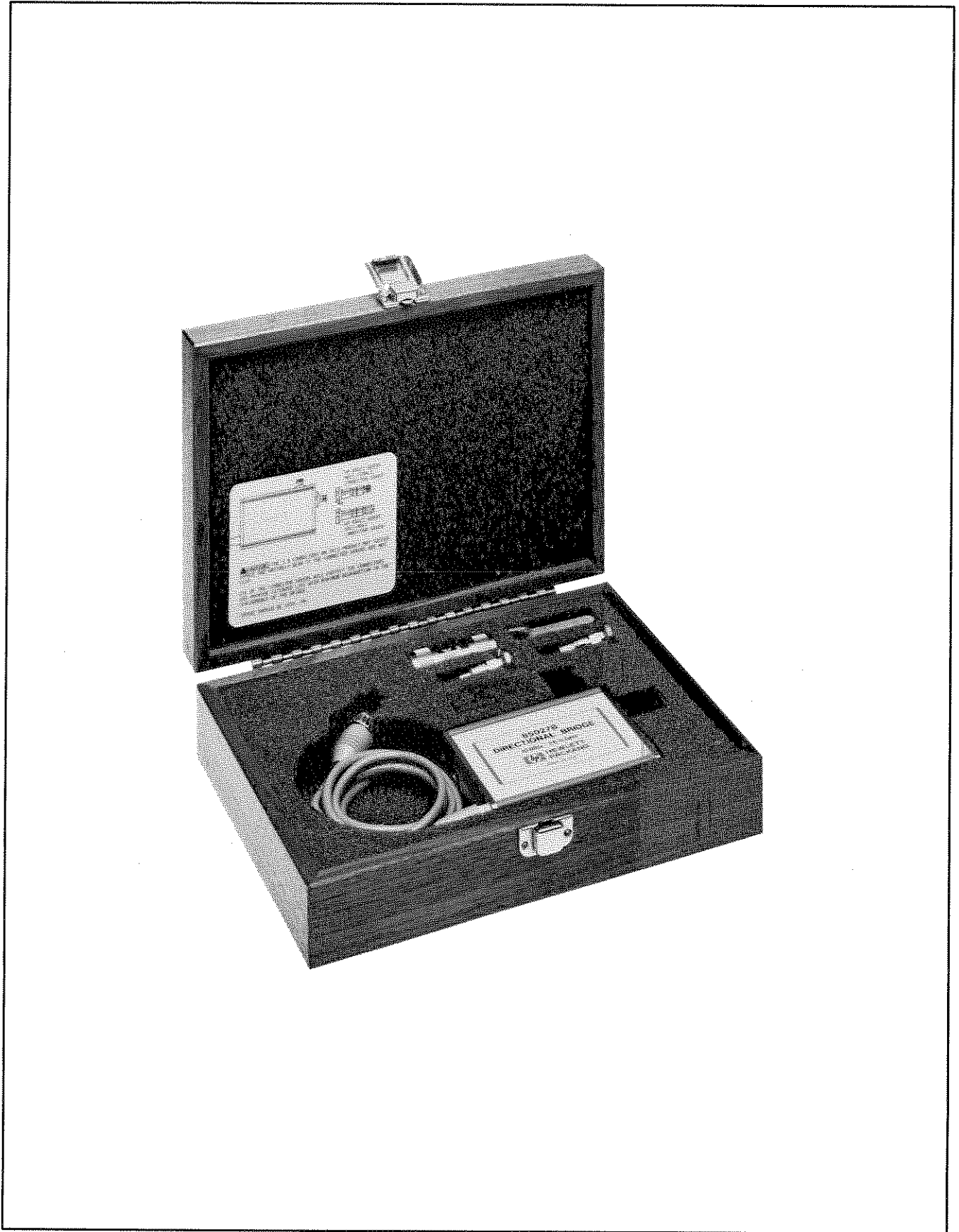

*Figure 1-1. HP 85027B in Accessory Case Supplied*

## SECTION 1

### GENERAL INFORMATION

#### INTRODUCTION

You will find operating and service information for the Hewlett-Packard 85027A, 85027B and 85027C directional bridges in this manual. When the three different bridges share a common trait or procedure, they will be referred to as the HP 85027. The HP 85027B in its case is illustrated in Figure 1-1. Figure 1-2 shows all three directional bridges. The rest of this section describes specifications, supplemental performance characteristics, safety considerations, instrument identification, description, and other basic information.

You may order this manual in microfiche form as part number 85027-90002. With the manual (in 4 x 6 inch microfilm transparency format) you will also receive the latest manual changes supplement and all pertinent service notes in print form.

#### SPECIFICATIONS

Table 1-1 lists the specifications for the HP 85027 directional bridges. The specifications are performance standards or limits against which the bridges may be tested. Table 1-2 lists supplemental characteristics, non-warranted but typical performance parameters, useful in test applications.

#### SAFETY CONSIDERATIONS

The voltages in these directional bridges do not warrant more than normal caution for operator safety.

#### CAUTION

**The CAUTION sign in this manual identifies an operating procedure or practice which, if not correctly performed, could damage or destroy the equipment. Do not proceed beyond a CAUTION sign until you fully understand and meet the conditions indicated.**

#### INSTRUMENTS COVERED BY MANUAL

You will find a two-part serial number on the bridge. The first four digits and the letter are the serial number prefix. The last five digits are the sequential suffix which is unique to each bridge. The contents of this manual apply directly to bridges with the same serial number prefix as the one on the title page under the heading SERIAL NUMBERS.

If the serial prefix of your bridge is not listed on the title page, your instrument is different from those documented in this manual. The differences are documented in the yellow manual changes supplement supplied with the manual.

HP 85027A/B/C General Information

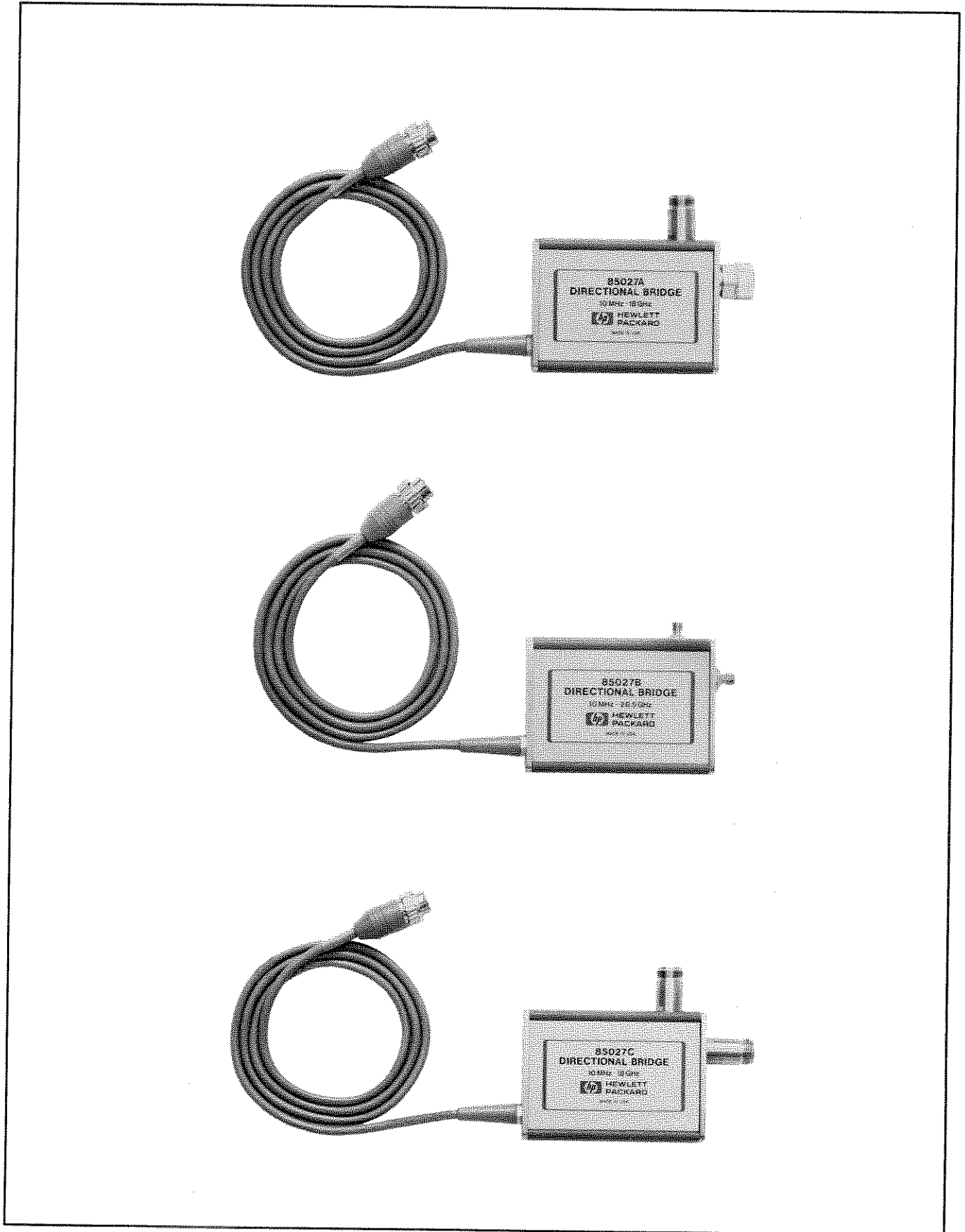

Figure 1-2. HP 85027A, 85027B and 85027C Directional Bridges



To keep this manual as current and accurate as possible, Hewlett-Packard recommends that you periodically request the latest manual changes supplement as it may contain error correction information as well as change information. The supplement for this manual is keyed to the manual's print date and part number (on the title page) and is available free from Hewlett-Packard.

## DESCRIPTION

The HP 85027 bridges are microwave directional bridges designed for making modulated (AC) or unmodulated (DC) scalar reflection measurements with the HP 8757A scalar network analyzer and AC measurements with the HP 8765A and HP 8755C. A single zero-biased Schottky diode detector in the bridge performs reflection measurements by sampling the return loss of the device under test. A detector can be added for simultaneous transmission measurements. A power splitter can be used with the bridge or detector or both for ratio measurements. In all modes, typically the RF input signal is supplied by a sweep oscillator or a synthesized sweeper.

The frequency range and connector type of each bridge appears below and in Table 1-1.

	HP 85027A	HP 85027B	HP 85027C
Frequency range (GHz)	0.01 to 18.0	0.01-26.5	0.01-18.0
Input Connector	Type N (f)	3.5mm (f)	Type N (f)
Test Port Connector	APC-7*	3.5mm (f)	Type N (f)

\*APC-7 is a registered trademark of the Bunker-Ramo Corporation.

## EQUIPMENT REQUIRED BUT NOT SUPPLIED

The following equipment is required for use with the HP 85027 in making reflection, transmission and ratio measurements:

### Scalar Network Analyzer

The frequency range of the three following analyzers is determined by the HP 85027 directional bridge in use.

**HP 8757A:** this scalar network analyzer is a microprocessor based four-channel, three input (four with Option 001) receiver with integral digital display. At RF and microwave frequencies, it makes scalar transmission and reflection measurements over a dynamic range of +16 dBm to -60 dBm and amplitude ratio measurements up to 152 dB. The HP 8757A is completely programmable through HP-IB (Hewlett-Packard Interface Bus, HP's hardware, software, documentation and support for IEEE-488 and IEC 625). Additionally the HP 8757A can control a plotter, a printer, such as the Thinkjet printer, and a swept source through the 8757 System Interface.

The HP 8757A offers both AC and DC detection techniques. The AC technique involves modulating the source signal at 27.8 kHz. Note that in this manual the modulation frequency of 27.8 kHz is actually 27.778 kHz. The DC detection technique modulates the input signal at 27.8 kHz within the bridge, after the DUT.

**HP 8756A:** this scalar network analyzer is also a microprocessor based receiver with its own digital display. With its dual channels, it makes scalar transmission and reflection measurements at RF and microwave frequencies over a dynamic range of -50 dBm to +10 dBm. It can measure amplitude ratios up to 60 dB. It is completely

programmable through HP-IB and can control a plotter and swept source through the 8756 System Interface.

The HP 8756A is only capable of AC mode measurements with the HP 85027 directional bridges.

**HP 8755C:** although this scalar network analyzer is not programmable, it also measures amplitude levels of -50 dBm to +10 dBm and amplitude ratios of 60 dB. Like the HP 8756A, the 8755C is capable of AC mode measurements only.

The HP 8755C plugs into a HP 180 series display mainframe such as the HP 182T or 180TR. If your application requires memory or normalization, use this analyzer with the HP 8750A Storage Normalizer. Refer to Section 1 of the HP 8755C Operation and Service manual for additional information on HP 8750A/8755C compatibility.

### Swept Signal Source

**HP 8350B:** This sweep oscillator mainframe, for one, is a good source for the HP 85027 bridges mated to the HP 8757A because it is solid-state, fully HP-IB programmable and can be controlled by the HP 8757A through the 8757 System Interface. It has internal 27.8 kHz square wave modulation capability and, depending on the RF plug-in selected, can cover the entire frequency range of 0.01 to 26.5 GHz.

**HP 8340A:** this synthesized sweeper is also fully HP-IB programmable and can be controlled by the HP 8757A. It does not require a plug-in as it is a complete analog sweep synthesizer. It generates synthesized output frequencies from 0.01 to 26.5 GHz. The HP 8340A can be square wave modulated at 27.8 kHz by the HP 8757A.

**HP 8341A:** this synthesized sweeper differs from the HP 8340A (above) in frequency range: 0.01 to 20.0 GHz.

### Detectors

One or more HP 85025A/B detectors are used with the HP 85027 directional bridges and the HP 8757A to make transmission measurements in AC or DC mode. The HP 85025A has a frequency range of 10 MHz to 18 GHz and uses a type-N connector (Option 001, APC-7 connector). The HP 85025B has a frequency range of 10 MHz to 26.5 GHz and uses a precision 3.5mm connector. Detection in the AC and DC mode is similar to that of the HP 85027. For AC mode transmission measurements, the HP 11664A/E detector may be used.

### Power Splitter

Ratio measurements can be made with the addition of a power splitter. The HP 11667A has a frequency range of DC to 18 GHz; the HP 11667B, DC to 26.5 GHz.

### EQUIPMENT AVAILABLE

Additional equipment available for use with the HP 85027 directional bridges and the HP 8757A scalar network analyzer is listed in Section 1 of the analyzer's Operating and Service Manual.

### ACCESSORIES AVAILABLE

System verification kits, precision adapters and other miscellaneous accessories available are listed in Table 1-4. Note that the system verification kits are designed so that the

phase response of the short is exactly opposite that of the shielded open and thus provides the best possible calibration data.

### **RECOMMENDED TEST EQUIPMENT**

Table 1-5 lists equipment recommended for use in performance testing the HP 85027 bridges. Other equipment may be substituted if its specifications meet or exceed the specifications listed in the Critical Specifications column.

### **WARRANTY RESTRICTIONS**

Performing any disassembly or repair procedure not included in Section 8, Service, of this manual will void the warranty.

Subjecting a HP 85027 bridge to RF input power levels in excess of +23 dBm or  $\pm 10$  volts will likewise void the warranty.

Connector damage caused by mating with out of spec connectors or improper technique is not covered by the warranty. (See "Connector Inspection" in Section 8, Service.)

Table 1-1. Specifications

	HP 85027A	HP 85027B	HP 85027C
Frequency Range (GHz) <sup>1</sup>	0.01-18.0	0.01-26.0	0.01-18.0
Connector: Input Test port	Type N (f) APC-7	3.5mm (f) 3.5mm (f)	Type N (f) Type N (f)
Max. Input Power	+23 dB or +10 volts	+23 dB or +10 volts	+23 dB or +10 volts
Directivity <sup>2</sup>			
0.01 to 12.4 GHz	>=40 dB	>=40 dB	>=36 dB
12.4 to 18.0 GHz	>=40 dB	>=40 dB	>=34 dB
18.0 to 20.0 GHz	-----	>=40 dB	-----
20.0 to 26.5 GHz	-----	>=36 dB	-----
Test Port Match <sup>2</sup>			
0.01 to 8.4 GHz	>=23 dB	>=23 dB	>=23 dB
8.4 to 12.4 GHz	>=19 dB	>=15 dB	>=19 dB
12.4 to 18.0 GHz	>=17 dB	>=15 dB	>=17 dB
18.0 to 20.0 GHz	-----	>=15 dB	-----
20.0 to 26.5 GHz	-----	>=11 dB	-----

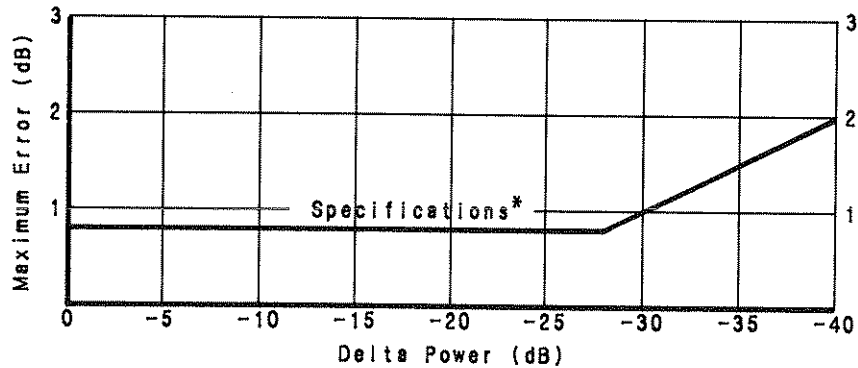

\*Measured at 50 MHz  
 \*Relative to +7dBm input to bridge  
 \*25°C±5°C

Dynamic Power Accuracy

## HP 85027A/B/C General Information

**Dimensions** 26 mm high x 124 mm wide x 118 mm deep  
(1.0" x 4.9" x 4.4")  
cable length 1219 mm (48")

**Weight** net: 0.5 kg (1.2 lb)  
shipping: 2.3 kg (5 lb)

<sup>1</sup> Unless otherwise noted, all specifications apply from 0°C to +55°C.  
<sup>2</sup> +25°C ±5°C.

Table 1-2. Supplemental Characteristics

Values in this table are not specifications but are typical, non-warranted performance parameters included for user information.

**Typical Directivity with Connector Savers (Adapters)  
(To 3.5mm male or female)**

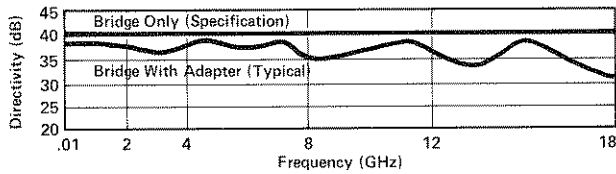

**HP 85027A**

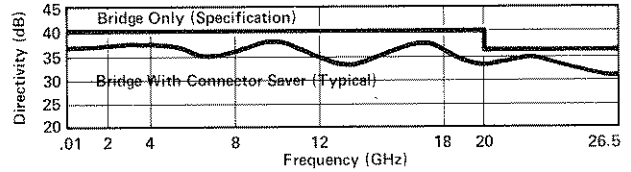

**HP 85027B**

	<b>HP 85027A</b>	<b>HP 85027B</b>	<b>HP 85027C</b>
<b>Typical Insertion Loss</b>			
at 0.01 GHz	6.5 dB	6.5 dB	6.5 dB
at 18.0 GHz	8.0 dB	8.0 dB	8.0 dB
at 26.5 GHz	-----	10.0 dB	-----
<b>Typical Input Port Match</b>			
0.01 to 8.4 GHz	$\geq 20$ dB	$\geq 20$ dB	$\geq 20$ dB
8.4 to 18.0 GHz	$\geq 15$ dB	$\geq 15$ dB	$\geq 15$ dB
18.0 to 26.5 GHz	-----	$\geq 10$ dB	-----
<b>Typical Min. Input Power for a 40 dB Return Loss at 18 GHz</b>			
HP 8757A	+2 dBm	+2 dBm	+2 dBm
HP 8756A/55C	+7 dBm	+7 dBm	+7 dBm
<b>Typical Impedance</b>	50 ohms	50 ohms	50 ohms

HP 85027A/B/C General Information

Table 1-3. System Verification Kits

HP 85023A (APC-7) for use with HP 85027A		
Qty	Accessory	HP Part or Model No.
1	APC-7 open/short	85021-60001
1	N (m) to N (m) adapter	1250-1475
1	APC-7 50 ohm termination	909A
1	APC-7 10 dB pad	8492A opt 010
1	instrument case	9211-1582
1	operating note	85023-90001

HP 85023B (3.5mm) for use with HP 85027B		
Qty	Accessory	HP Part or Model No.
1	3.5mm open/short	85037-60001
1	3.5mm (m) to N (m) adapter	1250-1743
1	3.5mm 50 ohm termination	909D
1	3.5mm 10 dB pad	8493C opt 010
1	instrument case	9211-1582
1	operating note	85023-90003

HP 85023C (Type-N) for use with HP 85027C		
Qty	Accessory	HP Part or Model No.
1	Type-N short	11512A
1	Type-N open	85032-60001
1	N (m) to N (m) adapter	1250-1475
1	Type-N 50 ohm termination	909A opt 012
1	Type-N 10 dB pad	8491B opt 010
1	instrument case	9211-1582
1	operating note	85023-90005

Table 1-4. Accessories Available

ADAPTERS/CONNECTOR SAVERS				
Connector	3.5mm m	3.5mm f	N m	N f
APC-7	1250-1746	1250-1747	11525A	11524A
3.5mm m	85027-60002	85027-60003	1250-1743	1250-1750
3.5mm f		1250-1749	1250-1744	1250-1745
N m			1250-1475	--
N f				1250-1472

GENERAL	
APC-7 contact extractor	5060-0236
APC-7 connector service kit	11591A
wrench, thin open end 1/2" x 9/16"	8710-0877
anti-static wrist strap	9300-0791

HP 85027A/B/C General Information

Table 1- 5. Recommended Test Equipment

Instrument	Critical Specifications	85027A	85027B	85027C
Scalar Network Analyzer	85027 AC/DC compatible	8757A	8757A	8757A
Sweep Oscillator with RF Plug-in	8757A compatible Frequency: 0.01 to 18 GHz Frequency: 0.01 to 26.5 GHz	8350B with 83592A/B or 83595A	8350B with 83595A	8350B with 83592A/B or 83595A
or Synthesized Sweeper	Frequency: 0.01 to 20 GHz Frequency: 0.01 to 26.5 GHz	8341A	8340A	8341A
Detectors (2)	Frequency: 0.01 to 18 GHz Frequency: 0.01 to 26.5 GHz	85025A	85025B	85025A
Power Splitter	Frequency: 0.01 to 18 GHz Frequency: 0.01 to 26.5 GHz	11667A	11667B	11667A
Power Meter	Frequency: 0.01 to 26.5 GHz	436A	436A	436A
Power Sensor	Frequency: 0.01 to 18 GHz Connector: Type-N (f)	8481B		8481B
	Frequency: 0.05 to 26.5 GHz Connector: 3.5mm		8485A	
10 dB Step Attenuator	Frequency: dc to 4 GHz Connector: Type-N (f)	8495A opt 001		8495A opt 001
	Frequency: dc to 26.5 GHz Connector: 3.5mm		8495D opt 004	
50 ohm Fixed Load	APC-7 3.5mm Type-N	909C	909D/040	909C/012
50 ohm Sliding Load	APC-7/Type-N, 1.8 to 18 GHz 3.5mm, 2 to 26.5 GHz	905A	911C	905A
Digital Multimeter	Accuracy: $\pm 0.01\%$ Input Impedance: $\geq 10M\Omega$	3456A	3456A	3456A
This equipment is used for performance testing, adjustment and troubleshooting.				



**SECTION 2**  
**INSTALLATION**

**INTRODUCTION**

This section provides information about initial inspection, preparation for use, mating connectors, packaging, storage and shipment.

**INITIAL INSPECTION**

Inspect the shipping container (including cushioning material) for damage. If damaged, keep it until you have (1) checked the contents for completeness, (2) read the three following cautions and (3) checked the bridge mechanically and electrically. The contents are listed in Table 2-1.

*Table 2-1. Contents of HP 85027 Directional Bridges*

	HP 85027A	HP 85027B	HP 85027C
Instrument Case	yes	yes	yes
Operating and Service Manual	yes	yes	yes
Adapter/Connector saver	Type-N m/Type-N m	3.5mm m/3.5mm m 3.5mm m/3.5mm f	Type-N m/Type-N m
Open/short	7mm open/short	3.5mm open/short	Type-N open Type-N short
Wrench	no	yes	no

Read and observe these cautions: save yourself time and trouble.

**CAUTION**

Use caution when mating an SMA male connector to the precision 3.5mm female connectors on the HP 85027B. Push the connectors straight together, with the male contact concentric with the female. **DO NOT** overtighten or rotate either center conductor; turn only the outer nut of the male. An out of spec connector can permanently damage its mate. For this reason, you should measure connectors with a connector gage (see Section 8, "Mechanical Inspection") and use connector savers whenever possible (see Figure 3-1).

**CAUTION**

Do not apply more than +23 dBm RF power or more than ±10 volts DC to the HP 85027. More power or voltage will damage the bridge.

## CAUTION

Electrostatic discharge (ESD) can damage the highly sensitive microcircuits in the HP 85027 bridges. ESD damage is most likely to occur as the bridges are connected or disconnected. Protect the bridges by wearing a grounding strap that provides a path to ground of no less than 1 Megohm and no more than 2.5 Megohms. Alternatively, ground yourself by touching the outer shell of any grounded instrument chassis before touching the bridge connectors.

Never touch the center contacts of the connectors.

Use a work station equipped with an anti-static surface.

Electrical performance checks are in Section 4 of this manual. If the bridge does not pass the electrical performance tests, refer to the Troubleshooting Procedures in Section 8. If the bridge does not pass the electrical tests, or if it is damaged or defective, or if the contents are incomplete, keep the shipping materials and notify both the carrier and the nearest Hewlett-Packard office. The HP office will arrange for repair or replacement of the bridge without waiting for settlement of the claim.

## PREPARATION FOR USE

### Power Requirements

Power for the HP 85027 is supplied by the network analyzer.

### Connecting the HP 85027

Insert the connector of the bridge's power cable (W1) into the A, B, (C if HP 8757A, Option 001) or R mating connector of the analyzer and turn the outer sleeve clockwise to tighten it.

Connect the HP 85027's input port to the RF output port of the source.

Connect the device under test to the bridge's test port. Section 3 shows typical measurement configurations. Refer to Section 8 for information on the care and use of APC-7 and precision 3.5mm connectors.

### Mating Connectors

APC-7 connectors mate with APC-7 connectors. Precision Type-N connectors mate with the corresponding precision Type-N connectors whose dimensions conform to US specification MIL-C-39012. 3.5mm connectors mate to the corresponding 3.5mm connectors.

To extend the life of the 3.5mm female connectors, use the precision 3.5mm (m) to 3.5mm (m) adapter or the 3.5mm (m) to 3.5mm (f) adapter. They are included with the HP 85027B as noted in Table 2-1 and illustrated in Figure 3-1.

### Operating Environment

The instrument may be operated in temperatures from 0°C to +55°C but should be protected from environmental conditions which cause internal condensation. It may be operated at altitudes up to 4 572 metres (15 000 feet).

## STORAGE AND SHIPMENT

### Environment

The HP 85027 may be shipped or stored in temperatures from  $-40^{\circ}\text{C}$  to  $+75^{\circ}\text{C}$  and at altitudes up to 15 240 metres (50 000 feet). It should be protected from environmental conditions which may cause internal moisture condensation.

### Packaging

Ideally each bridge should be repackaged in the original factory package if reshipping is required. Containers and materials identical to those used by the factory are available through Hewlett-Packard offices. Alternatively, comparable packaging materials may be used. In any case, please observe the following guidelines:

- a. Wrap the bridge in heavy paper or anti-static plastic. If shipping to a HP Office or Service Center complete and attach a service tag (HP P/N 9320-3896, see Section 6 of this manual or another system component manual).
- b. Use sufficient shock absorbing material on all sides of the HP 85027 to provide a thick, firm cushion and prevent internal movement.
- c. Seal the shipping container securely and mark it **FRAGILE**.

In any correspondence, refer to the component by full model and serial number.



## SECTION 3

### OPERATION

#### INTRODUCTION

This section contains information concerning operation of the HP 85027 directional bridges.

#### OPERATING PRECAUTIONS

You can dramatically degrade the performance of the HP 85027 bridges through ESD damage, excessive input or excessive mechanical shock. Therefore read and heed the cautions below:

##### CAUTION

**Do not subject the bridge to ESD. Work static-free.**

**Do not input more than +23dBm RF power or more than  $\pm 10$  volts DC.**

**Do not drop the HP 85027 or subject it to mechanical shock.**

#### CONNECTOR WEAR

The input port and test port connectors are part of the microcircuit bridge assembly. They are not separately replaceable or field repairable although the entire assembly can be replaced with a new or rebuilt assembly. An exception to the preceding sentence is described in Section 8. Information about exchange assemblies is in Section 6.

Repeated connections will cause the connectors to become worn with a consequent degradation of performance. This is a subtle but relentless form of degradation. It is best countered by using an adapter, or connector saver, on the test port whenever some loss in directivity can be tolerated. Refer to Table 1-2 to see the minimal performance loss incurred by using HP's high quality adapters and connector savers.

For measuring SMA devices from 10 MHz to 18 GHz, HP recommends using the HP 85027A with an APC-7 to 3.5mm adapter. For measuring SMA devices to 26.5 GHz, HP recommends using the HP 85027B with one of the connector savers (male/male or male/female) which are supplied with the bridge (see Figure 3-1).

Only high quality adapters achieve accurate, repeatable measurements and even they must be replaced periodically for best performance. When calibrating, use the same adapters and interconnect cables that will be used for measurements. Additional information on the proper care and inspection of connectors, adapters and connector savers is in Section 8.

#### OPERATING INSTRUCTIONS

Because the HP 85027 has been designed specifically to operate with the HP 8757A scalar network analyzer, operating instructions have been included in Section 3 of the analyzer's Operating manual. Figure 3-2 of this manual illustrates the features of the bridges. Figure 3-2 shows a typical measurement setup with the HP 8757A. When you use the bridge with the HP 8757A, set the configuration switch on the bridge to the

## HP 85027A/B/C Operation

[HP8757] position. If you are using the HP 8756A or 8755C with the HP 85027, set the bridge configuration switch to [HP8756/HP8755] and refer to that analyzer's manual for the corresponding setups. Figure 3-5 shows a typical measurement setup using a power splitter.

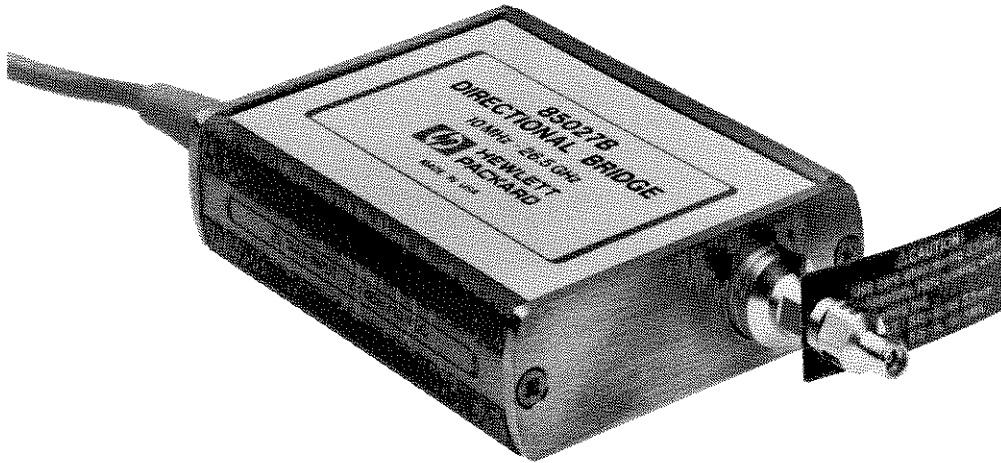

*Figure 3-1. HP 85027B with Connector Saver*

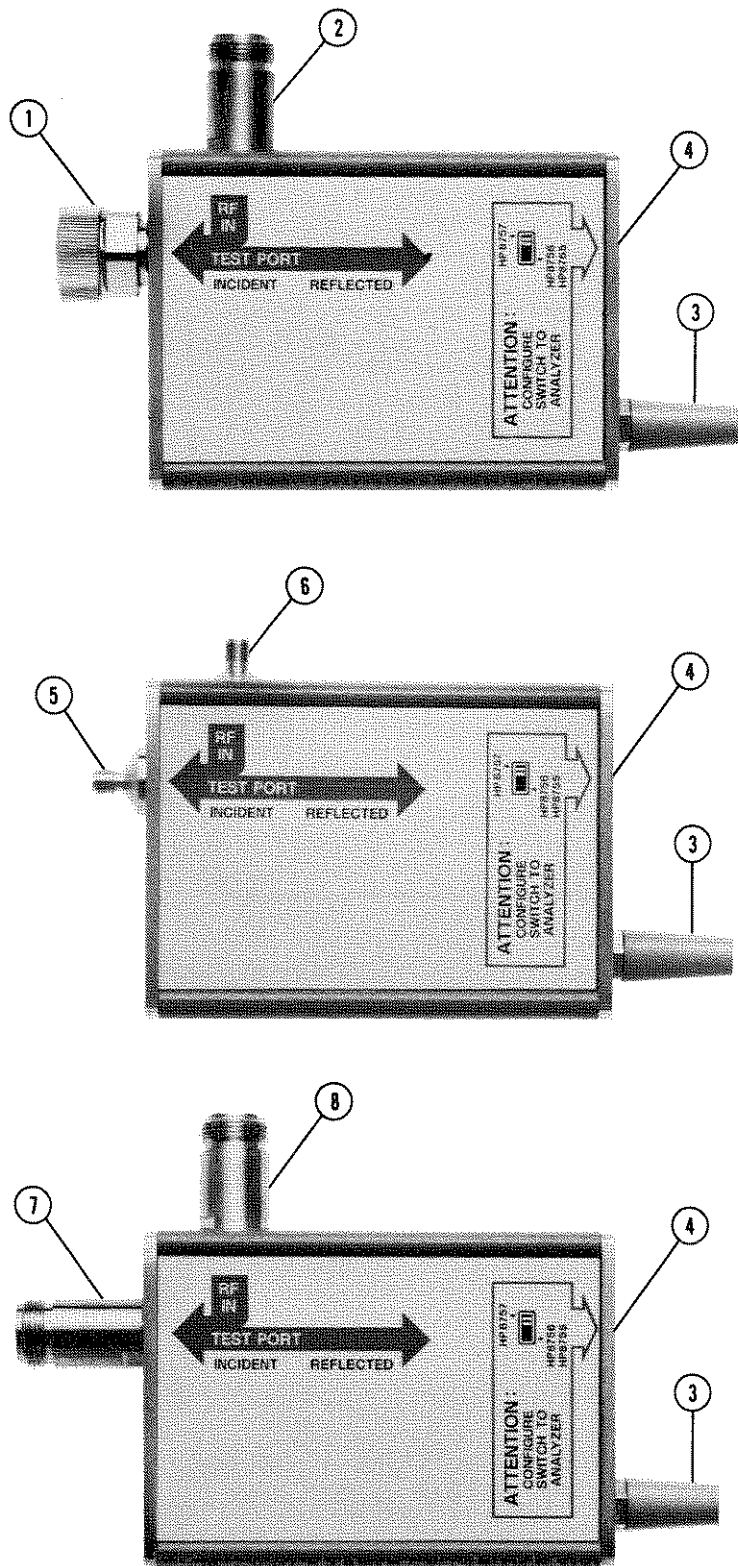

1. Test port connector J2 (APC-7). Connect the device under test (DUT), calibration short or open here.

2. Input port connector J1 (Type-N). Apply the RF input signal here.

3. Power supply cable W1. This cable supplies DC voltages to the bridge, performs control functions and feeds to the analyzer data on the signal reflected by the DUT.

4. Configuration switch S1. This switch sets the bridge for use with either the HP 8757A or HP 8756A/8755C.

5. Test port connector J2 (3.5 mm). Connect the DUT, calibration short or open here.

6. Input connector J1 (3.5 mm). Apply the RF signal here.

7. Test port connector J2 (Type-N). Connect the DUT, calibration short or open here.

8. Input connector J1 (Type-N). Apply the RF signal here.

Figure 3-2. HP 85027 Features (Rear View)

**OPERATOR'S CHECK**

Figure 3-3 illustrates the setup for the operator's check procedure. Follow this procedure to quickly check the entire measurement system. Incorrect results may be caused by any portion of the system, but if the HP 85027 is suspected use the performance tests in Section 4 to determine whether the bridge is operating correctly. If the bridge fails those tests, turn to Section 8 to isolate the problem.

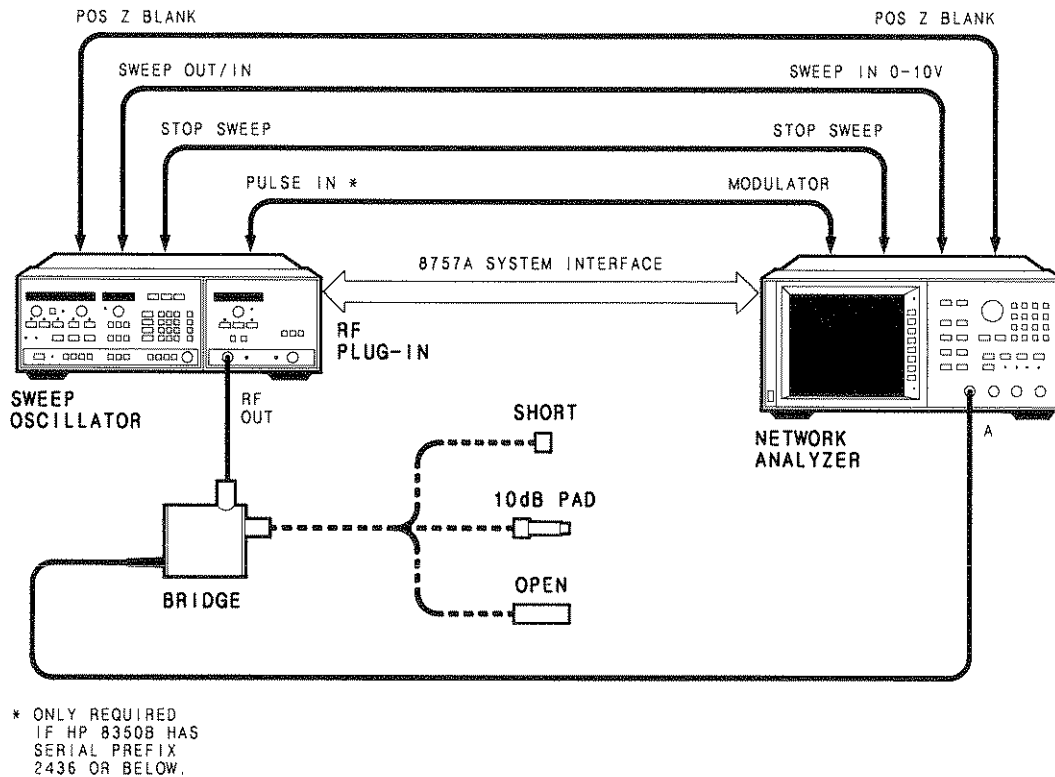

Figure 3-3. Typical Operator's Check using HP 8757A

**Equipment**

Bridge	HP 85027A	HP 85027B	HP 85027C
Analyzer*	HP 8757A	HP 8757A	HP 8757A
Sweep oscillator	HP 8350B	HP 8350B	HP 8350B
RF plug-in	HP 83592A	HP 83595A	HP 83592A
Calibrated open	85021-60001	85037-60001	85032-60001
Calibrated short	85021-60001	85037-60001	11512A
10 dB pad	8492A Opt 010	8493C Opt 010	8491B Opt 010

\*Note: If you perform this procedure with the HP 8756A or 8755C, (1) set the configuration switch in step 2 to [HP8756/HP8755] and (2) do not perform step 9.

**Procedure**

1. Connect the equipment as shown in Figure 3-3 and turn it on.
2. Set the HP 85027 switch (S1) to [HP8757].



## HP 85027A/B/C Operation

3. PRESET the HP 8757A and turn off channel 2.
4. Set the HP 8350B to output 50 MHz swept CW.
5. Perform a short/open calibration and then press [DISPLAY] [MEAS-MEM] on the HP 8757A for normalized measurements. Turn on the cursor.
6. With nothing connected to the test port of the bridge, set the RF plug-in to indicate a CRSR value of 0.0 dB on the CRT.
7. Connect the 10 dB pad to the test port of the bridge.
8. The CRSR value should now be  $-20.0 \pm 2.0$  dB.
9. To check the DC performance of the bridge, perform steps 1 through 4. Then select [MODE DC] and perform a manual DC ZERO. Continue with steps 5 through 9. The final result should again be  $-20.0 \pm 2.0$  dB.

# HP 85027A/B/C Operation

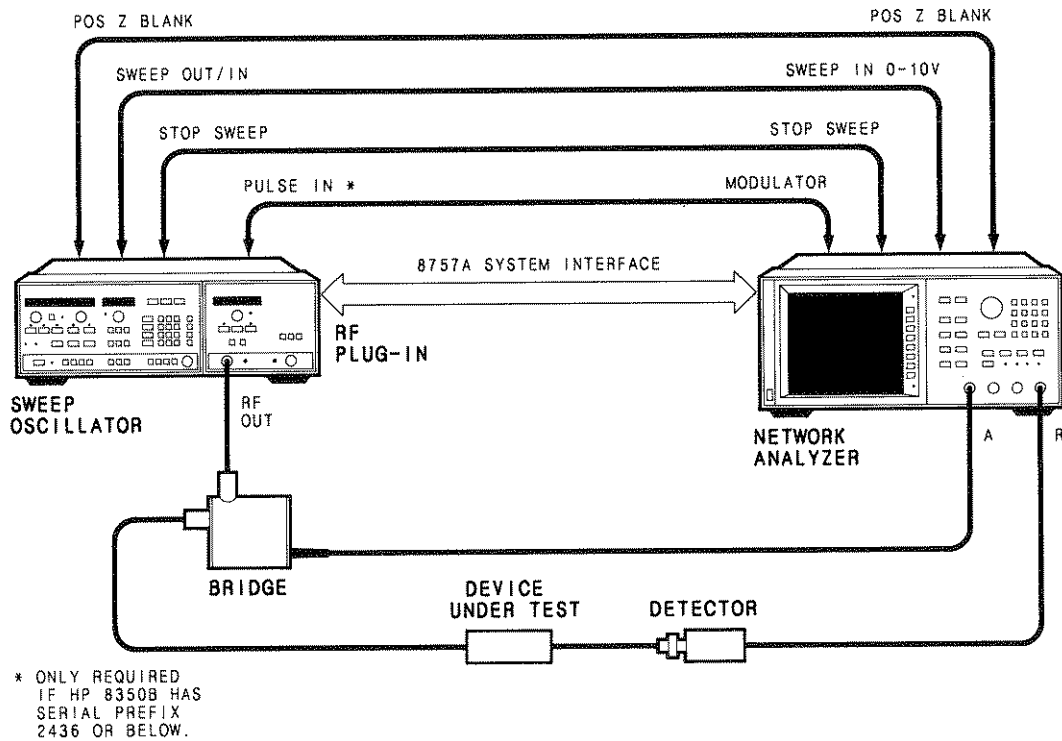

Figure 3-4. Typical Measurement Setup using HP 8757A

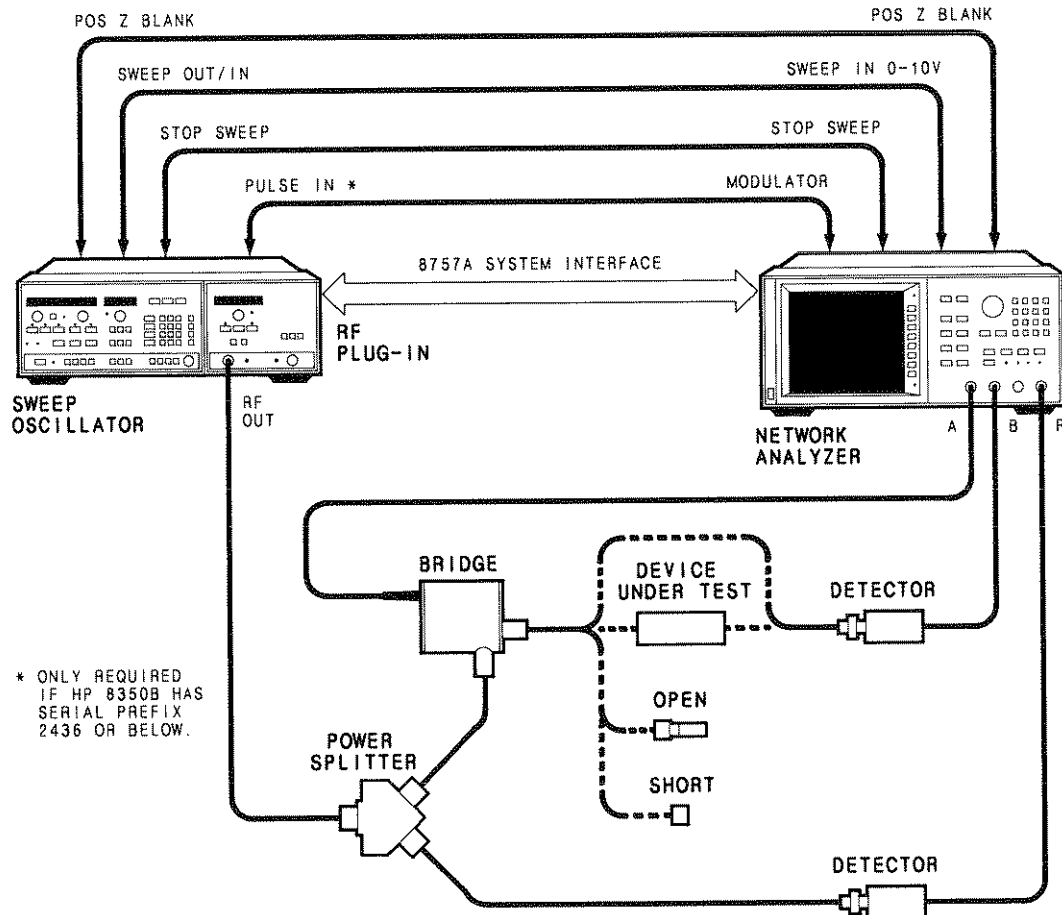

Figure 3-5. Typical Measurement Setup using Power Splitter

## SECTION 4

### PERFORMANCE TESTS

#### INTRODUCTION

The procedures in this section test the directivity, test port match and dynamic accuracy of the HP 85027 directional bridges using the specifications of Table 1-1 as the performance standards. Space to record the specifications and test results are incorporated in Tables 4-1, 4-2 and 4-3. Each test procedure lists the equipment required. You may substitute test equipment if the substitute equipment meets or exceeds the critical specifications of Table 1-5. Each of the tests can be performed without access to the interior of the bridge.

#### PERFORMANCE TEST RECORD

Tabulate the results of the performance tests in Tables 4-1, 4-2 and 4-3. The performance test records provide space to list all of the tested specifications and their acceptable limits. Test results recorded during incoming inspection can be used for comparison with test results obtained after periodic maintenance, troubleshooting, repairs or adjustments.

#### DIRECTIVITY

##### Description

Directivity is a measure of the ability of a directive device (in this case the HP 85027) to discriminate between incident and reflected signals. In principle directivity can be measured when the test port is terminated with a perfect load to absorb (and thereby eliminate) all reflected signals. In this perfect situation, any remaining signals detected would be directivity errors, the result of reflections due to imperfections of the bridge itself.

Perfect loads do not exist. The following test procedures make allowances for the errors caused by the imperfect loads. Note that while there are no perfect loads, loads do vary in quality and that quality directly influences the performance test results. Use the highest quality load available.

# HP 85027A/B/C Performance Tests

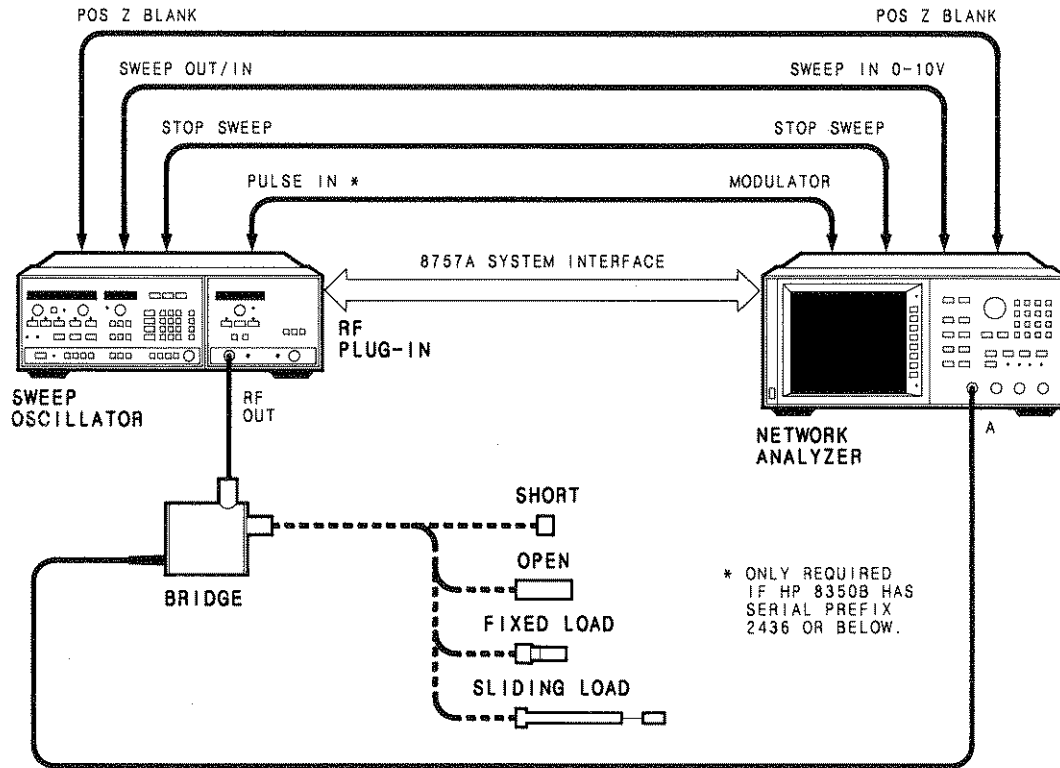

Figure 4-1. Directivity Performance Test Setup

## Equipment

	HP 85027A	HP 85027B	HP 85027C
Analyzer	HP 8757A	HP 8757A	HP 8757A
Sweep oscillator	HP 8350B	HP 8350B	HP 8350B
RF plug-in	HP 83592A	HP 83595A	HP 83592A
Short	85021-60001	85037-60001	11512A
Open	85021-60001	85037-60001	85032-60001
Sliding load	905A	911C	905A
Fixed load	909C	909D opt 040	909C opt 012

## NOTE

This test must be performed between 20 °C and 30 °C to be valid.

## Procedure

1. Connect the equipment as shown in Figure 4-1. Do not connect anything to the bridge test port.
2. On the HP 8757A, press [PRESET] to configure the system. The HP 8757A PRESET will also (1) set the sweep time and turn on the modulation of the sweep oscillator and (2) turn on the RF output and set the power level of the RF plug-in. Do not reset the power level. Press the analyzer's softkey [CHAN 2 OFF] to turn off channel 2.

## HP 85027A/B/C Performance Tests

### Below 2 GHz:

3. On the HP 8350B set the START and STOP frequencies to the frequencies on the first line of Table 4-1, Directivity Performance Test Record.
4. Perform a short/open calibration by pressing [CAL] on the HP 8757A and then following the prompts on the CRT.
5. Attach the fixed load to the test port of the HP 85027. On the analyzer, press [CURSOR] and softkeys [CURSOR ON] and [MAX] to find the point of minimum return loss (the high point on the trace). Record the displayed CURSOR value on the appropriate line of Table 4-1. Note that this value represents the scalar sum of directivity signals (the desired measurement plus signals reflected from the fixed load (undesired error). Thus fixed load quality directly affects the quality of directivity measurements.

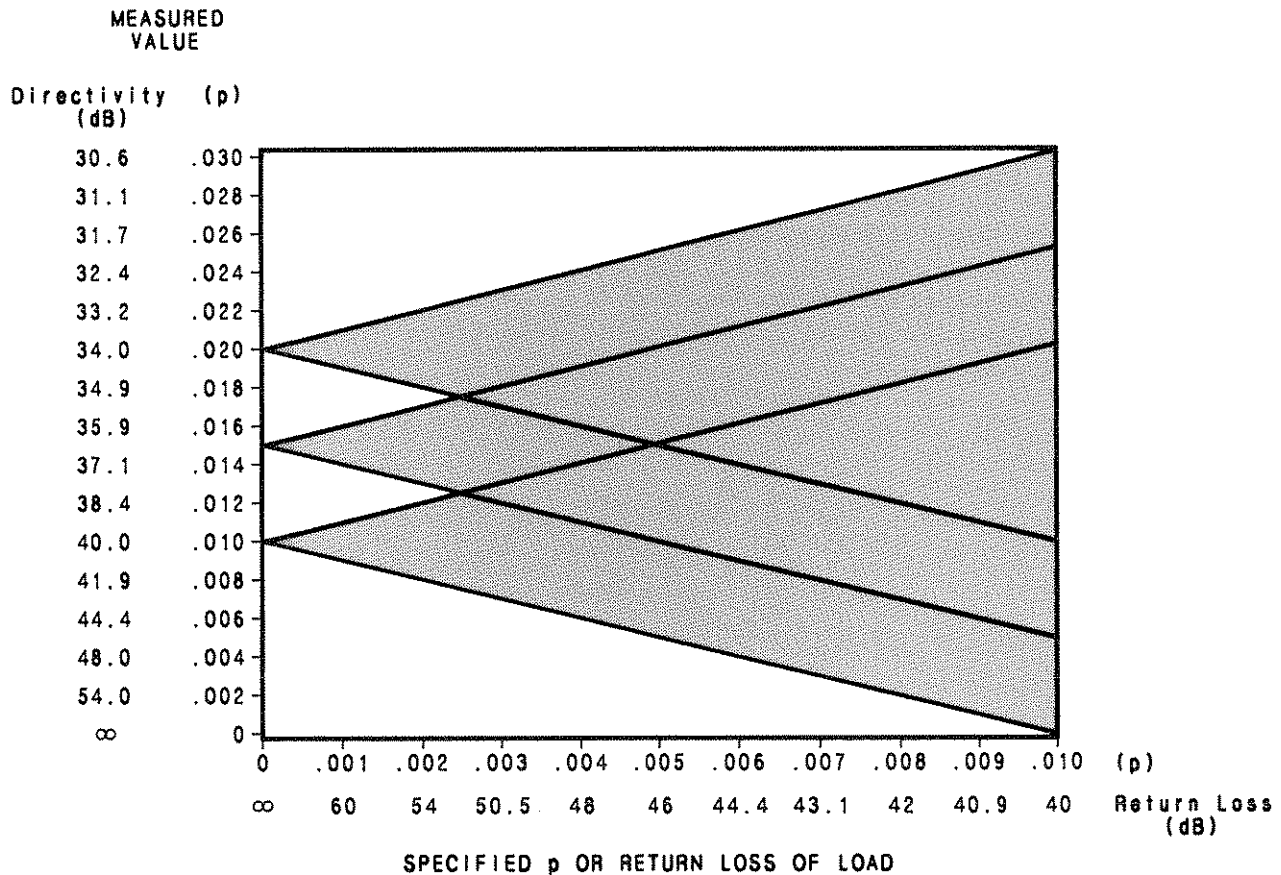

*Figure 4-2. Probable Range of Measurable Directivity Values*

6. Refer to Figure 4-2. The shaded areas in this figure represent the probable range of measurable values for each of the three specified directivity values: 34 dB, 36 dB and 40 dB. On the horizontal axis, locate the fixed load's reflection coefficient or its specified return loss (convert from SWR if necessary). Move up from this point to the upper limit of the shaded area between the appropriate diagonal lines. Allowing for load error, any directivity measurement that falls below this upper limit indicates with 90% probability that the HP 85027 is within specifications. If

the bridge does not meet specifications, perform the troubleshooting procedures outlined in Section 8.

**Above 2 GHz:**

7. On the sweep oscillator, set the start and stop frequencies to match line 2 of Table 4-1, Directivity Performance Test Record.
8. Perform a short/open calibration.
9. Connect the sliding load to the test port of the bridge. (Refer to the sliding load's Operating and Service Manual if need be.)
10. On the HP 8757A press [AUTOSCALE] to position the trace on the display. Slowly move the sliding load back and forth: the trace should change slightly as the phase of the sliding load reflection changes. For several frequencies on the display, note the maximum and minimum measured return loss for various sliding load positions.
11. For each frequency, the maximum and minimum measured return loss values correspond to the directivity signal and the sliding load signal adding and subtracting. You can separate these two signals with the Signal Separation Chart, Figure 4-3. Calculate the **difference** in dB between the maximum and minimum measured return loss for each frequency and locate this value on the vertical axis of Figure 4-3. Draw a horizontal line across the chart from the point just located and note the two places where it intersects the curves. The intersections are the two correction values in dB. Add each of them to the **minimum** measured return loss. The resulting two corrected values are the directivity signal and the sliding load reflected signal.

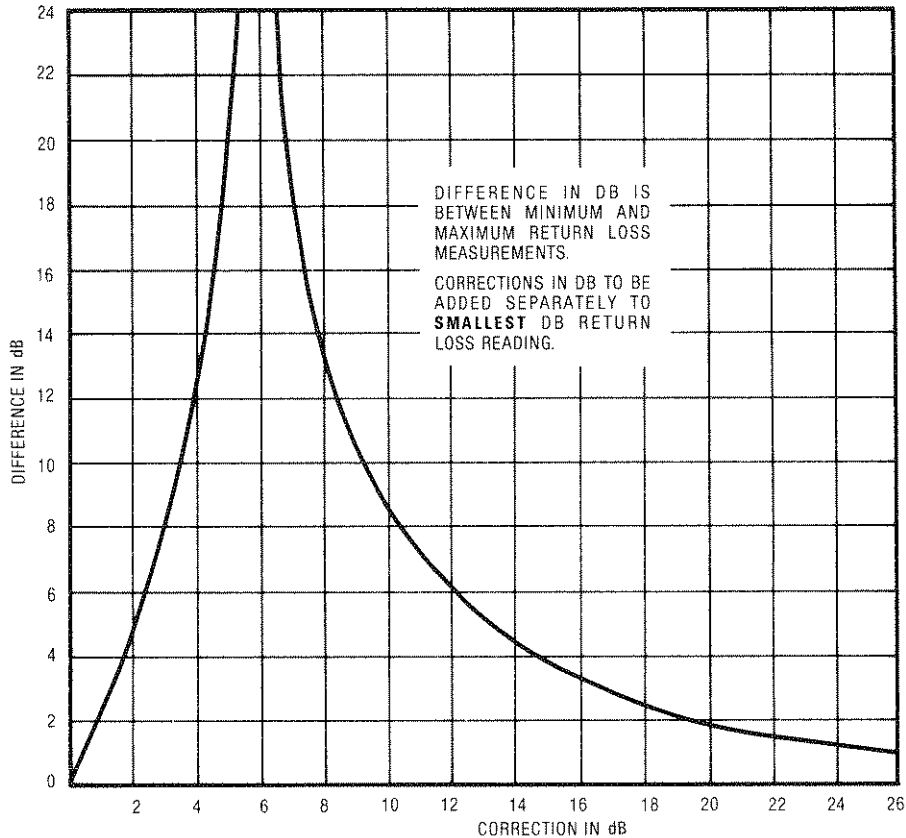

Figure 4-3. Signal Separation Chart

12. Usually the larger return loss value is the measured directivity error. You can verify this by performing the following step.
13. Slowly retract the center conductor of the sliding load about 2mm. This will introduce a discontinuity at the HP 85027 test port and change the measured directivity. Repeat steps 10 and 11 above. After the signals are separated, one of the two should match one of the two separated signals from the first measurement. The matching value is the return loss of the sliding load. The other separated value from the first measurement is the directivity of the HP 85027.
14. Enter the directivity on the Directivity Performance Test Record, Table 4-1.
15. Although the signal separation procedure removes reflections of the load itself, the mismatch of the sliding load connector and airline introduces reflections and uncertainties. To estimate these uncertainties, refer to Figure 4-2. Locate the specified return loss of the sliding load airline and connector on the horizontal axis (convert from SWR). Move up from this point to the upper limit of the bridge specified directivity corresponding to the sliding load's return loss for this frequency range. Enter this value in Table 4-1.
16. Set the start and stop frequencies of the source to the next band of interest in Table 4-1. Repeat steps 8 through 15.

HP 85027A/B/C Performance Tests

Table 4-1. Directivity Performance Test Record

HP 85027		
Frequency Band (GHz)	Scalar Sum of Directivity Signals	Upper Limit (from Figure 4-2)
0.01-2.0	_____	_____
2.0-12.4	_____	_____
12.4-18.0	_____	_____
18.0-20.0*	_____	_____
20.0-26.5*	_____	_____
*HP 85027B only		



## TEST PORT MATCH

### Specifications

The test port match specifications are incorporated in Table 4-2, Test Port Match Performance Test Record, below.

### Description

Using a typical reflection measurement setup, as shown in Figure 4-4, a second directional bridge is used to measure the TEST PORT of the bridge under test. The bridge under test must be biased by the HP 8757A and its RF IN PORT must be properly terminated.

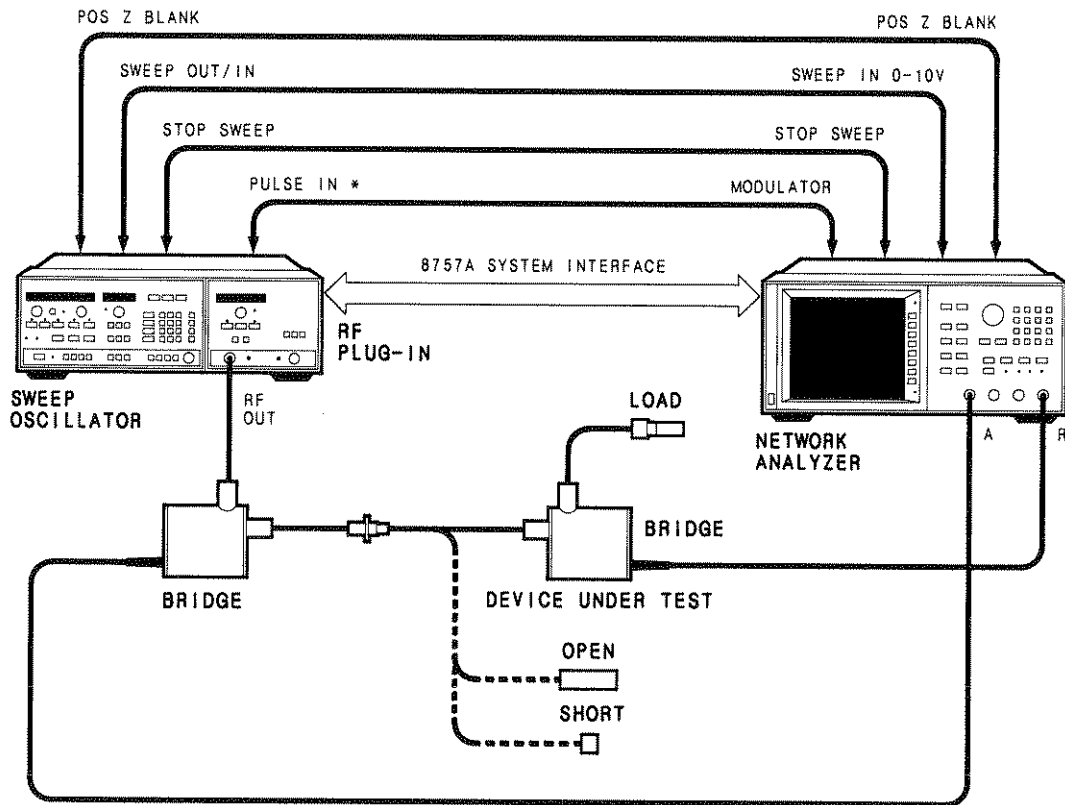

Figure 4-4. Test Port Match Performance Test Setup

## HP 85027A/B/C Performance Tests

### Equipment

	HP 85027A	HP 85027B	HP 85027C
Sweep oscillator	HP 8350B	HP 8350B	HP 8350B
RF plug-in	HP 83592A	HP 83595A	HP 83592A
Scalar network analyzer	HP 8757A	HP 8757A	HP 8757A
Cal. open/short	85021-60021	85037-60001	85032-60001
50 ohm load	909A opt 012	909D	909A opt 012
Adapter*	not req'd	85027-60002	1250-1475

\*A second directional bridge is required as a test instrument in addition to the directional bridge under test. The adapters recommended are suitable for use with two similar bridges.

### Procedure

1. Set up the equipment as shown in Figure 4-4, with the calibrated open connected to the test directional bridge, not the directional bridge under test.
2. PRESET the analyzer. It should indicate that Input A is on Channel 1. Turn off Channel 2. The Preset should also preset the sweep oscillator to a sweep time of 200 ms with 27.8 kHz modulation on.
3. Set the sweep oscillator start and stop frequencies to correspond to the first band of frequencies in the Performance Test Record (0.01 to 8.4 GHz).
4. Perform an open/short calibration and store it in memory.
5. Connect the directional bridge under test to the first directional bridge, test port to test port with an adapter if necessary. Connect the 50 ohm load to the input port of the directional bridge under test.
6. On the HP 8757A turn on the cursor and press the [MAX] softkey to find the point of minimum return loss (highest point) on the trace. Enter this value on the Performance Test Record.
7. Repeat steps 3 through 7 for each frequency band of interest.
8. If the test results (including uncertainties) are not within specifications as indicated on the Test Port Match Performance Test Record, refer to the Troubleshooting section of this manual.

*Table 4-2. Test Port Match Performance Test Record*

Frequency Band (GHz)	HP 85027A		HP 85027B		HP 85027C	
	Spec.	Test Result	Spec.	Test Result	Spec.	Test Result
0.01-8.4	>=23 dB	_____	>=23 dB	_____	>=23 dB	_____
8.4-12.4	>=19 dB	_____	>=15 dB	_____	>=19 dB	_____
12.4-18.0	>=17 dB	_____	>=15 dB	_____	>=17 dB	_____
18.0-20.0	--		>=15 dB	_____	--	
20.0-26.5	--		>=11 dB	_____	--	
Uncertainty*	1 dB		1dB		2 dB	

\*Approximate uncertainty excluding effect of any adapter used.

**DYNAMIC POWER ACCURACY (AC and DC)**

**Specifications**

The dynamic power accuracy specifications for the bridge in AC mode are incorporated in Table 4-3, Dynamic Power Accuracy, which follows.

**Description**

Using the setup illustrated in Figure 4-5 to measure the dynamic power accuracy of the HP 85027.

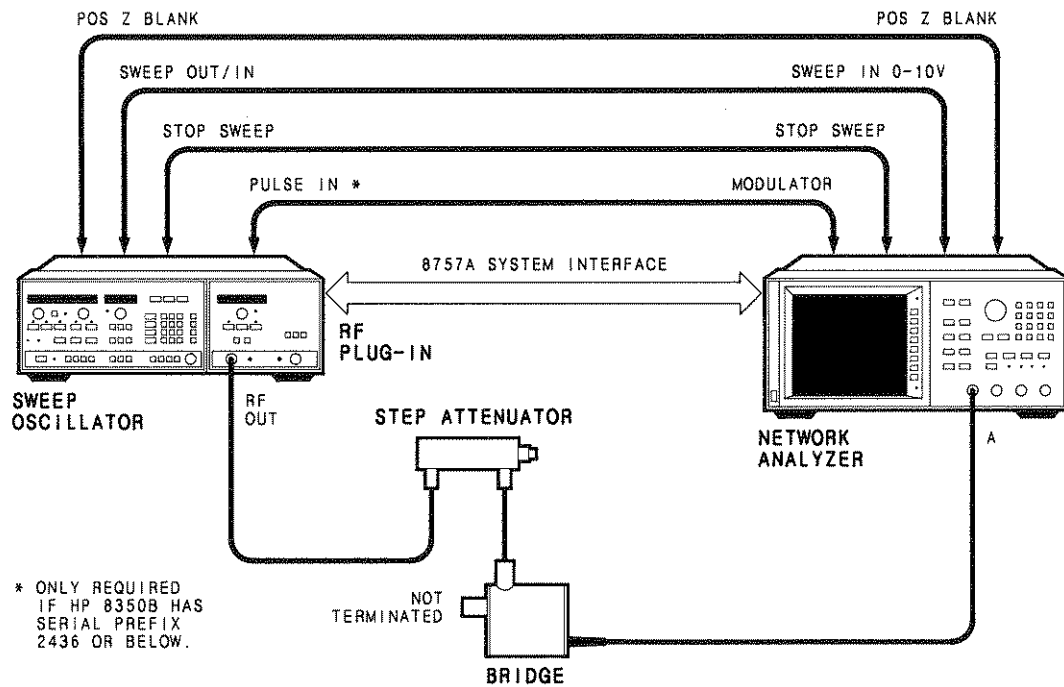

Figure 4-5. Dynamic Power Accuracy Performance Test Setup

**Equipment**

	HP 85027A	HP 85027B	HP85027C
Sweep Oscillator	HP 8350B	HP 8350B	HP 8350B
RF Plug-in	HP 83592A	HP 83595A	HP 83592A
Scalar network analyzer	HP 8757A	HP 8757A	HP 8757A
Short/open Adapter(s)	85021-60001 1250-1475	85037-60001 85027-60002	11512A/85033-60001 1250-1475
Step attenuator	8495B opt 001	8495D opt 004	8495B opt 001

**Procedure**

1. Set up the equipment as shown in Figure 4-5, preset the instruments and allow 30 minutes for warm-up.
2. Adjust the RF plug-in as required to output +7 dBm at 50 MHz CW.
3. Set the attenuator to 0 dB attenuation.
4. On the analyzer, turn on the cursor and press [MEAS-->MEM] and [MEAS-MEM]. This should result in a 0 dB reading.
5. Step down the attenuator 10 dB at a time and note the cursor readings on the appropriate lines of Table 4-3.
6. All of the test results should be within the specifications as tabulated in column two of Table 4-3. However there is a source of error which can adversely affect the results. This error is that of attenuator inaccuracy: the attenuator at a nominal setting of, say 10 dB, may not actually attenuate 10 dB.

To overcome this error, refer to the attenuator's calibration data and use the actual attenuation value for each setting.

7. If after removing the source of error from the test results as noted above you believe that the bridge still does not meet its specifications, refer to Section 8, Troubleshooting.
8. If you are using an HP 8757A with the bridge and wish to test its DC dynamic power accuracy, return to the SYSTEM menu, select DC mode and perform a short/open calibration by pressing these keys: [SYSTEM] [MODE] [CAL] [SHORT/OPEN] [DISPLAY] and [MEAS-MEM].
9. Perform steps 3 through 8 and enter the results in the fourth column of Table 4-3.

*Table 4-3. Dynamic Power Accuracy Performance Test Record*

Delta Power Nominal	Power Actual	AC/DC Spec	AC Test Result	DC Test Result
0 dB	_____	Ref	Ref	Ref
-10 dB	_____	-10±0.4 dB	_____	_____
-20 dB	_____	-20±0.4 dB	_____	_____
-30 dB	_____	-30±0.5 dB	_____	_____
-40 dB	_____	-40±1.0 dB	_____	_____

SECTION 5  
ADJUSTMENTS

INTRODUCTION

You do not have to make any adjustments to the HP 85027 for regular calibration or normal use. However, if you repair or replace the internal bridge microcircuit assembly (A1) or the circuit board assembly (A2), you must make the following adjustments to match the preamplifier to the characteristics of the microcircuit. Additionally, if the HP 85027 does not pass one of its performance tests you may need to perform the adjustments in this section.

ADJUSTMENT PROCEDURES

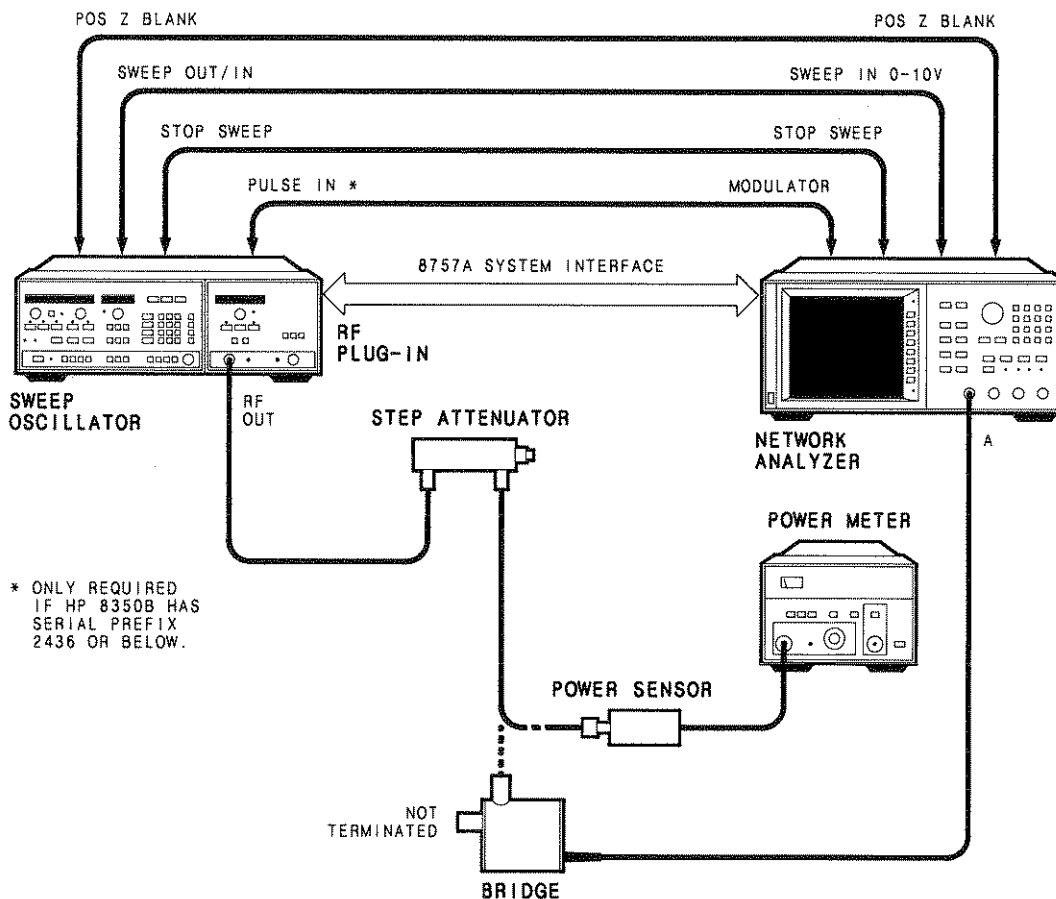

Figure 5-1. Adjustment Setup

Note: to perform the following adjustments refer to Figure 5-2 for the locations of the adjustment potentiometers.

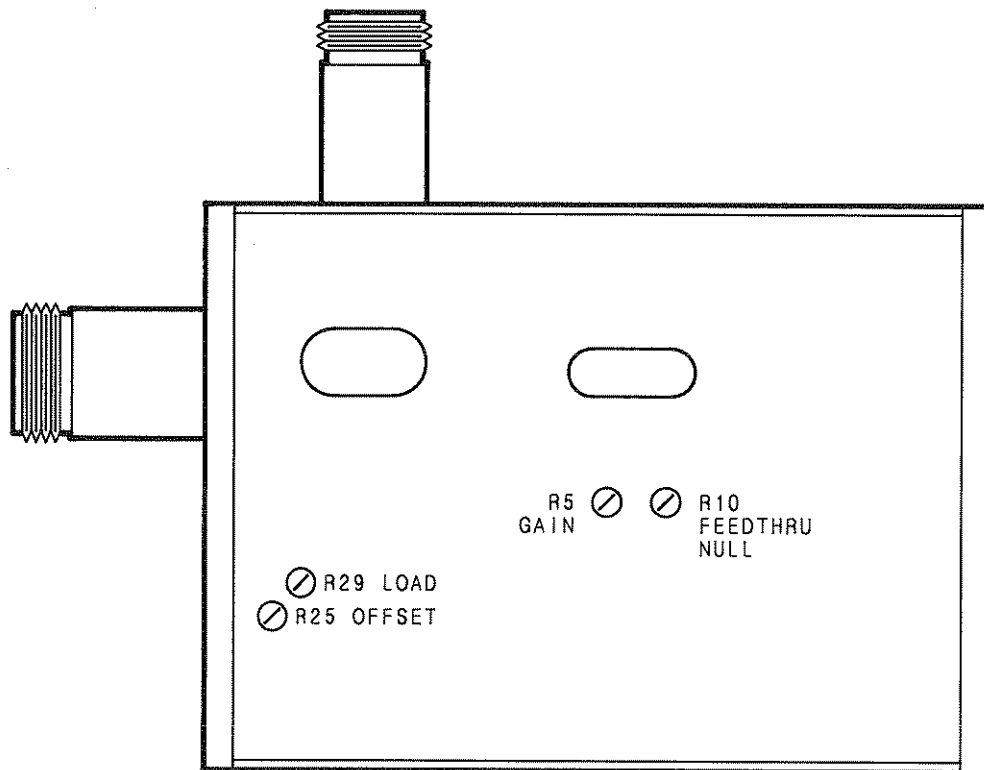

Figure 5-2. Locations of Adjustment Potentiometers

### AC Adjustment Procedure

1. Set up the equipment as shown in Figure 5-1. Turn on the analyzer, source and power meter and allow 30 minutes for warm-up. Refer to Figure 5-2 for locations of the adjustments.
2. Connect the power meter sensor to the calibrated 10 dB step attenuator.

#### NOTE

If your attenuator does not have calibration data, determine exactly how much the attenuation changes between the 0dB and 30dB settings. Determine this with the source set for about +13 dBm at 50 MHz CW. Use this figure when the procedure refers to calibrated 30 dB; for example, 29.9 dB or 30.06 dB.

3. Set the attenuator for 0 dB.
4. Preset the analyzer. Set the source to generate 50 MHz CW without modulation. Adjust the output for a reading of +6.5 dBm on the power meter and then turn on the modulation.

## HP 85027A/B/C Adjustments

5. On the back of the bridge is a printed, self-adhesive plastic label with a note that explains the switch configuration. Remove the label. (Note: additional labels may be ordered as P/N 85027-80004.)
6. Disconnect the power sensor from the attenuator. Turn on the modulation (note: the modulation frequency must be correct). Connect the input port of the bridge to the attenuator. Leave the test port open.
7. On the HP 8757A or 8756A, turn on the averaging (8, default factor) and cursor. On the also HP 8757A turn on the smoothing (5%, default factor).
8. Adjust the bridge's gain potentiometer (R5) for a cursor reading of  $-6 \pm 0.1$  dBm.
9. Set the attenuator for 30 dB. Adjust the bridge's load potentiometer (R29) for a cursor reading of **calibrated**  $-30$  dB minus  $6 \pm 0.1$  dBm.
10. Set the attenuator to 0 dB and readjust the gain potentiometer (if required) until the cursor indicates  $-6 \pm 0.1$  dBm.
11. Repeat steps 8 through 10 until the change in level is equal to the **calibrated** 30 dB  $\pm 0.1$  dB and the cursor with 0 dB attenuation indicates  $-6 \pm 0.1$  dBm.

### DC Adjustment Procedure

#### NOTE

This DC procedure can be performed only with an HP 8757A analyzer.

12. Set the HP 8757A to DC mode.
13. Set the analyzer's reference level to -50 dBm at midscreen with a scale of 5 dB/division.
14. Turn off the RF power from the source.
15. Configure the system by pressing [CAL] [CONFIG SYSTEM] on the analyzer.
16. On the bridge, temporarily short pad "Y" (where the yellow wire terminates) to ground with a short jumper.
17. Adjust the bridge Offset potentiometer (R25) for a minimum reading on the analyzer. It should be less than -50 dBm.
18. Remove the short completely.

### Feedthru Null Adjustment Procedure

19. Press [SYS] [CAL] [DC DET ZERO] [AUTOZERO] on the HP 8757A. Note that for the AUTOZERO feature to function, the analyzer and source must be connected through the System Interface.
20. Adjust the bridge "feedthru null" potentiometer (R10) for as **HIGH** a trace as possible. Work slowly as the averaging and smoothing features will mask the effects of your adjustments.

NOTE

Steps 19 and 20 must be repeated until no further change is noted.

DC Mode RF Adjustment Check

21. Turn on the source RF.
22. Connect the power meter sensor to the calibrated 10 dB step attenuator.
23. Set the attenuator for 0 dB.
24. Preset the source. Set it to generate 50 MHz CW without modulation. Adjust the output for a reading of +6.5 dBm on the power meter.
25. Disconnect the power sensor from the attenuator. Connect the input port of the bridge to the attenuator. Leave the test port open.
26. On the analyzer, confirm that smoothing (5%, default factor), averaging (8, default factor) and the cursor are on.
27. **ONLY if the cursor does not indicate  $-6 \pm 0.8$  dBm**, adjust the bridge's gain potentiometer (R5) for a cursor reading of  $0 \pm 0.8$  dB.
28. Set the attenuator for 30 dB. **Only if the cursor does not indicate calibrated  $-30$  minus  $6 \pm 0.8$  dBm**, adjust the bridge's load potentiometer (R29) for that cursor reading.
29. Set the attenuator to 0 dB and readjust the gain potentiometer (if required) until the cursor indicates  $-6 \pm 0.8$  dBm.
30. Repeat steps 27 through 30 **ONLY** until the change in level is equal to the **calibrated 30 dB  $\pm 0.8$  dB** and the cursor with 0 dB attenuation indicates  $-6$  dB  $\pm 0.8$  dB.



## SECTION 6

### REPLACEABLE PARTS

#### INTRODUCTION

This section contains information for ordering parts. Table 6-1 lists the exchange assemblies available. Table 6-2 lists (1) the names and addresses of manufacturers which correspond to the manufacturers' code numbers and (2) reference designator definitions and abbreviations used in the replaceable parts list. Tables 6-3A, 6-3B and 6-3C are the replaceable parts lists for the HP 85027A, 85027B and 85027C respectively. They list the replaceable parts in reference designator order. Table 6-4 lists the replaceable parts of A2 Circuit Board, common to all three bridges.

Figures 6-1A, 6-1B and 6-1C show the major assembly and miscellaneous parts locations for the 3 bridges. The circuit board assembly (A2) for all 3 bridges is the same. Figure 6-2 shows the component side, Figure 6-3 shows the solder side, Table 6-2 lists its replaceable parts.

#### EXCHANGE ASSEMBLIES

You may replace, on an exchange basis, the bridge microcircuit assembly and realize a considerable cost saving. This assembly includes the input and test port connectors and the reference termination. Table 6-1 lists these factory repaired and tested assemblies and their HP part numbers. The defective assemblies must be returned for credit to realize the cost savings. Thus, assemblies required for spare parts stock must be ordered by the new assembly part number.

#### REPLACEABLE PARTS LIST

##### Organization

Table 6-3 is the list of replaceable parts and is organized as follows:

- a. Electrical assemblies and their components in alpha-numerical order by reference designation.
- b. Major assemblies and cables.
- c. Options.
- d. Miscellaneous (including mechanical and attaching hardware) parts.

##### Information

The following information is tabulated for each entry:

- a. The Hewlett-Packard part number.
- b. The part number check digit (CD).
- c. The total quantity (Qty) in the instrument or, if accompanied by an illustration, the total quantity illustrated therein.
- d. The description of the part.

## HP 85027A/B/C Replaceable Parts

- e. The five digit code of the typical manufacturer of the part.
- f. The manufacturer's part number for the part.

### NOTE

The total quantity for each part is given only once, at the first appearance of the part in the list.

### ORDERING INFORMATION

To order a part listed in the Replaceable Parts List, indicate the Hewlett-Packard part number (with check digit to ensure efficient processing) and the quantity desired. Address the order to the nearest Hewlett-Packard office.

To order a part that is not listed in the Replaceable Parts List, include the instrument model and serial number, the description and function of the part and the quantity desired. Address the order to the nearest Hewlett-Packard office.

*Table 6-1. Exchange Microcircuit Bridge Assemblies*

BRIDGE	NEW PART NUMBER	EXCHANGE (REBUILT) PART NUMBER
HP 85027A	5086-7376	5086-6376
HP 85027B	5086-7377	5086-6377
HP 85027C	5086-7399	5086-6399

*Table 6-2. Manufacturers Code List, Reference Designators and Abbreviations*

MANUFACTURERS CODE LIST			
Code	Manufacturer	Address	Zip Code
04713	Motorola Semiconductor Products	Phoenix AZ	85008
06383	Panduit Corp	Tinley Park IL	60477
06665	Precision Monoliths Inc	Santa Clara CA	95050
24546	Corning Glass Works (Bradford)	Bradford PA	16701
25088	Siemens Corp	Iselin NJ	08830
27014	National Semiconductor Corp	Santa Clara CA	95051
28480	Hewlett-Packard Co Corporate HQ	Palo Alto CA	94304
32997	Bourns Inc Trimpot Prod Div	Riverside CA	92507

REFERENCE DESIGNATORS	
A assembly	R resistor
AT termination assembly	TP test point
C capacitor	S switch
CR diode	U integrated circuit
J jack	VR diode
L inductor	W cable
MP miscellaneous part	

ABBREVIATIONS

ADJ	adjustable	RMS	root-mean-square
ASSY	assembly	SGL	signal
BD	board	SI	silicon
CER	ceramic	SIG	signal
DBLHX	double camfered, hex	SLDR	solder
FXD	fixed	STR	straight
G	giga ( $10^9$ )	TA	tantalum
K	1000	THD	thread
MA	milli-amp	TML	terminal
MEG	million ( $10^6$ )	TRMR	trimmer
MFR	manufacturer	TRN	turn
MHZ	megahertz	UF	microfarad
PF	picofarad	VDC	volts, direct current
PRCN	precision	W	watt
RGLTR	regulator	ZNR	zener

# HP 85027A/B/C Replaceable Parts

*Table 6-3A. HP 85027A Replaceable Parts*

Reference Designation	HP Part Number	C D	Qty	Description	Mfr Code	Mfr Part Number
85027A REPLACEABLE PARTS						
A1	5086-7376	4	1	BRIDGE MICROCIRCUIT ASSEMBLY (NEW)	28480	5086-7376
A1	5086-6376	2		BRIDGE MICROCIRCUIT ASSEMBLY (REBUILT)	28480	5086-6376
A2**	85027-60001	2	1	CIRCUIT BOARD ASSEMBLY	28480	85027-60001
AT1	P/O A1		1	TERMINATION CARTRIDGE	28480	P/O A1
J1	P/O A1		1	INPUT CONNECTOR	28480	P/O A1
J2	P/O A1		1	TEST PORT CONNECTOR	28480	P/O A1
J2MP1	1250-1837	5	1	BARREL-RF CONNECTOR 15.9MM DIA X 30 MM	28480	1250-1837
J2MP2	1250-1465	5	1	COMPONENT-RF CONNECTOR APC-7 COUPLING	28480	1250-1465
J2MP3	1250-1839	7	1	CONTACT-RF CONNECTOR APC-7 SERIES	28480	1250-1839
MP1	85027-00001	6	1	DRESS COVER	28480	85027-00001
MP2	85027-20005	2	1	CABLE COVER	28480	85027-20005
MP3	85027-20003	0	1	EXTRUDED HOUSING	28480	85027-20003
MP4	85027-20004	1	1	PORT COVER	28480	85027-20004
MP5	0535-0694	3	1	NUTM-DBLHX	28480	0535-0694
MP6	2190-0584	0	4	LOCKWASHER M3.0	28480	2190-0584
MP7	0369-1190	3	2	TML STUD SGL-PIN	28480	0369-1190
MP8	0515-1417	8	4	SCREW-THD-RLG M3 X 0.5 10MM-LG	28480	0515-1417
MP9	1531-0289	5	1	MACHINED PART-SST SPACER-BRIDGE	28480	1531-0289
MP10	0515-0820	5	8	SCREW-MACH M2 X 0.4 5MM-LG 90-DEG-FLH-HD	28480	0515-0820
MP11	0515-0820	5		SCREW-MACH M2 X 0.4 5MM-LG 90-DEG-FLH-HD	28480	0515-0820
MP12	85027-80001	4	1	ID LABEL 85027A	28480	85027-80001
MP13*	1400-0249	0	1	CABLE TIE .062-.625-DIA .091-WD NYL	06363	PLT1M-8
MP14	85027-80009	2	1	INSTRUMENT CASE	28480	85027-80009
MP15*	85027-80012	7	1	FOAM PAD	28480	85027-80012
MP16				NOT ASSIGNED		
MP17	9211-0126	9	1	CARTON-CORR RSC 11.5-IN-LG 8.625-IN-WD	28480	9211-0126
MP18*	85027-80004	7	1	LABEL IN RF IN TEST	28480	85027-80004
MP19	85027-80005	8	1	LABEL WARNING MAXIMUM INPUT	28480	85027-80005
MP20	85027-80006	9	1	LABEL ID 85027A	28480	85027-80006
MP21				NOT ASSIGNED		
MP22*	1250-1475	7	1	ADAPTER-COAX STR M-PRCN N M-PRCN N	28480	1250-1475
MP23*	85021-60001	6	1	7MM OPEN/SHORT ASSEMBLY	28480	85021-60001
W1	85025-60003	2	1	CABLE ASSY	28480	85025-60003
	85027-90001	5	1	OPERATING AND SERVICE MANUAL	28480	85027-90001
*NOT SHOWN						
**SEE TABLE 6-4						

See introduction to this section for ordering information.

\*Indicator factory selected value.

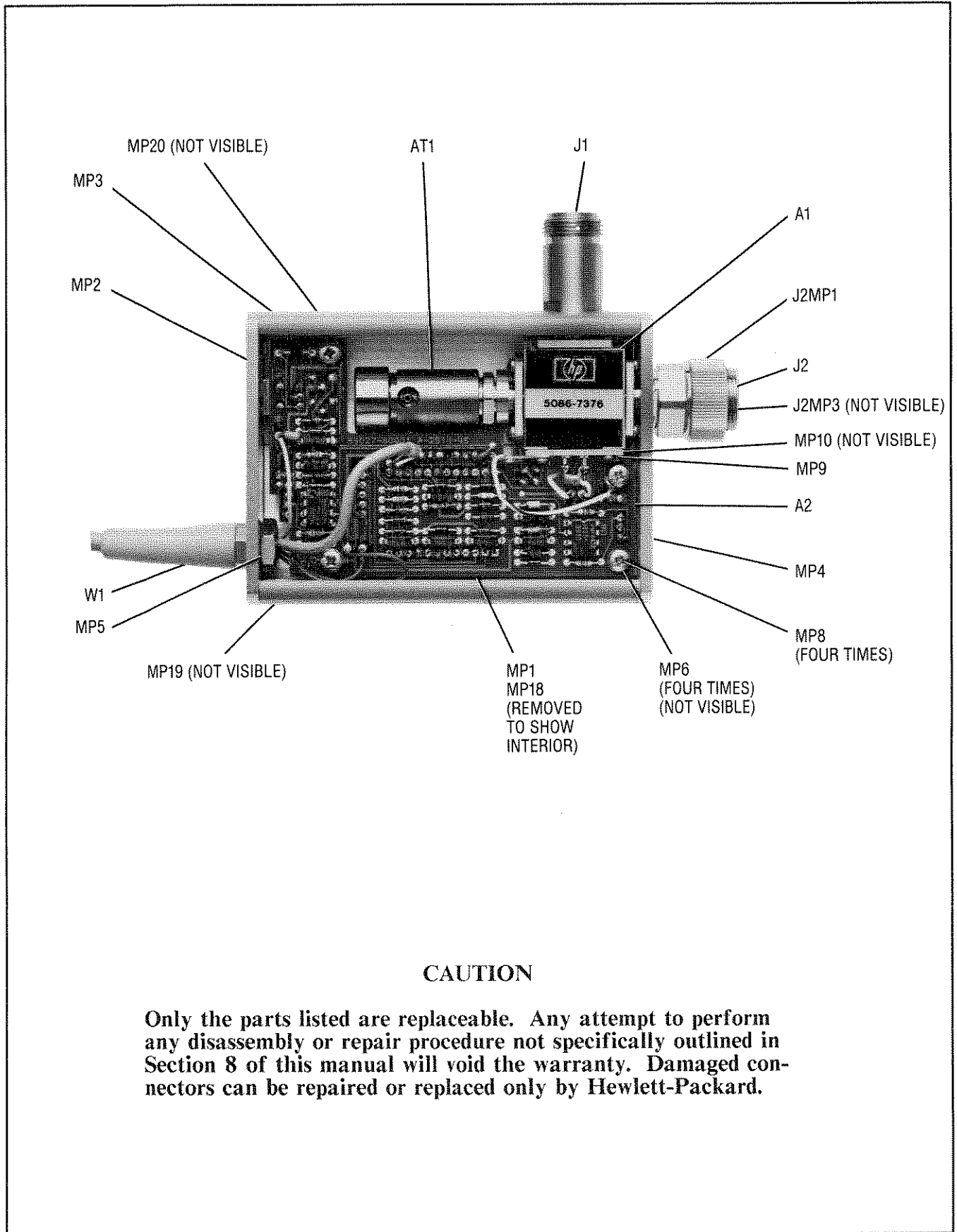

**CAUTION**

Only the parts listed are replaceable. Any attempt to perform any disassembly or repair procedure not specifically outlined in Section 8 of this manual will void the warranty. Damaged connectors can be repaired or replaced only by Hewlett-Packard.

Figure 6-1A. HP 85027A Replaceable Parts Identification

# HP 85027A/B/C Replaceable Parts

*Table 6-3B. HP 85027B Replaceable Parts*

Reference Designation	HP Part Number	C D	Qty	Description	Mfr Code	Mfr Part Number
				85027B REPLACEABLE PARTS		
A1	5086-7377	5	1	BRIDGE MICROCIRCUIT ASSEMBLY (NEW)	28480	5086-7377
A1	5086-6377	3		BRIDGE MICROCIRCUIT ASSEMBLY (REBUILT)	28480	5086-6377
A2**	85027-60001	2	1	CIRCUIT BOARD ASSEMBLY	28480	85027-60001
AT1	P/O A1		1	TERMINATION CARTRIDGE	28480	P/O A1
J1	P/O A1		1	INPUT CONNECTOR	28480	P/O A1
J2	P/O A1		1	TEST PORT CONNECTOR	28480	P/O A1
MP1	85027-00001	6	1	DRESS COVER	28480	85027-00001
MP2	85027-20005	2	1	CABLE COVER	28480	85027-20005
MP3	85027-20003	0	1	EXTRUDED HOUSING	28480	85027-20003
MP4	85027-20004	1	1	PORT COVER	28480	85027-20004
MP5	0535-0694	3	1	NUTM-DBLHX	28480	0535-0694
MP6*	85027-00002	7	1	WRENCH, CONNECTOR-SAVER	28480	85027-00002
MP7	0360-0002	6	1	TERMINAL-SLDR LUG PL-MTG FOR-#2-SCR	28480	0360-0002
MP8	0515-1445	2	4	SCREW-THD-RLG M3 X 0.5 8MM-LG	28480	0515-1445
MP9	1531-0289	6	1	MACHINED PART-SST SPACER-BRIDGE	28480	1531-0289
MP10	0515-0820	5	4	SCREW-MACH M2 X 0.4 5MM-LG 90-DEG-FLH-HD	28480	0515-0820
MP11	0515-0912	6	4	SCREW-MACH 3.0 X 8MM PN PD	28480	0515-0912
MP12*	85027-80002	5	1	ID LABEL 85027B	28480	85027-80002
MP13*	85027-80012	7	1	FOAM PAD	28480	85027-80012
MP14*	85027-80010	5	1	INSTRUMENT CASE	28480	85027-80010
MP15	2190-0584	0	4	LOCK WASHER M3.0	28480	2190-0584
MP16	85027-80007	0	1	LABEL ID 85027B	28480	85027-80007
MP17*	9211-0126	9	1	CARTON-CORR RSC 11.5-IN-LG 8.625-IN-WD	28480	9211-0126
MP18	85027-80004	7	1	LABEL IN RF IN TEST	28480	85027-80004
MP19	85027-80005	8	1	LABEL WARNING MAXIMUM INPUT	28480	85027-80005
MP20				NOT ASSIGNED		
MP21*	85027-60002	3	1	ADAPTER M 3.5 M 3.5	28480	85027-60002
MP22*	85027-60003	4	1	ADAPTER M 3.5 F 3.5	28480	85027-60003
MP23*	85037-60001	4	1	3.5MM OPEN/SHORT ASSEMBLY	28480	85037-60001
W1	85025-60003	2	1	CABLE ASSY	28480	85025-60003
	85027-90001	5	1	OPERATING AND SERVICE MANUAL	28480	85027-90001
				* NOT SHOWN		
				**SEE TABLE 6-4		

See Introduction to this section for ordering information.

\*Indicates factory selected value.

# HP 85027A/B/C Replaceable Parts

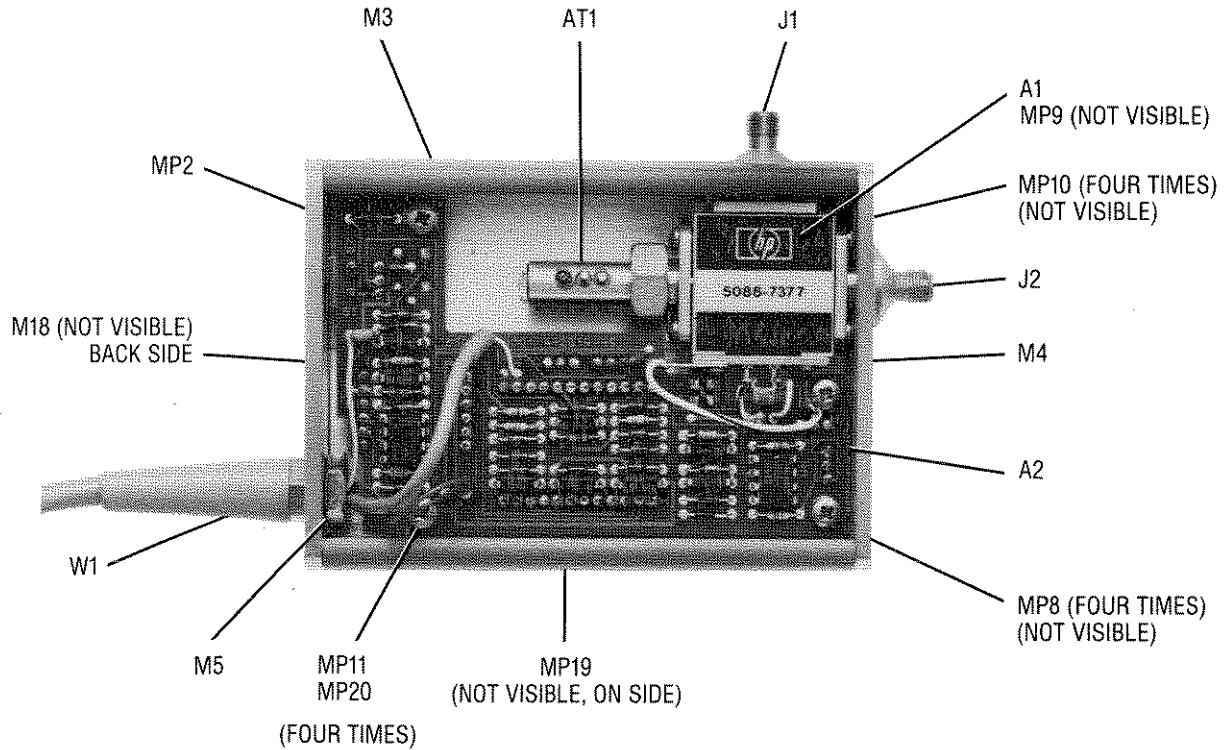

## CAUTION

**Only the parts listed are replaceable. Any attempt to perform any disassembly or repair procedure not specifically outlined in Section 8 of this manual will void the warranty. Damaged connectors can be repaired or replaced only by Hewlett-Packard.**

Figure 6-1B. HP 85027B Replaceable Parts Identification

# HP 85027A/B/C Replaceable Parts

## Table 6-3C. HP 85027C Replaceable Parts

Reference Designation	HP Part Number	C D	Qty	Description	Mfr Code	Mfr Part Number
85027C REPLACEABLE PARTS						
A1	5086-7399	1	1	BRIDGE MICROCIRCUIT ASSEMBLY (NEW)	28480	5086-7399
A1	5086-6399	9	1	BRIDGE MICROCIRCUIT ASSEMBLY (REBUILT)	28480	5086-6399
A2*	85027-80001	2	1	CIRCUIT BOARD ASSEMBLY	28480	85027-80001
AT1	P/O A1	1	1	TERMINATION CARTRIDGE	28480	P/O A1
J1	P/O A1	1	1	INPUT CONNECTOR	28480	P/O A1
J2	P/O A1	1	1	TEST PORT CONNECTOR	28480	P/O A1
MP1	85027-00001	6	1	DRESS COVER	28480	85027-00001
MP2	85027-20005	2	1	CABLE COVER	28480	85027-20005
MP3	85027-20003	0	1	EXTRUDED HOUSING	28480	85027-20003
MP4	85027-20004	1	1	PORT COVER	28480	85027-20004
MP5	0535-0694	3	1	NUTM-DBLHX	28480	0535-0694
MP6				NOT ASSIGNED		
MP7				NOT ASSIGNED		
MP8	0515-1417	8	4	SCREW-THD-RLG M3 X 0.5 10MM-LG	28480	0515-1417
MP9	1531-0289	5	1	MACHINED PART-SST SPACER-BRIDGE	28480	1531-0289
MP10	0515-0820	5	4	SCREW-MACH M2 X 0.4 5MM-LG 90-DEG-FLH-HD	28480	0515-0820
MP11	0515-0912	6	4	SCREW-MACH 3.0 X 8MM PN PD	28480	0515-0912
MP12	85027-80003	6	1	ID LABEL 85027C	28480	85027-80003
MP13	1400-0249	0	1	CABLE TIE .062-.625-DIA .091-WD NYL	06383	PLT1M-8
MP14*	9211-4429	3	1	CASE-ACCESS BIRCH 9.71IN-LG 8.76IN-WD	28480	9211-4429
MP15*	85027-80012	7	1	FOAM PAD	28480	85027-80012
MP16	85027-80008	1	1	LABEL ID 85027C	28480	85027-80008
MP17*	85027-80011	6	1	INSTRUMENT CASE	28480	85027-80011
MP18	85027-80004	7	1	LABEL IN RF IN TEST	28480	85027-80004
MP19	85027-80005	8	1	LABEL WARNING MAXIMUM INPUT	28480	85027-80005
MP20	2190-0584	0	4	LOCKWASHER M 3.0	28480	2190-0584
MP21*	1250-1475	7	1	ADAPTER-COAX STR M-PRCN N M-PRCN N	28480	1250-1475
MP22*	11512A	0	1	SHORT "N" MALE	28480	11512A
MP23*	85032-60001	9	1	OPEN CKT ASSY M N	28480	85032-60001
W1	85025-60003	2	1	CABLE ASSEMBLY	28480	85025-60003
	85027-80001	5	1	OPERATING AND SERVICE MANUAL	28480	85027-80001
* NOT SHOWN						
**SEE TABLE 6-4						

See Introduction to this section for ordering information.

\*Indicates factory selected value.



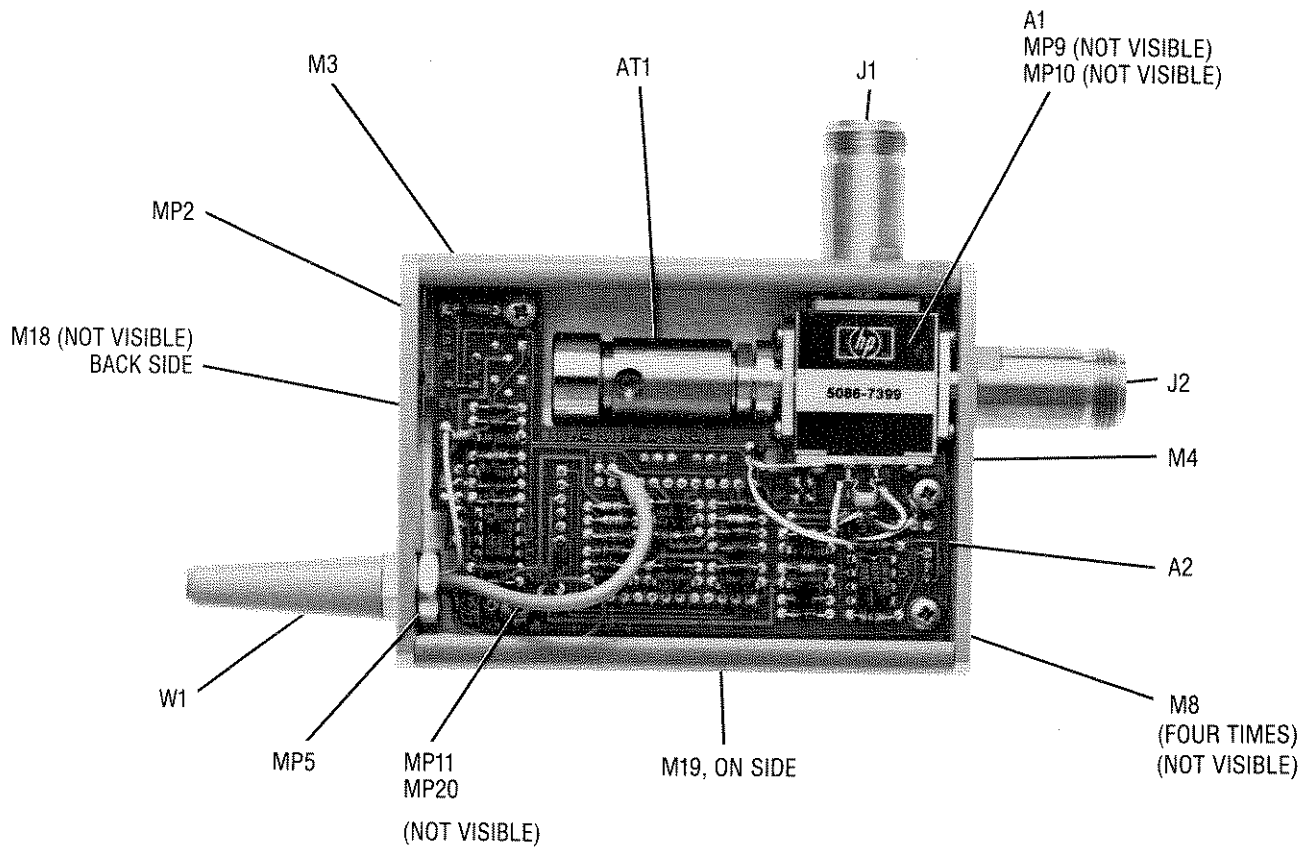

**CAUTION**

Only the parts listed are replaceable. Any attempt to perform any disassembly or repair procedure not specifically outlined in Section 8 of this manual will void the warranty. Damaged connectors can be repaired or replaced only by Hewlett-Packard.

Figure 6-1C. HP 85027C Replaceable Parts Identification

# HP 85027A/B/C Replaceable Parts

## Table 6-4. A2 Bridge Circuit Board Assembly

Reference Designation	HP Part Number	C D	Qty	Description	Mfr Code	Mfr Part Number
				A2 BRIDGE CIRCUIT BOARD ASSEMBLY		
A2	85027-60001	2	1	BRIDGE PC BOARD ASSEMBLY	28480	85027-60001
A2C1	0160-5375	2	8	CAPACITOR-FXD .1UF +-10% 50VDC CER	28480	0160-5375
A2C2	0160-5375	2		CAPACITOR-FXD .1UF +-10% 50VDC CER	28480	0160-5375
A2C3	0160-5375	2		CAPACITOR-FXD .1UF +-10% 50VDC CER	28480	0160-5375
A2C4	0160-5375	2		CAPACITOR-FXD .1UF +-10% 50VDC CER	28480	0160-5375
A2C5	0180-2683	1	1	CAPACITOR-FXD 4.7UF+-20% 35VDC TA	28480	0180-2683
A2C6	0160-5375	2		CAPACITOR-FXD .1UF +-10% 50VDC CER	28480	0160-5375
A2C7	0160-5375	2		CAPACITOR-FXD .1UF +-10% 50VDC CER	28480	0160-5375
A2C8	0160-5375	2		CAPACITOR-FXD .1UF +-10% 50VDC CER	28480	0160-5375
A2C9	0160-5375	2		CAPACITOR-FXD .1UF +-10% 50VDC CER	28480	0160-5375
A2C10	0180-2681	5	2	CAPACITOR-FXD 1UF+-10% 50VDC TA	25088	D1R0GS1A50K
A2C11	0180-2681	5		CAPACITOR-FXD 1UF+-10% 50VDC TA	25088	D1R0GS1A50K
A2C12	0160-0573	2	1	CAPACITOR-FXD 4700PF +-20% 100VDC CER	28480	0160-0573
A2CR1	1901-0050	3	2	DIODE-SWITCHING 80V 200MA 2NS DO-35	28480	1901-0050
A2CR2	1901-0050	3		DIODE-SWITCHING 80V 200MA 2NS DO-35	28480	1901-0050
A2CR3	1901-0539	3	1	DIODE-3M SIG SCHOTTKY	28480	1901-0539
A2MP1	85027-20001	8	1	BD-AC/DC BRIDGE	28480	85027-20001
A2R1	0698-7212	9	7	RESISTOR 100 1% .05W F TC=0+-100	24548	C3-1/8-T0-100R-F
A2R2	0698-7279	8	1	RESISTOR 61.9K 1% .05W F TC=0+-100	24546	C3-1/8-T0-6192-F
A2R3	0698-7249	2	1	RESISTOR 3.48K 1% .05W F TC=0+-100	24546	C3-1/8-T0-3481-F
A2R4	0698-7284	5	1	RESISTOR 100K 1% .05W F TC=0+-100	24546	C3-1/8-T0-100K3-F
A2R5	2100-3091	1	2	RESISTOR-TRMR 2K 10% C TOP-ADJ 17-TRN	32997	3292W-1-202
A2R6	0698-7212	9		RESISTOR 100 1% .05W F TC=0+-100	24546	C3-1/8-T0-100R-F
A2R7	0698-7212	9		RESISTOR 100 1% .05W F TC=0+-100	24546	C3-1/8-T0-100R-F
A2R8	0698-7212	9		RESISTOR 100 1% .05W F TC=0+-100	24546	C3-1/8-T0-100R-F
A2R9	0698-6615	8	1	RESISTOR 75K 1% .05W F TC=0+-100	28480	0698-6615
A2R10	2100-3097	7	1	RESISTOR-TRMR 100K 10% C TOP-ADJ 17-TRN	32997	3292W-1-104
A2R11	0698-7212	9		RESISTOR 100 1% .05W F TC=0+-100	24546	C3-1/8-T0-100R-F
A2R12	0698-7212	9		RESISTOR 100 1% .05W F TC=0+-100	24546	C3-1/8-T0-100R-F
A2R14	0698-7288	9	1	RESISTOR 147K 1% .05W F TC=0+-100	24546	C3-1/8-T0-1473-F
A2R15	0698-7236	7	1	RESISTOR 1K 1% .05W F TC=0+-100	24546	C3-1/8-T0-1001-F
A2R16	0698-7253	8	2	RESISTOR 5.11K 1% .05W F TC=0+-100	24546	C3-1/8-T0-5111-F
A2R17	0698-7212	9		RESISTOR 100 1% .05W F TC=0+-100	24546	C3-1/8-T0-100R-F
A2R18	0698-7229	8	1	RESISTOR 511 1% .05W F TC=0+-100	24546	C3-1/8-T0-511R-F
A2R19	0698-7247	0	1	RESISTOR 2.87K 1% .05W F TC=0+-100	24546	C3-1/8-T0-2871-F
A2R21	0698-7261	8	1	RESISTOR 11K 1% .05W F TC=0+-100	24546	C3-1/8-T0-1102-F
A2R22	0698-7253	8		RESISTOR 5.11K 1% .05W F TC=0+-100	24546	C3-1/8-T0-5111-F
A2R23	0698-7251	6	2	RESISTOR 4.22K 1% .05W F TC=0+-100	24546	C3-1/8-T0-4221-F
A2R24	0698-7251	6		RESISTOR 4.22K 1% .05W F TC=0+-100	24546	C3-1/8-T0-4221-F
A2R25	2100-3091	1		RESISTOR-TRMR 2K 10% C TOP-ADJ 17-TRN	32997	3292W-1-202
A2R28	0698-7224	3	1	RESISTOR 316 1% .05W F TC=0+-100	24546	C3-1/8-T0-316R-F
A2R29	2100-3286	6	1	RESISTOR-TRMR 10K 10% C TOP-ADJ 17-TRN	32997	3292W-1-103
A2R30	0698-7277	6	1	RESISTOR 51.1K 1% .05W F TC=0+-100	24546	C3-1/8-T0-5112-F
A2RT1	0837-0324	6	1	THERMISTOR DISC 2K-OHM TC=-4.4%/C-DEG	28480	0837-0324
A2S1	3101-2851	2	1	SWITCH	28480	3101-2851
A2U1	1NB7-8045	6	1	PREAMP HYBRID ASSEMBLY	28480	1NB7-8045
A2U2	1NB7-8039	8	1	CLOCK HYBRID ASSEMBLY	28480	1NB7-8039
A2U3	1828-0412	1	1	IC COMPARATOR PRCN DUAL 8-DIP-P PKG	27014	LM393N
A2U4	1826-0772	6	1	IC V RGLTR-ADJ-POS 1.2/32V TO-92 PKG	28480	1826-0772
A2U5	1826-0285	6	1	IC V RGLTR TO-92	04713	MC79L05C
A2U6	1826-0932	0	1	IC OP AMP PRCN 8-DIP-C PKG	06665	OP-27FZ
A2VR1	1902-3245	6	2	DIODE-ZNR 21.5V 5% DO-35 PD=.4W	28480	1902-3245
A2VR2	1902-3245	6		DIODE-ZNR 21.5V 5% DO-35 PD=.4W	28480	1902-3245

See introduction to this section for ordering information.

Indicates factory selected value.

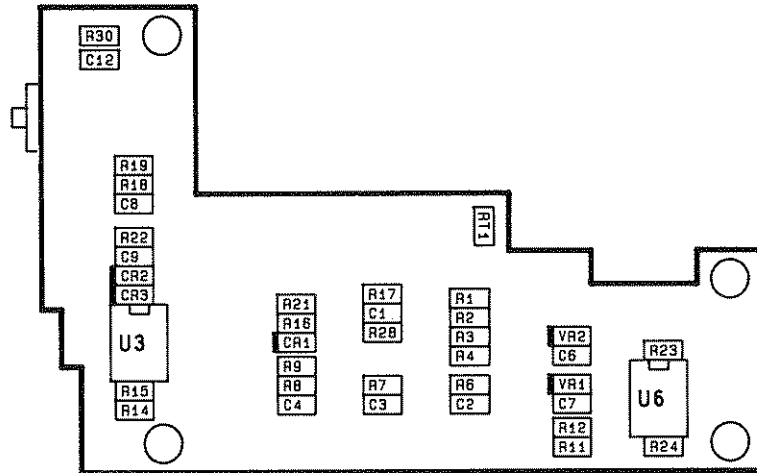

Figure 6-2. A2 Circuit Board Component Location (Component Side)

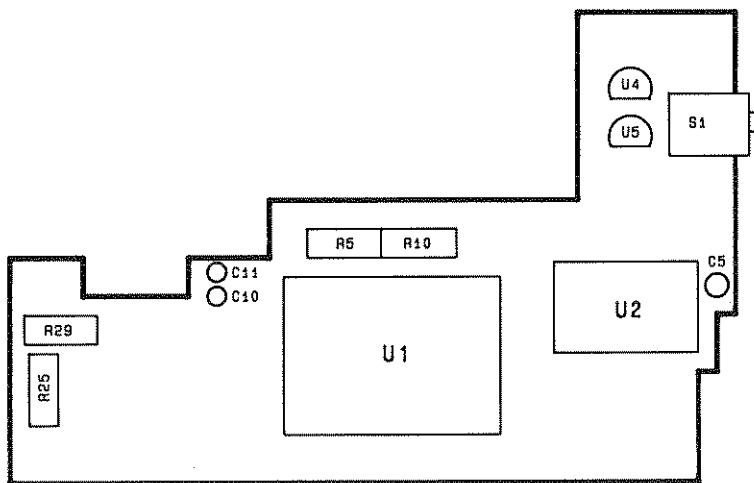

Figure 6-3. A2 Circuit Board Component Location (Solder Side)



## SECTION 7

### MANUAL BACKDATING CHANGES

#### INTRODUCTION

By following the instructions on this page, you can adapt this manual to any instrument with a serial number prefix lower or higher than the one on the title page.

#### APPLICATION

This manual applies directly to instruments with serial number prefixes on the title page. There are no earlier versions of the instrument (with lower serial number prefixes).

To adapt this manual to a later version (higher serial number prefix) instrument, refer to a Manual Changes Supplement. The supplement is keyed to this manual's print date and part number (on the title page) and is available free from Hewlett-Packard.

Additional information about serial number coverage is in Section 1 under INSTRUMENTS COVERED BY THE MANUAL.



## SECTION 8

### SERVICE

#### INTRODUCTION

You will find in this section information concerning troubleshooting and repair of the HP 85027. Heed the caution signs or risk damaging the bridge. You may wish to read the Theory of Operation with its associated diagrams as an aid to troubleshooting.

Troubleshooting the bridge begins with performing the Operator's Check (Section 3) and the Performance Tests (Section 4). If the bridge does not pass the Performance Tests, refer to Adjustments in Section 5. If the problem persists, refer to Troubleshooting Procedures later in this section. Those procedures require the use of test equipment which is listed in Section 1, General Information.

You will also find the following inspection, repair and replacement procedures in this section:

- \* Gaining Internal Access
- \* Cable Continuity Check  
Power Cable Replacement
- \* Input Port and Test Port Resistance Checks
- \* A2 Circuit Board Assembly Replacement
- \* Microcircuit Check  
A1 Bridge Microcircuit Assembly Replacement
- \* Power Supply Check
- \* Signal Path Check
- \* Clock/Control Check
- \* Connector Inspection
- \* HP 85027A APC-7 Connector Repair

#### THEORY OF OPERATION

The HP 85027 can detect RF or microwave signals which are either 27.8 kHz squarewave modulated (AC mode) or unmodulated (DC mode). In both detection modes, the bridge provides a 27.8 kHz square wave signal for the analyzer to interpret and display.

In AC mode, the signal is amplitude modulated at the source. The bridge demodulates (envelop detects) this signal to produce a 27.8 kHz square wave signal whose peak-to-peak voltage corresponds to the magnitude of the signal at the bridge test port. Since only the modulated signal is detected, unmodulated broadband noise and extraneous signals are disregarded. Additionally, this technique provides nearly drift-free operation.

In DC mode, the source signal is not modulated. Instead the bridge converts the signal into an equivalent DC voltage which it then chops at a frequency of 27.8 kHz. Finally it amplifies the chopped signal to simulate the signal produced by AC detection and outputs this signal to the analyzer. This technique is preferable for devices such as some amplifiers with ALC circuits and very narrow bandwidth filters.

## TROUBLESHOOTING PROCEDURES

If a problem persists after you have performed the Operator's Check in Section 3 or the Performance Tests in Section 4, perform the troubleshooting procedures outlined below.

### CAUTION

**The HP 85027 contains microcircuits which are highly sensitive to electrostatic discharge (ESD). Work only at a station equipped with an anti-static surface. Wear a grounded wrist strap. Do not touch the center contacts of the connectors with your fingers. Before you make a measurement, ground the leads of the digital multimeter by touching them to the grounded instrument chassis.**

### Gaining Internal Access

To obtain access to the interior of the HP 85027, proceed as follows:

1. Disconnect the bridge from the analyzer.
2. With the HP 85027A only, use a thin 1/2 inch open-end wrench to remove the coupling nut from the APC-7 test port connector.
3. Remove the two screws which hold the (test) port cover (end plate).
4. Remove the port cover.
5. Slide the top dress cover out of the bridge housing. The component side of the circuit board and the bridge assembly are now accessible.

### Cable Continuity Check

1. Disconnect the HP 85027 from the analyzer and ground the leads of the DMM by touching them to the grounded chassis of the DMM.
2. Use a digital multimeter (DMM) to check the continuity of the conductors of the power cable (W1) from the connector pins to the wire connections inside the bridge housing. Table 8-1 lists the W1 connector pins and the corresponding wires.
3. If there are any discontinuities, replace cable W1 by following the instructions in Power Cable Replacement.

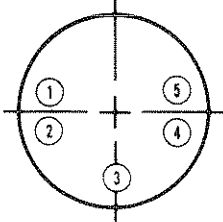

Table 8-1. Conductors in Power Cable W1

	Connector Pin	Conductor (Label)	Signal
	1	White (W)	Output
	2	Green (G)	Return
	3	Yellow (Y)	Control
	4	Blue (B)	-12.6v
	5	Red (R)	+15v

### Power Cable Replacement

1. To replace the power cable (W1), first open the bridge by following the instructions above in "Gaining Internal Access".
2. Unsolder the wires connected to the power cable/circuit board assembly.
3. Remove the two screws from the cable cover end plate.
4. Remove the 1/2 inch hex nut which fastens the cable to the end plate.
5. Replace the cable and reinstall it by performing in reverse order steps 1 through 4. Note that the pads on which the wires are soldered are labeled as indicated in Table 8-1.

### Input Port and Test Port Resistance Checks

1. Disconnect the HP 85027 from the analyzer. Momentarily ground the leads of the DMM by touching them to its grounded chassis.

#### CAUTION

**WORK STATIC-FREE.** ESD can damage the highly sensitive microcircuits in the HP 85027 bridges.

2. Measure the resistance from the center contact of input port connector J1 to the center contact of test port connector J2. The resistance should be  $33 \pm 2$  ohms.
3. Measure the resistance from the center contact of input connector J1 to signal ground (the black/white wire connected to the microcircuit housing). The resistance should be  $83 \pm 2$  ohms.
4. Measure the resistance from the center contact of test port connector J2 to signal ground. It should be  $83 \pm 2$  ohms.
5. If any of the above results are not correct, the bridge microcircuit assembly A1 is defective and must be replaced: refer to "A1 Bridge Microcircuit Assembly Replacement."

### Microcircuit Check

1. Connect the input port of the bridge to the RF out port of the RF plug-in or synthesized sweeper. Do not terminate the bridge test port.

2. Set the RF output to +13 dBm with the modulation on.
3. With a true RMS DMM, measure the voltage across the two output pins of the microcircuit.
4. The bridge diode is probably good if the reading in step 3 is approximately  $0.07V_{\text{rms}}$ .
5. If the reading in step 3 is low, remove the self-adhesive plastic label with the note which explains the switch configuration and center the load potentiometer (R29, see Figure 5-2). Measure again. If the reading remains low, the microcircuit is defective and must be replaced.

### **A2 Circuit Board Assembly Replacement**

1. To remove the circuit board, first open up the bridge and unsolder the power cable wires (see "Gaining Internal Access" and "Power Cable Replacement").
2. At the circuit board pads, unsolder the signal, signal ground and chassis ground wires from the microcircuit.
3. Remove the four screws and lockwashers which fasten the A2 circuit board to the standoffs.
4. Reverse the above procedure to install the repaired or replacement board.
5. Refer to Section 5, Adjustments, and perform them as indicated to match the A2 board to the A1 microcircuit.
6. Reassembly the remaining parts of the bridge.

### **A1 Bridge Microcircuit Assembly Replacement**

1. Type the serial number of the HP 85027 on the rear panel label supplied with the new or replacement bridge assembly.
2. On the HP 85027A only, remove the coupling nut from the APC-7 test port connector with a thin 1/2 inch open-end wrench.
3. Remove the two screws holding the (test) port cover (end plate) and remove the port cover.
4. Remove the two screws holding the cable cover (end plate). This will allow the cable and cable cover to move freely.
5. Unsolder the two white/black wires (signal ground and chassis ground) and the white/red wire (signal) at the microcircuit. Remove the capacitor from the microcircuit pins.
6. Remove the four screws and lockwashers which fasten the A2 Circuit Board Assembly to the standoffs.
7. Remove the A2 Circuit Board Assembly with the cable cover and cable from the extruded housing.

8. Turn the bridge over. Remove the four screws which fasten the microcircuit assembly. Take out the microcircuit assembly. Note the stainless steel spacer under it.
9. Install the spacer over the screw holes and the bridge microcircuit assembly over the spacer. Reinstall the four microcircuit assembly screws.
10. Perform in reverse sequence steps 2 through 8.
11. Refer to Section 5, Adjustments, and perform them as required to match the microcircuit to the preamplifier and pass the performance tests.
12. Attach the new label to the bridge housing.

### Power Supply Check

1. Connect the power cord of the bridge (W1) to the analyzer and turn on the analyzer.
2. Refer to Figure 8-1 and check the power supply voltages of +15, -12.6, +8 and -5 volts at the 4 pads indicated. Since the +15V and -12.6V are supplied by the analyzer, those voltages are specified in the analyzer's manual. The +8V should be  $+8.3 \pm 0.3V$ ; -5V should be  $-5 \pm 0.2V$ .

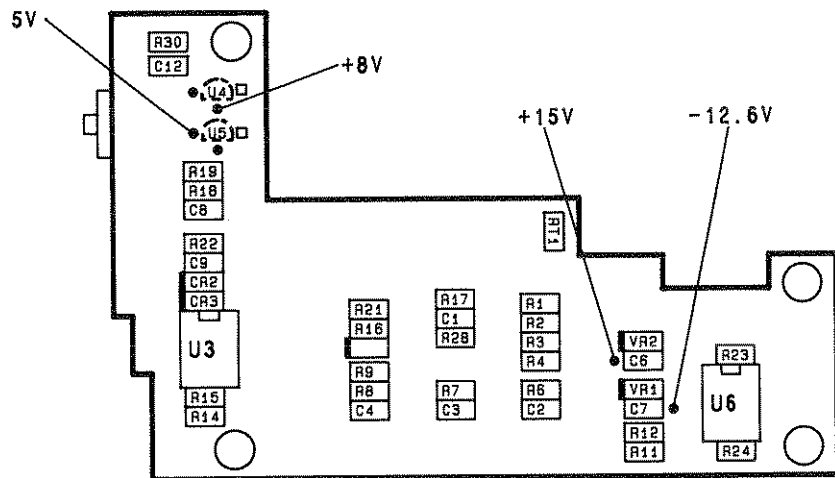

Figure 8-1. A2 Circuit Board Power Supply Check Points

3. Refer to Figure 8-1 and check the power supplies at the various components as indicated by malfunction.



### Signal Path Check

1. Check the output of the buffer amp at U6 pin 6. The voltage should be the same as that measured in step 3 of the microcircuit check. It may be offset.
2. Check the output of U1 pin 14 with the gain potentiometer (R5) centered. The voltage should be approximately  $0.44V_{\text{rms}}$ .

### Clock/Control Check

1. With the HP 85027 configuration switch set at [HP8756/HP8755], verify that there is no squarewave output at U2 pins 1, 2 and 4.
2. Set the HP 85027 configuration switch to the [HP8757] position.
3. Configure the HP 8757A for DC mode.
4. Verify a squarewave output of 27.778 kHz at U1 pin 14.
5. If U1 pin 14 does not have a squarewave output, check for a squarewave of 27.778 kHz at U1 pins 2 and 3, also U2 pins 1 and 2; 55.555 kHz at U1 pin 9, also U2 pin 4.

### CONNECTOR INSPECTION

Periodically inspect the connectors visually and mechanically. A bad connector can damage a good connector on the first connection. The effort and expense of replacing bridges with damaged connectors can be lessened by using good connectors. If a connector fails the visual or mechanical inspection or, in use doesn't feel right, don't use it.

#### Visual Inspection

Inspect connectors with an illuminated, 4-power magnifying glass. The lighting is crucial, the exact power is not. Normal room lighting, especially oblique desk lamp lighting, casts shadows. The shadows can mask the small defects you are trying to expose. Magnifying glasses with integral lighting provide shadowless, axial illumination. They are readily available from general equipment suppliers. Get one and use it.

Examine connectors for obvious problems such as deformed or clogged threads, contamination or corrosion. Concentrate on the contact surfaces. Look for burrs, scratches, rounded shoulders or other signs of wear or damage. Defects which you can see with the magnifying glass can degrade performance. Replace defective connectors.

If a connector is dirty, clean it. Work static free. Refer to Figure 8-3 for cleaning suggestions. Note that those suggestions apply equally to 3.5mm and Type-N connectors. Try blowing off the dirt with compressed air first. Brush or wipe any remaining dirt from the surface carefully. Use trichlorotrifluoroethane (liquid Freon) sparingly as a cleaning solvent if need be. Do not use abrasives or other solvents which could damage the thin metal plating or the plastic dielectric supporting element.



**NOTE**

TRY TO CLEAN THE CONNECTOR WITH COMPRESSED AIR BEFORE RESORTING TO SWABS.

WRAP THIN FOAM OR A LINT-FREE CLOTH AROUND A SLENDER WOODEN ROD (SUCH AS A TOOTHPICK) FOR CLEANING AREAS THAT ARE TOO SMALL FOR THE SWABS.

**WRONG**

CIRCULAR STROKES LEAVE TORN FIBERS SNAGGED ON EDGES OF CENTER COLLET.

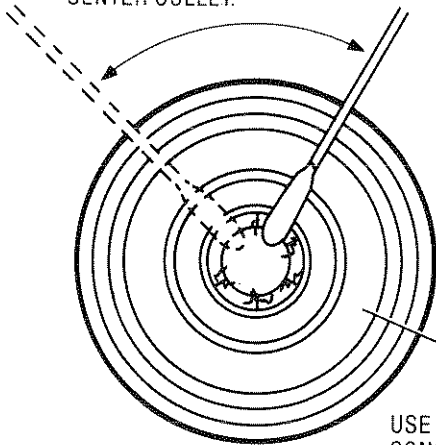

**CORRECT**

RADIAL STROKES DO NOT LEAVE TORN FIBERS.

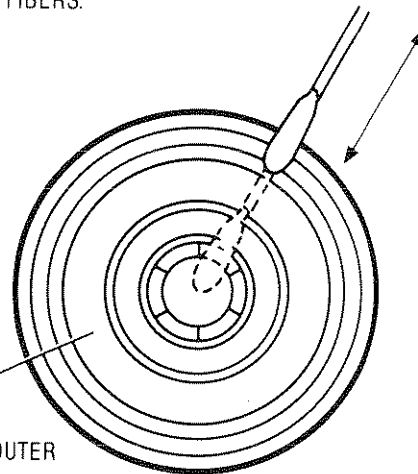

USE CIRCULAR STROKES FOR OUTER CONDUCTOR FACE **ONLY**.

Figure 8-3. Cleaning APC-7 Connectors

## Mechanical Inspection

**Gaging the Precision 3.5mm Connector:** Use a precision 3.5mm connector gage to check the mechanical dimensions of the connector. The tolerances are tight, but must be met to ensure perfect mating between the connector surfaces. Perfect mating both ensures a good electrical match and reduces the possibility of connector damage.

The recession of the center conductor is the critical dimension. The maximum allowable recession of the center conductor is 0.003 in. (0.08mm). The minimum allowable recession of the center conductor is 0.00 in. Any center conductor which protrudes beyond the outer conductor mating plane is out of tolerance. It will permanently damage any connector attached to it by buckling the female contact fingers. This damage and the resultant electrical interference is often noticeable as a power hole of several dB at about 22 GHz.

Any center conductor which is recessed too far (>0.003 in.) behind the outer conductor mating plane will cause poor electrical contact and high reflections.

Before using the connector gage to measure the connector, visually inspect the end of the gage and the calibration block. Dirty or damaged gage facings can cause dirty or damaged connectors. Refer to Figures 8-5 and 8-6 to see how to use and zero the gage. Refer to Figure 8-7 to see how to measure precision 3.5mm connectors. Note that a plus (+) reading on the gage indicates a recession. Thus center conductor readings must be between +0.000 and +0.003 in.

If you will be mating precision 3.5mm connectors with SMA connectors, please refer to Figure 8-4, SMA and precision 3.5mm connectors.

**CAUTION: SMA CONNECTORS**

SMA connectors will mate with precision 3.5mm connectors. But use caution to prevent accidental damage due to worn or out-of-specification connectors. Such connectors can destroy a precision 3.5mm connector *even on the very first connection*. Hewlett-Packard recommends that you keep two points in mind when you mate SMA with 3.5mm connectors.

(1) SMA connectors are not precision mechanical devices. They are very susceptible to mechanical wear and are often found to be out of specification prior to first use. Thus gaging SMA connectors is the single most important step you can take to prevent damaging your equipment. It takes very little time as shown in Section 8.

Also take care with initial alignment: push the two connectors straight together without overtightening or rotating either center conductor. Use a torque wrench (HP part number 8710-1582) for the final connection. This torque (5 lb-in, 60 N-cm) is less than is used when mating 3.5mm connectors together. Use connector-savers for an extra margin of safety.

(2) Important structural and dimensional differences exist between these two types of connectors. Thus when an SMA connector is mated to a precision 3.5mm connector, the connection will typically exhibit a discontinuity match at about 20 GHz. This mismatch is less than when two SMA connectors are mated together although it is higher than when precision 3.5mm connectors are mated together.

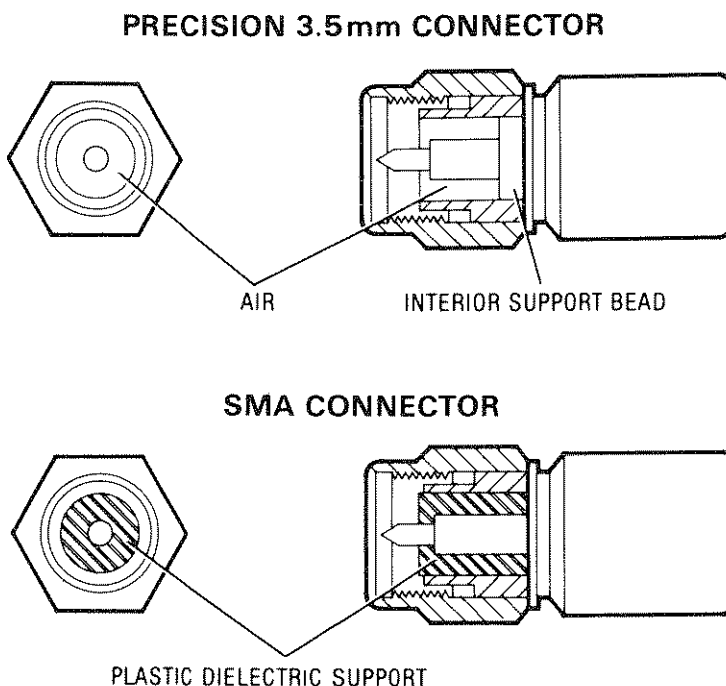

Figure 8-4. SMA and Precision 3.5mm Connectors



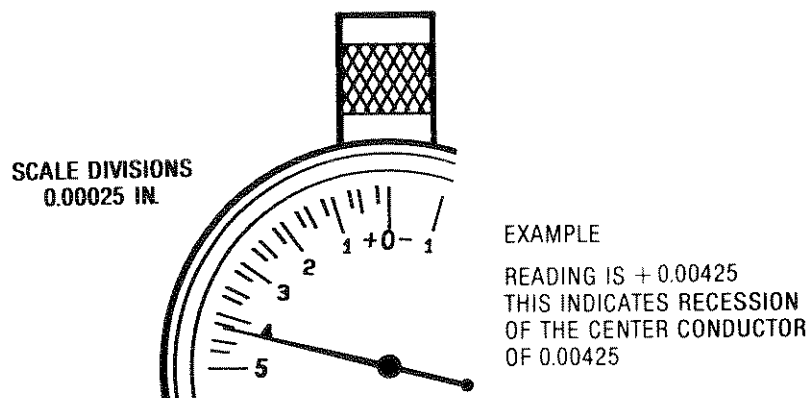
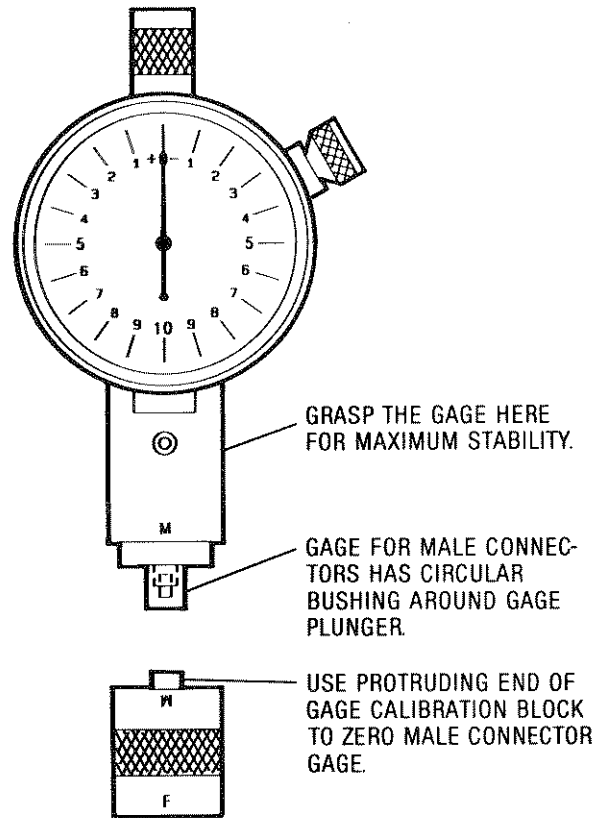

Figure 8-5. Precision 3.5mm (m) Connector Gauge

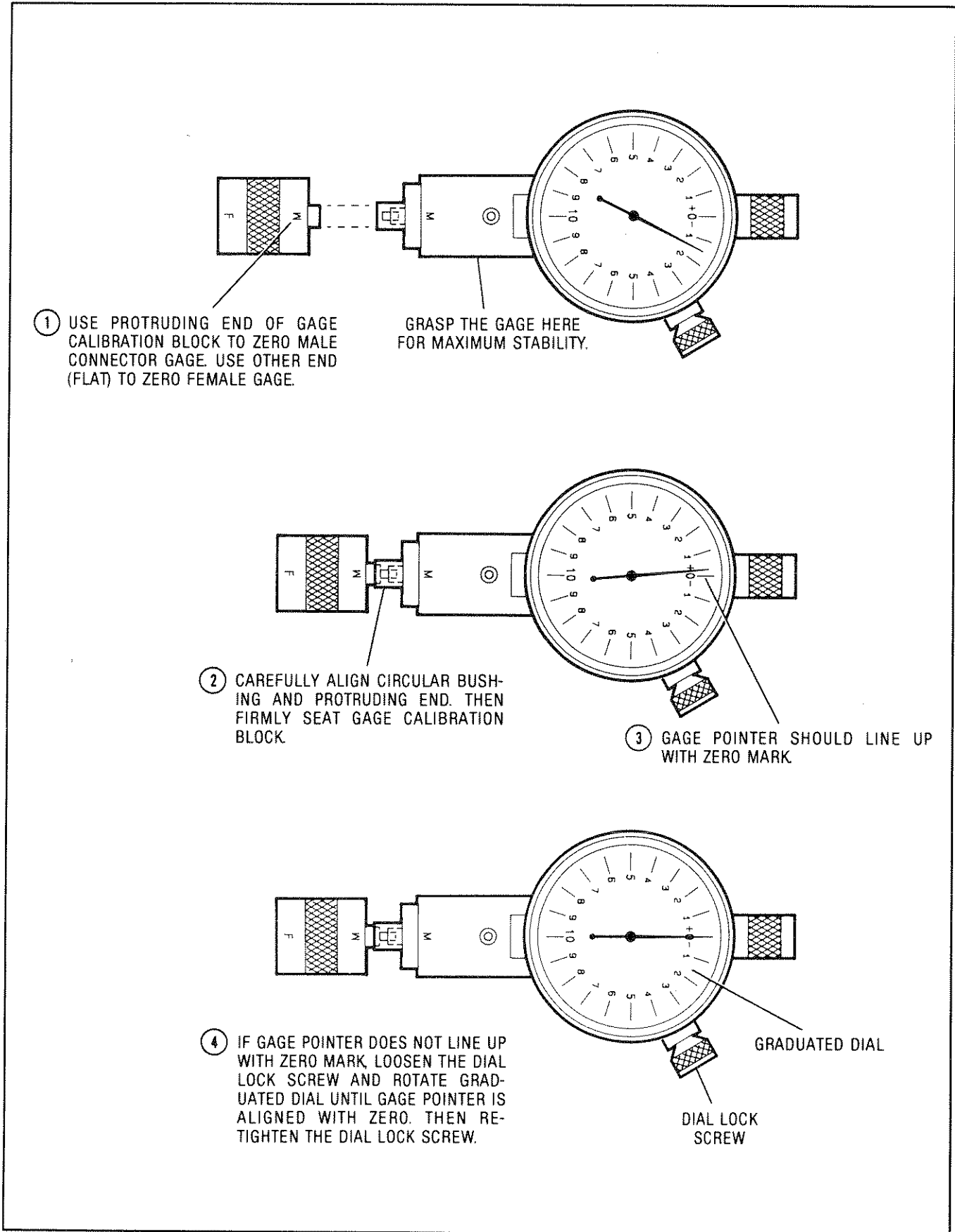

Figure 8-6. Zeroing Precision 3.5mm (m) Connector Gage

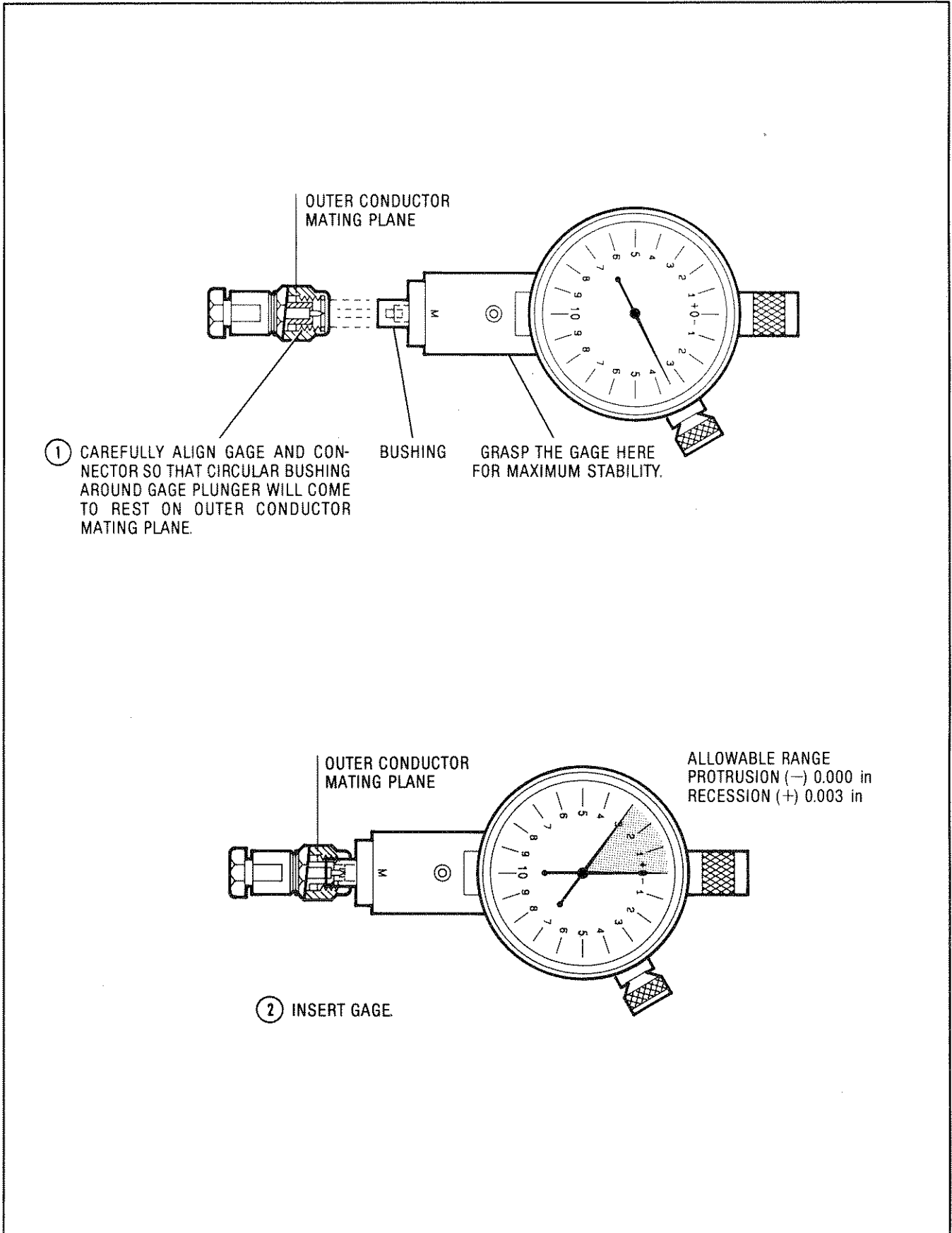

Figure 8-7. Gaging Precision 3.5mm (m) Connector

**Gaging the APC-7 Connector:** APC-7 connectors have 3 parts which determine the 2 critical dimensions in terms of mating surfaces. Figure 8-10 shows these parts and their critical dimensions. The outer conductor may be recessed or protruding from the extreme end of the connector coupling sleeve. That amount of recession or protrusion is not critical because the important dimensions are relative to the plane of the outer conductor itself. The center conductor is a very thin tube which holds the center collet. The center conductor must recede from the plane of the outer conductor. The center conductor is rigid and serves only to hold the center collet in place. It is the center collet which must protrude to make contact. Note that the center collet is spring loaded and thus can retract without damage when mated.

Refer to Figures 8-8, 8-9 and 8-10 to see how to read and zero the APC-7 gage and how to use it to gage APC-7 connectors.

If the center collet is damaged, and the other parts of the connector are neither damaged nor excessively worn, you can replace the collet. Refer to Figure 8-11 for instructions.

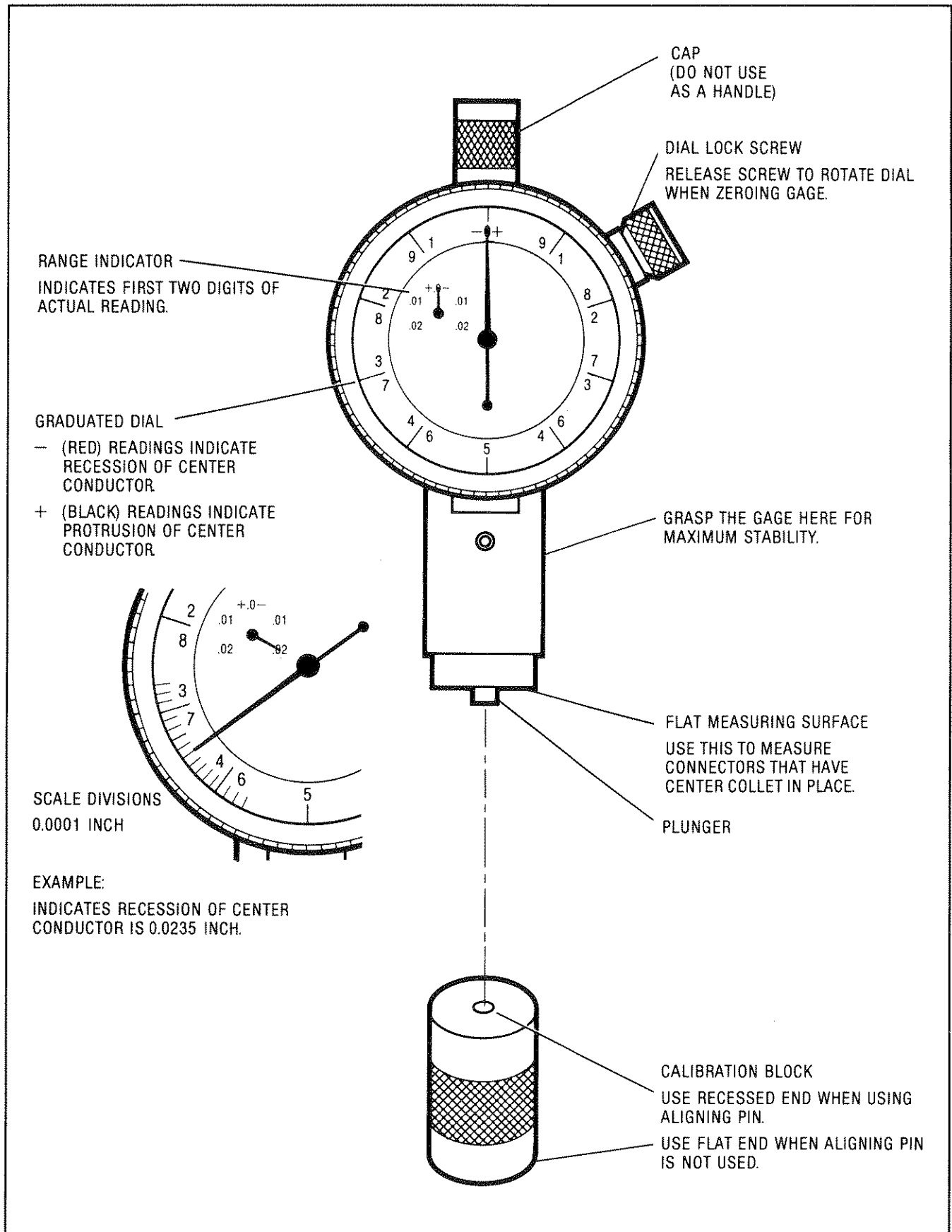

Figure 8-8. The APC-7 Connector Gage

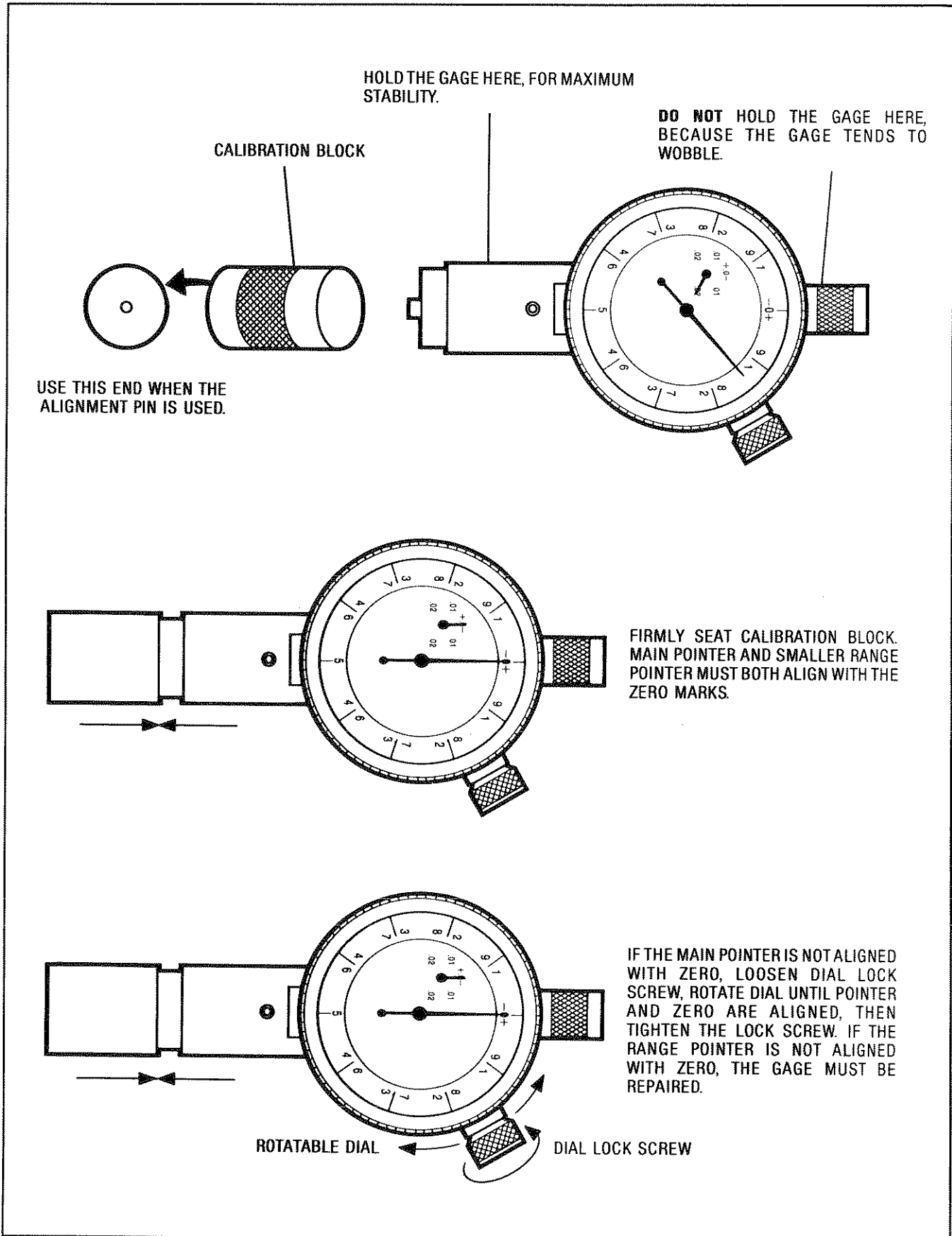

Figure 8-9. Zeroing the APC-7 Gage

**ALLOWABLE RANGE (ALL CONNECTORS):** +0.002 INCH TO +0.010 INCH

CENTER COLLET **MUST** PROTRUDE BEYOND PLANE OF OUTER CONDUCTOR 0.002 – 0.010 INCH (0.05 – 0.25mm).

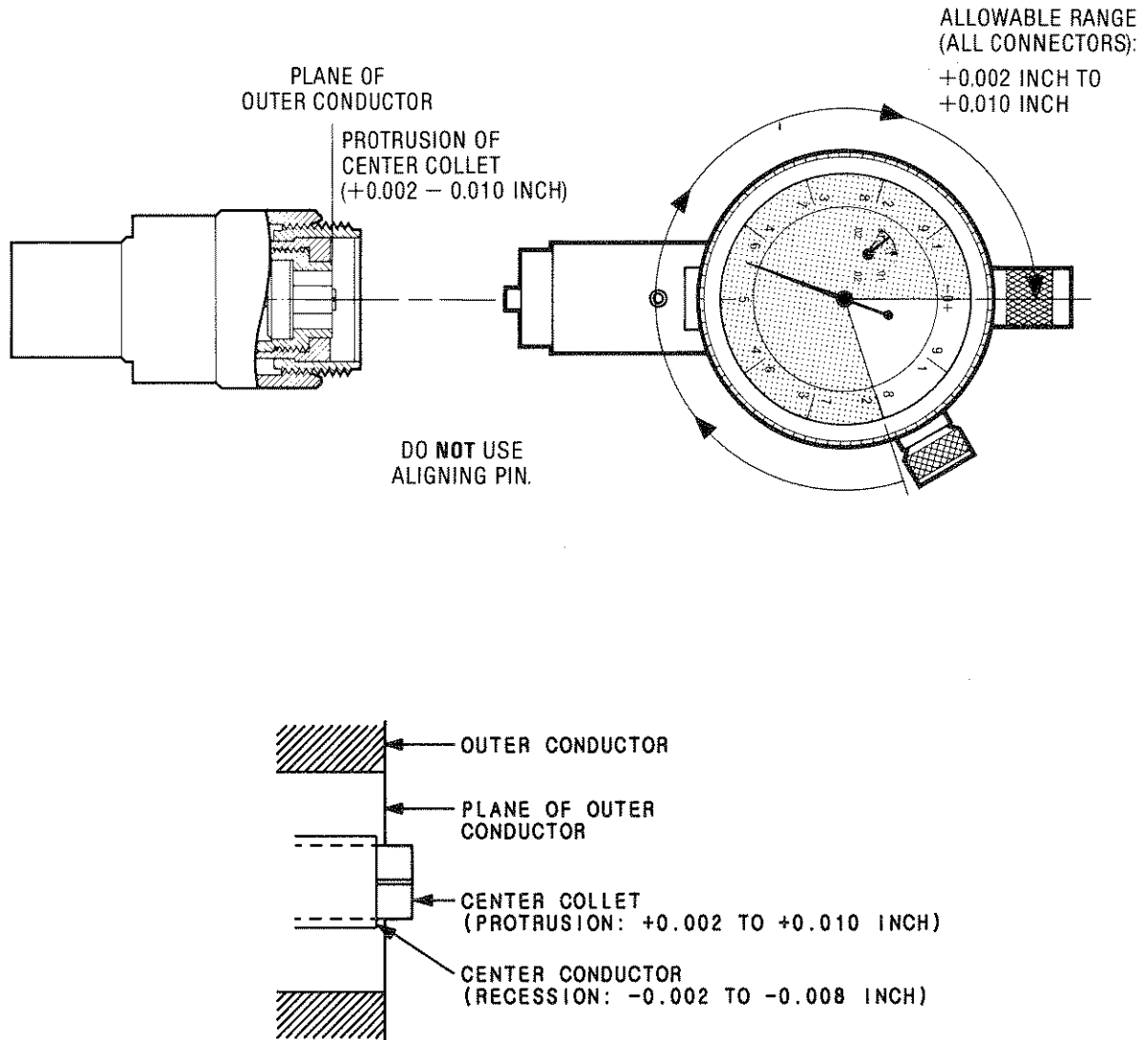
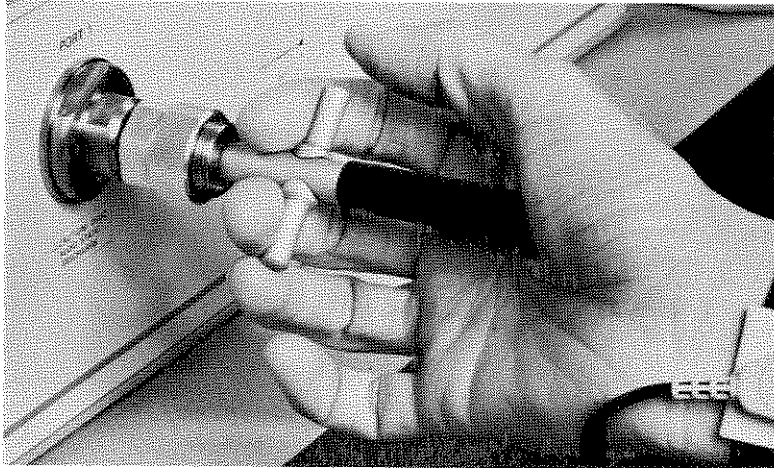
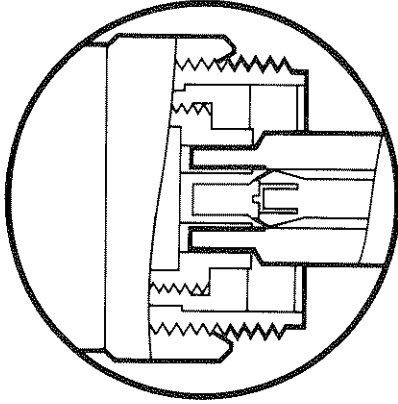

Figure 8-10. Gaging APC-7 Connectors

**REMOVING OLD COLLET.**



**REPLACING OLD COLLET, OR INSERTING NEW COLLET.**

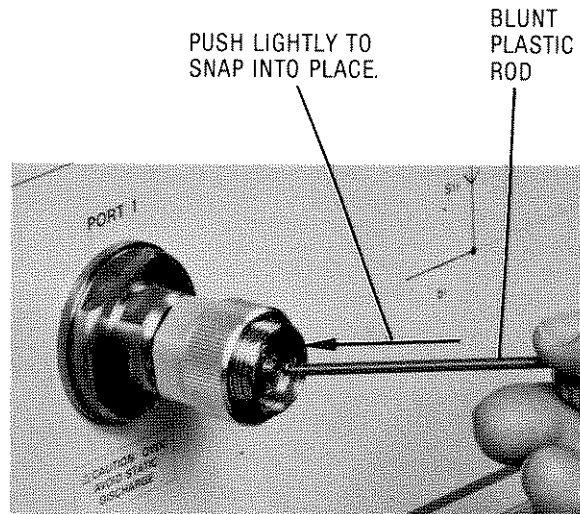
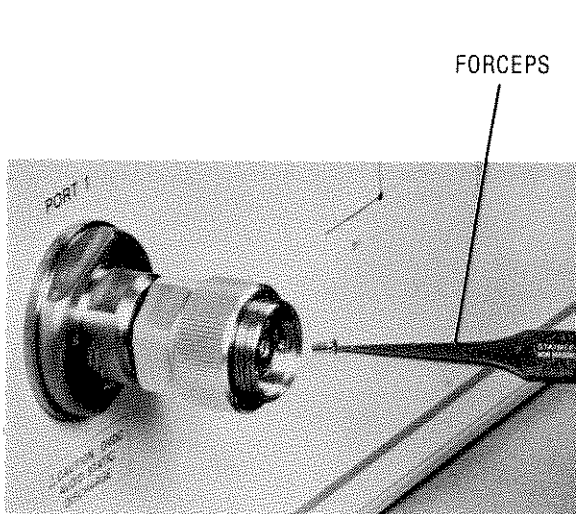

Figure 8-11. Collet Removal and Replacement, APC-7 Connectors