

# 85020 A/B DIRECTIONAL BRIDGE

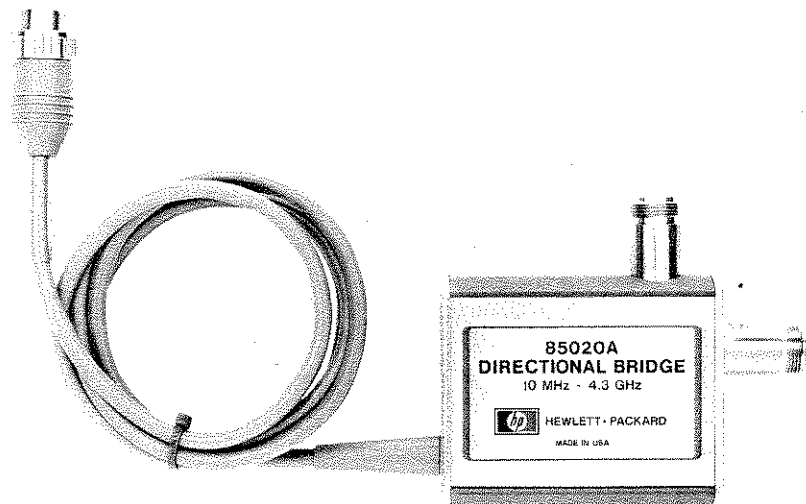

**HEWLETT  
PACKARD**



# 85020A/B DIRECTIONAL BRIDGE

## SERIAL NUMBERS

This manual applies directly to the HP Model 85020A/B Directional Bridge with serial numbers prefixed as follows:

Model	Serial Prefix
85020A	2301A
85020B	2308A

For additional information about serial numbers, refer to INSTRUMENTS COVERED BY MANUAL in Section I.

© Copyright HEWLETT-PACKARD COMPANY 1983  
1400 FOUNTAIN GROVE PARKWAY, SANTA ROSA, CA 95401, U.S.A.

Manual Part No. 85020-90001  
Microfiche Part No. 85020-90002

Printed: JUNE 1983





*Figure 1-1. Model 85020A Directional Bridge in Accessory Case Supplied*

**CAUTION**

The 85020A/B Directional Bridges contain microcircuits that are highly sensitive to electrostatic discharge (ESD). Damage from ESD is most likely to occur as the bridges are connected or disconnected. The surest method of protecting the 85020A/B is for the operator to wear a grounding strap that provides a path to ground of no less than 1 Megohm and no more than 2.5 Megohms. Alternatively the operator can ground himself before touching the bridge connectors, by touching any grounded instrument chassis. Never touch the center contacts of the connectors.

Tests at Hewlett-Packard have revealed that repeated ESD charges as low as 250 volts can destroy microwave diodes. Ordinary activities around everyday materials can generate ESD voltages of tens of thousands of volts. Materials conducive to static build-up include floor carpeting, nylon clothing, dry air, paper, adhesive tape, styrofoam, and vinyl. Use of the precautions described here will considerably reduce the probability of damage from ESD.

For service purposes, a work station equipped with an anti-static surface must be used. Use only anti-static solder removers and grounded soldering irons. Some replacement parts may be shipped in static-protective packaging; remove the parts from this packaging only at an anti-static work station while wearing the grounded wrist strap. All anti-static safeguards should conform to state and federal safety standards.

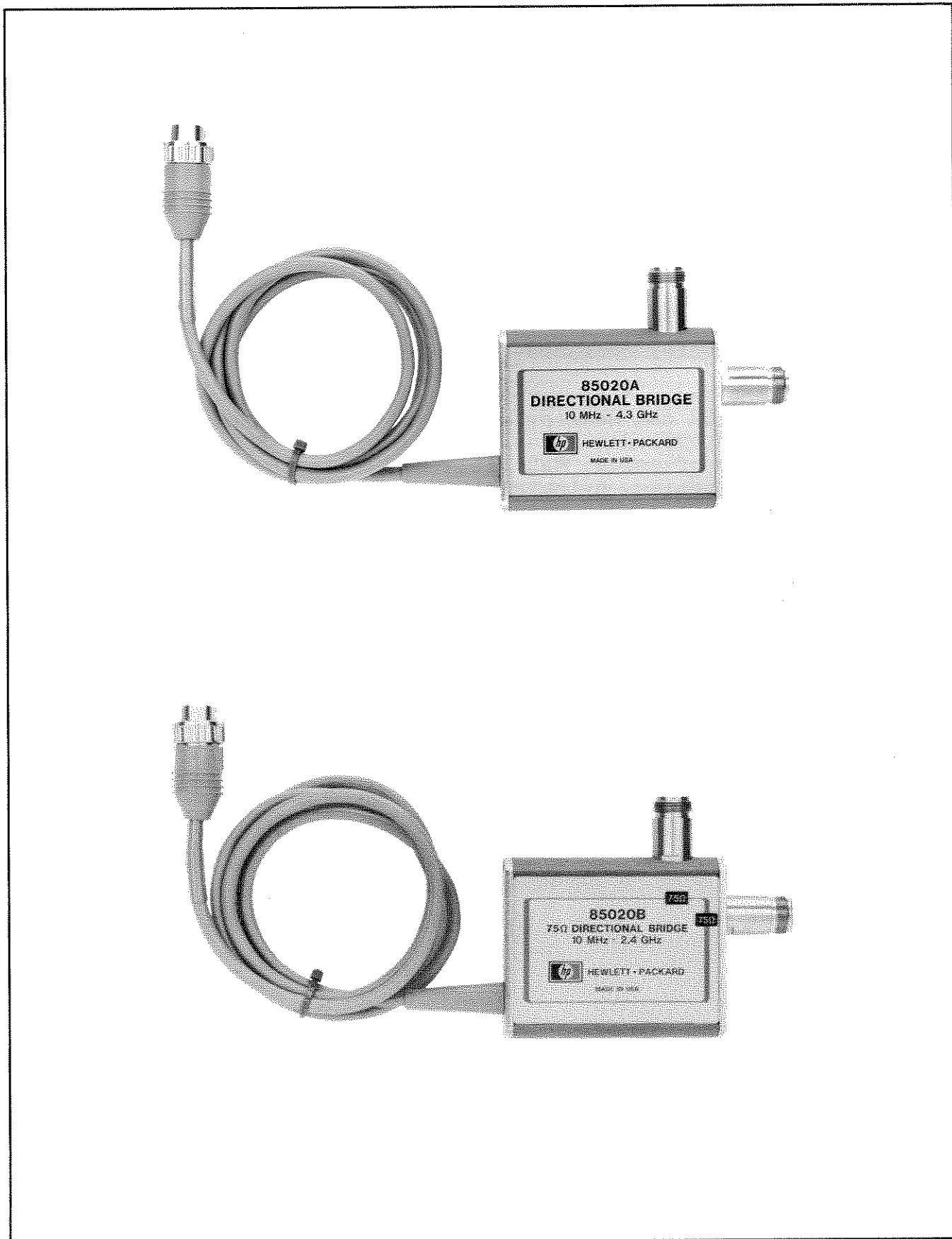

Figure 1-2. Models 85020A and 85020B Directional Bridges

**SECTION I****GENERAL INFORMATION****1-1. INTRODUCTION**

1-2. This manual contains operating and service information for the Hewlett-Packard Models 85020A and 85020B Directional Bridges. Section I includes specifications and supplemental performance characteristics, safety considerations, instrument identification, description, and other basic information. Figure 1-1 shows the Model 85020A in the accessory instrument case supplied with each instrument. Figure 1-2 shows both the 85020A and the 85020B Directional Bridges.

1-3. On the title page of this manual is a microfiche part number. This number may be used to order 10- by 15-centimeter (4- by 6-inch) microfilm transparencies of the manual. Each microfiche contains up to 60 photo duplicates of the manual pages. The microfiche package also includes the latest Manual Changes supplement as well as all pertinent Service Notes.

1-4. Refer any questions regarding this manual, the Manual Changes supplement, or the instrument to the nearest HP Sales/Service Office. Always identify the instrument by model number, complete name, and complete serial number in all correspondence. Refer to the inside rear cover of this manual for a worldwide listing of HP Sales/Service Offices.

**1-5. SPECIFICATIONS**

1-6. Specifications for the 85020A/B are listed in Table 1-1. These specifications are performance standards or limits against which the instrument may be tested. Table 1-2 lists supplemental characteristics. These are not specifications but are intended to provide information useful in applying the instrument by giving typical but non-warranted performance parameters.

**1-7. SAFETY CONSIDERATIONS**

1-8. The voltages present in the 85020A/B are not in a range to warrant more than normal caution.

**CAUTION**

The CAUTION sign in this manual calls attention to an operating procedure or practice which, if not correctly performed or adhered to, could damage or destroy the equipment. Do not proceed beyond a CAUTION sign until the indicated conditions are fully understood and met.

**1-9. INSTRUMENTS COVERED BY MANUAL**

1-10. This instrument has a two-part serial number. The first four digits and the letter comprise the serial number prefix. The last five digits form the sequential suffix that is unique to each instrument. The contents of this manual apply directly to instruments with a serial number prefix given on the title page under the heading SERIAL NUMBERS.

1-11. An instrument manufactured after the printing of this manual may have a serial prefix that is not shown on the title page. This unlisted serial prefix indicates that the instrument is different from those documented in this manual. The manual for such an instrument will be supplied with a yellow Manual Changes supplement containing information to document the differences.

1-12. In addition to change information, the supplement may contain information for correcting errors in the manual. To keep this manual as current and accurate as possible, Hewlett-Packard recommends that you periodically request the latest Manual Changes supplement. The supplement for this manual is keyed to the manual's print date and part number, both of which appear on the title page. Complimentary copies of the supplement are available from Hewlett-Packard.

**1-13. DESCRIPTION**

1-14. The 85020A and 85020B are Directional Bridges designed to be used in conjunction with the Hewlett-Packard Model 8756A and 8755C Scalar Network Analyzers for making scalar reflection and transmission measurements. A single zero-biased Schottky diode detector in the bridge samples the return loss of a device under test for reflection measurements. Transmission measurements can be made with the addition of a detector. A power splitter can be used with the bridge for ratio measurements. A swept RF input signal is supplied by a sweep oscillator or a synthesized sweeper.

1-15. The 85020A is a 50-ohm bridge with a frequency range of 10 MHz to 4.3 GHz. Both the input connector and the test port



connector are type-N (female). The 85020B is a 75-ohm bridge with a frequency range of 10 MHz to 2.4 GHz. The connectors are both type-N (female).

#### **1-16. EQUIPMENT SUPPLIED**

1-17. The 85020A and 85020B Directional Bridges are each supplied in an instrument case as illustrated in Figure 1-1.

#### **1-18. EQUIPMENT REQUIRED BUT NOT SUPPLIED**

1-19. The following equipment is required for use with the 85020A/B in making transmission and reflection measurements:

- HP Model 8756A or 8755C Scalar Network Analyzer.
- HP Model 8350A/B Sweep Oscillator or 8340A Synthesized Sweeper.
- HP Model 11664A detector (0.01 to 18 GHz).
- HP Model 85023C/D System Verification Kit (see Table 1-3).

#### **1-20. Scalar Network Analyzer**

1-21. The Model 8756A Scalar Network Analyzer is a microprocessor based dual-channel receiver with its own digital display. It makes scalar transmission and reflection measurements at RF and microwave frequencies, over a dynamic range of -50 dBm to +10 dBm. It can measure amplitude ratios up to 60 dB. The 8756A is completely programmable through HP-IB (Hewlett-Packard Interface Bus), and can control a plotter (HP 7470A or 9872C) or a swept source (HP 8350B or 8340A) through the 8756 System Interface. HP-IB is Hewlett-Packard's hardware, software, documentation, and support for IEEE-488 and IEC-625, worldwide standards for interfacing instruments. The 85020A/B Directional Bridges are designed to be used with the 8756A.

1-22. The 85020A/B Directional Bridges are also fully compatible with the Model 8755C Scalar Network Analyzer. Although the 8755C is not programmable, it also measures amplitude levels of -50 dBm to +10 dBm and amplitude ratios of 60 dB over a frequency range determined by the detectors used. The 8755C plugs into a Model 180-series display mainframe such as the 182T or the 180TR. In applications where memory or normalization is required, the 8750A Storage Normalizer is used in conjunction with the 8755C. In this case, the display mainframe used with the 8755C may require modification for interface with the 8750A. A table of 8750A/Display Mainframe compatibility is provided in Section I of the 8755C Operating and Service Manual.

1-23. Both the 8756A and the 8755C use an AC detection technique with an operating frequency of 27.8 kHz. This technique provides nearly drift-free operation. An RF or microwave source signal is modulated at 27.8 kHz and is input to the Scalar Network Analyzer through one or more detector inputs. The detectors demodulate this signal to produce a 27.8 kHz square wave whose peak-to-peak voltage corresponds to the magnitude of the signal at the detector input. Since only the 27.8 kHz modulated signal is detected, unmodulated broadband noise and extraneous signals are eliminated from the measurement.

#### 1-24. Swept Signal Source

1-25. A complete system for making transmission and reflection measurements requires a swept signal source to supply an RF input signal. The Model 8350B Sweep Oscillator with an RF Plug-In installed is an 8756A-compatible solid-state swept signal source with a frequency range determined by the RF Plug-In. For example, the Model 83525A/B RF Plug-In covers a frequency range of 0.01 to 8.4 GHz; and the Model 83522A has the same frequency range as the 85020B (0.01 to 2.4 GHz). The 8350B is fully HP-IB programmable, and can be controlled by the 8756A through the 8756 System Interface. It has internal 27.8 kHz squarewave modulation capability.

1-26. The Model 8350A Sweep Oscillator is similar to the 8350B, and is compatible with the 8756A. However, it does not have the firmware to enable 8756A control through the 8756 System Interface. Retrofit kits are available from Hewlett-Packard to update the 8350A for interface performance comparable to the 8350B.

1-27. The Model 8340A Synthesized Sweeper is an analog sweep synthesizer that generates synthesized output frequencies from 0.01 to 26.5 GHz. It is a complete swept signal source requiring no additional equipment. The 8340A is fully HP-IB programmable, and can be controlled by the 8756A through the 8756 System Interface. The 8340A can be squarewave modulated at 27.8 kHz with the Modulator Drive signal from the 8756A or 8755C Network Analyzer.

#### 1-28. Detectors

1-29. One or more Model 11664A detectors are used with the 8756A or the 8755C and the 85020A/B Directional Bridges for making RF transmission measurements. The 27.8 kHz modulated signal from the device under test is applied to the 11664A detector(s) on the Scalar Network Analyzer inputs. The 11664A demodulates this signal to produce a 27.8 kHz square wave whose peak-to-peak voltage corresponds to the magnitude of the signal at the detector input.

Each detector uses a biased Schottky diode to achieve -50 dBm sensitivity. The frequency range of the 11664A is 0.01 to 18 GHz.

#### **1-30. Power Splitter**

1-31. Ratio measurements can be obtained using a power splitter in conjunction with the scalar network analyzer and detector(s). The HP Model 11667A power splitter has a frequency range of DC to 18 GHz.

#### **1-32. EQUIPMENT AVAILABLE**

1-33. Additional equipment available for use with the 8756A Scalar Network Analyzer and the 85020A/B Directional Bridges is listed in Section I of the 8756A Operating and Service Manual.

#### **1-34. ACCESSORIES AVAILABLE**

1-35. Table 1-3 lists 85023-series System Verification Sets available for use with the 85020A/B and the 8756A. These accessory sets are supplied in a 50-ohm version and a 75-ohm version to correspond with the impedance of the bridges. Each set contains a high quality adapter, a standard short circuit, a matched termination, and a 50-ohm 10-dB pad. In addition, the 50-ohm version includes a standard open circuit; and the 75-ohm version includes a 50-ohm to 75-ohm minimum-loss pad.

#### **1-36. RECOMMENDED TEST EQUIPMENT**

1-37. Table 1-4 lists recommended test equipment. This equipment is used in performance testing of the 85020A/B. Other equipment may be substituted, provided its specifications equal or exceed the specifications given in the Critical Specifications column.

#### **1-38. WARRANTY**

1-39. Any attempt to perform any disassembly or repair procedure not clearly outlined in Section VIII, Service, of this manual will automatically void the warranty.

1-40. Subjection of the instrument to RF input power levels in excess of +23 dBm will automatically void the warranty.

Table 1-1. Specifications

	85020A	85020B
<b>Frequency Range (GHz):</b> <sup>1</sup>	0.01 to 4.3	0.01 to 2.4
<b>Input Connector:</b>	Type-N (f) 50 ohms	Type-N (f) 75 ohms
<b>Output Connector:</b>	Type-N (f) 50 ohms	Type-N (f) 75 ohms
<b>Maximum Power to Input Port:</b>	+23 dBm	+23 dBm
<b>Directivity:</b> <sup>2</sup> 0.01 to 2.4 GHz 2.4 to 3.0 GHz 3.0 to 4.3 GHz	>40 dB ≥40 dB ≥34 dB	≥40 dB - -
<b>Test Port Match (SWR):</b> 0.01 to 1.3 GHz 1.3 to 2.4 GHz 2.4 to 3.0 GHz 3.0 to 4.3 GHz	<1.20 ≤1.20 ≤1.20 ≤1.25	<1.25 ≤1.39 - -
<b>Dimensions:</b>	25 mm high x 110 mm wide x 96 mm deep (1.0 in x 4.3 in x 3.9 in) cable length: 1219 mm (48 inches)	
<b>Weight:</b>	Net: 0.5 kg (1.2 lb) Shipping: 2.3 kg (5 lb)	

<sup>1</sup>Unless otherwise noted, all specifications are at 0°C to 55°C.

<sup>2</sup>25°C ± 5°C.

Table 1-2. Supplemental Characteristics

Values in this table are not specifications, but are typical but non-warranted performance parameters included for user information.

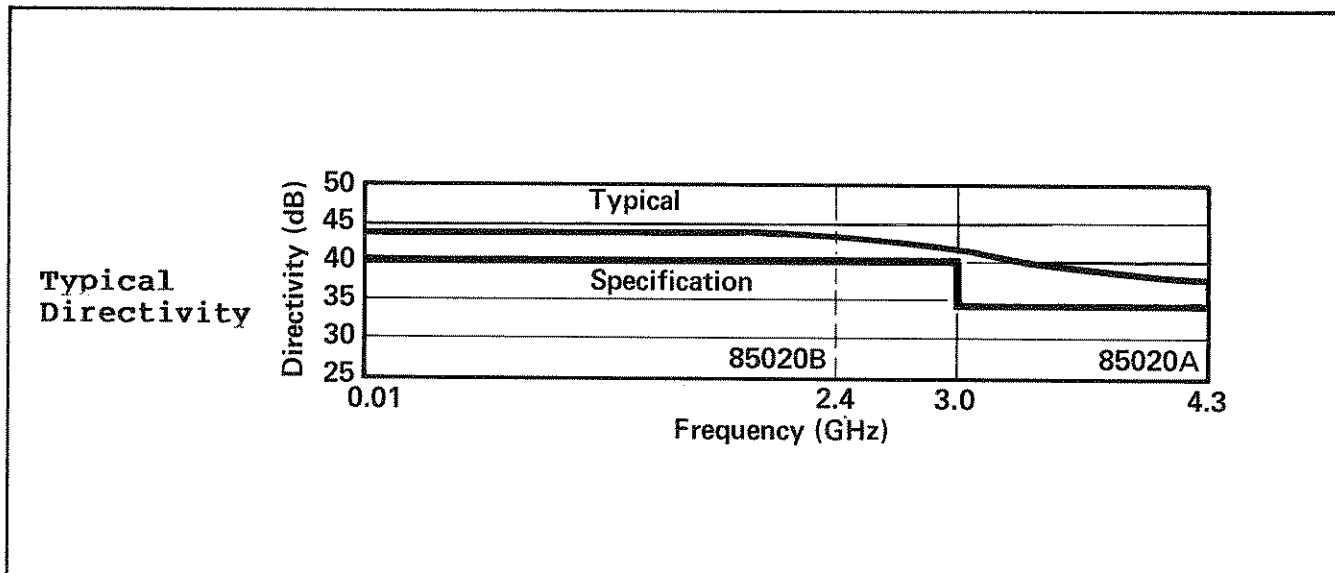

	85020A	85020B
<b>Typical Input Port Match (SWR):</b> 0.01 to 2.4 GHz 2.4 to 4.3 GHz	<1.2 <1.2	<1.2 -
<b>Typical Insertion Loss:</b>	6.5 dB	6.5 dB
<b>Typical Detector Flatness</b> (Referenced to 1 GHz):	+0.5 dB	+0.5 dB
<b>Minimum Input Power</b> for 40 dB Return Loss Measurement:	+4 dBm	+4 dBm
<b>Nominal Impedance:</b>	50 ohms	75 ohms

Table 1-3. System Verification Sets

<b>HP Model 85023C (Type-N, 50 Ohms)</b> <b>(For Use with Model 85020A Directional Bridge)</b>		
<b>Qty</b>	<b>Accessory</b>	<b>HP Part or Model Number</b>
1	Type-N short	11512A
1	Type-N open	85032-60001
1	Type-N(m) to type-N(m) adapter	1250-1475
1	Type-N 50-ohm termination	909A Opt. 012
1	Type-N 10 dB pad	8491B Opt. 010
1	instrument case	
1	Operating Note	
<b>HP Model 85023D (Type-N, 75 Ohms)</b> <b>(For Use with Model 85020B Directional Bridge)</b>		
<b>Qty</b>	<b>Accessory</b>	<b>HP Part or Model Number</b>
1	75-ohm type-N short	1250-1530
1	Type-N(m) to type-N(m) adapter	1250-1475
2	50-ohm to 75-ohm minimum loss pad	11852A
1	Type-N 75-ohm termination	1250-1532
1	50-ohm type-N 10 dB pad	8491B Opt. 010
1	instrument case	
1	Operating Note	

Table 1-4. Recommended Test Equipment

		85020A	85020B
Instrument	Critical Specifications	Recommended Test Model	
Scalar Network Analyzer	Operating Frequency: 27.8 kHz 85020A/B compatible Includes display	8756A or 8755C/ 182T	8756A or 8755C/ 182T
Sweep Oscillator plus RF Plug-In  or Synthesized Sweeper	8756A compatible  Frequency: 0.01-2.4 GHz  Frequency: 0.01-4.3 GHz  Frequency: 0.01-4.3 GHz	8350A/B  83525A/B  8340A	8350A/B  83522A or 83525A/B  8340A
Detectors (2)	Frequency: 0.01-4.3 GHz	11664A	11664A
System Verification Set (Table 1-3)	Type-N, 50 ohms Type-N, 75 ohms (includes 75-ohm matching pad)	85023C	85023D
Step Attenuator	Frequency: DC-4.0 GHz 0-70 dB in 10-dB steps	8495A Opt. 001	8495A Opt. 001
Digital Multimeter	Accuracy: +0.01% Input Impedance: $\geq 10M$ Ohms	3456A	3456A
Storage Normalizer	For use with 8755C where memory is required	8750A	8750A

This equipment is used for performance testing, adjustment, and troubleshooting.





## SECTION II

### INSTALLATION

#### 2-1. INTRODUCTION

2-2. This section provides information about initial inspection, preparation for use, mating connectors, packaging, storage, and shipment.

#### 2-3. INITIAL INSPECTION

2-4. Inspect the shipping container for damage. If the shipping container or cushioning material is damaged, it should be kept until the contents of the shipment have been checked for completeness and the instrument has been checked mechanically and electrically. The contents of the shipment should be as shown in Figure 1-1. Procedures for checking electrical performance are given in Section IV, Performance Tests, of this Operating and Service Manual. If the instrument does not pass the electrical Performance Tests, and a circuit malfunction is suspected, refer to Troubleshooting Procedures in Section VIII, Service, in this manual. If the instrument does not pass the above electrical tests, if the shipment contents are incomplete, or if there is mechanical damage or defect, notify the carrier as well as the nearest Hewlett-Packard Office. Keep the shipping materials for the carrier's inspection. The HP Office will arrange for repair or replacement without waiting for claim settlement.

#### 2-5. PREPARATION FOR USE

#### 2-6. Power Requirements

2-7. Power for the Model 85020A/B Directional Bridge is obtained from the Model 8756A or 8755C Scalar Network Analyzer.

#### 2-8. Connecting the 85020A/B Directional Bridge

2-9. To connect the 85020A/B for operation with the 8756A or 8755C Scalar Network Analyzer and the 8350A/B Sweep Oscillator, proceed as follows:

1. Secure the connector of the power cable W1 into the A, R, or B mating connector of the Network Analyzer by turning the outer shell clockwise to tighten.
2. Connect the RF output of the Sweep Oscillator RF Plug-In to the input port of the 85020A/B.

**CAUTION**

Do not apply more than +23 dBm RF power or more than +10 volts DC into the 85020A/B. If more than this power or voltage is applied, the Bridge will be damaged.

3. The device under test is connected to the Bridge test port. Typical measurement configurations are shown in Section III.

**2-10. Mating Connectors**

2-11. The mating connectors for the precision type-N connectors of the 85020A/B are the corresponding precision type-N connectors whose dimensions conform to US specification MIL-C-39012.

2-12. To extend the life of the connectors, it is recommended that a precision adapter be used on the test port in any application where some degradation of directivity can be accepted. Refer to Section III, Operation, for more information on connector wear.

**2-13. Operating Environment**

2-14. **Temperature.** The instrument may be operated in temperatures from 0°C to +55°C.

2-15. **Humidity.** The instrument may be operated in environments with humidity from 5% to 80% relative at +25°C to +40°C. However, the instrument should also be protected from temperature extremes which cause condensation within the instrument.

2-16. **Altitude.** The instrument may be operated at altitudes up to 4572 meters (15,000 feet).

**2-17. STORAGE AND SHIPMENT**

**2-18. Environment**

2-19. The instrument may be stored or shipped in environments within the following limits:

Temperature	. . . . .	-40°C to +75°C
Humidity	. . . . .	5% to 95% relative at 0° to +40°C
Altitude	. . . . .	Up to 15240 meters (50,000 feet)

2-20. The instrument should also be protected from temperature extremes which may cause condensation in the instrument.

**2-21. Packaging**

**2-22. Original Packaging.** Containers and materials identical to those used in factory packaging are available through Hewlett-Packard offices. If the instrument is being returned to Hewlett-Packard for servicing, attach a tag indicating the type of service required, return address, model number, and full serial number (located on the rear panel serial label). Mark the container FRAGILE to ensure careful handling. In any correspondence, refer to the instrument by model number and full serial number.

**2-23. Other Packaging.** The following general instructions should be used for repackaging with commercially available packaging materials:

- a. Wrap the instrument in anti-static plastic packaging material. If shipping to a Hewlett-Packard Office or Service Center, attach a tag indicating the type of service required, return address, model number, and full serial number.
- b. Use a strong shipping container.
- c. Use enough shock-absorbing material around all sides of the instrument to provide a firm cushion and to prevent movement inside the container.
- d. Seal the shipping container securely.
- e. Mark the shipping container FRAGILE to ensure careful handling.
- f. In any correspondence, refer to the instrument by model number and full serial number.



**SECTION III****OPERATION****3-1. INTRODUCTION**

3-2. This section contains information for operation of the 85020A/B Directional Bridges.

**3-3. OPERATING PRECAUTIONS****CAUTION****SUSCEPTIBLE TO DAMAGE  
FROM STATIC DISCHARGE**

The 85020A/B Directional Bridges contain microcircuits that are highly sensitive to electrostatic discharge (ESD). Damage from ESD is most likely to occur as the bridges are connected or disconnected. The surest method of protecting the 85020A/B is for the operator to wear a grounding strap that provides a path to ground of no less than 1 Megohm and no more than 2.5 Megohms. Alternatively the operator can ground himself before touching the bridge connectors, by touching any grounded instrument chassis. A work station equipped with an anti-static surface should be used. Never touch the center contacts of the connectors.

Tests at Hewlett-Packard have revealed that repeated ESD charges as low as 250 volts can destroy microwave diodes. Ordinary activities around everyday materials can generate ESD voltages of tens of thousands of volts. Materials conducive to static build-up include floor carpeting, nylon clothing, dry air, paper, adhesive tape, styrofoam, and vinyl. Use of the precautions described here will considerably reduce the probability of damage from ESD.

**CAUTION**

Do not apply more than +23 dBm RF power or more than +10 volts DC into the 85020A/B. If more than this power or voltage is applied, the 85020 will be damaged.

**CAUTION**

Do not drop the 85020A/B or subject it to mechanical shock, as this may cause internal damage.

**3-4. FEATURES**

3-5. Features of the 85020A/B are shown in Figure 3-1.

**3-6. CONNECTOR WEAR****CAUTION**

Do not over-tighten the connectors of the 85020A/B bridges. Excessive torque will deform the mating surfaces. To mate type-N connectors, always turn only the nut of the male connector. Never turn the Directional Bridge when making a connection. Tighten by hand only.

3-7. Repeated connections will cause the connectors to become worn, with a consequent degradation of performance. To extend the life of the connectors, it is recommended that an adapter be used on the test port in any application where some degradation of directivity can be accepted. For the most accurate measurements, a high quality adapter should be used, and the adapter should be periodically replaced. High quality adapters (low insertion loss, low return loss, stable in use, and durable) are necessary to achieve accurate, repeatable measurements. Calibrate for measurement using the same adapters and interconnect cables that will be used during measurement. To ensure repeatable measurements the adapters and cables must be clean, in good condition, and properly tightened. Start with the best available adapters and calibration standards then replace them when they become unstable. Appropriate adapters are included in the 85023-series System Verification Sets listed in Section I of this manual.

3-8. The input port connector and the test port connector are part of the microcircuit bridge assembly. This assembly may be replaced with a new or a rebuilt assembly. For information

concerning exchange assemblies, refer to Section VI, Replaceable Parts, of this manual.

3-9. The connectors are not separately replaceable. Because they are precision connectors and have contact internally with the bridge microcircuit, they cannot be repaired in the field. An attempt to replace or repair the connectors will probably cause damage to the bridge microcircuit. In addition, special fixtures are required for reassembly. For repair or replacement of any connector, return the 85020A/B to Hewlett-Packard.

### **3-10. OPERATOR'S CHECK**

3-11. Figure 3-2 is an operator's check of the 85020A, which allows the operator to make a quick check of the main system functions prior to use. Figure 3-3 is an operator's check of the 85020B. The procedures cover the entire measurement system and incorrect indications may be caused by any portion of the system. If the Directional Bridge is suspected, use the performance tests in Section IV to determine if the bridge is working correctly. If not, refer to Section VIII, Service, to isolate the problem.

### **3-12. OPERATING INSTRUCTIONS**

3-13. Instructions for operating the 85020A/B Directional Bridge with the Model 8756A Scalar Network Analyzer are supplied in Section III of the 8756A Operating and Service Manual. Figure 3-3 illustrates a typical instrument setup for transmission and reflection measurements using the 85020A/B with the 8756A.

3-14. The 8755C Scalar Network Analyzer may be substituted for the 8756A, with the addition of the 8750A Storage Normalizer in applications where memory is required. In this case, the display mainframe used with the 8755C may require modification for interface with the 8750A. A table of 8750A/Display Mainframe compatibility is provided in Section I of the 8755C Operating and Service Manual. Figure 3-4 shows a typical measurement setup using the 8755C and the 8750A.

3-15. Ratio measurements can be obtained using a power splitter in conjunction with the scalar network analyzer and detector(s). Figure 3-5 illustrates a typical ratio measurement using a power splitter.

### **3-16. 75-OHM OPERATION**

3-17. For making measurements of 75-ohm devices using the 85020B, two 50-ohm to 75-ohm minimum loss matching pads are required. One of these is connected between the signal source and the input port of the 85020B. The other is connected between the device under test and the 11664A detector on the input of the Scalar Network Analyzer.

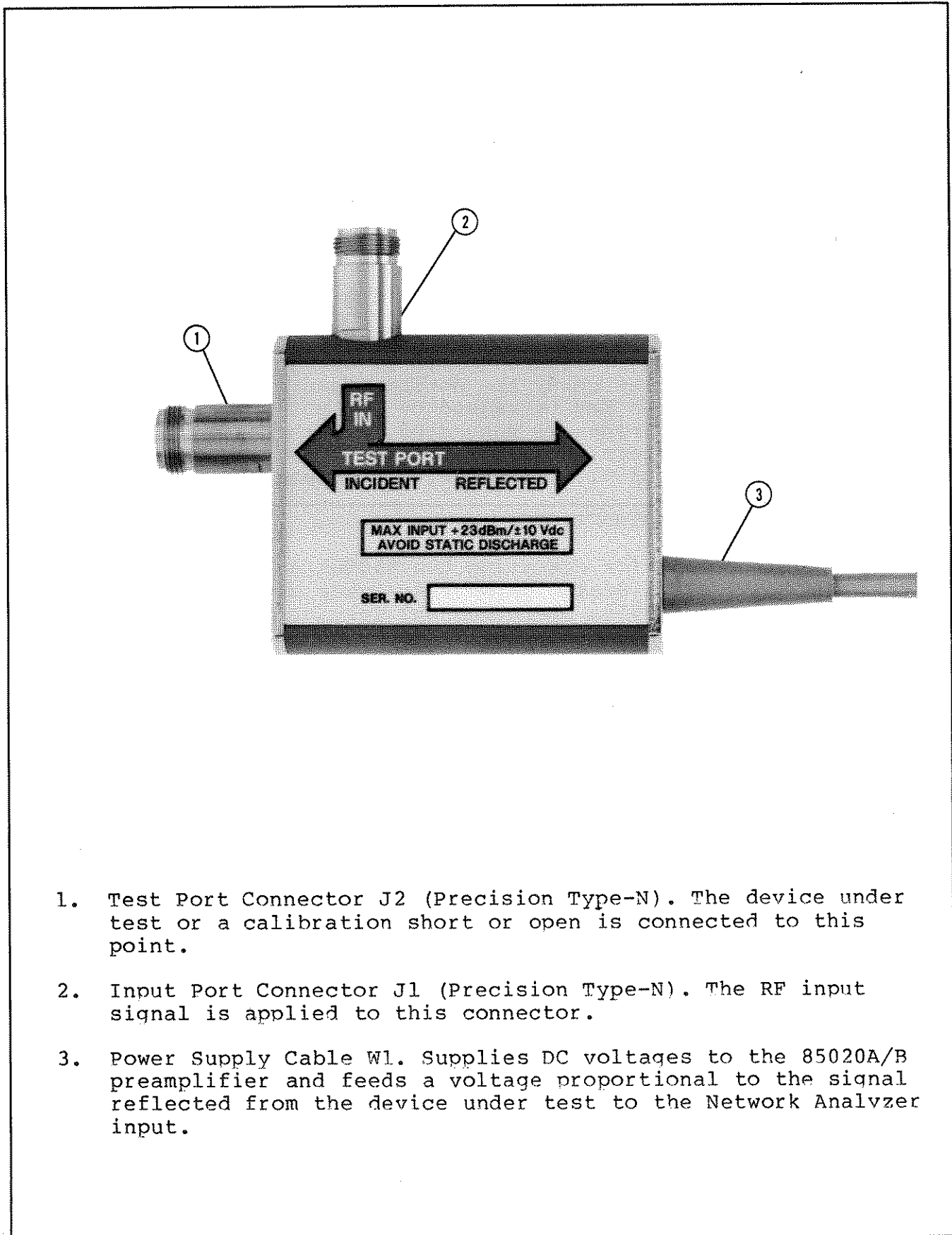

1. Test Port Connector J2 (Precision Type-N). The device under test or a calibration short or open is connected to this point.
2. Input Port Connector J1 (Precision Type-N). The RF input signal is applied to this connector.
3. Power Supply Cable W1. Supplies DC voltages to the 85020A/B preamplifier and feeds a voltage proportional to the signal reflected from the device under test to the Network Analyzer input.

Figure 3-1. 85020A/B Features (Rear View)



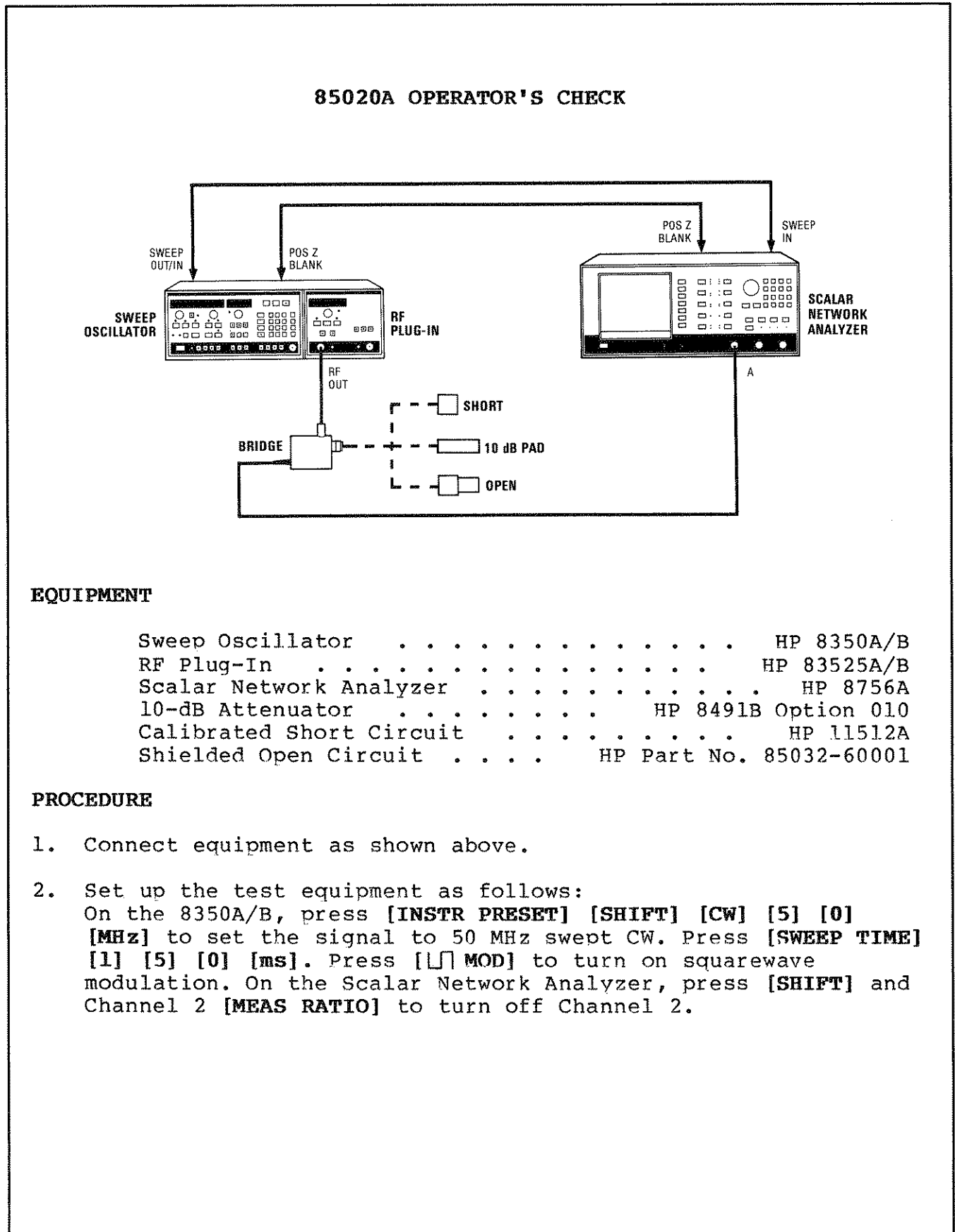

**EQUIPMENT**

Sweep Oscillator	HP 8350A/B
RF Plug-In	HP 83525A/B
Scalar Network Analyzer	HP 8756A
10-dB Attenuator	HP 8491B Option 010
Calibrated Short Circuit	HP 11512A
Shielded Open Circuit	HP Part No. 85032-60001

**PROCEDURE**

1. Connect equipment as shown above.
2. Set up the test equipment as follows:  
 On the 8350A/B, press [INSTR PRESET] [SHIFT] [CW] [5] [0] [MHz] to set the signal to 50 MHz swept CW. Press [SWEEP TIME] [1] [5] [0] [ms]. Press [L] [MOD] to turn on squarewave modulation. On the Scalar Network Analyzer, press [SHIFT] and Channel 2 [MEAS RATIO] to turn off Channel 2.

Figure 3-2. 85020A Operator's Check (1 of 2)

3. Perform an OPEN/SHORT calibration as follows:  
Press 8756A MAIN MENU soft keys [CAL] [OPEN/SHORT] [CHAN 1]. Connect the calibrated short to the test port of the 85020A, and press [STORE SHORT] to store the short calibration data. Remove the short and connect the shielded open to the test port. On the 8756A press [STORE OPEN] to store the open calibration data. On the 8756A Channel 1 press [DISPLAY] until M-MEM is selected. The Channel 1 normalized trace will be displayed.
4. Remove the shielded open and connect the 10-dB Attenuator to the 85020A test port. Leave the other end of the attenuator unterminated.
5. On the 8756A press [CURSOR]. The return loss of the unterminated pad (10 dB in each direction) will be displayed. The display should read -20 dB  $\pm$ 2dB.

*Figure 3-2. 85020A Operator's Check (2 of 2)*

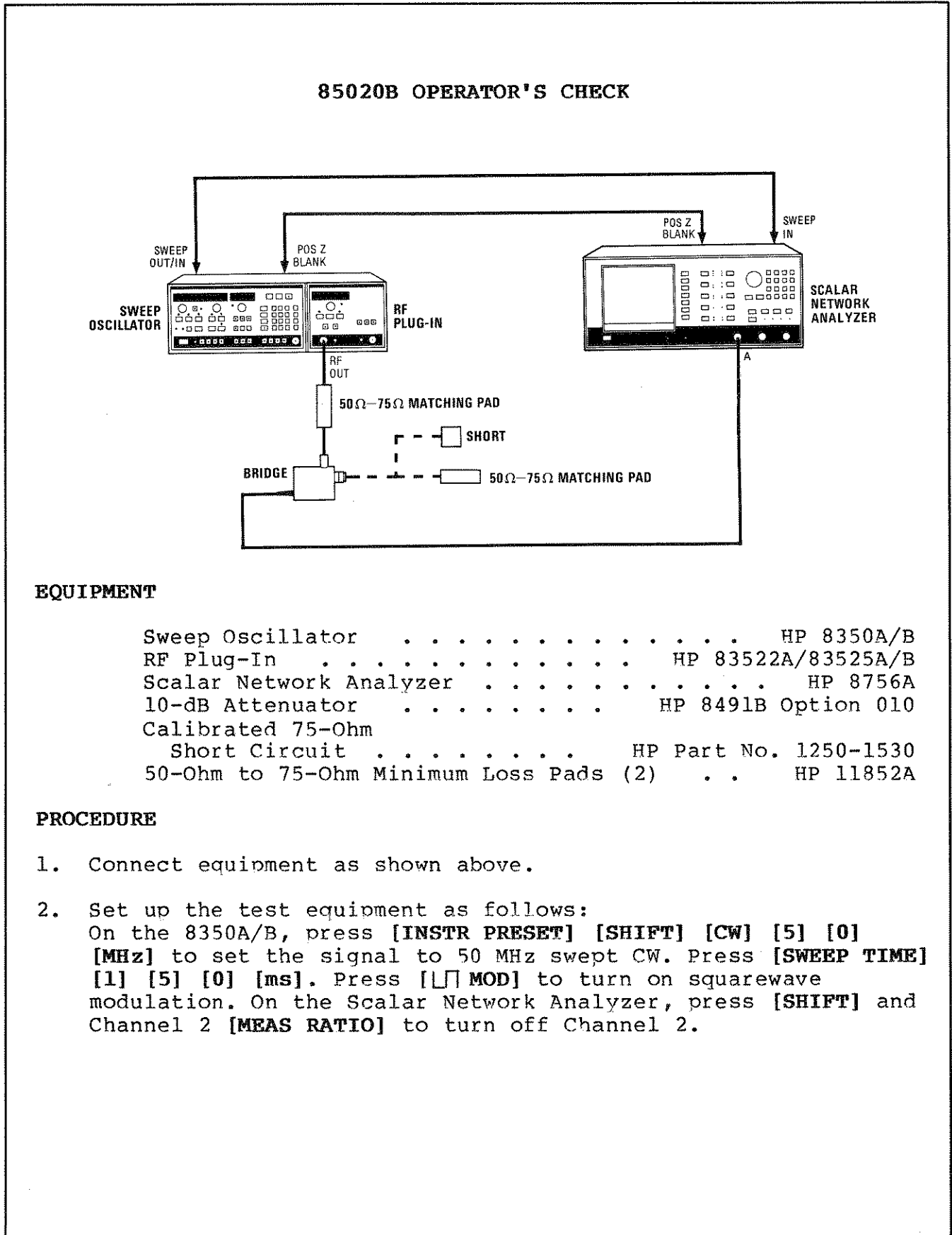

Figure 3-3. 85020B Operator's Check (1 of 2)

3. Perform an OPEN/SHORT calibration as follows:  
 Press 8756A MAIN MENU soft keys [CAL] [OPEN/SHORT] [CHAN 1]. Connect the 75-ohm calibrated short to the test port of the 85020B, and press [STORE SHORT] to store the short calibration data. Remove the short and leave the test port open. On the 8756A press [STORE OPEN] to store the open calibration data. On the 8756A Channel 1 press [DISPLAY] until M-MEM is selected. The Channel 1 normalized trace will be displayed.
4. Connect the minimum loss pad to the 85020B test port. Leave the other end of the minimum loss pad unterminated.
5. On the 8756A press [CURSOR]. The return loss of the unterminated minimum loss pad (5.7 dB in each direction) will be displayed. The display should read -11.4 dB  $\pm$  2 dB.

Figure 3-3. 85020B Operator's Check (2 of 2)

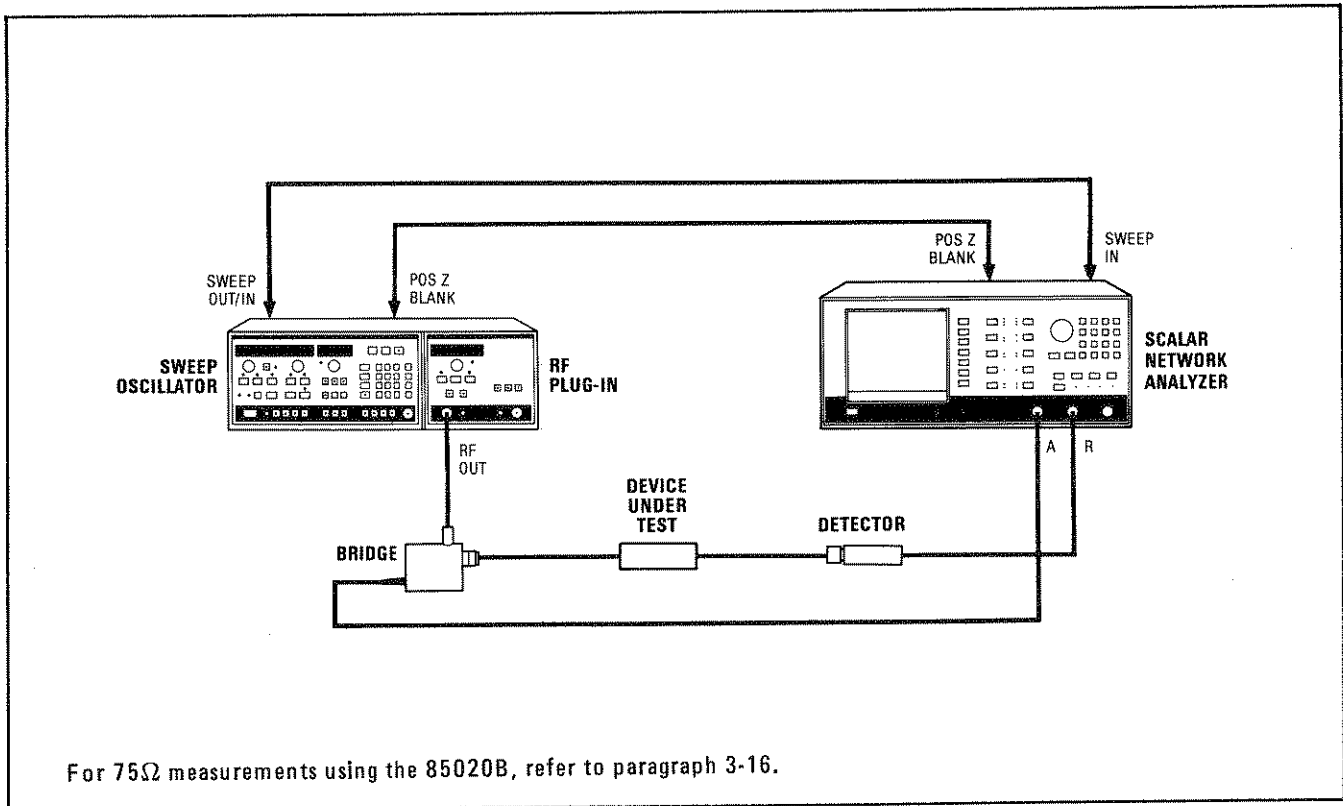

Figure 3-4. Typical Measurement Setup Using 8756A

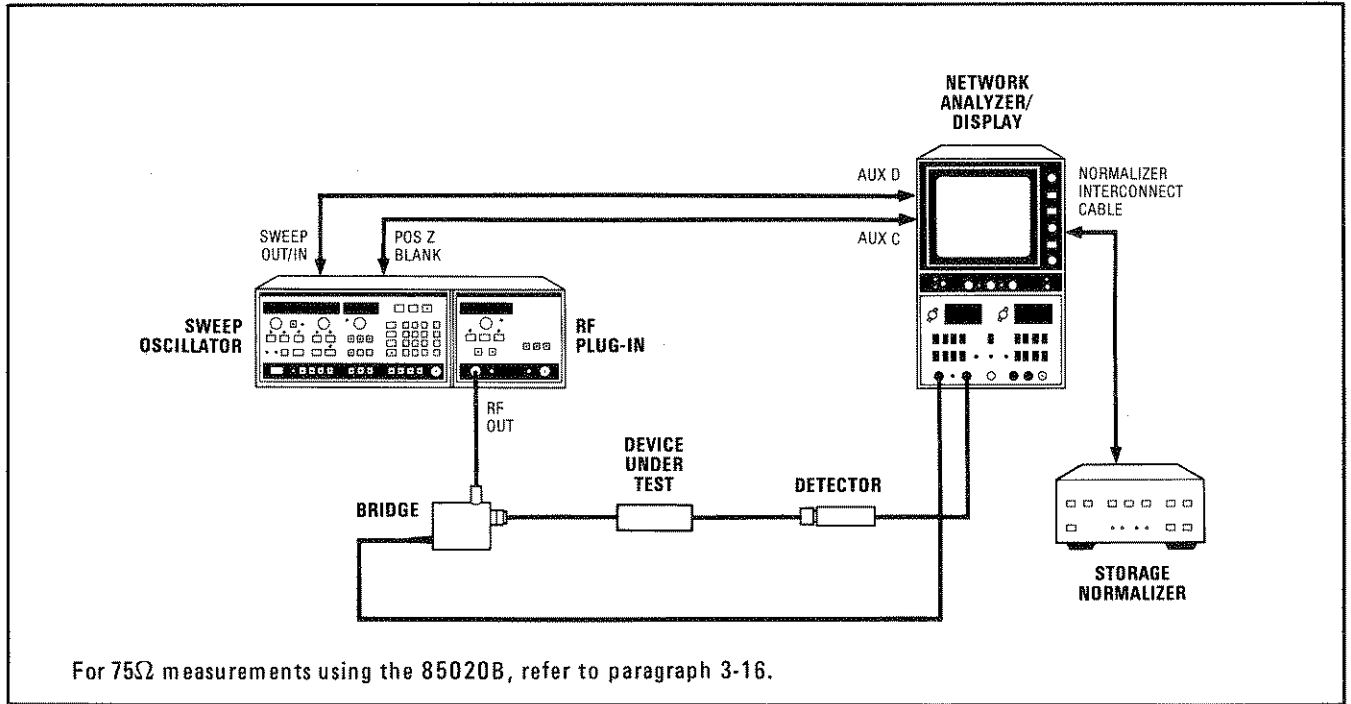

Figure 3-5. Typical Measurement Setup Using 8755C with 8750A

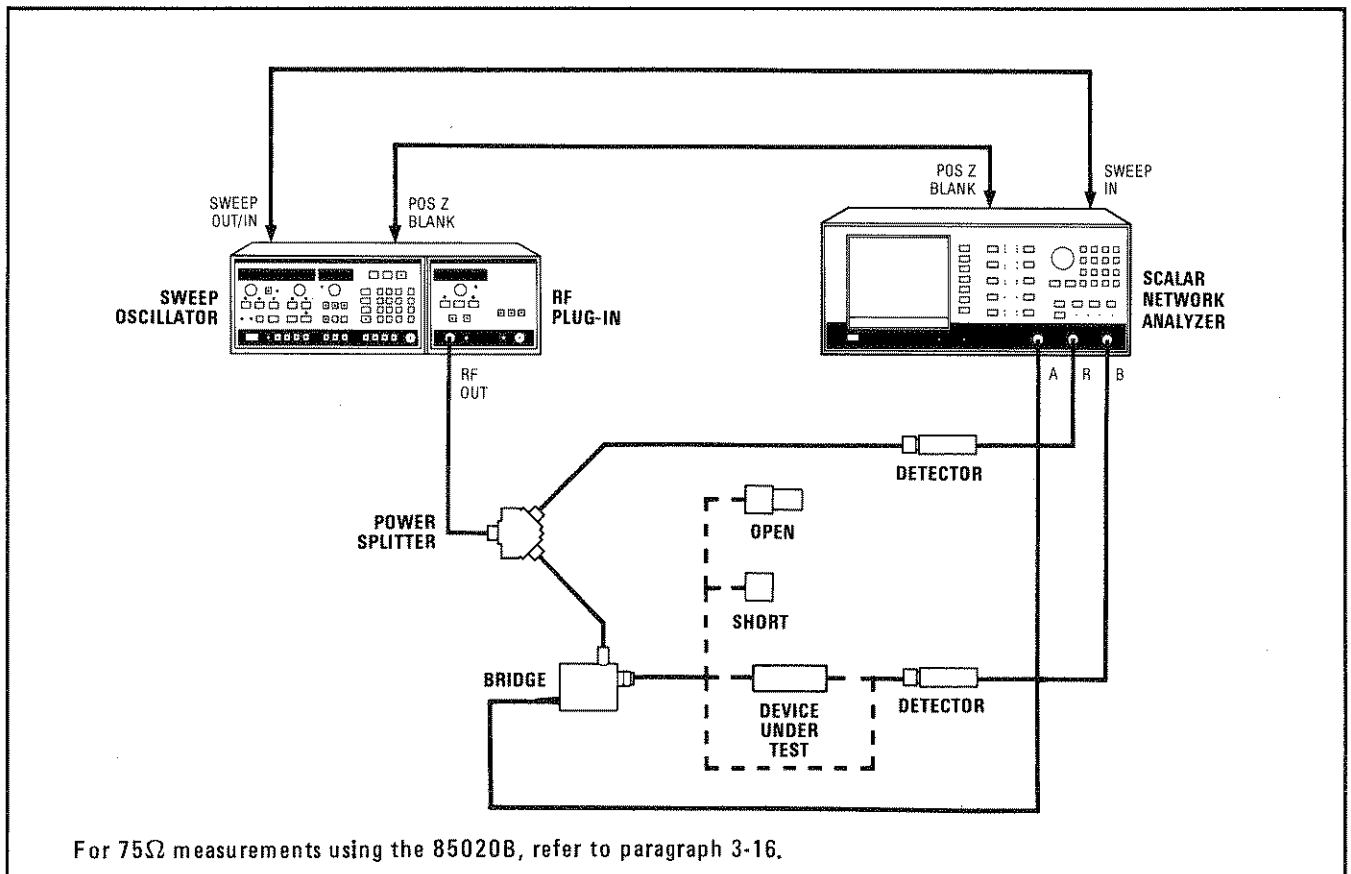

Figure 3-6. Typical Measurement Setup Using Power Splitter



**SECTION IV**  
**PERFORMANCE TESTS**

**4-1. INTRODUCTION**

4-2. The procedures in this section test the electrical performance of the 85020A/B using the specifications of Table 1-1 as the performance standards. All tests can be performed without access to the interior of the instrument.

**4-3. EQUIPMENT REQUIRED**

4-4. Equipment required for the performance tests is listed in the Recommended Test Equipment table in Section I. Any equipment that satisfies the critical specifications given in the table may be substituted for the recommended model.

**4-5. PERFORMANCE TEST RECORD**

4-6. Results of the performance tests may be tabulated on the Performance Test Record at the end of the procedures. The Performance Test Record lists all of the tested specifications and their acceptable limits. Test results recorded at incoming inspection can be used for comparison in periodic maintenance and troubleshooting and after repairs or adjustments.

**4-7. DIRECTIVITY**

**Specifications:**

	<b>85020A</b>	<b>85020B</b>
0.01 to 2.4 GHz	>40 dB	≥40 dB
2.4 to 3.0 GHz	≥40 dB	-
3.0 to 4.3 GHz	≥34 dB	-

**Description:**

Directivity is a measure of the ability of a directive device to discriminate between incident and reflected signals. In principle, directivity can be measured when the TEST port is terminated with a perfect load to eliminate all reflected signals. Any remaining signals detected are the directivity errors. However, since no perfect load is available, the test procedures below make allowances for this external error.

First an open-short calibration is performed. Then a fixed load (termination) with the best possible return loss is connected to the TEST port, and the new measured value is recorded.

**Equipment:**

- Sweep Oscillator . . . . . HP 8350A/B
- RF Plug-In . . . . . HP 83522A/83525A/B
- Scalar Network Analyzer . . . . . HP 8756A

**For Use with 85020A (50-Ohm)**

- 50-Ohm Type-N Short . . . . . HP 11512A
- 50-Ohm Shielded Open . . . . . HP 85032-60001
- 50-Ohm Termination . . . . . HP 909A Opt. 012

**For Use with 85020B (75-Ohm)**

- 50-Ohm to 75-Ohm Minimum Loss Pad . . . . . HP 11852A
- 75-Ohm Type-N Short . . . . . HP 1250-1530
- 75-Ohm Termination . . . . . HP 1250-1532



**Do not mix 50-ohm and 75-ohm hardware, as this may damage the connectors.**



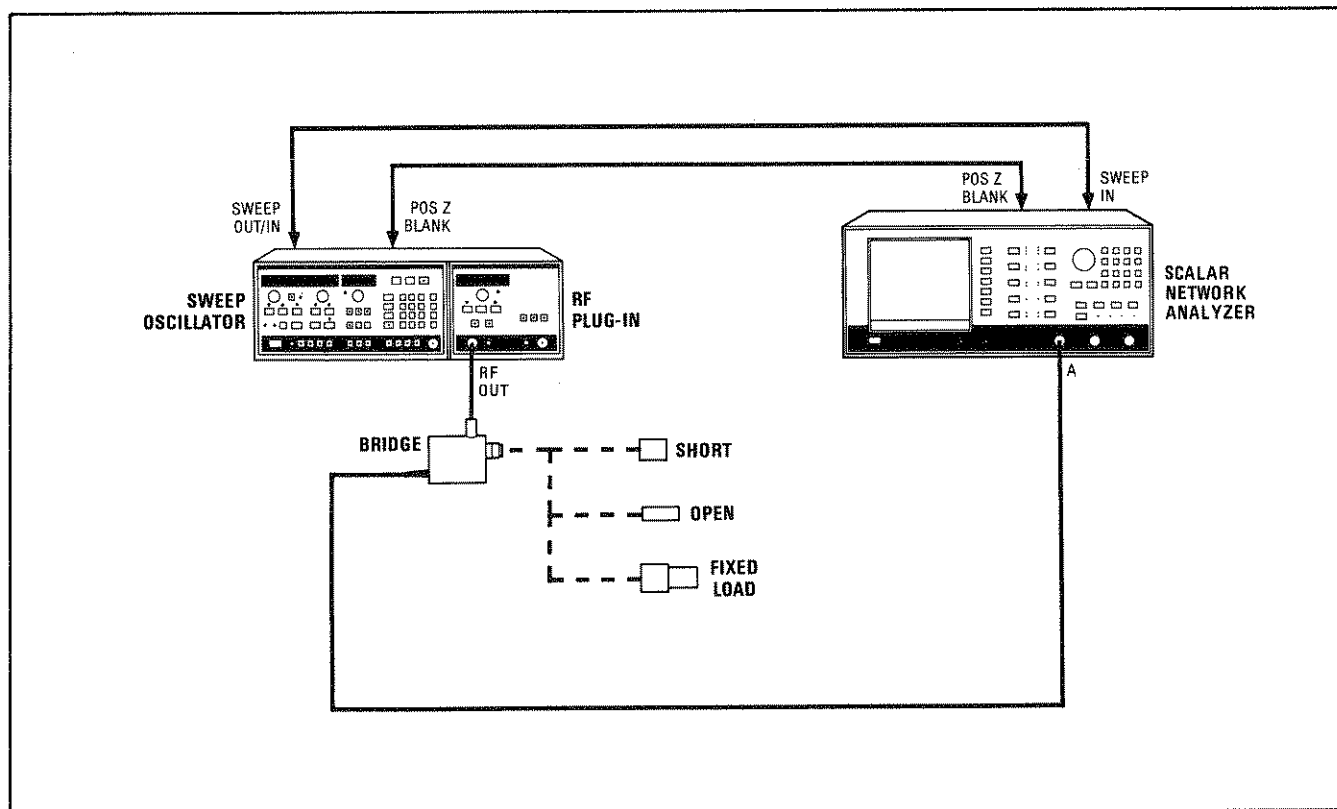

Figure 4-1. Directivity Test Setup

### Procedure

1. Connect the equipment as shown in Figure 4-1. If the Directional Bridge is an 85020B, connect the Model 11852A 50-ohm to 75-ohm minimum loss pad between the output of the RF Plug-In and the input port of the Directional Bridge. Do not connect the fixed load (termination) at this time. Allow the equipment to warm up for 30 minutes.
2. Set up the test equipment as follows:  
On Sweep Oscillator, press **[INSTR PRESET] [SWEEP TIME] [1] [5] [0] [ms] [L] MOD**. On the RF Plug-In, RF power is ON. On the Scalar Network Analyzer, press **[PRESET]**, then turn off Channel 2 by pressing **[SHIFT]** and Channel 2 **[MEAS RATIO]**.
3. On the 8350A/B Sweep Oscillator, set the START and STOP frequencies to correspond to the first band of frequencies in Table 4-1, the Performance Test Record (0.01 to 2.4 GHz).
4. Perform an open/short calibration, using the correct equipment listed above for the respective Directional Bridges. For OPEN calibration of the 85020B, leave the test port unterminated.
5. Connect the fixed load to the TEST port of the 85020A/B. On

the 8756A, press [SHIFT] [SCALE] for the AUTOSCALE function, then press [CURSOR] [CURSOR MAX 1] to find the point of minimum return loss (the high point on the trace). Record the displayed CURSOR value on the Performance Test Record, Table 4-1. This value represents the scalar sum of directivity signals (desired measurement) plus reflected signals from the fixed load (undesired error). Thus, fixed load quality directly affects the quality of directivity measurements. Refer to Figure 4-2. The shaded areas in this figure indicate the probable range of measurable values for each specified directivity value. On the horizontal axis, locate the fixed load's reflection coefficient or its specified return loss (convert from SWR, if necessary). Move up from this point to the upper limit of the shaded area between the diagonal lines. Enter the value of this upper limit on the Performance Test Record, Table 4-1. Allowing for the load error, any directivity measurement that falls below this limit indicates that the 85020A/B is probably within specifications for the frequency band of interest. If the measurement falls above the upper limit, the bridge does not meet specifications, and troubleshooting procedures should be performed.

- On the 8350A/B Sweep Oscillator, set the START and STOP frequencies to the next band listed in Table 4-1 (2.4 to 3.0 GHz). Repeat Steps 4 and 5.

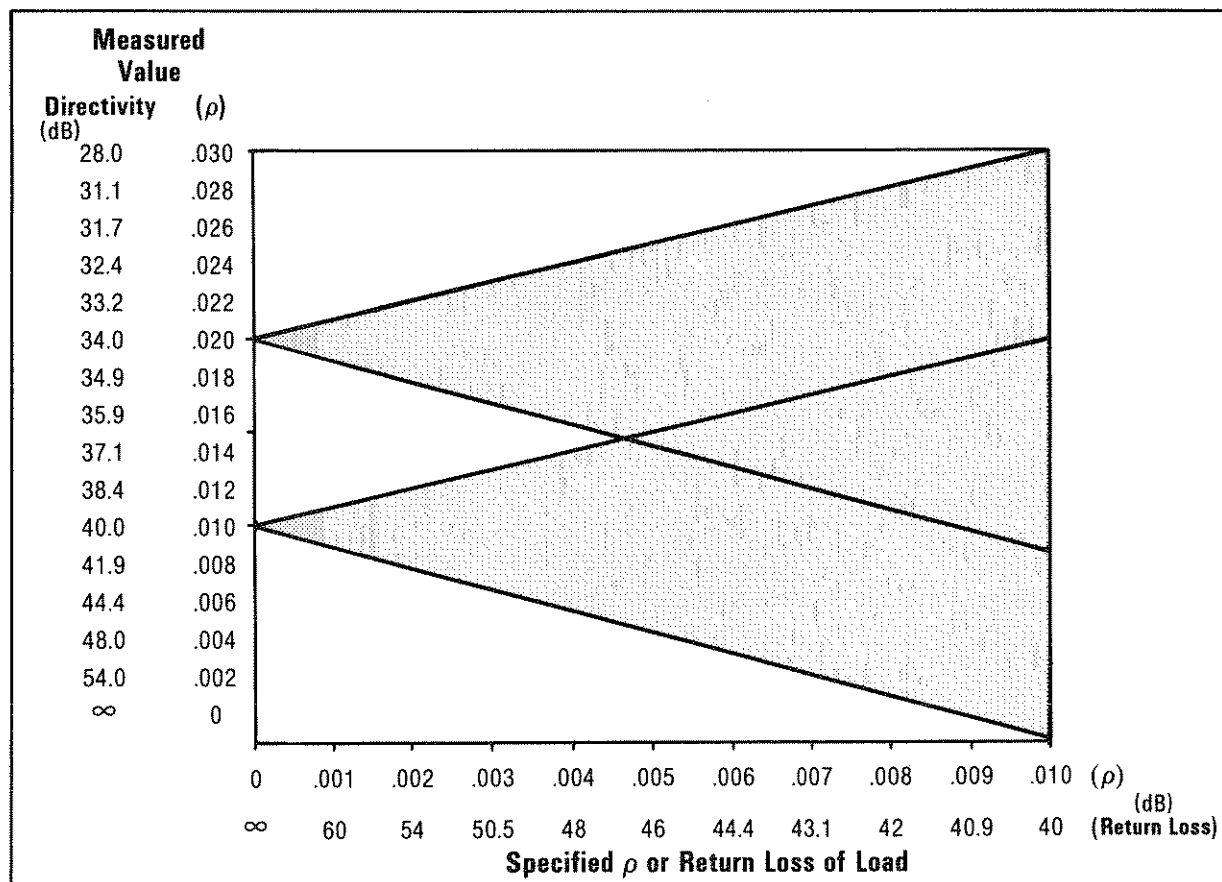

Figure 4-2. Probable Range of Measurable Directivity Values

**4-8. TEST PORT MATCH (SWR)**

**Specifications:**

	85020A	85020B
0.01 to 1.3 GHz	<1.20	<1.25
1.3 to 2.4 GHz	<1.20	<1.39
2.4 to 3.0 GHz	<1.20	-
3.0 to 4.3 GHz	<1.25	-

**Description:**

Using a typical reflection measurement setup, another Directional Bridge is used to measure the test port SWR of the Directional Bridge under test. The RF IN port of the Directional Bridge under test must be properly terminated.

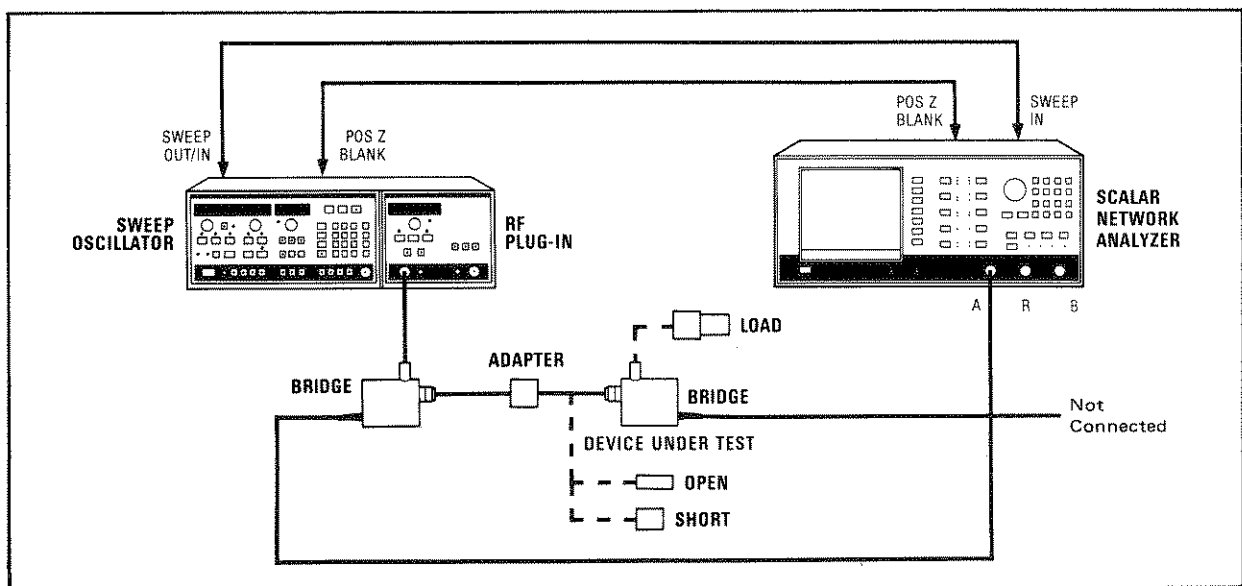

Figure 4-3. TEST Port SWR Test Setup

**Equipment:**

- Sweep Oscillator . . . . . HP 8350A/B
- RF Plug-In . . . . . HP 83522A/83525A/B
- Scalar Network Analyzer . . . . . HP 8756A
- Directional Bridge\* . . . . . HP 85020A/B
- Adapter, Type-N(m) to Type-N(m) . . . . . HP 1250-1475

\*A second Directional Bridge of the same type is required as a test instrument in addition to the Directional Bridge under test.

**Equipment (continued)****For Use with 85020A (50-Ohm)**

50-Ohm Type-N Short . . . . .	HP 11512A
50-Ohm Shielded Open . . . . .	HP 85032-60001
50-Ohm Termination . . . . .	HP 909A Opt. 012

**For Use with 85020B (75-Ohm)**

50-Ohm to 75-Ohm Minimum Loss Pad . . . . .	HP 11852A
75-Ohm Type-N Short . . . . .	HP 1250-1530
75-Ohm Termination . . . . .	HP 1250-1532

**CAUTION**

**Do not mix 50-ohm and 75-ohm hardware, as this may damage the connectors.**

**Procedure:**

1. Set up the equipment as shown in Figure 4-3, with the appropriate calibrated short connected to the Directional Bridge (the test device, not the device under test). If the Directional Bridge is an 85020B, connect the Model 11852A 50-ohm to 75-ohm minimum loss pad between the output of the RF Plug-In and the input port of the Directional Bridge.
2. Set up the test equipment as follows:  
On the Sweep Oscillator, press **[INSTR PRESET] [SWEEP TIME] [1] [5] [0] [ms] [ ] MOD]**. On the Scalar Network Analyzer, press **[PRESET]**, then turn off Channel 2 by pressing **[SHIFT]** and Channel 2 **[MEAS RATIO]**.
3. On the 8350A/B Sweep Oscillator, set the START and STOP frequencies to correspond to the first band of frequencies in the Performance Test Record (0.01 to 1.3 GHz).
4. Perform an open/short calibration using the correct equipment listed above for the respective Directional Bridges. For OPEN calibration of the 85020B, leave the test port unterminated.
5. Connect the Directional Bridge under test to the first Directional Bridge, TEST port to TEST port, using an adapter. Leave the cable of the Directional Bridge under test unconnected. Connect a matched load to the input port of the Directional Bridge under test.
6. On the 8756A, press **[SHIFT] [SCALE]** for the AUTOSCALE function, then press **[CURSOR] [CURSOR MAX 1]** to find the point of minimum return loss (the high point on the trace). Use the reflectometer calculator to convert this measured return loss

to SWR. Enter this value on the Performance Test Record, Table 4-1.

7. On the Sweep Oscillator, set the START and STOP frequencies to the next band of interest listed on the Performance Test Record. Repeat steps 4 through 7 for each frequency band.

Table 4-1. Performance Test Record

<b>DIRECTIVITY</b>				
<b>Frequency Range</b>	<b>Step</b>	<b>Scalar Sum of Directivity Signals</b>	<b>Upper Limit (from Fig. 4-2)</b>	
0.01 to 2.4 GHz	5	_____	_____	
2.4 to 3.0 GHz	5	_____	_____	
3.0 to 4.3 GHz	5	_____	_____	
<b>TEST PORT MATCH (SWR)</b>				
<b>Frequency Range</b>	<b>Step</b>	<b>Calculated SWR</b>	<b>Specified Upper Limit</b>	
			<b>85020A</b>	<b>85020B</b>
0.01 to 1.3 GHz	6	_____	1.20	1.25
1.3 to 2.4 GHz	6	_____	1.20	1.39
2.4 to 3.0 GHz	6	_____	1.20	-
3.0 to 4.3 GHz	6	_____	1.25	-

**SECTION V**  
**ADJUSTMENTS**

**5-1. INTRODUCTION**

5-2. There are no adjustments recommended for regular calibration or normal use of the 85020A/B Directional Bridge. However, if the internal bridge microcircuit is replaced, adjustments must be made to compensate the preamplifier for the individual diode characteristics. The procedures for replacing the bridge microcircuit and adjusting the preamplifier are described in Section VIII, Service, of this manual.





## SECTION VI

### REPLACEABLE PARTS

#### 6-1. INTRODUCTION

6-2. This section contains information for ordering parts. Table 6-1 lists the available exchange assemblies. Table 6-2 lists abbreviations used in the parts lists and the names and addresses that correspond with the manufacturers' code numbers. Tables 6-3A and 6-3B list the replaceable parts in reference designator order for the 85020A and 85020B separately. Only the listed parts are replaceable.

#### 6-3. EXCHANGE ASSEMBLIES

6-4. The microcircuit bridge assembly, including input and test port connectors and the reference termination, may be replaced on an exchange basis, thus affording a considerable cost savings. Table 6-1 lists these assemblies for both Directional Bridges, together with the part numbers for the exchange assemblies. Exchange, factory repaired and tested assemblies are available only on a trade-in basis; therefore, the defective assemblies must be returned for credit. For this reason, assemblies required for spare parts stock must be ordered by the new assembly part number.

#### 6-5. ABBREVIATIONS

6-6. Table 6-2 contains three major sections: Reference Designations expands the designators used in the parts list; Abbreviations defines all abbreviations used in the descriptions of replaceable parts; Manufacturers Code List references the name and address of a typical manufacturer with the code number provided in the parts list.

#### 6-7. REPLACEABLE PARTS LISTS

6-8. Tables 6-3A/B are the lists of replaceable parts for the 85020A and 85020B respectively, and are organized as follows:

- a. Electrical assemblies and their components in alpha-numerical order by reference designation.
- b. Chassis-mounted parts in alpha-numerical order by reference designation.
- c. Miscellaneous parts.

6-9. The information given for each part consists of the following:

- a. The Hewlett-Packard part number.
- b. Part number check digit (CD).
- c. The total quantity (Qty) in the instrument.
- d. The description of the part.
- e. A typical manufacturer of the part in a five-digit code.
- f. The manufacturer's number for the part.

6-10. The total quantity for each part is given only once for each instrument - at the first appearance of the part number in the list for that instrument.

**6-11. ILLUSTRATIONS**

6-12. Figure 6-1, Replaceable Parts Identification, illustrates the locations of miscellaneous replaceable parts, some of which are also listed in Tables 6-3A/B. These parts are denoted with reference designation prefix MP.

**6-13. ORDERING INFORMATION**

6-14. To order a part listed in the Replaceable Parts Lists, quote the Hewlett-Packard part number with its check digit (CD), indicate the quantity, and address the order to the nearest Hewlett-Packard Office. The check digit will ensure accurate and timely processing of your order.

6-15. To order a part that is not listed in the Replaceable Parts List, include the instrument model number, instrument serial number, description and function of the part, and the number of parts required. Address the order to the nearest Hewlett-Packard Office.

*Table 6-1. Exchange Microcircuit Bridge Assemblies*

(Includes input and test port connectors and reference termination.)

INSTRUMENT	NEW PART NUMBER	REBUILT-EXCHANGE PART NUMBER
85020A 85020B	5086-7375 5086-7391	5086-6375 5086-6391

Table 6-2. Manufacturers Code List, Reference Designations and Abbreviations

MANUFACTURERS CODE LIST			
MFR NO	MANUFACTURER NAME	ADDRESS	ZIP CODE
00000	ANY SATISFACTORY SUPPLIER		
06383	PANDUIT CORP	TINLEY PARK IL	60477
06665	PRECISION MONOLITHICS INC	SANTA CLARA CA	95050
15526	METRIC AND MULTISTANDARD COMPONENT CORP	ELMSFORD NY	10523
24546	CORNING GLASS WORKS	BRADFORD PA	16701
28480	HEWLETT-PACKARD CORP HQ	PALO ALTO CA	94304
REFERENCE DESIGNATIONS			
A... Assembly		R... Resistor	
AT... Termination		U... Integrated Circuit	
C... Capacitor		TP... Test Point	
CR... Diode		MP... Miscellaneous Part	
J... Jack, Connector		W... Cable, Wire	
ABBREVIATIONS			
ADJ... Adjust, Adjustment		MTG... Mounting	
AWG... American Wire Gage		NS... Nanosecond	
CER... Ceramic		NYL... Nylon (Polvamide)	
CHAM... Chamfer		OP AMP... Operational Amplifier	
COND... Conductor		PF... Picofarad	
CORR... Corrugated		PKG... Package	
CR... Crystal Rectifier		PL... Plate, Plug	
DBL... Double		PRCN... Precision	
DEG... Degree		RLG... Rolling	
DIA... Diameter		RSC... Regular Slotted Container	
DIP... Dual In-Line Package		SCR... Screw	
DO... Package Type Designation		SLDR... Solder	
F... Film (Resistor), Fixed		T... Tab Width, Taper	
FLH... Flat Head		TA... Tantalum	
FXD... Fixed		TC... Thermoplastic	
HEX... Hexagonal		THD... Thread, Threaded	
IC... Integrated Circuit		THK... Thick	
ID... Inside Diameter		TO... Package Type Designation	
IN... Inch		TRMR... Trimmer	
INTL... Internal		TRN... Turn, Turns	
K... Kilo		UF... Microfarad	
LG... Length, Long		V... Volt, Voltage	
LK... Lock		VDC... Volts, Direct Current	
M... Mounting Hole Diameter		W... Watt, Wattage	
MA... Milliampere		WD... Width	
MACH... Machined			
MM... Millimeter			

Table 6-3A. Model 85020A Replaceable Parts

Reference Designation	HP Part Number	C D	Qty	Description	Mfr Code	Mfr Part Number
A1	5086-7375	3	1	BRIDGE ASSEMBLY (INCLUDES CONNECTORS J1 AND J2 AND REFERENCE TERMINATION AT1) REBUILT 5086-7375	28480	5086-7375
A1	5086-6375	1			28480	5086-6375
A2	85020-60001	5	1	BOARD ASSEMBLY-PREAMPLIFIER	28480	85020-60001
A2C1	0180-2794	5	2	CAPACITOR-FXD 3.3UF+20% 35VDC TA	28480	0180-2794
A2C2	0180-2794	5		CAPACITOR-FXD 3.3UF+20% 35VDC TA	28480	0180-2794
A2C3	0160-3878	6	1	CAPACITOR-FXD 1000PF+20% 100VDC CER	28480	0160-3878
A2CR1	1901-0050	3	2	DIODE-SWITCHING 80V 200MA 2NS DO-35	28480	1901-0050
A2CR2	1901-0050	3		DIODE-SWITCHING 80V 200MA 2NS DO-35	28480	1901-0050
A2R1	0698-7205	0	1	RESISTOR 51.1 1% .05W F TC=0+100	24546	C3-1/8-T0-51R1-F
A2R2	2100-3210	6	1	RESISTOR-TRMR 10K 10% C TOP-ADJ 1-TRN	28480	2100-3210
A2R3	0698-7248	1	1	RESISTOR 3.16K 1% .05W F TC=0+100	24546	C3-1/8-T0-3161-F
A2R4	2100-3253	7	1	RESISTOR-TRMR 50K 10% C TOP-ADJ 1-TRN	28480	2100-3253
A2R5	0698-7212	9	1	RESISTOR 100 1% .05W F TC=0+100	24546	C3-1/8-T0-100R-F
A2U1	1826-0932	0	1	IC OP AMP PRCN 8-DIP-C PKG	06665	OP27FZ
A2TP1	0360-0535	0	1	TERMINAL-TEST POINT .330IN ABOVE	28480	0360-0535
MP1	5001-1590	4	1	DRESS COVER	28480	5001-1590
MP2	7100-1275	4	1	END COVER	28480	7100-1275
MP3	5021-3587	5	1	EXTRUDED FRAME	28480	5021-3587
MP4	7100-1276	5	1	PORT COVER	28480	7100-1276
MP5	2950-0001	8	1	NUT-HEX-DBL-CHAM 3/8-32-THD .094-IN-THK	28480	2950-0001
MP6	2190-0016	3	1	WASHER-LK INTL T 3/8-IN .377-IN-ID	28480	2190-0016
MP7	0360-1190	5	1	TERMINAL-SLDR LOG/PL-MTG FOR-#3/8-SCR	28480	0360-1190
MP8	0515-0823	8	4	SCREW-THD-RLG M3X0.5 10MM-LG	28480	0515-0823
MP9	1531-0289	5	1	BRIDGE SPACER S-ST	28480	1531-0289
MP10	0515-0820	5	4	SCREW-MACH M2X0.4 5MM-LG 90 DEG FLN	15526	963SX (M2.5)
MP11	7121-4309	5	1	85020A IDENTIFICATION LABEL	28480	7121-4309
MP12	1400-0249	0	1	CABLE TIE .062-.625-DIA .091-WD NYL	06383	PLTIM-8
MP13	1540-0181	5	1	85020A INSTRUMENT CASE	28480	1540-0181
MP14	85020-80001	7	1	FOAM PAD IN INSTRUMENT CASE	28480	85020-80001
MP15	7121-4311	9	1	INSTRUMENT CASE LABEL	28480	7121-4311
MP16	5952-0948	9	1	REFLECTOMETER CALCULATOR	28480	5952-0948
MP17	9211-0046	2	1	CARTON CORR RSC 11.5-IN-LG 8.625-IN-WD	28480	9211-0046
W1	8120-3804		1	POWER CORD ASSEMBLY 24-AWG 4-COND	28480	8120-3804

See introduction to this section for ordering information  
 \*Indicates factory selected value

Table 6-3B. Model 85020B Replaceable Parts

Reference Designation	HP Part Number	C D	Qty	Description	Mfr Code	Mfr Part Number
A1	5086-7391	3	1	BRIDGE ASSEMBLY (INCLUDES CONNECTORS J1 AND J2 AND REFERENCE TERMINATION AT1)	28480	5086-7391
A1	5086-6391	1		REBUILT 5086-7391	28480	5086-6391
A2	85020-60001	5	1	BOARD ASSEMBLY-PREAMPLIFIER	28480	85020-60001
A2C1	0180-2794	5	2	CAPACITOR-FXD 3.3UF±20% 35VDC TA	28480	0180-2794
A2C2	0180-2794	5		CAPACITOR-FXD 3.3UF±20% 35VDC TA	28480	0180-2794
A2C3	0160-3878	6	1	CAPACITOR-FXD 1000PF±20% 100VDC CER	28480	0160-3878
A2CR1	1901-0050	3	2	DIODE-SWITCHING 80V 200MA 2NS DO-35	28480	1901-0050
A2CR2	1901-0050	3		DIODE-SWITCHING 80V 200MA 2NS DO-35	28480	1901-0050
A2R1	0698-7205	0	1	RESISTOR 51.1 1% .05W F TC=0±100	24546	C3-1/8-TO-51R1-F
A2R2	2100-3210	6	1	RESISTOR-TRMR 10K 10% C TOP-ADJ 1-TRN	28480	2100-3210
A2R3	0698-7248	1	1	RESISTOR 3.16K 1% .05W F TC=0±100	24546	C3-1/8-TO-3161-F
A2R4	2100-3253	7	1	RESISTOR-TRMR 50K 10% C TOP-ADJ 1-TRN	28480	2100-3253
A2R5	0698-7212	9	1	RESISTOR 100 1% .05W F TC=0±100	24546	C3-1/8-TO-100R-F
A2U1	1826-0932	0	1	IC OP AMP PRCN 8-DIP-C PKG	06665	OP27FZ
A2TP1	0360-0535	0	1	TERMINAL-TEST POINT .330IN ABOVE	28480	0360-0535
MP1	5001-1590	4	1	DRESS COVER	28480	5001-1590
MP2	7100-1275	4	1	RND COVER	28480	7100-1275
MP3	5021-3587	5	1	EXTRUDED FRAME	28480	5021-3587
MP4	7100-1276	5	1	PORT COVER	28480	7100-1276
MP5	2950-0001	8	1	NUT-HEX-DRL-CHAM 3/8-32-THD .094-IN-THK	28480	2950-0001
MP6	2190-0016	3	1	WASHER-LK INCL T 3/8-IN .377-IN-ID	28480	2190-0016
MP7	0360-1190	5	1	TERMINAL-SLDR LHG PL-MTG FOR-#3/8-SCR	28480	0360-1190
MP8	0515-0823	8	4	SCREW-THD-RIG M3X0.5 10MM-LG	28480	0515-0823
MP9	1531-0289	5	1	BRIDGE SPACER S-ST	28480	1531-0289
MP10	0515-0820	5	4	SCREW-MACH M2X0.4 5MM-LG 90 DEG FLH	15526	9635X (M2.5)
MP11	7121-4534	8	1	85020B IDENTIFICATION LABEL	28480	7121-4534
MP12	1400-0249	0	1	CABLE TYP .862-.625-DIA .691-WD NYL	06383	PLTIM-8
MP13	1540-0181	5	1	85020B INSTRUMENT CASE	28480	1540-0181
MP14	85020-80001	7	1	FOAM PAD IN INSTRUMENT CASE	28480	85020-80001
MP15	7121-4535	9	1	INSTRUMENT CASE LABEL	28480	7121-4535
MP16	5952-0948	9	1	REFLECTOMETER CALCULATOR	28480	5952-0948
MP17	9211-0046	2	1	CARTON CORR RSC 11.5-IN-LG 8.625-IN-WD	28480	9211-0046
W1	8120-3804		1	POWER CORD ASSEMBLY 24-AWG 4-COND	28480	8120-3804

See introduction to this section for ordering information  
 \*Indicates factory selected value

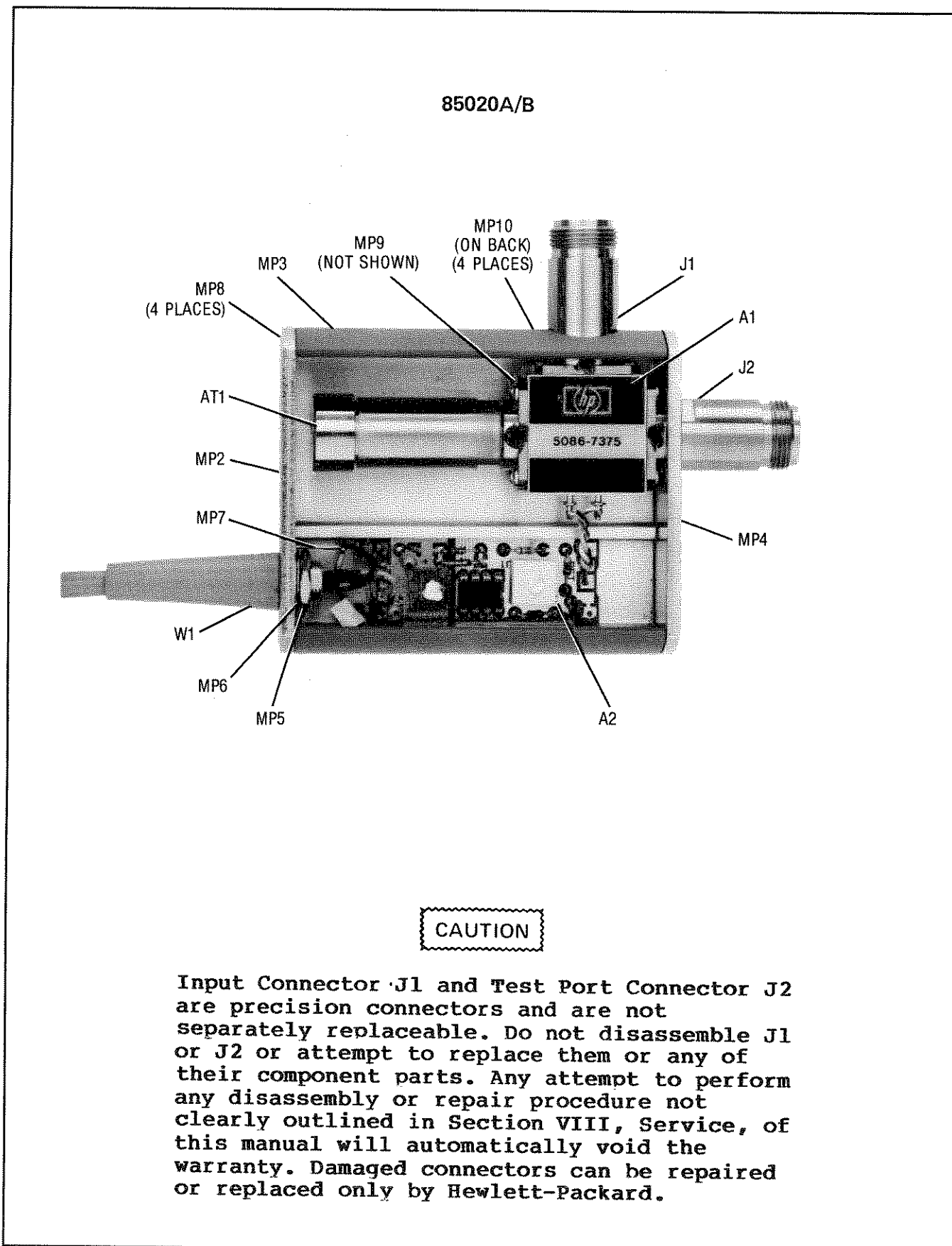

Figure 6-1. 85020A/B Replaceable Parts Identification

**SECTION VII****MANUAL BACKDATING CHANGES****7-1. INTRODUCTION**

7-2. This section of the manual normally contains backdating information to adapt the manual so that it applies to earlier versions or configurations of the instrument which may be slightly different in design or appearance. Later versions of the instrument will be documented in a yellow Manual Changes supplement.

7-3. Since there are no earlier versions of the HP Model 85020A/B Directional Bridge, this manual applies directly to all instruments manufactured before the print date, and therefore no change information is given here. Refer to INSTRUMENTS COVERED BY MANUAL in Section I for additional information about Manual Changes supplements and changes keyed to specific serial numbers.





## SECTION VIII

### SERVICE

#### 8-1. INTRODUCTION

8-2. This section provides instructions for troubleshooting and repair of the 85020A/B Directional Bridge.

#### 8-3. CAUTION NOTES

8-4. The CAUTION sign denotes a hazard to the instrument. It calls attention to an operating, maintenance, or repair procedure which, if not correctly performed or adhered to, could result in damage to or destruction of part or all of the instrument. Do not proceed beyond a CAUTION sign until the indicated conditions are fully understood and met.

#### 8-5. THEORY OF OPERATION

8-6. The operation of the 85020A/B is described to assist with troubleshooting procedures. Schematic diagrams are supplied for the A1 directional bridge circuit and the A2 preamplifier, together with a component locations diagram for the A2 preamplifier assembly.

#### 8-7. TROUBLESHOOTING

8-8. Troubleshooting the 85020A/B involves performing the Operator's Check and the Performance Tests. If a problem persists, refer to TROUBLESHOOTING PROCEDURES later in this section. The troubleshooting procedures are designed to help the technician isolate a problem to the defective component. A troubleshooting flow diagram is provided in Figure 8-4.

#### 8-9. RECOMMENDED TEST EQUIPMENT

8-10. Equipment recommended to test and maintain the instrument is listed in Section I, General Information. If the equipment listed is not available, equipment that meets the critical specifications listed may be substituted.

8-11. **REPAIR AND REPLACEMENT**

8-12. The following procedures are described:

- Power cable replacement
- Preamplifier assembly replacement
- Replacement of the bridge microcircuit assembly
- Preamplifier adjustment following replacement of the bridge microcircuit assembly

## THEORY OF OPERATION

## A1 Bridge Circuit

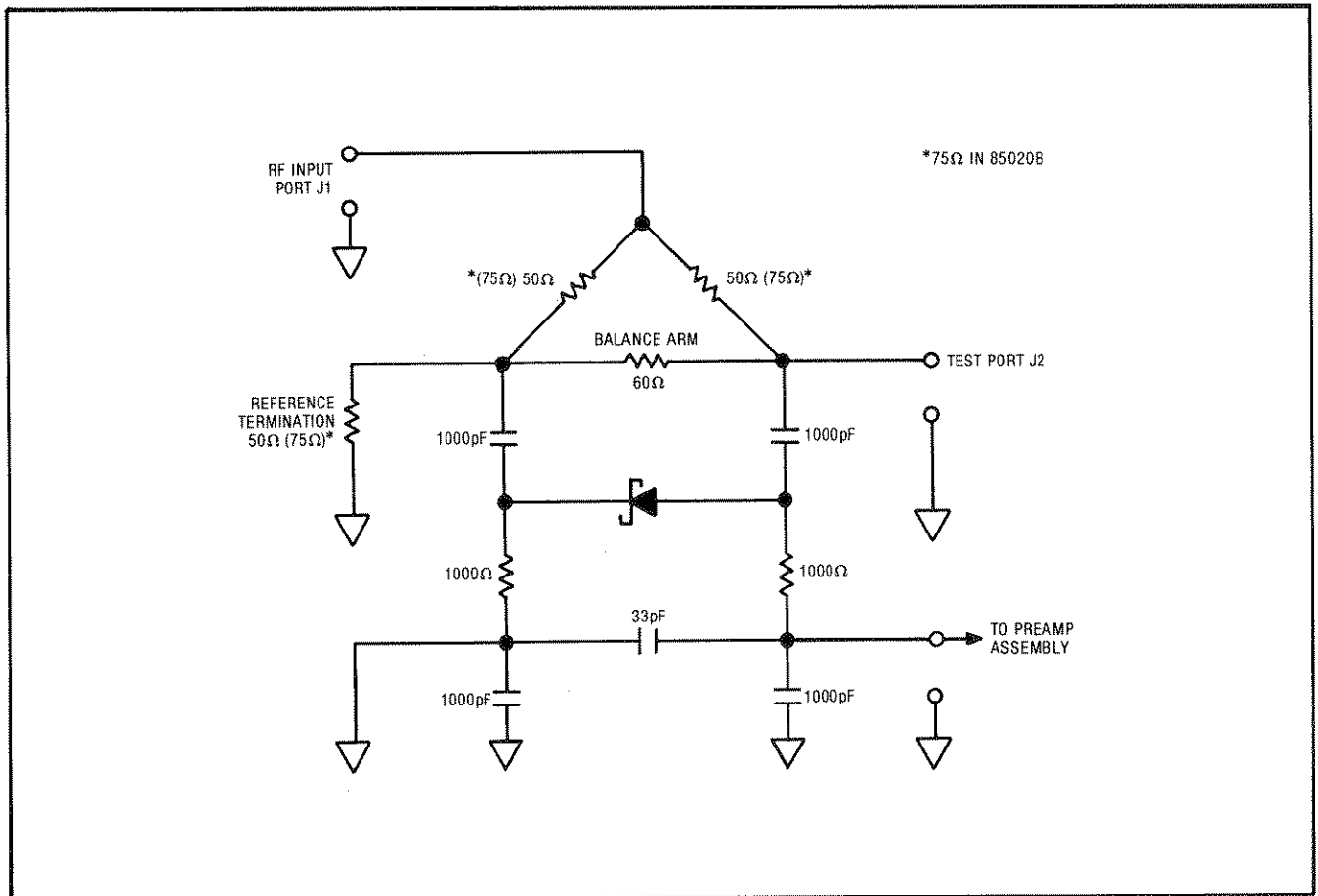

Figure 8-1. A1 Bridge Circuit Schematic Diagram

The 85020A/B Directional Bridge is a broadband device used to measure return loss. The voltage across the balance arm (see Figure 8-1) is proportional to the return loss of the device under test. Placing a diode across the balance arm enables the conversion of the microwave voltage to a 27 kHz square wave whose amplitude is proportional to the return loss. The 1000-ohm isolation resistors and the 1000-pF capacitors serve to isolate the balanced detector from the Network Analyzer. This buffers the output, reducing the imbalance across the center arm created by the ground on one side of the output and the preamplifier connection on the other.

Two parameters which define the quality of the bridge are Directivity and Source Match.

Directivity is a measure of the residual error in the bridge. When the test port is terminated in a perfect matched-impedance load, the detector diode should read zero. However, because of non-symmetry due to resistor imbalances, component placement,

coaxial imbalances, etc., a voltage will be output to the Network Analyzer. The ratio of the detected voltage with a perfect matched-impedance load to the detected voltage with a short is the directivity.

Source Match is a measure of the impedance looking into the test port. It is usually given as SWR. It is a function of the bridge element values, and is independent of directivity: that is, a bridge with very good directivity could have poor source match.

## **A2 Preamplifier Circuit**

The output of the bridge circuit is a low level 27 kHz signal. Before it is input to the Network Analyzer, it must be amplified. This is the function of the preamplifier. Figure 8-3 is a schematic diagram of the preamplifier A2, and Figure 8-2 is a preamplifier component locations diagram.

The functional center of the preamplifier circuit is a low-noise operational amplifier U1 wired in the non-inverting configuration. The gain of the preamplifier is controlled by R3 and R4 ( $\text{Gain} = 1 + R4/R3$ ). The gain may be varied from 1 to approximately 17. R4 is the GAIN adjustment and compensates for the sensitivity of the bridge diode.

The input impedance adjustment R2 (Z) compensates for the internal resistance of the diode. The input impedance may be varied from 100 ohms to approximately 10k ohms.

The 100 ohm resistor R5 and the 1000 pF capacitor C3 form a decoupling network which keeps RF signals from the input of the operational amplifier.

R1 is placed in series with the non-inverting input of the operational amplifier U1 to prevent the input signal from shorting to ground through the 10k potentiometer R2.

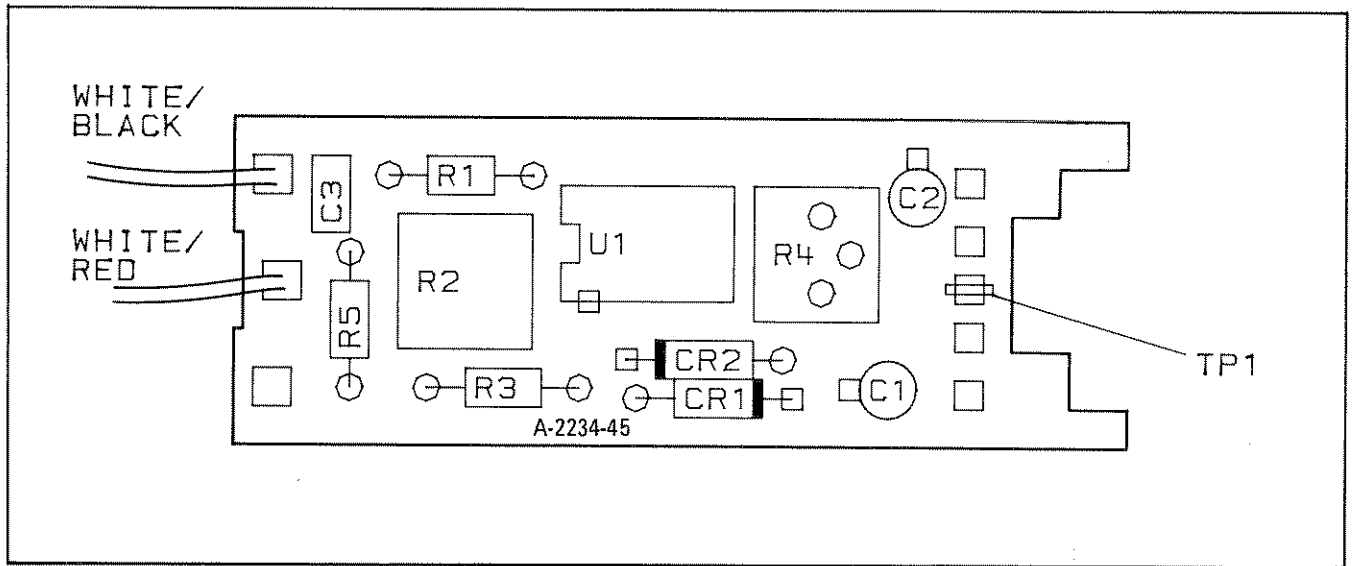

Figure 8-2. A2 Preamplifier Assembly Component Locations

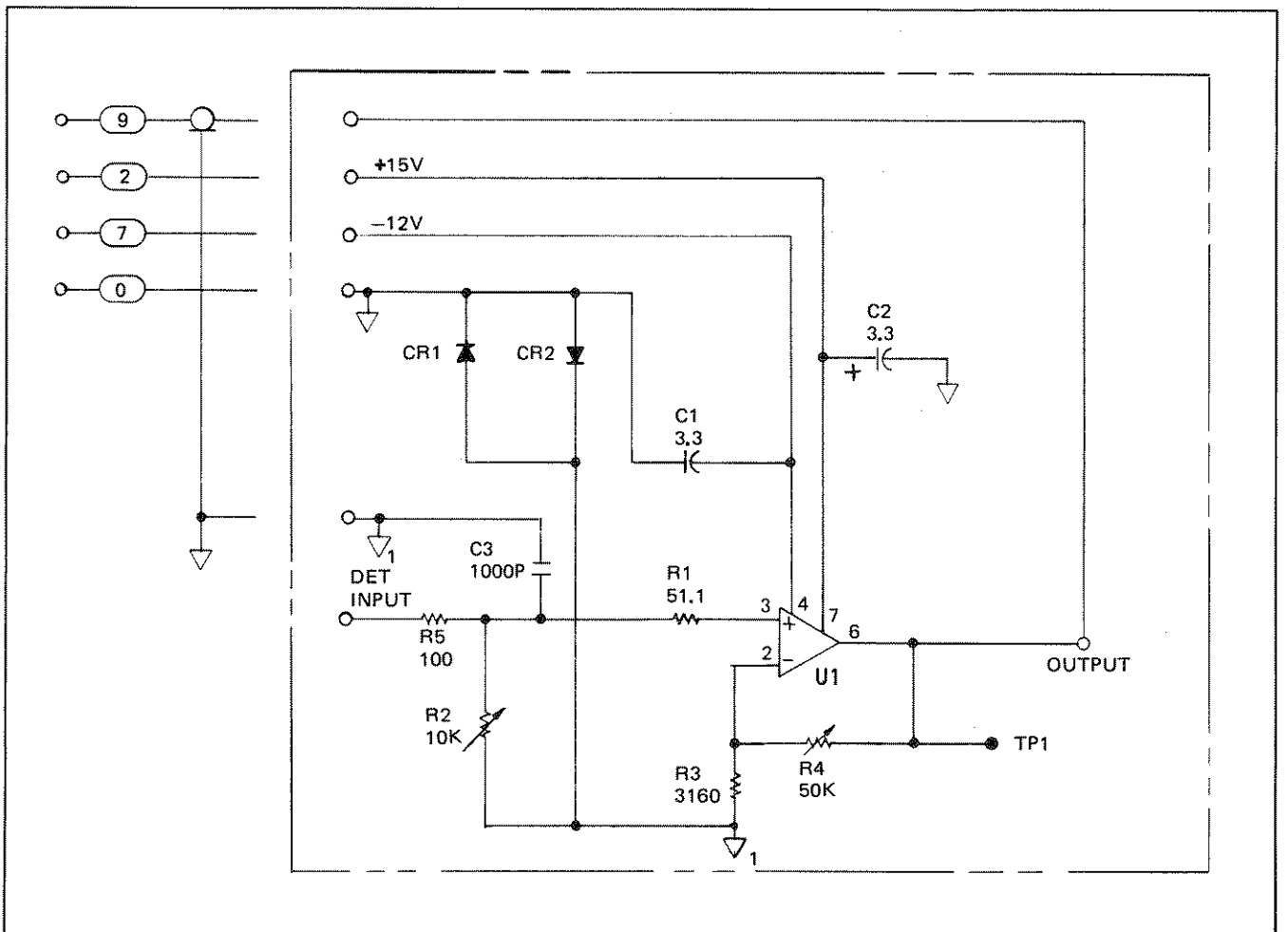

Figure 8-3. A2 Preamplifier Schematic Diagram

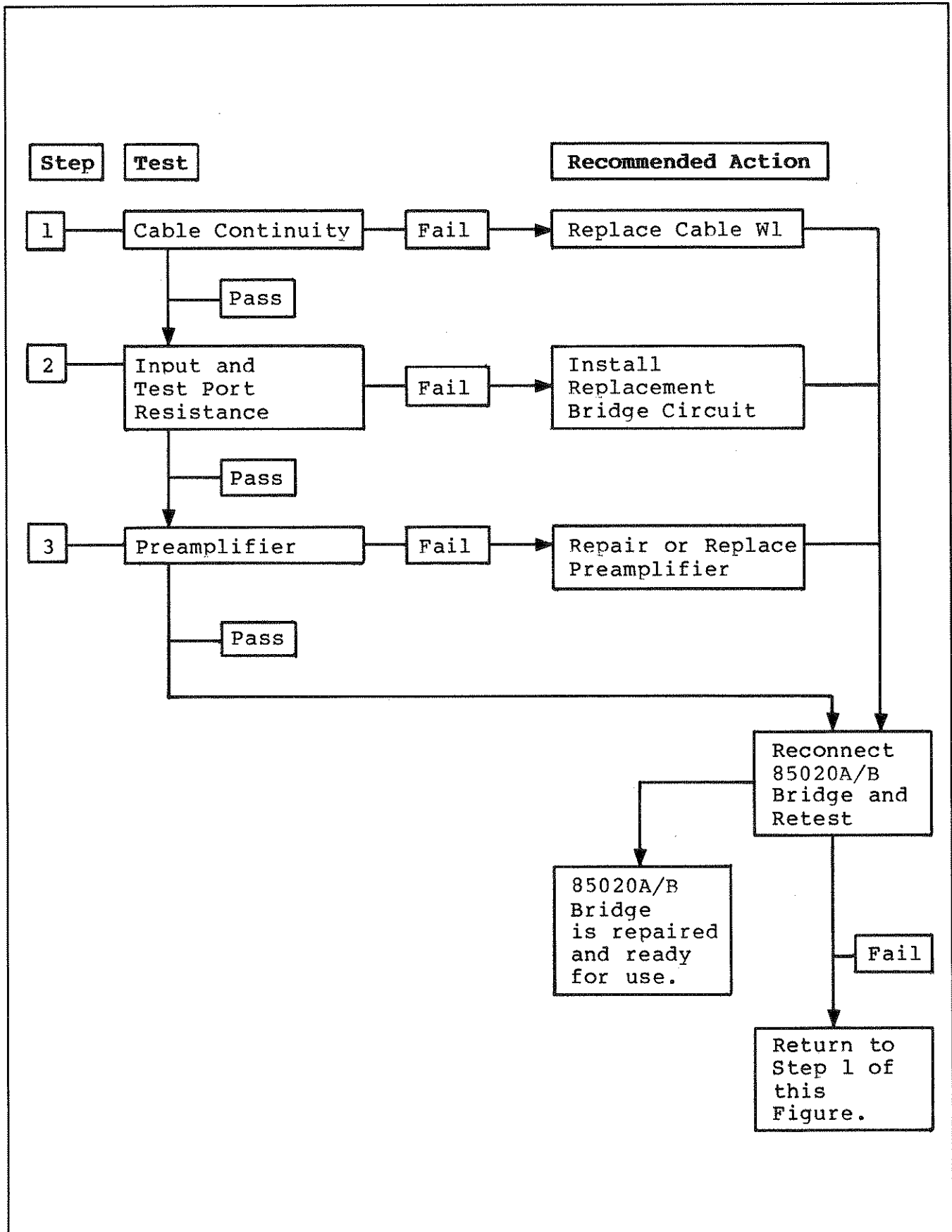

Figure 8-4. Troubleshooting Flow Diagram

## TROUBLESHOOTING PROCEDURES

If a problem persists following the Operator's Check in Section III and the Performance Tests in Section IV, perform the troubleshooting procedures outlined below to isolate the cause and correct the problem. Refer to the troubleshooting flow diagram in Figure 8-4. Instructions for repair or replacement of defective components are provided following the troubleshooting procedures.

### CAUTION

The 85020A/B Directional Bridges contain microcircuits that are highly sensitive to electrostatic discharge (ESD). For service purposes, a work station equipped with an anti-static surface must be used and a grounded wrist strap must be worn. Never touch the center contacts of the connectors with the fingers. Ground the leads of the digital multimeter by touching them to the grounded instrument chassis before making measurements.

### Internal Access

To obtain access to the interior of the 85020A/B for troubleshooting and repair purposes, proceed as follows:

1. Remove the two screws holding the port cover (the test port end plate).
2. Remove the port cover.
3. Slide the top dress cover out of the grey bridge housing. The interior of the 85020A/B is now accessible.

### Cable Continuity Check

1. Use a digital multimeter (DMM) to check the continuity of power cable W1 from the connector pins to the wire connections inside the bridge housing. Table 8-1 lists the W1 connector pins and the corresponding wires.
2. If there are discontinuities in any of the wires replace cable W1, following the instructions outlined under Repair and Replacement Procedures. Repeat the performance tests in Section IV.

Table 8-1. Wires in Power Cable W1

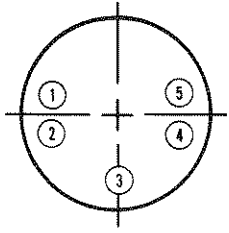
	CONNECTOR PIN	CORRESPONDING WIRE
	1	White (coax center conductor)
	2	Shield (coax outer conductor)
	3	No connection
	4	Violet
	5	Red

### Input Port and Test Port Resistance Checks

1. Ground the leads of the DMM by touching them to the grounded instrument chassis.
2. Measure the resistance from the center contact of input port connector J1 to the center contact of test port connector J2. In the 85020A, the resistance should be 33 ohms  $\pm$  2 ohms. In the 85020B, the resistance should be 46 ohms  $\pm$  2 ohms.
3. Measure the resistance from the center contact of input connector J1 to signal ground (the black/white wire connected to the microcircuit housing). In the 85020A, the resistance should be 83 ohms  $\pm$  2 ohms. In the 85020B, the resistance should be 118 ohms  $\pm$  2 ohms.
4. Measure the resistance from the center contact of test port connector J2 to signal ground. In the 85020A, the resistance should be 83 ohms  $\pm$  2 ohms. In the 85020B, the resistance should be 118 ohms  $\pm$  2 ohms.
5. If the above resistance measurements are not correct, the bridge microcircuit assembly A1 is defective and must be replaced.

#### CAUTION

Do not attempt to disassemble or repair the bridge microcircuit assembly A1, including connectors J1 and J2 and reference termination AT1. Do not remove or loosen any screws on this assembly. Any attempt to perform any disassembly or repair not clearly outlined in this manual will automatically void the warranty.

The bridge microcircuit assembly, including input and test



port connectors and the reference termination, may be replaced on an exchange basis, thus affording a considerable cost savings. Refer to Section VI, Replaceable Parts, of this manual for the part numbers for new and exchange assemblies. The procedures for replacement of the microcircuit and subsequent adjustment of the preamplifier are described below under Repair and Replacement Procedures.

### Preamplifier Check

1. Disconnect the power cable W1 from the Network Analyzer. Unsolder the white/red and white/black wires from the pins on the A1 bridge assembly.
2. Measure the resistance from the input (white/red wire) to signal ground (white/black wire). The resistance should vary from 100 ohms to 10,000 ohms as A2R2 is adjusted through its range.
3. Measure the output resistance, from TP1 to signal ground. The resistance should vary from 3k ohms to 53k ohms as A2R4 is adjusted through its range.
4. Connect the 8756A/8755C MODULATOR DRIVE output center conductor through a 1 Megohm resistor to the 85020A/B A2 preamplifier input (white/red wire). Connect the 8756A/8755C MODULATOR DRIVE output outer conductor to the 85020A/B A2 preamplifier signal ground (white/black wire).
5. Connect the 85020A/B power cable W1 to the A input of the 8756A/8755C.
6. Set the 8756A/8755C channel 1 to display the power level of input A.
7. Erase all memories from any storage device used with the display.
8. Turn A2R2 and A2R4 fully counterclockwise. The 8756A/8755C should display a noise floor of about -50dBm.
9. Turn A2R2 fully clockwise. Adjust A2R4 from one end of its range to the other. The display should change by about 20db.
10. If the preamplifier fails to meet any of the above conditions, replace the defective components. Repeat the performance tests in Section IV.

## REPAIR AND REPLACEMENT PROCEDURES

## Power Cable Replacement

## Preamplifier Assembly Replacement

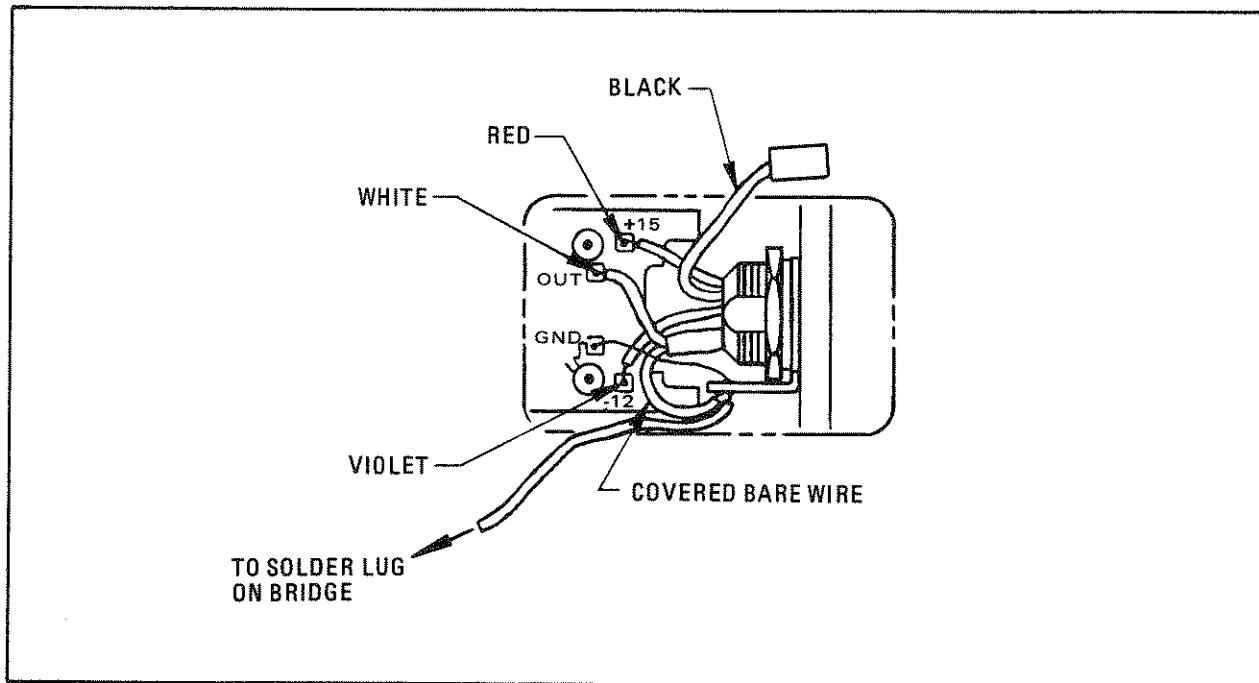

Figure 8-5. Cable to Preamplifier Wiring Diagram

To replace the power cable W1 or the preamplifier assembly A2, proceed as follows:

1. Remove the two screws holding the port cover (test port end plate), and remove the port cover.
2. Slide the top dress cover out of the Bridge frame.
3. Unsolder the wires connected to the power cable/preamplifier assembly.
4. To rewire the power cable, refer to Figure 8-5, Cable to Preamplifier Wiring Diagram.
5. To reconnect the preamplifier A2 to the bridge microcircuit A1, solder the white/black wire to the pad at the top of the preamplifier (the side furthest from the microcircuit). Solder the white/red wire to the middle pad on the preamplifier.

### Replacement of the A1 Bridge Microcircuit Assembly

The bridge microcircuit assembly A1, illustrated in Figure 8-6, includes input port connector J1 and test port connector J2 and reference termination AT1. This assembly may be replaced on an exchange basis at considerable cost savings. Refer to Section VI of this manual for the part numbers for new and exchange assemblies. Since the instrument serial number label must be removed for access to the bridge assembly, each replacement bridge assembly is supplied with a replacement blank serial number label. The instrument serial number should be typed on this label, which is then applied to the instrument following bridge assembly replacement.

#### CAUTION

The 85020A/B Directional Bridge microcircuit is highly sensitive to electrostatic discharge (ESD). For service purposes, a work station equipped with an anti-static surface must be used and a grounded wrist strap must be worn. Never touch the center contacts of the connectors with the fingers.

#### CAUTION

Do not attempt to disassemble or repair the bridge microcircuit assembly A1, including connectors J1 and J2 and reference termination AT1. Do not remove or loosen any screws on this assembly. Any attempt to perform any disassembly or repair not clearly outlined in this section will automatically void the warranty.

To remove the bridge microcircuit assembly A1, proceed as follows:

1. Type the serial number of the 85020A/B Directional Bridge on the rear-panel label supplied with the new or replacement bridge assembly.
2. Remove the two screws holding the port cover (the test port end plate).
3. Remove the port cover.
4. Slide the top dress cover out of the grey 85020A/B Bridge frame.

5. Unsolder the two white/black wires and the white/red wire from the solder lug and connector pins on the A1 bridge housing.
6. Turn over the instrument. Remove the printed mylar serial number label and the aluminum foil cover from the back of the extruded frame. Four screws will be exposed.
7. Remove the four screws from the back of the instrument.
8. Remove the bridge microcircuit from the extruded frame by tilting it up to clear the preamplifier assembly. Take care not to lose the stainless steel spacer under the microcircuit assembly.

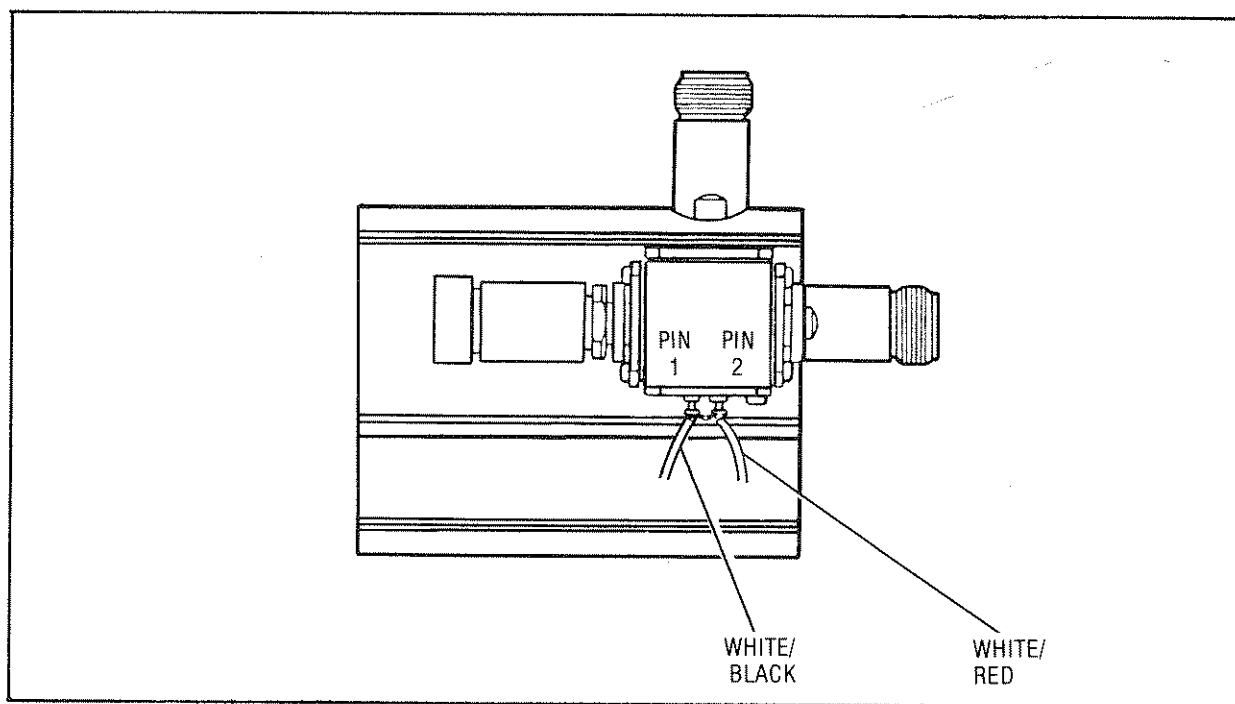

Figure 8-6. A1 Bridge Microcircuit Assembly

To install the replacement bridge assembly, proceed as follows:

1. Install the spacer over the screw holes and the bridge assembly in the instrument frame over the spacer.
2. Replace the four screws.
3. Remove the protective backing from the aluminum foil and apply it to the back of the frame.

4. Remove the protective backing from the new serial number label and apply it over the foil backing.
5. Solder the preamplifier wires back into place. Solder the white/red wire to pin 2 on the bridge housing (see Figure 8-6). Solder the white/black wires to pin 1 and the bottom of the solder lug. Be sure that pin 1 and the solder lug are wired together.
6. Slide the dress cover back into place.
7. Replace the port cover and its screws.
8. Perform the preamplifier adjustment procedure outlined below.

**Preamplifier Adjustment Following Replacement of the Bridge Microcircuit**

Normally no adjustments are required on the 85020A/B Directional Bridges. However, if the internal bridge microcircuit is replaced, the adjustment described here should be performed to compensate the preamplifier for the individual diode characteristics.

**NOTE**

**Allow the equipment to warm up for 30 minutes before performing this adjustment.**

**Description**

The input impedance and gain of the preamplifier assembly are adjusted alternately with the Z and GAIN potentiometers, while the attenuator tracking is observed on the Network Analyzer display.

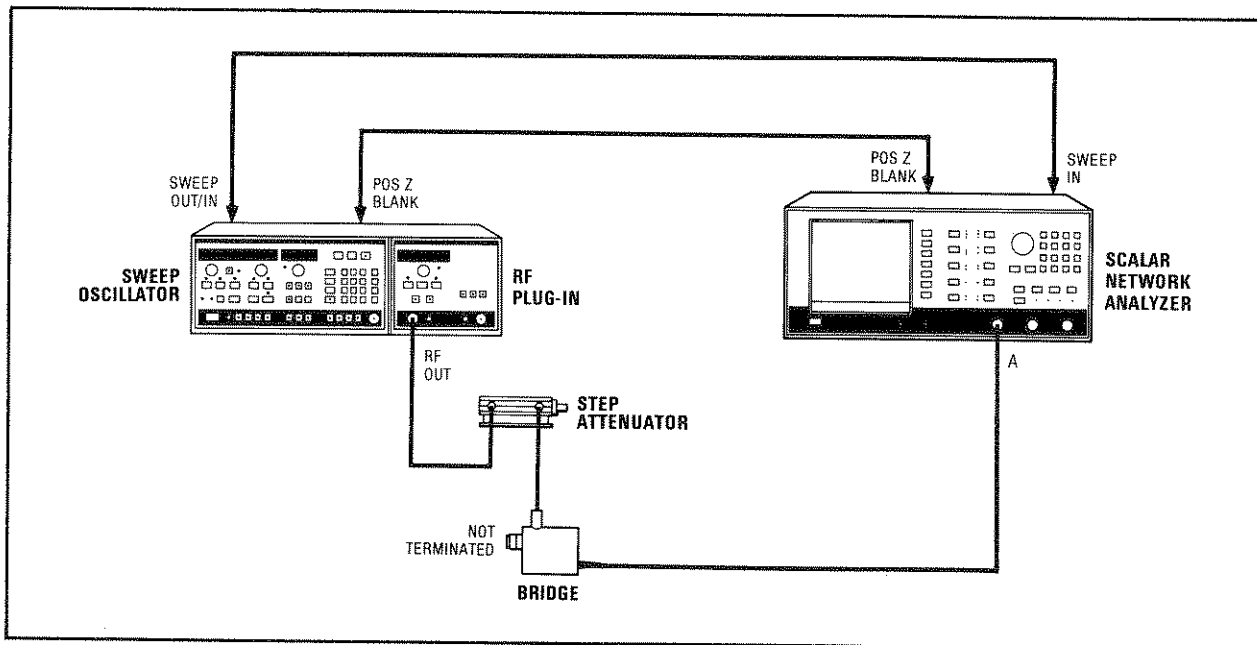

Figure 8-7. Preamplifier Assembly Adjustment Setup

**Equipment**

Scalar Network Analyzer . . . . .	HP 8756A
Sweep Oscillator . . . . .	HP 8350A/B
RF Plug-In . . . . .	HP 83522A/83525A/B
Step Attenuator . . . . .	HP 8495A Opt. 001 (Calibrated)
50-Ohm to 75-Ohm Minimum Loss Pad (85020B only) . . . . .	HP 11852A

**Procedure**

1. Remove the silicone rubber seal from the two potentiometers to gain access to the screwdriver slots.
2. Connect the equipment as shown in Figure 8-7. If the Directional Bridge is an 85020B, connect the Model 11852A 50-ohm to 75-ohm minimum loss pad between the step attenuator and the input port of the Directional Bridge. Allow the equipment to warm up for 30 minutes.
3. On the 8350A/B, press [INSTR PRESET] [SHIFT] [CW] [2] [0] [0] [MHz] to set the signal to swept CW. Press [SWEEP TIME] [1] [5] [0] [ms]. Press [L] MOD to turn on squarewave modulation.
4. Set the 8756A as follows:

```

CHANNEL 2 . . . . . OFF
CHANNEL 1 . . . . . ON
MEAS PWR . . . . . A
REF LEVEL . . . . . 0
SCALE . . . . . 10 dB/DIV
    
```

5. Set the attenuator to 0 dB. Set the REFERENCE POSITION near the top of the screen. Adjust the REFERENCE LEVEL to coincide with the REFERENCE POSITION. (The reference level should be 0 dBm +2 dB with an input signal of +13 dBm, for the 85020A. For the 85020B, the reference level should be -6 dBm +2 dB.)
6. Set the attenuator to 20 dB. On the 85020A/B, adjust A2R2 (Z) to position the trace on the graticule line 20 dB below the reference.
7. Set the attenuator to 0 dB. On the 85020A/B, adjust A2R4 (GAIN) to reposition the trace at the reference.
8. Iterate between the last two steps until the trace is on the graticule line +0.5 dB at both steps.
9. Step the attenuator in 10-dB steps to 40 dB. Check that the traces at all steps are spaced at 10 dB intervals +0.5 dB on the display. If the trace is not tracking at 10-dB intervals, iterate between 0 dB and 40 dB of attenuation while compensating the GAIN and Z adjustments as described above.

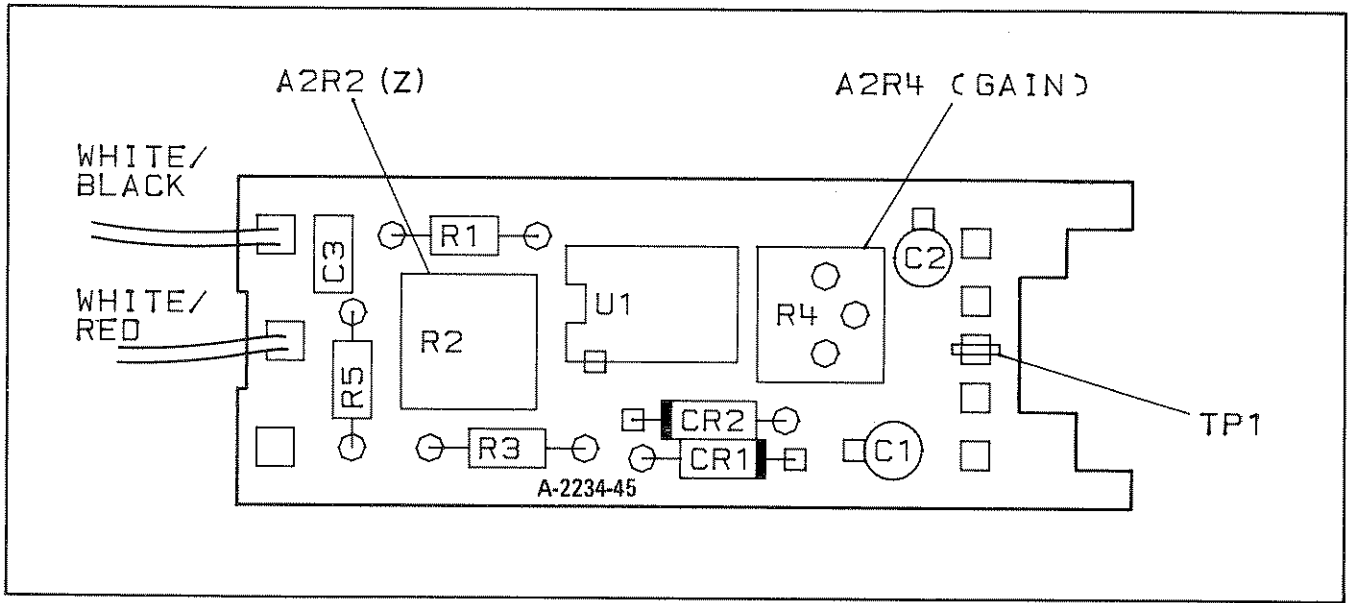

Figure 8-8. Preamplifier Assembly Adjustment Locations





# SALES & SUPPORT OFFICES

## Arranged alphabetically by country

### Product Line Sales/Support Key

- K Key Product Line
- A Analytical
- CM Component
- C Computer Systems Sales only
- CH Computer Systems Hardware Sales and Services
- CS Computer Systems Software Sales and Services
- E Electronic Instruments & Measurement Systems
- M Medical Products
- MP Medical Products Primary SRG
- MS Medical Products Secondary SRG
- P Personal Computer Products
- S Sales only for specific product line
- Support only for specific product line

IMPORTANT: These symbols designate general product line capability. They do not insure sales or support availability for all products within a line, at all locations. Contact your local sales office for information regarding locations where HP support is available for specific products.

HP distributors are printed in italics.

### ANGOLA

*Telectra*  
Empresa Técnica de Equipamentos  
Eléctricos, S.A.R.L.  
R. Barbosa Rodrigues, 411 DT.  
Casa Postal 6487  
LUANDA  
Tel: 35515, 35516  
E.M.P.

### ARGENTINA

Hewlett-Packard Argentina S.A.  
Avenida Santa Fe 2035  
Marine: 1640 BUENOS AIRES  
Tel: 798-5735, 792-1293  
Telex: 17595 BIGNAR  
Cable: HEWPAKARG  
A.C.H./C.S.P.

### AUSTRALIA

**Adelaide, South Australia Office**  
Hewlett-Packard Australia Ltd.  
153 Greenhill Road  
PARKSIDE, S.A. 5063  
Tel: 272-5911  
Cable: HEWPAAD Adelaide  
A.C.H./C.S.E./M.S.P.

**Brisbane, Queensland Office**  
Hewlett-Packard Australia Ltd.  
5th Floor  
Teachers Union Building  
495-499 Boundary Street  
SPRING HILL, Queensland 4000  
Tel: 229-1544  
Telex: 42-1333  
Cable: HEWPAAD Brisbane  
A.C.H./C.S.E./M.S.P.

**Canberra, Australia Capital Territory Office**  
Hewlett-Packard Australia Ltd.  
121 Wollongong Street  
Fyshwick, A.C.T. 2609  
Tel: 80 4244  
Telex: 82650  
Cable: HEWPAAD Canberra  
CH./C.M.E.P.

**Melbourne, Victoria Office**  
Hewlett-Packard Australia Ltd.  
31-41 Joseph Street  
BLACKBURN, Victoria 3130  
Tel: 89-8351  
Telex: 31-024  
Cable: HEWPAAD Melbourne  
A.C.H./C.S.E./M.S.P.

**Perth, Western Australia Office**  
Hewlett-Packard Australia Ltd.  
261 Stirling Highway  
CLAREMONT, W.A. 6010  
Tel: 383-2188  
Telex: 93859  
Cable: HEWPAAD Perth  
A.C.H./C.S.E./M.S.P.

**Sydney, New South Wales Office**  
Hewlett-Packard Australia Ltd.  
17-23 Talavera Road  
P.O. Box 808  
NORTH RYDE, N.S.W. 2113  
Tel: 887-1611  
Telex: 21561  
Cable: HEWPAAD Sydney  
A.C.H./C.S.E./M.S.P.

### AUSTRIA

Hewlett-Packard Ges.m.b.H.  
Grottenhofstrasse 94  
VENAUBURO GRAZ  
A-8050 GRAZ  
Tel: 291-5-66  
Telex: 32375  
CH./C.M.E.

Hewlett-Packard Ges.m.b.H.  
Lithgasse 1  
P.O. Box 72  
A-1222 VIENNA  
Tel: (0222) 23-65-11-0  
Telex: 134425 HEPA A  
A.C.H./C.S.E./M.S.P.

### BELGIUM

Hewlett-Packard Belgium S.A./N.V.  
Blvd de la Woluwe, 100  
Woluwe-la  
B-1200 BRUSSELS  
Tel: (02) 782-32-90  
Telex: 23-494 paloben bru  
A.C.H./C.S.E./M.P.

### BRAZIL

Hewlett-Packard do Brasil I.E. C. Ltda.  
Alameda Rio Negro, 750  
ALPHAVILLE (06400) Barueri SP  
Tel: 421-1311  
Telex: 011 33872 HPBR-BR  
Cable: HEWPAK Sao Paulo  
A.C.H./C.S.E./M.S.

Hewlett-Packard do Brasil I.E. C. Ltda.  
Avenida Epitacio Pessoa, 4664  
22471 RIO DE JANEIRO-RJ  
Tel: 286-0237  
Telex: 92-21905 HPBR BR  
Cable: HEWPAK Rio de Janeiro  
A.C.H./C.S.E./M.S.P.

### CANADA

**Alberta**  
Hewlett-Packard (Canada) Ltd.  
210, 7220 Fisher Street S.E.  
CALGARY, Alberta T2H 2H8  
Tel: (403) 253-2713  
A.C.H./C.M.E.\* M.S.P.\*

Hewlett-Packard (Canada) Ltd.  
11620A-168th Street  
EDMONTON, Alberta T5M 3T9  
Tel: (403) 452-3670  
A.C.H./C.S.E./M.S.P.\*

**British Columbia**  
Hewlett-Packard (Canada) Ltd.  
10691 Sheldridge Way  
RICHMOND, British Columbia V6X 2W7  
Tel: (604) 270-2277  
Telex: 610-922-5059  
A.C.H./C.S.E.\* M.S.P.\*

**Manitoba**  
Hewlett-Packard (Canada) Ltd.  
380-550 Century Street  
WINNIPEG, Manitoba R3H 0Y1  
Tel: (204) 786-6701  
A.C.H./C.S.E.\* M.S.P.\*

**Nov Scotia**  
Hewlett-Packard (Canada) Ltd.  
P.O. Box 931  
903 Windmill Road  
DARTMOUTH, Nova Scotia B2Y 3Z6  
Tel: (902) 459-7820  
Telex: 01931470  
CH./C.S.E.\* M.S.P.\*

**Ontario**  
Hewlett-Packard (Canada) Ltd.  
552 Newbott Street  
LONDON, Ontario N6E 2S5  
Tel: (519) 886-9181  
A.C.H./C.S.E.\* M.S.P.\*

Hewlett-Packard (Canada) Ltd.  
6877 Goreway Drive  
MISSISSAUGA, Ontario L4V 1M8  
Tel: (416) 678-9430  
Telex: 06983644  
A.C.H./C.S.E./M.P.

Hewlett-Packard (Canada) Ltd.  
2670 Queensway Dr.  
OTTAWA, Ontario K2B 8K1  
Tel: (613) 820-6483  
A.C.H./C.S.E.\* M.S.P.\*

**Quebec**  
Hewlett-Packard (Canada) Ltd.  
17500 South Service Road  
Trans-Canada Highway  
KIRKLAND, Quebec H9J 2M5  
Tel: (514) 697-4232  
Telex: 05821521  
A.C.H./C.S.E./M.P.\*

**CHILE**  
Jorge Calcagni y Cia. Ltda.  
Arturo Barrios 065  
Casilla 16475  
SANTAGO 2  
Tel: 22-0222  
Telex: Public Booth 0001  
A.C.M.E.

**CHINA, People's Republic of**  
China Hewlett-Packard Rep. Office  
P.O. Box 418  
14 Lane 2, Luchang St.  
Bowei Rd., Xuanwu District  
BEIJING  
Tel: 33-1947, 33-7426  
Telex: 22601 CTSHP CN  
Cable: 1920  
A.C.H./C.S.E./P.

### COLOMBIA

*Instrumentación*  
H. A. Langebaek & Kier S.A.  
Carrera 7 No. 48-75  
Apartado Aéreo 6287  
BOGOTÁ, D.E.  
Tel: 287-8877  
Telex: 44400 INST CO  
Cable: AARS Bogota  
A.C.M.E./M.P.

**COSTA RICA**  
*Científica Costarricense S.A.*  
Avenida 2, Calle 5  
San Pedro de Montes de Oca  
Apartado 10159  
SAN JOSE  
Tel: 24-38 20, 24-08-19  
Telex: 2367 GALGUR  
C.M.E.M.

### CYPRUS

*Televis Ltd.*  
P.O. Box 4909  
14C Stassinou Avenue  
NICOSIA  
Tel: 62698  
Telex: 2894 Levicody  
E.M.P.

**CZECHOSLOVAKIA**  
Hewlett-Packard  
Ochodni Zastupatelství v CSSR  
Post. schranka 27  
Lida.  
Avenida Epitacio Pessoa, 4664  
22471 RIO DE JANEIRO-RJ  
Tel: 66-296  
Telex: 121353 IHC  
C.M.E.M.

### DENMARK

Hewlett-Packard A/S  
Dallaevj 52  
DK-3460 Birkærd  
Tel: (02) 81 66-40  
Telex: 37409 hpas dk  
A.C.H./C.S.E./M.S.P.

Hewlett-Packard A/S  
Navervej 1  
DK-8600 SILKEBORG  
Tel: (06) 62-71-66  
Telex: 37409 hpas dk  
CH./C.M.E.

### EGYPT

*International Engineering Associates*  
24 Hussein Hegazi Street  
Kasr-El-Ain  
CAIRO  
Tel: 23-829  
Telex: 93830  
CH./C.S.E.M.

**EL SALVADOR**  
*PESA de El Salvador S.A.*  
29 Avenida Norte 1216  
SAN SALVADOR  
Tel: 26-6858, 26-6868  
Telex: Public Booth 20107  
A.C.H./C.S.E./P.

### FINLAND

Hewlett-Packard Oy  
Reinonkallio 7  
SF-02100 ESPOO 10  
Tel: (90) 455-0211  
Telex: 121963 hewpa sf  
A.C.H./C.S.E./M.S.P.

### FRANCE

Hewlett-Packard France  
Z.I. Mercure B  
Rue Berthelot  
F-13763 Les Milles Cedex  
Tel: (42) 59-41-02  
Telex: 410770  
A.C.H./C.S.E./M.S.P.\*

Hewlett-Packard France  
Bureau de Vente de Lyon  
Chemin des Mouilles  
Boite Postale 182  
F-69130 ECULLY Cédex  
Tel: (78) 33-81-25  
Telex: 310617F  
A.C.H./C.S.E./M.P.

Hewlett-Packard France  
Tour Loraine  
Boulevard de France  
F-91035 EVRY Cédex  
Tel: (60) 77-36-60  
Telex: 892315F  
C.M.E.

Hewlett-Packard France  
Centre d'Affaire Paris-Nord  
Bâtiment Ampère 5 étage  
Rue de la Commune de Paris  
Boite Postale 300  
F-93153 LE BLANC MESHUI  
Tel: (01) 855-44-52  
Telex: 211022F  
CH./C.S.E./M.S.

Hewlett-Packard France  
Le Montsequieu  
Avenue du Président JF Kennedy  
F-93700 MERICANQ  
Tel: (58) 34-00-84  
Telex: 550105F  
CH./C.S.E./M.S.

Hewlett-Packard France  
Zone Industrielle de Courtaubouert  
Avenue des Tropiques  
F-91947 Les Ulis Cédex O.N.  
Tel: (6) 907-78-25  
Telex: 800048F  
A.C.H./C.S.E./M.P.

### Hewlett-Packard France

2 Allée de la Bourgonette  
F-35100 RENNES  
Tel: (99) 51-42-44  
Telex: 740912F  
CH./C.S.E./M.S.P.\*

Hewlett-Packard France  
4 Rue Thomas Mann  
106-119 Station Road  
F-67200 STRASBOURG  
Tel: (98) 28-56-46  
Telex: 69014F  
CH./C.S.E./M.S.P.\*

Hewlett-Packard France  
20 Chemin de la Cèprière  
F-31081 TOULOUSE Cédex  
Tel: (61) 40-11-12  
Telex: 531639F  
A.C.H./C.S.E./P.

Hewlett-Packard France  
Immeuble Pélican  
Rue Jean Gogh  
F-69550 VILLENEUVE D'ASO  
Tel: (20) 91-41-25  
Telex: 160124F  
CH./C.S.E./M.P.\*

**GERMAN FEDERAL REPUBLIC**  
Hewlett-Packard GmbH  
Technisches Büro Berlin  
Kellstrasse 2 4  
D-1000 BERLIN 30  
Tel: (030) 24-90-86  
Telex: 018 3495 hpbn d  
A.C.H./C.S.E./M.P.X

Hewlett-Packard GmbH  
Technisches Büro Böblingen  
Herenberger Strasse 110  
D-7030 BOBLINGEN  
Tel: (07031) 667-1  
Telex: tbn or  
A.C.H./C.S.E./M.P.\*

Hewlett-Packard GmbH  
Technisches Büro Düsseldorf  
Emanuel-Louise-Strasse 1  
D-4000 DUSSELDORF  
Tel: (0211) 597-1-1  
Telex: 085/86 533 hpdd d  
A.C.H./C.S.E./M.S.P.

Hewlett-Packard GmbH  
Vertriebszentrale Frankfurt  
Bernier Strasse 117  
Postfach 560 140  
D-6000 FRANKFURT 56  
Tel: (0611) 50-04-1  
Telex: 04 13249 hpdm d  
A.C.H./C.S.E./M.P.\*

Hewlett-Packard GmbH  
Technisches Büro Hamburg  
Kapelstraße 5  
D-2000 HAMBURG 60  
Tel: (040) 63804-1  
Telex: 021 63 032 hpgh d  
A.C.H./C.S.E./M.S.P.

Hewlett-Packard GmbH  
Technisches Büro Hannover  
Am Grossmarkt 6  
D-3000 HANNOVER 91  
Tel: (0511) 46-60-01  
Telex: 092 3259  
A.C.H./C.S.E./M.S.P.

Hewlett-Packard GmbH  
Technisches Büro Mannheim  
Rösselauer Weg 2-4  
D-6800 MANNHEIM  
Tel: (0621) 70050  
Telex: 0462105  
A.C.E.

Hewlett-Packard GmbH  
Technisches Büro Neumünster  
Neumünsterstrasse 90  
D-8500 NEUMÜNSTER  
Tel: (0911) 52 20 83-87  
Telex: 0623 860  
CH./C.M.E./M.S.P.

Hewlett-Packard GmbH  
Technisches Büro München  
Eschenstrasse 5  
D-8028 TAUFKIRCHEN  
Tel: (089) 6117-1  
Telex: 0524995  
A.C.H./C.S.E./M.S.P.

**GREAT BRITAIN**  
Hewlett-Packard Ltd.  
Trafalgar House  
Navigation Road  
Lower Mount Street  
BIRMINGHAM 14 1NU  
Tel: (061) 928-6422  
Telex: 66906B  
A.C.H./C.S.E.M.

Hewlett-Packard Ltd.  
Fountain House  
257-263 High Street  
LONDON COLNEY  
Herts., AL2 1HA, St. Albans  
Tel: (0727) 24400  
Telex: 1-895216  
CH./C.S.E.

Hewlett-Packard Ltd.  
Trax House, St. Mary's Walk  
MAIDENHEAD  
Berks., SL6 1ST  
Tel: (0628) 39 151  
CH./C.S.E.P.

### Hewlett-Packard Italia S.p.A.

Via G. Di Vittorio 9  
I-20065 CERUSSO SUL NAVIGLIO  
Tel: 21 903691  
Telex: 334632  
A.C.H./C.S.E./M.P.P.

Hewlett-Packard Italiana S.p.A.  
Via Nuova san Rocco A  
Capodimonte, 82/A  
I-80131 NAPLES  
Tel: (081) 7413544  
Telex: 170668  
A.C.H./C.M.E.

Hewlett-Packard Italiana S.p.A.  
Viale G. Modugno 33  
I-16156 GENOVA PEGLI  
Tel: (010) 69-37-07  
E.C.

Hewlett-Packard Italiana S.p.A.  
Via Turazza 14  
I-35103 PADOVA  
Tel: (049) 664898  
Telex: 430315  
A.C.H./C.M.E./M.S.

Hewlett-Packard Italiana S.p.A.  
Vale C. Pavese 340  
I-00144 ROMA  
Tel: (06) 54831  
Telex: 610514  
A.C.H./C.S.E./M.S.P.\*

Hewlett-Packard Italiana S.p.A.  
Corso Svizzera, 184  
I-10149 TORINO  
Tel: (011) 74 4044  
Telex: 221079  
CH./C.M.E.

**JAPAN**  
Yokogawa Hewlett-Packard Ltd.  
Inoue Building  
1-21-8, Asahi-cho  
ATSUBU, Kanagawa 243  
Tel: (0462) 28-0451  
DM.C.E.

Yokogawa Hewlett-Packard Ltd.  
Sanjōniya Dai-ichi Semei Bldg  
59 Kyōmachi, Chuo-ku  
KOBE, 650  
Tel: (978) 392-4791  
C.E.

Yokogawa Hewlett-Packard Ltd.  
Asahi Shōwa Dai-ichi Bldg., 2F  
4-7 Hanabishi-cho  
KINOSHITA-SHI, 850  
Tel: (0663) 54-7311  
CH.E.

Yokogawa Hewlett-Packard Ltd.  
Shin Kyoto Center Bldg. 5F  
614 Siokyo-cho  
Nishi-Uchigasaki, Karasuma  
Sickojan, Shimogyo-ku  
KYOTO 600  
Tel: 075 943-0621  
CH.E.

Yokogawa Hewlett-Packard Ltd.  
Mitsubishi Building  
1-4-73, San-no-maru  
MIYAKOJI, 310  
Tel: (0292) 25-7470  
CH./C.M.E.

Yokogawa Hewlett-Packard Ltd.  
Suntomoto Seimei Nagoya Bldg.  
11-2 Shimo-sasayama-cho  
Nakamura-ku  
NAGOYA, Aichi 450  
Tel: (052) 571-5171  
CH./C.S.E./M.S.

Yokogawa Hewlett-Packard Ltd.  
Chuo Bldg., 4th Floor  
5-4-20 Nishinakajima  
Yokogawa-ku  
OSAKA, 532  
Tel: (06) 304-6021  
Telex: YHPD5A 523-3824  
A.C.H./C.S.E./M.P.\*

Yokogawa Hewlett-Packard Ltd.  
Yasodomei Yokohama  
Nishiyoshi Bldg.  
3-304 Tsutsumi-cho  
YOKOHAMA, Kanagawa, 221  
Tel: (045) 312-1252  
CH./C.M.E.

Yokogawa Hewlett-Packard Ltd.  
Yasodomei Yokohama  
Nishiyoshi Bldg.  
3-304 Tsutsumi-cho  
YOKOHAMA, Kanagawa, 221  
Tel: (045) 312-1252  
CH./C.M.E.

**JORDAN**  
Mousher Cousins Company  
P.O. Box 1387  
AMMAN  
Tel: 24907, 29907  
Telex: 21456 SARGO JD  
CH./C.M.P.

### Hewlett-Packard Italia S.p.A.

Via G. Di Vittorio 9  
I-20065 CERUSSO SUL NAVIGLIO  
Tel: 21 903691  
Telex: 334632  
A.C.H./C.S.E./M.P.P.

Hewlett-Packard Italiana S.p.A.  
Via Nuova san Rocco A  
Capodimonte, 82/A  
I-80131 NAPLES  
Tel: (081) 7413544  
Telex: 170668  
A.C.H./C.M.E.

Hewlett-Packard Italiana S.p.A.  
Viale G. Modugno 33  
I-16156 GENOVA PEGLI  
Tel: (010) 69-37-07  
E.C.

Hewlett-Packard Italiana S.p.A.  
Via Turazza 14  
I-35103 PADOVA  
Tel: (049) 664898  
Telex: 430315  
A.C.H./C.M.E./M.S.

Hewlett-Packard Italiana S.p.A.  
Vale C. Pavese 340  
I-00144 ROMA  
Tel: (06) 54831  
Telex: 610514  
A.C.H./C.S.E./M.S.P.\*

Hewlett-Packard Italiana S.p.A.  
Corso Svizzera, 184  
I-10149 TORINO  
Tel: (011) 74 4044  
Telex: 221079  
CH./C.M.E.

**JAPAN**  
Yokogawa Hewlett-Packard Ltd.  
Inoue Building  
1-21-8, Asahi-cho  
ATSUBU, Kanagawa 243  
Tel: (0462) 28-0451  
DM.C.E.

Yokogawa Hewlett-Packard Ltd.  
Sanjōniya Dai-ichi Semei Bldg  
59 Kyōmachi, Chuo-ku  
KOBE, 650  
Tel: (978) 392-4791  
C.E.

Yokogawa Hewlett-Packard Ltd.  
Asahi Shōwa Dai-ichi Bldg., 2F  
4-7 Hanabishi-cho  
KINOSHITA-SHI, 850  
Tel: (0663) 54-7311  
CH.E.

Yokogawa Hewlett-Packard Ltd.  
Shin Kyoto Center Bldg. 5F  
614 Siokyo-cho  
Nishi-Uchigasaki, Karasuma  
Sickojan, Shimogyo-ku  
KYOTO 600  
Tel: 075 943-0621  
CH.E.

Yokogawa Hewlett-Packard Ltd.  
Mitsubishi Building  
1-4-73, San-no-maru  
MIYAKOJI, 310  
Tel: (0292) 25-7470  
CH./C.M.E.

Yokogawa Hewlett-Packard Ltd.  
Suntomoto Seimei Nagoya Bldg.  
11-2 Shimo-sasayama-cho  
Nakamura-ku  
NAGOYA, Aichi 450  
Tel: (052) 571-5171  
CH./C.S.E./M.S.

Yokogawa Hewlett-Packard Ltd.  
Chuo Bldg., 4th Floor  
5-4-20 Nishinakajima  
Yokogawa-ku  
OSAKA, 532  
Tel: (06) 304-6021  
Telex: YHPD5A 523-3824  
A.C.H./C.S.E./M.P.\*

Yokogawa Hewlett-Packard Ltd.  
Yasodomei Yokohama  
Nishiyoshi Bldg.  
3-304 Tsutsumi-cho  
YOKOHAMA, Kanagawa, 221  
Tel: (045) 312-1252  
CH./C.M.E.

Yokogawa Hewlett-Packard Ltd.  
Yasodomei Yokohama  
Nishiyoshi Bldg.  
3-304 Tsutsumi-cho  
YOKOHAMA, Kanagawa, 221  
Tel: (045) 312-1252  
CH./C.M.E.

**JORDAN**  
Mousher Cousins Company  
P.O. Box 1387  
AMMAN  
Tel: 24907, 29907  
Telex: 21456 SARGO JD  
CH./C.M.P.

### KENYA

ADCOM Ltd., Inc.  
City House, Wabera Street  
P.O. Box 30639  
NAIROBI  
Tel: 331955  
Telex: 22639  
E.M.

**KOREA**  
Samsung Electronics Computer  
Division  
76-561 Yongsam-Dong  
Kangnam-Ku  
C.P.O. Box 2775  
SEOUL  
Tel: 555-7555, 555-5447  
Telex: K27394 SAMSAN  
A.C.H./C.S.E./M.P.

**KUWAIT**  
Al-Khaldiya Trading & Contracting  
P.O. Box 630 Safat  
KUWAIT  
Tel: (049) 664898  
Telex: 42-4910, 41-1726  
Telex: 2481 Areeg kt  
CH./C.M.

**LUXEMBOURG**  
Hewlett-Packard Belgium S.A./N.V.  
Blvd de la Woluwe, 100  
Woluwe-la  
D-1200 BRUSSELS  
Tel: (02) 762-32-00  
Telex: 23-494 paloben bru  
A.C.H./C.S.E./M.P.

**MALAYSIA**  
Hewlett-Packard (Malaysia)  
Sdn Bhd  
1st Floor, Bangunan British  
American  
Jalan Semantan, Damansara Heights  
KUALA LUMPUR 23-03  
Tel: (03) 43022  
Telex: MA31011  
A.C.H./C.M.E.\*

*Protel Engineering*  
Lot 319, Satok Road  
P.O. Box 1917  
Kuching, SARAWAK  
Tel: 53544  
Telex: MA 70904 PRGMAL  
Cable: PROTELENG  
A.E.M.

**MEXICO**  
Hewlett-Packard Mexicana, S.A. de  
C.V.  
Av. Periferico Sur No. 8501  
Tepic, Jalisco, Coahuila 16020  
MEXICO CITY  
Tel: (955) 676-4600  
Telex: 017-74-507  
A.C.H./C.S.E./M.S.P.

**MOROCCO**  
Dobbeau  
81 Rue Karach  
CASABLANCA  
Tel: 304-82, 3069-38  
Telex: 23051, 22822  
E

**NETHERLANDS**  
Hewlett-Packard Nederland B.V.  
Van Heuren Goedhartlaan 121  
NL 1181KX AMSTELVEEN  
P.O. Box



# SALES & SUPPORT OFFICES

## Arranged alphabetically by country (cont.)

### PANAMA

**Electrónica Balboa, S.A.**  
Calle Samuel Lewis, Ed. Alfa  
Apartado 4929  
**PANAMA 4**  
Tel: 64-2700  
Telex: 3438 ELECTRON PG  
A.CH.M.C.S.E.M.P

### PERU

**Co Electro Médica S.A.**  
Los Flamencos 145, San Isidro  
Castillo 1030  
**LIMA 1**  
Tel: 41-4325, 41-3703  
Telex: Pub. Booth 25306  
A.C.M.E.M.P

### PHILIPPINES

**The Online Advanced Systems Corporation**  
Rico House, Amorsolo Cor. Henera Street  
Legaspi Village, Makati  
P.O. Box 1510  
**Metro MANILA**  
Tel: 85-35-81, 85-34-91, 85-32-21  
Telex: 3274 ONLINE  
A.CH.CS.E.M

### POLAND

**Buro Inzynierski Technicznej Hewlett-Packard**  
Ul. Stawki 2, GP  
PLD-950 WARSZAWA  
Tel: 59-59-62, 39-67-43  
Telex: 812453 hepa pl  
CH.CS.E.P

### PORTUGAL

**Telectra-Empresa Técnica de Equipamentos Eléctricos S.A. L.**  
Rua Rodrigo da Fonseca 100  
P.O. Box 2531  
**P-LISBOA 1**  
Tel: (91) 68-60-72  
Telex: 12598  
CH.CS.E.P

### ROMANIA

**Hewlett-Packard Reprezentanta**  
Boulevard Nicolae Balcescu 16  
**BUCURESTI**  
Tel: 130725  
Telex: 10440

### SAUDI ARABIA

**Modern Electronic Establishment**  
P.O. Box 193  
**AL-KHOBAR**  
Tel: 670136  
Cable: ELECTA AL-KHOBAR  
CH.CS.E.M.P

### Modern Electronic Establishment

P.O. Box 1228, Bagdadiah Street  
**JEDDAH**  
Tel: 642-0229  
Telex: 401035  
Cable: ELECTA JEDDAH  
CH.CS.E.M.P

### Modern Electronic Establishment

P.O. Box 2728  
**RIYADH**  
Tel: 491-9715, 491-6387  
Telex: 200756  
CH.CS.E.M.P

### SCOTLAND

Hewlett-Packard Ltd  
**SOUTH QUEENSFERRY**  
West Lothian, EH30 9GT  
GB-Scotland  
Tel: (031) 3311188  
Telex: 72682  
A.CH.M.C.S.E.M

### SINGAPORE

Hewlett-Packard Singapore (Pty.) Ltd  
P.O. Box 58 Alexandra Post Office  
**SINGAPORE 9, 115**  
8th Floor, Indragage House  
450-452 Alexandra Road  
**SINGAPORE 05111**  
Tel: 631788  
Telex: HPSG30 RS 34209  
Cable: HEWPACK, Singapore  
A.CH.CS.E.M.S.P

### SOUTH AFRICA

Hewlett-Packard South Africa (Pty.) Ltd  
P.O. Box 920  
Howard Place  
Pine Park Center, Forest Drive, Pinelands  
**CAPE PROVINCE 7450**  
Tel: 53-7955, 53-7956, 53-7957  
Telex: 57-20006  
A.CH.M.C.S.E.M.P  
Hewlett-Packard South Africa (Pty.) Ltd  
P.O. Box 33345  
Glenstantia 0010 **TRANSVAAL**  
1st Floor East  
Constatia Park Ridge Shopping Centre  
Constatia Park  
**PRETORIA**  
Tel: 982043  
Telex: 32163  
CH.E  
Hewlett-Packard South Africa (Pty.) Ltd  
Private Bag Wendywood  
**SANDTON 2144**  
Tel: 802-5111, 802-5125  
Telex: 4-20877  
Cable: HEWPACK Johannesburg  
A.CH.M.C.S.E.M.S.P

### SPAIN

Hewlett-Packard Española S.A.  
c/Enxeta, 321  
**E-BARCELONA 29**  
Tel: (3) 322-24 51, 321-73 54  
Telex: 52603 hpbce  
A.CH.M.C.S.E.M.S.P

### Hewlett-Packard Española S.A.

c/San Vicente SAN  
Edificio Alba 3, 7 B  
**E-BILBAO 1**  
Tel: (4) 23-8306, (4) 23-8206  
A.CH.M.C.S.E.M.S  
Hewlett-Packard Española S.A.  
Calle Jerez 3  
**E-MADRID 16**  
Tel: (1) 458-2600  
Telex: 23515 hpe  
A.C.M.E.

### SWEDEN

Hewlett-Packard (Schweiz) AG  
Skalmottsgatan 9, Kista  
Box 19  
S-16393 **SPANGA**  
Tel: (08) 750-2000  
Telex: 854-10721  
A.CH.M.C.S.E.M.S.P  
Hewlett-Packard Sverige AB  
Fristallsgatan 30  
S-42132 **VASTRA-FROLUNDA**  
Tel: (031) 40-69-50  
Telex: (854) 10721 (via SPANGA office)  
CH.CM.E.P

### SWITZERLAND

Hewlett-Packard (Schweiz) AG  
29 Chemin Château Bloc  
CH-1219 LE LIGNON-Geneva  
Tel: (022) 98-93-22  
Telex: 21333 hpag ch  
Cable: HEWPACKAG Geneva  
A.CH.M.C.S.E.M.S.P  
Hewlett-Packard (Schweiz) AG  
Almend 7  
CH-8967 **WIDEN**  
Tel: (57) 50-111  
Telex: 59933 hpag ch  
A.CH.M.C.S.E.M.S.P

### SYRIA

**General Electronic Inc**  
Nun Basma-Anhal Ebn Kays Street  
P.O. Box 5781  
**DAMASCUS**  
Tel: 33-24-87  
Cable: ELECTROBOR DAMASCUS  
E

### TAIWAN

Hewlett-Packard Far East Ltd.  
Taiwan Branch  
5th Floor  
205 Tun Hwa North Road  
**TAIPEI**  
Tel: (02) 751-0404  
Cable: HEWPACK, Taipei  
A.CH.M.C.S.E.M.P

### THAILAND

**Unimesa**  
30 Patpong Ave., Suriwong  
**BANGKOK 5**  
Tel: 234 091, 234 092  
Telex: 84439 SIMANCA TH  
Cable: UNIMESA Bangkok  
A.C.E.M.

### TRINIDAD & TOBAGO

**Caribbean Telecom Ltd**  
5314 Jamnigam Avenue  
P.O. Box 732  
**PORT-OF-SPAIN**  
Tel: 62-44213, 62-44214  
Telex: 235,272 HUSCO WG  
A.C.M.E.M.P

### TUNISIA

**Tunisise Electronique**  
31 Avenue de la Liberté  
**TUNIS**  
Tel: 280-144  
E

### TURKEY

**Tekim Company Ltd**  
Iran Caddesi No. 7  
Kavakliders, **ANKARA**  
Tel: 275800  
Telex: 42155  
E

### UNITED ARAB EMIRATES

**Emilat Ltd.**  
P.O. Box 1641  
**SHARJAH**  
Tel: 354121, 354123  
Telex: 68139 Emilat Sh  
CH.CS.E.M.P

### UNITED KINGDOM

see: GREAT BRITAIN

### SCOTLAND

### UNITED STATES

#### Alabama

Hewlett-Packard Co.  
P.O. Box 4207  
8250 Whimsburg Drive, S.E.  
**HUNTSVILLE AL 35892**  
Tel: (205) 981-4591  
CH.CM.CS.E.M\*

#### Arizona

Hewlett-Packard Co.  
2336 East Magnolia Street  
**PHOENIX, AZ 85034**  
Tel: (602) 273-8000  
A.CH.M.C.S.E.M.S  
Hewlett-Packard Co.  
2424 East Aragon Road  
**TUCSON, AZ 85706**  
Tel: (602) 889-4631  
CH.E.M.S.\*\*

#### California

Hewlett-Packard Co.  
7821 Canoga Avenue  
**CANOGA PARK, CA 91304**  
Tel: (213) 702-8300  
A.CH.CS.E.P  
Hewlett-Packard Co.  
1430 East Orangehorpe  
**FULLERTON, CA 92631**  
Tel: (714) 870-1000  
CH.M.CS.E.M.P  
Hewlett-Packard Co.  
3939 Lankershim Blvd  
**NORTH HOLLYWOOD, CA 91604**  
Tel: (213) 877-1282  
Regional Headquarters  
Hewlett-Packard Co.  
3200 Hillview Avenue  
**PALO ALTO, CA 94304**  
Tel: (415) 857-8000  
CH.CS.E.

#### Massachusetts

Hewlett-Packard Co.  
646 W. North Market Boulevard  
**SACRAMENTO, CA 95834**  
Tel: (916) 939-7222  
A.CH.CS.E.M.S  
Hewlett-Packard Co.  
8906 Aero Drive  
P.O. Box 24333 **SAN DIEGO, CA 92123**  
Tel: (714) 270-3200  
CH.M.CS.E.M.P

#### Hewlett-Packard Co.

3003 Scott Boulevard  
**SANTA CLARA, CA 95050**  
Tel: (408) 988-7000  
A.CH.M.CS.E.M.P

#### Colorado

Hewlett-Packard Co.  
24 Inverness Place, East  
**ENGLEWOOD, CO 80112**  
Tel: (303) 771-3455  
A.CH.M.CS.E.M.S

#### Connecticut

Hewlett-Packard Co.  
47 Barnes Industrial Road South  
P.O. Box 5007  
**WALLINGFORD, CT 06402**  
Tel: (203) 265-7901  
A.CH.M.CS.E.M.S

#### Florida

Hewlett-Packard Co.  
P.O. Box 24210  
2901 N.W. 62nd Street  
**FORT LAUDERDALE, FL 33307**  
Tel: (305) 973-2800  
CH.CS.E.M.P  
Hewlett-Packard Co.  
4080 Woodcock Drive, #132  
Brownell Building  
**JACKSONVILLE, FL 32207**  
Tel: (904) 399-0663  
C.E.M.S.\*\*

#### Hewlett-Packard Co.

P.O. Box 13910  
6177 Lake Ellenor Drive  
**ORLANDO, FL 32809**  
Tel: (305) 859-2900  
A.CH.M.CS.E.M.S

#### Hewlett-Packard Co.

5750 North Hoover, Suite 123  
**TAMPA, FL 33614**  
Tel: (813) 872-9000  
A.CH.M.CS.E.M\*  
**Georgia**  
Hewlett-Packard Co.  
P.O. Box 105005  
**ATLANTA, GA 30308**  
2000 South Park Place  
**ATLANTA, GA 30338**  
Tel: (404) 955-1500  
Telex: 810-766-4890  
A.CH.M.CS.E.M.P

#### Hewlett-Packard Co.

Hewlett-Packard Co.  
P.O. Box 2103  
**WARNER ROBINS, GA 31099**  
1172 N. Davis Drive  
**WARNER ROBINS, GA 31093**  
Tel: (912) 923-8831  
E

#### Hawaii

Hewlett-Packard Co.  
Kawaiahaeo Plaza, Suite 190  
567 South King Street  
**HONOLULU, HI 96813**  
Tel: (808) 526-1555  
A.CH.E.M.S

#### Illinois

Hewlett-Packard Co.  
5201 Tolliver Drive  
**ROLLING MEADOWS, IL 60008**  
Tel: (312) 255-9800  
A.CH.M.CS.E.M.P

#### Indiana

Hewlett-Packard Co.  
P.O. Box 50807  
7301 No. Shadeland Avenue  
**INDIANAPOLIS, IN 46250**  
Tel: (317) 842-1000  
A.CH.M.CS.E.M.S

#### Iowa

Hewlett-Packard Co.  
2015 Heinz Road  
**IAWA CITY, IA 52240**  
Tel: (319) 351-1020, 366-6477  
CH.E.M.S

#### Louisiana

Hewlett-Packard Co.  
P.O. Box 1449  
**Kenner, LA 70062**  
160 James Drive East  
**DESTAHAN, LA 70047**  
Tel: (504) 467-4100  
A.CH.CS.E.M.S

#### Maryland

Hewlett-Packard Co.  
7121 Standard Drive  
**HANOVER, MD 21076**  
Tel: (301) 796-7700  
A.CH.M.CS.E.M.S  
Hewlett-Packard Co.  
2 Choke Cherry Road  
**ROCKVILLE, MD 20850**  
Tel: (301) 948-6370  
Telex: 710-828-9685  
A.CH.M.CS.E.M.P

#### Massachusetts

Hewlett-Packard Co.  
32 Hartwell Avenue  
**LEXINGTON, MA 02173**  
Tel: (617) 861-8960  
A.CH.M.CS.E.M.P  
**Michigan**  
Hewlett-Packard Co.  
23855 Research Drive  
**FARMINGTON HILLS, MI 48024**  
Tel: (313) 476-6400  
A.CH.M.CS.E.M.P

#### Minnesota

Hewlett-Packard Co.  
2025 W. Larpenteur Ave.  
**ST. PAUL, MN 55113**  
Tel: (612) 544-1700  
A.CH.M.CS.E.M.P

#### Missouri

Hewlett-Packard Co.  
11131 Colorado Avenue  
**KANSAS CITY, MO 64137**  
Tel: (816) 763-8000  
Telex: 910-771-2067  
A.CH.M.CS.E.M.S  
Hewlett-Packard Co.  
1024 Executive Parkway  
**ST. LOUIS, MO 63141**  
Tel: (314) 878-0200  
A.CH.CS.E.M.P

#### New Jersey

Hewlett-Packard Co.  
Crystal Brook Professional Building  
Route 35  
**EATONTOWN, NJ 07724**  
Tel: (201) 542-1384  
A.C.E.P.  
Hewlett-Packard Co.  
W120 Century Road  
**PARAMUS, NJ 07652**  
Tel: (201) 285-5000  
A.CH.M.CS.E.M.P

#### Hewlett-Packard Co.

60 New England Av. West  
**PISCATAWAY, NJ 08854**  
Tel: (201) 981-1199  
A.CH.M.CS.E

#### New Mexico

Hewlett-Packard Co.  
P.O. Box 11834  
**ALBUQUERQUE, NM 87112**  
11300 Lomas Blvd., N.E.  
**ALBUQUERQUE, NM 87123**  
Tel: (505) 292-1330  
Telex: 910-989-1185  
CH.CS.E.M.S

#### New York

Hewlett-Packard Co.  
5 Computer Drive South  
**ALBANY, NY 12205**  
Tel: (518) 458-1550  
Telex: 710-444-4691  
A.CH.E.M.S  
Hewlett-Packard Co.  
200 Cross Keys Office  
**FAIRPORT, NY 14450**  
Tel: (716) 223-9950  
Telex: 510-253-0092  
CH.M.CS.E.M.S

#### Hewlett-Packard Co.

7841 Henry Clay Blvd  
**LIVERPOOL, NY 13088**  
Tel: (315) 451-1820  
A.CH.M.CS.E.M.S  
Hewlett-Packard Co.  
No. 1 Pennsylvania Plaza  
55th Floor  
34th Street & 8th Avenue  
**NEW YORK, NY 10119**  
Tel: (212) 971-0900  
CH.CS.E.M\*

#### Hewlett-Packard Co.

3 Crossways Park West  
**WOODBURY, NY 11797**  
Tel: (516) 921-0300  
Telex: 510-221-2183  
A.CH.M.CS.E.M.S

#### Hewlett-Packard Co.

16500 Sprague Road  
**CLEVELAND, OH 44130**  
Tel: (216) 423-7300  
Telex: 810-423-9430  
A.CH.M.CS.E.M.S

#### Hewlett-Packard Co.

962 Crupper Ave.  
**COLUMBUS, OH 43229**  
Tel: (614) 498-1041  
CH.M.CS.E.\*  
Hewlett-Packard Co.  
P.O. Box 280  
330 Progress Rd.  
**DAYTON, OH 45449**  
Tel: (513) 859-8202  
A.CH.M.CS.E.M.S  
**Oklahoma**  
Hewlett-Packard Co.  
P.O. Box 280  
330 Progress Rd.  
**DAYTON, OH 45449**  
Tel: (513) 859-8202  
A.CH.M.CS.E.M.S  
**Oklahoma City, OK 73107**  
Tel: (405) 946-9499  
A.CH.E.M.S  
**Oregon**  
Hewlett-Packard Co.  
9255 S. W. Pioneer Court  
**WILSONVILLE, OR 97070**  
Tel: (503) 682-8000  
A.CH.CS.E.M.S  
**Pennsylvania**  
Hewlett-Packard Co.  
1021 Bth Avenue  
King of Prussia Industrial Park  
**KING OF PRUSSIA, PA 19406**  
Tel: (215) 265-7000  
A.CH.M.CS.E.M.P  
Hewlett-Packard Co.  
111 Zela Drive  
**PITTSBURGH, PA 15238**  
Tel: (412) 782-0400  
A.CH.CS.E.M.P  
**South Carolina**  
Hewlett-Packard Co.  
1 Hartison Way  
**COLUMBIA, SC 29210**  
Tel: (803) 732-0400  
CH.E.M.S  
**Texas**  
Hewlett-Packard Co.  
Suite 310W  
7800 Shoal creek Blvd.  
**AUSTIN, TX 78757**  
Tel: (512) 459-3143  
E  
Hewlett-Packard Co.  
Suite C-110  
4171 North Mesa  
**EL PASO, TX 79902**  
Tel: (915) 533-3555, 533-4469  
CH.E.M.S\*\*  
Hewlett-Packard Co.  
P.O. Box 42816  
**HOUSTON, TX 77042**  
10535 Harwin Street  
**HOUSTON, TX 77036**  
Tel: (713) 776-6400  
A.CH.M.CS.E.M.P  
Hewlett-Packard Co.  
P.O. Box 1270  
**RICHARDSON, TX 75080**  
930 E. Campbell Rd  
**RICHARDSON, TX 75081**  
Tel: (214) 231-6101  
A.CH.M.CS.E.M.P  
Hewlett-Packard Co.  
P.O. Box 32993  
**SAN ANTONIO, TX 78216**  
1000 Central Parkway, South  
**SAN ANTONIO, TX 78232**  
Tel: (512) 494-9338  
CH.CS.E.M.S  
**Utah**  
Hewlett-Packard Co.  
P.O. Box 26926  
3530 W. 2100 South  
**SALT LAKE CITY, UT 84119**  
Tel: (801) 974-1700  
A.CH.CS.E.M.S  
**Virginia**  
Hewlett-Packard Co.  
P.O. Box 9660  
2914 Hungary Spring Road  
**RICHMOND, VA 23228**  
Tel: (804) 285-3431  
A.CH.CS.E.M.S  
Hewlett-Packard Co.  
3106 Peters Creek Road, N.W.  
**ROANOKE, VA 24019**  
Tel: (703) 563-2205  
CH.E.M\*\*

#### Washington

Hewlett-Packard Co.  
15815 S.E. 37th Street  
**BELLEVUE, WA 98006**  
Tel: (206) 643-4000  
A.CH.M.CS.E.M.P

#### Wisconsin

Hewlett-Packard Co.  
150 S. Sunny Slope Road  
**BROOKFIELD, WI 53005**  
Tel: (414) 784-8800  
A.CH.CS.E.M.P

#### URUGUAY

**Pablo Ferrando S.A.C. e.I.**  
Avenida Italia 2877  
Casilla de Correo 370  
**MONTEVIDEO**  
Tel: 80.2586  
Telex: Public Booth 901  
A.C.M.E.M.

#### U.S.S.R.

Hewlett-Packard Co.  
Representative Office  
Pokrovsky Blvd., 4/17 KV12  
**MOSCOW 101000** Tel: 294-2024  
Telex: 7625 HEWPACK SU

#### VENEZUELA

Hewlett-Packard S.A.  
4 Choke Cherry Road  
Rockville, MD 20850  
Tel: (301) 258-2000  
A.CH.CS.E.M.S

#### ASIA

Hewlett-Packard Asia Ltd.  
8th Floor, Sun Hung Kai Center  
30 Harbor Rd.  
G.P.O. Box 795  
**HONG KONG**  
Tel: 5-832 3211  
Cable: 86678 HEWPA HK  
Hewlett-Packard Asia Ltd  
Hong Kong  
Tel: (272) 235 hpsc  
Cable: HEWPACKSA Geneva

#### ASIA

Hewlett-Packard (Canada) Ltd.  
6877 Goreway Drive  
**MISSISSAUGA, Ontario L4V 1M6**  
Tel: (416) 678-9430  
Telex: 610-492-4246

#### CANADA

Hewlett-Packard (Canada) Ltd.  
6877 Goreway Drive  
**MISSISSAUGA, Ontario L4V 1M6**  
Tel: (416) 678-9430  
Telex: 610-492-4246

#### EASTERN EUROPE

Hewlett-Packard Ges.m.b.H.  
Wehrstrasse 29  
P.O. Box 7  
A-1205 VIENNA  
Tel: (0222) 35-16-210  
Telex: 35623/135066

#### NORTHERN EUROPE

Hewlett-Packard S.A.  
Ullensstede 175  
NL-1183 AG AMSTELVEEN  
The Netherlands  
P.O. Box 999  
NL-1180 AZ AMSTELVEEN  
The Netherlands  
Tel: 20 437771

#### OTHER EUROPEAN

Hewlett-Packard S.A.  
7 Rue du Bois-du-Lan  
CH-1217 MEYRIN 2, Switzerland  
Tel: (022) 96-96-51  
Telex: 27635 hpsc  
Cable: HEWPACKSA Geneva  
(Offices in the World Trade Center)

#### MEDITERRANEAN AND MIDDLE EAST

Hewlett-Packard S.A.  
Mediterranean and Middle East  
Operations  
Africa Centre  
32 Killias Avenue  
**AMAROUSSE, ATHENS, Greece**  
Tel: 803-0359 808-0429  
Telex: 21-6588  
Cable: HEWPACKSA Athens

#### YUGOSLAVIA