

# OPERATING AND SERVICE MANUAL

## HP 83594A RF PLUG-IN 2.0 to 26.5 GHz

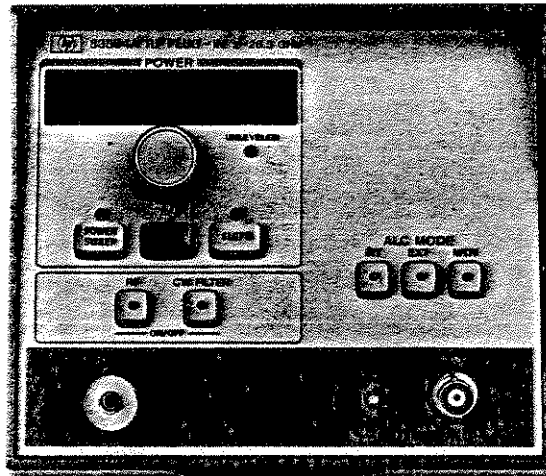

HEWLETT  
PACKARD



# **HP 83594A RF PLUG-IN (Including Options 002 and 004)**

## **SERIAL NUMBERS**

This manual applies directly to HP Model 83594A RF Plug-In having serial numbers prefixed 2144A.

With changes described in Section VII, this manual also applies to instruments with serial numbers prefixed 2143A or lower.

For additional information about serial numbers, refer to **INSTRUMENTS COVERED BY MANUAL** in Section I.

© Copyright      HEWLETT-PACKARD COMPANY      1983  
1400 FOUNTAINGROVE PARKWAY, SANTA ROSA, CA 95401 U.S.A.

MANUAL PART NO. 83594-90003  
Microfiche Part No. 83594-90004

Printed: NOVEMBER 1983



**HEWLETT  
PACKARD**

## CERTIFICATION

*Hewlett-Packard Company certifies that this product met its published specifications at the time of shipment from the factory. Hewlett-Packard further certifies that its calibration measurements are traceable to the United States National Bureau of Standards, to the extent allowed by the Bureau's calibration facility, and to the calibration facilities of other International Standards Organization members.*

## WARRANTY

This Hewlett-Packard instrument product is warranted against defects in material and workmanship for a period of one year from date of shipment. During the warranty period, Hewlett-Packard Company will, at its option, either repair or replace products which prove to be defective.

For warranty service or repair, this product must be returned to a service facility designated by HP. Buyer shall prepay shipping charges to HP and HP shall pay shipping charges to return the product to Buyer. However, Buyer shall pay all shipping charges, duties, and taxes for products returned to HP from another country.

HP warrants that its software and firmware designated by HP for use with an instrument will execute its programming instructions when properly installed on that instrument. HP does not warrant that the operation of the instrument, or software, or firmware will be uninterrupted or error free.

## LIMITATION OF WARRANTY

The foregoing warranty shall not apply to defects resulting from improper or inadequate maintenance by Buyer, Buyer-supplied software or interfacing, unauthorized modification or misuse, operation outside of the environmental specifications for the product, or improper site preparation or maintenance.

NO OTHER WARRANTY IS EXPRESSED OR IMPLIED. HP SPECIFICALLY DISCLAIMS THE IMPLIED WARRANTIES OF MERCHANTABILITY AND FITNESS FOR A PARTICULAR PURPOSE.

## EXCLUSIVE REMEDIES

THE REMEDIES PROVIDED HEREIN ARE BUYER'S SOLE AND EXCLUSIVE REMEDIES. HP SHALL NOT BE LIABLE FOR ANY DIRECT, INDIRECT, SPECIAL, INCIDENTAL, OR CONSEQUENTIAL DAMAGES, WHETHER BASED ON CONTRACT, TORT, OR ANY OTHER LEGAL THEORY.

## ASSISTANCE

*Product maintenance agreements and other customer assistance agreements are available for Hewlett-Packard products.*

*For any assistance, contact your nearest Hewlett-Packard Sales and Service Office. Addresses are provided at the back of this manual.*

## SECTION I GENERAL INFORMATION

### 1-1. INTRODUCTION

1-2. This Operating and Service Manual contains information required to install, operate, test, adjust, and service the Hewlett-Packard Model 83594A RF Plug-In. Figure 1-1 shows the Model 83594A with accessory adapter supplied.

1-3. This manual is divided into eight major sections which provide the following information:

- a. SECTION I, GENERAL INFORMATION, includes a brief description of the instrument, safety considerations, specifications, supplemental characteristics, instrument identification, options available, accessories available, and a list of recommended test equipment.
- b. SECTION II, INSTALLATION, provides information for initial inspection, preparation for use, storage, and shipment.
- c. SECTION III, OPERATION, explains the frequency resolution characteristics of the RF Plug-In in CW and swept frequency modes. Operating instructions include FM switch parameter settings, and crystal and power meter leveling instructions. A description of front and rear panel features and Plug-In error codes is also given.
- d. SECTION IV, PERFORMANCE TESTS, presents procedures required to verify that performance of the RF Plug-In is in accordance with published specifications.
- e. SECTION V, ADJUSTMENTS, presents procedures required to properly adjust and align the Model 83594A RF Plug-In after repair.
- f. SECTION VI, REPLACEABLE PARTS, provides information required to order all parts and assemblies.

g. SECTION VII, MANUAL BACKDATING CHANGES, provides backdating information required to make this manual compatible with earlier shipment configurations.

h. SECTION VIII, SERVICE, provides an overall instrument block diagram with troubleshooting and repair procedures. Each assembly within the instrument is covered on a separate Service Sheet which contains a circuit description, schematic diagram, component location diagram, and troubleshooting information to aid in the proper maintenance of the instrument.

1-4. Supplied with this manual is an Operating Information Supplement. This is simply a copy of the first three sections of the manual, which should be kept with the instrument for use by the instrument operator.

1-5. On the front cover of this manual is a Microfiche part number. This number may be used to order 10- by 15-centimeter (4- by 6-inch) microfilm transparencies of the manual. Each microfiche contains up to 60 photo duplicates of the manual pages. The microfiche package also includes the latest Manual Changes sheet as well as all pertinent Service Notes.

1-6. Refer any questions regarding this manual, the Manual Changes sheet, or the instrument to the nearest HP Sales/Service Office. Always identify the instrument by model number, complete name, and complete serial number in all correspondence. Refer to the inside rear cover of this manual for a worldwide listing of HP Sales/Service Offices.

### 1-7. SPECIFICATIONS

1-8. Listed in Table 1-1 are the specifications for the Model 83594A RF Plug-In. These specifications are the performance standards, or limits, against which the instrument may be

Table 1-1. Specifications for Model 83594A Installed in Model 8350A (1 of 3)

<b>FREQUENCY<sup>1</sup></b>					
Range: 2.0 to 26.5 GHz					
Accuracy (25°C ±5°C)	Frequency Bands (GHz)				
	2.0 to 7.0	7.0 to 13.5	13.5 to 20.0	20.0 to 26.5	2.0 to 26.5
CW Mode	±5 MHz	±10 MHz	±10 MHz	±12 MHz	---
All Sweep Modes (Sweep time ≥100 ms)	±20 MHz	±25 MHz	±30 MHz	±35 MHz	±50 MHz
Frequency Markers (Sweep time ≥100 ms)	±20 MHz ±.5% of sweep width	±25 MHz ±.5% of sweep width	±30 MHz ±.5% of sweep width	±35 MHz ±.5% of sweep width	±50 MHz ±.5% of sweep width
Stability					
With 10% Line Voltage Change	±50 kHz	±100 kHz	±150 kHz	±200 kHz	±200 kHz
With 10 dB Power Level Change	±200 kHz	±400 kHz	±600 kHz	±800 kHz	±800 kHz
With 3:1 Load SWR	±100 kHz	±200 kHz	±300 kHz	±400 kHz	±400 kHz
Residual FM, Peak (10 Hz to 10 kHz Bandwidth) (CW Mode with CW Filter)	<5 kHz	<7 kHz	<9 kHz	<12 kHz	---
<b>POWER OUTPUT<sup>1</sup></b>					
Frequency Bands (GHz)					
	2.0 to 7.0	7.0 to 13.5	13.5 to 20.0	20.0 to 26.5	2.0 to 26.5
Maximum Leveled Output Power <sup>2,3,4</sup> (25°C)	+10 dBm	+10 dBm	+10 dBm	+4 dBm	+4 dBm
With Option 002	+8.5 dBm	+8 dBm	+7 dBm	+1 dBm	+1 dBm
Power Level Accuracy <sup>5</sup> (Internally Leveled)	<±1.3 dB	<±1.3 dB	<±1.4 dB	<±1.7 dB	<±1.8 dB
With Option 002 <sup>10</sup> (at 0 dB attenuator step)	<±1.5 dB	<±1.5 dB	<±1.6 dB	<±1.9 dB	<±2.0 dB

Table 1-1. Specifications for Model 83594A Installed in Model 8350A (2 of 3)

<b>POWER OUTPUT (Cont'd)</b>													
<b>Minimum Settable Power:</b> -5 dBm With Option 002: -60 dBm													
<b>Attenuator Accuracy</b> (± dB referenced from the 0 dB setting)	<b>Frequency Range (GHz)</b>	<b>Attenuator Setting (dB)</b>											
		<b>5</b>	<b>10</b>	<b>15</b>	<b>20</b>	<b>25</b>	<b>30</b>	<b>35</b>	<b>40</b>	<b>45</b>	<b>50</b>	<b>55</b>	
		2.0 to 12.4	0.4	0.6	0.7	0.7	0.9	0.9	1.8	1.8	2.0	2.0	2.2
		12.4 to 18.0	0.5	0.7	0.9	0.9	1.2	1.2	2.0	2.0	2.3	2.3	2.5
	18.0 to 26.5	0.7	1.0	2.5	2.5	3.0	3.0	4.2	4.2	4.4	4.4	4.6	
<b>Power Variation</b> (at specified Maximum Leveled Power or below)		<b>Frequency Bands (GHz)</b>											
		<b>2.0 to 7.0</b>	<b>7.0 to 13.5</b>	<b>13.5 to 20.0</b>	<b>20.0 to 26.5</b>	<b>2.0 to 26.5</b>							
	Internally Leveled	±0.7 dB	±0.7 dB	±0.8 dB	±0.9 dB	±1.0 dB							
	Externally Leveled												
	Negative Crystal Detector <sup>7</sup> (Sweep time >100 ms)	±0.2 dB	±0.2 dB	±0.2 dB	±0.2 dB	±0.2 dB							
	Power Meter <sup>8</sup>	±0.2 dB	±0.2 dB	±0.2 dB	±0.2 dB	±0.2 dB							
	<b>Residual AM in 100 kHz Bandwidth</b> (in dB below carrier and at specified Maximum Leveled Power)	≥50 dB	≥50 dB	≥50 dB	≥50 dB	≥50 dB							
	<b>Spurious Signals (at specified Maximum Leveled Power)</b> Harmonics or Subharmonics (in dB below carrier)	>25 dB	>25dB	>25 dB	>20 dB	>20 dB							
	Non-Harmonics	>50 dB	>50 dB	>50 dB	>50 dB	>50 dB							
	<b>Output SWR (Internally Leveled)</b>	<1.9	<1.9	<1.9	<1.9	<1.9							
	With Option 002	<2.0	<2.0	<2.0	<2.2	<2.2							
	<b>Power Sweep<sup>9</sup></b> Calibrated Range <sup>10</sup> :	>15 dB	>15 dB	>15 dB	>9 dB	>9 dB							
	With Option 002:	>13.5 dB	>13 dB	>12 dB	>6 dB	>6 dB							

Table 1-1. Specifications for Model 83594A Installed in Model 8350A (3 of 3)

<b>MODULATION<sup>1</sup></b>		
<b>External AM</b> Maximum Input: 15 V		
<b>Internal AM</b> Selectable (by internal jumper in 8350A) to 1 kHz or 27.8 kHz squarewave modulation. The 27.8 kHz modulation allows operation with HP 8755 Swept Amplitude Analyzer. On/Off Ratio: $\geq 30$ dB below specified Maximum Levelled Power Symmetry: 40/60		
<b>External FM</b> Maximum Deviations for Modulation Frequencies:		
Modulation Frequency	Cross-Over Coupled	Direct Coupled
DC to 100 Hz:	$\pm 75$ MHz	$\pm 12$ MHz
100 Hz to 1 MHz:	$\pm 7$ MHz	$\pm 7$ MHz
1 MHz to 2 MHz:	$\pm 5$ MHz	$\pm 5$ MHz
2 MHz to 10 MHz:	$\pm 1$ MHz	$\pm 1$ MHz
<b>GENERAL SPECIFICATIONS<sup>1</sup></b>		
Minimum Sweep Time (over full band): 30 ms Minimum Sweep Time (over single band): 10 ms Bandswitch Points: Internal band switch points at approximately 7.0 GHz, 13.5 GHz, and 20.0 GHz. RF Output Connector: APC-3.5 Male		
<ol style="list-style-type: none"> <li>1. Unless otherwise noted, all specifications are at the RF OUTPUT connector and at 0° to 55°C.</li> <li>2. For temperatures greater than 25°C, maximum levelled output power typically degrades 0.1 dB/°C.</li> <li>3. When RF output is peaked with PEAK control.</li> <li>4. 0.5 dB lower for Option 004.</li> <li>5. Includes power level variations.</li> <li>6. Attenuator switch points are every 5 dB starting at -5 dBm indicated power.</li> <li>7. Excludes coupler and detector variation. Crystal detector output should be between -10 mV and -200 mV at specified maximum levelled power.</li> <li>8. Use HP Model 432 Power Meter. Sweep time 100 seconds; typically <math>\geq 5</math> seconds/GHz but not <math>\leq 10</math> seconds.</li> <li>9. Power Sweep and Slope Compensation total must not exceed the specified Power Sweep calibrated range.</li> <li>10. With Option 002, in Power Sweep or Slope functions, power can exceed the attenuator step by the amount that the Power Sweep calibrated range exceeds 5 dB (e.g. If the calibrated range is 7 dB, power can exceed the attenuator step by 2 dB).</li> </ol>		



Table 1-2. Supplemental Performance Characteristics for Model 83594A Installed in Model 8350A (1 of 2)

<b>NOTE</b>					
Values in this table are not specifications, but are typical characteristics included for user information.					
<b>FREQUENCY CHARACTERISTICS<sup>1</sup></b>					
<b>Accuracy (25°C ±5°C)</b>	<b>Frequency Bands (GHz)</b>				
	<b>2.0 to 7.0</b>	<b>7.0 to 13.5</b>	<b>13.5 to 20.0</b>	<b>20.0 to 26.5</b>	<b>2.0 to 26.5</b>
CW Mode Typically:	±2 MHz	±3 MHz	±4 MHz	±5 MHz	±7 MHz
Manual Sweep:	≤30 MHz	≤30 MHz	≤30 MHz	≤100 MHz	≤150 MHz
All Sweep Modes: (Sweep time 10 ms to 100 ms)	≤±6 MHz	≤±8 MHz	≤±10 MHz	≤±35 MHz	≤±50 MHz
Sweep Mode Linearity <sup>2</sup> :	≤±2 MHz	≤±4 MHz	≤±6 MHz	≤±10 MHz	≤±15 MHz
<b>Stability</b> With Temperature:	±200 kHz/°C	±400 kHz/°C	±600 kHz/°C	±800 kHz/°C	±800 kHz/°C
With Time (in a 10 minute period after one hour warmup at the same frequency setting):	<±100 kHz	<±200 kHz	<±300 kHz	<±400 kHz	<±400 kHz
<b>OUTPUT CHARACTERISTICS<sup>1</sup></b>					
<b>Power Output</b> Resolution (Displayed): 0.1 dB Resolution (Power): Typically ±0.01 dB Stability with Temperature (at specified Maximum Levelled Power): ±0.1 dB/°C					
<b>Power Variation</b> (at specified Maximum Levelled Power or below) Externally Levelled with Negative Crystal Detector <sup>3</sup> : ±0.25 dB (sweep time 10 ms to 100 ms)					
<b>Spurious Signals</b> (in dB below carrier and at specified Maximum Levelled Power)	<b>Frequency Bands (GHz)</b>				
	<b>2.0 to 7.0</b>	<b>7.0 to 13.5</b>	<b>13.5 to 20.0</b>	<b>20.0 to 26.5</b>	<b>2.0 to 26.5</b>
Harmonics and Subharmonics:	>40 dB	>35 dB	>35 dB	>35 dB	>35 dB
Non Harmonics Typically	>55 dB	>55 dB	>55 dB	>40 dB	>40 dB
<b>Impedance:</b> 50 Ohms					
<b>Power Sweep<sup>4</sup></b> Accuracy (Including Linearity): Typically ±1.5 dB Resolution (Displayed): 0.1 dB					
<b>Slope Compensation<sup>4</sup></b> Linearity: Typically <0.2 dB Calibrated Range <sup>5</sup> : Up to 5 dB/GHz; up to 10 dB for full sweep range Resolution (Displayed): 0.01 dB/GHz					

Table 1-2. Supplemental Performance Characteristics for Model 83594A Installed in Model 8350A (2 of 2)

<b>MODULATION CHARACTERISTICS<sup>1</sup></b>	
<b>External AM</b>	
Frequency Response: Typically 100 kHz	
Input Impedance: Approximately 10k Ohms	
Range of Amplitude Control: Typically 15 dB	
Sensitivity: Typically 1 dB/V	
<b>Pulse In (2.0 to 26.5 GHz)</b>	
TTL compatible: Logic high = RF on, Logic low = RF off	
Squarewave modulation up to 30 kHz (absolute error for 8755 compatibility up to 2dB, typically 1 dB)	
Rise/Fall Time:	
Unleveled:	Rise Time 5 us
	Fall Time 5 us
Leveled:	Rise Time 7 us
	Settling Time 7 us
	Fall Time 5 us
<b>External FM</b>	
Frequency Response (DC to 2 MHz): Typically $\pm 3$ dB	
Sensitivity (Switch selectable)	
Typically $-20$ MHz/V (FM Mode)	
Typically $-6$ MHz/V (Phaselock Mode)	
Input Impedance: 2000 Ohms nominal	
<b>GENERAL CHARACTERISTICS<sup>1</sup></b>	
<b>Frequency Reference Output:</b> 1 V/GHz $\pm 25$ mV (2.0 to 18 GHz) rear panel BNC output	
<b>Auxiliary Output:</b> Rear Panel 2.0 to 7.0 GHz fundamental oscillator output, nominally 0 dBm.	
<b>Weight:</b> Net 6.0 kg (13.2 lb.), Shipping 9.2 kg (20 lb.)	
<ol style="list-style-type: none"> <li>1. Unless otherwise noted, all characteristics are at the RF OUTPUT connector and at 0° to 55°C.</li> <li>2. With respect to the SWEEP OUT voltage.</li> <li>3. Excludes coupler and detector variation. Crystal detector output should be between <math>-10</math> mV and <math>-200</math> mV at specified maximum leveled power.</li> <li>4. Power Sweep and Slope Compensation must not exceed the specified Power Sweep calibrated range.</li> <li>5. With Option 002, in power sweep or slope functions, power can exceed attenuator step by the amount that the Power Sweep calibrated range exceeds 10 dB (e.g. If the calibrated range is 12 dB, power can exceed the attenuator step by 2 dB).</li> </ol>	

tested. Table 1-2 lists the RF Plug-In supplemental performance characteristics. Supplemental performance characteristics are not specifications but are typical characteristics included as additional information for the user.

### 1-9. SAFETY CONSIDERATIONS

1-10. This product has been manufactured and tested in accordance with international safety standards. Before operation, this product and related documentation must be reviewed for familiarization with safety markings and instructions. A complete listing of Safety Considerations precedes Section I of this manual.

### 1-11. INSTRUMENTS COVERED BY MANUAL

1-12. Attached to the rear panel of the instrument is a serial number plate. A typical serial number plate is shown in Figure 1-2. The serial number is in two parts. The first four digits followed by a letter comprise the serial number prefix. The last five digits form the sequential suffix that is unique to each instrument. The content of this manual applies directly to instruments having the same serial number prefix as listed on the title page of this manual under SERIAL NUMBER.

1-13. An instrument manufactured after the printing of this manual may have a serial prefix that is not listed on the title page. An unlisted serial prefix indicates that the instrument is different from those documented in this manual. The manual for the instrument is then supplied with a Manual Changes supplement that contains information which documents the differences.

1-14. In addition to change information, the Manual Changes supplement may contain information for correcting errors in the manual. To keep this manual as current as possible, Hewlett-Packard recommends that you periodically request the latest Manual Changes supplement. The supplement for this manual is keyed to the manual's print date and part number, both of which appear on the title page. Complimentary copies of the Manual Changes supplement are available on request from Hewlett-Packard.

1-15. For information concerning a serial number prefix that is not listed on the title page or in the Manual Changes Supplement, contact your nearest Hewlett-Packard Sales/Service Office.

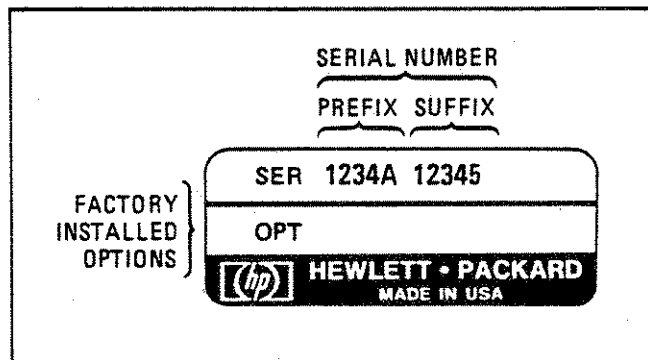

Figure 1-2. Typical Serial Number Plate

### 1-16. DESCRIPTION

1-17. The Model 83594A is an RF Plug-In which has been designed for use with the Model 8350A Sweep Oscillator. The Model 83594A covers the frequency range of 2.0 to 26.5 GHz in four bands. A YIG Oscillator is used as the tunable RF frequency source for all bands. The YIG Oscillator fundamental frequency is used for Band 1 (2.0 to 7.0 GHz). A YIG Tuned Multiplier (YTM) is used to multiply the YIG Oscillator frequency for Bands 2, 3, and 4 (6.9 to 13.5 GHz, 13.4 to 20.0 GHz, and 19.9 to 26.5 GHz).

1-18. The Model 83594A front panel functional controls, pushbuttons, and the Rotary Pulse Generator (RPG) are monitored by the Model 8350A through the RF Plug-In interface circuits. The Model 8350A generates a tuning voltage according to the mode of operation (CW, START/STOP, CFAF). This signal is scaled and offset by the Plug-In to provide a voltage ramp (in swept modes) proportional to the YIG Oscillator and YTM frequency. The Model 83594A tuning circuits accept the tuning ramp output from the Model 8350A and convert it to a current which drives the YIG Oscillator and YTM tuning coil.

1-19. The standard Model 83594A offers a maximum leveled RF output power of +10 dBm up to 20 GHz (+4 dBm above 20 GHz). Internal

(INT), External (EXT), and Power Meter (MTR) leveling are available as selected by the front panel pushbuttons. A front panel EXT/MTR ALC input connector and gain control (CAL) are provided to use with an external leveling loop. A front panel LED indicates when the RF output becomes unlevelled. The RF output level is controlled by the Model 83594A RPG, the Model 8350A data entry controls (keypad and step keys), or through HP-IB control via the Model 8350A.

1-20. A power sweep function allows the RF output power to be swept at least 5 dB during CW mode or swept frequency modes. Power sweep is selected by the front panel POWER SWEEP pushbutton. Slope compensation control is also available by selecting the SLOPE pushbutton and rotating the Model 83594A RPG or manipulating the Model 8350A data entry controls. The power sweep function and slope compensation may both be selected and modified through HP-IB (Hewlett Packard Interface Bus) control via the Model 8350A. HP-IB is Hewlett-Packard's hardware, software, documentation, and support for IEEE-488 and IEC-625, worldwide standards for interfacing instruments.

1-21. The RF output may be internally or externally amplitude modulated, or externally frequency modulated. The internal squarewave modulation frequency is selectable by the Model 8350A front panel or HP-IB. An internal 8350A jumper selects either 1 kHz or 27.8 kHz (for use with the Model 8755 Swept Amplitude Analyzer). Rear panel BNC connectors accept an external AM or FM signal. FM coupling (direct coupled or cross-over) and sensitivity are selected by an internal configuration switch in the Model 83594A. Refer to Section III, Operation, of this manual for detailed information on the configuration switch.

1-22. A rear panel 1V/GHz signal corresponds to the RF output frequency up to 18 GHz. This output voltage may be used as a reference for pretuning external equipment in phase-locking applications. (The Model 8410B/8411A Network Analyzer utilizes this output in such a configuration.)

1-23. The RF output may be turned off by the RF ON/OFF pushbutton. An internal switch is set to select whether the RF is on or off at turn

on. RF power ON is indicated by the LED in the center of the pushbutton. Additionally, in CW mode, the CW FILTER, when selected, places a capacitor across the YIG Oscillator tuning coil to filter high frequency noise which would appear at the RF output. All front panel functions, with the exception of the EXT/MTR ALC CAL adjustment, may be set or altered via the HP-IB bus connection on the Model 8350A.

## 1-24. OPTIONS

### 1-25. Option 002, 55 dB Attenuator

1-26. Option 002 instruments contain a digitally controlled attenuator just before the RF output. Up to 55 dB of attenuation in 5 dB steps is automatically selected as required to attenuate the RF output power to the indicated level. The continuously variable power level function operates as in a standard instrument with the data entry controls.

### 1-27. Option 004, Rear Panel RF Output

1-28. Option 004 instruments have the APC-3.5 RF OUTPUT connector and the BNC EXT/MTR ALC input connector on the rear panel instead of the front panel.

## 1-29. SUPPLIED ACCESSORY

1-30. Figure 1-1 shows the HP 83594A RF Plug-In and the accessory adapter supplied. The adapter type and part number are as follows:

- SMA (f) to Type N (f) HP Part No. 1250-1404.

## 1-31. EQUIPMENT REQUIRED BUT NOT SUPPLIED

1-32. To have a complete operating Sweep Oscillator unit, the Model 83594A RF Plug-In must be installed in a Model 8350A Sweep Oscillator mainframe. Refer to Section II, Installation, in this manual for a detailed description of RF Plug-In installation.

## 1-33. EQUIPMENT AVAILABLE

### 1-34. Service Accessories

1-35. A Service Accessory Kit (HP Part Number 08350-60020) is available for servicing the Model

83594A RF Plug-In and the Model 8350A Sweep Oscillator. HP Part Numbers for the individual pieces of the kit are provided in Table 1-3. The accessory kit includes:

- Two 44-pin printed circuit board extenders. These boards have keyed slots which allow them to be used in each of the keyed PC board receptacles in the Model 83594A, and in the Model 8350A as well.
- An RF Plug-In extender cable set that provides all electrical connections when the RF Plug-In is removed from the Sweep Oscillator. The RF Plug-In Interface connector (P2) and the Power Supply Interface connector (P1) are extended by separate cables.
- One Hex Balldriver for use in Model 8350A front panel repairs.
- One 16-pin and one 20-pin I.C. Test Clip for probing integrated circuits.

1-36. A listing of service accessories available including service cables, wrenches, adapters, and extender boards is given in Table 1-3.

### 1-37. Model 8410B/8411A Network Analyzer

1-38. The Model 8350A Sweep Oscillator, with the Model 83594A RF Plug-In installed, is compatible with the HP Model 8410B Network Analyzer system. The combination of the Model 8410B Network Analyzer, the Model 8411A Frequency Converter, and an appropriate display Plug-In, forms a phasemeter and a ratio-meter for direct phase and amplitude ratio measurement of RF voltages. These measurements can be made on CW frequencies and on swept frequencies from 110 MHz to 18.0 GHz. The Model 8350A/83594A combination is capable of operation from 2.0 GHz to 18 GHz within this frequency range. The Model 8410B has an Auto-Frequency range mode which gives it the capability of automatically tracking the Model 8350A Sweep Oscillator over octave and multi-octave frequency bands. Two interconnections to the Model 8350A are necessary to ensure that the Model 8410B will phase-lock properly. The Model 8410B Source Control Cable (HP 08410-60146) connects the Model 8410B rear panel SOURCE CONTROL connector to the Model 8350A rear panel

PROGRAMMING connector. Additionally, the Model 83594A RF Plug-In rear panel 1V/GHz output connects to the Model 8410B rear panel FREQ REF INPUT. The Model 8410B Source Control Cable connector pins and signals are illustrated in the Model 8350A Sweep Oscillator Operating and Service Manual.

### 1-39. Model 8755 Frequency Response Test Set

1-40. The Model 8350A Sweep Oscillator with the Model 83594A RF Plug-In installed is compatible with the Model 8755 Frequency Response Test Set for broadband swept scalar measurements. The Model 8350A provides internal 27.8 kHz squarewave amplitude modulation of the RF output, eliminating unnecessary cable connections to the Model 8755 or the use of an external modulator. The Model 8350A can also produce alternate sweeps through use of the ALT n function which works in conjunction with the channel switching circuits in the Model 8755C. This permits Channel 1 on the Model 8755C to respond only to the Model 8350A current state and Channel 2 to the alternate state. A single cable (HP Part Number 8120-3174) connects between the Model 8350A rear panel ALT SWP INTERFACE connector and the Model 8755C front panel ALT SWP INTERFACE connector.

### 1-41. Power Meters and Crystal Detectors

1-42. The RF output can be externally leveled using the HP Model 432A Power Meter or negative polarity output crystal detectors. Refer to Section III, Operation, of this manual for detailed information on leveling techniques that may be used with the Model 8350A/RF Plug-In combination.

#### NOTE

**The Model 435A and 436A Power Meters should not be used in Model 8350A/Model 83594A external leveling systems.**

### 1-43. RECOMMENDED TEST EQUIPMENT

1-44. Equipment required for testing and adjusting the instrument is listed in Table 1-4. Other equipment may be substituted if it meets or exceeds the critical specifications indicated in the table.

Table 1-3. Model 83594A Service Accessories Available

Name	HP Part Number	Description
44-pin printed circuit board extender	08350-60031*	Extends printed circuit boards
RF Plug-In Extender Cables	08350-60034*	Extends RF Plug-In Interface connector (P2)
	08350-60035*	Extends RF Plug-In Power Supply Interface connector (PI)
Adjustment Tool	8830-0024	Fits miniature adjustment slot on potentiometers
Wrenches	08555-20097	5/16" slotted box/open end
	8710-0946	15/64" open end
Service Cables	8120-1578	46 cm (18") coax with SMA (m) connector on each end
	83525-60019	25 cm (10") coax with SMB snap on (f) and SMA (m)
Adapters	1250-0777	Type N (f) to BNC (m)
	1250-0082	Type N (m) to BNC (m)
	1250-1404	Type N (f) to SMA (f)
	1250-1158	SMA (f) to SMA (f)
	1250-0674	SMA (f) to SMB (m)
	1250-0675	SMA (f) to SMC (m)
	1250-0069	SMB snap on (m) to SMB snap on (m)
	1250-1743	APC-3.5(m) to N(m)
	1250-1750	APC-3.5(m) to N(f)
	1250-1744	APC-3.5(f) to N(m)
	1250-1745	APC-3.5(f) to N(f)
	1250-1746	APC-3.5(m) to APC-7
	1250-1747	APC-3.5(f) to APC-7
	1250-1748	APC-3.5(m) to APC-3.5(m)
	1250-1749	APC-3.5(f) to APC-3.5(f)
Hex Balldriver	8710-0523*	Removes front panel hold down plate hex screws in 8350A.
IC Test Clip	1400-0734*	16-pin IC test clip
	1400-0979*	20-pin IC test clip

\* These items are included in a Service Accessories Kit HP Part No. 08350-60020 (2 board extenders are included in this kit).

Table 1-4. Recommended Test Equipment (1 of 3)

Instrument	Critical Specifications	Recommended Model	Use*
Sweep Oscillator	No substitute	HP 8350A	P,A,T
Digital Voltmeter (DVM)	Range: -50V to +50V Accuracy: $\pm 0.01\%$ Input Impedance: $\geq 10M$ Ohms	HP 3456A	A,T
Oscilloscope	Dual Channel Bandwidth: DC to 100 MHz Vertical Sensitivity: $\leq 5$ mV/DIV Horizontal Sweep Rate: $\leq 0.1$ uS/DIV External Sweep Capability	HP 1740A	P,A,T
Oscilloscope Probe	1:1 General Purpose Probe	HP 10008B	A
Frequency Counter	Frequency Range: 2.0 to 26.5 GHz Input Impedance: 50 Ohms Resolution: $\leq 1$ MHz	HP 5343A	P,A
Spectrum Analyzer	Frequency Range: 2.0 to 22.0 GHz Residual FM: <100 Hz	HP 8565A or HP 8566A	P,T

Table 1-4. Recommended Test Equipment (2 of 3)

Instrument	Critical Specifications	Recommended Model	Use*
Swept Amplitude Analyzer	Capable of Transmission Measurements. Power Resolution: $\leq 0.25$ dB	HP 8755C	A
Display Mainframe	Compatible with 8755C Swept Amplitude Analyzer	HP 180TR, 182T	A
Detector	Compatible with Swept Amplitude Analyzer Frequency Range: 2.0 to 26.5 GHz Power Range $-20$ to $+10$ dBm	HP 11664B	A
Frequency Meter	Frequency Accuracy: $\leq 0.17\%$ Calibration Increments: $\leq 2$ MHz Frequency Range: 2.0 to 4.0 GHz 4.0 to 12.4 GHz 12.4 to 18 GHz 18 to 26.5 GHz	HP 536A HP 537A HP P532A HP K532A	A A A A
Function Generator	Frequency Range: 0.1 Hz to 10 MHz Sinewave and squarewave output Output Level: 10 V <sub>p-p</sub> into 50 Ohms Output Level Flatness: $\leq \pm 3\%$ from 10 Hz to 100 kHz $\leq \pm 10\%$ from 100 kHz to 10 MHz	HP 3312A	P,A,T
Power Meter	Power Range: $-20$ to $+10$ dBm (No substitute when used for external power meter leveling).	HP 432A	P,A
Thermistor Sensor	Frequency Range: 2.0 to 18 GHz Maximum SWR: $\leq 1.75$	HP 8478B	P,A
Thermistor Sensor	Frequency Range: 18.0 to 26.5 GHz Maximum SWR: $\leq 2.0$	HP K486	P,A
Power Meter	Power Range: 1 $\mu$ W to 100 mW	HP 436A	P,A
Power Sensor	Frequency Range: 2.0 to 26.5 GHz	HP 8485A	P,A
Crystal Detector**	Frequency Response: 2.0 to 26.5 GHz Maximum Input Power: 100 mW	HP 8473C	P,A
Attenuator**	Frequency Range: 2.0 to 26.5 GHz Maximum Input Power: $+20$ dBm Attenuation: 20 dB $\pm 1.0$ dB 10 dB $\pm 0.8$ dB 6 dB $\pm 0.6$ dB 3 dB $\pm 0.5$ dB	Weinschel Model M9-20 Weinschel Model M9-10 Weinschel Model M9-6 Weinschel Model M9-3	P P,A P P

Table 1-4. Recommended Test Equipment (3 of 3)

Instrument	Critical Specifications	Recommended Model	Use*
Power Splitter**	Frequency Range: 2.0 to 26.5 GHz Maximum Input Power: $\geq +20$ dBm	Weinschel Model 1579A	P,A
Directional Coupler	Frequency Range: 2.0 to 18 GHz Nominal Coupling: $\geq 22$ dB Maximum Coupling Variation: $\pm 1$ dB Minimum Directivity: 26 dB	HP 11691D	P
Directional Coupler	Frequency Range 18 to 26.5 GHz Nominal Coupling: 10 dB Maximum Coupling Variation: $\pm 0.5$ dB Minimum Directivity: 40 dB	HP K752C	P
RMS Voltmeter	dB Range: $-20$ to $-70$ dBm (0 dBm = 1 mW into 600 Ohms) Frequency Range: 10 Hz to 10 MHz Accuracy: $\pm 5\%$ of full scale	HP 3400A	P
Air Line Extension (2 required)	Impedance: 50 Ohms Frequency Range: 2.0 to 18 GHz Reflection Coefficient: $0.018 + 0.001$ (times the frequency in GHz)	HP 11567A	P
Step Attenuator	Frequency Range: 2.0 to 26.5 GHz Incremental Attenuation 0 to 50 dB in 10 dB steps Calibration Accuracy: $\leq \pm 0.1$ dB at all steps	HP 8495D Option 890	P
Adjustable Short	Frequency Range: 2.0 to 18 GHz Impedance: $50 \pm 1.5$ Ohms	Maury Microwave 1959-2	P
Waveguide Short DC Power Supply	Frequency Range: 18.0 to 26.5 GHz DC Output: 0 to 6.5 Vdc $\pm 0.05$ Vdc	HP K920B HP 6213A	A
50 Ohm Termination	Type N, $50 \pm 0.5$ Ohms	HP 909A	P
Adapter (2 required)	APC-3.5 to Waveguide SWR $\leq 1.2$	HP K281C	P,A
Delay Line Discriminator	Refer to Figure 1-3.		P,A
PC Board Extender	44-pin, extends printed circuit boards	HP Part No. 08350-60031	A,T

\* P = Performance Test; A = Adjustments; T = Troubleshooting

\*\* For testing at frequencies of  $\leq 18$  GHz, the following equipment may be substituted:

<p>ATTENUATORS</p> <p>20 dB HP 8491B Option 020</p> <p>10 dB HP 8491B Option 010</p> <p>6 dB HP 8491B Option 006</p> <p>3 dB HP 8491B Option 003</p>	<p>POWER SPLITTER</p> <p>HP 11667A</p>	<p>CRYSTAL DETECTOR</p> <p>HP 8470B</p>
--	--	---



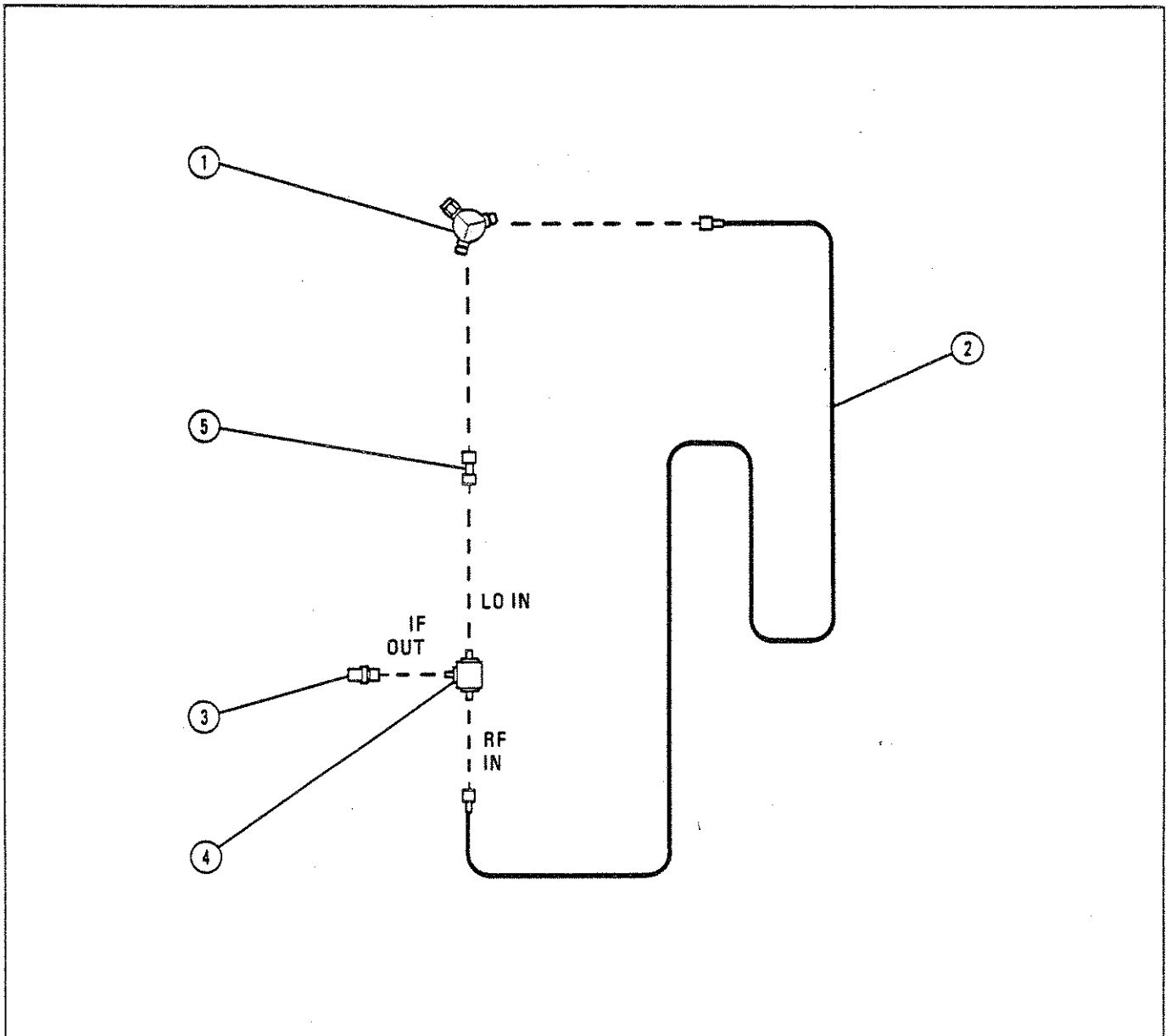

Item	Description	HP Part Number
1	Power Splitter: Weinschell Model 1579	none
2	Delay Line: > 1 meter (3 feet) in length, SMA Male connectors	08503-20038
3	Adapter: BNC Female to SMA Male	1250-1200
4	Mixer: Double Balanced  RHG Electronics Part No. DMS1-26 RHG Electronics Laboratories, Inc. Deer Park, NY 11729	none
5	Adaptor: SMA Male to SMA Male	1250-1159

Figure 1-3. Delay Line Discriminator



## SECTION II INSTALLATION

### 2-1. INTRODUCTION

2-2. This section provides installation instructions for the Model 83594A RF Plug-In. This section also includes information about initial inspection, damage claims, preparation for use, packaging, storage, and shipment.

### 2-3. INITIAL INSPECTION

2-4. Inspect the shipping container for damage. If the shipping container or cushioning material is damaged, it should be kept until the contents of the shipment have been checked for completeness and the instrument has been checked mechanically and electrically. The contents of the shipment should be as shown in Figure 1-1. Procedures for checking electrical performance are given in Section IV, Performance Tests, of this Operating and Service Manual. If the instrument combination does not pass the electrical Performance Tests, refer to Section V, Adjustments, of this manual. If, after the adjustments have been made, the instrument combination still fails to meet specifications, and a circuit malfunction is suspected, refer to troubleshooting procedures in Section VIII, Service, in this manual. If the instrument does not pass the above electrical tests, if the shipment contents are incomplete, or if there is mechanical damage or defect, notify the nearest Hewlett-Packard Office. If the shipping container is damaged, or if the cushioning material shows signs of stress, notify the carrier as well as the Hewlett-Packard Office. Keep the shipping materials for the carrier's inspection. The HP Office will arrange for repair or replacement without waiting for claim settlement.

### 2-5. PREPARATION FOR USE

### 2-6. Power Requirements

2-7. When the Model 83594A RF Plug-In is properly installed, it obtains all power through the rear panel interface connector from the Model 8350A Sweep Oscillator.

### 2-8. RF Plug-In Configuration Switch

2-9. The Model 83594A RF Plug-In has a configuration switch (A3S1) located on the A3 Digital Interface Board. This switch must be preset prior to RF Plug-In operation in the Model 8350A. The configuration switch is an 8-section multiple switch. Each separate switch section corresponds to a separate RF Plug-In function such as FM sensitivity selection, FM input coupling selection (direct coupled or cross-over), RF power level at power on (maximum or off), and Option 002 Step Attenuator operation. Refer to Section III, Operation, in this manual for a complete description of the configuration switch and instructions on how to set the switches.

### 2-10. Interconnections

2-11. There are two rear panel interconnections from the Model 83594A RF Plug-In to the Model 8350A Sweep Oscillator. These are the RF Plug-In Interface connector (P2) and the Power Supply Interface connector (P1). A complete listing of pins and associated signals for these connectors is provided in Figures 2-1 and 2-2.

### 2-12. Mating Connectors

2-13. All of the externally mounted connectors on the Model 83594A are listed in Table 2-1. Opposite each connector is an industry identification, the HP part number of a mating connector, and the part number of an alternate source for the mating connector. For HP part

numbers of the externally mounted connectors themselves, refer to Section VI, Replaceable Parts, of this manual.

**2-14. Operating Environment**

**2-15. Temperature.** The instrument may be operated in temperatures from 0°C to +55°C.

**2-16. Humidity.** The instrument may be operated in environments with humidity from 5% to 80% relative at +25°C to +40°C. However, the instrument should also be protected from temperature extremes which cause condensation within the instrument.

**2-19. Installation Instructions**

2-20. To operate as a completely functional Sweep Oscillator, the Model 83594A RF Plug-In must be installed in a Model 8350A Sweep Oscillator. To install the Model 83594A RF Plug-In in the Model 8350A Sweep Oscillator.

- a. Set the Model 8350A mainframe LINE switch to OFF.
- b. Remove all connectors and accessories from the front and rear panel connectors of the Model 83594A to prevent them from being damaged.

*Table 2-1. Mating Connectors*

83594A Connector		Mating Connector	
Connector Name	Industry Identification	HP Part No.	Alternate Source
J1 RF OUTPUT	APC-3.5 (m)	1250-1745	
J2 EXT/MTR ALC INPUT	BNC (f)	1250-0256 Straight cable	Specialty Connector 25-P118-1
J3 AUX OUTPUT	Type N (f)	1250-0882 Straight cable	Specialty Connector 25-P117-2
J4 PULSE IN	BNC (f)	1250-0256 Straight cable	Specialty Connector 25-P118-1
J5 1V/GHz	BNC (f)	1250-0256 Straight cable	Specialty Connector 25-P118-1

**2-17. Altitude.** The instrument may be operated at altitudes up to 4572 meters (15,000 feet).

**2-18. Cooling.** When the Model 83594A RF Plug-In is properly installed in the Model 8350A Sweep Oscillator, it obtains all of its cooling airflow by forced ventilation from the fan in the Model 8350A. A diagram showing the various cooling airflow paths within the Sweep Oscillator is given in Section II, Installation, of the Model 8350A Sweep Oscillator Operating and Service Manual. Ensure that all airflow passages in the Model 8350A and the Model 83594A are clear before installing the RF Plug-In in the Sweep Oscillator.

- c. Position the RF Plug-In unit latching handle in the fully raised position. The latching handle should spring easily into the raised position and be held by spring tension.
- d. Ensure that the Model 8350A RF Plug-In channel is clear. Align the RF Plug-In in the channel and slide it carefully into place toward the rear of the channel. It should slide easily without binding.
- e. The drawer latch handle slot will engage with the locking pin just before the RF Plug-In is fully seated in position.

- f Press the latch handle downward, while still pushing in on the RF Plug-In, until the drawer latch is fully closed and the front panel of the RF Plug-In is aligned with the Sweep Oscillator front panel.

## 2-21. STORAGE AND SHIPMENT

### 2-22. Environment

2-23. The instrument may be stored or shipped in environments within the following limits:

Temperature . . . . .  $-40^{\circ}\text{C}$  to  $+75^{\circ}\text{C}$   
 Humidity . . . . . 5% to 95% relative at  $0^{\circ}$  to  $+40^{\circ}\text{C}$   
 Altitude . . . . . Up to 15240 meters (50,000 feet)

2-24. The instrument should also be protected from temperature extremes which may cause condensation in the instrument.

### 2-25. Packaging

**2-26. Original Packaging.** Containers and materials identical to those used in factory packaging are available through Hewlett-Packard offices. A complete diagram and listing of packaging materials used for the Model 83594A is shown in Figure 2-3. If the instrument is being returned to Hewlett-Packard for servicing, attach a tag indicating the type of service required,

return address, model number, and full serial number (located on the rear panel serial plate). Mark the container FRAGILE to ensure careful handling. In any correspondence, refer to the instrument by model number and full serial number.

**2-27. Other Packaging.** The following general instructions should be used for repackaging with commercially available packaging materials:

- a. Wrap the instrument in heavy paper or plastic. If shipping to a Hewlett-Packard Office or Service Center, attach a tag indicating the type of service required, return address, model number, and full serial number.
- b. Use a strong shipping container.
- c. Use enough shock-absorbing material around all sides of the instrument to provide a firm cushion and to prevent movement inside the container. Protect the control panel with cardboard.
- d. Seal the shipping container securely.
- e. Mark the shipping container FRAGILE to ensure careful handling.
- f. In any correspondence, refer to the instrument by model number and full serial number.

POWER SUPPLY PLUG-IN INTERFACE CONNECTOR P1

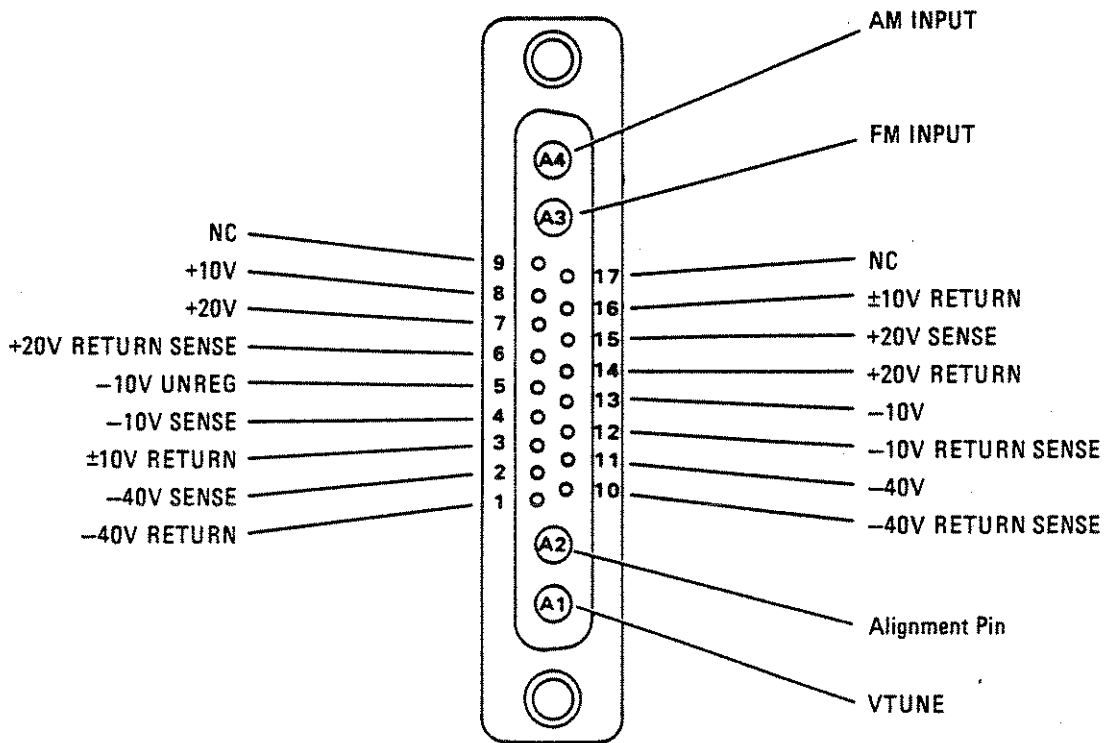

Figure 2-1. Interface Signals on Connector P1

PLUG-IN INTERFACE CONNECTOR P2

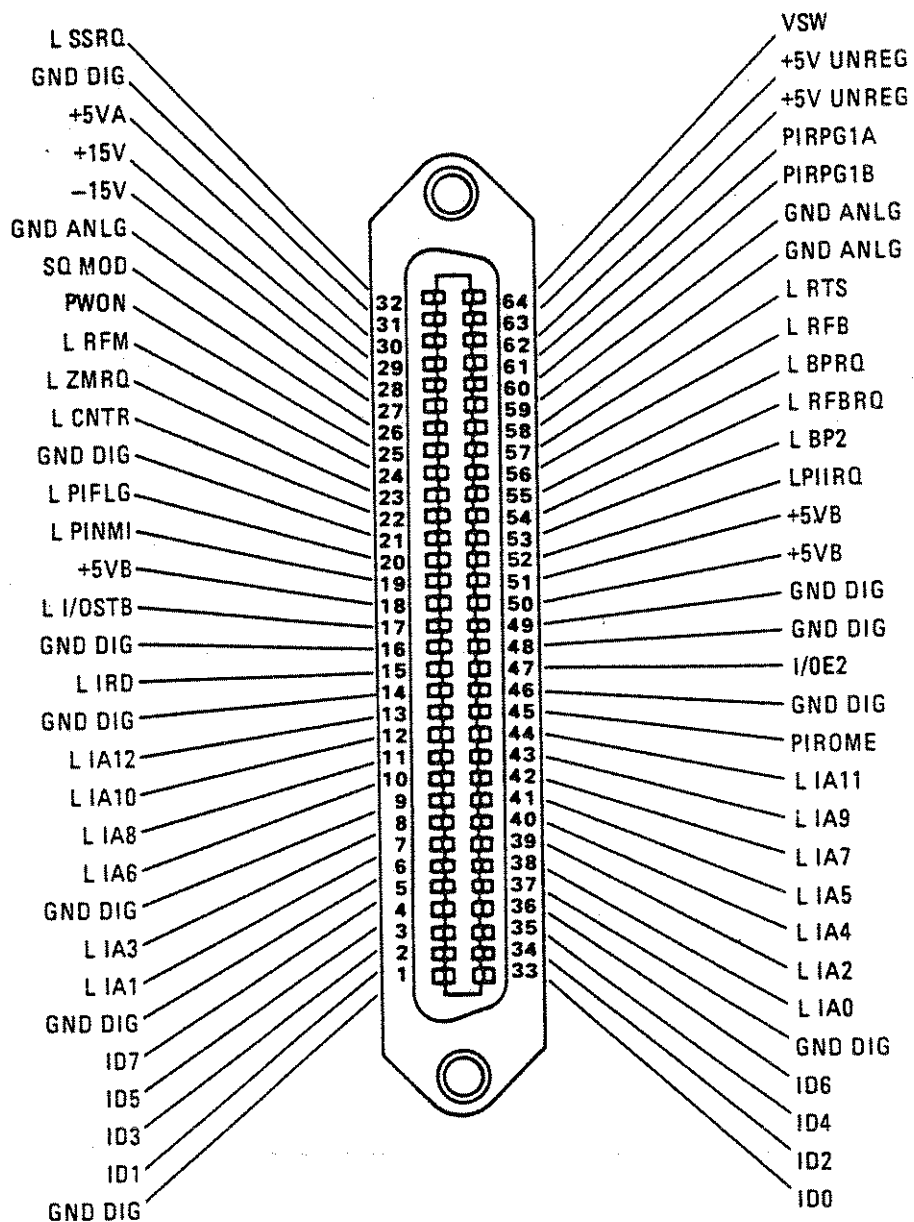
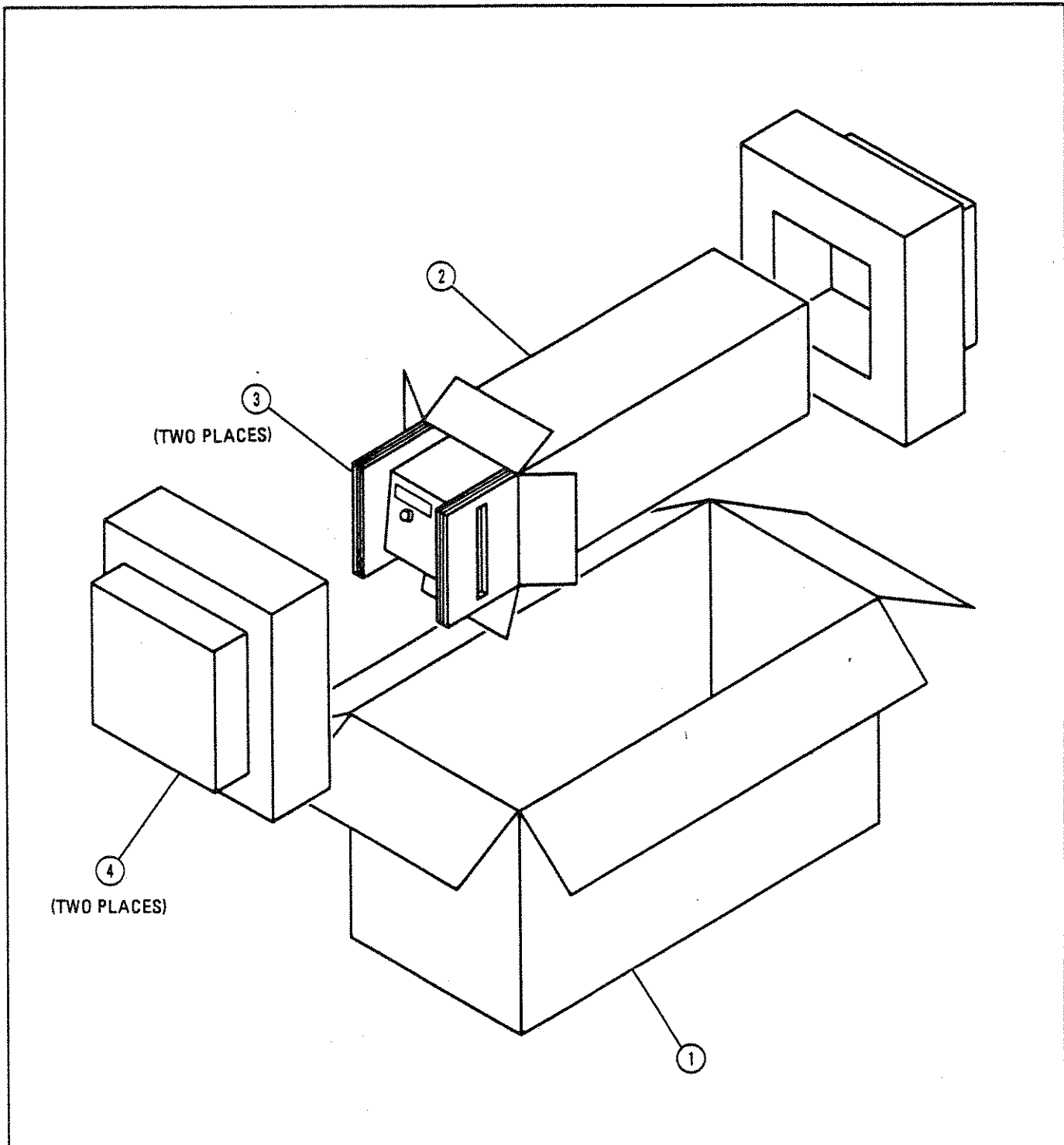

Figure 2-2. Interface Signals on Connector P2



Item	Quantity	HP Part Number	C D	Description
1	1	9211-3515	6	Outer Carton
2	1	9211-3514	5	Inner Carton
3	2	9220-3409	6	Side Pads – Corrugated Cardboard
4	2	9220-3406	3	Foam Pads
	1	9222-0352	6	Poly Bag – to cover instrument

Figure 2-3. Packaging for Shipment Using Factory Packaging Materials



## SECTION III OPERATION

### 3-1. INTRODUCTION

3-2. This section is divided into four major parts. Operating Characteristics explains the bandswitching and frequency resolution characteristics in CW and swept modes. Front and rear Panel Features are shown with illustrated descriptions. Operating Instructions provide configuration switch setting information, crystal detector and power meter leveling instructions and a phase-locking procedure. Operator's Maintenance includes information on the Plug-In error codes, fuses, and service tags.

### 3-3. OPERATING CHARACTERISTICS

#### 3-4. Bandswitching and Resolution

3-5. The following paragraphs describe the bandswitching and frequency resolution characteristics of the 83594A RF Plug-In.

3-6. The 83594A 2.0 to 26.5 GHz RF output is provided in four bands. When a range of frequencies larger than a single band is swept, the switching between bands is done automatically. Careful selection of sweep frequencies may avoid problems associated with bandswitching such as harmonics, sweep time, stability, or switching discontinuities. Figure 3-1 illustrates the bandswitching points in the sequential and single band sweep modes.

3-7. Two areas relating to frequency resolution must be considered: these are input resolution and displayed resolution. Input resolution refers to the number of bits (8 bits = 256 points) in the digital to analog converter (DAC) used to generate the tuning voltage for a particular mode of operation. Table 3-1 cross-references input resolution with each DAC used. Displayed frequency resolution refers to the number of digits shown on the 8350A FREQUENCY displays.

3-8. Figure 3-2 is a simplified block diagram of the frequency tuning circuits. The net tuning voltage results from the summation of the three

DAC outputs. With this DAC configuration the START/STOP sweep mode is computed by the microprocessor into a center frequency and a  $\Delta F$  sweep width. Therefore the operation of all sweeps is set with a center frequency and sweep width. The center frequency is specified by the Center Frequency (CF) DAC and the Vernier DAC, and the sweep width is determined by the  $\Delta F$  DAC.

3-9. The CF DAC has 12 bits, hence 4096 points across any of the Plug-In frequency bands (including overrange). The analog output ranges from zero to ten volts, which is used to coarsely specify the center frequency output of the Plug-In. These parameters give the CF DAC a resolution of 0.024% (2.5mV) over the full band (including overrange).

3-10. Resolution of Center Frequency is enhanced by a summed voltage generated by an 8-bit (256 points) Vernier DAC. Vernier range is set to  $\pm 0.05\%$  of bandwidth (including overrange). In multiband Plug-Ins, total range of the vernier will vary with each band sweep. Vernier resolution is determined by dividing  $\pm 0.05\%$  bandwidth by 256 points (128 points on either side of CF). The voltage range of the total 256 points on the Vernier DAC is equal to four points on the 12-bit CF DAC (two points on either side of CF). This increases CF resolution from 0.024% (2.5mV) to 0.00038% (.04mV), and improves the relative accuracy of the CF by a similar factor.

#### NOTE

When the vernier is adjusted through its zero-point, the CF DAC is incremented or decremented by the total value of the vernier (2 points on the CF DAC). At this time the accuracy of the Center Frequency is again entirely dependent on the CF DAC, 0.005% of bandwidth.

3-11. The  $\Delta F$  DAC has 10 bits (1024 points). The analog output from this DAC ranges from  $-5$  to  $+5$  volts to produce an even sweep on either side of the center frequency. The  $\Delta F$  resolution improves with narrower sweep widths. For broad sweeps, the resolution is 0.1% of the full band. Greater resolution is provided for sweep widths less than  $1/8$  of the full band range. At these sweep widths, the resolution is improved to 0.012% of the full band.

3-12. Center Frequency is always displayed with 1 MHz resolution. Likewise, Vernier values are always displayed at 10 kHz resolution. Display resolutions for  $\Delta F$  values vary with sweep width. Figure 3-3 illustrates the  $\Delta F$  mode displayed resolution values versus displayed  $\Delta F$  frequency sweep widths.

### 3-13. PANEL FEATURES

3-14. Front and rear panel features are described in Figures 3-4 and 3-5, respectively. Numbered callouts on the features described match numbered descriptions below each figure.

### 3-15. OPERATORS CHECKS

3-16. The Operator's Checks portion (Local and Remote) of the 8350A Sweep Oscillator manual provides a quick evaluation of both 8350A and 83594A main functions. Error codes 50 to 99, displayed on the 8350A FREQUENCY display, are reserved to indicate Plug-In related problems. The 8350A Local Check covers the Sweep Oscillator and RF Plug-In. If the correct indications are not obtained, trouble may be in either of the units. If the RF Plug-In is suspected, follow the troubleshooting information in Section VIII, Service, in this manual, to isolate the problem.

### 3-17. OPERATING INSTRUCTIONS

#### 3-18. Peaking RF Output Power

3-19. Front panel PEAK is a control used to adjust the YTM tracking of the YIG Oscillator to optimize output power by adjusting the tracking at frequencies of interest or to compensate for mistracking due to aging. The control may be used to correct small tracking offsets until adjustments are performed. The front panel PEAK function is accessed by pressing

[SHIFT] [POWER LEVEL]. In order to monitor the effect of the Peaking function on the RF output, the 83594A must be set for an unlevelled power condition. This can be accomplished by setting the ALC Mode to External (without an external detector) or increasing the Power setting until the RF output is unlevelled. With the Peak function selected and an unlevelled RF output, the POWER control should be adjusted to maximize the RF output power over the entire frequency range.

#### 3-20. Internal Leveling

3-21. The most convenient method of RF output leveling is internal leveling. A portion of the RF output is coupled out of an internal directional detector, producing a DC voltage proportional to the RF output signal. This detected DC voltage is applied to the automatic leveling control circuit (ALC).

#### 3-22. External Crystal Detector Leveling

3-23. RF output power may also be leveled externally using a power splitter (or external directional coupler) and a negative output crystal detector. This leveling system uses a power splitter to sample a portion of the RF output signal with a crystal detector to produce a DC voltage proportional to the RF output power level. The detector output voltage is compared with an internal reference voltage, and the difference voltage is applied, as modulator drive, to a PIN Modulator which changes the output power level to keep a constant RF output power level. A directional coupler may be used instead of a power splitter to sample the RF signal for the leveling loop. Directional couplers are usually narrow band devices, whereas the power splitter has a flatter frequency response over a wide frequency range. The advantage of a directional coupler is that it does not have as great a coupled loss as the 6 dB loss encountered with the power splitter, therefore a higher maximum leveled output power may be obtained. Figure 3-6 illustrates a typical crystal detector leveling setup.

#### 3-24. External Power Meter Leveling

3-25. RF output power may also be leveled with a power meter and power splitter (or directional coupler) as shown in Figure 3-7. The sweep time is limited to greater than 100 seconds

when this leveling method is used. A sample of the RF output signal is routed to a power meter which produces a DC output voltage proportional to the RF input signal level. This DC voltage is applied to the 83594A ALC circuits and compared with an internal reference voltage. A difference voltage is produced and amplified by the ALC amplifier before being applied, as modulator drive, to a PIN Modulator.

### 3-26. External FM

3-27. The 83594A RF output signal can be frequency modulated using an external modulating signal applied to the 8350A rear panel FM INPUT connector. The external FM function provides a means of obtaining an output frequency that varies under the control of an external modulating signal. A positive-going voltage at the FM INPUT causes output frequency to decrease, while a negative-going voltage causes output frequency to increase. The sensitivity and coupling of the modulating signal may be set with Configuration Switch A3S1. Figure 3-9 lists the available configuration switch settings. The configuration switch settings override 8350A Sweep Oscillator non-volatile memory settings at Instrument Preset.

### 3-28. External Amplitude Modulation

3-29. **Pulse Modulation (PULSE IN Connector on Plug-in).** The PULSE IN connector provides pulsed or squarewave modulation, where the RF output is switched on and off. This input provides an on/off power ratio of greater than 30 dB below specified maximum leveled power. The PULSE IN input is normally at a TTL HIGH (approximately +3 volts DC). When a TTL LOW signal (approximately 0 volts DC) is applied, the RF output is turned off. To get the best pulse modulation performance, the RF output power should be set at +20 dBm. With this power setting, a pulse repetition rate of up to 1 MHz is achievable in the 2.0 to 7.0 GHz frequency band (Band 1). With leveled power in this frequency range, pulse repetition rates may be up to 100 kHz. In the 7.0 to 26.5 GHz frequency bands, RF power may be squarewave modulated at repetition rates up to 30 kHz at any power output setting. The input impedance for TTL level signals is approximately 500 ohms. If the PULSE IN circuit is driven beyond TTL levels, the input impedance is reduced to approximately 200 ohms due to the diode clamping action. See the specifications and supplemental characteristics in Section I for more details on the modulation characteristics when this input is used.

Table 3-1. 83594A Input Resolution

DAC Used	Voltage Resolution	Frequency Resolution				
		Band 1 2.0 to 7.0 GHz	Band 2 7.0 to 13.5 GHz	Band 3 13.5 to 20 GHz	Band 4 20 to 26.5 GHz	Full Sweep 2.0 to 26.5 GHz
CF	2.44 mV	1.25 MHz	1.65 MHz	1.65 MHz	1.65 MHz	6.73 MHz
Vernier	38.8 $\mu$ V	19.4 kHz	26.2 kHz	26.2 kHz	26.2 kHz	106.8 kHz
$\Delta F$ 1-1/8 of band	9.78 mV	4.9 MHz	6.61 MHz	6.61 MHz	6.61 MHz	26.93 MHz
$\Delta F$ 1/8-1/64 of band	1.22 mV	612.0 kHz	826.0 kHz	826.0 kHz	826.0 kHz	3.37 MHz
$\Delta F \leq 1/64$ of band	152.7 $\mu$ V	76.6 kHz	103.2 kHz	103.2 kHz	103.2 kHz	420.8 kHz

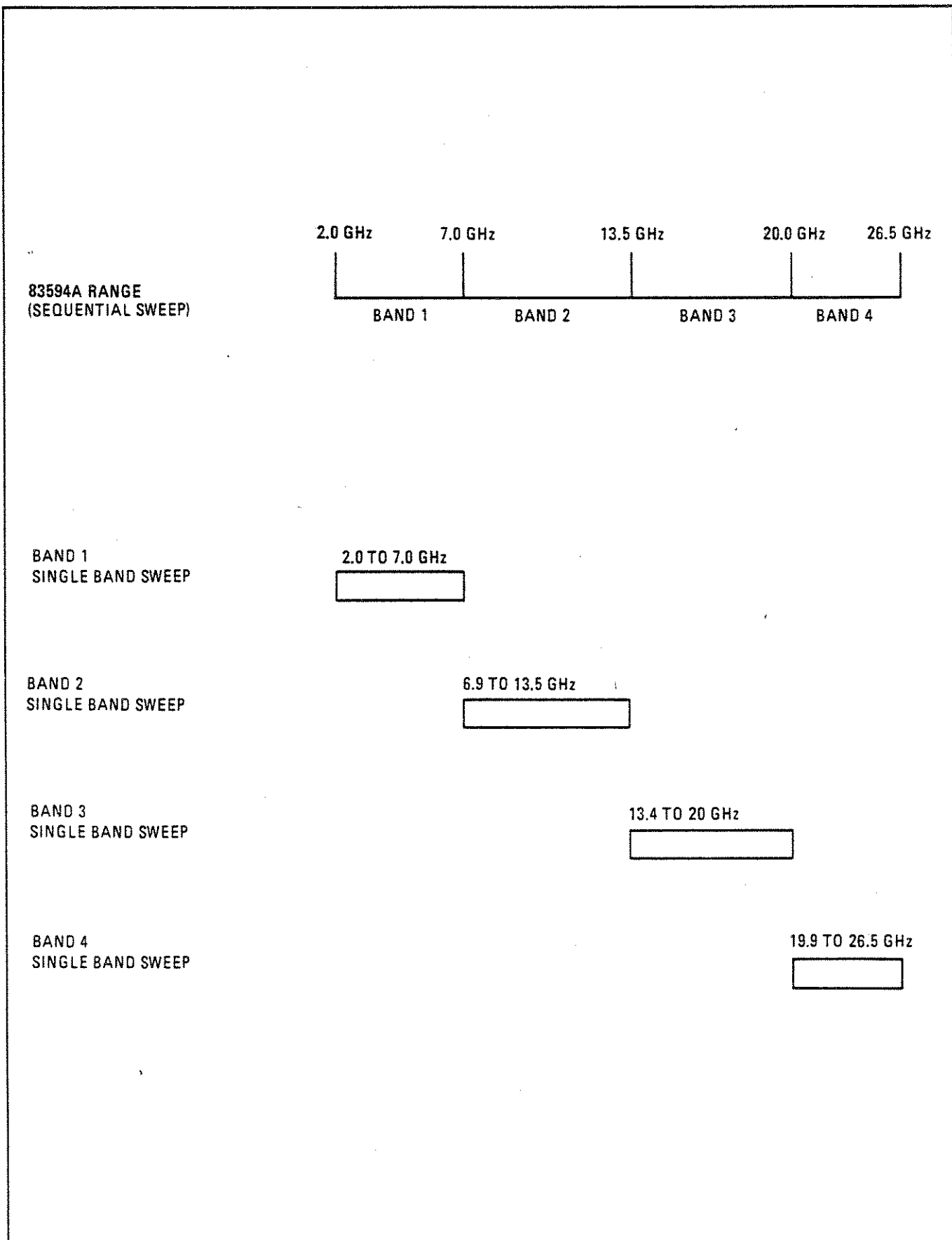

Figure 3-1. Bandswitching in Sequential and Single Band Sweep Modes

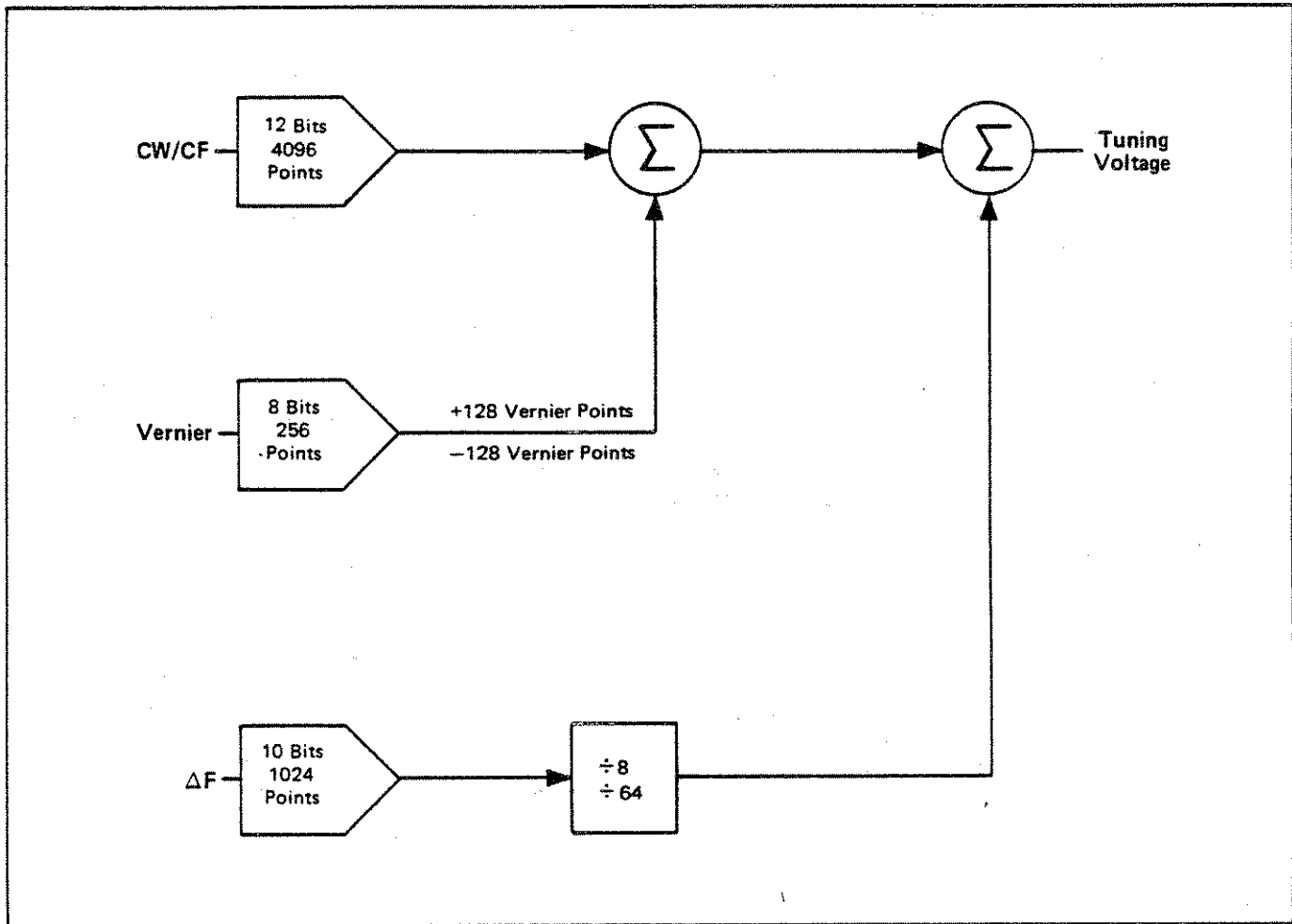

Figure 3-2. Simplified Tuning Voltage Block Diagram

**ΔF Display Frequency Width**

	0 MHz	124 MHz	1 GHz	4.2 GHz	26.5 GHz
<b>Displayed Resolution</b>	100 kHz	1 MHz	1 MHz	10 MHz	
<b>ΔF Display Indication</b>	000.0 MHz	0000. MHz	0000. MHz	00.00 GHz	

Figure 3-3. Delta F Sweep Mode Displayed Resolution

**3-30. Amplitude Modulation (AM INPUT Connector on 8350A).** The AM INPUT provides linear amplitude changes (up to approximately 15 dB) proportional to the modulating input voltage. It is limited to a frequency response of about 100 kHz. For maximum depth of modulation (i.e. maximum modulation index), the RF power level should be set to the middle of the control range (e.g. +2.5 dBm for a Plug-In with calibrated power control from -5 to +10 dBm). For Plug-Ins equipped with Option 002 (55 dB step attenuator), the middle of the attenuator range should be selected. The center of the power control range may be selected with the front panel power control or by applying a DC bias voltage on the external modulating signal. A positive (+) DC voltage into the AM INPUT causes a decrease in RF output power; a negative (-) DC voltage causes an increase in RF output power.

### 3-31. RF Power Control

3-32. The RF power set at power-up (during Instrument Preset) may be either maximum power (+10 dBm) or RF power OFF, as selected by Configuration Switch A3S1. Refer to Figure 3-9 for this setting. The configuration switch must be set prior to operation. Configuration switch section 7 is set at the factory and should not be changed.

### 3-33. Option 002 Step Attenuator

3-34. With Option 002 installed, the RF output power may be continuously controlled from maximum leveled output power down to -60 dBm. When the selected POWER setting goes below -5 dBm, the Step Attenuator increments as required in 5 dB steps to a maximum attenuation of 55 dB. Within the individual 5 dB steps of the attenuator, the ALC loop adjusts the power output to the power level programmed by the front panel POWER control. Pressing [SHIFT] [POWER SWEEP] allows control of power within the ALC range without changing attenuator settings. The display in the [SHIFT] [POWER SWEEP] mode disregards attenuator settings and only displays the ALC setting. Pressing [SHIFT] [SLOPE] allows control of attenuator steps without affecting ALC setting. In this mode the attenuator setting is displayed.

### 3-35. Alternate Sweep Mode

3-36. If the alternate sweep mode is used and the 83594A changes frequency bands (e.g. Band 1 to Band 4) between each sweep, the minimum sweep time recommended is 100 milliseconds. This allows enough time for the bandswitch operation and settling time for the fundamental oscillator for the next sweep.

3-37. If the Option 002 attenuator is installed, and alternate sweep mode is selected, a slow sweep default condition of 1 second/sweep may occur. This default condition only occurs when the POWER settings of the two alternate sweeps require the attenuator to switch after each sweep. The attenuator is prevented from switching faster than one step per second to prevent damage to the attenuator relay coils due to overheating.

### 3-38. Phase-Lock Operation

3-39. The RF output signal of the 83594A can be phase-locked to a specified CW frequency using the HP 5344S Option 043 Microwave Source Synchronizer. The 83594A signal is automatically tuned by the 5344S. Alternatively the 83594A signal can be phase-locked to an external reference oscillator. In either case, the phase-lock signal is applied to the 8350A rear panel FM INPUT connector. The phase-lock function provides a means of obtaining a very stable CW signal by transferring the frequency stability of the 5344S Source Synchronizer or the reference oscillator to the 8350A and eliminating frequency drift. The 83594A CW frequency used for phase-locking may be either the RF output or the fundamental oscillator frequency available at the rear panel AUX OUTPUT. However, use of the front panel RF output requires a broadband coupling device. Therefore it is preferable to use the rear panel AUX OUTPUT for phase-locking. Configuration Switch A3S1 switch position 8 must be set according to which 83594A output signal is used as the CW source for phase-locking (see Figure 3-9). The CW filter should be turned off in phase-lock operation. Figure 3-8 shows an example of phase-locking the 83594A front panel RF output signal using the 5344S Source Synchronizer and the 11691D 2.0 to 18.0 GHz Directional Coupler.

### 3-40. OPERATOR'S MAINTENANCE

#### 3-41. Plug-In Error Codes

3-42. The 8350A FREQUENCY window will display RF Plug-In error codes (50 to 99) or Sweep Oscillator error codes. Information necessary to interpret Plug-In error codes may be found in Section VIII, Service, in this manual.

### 3-43. Fuses

3-44. Power circuits for the Model 83594A RF Plug-In are fused in the 8350A Sweep Oscillator. See the 8350A Sweep Oscillator Operating and

Service Manual for fuse locations and replacement instructions.

### 3-45. Blue Service Tags

3-46. If the 83594A RF Plug-In requires service, the instrument may be sent to your local HP service organization as described in Section II, Installation, in this manual. Before sending the instrument back, fill out and attach one of the blue service tags. Record any error codes noted on the failure symptoms/special control settings portion of the tag.

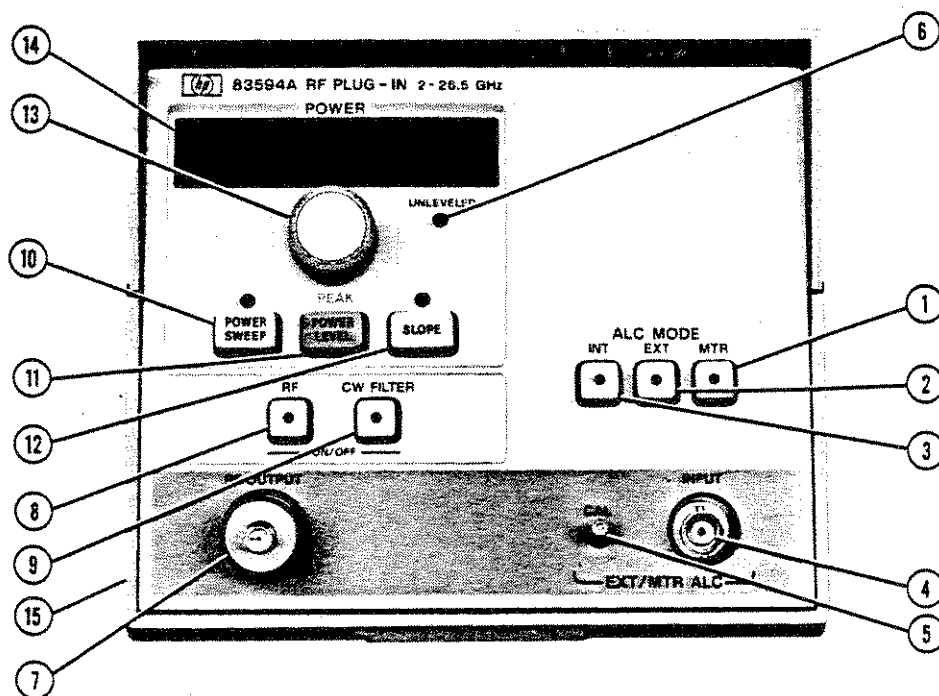

**FRONT PANEL FEATURES**

1. Power meter automatic leveling control selection (HP 432 only).
2. External (crystal detector) automatic leveling control selection (negative crystal output).
3. Internal leveling control selection.
4. Connector (BNC) for power meter or external crystal leveling inputs (rear panel on Option 004).
5. Power level CAL adjust, for setting external (MTR or EXT) ALC.
6. UNLEVELED lamp lights if output power is unlevelled.
7. APC-3.5 50-ohm RF OUTPUT connector (rear panel on Option 004).
8. RF ON-OFF key. Used for zeroing a power meter or referencing an X-Y recorder.
9. CW FILTER enables an oscillator tune voltage filter in CW mode.
10. POWER SWEEP allows setting an increase in power per sweep (dB/SWP). [SHIFT] [POWER SWEEP] (Option 002) latches the Step Attenuator at its current setting. Power level changes are controlled by the ALC loop.
11. POWER LEVEL allows setting of output power for all ALC modes (may be calibrated for external leveling). PEAK allows peaking of RF output power (selected when [SHIFT] [POWER LEVEL] is pressed).
12. SLOPE allows setting of the frequency slope compensation in dB/GHz (for lossy devices). [SHIFT] [SLOPE] (Option 002) latches the ALC loop at its current reference level. Power level changes are controlled by the Step Attenuator (in 5 dB steps).
13. Power control knob for controlling power sweep, power level, peak, or slope.
14. Plug-In display provides readout of selected power mode in dBm, dB/GHz, or dB/SWP to a tenth of a dB/dBm.
15. Plug-In latch handle is used to remove, install and latch the RF Plug-In in the Sweep Oscillator.

Figure 3-4. Front Panel Features



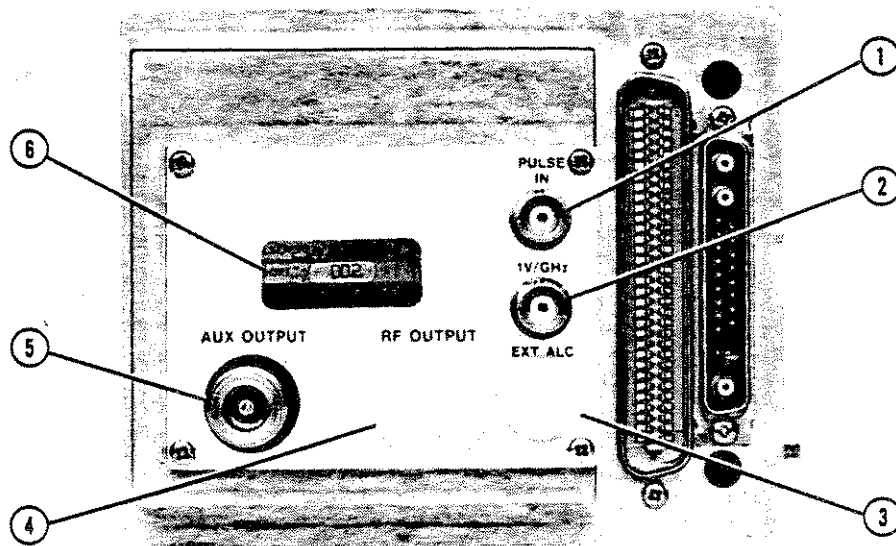

### REAR PANEL FEATURES

1. PULSE IN connector is used to input external pulse or squarewave modulation.
2. 1V/GHz connector provides a frequency reference output of approximately 1 volt DC per GHz (up to 18 GHz only).
3. EXT ALC connector replaces front panel EXT ALC connector on Option 004 Plug-Ins.
4. RF OUTPUT connector replaces front panel RF OUTPUT connector in Option 004 Plug-Ins.
5. AUX OUTPUT connector provides 2.0 to 7.0 GHz fundamental oscillator output at approximately 0 dBm.
6. Serial Number plate has a ten digit serial number (used in any correspondence concerning Plug-In) and Option number if applicable.

Figure 3-5. Rear Panel Features

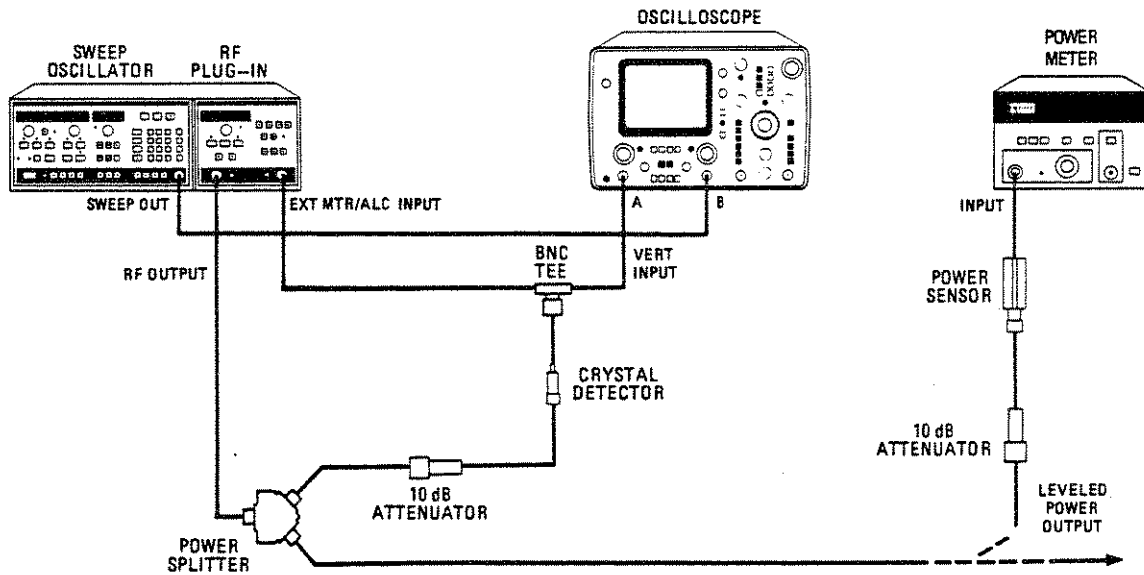

**EXTERNAL CRYSTAL DETECTOR LEVELING**

**EQUIPMENT:**

Sweep Oscillator.....	HP 8350A
RF Plug-In.....	HP 83594A
Oscilloscope.....	HP 1740A
Power Meter.....	HP 436A
Power Sensor.....	HP 8485A
Crystal Detector.....	HP 8473C
Power Splitter.....	Weinschell Model 1579
BNC Tee.....	HP 1250-0781

**PROCEDURE:**

**NOTE**

Crystal output signal must be between  $-10$  mVdc and  $-200$  mVdc.

1. Connect equipment as shown in test setup.
2. Switch on 8350A LINE switch. Press [INSTR PRESET] key. The START and STOP indicators should be on.
3. Set controls as follows:  
 83594A:  
 ALC MODE ..... EXT
4. Adjust EXT/MTR ALC CAL for a power meter reading equal to the front panel output power.
5. To use leveled RF power output for testing external equipment, make a connection at the point in the test setup marked "Leveled Power Output."

Figure 3-6. External Crystal Detector Leveling

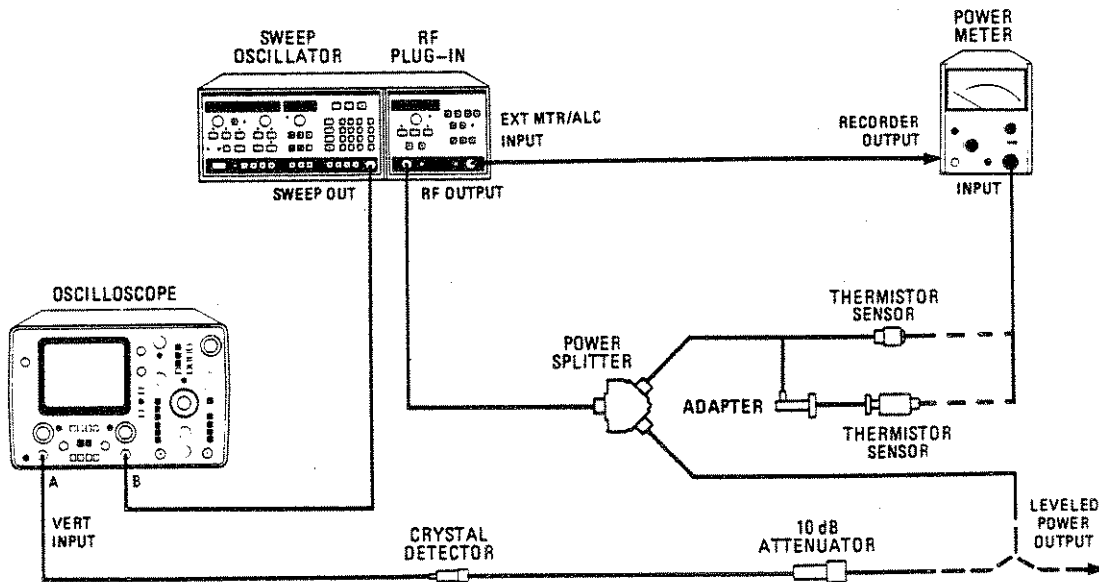

### EXTERNAL POWER METER LEVELING

#### EQUIPMENT:

Sweep Oscillator.....	HP 8350A
RF Plug-In.....	HP 83594A
Power Meter.....	HP 432A
Thermistor Sensor (2.0 to 18.0 GHz).....	HP 8478A
Thermistor Sensor (18.0 to 26.5 GHz).....	HP K486A
Oscilloscope.....	HP 1740A
Crystal Detector.....	HP 8473C
10 dB Attenuator.....	Weinschel Model 9-10
Power Splitter.....	Weinschel Model 1579
Adapter.....	HP K281C

#### NOTE

For power meter leveling, sweep rate should be 100 sec/sweep to ensure proper leveling due to the slow response of the thermistor sensor. The HP 435 and 436 power meters will not power meter level this Plug-In. Only an HP 432 may be used.

Figure 3-7. External Power Meter Leveling (1 of 2)

**PROCEDURE:**

1. Connect equipment as shown in test setup. Use the 8478A thermistor sensor for output frequencies between 2.0 and 18.0 GHz or the K486A thermistor mount and K281C adapter for frequencies between 18.0 and 26.5 GHz.
2. Set LINE switch to turn on Sweep Oscillator. The START and STOP indicators should light, indicating the START/STOP mode is selected.
3. Set controls as follows:
  - 8350A: Press [**INSTR PRESET**]
  - SWEEP TIME ..... 100 sec
  - START/STOP FREQUENCY ..... As required within thermistor  
mount limits
  - 83594A: Set power to maximum specified.
  - ALC MODE..... MTR
4. Select +5 dBm range on power meter.
5. Adjust 83594A EXT/MTR ALC CAL for a +4 dBm reading on the 432A power meter. Press 8350A [**SWEEP TRIGGER**] [**SINGLE**] key twice to set single sweep mode and start a sweep.
6. To use leveled RF output power for testing external equipment, make connection at point in test setup marked "Leveled Power Output".

*Figure 3-7. External Power Meter Leveling (2 of 2)*

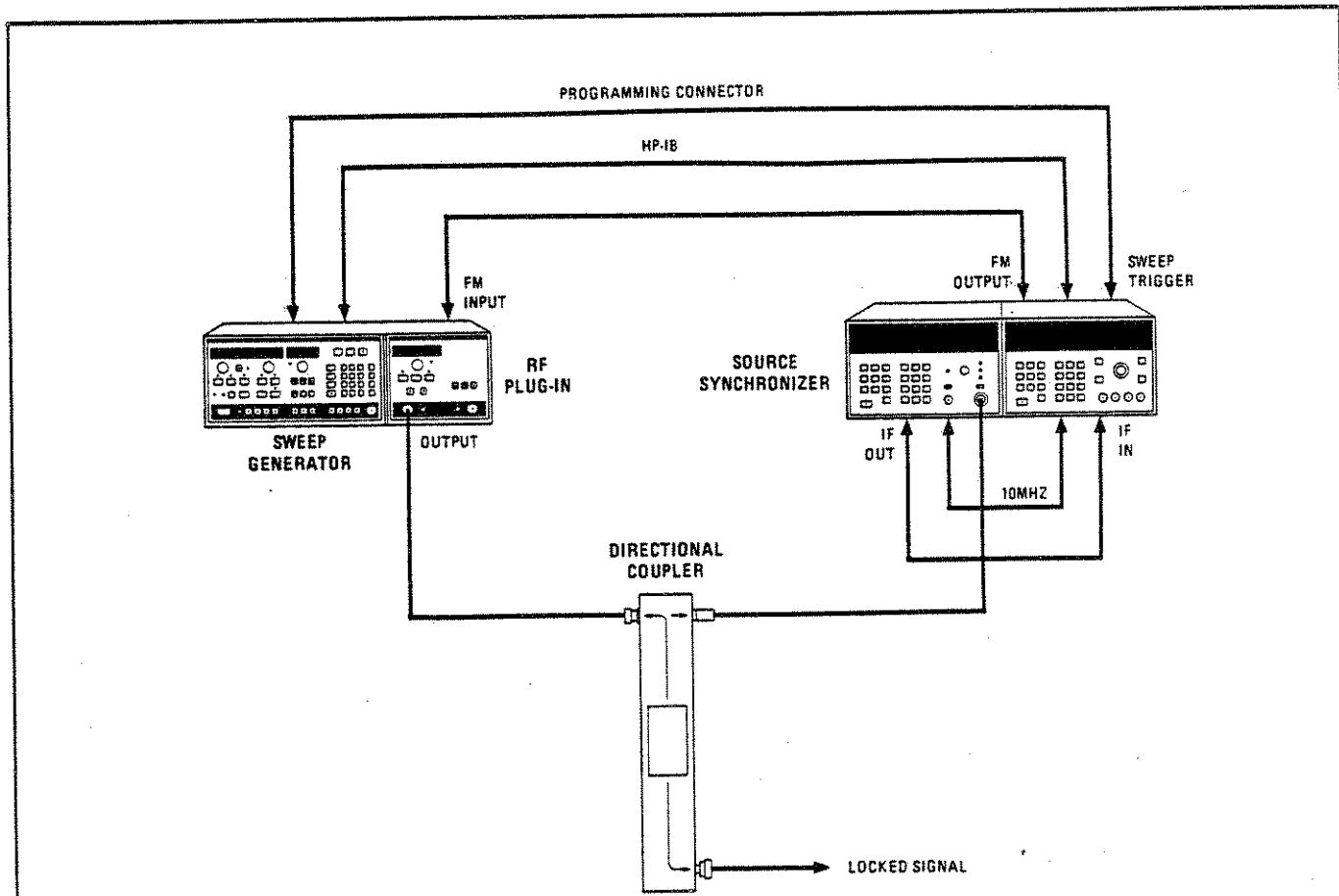

**PHASE-LOCKING USING THE 5344S SOURCE SYNCHRONIZER**

**EQUIPMENT:**

- Sweep Oscillator..... HP 8350A
- RF Plug-In..... HP 83594A
- Source Synchronizer..... HP 5344S Opt. 043
- Directional Coupler (2 to 18 GHz)..... HP 11691D

**DESCRIPTION:**

The required CW frequency for the 83594A is automatically tuned and locked by the 5344S, with the 5344S acting as an HP-IB controller. No manual tuning is required. The 8350A Sweep Oscillator and the 5344S Source Synchronizer must be set to the same HP-IB address.

**NOTE**

This setup can be used for phase-locking from 2.0 to 18.0 GHz, the range of the 11691D Directional Coupler. For phase-locking without the use of a broadband coupling device, the 83594A rear-panel AUX OUTPUT fundamental oscillator frequency signal can be used.

Figure 3-8. Phase-Locking Using the 5344S Source Synchronizer (1 of 2)

**PROCEDURE:**

1. Set the 83594A Configuration Switch (A3S1) for an FM Sensitivity of  $-6$  MHz/V, Cross-Over Coupled FM, and front panel RF OUTPUT Phase-lock (See Figure 3-9 for specific settings of A3S1).
2. Connect the equipment as shown in the test setup. Connect the HP-IB connector of the 8350A to the HP-IB connector of the 5344A section of the 5344S.
3. Set the 5344A HP-IB address to 19 (equal to the 8350A) by setting the bottom five switches to 10011.
4. Set the 5344A to the System Controller mode by setting the top HP-IB switch to the left (SYS CONT).
5. On the 8350A press [**INSTR PRESET**].
6. On the 83594A press [**CW FILTER**] to turn off the CW filter (pushbutton LED turned off). Set the 83594A Power Level between 0 and +5 dBm.
7. Set the 8350A HP-IB address to 19 if it is not already. Press [**SHIFT**] [**LCL**] [**0**] [**GHz s**]. The HP-IB address will be shown on the 8350A FREQUENCY/TIME display.
8. On the 5344A, make sure that MANUAL LOCK and AUTO LOCK are both set to off (pushbutton LEDs off). Verify that the front panel CONT lamp is on.
9. Press the 5344A [**MODE**] key until the CW annunciator lights. The MODE key will scroll through the four modes of operation. If you pass CW, continue pressing MODE until you return to CW.
10. On the 5344A, enter the frequency required for the 83594A RF output signal.
11. Press the 5344A [**AUTO LOCK**] key. The 83594A RF output signal will now be programmed and locked to the specified CW frequency.

*Figure 3-8. Phase-Locking Using the 5344S Source Synchronizer (2 of 2)*

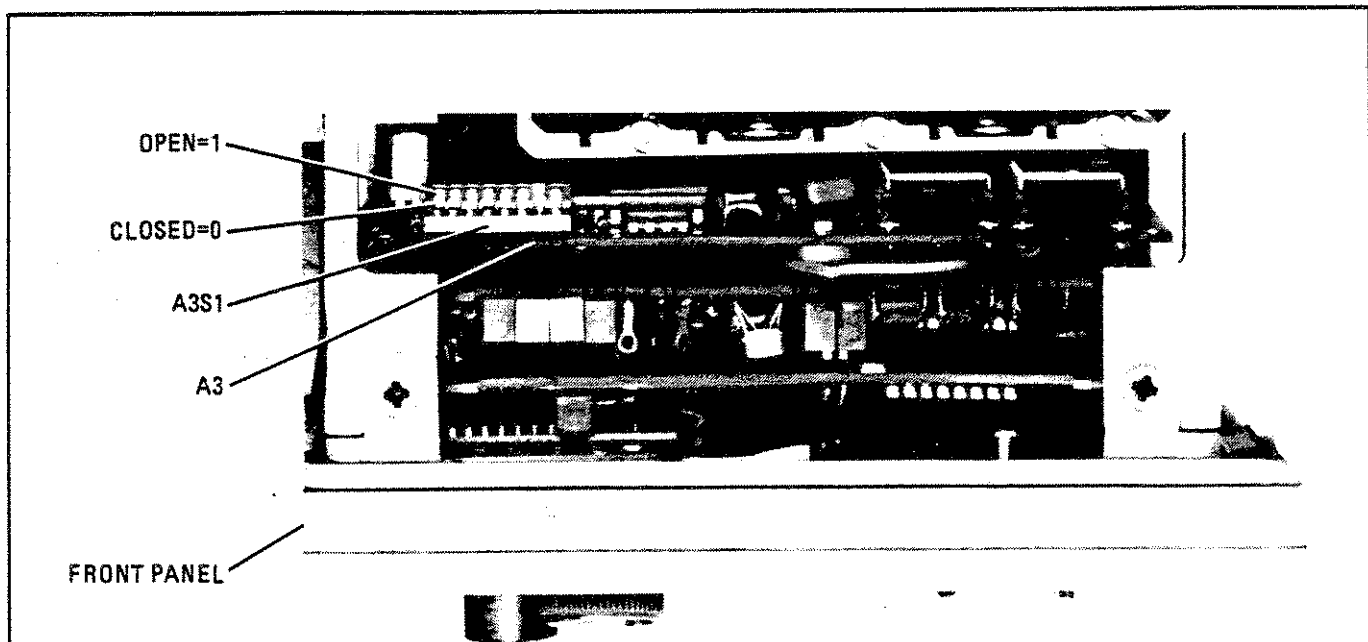

Description	Switch Number							
	1	2	3	4	5	6	7	8
Normal Sweep	0	X	X	X	X	X	X	X
Sequential Sweep Only	1	X	X	X	X	X	X	X
No RF Power at Instrument Preset	X	X	X	1	X	X	X	X
Maximum RF Power at Instrument Preset	X	X	X	0	X	X	X	X
-6 MHz/V FM Sensitivity	X	X	X	X	1	X	X	X
-20 MHz/V FM Sensitivity	X	X	X	X	0	X	X	X
Direct-Coupled FM (-20 MHz/V)	X	X	X	X	X	1	X	X
Cross-Over Coupled FM	X	X	X	X	X	0	X	X
Step Attenuator	X	X	X	X	X	X	1	X
Option 002 Installed	X	X	X	X	X	X	0	X
No Step Attenuator	X	X	X	X	X	X	0	X
AUX OUT Phase Lock	X	X	X	X	X	X	X	1
RF OUTPUT Phase Lock	X	X	X	X	X	X	X	0

**NOTES**

1. Switch Positions:

- 1 = Switch Open = High
- 0 = Switch Closed = Low (Ground)
- X = Don't Care
- \* = Varies, 1 if Opt. 002, 0 if no Opt. 002.

2. Switch is set at the factory as follows:

Switch No.	1	2	3	4	5	6	7	8
Position	0	X	X	0	0	0	*	0

Figure 3-9. Configuration Switch

