

83592A
RF PLUG-IN
.01-20.0 GHz

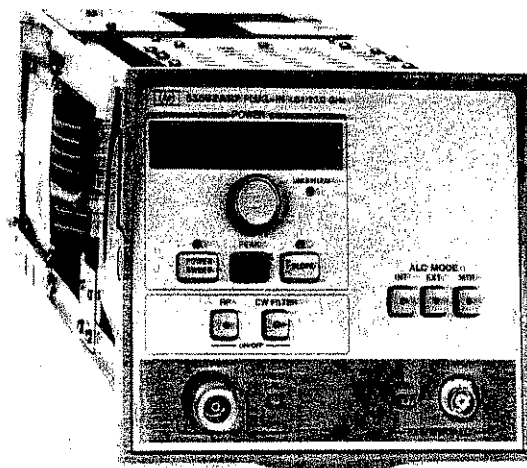

Preliminary Manual



1
2
3
4
5
6
7
8
9
10
11
12
13
14
15
16
17
18
19
20
21
22
23
24
25
26
27
28
29
30
31
32
33
34
35
36
37
38
39
40
41
42
43
44
45
46
47
48
49
50
51
52
53
54
55
56
57
58
59
60
61
62
63
64
65
66
67
68
69
70
71
72
73
74
75
76
77
78
79
80
81
82
83
84
85
86
87
88
89
90
91
92
93
94
95
96
97
98
99
100

83592A
RF PLUG-IN
(Including Options 002, 004, and 005)

SERIAL NUMBERS

This manual applies directly to HP Model 83592A
RF Plug-in having serial number prefix 2101A.

For additional information about serial numbers,
refer to **INSTRUMENTS COVERED BY
MANUAL** in Section I.

© Copyright 1981 HEWLETT-PACKARD COMPANY
1400 FOUNTAIN GROVE PARKWAY, SANTA ROSA, CALIF. 95404 U.S.A.

MANUAL PART NO. 83592-90001

Printed: MARCH 1981



**HEWLETT
PACKARD**

CERTIFICATION

Hewlett-Packard Company certifies that this product met its published specifications at the time of shipment from the factory. Hewlett-Packard further certifies that its calibration measurements are traceable to the United States National Bureau of Standards, to the extent allowed by the Bureau's calibration facility, and to the calibration facilities of other International Standards Organization members.

WARRANTY

This Hewlett-Packard instrument product is warranted against defects in material and workmanship for a period of one year from date of shipment. During the warranty period, Hewlett-Packard Company will, at its option, either repair or replace products which prove to be defective.

For warranty service or repair, this product must be returned to a service facility designated by HP. Buyer shall prepay shipping charges to HP and HP shall pay shipping charges to return the product to Buyer. However, Buyer shall pay all shipping charges, duties, and taxes for products returned to HP from another country.

HP warrants that its software and firmware designated by HP for use with an instrument will execute its programming instructions when properly installed on that instrument. HP does not warrant that the operation of the instrument, or software, or firmware will be uninterrupted or error free.

LIMITATION OF WARRANTY

The foregoing warranty shall not apply to defects resulting from improper or inadequate maintenance by Buyer, Buyer-supplied software or interfacing, unauthorized modification or misuse, operation outside of the environmental specifications for the product, or improper site preparation or maintenance.

NO OTHER WARRANTY IS EXPRESSED OR IMPLIED. HP SPECIFICALLY DISCLAIMS THE IMPLIED WARRANTIES OF MERCHANTABILITY AND FITNESS FOR A PARTICULAR PURPOSE.

EXCLUSIVE REMEDIES

THE REMEDIES PROVIDED HEREIN ARE BUYER'S SOLE AND EXCLUSIVE REMEDIES. HP SHALL NOT BE LIABLE FOR ANY DIRECT, INDIRECT, SPECIAL, INCIDENTAL, OR CONSEQUENTIAL DAMAGES, WHETHER BASED ON CONTRACT, TORT, OR ANY OTHER LEGAL THEORY.

ASSISTANCE

Product maintenance agreements and other customer assistance agreements are available for Hewlett-Packard products.

For any assistance, contact your nearest Hewlett-Packard Sales and Service Office. Addresses are provided at the back of this manual.

SAFETY CONSIDERATIONS

GENERAL

This product and related documentation must be reviewed for familiarization with safety markings and instructions before operation. This product has been designed and tested in accordance with international standards.

SAFETY SYMBOLS



Instruction manual symbol: the product will be marked with this symbol when it is necessary for the user to refer to the instruction manual (refer to Table of Contents).



Indicates hazardous voltages.



Indicates earth (ground) terminal.

WARNING

The WARNING sign denotes a hazard. It calls attention to a procedure, practice, or the like, which, if not correctly performed or adhered to, could result in personal injury. Do not proceed beyond a WARNING sign until the indicated conditions are fully understood and met.

CAUTION

The CAUTION sign denotes a hazard. It calls attention to an operating procedure, practice, or the like, which, if not correctly performed or adhered to, could result in damage to or destruction of part or all of the product. Do not proceed beyond a CAUTION sign until the indicated conditions are fully understood and met.

SAFETY EARTH GROUND

This is a Safety Class I product (provided with a protective earthing terminal). An uninterrupted safety earth ground must be provided from the main power source to the product input wiring terminals, power cord, or supplied power cord set. Whenever it is likely that the protection has been impaired, the product must be made inoperative and be secured against any unintended operation.

BEFORE APPLYING POWER

Verify that the product is configured to match the available main power source per the input power configuration instructions provided in this manual.

If this product is to be energized via an autotransformer make sure the common terminal is connected to the neutral (grounded) side of mains supply).

SERVICING

WARNING

Any servicing, adjustment, maintenance, or repair of this product must be performed only by qualified personnel.

Adjustments described in this manual may be performed with power supplied to the product while protective covers are removed. Energy available at many points may, if contacted, result in personal injury.

Capacitors inside this product may still be charged even when disconnected from its power source.

To avoid a fire hazard, only fuses with the required current rating and of the specified type (normal blow, time delay, etc.) are to be used for replacement.

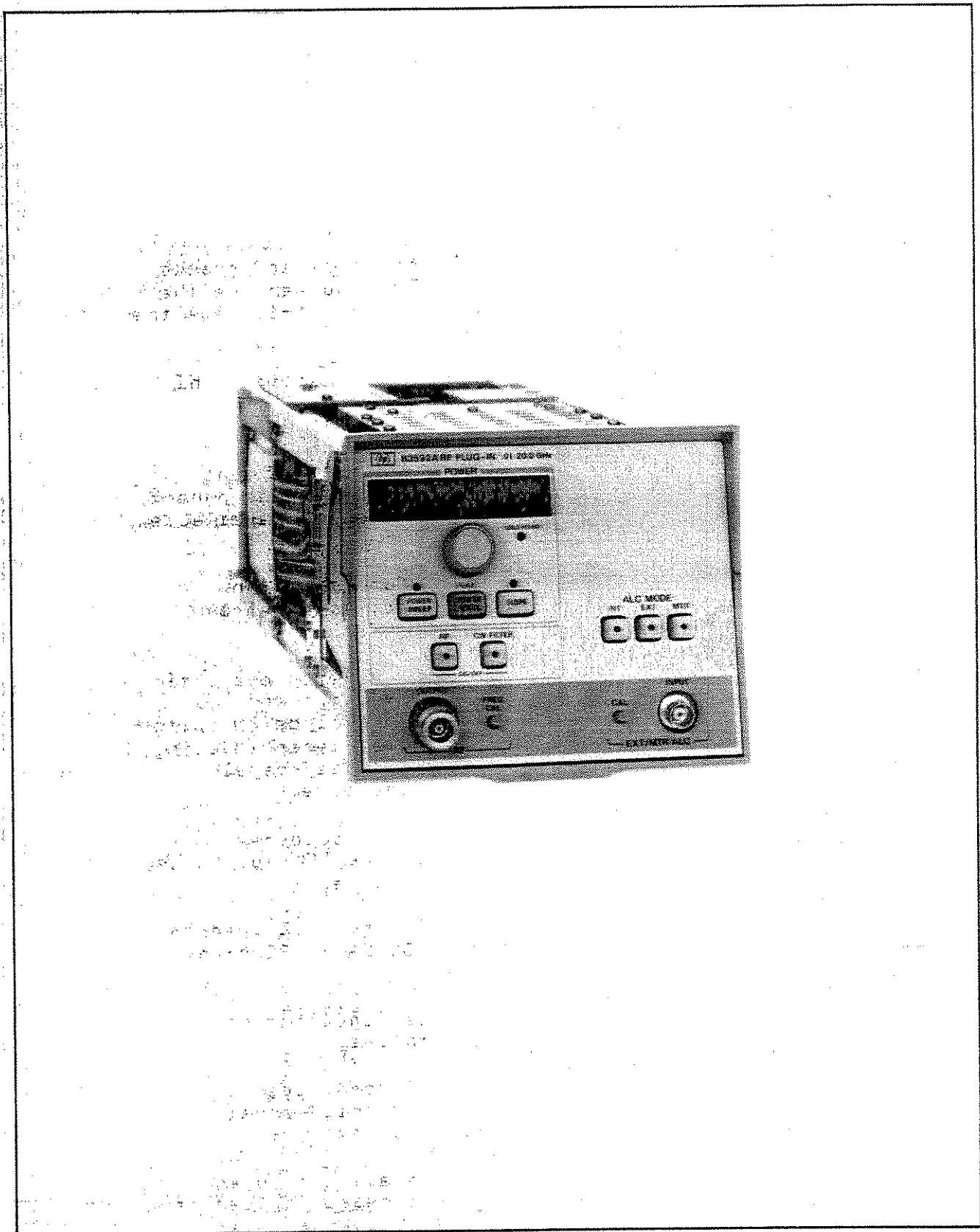

Figure 1-1. Model 83592A RF Plug-In

SECTION I

GENERAL INFORMATION

1-1. INTRODUCTION

1-2. This Operating and Service Manual contains information required to install, operate, test, adjust, and service the Hewlett-Packard Model 83592A RF Plug-in. Figure 1-1 shows the Model 83592A.

1-3. This manual is divided into eight major sections which provide the following information:

- a. SECTION I, GENERAL INFORMATION, includes a brief description of the instrument, safety considerations, specifications, supplemental characteristics, instrument identification, options available, accessories available, and a list of recommended test equipment.
- b. SECTION II, INSTALLATION, provides information for initial inspection, preparation for use, storage, and shipment.
- c. SECTION III, OPERATION, explains the frequency resolution characteristics of the RF plug-in in CW and swept frequency modes. Operating instructions include FM switch parameter settings, and crystal and power meter leveling instructions. A description of front and rear panel features and plug-in error codes is also given.
- d. SECTION IV, PERFORMANCE TESTS, presents procedures required to verify that performance of the RF Plug-in is in accordance with published specifications.
- e. SECTION V, ADJUSTMENTS, presents procedures required to properly adjust and align the Model 83592A RF Plug-in after repair.
- f. SECTION VI, REPLACEABLE PARTS, provides information required to order all parts and assemblies.
- g. SECTION VII, MANUAL BACKDATING CHANGES, provides backdating information required to make this manual compatible with earlier shipment configurations.
- h. SECTION VIII, SERVICE, provides an overall instrument block diagram with troubleshooting and repair procedures. Each assembly within the instrument is covered on a separate Service Sheet which contains a circuit

description, schematic diagram, component location diagram and troubleshooting information to aid in the proper maintenance of the instrument.

1-4. Supplied with this manual is an Operating Information Supplement. This is simply a copy of the first three sections of the manual which should be kept with the instrument for use by the instrument operator.

1-5. On the front cover of this manual is a "Microfiche" part number. This number may be used to order 10- by 15-centimeter (4- by 6-inch) microfilm transparencies of the manual. Each microfiche contains up to 60 photo duplicates of the manual pages. The microfiche package also includes the latest Manual Changes sheet as well as all pertinent Service Notes.

1-6. Refer any questions regarding this manual, the Manual Changes sheet, or the instrument to the nearest HP Sales/Service Office. Always identify the instrument by model number, complete name, and complete serial number in all correspondence. Refer to the inside rear cover of this manual for a worldwide listing of HP Sales/Service Offices.

1-7. SPECIFICATIONS

1-8. Listed in Table 1-1 are the specifications for the Model 83592A RF Plug-in. These specifications are the performance standards, or limits, against which the instrument may be tested. Table 1-2 lists the RF Plug-in supplemental performance characteristics. Supplemental performance characteristics are not specifications but are typical characteristics included as additional information for the user.

1-9. SAFETY CONSIDERATIONS

1-10. This product has been manufactured and tested in accordance with international safety standards. Before operation, this product and related documentation must be reviewed for familiarization with safety markings and instructions. A complete listing of Safety Considerations precedes Section I of this manual.

1-11. INSTRUMENTS COVERED BY MANUAL

1-12. Attached to the rear panel of the instrument is a serial number plate. A typical serial number plate is shown in Figure 1-2. The serial number is in two parts. The first four digits followed by a letter comprise the serial number

prefix. The last five digits form the sequential suffix that is unique to each instrument. The content of this manual applies directly to instruments having the same serial number prefix as those listed on the title page of this manual under SERIAL NUMBER.

1-13. An instrument manufactured after the printing of this manual may have a serial prefix that is not listed on the title page. An unlisted serial prefix indicates that the instrument is different from those documented in this manual. The manual for the instrument is then supplied with a Manual Changes supplement that contains information which documents the differences.

1-14. In addition to change information, the Manual Changes supplement contains information for correcting errors in the manual. To keep this manual as current as possible, Hewlett-Packard recommends that you periodically request the latest Manual Changes supplement. The supplement for this manual is keyed to the manual's print date and part number, both of which appear on the title page. Complimentary copies of the Manual Changes supplement are available on request from Hewlett-Packard.

1-15. For information concerning a serial number prefix that is not listed on the title page or in the Manual Changes Supplement, contact your nearest Hewlett-Packard Sales/Service Office.

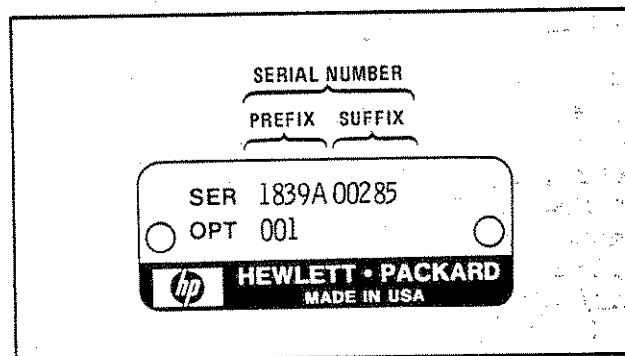

Figure 1-2. Typical Serial Number Plate

Table 1-1. Specifications for Model 83592A
Installed in Model 8350A (page 1 of 5)

FREQUENCY

Range: 0.01 to 20.0 GHz

Frequency Bands (GHz)	.01 to 2.4	2.4 to 7.0	7.0 to 13.5	13.5 to 20.0	.01 to 20.0
-----------------------	------------	------------	-------------	--------------	-------------

Accuracy
(25°C ±5°C)

CW Mode	±5 MHz ²	±5 MHz	±10 MHz	±15 MHz	-----
All Sweep Modes (Sweep time >100 ns)	±15 MHz ²	±20 MHz	±25 MHz	±30 MHz	±50 MHz ²
Frequency Markers (Sweep time >100 ns)	±15 MHz ±.5% ² of sweep width	±20 MHz ±.5% of sweep width	±25 MHz ±.5% of sweep width	±30 MHz ±.5% of sweep width	±50 MHz ±.5% ² of sweep width

Stability

With 10% Line Voltage Change	±50 kHz	±50 kHz	±100 kHz	±150 kHz	±150 kHz
With 10 dB Power Level Change	±200 kHz	±200 kHz	±400 kHz	±600 kHz	±600 kHz
With 3:1 Load SWR	±100 kHz	±100 kHz	±200 kHz	±300 kHz	±300 kHz
With Time (In a 10 minute period after one hour warmup)	<±100 kHz	<±100 kHz	<±200 kHz	<±300 kHz	<±300 kHz
Residual FM, Peak (10 kHz Bandwidth) (CW Mode with CW Filter)	<8 kHz	<8 kHz	<15 kHz	<15 kHz	-----

Table 1-1. Specifications for Model 83592A
Installed in 8350A (page 2 of 5)

POWER OUTPUT

Frequency Bands (GHz)	0.01 to 2.4	2.4 to 7.0	7.0 to 13.5	13.5 to 18.6	13.5 to 20.0	.01 to 18.6	.01 to 20.0
Maximum Levelled ^{3,4,5} Output Power (25°C)	+10 dBm	+10 dBm	+10 dBm	+10 dBm	+8 dBm	+10 dBm	+8 dBm
With Option 002	+10 dBm	+8.5 dBm	+8 dBm	+7 dBm	+5 dBm	+7 dBm	+5 dBm
Power Level Accuracy ^{1,2} (Internally Levelled)	<±1.5 dB	<±1.3 dB	<±1.3 dB	<±1.4 dB	<±1.4 dB	<±1.5 dB	<±1.5 dB
With Option 002 ⁶ (at 0 dB attenuator step)	<±1.7 dB	<±1.5 dB	<±1.5 dB	<±1.6 dB	<±1.6 dB	<±1.7 dB	<±1.7 dB
Calibrated Range	15 dB	15 dB	15 dB	15 dB	13 dB	15 dB	13 dB
With Option 002	82 dB	82 dB	82 dB	82 dB	80 dB	82 dB	80 dB

Attenuator Accuracy (± dB referenced from the 0 dB setting)

Frequency Range (GHz)	Attenuator setting (dB)						
	10	20	30	40	50	60	70
.01 - 12.4	0.6	0.7	0.9	1.0	2.0	2.2	2.3
12.4 - 18.0	0.7	0.9	1.2	2.0	2.3	2.5	2.8
18.0 - 20.0	0.9	1.5	2.5	3.0	3.2	3.3	3.5

Power Variation

(at specified Maximum Levelled Power or below)

Frequency Bands (GHz)	.01 to 2.4	2.4 to 7.0	7.0 to 13.5	13.5 to 20	.01 to 20
Internally Levelled	±0.9 dB	±0.7 dB	±0.7 dB	±0.8 dB	±0.9 dB
Externally Levelled ⁷					
Negative Crystal Detector ⁸ (Sweep time >100 ns)	±0.2 dB	±0.2 dB	±0.2 dB	±0.2 dB	±0.2 dB
Power Meter ⁹	±0.2 dB	±0.2 dB	±0.2 dB	±0.2 dB	±0.2 dB

Table 1-1. Specifications for Model 83592A
 Installed in Model 8358A (Page 3 of 5)

POWER OUTPUT (CONT'D)

<u>Frequency Bands (GHz)</u>	.01 to 2.4	2.4 to 7.0	7.0 to 13.5	13.5 to 20.0	0.01 to 20.0
<u>Residual AM in 100 kHz Bandwidth</u> (in dB below carrier and at specified maximum leveled power)	>50 dB	>50 dB	>50 dB	>50 dB	>50 dB
<u>Spurious Signals at specified maximum leveled power</u>					
Harmonics (in dB below carrier)	>25 dB	>25 dB	>25dB	>25 dB	>25 dB
Non-Harmonics	>25 dB	>50 dB	>50 dB	>50 dB	>25 dB
<u>Output VSWR (internally leveled)</u>	<1.9	<1.9	<1.9	<1.9	<1.9
With Option 002	<2.1	<2.1	<2.1	<2.1	<2.1

Power Sweep¹⁰

Calibrated Range: > 15dB (13 dB above 18.6 GHz)

Table 1-1. Specifications for Model 83592A
 Installed in Model 8350A (Page 4 of 5)

MODULATION

External AM

Maximum Input: 15 V

Internal AM

Selectable (by internal jumper in 8350A) to 1 kHz or 27.8 kHz square wave modulation. The 27.8 kHz modulation rate allows operation with HP 8755A/B/C Swept Amplitude Analyzer.

On/Off Ratio: 20 dB below specified maximum leveled power

Symmetry: 40/60

External FM

Maximum Deviations for Modulation Frequencies:

	Cross Over Coupled	Direct Coupled
DC to 100 Hz:	±75 MHz	±12 MHz
100 Hz to 1 MHz:	± 7 MHz	±7 MHz
1 MHz to 2 MHz:	± 5 MHz	±5 MHz
2 MHz to 10 MHz:	±1 MHz	±1 MHz

Table 1-1. Specifications for Model 83572A
Installed in Model 8350A (Page 5 of 5)

GENERAL SPECIFICATIONS

Minimum Sweep Time (over full band): 25 ms

Minimum Sweep Time (Over single band): 10 ms

Band Switch Points: Internal band switch points at approximately 2.4 GHz, 7.0 GHz, and 13.5 GHz

RF Output Connector: Type N Female

- 1 Unless otherwise noted, all specifications are at the RF OUTPUT connector and at 0° to 55°C.
- 2 Accuracy when calibrated with the FREQ CAL adjustment.
- 3 For temperatures greater than 25°C, maximum leveled output power typically degrades .1 dB/°C.
- 4 When RF Output is peaked with PEAK control.
- 5 0.5 dB lower for Option 004.
- 6 Attenuator switch points are every 10 dB starting at -5 dBm indicated power.
- 7 Discontinuity at 2.4 GHz bandswitch point is typically (0.25 dB.
- 8 Excludes coupler and detector variation. Crystal detector output should be between -10 mV and -200 mV at specified maximum leveled power.
- 9 Use HP Model 432A/B/C Power Meter. Sweep time 100 seconds; typically ≥ 5 seconds/GHz but not ≤ 10 seconds.
- 10 Power Sweep and Slope Compensation total must not exceed 15 dB (13 dB above 18.6 GHz).
- 11 With Option 002, in power sweep or slope functions, power can exceed attenuator step by 5 dB (3 dB above 18.6 GHz).
- 12 Includes power level variations.

Table 1-2. Supplemental Performance Characteristics for Model 83592A
Installed in Model 8350A (1 of 4)

NOTE

Values in this table are not specifications, but are typical characteristics included for user information.

FREQUENCY CHARACTERISTICS¹

<u>Frequency Bands (GHz)</u>	.01 to 2.4	2.4 to 7.0	7.0 to 13.5	13.5 to 20.0	0.01 to 20.0
<u>Accuracy</u> (25°C ±5°C)					
CW Mode Typically:	±2 MHz ²	±2 MHz	±3 MHz	±4 MHz	
Manual Sweep:	≤15 MHz	≤30 MHz	≤30 MHz	≤30 MHz	≤100 MHz
All Sweep Modes: (Sweep time 10 ns to 100 ns)	≤±5 MHz	≤±6 MHz	≤±8 MHz	≤±10 MHz	≤±35 MHz
Sweep Mode Linearity ³ :	≤±2 MHz	≤±2 MHz	≤±4 MHz	≤±6 MHz	≤±10 MHz
<u>Stability with Temperature:</u>	±200 kHz/°C	±200 kHz/°C	±400 kHz/°C	±600 kHz/°C	±600 kHz/°C

Table 1-2. Supplemental Performance Characteristics for Model 83592A
Installed in Model 8350A (2 of 4)

OUTPUT CHARACTERISTICS¹

Power Output

Resolution (Displayed): 0.1 dB

Resolution (Power): Typically ± 0.01 dB

Stability with Temperature (at Specified Maximum Levelled Power): ± 0.1 dB/ $^{\circ}$ C

Power Variation

(at specified Maximum Levelled Power or below)

Externally levelled with Negative Crystal Detector: ± 0.25 dB⁶
(Sweep time 10 ms to 100 ms)

<u>Frequency Bands (GHz)</u>	.01 to 2.4	2.4 to 7.0	7.0 to 13.5	13.5 to 20.0	.01 to 20.0
------------------------------	------------	------------	-------------	--------------	-------------

Spurious Signals

(in dB below carrier and at specified maximum levelled power)

Harmonics and Subharmonics:	>35 dB	>40 dB	>35	>35	>35
Non Harmonics Typically	>40 dB	>55 dB	55 dB	>55 dB	>40 dB

Impedance: 50 Ohms

Power Sweep⁴

Accuracy (Including Linearity): Typically ± 1.5 dB

Resolution (Displayed): 0.1 dB

Slope Compensation⁴

Linearity: Typically <0.2 dB

Calibrated Range⁵: Up to 5 dB/GHz; up to 15 dB for full sweep range

Resolution (Displayed): 0.01 dB/GHz

Table 1-2. Supplemental Performance Characteristics for Model 83592A
Installed in Model 8350A (3 of 4)

MODULATION CHARACTERISTICS

External AM

Frequency Response: Typically 100 kHz
Input Impedance: Approximately 10k Ohm
Range of Amplitude Control: Typically 15 dB
Sensitivity: Typically 1 dB/V

Pulse In

TTL compatible: Logic high = RF on, Logic low = RF off
7.0 to 20.0 GHz: Squarewave modulation up to 30 kHz
.01 to 7.0 GHz:
Rise/Fall Time: Typically 10 ns
Minimum Pulse Width:
 Leveled: Typically 1 us
 Unleveled Power level set to +20 dBm: Typically 100 ns

External FM

Frequency Response (DC to 2 MHz): Typically ± 3 dB
Sensitivity (Switch selectable)
 Typically -20 MHz/V (FM Mode)
 Typically -6 MHz/V (Phase-Lock Mode)
Input Impedance: 2000 Ohms nominal

Table 1-2. Supplemental Performance Characteristics for Model 83592A
Installed in Model 8350A (4 of 4)

GENERAL CHARACTERISTICS¹

Frequency Reference Output: 1 V/GHz ± 25 mV (0.01 to 19 GHz) rear panel BNC output.

Auxiliary Output: Rear Panel 2.3 to 7 GHz fundamental oscillator output, nominally 0 dBm.

Weight: Net 6.0 kg (13.2 lb.), Shipping 9.2 kg (20 lb.)

-
- 1 Unless otherwise noted, all characteristics are at the RF OUTPUT connector and at 0° to 55°C.
 - 2 Accuracy when calibrated with the FREQ CAL adjustment.
 - 3 With respect to the SWEEP OUT voltage.
 - 4 Power Sweep and Slope Compensation must not exceed 15 dB (13 dB above 18.6 GHz).
 - 5 With Option 002, in power sweep or slope functions, power can exceed attenuator step by 5 dB (3 dB above 18.6 GHz).
 - 6 Excludes coupler and detector variation. Crystal detector output should be between -10 mV and -200 mV at specified maximum leveled power.

1-16. DESCRIPTION

1-17. The Model 83592A is an RF plug-in which has been designed for use with the Model 8350A Sweep Oscillator. The Model 83592A covers the frequency range of 0.01 to 20.0 GHz in four bands. A YIG oscillator is used as the tunable RF frequency source for all bands. The lowest band (Band 0) uses a fixed 3.8 GHz oscillator which is mixed with the YIG oscillator to generate a 0.1 to 2.4 GHz RF output. The YIG oscillator fundamental frequency is used for Band 1 (2.3 to 7.0 GHz). A YIG Tuned Multiplier (YTM) is used to multiply the YIG oscillator frequency for Bands 2 and 3 (6.9 to 13.5 GHz and 13.4 to 20.0 GHz).

1-18. Model 83592A front panel functional controls, pushbuttons, and the Rotary Pulse Generator (RPG), are monitored by the Model 8350A via the RF plug-in interface circuits. The Model 8350A generates a tuning voltage according to the mode of operation (CW, START/STOP, CF/ Δ F). This signal is scaled and offset by the plug-in to provide a voltage ramp (in swept modes) proportional to the YIG oscillator frequency. The Model 83592A tuning circuits accept the tuning ramp output from the Model 8350A and convert it to a current which drives the YIG oscillator tuning coil.

1-19. The Model 83592A offers a maximum leveled RF output power of +10 dBm. Internal (INT), External (EXT), and Power Meter (MTR) leveling is available as selected by the front panel pushbuttons. A front panel EXT/MTR ALC input connector and gain control (CAL) are provided to use with an external leveling loop. A front panel LED indicates when the RF output becomes unlevelled. The RF output level is controlled by the Model 83592A RPG, the Model 8350A data entry controls (keypad and step keys), or through HP-IB control via the Model 8350A.

1-20. A power sweep function allows the RF output power to be swept at least 10 dB during CW mode or swept frequency modes. Power sweep is selected by the front panel POWER SWEEP pushbutton. Slope compensation control is also available by selecting the SLOPE pushbutton and rotating the Model 83592A RPG or manipulating the Model 8350A data entry controls. The power sweep function and slope compensation may both be selected and modified through HP-IB control via the Model 8350A.

1-21. The RF output may be internally or externally amplitude modulated, or externally frequency modulated. Internal square wave modulation frequency is selectable by a Model 8350A internal jumper to be either 1 kHz or 27.8 kHz

(for use with the Model 8755 Swept Amplitude Analyzer). Rear panel BNC connectors accept an external AM or FM frequency. FM coupling (direct coupled or cross-over) and sensitivity is selected by an internal configuration switch in the Model 83592A. Refer to Section III Operation of this manual for detailed information on the configuration switch.

1-22. A rear panel 1V/GHz signal corresponds to the RF output frequency. This output voltage may be used as a reference for pretuning external equipment in phase locking applications. (The Model 8410B/8411A Network Analyzer utilizes this output in such a configuration.)

1-23. The RF output may be turned off by the RF ON/OFF pushbutton. RF power ON is indicated by the LED in the center of the pushbutton. Additionally, in CW mode, the CW FILTER, when selected, places a capacitor across the YIG oscillator tuning coil to filter high frequency noise which would appear at the RF output. All front panel functions, with the exception of the FREQ CAL and EXT/MTR ALC CAL adjustments, may be set or altered by computer control via the HP-IB bus connection on the Model 8350A.

1-24. OPTIONS

1-25. Option 002, 70 dB Attenuator

1-26. Option 002 instruments contain a digitally controlled attenuator just before the RF output. Up to 70 dB of attenuation in 10 dB steps is automatically selected as required to attenuate the RF output power to the indicated level. The continuously variable power level function operates as in a standard instrument with the data entry controls.

1-27. Option 004, Rear Panel RF Output

1-28. Option 004 instruments have the Type N RF output connector and the BNC EXT/MTR ALC input connector on the rear panel instead of the front panel.

1-29. Option 005, APC--7 RF Output Connector

1-30. Option 005 instruments have an APC--7 RF Output connector.

1-31. EQUIPMENT REQUIRED BUT NOT SUPPLIED

1-32. To have a complete operating sweep oscillator unit, the Model 83592A RF plug-in must be installed in a Model

8350A Sweep Oscillator. Refer to Section II Installation in this manual for a detailed description of RF plug-in installation.

1-33. EQUIPMENT AVAILABLE

1-34. Service Accessories

1-35. A Service Accessory Kit (HP Part Number 08350-60020) is available for servicing the Model 83592A RF plug-in and the Model 8350A Sweep Oscillator. HP Part Numbers for the individual pieces of the kit are provided in Table 1-3. The accessory kit includes:

- Two 44-pin printed circuit board extenders. These boards have keyed slots which allow them to be used in each of the keyed pc board receptacles in the Model 83592, and in the Model 8350A as well.
- An RF Plug-in extender cable set that provides all electrical connections when the RF Plug-in is removed from the sweep oscillator. The RF Plug-in Interface connector (P2) and the Power Supply Interface connector (P1) are extended by separate cables.
- One Hex Balldriver for use in Model 8350A front panel repairs.
- One 16-pin and one 20-pin I.C. Test Clip for probing integrated circuits.

1-36. A listing of service accessories available including service cables, wrenches, adapters, and extender boards is given in Table 1-3.

1-37. Model 8410B/8411A Network Analyzer

1-38. The Model 8350A Sweep Oscillator, with the Model 83592A RF Plug-in installed, is compatible with the HP Model 8410B Network Analyzer system. The combination of the Model 8410B Network Analyzer, the Model 8411A Frequency Converter, and an appropriate display plug-in forms a phasemeter and a ratiometer for direct phase and amplitude ratio measurement on RF voltages. These measurements can be made on single frequencies and on swept frequencies from 110 MHz to 18 GHz. The Model 8350A/83592A combination is capable of operation over this full frequency range. The Model 8410B has an Auto-Frequency range mode which gives it the capability of automatically tracking the Model 8350A Sweep Oscillator over octave and multi-octave frequency bands. Two interconnections

to the Model 8350A are necessary to ensure that the Model 8410B will phase lock properly. The Model 8410B Source Control Cable (HP 08410-60146) connects the Model 8410B rear panel SOURCE CONTROL connector to the Model 8350A rear panel PROGRAMMING CONNECTOR. Additionally, the Model 83592A RF Plug-in rear panel 1V/GHz output connects to the Model 8410B rear panel FREQ REF INPUT. The Model 8410B Source Control Cable connector pins and signals are illustrated in the Model 8350A Sweep Oscillator Operating and Service Manual.

1-39. Model 8755 Frequency Response Test Set

1-40. The Model 8350A Sweep Oscillator with the Model 83592A RF Plug-in installed is compatible with the Model 8755 Frequency Response Test Set for broadband swept scalar measurements. The Model 8350A provides internal 27.8 kHz square wave amplitude modulation of the RF output, eliminating unnecessary cable connections to the Model 8755 or the use of an external modulator. The Model 8350A can also produce alternate sweeps through use of the ALT n function which works in conjunction with the channel switching circuits in the Model 8755C. This permits Channel 1 on the Model 8755C to respond only to the Model 8350A current state and Channel 2 to the alternate state. A single cable (HP Part Number 8120-3174) connects between the Model 8350A rear panel ALT SWP INTERFACE connector and the Model 8755C front panel ALT SWP INTERFACE connector.

1-41. Power Meters and Crystal Detectors

1-42. The RF output can be externally leveled using the HP Model 432 Power Meter or negative polarity output crystal detectors. Refer to Section III Operation of this manual for detailed information on leveling techniques that may be used with the Model 8350A/RF Plug-in combination.

NOTE

The Model 435A and 436A Power Meters should not be used in Model 8350A/Model 83592A external leveling systems.

1-43. RECOMMENDED TEST EQUIPMENT

1-44. Equipment required for testing and adjusting the instrument is listed in Table 1-4. Other equipment may be substituted if it meets or exceeds the critical specifications indicated in the table.

Table 1-3. Service Accessories Available

NAME	HP PART NUMBER	DESCRIPTION
44-pin printed circuit board extender	08350-60031*	Extends printed circuit boards
RF Plug-in Extender Cables	08350-60034* 08350-60035*	Extends RF Plug-in Interface connector (P2) Extends RF Plug-in Power Supply Interface connector (P1)
Adjustment Tool	8830-0024	Fits miniature adjustment slot on potentiometers
Wrenches	08555-20097 8710-0946	5/16" slotted box/open end 15/64" open end
Service Cables	8120-1578 83525-60019	18" coax with SMA (m) connector on each end 10" coax with SMB snap on (f) and SMA (m)
Adapters	1250-0777 1250-0082 1250-1404 1250-1158 1250-0674 1250-0675 1250-0069	Type N (f) to BNC (m) Type N (m) to BNC (m) Type N (f) to SMA (f) SMA (f) to SMA (f) SMA (f) to SMB (m) SMA (f) to SMC (m) SMB snap on (m) to SMB snap on (m)
Hex Balldriver	8710-0523*	Removes front panel hold down plate hex screws in 8350A
IC Test Clip	1400-0734* 1400-0979*	16-pin IC test clip 20-pin IC test clip
*These items are included in a Service Accessories Kit HP Part No. 08350-60020 (2 board extenders are included in this kit).		

Table 1-4. Recommended Test Equipment

<u>Instrument</u>	<u>Critical Specifications</u>	<u>Recommended Model</u>	<u>Use*</u>
Sweep Oscillator	No substitute	HP 8350A	P,A,T
Digital Voltmeter (DVM)	Range: -50V to +50V Accuracy: $\pm 0.01\%$ Input Impedance: $\geq 10M$ Ohms	HP 3455A	P,A,T
Oscilloscope	Dual Channel Bandwidth: dc to 100 MHz Vertical Sensitivity: ≤ 5 mV/DIV Horizontal Sweep Rate: $\leq 0.1\mu S/DIV$ External Sweep Capability	HP 1740A	P,A,T
Oscilloscope Probe	1:1 General Purpose Probe	HP 10008B	A
Frequency Counter	Frequency Range: 0.01 to 20.0 GHz Input Impedance: 50 Ohms Resolution: ≤ 1 MHz	HP 5343A	P,A
Spectrum Analyzer	Frequency Range: 0.01 to 20.0 GHz Residual FM: ≤ 100 Hz	HP 8565A or HP 8566A	P,T
Swept Amplitude Analyzer	Capable of Transmission Measurements. Power Resolution: ≤ 0.25 dB	HP 8755C	P,A
Display Mainframe	Compatible with 8755C Swept Amplitude Analyzer	HP 180T/TR, 182T/TR	P,A
Detector	Compatible with Swept Amplitude Analyzer Frequency Range: 0.01 to 20.0 GHz Power Range -20 to +10 dBm	HP 11664B	P,A
Frequency Meter	Frequency Accuracy: $\leq 0.17\%$ Calibration Increments: ≤ 2 MHz Frequency Range: 0.96 to 4.0 GHz 4.0 to 12.4 GHz 12.4 to 18 GHz	HP 536A HP 537A HP P532A	P,A P,A A
Function Generator	Frequency Range: 0.1 Hz to 10 MHz Sinewave and squarewave output Output Level: 10Vp-p into 50 Ohms Output Level Flatness: $\leq +3\%$ from 10 Hz to 100 kHz $\leq +10\%$ from 100 kHz to 10 MHz	HP 3312A	P,A,T

Table 1-4. Recommended Test Equipment

<u>Instrument</u>	<u>Critical Specifications</u>	<u>Recommended Model</u>	<u>Use*</u>
Power Meter	Power Range: -20 to +10 dBm (No substitute when used for external power meter leveling).	HP 432A	P,A
Thermistor Sensor	Frequency Range: 0.01 to 18 GHz Maximum SWR: ≤ 1.75	HP 8478B	P,A
Thermistor Sensor	Frequency Range: 18 to 20.0 GHz Maximum SWR: ≤ 2.0	HP K486	A
Adaptor	Waveguide to APC 3.5 (f) (for use with HP K486)	HP K281C	A
Power Meter	Power Range: 1 μ W to 100 mW	HP 436A	P,A
Power Sensor	Frequency Range: 0.01 to 20.0 GHz	HP 8485A	P,A
Crystal Detector	Frequency Response: 0.01 to 20.0 GHz Maximum Input Power: 100 mW	HP 8473C	P,A
Attenuator†	Frequency Range: 0.01 to 20 GHz Maximum Input Power: +20 dBm Attenuation: 20 dB ± 1.0 dB 10 dB ± 0.8 dB 6 dB ± 0.6 dB 3 dB ± 0.5 dB	Weinschel Model M9-20 Weinschel Model M9-10 Weinschel Model M9-6 Weinschel Model M9-3	P P,A P P
Power Splitter	Frequency Range: 0.01 to 20.0 GHz Maximum Input Power: $\leq +20$ dBm	Weinschel Model 1579A	P,A

Table 1-4. Recommended Test Equipment

<u>Instrument</u>	<u>Critical Specifications</u>	<u>Recommended Model</u>	<u>Use*</u>
Directional Coupler	Frequency Range: 0.1 to 2.0 GHz Nominal Coupling: ≥ 20 dB Maximum Coupling Variation: $\leq +1$ dB Minimum Directivity: ≥ 32 dB	HP 778D	P
Directional Coupler	Frequency Range: 2.0 to 18 GHz Nominal Coupling: ≥ 22 dB Maximum Coupling Variation: ± 1 dB Minimum Directivity: 26 dB	HP 11692D	P
RMS Voltmeter	dB Range: -20 to -70 dBm (0 dBm = 1 mW into 600 ohms) Frequency Range: 10 Hz to 10 MHz Accuracy: $\pm 5\%$ of full scale	HP 3400A	P
Air Line Extension (2 required)	Impedance: 50 Ohms Frequency Range: dc to 18 GHz Reflection Coefficient: 0.018 + 0.001 (times the frequency in GHz)	HP 11567A	P
Step Attenuator	Frequency Range: dc to 18 GHz Incremental Attenuation 0 to 70 dB in 10 dB steps Calibration Accuracy: $\leq +0.1$ dB at all steps	HP 8495B Option 890	P
Adjustable Short	Frequency Range: 1.1 to 18 GHz Impedance: 50 ± 1.5 ohms	Mauvy Microwave 1953-2	P
DC Power Supply	DC Output: 0 to 6.5Vdc ± 0.05 Vdc	HP 6213A	A
50 Ohm Termination	Type N, 50 ± 0.5 Ohms	HP 909A	P
Delay Line Discriminator	Refer to Figure 1-3.		P,A
PC Board Extender	44-pin, extends printed circuit boards	HP Part No. 08350-60031	A,T

*P = Performance Test; A = Adjustments; T = Troubleshooting

†For testing at frequencies of ≤ 18 GHz, the following attenuators may be substituted:

- 20 dB HP 8491B Option 020
- 10 dB HP 8491B Option 010
- 6 dB HP 8491B Option 006
- 3 dB HP 8491B Option 003

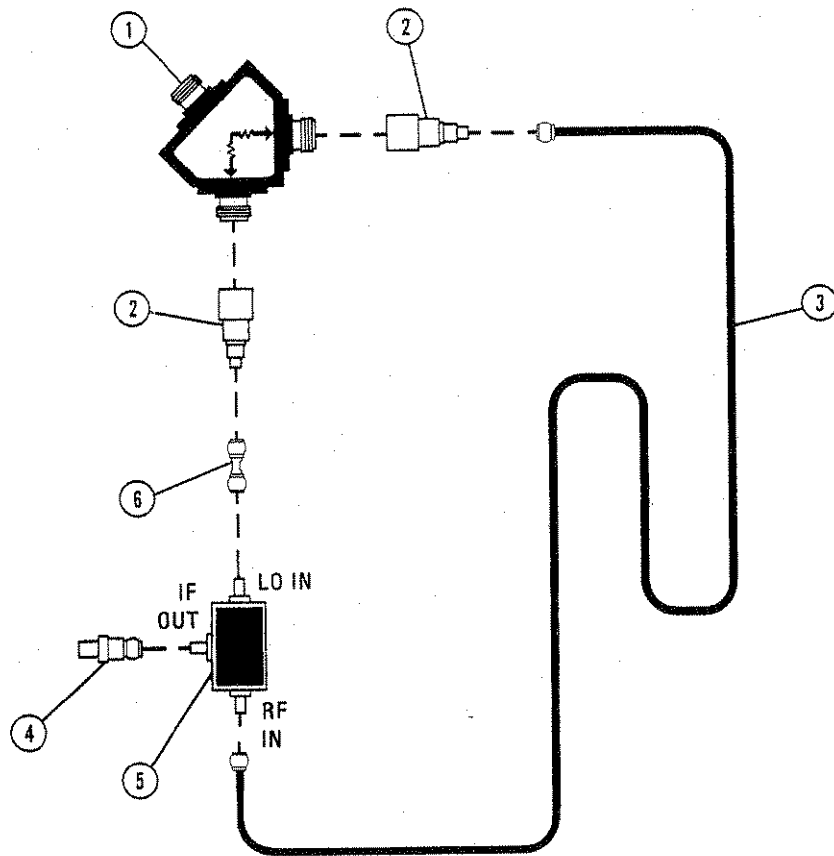

Item	Description	HP Part Number
1	Power Splitter	HP 11667A
2	Adapter: Type N Male to SMA Female (2 required)	1250-1250
3	Delay Line: >1 meter in length, SMA male connectors	08503-20038
4	Adapter: BNC Female to Male SMA	1250-1200
5	Mixer: Double Balanced 1 to 12 GHz: RHG Electronics Part No. DM 1-12 1 to 18 GHz: RHG Electronics Part No. DM 1-18 RHG Electronics Laboratories, Inc. Deer Park, NY 11729	0960-0451 None
6	Adapter: SMA Male to SMA Male	1250-1159

Figure 1-3. Delay Line Discriminator

SECTION II
INSTALLATION

2--1. INTRODUCTION

2--2. This section provides installation instructions for the Model 83592A RF Plug--in. This section also includes information about initial inspection, damage claims, preparation for use, packaging, storage, and shipment.

2--3. INITIAL INSPECTION

2--4. Inspect the shipping container for damage. If the shipping container or cushioning material is damaged, it should be kept until the contents of the shipment have been checked for completeness and the instrument has been checked mechanically and electrically. The contents of the shipment should be as shown in Figure 1--1. Procedures for checking electrical performance are given in Section IV, Performance Tests, of this Operating and Service Manual. If the instrument combination does not pass the electrical Performance Tests, refer to Section V, Adjustments, of this manual. If, after the adjustments have been made, the instrument combination still fails to meet specifications, and a circuit malfunction is suspected, refer to troubleshooting procedures in Section VIII, Service, in this manual. If the instrument does not pass the above electrical tests, if the shipment contents are incomplete, or if there is mechanical damage or defect, notify the nearest Hewlett--Packard office. If the shipping container is damaged, or if the cushioning material shows signs of stress, notify the carrier as well as the Hewlett--Packard office. Keep the shipping materials for carrier's inspection. The HP office will arrange for repair or replacement without waiting for claim settlement.

2--5. PREPARATION FOR USE

2--6. Power Requirements

2--7. When the Model 83592A RF Plug--in is properly installed, it obtains all power through the rear panel interface connector from the Model 8350A Sweep Oscillator.

2--8. RF Plug--in Configuration Switch

2--9. The Model 83592A RF Plug--in has a configuration switch (A3S1) located on the A3 Digital Interface Board. This switch must be preset prior to RF Plug--in operation in the Model 8350A. The configuration switch is an 8--section multiple switch. Each separate switch corresponds to a separate RF plug--in function

such as FM sensitivity selection, FM input coupling selection (direct coupled or cross--over), RF power level at power on (maximum or off), and Option 002 Step Attenuator operation. Refer to Section III, Operation, in this manual for a complete description of the configuration switch and instructions on how to set the switches.

2--10. Interconnections

2--11. There are two rear panel interconnections from the Model 83592A RF Plug--in to the Model 8350A Sweep Oscillator. These are the RF Plug--in Interface connector (P2) and the Power Supply Interface Connector (P1). A complete listing of pins and associated signals for these connectors is provided in Figures 2--1 and 2--2.

2--12. Mating Connectors

2--13. All of the externally mounted connectors on the Model 83592A are listed in Table 2--1. Opposite each connector is an industry identification, the HP part number of a mating connector, and the part number of an alternate source for the mating connector. For HP part numbers of the externally mounted connectors themselves, refer to Section VI, Replaceable Parts, of this manual.

Table 2-1. Mating Connectors

83592A Connector		Mating Connector	
Connector Name	Industry Identification	HP Part No.	Alternate Source
J1 RF INPUT	Type N (f)	1250-0882	Specialty Connector 25-P117-2
J2 EXT/MTR ALC INPUT	BNC (f)	1250-0256	Specialty Connector 25-P118-1
J3 AUX OUTPUT	Type N (f)	1250-0882	Specialty Connector 25-P117-2
J4 PULSE IN	BNC (f)	1250-0256	Specialty Connector 25-P118-1
J5 1V/GHz	BNC (f)	1250-0256	Specialty Connector 25-P118-1

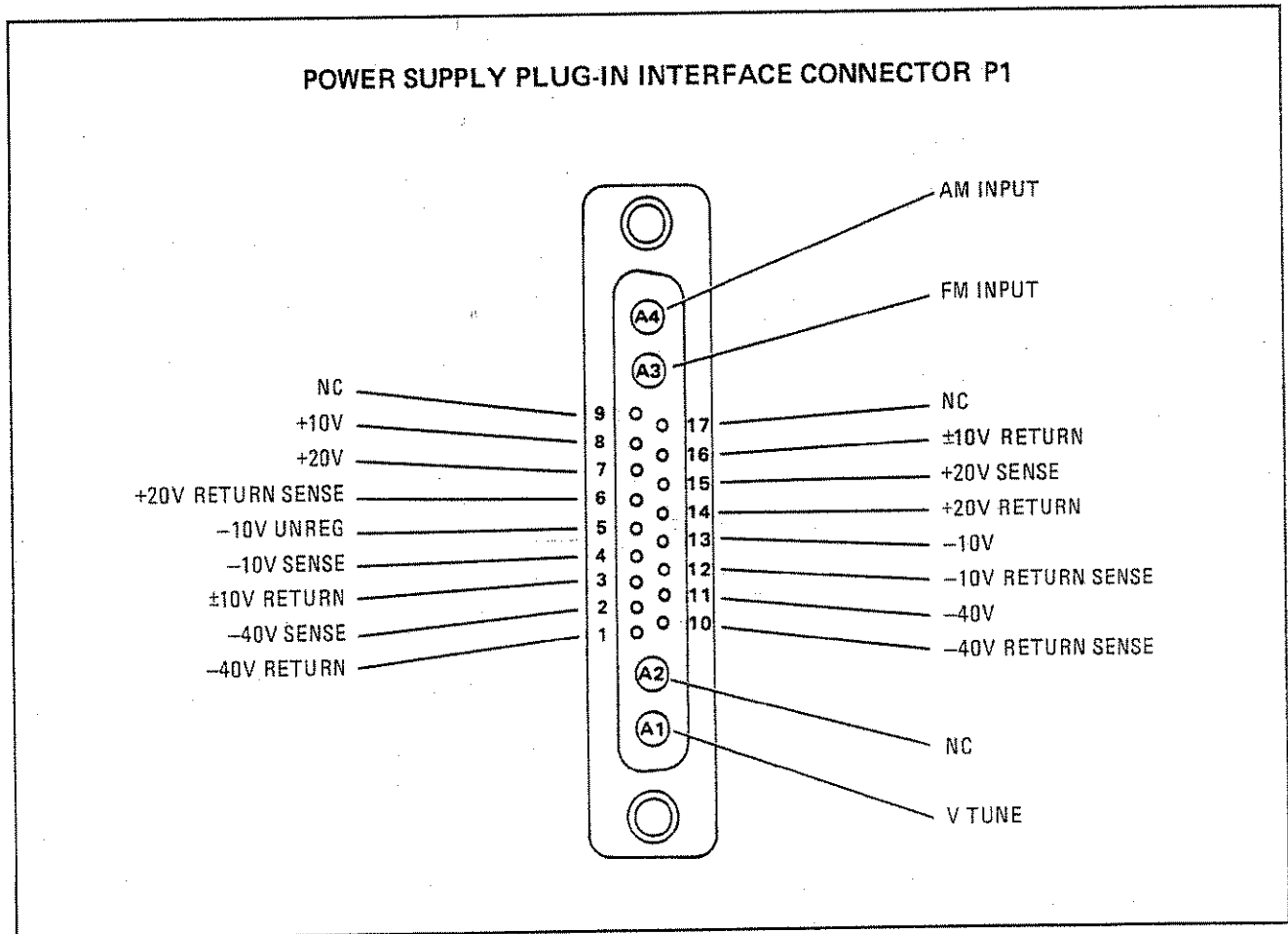

Figure 2-1. Interface Signals on Connector P1

PLUG-IN INTERFACE CONNECTOR P2

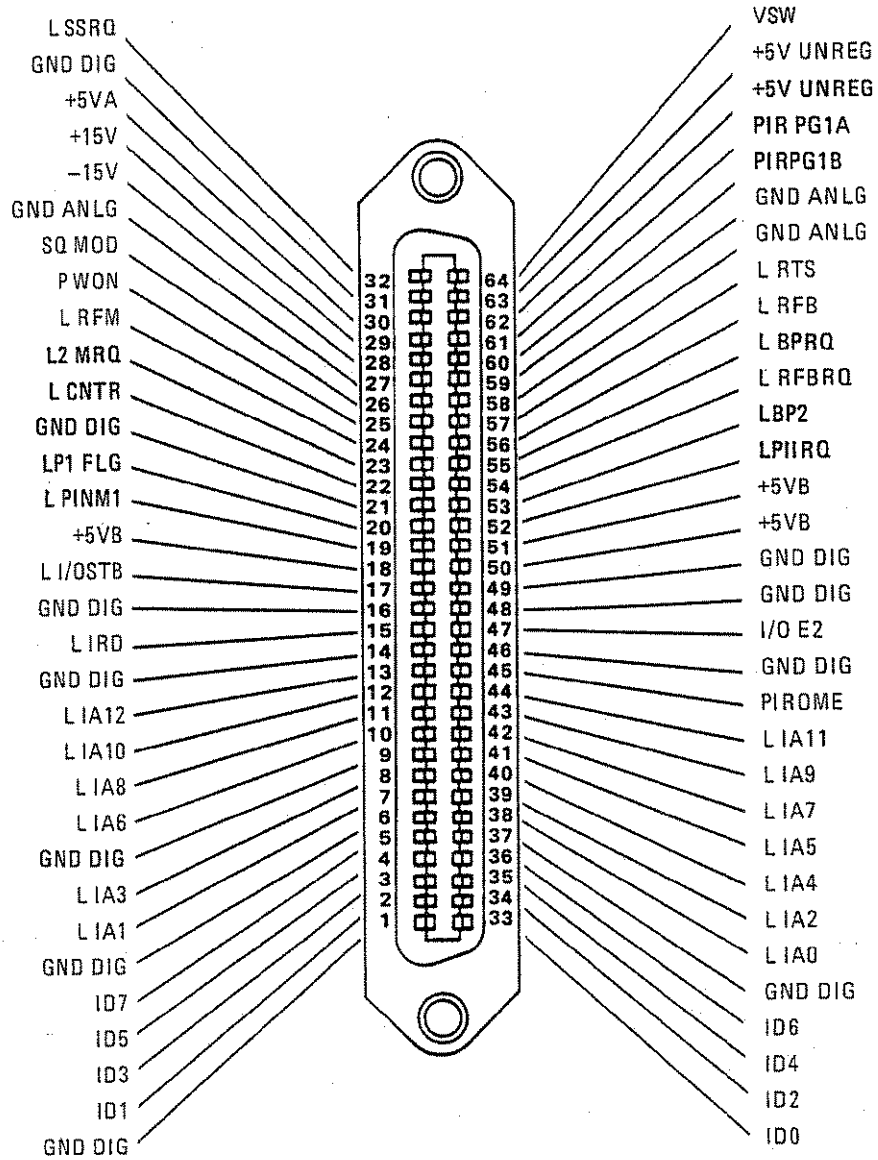

Figure 2-2. Interface Signals on Connector P2

2--14. Operating Environment

2--15. Temperature. The instrument may be operated in temperatures from 0°C to +55°C.

2--16. Humidity. The instrument may be operated in environments with humidity from 5% to 80% relative at +25°C to +40°C. However, the instrument should also be protected from temperature extremes which cause condensation within the instrument.

2--17. Altitude. The instrument may be operated at altitudes up to 4572 meters (15,000 feet).

2--18. Cooling. When the Model 83592A RF Plug--in is properly installed in the Model 8350A Sweep Oscillator, it obtains all of its cooling airflow by forced ventilation from the fan in the Model 8350A. A diagram showing the various cooling airflow paths within the sweep oscillator is given in Section II, Installation, of the Model 8350A Sweep Oscillator Operating and Service Manual. Ensure that all airflow passages in the Model 8350A and the Model 83592A are clear before installing the RF Plug--in in the Sweep Oscillator.

2--19. Installation Instructions

2--20. To operate as a completely functional sweep oscillator, the Model 83592A RF Plug--in must be installed in a Model 8350A Sweep Oscillator. To install the Model 83592A RF plug--in in the Model 8350A Sweep Oscillator:

- a. Set the Model 8350A mainframe LINE switch to OFF.
- b. Remove all connectors and accessories from the front and rear panel connectors of the Model 83592A to prevent them from being damaged.
- c. Position the RF plug--in unit latching handle in the fully raised position. The latching handle should spring easily into the raised position and be held by spring tension.
- d. Ensure that the Model 8350A RF plug--in channel is clear, align the RF plug--in in the channel and slide it carefully into place toward the rear of the channel. It should slide easily without binding.
- e. The drawer latch handle slot will engage with the locking pin just before the RF plug--in is fully seated in position.
- f. Press the latch handle downward, while still pushing in on the

RF plug--in, until the drawer latch is fully closed and the front panel of the RF plug--in is aligned with the sweep oscillator front panel.

2--21. STORAGE AND SHIPMENT

2--22. Environment

2--23. The instrument may be stored or shipped in environments within the following limits:

Temperature	-40°C to +75°C
Humidity	5% to 95% relative at 0°C to +40°C
Altitude	Up to 15240 meters (approximately 50,000 feet)

2--24. The instrument should also be protected from temperature extremes which may cause condensation in the instrument.

2--25. Packaging

2--26. Original Packaging. Containers and materials identical to those used in factory packaging are available through Hewlett--Packard offices. A complete diagram and listing of packaging materials used for the Model 83592A is shown in Figure 2--3. If the instrument is being returned to Hewlett--Packard for servicing, attach a tag indicating the type of service required, return address, model number, and full serial number (located on rear panel serial plate). Mark the container FRAGILE to assure careful handling. In any correspondence, refer to the instrument by model number and full serial number.

2--27. Other Packaging. The following general instructions should be used for repackaging with commercially available packaging materials:

- a. Wrap the instrument in heavy paper or plastic. If shipping to a Hewlett--Packard Office or Service Center, attach a tag indicating the type of service required, return address, model number, and full serial number.
- b. Use a strong shipping container.
- c. Use enough shock--absorbing material around all sides of the instrument to provide a firm cushion and to prevent movement inside the container. Protect the control panel with cardboard.
- d. Seal the shipping container securely.

e. Mark the shipping container FRAGILE to assure careful handling.

f. In any correspondence, refer to the instrument by model number and full serial number.

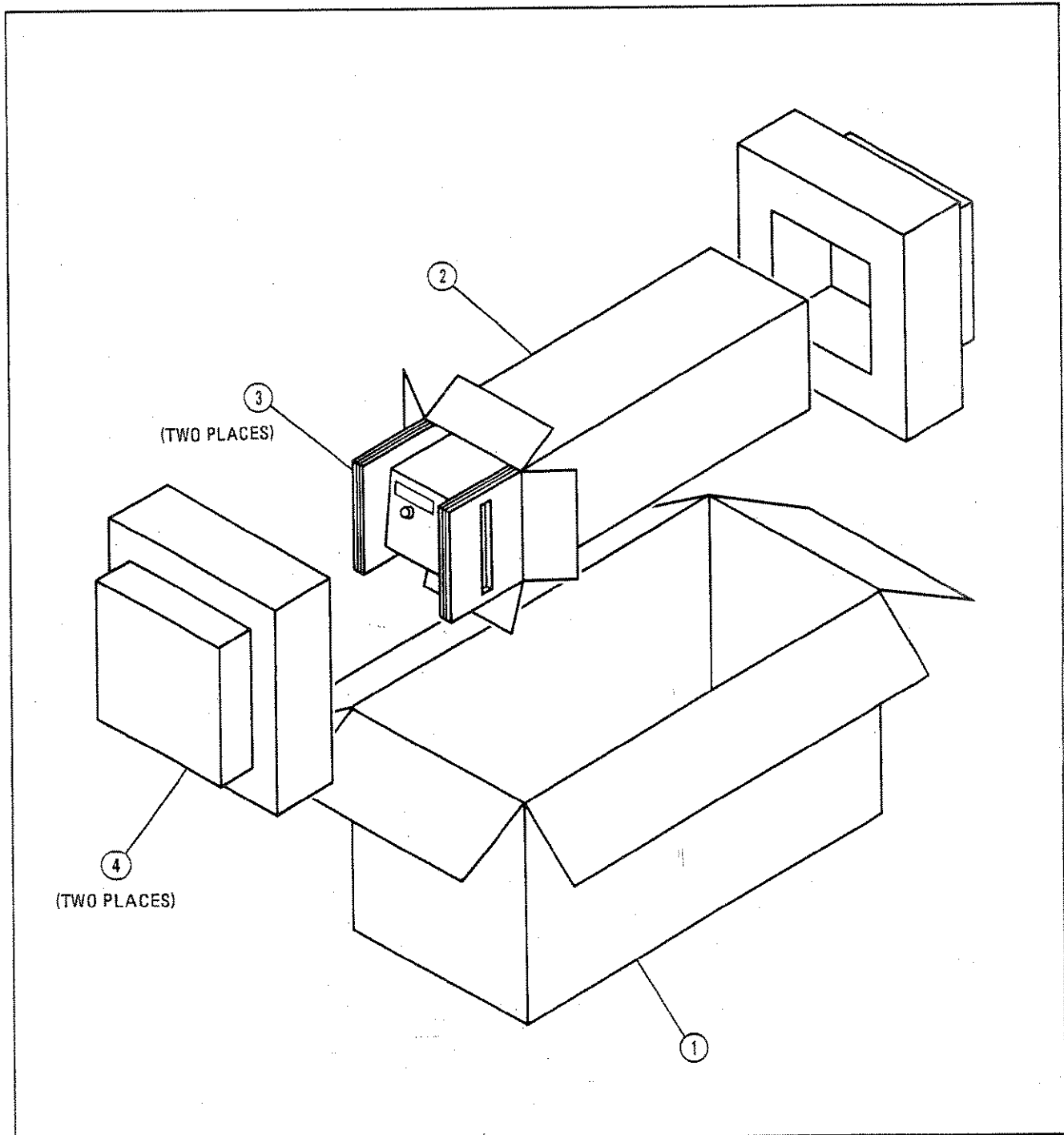

Item	Quantity	HP Part Number	C D	Description
1	1	9211-3515	6	Outer Carton
2	1	9211-3514	5	Inner Carton
3	2	9220-3409	6	Side Pads -- Corrugated Cardboard
4	2	9220-3406	3	Foam Pads
	1	9222-0352	6	Poly Bag -- to cover instrument

Figure 2-1. Packaging for Shipment Using Factory Packaging Materials

SECTION III

OPERATION

3-1. INTRODUCTION

3-2. This section is divided into four major sections. Operating Characteristics explains the bandswitching and frequency resolution characteristics in CW and swept modes. Front and rear panel Panel Features are shown with illustrated descriptions. Operating Instructions provide a front panel frequency calibration procedure, configuration switch setting instructions, and crystal detector and power meter leveling instructions. Operator's Maintenance includes information on the plug-in error codes, fuses, and service tags.

3-3. OPERATING CHARACTERISTICS

3-4. Bandswitching And Resolution

3-5. The following paragraphs describe the bandswitching and frequency resolution characteristics of the 83592A RF Plug--in.

3-6. The 83592A 10 MHz to 20 GHz RF output is provided in four bands. When sweeping a range of frequencies larger than a single band, the switching between these bands is done automatically. Careful selection of sweep frequencies may avoid problems associated with bandswitching such a harmonics, sweep time, stability, or switching discontinuities. Figure 3--1 illustrates the bandswitching points in the sequential and single band sweep modes.

3-7. Two areas relating to frequency resolution must be considered; these are input resolution and displayed resolution. Input resolution refers to the number of bits (8 bits = 256 points) in the digital to analog converter (DAC) used to generate the tuning voltage for a particular mode of operation. Table 3-1 cross references input resolution with each DAC used. Displayed frequency resolution refers to the number of digits shown on the 8350A FREQUENCY displays.

3-8. Figure 3-2 is a simplified block diagram of the frequency tuning circuits. The net tuning voltage results from the summation of the three DAC outputs. With this DAC configuration the START/STOP sweep mode is computed by the microprocessor into a center frequency and a ΔF sweep width. Therefore the operation of all sweeps are set with a center

Table 3-1. Input Resolution

DAC Used	Voltage Resolution	Frequency Resolution				
		Band 0 0.01 to 2.4 GHz	Band 1 2.4 to 7.0 GHz	Band 2 7.0 to 13.5 GHz	Band 3 13.5 to 20 GHz	Full Sweep 0.01 to 20 GHz
CF	2.5 mV	0.607 MHz	1.17 MHz	1.65 MHz	1.65 MHz	5.08 MHz
Vernier	40 μ V	9.48 kHz	18.25 kHz	25.78 kHz	25.78 kHz	79.38 kHz
ΔF 1-1/8 of band	10 mV	2.43 MHz	4.67 MHz	6.60 MHz	6.60 MHz	20.30 MHz
ΔF 1/8-1/64 of band	1.25 mV	0.303 MHz	.584 MHz	.825 MHz	.825 MHz	2.54 MHz
ΔF 1/64 of band	0.156 mV	37.9 kHz	73.0 kHz	103.2 kHz	103.2 kHz	317.2 kHz

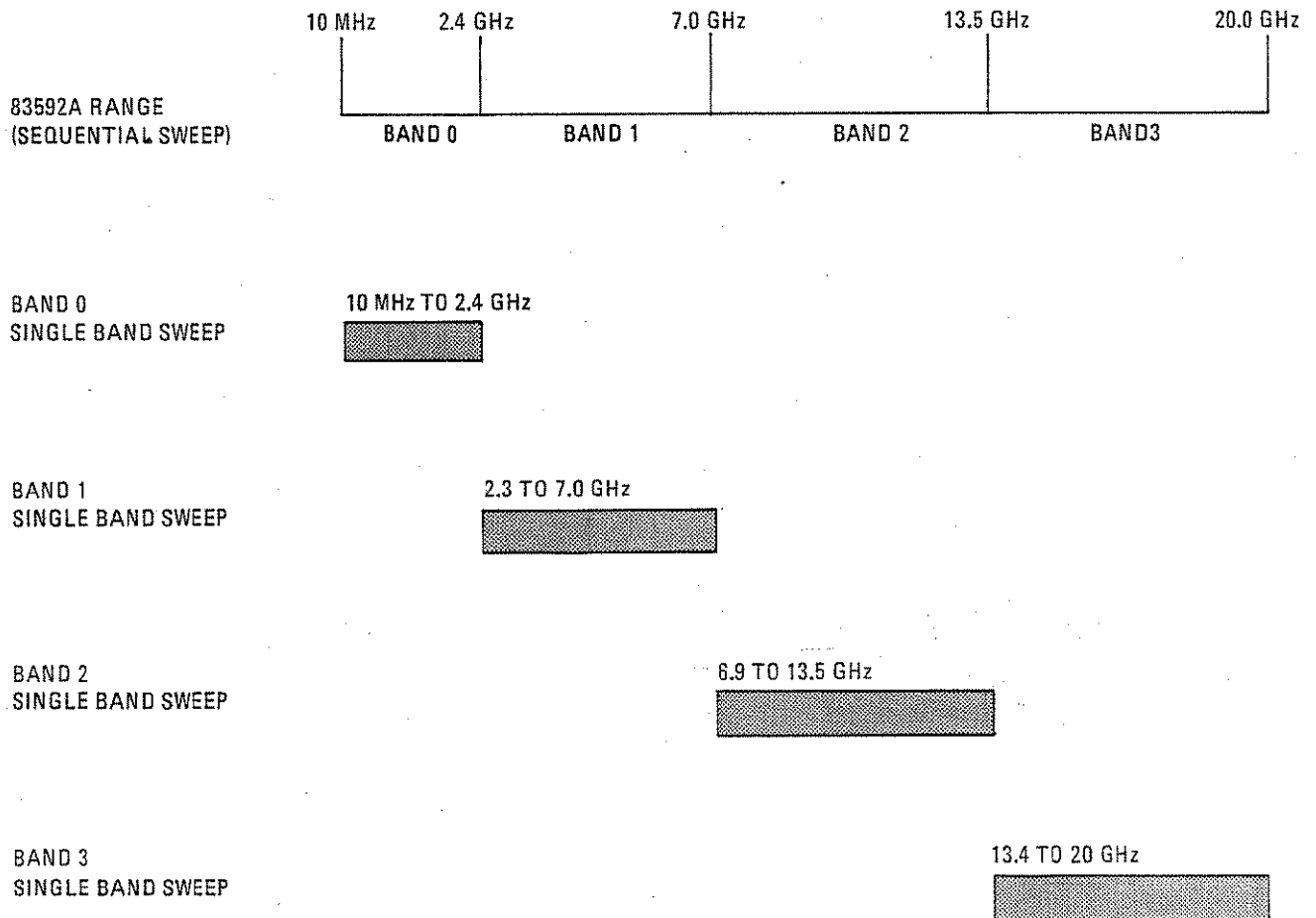

Figure 3-1. Bandswitching in Sequential and Single band Sweep Modes.

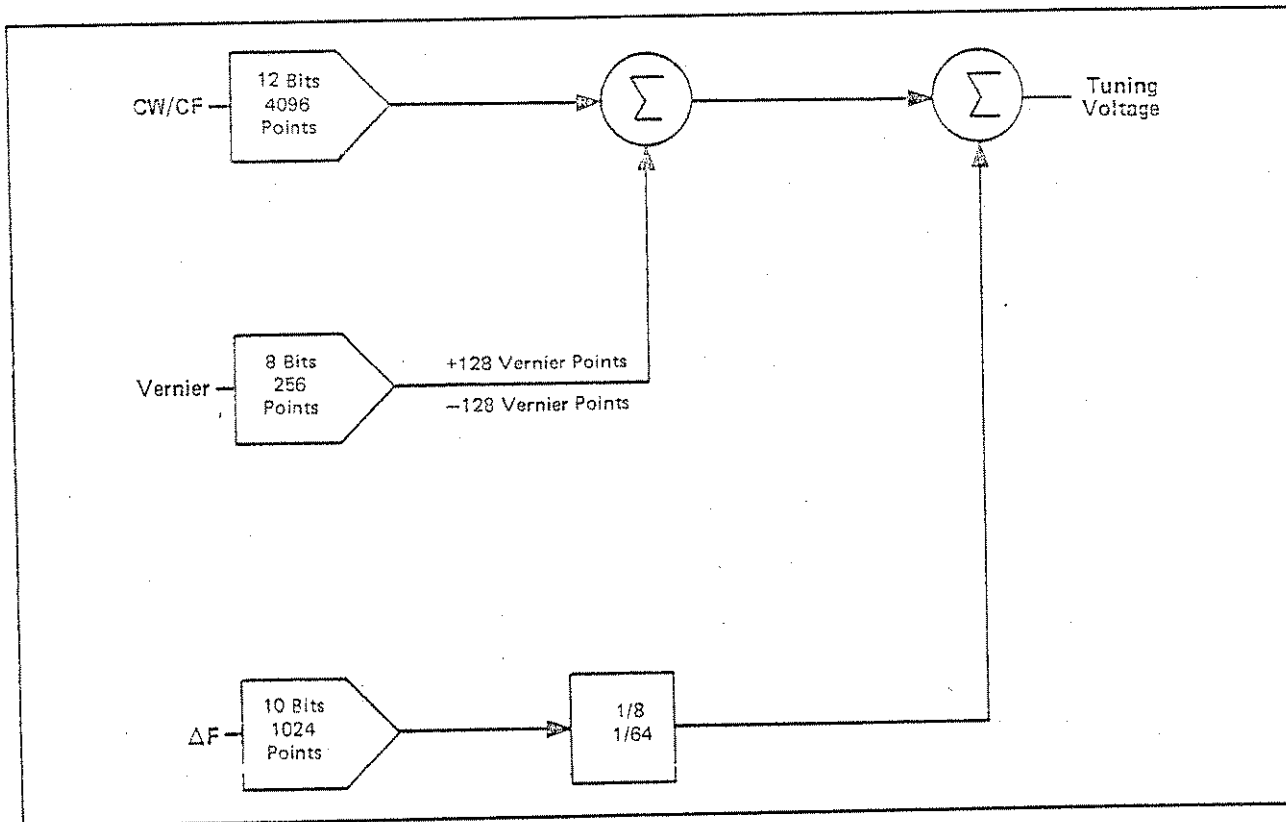

Figure 3-2. Simplified Tuning Voltage Block Diagram

	<u>ΔF Display Frequency Width</u>				
	0 MHz	124 MHz	1 GHz	4.2 GHz	20.0 GHz
<u>Displayed Resolution</u>	100 kHz	1 MHz	1 MHz	10 MHz	
<u>ΔF Display Indication</u>	000.0 MHz	0000. MHz	0000. MHz	00.00 GHz	

Figure 3-3. Delta F Sweep Mode Displayed Resolution

frequency and sweep width. The center frequency is specified by the center frequency (CF) DAC and the Vernier DAC, and the sweep width is determined by the ΔF DAC.

3-9. The CF DAC has 12 bits, hence 4096 points across any of the plug-in frequency bands (including overrange). The analog output ranges from zero to ten volts, which is used to coarsely specify the center frequency output of the plug-in. These parameters give the CF DAC a resolution of 0.024% (2.5mV) over the full band (including overrange).

3-10. Resolution of Center Frequency is enhanced by a summed voltage generated by an 8-bit (256 points) Vernier DAC. Vernier range is set to $\pm 0.05\%$ of bandwidth (including overrange). In multiband plug-ins, total range of the vernier will vary with each band sweep. Vernier resolution is determined by dividing $\pm 0.05\%$ bandwidth by 256 points (128 points either side of CF). The voltage range of the total 256 points on the Vernier DAC are equal to four points on the 12-bit CF DAC (two points on either side of CF). This increases CF resolution from 0.024% (2.5mV) to 0.00038% (.04mV), and improves the relative accuracy of the CF by a similar factor.

NOTE

When adjusting the vernier through its zero-point, the CF DAC is incremented or decremented by the total value of the vernier (2 points on the CF DAC). At this time the accuracy of the Center Frequency is again entirely dependent on the CF DAC, 0.005% of bandwidth.

3-11. The ΔF DAC has 10 bits (1024 points). The analog output from this DAC ranges from -5 to +5 volts to produce an even sweep on either side of the center frequency. The ΔF resolution improves with narrower sweep widths. For broad sweeps, the resolution is 0.1% of the full band. Greater resolution is provided for sweep widths less than 1/8 of the full band range. At these sweep widths, the resolution is improved to 0.012% of the full band.

3-12. Center Frequency is always displayed with 1 MHz resolution. Likewise, Vernier values are always displayed at 10 kHz resolution. Display resolutions for ΔF values vary with sweep width. Figure 3-3. illustrates the ΔF mode

displayed resolution values versus displayed ΔF frequency sweep widths.

3-13. PANEL FEATURES

3-14. Front and rear panel features are described in Figure 3-4 and 3-5, respectively. Numbered callouts on the features described match numbered descriptions below each figure.

3-15. OPERATORS CHECKS

3-16. The Operator's Checks portion (Local and Remote) of the 8350A Sweep Oscillator manual provides a quick evaluation of both 8350A and 83592A main functions. Error codes 50 to 99, displayed on the 8350A FREQUENCY display, are reserved to indicate plug-in related problems. The 8350A Local Check covers the sweep oscillator and RF plug-in. If the correct indications are not obtained, trouble may be in either of the units. If the RF plug-in is suspected, follow the troubleshooting information in Section VIII, Service, in this manual, to isolate the problem.

3-17. OPERATING INSTRUCTIONS

3-18. Front Panel FREQ CAL

NOTE

The 83592A RF Plug-in may not meet the frequency accuracy specifications unless the front panel FREQ CAL (frequency calibration) procedure is performed.

3-19. The front panel FREQ CAL procedure, shown in Figure 3-6, should be performed after the instrument has warmed up for at least one hour. This procedure calibrates the RF Output frequency for Band 0 with an external frequency counter.

3-20. Internal Leveling

3-21. The most convenient method of RF output leveling is internal leveling. A portion of the RF output is coupled out of an internal directional detector, producing a dc voltage proportional to the RF output signal. This detected dc voltage is applied to the automatic leveling control circuit (ALC).

3-22. External Crystal Detector Leveling

3-23. RF Output power may also be leveled externally using a power splitter (or external directional coupler) and a negative output crystal detector. This leveling system uses a power splitter to sample a portion of the RF Output signal with a crystal detector to produce a dc voltage proportional to the RF Output power level. The detector output voltage is compared with an internal reference voltage, and the difference voltage changes the output power level to keep a constant RF Output power level. A directional coupler may be used instead of a power splitter to sample the RF signal for the leveling loop. Directional couplers are usually narrow band devices, whereas the power splitter has a flatter frequency response over a wide frequency range. The advantage of a directional coupler is that it does not have as great a coupled loss as the 6 dB loss encountered with the power splitter, therefore, a higher maximum leveled power output may be obtained. Figure 3-7 illustrates a typical crystal detector leveling setup.

3-24. External Power Meter Leveling

3-25. RF Output power may also be leveled with a power meter and power splitter (or directional coupler) as shown in Figure 3-8. The sweep time is limited to greater than 100 seconds when this leveling method is used. A sample of the RF output signal is routed to a power meter which produces a dc output voltage proportional to the RF input signal level. This dc voltage is applied to the 83592A ALC circuits and compared with an internal reference voltage. A difference voltage is produced and amplified by the ALC amplifier before being applied, as modulator drive, to a PIN Modulator.

3-26. External FM

3-27. The 83592A RF output signal can be frequency modulated using an external modulating signal applied to the 8350A rear panel FM INPUT connector. The external FM function provides a means of obtaining an output frequency that varies under the control of an external modulating signal. A positive going voltage at the FM INPUT causes output frequency to decrease while a negative going voltage causes output frequency to increase. The sensitivity and coupling of the modulating signal may be set via configuration switch (A3S1). Figure 3-9 lists the available configuration switch settings. The configuration switch settings override 8350A Sweep Oscillator non-volatile memory settings at Instrument Preset.

3-28. External Amplitude Modulation

3-29. Pulse Modulation (PULSE IN Connector on Plug-in). The PULSE IN connector provides pulsed or square wave modulation, where the RF output is switched on and off. This input provides an on/off power ratio of greater than 30 dB below specified maximum leveled power. The PULSE IN input is normally at a TTL HIGH (approximately +3 volts dc). When a TTL LOW signal (approximately 0 volts dc) is applied, the RF output is turned off. To get the best pulse modulation performance, the RF output power should be set at +20 dBm. With this power setting, a pulse repetition rate of up to 1 MHz is achievable in the .01 to 7.0 GHz frequency bands. With leveled power in this frequency range, pulse repetition rates may be up to 100 kHz. In the 7.0 to 20.0 GHz frequency bands, RF power may be square--wave modulated at repetition rates up to 30 kHz at any power output setting. The input impedance for TTL level signals is approximately 500 ohms. If the PULSE IN circuit is driven beyond TTL levels, the input impedance is reduced to approximately 200 ohms due to the diode clamping action. See the specifications and supplemental characteristics in Section I for more details on the modulation characteristics when using this input.

3-30. Amplitude Modulation (AM INPUT Connector on 8350A).

The AM INPUT provides linear amplitude changes (up to approximately 15 dB) proportional to the modulating input voltage. It is limited to a frequency response of about 100 kHz. For maximum depth of modulation (i.e. maximum modulation index), the RF power level should be set to the middle of the control range (e.g. +2.5 dBm for a plug--in with calibrated power control from -5 to +10 dBm). For plug--ins equipped with Option 002 (70 dB step attenuator), the middle of the attenuator range should be selected. The center of the power control range may be selected with the front panel power control or by applying a dc bias voltage on the external modulating signal. A positive (+) dc voltage into the AM INPUT causes a decrease in RF output power; a negative (-) dc voltage causes an increase in RF output power.

3-31. RF Power Control

3-32. The RF power set at power-up (during Instrument Preset) may be either maximum power (+10 dBm) or RF power OFF as selected by the configuration switch (A3S1). Refer to Figure 3-9 for this setting. Configuration switch settings relating to the specific model plug-in used and Option 002 Step Attenuator equipped instruments must be set prior to operation. Configuration switch number 7 is set at the factory and should not be changed.

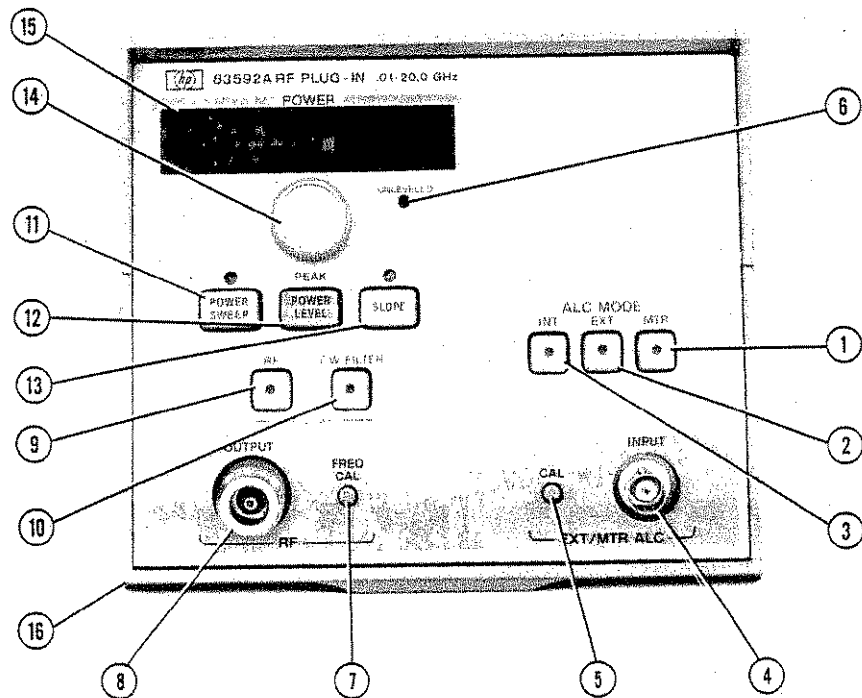

1. Power meter automatic leveling control selection (HP 432 only).
2. External (crystal detector) automatic leveling control selection (negative crystal output).
3. Internal leveling control selection.
4. Connector (BNC) for power meter or external crystal leveling inputs (rear panel on option 004).
5. Power level CAL adjust, for setting external (MTR or EXT) ALC.
6. UNLEVELED lamp lights if output power is unleveled.
7. Fine frequency adjust used for front panel frequency calibration.
8. Type--N 50--ohm RF output connector (rear panel on option 004, APC--7 connector for option 005).
9. RF on--off key. Used for zeroing a power meter or referencing an X--Y recorder.
10. CW FILTER enables an oscillator tune voltage filter when in CW mode.
11. POWER SWEEP allows setting an increase in power per sweep (dB/SWP).
12. POWER LEVEL allows setting of output power for all ALC modes (may be calibrated for external leveling). PEAK allows peaking of RF OUTPUT power (selected when (SHIFT) (POWER LEVEL) is pressed.)
13. SLOPE allows setting of the frequency slope compensation in dB/GHz (for lossy devices).
14. Power control knob for controlling power sweep, power level, peak, or slope.
15. Plug--in display provides readout of selected power mode in dBm, dB/GHz, or dB/SWP to a tenth of a dB/GHz.
16. Plug--in latch handle is used to remove, install, and latch the RF plug--in in the sweep oscillator.

Figure 3-4. Front Panel Features

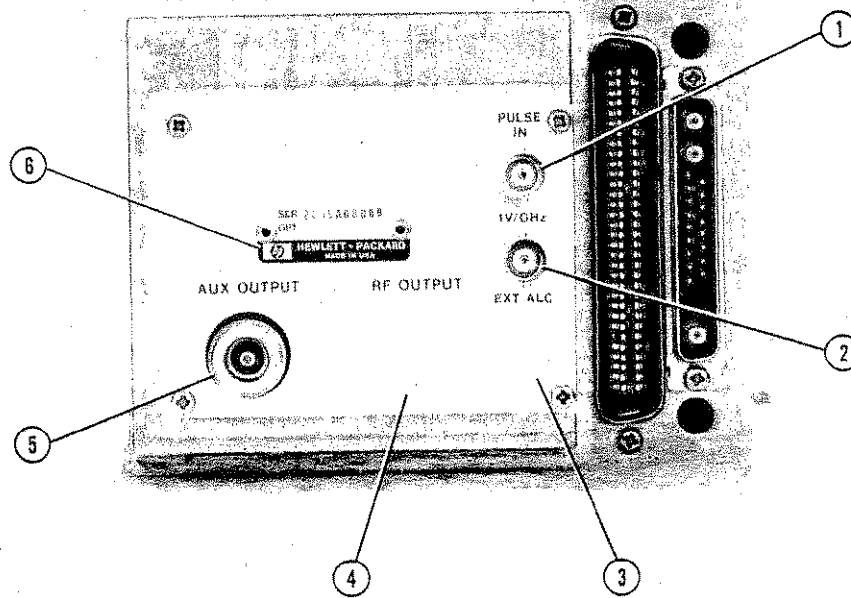

1. PULSE IN connector is used to input external pulse or squarewave modulation.
2. 1V/GHz connector provides a frequency reference output of approximately 1 volt dc per GHz.
3. EXT ALC connector replaces front panel EXT ALC connector on Option 004 plug--ins.
4. RF OUTPUT connector replaces front panel RF output connector in Option 004 plug--ins.
5. AUX OUTPUT connector provides 2.3 to 7.0 GHz fundamental oscillator output at approximately 0 dBm.
6. Serial Number Plate has a ten digit serial number (used in any correspondence concerning plug--in) and Option number if applicable.

Figure 3-5. Rear Panel Features

FREQ CAL Procedure

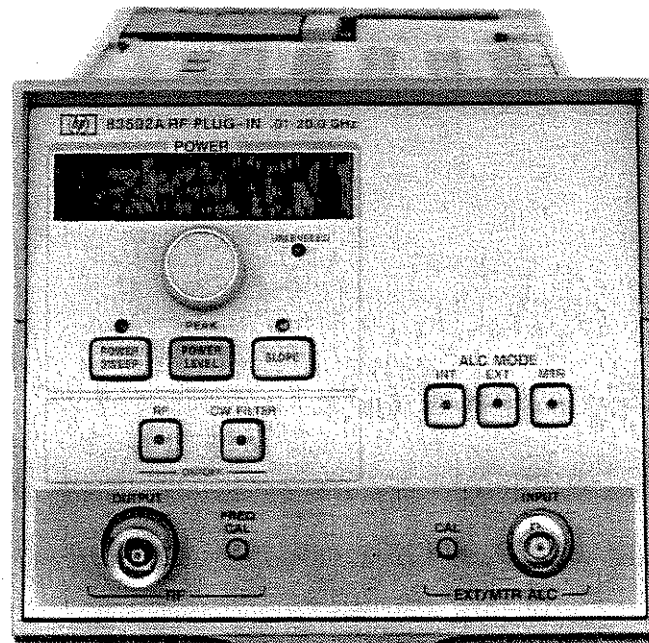

1. Press 8350A [INSTR PRESET] [CW] [5] [0] [MHz]
2. Connect external frequency counter through a 10 dB attenuator to the RF OUTPUT connector.
3. Adjust FREQ CAL control for a frequency counter indication of 50.0 MHz.

Alternate FREQ CAL Procedure

NOTE

This alternate FREQ CAL procedure is not as accurate as using an external counter, but normally calibrates the Band 0 frequency accuracy within specifications.

1. Press [INSTR PRESET] [CW] [0] [MHz].
2. Adjust FREQ CAL control through its range and note the portion of its range that the UNLEVELED light is turned on. Set the FREQ CAL control to the center of this range.

Figure 3-6. Front Panel FREQ CAL Procedure

EXTERNAL CRYSTAL DETECTOR LEVELING

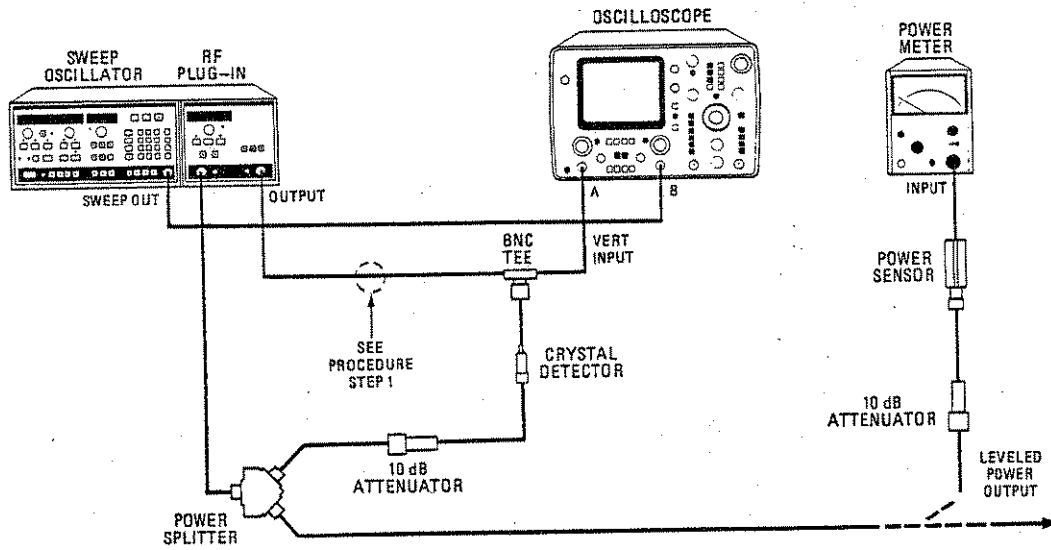

EQUIPMENT:

Sweep Oscillator	HP 8350A
RF Plug--in	HP 83592A
Oscilloscope	HP 1740A
Power Meter	435A
Power Sensor	HP 8485A
Crystal Detector	HP 8473C
Power Splitter	HP 11667A
10 dB Attenuator (2 required)	HP 8491B, Option 010
BNC Tee	HP 1250--0781

PROCEDURE:

NOTE

Crystal output signal must be between -10 mVdc and -200 mVdc.

1. Connect equipment as shown in test setup.

Figure 3-7. External Crystal Detector Leveling (1 of 2)

NOTE

Between 10 MHz and 50 MHz RF feedthrough as high as 3 dB may be observed on the envelope of the video output. During external leveling at 10 to 50 MHz, the RF feedthrough may be damped out by insertion of the circuit shown below in the test setup. The circuit may be inserted in the line to the EXT INPUT of the RF Plug--in.

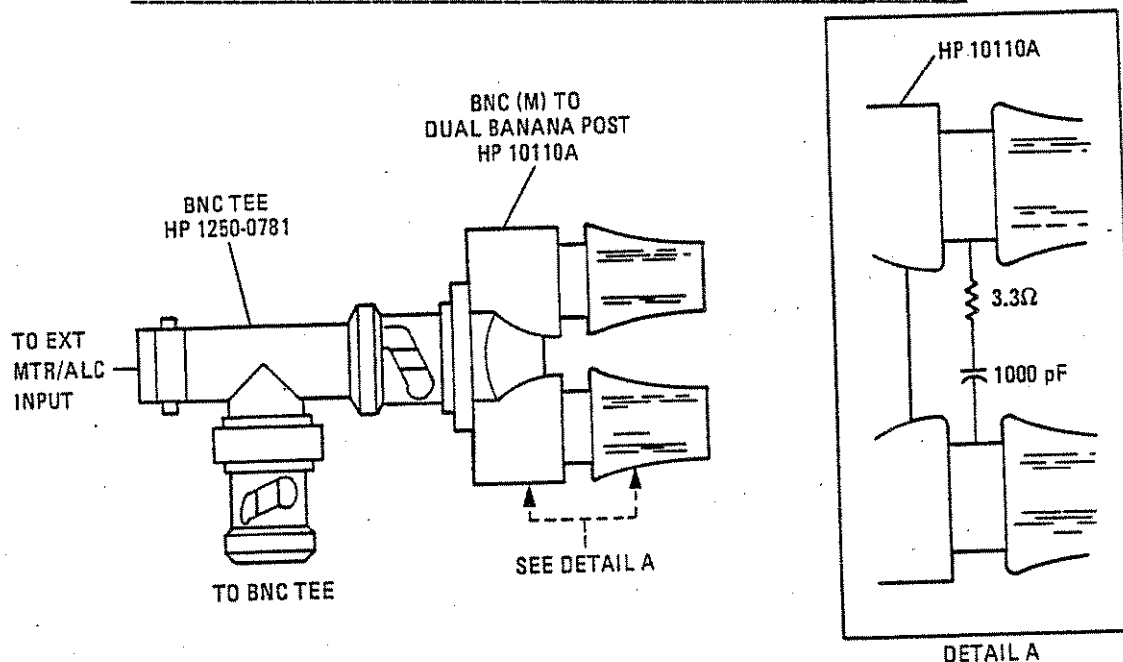

2. Switch on 8350A LINE switch. Press [INSTR PRESET] key. The START and STOP indicators should be on.
3. Set controls as follows:
 83592A:
 ALC MODE EXT
4. Adjust EXT/MTR ALC CAL for a power meter reading equal to the front panel output power.
5. To use leveled RF power output for testing external equipment, make connection at point marked "Level Power Output".

Figure 3-7. External Crystal Detector Leveling (2 of 2)

EXTERNAL POWER METER LEVELING

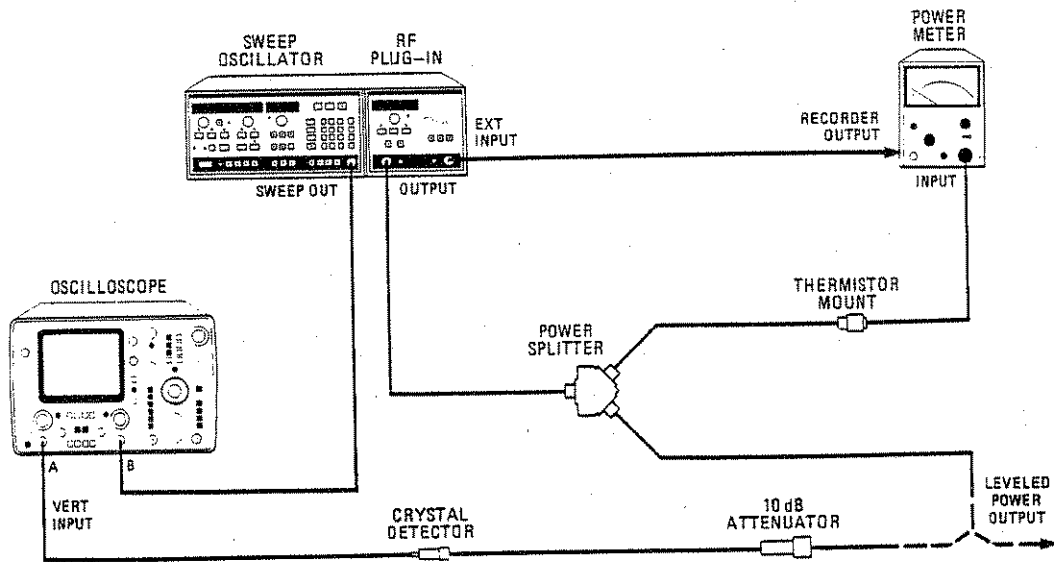

EQUIPMENT:

Sweep Oscillator	HP 8350A
RF Plug--in	HP 83592A
Power Meter	HP 432A
Thermistor Mount	HP 8478A
Oscilloscope	HP 1740A
Crystal Detector	HP 8473C
10 dB Attenuator	HP 8491B, Option 010
Power Splitter	HP 11667A

NOTE

For power meter leveling, sweep rates should be slower than 100 sec/sweep to ensure proper leveling due to the slow response of the thermistor mount. The HP 435 and 436 power meters will not power meter level this plug--in. Only an HP 432 may be used.

PROCEDURE:

1. Connect equipment as shown in test setup.
2. Set LINE switch to turn on sweep oscillator. The START and STOP indicators should light, indicating the START/STOP mode is

Figure 3-8. Power Meter Leveled (1 of 2)

selected.

3. Set controls as follows:

8350A: Press [INSTR PRESET]
SWEEP TIME 100 sec
START/STOP FREQUENCY As required (<18
GHz for 8478A Thermistor Mount)

83592A: Set power to maximum specified.
ALC MODE MTR

4. Select +10 dBm range on power meter.

5. Adjust 83592A EXT/MTR ALC CAL for a +7 dBm reading on the 432A power meter. Press 8350A SWEEP TRIGGER [SINGLE] key twice to set single sweep mode and start a sweep.

6. To use level RF power output for testing external equipment, make connection at point marked 'Levelled Power Output'.

3-33. Option 002 Step Attenuator

3-34. With Option 002 installed, the RF Output power may be continuously controlled from +10 dBm to -75 dBm. When the selected POWER setting goes below -5 dBm, the step attenuator increments as required in 10 dB steps to a maximum attenuation of 70 dB. Within the individual 10 dB steps of the attenuator, the ALC loop adjusts the power output to the power level programmed by the front panel POWER control.

3-35. Alternate Sweep Mode With Option 002

3-36. If Option 002 attenuator is installed, and alternate sweep mode is selected, a slow sweep default condition of 1 second/sweep may occur. This default condition only occurs when the POWER settings of the two alternate sweeps require the attenuator to switch after each sweep. The attenuator is prevented from switching faster than 1 step per second to prevent damage to the attenuator relay coils due to overheating.

3-37. Phase-Lock Operation

3-38. The 83592A RF plug-in RF Output (CW) signal may be phase-locked to an external reference oscillator by using an external phase-lock signal applied to the 8350A rear panel FM INPUT connector. The phase-lock function provides a means of obtaining a very stable CW frequency by transferring the frequency stability of the reference oscillator to the 8350A Sweep Oscillator. If the CW frequency starts to drift, the phase difference between the CW frequency and the reference frequency (reference oscillator) is detected, producing a dc voltage. The dc voltage is returned to the FM INPUT as a correction signal which restores the CW frequency to its previous point. Stability of the RF Output CW frequency is thus determined by the stability of the reference oscillator. The 83592A CW frequency used for phase-locking may be either the RF Output or the fundamental oscillator frequency available at the rear panel AUX OUTPUT. Configuration switch (A3S1) switch position B must be set for the source of the CW Frequency used for phase-locking (Figure 3-9). The CW filter should be turned off in phase lock operation.

3-39. OPERATOR'S MAINTENANCE

3-40. Plug-in Error Codes

3-41. The 8350A FREQUENCY window will display RF plug-in error codes (50 to 99) or sweep oscillator error codes.

Information necessary to interpret plug-in error codes may be found in Section VIII, Service, in this manual.

3-42. Fuses

3-43. Power circuits for the Model 83592A RF Plug-in are fused in the 8350A Sweep Oscillator. See the 8350A Sweep Oscillator Operating and Service Manual for fuse locations and replacement instructions.

3-44. Blue Service Tags

3-45. If the 83592A RF Plug-in requires service, the instrument may be sent to your local HP service organization as described in Section II, Installation, in this manual. Before sending the instrument back, fill out and attach one of the blue service tags. Record any error codes noted on the failure symptoms/special control settings portion of the tag.

U
S
E
R
S
E
R
V
I
C
E
M
A
N
U
A
L

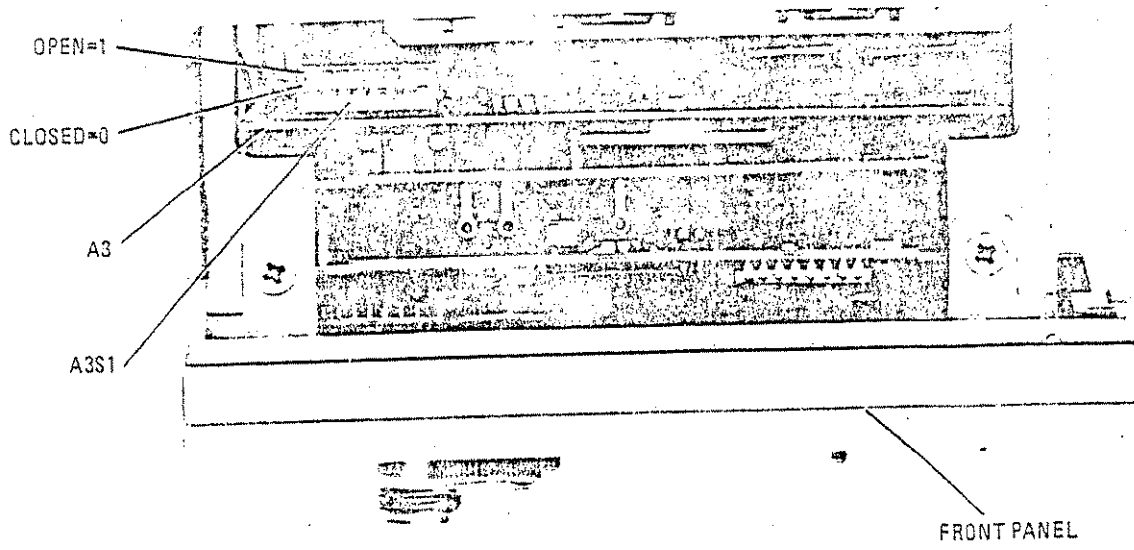

Description	Switch Number							
	1	2	3	4	5	6	7	8
Normal Sweep	0	X	X	X	X	X	X	X
Sequential Sweep Only	1	X	X	X	X	X	X	X
No RF Power at Instrument Preset	X	X	X	1	X	X	X	X
Maximum RF Power at Instrument Preset	X	X	X	0	X	X	X	X
-6 MHz/V FM Sensitivity	X	X	X	X	1	X	X	X
-20 MHz/V FM Sensitivity	X	X	X	X	0	X	X	X
Direct-Coupled FM (-20 MHz/V)	X	X	X	X	X	1	X	X
Cross-Over Coupled FM	X	X	X	X	X	0	X	X
Step Attenuator Option 002 Installed	X	X	X	X	X	X	1	X
No Step Attenuator	X	X	X	X	X	X	0	X
AUX OUT Phase Lock	X	X	X	X	X	X	X	1
RF OUTPUT Phase Lock	X	X	X	X	X	X	X	0

NOTES

- Switch Positions
 1= Switch Open= High
 0= Switch Closed= Low (Ground)
 X= Don't Care
 *= Varies, 1 if Opt. 002, 0 if no Opt. 002.

2. Switch is set at the factory as follows:

Switch No	1	2	3	4	5	6	7	8
Position	0	X	X	0	0	0	*	0

Figure 3-9. Configuration Switch

Vertical text on the right edge of the page, possibly a page number or header.

SECTION IV

PERFORMANCE TESTS

4--1. INTRODUCTION

4--2. The procedures in this section test the electrical performance of the 83592A RF Plug--in/8350A Sweep Oscillator combination with the specifications of the Plug--in used as the performance standards. Due to the extended frequency range of the 83592A, the performance tests in the 8350A Operating and Service manual do not apply. These specifications may be found in Section I of this manual. None of the tests require access to the interior of the 83592A RF Plug--in.

NOTE

Allow the 83592A RF Plug-in and 8350A Sweep Oscillator to warm up for one hour prior to doing any performance tests.

4--3. EQUIPMENT REQUIRED

4--4. Equipment required to test is listed in the Recommended Test Equipment table in Section I of this manual. Any equipment that satisfies the critical specifications given in the table may be substituted for the recommended model.

4--5. OPERATION VERIFICATION

4--6. Operation Verification consists of performing the tests listed on paragraph 4--13 steps 1 to 13 and paragraph 4--14 steps 1 to 14. Operation Verification of the HP--IB functions may be verified by executing the program listed in Section IV of the 8350A Operating and Service Manual. These tests provide reasonable assurance that the sweep oscillator and plug--in are functioning properly and should meet the needs of an incoming inspection (80% verification).

4--7. TEST RECORD

4--8. Table 4-15 provides a tabulated index of the performance tests, their acceptable limits, and a column for recording actual measurements.

4--9. TEST SEQUENCE

Thermister Mount	HP K486A
Crystal Detector	HP 8473C
Oscilloscope	HP 1740A

PROCEDURE:

1. Connect equipment as shown in Figure 4--2.
2. Press 8350A [INSTR PRESET], set SWEEP to MAN.
3. Set START, STOP frequencies and POWER LEVEL as noted for band 0 of Table 4--5.

POWER VARIATIONS AT MAXIMUM LEVELED POWER

4. Slowly tune the 8350A Frequency/Time control note the minimum power level in the band. Leave frequency at this low power point.
5. Adjust 83592A Power control for a power meter reading equal to the specified maximum leveled output power.
6. Slowly tune the 8350A Frequency/Time control through band. Note and record maximum power deviation on test record card.
7. Repeat steps 4 through 6 for the other band settings as per Table 4--5.

POWER LEVEL ACCURACY, RANGE and POWER SWEEP

8. Set START, STOP frequencies and POWER LEVEL as noted for band 0. Engage the 83592A [POWER SWEEP], set the dB/SWP level to 19dB/SWP. Disengage [POWER SWEEP] key.
9. Slowly tune the 8350A Frequency/Time control note the minimum and maximum power level in the band. Record these on the test card.
10. Press 83592A [POWER LEVEL] key. Use the 8350A [↕] key to step the power down 1 dB.
11. Repeat steps 9 and 10 for the specified level range as noted on Table 4--5.
12. Adjust the FREQUENCY/TIME control for highest frequency and note power meter level. Engage [POWER SWEEP] and record power meter level change on test record card.
13. Repeat steps 9 through 12 for the frequencies and power levels listed in Table 4--5.

5
 Table 4---~~5~~. Frequency and Power Settings

Band	START	STOP	POWER LEVEL	POWER SWEEP and LEVEL RANGE
0	0.05 GHz	2.40 GHz	+10 dBm	+10 - -5 dBm
1	2.40 GHz	7.0 GHz	+10 dBm	+10 - -5 dBm
2	7.0 GHz	13.5 GHz	+10 dBm	+10 - -5 dBm
A	13.5 GHz	18.6 GHz	+10 dBm	+10 - -5 dBm
3	13.5 GHz	20.0 GHz	+8 dBm	+8 - -5 dBm
B	0.01 GHz	18.6 GHz	+10 dBm	+10 - -5 dBm
Full	0.01 GHz	20.0 GHz	+8 dBm	+8 - -5 dBm

POWER METER LEVELING

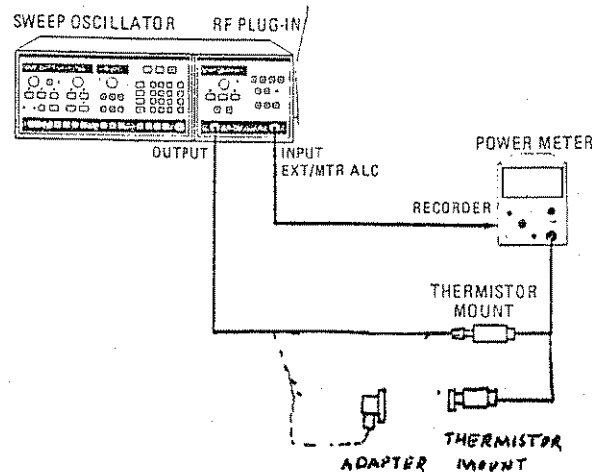

Figure 4--3. Power Meter Leveling Test Setup.

14. Connect equipment as shown in Figure 4--3 use HP 8485A Thermistor Mount.
15. Press 8350A [INSTR PRESET], set STOP frequency to 18 GHz. Set SWEPTIME to 100 sec. and SWEEP TRIGGER to [SINGLE].
15. Adjust ALC EXT/MTR CAL control and POWER METER range switch for correct power meter indication.
16. Press SWEEP TRIGGER [SINGLE] key and note power meter variations.
17. When SWP light goes out change to K486A Thermistor Mount and change START frequency to 18 GHz and STOP frequency to 20 GHz.
18. Press SWEEP TRIGGER [SINGLE] key and note power variations. The combined variations from step 16 and 17 should be ≤ 0.2 dB.

4-15. FREQUENCY STABILITY TEST

SPECIFICATION:

	Frequency (GHz)				
	0.01 to 2.4	2.4 to 7.0	7 to 13.5	13.5 to 20	0.01 to 20
With 10% Line Voltage Change	±50 kHz	±50 kHz	±100 kHz	±150 kHz	±150 kHz
With 10 dB Power Level Change	±200 kHz	±200 kHz	±400 kHz	±600 kHz	±600 kHz
With 3:1 Load SWR	±100 kHz	±100 kHz	±200 kHz	±300 kHz	±300 kHz
With Time (In a 10 minute period after one hour warmup)	<±100 kHz	<±100 kHz	<±200 kHz	<±300 kHz	<±300 kHz

DESCRIPTION:

A frequency counter is used to check frequency change due to line voltage changes, time (10 minutes), output power level changes, and load impedance changes.

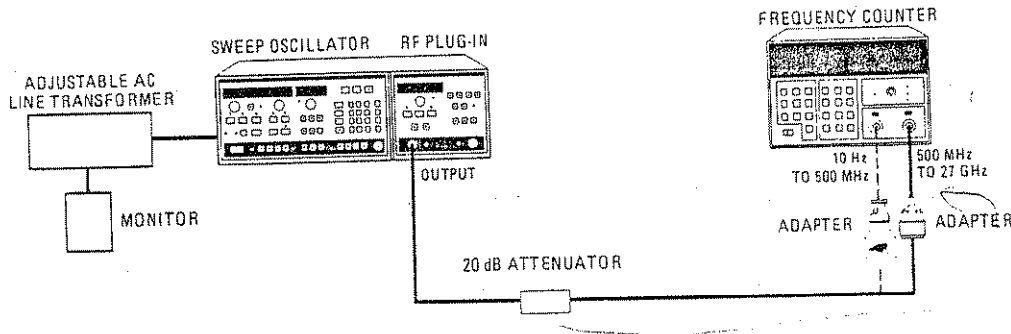

Figure 4-5. Frequency Change with Line Voltage Change

EQUIPMENT:

NOTE

More than one model number is listed for some test equipment. Use only the equipment needed to cover the line voltage used.

Sweep Oscillator	HP 8350A
Frequency Counter	HP 5343A
20 dB Attenuator	HP 8491B Option 020
	Weinschel Model 9-20

Adapter Type--N, male to APC 3.5,
female

Directional Coupler HP 778D
Directional Coupler HP 11692D

Adjustable AC Line Transformer and monitor
(Select for line voltage needed)
100--120 volt General Radio W5MTB
120 V Monitor RCA WV 120B
220--240 volt General Radio W10HM73
240V Monitor RCA WV 503A
3 dB Attenuator HP 8491B Opt. 003
Adjustable Short Maury Microwave
1953-2

PROCEDURE:

Frequency Change with Line Voltage Change

1. Connect equipment as shown in Figure 4--5 and set 8350A LINE switch to ON.
2. Set adjustable line transformer using suitable monitor to the line voltage set on the 8350A power module. Press the 8350A [INSTR PRESET] and [CW] key and enter the 8350A frequency shown below (Frequency Stability). Rotate frequency counter SAMPLE RATE knob to HOLD, press [SET], [OFS MHZ], [Blue Key], then rotate the Frequency Counter SAMPLE RATE knob counter--clockwise back to the normal position.

Table 4-~~5~~⁶. High and Low Line Voltage Selection Table

Nominal Line Voltage	100V	115/120V	220V	240V
Low Line Voltage	90V	108V	198V	216V
High Line Voltage	105V	126V	231V	252V

3. Set adjustable line transformer to the low line voltage using suitable monitor which corresponds to the selected nominal voltage in Table 4-~~5~~⁶. Check and record on the test card step 3 the difference frequency displayed on counter.

- Set adjustable line transformer using suitable monitor to the high line voltage using suitable monitor which corresponds to the selected nominal voltage. Check and record on the test record card step 4 the difference frequency displayed on counter.

Table 4-~~7~~⁷. Frequency Change with Line Voltage Change.

Band	CW Frequency	Frequency Change
Band 0	1.0 GHz	± 50 kHz
Band 1	6.0 GHz	± 50 kHz
Band 2	12.0 GHz	± 100 kHz
Band 3	18 GHz	± 150 kHz

Frequency Change with Time (10 minutes)

- Set adjustable line transformer voltage to nominal. Enter [POWER LEVEL] [1] [0] [dBm], then [CW] [1] [GHz] (wait one minute for frequency counter and oscillator to settle).
- Rotate the frequency counter SAMPLE RATE knob to HOLD, press [SET], [OFS MHZ], [Blue Key], then rotate the Frequency Counter SAMPLE RATE knob counter--clockwise back to the normal position. The counter is now indicating frequency change with time.
- Wait 10 minutes while observing frequency count for maximum frequency change and record this maximum change on the performance test record card step 7.
- Repeat steps 6 and 7 for the other frequencies shown in Table 4-~~7~~⁸.

Table 4-~~7~~⁸. Frequency Change with Time.

Band	CW Frequency	Frequency Change
Band 0	1.0 GHz	± 100 kHz
Band 1	6.0 GHz	± 100 kHz
Band 2	12.0 GHz	± 200 kHz
Band 3	18 GHz	± 300 kHz

Frequency Change with 10 dB Power Level Change

9. Enter [CW] [1] [GHz].
10. Rotate the frequency counter SAMPLE RATE knob to HOLD, press [SET], [OFFSET], [Blue Key], then rotate the frequency counter SAMPLE RATE knob counter--clockwise back to the normal position. Enter [POWER LEVEL] [0] [dBm]. Verify the frequency change is less than given in Table 4-~~xx~~⁹.
11. Repeat step 9 for the other frequencies given in Table 4-~~xx~~⁹.

Table 4-~~xx~~⁹. Frequency Change with Power Level Change

Band	CW Frequency	Frequency Change
Band 0	1.0 GHz	+200 kHz
Band 1	6.0 GHz	+200 kHz
Band 2	12.0 GHz	+400 kHz
Band 3	18 GHz	+600 kHz

Frequency Change With 3:1 Load SWR

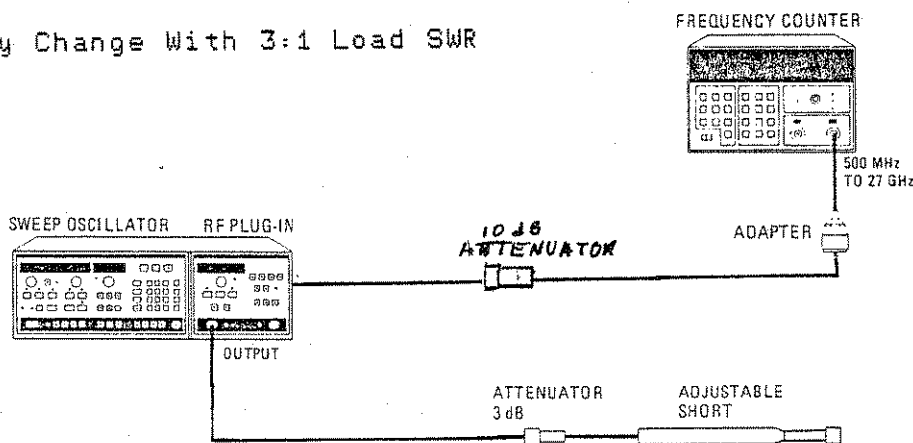

Figure 4-6. Frequency Change with 3:1 Load SWR Test Setup

12. Connect equipment as shown in Figure 4-6. Press the 8350A [INSTR PRESET], [CW] [1] [GHz], then [POWER LEVEL] [1] [0] [dBm].
13. Since the frequency of the AUX OUTPUT is being counted, a

multiplication factor must be entered for bands 2 and 3 only to yield actual RF OUTPUT frequency errors. No factor is needed for bands 0 and 1. In band 2 press [SET], [.], [2], and [ENTER] on counter. In band 3, press [SET], [.], [3], and [ENTER]. Note that in band 0, the counter will not read the desired output frequency. This is because the AUX OUTPUT frequency is mixed down to yield the front panel frequency.

13. On counter rotate the SAMPLE RATE knob clockwise to HOLD, press [SET], [OFS MHZ], [Blue Key], then rotate the SAMPLE RATE knob counter--clockwise to the normal position on the Frequency Counter.
14. Adjust the adjustable short through its range while observing the frequency counter for the greatest plus and minus frequency change. Check that the peak--to--peak frequency change is less than given in Table 4--~~xx~~.
10
15. Enter the next CW frequency and repeat steps 13 and 14. To clear the counter multiplication factor, press [SET], [.], and [ENTER].

Table 4-10. Frequency Change with 3:1 Load SWR.

Band	CW Frequency	Frequency Change
Band 0	1.0 GHz	± 100 kHz
Band 1	6.0 GHz	± 100 kHz
Band 2	12.0 GHz	± 200 kHz
Band 3	18 GHz	± 300 kHz

4--16. RESIDUAL FM TEST

SPECIFICATION:

10 kHz Bandwidth, CW MODE with CW Filter

0.01 to 7 GHz < 8 kHz

7 to 20 GHz < 15 kHz

DESCRIPTION:

The CW RF output signal is slope detected by using the linear portion of a spectrum analyzer resolution bandwidth filter in the zero-span mode. The residual FM of the signal is represented by the filtered auxiliary vertical output voltage from the spectrum analyzer measured by an rms responding voltmeter.

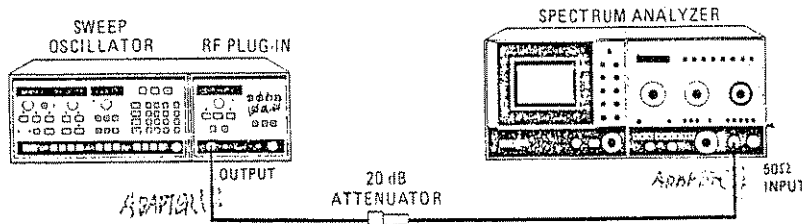

Figure 4--7. Residual FM Test Setup

EQUIPMENT:

Sweep Oscillator	HP 8350A
Spectrum Analyzer	HP 8565A
RMS Voltmeter	HP 3400A

PROCEDURE:

1. Connect equipment as shown in Figure 4--7, but do not connect the RF OUTPUT at this point.
2. Press 8350A [INSTR PRESET],[CW]. Enter a CW frequency of 1.0 GHz

NOTE

To minimize drift, allow five minutes warmup before continuing with test.

3. Set spectrum analyzer controls as follows:

TUNING	0.0 MHz
FREQ SPAN/DIV	.5 MHz
RESOLUTION BW	300 kHz (uncoupled)
OPTIMUM INPUT	-10 dBm (30 dB atten)
REFERENCE LEVEL dBm	+10 dBm
10 dB/DIV-1 dB/DIV/LIN	10dB/DIV
TIME/DIV	1 msec/DIV
TRIGGER	FREE RUN
BASELINE CLIPPER	fully counterclockwise
(OFF)	
VIDEO FILTER	.03

4. Adjust spectrum analyzer TUNING to center the L.O. feedthrough signal on the spectrum analyzer display.
5. Adjust spectrum analyzer REFERENCE LEVEL controls to place the peak of the signal trace at the reference level (top) graticule line if possible.
6. Change the display scale to 1 dB/DIV and repeat step 5 if necessary.
7. Reduce FREQ SPAN/DIV to 5 kHz while keeping the signal centered with the TUNING control.
8. Decrease REFERENCE LEVEL by 10 dB and place trace at mid--screen by turning the TUNING control counterclockwise. A positive--slope ramp (a portion of the 300 kHz bandwidth filter trace) should now be centered on the display (see Figure 4--**).
9. Measure the filtered vertical output voltage from the spectrum analyzer with the RMS voltmeter (it should be approximately 60 to 70 mV). Record this voltage:-----mV rms.

NOTE

The spectrum analyzer's vertical output in step 8 is a 100 Hz (1 msec/DIV sweep) sawtooth wave whose amplitude corresponds to a frequency modulation of 50 kHz peak--to--peak, or 14.4 kHz

ms.

10. Connect the RF OUTPUT signal to the spectrum analyzer.

11. Set spectrum analyzer controls as follows:

TUNING	1.00 GHz
FREQ SPAN/DIV	1 MHz
10 dB/DIV-1 dB/DIV-LIN	10 dB/DIV
REFERENCE LEVEL dBm	+10 dBm

12. Adjust spectrum analyzer REFERENCE LEVEL controls to place the peak of the signal trace at the reference level (top) graticule line.
13. Set spectrum analyzer display scale to 1 dB/DIV and repeat step 12 if necessary.
14. Reduce FREQ SPAN/DIV to 0 while keeping the signal centered on the CRT with the TUNING control.
15. Decrease REFERENCE LEVEL by 10 dB and position trace at midscreen by turning TUNING control counterclockwise.
16. Measure the filtered vertical output voltage from the spectrum analyzer with the RMS voltmeter to obtain the residual FM voltage. Calculate residual FM as follows:

$$\text{Residual FM (kHz)} = \frac{\text{residual FM voltage (mV rms)}}{\text{voltage from step 8 (mV rms)}} \times \frac{50}{\cancel{100}} \text{ kHz}$$

$$= \text{-----kHz}$$

17. Verify that residual FM is within tolerance given in Table 4--xx.
18. Repeat steps 10 through 17 with spectrum analyzer and RF Plug--in tuned to each frequency listed in Table 4--xx.

Table 4--~~xx~~. Residual FM

Band	CW Frequency	Residual FM
Band 0	1.0 GHz	< 8 kHz
Band 1	6.0 GHz	< 8 kHz
Band 2	12.0 GHz	< 15 kHz
Band 3	18 GHz	< 15 kHz

4--17. SPURIOUS SIGNALS TEST

SPECIFICATION:

Spurious Signals at specified maximum leveled power	Frequency (GHz)				
	.01-2.4	2.4-7	7-13.5	13.5-20	0.01-20
Harmonics (in dB below carrier)	>25 dB	>25 dB	>25dB	>25 dB	>25 dB
Non-Harmonics	>25 dB	>50 dB	>50 dB	>50 dB	>25 dB

DESCRIPTION:

RF output signal from sweep oscillator is displayed on a spectrum analyzer to verify that harmonic and non-harmonic spurious signals are at or below the specified level.

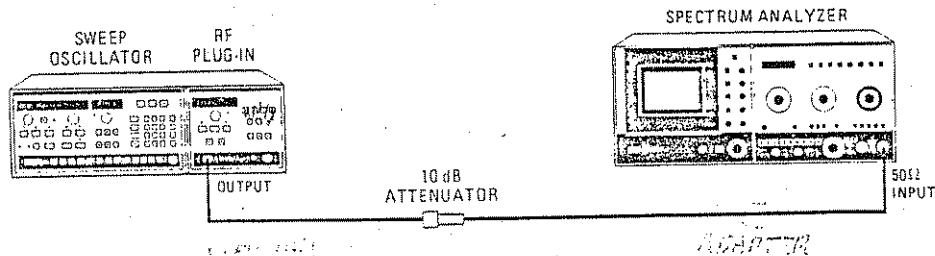

Figure 4--9. Spurious Signals Test Setup

EQUIPMENT:

Sweep Oscillator	HP 8350A
Spectrum Analyzer	HP 8565A
10 dB Attenuator	Weinschel Model 9-10

PROCEDURE:

1. Connect equipment as shown in Figure 4--9.
2. Set controls as follows:

8565A:

Set all Normal Settings (controls marked with green)

FREQUENCY BAND GHz	.01-1.8
INPUT ATTN	10 dB
REF LEVEL dBm	+10 dBm
FREQUENCY SPAN MODE	FULL BAND

8350A

Press [INSTR PRESET],[CW], [1] [0] [MHz].

83592A

POWER +10 dBm
CW FILTER ON

NOTE

The spectrum analyzer originates some mixing products that may appear on the display. If a signal is in question, increase the spectrum analyzer input attenuation by 10 dB, note if signal decreases in amplitude by 10 dB, then return the attenuator to the original position. If the signal in question comes from an external source, it will change by 10 dB. If the signal in question originates in the spectrum analyzer, the level will either change by greater or less than 10 dB or may not change at all.

The 8350A CW control when being rotated may generate some noise spikes. These signals should disappear when rotation is stopped.

If a spurious signal is found that appears out of specifications check the fundamental signal amplitude to ensure it is at maximum specified power. Then check spurious level by substituting a known amplitude signal on the spectrum analyzer.

3. Adjust the 8350A CW control through the entire frequency range of the RF plug-in (.01 to 20.0 GHz) and check for harmonic and non-harmonic spurious signals. The specifications for harmonic and non-harmonic signals are listed below.
4. Change the spectrum analyzer to each of the next higher frequency bands and repeat the previous step.

Frequency Band (83592A)	Harmonics db below carrier	Nonharmonics dB below carrier
0.01 to 2.4 GHz	>25 dB	>25 dB
2.4 to 7.0 GHz	>25 dB	>50 dB
7.0 to 13.5 GHz	>25 dB	>50 dB
13.5 to 20 GHz	>25 dB	>50 dB

4--18. OUTPUT VSWR TEST

SPECIFICATION:

Output SWR: ~~1.9~~ 2.1

DESCRIPTION:

The RF Output signal is measured using a directional coupler, crystal detector, and oscilloscope. The signal at the oscilloscope contains (1) the incident signal from the oscillator, and (2) the reflected signal. The reflected signal is developed as follows: The incident signal travels down the 20 cm air lines (2 to 18 GHz) or 3 to 6 metres of coaxial cable (.01 to 2 GHz), encounters the open end, and is reflected back to the source. If the reflected signal at the RF OUTPUT connector encounters a perfect 50--ohm source match, no signal is reflected back. However, the greater the mismatch, the greater the reflected signal. This reflected signal either adds to or subtracts from the incident signal. This variation is displayed on the oscilloscope.

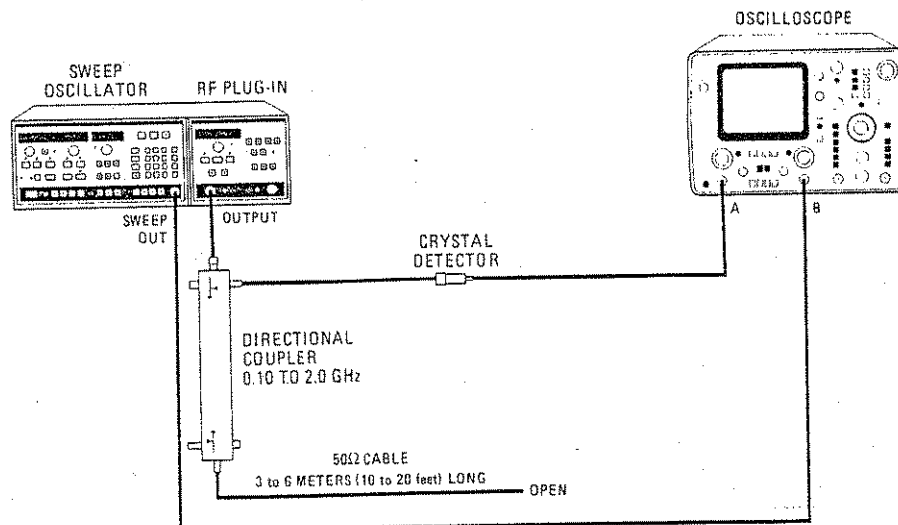

Figure 4--10. Low Frequency Output VSWR Test Setup

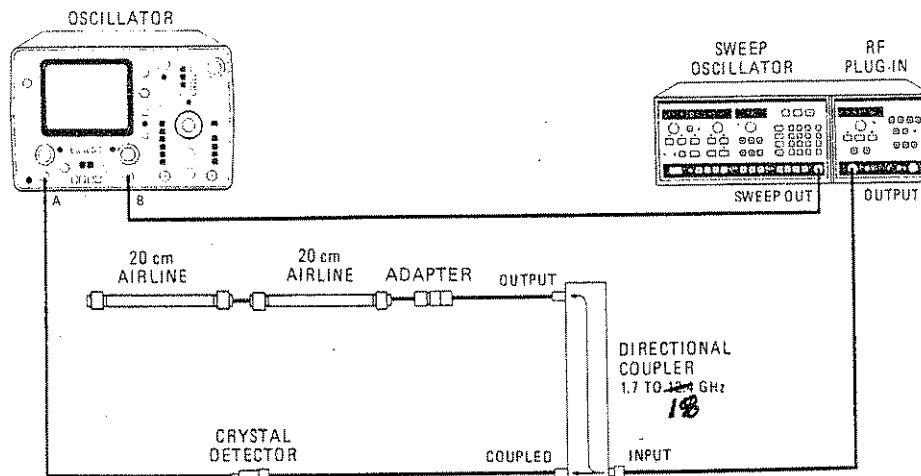

Figure 4--11. High Frequency Output VSWR Test Setup

EQUIPMENT:

Sweep Oscillator	HP 8350A
Oscilloscope	Any general purpose oscilloscope such as HP 1222A or 1740A
Crystal Detector	423B
Directional couplers	
0.10 to 2 GHz	HP 778D
1.7 to 18 GHz	HP 11692D
Cable	
0.01 to 2 GHz	3 to 6 metres (10 to 20 feet) see Table 4--3
2 to 18	HP 11567A 20--cm Air Lines (2 required)
Adapter APC-7 to Type-N male	HP 11525AC

PROCEDURE:

Low Frequency Output VSWR Test

NOTE

A single section of 3 to 6 metre (10 to 20 feet) 50--ohm cable is required to avoid mismatch of connector when performing the low frequency VSWR test.

1. Connect equipment as shown in Figure 4--10.
2. Press [INSTR PRESET], [STOP], [2], [GHZ/s] on 8350A. Set DISPL BLANKING off and RF BLANKING on.
3. Adjust POWER level control on plug--in for an maximum output power of -25 millivolts peak trace on oscilloscope display in order to keep crystal in square law output range.

- Select several points on trace and calculate V_{MAX}/V_{MIN} (see Figure 4--12).

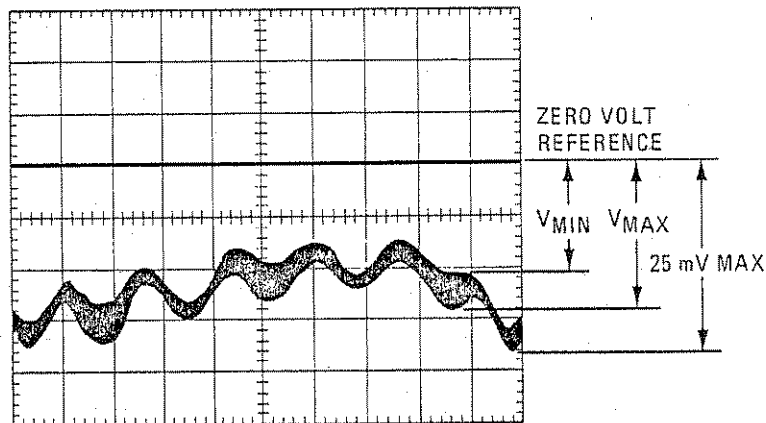

Figure 4--12. Typical Low Frequency Swept VSWR Measurement

- Determine the loss at selected frequency of the length of coaxial cable (between coupler end and cable open end), using manufacturer's specifications for loss/foot. (Refer to Table 4--4.)
- Convert V_{MAX}/V_{MIN} ratio noted in step 5 into source match SWR, using Figure 4--13 and the cable loss calculated in step 5. The SWR should be less than 1.9.

High Frequency Output VSWR Test

- Connect equipment as shown in Figure 4--11.
- Press [INSTR PRESET], [START], [2], [GHz], [STOP] [1] [8] [GHz] on 8350A. Set DISPL BLANKING off and RF BLANKING on.
- Adjust POWER control on plug--in for a maximum output power of -25 millivolts peak trace on oscilloscope display in order to keep crystal in square law output range.
- Select points on trace where V_{MAX}/V_{MIN} appear to have greatest separation and calculate V_{MAX}/V_{MIN} for each point.
- Convert greatest V_{MAX}/V_{MIN} ratio noted in step 10 into source match SWR using Figure 4--13 on the 0 dB loss line. The SWR should be less than 1.9.

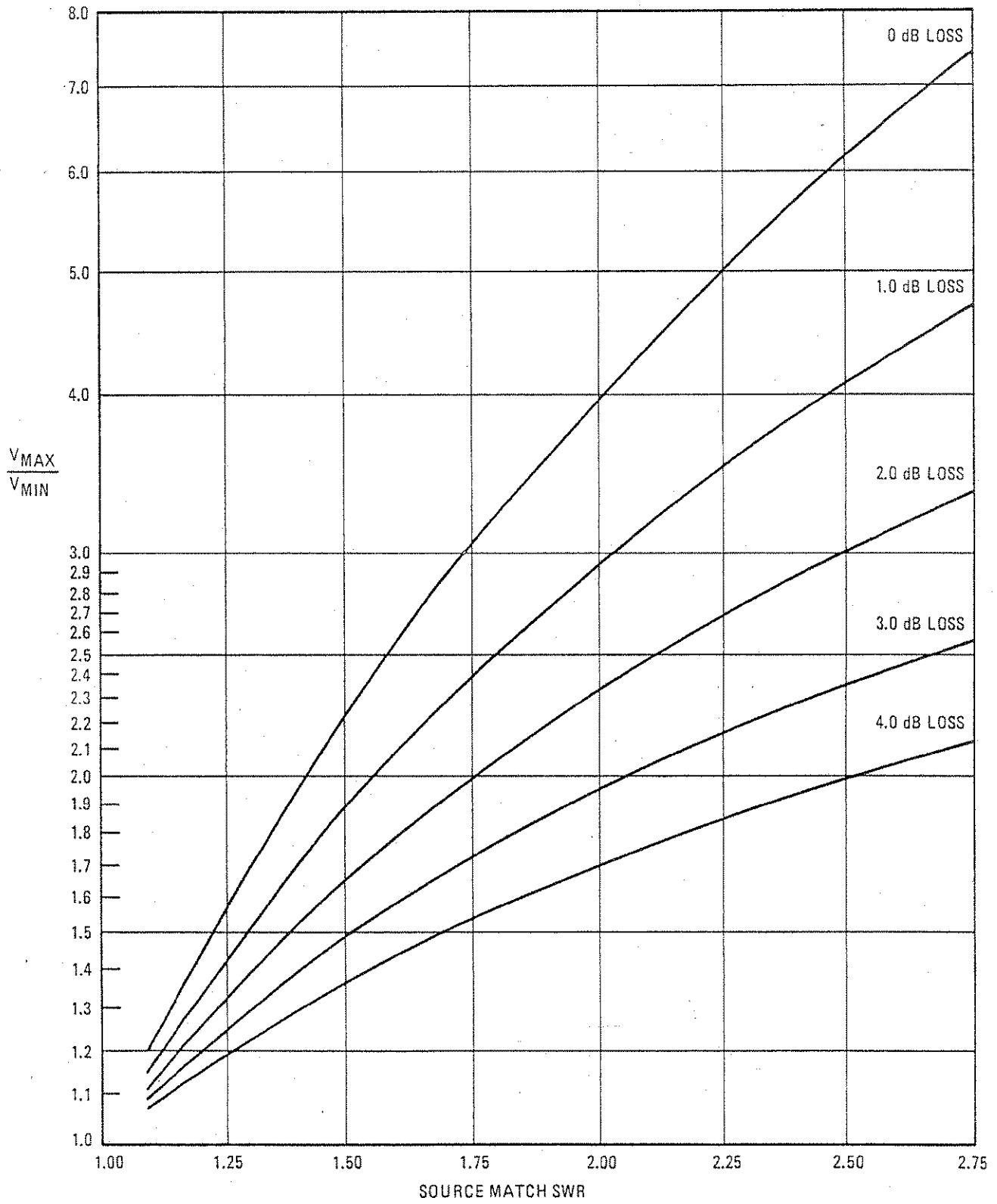

Figure 4-13. Conversion of Oscilloscope Trace to Source Match SWR

Table 4--¹³ Loss in Coaxial Cable

RG Cable Type	Attenuation (dB/100 ft.) at Selected Frequency					
	0.1 GHz	0.2 GHz	0.4 GHz	0.6 GHz	1 GHz	3 GHz
58/U	2.4	3.6	5.2	6.6	8.8	16.7
98/U	2.3	3.4	5.2	6.5	9.0	17.0
55A/U	4.8	7.0	10.5	13.0	17.0	32.0
58A/U	6.2	9.2	14.0	17.5	23.5	45.0
58C/U	6.2	9.2	14.0	17.5	23.5	45.0
177/U	0.95	1.5	2.4	3.2	4.5	9.5
212/U	2.4	3.6	5.2	6.6	8.8	16.7
213/U	2.1	3.1	5.0	6.5	8.8	17.5
214/U	2.3	3.4	5.2	6.5	9.0	17.0
215/U	2.1	3.1	5.0	6.5	8.8	16.7
217/U	1.5	2.3	3.5	4.4	6.0	11.7
218/U	0.95	1.5	2.4	3.2	4.5	9.5
219/U	0.95	1.5	2.4	3.2	4.5	9.5
220/U	0.69	1.12	1.85	—	3.6	7.7
221/U	0.69	1.12	1.85	—	3.6	7.7
223/U	4.8	7.0	10.5	13.0	17.0	32.0
224/U	1.5	2.3	3.5	4.4	6.0	11.7

4--19. RESIDUAL AM

SPECIFICATION:

Residual AM in 100 kHz Bandwidth ≥ 50 dB
(in dB below carrier and at
specified maximum leveled power)

DESCRIPTION:

The RF Output signal from the RF Plug--in is amplitude modulated with a square wave from the 8350A. This modulated signal is used to establish a reference on the RMS voltmeter that is 9 dB below actual carrier signal. The 9 dB reduction occurs because of voltmeter response to square wave and square--law response of crystal detector. Modulation is then removed and the magnitude of the Residual AM component is measured with respect to established reference.

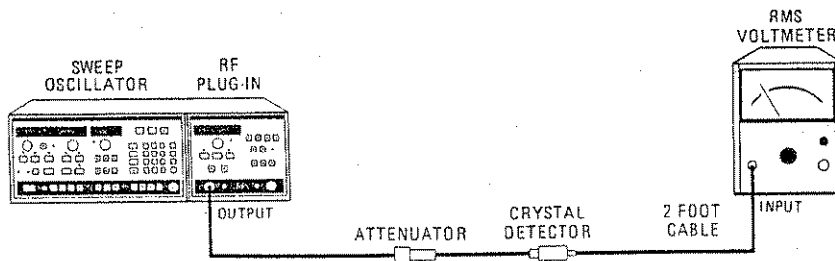

Figure 4--14. Residual AM Test Setup

EQUIPMENT:

Sweep Oscillator	HP 8350A
RMS Voltmeter	HP 3400A
Crystal Detector	HP 8473C
Attenuator	Refer to PROCEDURE
60 cm (24 in) cable (Limits bandwidth to approximately 100 kHz)	HP11170B

PROCEDURE:

1. Connect equipment as shown in Figure 4--14 using a 20 dB attenuator.
2. Press [INSTR PRESET], [CW], engage [## MOD] (1 kHz or 27.8 kHz), disengage [DISPL BLANK].

NOTE

A 41 dB decrease in the RMS voltmeter indication corresponds to a 50--dB reduction in signal level. A correction factor of 9 dB is added because of the RMS voltmeter response to a square wave and the square--law response of the crystal detector.

3. Set POWER LEVEL to +10 dBm and CW frequency to 1 GHz.
4. Vary attenuation using 3 dB, 6 dB, and 10 dB attenuators until reading on RMS voltmeter is -28 dB \pm 3 dB. Note voltmeter reading.
5. Disengage [##MOD]. Change RMS voltmeter range switch to obtain an on-scale indication. Calculate the difference between this reading and the indication noted in step 4. Add 9 dB to compensate for square--law inequities, and verify meets the tolerance in Table 4--~~14~~.
14
6. Engage [##MOD]. Repeat steps 4 and 5 for frequencies given in Table 4--~~14~~.
14

Table 4-14. Residual AM

Band	CW Frequency	Residual AM (dB below carrier)
Band 0	1.0 GHz	>50 dB
Band 1	6.0 GHz	>50 dB
Band 2	12.0 GHz	>50 dB
Band 3	18 GHz	>50 dB

4--20. EXTERNAL FREQUENCY MODULATION TEST

SPECIFICATION:

DC to 100 Hz:

Cross Over Coupled

±75 MHz

Direct Coupled

±12 MHz

100 Hz to 1 MHz:

± 7 MHz

±7 MHz

1 MHz to 2 MHz:

± 5 MHz

±5 MHz

2 MHz to 10 MHz:

±1 MHz

±1 MHz

DESCRIPTION:

The RF Output is modulated with an external signal at 100 Hz, 1 MHz, 2 MHz and 10 MHz. The 100 Hz deviation is measured directly on a spectrum analyzer. The deviation at the higher frequencies is found by using a delay line discriminator to observe an increase in the modulation on an oscilloscope until distortion is observed. This frequency change is measured on a frequency counter.

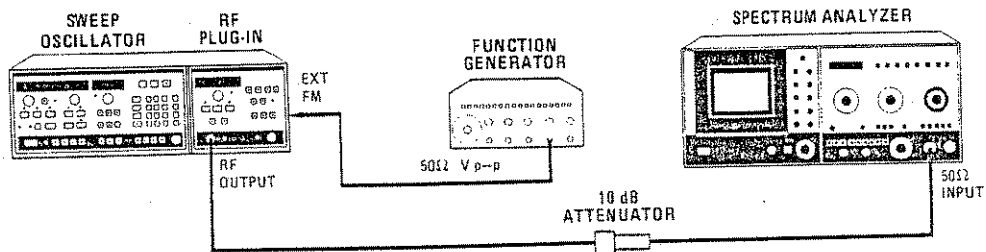

Figure 4--15. 100 Hz External Frequency Modulation Test Setup

EQUIPMENT:

Sweep Oscillator	HP 8350A
Spectrum Analyzer	HP 8565A
Frequency Counter	HP 5343A
Function Generator	HP 3312A
Oscilloscope	Any general purpose
oscilloscope such as HP 1222A* or 1740A	

10 dB Attenuator Weinschel Model 9-10
 Power Splitter Weinschel Model 1579A
 Delay Line Discriminator (See Figure 1--3)
 * Add a 50 Ω load and BNC Tee to each oscilloscope input.

PROCEDURE:

100 Hz Modulation

1. Ensure that modulation sensitivity is set to -20 MHz/volt and modulation coupling to DC (see Figure 4-xx). Connect equipment as shown in Figure 4--15.
2. Press 8350A [INSTR PRESET], [CW] and disengage the [DISPL BLANK] key. Disengage RF plug--in [CW FILTER] key. Center fundamental signal on spectrum analyzer CRT display. Set function generator frequency to 100 Hz sinewave and amplitude to full counterclockwise. Adjust function generator amplitude control slowly clockwise while monitoring display on spectrum analyzer. Deviation from center line should be symmetrical at first then become non--symmetrical as deviation increases.
3. Note point at which deviation becomes non--symmetrical and verify that it is greater than ± 12 MHz.
4. Turn 8350A LINE switch to off. Remove RF plug--in and switch modulation coupling to crossover (see Figure 4--xx). Install the RF plug--in and turn the 8350A line switch to on. Then repeat steps 2 and 3. The highest symmetrical deviation frequency should be greater than ± 75 MHz.

>100 Hz FM Modulation

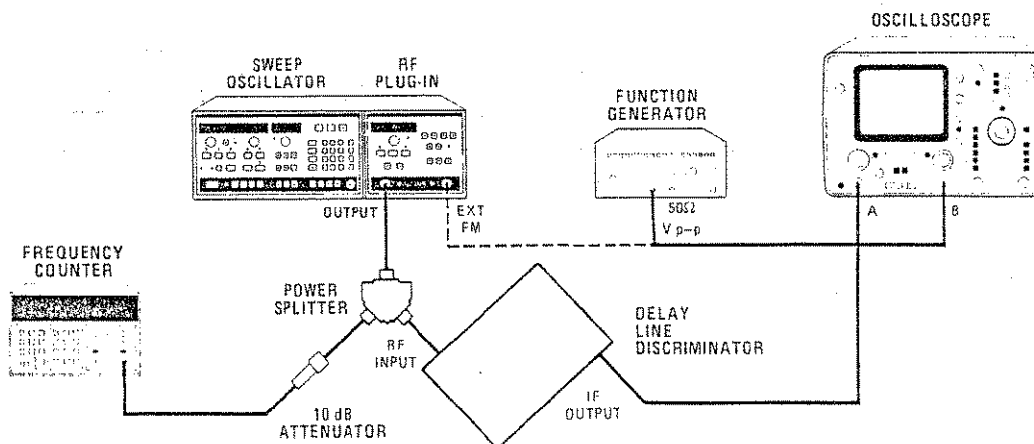

Figure 4-16 ≥ 100 Hz Frequency Modulation Test Setup

5. Set function generator frequency to 1 MHz. Set both oscilloscope inputs to 50 Ω .
6. Set function generator output amplitude to 0.1 volt P--P output. Connect equipment as shown in Figure 4--16 with function generator output not connected. Adjust CW and CW VERNIER for a delay line discriminator output of '0' volts as observed on oscilloscope. Note frequency counter reading.
7. Connect function generator output to 8350A FM INPUT (rear panel) and adjust oscilloscope for a clear display of the function generator sinewave.
8. Increase the function generator output amplitude until the deviation becomes non--symmetrical or distorted. Use oscilloscope B input to monitor function generator output. If the output is offset the test is invalid.
9. Mark peak of sinewave on oscilloscope with grease pencil. Remove function generator output from FM INPUT and adjust CW/CW VERNIER to the grease pencil mark. Calculate the difference between the present frequency counter reading and the previous reading (step 6). Verify frequency difference is greater than minimum given in table below for the FM frequency range tested. 9.
10. Set the function generator to 2 MHz then 10 MHz repeating steps 6 through 9 for each frequency and verify the results according to table below.
11. Change mode of plug--in modulation coupling and repeat steps 6 through 10. Verify the results according to the table below.

Modulation Frequency	Direct Coupled	Cross Over Coupled
1 MHz	± 7 MHz	± 7 MHz
2 MHz	± 5 MHz	± 5 MHz
10 MHz	± 1 MHz	± 1 MHz

4--22. AM ON/OFF RATIO AND SQUARE WAVE SYMMETRY TEST

SPECIFICATION:

On/Off Ratio: ≥ 30 dB

Symmetry: 40/60

DESCRIPTION:

The AM ON/OFF ratio is checked on the amplitude axis of a video triggered spectrum analyzer display. The symmetry is checked by calculating the on/off time ratio on the frequency axis.

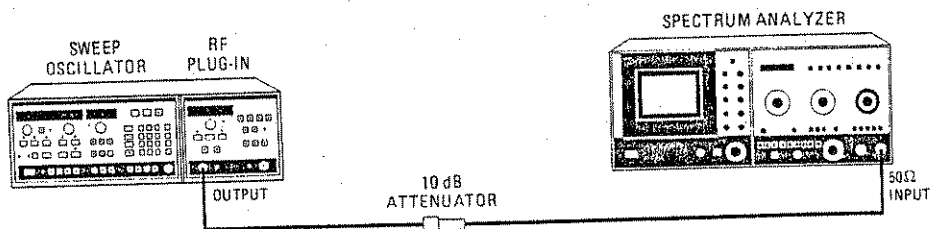

Figure 4--18. AM ON/OFF Ratio and Square Wave Symmetry Test Setup

EQUIPMENT:

Sweep Oscillator	HP 8350A
10 dB Attenuator	Weinshel Model 9--20
Spectrum Analyzer	HP 8565A

PROCEDURE:

1. Connect equipment as shown in Figure 4--18. Press 8350A [INSTR PRESET] [CW] [1] [GHz] and engage [MOD]. Set 83592A POWER LEVEL to +10 dBm.
2. Set controls as follows:

8565A:
Set all Normal settings (controls marked with green)
FREQUENCY BAND GHz 0.01 to 1.8
GHz

4--23. STEP ATTENUATOR ACCURACY TEST (OPTION 002)

SPECIFICATION:

Attenuator Accuracy	Attenuator Setting (dB)						
	10	20	30	40	50	60	70
.01 to 12.4 GHz	0.6	0.7	0.9	1.8	2.0	2.2	2.3
12.4 to 18 GHz	0.7	.9	1.2	2.0	2.3	2.5	2.8
18 to 20 GHz	0.9	1.3	2.5	3.0	3.2	3.3	3.5

DESCRIPTION:

The plug--in RF output is compared to a specially calibrated attenuator and displayed on a spectrum analyzer.

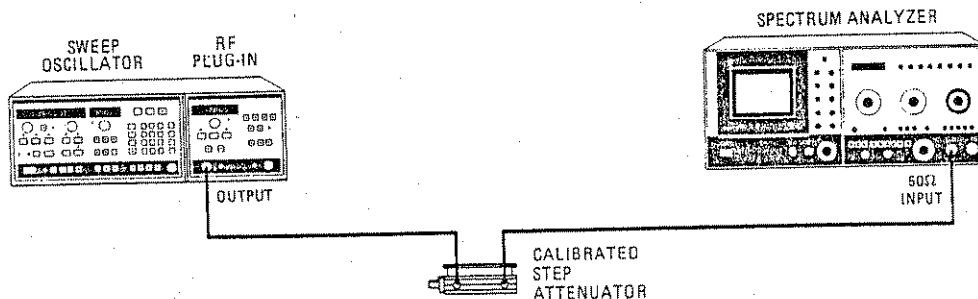

Figure 4--19. Attenuator Accuracy Test Setup

EQUIPMENT:

Sweep Oscillator	HP 8350A
Step Attenuator	HP 8495A Opt. 890
Spectrum Analyzer	HP 8565A

PROCEDURE:

1. Connect equipment as shown in Figure 4--19. Press 8350A [INSTR PRESET],[CW] [4] [GHz]. Set the 83592A POWER LEVEL to +7 dBm.

2. Set controls as follows:

Step Attenuator
ATTENUATION 70 dB

Spectrum Analyzer
Set all normal settings (controls marked with green)
INPUT ATTEN 10 dB
REFERENCE LEVEL -50 dBm
RESOLUTION BANDWIDTH 1 MHz
FREQUENCY SPAN/DIV 5 MHz
FREQUENCY SPAN MODE FULL BAND
VIDEO FILTER Adjust as necessary
FREQUENCY BAND 3.8 to 8.5 GHz

3. Press 8350A [POWER LEVEL], [STEP SIZE], [1], [0], and [dBm/dB].

4. Note the actual attenuation values on the calibrated step attenuator's (Option 890) calibration report at the frequency and attenuation steps used. Calculate the Reference Attenuator Error for each step as shown below; record this error in the Attenuation Error column of table below.

$$\text{Attenuation Error} = (\text{Cal. Ref Atten.} - \text{Cal. Step Atten.}) - (\text{Ref. Setting} - \text{Step Setting})$$

For example, with a Reference setting of 70 dB, the calculation for the 30 dB step setting is as follows (Note that the actual attenuation stepped in this example is 38.75 dB (69.55 dB - 30.80 dB)):

Example Calibration Report values:

70 dB setting is actually 69.55 dB
30 dB setting is actually 30.80 dB

$$\text{Attenuation Error} = (69.55 \text{ dB} - 30.80 \text{ dB}) - (70 \text{ dB} - 30 \text{ dB}) = -1.25 \text{ dB}$$

5. Adjust spectrum analyzer TUNING control to center notch on sweep oscillator output signal. Reduce spectrum analyzer FREQUENCY SPAN/DIV to .2 MHz and recenter TUNING control. Press FREQUENCY SPAN MODE [ZERO SPAN] key and adjust FINE TUNING to peak signal on spectrum analyzer display. Adjust spectrum analyzer REFERENCE LEVEL VERNIER for a trace at the center gradicule line. Press 1 dB/DIV and recenter trace.

6. Press the 8350A [V] key and decrease the reference attenuation by 10 dB.

7. Record the power level variation from the center graticule (reference) on the spectrum analyzer display (be sure to designate the direction of change: + is above and - is below the reference).
8. Algebraically add the Attenuation Error and Deviation from 0 reference and record the sum in the table below. Repeat steps 6 and 7 for the other attenuation values.

Ref Atten Step	Calibrated Change	Deviation from 0 ref	Attenuator Accuracy
70 - 60	-----	-----	-----
60 - 50	-----	-----	-----
50 - 40	-----	-----	-----
40 - 30	-----	-----	-----
30 - 20	-----	-----	-----
20 - 10	-----	-----	-----
10 - 0	-----	-----	-----

Table 4-13 83592A Performance Test Record Card

<u>SPECIFICATIONS TESTED</u> <u>Limits</u>	<u>Step</u>	<u>TEST</u> <u>Conditions</u>	<u>LOWER</u> <u>LIMIT</u>	<u>MEASURED</u> <u>VALUE</u>	<u>UPPER</u> <u>LIMIT</u>
<u>4-13. Frequency Range and Accuracy</u>					
CW Mode					
0.01-20 GHz:	6.	Start frequency = 10 MHz			10 MHz
	7.	Stop frequency = 20 GHz	20 GHz		
Band 1 ±5MHz	8.	CW frequency = 10 MHz	5 MHz		15 MHz
		CW frequency = 1 GHz	0.995 GHz		1.005 GHz
		CW frequency = 2.4 GHz	2.395 GHz		2.405 GHz
Band 1 ±5 MHz		CW frequency = 4 GHz	3.995 GHz		4.005 GHz
		CW frequency = 2.5 GHz	2.495 GHz		2.505 GHz
		CW frequency = 7.0 GHz	6.995 GHz		7.005 GHz
Band 2 ±10 MHz		CW frequency = 10 GHz	9.99 GHz		10.01 GHz
		CW frequency = 7.1 GHz	7.09 GHz		7.11 GHz
		CW frequency = 13.5 GHz	13.49 GHz		13.51 GHz
Band 3 ±15 MHz		CW frequency = 17.0 GHz	16.985 GHz		17.015 GHz
		CW frequency = 14.0 GHz	13.985 GHz		14.015 GHz
		CW frequency = 20.0 GHz	19.985 GHz		20.015 GHz
Swept Frequency Accuracy					
0.01 - 20 GHz: ±50 MHz					
Full Band	11.	Start frequency = 10 MHz	0 MHz		60 MHz
	12.	Stop frequency = 20 GHz	19.95 GHz		20.05 GHz
Band 0 ±15 MHz	13.	Start frequency = 10 MHz	0 MHz		25 MHz
		Stop frequency = 2.4 GHz	2.385 GHz		2.415 GHz
Band 1 ±20MHz		Start frequency = 2.4 GHz	2.38 GHz		2.42 GHz
		Stop frequency = 7.0 GHz	6.98 GHz		7.02 GHz
Band 2 ±25 MHz		Start frequency = 7.0 GHz	6.975 GHz		7.025GHz
		Stop frequency = 13.5 GHz	13.475 GHz		13.525 GHz
Band 3 ±30 MHz		Start frequency = 13.5 GHz	13.47 GHz		13.53 GHz
		Stop frequency = 20 GHz	19.95 GHz		20.05 GHz
Marker Accuracy					
Full Band 0.01 - 20 GHz					
±50 MHz±.5% of sweep width	16.	M1 = 1 GHz	850.05 MHz		1.14995 GHz
		M2 = 4 GHz	3.85005 GHz		4.14995 GHz
		M3 = 8 GHz	7.85005 GHz		8.14995 GHz
		M4 = 14 GHz	13.85005 GHz		14.14995 GHz
		M5 = 18 GHz	17.85005 GHz		18.14995 GHz
Band 0 0.01 - 2.4 GHz					
±15 MHz±.5% of sweep width		M1 = 1 GHz	973.05 MHz		1.02695 GHz
		M2 = 2 GHz	1.97305 GHz		2.02695 GHz
Band 1 2.4 - 7 GHz					
±20 MHz±.5% of sweep width		M1 = 3 GHz	2.957 GHz		3.043 GHz
		M2 = 6 GHz	5.957 GHz		6.043 GHz
Band 2 7 - 13.5 GHz					
±25 MHz±.5% of sweep width		M1 = 8 GHz	7.9425 GHz		8.0575 GHz
		M2 = 12 GHz	11.9425 GHz		12.0575 GHz
Band 3 13.5 - 20 GHz					
±30 MHz±.5% of sweep width		M1 = 15 GHz	14.9375 GHz		15.0625 GHz
		M2 = 18 GHz	17.9375 GHz		18.0625 GHz

SPECIFICATIONS TESTED
Limits

<u>Step</u>	<u>TEST Conditions</u>	<u>LOWER LIMIT</u>	<u>MEASURED VALUE</u>	<u>UPPER LIMIT</u>
<u>4-14. Output Amplitude</u>				
Pwr Lvl Accuracy (Opt. 002):				
5.	Power = +10 dBm (Power = +10 dBm)	+8.5 dBm (+8.3 dBm)		+11.5 dBm (+11.7 dBm)
10.	Power = +10 dBm (Power = +8.5 dBm)	+8.7 dBm (+7 dBm)		+11.3 dBm (+10 dBm)
	Power = +10 dBm (Power = +8 dBm)	+8.7 dBm (+6.5 dBm)		+11.3 dBm (+9.5 dBm)
	Power = +10 dBm (Power = +7 dBm)	+8.6 dBm (+5.4 dBm)		+11.4 dBm (+7.6 dBm)
	Power = +8 dBm (Power = +5 dBm)	+6.6 dBm (+3.4 dBm)		+9.4 dBm (+6.6 dBm)
	Power = +10 dBm (Power = +7 dBm)	+8.5 dBm (+5.3 dBm)		+11.5 dBm (+8.7 dBm)
	Power = +8 dBm (Power = +5 dBm)	+6.5 dBm (+3.3 dBm)		+9.5 dBm (+6.7 dBm)
				+0.2 dB
15.				+18 dBm +17 dBm
17.	Power level = +1 dBm		>15dB/SWP >14dB/SWP	

4-15. Frequency Stability

+5 to -10% V Line Change:

Band 0	1 GHz	<±50 kHz	3. Low line frequency change	<±50 kHz
			4. High line frequency change	<±50 kHz
Band 1	6 GHz	<±50 kHz	5. Low line frequency change	<±50 kHz
			High line frequency change	<±50 kHz
Band 2	12 GHz	<±100 kHz	Low line frequency change	<±100kHz
			High line frequency change	<±100 kHz
Band 3	18 GHz	<±150 kHz	Low line frequency change	<±150 kHz
			High line frequency change	<±150 kHz

Time (10 minutes):

Band 0, 1 GHz:	<±100 kHz	8. Maximum deviation in 10 minutes	<±100 kHz
Band 1, 6 GHz:	<±100 kHz	9. Maximum deviation in 10 minutes	<±100 kHz
Band 2, 12 GHz:	<±200 kHz	Maximum deviation in 10 minutes	<±200 kHz
Band 3, 18 GHz:	<±300 kHz	Maximum deviation in 10 minutes	<±300 kHz

SPECIFICATIONS TESTED Limits	Step	TEST Conditions	LOWER LIMIT	MEASURED VALUE	UPPER LIMIT
10 dB Power Change:					
Band 0, 1 GHz: $\leq +200$ kHz	11.	Frequency change with power			$\leq +200$ kHz
Band 1, 6 GHz: $\leq +200$ kHz		Frequency change with power			$\leq +200$ kHz
Band 2, 12 GHz: $\leq +400$ kHz		Frequency change with power			$\leq +400$ kHz
Band 3, 18 GHz: $\leq +600$ kHz		Frequency change with power			$\leq +600$ kHz
3:1 Load SWR:					
Band 0, 1 GHz: $\leq +100$ kHz	3:1 SWR				$\leq +100$ kHz
Band 1, 6 GHz: ≤ 100 kHz	3:1 SWR				$\leq +100$ kHz
Band 2, 12 GHz: ≤ 200 kHz	3:1 SWR				$\leq +200$ kHz
Band 3, 18 GHz: $\leq +300$ kHz	3:1 SWR				$\leq +300$ kHz
4-16. Residual FM					
Band 0, 1 GHz ≤ 8 kHz	9.	Demodulation voltage _____ Residual FM voltage _____ Residual FM voltage _____			≤ 8 kHz
Demodulation voltage X 14.4 kHz	18.	Residual FM voltage _____ Residual FM voltage _____ Demodulation X14.4 kHz Residual FM voltage _____ Residual FM voltage _____ Demodulation voltage X14.4 kHz Residual FM Voltage _____ Residual FM voltage _____ Demodulation voltage X14.4 kHz			≤ 8 kHz ≤ 8 kHz ≤ 15 kHz ≤ 15 kHz
Band 1, 6 GHz ≤ 15 kHz					
Band 2, 12 GHz ≤ 15 kHz					
Band 3, 18 GHz ≤ 15 kHz					
4-17. Spurious Signals					
Harmonic:					
Band 0 0.01 - 2.4 GHz: > -25 dB	3.	Measure relative to carrier	> -25 dB		
Band 1 2.4 - 7 GHz > -25 dB			> -25 dB		
Band 2, 7 - 13.5 GHz > -25 dB			> -25 dB		
Band 3, 13.5 - 20 GHz > -25 dB			> -25 dB		
Non-harmonic:					
Band 0, 0.01 - 2.4 GHz: > -25 dB			> -25 dB		
Band 1, 2.4 - 7 GHz > -50 dB			> -25 dB		
Band 2, 7 - 13.5 GHz > -50 dB			> -50 dB		
Band 3, 13.5 - 20 GHz > -50 dB			> -50 dB		
4-18. Output VSWR					
0.01 - 2 GHz: ≤ 2.1	6.	Range: .1 - 2 GHz			≤ 2.1
2 - 20 GHz: ≤ 2.1	11.	Range: 2 - 18 GHz			≤ 2.1
4-19. Residual AM					
Band 0, 1 GHz: ≤ -50 dB	5.	Measure relative to carrier			≤ -50 dB
Band 1, 6 GHz: ≤ -50 dB					≤ -50 dB
Band 2, 12 GHz: ≤ -50 dB					≤ -50 dB
Band 3, 18 GHz: ≤ -50 dB					≤ -50 dB

SPECIFICATIONS TESTED

Limits

Step TEST Conditions LOWER LIMIT MEASURED VALUE UPPER LIMIT

4-20. External FM

Direct coupled:

DC - 100 Hz: $\gt +12$ MHz

Cross Over Coupled:

DC - 100 Hz: $\gt +75$ MHz

Direct/Cross Over coupling

100 Hz - 1 MHz: $\gt +7$ MHz

1 - 2 MHz: $\gt +5$ MHz

2 - 10 MHz: $\gt +1$ MHz

1. A3S1: Close switch 5, open 6.

3.

$\gt +12$ MHz

4. A3S1: Close switch 6.

$\gt +75$ MHz

9.

$\gt +7$ MHz

10.

$\gt +5$ MHz

$\gt +1$ MHz

11. A3S1: Change switch 6 from previous setting

$\gt +7$ MHz

$\gt +5$ MHz

$\gt +1$ MHz

4-21. AM On/Off Ratio

Square-Wave Symmetry

On/Off Ratio:

$\gt 30$ dB below specified max leveled power

Symmetry of ON/OFF time:
40/60

1. CW frequency = 4 GHz

Power = +16 dBm

(Opt. 002: Power = +15)

3.

$\gt 30$ dB

4.

40%

60%

4-22. Step Attenuator Accuracy

(Referenced from 0 dB)

0.01 - 12.4 GHz

Attn. Step Accuracy

10 dB $\lt +0.6$ dB

20 dB $\lt +0.7$ dB

30 dB $\lt +0.9$ dB

40 dB $\lt +1.8$ dB

50 dB $\lt +2.0$ dB

60 dB $\lt +2.2$ dB

70 dB $\lt +2.3$ dB

1. CW frequency = 4.0 GHz

Power = +7.0 dBm

2. Reference Attenuation = 70 dB

4. Ref Attn. Attn. + Deviation
Step Error from 0 ref

70 - 60 +

$\lt +0.7$ dB

70 - 50 +

$\lt +0.7$ dB

70 - 40 +

$\lt +0.9$ dB

70 - 30 +

$\lt +1.8$ dB

70 - 20 +

$\lt +2.0$ dB

70 - 10 +

$\lt +2.2$ dB

70 - 0 +

$\lt +2.3$ dB

9. CW frequency = 15 GHz

Power = +7.0 dBm

Reference Attenuation = 70 dB

Ref Attn. Attn. + Deviation
Step Error from 0 ref

70 - 60 +

$\lt +0.7$ dB

70 - 50 +

$\lt +0.9$ dB

70 - 40 +

$\lt +0.9$ dB

70 - 30 +

$\lt +2.0$ dB

70 - 20 +

$\lt +2.3$ dB

70 - 10 +

$\lt +2.5$ dB

70 - 0 +

$\lt +2.8$ dB

12.4 - 18 GHz

Attn. Step Accuracy

10 dB $\lt +0.7$ dB

20 dB $\lt +0.9$ dB

30 dB $\lt +1.2$ dB

40 dB $\lt +2.0$ dB

50 dB $\lt +2.3$ dB

60 dB $\lt +2.5$ dB

70 dB $\lt +2.8$ dB

SPECIFICATIONS TESTED
Limits

Attn. Step	Accuracy
10 dB	<+0.9 dB
20 dB	<+1.5 dB
30 dB	<+2.5 dB
40 dB	<+3.0 dB
50 dB	<+3.2 dB
60 dB	<+3.3 dB
70 dB	<+3.5 dB

TEST
Conditions

10. CW frequency = 18 GHz
Power = +7.0 dBm
Reference Attenuation = 70 dB

Ref Attn. Step	Attn. Error	+ Deviation from 0 ref
70 - 60		+
70 - 50		+
70 - 40		+
70 - 30		+
70 - 20		+
70 - 10		+
70 - 0		+

LOWER
LIMIT

MEASURED
VALUE

UPPER
LIMIT

<+0.9 dB
<+1.5 dB
<+2.5 dB
<+3.0 dB
<+3.2 dB
<+3.3 dB
<+3.5 dB

SECTION V ADJUSTMENTS

5-1. INTRODUCTION

5-2. This section provides adjustment procedures for the Model 83592A RF Plug-in. These procedures should not be performed as routine maintenance but should be used (1) after replacement of a part or component, or (2) when performance tests show that the specifications of Table 1-1 cannot be met. Table 5-1 lists all of the adjustments by reference designation, adjustment name, adjustment paragraph, and description. Each procedure includes a test setup illustration and one or more adjustment location illustrations.

NOTE

Allow the 83592A RF Plug-in and the 8350A Sweep Oscillator to warm up for 30 minutes prior to making any adjustments.

5-3. SAFETY CONSIDERATIONS

5-4. Although this instrument has been designed in accordance with international safety standards, this manual contains information, cautions, and warnings which must be followed to ensure safe operation and to retain the instrument in safe condition. Service and adjustments should be performed only by a skilled person who is aware of the hazard involved.

WARNING

Adjustments in this section are performed with power supplied to the instrument while protective covers are removed. There are voltages at points in the instrument which can, if contacted, cause personal injury. Be extremely careful. Adjustments should be performed only by a skilled person who is aware of the hazard involved.

Capacitors inside the instrument may

still be charged, even if the instrument has been disconnected from its source of supply.

NOTE

Use a non-metallic adjustment tool whenever possible.

5-5. EQUIPMENT REQUIRED

5-6. The equipment required for the adjustment procedures is listed in Section I of this manual. If the test equipment recommended is not available, other equipment may be used if its performance meets the critical specifications listed in the table. The specified equipment required for each adjustment is referenced in each procedure.

5-7. FACTORY-SELECTED COMPONENTS

5-8. Table 5-2 contains a list of factory-selected components that include the reference designation, the related adjustment procedure, the allowable range of values, and the basis of selection. Nominal values are given for the factory-selected components, designated by an asterisk (*), on the schematic diagram and in the replacement parts list. HP Part Numbers for selected values are given in Table 5-3.

5-9. RELATED ADJUSTMENTS

5-10. Interactive adjustments are noted in the adjustment procedures. Table 5-4 indicates by paragraph numbers the adjustments that must be performed if an assembly has been repaired or replaced or if an adjustment has been made to an assembly. Table 5-5 lists the adjustment procedures included in this section.

5-11. ADJUSTMENT PROCEDURE

5-12. Adjustment procedures are given in the proper sequence to allow for interrelated adjustments.

Table 5-1. Adjustable Components

Reference Designation	Adjustment Name	Adjustment Paragraph	Description
A2R1	GAIN	5-24	Sets gain of frequency reference in Bands 1, 2, and 3 (1 V/GHz).
A2R4	OFFSET	5-24	Sets offset of frequency reference in Bands 1, 2, and 3 (1 V/GHz).
A2R6	BAND 0 OFFSET	5-24	Sets offset of frequency reference in Band 0 (1 V/GHz).
A2R23	BAND 0 GAIN	5-24	Sets gain of frequency reference in Band 0 (1 V/GHz).
A3S1	Configuration Switch	5-13	Selects plug-in code, power up power level, FM sensitivity, FM modulation coupling, step attenuator option code, normal/sequential sweep operation, and phase lock operation.
A4R1	SLP	5-25	Slope adjustment for frequency tracking voltage.
A4R2	0 HI	5-25	Sets power calibration at the high end of the power range (+10 dBm) in Band 0.
A4R3	1 HI	5-25	Sets power calibration at the high end of the power range (+10 dBm) in Band 1.
A4R4	BIAS	5-25	Sets bias on the internal detector line for 0 volts with RF power OFF.
A4R5	1 LO	5-25	Sets power calibration at the low end of the power range (-5 dBm) in Bands 1, 2, and 3.
A4R6	0 LO	5-25	Sets power calibration at the low end of the power range (-5 dBm) in Bands 1, 2, and 3.
A4R7	0 MD	5-25	Sets power calibration at the middle of the power range (+7 dBm) in Band 0.
A4R8	1 MD	5-25	Sets power calibration at the middle of the power range (+7 dBm) in Bands 1, 2, and 3.

Table 5-1. Adjustable Components (continued)

Reference Designation	Adjustment Name	Adjustment Paragraph	Description
A4R9	PM	5-29	Sets power meter leveling calibration.
A4R11	GAIN	5-27	Sets gain of U11 Main ALC Amplifier.
A4R47	QFS 1	5-25	Adjusts for zero offset through U7-Q6 log amplifier circuit.
A4R56	QFS 2	5-25	Adjusts for zero offset through U5 log amplifier circuit.
A4R59	QFS 3	5-25	Adjusts for zero offset through U8-Q1 Sample and Hold circuit.
A4R67	QFS 4	5-25	Adjusts for zero offset through U11 Main ALC Amplifier.
A5C14	LD	5-30	Adjusts low frequency for best frequency response flatness through U10.
A5R19	FM	5-30	Adjusts shape of U10 Video Amplifier compensation network response.
A5R34	BP 1	5-26	Breakpoint that works with SL1 (Slope 1) for ALC flatness.
A5R36	BP 2	5-26	Breakpoint that works with SL2 (Slope 2) for ALC flatness.
A5R38	BP 3	5-26	Breakpoint that works with SL3 (Slope 3) for ALC flatness.
A5R40	BP 4	5-26	Breakpoint that works with SL4 (Slope 4) for ALC flatness.
A5R41	SL 1	5-26	Slope adjustment for best ALC flatness.
A5R42	SL 2	5-26	Slope adjustment for best ALC flatness.
A5R43	SL 3	5-26	Slope adjustment for best ALC flatness.

Table 5-1. Adjustable Components (continued)

Reference Designation	Adjustment Name	Adjustment Paragraph	Description
A5R44	SL 4	5-26	Slope adjustment for best ALC flatness.
A5R48	SLP	5-26	Sets overall slope of internal leveling ALC.
A5R50	PWSP	5-28	Sets range for power sweep.
A5R75	HI	5-30	Works in conjunction with C14 to set frequency response flatness of ALC.
A6R9	SRD	5-20,5-21	Adjusts YTM SRD bias to peak power in all bands at low power settings.
A6R16	TV GAIN	5-15	Sets the gain of U6 Tune Voltage buffer amplifier.
A6R21	DAC CAL	5-15	Adjusts the gain of U5 Variable Gain Amplifier during all single band sweeps.
A6R24	B3	5-15,5-23	Adjusts the gain of U5 Variable Gain Amplifier in Band 3 during single band sweeps.
A6R26	B2	5-15,5-23	Adjusts the gain of U5 Variable Gain Amplifier in Band 2 during single band sweeps.
A6R28	B1	5-15,5-23	Adjusts the gain of U5 Variable Gain Amplifier in Band 1 during single band sweeps.
A6R30	B0	5-15	Adjusts the gain of U5 Variable Gain Amplifier in Band 0 during single band sweeps.
A6R34	-10V OFFSET	5-15	Offsets the -10 volt reference voltage to U15.
A6R37	SP	5-15	Offsets input voltage to U24A forward sweep bandswitch amplifier.
A6R61	SB3	5-20,5-21	Adjusts YTM SRD bias at high power levels in Band 3.
A6R62	SB2	5-20,5-21	Adjusts YTM SRD bias at high power levels in Band 2.

Table 5-1. Adjustable Components (continued)

Reference Designation	Adjustment Name	Adjustment Paragraph	Description
A7R10	SGL HI	5-22	Adjusts offset of YTM delay compensation signal at the high end of single band sweeps.
A7R12	SGL LD	5-22	Adjusts offset of YTM delay compensation signal at the low end of single band sweeps.
A7R18	Z	5-16	Adjusts offset of U20 delay compensation amplifier to minimize the difference between CW and $\#F \pm 0$ with YTM delay compensation circuits.
A7R19	GAIN	5-16	Adjusts the Scaled Voltage Tune DAC input signal to U21 YTM Summing Amplifier.
A7R22	ZRD	5-16	Adjusts supply correction voltage to U21 YTM Summing Amplifier.
A7R24	OFS	5-16	Adjusts Offset DAC input signal to U21 YTM Summing Amplifier.
A7R42	SEQ HI	5-22	Adjusts offset of YTM delay compensation signal at high end of sequential band sweeps.
A7R43	SEQ LD	5-22	Adjusts offset of YTM delay compensation signal at low end of sequential band sweeps.
A7R45	SEQ TC	5-22	Adjusts gain of YTM delay compensation signal in sequential band sweeps.
A7R46	SGL TC	5-22	Adjusts gain of YTM delay compensation signal in single band sweeps.
A7R51	B1 OFS	5-20	Adjusts offset of U21 Summing Amplifier in single band sweeps.
A7R55	RTC COMP	5-22	Adjusts the pulse width of the YTM retrace compensation signal.
A7S1	OFFSET	5-20	Adjusts low end of band YTM to Y0 tracking at low sweep speeds.

Table 5-1. Adjustable Components (continued)

Reference Designation	Adjustment Name	Adjustment Paragraph	Description
A752	GAIN	5-20	Adjusts high end of band YTM to YO tracking at slow sweep speeds.
A8R10	HI	5-19	Adjusts YO delay compensation at high frequency end of band.
A8R12	LO	5-19	Adjusts YO delay compensation at low frequency end of band.
A8R18	Z	5-16,5-19	Adjusts offset to minimize the difference between CW and $\#F \pm 0$ with YO delay compensation circuits.
A8R19	GAIN	5-16	Adjusts Scaled Voltage Tune DAC input signal to U20 Summing Amplifier.
A8R22	ZRO	5-16	Adjusts supply correction voltage to U20 Summing Amplifier
A8R24	OFFS	5-16	Adjusts Offset DAC input signal to U20 Summing Amplifier.
A8R44	-10V	5-14	Sets -10 volt reference voltage source.
A8R55	RTC COMP	5-18	Adjusts the pulse width of the YO retrace compensation signal.
A8S1	OFFSET	5-17	Adjusts the low end of band YO frequency accuracy.
A8S2	GAIN	5-17	Adjusts the high end of band YO frequency accuracy.
A13A1R4		none	Factory adjusted.
A14A1R11		none	Factory adjusted.
A14A1R13		none	Factory adjusted.
A14A1R14		none	Factory adjusted.
A14A1R15		none	Factory adjusted.
A14A1R16		none	Factory adjusted.
A14A1R18		none	Factory adjusted.
A16A1R4		none	Factory adjusted.
A16A1R6		none	Factory adjusted.

Table 5-2. Factory Selected Components

Reference Designator	Adjustment Paragraph	Allowable Range of Values	Basis of Selection
ASR31	5-30	75 to 125 Ohms	Selects scaling of current drive of YO FM coil near 100 kHz.
A7R34	none		Selected at factory to correct for frequency nonlinearity in YTM. ↓
A7R35	none		
A7R36	none		
A7R37	none		
A7R38	none		
A7R39	none		
A7R66	none		
A7R67	none		
A7R68	none		
A7R69	none		
A7R70	none		
A7R71	none		
A8R36	none		Selected at factory to correct for frequency nonlinearity in the YO. ↓
A8R37	none		
A8R38	none		
A8R39	none		
A13A1R1	none		Selected at factory to optimize YO bandwidth, power, and harmonics. ↓
A13A1R2	none		

Table 5-3. HP Part Numbers of Standard Value Replacement Components

RESISTORS								
RANGE: 10 to 464K Ohms TYPE: Fixed-Film WATTAGE: .125 at 125°C TOLERANCE: ±1.0%								
Value (Ω)	HP Part Number	C D	Value (Ω)	HP Part Number	C D	Value (Ω)	HP Part Number	C D
10.0	0757-0346	2	464	0698-0082	7	21.5K	0757-0199	3
11.0	0757-0378	0	511	0757-0416	7	23.7K	0698-3158	4
12.1	0757-0379	1	562	0757-0417	8	26.1K	0698-3159	5
13.3	0698-3427	0	619	0757-0418	9	28.7K	0698-3449	6
14.7	0698-3428	1	681	0757-0419	0	31.6K	0698-3160	8
16.2	0757-0382	6	750	0757-0420	3	34.8K	0757-0123	3
17.8	0757-0294	9	825	0757-0421	4	38.3K	0698-3161	9
19.6	0698-3429	2	909	0757-0422	5	42.2K	0698-3450	9
21.5	0698-3430	5	1.0K	0757-0280	3	46.4K	0698-3162	0
23.7	0698-3431	6	1.1K	0757-0424	7	51.1K	0757-0458	7
26.1	0698-3432	7	1.21K	0757-0274	5	56.2K	0757-0459	8
28.7	0698-3433	8	1.33K	0757-0317	7	61.9K	0757-0460	1
31.6	0757-0180	2	1.47K	0757-1094	9	68.1K	0757-0461	2
34.8	0698-3434	9	1.62K	0757-0428	1	75.0K	0757-0462	3
38.3	0698-3435	0	1.78K	0757-0278	9	82.5K	0757-0463	4
42.2	0757-0316	6	1.96K	0698-0083	8	90.9K	0757-0464	5
46.4	0698-4037	0	2.15K	0698-0084	9	100K	0757-0465	6
51.1	0757-0394	0	2.37K	0698-3150	6	110K	0757-0466	7
56.2	0757-0395	1	2.61K	0698-0085	0	121K	0757-0467	8
61.9	0757-0276	7	2.87K	0698 3151	7	133K	0698-3451	0
68.1	0757-0397	3	3.16K	0757-0279	0	147K	0698-3452	1
75.0	0757-0398	4	3.48K	0698-3152	8	162K	0757-0470	3
82.5	0757-0399	5	3.83K	0698-3153	9	178K	0698-3243	8
90.0	0757-0400	9	4.22K	0698-3154	0	196K	0698-3453	2
100	0757-0401	0	4.64K	0698-3155	1	215K	0698-3454	3
110	0757-0402	1	5.11K	0757-0438	3	237K	0698-3266	5
121	0757-0403	2	5.62K	0757-0200	7	261K	0698-3455	4
133	0698-3437	2	6.19K	0757-0290	5	287K	0698-3456	5
147	0698-3438	3	6.81K	0757-0439	4	316K	0698-3457	6
162	0757-0405	4	7.50K	0757-0440	7	348K	0698-3458	7
178	0698-3439	4	8.25K	0757-0441	8	383K	0698-3459	8
196	0698-3440	7	9.09K	0757-0288	1	422K	0698-3460	1
215	0698-3441	8	10.0K	0757-0442	9	464K	0698-3260	9
237	0698-3442	9	11.0K	0757-0443	0			
261	0698-3132	4	12.1K	0757-0444	1			
287	0698-3443	0	13.3K	0757-0289	2			
316	0698-3444	1	14.7K	0698-3156	2			
348	0698-3445	2	16.2K	0757-0447	4			
383	0698-3446	3	17.8K	0698-3136	8			
422	0698-3447	4	19.6K	0698-3157	3			

Table 5-4. Related Adjustments

Assembly Changed or Repaired	Related Assemblies (in order of Adjustments)	Perform the Following Paragraph Number
A1/A2 Front Panel A3 Digital Interface A4 ALC A5 FM A6 Sweep Control A7 YTM Driver A8 YO Driver A11 Cavity Oscillator A12 Switched YIG Tuned Oscillator A13 2.2-7.0 GHz Oscillator A14 Power Amplifier A15 DC Return A16 Modulator/Splitter A17 0.01-2.4 GHz Amplifier A18 Modulator/Mixer AT1 Isolator DC1 Directional Detector DC2 Directional Coupler		

Table 5-5. Adjustments

Paragraph	Adjustments
5-13	Configuration Switch A3S1
5-14	-10 Volt Reference On A8 Y0 Driver
5-15	Sweep Control Adjustments
5-16	Y0 and YTM DAC Calibration
5-17	Preliminary Frequency Accuracy
5-18	Y0 Retrace Compensation
5-19	Y0 Delay Compensation
5-20	Slow Speed YTM to Y0 Tracking
5-21	SRD Bias
5-22	YTM Delay Compensation
5-23	Band Overlap Adjustment
5-24	Frequency Reference 1V/GHz Output
5-25	ALC Adjustments
5-26	ALC Internally Levelled Flatness Adjustment
5-27	ALC Gain Adjustment
5-28	Power Sweep
5-29	Power Meter Leveling Calibration
5-30	FM Driver Adjustments

5-13. CONFIGURATION SWITCH A3S1

REFERENCE:

Performance Test: 8350A Paragraph 4-13.
Service Sheet: A3

DESCRIPTION:

Switch A3S1 is set at the factory for a combination of operating modes. (Refer to Table 5-6.) Other operating modes are selected by setting the eight switches on A3S1.

PROCEDURE:

NOTE

All adjustment procedures assume that A3S1 is set to the factory setting (unless otherwise specified in the test. If other procedures are to be performed, set A3S1 to the factory setting until the procedures are completed, then set A3S1 to the desired operating mode before putting the instrument back in service.

1. Refer to Table 5-6 and determine if factory selected mode set at A3S1 is correct for your application.
2. Set configuration switch A3S1 (Figure 5-1) for the desired operating mode.
3. Press [INSTR PRESET] to set the instrument into the operating mode selected by the configuration switch.

NOTE

[INSTR PRESET] must be pressed after the configuration switch positions are modified in order to immediately set the instrument to the desired operating mode set by the configuration switch.

CONFIGURATION
SWITCH
A3S1

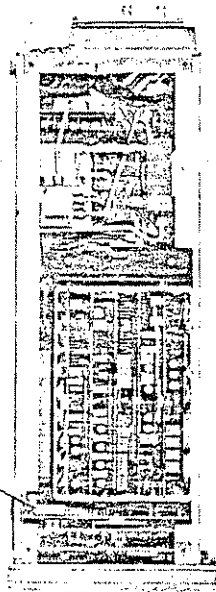

FRONT

Figure 5-1. Configuration Switch A3S1 Location

Table 8-7. Configuration Switch on A3 Digital Interface Board

Description	Switch Number							
	1	2	3	4	5	6	7	8
Plug-In: 83592A	x	x	x	x	x	x	x	x
Normal Sweep	0	x	x	x	x	x	x	x
Sequential Sweep Only	1	x	x	x	x	x	x	x
*No RF Power at Power-Up	x	x	x	1	x	x	x	x
Maximum RF Power at Power-Up	x	x	x	0	x	x	x	x
-6MHz/V FM Sensitivity	x	x	x	x	1	x	x	x
-20MHz/V FM Sensitivity	x	x	x	x	0	x	x	x
Direct-Coupled FM Modulation (-20 MHz/V)	x	x	x	x	x	1	x	x
Cross-Over Coupled FM Modulation	x	x	x	x	x	0	x	x
Step Attenuator Option	x	x	x	x	x	x	1	x
No Step Attenuator Option	x	x	x	x	x	x	0	x
AUX OUT Phase Lock	x	x	x	x	x	x	x	1
RF OUTPUT Phase Lock	x	x	x	x	x	x	x	0

Note:

- 1 = Switch Open = High
- 0 = Switch Closed = Low (Ground)
- x = Don't Care

* With the configuration switch set for an Instrument Preset condition of 'RF Power OFF', bias is removed from A13 YIG Oscillator. In addition, the 8350A microprocessor issues a blanking pulse to the plug-in. L RFB (Low = RF Blank) biases the modulator on hard, closing off the RF signal path. When RF power is manually turned on, via the front panel pushbutton, L RFB remains low for a short period to allow the RF microcircuit components to reach full capacity before releasing the ALC amplifier. This prevents the ALC loop from correcting for a large error voltage at initial power up, thus preventing overshoot.

Switch No.	Position
1	1
2	1
3	0
4	0
5	0
6	0
7	*
8	x

*"1" if Opt. 002 installed; "0" if Opt. 002 not installed.

NOTE

Switch A3S1 is set from the factory as follows:

A3S1

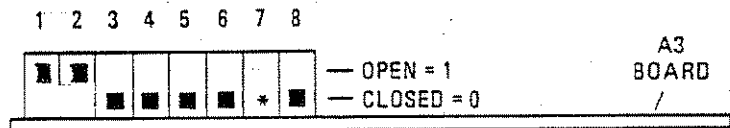

■ = DEPRESSED SWITCH POSITION.

5-14. -10 VOLT REFERENCE ON A8 YO DRIVER

REFERENCE:

Performance Test: 8350A Paragraph 4-13
Service Sheet: A8

9,802

DESCRIPTION:

The -10 volt reference voltage source on the A8 YO Driver board is used as a reference voltage for the DACs on the A4 ALC, A6 Sweep Control, the A7 YTM Driver, and the A8 YO Driver boards. The -10 volt reference output voltage is set by the ABR44 -10V adjustment while monitoring ABTP12.

EQUIPMENT:

Digital Voltmeter	HP 3455A
Sweep Oscillator	HP 8350A

PROCEDURE:

1. Set up the equipment as shown in Figure 5-2. Connect the DVM to ABTP12 (-10V) with reference to ABTP1 (GND ANLG).
2. Adjust ABR44 -10V for a DVM reading of -10 ± 0.001 Vdc. Refer to Figure 5-3 for -10 volt reference adjustment location.

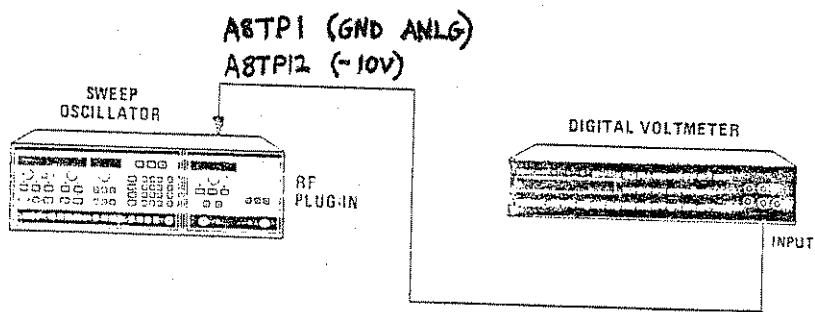

Figure 5-2 -10 Volt Reference Test Setup

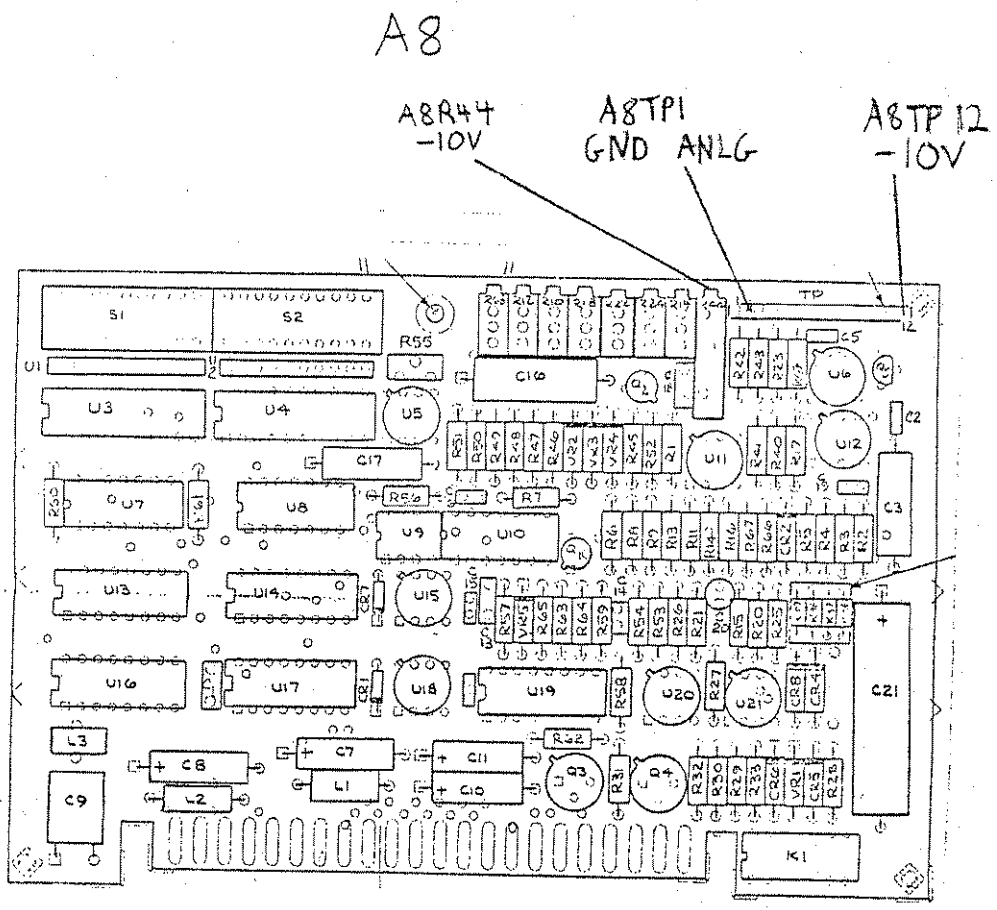

Figure 5-3, -10V Reference Adjustment Location

5-15. SWEEP CONTROL ADJUSTMENTS

REFERENCE:

Performance Test: 8350A Paragraph 4-13
Service Sheet: A6

DESCRIPTION:

EQUIPMENT:

Digital Voltmeter	HP 3455A
Oscilloscope	HP 1740A
1:1 Probe	HP 10008B
Sweep Oscillator	HP 8350A

PROCEDURE:

1. Ensure that A3S1 switch position 1 is in the OPEN (up) position. Refer to Adjustment Paragraph 5-13 for instructions on setting A3S1.
2. Set up the equipment as shown in Figure 5-4 with the DVM connected to A6TP9 (V TUNE) with the reference probe connected to A6TP10 (V TUNE RET). Do not connect the oscilloscope probe yet. Allow the instrument to warm up for 1 hour.
3. On the 8350A, press [INSTR PRESET CW 20 GHz].
4. Adjust the 8350A FREQ VERNIER for a DVM reading of 10 ± 0.001 Vdc.

NOTE

The following voltage measurement procedures on the A6 Sweep Control board are made with the DVM reference probe connected to A8TP1 (which is electrically the same as motherboard ground).

5. Connect the DVM to A6TP5 and adjust A6R16 (TV GAIN) for a

DVM reading of -10 ± 0.001 Vdc. Refer to Figure 5-5 for sweep control adjustment locations.

6. Connect the DVM to A6TP4 and adjust A6R21 (DAC CAL) for a DVM reading of 0 ± 0.001 Vdc. *0.036*
7. Connect the DVM to A6TP8 (BV TUNE) and adjust A6R34 for a DVM reading of -10 ± 0.001 Vdc.
8. On the 8350A, press [CW 13.5 GHz].
9. Connect the DVM to A6TP5 and adjust the 8350A FREQ VERNIER control for a DVM reading of -6.74837 ± 0.00005 Vdc.
10. Connect the DVM to A6TP8 and adjust A6R24 (B3) for a DVM reading of 0 ± 0.001 Vdc. *12*
11. On the 8350A, press [CW 7 GHz].
12. Connect the DVM to A6TP5 and adjust the 8350A FREQ VERNIER control for a DVM reading of -3.49675 ± 0.00005 Vdc.
13. Connect the DVM to A6TP8 and adjust A6R26 (B2) for a DVM reading of 0.001 Vdc.
14. On the 8350A, press [CW 2.4 GHz].
15. Connect the DVM to A6TP5 and adjust the 8350A FREQ VERNIER control for a DVM reading of 1.19560 ± 0.00005 Vdc.
16. Connect the DVM to A6TP8 and adjust A6R28 (B1) for a DVM reading of 0 ± 0.001 Vdc.
17. On the 8350A, press [CW 10 MHz].
18. Connect the DVM to A6TP5 and adjust the 8350A FREQ VERNIER control for a DVM reading of 0 ± 0.00005 Vdc.
19. Connect the DVM to A6TP8 and adjust A6R30 (B0) for a DVM reading of 0 ± 0.001 Vdc.
20. On the 8350A, press [INSTR PRESET].
21. Connect the oscilloscope probe to A6TP8. Set the oscilloscope settings as follows:

Mode	A versus B
Vertical Sensitivity	0.5 V/Div.
Coupling	DC

XY (Sweep on X)
TP5 *XY*

22. Adjust the oscilloscope vertical position control to set the top of the first full 0 to -10 volt sweep ramp on the centerline as shown in Figure 5-6.
23. Adjust A6R37 (SP) to bring the tops of the remaining 0 to -10 volt sweep ramps to the center graticule as shown in Figure 5-6.
24. If A3S1 switch position 1 was modified in step 1 of this procedure, reset it to the closed (down) position as described in Adjustment Paragraph 5-13 before continuing with the adjustment procedures.

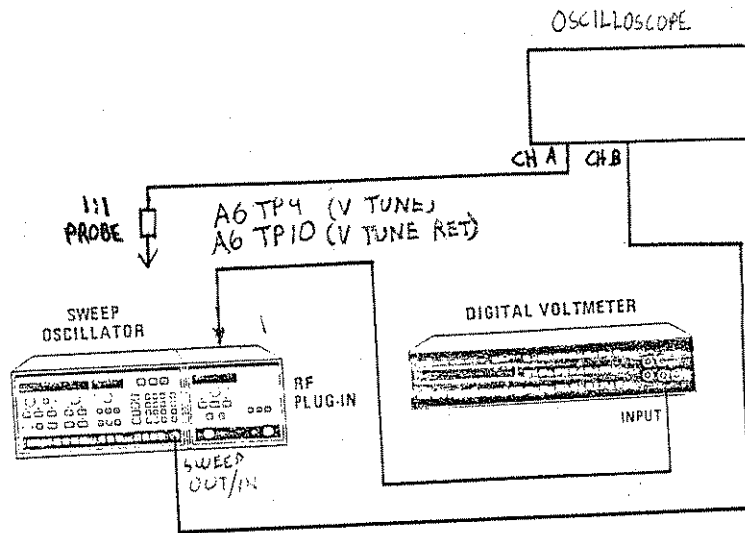
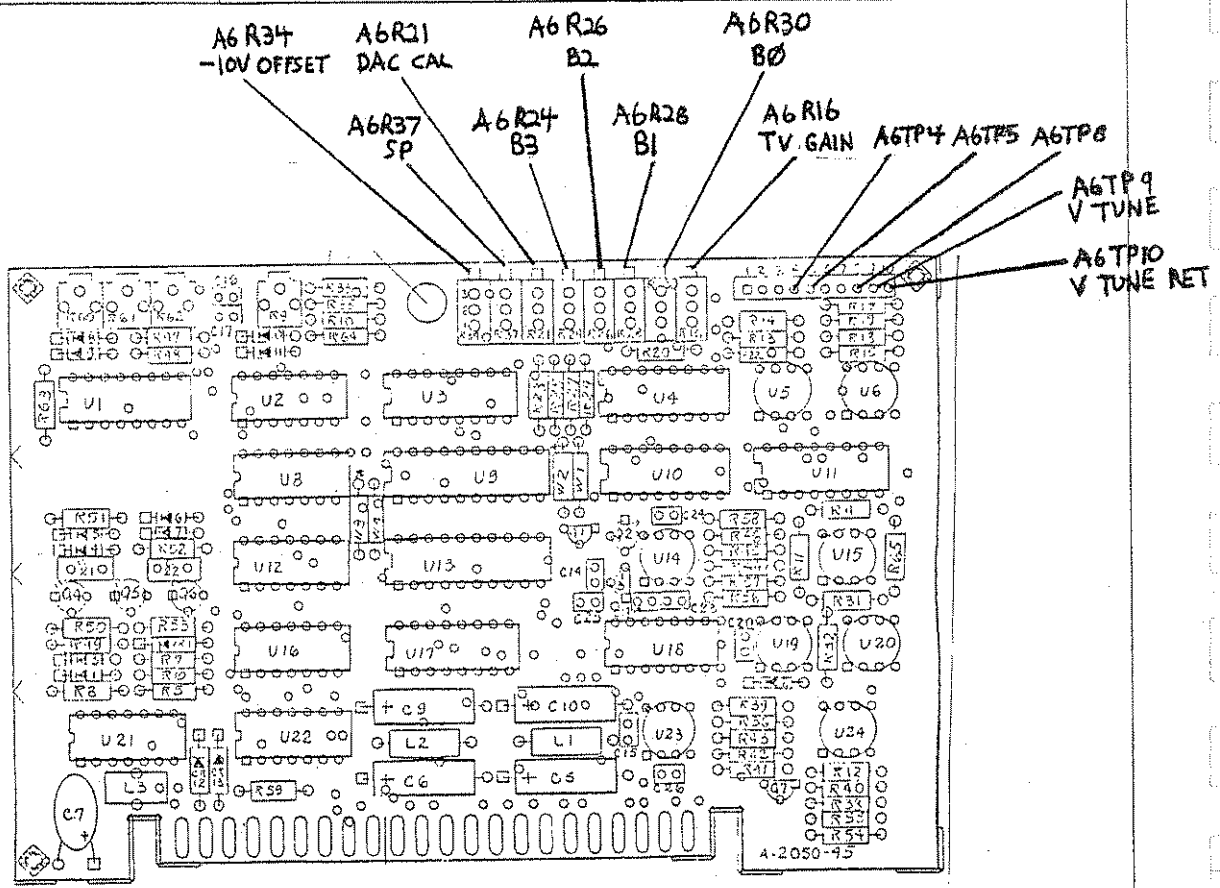

Figure 5-4. Sweep Control Adjustments Test Setup.

A6



A8

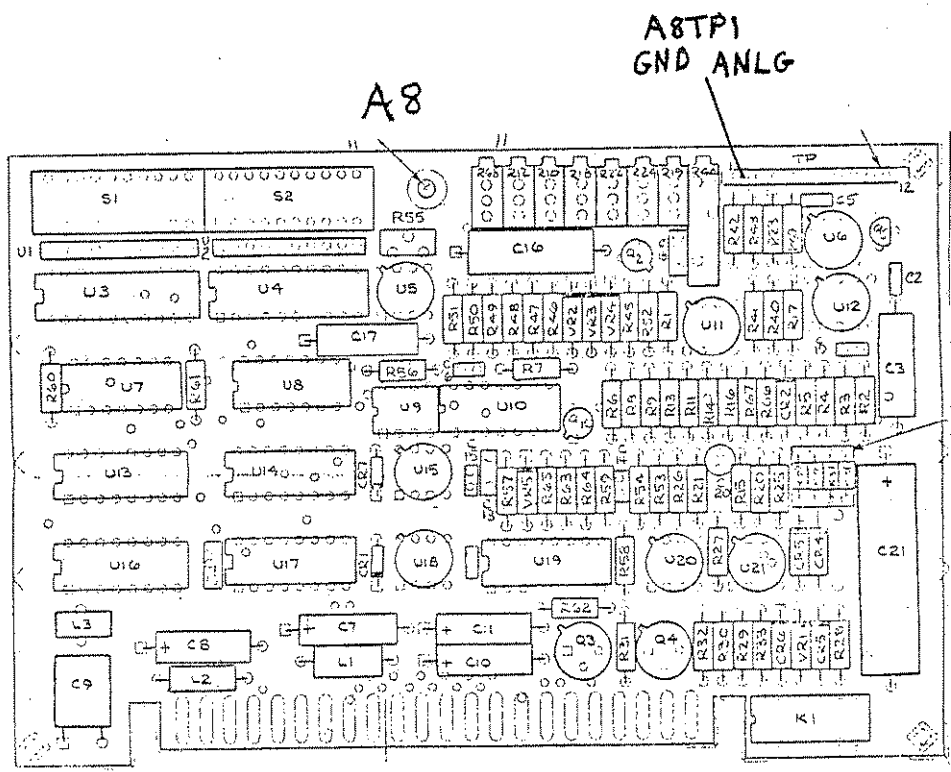
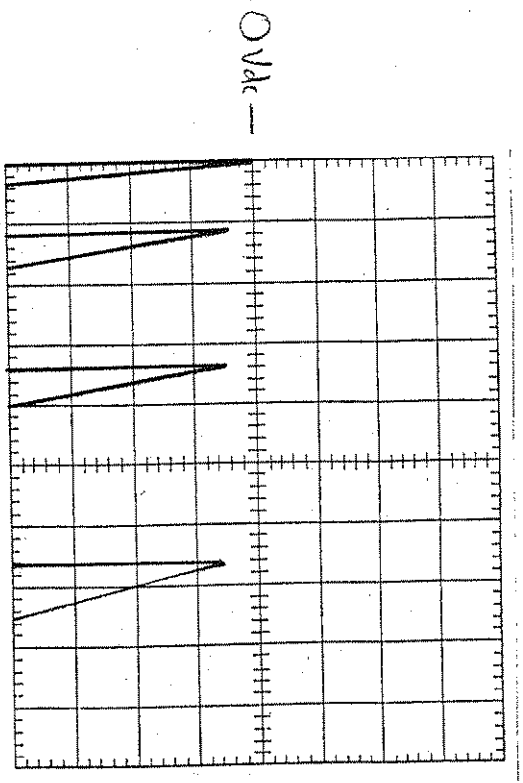

Figure 5-5. Sweep Control Adjustment Locations

12381
 12382
 12383
 12384
 12385
 12386
 12387
 12388
 12389
 12390
 NATIONAL
 MADE IN U.S.A.

Adjust oscilloscope vertical position to set top of first ramp to O_{Vdc} .



Adjust A6R37 (GP) to level the tops of all ramps to O_{Vdc} .

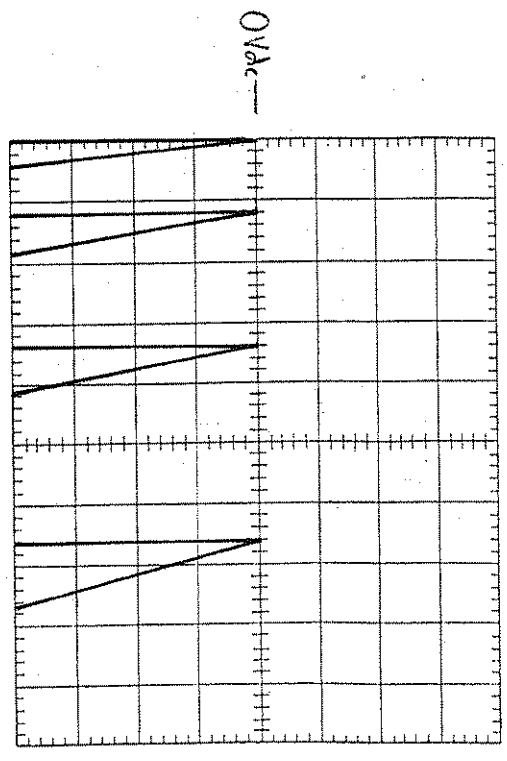

Sweep Mode : A $\frac{100ns}{50ns}$ B
 Vertical Sensitivity = 0.15 V/DIV

Figure 5-6. Sweep Control Adjustment Waveforms

5-16. YO AND YTM DAC CALIBRATION

sig. d.
SHIFT 00 2 6 8 9 0
M2 00 ↑ 00 ↑
00 ↑ 00

REFERENCE:

Performance Test: 8350A Paragraph 4-13
Service Sheet: A7 and A8

DESCRIPTION:

EQUIPMENT:

Digital Voltmeter HP 3455A
Sweep Oscillator HP 8350A

PROCEDURE:

NOTE

This procedure assumes that steps 2, 3, and 4 in Paragraph 5-15 Sweep Control Adjustments have been done to ensure that the tune voltage at A6TP9 (V TUNE) has been properly adjusted.

1. Connect the equipment as shown in Figure 5-7 with the DVM connected to A8TP6 (YO COLLECTOR) and A7TP8 (+20V FREQ REF). Refer to Figure 5-8 for test point and adjustment locations. Allow the RF plug-in to warm up for 1 hour.

1615

2. On the 8350A, press [SHIFT 00 2 GHz 8 0 ↑ 0 0 ↑ 0 0 ↑ 0 0 ↑ 0 01]. Refer to Figure 5-9 for a diagram of the 8350A front panel Hexadecimal Entry Key locations. The 8350A FREQUENCY display should now show 2C83 and the FREQUENCY/TIME display should show 00.

3. Adjust A8R22 (ZA0) for a DVM reading of -7.000 ± 0.001 Vdc.

4. On the 8350A, press [↓ ↓ ↓ 0 BKSP ↑ 0 BKSP ↑ 0 BKSP ↑ 0 BKSP]. The FREQUENCY display should now show 2C80 and the FREQUENCY/TIME display should show 0F.

5. Adjust A8R24 (OFS) for a DVM reading of -20.000 ± 0.001 Vdc.

6. On the 8350A, press [↓ ↓ ↓ BKSP 0 ↑ BKSP 0 ↑ BKSP 0 ↑

BKSP 01. The FREQUENCY display should now show 2C83 and the FREQUENCY/TIME display should show F0.

7. Adjust A8R19 (GAIN) for a DVM reading of -26.500 ± 0.001 Vdc.
8. On the 8350A, press [▲▲▲▲▲ 0 0 ▲ 0 0 ▲ 0 0 ▲ 0 01. The FREQUENCY display should now show 2C8b and the FREQUENCY/TIME display should show 00.
9. Connect the DVM to A7TP3 (YTM COLLECTOR) with the reference probe still at A7TP8 (+20V FREQ REF). Adjust A7R22 (ZRO) for a DVM reading of -3.000 ± 0.001 Vdc.
10. On the 8350A, press [▼▼▼ 0 BKSP ▲ 0 BKSP ▲ 0 BKSP ▲ 0 BKSP]. The FREQUENCY display should now show 2C88 and the FREQUENCY/TIME display should show 0F.
11. Adjust A7R24 (OFS) for a DVM reading of -19.500 ± 0.001 Vdc.
12. On the 8350A, press [▼▼▼ BKSP 0 ▲ BKSP 0 ▲ BKSP 0 ▲ BKSP 0]. The FREQUENCY display should now show 2C8b and the FREQUENCY/TIME display should show F0.
13. Adjust A7R19 (GAIN) for a DVM reading of -9.500 ± 0.001 Vdc.
14. On the 8350A, press [INSTR PRESET SHIFT CW].
15. Connect the DVM to A7TP4 with reference to A8TP1 (GND ANLG).
16. Adjust A7R18 (Z) for a DVM reading of 0.000 ± 0.001 Vdc.
17. Connect the DVM to A8TP9 with reference to A8TP1 (GND ANLG).
18. Adjust A8R18 (Z) for a DVM reading of 0.000 ± 0.001 Vdc.

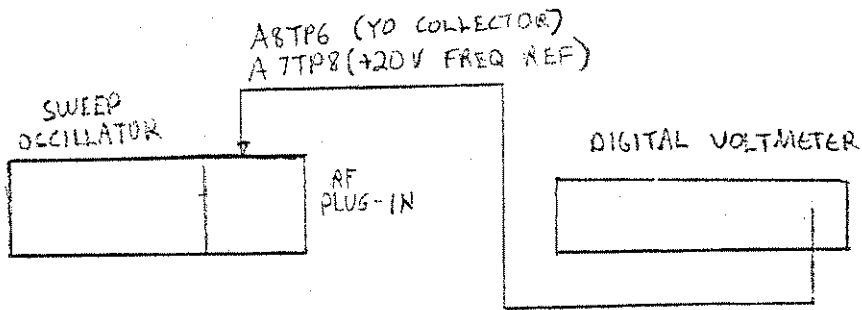

Figure 5-7. Y0 and YTM DAC Calibration Test Setup

42352 100 SHEETS 3 SQUARE
 42353 200 SHEETS 3 SQUARE
 NATIONAL INSTRUMENTS

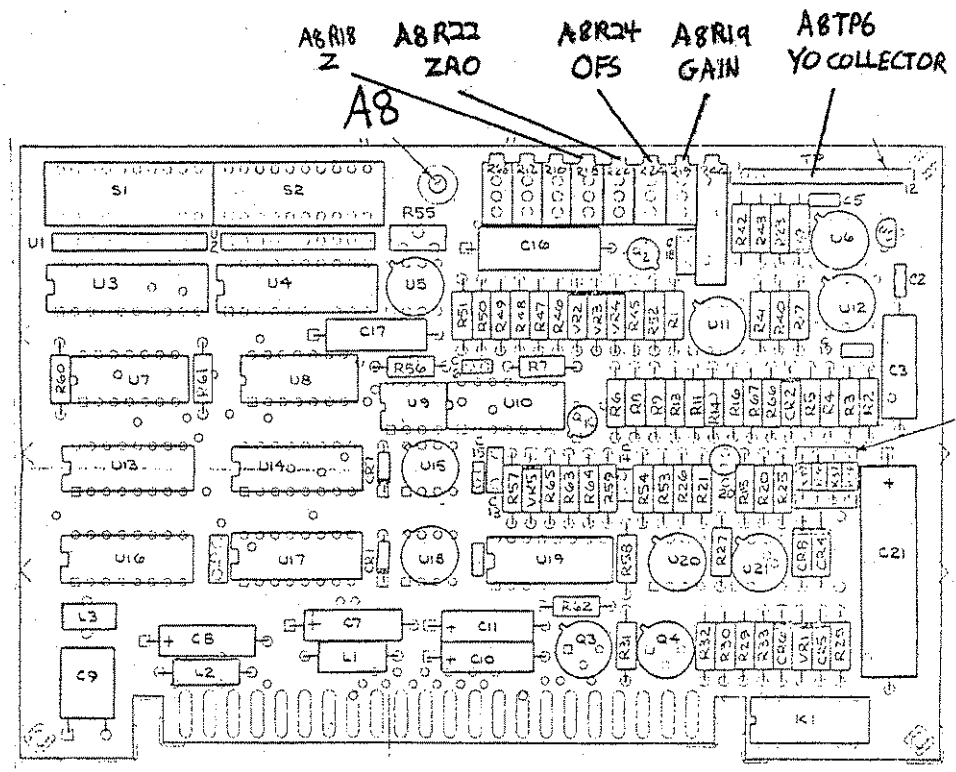
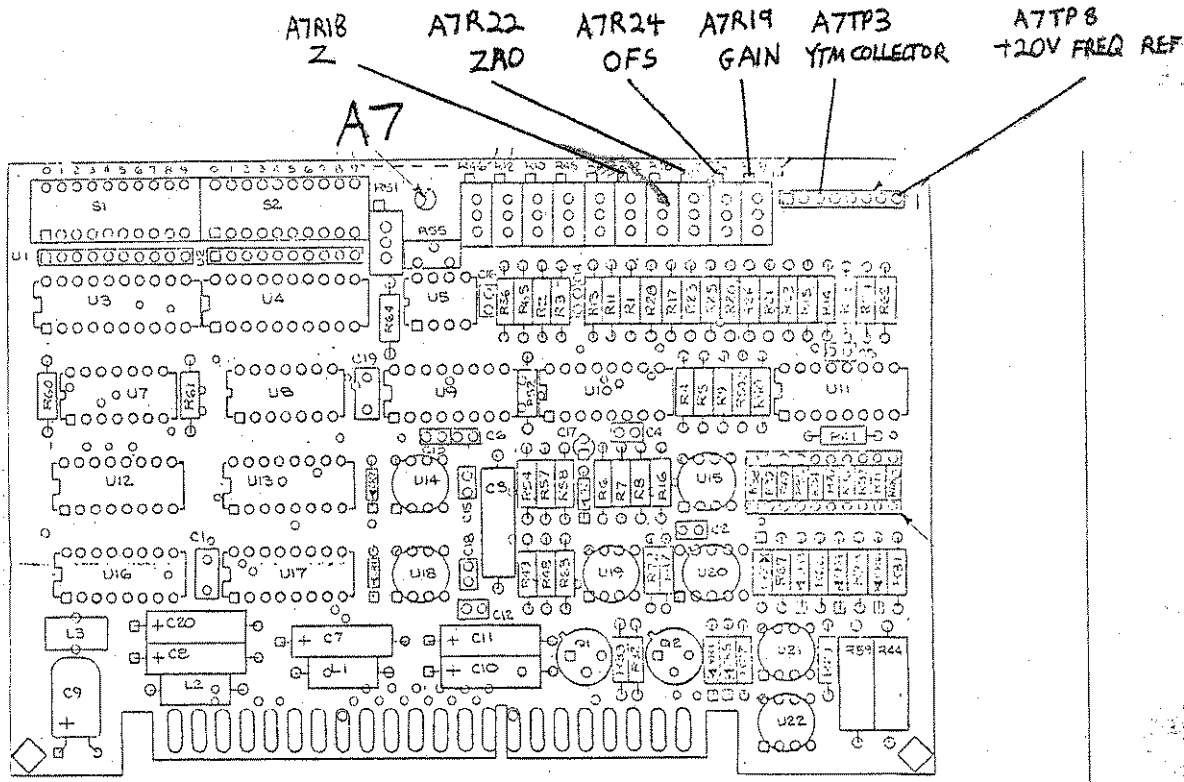

Figure 5-8. YO and YTM DAC Calibration Adjustment Locations

42-382 100 SHEETS 3 SQUARE
42-383 100 SHEETS 3 SQUARE
NATIONAL

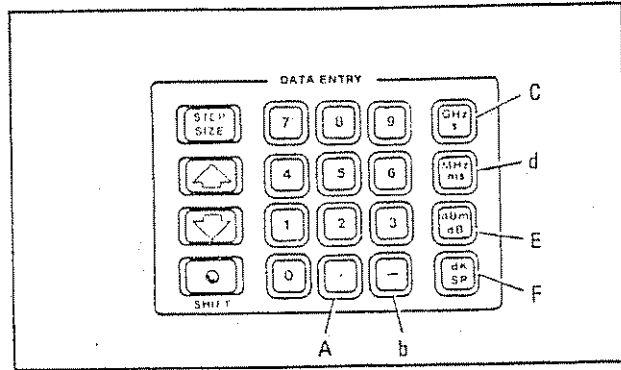

Figure 5-9 Front Panel Hexadecimal-Entry Keys

5-17. PRELIMINARY FREQUENCY ACCURACY

REFERENCE:

Performance Test: 8350A Paragraph 4-13
Service Sheet: A8

DESCRIPTION:

EQUIPMENT:

Frequency Counter	HP 5343A
10 dB Attenuator	Weinschel Model M9-10
Sweep Oscillator	HP 8350A

PROCEDURE:

1. Connect the equipment as shown in Figure 5-10 with the Frequency Counter connected to the 83592A rear panel AUX OUTPUT connector through the 10 dB attenuator. Allow the equipment to warm up for 1 hour.
2. Adjust the 83592A FREQ CAL control to the center of its mechanical range.
3. On the 8350A, press [INSTR PRESET CW 6.9 GHz SAVE 1].
4. On the 8350A, press [CW 13.5 GHz SAVE 2].
5. On the 5343A, press [SET .2 ENTER]. This sets the Frequency Counter in a mode which displays twice the input frequency. (This step is necessary to compensate for the frequency of the rear panel AUX OUTPUT (which is the Y0 fundamental frequency, approximately half of the 8350A displayed frequency in Band 2).

Low End Frequency Calibration

6. On the 8350A, press [RECALL 2 RECALL 1]. The 8350A FREQUENCY display should show 6.900 GHz.
7. On the 8350A, press [SHIFT 90] to select the low end frequency calibration mode.
8. Adjust the 83592A POWER control if necessary to display 6.900 ± 0.003 GHz on the Frequency Counter.

9. Set switch A8S1 for the hexadecimal value displayed in the 83592A POWER display. Refer to Figure 5-11 for the location of the frequency calibration switches. Refer to Figure 5-12 for an illustration of the calibration switch configuration.
10. On the 8350A, press [RECALL 1]. Verify that the frequency counter reads 6.900 ± 0.010 GHz.

High End Frequency Calibration

11. On the 8350A, press [RECALL 2]. The 8350A FREQUENCY display should show 13.500 GHz.
12. On the 8350A, press [SHIFT 91] to select the high end frequency calibration mode.
13. Adjust the 83592A POWER control if necessary to display 13.500 ± 0.003 GHz on the Frequency Counter.
14. Set switch A8S2 for the value displayed in the 83592A POWER display in the same manner as that described in step 8.
15. On the 8350A, press [RECALL 2]. Verify that the Frequency Counter reads 13.500 ± 0.010 GHz.
16. Manually adjust the 8350A FREQUENCY control across band 2 and check for Frequency Counter readings which correspond to the displayed 8350A FREQUENCY display reading (± 10 MHz).

Frequency
Sweep
5 SQUARE
WAVE
SHAPES
20-300
MHz
NATIONAL
MODEL

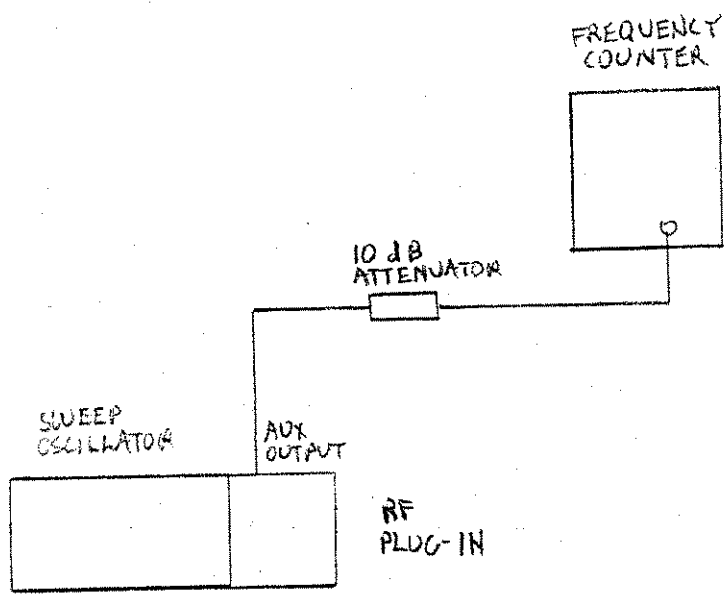

Figure 5-10. Preliminary Frequency Accuracy Test Setup

5-18. YO RETRACE COMPENSATION

REFERENCE:

Performance Test: 8350A Paragraph 4-13
Service Sheet: A8

DESCRIPTION:

EQUIPMENT:

Oscilloscope	HP 1740A
Crystal Detector	HP 8473C
Frequency Meter (3.7 to 12.4 GHz)	HP 537A
Frequency Meter (0.96 to 4.2 GHz)	HP 536A
Sweep Oscillator	HP 8350A

PROCEDURE:

NOTE

This procedure requires that A361 is set to the factory-set position. Refer to Figure 5-6.

1. Connect the equipment as shown in Figure 5-13 with the oscilloscope connected through the detector and Frequency Meters to the 83592A rear panel AUX OUTPUT. On the 8350A, press [INSTR PRESET RF BLANK ON]. Allow the equipment to warm up for 1 hour.

2. Set the oscilloscope controls as follows:

Channel B	DC
Channel B Sensitivity	2 Volts/Div.
Horiz. Sweep	5 mSEC/Div.
Delayed Sweep	0.5 mSEC/Div.
Display	CHOP
Trigger	B
Sweep Mode	MAIN

3. Adjust the vertical sensitivity of Channel A on the oscilloscope to bring the trace to center screen.

4. Set the 536A Frequency Meter to 2.35 GHz.

5. Use the delayed sweep vernier to set the delayed part of

the trace on the bandswitch point between Band 1 and Band 2 as shown in Figure 5-14.

6. On the oscilloscope, go to delayed sweep and fine adjust the Frequency Meter to set the frequency pip near center screen.
7. Start with A8R55 (RTC COMP) fully clockwise and adjust it for the widest and flattest pip while moving the Frequency Meter to track the bandswitch frequency. A well adjusted retrace compensation pulse is shown in Figure 5-14.
8. Select main sweep on the oscilloscope and adjust the delayed sweep vernier to move the delayed portion of the sweep to the bandswitch point between Band 2 and Band 3.
9. Set the 537A Frequency Meter to 4.49 GHz.
10. On the oscilloscope, go to delayed sweep and fine adjust the wavemeter to set the frequency pip near center screen. If the previous Band 1 to Band 2 adjustment was made properly, this bandswitch point will look the same. If it does not, repeat steps 4 through 10 for the best compromise.

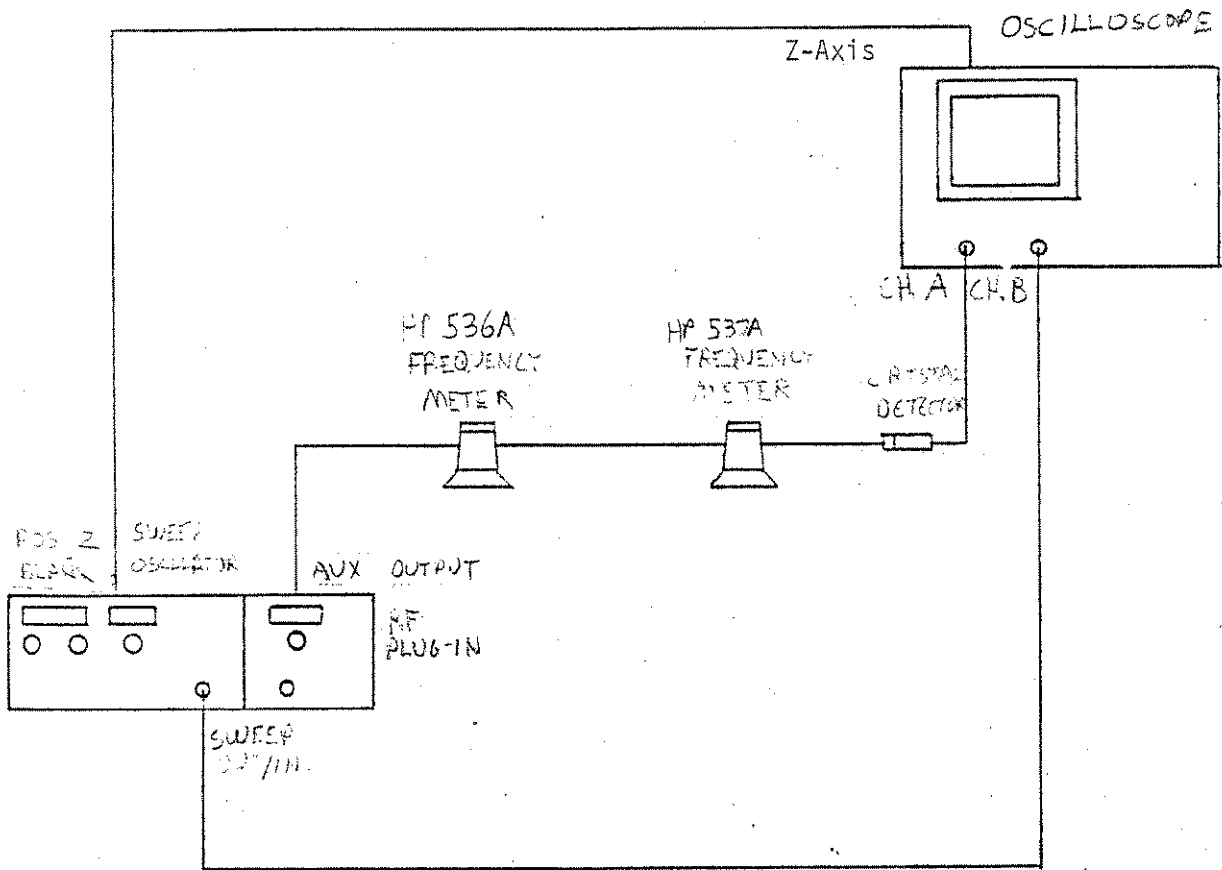

Figure 5-13. YD Retrace Compensation Test Setup

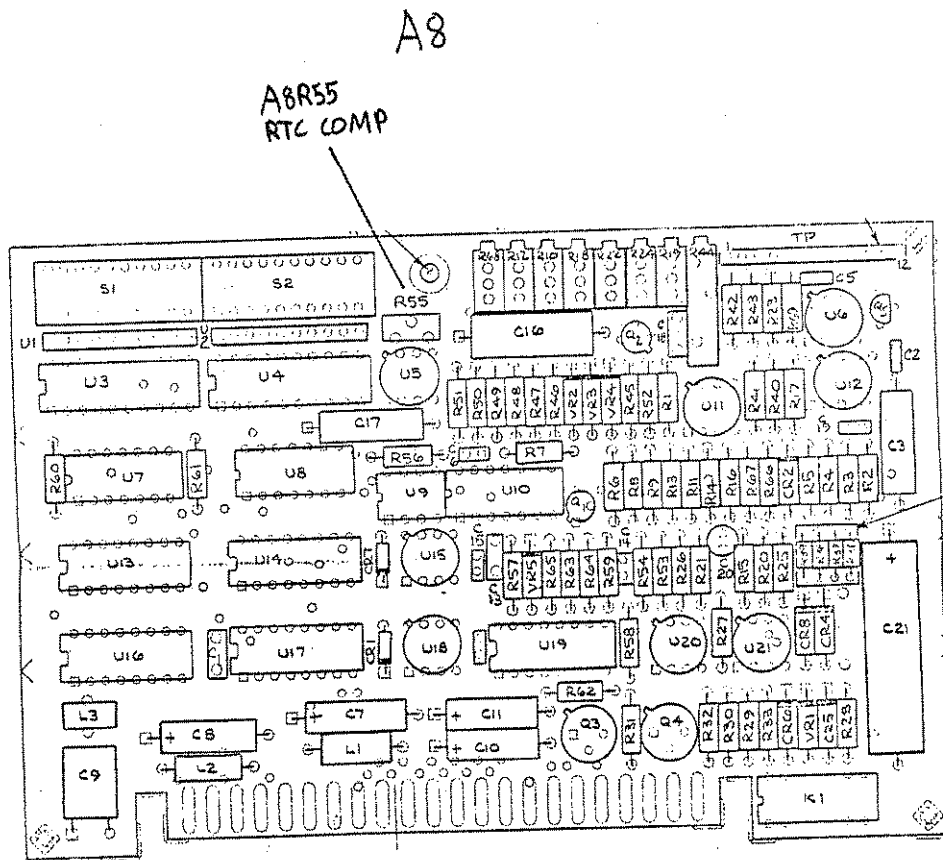

Figure 5-15. Y0 Retrace Compensation Adjustment Location

5-19. YO DELAY COMPENSATION

REFERENCE:

Performance Test: 8350A Paragraph 4-13
Service Sheet: A8

DESCRIPTION:

This circuit compensates for the delay in the RF sweep output that occurs at fast sweep speeds. An external frequency meter is used to generate a frequency-dependent marker which is aligned with a tuning ramp-dependent marker generated from the 8350A mainframe. Sweep time is decreased and delay in the YO is observed as the difference between the two marker pips.

Delay compensation adjustments are made while observing the shift between marker pips at a sweep time of 10 milliseconds (worst case for single-band sweeps). At sweep times greater than 100 mSEC, delay should not exceed ± 15 MHz (the difference between CW and Swept Frequency accuracies).

EQUIPMENT:

Digital Voltmeter	HP 3455A
Oscilloscope	HP 1740A
Frequency Meter (0.96 to 4.2 GHz)	HP 536A
Frequency Meter (12.4 to 18 GHz)	HP P532A
Crystal Detector	HP 8473C
Sweep Oscillator	HP 8350A

PROCEDURE:

NOTE

This procedure requires that A3S1 is set to the factory-set position. Refer to Figure 5-6.

1. Connect the equipment as shown in figure 5-16. On the 8350A, press [INSTR PRESET] and allow the equipment to warm up for 1 hour.
2. Set the oscilloscope for A versus B sweep mode to obtain a display of amplitude versus frequency.
3. On the 8350A, press [CW].
4. Measure and note the voltage at A8TP9.

5. On the 8350A, press [CF Δ F 0 MHz].
6. Adjust A8R18 (Z) for a DVM reading that is equal to the same reading as was noted in step 4. Remove the DVM test leads.
7. On the 8350A, enter the front panel data as follows:

Press [INSTR PRESET].
Press [START 6.9 GHz].
Press [STOP 13.5 GHz].
Press [SWEEP TIME 10 mSEC].
Press [MKR M1 7.2 GHz].
Press [AMPTD MKR].
Press [RF BLANK].
Press [SAVE 2].
8. On the 8350A, press [SWEEP TIME 200 mSEC].
Press [SAVE 1].
9. On the 8350A, press [MKR M2 13.2 GHz].
Press [SAVE 3].
10. On the 8350A, press [SWEEP TIME 10 mSEC].
Press [SAVE 4].
11. On the 8350A, press [RECALL 1].
12. Expand the oscilloscope trace at the marker by centering the marker on the oscilloscope then selecting [MAG X10]. Set the 537A Frequency Meter so that the peak of the pip is on the leading edge of the 7.2 GHz marker.
13. On the 8350A, press [RECALL 2].
14. Adjust A8R12 (LO) so that the peak of the 537A Frequency Meter pip is on the leading edge of the marker.
15. Verify that the delay is accurate by manually adjusting the sweep time from 10 mSEC to 200 mSEC. Reset A8R12 (LO) as necessary to compensate for the best overall delay setting (minimum delay per change in sweep time). The position of the 537A Frequency Meter pip should typically stay within \pm 15 MHz as read on the Frequency Meter across the 10 mSEC to 200 mSEC range.
16. On the 8350A, press [RECALL 3].
17. Set the P532A Frequency Meter so that the peak of the pip is coincident with the leading edge of the 13.2 GHz marker.

18. On the 8350A, press [RECALL 4].
19. Adjust A8R10 (HI) so that the peak of the Frequency Meter is coincident with the leading edge of the marker.
20. Verify that the delay is accurate by manually adjusting the sweep time from 10 mSEC to 200 mSEC. Reset A8R10 (HI) as necessary to compensate for the best overall delay setting (minimum delay per change in sweep time). The position of the Frequency Meter pip should typically stay within ± 15 MHz as read on the P532A Frequency Meter across the 10 mSEC to 200 mSEC sweep speed range.

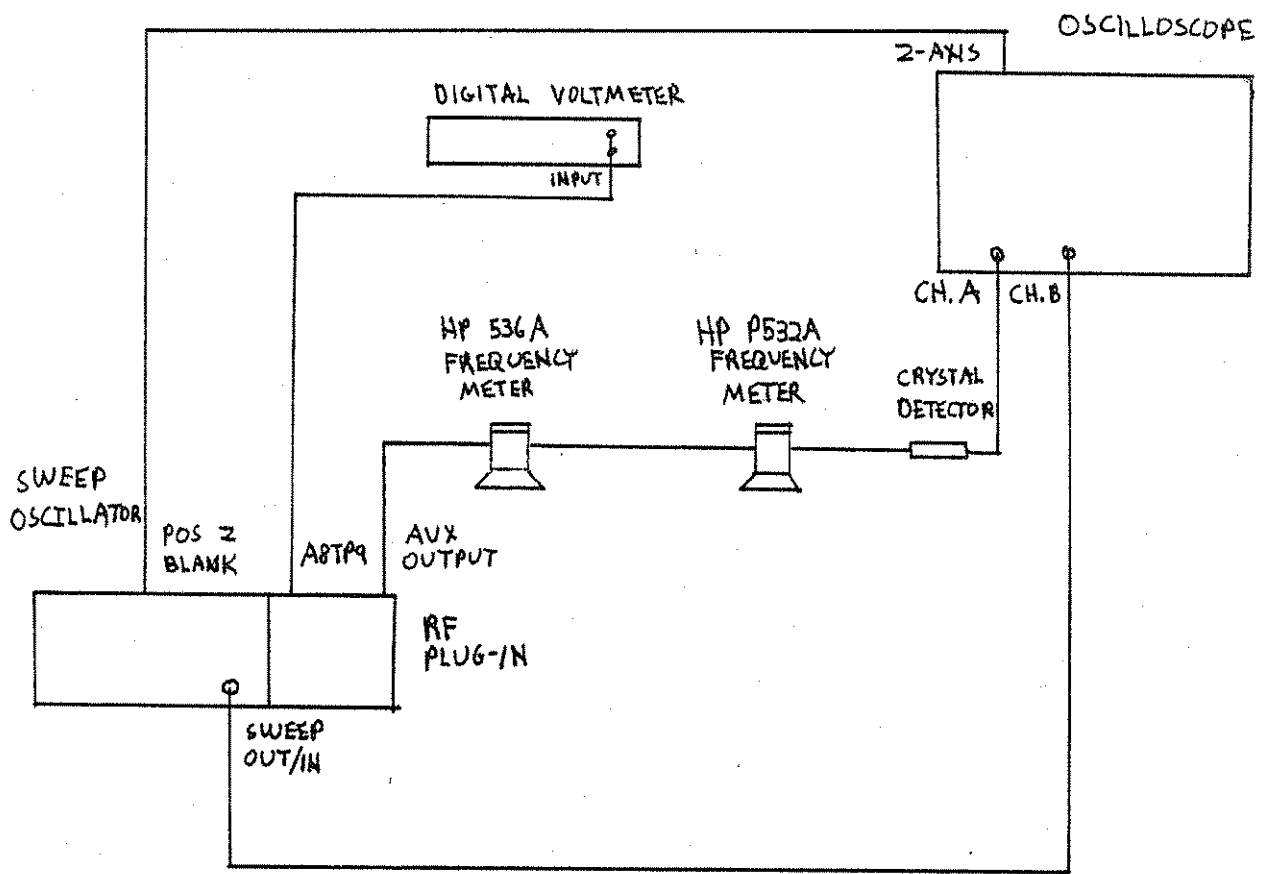

Figure 5-16. YO Delay Compensation Test Setup

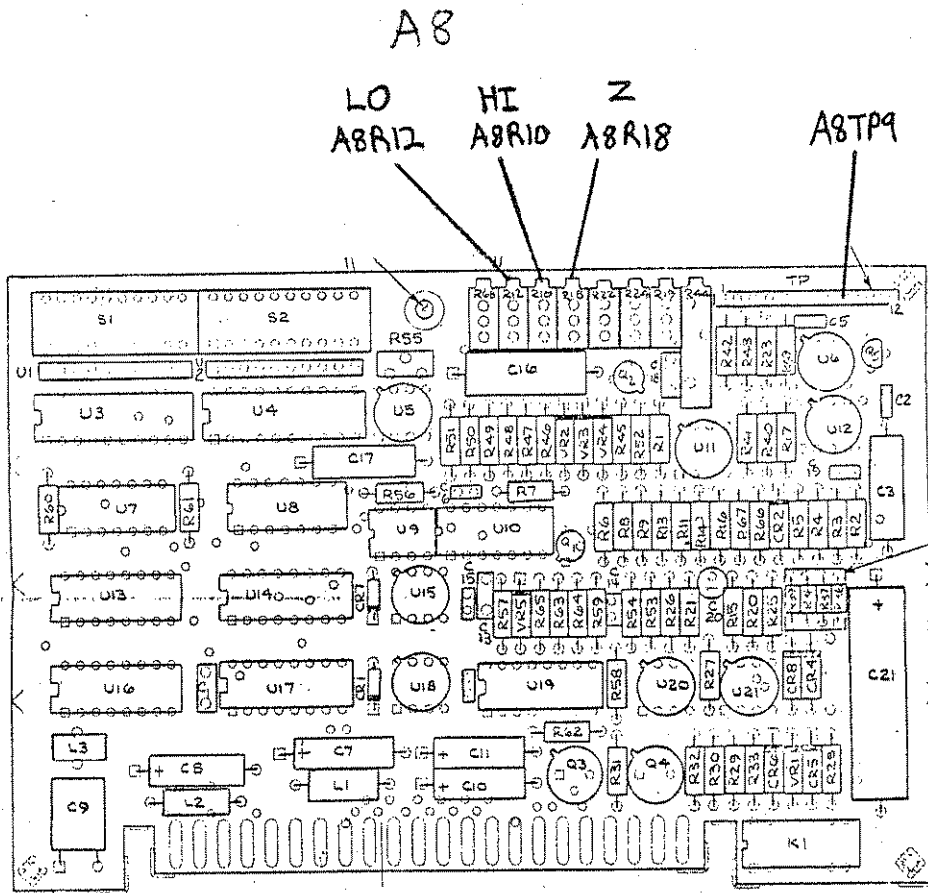

Figure 5-17. Y0 Delay Compensation Adjustment Locations

Note: - Same as manual numbered to 5-13

5-20. SLOW SPEED YTM TO YO TRACKING

REFERENCE:

Performance Test:
Service Sheet: A6 and A7

DESCRIPTION:

EQUIPMENT:

Swept Amplitude Analyzer	HP 8755C
Display Mainframe	HP 180TR
Detector	HP 11664B
10 dB Attenuator	Weinschel Model M9-10
Digital Voltmeter	HP 3455A
Sweep Oscillator	HP 8350A

PROCEDURE:

NOTE

This procedure requires that A3S1 is set to the factory-set position. Refer to Figure 5-6.

1. Connect the equipment as shown in Figure 5-18 with the DVM connected to A6TP3 (with reference to ground). Allow the equipment to warm up for 1 hour.
2. On the 8350A, press [INSTR PRESET START 7 GHz SWEEP TIME 200 mSEC \downarrow MOD]. On the 83592A, press [EXT] leveling. The unlevelled lamp should be lit.
3. Adjust A6R9 (SRD) for a DVM reading of -0.600 ± 0.010 Vdc. Refer to Figure 5-19 for adjustment locations.
4. Preset A6R62 (SB2) and A6R61 (SB3) $1/4$ turn from the full clockwise position.
5. Select 1 dB/Division display resolution on the 8755C and center the display.
6. On the 8350A, press [SHIFT 92] to enable the YTM OFFSET DAC subroutine. Using the 83592A POWER control, peak the power within the first graticule of the display.
7. Enter the number displayed on the 83592A POWER display into A7S1 as shown in Figure 5-21. Refer to Figure 5-20 for the switch location.

8. On the 8350A, press [SHIFT 93] to enable the YTM GAIN DAC subroutine. Using the 83592A POWER control, peak the power within the last graticule of the display.
9. Enter the number displayed on the 83592A POWER display into A7S2 as shown in Figure 5-21. Refer to Figure 5-20 for the switch location.
10. On the 8350A, press [INSTR PRESET] so that the new calibration data will be entered from the current switch settings.
11. On the 8350A, press [STOP 2.4 GHz].
12. Adjust A7R51 (B1 OFS) to maximize the Band 1 displayed trace minimum power points.

+0,21 + ALC ext + 10!

success enter b0 et b1 (agit sur b1)

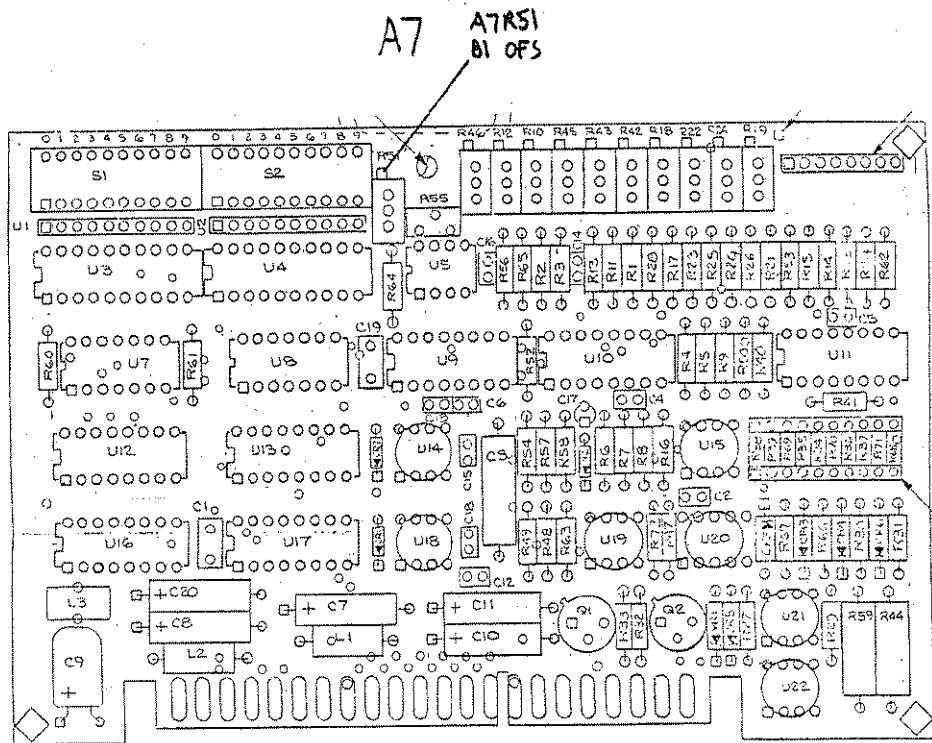
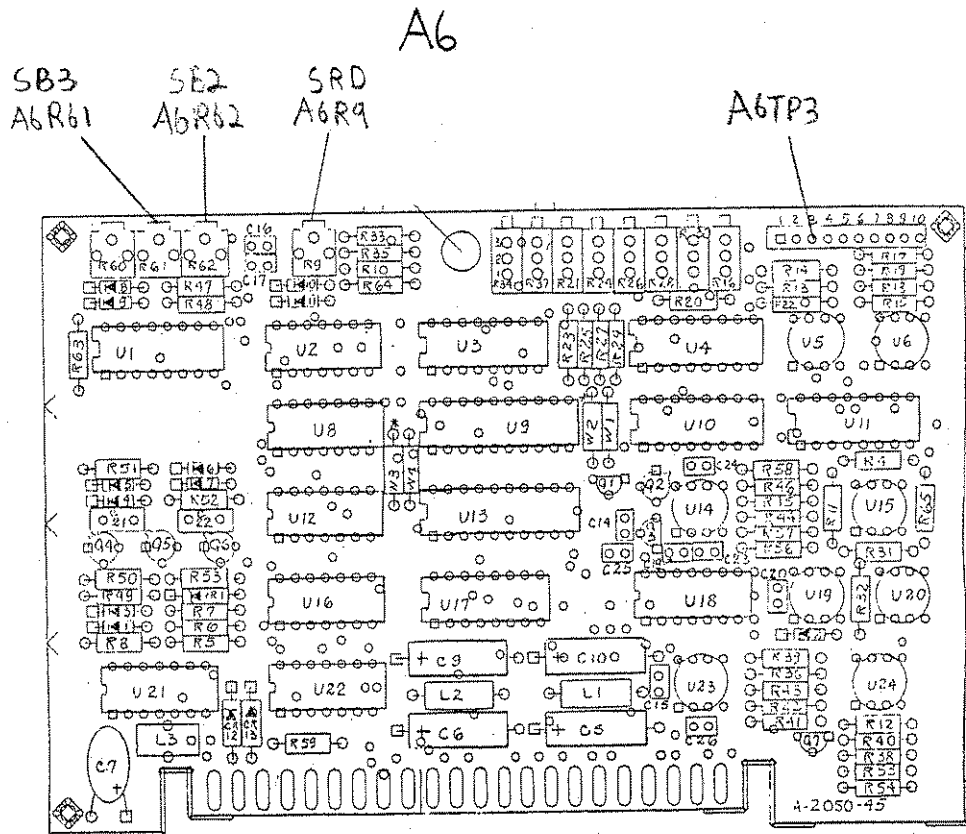

Figure 5-14. Slow Speed YTM to YO Tracking Adjustment Locations

42-387 100 SHEETS 3 SQUARE
 42-389 100 SHEETS 3 SQUARE
 NATIONAL
 MANUFACTURING

HEXADECIMAL	DECIMAL	BINARY
0 thru 9	= 0 thru 9	= 0000 thru 1001
A	= 10	= 1010
b	= 11	= 1011
C	= 12	= 1100
d	= 13	= 1101
E	= 14	= 1110
F	= 15	= 1111

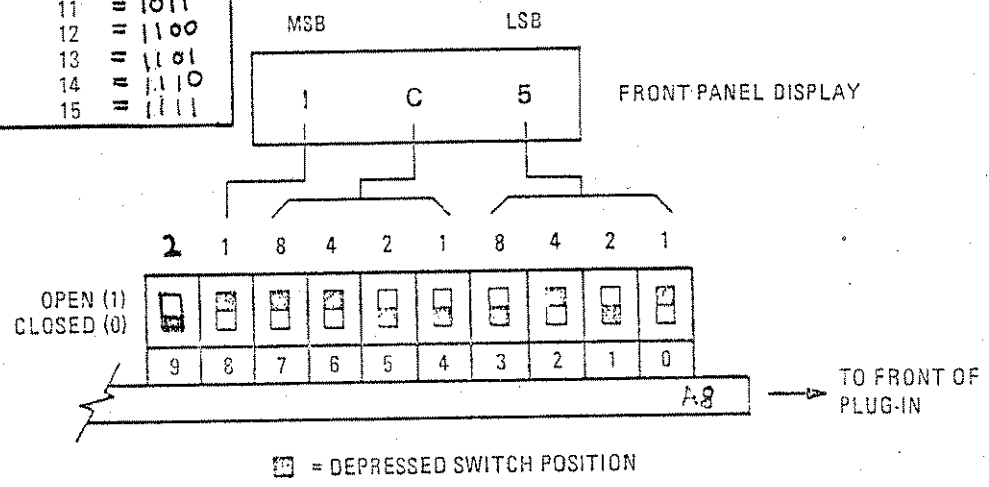

Figure 5-21 YTM to YO Tracking Calibration Switch

5-21. SRD BIAS

REFERENCE:

Performance Test: 8350A Paragraphs 4-17, 4-19
Service Sheet: A4 and A6

DESCRIPTION:

The Low Power SRD Bias is adjusted by inserting a voltage source through a 1 KOhm current limiting resistor into the Mod 1 signal path in place of the A4 ALC board output. With the 83592A at maximum RF output power level, the voltage source is increased (from a starting point of 0.6 Vdc) to set the RF output to a point just above the noise level. At this point, A6R9 (SRD) is adjusted to peak the power at the end of each band. The voltage source is then removed.

The High Power SRD Bias is set by peaking the 8755C displayed trace with A6R62 (SB2) in Band 2 and A6R61 (SB3) in Band 3.

EQUIPMENT:

Swept Amplitude Analyzer	HP 8755C
Display Mainframe	HP 180TR
Detector	HP 11664B
10 dB Attenuator	Weinschel Model M9-10
Power Supply	HP 6213A
Extender Board	08350-60031
Sweep Oscillator	HP 8350A
1 kOhm Resistor	HP 0757-0280

PROCEDURE:

NOTE

Turn 8350A LINE power OFF when removing or installing PC boards.

NOTE

This procedure requires that A381 is set to the factory-set position (refer to Figure 5-6).

Low Power SRD Bias

1. Connect the equipment as shown in Figure 5-22 with the 8755C connected through a 10 dB attenuator to the 8755C.

Connect the 8755C MODULATOR DRIVE output to the 83592A rear panel PULSE IN connector.

2. Allow the equipment to warm up for 1 hour.
3. On the 8350A, press [INSTR PRESET START 7.0 GHz SWEEP TIME 100 mSEC].
4. Set the 8755C display resolution for 10 dB/division and adjust the 8755C VERNIER to set the trace to the top of the screen.
5. Set the 8350A LINE switch to OFF and replace the 83592A A4 ALC Assembly with the extender board. Do not reinsert the A4 board at this point. Connect the Power Supply (set to 0.6 Vdc) to the extender board at A4 P1-pin 19 through the 1 KOhm current limiting resistor (connect the reference to ground).
6. Increase the Power Supply voltage slowly until the displayed trace drops to the point just above the noise level (greater than 45 dB).
7. Adjust A6R9 (SRD) to peak the trace at the end of each band. Refer to Figure 5-23 for adjustment locations.
8. Set the 8350A LINE switch to OFF and replace the A4 ALC assembly.

High Power SRD Bias

9. Set the 8350A LINE power to ON and press [INSTR PRESET START 7.0 GHz SWEEP TIME 100 mSEC].
10. Set the 8755C display resolution to 1 dB/division and adjust A6R62 (SB2) to peak the displayed trace in Band 2.
11. Adjust A6R61 (SB3) to peak the displayed trace in Band 3.

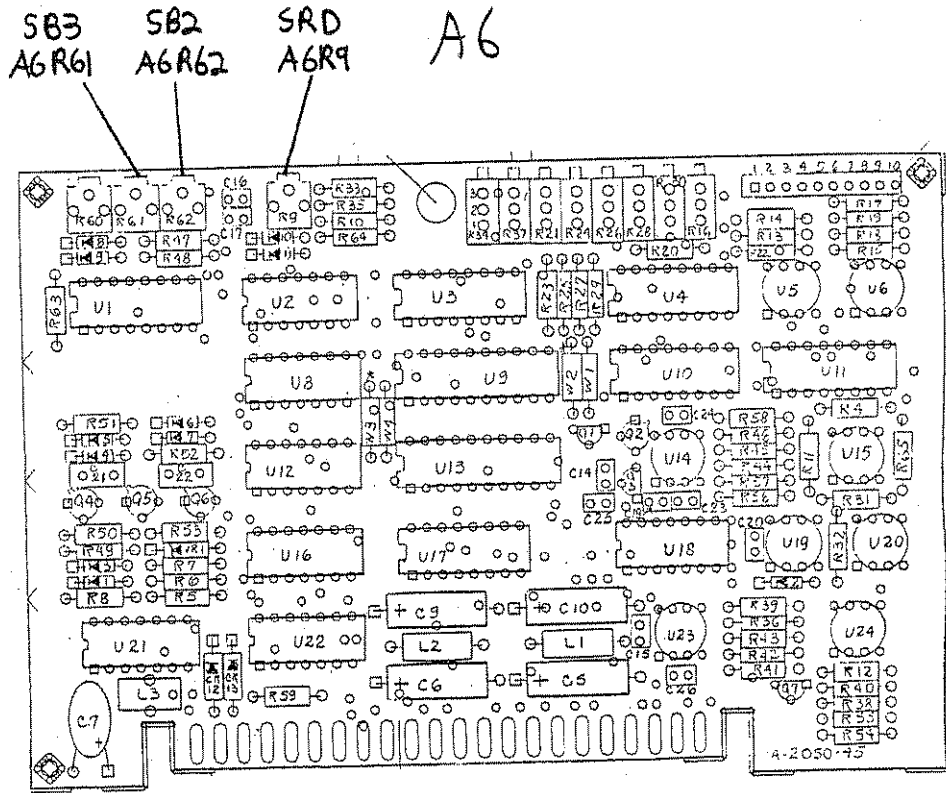

Figure 5-23. SRD Bias Adjustment Locations.

Your Note Step 5-20

5-22. YTM DELAY COMPENSATION

REFERENCE:

Performance Test:
Service Sheet: A7

DESCRIPTION:

EQUIPMENT:

Swept Amplitude Analyzer	HP 8755C
Display Mainframe	HP 180TR
Detector	HP 11664B
10 dB Attenuator	Weinschel Model M9-10
Sweep Oscillator	HP 8350A

PROCEDURE:

NOTE

This procedure requires that A3S1 is set to the factory-set position. Refer to Figure 5-6.

1. Connect the equipment as shown in Figure 5-24. Do not connect the BNC cable between the 8350A rear panel POS Z BLANK and the 180TR AUX C connector yet. Preset A7R45 (SEQ TC) fully counter-clockwise. Refer to Figure 5-25 for adjustment locations. Allow the equipment to warm up for 1 hour.
2. On the 8350A, press [INSTR PRESET] MOD SAVE 1 SWEEP TIME 0.5 SEC SAVE 21.
3. Adjust A7R45 (SEQ TC) for the highest power with the best defined (brightest) bandswitch point between Band 2 and Band 3.
4. Connect a BNC cable from the 8350A rear panel POS Z BLANK connector to the 180TR rear panel AUX C connector.
5. Adjust A7R43 (SEQ LO) for maximum power at the beginning of Band 2.
6. Adjust A7R42 (SEQ HI) for maximum power at the end of Band 3.

7. On the 8350A, iterate between [RECALL 1] and [RECALL 2] while readjusting A7R42 (SEQ HI) and A7R43 (SEQ LO) as necessary to minimize the power level changes.
8. On the 8350A, press [START 7.1 GHz SWEEP TIME 25 mSEC].
9. Adjust A7R55 (RTC COMP) for maximum power in Band 2.
10. Vary the 8350A START FREQUENCY control from 10 MHz to 13 GHz to check for power variations. Readjust A7R42 (SEQ HI), A7R43 (SEQ LO), and A7R55 (RTC COMP) as necessary to minimize any droop in power (particularly near 20 GHz). The worst case droop should not exceed 0.5 dB as the START frequency is varied. If this step cannot be met, repeat the Slow Speed YTM to YO Tracking Adjustments.
11. On the 8350A, press [INSTR PRESET MOD].
12. Repeatedly press [SINGLE SWEEP TRIGGER] while watching the displayed power level. Readjust A7R42 (SEQ HI) and A7R43 (SEQ LO) as necessary to minimize the power level difference between a 25 mSEC single sweep and a 25 mSEC [INTERNAL SWEEP].
13. On the 8350A, press [INSTR PRESET MOD START 6.9 GHz STOP 13.5 GHz].
14. Preset A7R46 (SGL TC) fully counter-clockwise.
15. While continuously changing the [SWEEP TIME] control for a sweep speed from 25 mSEC to 100 mSEC, adjust A7R12 (SGL LO) to maximize power at the low end of Band 2. In the same manner, adjust A7R10 (SGL HI) to maximize the power at the high end of Band 2. Then adjust A7R46 (SGL TC) to maximize the power at the very start of the band.
16. On the 8350A, press [START 13.4 GHz STOP 20 GHz]. Vary the sweep speed as in step 15 and note any drop in power. If the change is greater than 0.5 dB, make slight adjustments to A7R10 (SGL HI) and A7R12 (SGL LO). If it is necessary to adjust A7R10 (SGL HI) and A7R12 (SGL LO), repeat step 15 and 16 until the power variation while adjusting sweep time is less than 0.5 dB.

A7

RTC COMP SGL TC SGL LO SGL HI SEQ TC SEQ LO SEQ HI
A7R55 A7R46 A7R12 A7R10 A7R45 A7R43 A7R42

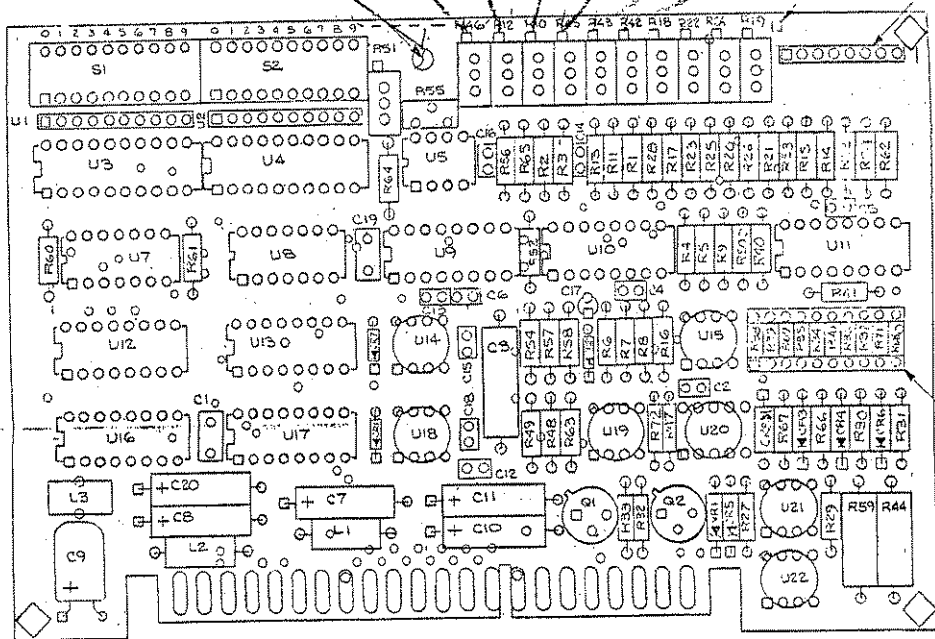

Figure 5-25. YTM Delay Compensation Adjustment Locations

5-23. BAND OVERLAP

REFERENCE:

Performance Test: 8350A Paragraph 4-13
Service Sheet: A6

DESCRIPTION:

EQUIPMENT:

Oscilloscope	HP 1740A
Frequency Meter (0.96-4.2 GHz)	HP 536A
Frequency Meter (3.7-12.4 GHz)	HP 537A
Frequency Meter (12.4-18 GHz)	HP P532A
10 dB Attenuator	Weinschel Model M9-10
Detector	HP 8473C
Sweep Oscillator	HP 8350A

PROCEDURE:

NOTE

This procedure requires that A3S1 be set to the factory-set position. Refer to Figure 5-6.

1. Connect the equipment as shown in Figure 5-26. Allow the equipment to warm up for 1 hour.
2. On the 8350A, press [INSTR PRESET CF 2.4 GHz Δ F 250 MHz].
3. Set the oscilloscope for A versus B display mode to display amplitude versus frequency. Center the display on screen.
4. Set the 536A Frequency Meter to 2.4 GHz.
5. Center the bandswitch point on the display using the 8350A FREQUENCY control.
6. Adjust the Frequency Meter to put the left half of the pip on the left side of the switch point.
7. Adjust A6R28 (B1) to bring the right side pip over to the switch point so that the right half of this pip mates with the left half of the other as shown in Figure 5-28. Refer to Figure 5-27 for the adjustment location. The pip should be undisturbed as it moves through the bandswitch point.

8. Set the 537A Frequency Meter to 7.0 GHz.
9. On the 8350A, press [CF 7 GHz].
10. Repeat steps 5 through 7 but, this time, adjust A6R26 (B2) in step 7.
11. Set the P532A Frequency Meter to 13.5 GHz.
12. On the 8350A, press [CF 13.5 GHz].
13. Repeat steps 5 through 7 but, this time, adjust A6R24 (B3) in step 7.

15000 50 SQUARE WAVE
43724 50 SQUARE WAVE
43725 200 SQUARE WAVE
43726 200 SQUARE WAVE
43727 200 SQUARE WAVE
43728 200 SQUARE WAVE
43729 200 SQUARE WAVE
43730 200 SQUARE WAVE
43731 200 SQUARE WAVE
43732 200 SQUARE WAVE
43733 200 SQUARE WAVE
43734 200 SQUARE WAVE
43735 200 SQUARE WAVE
43736 200 SQUARE WAVE
43737 200 SQUARE WAVE
43738 200 SQUARE WAVE
43739 200 SQUARE WAVE
43740 200 SQUARE WAVE
43741 200 SQUARE WAVE
43742 200 SQUARE WAVE
43743 200 SQUARE WAVE
43744 200 SQUARE WAVE
43745 200 SQUARE WAVE
43746 200 SQUARE WAVE
43747 200 SQUARE WAVE
43748 200 SQUARE WAVE
43749 200 SQUARE WAVE
43750 200 SQUARE WAVE
43751 200 SQUARE WAVE
43752 200 SQUARE WAVE
43753 200 SQUARE WAVE
43754 200 SQUARE WAVE
43755 200 SQUARE WAVE
43756 200 SQUARE WAVE
43757 200 SQUARE WAVE
43758 200 SQUARE WAVE
43759 200 SQUARE WAVE
43760 200 SQUARE WAVE
43761 200 SQUARE WAVE
43762 200 SQUARE WAVE
43763 200 SQUARE WAVE
43764 200 SQUARE WAVE
43765 200 SQUARE WAVE
43766 200 SQUARE WAVE
43767 200 SQUARE WAVE
43768 200 SQUARE WAVE
43769 200 SQUARE WAVE
43770 200 SQUARE WAVE
43771 200 SQUARE WAVE
43772 200 SQUARE WAVE
43773 200 SQUARE WAVE
43774 200 SQUARE WAVE
43775 200 SQUARE WAVE
43776 200 SQUARE WAVE
43777 200 SQUARE WAVE
43778 200 SQUARE WAVE
43779 200 SQUARE WAVE
43780 200 SQUARE WAVE
43781 200 SQUARE WAVE
43782 200 SQUARE WAVE
43783 200 SQUARE WAVE
43784 200 SQUARE WAVE
43785 200 SQUARE WAVE
43786 200 SQUARE WAVE
43787 200 SQUARE WAVE
43788 200 SQUARE WAVE
43789 200 SQUARE WAVE
43790 200 SQUARE WAVE
43791 200 SQUARE WAVE
43792 200 SQUARE WAVE
43793 200 SQUARE WAVE
43794 200 SQUARE WAVE
43795 200 SQUARE WAVE
43796 200 SQUARE WAVE
43797 200 SQUARE WAVE
43798 200 SQUARE WAVE
43799 200 SQUARE WAVE
43800 200 SQUARE WAVE
43801 200 SQUARE WAVE
43802 200 SQUARE WAVE
43803 200 SQUARE WAVE
43804 200 SQUARE WAVE
43805 200 SQUARE WAVE
43806 200 SQUARE WAVE
43807 200 SQUARE WAVE
43808 200 SQUARE WAVE
43809 200 SQUARE WAVE
43810 200 SQUARE WAVE
43811 200 SQUARE WAVE
43812 200 SQUARE WAVE
43813 200 SQUARE WAVE
43814 200 SQUARE WAVE
43815 200 SQUARE WAVE
43816 200 SQUARE WAVE
43817 200 SQUARE WAVE
43818 200 SQUARE WAVE
43819 200 SQUARE WAVE
43820 200 SQUARE WAVE
43821 200 SQUARE WAVE
43822 200 SQUARE WAVE
43823 200 SQUARE WAVE
43824 200 SQUARE WAVE
43825 200 SQUARE WAVE
43826 200 SQUARE WAVE
43827 200 SQUARE WAVE
43828 200 SQUARE WAVE
43829 200 SQUARE WAVE
43830 200 SQUARE WAVE
43831 200 SQUARE WAVE
43832 200 SQUARE WAVE
43833 200 SQUARE WAVE
43834 200 SQUARE WAVE
43835 200 SQUARE WAVE
43836 200 SQUARE WAVE
43837 200 SQUARE WAVE
43838 200 SQUARE WAVE
43839 200 SQUARE WAVE
43840 200 SQUARE WAVE
43841 200 SQUARE WAVE
43842 200 SQUARE WAVE
43843 200 SQUARE WAVE
43844 200 SQUARE WAVE
43845 200 SQUARE WAVE
43846 200 SQUARE WAVE
43847 200 SQUARE WAVE
43848 200 SQUARE WAVE
43849 200 SQUARE WAVE
43850 200 SQUARE WAVE
43851 200 SQUARE WAVE
43852 200 SQUARE WAVE
43853 200 SQUARE WAVE
43854 200 SQUARE WAVE
43855 200 SQUARE WAVE
43856 200 SQUARE WAVE
43857 200 SQUARE WAVE
43858 200 SQUARE WAVE
43859 200 SQUARE WAVE
43860 200 SQUARE WAVE
43861 200 SQUARE WAVE
43862 200 SQUARE WAVE
43863 200 SQUARE WAVE
43864 200 SQUARE WAVE
43865 200 SQUARE WAVE
43866 200 SQUARE WAVE
43867 200 SQUARE WAVE
43868 200 SQUARE WAVE
43869 200 SQUARE WAVE
43870 200 SQUARE WAVE
43871 200 SQUARE WAVE
43872 200 SQUARE WAVE
43873 200 SQUARE WAVE
43874 200 SQUARE WAVE
43875 200 SQUARE WAVE
43876 200 SQUARE WAVE
43877 200 SQUARE WAVE
43878 200 SQUARE WAVE
43879 200 SQUARE WAVE
43880 200 SQUARE WAVE
43881 200 SQUARE WAVE
43882 200 SQUARE WAVE
43883 200 SQUARE WAVE
43884 200 SQUARE WAVE
43885 200 SQUARE WAVE
43886 200 SQUARE WAVE
43887 200 SQUARE WAVE
43888 200 SQUARE WAVE
43889 200 SQUARE WAVE
43890 200 SQUARE WAVE
43891 200 SQUARE WAVE
43892 200 SQUARE WAVE
43893 200 SQUARE WAVE
43894 200 SQUARE WAVE
43895 200 SQUARE WAVE
43896 200 SQUARE WAVE
43897 200 SQUARE WAVE
43898 200 SQUARE WAVE
43899 200 SQUARE WAVE
43900 200 SQUARE WAVE
43901 200 SQUARE WAVE
43902 200 SQUARE WAVE
43903 200 SQUARE WAVE
43904 200 SQUARE WAVE
43905 200 SQUARE WAVE
43906 200 SQUARE WAVE
43907 200 SQUARE WAVE
43908 200 SQUARE WAVE
43909 200 SQUARE WAVE
43910 200 SQUARE WAVE
43911 200 SQUARE WAVE
43912 200 SQUARE WAVE
43913 200 SQUARE WAVE
43914 200 SQUARE WAVE
43915 200 SQUARE WAVE
43916 200 SQUARE WAVE
43917 200 SQUARE WAVE
43918 200 SQUARE WAVE
43919 200 SQUARE WAVE
43920 200 SQUARE WAVE
43921 200 SQUARE WAVE
43922 200 SQUARE WAVE
43923 200 SQUARE WAVE
43924 200 SQUARE WAVE
43925 200 SQUARE WAVE
43926 200 SQUARE WAVE
43927 200 SQUARE WAVE
43928 200 SQUARE WAVE
43929 200 SQUARE WAVE
43930 200 SQUARE WAVE
43931 200 SQUARE WAVE
43932 200 SQUARE WAVE
43933 200 SQUARE WAVE
43934 200 SQUARE WAVE
43935 200 SQUARE WAVE
43936 200 SQUARE WAVE
43937 200 SQUARE WAVE
43938 200 SQUARE WAVE
43939 200 SQUARE WAVE
43940 200 SQUARE WAVE
43941 200 SQUARE WAVE
43942 200 SQUARE WAVE
43943 200 SQUARE WAVE
43944 200 SQUARE WAVE
43945 200 SQUARE WAVE
43946 200 SQUARE WAVE
43947 200 SQUARE WAVE
43948 200 SQUARE WAVE
43949 200 SQUARE WAVE
43950 200 SQUARE WAVE
43951 200 SQUARE WAVE
43952 200 SQUARE WAVE
43953 200 SQUARE WAVE
43954 200 SQUARE WAVE
43955 200 SQUARE WAVE
43956 200 SQUARE WAVE
43957 200 SQUARE WAVE
43958 200 SQUARE WAVE
43959 200 SQUARE WAVE
43960 200 SQUARE WAVE
43961 200 SQUARE WAVE
43962 200 SQUARE WAVE
43963 200 SQUARE WAVE
43964 200 SQUARE WAVE
43965 200 SQUARE WAVE
43966 200 SQUARE WAVE
43967 200 SQUARE WAVE
43968 200 SQUARE WAVE
43969 200 SQUARE WAVE
43970 200 SQUARE WAVE
43971 200 SQUARE WAVE
43972 200 SQUARE WAVE
43973 200 SQUARE WAVE
43974 200 SQUARE WAVE
43975 200 SQUARE WAVE
43976 200 SQUARE WAVE
43977 200 SQUARE WAVE
43978 200 SQUARE WAVE
43979 200 SQUARE WAVE
43980 200 SQUARE WAVE
43981 200 SQUARE WAVE
43982 200 SQUARE WAVE
43983 200 SQUARE WAVE
43984 200 SQUARE WAVE
43985 200 SQUARE WAVE
43986 200 SQUARE WAVE
43987 200 SQUARE WAVE
43988 200 SQUARE WAVE
43989 200 SQUARE WAVE
43990 200 SQUARE WAVE
43991 200 SQUARE WAVE
43992 200 SQUARE WAVE
43993 200 SQUARE WAVE
43994 200 SQUARE WAVE
43995 200 SQUARE WAVE
43996 200 SQUARE WAVE
43997 200 SQUARE WAVE
43998 200 SQUARE WAVE
43999 200 SQUARE WAVE
44000 200 SQUARE WAVE

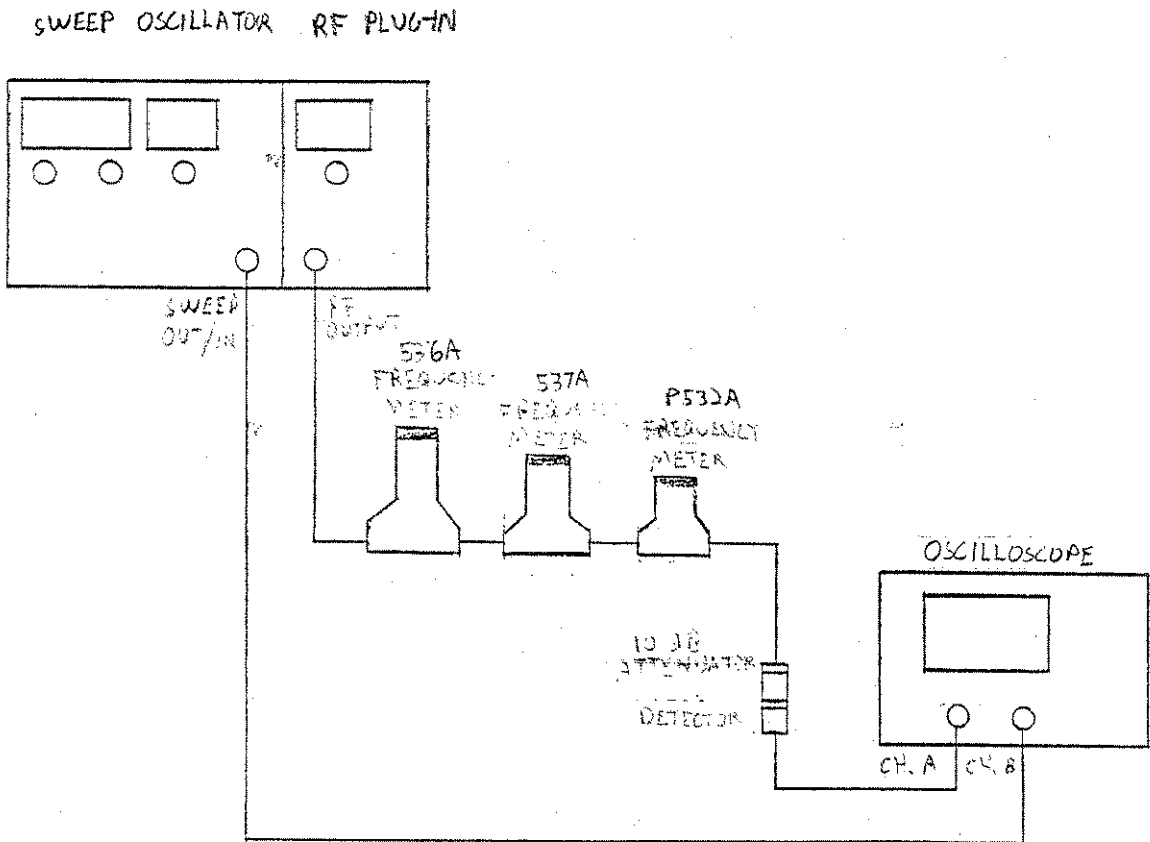

Figure B-26. Band Overlap Adjustment Test Setup

A6

B3
A6R24

B2
A6R26

B1
A6R28

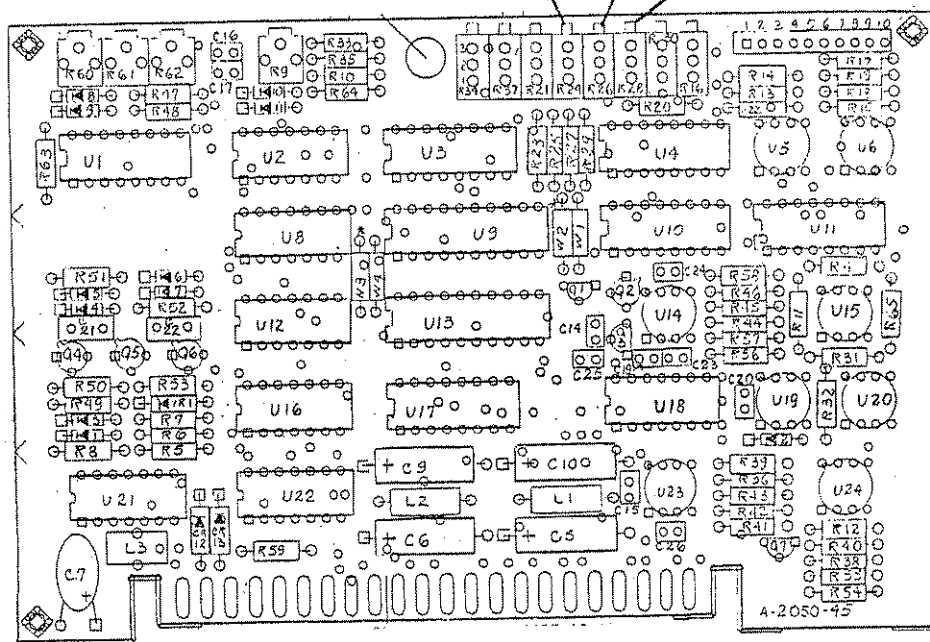

Figure 5-27. Band Overlap Adjustments Location

5-24. FREQUENCY REFERENCE 1V/GHz OUTPUT

REFERENCE:

Performance Test: 8350A Paragraph 4-13.
Service Sheet: A2

DESCRIPTION:

The frequency reference rear panel output is adjusted for 1 Volt per GHz output. Example: 1 GHz = 1 Volt; 2 GHz = 2 Volts, etc.

EQUIPMENT:

Digital Voltmeter	HP 3455A
Sweep Oscillator	HP 8350A

PROCEDURE:

NOTE

Frequency accuracy must be adjusted accurately (Paragraph 5-17) before adjusting Frequency Reference 1 V/GHz output.

1. Connect the equipment with the DVM connected to the rear panel 1V/GHz Frequency Reference connector, J4. Allow the equipment to warm up for 1 hour.

Band 0

2. Adjust A2R6 (BAND 0 OFFSET) to the center of its mechanical range. Refer to Figure 5-24 for the adjustment location.
3. On the 8350A, press [CW 10 MHz].
4. Adjust A2R6 (BAND 0 OFFSET) for a DVM reading of 0.010 ± 0.005 Vdc.
5. On the 8350A, press [CW 2 GHz].
6. Adjust A2R23 (BAND 0 GAIN) for a DVM reading of 2.000 ± 0.005 Vdc.
7. Repeat steps 2 through 6 until there is no change.

Bands 1 through 3

8. Adjust A2R4 (OFFSET) to the center of its mechanical range.

9. On the 8350A, press [CW 3 GHz].
10. Adjust A2R4 (OFFSET) for a DVM reading of 3.000 ± 0.005 Vdc.
11. On the 8350A, press [CW 15 GHz].
12. Adjust A2R1 (GAIN) for a DVM reading of 15.000 ± 0.005 Vdc.
13. Repeat steps 8 through 12 until there is no change.

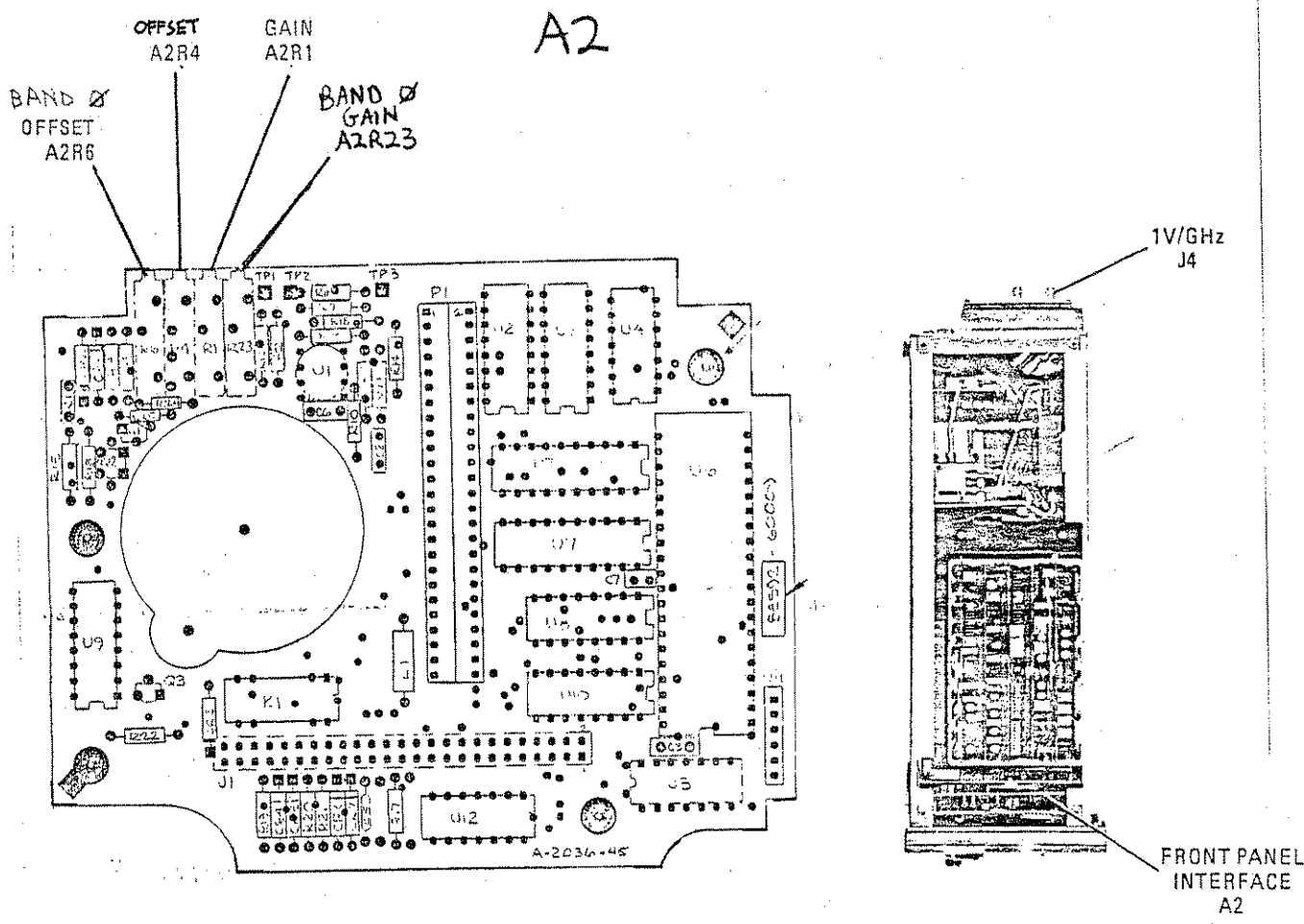

Figure 5-29. Frequency Reference Adjustments Location

5-25. ALC ADJUSTMENT

NOTE

Complete adjustment of the leveling loop requires several procedures to be performed in the order prescribed, from Paragraph 5-25 through 5-27. Deviation from this routine may cause improper leveling and/or power variation problems.

REFERENCE:

Performance Test: 8350A Paragraph 4-14.
Service Sheet: A4

DESCRIPTION:

Adjustments compensate for DC offsets in the detected RF path and the Main ALC Amplifier. Power is roughly calibrated and low band flatness is optimized.

EQUIPMENT:

Digital Voltmeter	HP 3455A
Power Meter	HP 436A
Thermistor Mount	HP 8485A
Swept Amplitude Analyzer	HP 8755C
Display Mainframe	HP 180TR
Detector	HP 11664B
Extender Board	HP 08350-60031
10 dB Attenuator	Weinschel Model M9-10
Sweep Oscillator	HP 8350A

PROCEDURE:

NOTE

Turn AC power OFF when removing or installing PC boards.

NOTE

This procedure assumes that A3S1 is set to the factory-set position (Table 5-6).

and at the 8350A Sweep Oscillator, 27.8
kHz square wave modulation is selected.

1. Remove A5 FM Driver board. Place A4 assembly on an extender board. Sweep the full range of the plug-in at any leveled power. Preset the following adjustments as indicated:

A4R47 (OFS 1)	Midrange
A4R56 (OFS 2)	Midrange
A4R59 (OFS 3)	Midrange
A4R67 (OFS 4)	Midrange
A4R11 (GAIN)	Midrange
A4R2 (0 HI)	Fully CW
A4R3 (1 HI)	Fully CW
A4R4 (BIAS)	Midrange
A4R1 (SLP)	Midrange

2. Float the ground on the digital voltmeter and measure the voltage between A4TP12 and A4TP14. Refer to Figure 5-31 for adjustment locations. Adjust A4R47 (OFS 1) for 0.000 ± 0.001 Vdc.
3. Attach a jumper from A4TP11 to ground. Connect the DVM to A4TP5 (reference to ground) and adjust A4R56 (OFS 2) for a DVM reading of 0.000 ± 0.001 Vdc. Remove the jumper.
4. Connect the DVM between A4TP12 and A4TP15. Adjust A4R59 (OFS 3) for a DVM reading of 0.000 ± 0.001 Vdc.
5. On the 8350A, press [CW] and ensure that the power is leveled (83592A UNLEVELED light off). Connect the DVM to A4TP7 and adjust A4R67 (OFS 4) for a DVM reading of 0.000 ± 0.001 Vdc.
6. On the 8350A, press [CW 50 MHz]. Turn off the 83592A [RF] power. Connect the DVM to A4TP10 and adjust A4R4 (BIAS) for a DVM reading of 0.000 ± 0.001 Vdc. Turn on the 83592A [RF] power.
7. Set the 8350A [LINE] power to OFF. Remove the A4 assembly from the extender board and reinsert the A4 assembly directly into the instrument. Set the 8350A [LINE] power to ON and press [CW 50 MHz]. Connect the power meter to the 83592A RF OUTPUT.
8. Set the 83592A for a POWER reading of -3 dBm. Adjust A4R6 (0 LD) for an RF OUTPUT power at the 83592A connector of -3 ± 0.1 dBm.
9. Set the 83592A for a POWER reading of +7 dBm. Adjust A4R7

- (0 MD) for an RF OUTPUT power at the 83592A connector of $+7 \pm 0.1$ dBm.
10. Iterate between steps 8 and 9 until both low and midpower ranges are calibrated and no readjustment is necessary.
 11. Set the 83592A for a POWER reading of +10 dBm. Adjust A4R2 (0 HI) for an RF OUTPUT power at the 83592A connector of $+10 \pm 0.1$ dBm.
 12. Disconnect the power meter and monitor the RF output with the 8755C. Press 8350A [INSTR PRESET] to sweep the full range of the plug-in. Select 8350A [\square MOD] for compatibility with the 8755C. Set the 83592A for a POWER reading of -3 dBm. Select [RF BLANK]. Press [SAVE 1].
 13. Adjust A4R1 (SLP) for best overall flatness from 10 MHz to 2.2 GHz as observed on the 8755C.
 14. Adjust A4R5 (1 LO) for best continuity at the bandswitch point at 2.2 GHz.
 15. Set the 83592A for a POWER reading of +7 dBm. On the 8350A, press [SAVE 2]. Adjust A4R8 (1 MD) for best continuity at the bandswitch point.
 16. Set the 83592A for a POWER reading of +10 dBm. On the 8350A, press [SAVE 3]. Adjust A4R3 (1 HI) for best trace continuity at the bandswitch point.
 17. Iterate between steps 14, 15, and 16 using RECALL 1, 2, and 3 until trace continuity at all three power settings is achieved.
 18. Reinstall the A5 FM board assembly.

5-26. ALC INTERNAL LEVELED FLATNESS

NOTE

Complete adjustment of the leveling loop requires several procedures to be performed in the order prescribed, from Paragraph 5-25 through 5-27. Deviation from this routine may cause improper leveling and/or power variation problems.

REFERENCE:

Performance Test: 8350A Paragraph 4-14.
Service Sheet: A5

DESCRIPTION:

Four parallel circuits on the A5 assembly provide adjustments for ALC flatness. BP1 through BP4 and SL1 through SL4 determine the slope of the flatness compensation signal input to the A4 ALC assembly. Breakpoint potentiometers (BP1-4) determine the frequency at which the corresponding slope potentiometers (SL1-4) begin to affect power output leveling.

EQUIPMENT:

Swept Amplitude Analyzer	HP 8755C
Display Mainframe	HP 180TR
Detector	HP 11664B
10 dB Attenuator	Weinschel Model M9-10
Sweep Oscillator	HP 8350A

PROCEDURE:

NOTE

This procedure requires that A3S1 is set to the factory-set position (Table 5-6), and at the 8350A Sweep Oscillator, 27.8 kHz square wave modulation is selected.

1. Connect equipment as shown in Figure 5-32 with the 8755C monitoring the RF output through the 10 dB attenuator. On the 8350A, press [INSTR PRESET] MDD1. Allow the equipment to warm up for 1 hour.

NOTE

The following step negates any power variation compensation by effectively removing the ALC Power Variation Adjustments from the leveling circuitry. This step may be omitted if RF power variation approaches specified limits.

2. Adjust all breakpoint potentiometers fully clockwise to effectively remove the circuit from the leveling loop (ASR34 (BP1), ASR36 (BP2), ASR38 (BP3), and ASR40 (BP4)). Refer to Figure 5-33 for adjustment locations.
3. Adjust ASR48 (SLP) for best overall flatness.
4. Set breakpoint adjustments ASR34, ASR36, ASR38, and ASR40 (BP1-4) and slope adjustments ASR41 through ASR44 (SL1-4) for best overall flatness. (BP1 and SL1 are interdependent adjustments, as are BP2 and SL2, etc.). The breakpoint potentiometers determine the frequency at which the slope adjustments will take effect. This is observed as a pivot point on the CRT trace.

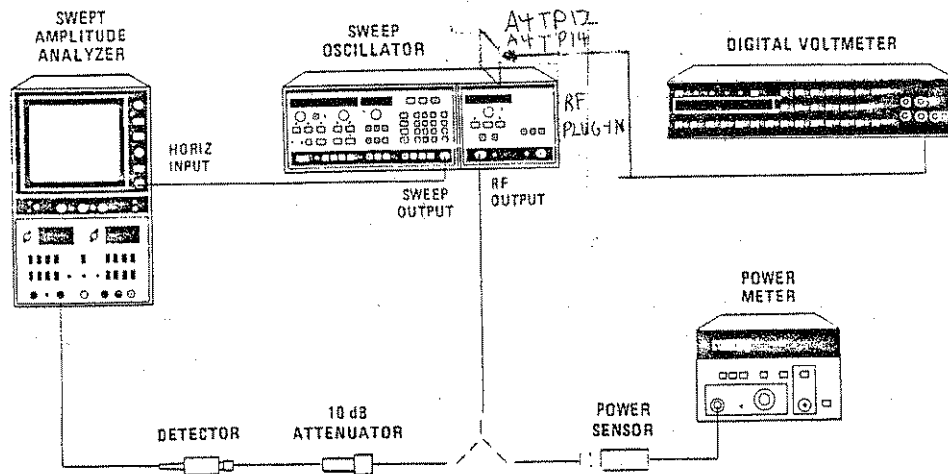

Figure 5-30. ALC Adjustment Test Setup

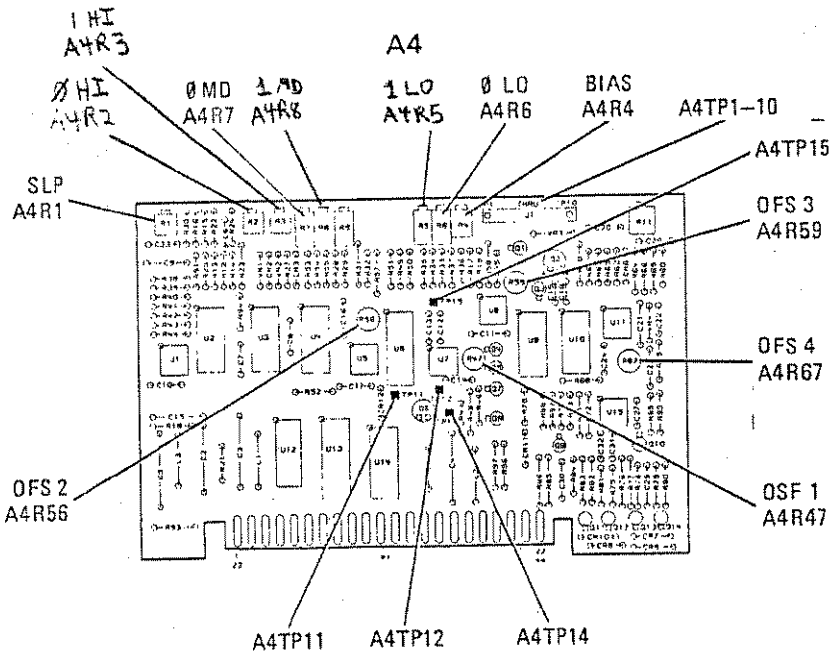

Figure 5-31. ALC Adjustments Location

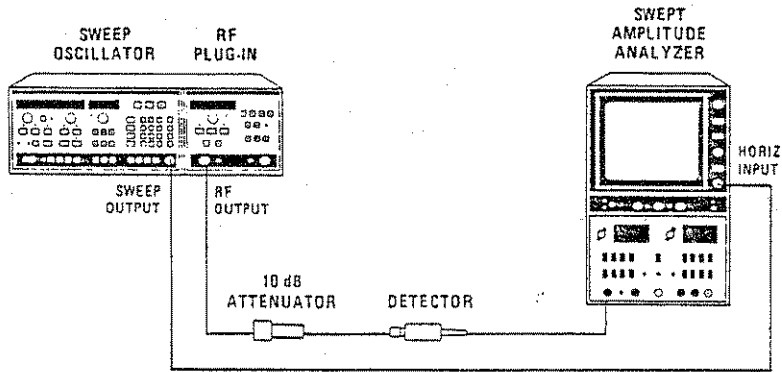

Figure 5-32. Internal Leveling Adjustment Test Setup

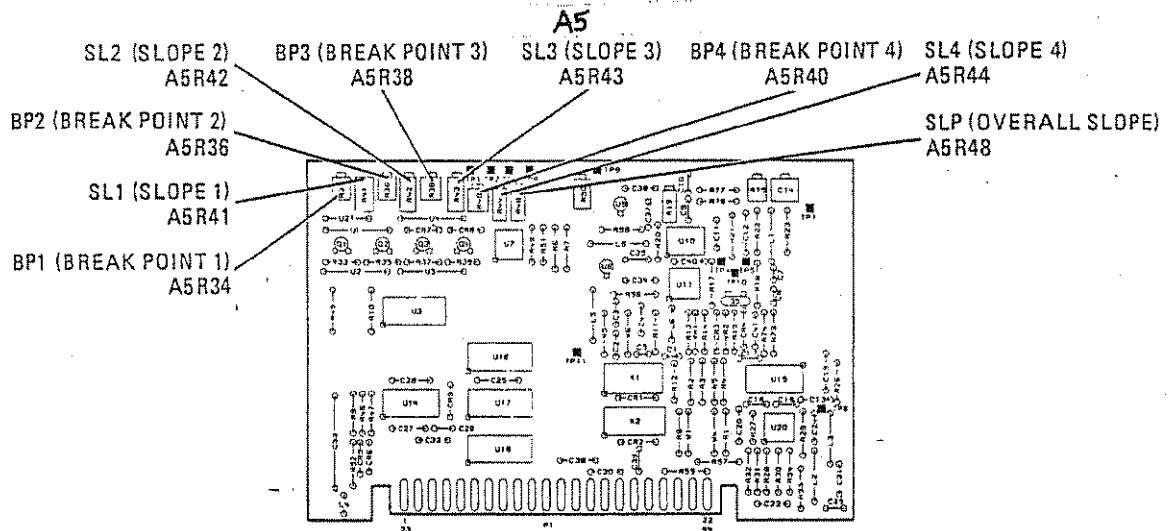

Figure 5-33. Internal Leveling Adjustments Location

5-27. ALC GAIN ADJUSTMENT

NOTE

Complete adjustment of the leveling loop requires several procedures to be performed in the order prescribed, from paragraph 5-25 to 5-27. Deviation from this routine may cause improper leveling and/or power variation problems.

REFERENCE:

8350A Paragraph 4-14, 4-19, and 4-21
Service Sheet: A4

DESCRIPTION:

A4R11 (GAIN) in the input leg of A4U11 adjusts the gain of the Main ALC Amplifier on the A4 assembly. A4R11 (GAIN) is adjusted for maximum possible gain without producing oscillations.

EQUIPMENT:

Sweep Oscillator	HP 8350A
Oscilloscope	HP 1740A
Crystal Detector	HP 8473C
Power Meter	HP 432A
Thermistor Mount (0.01 to 18 GHz)	HP 8748B
Thermistor Mount (18 to 26.5 GHz)	HP K486A
Waveguide to APC 3.5(f) Adapter (18 to 26.5 GHz)	HP K281C
10 dB Attenuator	Weinschel Model M9-10
Power Splitter	Weinschel Model 1579A
Type N(m) to SMA(f) Adapter	HP 1250-1250

PROCEDURE:

NOTE

This procedure requires that A3S1 is set to the factory-set position.

1. Connect the equipment as shown in Figure 5-34 with the 8478B Thermistor Mount connected to the Power Splitter. Preset A4R11 (GAIN) fully clockwise. Refer to Figure 5-35 for the adjustment location. Allow the equipment to warm up for 1 hour.
2. On the 8350A, press [INSTR PRESET STOP 18.0 GHz].

3. On the Oscilloscope, select A versus B mode to display a plot of amplitude versus frequency. Set the Channel A Vertical Sensitivity for 0.01 volts/division and ac coupling. Set the Channel B Vertical Sensitivity for 1 volt/division and dc coupling. Adjust the horizontal position and vertical position controls for a stable display at mid screen.
4. Set the Power Meter RANGE switch to +5 dBm. Note the Power Meter needle position.
5. On the 83592A, press [MTR] ALC mode.
6. On the 8350A, press [SWEEP TIME 100 SEC].
7. If necessary, adjust the output power with the 83592A front panel POWER control to position the Power Meter needle to the same reading noted in step 4. Then, decrease the Power Meter range switch by three 5 dB steps to -10 dB. This attenuates the output power by 15 dB which causes the 83592A output power to be near the low end of its power range (approximately -5 dBm).
8. Observe the trace dot as it sweeps across the CRT. Adjust A4R11 (GAIN) clockwise, increasing the gain of the ALC loop, until the trace dot begins to oscillate. Then, reduce the gain slightly to eliminate the oscillations when a sharp trace dot is obtained.
9. Set the 83592A to maximum leveled RF Output power by returning the Power Meter range switch to the +5 dB position. Observe the trace through the entire sweep to ensure that no oscillations occur. If oscillations do occur, reduce the gain slightly by turning A4R11 (GAIN) counterclockwise.
10. On the 8350A, press [INSTR PRESET STOP 18.0 GHz] to set the 83592A to INTERNAL leveling.
11. Adjust the Oscilloscope Channel A vertical sensitivity to obtain the internally leveled sweep trace at center screen. If oscillations are present, further reduce the loop gain by adjusting A4R11 (GAIN) counterclockwise.
12. Reduce the 83592A RF Output power by rotating the 83592A POWER control until the 83592A POWER display reads -5 dBm. Observe a full sweep. If oscillations occur, reduce the gain further by adjusting A4R11 (GAIN) counterclockwise.

13. Reconnect the equipment with the K486A Thermistor Mount and the Adapter connected to the Power Splitter as shown in Figure 5-33.
14. On the 8350A, press [INSTR PRESET START 17.5 GHz STOP 20 GHz].
15. On the Oscilloscope, adjust the horizontal position and vertical position controls for a stable display at mid screen.
16. Set the Power Meter RANGE switch to +5 dBm. Note the Power Meter needle position.
17. On the 83592A, press [MTR] ALC mode.
18. On the 8350A, press [SWEEP TIME 100 SEC].
19. If necessary, adjust the output power with the 83592A front panel POWER control to position the Power Meter needle to the same reading noted in step 16. Then, decrease the Power Meter range switch by three 5 dB steps to -10 dB. This attenuates the output power by 15 dB which causes the 83592A output power to be near the low end of its power range (approximately -5 dBm).
20. Observe the trace dot as it sweeps across the CRT. If oscillations occur, reduce the gain by adjusting A4R11 (GAIN) counterclockwise.
21. Set the 83592A to maximum leveled RF Output power by returning the Power Meter range switch to the +5 dB position. Observe the trace through the entire sweep to ensure that no oscillations occur with the 83592A at maximum power. If oscillations do occur, further reduce the gain slightly by turning A4R11 (GAIN) counterclockwise.
22. On the 8350A, press [INSTR PRESET START 17.5 GHz] to set the 83592A to INTERNAL leveling.
23. Adjust the Oscilloscope Channel A vertical sensitivity to obtain the internally leveled sweep trace at center screen. If oscillations are present, further reduce the loop gain by adjusting A4R11 (GAIN) counterclockwise.
24. Reduce the 83592A RF Output power by rotating the 83592A POWER control until the 83592A POWER display reads -5 dBm. Observe a full sweep. If oscillations occur, reduce the gain further by adjusting A4R11 (GAIN) counterclockwise.

27381 50 SHEETS 5 SQUARE
27382 100 SHEETS 5 SQUARE
27383 100 SHEETS 5 SQUARE
NATIONAL

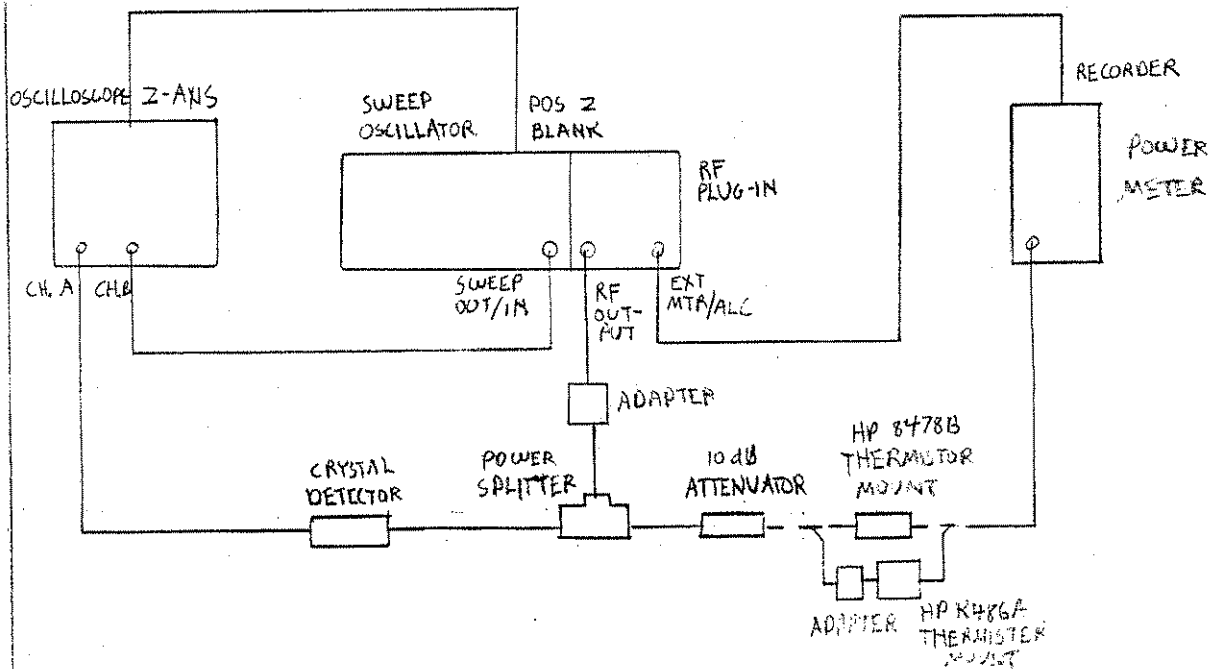

Figure 5-34. ALC Gain Adjustment Test Setup

A4

GAIN
A4R11

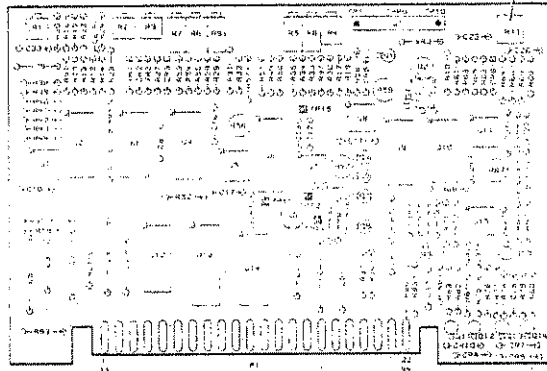

Figure 5-35 ALC Gain Adjustment Location

5-28. POWER SWEEP

REFERENCE:

Performance Test: 8350A Paragraph 4-14.
Service Sheet: A5

DESCRIPTION:

A 10 dB/sweep power sweep mode is selected and the resultant is displayed on the 8755C Swept Amplitude Analyzer. Output of the power sweep circuit is adjusted for the correct sweep.

EQUIPMENT:

Swept Amplitude Analyzer	HP 8755C
Display Mainframe	HP 180TR
Detector	HP 11664B
10 dB Attenuator	Weinschel Model M9-10
Sweep Oscillator	HP 8350A

PROCEDURE:

NOTE

ALC gain adjustments (paragraph 5-27) must be checked before power sweep adjustment are made.

NOTE

This procedure requires that A3S1 is set to the factory-set position (Table 5-6), and at the 8350A Sweep Oscillator, 27.8 kHz square wave modulation is selected.

1. Connect equipment as shown in Figure 5-36. On the 8350A, press [INSTR PRESET] [MOD]. Allow the equipment to warm up for 1 hour.
2. On the 8350A, press [SHIFT CW].
3. On the 83592A, press [POWER LEVEL]. Then, on the 8350A, press [0 dBm].
4. On the 83592A, press [POWER SWEEP]. Then, on the 8350A, press [10 dB].
5. While observing the 8755C display of the RF output, adjust ASR50 (PWSF) for a power level change across the display of

10 dB (10dB/sweep). Refer to Figure 5-37 for the adjustment location.

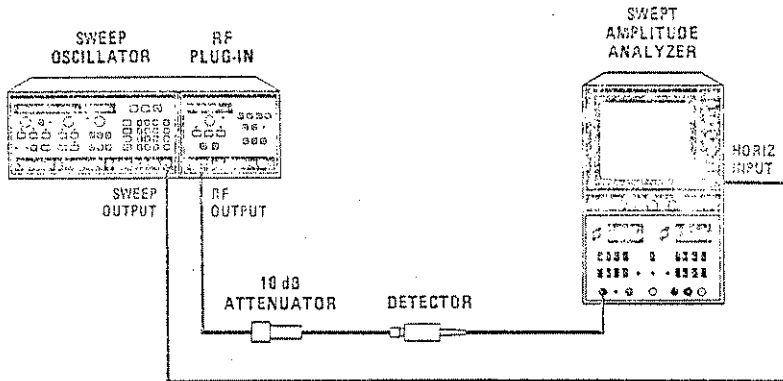

Figure 5-36. Power Sweep Test Setup

A5
PWSP (POWER SWEEP)
A5R50

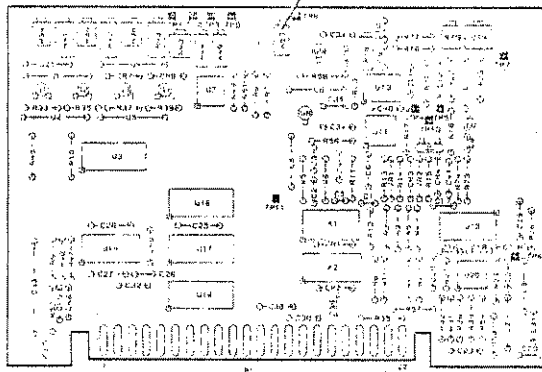

Figure 5-37, Power Sweep Adjustment Location

5-29. POWER METER LEVELING CALIBRATION

NOTE

Complete adjustment of the leveling loop for Power Meter leveling requires several procedures to be performed in the order prescribed from Paragraph 5-25 through 5-27, then 5-30. Deviation from this routine may cause improper leveling and/or power variation problems.

REFERENCE:

Performance Test: 8350A Paragraph 4-14.
Service Sheet: A4

DESCRIPTION:

Power Meter leveling gain potentiometer A4R9 (PM) calibrates loop gain to full-scale deflection of the leveling meter.

EQUIPMENT:

Power Meters	HP 432A and HP 436A
Thermistor Mount	HP 8478A
Power Sensor	HP 8485A
Power Splitter	HP 11667A
Sweep Oscillator	HP 8350A

PROCEDURE:

1. Connect equipment as shown in Figure 5-38. On the 8350A, press [INSTR PRESET CW] and select a frequency at midband. Set the RF power level to -2 dBm, as indicated on the 83592A POWER display. Allow the equipment to warm up for 1 hour.
2. Select the 0 dB range on the HP 432A Power Meter. Both meters should read approximately -8 dBm. Note the insertion loss through the Power Splitter (typically 6 dB).
3. On the 83592A, press [MTR LEVELING] and adjust the [CAL] potentiometer to reset the 432A to the same power measured in step 1.
4. Increase the 83592A power level until the 432A power meter reaches full scale deflection (83592A RF output equals approximately +6 dBm). Adjust A4R9 (PM) until the 436A Power Meter indication is equal to the 83592A POWER display minus the power splitter insertion loss noted in step 1

(approximately 6 dB). Refer to Figure 5-39 for the adjustment location.

5. Alternately set the 83592A POWER to -2 dBm (and adjust the 83592A [CAL] control) then set the 83592A POWER to +6 dBm (and adjust A4R9 (PM) control) to obtain best compromise (where further adjustment of each is unnecessary).

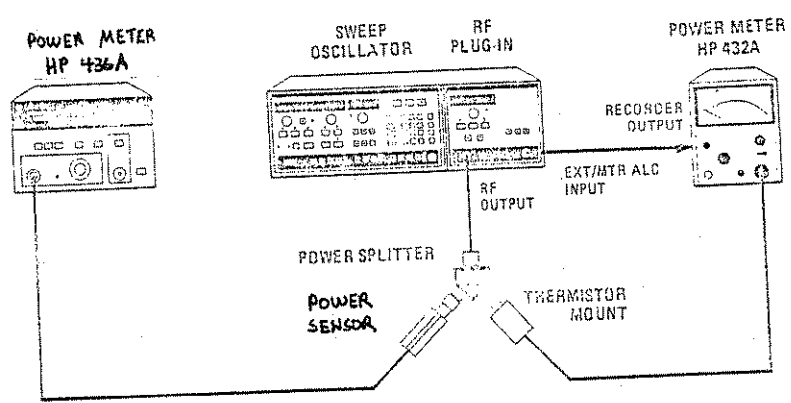

Figure 5-38 Power Meter Leveling Calibration

A4

PM (POWER METER)
A4R9

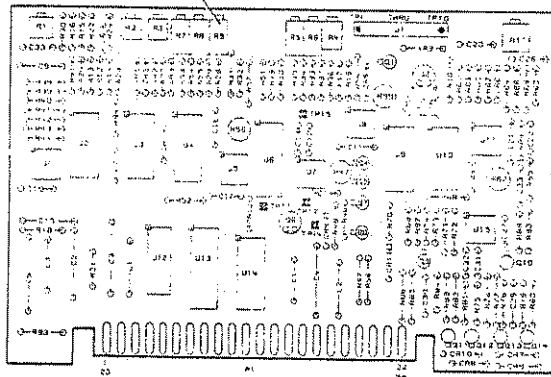

Figure 5-39. Power Meter Adjustment Location

5-30. FM DRIVER

REFERENCE:

Performance Test: 8350A Paragraph 4-20
Service Sheet: A5

DESCRIPTION:

The FM Driver high frequency offset is adjusted for zero volt drive with no FM modulation applied. A delay-line discriminator is used to detect and display FM modulation on an oscilloscope. Adjustments are for best overall frequency response from DC to 10 MHz. Compliance to a supplemental characteristic of ± 3 dB FM flatness is checked between DC and 2 MHz.

EQUIPMENT:

Digital Voltmeter (DVM)	HP 3455A
Oscilloscope	HP 1740A
Function Generator	HP 3312A
Delay Line Discriminator	See Figure 1-3
Frequency Counter	HP 5343A
DC Power Supply	HP 6213A
Sweep Oscillator	HP 8350A

PROCEDURE:

NOTE

Turn AC power OFF when removing or installing PC boards.

NOTE

This procedure requires that A3S1 is set to the factory-set position (refer to Table 5-6).

FM Offset

1. Connect the equipment as shown in Figure 5-40. Connect the Frequency Counter to the 83592A RF Output connector. Do not connect the Power Supply or Function Generator to the 8350A rear panel FM INPUT connector yet. Allow the equipment to warm up for 1 hour.
2. Connect the DVM between A5TP6 and A5TP7 (HIGH FREQ FM RET). Refer to Figure 5-41 for adjustment procedure locations.

Adjust A5R19 (FM) _____ for a DVM reading of 0.000 ± 0.001 Vdc.

3. Disconnect the DVM and set the equipment controls as follows:

8350A SWEEP OSCILLATOR

CW FREQUENCY 3 GHz
 FREQUENCY Sweep Mode Press SHIFT CW (swept CW)
 CW VERNIER On
 SWEEP TRIGGER INT
 RF BLANK OFF

83592A RF PLUG-IN

POWER LEVEL +10 dBm
 CW FILTER OFF
 ALC MODE INT
 Configuration switch A3S1 on Digital Interface board
 (Table 5-6) set as follows:

Switch No.	1	2	3	4	5	6	7	8
Position	1	X	X	0	0	0	*	X

Positions: 1=Open; 0=Closed; X=Dont't care
 * '0' if no Option 002; '1' if Option 002 installed.

NOTE

The A3S1 switch positions select the 83592A code, maximum RF power at power-up, -20 MHz/V FM sensitivity, cross-over coupled FM modulation (AC coupled), and Option 002 code (if installed).

3312A FUNCTION GENERATOR

RANGE 1 MHz
 FREQUENCY 10 (10MHz)
 FUNCTION Sine Wave
 Amplitude Set output for 100 mV p-p
 as displayed on Oscilloscope
 with 50 Ohm input

1740A OSCILLOSCOPE

MODE A vs. B

CHANNEL A	50 Ohms
CHANNEL A V/DIV	0.02 (CAL)
CHANNEL B INPUT	DC
CHANNEL B V/DIV	1

Frequency Response

4. Connect the Frequency Counter to the 83592A RF OUTPUT. Connect a +1 Vdc power supply to the 8350A rear panel FM INPUT. A shift in frequency of approximately -20 MHz should occur on the Frequency Counter when +1 Vdc is applied. (This shows correct FM modulation sensitivity.) Connect the Delay Line Discriminator to the 83592A RF OUTPUT and connect the Function Generator to the 8350A rear panel FM INPUT connector.
5. Adjust the 8350A [CW FREQUENCY] and [CW VERNIER] for a waveform at the center of the oscilloscope CRT. Adjust the oscilloscope Channel A 'CAL' control for a trace 4 divisions high centered on the CRT.
6. Manually sweep the Function Generator frequency from DC to 100 kHz. Select resistor A5R31 so that the amplitude of the CRT waveforms at Function Generator frequencies of 100 Hz and 100 kHz are the same ± 0.2 divisions on CRT. Refer to Figure 5-4 for A5R31 location. Refer to Table 5-2 for the allowable range of values for A5R31.
7. Manually sweep the Function Generator frequency from DC to 10 MHz. Adjust ASC14 (LO) and A5R75 (HI) controls to obtain the most constant overall response from DC to 10 MHz. Repeat this step several times.
8. Check that the ± 3 dB FM flatness supplemental characteristic is met between DC and 2 MHz as follows. Manually sweep the Function Generator frequency between DC and 2 MHz. On the oscilloscope, note the maximum and minimum response points as shown in Figure 5-4. Maximum point (+3dB) can be up to 5.6 divisions, and minimum point (-3 dB) can be down to 2.8 divisions.
9. If the FM flatness supplemental characteristic in step 10 above is not met, repeat step 8 and 9 above and make compromise adjustments in the DC to 2 MHz range to meet the requirements.
10. Reset the A3S1 Configuration switch to the desired position. Refer to Figure 5-6.

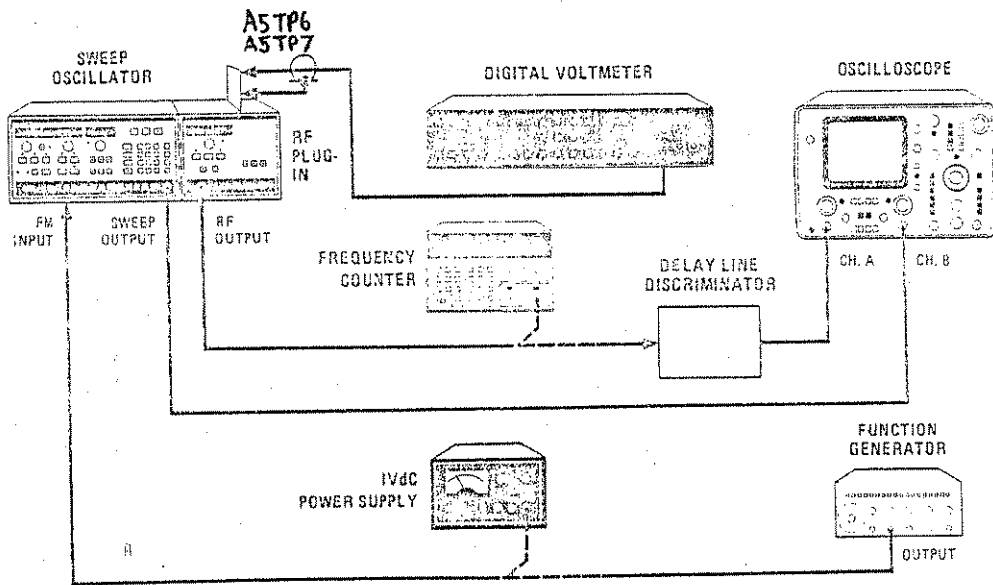

Figure 5-40. Test Setup for FM Driver Adjustments

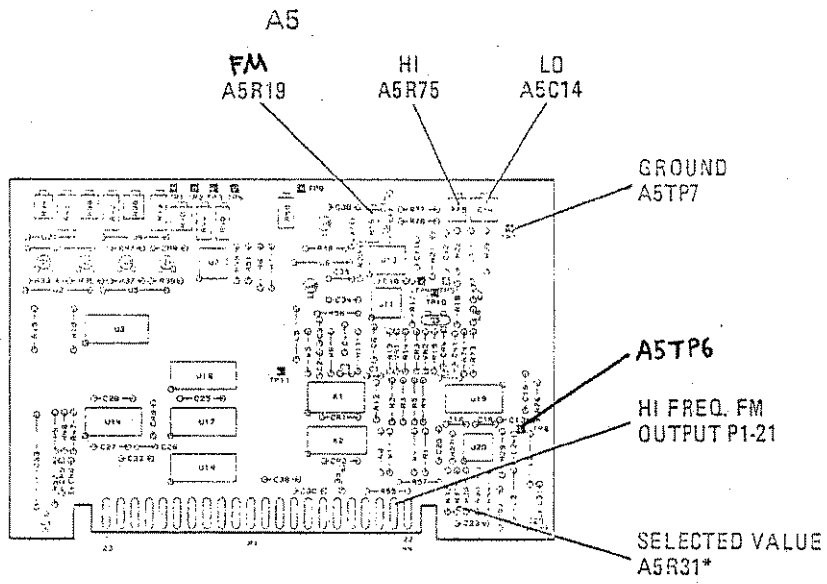

Figure 5-41. Location of A5 FM Driver Adjustments

HELEN
22 255 200 SHEETS
3 SQUARE
NATIONAL

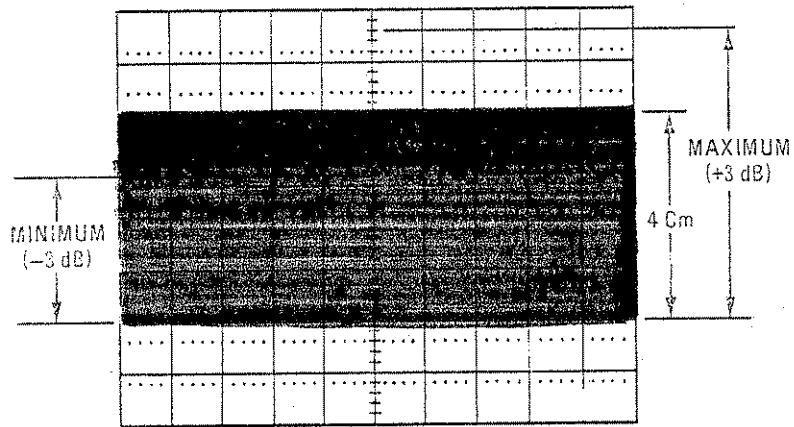

Figure 5-42. FM Flatness Tolerance, DC to 2 MHz

www.valuetronics.com