

HP 83525B operating & Service

SECTION I

GENERAL INFORMATION

1--1. INTRODUCTION

1--2. This Operating and Service Manual contains information required to install, operate, test, adjust, and service the Hewlett--Packard Model 83540B RF Plug--In. Figure 1--1 shows the Model 83540B.

1--3. This manual is divided into eight major sections which provide the following information:

- a. SECTION I, GENERAL INFORMATION, includes a brief description of the instrument, safety considerations, specifications, supplemental characteristics, instrument identification, options available, accessories available, and a list of recommended test equipment.
- b. SECTION II, INSTALLATION, provides information for initial inspection, preparation for use, rack mounting, storage, and shipment.
- c. SECTION III, OPERATION, explains the frequency resolution characteristics of the RF Plug--In in CW and swept frequency modes. Operating instructions include FM switch parameter settings, and crystal and power meter leveling instructions. A description of front and rear panel features and Plug--In error codes is also given.
- d. SECTION IV, PERFORMANCE TESTS, presents procedures required to verify that performance of the RF Plug--In is in accordance with published specifications.
- e. SECTION V, ADJUSTMENTS, presents procedures required to properly adjust and align the Model 83540B RF Plug--In after repair.
- f. SECTION VI, REPLACEABLE PARTS, provides information required to order all parts and assemblies.
- g. SECTION VII, MANUAL BACKDATING CHANGES, provides backdating information required to make this manual compatible with earlier shipment configurations.
- h. SECTION VIII, SERVICE, provides an overall instrument block diagram with troubleshooting and repair procedures. Each assembly within the instrument is covered on a separate Service Sheet which contains a circuit description, schematic diagram, component location diagram, and troubleshooting information to aid in the proper maintenance of the instrument.

1--4. Supplied with this manual is an Operating Information Supplement. This is simply a copy of the first three sections of the manual, which should be kept with the instrument for use by the instrument operator.

1--5. On the front cover of this manual is a Microfiche part number. This number may be used to order 10-- by 15--centimetre (4-- by 6--inch) microfilm transparencies of the manual. Each microfiche contains up to 60 photo duplicates of the manual pages. The microfiche package also includes the latest Manual Changes sheet as well as all pertinent Service Notes.

1--6. Refer any questions regarding this manual, the Manual Changes sheet, or the instrument to the nearest HP Sales/Service Office. Always identify the instrument by model number, complete name, and complete serial number in all correspondence. Refer to the inside rear cover of this manual for a worldwide listing of HP Sales/Service Offices.

1--7. SPECIFICATIONS

1--8. Listed in Table 1--1 are the specifications for the Model 83540B RF Plug--In. These specifications are the performance standards, or limits, against which the instrument may be tested. Table 1--2 lists the RF Plug--In supplemental performance characteristics. Supplemental performance characteristics are not specifications but are typical characteristics included as additional information for the user.

1--9. SAFETY CONSIDERATIONS

1--10. This product has been manufactured and tested in accordance with international safety standards. Before operation, this product and related documentation must be reviewed for familiarization with safety markings and instructions. A complete listing of Safety Considerations precedes Section I of this manual.

1--11. INSTRUMENTS COVERED BY MANUAL

1--12. Attached to the rear panel of the instrument is a serial number plate. A typical serial number plate is shown in Figure 1--2. The serial number is in two parts. The first four digits followed by a letter comprise the serial number prefix. The last five digits form the sequential suffix that is unique to each instrument. The content of this manual applies directly to instruments having the serial number prefix listed on the title page of this manual under SERIAL NUMBERS.

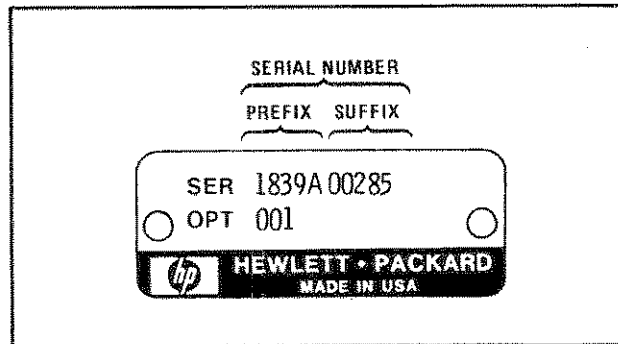

Figure 1-2. Typical Serial Number Plate

1--13. An instrument manufactured after the printing of this manual may have a serial prefix that is not listed on the title page. An unlisted serial prefix indicates that the instrument is different from those documented in this manual. In this case, the manual for the instrument is supplied with a Manual Changes supplement that contains information which documents the differences.

1--14. In addition to change information, the Manual Changes supplement may contain information for correcting errors in the manual. To keep this manual as current as possible, Hewlett--Packard recommends that you periodically request the latest Manual Changes supplement. The supplement for this manual is keyed to the manual's print date and part number, both of which appear on the title page. Complimentary copies of the Manual Changes supplement are available on request from Hewlett--Packard.

1--15. For information concerning a serial number prefix that is not listed on the title page or in the Manual Changes supplement, contact your nearest Hewlett--Packard Sales/Service Office.

1--16. DESCRIPTION

1--17. The Model 83525B is an RF Plug--In which has been designed for use with the Model 8350A Sweep Oscillator. The Model 83525B covers the frequency range of 0.01 to 8.4 GHz in two bands. A YIG Oscillator is used as the tunable RF frequency source for both bands. The upper band (Band 1) frequency range, 2.0 to 8.4 GHz, is obtained by amplifying the direct YIG Oscillator output. This output is then filtered by a YIG Tuned Filter in the YIG Oscillator housing, to reduce harmonics and unwanted spurious signals. The lower band (Band 0) uses a fixed 3.8 GHz oscillator which is mixed with the YIG Oscillator to generate a 0.01 to 2.1 GHz RF output. Internal RF switches select the proper band to be output and are automatically switched when the frequency range being swept requires that both bands be utilized.

1--18. Model 83525B front panel functional controls, pushbuttons, and

the Rotary Pulse Generator (RPG), are monitored by the Model 8350A via the RF Plug--In interface circuits. The Model 8350A generates a tuning voltage ramp according to the mode of operation (CW, START/STOP, CF/^DF). This voltage ramp is scaled and offset in the Model 8350A to provide a voltage ramp which is proportional to the YIG Oscillator frequency in the Model 83525B. The Model 83525B tuning circuits accept the tuning ramp voltage output by the Model 8350A and convert it to a current which drives the YIG Oscillator tuning coil.

1--19. The Model 83525B offers a maximum leveled RF output power of +13 dBm in the 0.01 to 2.0 GHz band, and +10 dBm in the 2.0 to 8.4 GHz frequency band. Internal (INT), External (EXT), and Power Meter (MTR) leveling are available as selected by the front panel pushbuttons. A front panel EXT/MTR ALC input connector and gain control (CAL) are provided to use with an external leveling loop. A front panel LED indicates when the RF output becomes unleveled. The RF output level is controlled by the Model 83525B RPG, the Model 8350A data entry controls (keypad and step keys), or through HP--IB (Hewlett Packard Interface Bus) control via the Model 8350A. HP--IB is Hewlett Packard's hardware, software, documentation, and support for IEEE--488 and IEC--625, worldwide standards for interfacing instruments.

1--20. Internal crystal referenced frequency markers are available in the 0.01 to 2.0 GHz band to provide Z--axis intensity markers from the Model 8350A rear panel POZ Z BLANK BNC output or 1 dB amplitude marker dips on the RF output. Harmonic markers of 10 and 50 MHz are available up to 2 GHz and 1 MHz markers are available up to 1 GHz. A rear panel BNC connector accepts an external marker reference frequency. Marker operation is selected by the front panel controls or through HP--IB control via the Model 8350A.

1--21. A power sweep function allows the RF output power to be swept at least 15 dB during CW mode or swept frequency modes. Power sweep is selected by the front panel POWER SWEEP pushbutton. Slope compensation control is also available by selecting the SLOPE pushbutton and rotating the Model 83525B RPG or manipulating the Model 8350A data entry controls. The power sweep function and slope compensation may both be selected and modified through HP--IB control via the Model 8350A.

1--22. The RF output may be internally or externally amplitude modulated, or externally frequency modulated. The internal squarewave modulation frequency is selectable by the Model 8350A front panel or HP--IB. An internal 8350A jumper selects either 1 kHz or 27.8 kHz (for use with the Model 8755 Swept Amplitude Analyzer). Rear panel BNC connectors accept an external AM or FM frequency. FM coupling (direct coupled or cross--over) and sensitivity are selected by an internal configuration switch in the Model 83525B. Refer to Section III, Operation, of this manual for detailed information on the configuration switch.

1--23. A rear panel 1V/GHz signal corresponds to the RF output frequency. This output voltage may be used as a reference for pretuning external equipment in phase--locking applications. (The Model 8410B/8411A Network Analyzer utilizes this output in such a configuration).

1--24. The RF output may be turned off by the RF ON/OFF pushbutton. RF power ON is indicated by the LED in the center of the pushbutton. Additionally, in CW mode, the CW FILTER, when selected, places a capacitor across the YIG Oscillator tuning coil to filter high frequency noise which would appear at the RF output. All front panel functions, with the exception of the FREQ CAL and CAL adjustments, may be set or altered by computer control via the HP--IB bus connection on the Model 8350A.

1--25. OPTIONS

1--26. Option 002, 70 dB Attenuator

1--27. Option 002 instruments contain a digitally controlled attenuator just ahead of the RF output. Up to 70 dB of attenuation in 10 dB steps is automatically selected as required to attenuate the RF output power to the indicated level. The continuously variable power level function operates as in a standard instrument with the data entry controls.

1--28. Option 004, Rear Panel RF Output

1--29. Option 004 instruments have the Type N RF OUTPUT connector and the BNC EXT/MTR ALC input connector on the rear panel instead of the front panel.

1--30. EQUIPMENT REQUIRED BUT NOT SUPPLIED

1--31. To have a complete operating sweep oscillator unit, the Model 83525B RF Plug--In must be installed in a Model 8350A Sweep Oscillator mainframe. Refer to Section II, Installation, in this manual for a detailed description of RF Plug--In installation.

1--32. EQUIPMENT AVAILABLE

1--33. Service Accessories

1--34. A Service Accessory Kit (HP Part Number 08350--60020) is available for servicing the Model 83525B RF Plug--In and the Model 8350A Sweep Oscillator. HP Part Numbers for the individual pieces of the kit are provided in Table 1--3. The accessory kit includes:

^u Two 44--pin printed circuit board extenders. These boards have

keyed slots which allow them to be used in each of the keyed PC board receptacles in the Model 83525B, as well as in the Model 8350A.

- ^u An RF Plug--In extender cable set that provides all electrical connections when the RF Plug--In is removed from the Sweep Oscillator. The RF Plug--In Interface connector (P2) and the Power Supply Interface connector (P1) are extended by separate cables.
- ^u One Hex Balldriver for use in Model 8350A front panel repairs.
- ^u One 16--pin and one 20--pin I.C. Test Clip for probing integrated circuits.

1--35. A listing of service accessories available including service cables, wrenches, adapters, and extender boards is given in Table 1--3.

1--36. Model 8410B/8411A Network Analyzer

1--37. The Model 8350A Sweep Oscillator, with the Model 83525B RF Plug--In installed, is compatible with the HP Model 8410B Network Analyzer system. The combination of the Model 8410B Network Analyzer, the Model 8411A Frequency Converter, and an appropriate display Plug--In, forms a phasemeter and a ratiometer for direct phase and amplitude ratio measurement of RF voltages. These measurements can be made on CW frequencies and on swept frequencies from 110 MHz to 18 GHz. The Model 8350A/83525B combination is capable of operation from 110 MHz to 8.4 GHz within this range. The Model 8410B has an Auto--Frequency range mode which gives it the capability of automatically tracking the Model 8350A Sweep Oscillator over octave and multi--octave frequency bands. Two interconnections to the Model 8350A are necessary to ensure that the Model 8410B will phase--lock properly. The Model 8410B Source Control Cable (HP 08410--60146) connects the Model 8410B rear panel SOURCE CONTROL connector to the Model 8350A rear panel PROGRAMMING CONNECTOR. Additionally, the Model 83525B RF Plug--In rear panel 1V/GHz output connects to the Model 8410B rear panel FREQ REF INPUT. The Model 8410B Source Control Cable connector pins and signals are illustrated in the Model 8350A Sweep Oscillator Operating and Service Manual.

1--38. Model 8755 Frequency Response Test Set

1--39. The Model 8350A Sweep Oscillator with the Model 83525B RF Plug--In installed is compatible with the Model 8755 Frequency Response Test Set for broadband swept scalar measurements. The Model 8350A provides internal 27.8 kHz squarewave amplitude modulation of the RF output, eliminating unnecessary cable connections to the Model 8755 or

the use of an external modulator. The Model 8350A can also produce alternate sweeps through use of the ALT n function which works in conjunction with the channel switching circuits in the Model 8755C. This permits Channel 1 on the Model 8755C to respond only to the Model 8350A current state and Channel 2 to respond to the alternate state. A single cable (HP Part Number 8120--3174) connects between the Model 8350A rear panel ALT SWP INTERFACE connector and the Model 8755C front panel ALT SWP INTERFACE connector.

1--40. Power Meters and Crystal Detectors

1--41. The RF output can be externally leveled using the HP Model 432 Power Meter or negative polarity output crystal detectors. Refer to Section III, Operation, of this manual for detailed information on leveling techniques that may be used with the Model 8350A/RF Plug--In combination.

NOTE

The Model 435A and 436A Power Meters should not be used in Model 8350A/Model 83525B external leveling systems.

1--42. RECOMMENDED TEST EQUIPMENT

1--43. Equipment required for testing and adjusting the instrument is listed in Table 1--4. Other equipment may be substituted if it meets or exceeds the critical specifications indicated in the table.

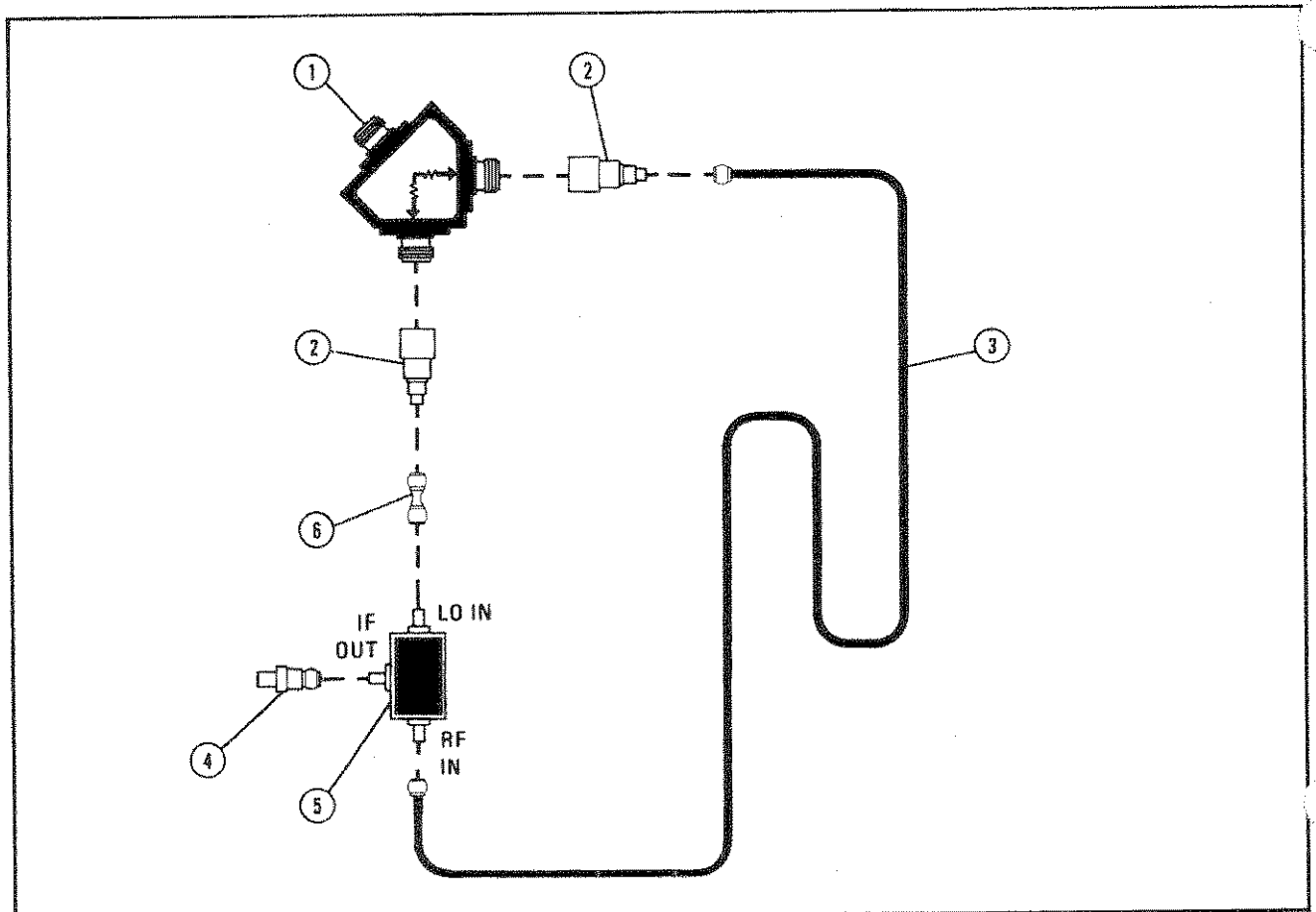

Item	Description	HP Part Number
1	Power Splitter	HP 11667A
2	Adapter: Type N Male to SMA Female (2 required)	1250-1250
3	Delay Line: >1 meter (3 feet) in length, SMA male connectors	08503-20038
4	Adapter: BNC Female to Male SMA	1250-1200
5	Mixer: Double Balanced 1 to 12 GHz: RHG Electronics Part No. DM 1-12 1 to 18 GHz: RHG Electronics Part No. DM 1-18 RHG Electronics Laboratories, Inc. Deer Park, NY 11729	0960-0451 None
6	Adapter: SMA Male to SMA Male	1250-1159

Figure 1-3. Delay Line Discriminator

Table 1--1. Specifications for Model 83525B
Installed in Model 8350A (page 1 of 6)

FREQUENCY/11

<u>Range:</u>	0.01 to 8.4 GHz		
Frequency Bands	<u>0.01 to 2 GHz</u>	<u>2 to 8.4 GHz</u>	<u>0.01 to 8.4 GHz</u>
<u>Accuracy:</u> (25°C ± 5°C)			
CW Mode:	±5 MHz/21	±12 MHz	±12 MHz
All Sweep Modes: (Sweep time ≥100 ms)	±15 MHz/21	±20 MHz	±25 MHz
Frequency Markers: (Sweep time ≥100 ms)	±15 MHz ±0.5% of sweep width/21	±20 MHz ±0.5% of sweep width	±25 MHz ±0.5% of sweep width

Stability:

With 10% Line Voltage Change:	±20 kHz	±20 kHz
With 10 dB Power Level Change:	±100 kHz	±1 MHz
With 3:1 Load SWR:	±10 kHz	±250 kHz
Residual FM, Peak: (10 Hz to 10 kHz Bandwidth)	<5 kHz	<7 kHz

Table 1--1. Specifications for Model 83525B
Installed in Model 8350A (page 2 of 6)

POWER OUTPUT

Maximum Levelled Output Power: +10 dBm
(25°C ± 5°C)

With Option 002: +10 dBm

Power Level Accuracy: ±1.5 dB
(Internally Levelled)

With Option 002: ±1.7 dB
(at 0 dB attenuator step)

Minimum Settable Power: -5 dBm

With Option 002: -75 dBm

Attenuator Accuracy (± dB referenced from the 0 dB setting)

	<u>Attenuator Setting (dB)</u>						
	<u>10</u>	<u>20</u>	<u>30</u>	<u>40</u>	<u>50</u>	<u>60</u>	<u>70</u>
<u>Attenuator Accuracy</u>	0.5	0.7	0.9	1.2	1.5	1.8	2.1

Power Variation:

(at specified Maximum Levelled Power or below)*

Internally Levelled: ±1 dB

Externally Levelled:

Negative Crystal Detector: ±0.1 dB

Power Meter: ±0.1 dB

*Option 002: at 0 dB attenuation step only

Table 1--1. Specifications for Model 83525B
Installed in Model 8350A (page 3 of 6)

POWER OUTPUT (CONT'D)

Frequency Bands	<u>0.01 to 2 GHz</u>	<u>2 to 8.4 GHz</u>
<u>Residual AM in 100 kHz Bandwidth</u> (in dB below carrier and at specified Maximum Levelled Power):	≥50 dB	≥50 dB
<u>Spurious Signals</u> (at specified Maximum Levelled Power):		
Harmonics (in dB below carrier):	≥25 dB	≥45 dB
Non-Harmonics (in dB below carrier):	≥30 dB	≥60 dB
<u>Output SWR</u> (internally levelled):	≤2.0	≤1.6
<u>Power Sweep</u> '91		
Calibrated Range'81:	≥15 dB	

Table i--1. Specifications for Model 83525B
Installed in Model 8350A (page 4 of 6)

MODULATION'11

External AM:

Maximum Input: 15 V

Internal AM

Selectable (by internal jumper in 8350A) to 1 kHz or 27.8 kHz squarewave modulation. The 27.8 kHz modulation allows operation with HP Model 8755A/B/C Swept Amplitude Analyzer.

On/Off Ratio: ≥ 30 dB below specified Maximum Levelled Power

Symmetry: 40/60

External FM

Maximum Deviations for Modulation Frequencies:

	<u>Cross Over Coupled</u>	<u>Direct Coupled</u>
DC to 100 Hz:	± 75 MHz	± 12 MHz
100 Hz to 1 MHz:	± 7 MHz	± 7 MHz
1 MHz to 2 MHz:	± 5 MHz	± 5 MHz
2 MHz to 10 MHz:	± 1 MHz	± 1 MHz

Table 1--1. Specifications for Model 83525B
Installed in Model 8350A (page 5 of 6)

CRYSTAL MARKER CAPABILITY

Internal Crystal Markers (+3 to +10 dBm power level and 10 markers/sweep): Harmonic Markers of 10 MHz and 50 MHz are available below 2 GHz; 1 MHz harmonic markers are available below 1 GHz. Markers are output as intensity spots through the POS Z BLANK connector on the 8350A or as amplitude dips on the RF output.

External Marker Input: Generates amplitude or Z-axis marker when sweep frequency equals external input frequency.

Frequency Range: 0.01 to 2.0 GHz

Marker Indicator Light: LED lights when coincident with crystal or external marker for accurate CW calibration.

GENERAL SPECIFICATIONS

Minimum Sweep Time (over full band): 17 ms

Bandswitch Point: Internal bandswitch point between 2.0 and 2.1 GHz

RF Output Connector: Type N Female

- 1 Unless otherwise noted, all specifications are at the RF OUTPUT connector and at 0° to 55°C.
- 2 Accuracy when calibrated using internal crystal markers and FREQ. CAL. adjustment.
- 3 For temperatures greater than 30° C, Maximum Levelled Output Power typically degrades 0.1 dB/degree C.
- 4 Excludes coupler and detector variation. Crystal detector output should be between -10 mV and -200 mV at specified Maximum Levelled Power.
- 5 Use HP Model 432A/B/C Power Meter. Sweep duration \geq 50 seconds.
- 6 Attenuator switch points are every 10 dB starting at -5 dBm indicated power.
- 7 Discontinuity at bandswitch is typically 0.25 dB.
- 8 With Option 002, in Power Sweep or Slope functions, power can exceed attenuator step by the amount that the Power Sweep calibrated range exceeds 10 dB (e.g., if the calibrated range is 12 dB, power can exceed the attenuator step by 2 dB).
- 9 Power Sweep and Slope compensation total must not exceed 15 dB.
- 10 Includes internally levelled power variation.

Table 1--2. Supplemental Performance Characteristics for Model 83525B
Installed in Model 8350A (1 of 4)

NOTE

Values in this table are not specifications, but are typical characteristics
included for user information.

FREQUENCY CHARACTERISTICS(1)

Accuracy

(25°C ±5° C)

CW Mode typically:

0.01 to 2.0 GHz: ±1.5 MHz

2.0 to 8.4 GHz: ±3.5 MHz

Manual Sweep:

0.01 to 2.0 GHz: ±10 MHz(2)

2.0 to 8.4 GHz: ±30 MHz

All Sweep Modes (sweep time 10 ns to 100 ns): ±25 MHz(2)

Sweep Mode Linearity(3):

0.01 to 2.0 GHz: ±2 MHz

2.0 to 8.4 GHz: ±3 MHz

Stability

With Temperature: ±200 kHz/° C

With Time (in a ten minute period after one hour warmup at the same frequency setting):

0.01 to 2.0 GHz: (<±50 kHz

2.0 to 8.4 GHz: (<±50 kHz

Table 1--2. Supplemental Performance Characteristics for Model 83525B
Installed in Model 8350A (2 of 4)

OUTPUT CHARACTERISTICS:11

Power Output

Resolution (displayed): 0.1 dB

Remote Programming (settable): Typically ± 0.01 dB

Stability with Temperature (at specified Maximum Levelled Power): ± 0.02 dB/ $^{\circ}$ C

Spurious Signals (in dB below carrier):

Frequency Bands	<u>0.01 to 2 GHz</u>	<u>2 to 8.4 GHz</u>
<u>Harmonics:</u>		
At specified Maximum Levelled Power, typically:	≥ 30 dB	≥ 50 dB
At power level of +7 dBm, typically:	≥ 35 dB	≥ 55 dB
Non Harmonics at specified Maximum Levelled Power, typically:	≥ 35 dB	≥ 60 dB

Impedance: 50 Ohms

Power Sweep:151

Accuracy (including Linearity): Typically ± 1.5 dB

Resolution (displayed): 0.1 dB

Slope Compensation:151

Linearity: Typically < 0.2 dB

Calibrated Range:141 Up to 5 dB/GHz; up to 15 dB for full sweep range

Resolution (displayed): 0.1 dB/GHz

Table 1--2. Supplemental Performance Characteristics for Model 83525B
Installed in Model 8350A (3 of 4)

MODULATION CHARACTERISTICS

External AM:

Frequency Response: Typically 100 kHz

Input Impedance: Approximately 10k Ohm

Range of Amplitude Control: Typically 15 dB

Sensitivity: Typically 1 dB/V

Pulse In

TTL compatible: Logic HIGH = RF ON
Logic LOW = RF OFF

Modulation for 0.01 to 2.0 GHz Band

Squarewave Modulation up to 30 kHz

Pulse Modulation for 2.0 to 8.4 GHz Band

Rise/Fall Time: Typically 20 ns

Minimum Pulse Width:

Levelled: Typically 5 μ s

Unlevelled (power level set to +19 dBm): Typically 100 ns

External FM:

Frequency Response (DC to 2.0 MHz): ± 3 dB

Sensitivity (switch selectable):

FM Mode: Typically -20 MHz/V

Phaselock Mode: Typically -6 MHz/V

Input Impedance: 2000 Ohms nominal

Table 1--2. Supplemental Performance Characteristics for Model 83525B
Installed in Model 8350A (4 of 4)

CRYSTAL MARKER (Operation with RF power set between +3 and +13 dBm, and 10 markers per sweep)

Accuracy of Center Frequencies (at 25° C): $\pm 5 \times 10^{-6}$

Typical Marker Width Around Center Frequency:

1 MHz Markers: ± 100 kHz

10 MHz Markers: ± 200 kHz

50 MHz Markers: ± 300 kHz

External Markers: ± 300 kHz

Temperature Stability: Typically $\pm 2 \times 10^{-6}/^{\circ}\text{C}$

EXTERNAL MARKER INPUT: 1'61 Generates Amplitude or Z--axis marker when sweep frequency equals external input frequency.

Frequency Range: 0.01 to 2.0 GHz

GENERAL CHARACTERISTICS

Frequency Reference Output: 1 V/GHz ± 25 mV (over full sweep range) rear panel BNC output

Weight: Net 4.5 kg (10 lb.), Shipping 7.7 kg (17 lb.)

-
- 1 Unless otherwise noted, all characteristics are at the RF OUTPUT connector and at 0° to 55° C.
 - 2 Accuracy when calibrated using internal crystal markers and FREQ CAL adjustment.
 - 3 With respect to the SWEEP OUT voltage.
 - 4 With Option 002, in Power Sweep or Slope functions, power can exceed attenuator step by the amount that the Power Sweep calibrated range exceeds 10 dB (e.g., if the calibrated range is 12 dB, power can exceed the attenuator step by 2 dB).
 - 5 Power Sweep and Slope compensation must not exceed 15 dB.
 - 6 External marker input power typically between -10 dBm and +10 dBm (over limited power range).

Table 1--3. Model 83525B Service Accessories Available

<u>NAME</u>	<u>HP PART NUMBER</u>	<u>DESCRIPTION</u>
44-pin printed circuit board extender	08350-60031*	Extends printed circuit boards
RF Plug--In Extender Cables	08350-60034*	Extends RF Plug--In Interface connector (P2)
	08350-60035*	Extends RF Plug--In Power Supply Interface connector (P1)
Adjustment Tool	8830-0024	Fits miniature adjustment slot on potentiometers
Wrenches	08555-20097	5/16" slotted box/open end
	8710-0946	15/64" open end
Service Cables	8120-1578	18" coax with SMA (m) connector on each end
	83525-60019	10" coax with SMB snap on (f) and SMA (m)
Adapters	1250-0777	Type N (f) to BNC (m)
	1250-0082	Type N (m) to BNC (m)
	1250-1404	Type N (f) to SMA (f)
	1250-1158	SMA (f) to SMA (f)
	1250-0674	SMA (f) to SMB (m)
	1250-0675	SMA (f) to SMC (m)
	1250-0069	SMB snap on (m) to SMB snap on (m)
	1250--1744	APC--3.5 (f) to Type N (m)
Hex Balldriver	8710--0523*	Removes front panel hold--down plate hex screws in 8350A
IC Test Clip	1400--0734*	16--pin IC test clip
	1400--0979*	20--pin IC test clip

*These items are included in a Service Accessories Kit HP Part No. 08350--60020 (2 board extenders are included in this kit).

Table 1-4. Recommended Test Equipment (1 of 3)

Instrument	Critical Specifications	Recommended Model	Use ¹
Sweep Oscillator	No substitute	HP 8350A	P,A,T
Digital Voltmeter (DVM)	Range: -50V to +50V Accuracy: $\pm 0.01\%$ Input Impedance: $\geq 10M$ Ohms	HP3455A	P,A,T
Oscilloscope	Dual Channel Bandwidth: dc to 100 MHz Vertical Sensitivity: ≤ 5 mV/Div Horizontal Sweep Rate: $\leq 0.1 \mu$ S/Div X vs. Y Display Mode	HP 1740A	P,A,T
Frequency Counter	Frequency Range: 0.01 to 8.4 GHz	HP 5343A	P,A
Spectrum Analyzer	Frequency Range: 0.01 to 18 GHz Residual FM: ≤ 100 Hz Must have auxiliary IF output when used with the HP 8901A Modulation Analyzer	HP 8565A or HP 8566A	P,T
Modulation Analyzer	(May be used in addition to Spectrum Analyzer). Frequency Range: Must cover auxiliary IF Output frequency of Spectrum Analyzer used. Residual FM: ≤ 10 Hz	HP 8901A	P,T
Swept Amplitude Analyzer	Capable of Transmission and Reflection measurements. Power Resolution: ≤ 0.25 dB/Div	HP 8755C	P,A
Display Mainframe	Compatible with HP 8755C Swept Amplitude Analyzer and HP 8750A Storage-Normalizer	HP 182T, TR	P,A
Detector	Compatible with Swept Amplitude Analyzer Frequency Range: 0.01 to 8.4 GHz Power Range: -20 to +10 dBm	HP 11664A	P,A
Storage-Normalizer	Compatible with Display Mainframe and Swept Amplitude Analyzer	HP 8750A	P,A
RF Marker Source	CW Frequency: 1.2 GHz Output Power Level: ≥ -10 dBm	HP 8350A/83522A	A
Frequency Meter	Frequency Accuracy: $\leq 0.17\%$ Calibration Increments: ≤ 2 MHz Frequency Range: 0.96 to 4.0 GHz 4.0 to 8.4 GHz	HP 536A HP 537A	P,A P,A

Table 1-4. Recommended Test Equipment (2 of 3)

Instrument	Critical Specifications	Recommended Model	Use ¹
Attenuator	Attenuation: 3 dB ± 0.5 dB Frequency Range: 0.01 to 8.4 GHz Maximum Input Power: ≥ +20 dBm Type-N Connector	HP 8491B Option 003	P
Attenuator	Attenuation: 6 dB ± 0.5 dB Frequency Range: 0.01 to 8.4 GHz Maximum Input Power: ≥ +20 dBm Type-N Connector	HP 8491B Option 006	P
Attenuator	Attenuation: 10 ± 0.5 dB Frequency Range: 0.01 to 8.4 GHz Maximum Input Power: ≥ +20 dBm Type-N Connector	HP 8491B Option 010	P,A
Attenuator	Attenuation: 20 ± 0.5 dB Frequency Range: 0.01 to 8.4 GHz Maximum Input Power: ≥ +20 dBm Type-N Connector	HP 8491B Option 020	P
Adjustable Short	Frequency Range: 1.8 to 12.4 GHz Impedance: 50 ± 1.5 Ohms	Maury Microwave ² 1953-2	P
Adapter	APC-7 to Type N(m)	HP 11525A	P
Adapter	APC-3.5(f) to Type N(m)	HP 1250-1744	P
Directional Coupler	Frequency Range: 0.1 to 2.0 GHz Nominal Coupling: ≥ 20 dB Maximum Coupling Variation: ≤ ± 1 dB Minimum Directivity: ≥ 32 dB	HP 778D	P
Directional Coupler	Frequency Range: 2 to 8.4 GHz Mean Output Coupling: ≥ 20 dB Output Coupling Variation: ≤ ± 1 dB Minimum Directivity: ≥ 26 dB	HP 779D	P
RMS Voltmeter	dB Range: -20 to -70 dBm (0 dBm = 1 mW into 600 Ohms) Frequency Range: 10 Hz to 10 MHz Accuracy: ±5% of full scale	HP 3400A	P
Air Line Extension (2 required)	Impedance: 50 Ohms Frequency Range: dc to 8.4 GHz Reflection Coefficient: 0.018 + 0.001 (times the frequency in GHz)	HP 11567A	P
Step Attenuator	Frequency Range: dc to 8.4 GHz Incremental Attenuation: 0 to 70 dB in 10 dB steps Calibration Accuracy: ≤ ± 0.1 dB at all steps	HP 8495A Option 890	P

Table 1-4. Recommended Test Equipment (3 of 3)

Instrument	Critical Specifications	Recommended Model	Use ¹
Function Generator	Frequency Range: 0.1 Hz to 10 MHz Sine wave and square wave output Output Level: 10 V p-p into 50 Ohms Output Level Flatness: $\leq \pm 3\%$ from 10 Hz to 100 kHz $\leq \pm 10\%$ from 100 kHz to 10 MHz	HP 3312A	P,A,T
Power Meter	Power Range: -20 to +10 dBm (No substitute when used for external power meter leveling).	HP 432A	P,A
Thermistor Sensor (Used with HP 432A)	Frequency Range: 0.01 to 8.4 GHz Maximum SWR: ≤ 1.75	HP 8478B	P,A
Power Meter	Power Range: 1 μ W to 100 mW	HP 436A	P,A
Power Sensor (Used with HP 436A)	Frequency Range: 0.01 to 8.4 GHz	HP 8481A	P,A
Crystal Detector	Frequency Response: 0.01 to 8.4 GHz Maximum Input Power: 100 mW	HP 423B	P,A
Power Splitter	Frequency Range: 0.01 to 8.4 GHz Output Port Tracking: ≤ 0.25 dB Maximum Input Power: +20 dBm	HP 11667A	P,A
Band Pass Filters	Frequency Range: 4 to 8 GHz 6 to 8 GHz 8 to 12.4 GHz	HP Part No. 0960-0402 HP Part No. 0960-0200 HP Part No. 0960-0403	A A A
DC Power Supply	DC Output: 0 to 6.5 Vdc \pm 0.05 Vdc	HP 6213A	A
50 Ohm Termination	Type N, 50 Ohms \pm 0.5 Ohms	HP 909A	P,A
Delay Line Discriminator	Refer to Figure 1-3.		

¹ P = Performance Test; A = Adjustments; T = Troubleshooting

² Maury Microwave Corp., 8610 Helms Ave., Cucamonga, CA 91730

SECTION II

INSTALLATION

2--1. INTRODUCTION

2--2. This section provides installation instructions for the Model 83525B RF Plug--in. This section also includes information about initial inspection, and damage claims, preparation for use, and packaging, storage, and shipment.

2--3. INITIAL INSPECTION

2--4. Inspect the shipping container for damage. If the shipping container or cushioning material is damaged, it should be kept until the contents of the shipment have been checked for completeness and the instrument has been checked mechanically and electrically. The contents of the shipment should be as shown in Figure 1--1. Procedures for checking electrical performance are given in Section IV, Performance Tests, in the Model 8350A Operating and Service Manual. Performance Test limits are given in Section IV of this manual. If the instrument combination does not pass the electrical Performance Tests, refer to Section V, Adjustments, of this manual. If, after the adjustments have been made, the instrument combination still fails to meet specifications, and a circuit malfunction is suspected, refer to troubleshooting procedures in Section VIII, Service, in this manual. If the instrument does not pass the above electrical tests, if the shipment contents are incomplete, or if there is mechanical damage or defect, notify the nearest Hewlett--Packard office. If the shipping container is damaged, or if the cushioning material shows signs of stress, notify the carrier as well as the Hewlett--Packard office. Keep the shipping materials for carrier's inspection. The HP office will arrange for repair or replacement without waiting for claim settlement.

2--5. PREPARATION FOR USE

2--6. Power Requirements

2--7. When the Model 83525B RF Plug--in is properly installed, it obtains all power through the rear panel interface connector from the Model 8350A Sweep Oscillator.

2--8. RF Plug--in Configuration Switch

2--9. The Model 83525B RF Plug--in has a configuration switch (A3S1) located on the A3 Digital Interface Board. This switch must be preset prior to RF Plug--in operation in the Model 8350A. The configuration switch is an 8--section multiple switch. Each of the separate switches corresponds to a separate RF plug--in function such as FM sensitivity selection, FM modulation input coupling selection (direct coupled or

cross-over), RF power level at power on (minimum or maximum), and Option 002 Step Attenuator operation. Refer to Section III, Operation, in this manual for a complete description of the configuration switch and instructions on how to set the switches.

2--10. Interconnections

2--11. There are two rear panel interconnections on the Model 83525B RF Plug-in to the Model 8350A Sweep Oscillator. These are the RF Plug-in Interface connector (P2) and the Power Supply Interface Connector (P1). A complete listing of pins and associated signals and voltages for these connectors are listed on the Wiring List in Section VIII, Service, of this manual.

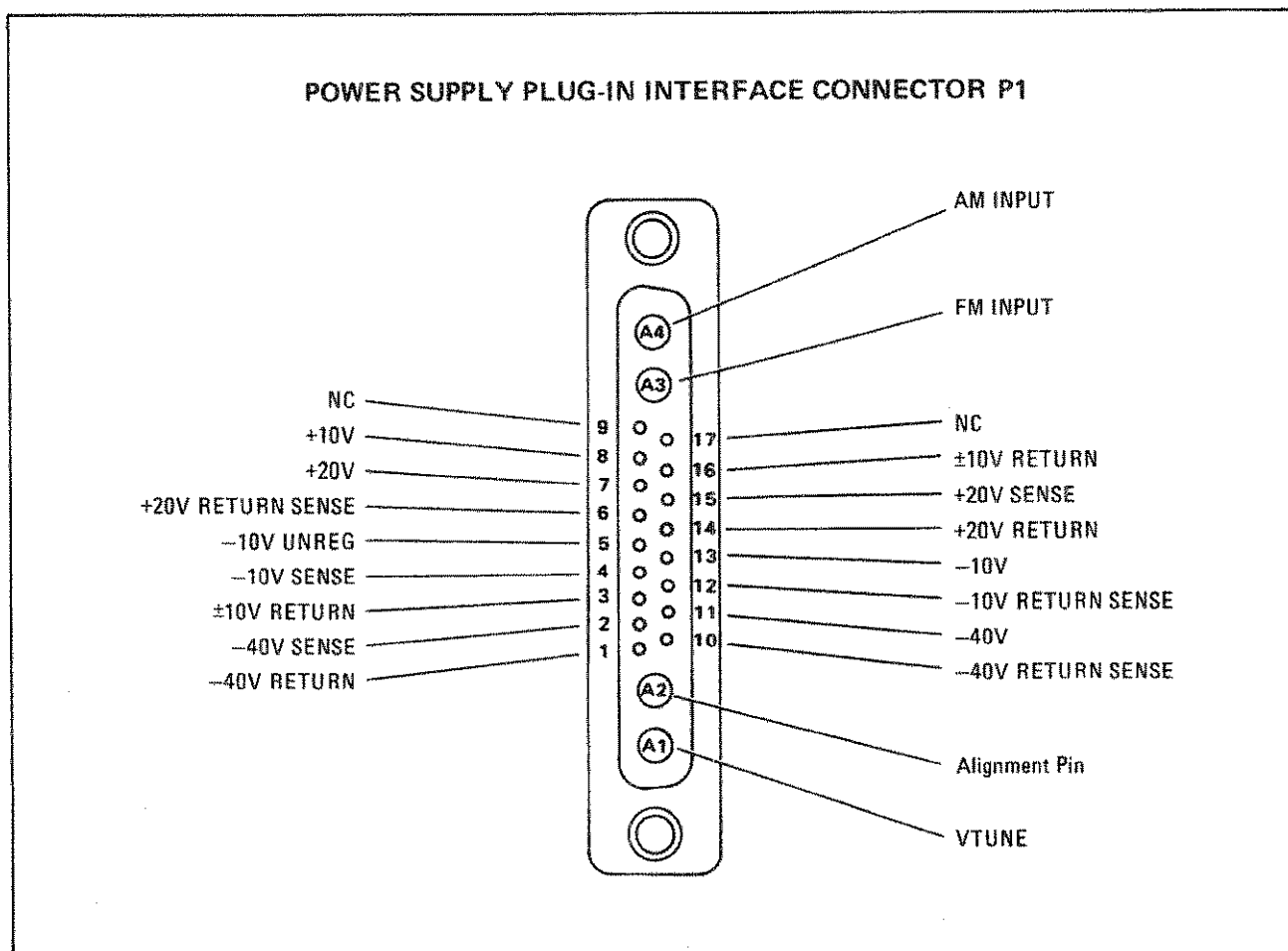

Figure 2-1. Interface Signals on Connector P1

PLUG-IN INTERFACE CONNECTOR P2

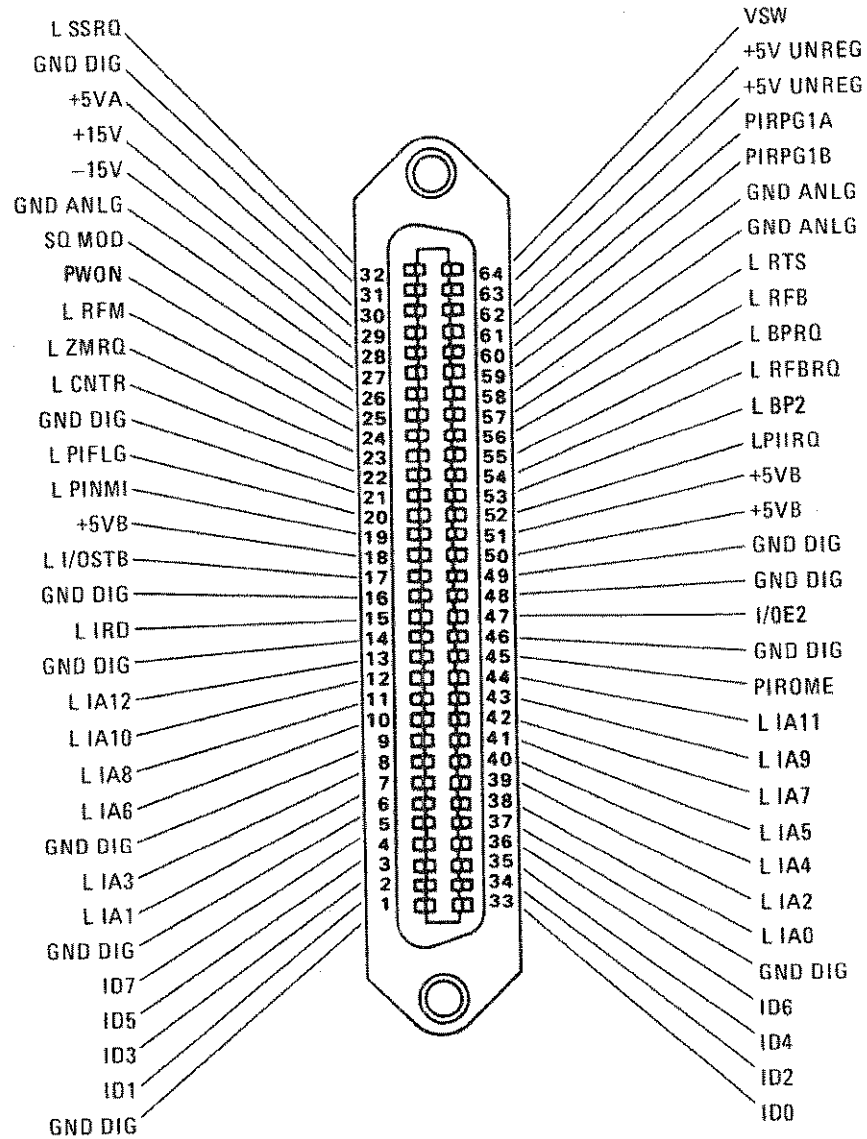

Figure 2-2. Interface Signals on Connector P2

2--12. Mating Connectors

2--13. All of the externally mounted connectors on the Model 83525B are listed in Table 2--1. Opposite each connector is an industry identification, the HP part number of a mating connector, and the part number of an alternate source for the mating connector. For HP part numbers of the externally mounted connectors themselves, refer to Section VI, Replaceable Parts, of this manual.

Table 2-1. Mating Connectors

83525B Connector		Mating Connector	
Connector Name	Industry Identification	HP Part No.	Alternate Source
J1 RF INPUT	TYPE N (f)	1250-0882	Specialty Connector 25-P117-2
J2 EXT/MTR ALC INPUT	BNC (f)	1250-0256	Specialty Connector 25-P118-1
J3 EXT MKR	BNC (f)	1250-0256	Specialty Connector 25-P118-1
J4 IV/GHz	BNC (f)	1250-0256	Specialty Connector 25-P118-1
J5 PULSE IN	BNC (f)	1250-0256	Specialty Connector 25-P118-1

2--14. Operating Environment

2--15. Temperature. The instrument may be operated in temperatures from 0°C to +55°C.

2--16. Humidity. The instrument may be operated in environments with humidity from 5% to 80% relative at +25°C to +40°C. However, the instrument should also be protected from temperature extremes which cause condensation within the instrument.

2--17. Altitude. The instrument may be operated at altitudes up to 4572 meters (approximately 15,000 feet).

2--18. Cooling. When the Model 83525B RF Plug--in is properly installed in the Model 8350A Sweep Oscillator, it obtains all of its

cooling airflow by forced ventilation from the fan in the Model 8350A. A diagram showing the various cooling airflow paths within the sweep oscillator is given in Section II, Installation, of the Model 8350A Sweep Oscillator Operating and Service Manual. Insure that all airflow passages in the Model 8350A and the Model 83525B are clear before installing the RF Plug--in in the Sweep Oscillator.

2--19. Installation Instructions

2--20. To operate as a completely functional sweep oscillator, the Model 83525B RF Plug--in must be installed in a Model 8350A Sweep Oscillator. To install the Model 83525B RF plug--in in the Model 8350A Sweep Oscillator:

- a. Set the Model 8350A mainframe LINE switch to OFF.
- b. Remove all connectors and accessories from the front and rear panel connectors of the Model 83525B to prevent them from being damaged.
- c. Position the RF plug--in unit latching handle in the fully raised position. The latching handle should spring easily into the raised position and be held by spring tension.
- d. Insure that the Model 8350A RF plug--in channel is clear, align the RF plug--in in the channel and slide it carefully into place towards the rear of the channel. It should slide easily without binding.
- e. The drawer latch handle slot will engage with the locking pin just before the RF plug--in is fully seated in position.
- f. Press the latch handle downward, while still pushing in on the RF plug--in, until the drawer latch is fully closed and the front panel of the RF plug--in is aligned with the sweep oscillator front panel.

2--21. STORAGE AND SHIPMENT

2--22. Environment

2--23. The instrument may be stored or shipped in environments within the following limits:

Temperature -40°C to +75°C
Humidity 5% to 95% relative at 0" to +40°C
Altitude Up to 15240 meters
(approximately 50,000 feet)

2--24. The instrument should also be protected from temperature extremes which may cause condensation in the instrument.

2--25. Packaging

2--26. Original Packaging. Containers and materials identical to those used in factory packaging are available through Hewlett--Packard offices. A complete diagram and listing of packaging materials used for the Model 83525B is shown in Figure 2--1. If the instrument is being returned to Hewlett--Packard for servicing, attach a tag indicating the type of service required, return address, model number, and full serial number (located on rear panel serial plate). Mark the container FRAGILE to assure careful handling. In any correspondence, refer to the instrument by model number and full serial number.

2--27. Other Packaging. The following general instructions should be used for repackaging with commercially available packaging materials:

- a. Wrap the instrument in heavy paper or plastic. If shipping to a Hewlett--Packard Office or Service Center, attach a tag indicating the type of service required, return address, model number, and full serial number.
- b. Use a strong shipping container.
- c. Use enough shock--absorbing material around all sides of the instrument to provide a firm cushion and to prevent movement inside the container. Protect the control panel with cardboard.
- d. Seal the shipping container securely.
- e. Mark the shipping container FRAGILE to assure careful handling.
- f. In any correspondence, refer to the instrument by model number and full serial number.

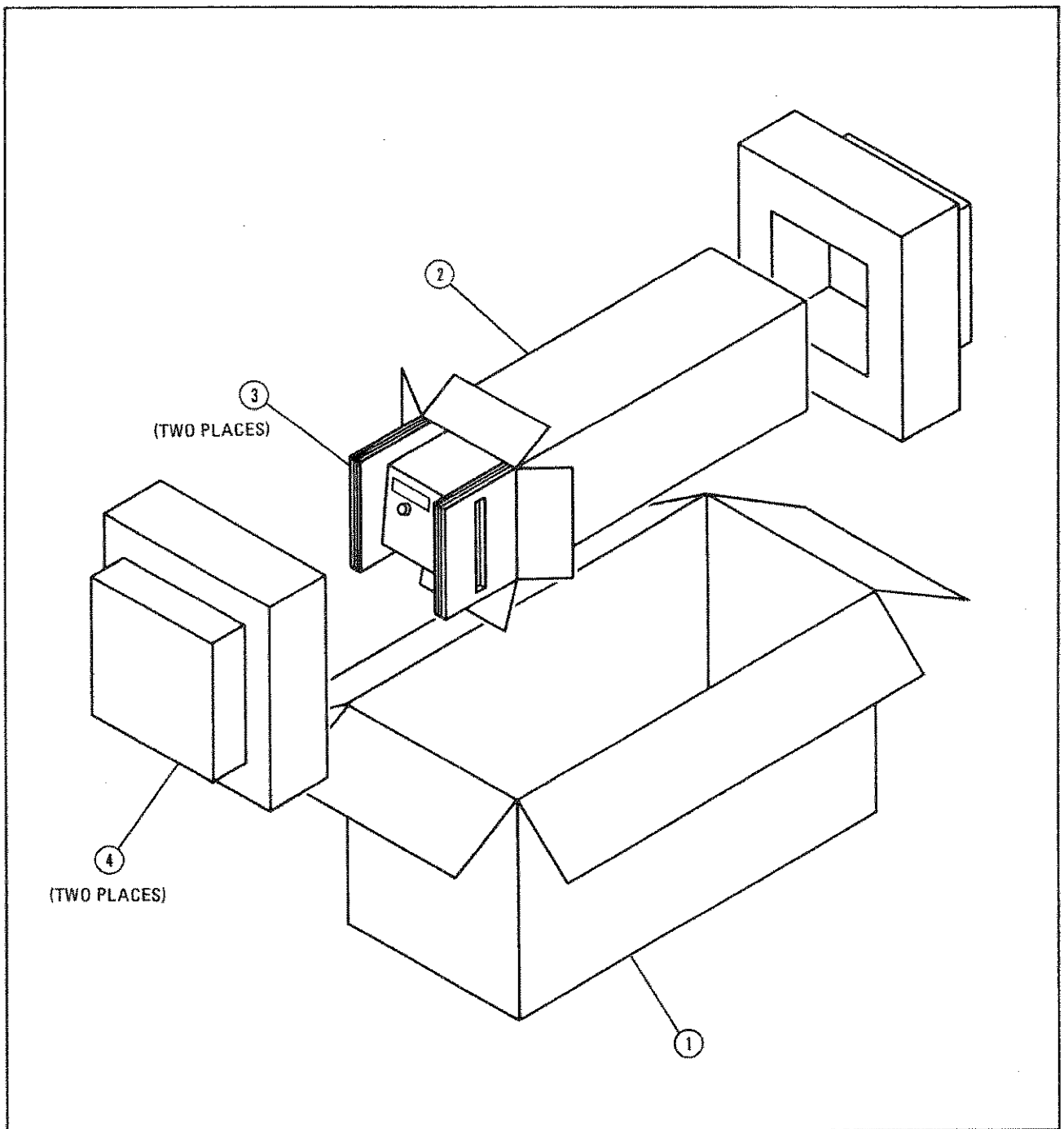

Item	Quantity	HP Part Number	C D	Description
1	1	9211-3515	6	Outer Carton
2	1	9211-3514	5	Inner Carton
3	2	9220-3409	6	Side Pads — Corrugated Cardboard
4	2	9220-3406	3	Foam Pads
	1	9222-0352	6	Poly Bag — to cover instrument

Figure 2-3. Packaging for Shipment Using Factory Packaging Materials

SECTION III

OPERATION

3--1. INTRODUCTION

3--2. This section is divided into four major parts. Operating Characteristics explains the bandswitching and frequency resolution characteristics in continuous wave (CW) and swept modes. Front and Rear Panel Features are shown with descriptions. Operating Instructions provide a front panel frequency calibration procedure, crystal detector and power meter leveling instructions, configuration switch settings, and a phase--locking procedure. Operator's Maintenance includes information on the Plug--In error codes, fuses, and service tags.

3--3. OPERATING CHARACTERISTICS

3--4. Bandswitching and Resolution

3--5. The following paragraphs describe the bandswitching and frequency resolution characteristics of the 83525B RF Plug--In.

3--6. The 83525B 10 MHz to 8.4 GHz RF output is provided in two bands, 10 MHz to 2.1 GHz and 2.0 GHz to 8.4 GHz. When a range of frequencies larger than a single band is swept, the switching between these bands is done automatically. Careful selection of sweep frequencies may avoid problems associated with bandswitching such as harmonics, sweep time, stability, or switching discontinuities. Figure 3--1 illustrates the bandswitching points in the sequential and single band sweep modes.

3--7. Two areas relating to frequency resolution must be considered: these are input resolution and displayed resolution. Input resolution refers to the number of bits (8 bits = 256 points) in the digital to analog converter (DAC) used to generate the tuning voltage for a particular mode of operation. Table 3--1 cross--references input resolution with each DAC used. Displayed frequency resolution refers to the number of digits shown on the 8350A FREQUENCY displays.

Table 3-1. Input Resolution

DAC Used	Voltage Resolution	Frequency Resolution		
		Low Band 0.01 - 2.1 GHz	High Band 2 - 8.4 GHz	Full Sweep 0.01 - 8.4 GHz
CF	2.5 mV	0.530 MHz	1.63 MHz	2.13 MHz
Vernier	40 μ V	8.28 kHz	25.4 kHz	33.2 kHz
ΔF 1--1/8 of band	10 mV	2.12 MHz	6.5 MHz	8.52 MHz
ΔF 1/8 - 1/64 of band	1.25 mV	0.265 MHz	0.81 MHz	1.06 MHz
$\Delta F \leq 1/64$ of band	0.156 mV	33.2 kHz	101.6 kHz	133.1 kHz

3--8. Figure 3--2 is a simplified block diagram of the frequency tuning circuits. The net tuning voltage results from the summation of the three DAC outputs. With this DAC configuration the START/STOP sweep mode is computed by the microprocessor into a center frequency and a Δ F sweep width. Therefore the operation of all sweeps is set with a center frequency and sweep width. The center frequency is specified by the center frequency (CF) DAC and the Vernier DAC, and the sweep width is determined by the Δ F DAC.

3--9. The CF DAC has 12 bits, hence 4096 points across either of the Plug--In frequency bands (including overrange). The analog output ranges from zero to ten volts, which is used to coarsely specify the center frequency output of the Plug--In. These parameters give the CF DAC a resolution of 0.024% (2.5mV) over the full band (including overrange).

3--10. Resolution of Center Frequency is enhanced by a summed voltage generated by an 8--bit (256 points) Vernier DAC. Vernier range is set to $\pm 0.05\%$ of bandwidth (including overrange). In multiband Plug--Ins, total range of the vernier will vary with each band sweep. Vernier resolution is determined by dividing $\pm 0.05\%$ bandwidth by 256 points (128 points on either side of CF). The voltage range of the total 256 points on the Vernier DAC is equal to four points on the 12--bit CF DAC (two points on either side of CF). This increases CF resolution from 0.024% (2.5mV) to 0.00038% (.04mV), and improves the relative accuracy of the CF by a similar factor.

NOTE

When the vernier is adjusted through its zero--point, the CF DAC is incremented or decremented by the total value of the vernier (2 points on the CF DAC). At this time the accuracy of the Center Frequency is again entirely dependent on the CF DAC, 0.005% of bandwidth.

3--11. The Δ F DAC has 10 bits (1024 points). The analog output from this DAC ranges from -5 to +5 volts to produce an even sweep on either side of the center frequency. The Δ F resolution improves with narrower sweep widths. For broad sweeps, the resolution is 0.1% of the full band. Greater resolution is provided for sweep widths less than 1/8 of the full band range. At these sweep widths, the resolution is improved to 0.012% of the full band.

3--12. Center Frequency (CF) is always displayed with 1 MHz

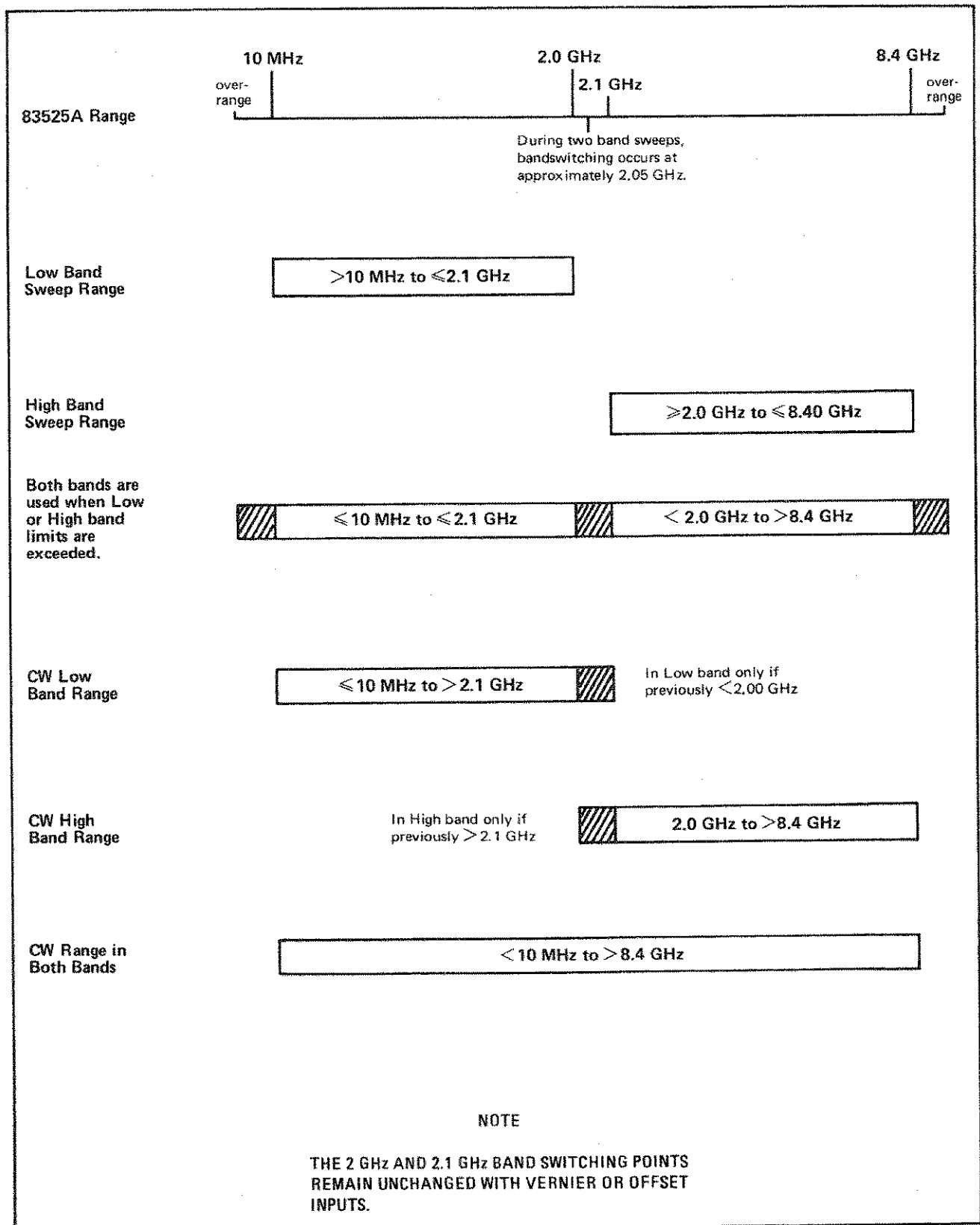

Figure 3-1. Band Switching in CW and Swept Frequency Modes

resolution. Likewise, Vernier values are always displayed at 10 kHz resolution. Display resolutions for ΔF values vary with sweep width. Figure 3--3 illustrates the ΔF mode displayed resolution values versus displayed ΔF frequency sweep widths.

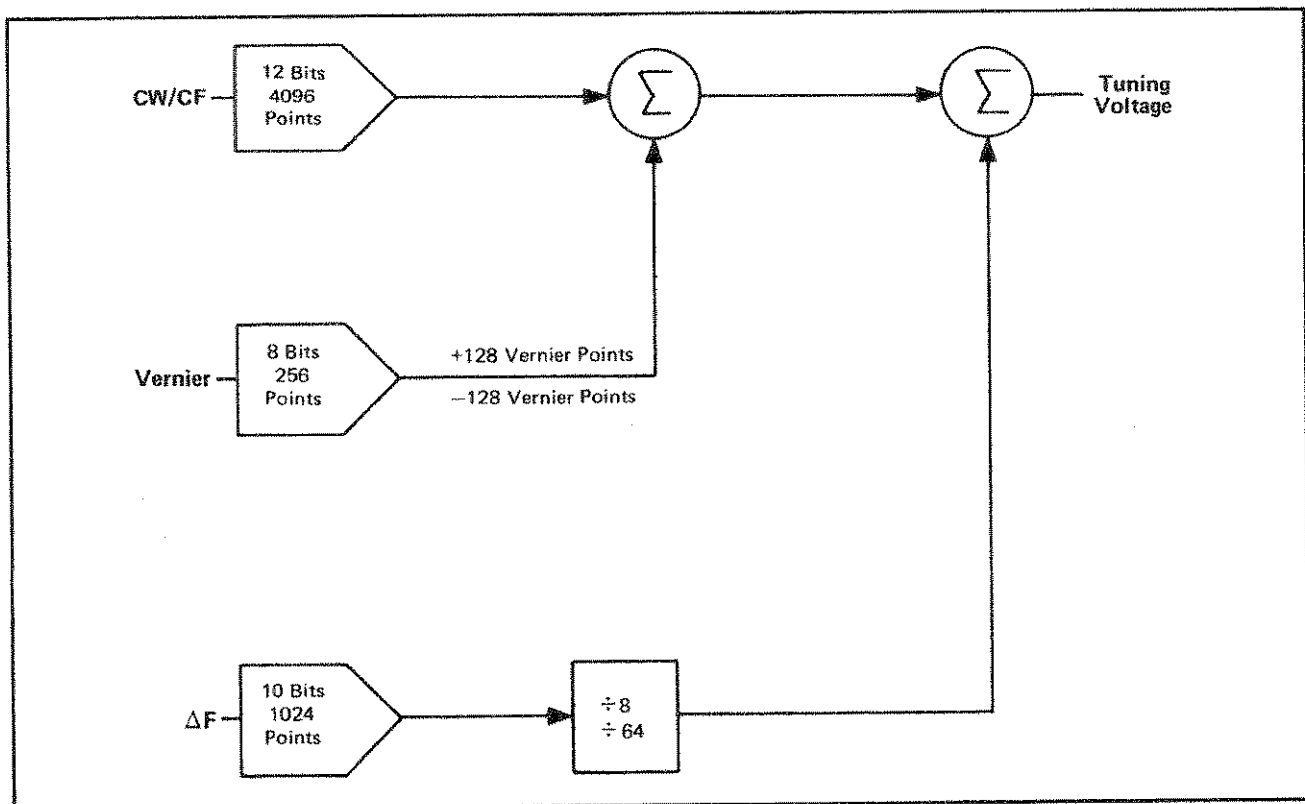

Figure 3-2. Simplified Tuning Voltage Block Diagram

3--14. Front and rear panel features are described in Figures 3--4 and 3--5, respectively. Numbered callouts on the features described match numbered descriptions below each figure.

3--15. OPERATORS CHECKS

3--16. The Operator's Checks portion (Local and Remote) of the 8350A Sweep Oscillator manual provides a quick evaluation of both 8350A and 83525B main functions. Error codes 50 to 99, displayed on the 8350A FREQUENCY display, are reserved to indicate Plug--In related problems. The 8350A Local Check covers the Sweep Oscillator and RF Plug--In. If the correct indications are not obtained, trouble may be in either of the units. If the RF Plug--In is suspected, follow the troubleshooting information in Section VIII, Service, in this manual, to isolate the problem.

		ΔF Display Frequency Width				
		0 MHz	*50 MHz	420 MHz	4.17 GHz	8.4 GHz
Displayed Resolution		*10 kHz	100 kHz	1 MHz	10 MHz	
	ΔF Display Indication	0.00 MHz	0.0 MHz	0 MHz 0.000 GHz	0.00 GHz	

* For Band 0 sweeps only, with $\Delta F \leq 50$ MHz, display resolution increases to 10 kHz. See Figure 3-1 for bandswitch points.

Figure 3-3. Delta F Sweep Mode Displayed Resolution

3--17. OPERATING INSTRUCTIONS

3--18. Front Panel FREQ CAL

NOTE

The 83525B RF Plug--In may not meet the frequency accuracy specifications unless the front panel FREQ CAL (frequency calibration) procedure is performed.

3--19. The front panel FREQ CAL procedure, shown in Figure 3--6, should be performed after the instrument has warmed up for at least one hour. This procedure calibrates the RF output frequency for Band 0 with an external frequency counter.

3--20. Internal Leveling

3--21. The most convenient method of RF output leveling is internal leveling. A portion of the RF output is coupled out of an internal directional detector, producing a DC voltage proportional to the RF output signal. This detected DC voltage is applied to the automatic leveling control circuit (ALC).

3--22. External Crystal Detector Leveling

3--23. RF output power may also be leveled externally using a power

splitter (or external directional coupler) and a negative output crystal detector. This leveling system uses a power splitter to sample a portion of the RF output signal with a crystal detector to produce a DC voltage proportional to the RF output power level. The detector output voltage is compared with an internal reference voltage, and the difference voltage is applied, as modulator drive, to a PIN Modulator which changes the output power level to keep a constant RF output power level. A directional coupler may be used instead of a power splitter to sample the RF signal for the leveling loop. Directional couplers are usually narrow band devices, whereas the power splitter has a flatter frequency response over a wide frequency range. The advantage of a directional coupler is that it does not have as great a coupled loss as the 6 dB loss encountered with the power splitter, therefore a higher maximum leveled output power may be obtained. Figure 3--7 illustrates a typical crystal detector leveling setup.

3--24. External Power Meter Leveling

3--25. RF output power may also be leveled with a power meter and power splitter (or directional coupler) as shown in Figure 3--8. The sweep time is limited to greater than 50 seconds when this leveling method is used. A sample of the RF output signal is routed to a power meter which produces a DC output voltage proportional to the RF input signal level. This DC voltage is applied to the 83525B ALC circuits and compared with an internal reference voltage. A difference voltage is produced and amplified by the ALC amplifier before being applied, as modulator drive, to a PIN Modulator.

3--26. External FM

3--27. The 83525B RF output signal can be frequency modulated using an external modulating signal applied to the 8350A rear panel FM INPUT connector. The external FM function provides a means of obtaining an output frequency that varies under the control of an external modulating signal. A positive--going voltage at the FM INPUT causes the output frequency to decrease, while a negative--going voltage causes the output frequency to increase. The sensitivity and coupling of the modulating signal may be set with configuration switch A3S1. Figure 3--9 lists the available configuration switch settings. The configuration switch settings override 8350A Sweep Oscillator non--volatile memory settings at Instrument Preset.

3--28. External Amplitude Modulation

3--29. Pulse Modulation (PULSE IN Connector on Plug--In). The PULSE IN connector provides pulsed or squarewave modulation, where the RF output is switched on and off. This input provides an on/off power ratio of greater than 30 dB below specified maximum leveled power. The PULSE IN input is normally at a TTL HIGH (approximately +3 volts DC). When a TTL LOW signal (approximately 0 volts DC) is applied, the RF

output is turned off. To get the best pulse modulation performance, the RF output power should be set at +22 dBm. With this power setting, a pulse repetition rate of up to 1 MHz is achievable in the 2.0 to 8.4 GHz frequency band. With leveled power in this band, pulse repetition rates may be up to 100 kHz. In the 0.01 to 2.0 GHz band, RF power may be squarewave modulated at repetition rates up to 30 kHz at any power output setting. The input impedance for TTL level signals is approximately 500 ohms. If the PULSE IN circuit is driven beyond TTL levels, the input impedance is reduced to approximately 200 ohms due to the diode clamping action. See the specifications and supplemental characteristics in Section I for more details on the modulation characteristics when this input is used.

3--30. Amplitude Modulation (AM INPUT Connector on 8350A). The AM INPUT provides linear amplitude changes (up to approximately 15 dB) proportional to the modulating input voltage. It is limited to a frequency response of about 100 kHz. For maximum depth of modulation (i.e. maximum modulation index), the RF power level should be set to the middle of the control range (e.g. +5.5 dBm for a Plug--In with calibrated power control from -2 to +13 dBm). For Plug--Ins equipped with Option 002 (70 dB step attenuator), the middle of the attenuator range should be selected. The center of the power control range may be selected with the front panel power control or by applying a DC bias voltage on the external modulating signal. A positive (+) DC voltage into the AM INPUT causes a decrease in RF output power; a negative (-) DC voltage causes an increase in RF output power.

3--31. RF Power Control

3--32. The RF power set at power--up (during Instrument Preset) may be either maximum leveled power (+13 dBm) or RF power OFF, as selected by the configuration switch (A3S1). Refer to Figure 3--9 for this setting. The configuration switch is encoded prior to operation with information to identify the Model of RF Plug--In installed (83525B), and the Step Attenuator Option 002 if applicable, as well as with certain operator--chosen parameters. Configuration switch settings override 8350A Sweep Oscillator non--volatile memory settings at Instrument Preset. Switch numbers 1, 2, 3, and 7 are set at the factory and should not be changed.

3--33. Option 002 Step Attenuator

3--34. With Option 002 installed, the RF output power may be continuously controlled from maximum leveled output power down to -75 dBm. When the selected power setting goes below -5 dBm, the step attenuator increments as required in 10 dB steps to a maximum attenuation of 70 dB. Within the individual 10 dB steps of the attenuator, the ALC loop adjusts the power output to the power level programmed by the front panel POWER control. Pressing SHIFT POWER

SWEEP allows control of power within the ALC range without changing attenuator settings. The display in the SHIFT POWER SWEEP mode disregards attenuator settings and only displays the ALC setting. Pressing SHIFT SLOPE allows control of attenuator steps without affecting ALC setting. In this mode the attenuator setting is displayed.

3--35. Alternate Sweep Mode with Option 002

3--36. If the Option 002 attenuator is installed, and alternate sweep mode is selected, a slow sweep default condition of 1 second per sweep may occur. This default condition only occurs when the POWER settings of the two alternate sweeps require the attenuator to switch after each sweep. The attenuator is prevented from switching faster than one step per second to prevent damage to the attenuator relay coils due to overheating.

3--37. Phase--Lock Operation

3--38. The RF output signal of the 83525B can be phase--locked to a specified CW frequency using the HP 5344S Microwave Source Synchronizer. The 83525B signal is automatically tuned by the 5344S. Alternatively the 83525B signal can be phase--locked to an external reference oscillator. In either case, the phase--lock signal is applied to the 8350A rear panel FM INPUT connector. The phase--lock function provides a means of obtaining a very stable CW signal by transferring the frequency stability of the 5344S Source Synchronizer or the reference oscillator to the 8350A and eliminating frequency drift. Configuration Switch A3S1 switch position 8 must be set closed (LOW) for phase--lock operation of the 83525B (see Figure 3--9). The CW filter should be turned off in phase--lock operation. Figure 3--10 shows an example of phase--locking the 83525B RF output signal using the 5344S Source Synchronizer and the 779D 2.0 to 8.4 GHz Directional Coupler.

3--39. OPERATOR'S MAINTENANCE

3--40. Plug--In Error Codes

3--41. The 8350A FREQUENCY window will display RF Plug--In error codes (50 to 99) or Sweep Oscillator error codes. Information necessary to interpret Plug--In error codes may be found in Section VIII, Service, in this manual.

3--42. Fuses

3--43. Power circuits for the Model 83525B RF Plug--In are fused in the 8350A Sweep Oscillator. See the 8350A Sweep Oscillator Operating and Service Manual for fuse locations and replacement instructions.

3--44. Blue Service Tags

3--45. If the 83525B RF Plug--In requires service, the instrument may be sent to your local HP service organization as described in Section II, Installation, in this manual. Before sending the instrument back, fill out and attach one of the blue service tags. Record any error codes noted on the failure symptoms/special control settings portion of the tag.

FRONT PANEL FEATURES

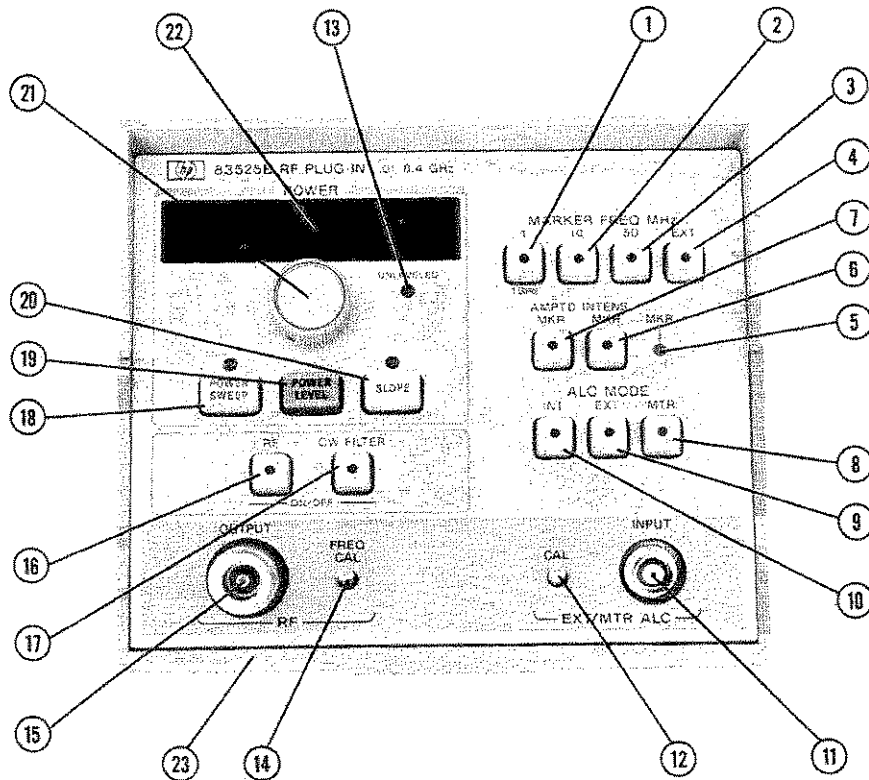

1. 1 MHz Crystal frequency marker enable key.
2. 10 MHz Crystal frequency marker enable key.
3. 50 MHz Crystal frequency marker enable key.
4. External frequency marker enable (input on Plug--In rear panel).
5. MKR lamp indicates when RF output frequency is equal to a marker pulse frequency.
6. Enables Plug--In crystal markers in intensity mode.
7. Enables Plug--In crystal markers in amplitude mode.
8. Power meter automatic leveling control selection (HP 432 only).
9. External (crystal detector) automatic leveling control selection (negative crystal output).
10. Internal leveling control selection.
11. Connector (BNC) for power meter or external crystal leveling inputs (rear panel on Option 004).
12. Power level CAL adjust, for setting external (MTR or EXT) ALC.
13. UNLEVELED lamp lights if output power is unlevelled.

14. Fine frequency adjust used for front panel frequency calibration.
15. Type--N 50--ohm RF OUTPUT connector (rear panel on Option 004).
16. RF ON--OFF key. Used for zeroing a power meter or referencing an X--Y recorder.
17. CW FILTER enables an oscillator tune voltage filter in CW mode.
18. POWER SWEEP allows setting an increase in power per sweep (dB/SWP). SHIFT POWER SWEEP (Option 002) latches the Step Attenuator at its current setting. Power level changes are controlled by the ALC loop.
19. POWER LEVEL allows setting of output power for all ALC modes (may be calibrated for external leveling).
20. SLOPE allows setting of the frequency slope compensation in dB/GHz (for lossy devices). SHIFT SLOPE (Option 002) latches the ALC loop at its current reference level. Power level changes are controlled by the Step Attenuator (10 dB steps).
21. Power control knob for controlling power sweep, power level, or slope.
22. Plug--In display provides readout of selected power mode in dBm, dB/GHz, or dB/SWP to a tenth of a dB/dBm.
23. Plug--In latch handle is used to remove, install, and latch the RF Plug--In in the Sweep Oscillator.

Figure 3--4. Front Panel Features

REAR PANEL FEATURES

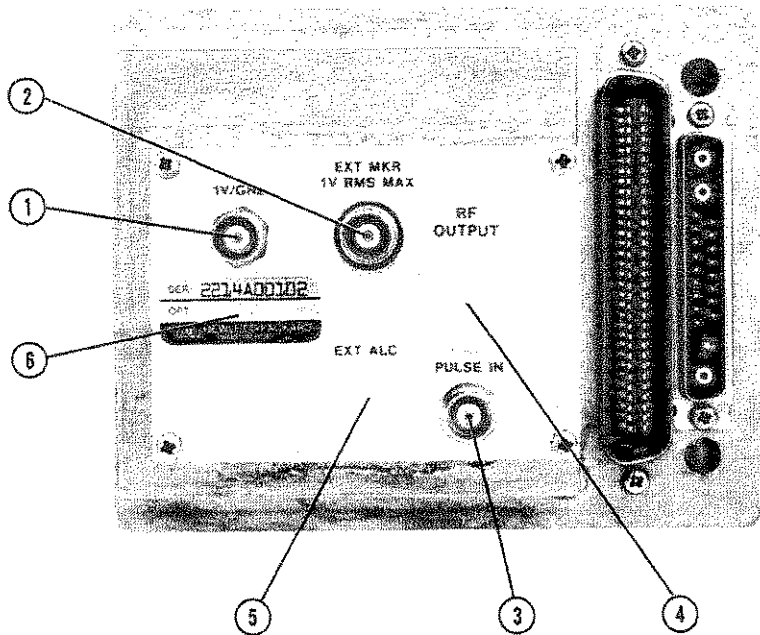

1. 1V/GHz connector provides a frequency reference output of approximately 1 volt DC per GHz.
2. EXT MKR (1V RMS MAX) input connector allows use of external marker when Plug--In EXT marker is engaged.
3. PULSE IN connector is used to input external pulse or squarewave modulation.
4. RF OUTPUT connector replaces front panel RF OUTPUT connector in Option 004 Plug--Ins.
5. EXT ALC connector replaces front panel EXT ALC connector on Option 004 Plug--Ins.
6. Serial number plate has a ten digit serial number (used in any correspondence concerning Plug--In) and Option number if applicable.

Figure 3--5. Rear Panel Features

FREQ CAL PROCEDURE

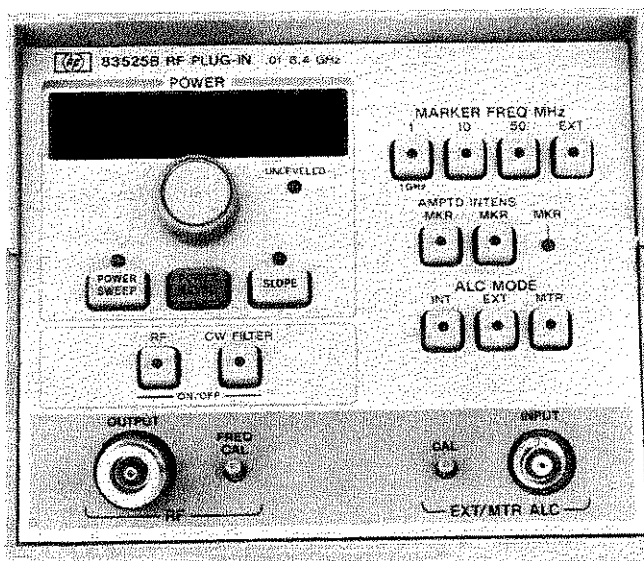

1. Press 8350A INSTR PRESET CW 5 0 MHz .
2. Press 83525B AMPTD MKR (50 MHz switch on automatically).
3. Adjust 83525B FREQ CAL control until MKR lamp is on.
4. Press 8350A 1 0 MHz .
5. Press 83525B 10 MHz Marker .
6. Fine adjust 83525B FREQ CAL control (if necessary) until MKR lamp is on.
7. Press 83525B 1 MHz Marker .
8. A small adjustment of the FREQ CAL control may be needed for the MKR lamp to light.

Figure 3--6. FREQ CAL Procedure

EXTERNAL CRYSTAL DETECTOR LEVELING

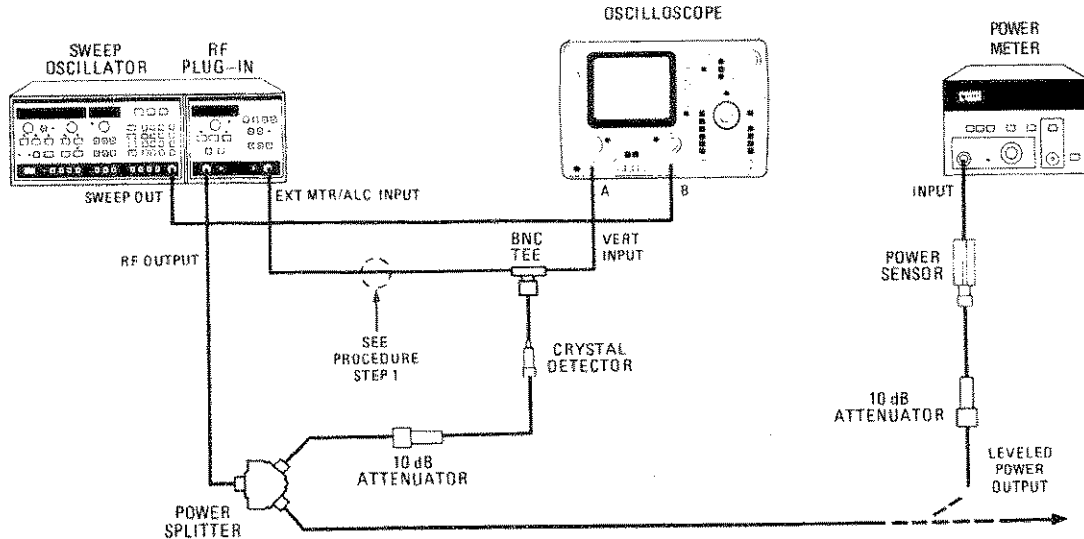

EQUIPMENT:

Sweep Oscillator	HP 8350A
RF Plug--In	HP 83525B
Oscilloscope	HP 1740A
Power Meter	HP 436A
Power Sensor	HP 8482A
Crystal Detector	HP 423B
Power Splitter	HP 11667A
10 dB Attenuator (2 required)	HP 8491A, Option 010
BNC Tee	HP 1250--0781

PROCEDURE:

NOTE

Crystal output signal must be between -10 mVdc and -200 mVdc.

1. Connect equipment as shown in test setup.

Figure 3--7. External Crystal Detector Leveling (1 of 2)

NOTE

Between 10 MHz and 50 MHz RF feedthrough as high as 3 dB may be observed on the envelope of the video output. During external leveling at 10 to 50 MHz, the RF feedthrough may be damped out by insertion into the test setup of the circuit shown below. The circuit may be inserted in the line to the EXT INPUT of the RF Plug--In.

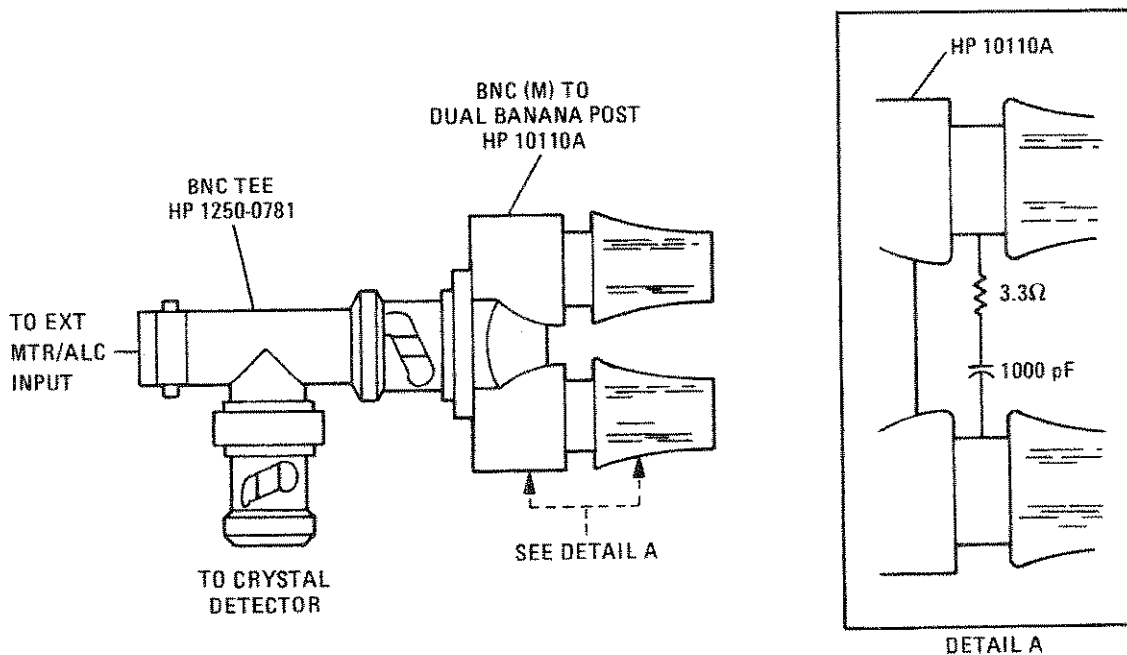

2. Switch on 8350A LINE switch. Press INSTR PRESET key. The START and STOP indicators should be on.
3. Set controls as follows:
 83525B:
 ALC MODE EXT
4. Adjust EXT/MTR ALC CAL for a power meter reading equal to the front panel output power.
5. To use leveled RF output power for testing external equipment, make a connection at the point in the test setup marked "Leveled Power Output".

Figure 3--7. External Crystal Detector Leveling (2 of 2)

EXTERNAL POWER METER LEVELING

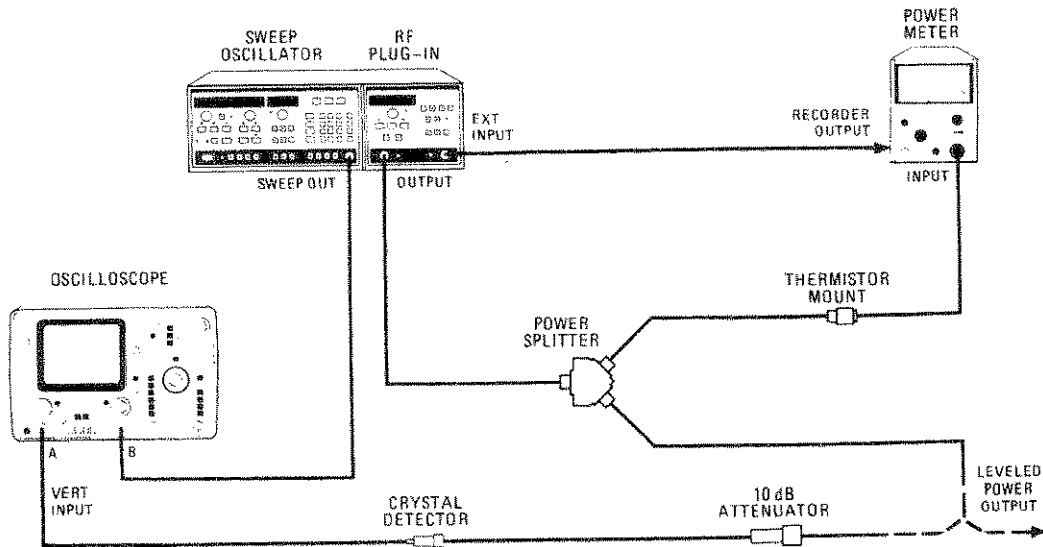

EQUIPMENT:

Sweep Oscillator	HP 8350A
RF Plug--In	HP 83525B
Power Meter	HP 432A
Thermistor Mount	HP 8478A
Oscilloscope	HP 1740A
Crystal Detector	HP 423B
10 dB Attenuator	HP 8491A, Option 010
Power Splitter	HP 11667A

NOTE

For power meter leveling, sweep rates should be slower than 50 sec/sweep to ensure proper leveling due to the slow response of the thermistor mount. The HP 435 and 436 power meters will not power meter level this Plug--In. Only an HP 432 may be used.

PROCEDURE:

1. Connect equipment as shown in test setup.

Figure 3--B. External Power Meter Leveling (1 of 2)

2. Switch on the 8350A LINE power. The START and STOP indicators should light, indicating that the START/STOP mode is selected.

3. Set controls as follows:

8350A: Press INSTR PRESET
SWEEP TIME 50 sec

83525B: Set power to maximum specified.
ALC MODE MTR

4. Select +10 dBm range on power meter.

5. Adjust 83525B EXT/MTR ALC CAL for a +7 dBm reading on the 432A power meter. Press 8350A SWEEP TRIGGER SINGLE key twice to set the single sweep mode and start a sweep.

6. To use leveled RF output power for testing external equipment, make a connection at the point in the test setup marked ``Leveled Power Output``.

Figure 3--8. External Power Meter Leveling (2 of 2)

CONFIGURATION SWITCH SETTINGS

<u>Description</u>	<u>Switch Number</u>							
	<u>1</u>	<u>2</u>	<u>3</u>	<u>4</u>	<u>5</u>	<u>6</u>	<u>7</u>	<u>8</u>
Code for 83525B Plug--In (Note 4)	1	0	1	X	X	X	X	X
RF Power OFF at Instrument Preset	X	X	X	1	X	X	X	X
Maximum RF Power at Instrument Preset	X	X	X	0	X	X	X	X
-6 MHz/V FM Sensitivity	X	X	X	X	1	X	X	X
-20 MHz/V FM Sensitivity	X	X	X	X	0	X	X	X
Direct--Coupled FM (Note 3)	X	X	X	X	X	1	X	X
Cross--Over Coupled FM	X	X	X	X	X	0	X	X
Step Attenuator Option 002 Installed (Note 4)	X	X	X	X	X	X	1	X
No Step Attenuator (Note 4)	X	X	X	X	X	X	0	X
RF OUTPUT Phase Lock	X	X	X	X	X	X	X	0

NOTES

1. Switch Positions
 1 = Switch Open = High
 0 = Switch Closed = Low (Ground)
 X = Don't Care
 * = Varies, 1 if Opt. 002, 0 if no Opt. 002

2. Switch is set at the factory as follows:

Switch No	1	2	3	4	5	6	7	8
Position	1	0	1	0	0	0	*	X

3. When direct--coupled FM is selected, FM sensitivity is -20 MHz/V and switch Number 5 is overridden.

4. Switches 1, 2, 3, and 7 are set at the factory and should not be changed.

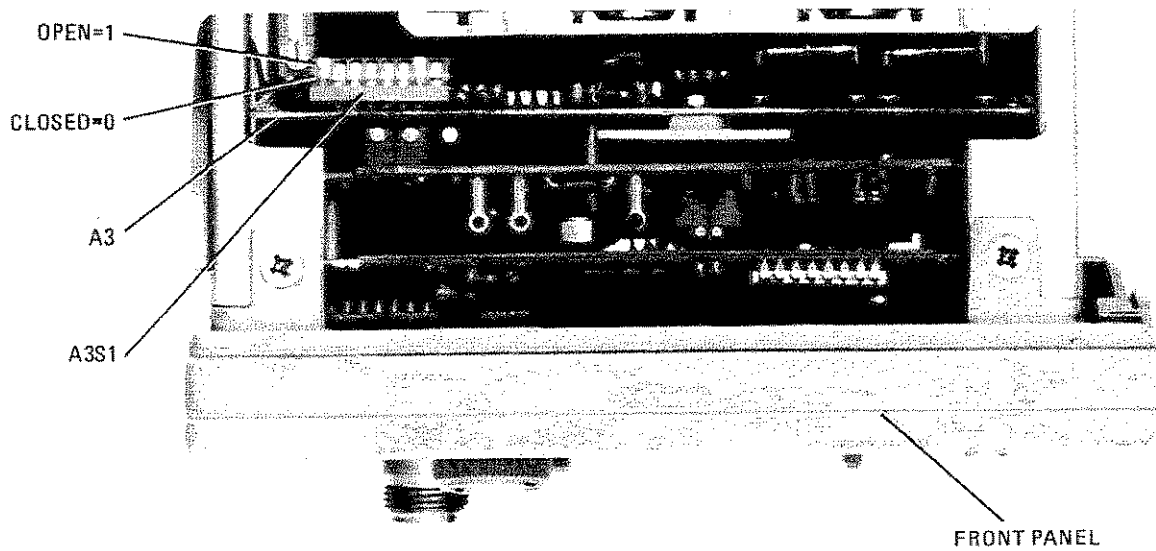
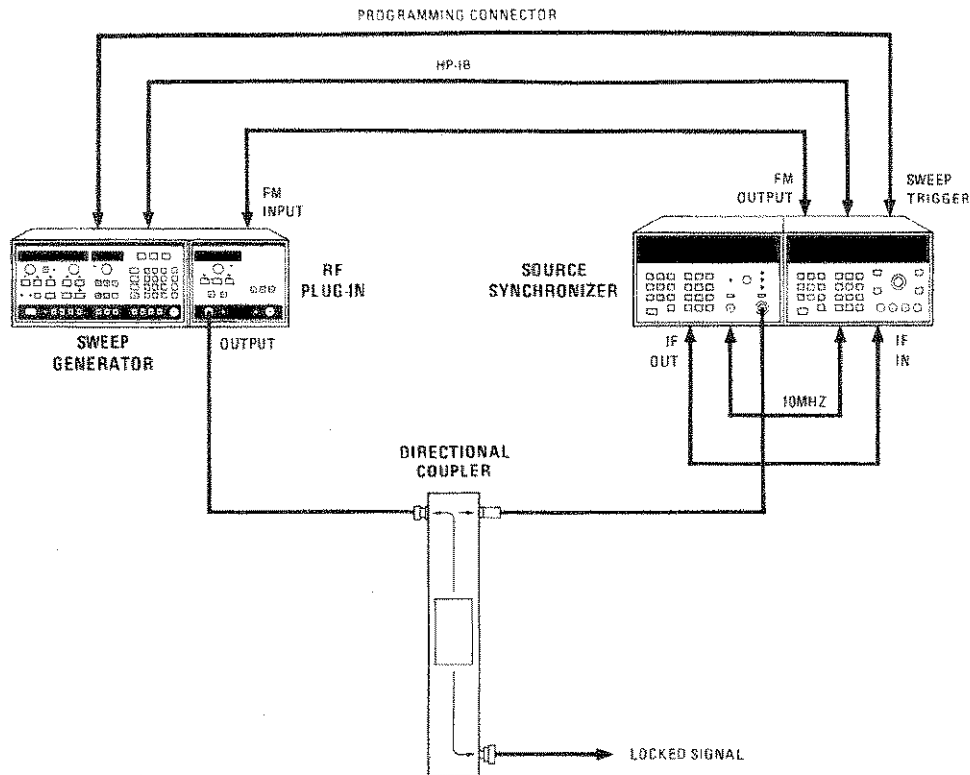

Figure 3--9. Configuration Switch Settings

PHASE--LOCKING USING THE 5344S SOURCE SYNCHRONIZER



EQUIPMENT:

Sweep Oscillator	HP 8350A
RF Plug--In	HP 83525B
Source Synchronizer	HP 5344S
Directional Coupler (2.0 to 8.4 GHz)	HP 779D

DESCRIPTION:

The required CW frequency for the 83525B is automatically tuned and locked by the 5344S, with the 5344S acting as an HP--IB controller. No manual tuning is required. The 8350A Sweep Oscillator and the 5344S Source Synchronizer must be set to the same HP--IB address.

PROCEDURE:

1. Set the 83525B Configuration Switch (A3S1) for an FM Sensitivity of -6 MHz/V, Cross--Over Coupled FM, and front panel RF OUTPUT Phaselock. (See Figure 3--9 for specific

Figure 3--10. Phase--Locking Using the 5344S Source Synchronizer (1 of 2)

settings of A3S1).

2. Connect the equipment as shown in the test setup. Connect the HP--IB connector of the 8350A to the HP--IB connector of the 5344A section of the 5344S.
3. Set the 5344A HP--IB address to 19 (equal to the 8350A) by setting the bottom five switches to 10011.
4. Set the 5344A to the System Controller mode by setting the top HP--IB switch to the left (SYS CONT).
5. On the 8350A press INSTR PRESET .
6. On the 83525B press CW FILTER to turn off the CW filter (pushbutton LED turned off). Set the 83525B Power Level between 0 and +5 dBm.
7. Set the 8350A HP--IB address to 19 if it is not already. Press SHIFT LCL 0 GHz s . The HP--IB address will be shown on the 8350A FREQUENCY/TIME display.
8. On the 5344A, make sure that MANUAL LOCK and AUTO LOCK are both set to off (pushbutton LEDs off). Verify that the front panel CONT lamp is on.
9. Press the 5344A MODE key until the CW annunciator lights. The MODE key will scroll through the four modes of operation. If you pass CW, continue pressing MODE until you return to CW.
10. On the 5344A, enter the frequency required for the 83525B RF output signal.
11. Press the 5344A AUTO LOCK key. The 83525B RF output signal will now be programmed and locked to the specified CW frequency.

Figure 3--10. Phase--Locking Using the 5344S Source Synchronizer
(2 of 2)

SECTION IV

PERFORMANCE TESTS

4-1. INTRODUCTION

4-2. The 83500-series RF plug-ins must be used in conjunction with the 8350A Sweep Oscillator. In order to maintain a high degree of consistency, procedures for testing the electrical performance of the RF plug-ins are found in Section IV of the 8350A Operating and Service Manual. However, information specific to the performance testing of the HP 83525B can be found on the following pages (refer to paragraph 4-6).

4-3. Performance tests unique to this plug-in are also found in this section. None of the tests performed in this section expose the operator to hazardous voltage, nor do they require that any protective covers be removed.

4-4. EQUIPMENT REQUIRED

4-5. Equipment required for testing or adjusting the 83525B is listed in Section I, Table 1-4. Any equipment which satisfies the critical specifications listed in Table 1-4 may be substituted for the recommended model.

4-6. TEST RECORD

4-7. Table 4-2 provides a tabulated index of the performance tests, their acceptable limits, and a column for recording actual measurements.

4-8. The test procedures in Section IV of the 8350A Operating and Service Manual frequently refer the operator to the Test Record Card in this

section. Measurement conditions unique to this plug-in are tabulated under the columns entitled "Step" and "TEST Conditions". The number in the Step column refers to the procedure step in the 8350A manual; the information in the Conditions column corresponds to the instructions given within that step. For example, in the Frequency Accuracy Test, 8350A Operating and Service Manual, step 6 instructs the operator to set CW frequencies at "three points in each band as shown on the test card". The corresponding Step 6 on the test card provides six CW frequencies specifically for the 83525B.

4-9. RELATED ADJUSTMENTS

4-10. If a test offers marginal results, go to Section V and perform the associated adjustment. Table 4-1 correlates adjustments and performance tests.

4-11. CALIBRATION CYCLE

4-12. The performance tests listed in Table 4-2 should be performed in intervals of one year or less.

4-13. OPERATION VERIFICATION

4-14. Operation Verification is a subset of the performance tests, providing reasonable assurance that the 8350A Sweep Oscillator and RF plug-in are operating properly. Paragraph 4-5 in the 8350A Operating and Service Manual specifies these tests and includes an HP-IB Operation Verification program for use with a 9825A/B Desktop Computer.

Table 4--1. Related Adjustments

<u>Performance Test</u> <u>(In 8350A O & S Manual)</u>	<u>83525B</u> <u>Adjustment</u>	<u>8350A</u> <u>Adjustment</u>
<u>4--13. Frequency Range and Accuracy</u> CW Accuracy Swept Frequency Accuracy Marker Accuracy	5--18 5--15 thru 5--20 5--15 thru 5--20	5--19 5--20
<u>4--14. Output Amplitude</u> Power Meter Leveling Power Variations Power Level Accuracy Power Sweep Slope Compensation	5--26 5--22 thru 5--27 5--22 5--25 5--28 5--24	
<u>4--15. Frequency Stability</u>		5--11
<u>4--16. Residual FM</u>		5--11
<u>4--17. Spurious Signals</u>	5--23	
<u>4--19. Residual AM</u>		5--11
<u>4--21. FM Response</u>	5--29	
<u>4--16* Internal Crystal Markers</u>	5--30	
*Refers to paragraph number 4--16 in this 83525B manual.		

4--15. PERFORMANCE TESTS

NOTE

Allow one hour warmup of instrument before attempting the following tests.

4--16. Internal Crystal Markers

SPECIFICATION:

Conditions: RF power level = +3 to +10 dBm; <10 markers/sweep. Harmonic markers of 10 MHz and 50 MHz are available below 2 GHz; 1 MHz harmonic markers are available below 1 GHz. Markers are available as intensity spots or as amplitude dips on the RF output.

DESCRIPTION:

The RF output is detected and displayed on a CRT. Sweep widths are selected to accommodate ten harmonic markers generated by the internal 50 MHz crystal. Both amplitude and intensity markers are verified. The procedure is repeated for 1 MHz and 10 MHz harmonic markers.

EQUIPMENT:

Sweep Oscillator	HP 8350A
Oscilloscope	HP 1740A
Crystal Detector	HP 423B
10 dB Attenuator	HP 8491A OPT. 010

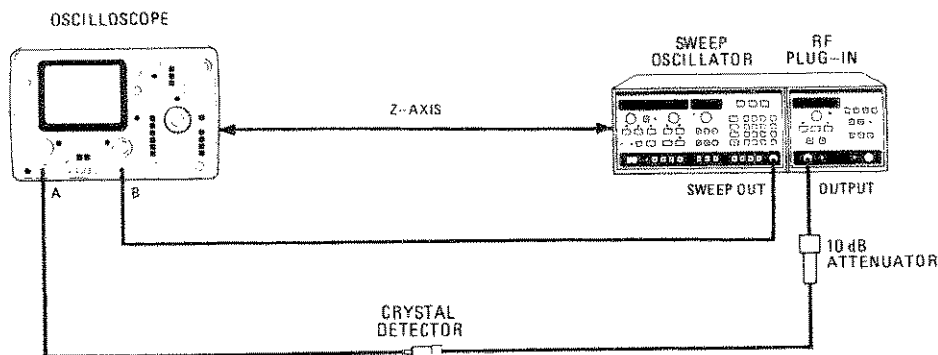

Figure 4--1. Crystal Marker Test Setup

PROCEDURE:

1. Connect equipment as shown in Figure 4--1.
2. Set oscilloscope for A vs B measurement mode. Set Channel B gain at 1V/DIV. Set Channel A gain as necessary.
3. On the 8350A, press INSTR PRESET. Set 83525B power output between +3 and +10 dBm. Adjust oscilloscope POSITION control to center trace on screen.

50 MHz MARKERS

4. Press 8350A CF 2 6 0 MHz . Press ^DF 5 0 0 MHz . On the 83525B select AMPTD MKR and 50 MHz markers.
5. Verify the presence of ten equally spaced and stable markers. Disengage AMPTD MKR and engage INTENS MKR . If necessary, decrease CRT beam intensity to verify that markers are operational as intensity spots.
6. Press 8350A CF . Press 83525B AMPTD MKR . Monitor markers while slowly rotating the left RPG until CF equals 1750 MHz. Verify that amplitude markers are equally spaced and stable across the frequency band.

10 MHz MARKERS

7. On the 8350A, press CF 6 0 MHz . Press ^DF 1 0 0 MHz . On the 83525B, press 10 MHz markers and AMPTD MKR .
8. Verify the presence of ten equally spaced and stable markers.
9. On the 8350A, press CF . Monitor markers while slowly rotating the left RPG until CF equals 1950 MHz. Verify that amplitude markers are equally spaced and stable across the frequency band.

1 MHz MARKERS

10. Press 8350A CF 1 5 MHz . Press ^DF 1 0 MHz . On the 83525B, press 1 MHz markers.
11. Verify the presence of ten equally spaced and stable markers.
12. On the 8350A, press CF . Monitor markers while slowly rotating left RPG until CF equals 995 MHz. Verify that amplitude markers are equally spaced and stable across the frequency band.

Table 4-2. 83525B Performance Test Record Card (1 of 4)

83525B Performance Test Record Card						
NOTE						
Unless otherwise indicated, procedures for the following tests are found in the 8350A Operating and Service Manual.						
Specifications Tested: Limits	Step	Test Conditions	Lower Limit	Measured Value	Upper Limit	
NOTE Perform FREQ CAL adjustment in Section III before proceeding with test.						
4-13. Frequency Range and Accuracy CW Mode 0.01 – 2 GHz: ± 5 MHz 2 – 8.4 GHz: ± 8 MHz Swept Frequency Accuracy 0.01 – 2 GHz: ± 15 MHz 2 – 8.4 GHz: ± 20 MHz 0.01 – 8.4 GHz: ± 25 MHz Marker Accuracy 0.01 – 2 GHz: ± 15 MHz $\pm 0.5\%$ of sweep width 2 – 8.4 GHz: ± 20 MHz $\pm 0.5\%$ of sweep width 0.01 – 8.4 GHz: ± 25 MHz $\pm 0.5\%$ of sweep width						
		4	Start frequency = 10 MHz			10 MHz
		5	Stop frequency = 8.4 GHz	8.4 GHz		
		6	CW frequency = 1.00 GHz	0.995 GHz		1.005 GHz
			CW frequency = 10 MHz	5 MHz		15 MHz
			CW frequency = 2.00 GHz	1.995 GHz		2.005 GHz
			CW frequency = 6.0 GHz	5.992 GHz		6.008 GHz
			CW frequency = 2.1 GHz	2.092 GHz		2.108 GHz
			CW frequency = 8.4 GHz	8.392 GHz		8.408 GHz
		8	Start frequency = 10 MHz	0 MHz		25 MHz
		8A	Start frequency = 1 GHz	985 MHz		1.015 GHz
		9	Stop frequency = 8.400 GHz	8.375 GHz		8.425 GHz
		10	Start frequency = 10 MHz	0 MHz		25 MHz
	10A	Start frequency = 1 GHz	0.985 GHz		1.015 GHz	
		Stop frequency = 2.00 GHz	1.985 GHz		2.015 GHz	
		Start frequency = 2 GHz	1.980 GHz		2.020 GHz	
		Stop frequency = 8.4 GHz	8.380 GHz		8.420 GHz	
	12	Sweep width: 0.01 – 8.4 GHz M1 = 1.00 GHz M2 = 500 MHz* M3 = 100 MHz* M4 = 4.7 GHz M5 = 8.2 GHz * Not used for alternate test method.	0.933 GHz 433 MHz 33 MHz 4.633 GHz 8.133 GHz		1.067 GHz 567 MHz 167 MHz 4.767 GHz 8.267 GHz	
	13	Sweep width: 0.01 – 2 GHz M1 = 1.00 GHz M2 = 1.800 GHz Sweep width: 2–8.4 GHz M1 = 2.5 GHz M2 = 8.0 GHz	0.975 GHz 1.775 GHz 2.448 GHz 7.948 GHz		1.025 GHz 1.825 GHz 2.552 GHz 8.052 GHz	

Table 4-2. Model 83525B Performance Test Record Card (2 of 4)

Specifications Tested: Limits	Step	Test Conditions	Lower Limit	Measured Value	Upper Limit
4-14. Output Amplitude Pwr Mtr Leveled: ± 0.1 dB	9			_____	≤ 0.2 dB
Pwr Lvl Accuracy: ± 1.5 dB	12	Power = +10.0 dBm	+8.5 dBm	_____	+11.5 dBm
Opt. 002: ± 1.7 dB	13	+9.0	+7.5	_____	+10.5
Min. Settable Power: -5 dB		+8.0	+6.5	_____	+ 9.5
Opt. 002: -75 dBm		+7.0	+5.5	_____	+ 8.5
		+6.0	+4.5	_____	+ 7.5
		+5.0	+3.5	_____	+ 6.5
		+4.0	+2.5	_____	+ 5.5
		+3.0	+1.5	_____	+ 4.5
		+2.0	+0.5	_____	+ 3.5
		+1.0	-0.5	_____	+ 2.5
			-1.5	_____	+ 1.5
		-1.0	-2.5	_____	+ 0.5
		-2.0	-3.5	_____	- 0.5
		-3.0	-4.5	_____	- 1.5
		-4.0	-5.5	_____	- 2.5
		-5.0	-6.5	_____	- 3.5
Max Leveled Pwr: +10 dBm	15			_____	+15 dBm
Internal Leveled: ± 1 dB					
Pwr Sweep: ≥ 15 dB/SWP	17	Power level = -2 dBm	≥ 15 dB/SWP	_____	
4-15. Frequency Stability +5 to -10% V Line Change:	2	CW frequency = 1.0 GHz			
0.01 - 8.4 GHz: $\leq \pm 20$ kHz	3	Low line voltage		_____	$\leq \pm 20$ kHz
	4	High line voltage		_____	$\leq \pm 20$ kHz
10 dB Power Change:	9	Power = 10 dBm			
0.01 - 2 GHz: $\leq \pm 100$ kHz	10	CW frequency = 1.0 GHz		_____	$\leq \pm 100$ kHz
2 - 8.4 GHz: $\leq \pm 1$ MHz	11	Reduce power to 0 dBm			
		Power = +10 dBm			
		CW frequency = 4.0 GHz			
		Reduce power to 0 dBm		_____	$\leq \pm 1$ MHz
3 : 1 Load SWR:	13	Power = +10 dBm			
0.01 - 2 GHz: $\leq \pm 10$ kHz	14	CW frequency = 1.3 GHz		_____	≤ 20 kHz
2 - 8.4 GHz: $\leq \pm 250$ kHz	15	CW frequency = 8.4 GHz		_____	≤ 500 kHz
4-16. Residual FM 0.01 - 2 GHz: < 5 kHz	2	CW frequency = 1 GHz		_____	< 5 kHz
2 - 8.4 GHz: < 7 kHz	5			_____	< 7 kHz
	6	CW frequency = 6.0 GHz		_____	< 7 kHz

Table 4-2. Model 83525B Performance Test Record Card (3 of 4)

Specifications Tested: Limits	Step	Test Conditions	Lower Limit	Measured Value	Upper Limit	
4-17. Spurious Signals Harmonic: 0.01 – 2 GHz: ≥ 25 dB 2 – 8.4 GHz: ≥ 45 dB Non-harmonic: 0.01 – 2 GHz: ≥ 30 dB 2 – 8.4 GHz: ≥ 60 dB	3	In dB below carrier	≥ 25 dB ≥ 45 dB ≥ 30 dB ≥ 60 dB	_____		
	6	Range: 0.01 – 2 GHz		_____	<2.0	
	11	Range: 2 – 8.4 GHz		_____	<1.6	
	4-18. Output SWR 0.01 – 2 GHz: <2.0 2 – 8.4 GHz: <1.6	3	Power = +10 dBm CW frequency = 1.0 GHz		_____	
		5	In dB below carrier	≥ 50 dB	_____	
		6	CW frequency = 4.0 GHz	≥ 50 dB	_____	
4-19. Residual AM 0.01 – 8.4 GHz: > 50 dB	3	Power = +10 dBm CW frequency = 1.0 GHz		_____		
	5	In dB below carrier	≥ 50 dB	_____		
	6	CW frequency = 4.0 GHz	≥ 50 dB	_____		
	4-20. External FM Direct coupled: DC – 100 Hz: $\geq \pm 12$ MHz Crossover Coupled: DC – 100 Hz: $\geq \pm 75$ MHz Direct/Crossover coupling: 100 Hz – 1 MHz: $\geq \pm 7$ MHz 1 – 2 MHz: $\geq \pm 5$ MHz 2 – 10 MHz: $\geq \pm 1$ MHz	1	A3S1: Close switch 5, open 6.	$\geq \pm 12$ MHz	_____	
		3			_____	
		4	A3S1: Close switch 6.	$\geq \pm 75$ MHz	_____	
		9		$\geq \pm 7$ MHz	_____	
10			$\geq \pm 5$ MHz	_____		
11	A3S1: Change switch 6 from previous setting.	$\geq \pm 1$ MHz	_____			
11		$\geq \pm 7$ MHz	_____			
11		$\geq \pm 5$ MHz	_____			
11		$\geq \pm 1$ MHz	_____			
11		$\geq \pm 7$ MHz	_____			
11		$\geq \pm 5$ MHz	_____			
11		$\geq \pm 1$ MHz	_____			
4-22. AM On/Off Ratio Square-Wave Symmetry On/Off Ratio: >30 dB below specified max leveled power Symmetry of ON/OFF time: 40/60	1	CW frequency = 1GHz Power = +10 dBm		_____		
	3		>30 dB	_____		
	4		40%	_____	60%	
	5	CW frequency = 4 GHz	>30 dB 40%	_____	_____	60%

Table 4-2. Model 83525B Performance Test Record Card (4 of 4)

Specifications Tested: Limits	Step	Test Conditions	Lower Limit	Measured Value	Upper Limit																																								
4-23. Step Attenuator Accuracy <table border="0"> <tr> <td>Attn. Step</td> <td>Accuracy</td> </tr> <tr> <td>10 dB</td> <td>≤±0.5 dB</td> </tr> <tr> <td>20 dB</td> <td>≤±0.7 dB</td> </tr> <tr> <td>30 dB</td> <td>≤±0.9 dB</td> </tr> <tr> <td>40 dB</td> <td>≤±1.2 dB</td> </tr> <tr> <td>50 dB</td> <td>≤±1.5 dB</td> </tr> <tr> <td>60 dB</td> <td>≤±1.8 dB</td> </tr> <tr> <td>70 dB</td> <td>≤±2.1 dB</td> </tr> </table>	Attn. Step	Accuracy	10 dB	≤±0.5 dB	20 dB	≤±0.7 dB	30 dB	≤±0.9 dB	40 dB	≤±1.2 dB	50 dB	≤±1.5 dB	60 dB	≤±1.8 dB	70 dB	≤±2.1 dB	1	CW frequency = 4.0 GHz Power = +7.0 dBm Ref. Atten. = 70 dB <table border="0"> <tr> <td>Ref Attn Step</td> <td>Attenuator Error</td> <td>Deviation From 0 ref</td> </tr> <tr> <td>70-60</td> <td>_____ +</td> <td>_____</td> </tr> <tr> <td>70-50</td> <td>_____ +</td> <td>_____</td> </tr> <tr> <td>70-40</td> <td>_____ +</td> <td>_____</td> </tr> <tr> <td>70-30</td> <td>_____ +</td> <td>_____</td> </tr> <tr> <td>70-20</td> <td>_____ +</td> <td>_____</td> </tr> <tr> <td>70-10</td> <td>_____ +</td> <td>_____</td> </tr> <tr> <td>70-0</td> <td>_____ +</td> <td>_____</td> </tr> </table>	Ref Attn Step	Attenuator Error	Deviation From 0 ref	70-60	_____ +	_____	70-50	_____ +	_____	70-40	_____ +	_____	70-30	_____ +	_____	70-20	_____ +	_____	70-10	_____ +	_____	70-0	_____ +	_____			
	Attn. Step	Accuracy																																											
	10 dB	≤±0.5 dB																																											
	20 dB	≤±0.7 dB																																											
	30 dB	≤±0.9 dB																																											
	40 dB	≤±1.2 dB																																											
	50 dB	≤±1.5 dB																																											
	60 dB	≤±1.8 dB																																											
	70 dB	≤±2.1 dB																																											
	Ref Attn Step	Attenuator Error	Deviation From 0 ref																																										
70-60	_____ +	_____																																											
70-50	_____ +	_____																																											
70-40	_____ +	_____																																											
70-30	_____ +	_____																																											
70-20	_____ +	_____																																											
70-10	_____ +	_____																																											
70-0	_____ +	_____																																											
	4				≤± 0.5 dB																																								
					≤± 0.7 dB																																								
					≤± 0.9 dB																																								
					≤± 1.2 dB																																								
					≤± 1.5 dB																																								
					≤± 1.8 dB																																								
					≤± 2.1 dB																																								
NOTE The procedure for the following test is found on the pages immediately preceding this test card.																																													
4-16. Internal Crystal Markers (+3 to +13 dBm; ≤10 mkrs/SWP) 50 MHz: 10 Mkrs/SWP, <2 GHz 10 MHz: 10 Mkrs/SWP, <2 GHz 1 MHz: 10 Mkrs/SWP, <1 GHz	5		10 Mkrs/SWP	_____																																									
	6		10 Mkrs/SWP	_____																																									
	8		10 Mkrs/SWP	_____																																									
	9		10 Mkrs/SWP	_____																																									
	11		10 Mkrs/SWP	_____																																									
	12		10 Mkrs/SWP	_____																																									