

User's Guide

HP 8169A Polarization Controller

SERIAL NUMBERS

This guide applies to all instruments.



HP Part No. 08169-91011
Printed in the Federal Republic of Germany

First Edition
E0396

Notices

This document contains proprietary information that is protected by copyright. All rights are reserved.

No part of this document may be photocopied, reproduced, or translated to another language without the prior written consent of Hewlett-Packard GmbH.

© Copyright 1993 by:
Hewlett-Packard GmbH
Herrenberger Str. 130
71034 Boeblingen
Federal Republic of Germany

Subject Matter

The information in this document is subject to change without notice.

Hewlett-Packard makes no warranty of any kind with regard to this printed material, including, but not limited to, the implied warranties of merchantability and fitness for a particular purpose.

Hewlett-Packard shall not be liable for errors contained herein or for incidental or consequential damages in connection with the furnishing, performance, or use of this material.

Printing History

New editions are complete revisions of the guide reflecting alterations in the functionality of the instrument. Updates are occasionally made to the guide between editions. The date on the title page changes when an updated guide is published. To find out the current revision of the guide, or to purchase an updated guide, contact your Hewlett-Packard representative.

Control Serial Number: First Edition applies directly to all instruments.

First Edition : 1st September 1994 : 08169-91011 : E0994
: 1st March 1996 : 08169-91011 : E0396

Warranty

This Hewlett-Packard instrument product is warranted against defects in material and workmanship for a period of one year from date of shipment. During the warranty period, HP will, at its option, either repair or replace products that prove to be defective.

For warranty service or repair, this product must be returned to a service facility designated by HP. Buyer shall prepay shipping charges to HP and HP shall pay shipping charges to return the product to Buyer. However, Buyer shall pay all shipping charges, duties, and taxes for products returned to HP from another country.

HP warrants that its software and firmware designated by HP for use with an instrument will execute its programming instructions when properly installed on that instrument. HP does not warrant that the operation of the instrument, software, or firmware will be uninterrupted or error free.

Limitation of Warranty

The foregoing warranty shall not apply to defects resulting from improper or inadequate maintenance by Buyer, Buyer-supplied software or interfacing, unauthorized modification or misuse, operation outside of the environmental specifications for the product, or improper site preparation or maintenance.

No other warranty is expressed or implied. Hewlett-Packard specifically disclaims the implied warranties of Merchantability and Fitness for a Particular Purpose.

Exclusive Remedies

The remedies provided herein are Buyer's sole and exclusive remedies. Hewlett-Packard shall not be liable for any direct, indirect, special, incidental, or consequential damages whether based on contract, tort, or any other legal theory.

Assistance

Product maintenance agreements and other customer assistance agreements are available for Hewlett-Packard products. For any assistance contact your nearest Hewlett-Packard Sales and Service Office.

Certification

Hewlett-Packard Company certifies that this product met its published specifications at the time of shipment from the factory.

Hewlett-Packard further certifies that its calibration measurements are traceable to the United States National Institute of Standards and Technology, NIST (formerly the United States National Bureau of Standards, NBS) to the extent allowed by the Institutes's calibration facility, and to the calibration facilities of other International Standards Organization members.

ISO 9001 Certification

Produced to ISO 9001 international quality system standard as part of our objective of continually increasing customer satisfaction through improved process control.



Safety Summary

The following general safety precautions must be observed during all phases of operation, service, and repair of this instrument. Failure to comply with these precautions or with specific warnings elsewhere in this manual violates safety standards of design, manufacture, and intended use of the instrument. Hewlett-Packard Company assumes no liability for the customer's failure to comply with these requirements.

General This is a Safety Class 1 instrument (provided with terminal for protective earthing) and has been manufactured and tested according to international safety standards.

Operation - Before applying power Comply with the installation section. Additionally, the following shall be observed:

- Do not remove instrument covers when operating.
- Before the instrument is switched on, all protective earth terminals, extension cords, auto-transformers and devices connected to it should be connected to a protective earth via a ground socket. Any interruption of the protective earth grounding will cause a potential shock hazard that could result in serious personal injury.
- Whenever it is likely that the protection has been impaired, the instrument must be made inoperative and be secured against any unintended operation.
- Make sure that only fuses with the required rated current and of the specified type (normal blow, time delay, etc.) are used for replacement. The use of repaired fuses and the short-circuiting of fuseholders must be avoided.
- Adjustments described in the manual are performed with power supplied to the instrument while protective covers are removed. Be aware that energy at many points may, if contacted, result in personal injury.
- Any adjustments, maintenance, and repair of the opened instrument under voltage should be avoided as much as possible, and when unavoidable, should be carried out only by a skilled person who is aware of the hazard involved. Do not attempt internal service or adjustment unless another person, capable of rendering first aid and resuscitation is present. Do not replace components with power cable connected.
- Do not operate the instrument in the presence of flammable gases or fumes. Operation of any electrical instrument in such an environment constitutes a definite safety hazard.
- Do not install substitute parts or perform any unauthorized modification to the instrument.
- Be aware that capacitors inside the instrument may still be charged even if the instrument has been disconnected from its source of supply.

Safety Symbols

The apparatus will be marked with this symbol when it is necessary for the user to refer to the instruction manual in order to protect the apparatus against damage.

Caution, risk of electric shock.

Frame or chassis terminal.

Protective conductor terminal.

Hazardous laser radiation.

Warning



The WARNING sign denotes a hazard. It calls attention to a procedure, practice or the like, which, if not correctly performed or adhered to, could result in injury or loss of life. Do not proceed beyond a WARNING sign until the indicated conditions are fully understood and met.

Caution



The CAUTION sign denotes a hazard. It calls attention to an operating procedure, practice or the like, which, if not correctly performed or adhered to, could result in damage to or destruction of part or all of the equipment. Do not proceed beyond a CAUTION sign until the indicated conditions are fully understood and met.



Contents

1. Getting Started	
The Basic Operating Principle	1-1
Using the Polarization Controller for Polarization Analysis . . .	1-2
Editing	1-3
Editing Using the Entry Keys	1-3
Editing Using the Modify Keys and Knob	1-3
Resetting Parameters	1-4
2. Setting a State of Polarization	
Setting up the Hardware	2-1
Setting the Position of the Polarizing Filter	2-1
Setting the State of Polarization	2-3
Positioning the $\lambda/4$ and $\lambda/2$ Retarder Plates	2-4
Using the Circle Mode	2-4
Example: Setting the Optimum Transmission SoP	2-4
Set the Polarizing Filter	2-5
Setting the Worst Case Transmission SoP	2-6
Setting the Optimum Transmission SoP	2-7
3. Scanning the Poincare Sphere	
Setting up the Hardware	3-1
Setting Up and Executing a Scan	3-1
Example: Measuring the Response to a “Depolarized” Signal . .	3-2
Set the Polarizing Filter	3-3
Setting Up the Instruments	3-4
Running the Scan	3-4
Example: Measuring a Polarization Dependent Loss	3-5
Set the Polarizing Filter	3-6
Setting Up the Instruments	3-7
Running the Scan	3-7
Analyzing the Results	3-7

4. Other Front Panel Functions	
Setting the HP-IB Address	4-1
Storing or Recalling Instrument Settings	4-1
Storing a Setting	4-1
Recalling a Setting	4-2
Resetting the Instrument	4-2
5. Programming the Polarization Controller	
HP-IB Interface	5-1
Setting the HP-IB Address	5-3
Returning the Instrument to Local Control	5-3
How the Polarization Controller Receives and Transmits Messages	5-3
How the Input Queue Works	5-3
Clearing the Input Queue	5-4
The Output Queue	5-4
The Error Queue	5-4
Some Notes about Programming and Syntax Diagram Conventions	5-4
Short Form and Long Form	5-5
Command and Query Syntax	5-5
6. Remote Commands	
Command Summary	6-2
The Common Commands	6-5
Common Status Information	6-5
SRQ, The Service Request	6-6
*CLS	6-7
*ESE	6-7
*ESE?	6-8
*ESR?	6-8
*IDN?	6-9
*OPC	6-10
*OPC?	6-10
*RCL	6-10
*RST	6-11
*SAV	6-11
*SRE	6-12
*SRE?	6-12
*STB?	6-13
*TST?	6-13
*WAI	6-14
Switching On and Off the Instrument Display	6-15

:DISPlay:ENABle	6-15
:DISPlay:ENABle?	6-15
Positioning the Polarizing Filter	6-16
[:INPut]:POSItion:POLArizer	6-16
[:INPut]:POSItion:POLArizer?	6-16
Setting the State of Polarization	6-17
[:INPut]:CIRClE:EPSilonb	6-17
[:INPut]:CIRClE:EPSilonb?	6-17
[:INPut]:CIRClE:THETap	6-18
[:INPut]:CIRClE:THETap?	6-18
[:INPut]:POSItion:HALF	6-19
[:INPut]:POSItion:HALF?	6-19
[:INPut]:POSItion:QUARter	6-19
[:INPut]:POSItion:QUARter?	6-20
Scanning the Sphere	6-21
[:INPut]:PSPHere:RATE	6-21
[:INPut]:PSPHere:RATE?	6-21
:INITiate[:IMMediate]	6-21
:ABORt	6-21
STATus Commands	6-23
Setting Up the STATus Registers	6-24
:STATus:PRESet	6-24
:STATus:OPERation:NTRansition	6-25
:STATus:OPERation:NTRansition?	6-25
:STATus:OPERation:PTRansition	6-25
:STATus:OPERation:PTRansition?	6-25
:STATus:OPERation:ENABle	6-25
:STATus:OPERation:ENABle?	6-26
:STATus:QUEStionable:NTRansition	6-27
:STATus:QUEStionable:NTRansition?	6-27
:STATus:QUEStionable:PTRansition	6-27
:STATus:QUEStionable:PTRansition?	6-27
:STATus:QUEStionable:ENABle	6-27
:STATus:QUEStionable:ENABle?	6-28
Checking the Status	6-29
:STATus:OPERation:CONDition?	6-29
:STATus:OPERation[:EVENT]?	6-29
:STATus:QUEStionable:CONDition?	6-30
:STATus:QUEStionable[:EVENT]?	6-30
SYSTem Commands	6-31
:SYSTem:ERRor?	6-31

:SYSTem:VERSion?	6-31
7. Programming Examples	
Example 1 - Checking Communication	7-2
Example 2 - Status Registers and Queues	7-3
Example 3 - Finding the Optimum Transmission SoP	7-7
Example 4 - Finding the Polarization Dependence	7-11
A. Installation	
Safety Considerations	A-1
Initial Inspection	A-1
AC Line Power Supply Requirements	A-2
Line Power Cable	A-2
Replacing the Fuse	A-4
Replacing the Battery	A-5
Operating and Storage Environment	A-5
Temperature	A-6
Humidity	A-6
Altitude	A-6
Installation Category and Pollution Degree	A-6
Instrument Positioning and Cooling	A-6
Switching on the Polarization Controller	A-7
Optical Output	A-7
Trigger Input and Output	A-8
HP-IB Interface	A-8
Connector	A-9
HP-IB Logic Levels	A-9
Claims and Repackaging	A-10
Return Shipments to HP	A-10
B. Accessories	
Instrument and Options	B-1
HP-IB Cables and Adapters	B-1
Connector Interfaces and Other Accessories	B-2
Option 021, Straight Contact Connector	B-2
Option 022, Angled Contact Connector	B-3

C. Specifications	
Specifications	C-1
Other Specifications	C-3
Declaration of Conformity	C-4
D. Performance Test	
Insertion Loss Variation with Rotation of $\lambda/4$ and $\lambda/2$ Plates . . .	D-2
Insertion Loss versus Wavelength	D-5
Extinction Ratio of Polarizer	D-10
E. Cleaning Procedures	
Cleaning Materials	E-1
Cleaning Fiber/Front-Panel Connectors	E-2
Cleaning Connector Interfaces	E-2
Cleaning Connector Bushings	E-3
Cleaning Detector Windows	E-3
Cleaning Lens Adapters	E-3
Cleaning Detector Lens Interfaces	E-4
F. Error Messages	
Display Messages	F-1
HP-IB Messages	F-2
Command Errors	F-2
Execution Errors	F-5
Device-Specific Errors	F-6
Query Errors	F-7

Index

Figures

6-1. Common Status Registers	6-6
6-2. The Status Registers	6-24
A-1. Line Power Cables - Plug Identification	A-2
A-2. Rear Panel Markings	A-4
A-3. Releasing the Fuse Holder	A-4
A-4. The Fuse Holder	A-5
A-5. Correct Positioning of the Polarization Controller	A-7
A-6. HP-IB Connector	A-9
B-1. Straight Contact Connector Configuration	B-2
B-2. Angled Contact Connector Configuration	B-3
D-1. Test Setup for Measuring the Insertion Loss	D-2
D-2. Test Setup for Measuring the Reference Power	D-7
D-3. Test Setup for Measuring the Extinction Ratio	D-10

Tables

5-1. HP-IB Capabilities	5-2
6-1. Common Command Summary	6-2
6-2. Command List	6-3
6-3. Reset State (Default Setting)	6-11
A-1. Temperature	A-6
D-1. Equipment used:	D-1

Getting Started

This chapter describes the basic operating principle, and the basic operating of the polarization controller.

The Basic Operating Principle

The HP 8169A Polarization Controller transforms polarization relative to a built in linear polarizer.

This means that the optical input is passed through a linear polarizer (Pol), to extract a single linear polarization.

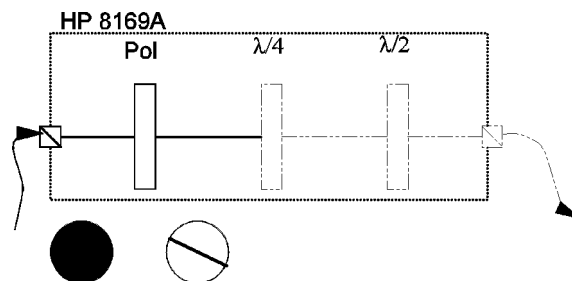

Block Diagram and Polarization States (non-polarized → linear polarized)

You should position this plate to get the maximum from the incoming signal (attach a power meter to the output, and set the angle).

The $\lambda/4$ and the $\lambda/2$ plates are then positioned to control the relative state of polarization of this signal.

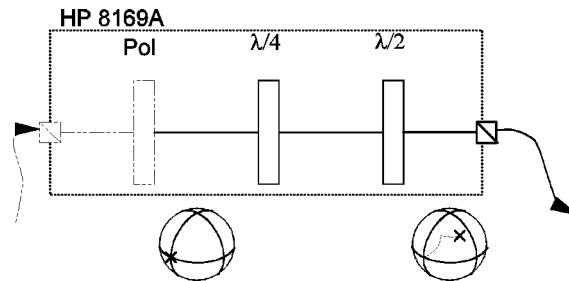

Block Diagram and Polarization States (linear polarized → elliptically polarized)

You can either set the position of the plates directly, or use the circle application to set the $2\varepsilon_B$ and $2\theta_P$ angles that define the position on the Poincaré Sphere.

In addition, using the sphere application, you can vary the angles of the $\lambda/4$ and the $\lambda/2$ plates continuously. By varying the plate positions slowly, and sampling the response of your Device Under Test, you can find the maximum and minimum power levels, and thus make polarization dependent measurements. By varying the plate positions quickly, and averaging over all the states of polarization, you can measure the response of your DUT to a “depolarized” signal.

Using the Polarization Controller for Polarization Analysis

It is also possible to use the polarization controller to analyze the polarization of a signal. To do this you attach your incoming signal to the $\lambda/2$ connector, and attach your power meter to the Pol connector.

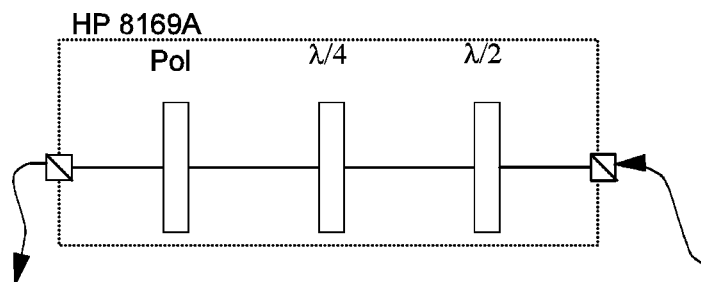

Block Diagram for Polarization Analysis

You analyze the signal by varying the $\lambda/4$ and $\lambda/2$ plates and the polarizer filter, and examining how this affects the power. It is beyond the scope of this manual to explain this topic in detail.

Editing

You can edit a parameter by using

- the Entry keys,
- the Cursor/Vernier keys, or
- the Modify knob.

Editing Using the Entry Keys

1. Make sure the correct parameter is selected (the label of the selected parameter is displayed inverse).
2. Type in the new value.
3. Press **Enter**.

If you mistype the number, you can move the cursor left and right using the Cursor keys (**←** and **→**).

If you want to abort editing, without changing the parameter, press **Cancel**.

If the parameter changes back to its old value when you press **Enter**, then the new value would be out of the range allowed for that parameter.

Editing Using the Modify Keys and Knob

1. Make sure the correct parameter is selected (the label of the selected parameter is displayed inverse).
2. Press any of the Cursor/Vernier keys, to activate editing.
3. Use the Cursor keys (**←** and **→**) to move to the first digit you want to edit.
4. Change the value using the Vernier keys (**↑** and **↓**).
OR
Change the value using the Modify knob.

1

5. Repeat steps list item 3 to list item 4 as often as necessary.
6. Press **Enter**.

If you want to abort editing, without changing the parameter, press **Cancel**.

If you cannot change a digit with the Vernier keys or the Modify knob, this means that the new value would be out of the range allowed for the parameter.

Resetting Parameters

To reset any parameter

1. Make sure the correct parameter is selected (the label of the selected parameter is displayed inverse).
2. Press **Default**.

To reset P_{o1} , $\lambda/4$, $\lambda/2$, $2\varepsilon_B$, AND $2\theta_P$ simultaneously, press **Home**.

Setting a State of Polarization

This chapter describes the two ways of setting a State of Polarization,

- By positioning the polarizing filter, the $\lambda/2$, and the $\lambda/4$ plates.
- By positioning the polarizing filter, and then specifying the desired position on the Poincare sphere.

Setting up the Hardware

Note

When you are setting up your hardware, it is absolutely vital that the fibers are fixed, and remain unmoved for the whole of the measurement. Moving the fibers changes the state of polarization.

Typically, you will connect the polarization controller directly after your source, and before your device under test (DUT). Before connecting to the rest of your measurement setup, you should set the position of the polarizing filter.

Setting the Position of the Polarizing Filter

The polarizing filter should be set to maximize the signal. This means aligning the polarizing filter with the greatest linear polarization of the source. (Light from laser sources is elliptically polarized).

2

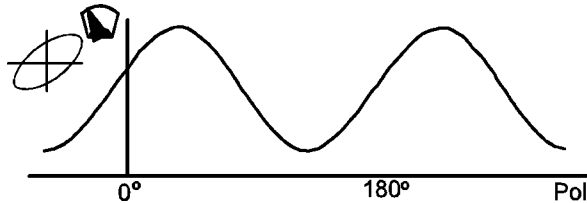

Power as a function of the angle of linear polarization for laser light

1. Connect the output of the polarization controller to a power meter.

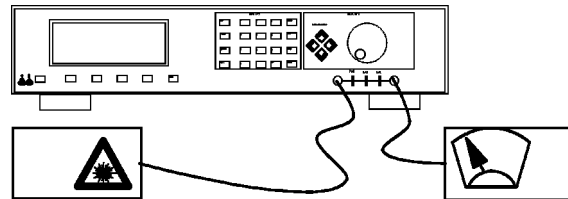

Setup for maximizing the test signal

2. With all the instruments turned on, press **Home** on the polarization controller. This resets the positions of all the plates.
3. Select the polarization filter. You may need to press **Pos** and/or **Pol** if the filter is not already selected.
4. Move the filter to find the maximum signal through the polarization controller. One way of doing this is
 - a. Press the right Cursor key twice to select the units digit.
 - b. Watching the power meter, and using the Modify knob, adjust the angle of the polarization filter, until you are in the area of one of the maxima.
 - c. Select the tenths digit.
 - d. Watching the power meter, and using the Modify knob, adjust the angle of the polarization filter, until you find the maximum.
 - e. Select the hundredths digit, and adjust the angle of the polarization filter if necessary to get the absolute maximum.

2-2 Setting a State of Polarization

5. Disconnect the power meter, and connect to your DUT, and the rest of your measurement setup, making sure to move the fibers as little as possible.

Setting the State of Polarization

The state of polarization of a signal can be described by a position on the Poincare sphere. This position can be expressed in spherical coordinates by two angles, called ε_B and θ_P .

- θ_P is the optical angle about the 'equator' of the sphere (that is, $2\theta_P$ is the angle of 'longitude').
- ε_B is half the angle of elevation from the equatorial plane (that is, $2\varepsilon_B$ is the angle of 'latitude').

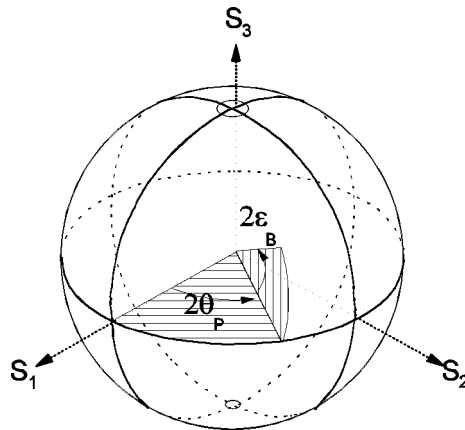

The coordinates for describing the state of polarization

The state of polarization is always relative to the output from the polarizing filter.

There are two ways of setting the state of polarization,

- by specifying the position of the $\lambda/4$ and $\lambda/2$ retarder plates, or
- by specifying ε_B and θ_P , the coordinates on the Poincare sphere.

Positioning the $\lambda/4$ and $\lambda/2$ Retarder Plates

You can set the state of polarization by positioning the $\lambda/4$, and $\lambda/2$ plates.

1. Select a retarder plate. You may need to press (Pos) first to get the display with the plates.
Press $\lambda/4$ or $\lambda/2$ if the plate you want is not already selected.
2. Move the plate to the position you want. (See “Editing” in Chapter 1 if you need information on changing the angles).

Using the Circle Mode

You can set the state of polarization by specifying the coordinates on the Poincare sphere. See “Setting the State of Polarization” for an explanation.

1. Select an angle. You may need to press (Circle) first to get the display with the angles.
Press $2\varepsilon_B$ or $2\theta_P$ if the angle you want is not already selected.
2. Change the angle to the value you want. (See “Editing” in Chapter 1 if you need information on changing the angles).

Example: Setting the Optimum Transmission SoP

To find the state of polarization which gives optimum transmission for a linear device under test (DUT), the steps are

- i. Set the polarizing filter.
- ii. Find the state of polarization for worst case transmission (this is easier to find, because the resolution allows greater accuracy at lower power).
- iii. Set the state of polarization for optimum transmission.

For this example, you will need, apart from the polarization controller, a laser source, and a power meter (in the description below, an HP 8153A Multimeter with a laser module and a sensor module are used). We will use the length of fiber connecting the instruments as our linear DUT.

1. With both instruments switched off, connect the laser source to the polarization controller.
2. Connect the polarization controller to the power meter.

2.4 Setting a State of Polarization

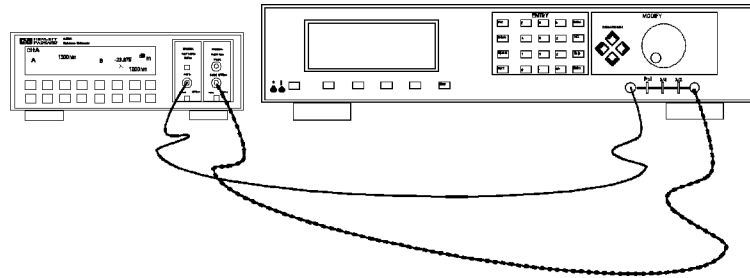

Setup for setting the position of the polarizing filter.

3. Switch on both instruments, and enable the laser source.
4. Set the channel with the sensor module to the wavelength of the source, and select the default averaging speed (200ms).

Note



Under normal circumstances you should leave the instruments to warmup. (The multimeter needs around 20 minutes to warmup.) Warming up is necessary for accuracy of the sensor, and the output power of the source.

Set the Polarizing Filter.

5. Press **(Home)** on the polarization controller.
6. Press **(Pos)**.
7. Set the angle of the polarizing filter for maximum throughput.
 - a. Type in 10 and press **(Enter)**.
 - b. Press **(⇒)** twice to select the tens digit.
 - c. Using the Modify knob, increase the angle slowly until the power read on the multimeter increases and then starts to decrease.
 - d. Press **(⇒)** once to select the units digit.
 - e. Using the Modify knob, decrease the angle slowly until the power read on the multimeter starts to decrease.
 - f. Press **(⇒)** twice to select the hundredths digit.

2

- g. Using the Modify knob, increase the angle slowly until the power on the multimeter starts to decrease. Return to the angle that gave the maximum power.

Setting the Worst Case Transmission SoP. We set the state of polarization for the worst case transmission, because we can find this more accurately (the resolution of the power meter stays the same, but the full scale value is lower, therefore we can be more accurate).

We also use the fact that the relationship between power of the signal transmitted through the DUT and polarization on the surface of the sphere can be expressed as concentric circles about the worst case (or optimum), and that for a linear DUT the worst case and optimum are on opposite sides of the sphere.

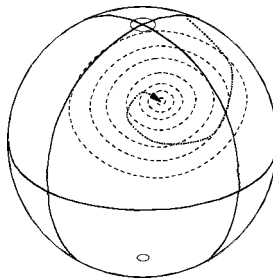

Power contours about the worst case on the poincare sphere

This means that we find the worst case position by moving around the sphere along the equator first (that is finding the angle of longitude of the worst case) and then the overall worst case by moving around this line of longitude.

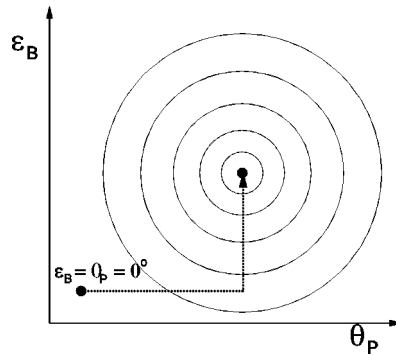

Power contours with a search path to the worst case transmission state of polarization

8. Press **(Circle)**, and **θ_P**, to select θ_P .
9. Search for the line of longitude with the minimum power (use a similar method as for the position of the polarizing filter; first changing the tens, then the units, then the hundredths).
10. Press **ε_B**, to select ϵ_B .
11. Search for the angle of latitude with the minimum power.

Setting the Optimum Transmission SoP.

12. Read the value for ϵ_B from the display.
13. Add 180° to this value.
14. Type in the new value, and press **(Enter)**.

The state of polarization is now set to the value for the current setup that gives the greatest power through the fiber. This is possible here because the fiber behaves linearly. For non-linear components the polarizations for worst case and optimum transmission will not be on opposite sides of the sphere, and the angle between them is a characteristic of the component.



Scanning the Poincare Sphere

3

This chapter describes how you can use your polarization controller to measure polarization dependence, and how you can generate quasi-depolarized signals.

Setting up the Hardware

Note

When you are setting up your hardware, it is absolutely vital that the fibers are fixed, and remain unmoved for the whole of the measurement. Moving the fibers changes the state of polarization.

Typically, you will connect the polarization controller directly after your source, and before your device under test (DUT). Before connecting to the rest of your measurement setup, you should set the position of the polarizing filter (this is described in “Setting the Position of the Polarizing Filter” in Chapter 2).

Setting Up and Executing a Scan

The sphere application changes the state of polarization over time, by rotating the $\lambda/2$ and $\lambda/4$ plates. The rotations can be done slowly, to give a quasi-randomly polarized signal, which you can use, with suitable data logging to measure polarization dependence. The rotations can be done quickly, to give a quasi-depolarized signal, which you can use, with suitable measurement averaging time to measure depolarized response.

1. Press **Sphere** to select the application.

Note

The Pol filter angle shown here is the same as the one shown when you press **Pos**. If you have already set this value, there is no need to change it.

2. Set the speed at which the λ plates rotate:

- Set Speed to **Fast** and the averaging time of your power meter to longer than 1s to get measure the response to depolarized signal.

If it is not already selected:

- a. Move the Modify knob.
- b. Select **Fast** using the Modify knob, **⏴**, or **↓**.
- c. Press **Enter**, or **Select**.

- Set Speed to **Slow** and the averaging time of your power meter as short as possible, and use logging to measure polarization dependence.

If it is not already selected:

- a. Move the Modify knob.
- b. Select **Slow** using the Modify knob, **⏵**, or **↑**.
- c. Press **Enter**, or **Select**.

3. When everything is setup, press **Exec** to start the scan.

During the scan, values for the angle of $\lambda/4$ and $\lambda/2$ are shown on the display. These values are samples. The λ plates rotate continuously.

Example: Measuring the Response to a “Depolarized” Signal

To measure the response to a “depolarized” signal for a device under test (DUT), the steps are

- i. Set the polarizing filter.
- ii. Set the scanning speed to **Fast**.
- iii. Set the averaging time of the power meter.
- iv. Start the scan, and measure the value.

For this example, you will need, apart from the polarization controller, a laser source, and a power meter (in the description below, an HP 8153A Multimeter

3-2 Scanning the Poincare Sphere

with a laser module and a sensor module are used). A roll of fiber will act as a suitable DUT.

1. With both instruments switched off, connect the laser source to the polarization controller.
2. Connect the polarization controller to the power meter.

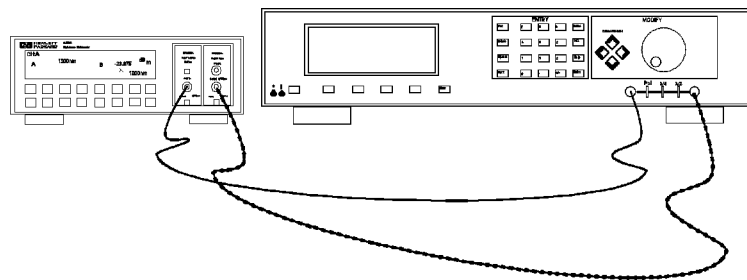

Setup for setting the position of the polarizing filter.

3. Switch on both instruments, and enable the laser source.

Note



Under normal circumstances you should leave the instruments to warmup. (The multimeter needs around 20 minutes to warmup.) Warming up is necessary for accuracy of the sensor, and the output power of the source.

4. Set the channel with the sensor module to the wavelength of the source, and select the default averaging speed (200ms) [Press **Param** to select T, hold **Param** to reset T].

Set the Polarizing Filter

5. Press **Home** on the polarization controller.
6. Press **Pos**.
7. Set the angle of the polarizing filter for maximum throughput.
 - a. Type in 10 and press **Enter**.
 - b. Press **⇒** twice to select the tens digit.
 - c. Using the Modify knob, increase the angle slowly until the power read on the multimeter increases and then starts to decrease.



3

- d. Press \Rightarrow once to select the units digit.
 - e. Using the Modify knob, decrease the angle slowly until the power read on the multimeter starts to decrease.
 - f. Press \Rightarrow twice to select the hundredths digit.
 - g. Using the Modify knob, increase the angle slowly until the power on the multimeter starts to decrease. Return to the angle that gave the maximum power.
8. Connect the DUT into the setup, disturbing the setup as little as possible.

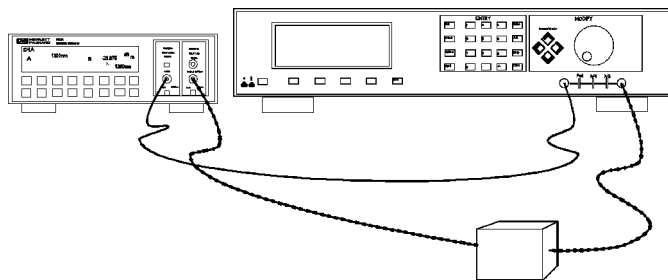

Setup with the DUT

Setting Up the Instruments

9. Run the sphere application with a fast scan.
 - a. Press **Sphere**.
 - b. Make sure that **Speed** is set to **Fast**.
If it is not, then
 - i. Move the Modify knob to start the parameter selection.
 - ii. Select **Fast** using the Modify knob, \downarrow , or \uparrow .
 - iii. Press **Select**.
10. Set the averaging time on the power meter to 1s [Press **Param** to select τ , press \uparrow to increase τ to 1s].

Running the Scan

11. Press **Exec** on the polarization controller.

3-4 Scanning the Poincare Sphere

There is a slight delay while the application is initialized, and then the values of $\lambda/4$ and $\lambda/2$ on the display begin to change.

12. When the application is running, read the value for the response of the DUT to a depolarised signal from the display for the power sensor.

Example: Measuring a Polarization Dependent Loss

3

To measure the sensitivity to polarization, apply a quasi-random polarization to the (DUT), the steps are

- i. Set the polarizing filter.
- ii. Set the scanning speed to Slow.
- iii. Set the power meter to record.
- iv. Start the scan, and record the readings for different polarization states.
- v. Analyze the results.

For this example, you will need, apart from the polarization controller, a laser source, and a power meter (in the description below, an HP 8153A Multimeter with a laser module and a sensor module are used). A roll of fiber will act as a suitable DUT.

1. With both instruments switched off, connect the laser source to the polarization controller.
2. Connect the polarization controller to the power meter.

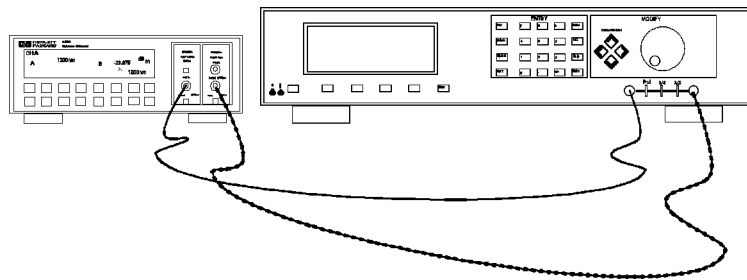

Setup for setting the position of the polarizing filter.

3. Switch on both instruments, and enable the laser source.

Note

Under normal circumstances you should leave the instruments to warmup. (The multimeter needs around 20 minutes to warmup.) Warming up is necessary for accuracy of the sensor, and the output power of the source.

 3

4. Set the channel with the sensor module to the wavelength of the source, and select the default averaging speed (200ms) [Press **Param** to select T, hold **Param** to reset T].

Set the Polarizing Filter

5. Press **Home** on the polarization controller.
6. Press **Pos**.
7. Set the angle of the polarizing filter for maximum throughput.
 - a. Type in 10 and press **Enter**.
 - b. Press **⇒** twice to select the tens digit.
 - c. Using the Modify knob, increase the angle slowly until the power read on the multimeter increases and then starts to decrease.
 - d. Press **⇒** once to select the units digit.
 - e. Using the Modify knob, decrease the angle slowly until the power read on the multimeter starts to decrease.
 - f. Press **⇒** twice to select the hundredths digit.
 - g. Using the Modify knob, increase the angle slowly until the power on the multimeter starts to decrease. Return to the angle that gave the maximum power.
8. Connect the DUT into the setup, disturbing the setup as little as possible.

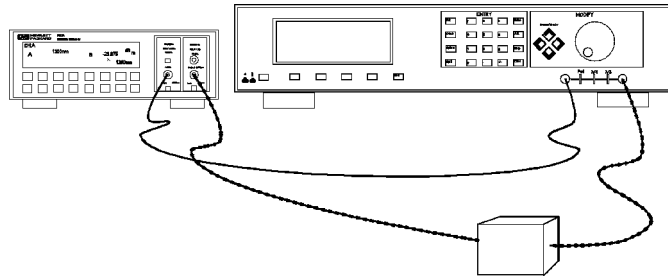

Setup with the DUT

Setting Up the Instruments

9. Run the sphere application with a slow scan.
 - a. Press **Sphere**.
 - b. Make sure that Speed is set to Slow. If it is not, then
 - i. Move the Modify knob to start the parameter selection.
 - ii. Select Slow using the Modify knob, **↑**, or **↓**.
 - iii. Press **Select**.
10. Set the averaging time on the power meter to 20ms [Press **Param** to select T, and **↓** to set it to 20ms].
11. Set up a Stability measurement over 20 seconds [Press **Menu**, and **Record** to select STABILITY. Press **Edit** to select T_TOTAL, and set it to 00:00:20, set AUTODUMP to OFF]

Running the Scan

12. Press **Exec** on the polarization controller.

There is a slight delay while the application is initialized, and then the values of $\lambda/4$ and $\lambda/2$ on the display begin to change.

13. When the scan is running, start the recording [Press **Exec**].

Analyzing the Results

14. When the recording is finished look at the results and find the difference between the highest and lowest [Press **More** to get SHOW, press **Edit**, and then **Next** twice to get DIFF].

This is the Polarization Dependent Loss for the DUT.

3

3-8 Scanning the Poincare Sphere

Other Front Panel Functions

This chapter covers setting the HP-IB address for the polarization controller, and storing and recalling instrument settings.

4

Setting the HP-IB Address

You can see or edit the HP-IB address of the instrument by pressing **(Syst)**.

The default HP-IB address is 24.

Storing or Recalling Instrument Settings

Press **(Syst)** and then **ST0/RCL** to see the actual, current setting of the instrument, the default setting for the instrument, and the 9 stored settings for the instrument.

View the various settings by using **Previous** and **Next**.

Storing a Setting

To store the actual instrument setting,

1. Find one of the nine numbered settings, which you can overwrite using **Previous** and **Next**.
2. Press **Store**.

Recalling a Setting

To recall a setting and make it the actual instrument setting,

1. Find the setting you want to restore, using **Previous** and **Next**.
2. Press **Recall**.

Resetting the Instrument

Resetting the instrument returns all the parameters to their default values (the polarization filter and both wavelength plates are reset to 0.00° and the speed for the sphere application is set to **Fast**).

To reset the instrument, you can either

1. Find the actual setting, using **Previous** and **Next**.
2. Press **Default**.

or

1. Find the default setting, using **Previous** and **Next**.
2. Press **Recall**.

4.2 Other Front Panel Functions

Programming the Polarization Controller

This chapter gives general information on how to control the polarization controller remotely. Descriptions for the actual commands for the polarization controller are given in the following chapters. The information in these chapters is specific to the polarization controller.

HP-IB Interface

The interface used by the polarization controller is the HP-IB (Hewlett-Packard Interface Bus).

This is the interface used for communication between a controller and an external device, such as the polarization controller. The HP-IB conforms to IEEE standard 488-1978, ANSI standard MC 1.1 and IEC recommendation 625-1.

The information in these chapters assumes that you are already familiar with programming over the HP-IB. If you are not familiar with the HP-IB, then refer to the following books:

- Hewlett-Packard Company. *Tutorial Description of Hewlett-Packard Interface Bus*, 1987.
- The International Institute of Electrical and Electronics Engineers. *IEEE Standard 488.1-1987, IEEE Standard Digital Interface for Programmable Instrumentation*. New York, NY, 1987
- The International Institute of Electrical and Electronics Engineers. *IEEE Standard 488.2-1987, IEEE Standard Codes, Formats, Protocols and Common Commands For Use with ANSI/IEEE Std 488.1-1987*. New York, NY, 1987

To obtain a copy of either of these last two documents, write to:
The Institute of Electrical and Electronics Engineers, Inc.
345 East 47th Street
New York, NY 10017
USA.

In addition, the commands not from the IEEE-488.2 standard, are defined according to the Standard Commands for Programmable Instruments (SCPI). For an introduction to SCPI, and SCPI programming techniques, refer to the following documents:

- Hewlett-Packard Press (Addison-Wesley Publishing Company, Inc). *A Beginners Guide to SCPI*. Barry Eppler. 1991.
- The SCPI Consortium. *Standard Commands for Programmable Instruments*. Published periodically by various publishers. To obtain a copy of this manual, contact your Hewlett-Packard representative.

The polarization controller interfaces to the HP-IB as defined by the IEEE Standards 488.1 and 488.2. The table shows the interface functional subset that the polarization controller implements.

5

Table 5-1. HP-IB Capabilities

Mnemonic	Function
SH1	Complete source handshake capability
AH1	Complete acceptor handshake capability
T6	Basic talker; serial poll; unaddressed to talk if addressed to listen
L4	Basic listener; unaddressed to listen if addressed to talk; no listen only
SR1	Complete service request capability
RL1	Complete remote/local capability
PP0	No parallel poll capability
DC1	Device clear capability
DT0	No device trigger capability
C0	No controller capability

5-2 Remote Operation

Setting the HP-IB Address

You can only set the HP-IB address from the front panel. See “Setting the HP-IB Address” in Chapter 4.

The default HP-IB address is 24.

Returning the Instrument to Local Control

If the instrument has been operated in remote the only key you can use is **Local**. The **Local** key returns the instrument to local control. **Local** does not operate if local lockout has been enabled.

How the Polarization Controller Receives and Transmits Messages

The polarization controller exchanges messages using an input and an output queue. Error messages are kept in a separate error queue.

How the Input Queue Works

The input queue is a FIFO queue (first-in first-out). Incoming bytes are stored in the input queue as follows:

1. Receiving a byte:
 - a. Clears the output queue.
 - b. Clears Bit 7 (MSB).
2. No modification is made inside strings or binary blocks. Outside strings and binary blocks, the following modifications are made:
 - a. Lower-case characters are converted to upper-case.
 - b. The characters 00_{16} to 09_{16} and $0B_{16}$ to $1F_{16}$ are converted to spaces (20_{16}).
 - c. Two or more blanks are truncated to one.

3. An EOI (End Or Identify) sent with any character is put into the input queue as the character followed by a line feed (LF, 0A₁₆). If EOI is sent with a LF, only one LF is put into the input queue.
4. The parser starts if the LF character is received or if the input queue is full.

Clearing the Input Queue

Switching the power off, or sending a Device Interface Clear signal, causes commands that are in the input queue, but have not been executed to be lost.

The Output Queue

The output queue contains responses to query messages. The polarization controller transmits any data from the output queue when a controller addresses the instrument as a talker.

Each response message ends with a LF (0A₁₆), with EOI=TRUE. If no query is received, or if the query has an error, the output queue remains empty.

The Message Available bit (MAV, bit 4) is set in the Status Byte register whenever there is data in the output queue.

The Error Queue

The error queue is a FIFO queue (first-in first-out). That is, the first error read is the oldest error to have occurred.

If too many errors are put into the queue, the message '-350 <Queue Overflow>' is placed as the last message in the queue.

Some Notes about Programming and Syntax Diagram Conventions

A program message is a message containing commands or queries that you send to the polarization controller. The following are a few points about program messages:

- You can use either upper-case or lower-case characters.
- You can send several commands in a single message. Each command must be separated from the next one by a semicolon (;).

5-4 Remote Operation

- You end a program message with a line feed (LF) character, or any character sent with End-Or-Identify (EOI).

Short Form and Long Form

The instrument accepts messages in short or long forms. For example, the message `:DISPLAY:ENABLE ON` is in long form, the short form of this message is `:DISP:ENAB ON`.

In this manual the messages are written in a combination of upper and lower case. Upper case characters are used for the short form of the message. For example, the above command would be written `:DISPlay:ENABle`.

The first colon can be left out for the first command or query in your message. That is, the example given above could also be sent as `DISP:ENAB ON`.

Command and Query Syntax

All characters not between angled brackets must be sent exactly as shown.

The characters between angled brackets (`< ... >`) show the kind of data that you send, or that you get in a response. You do not type the angled brackets in the actual message. Descriptions of these items follow the syntax description. The most common of these are:

- `string` is ascii data. A string is contained between a " at the start and the end, or a ' at the start and the end.
- `value` is numeric data in integer (12), decimal (34.5) or exponential format (67.8E-9).
- `wsp` is a white space.

Other kinds of data are described as required.

The characters between square brackets (`[...]`) show optional information that you can include with the message.

The bar (`|`) shows an either-or choice of data, for example, `a|b` means either *a* or *b*, but not both simultaneously.

Extra spaces are ignored; they can be inserted to improve readability.



6

Remote Commands

This chapter gives a list of the remote commands, for use with the HP-IB.

In the remote command descriptions the parts given in upper-case characters must be given. The parts in lower-case characters can also be given, but they are optional.

6



Command Summary

Table 6-1. Common Command Summary

Command	Parameter/Response	Min	Max	Function
*CLS				Clear Status Command
*ESE	<value>	0	255	Standard Event Status Enable Command
*ESE?	<value>	0	255	Standard Event Status Enable Query
*ESR?	<value>	0	255	Standard Event Status Register Query
*IDN?	<string>			Identification Query
*OPC				Operation Complete Command
*OPC?	<value>			Operation Complete Query
*RCL	<location>	0	9	Recall Instrument Setting
*RST				Reset Command
*SAV	<location>	1	9	Save Instrument Setting
*SRE	<value>	0	255	Service Request Enable Command
*SRE?	<value>	0	255	Service Request Enable Query
*STB?	<value>	0	255	Read Status Byte Query
*TST?	<value>	0	65535	Self Test Query
*WAI				Wait Command

Table 6-2. Command List

Command	Parameter	Unit	MINimum	MAXimum	DEFault
:ABORt					
:DISPly					
:ENABle	OFF 0 ON 1				
:ENABle?	0 1				
:INITiate					
[:IMMediate]					
[:INPut]					
:CIRClE					
:EPSilonb	<value>	†	-720.00	720.00	0.00
:EPSilonb?	<value>	†			
:THETap	<value>	†	-2160.00	2160.00	0.00
:THETap?	<value>	†			
:POSition					
:HALF	<value>	†	-360.00	360.00	0.00
:HALF?	<value>	†			
:POLarizer	<value>	†	-360.00	360.00	0.00
:POLarizer?	<value>	†			
:QUARter	<value>	†	-360.00	360.00	0.00
:QUARter?	<value>	†			
:PSPHere					
:RATE	0 1		0	1	1
:RATE?	0 1				
:STATus					
:OPERation					
:CONDition?	<value>				
:ENABle	<value>		0	65535	0
:ENABle?	<value>				
[:EVENT]?	<value>				
:NTRansition	<value>		0	65535	0
:NTRansition?	<value>				
:PTRansition	<value>		0	65535	0
:PTRansition?	<value>				
:PRESet					

6

Table 6-2. Command List (continued)

Command	Parameter	Unit	MINimum	MAXimum	DEFault
:STATus					
:QUEStionable					
:CONDition?	<value>				
:ENABle	<value>		0	65535	0
:ENABle?	<value>				
[:EVENT]?	<value>				
:NTRansition	<value>		0	65535	0
:NTRansition?	<value>				
:PTRansition	<value>		0	65535	0
:PTRansition?	<value>				
:SYSTem					
:ERRor?	<value>				
:VERSiOn?					[always returns 1994.0]

† No unit is specified, but all values are in degrees.

The Common Commands

The IEEE 488.2 standard has a list of reserved commands, called common commands. These are the commands that start with an asterisk. Some of these commands must be implemented by any instrument using the standard, others are optional. This section describes the implemented commands.

Common Status Information

There are four registers for the common status information. Two of these are status-registers and two are enable-registers. These registers conform to the *IEEE Standard 488.2-1987*. You can find further descriptions of these registers under “*ESE”, “*ESR?”, “*SRE”, and “*STB?”.

The following figure shows how the registers are organized.

Status Register

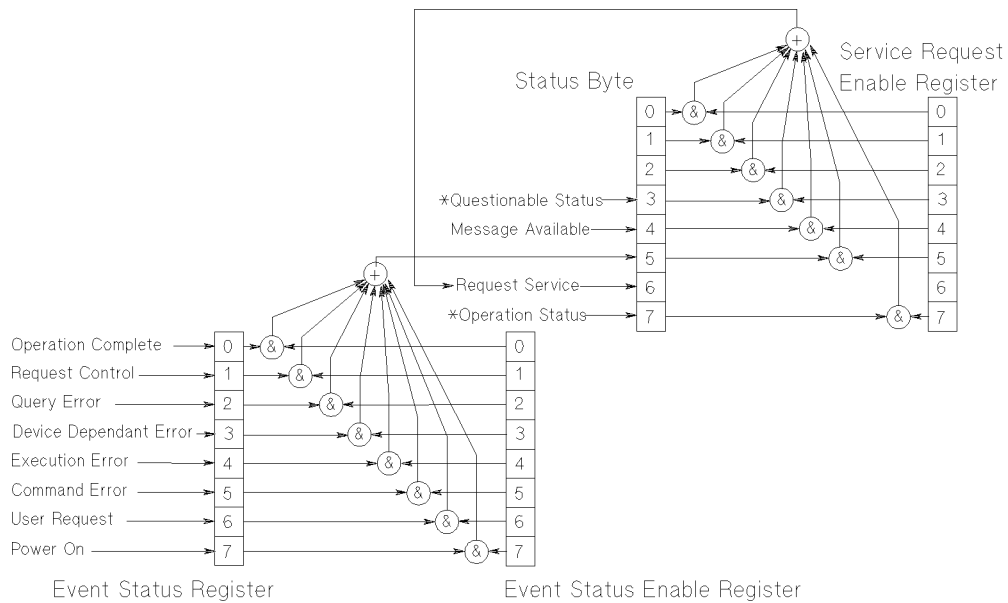

6

Figure 6-1. Common Status Registers

*The questionable and operation status trees are described in “STATUS Commands”.

Note

Unused bits in any of the registers return 0 when you read them.



SRQ, The Service Request

A service request (SRQ) occurs when a bit in the Status Byte register goes from 0 → 1 AND the corresponding bit in the Service Request Enable Mask is set.

The Request Service (RQS) bit is set to 1 at the same time that the SRQ is caused. This bit can only be reset by reading it by a serial poll. The RQS bit is

6-6 Remote Commands

not affected by the condition that caused the SRQ. The serial poll command transfers the value of the Status Byte register to a variable.

***CLS**

Syntax *CLS

Definition The *CLS command clears the following:

- Standard event status register (ESR)
- Status byte register (STB)
- The Error Queue

After the *CLS command the instrument is left waiting for the next command. The instrument setting is unaltered by the command, though *0PC/*0PC? actions are canceled.

If the *CLS command occurs directly after a program message terminator, the output queue and MAV, bit 4, in the status byte register are cleared, and if condition bits 2-0 of the status byte register are zero, MSS, bit 6 of the status byte register is also zero.

Example OUTPUT 724; "*CLS"

***ESE**

Syntax *ESE <wsp><value>
 0 ≤ value ≤ 255

Definition The *ESE command sets bits in the standard event status enable register (ESE) that enable the corresponding bits in the standard event status register (ESR).

The register is cleared:

- At power-on
- By sending a value of zero

The register is not changed by the *RST and *CLS commands.

The Event Status Enable Register

BIT	MNEMONIC	BIT VALUE
7	Power On	128
6	User Request	64
5	Command Error	32
4	Execution Error	16
3	Device dependent Error	8
2	Query Error	4
1	Request Control	2
0	Operation Complete	1

*ESE?

The standard event status enable query returns the contents of the standard event status enable register.

Example OUTPUT 724; "*ESE 21"

```
OUTPUT 724; "*ESE?"  
ENTER 724; A$
```

6

*ESR?

Syntax *ESR?

Definition The standard event status register query returns the contents of the standard event status register. The register is cleared after being read.

$0 \leq \text{contents} \leq 255$

The Standard Event Status Register		
BITS	MNEMONICS	BIT VALUE
7	Power On	128
6	User Request	64
4	Execution Error	16
3	Device Dependent Error	8
2	Query Error	4
1	Request Control	2
0	Operation Control	1

Example OUTPUT 724;"*ESR?"
 ENTER 724; A\$

***IDN?**

Syntax *IDN?

Definition The identification query commands the instrument to identify itself over the interface.

Response: HEWLETT-PACKARD , HP8169A, mmmmmmmmmmm , n .nn

 HEWLETT-PACKARD: manufacturer

 HP8169A: instrument model number

 mmmmmmmmmmm: serial number

 n .nn: firmware revision level

Example DIM A\$ [100]
 OUTPUT 724;"*IDN?"
 ENTER 724; A\$

*OPC

Syntax *OPC

Definition The instrument parses and executes all program message units in the input queue and sets the operation complete bit in the standard event status register (ESR). This command can be used to avoid filling the input queue before the previous commands have finished executing.

Example OUTPUT 724;"*CLS;*ESE 1;*SRE 32"
 OUTPUT 724;"*OPC"

*OPC?

This query causes all the program messages in the input queue to be parsed and executed. Once it has completed it places an ASCII '1' in the output queue. There is a short delay between interpreting the command and putting the '1' in the queue.

Example OUTPUT 724;"*CLS;*ESE 1;*SRE 32"
 OUTPUT 724;"*OPC?"
 ENTER 724;A\$

6

*RCL

Syntax *RCL <wsp> <location>

$0 \leq \text{location} \leq 9$

Definition An instrument setting from the internal RAM is made the actual instrument setting (this does not include HP-IB address or parser).

You recall user settings from locations 1-9. See "*SAV". Location 0 contains the default setting, which is the same as that obtained by *RST.

Example OUTPUT 724;"*RCL 3"

*RST

Syntax *RST

Definition The reset setting (default setting) stored in ROM is made the actual setting.

Instrument state: the instrument is placed in the idle state awaiting a command.

The following are not changed:

- HP-IB (interface) state
- Instrument interface address
- Output queue
- Service request enable register (SRE)
- Standard event status enable register (ESE)

The commands and parameters of the reset state are listed in the following table.

Table 6-3. Reset State (Default Setting)

Parameter	Reset Value
Pol	0.00°
$\lambda/4$	0.00°
$\lambda/2$	0.00°
Speed	Fast

6

Example OUTPUT 724; "*RST"

*SAV

Syntax *SAV <wsp> <location>

$1 \leq \text{location} \leq 9$

Definition The instrument setting is stored in RAM. You can store settings in locations 1-9. The scope of the saved setting is identical with the scope of the standard setting described in "*RST".

Example OUTPUT 724; "*SAV 3"

*SRE

Syntax *SRE <wsp> <value>
 $0 \leq \text{value} \leq 255$

Definition The service request enable command sets bits in the service request enable register that enable the corresponding status byte register bits.

The register is cleared:

- At power-on
- By sending a value of zero.

The register is not changed by the *RST and *CLS commands.

The Service Request Enable Register

BITS	MNEMONICS	BIT VALUE
7	Operation Status	128
6	Request Status	64
5	Event Status Byte	32
4	Message Available	16
3	Questionable Status	8
2	Not used	0
1	Not used	0
0	Not used	0

Note Bit 6 cannot be masked.



*SRE?

The service request enable query returns the contents of the service request enable register.

Example OUTPUT 724;"*SRE 48"

```
OUTPUT 724;"*SRE?"
ENTER 724; A$
```

***STB?**

Syntax *STB?

Definition The read status byte query returns the contents of the status byte register.

$0 \leq \text{contents} \leq 255$

The Status Byte Register

BITS	MNEMONICS	BIT VALUE
7	Operation Status	128
6	Request Service	64
5	Event Status Byte	32
4	Message Available	16
3	Questionable Status	8
2	Not used	0
1	Not used	0
0	Not used	0

6

Example OUTPUT 724;"*STB?"
ENTER 724; A\$

***TST?**

Syntax *TST?

Definition The self-test query commands the instrument to perform a self-test and place the results of the test in the output queue.

Returned value: $0 \leq \text{value} \leq 65535$. This value is the sum of the results for the individual tests

The Self Test Results		
BITS	MNEMONICS	BIT VALUE
14	Motor 3	16384
13	Motor 2	8192
12	Motor 1	4096
10	Counter 3	1024
9	Counter 2	512
8	Counter 1	256
5	DSP Timeout	32
4	DSP Communications	16
3	Calibration Data	8
1	Battery RAM	2
0	Calibration Data Checksum	1

So 16 would mean that the DSP (Digital Signal Processor) Communications had failed, 18 would mean that the DSP Communications had failed, and so had the Battery RAM. A value of zero shows no errors.

No further commands are allowed while the test is running.

The instrument is returned to the setting that was active at the time the self-test query was processed.

The self-test does not require operator interaction beyond sending the *TST? query.

Example OUTPUT 724; "*TST?"
 ENTER 724; A\$

***WAI**

Syntax *WAI

Definition The wait-to-continue command prevents the instrument from executing any further commands, all pending operations are completed.

Example OUTPUT 724; "*WAI"

6-14 Remote Commands

Switching On and Off the Instrument Display

These are the commands for enabling or disabling the display on the instrument.

:DISPlay:ENABle

Syntax :DISPlay:ENABle <wsp> OFF|ON|0|1

Description This command enables or disables the front panel display.

Set the state to OFF or 0 to switch the display off, set the state to ON or 1 to switch the display on. The default is for the display to be on.

:DISPlay:ENABle?

Syntax :DISPlay:ENABle?

Description The query returns the current state of the display.

A returned value of 0 shows that the display is off. A returned value of 1 shows that the display is on.

Example OUTPUT 724;":DISP:ENAB ON"

 OUTPUT 724;":DISP:ENAB?"
 ENTER 724;A\$

6

Positioning the Polarizing Filter

These are the commands that deal with the position of the polarizing filter.

[:INPut]:POSition:POLarizer

Syntax [:INPut]:POSition:POLarizer <wsp>
 <value>|MINimum|MAXimum|DEFault
 where value is a floating point number between -360.00 and
 360.00.

Description This command sets the position of the polarizing filter. The
 parameter may be either

- a number, in mechanical degrees (do not give a unit; the number will be rounded to the nearest 0.05°),
- MINimum (-360.00°),
- MAXimum (360.00°), or
- DEFault (0.00°).

[:INPut]:POSition:POLarizer?

Syntax [:INPut]:POSition:POLarizer?

Description This query gets the position of the polarizing filter in mechanical
 degrees (without a unit).

Example OUTPUT 724;"POS:POL 127"

 OUTPUT 724;"POS:POL?"
 ENTER 724;A\$

6

Setting the State of Polarization

These are the commands that deal with positioning the $\lambda/4$ and $\lambda/2$ retarder plates, and setting the state of polarization by specifying the coordinates on the Poincare sphere.

[:INPut]:CIRClE:EPSilonb

Syntax `[:INPut]:CIRClE:EPSilonb <wsp>
<value>|MINimum|MAXimum|DEFault`
where value is a floating point number between -720.00 and 720.00.

Description This command sets the $2\varepsilon_B$ position on of the Poincare sphere. The parameter may be either

- a number, in optical degrees (do not give a unit; the number will be rounded to the nearest 0.05°),
- MINimum (-720.00°),
- MAXimum (720.00°), or
- DEFault (0.00°).

Note The value you specify with this command is for $2\varepsilon_B$.



6

[:INPut]:CIRClE:EPSilonb?

Syntax `[:INPut]:CIRClE:EPSilonb?`

Description This query gets the $2\varepsilon_B$ position on the Poincare sphere in optical degrees (without a unit).

Note The value returned by this query is for $2\varepsilon_B$.



[:INPut]:CIRClE:THETap

Syntax [:INPut]:CIRClE:THETap <wsp>
 <value>|MINimum|MAXimum|DEFault
 where value is a floating point number between -2160.00 and
 2160.00.

Description This command sets the position of the $2\theta_P$ position on the
Poincare sphere. The parameter may be either

- a number, in optical degrees (do not give a unit; the number
 will be rounded to the nearest 0.05°),
- MINimum (-2160.00°),
- MAXimum (2160.00°), or
- DEFault (0.00°).

Note The value you specify with this command is for $2\theta_P$.



[:INPut]:CIRClE:THETap?

Syntax [:INPut]:CIRClE:THETap?

Description This query gets the position of the $2\theta_P$ position on the Poincare
sphere in optical degrees (without a unit).

Note The value returned by this query is for $2\theta_P$.



Example OUTPUT 724;":CIRC:EPS 128"
 OUTPUT 724;":CIRC:THET 270"

 OUTPUT 724;":CIRC:EPS?"
 ENTER 724;E\$
 OUTPUT 724;":CIRC:THET?"
 ENTER 724;T\$

[:INPut]:POSition:HALF

Syntax [:INPut]:POSition:HALF <wsp>
<value>|MINimum|MAXimum|DEFault
where value is a floating point number between -360.00 and 360.00.

Description This command sets the position of the $\lambda/2$ retarder plate. The parameter may be either

- a number, in mechanical degrees (do not give a unit; the number will be rounded to the nearest 0.05°),
- MINimum (-360.00°),
- MAXimum (360.00°), or
- DEFault (0.00°).

[:INPut]:POSition:HALF?

Syntax [:INPut]:POSition:HALF?

Description This query gets the position of the $\lambda/2$ retarder plate in mechanical degrees (without a unit).

[:INPut]:POSition:QUARter

Syntax [:INPut]:POSition:QUARter <wsp>
<value>|MINimum|MAXimum|DEFault
where value is a floating point number between -360.00 and 360.00.

Description This command sets the position of the $\lambda/4$ retarder plate. The parameter may be either

- a number, in mechanical degrees (do not give a unit; the number will be rounded to the nearest 0.05°),
- MINimum (-360.00°),
- MAXimum (360.00°), or
- DEFault (0.00°).

[:INPut]:POSiTion:QUARter?

Syntax [:INPut]:POSiTion:QUARter?

Description This query gets the position of the $\lambda/4$ retarder plate in mechanical degrees (without a unit).

Example OUTPUT 724;":POS:QUAR 64"
 OUTPUT 724;":POS:HALF 99.5"

 OUTPUT 724;":POS:QUAR?"
 ENTER 724;Q\$
 OUTPUT 724;":POS:HALF?"
 ENTER 724;H\$

Scanning the Sphere

These are the commands for varying the state of polarization automatically over time.

[:INPut]:PSPHere:RATE

Syntax [:INPut]:PSPHere:RATE <wsp> 0|1

Description This command sets the speed at which the the state of polarization is changed.

- 0 set the speed to slow (for polarization dependent measurements), or
- 1 sets the speed to fast (for quasi-depolarized signals).

[:INPut]:PSPHere:RATE?

Syntax [:INPut]:PSPHere:RATE?

Description This query gets the the speed at which the the state of polarization is set to change.

- 0 if the speed is set to slow.
- 1 if the speed is set to fast, or

:INITiate[:IMMediate]

Syntax :INITiate[:IMMediate]

Description This command starts the application.

:ABORt

Syntax :ABORt

Description This command aborts an application that is running.

Example OUTPUT 724;":PSPH:RATE 1"
 OUTPUT 724;":INIT"
 :
 OUTPUT 724;":PSPH:RATE?"
 ENTER 724;R\$
 :
 :

OUTPUT 724;":ABOR"

6

6-22 Remote Commands

STATUS Commands

There are two 'nodes' in the status circuitry.

The OPERATION node shows things that can happen during normal operation.

The QUESTIONABLE node shows error conditions.

Each node of the status circuitry has five registers:

- A condition register (CONDITION), which contains the current status. This register is updated continuously. It is not changed by having its contents read.
- The event register (EVENT), which contains the output from the transition registers. The contents of this register are cleared when it is read.
- A positive transition register (PTRANSITION), which, when enabled, puts a 1 into the event register, when the corresponding bit in the condition register goes from 0 to 1.

The power-on condition for this register is for all the bits to be enabled.

- A negative transition register (NTRANSITION), which, when enabled, puts a 1 into the event register, when the corresponding bit in the condition register goes from 1 to 0.

The power-on condition for this register is for all the bits to be disabled.

- The enable register (ENABLE), which enables changes in the event register to affect the Status Byte.

The status registers for the polarization controller are organized as shown:

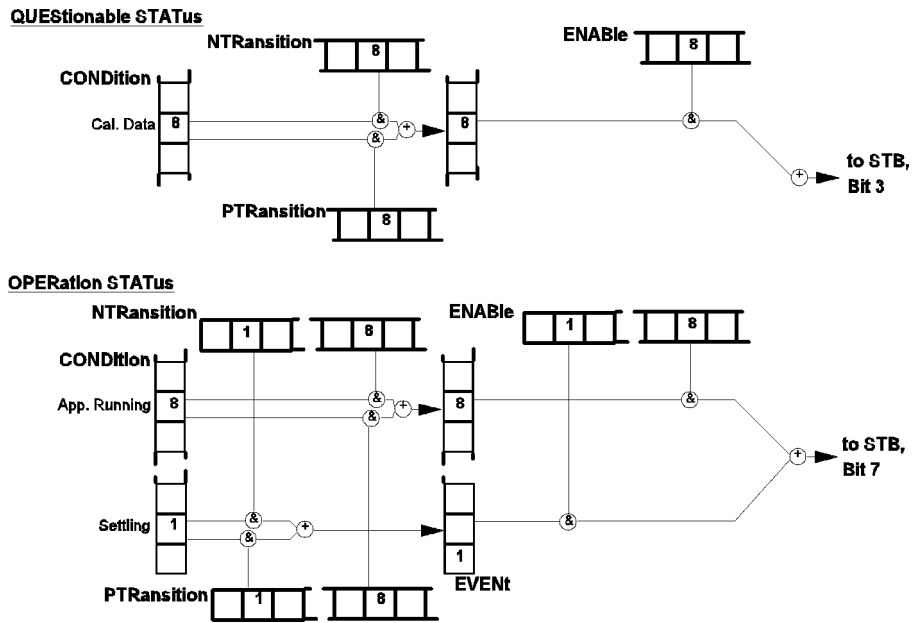

Figure 6-2. The Status Registers

6

Setting Up the STATUS Registers

These are the commands for setting up the registers.

:STATus:PRESet

Syntax :STATus:PRESet

Description This command presets all the enable registers and transition filters for both the OPERAtion and QUEStionable nodes.

- All the bits in the ENABle registers are set to 0
- All the bits in the PTRansition registers are set to 1
- All the bits in the NTRansition registers are set to 0

Example OUTPUT 724;":STAT:PRESet"

Only two bits of the OPERation node are used:

- Bit 1 to show that the instrument is settling (that is that the polarizer and the $\lambda/4$ and $\lambda/2$ plates have not reached position.
- Bit 8 shows that an application is running.

:STATus:OPERation:NTRansition

Syntax :STATus:OPERation:NTRansition <wsp> <value>

Description This command sets the bits in the NTRansition register. Setting a bit in this register enables a negative transition (1→0) in the corresponding bit in the CONDition register to set the bit in the EVENT register.

:STATus:OPERation:NTRansition?

Syntax :STATus:OPERation:NTRansition?

Description This query returns the current contents of the OPERation:NTRansition register.

:STATus:OPERation:PTRansition

Syntax :STATus:OPERation:PTRansition <wsp> <value>

Description This command sets the bits in the PTRansition register. Setting a bit in this register enables a positive transition (0→1) in the corresponding bit in the CONDition register to set the bit in the EVENT register.

:STATus:OPERation:PTRansition?

Syntax :STATus:OPERation:PTRansition?

Description This query returns the current contents of the OPERation:PTRansition register.

:STATus:OPERation:ENABLE

Syntax :STATus:OPERation:ENABLE <wsp> <value>

Description This command sets the bits in the ENABLE register that enable the contents of the EVENT register to affect the Status Byte (STB). Setting a bit in this register to 1 enables the corresponding bit in the EVENT register to affect bit 7 of the Status Byte.

:STATus:OPERation:ENABle?.

Syntax :STATus:OPERation:ENABle?

Description This query returns the current contents of the OPERation:ENABle register.

Example

```
OUTPUT 724;":STAT:OPER:NTR 2"  
OUTPUT 724;":STAT:OPER:PTR 256"  
OUTPUT 724;":STAT:OPER:ENAB 258"  
  
OUTPUT 724;":STAT:OPER:NTR?"  
ENTER 724;N$  
OUTPUT 724;":STAT:OPER:PTR?"  
ENTER 724;P$  
OUTPUT 724;":STAT:OPER:ENAB?"  
ENTER 724;E$
```

Only one bit of the QUESTIONable node is used:

- Bit 8 shows that there is an error in the calibration data.

:STATus:QUEStionable:NTRansition

Syntax :STATus:QUEStionable:NTRansition <wsp> <value>

Description This command sets the bits in the NTRansition register. Setting a bit in this register enables a negative transition (1→0) in the corresponding bit in the CONDition register to set the bit in the EVENT register.

:STATus:QUEStionable:NTRansition?

Syntax :STATus:QUEStionable:NTRansition?

Description This query returns the current contents of the QUESTIONable:NTRansition register.

:STATus:QUEStionable:PTRansition

Syntax :STATus:QUEStionable:PTRansition <wsp> <value>

Description This command sets the bits in the PTRansition register. Setting a bit in this register enables a positive transition (0→1) in the corresponding bit in the CONDition register to set the bit in the EVENT register.

:STATus:QUEStionable:PTRansition?

Syntax :STATus:QUEStionable:PTRansition?

Description This query returns the current contents of the QUESTIONable:PTRansition register.

:STATus:QUEStionable:ENABle

Syntax :STATus:QUEStionable:ENABle <wsp> <value>

Description This command sets the bits in the ENABle register that enable the contents of the EVENT register to affect the Status Byte (STB). Setting a bit in this register to 1 enables the corresponding bit in the EVENT register to affect bit 3 of the Status Byte.

:STATus:QUEStionable:ENABle?.

Syntax :STATus:QUEStionable:ENABle?

Description This query returns the current contents of the QUEStionable:ENABle register.

Example

```
OUTPUT 724;":STAT:QUES:NTR 256"  
OUTPUT 724;":STAT:QUES:PTR 256"  
OUTPUT 724;":STAT:QUES:ENAB 256"  
  
OUTPUT 724;":STAT:QUES:NTR?"  
ENTER 724;N$' '  
OUTPUT 724;":STAT:QUES:PTR?"  
ENTER 724;P$' '  
OUTPUT 724;":STAT:QUES:ENAB?"  
ENTER 724;E$
```

Checking the Status

These commands are for checking the status of the instrument, as reported in the OPERational and QUEStionable STATus registers.

Note See also “The Common Commands” for the standard IEEE 488.2 status registers.



:STATus:OPERation:CONDition?

Syntax :STATus:OPERation:CONDition?

Description This query reads the contents of the OPERation:CONDition register. Only two bits of the condition register are used:

<u>BITS</u>	<u>MNEMONICS</u>	<u>BIT VALUE</u>
8	Settling	256
1	Application	2

Example OUTPUT 724;":STAT:OPER:COND?"
ENTER 724;A\$

:STATus:OPERation[:EVENT]?

Syntax :STATus:OPERation[:EVENT]?

Description This query reads the contents of the OPERation:EVENT register. Only two bits of the event register are used (whether these bits contain information depends on the transition register configuration):

<u>BITS</u>	<u>MNEMONICS</u>	<u>BIT VALUE</u>
8	Settling	256
1	Application	2

Example OUTPUT 724;":STAT:OPER?"
ENTER 724;A\$

:STATus:QUEStionable:CONDition?

Syntax :STATus:QUEStionable:CONDition?

Description This query reads the contents of the QUEStionable:CONDition register. Only one bit of the condition register is used:

<u>BITS</u>	<u>MNEMONICS</u>	<u>BIT VALUE</u>
8	Calibration Data	256

Example OUTPUT 724;":STAT:QUES:COND?"
ENTER 724;A\$

:STATus:QUEStionable[:EVENT]?

Syntax :STATus:QUEStionable[:EVENT]?

Description This query reads the contents of the QUEStionable:EVENT register. Only one bit of the event register is used (whether these bits contain information depends on the transition register configuration):

<u>BITS</u>	<u>MNEMONICS</u>	<u>BIT VALUE</u>
8	Calibration Data	256

Example OUTPUT 724;":STAT:QUES?"
ENTER 724;A\$

6

SYSTEM Commands

:SYSTEM:ERRor?

Syntax :SYSTEM:ERRor?

Description This query returns the next error from the error queue (see “The Error Queue” in Chapter 5). Each error has the error code and a short description of the error, separated by a comma, for example 0, “No error”. Error codes are numbers in the range -32768 and +32767. Negative error numbers are defined by the SCPI standard. Positive error numbers are device dependent. The errors are listed in Appendix F

Example OUTPUT 724; “:SYST:ERR?”
ENTER 724; A\$

:SYSTEM:VERSion?

Syntax :SYSTEM:VERSion?

Description This query returns the version of the SCPI command set being used in the format *yyyy.v*, where *yyyy* is the year, and *v* is the version. For this instrument, the value returned is always 1994.0

Example OUTPUT 724; “:SYST:VERS?”
ENTER 724; A\$



7

Programming Examples

This chapter gives some programming examples. The language used for the programming is BASIC 5.1 Language System used on HP 9000 Series 200/300 computers.

These programming examples do not cover the full command set for the instrument. They are intended only as an introduction to the method of programming the instrument. The programming examples use the HP-IB.

Example 1 - Checking Communication

Function

This program sends a query, and displays the reply.

Listing

```
10  !-----
20  !
30  ! HP 8169A Programming Example 1
40  !
50  ! A Simple Communications Check
60  !
70  !-----
80  !
90  ! Definitions and initialization
100 !
```

```
110 Pol=724
```

This statement sets the address of the polarization controller. The first 7 is to access the HP-IB card in the controller; the 24 is it's HP-IB address

```
120 DIM String$(50)
130 !
150 PRINT TABXY(5,10);"Programming Example 1, Simple Communications"
160 !
170 ! Send an IDN query and get the Identification
180 !
190 OUTPUT Pol;"*IDN?"
200 ENTER Pol;String$
210 PRINT TABXY(10,12);"Identification : ";String$
220 !
230 END
```

7

7-2 Programming Examples

Example 2 - Status Registers and Queues

```
300 PRINT TABXY(4,6);"          :"  
310 PRINT TABXY(4,7);" +-----+ "  
320 PRINT TABXY(4,8);" :          OR          : "  
330 PRINT TABXY(4,9);" +-----+ "  
340 PRINT TABXY(4,10);" ^ ^ ^ ^ ^ ^ ^ ^ "  
350 PRINT TABXY(4,11);" +---+---+---+---+---+---+---+---+---+ "  
360 PRINT TABXY(4,12);" : : : : : : : : : : : "  
370 PRINT TABXY(4,13);" +---+---+---+---+---+---+---+---+---+ "  
380 PRINT TABXY(4,14);" PON URQ CME EXE DDE QYE RQC OPC "  
390 PRINT TABXY(40,12);"Standard Event Status Register"  
400 PRINT TABXY(4,16);"Last Command : "  
410 PRINT TABXY(4,17);"Last Error   : "  
420 PRINT TABXY(4,18);"Output Queue : "  
430 !  
440 ! Start the program loop and enable the interrupt for the errors  
450 !  
460 Ende=0  
470 GOSUB Pmm_srq  
480 ENABLE INTR 7;2  
490 !  
500 ! The Central Loop  
510 !  
520 REPEAT  
530   INPUT "Command ? ",Inp$  
540   GOSUB Pmm_srq  
550   OUTPUT Pol;Inp$  
560   PRINT TABXY(21,16);"          "  
570   PRINT TABXY(21,16);Inp$          "  
580   WAIT 1.0  
590 UNTIL Ende=1  
600 GOTO 1380  
610 !  
620 !-----  
630 Pmm_srq: ! Interrupt Handling Subroutine to display the status, and the  
640 ! error and output queues  
650 !-----  
660 !  
670 ! Get the value for the Status Byte  
680 !  
690 Value=SPOLL(Pol)  
700 !  
710 ! Initialize and start the display of the registers  
720 !  
730 PRINT TABXY(21,17);"          "  
740 PRINT TABXY(21,18);"          "  
750 Ypos=3
```

7.4 Programming Examples

Example 2 - Status Registers and Queues

```
760 FOR Z=0 TO 1
770   Bit=128
780   Xpos=7
790   !
800   ! Do it for each bit
810   !
820   REPEAT
830     Quot=Value DIV Bit
840     !
850     ! If the bit is set then display 1
860     !
870     IF Quot>0 THEN
880       PRINT TABXY(Xpos,Ypos);"1"
890       Value=Value-Bit
900       !
910       ! If MAV is set, then get and display the output queue contents
920       !
930       IF Z=0 THEN
940         IF Bit=16 THEN
950           ENTER Pol;A$
960           PRINT TABXY(21,18);A$
970         END IF
980       END IF
990       !
1000      ! If the bit is not set, then display 0
1010      !
1020      ELSE
1030        PRINT TABXY(Xpos,Ypos);"0"
1040      END IF
1050      !
1060      ! Set up for the next iteration
1070      !
1080      Bit=Bit DIV 2
1090      Xpos=Xpos+4
1100    UNTIL Bit=0
1110    !
1120    ! Now that the status byte is displayed, get the Standard Events
1130    ! Status Register
1140    !
1150    OUTPUT Pol;"*ESR?"
1160    ENTER Pol;Value
1170    !
1180    ! Set up to display the ESR
1190    !
1200    Ypos=12
1210  NEXT Z
```

Example 2 - Status Registers and Queues

```
1220 !
1230 ! Read and display any messages in the error queue
1240 !
1250 REPEAT
1260     OUTPUT Pol;"SYSTEM:ERROR?"
1270     ENTER Pol;Value,A$
The SYSTEM:ERROR? query gets the number of the last error in the error queue.
1280     IF Value<>0 THEN PRINT TABXY(21,17);Value,A$
1290 UNTIL Value=0
1300 !
1310 ! Clear the Status structure and reenable the interrupt before returning
1320 !
1330 OUTPUT Pol;"*CLS"
1340 ENABLE INTR 7
1350 !
1360 RETURN
1370 !
1380 END
```

Example 3 - Finding the Optimum Transmission SoP

Example 3 - Finding the Optimum Transmission SoP

Function

This program performs the same sequence as the example session given in chapter 2. That is, to find the state of polarization for optimum transmission for a linear device under test (DUT).

Requirements

For this example, you will need, apart from the polarization controller, a laser source, and a power meter (in the description below, an HP 8153A Multimeter with a laser module and a sensor module are used). We will use the length of fiber connecting the instruments as our linear DUT.

Setting Up the Equipment

1. With both instruments switched off, connect the laser source to the polarization controller.
2. Connect the polarization controller to the power meter.

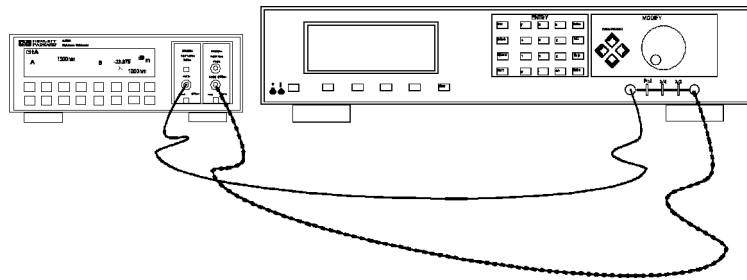

Setup for setting the position of the polarizing filter.

3. Switch on both instruments, and enable the laser source.
4. Set the channel with the sensor module to the wavelength of the source, and select the default averaging speed (200ms).



Example 3 - Finding the Optimum Transmission SoP

Note



Under normal circumstances you should leave the instruments to warmup. (The multimeter needs around 20 minutes to warmup.) Warming up is necessary for accuracy of the sensor, and the output power of the source.

Listing

```
10  !-----
20  !
30  ! Programming Example 3
40  !
50  ! Finding the Optimum Transmission Polarization
60  !
70  !-----
80  !
90  ! Definitions and Initializations
100 !
110 Pol=724
120 Mm=722
130 !
140 OUTPUT Mm;"*rst;*cls"
150 OUTPUT Pol;"*rst;*cls"
160 !
170 ! Setup the instruments, with the output of the source connected
180 ! to the input of the sensor and wait for the ENTER key to be
190 ! pressed before continuing
200 !
210 CLEAR SCREEN
220 True=1
230 False=0
240 !
250 ! Set the Wavelength and the averaging time for the sensor
260 !
270 OUTPUT Mm;"sour:pow:wave?"
280 ENTER Mm;Wl
290 OUTPUT Mm;"sens2:pow:wave ";Wl
300 OUTPUT Mm;"sens2:pow:atime 200ms"
310 !
320 ! Switch on the source
330 !
340 OUTPUT Mm;"sour:pow:state on"
350 !
360 ! Find the position of the polarizing filter, that allows the maximum
370 ! power through
380 !
390 Angle=0
```

7

7-8 Programming Examples

Example 3 - Finding the Optimum Transmission SoP

```
400 Inc=10
410 Maxward=False
420 OUTPUT Mm;"read2:power?"
430 ENTER Mm;Maxpow
440 REPEAT
450   Angle=Angle+Inc
460   OUTPUT Pol;"pos:pol ";Angle
470   OUTPUT Mm;"read2:power?"
480   ENTER Mm;Newpow
490   IF Newpow<Maxpow THEN
500     IF Maxward=True THEN
510       Inc=-Inc/2
520     ELSE
530       Inc=-Inc
540       Maxward=True
550     END IF
560   ELSE
570     Maxpow=Newpow
580     Maxward=True
590   END IF
600 UNTIL ABS(Inc)<.05
610 !
620 ! Now search for the worst-case polarization when changing thetap
630 !
640 Angle=0
650 Inc=10
660 Minward=False
670 Minpow=Maxpow
680 REPEAT
690   Angle=Angle+Inc
700   OUTPUT Pol;"circle:thetap ";Angle
710   OUTPUT Mm;"read2:power?"
720   ENTER Mm;Newpow
730   IF Newpow>Minpow THEN
740     IF Minward=True THEN
750       Inc=-Inc/2
760     ELSE
770       Inc=-Inc
780       Minward=True
790     END IF
800   ELSE
810     Minpow=Newpow
820     Minward=True
830   END IF
840 UNTIL ABS(Inc)<.05
850 !
860 ! Now search for the overall worst-case polarization by changing epsilon
870 !
880 Angle=0
```

7

Example 3 - Finding the Optimum Transmission SoP

```
890 Inc=10
900 Minward=False
910 REPEAT
920   Angle=Angle+Inc
930   OUTPUT Pol;"circle:epsilonb ";Angle
940   OUTPUT Mm;"read2:power?"
950   ENTER Mm;Newpow
960   IF Newpow>Minpow THEN
970     IF Minward=True THEN
980       Inc=-Inc/2
990     ELSE
1000      Inc=-Inc
1010      Minward=True
1020    END IF
1030  ELSE
1040    Minpow=Newpow
1050    Minward=True
1060  END IF
1070 UNTIL ABS(Inc)<.05
1080 !
1090 ! Now set the optimum by moving to the opposite side of the
1100 ! sphere
1110 !
1120 OUTPUT Pol;"circle:epsilonb ";Angle+180
1130 !
1140 ! And finish . . .
1150 !
1160 OUTPUT Mm;"sour:pow:state off"
1170 END
```

7

Example 4 - Finding the Polarization Dependence

Example 4 - Finding the Polarization Dependence

Function

This program does the same thing as the example session given in chapter 3. That is, to measure the sensitivity to polarization, by applying a quasi-random polarization to the (DUT).

Requirements

For this example, you will need, apart from the polarization controller, a laser source, and a power meter (in the description below, an HP 8153A Multimeter with a laser module and a sensor module are used). A roll of fiber will act as a suitable DUT.

Setting Up the Equipment

1. With both instruments switched off, connect the laser source to the polarization controller.
2. Connect the polarization controller to the power meter.

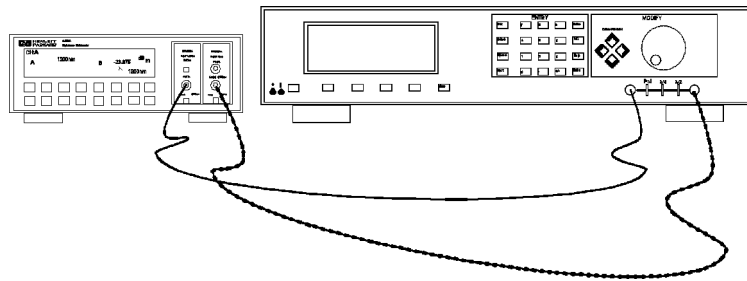

Setup for setting the position of the polarizing filter.

3. Switch on both instruments, and enable the laser source.

Note



Under normal circumstances you should leave the instruments to warmup. (The multimeter needs around 20 minutes to warmup.) Warming up is necessary for accuracy of the sensor, and the output power of the source.



Example 4 - Finding the Polarization Dependence

4. Set the channel with the sensor module to the wavelength of the source, and select the default averaging speed (200ms) [Press **Param** to select T, hold **Param** to reset T].

When prompted by the program, you should connect the DUT into the setup, disturbing the setup as little as possible.

Listing

```
10  !-----
10  !
20  !
30  ! Programming Example 4
40  !
50  ! Finding the Polarization Dependence
60  !
70  !-----
80  !
90  ! Definitions and Initializations
100 !
110 Pol=724
120 Mm=722
130 !
140 OUTPUT Mm;"*rst;*cls"
150 OUTPUT Pol;"*rst;*cls"
160 !
170 ! Setup the instruments, with the output of the source connected
180 ! to the input of the sensor and wait for the ENTER key to be
190 ! pressed before continuing
200 !
210 CLEAR SCREEN
220 True=1
230 False=0
240 !
250 ! Set the Wavelength and the averaging time for the sensor
260 !
270 OUTPUT Mm;"sour:pow:wave?"
280 ENTER Mm;Wl
290 OUTPUT Mm;"sens2:pow:wave ";Wl
300 OUTPUT Mm;"sens2:pow:atime 200ms"
310 !
320 ! Switch on the source
330 !
340 OUTPUT Mm;"sour:pow:state on"
350 !
360 ! Find the position of the polarizing filter, that allows the maximum
370 ! power through
380 !
390 Angle=0
```

7.12 Programming Examples

Example 4 - Finding the Polarization Dependence

```
400 Inc=10
410 Maxward=False
420 OUTPUT Mm;"read2:power?"
430 ENTER Mm;Maxpow
440 REPEAT
450     Angle=Angle+Inc
460     OUTPUT Pol;"pos:pol ";Angle
470     OUTPUT Mm;"read2:power?"
480     ENTER Mm;Newpow
490     IF Newpow<Maxpow THEN
500         IF Maxward=True THEN
510             Inc=-Inc/2
520         ELSE
530             Inc=-Inc
540             Maxward=True
550         END IF
560     ELSE
570         Maxpow=Newpow
580         Maxward=True
590     END IF
600 UNTIL ABS(Inc)<.05
610 !
620 ! Time to insert the DUT
630 !
640 PRINT TABXY(10,9);"Hit ENTER when you have inserted the DUT!"
650 INPUT Dummy
660 !
670 ! Set up the instruments for slow scanning of the sphere, and at fast
680 ! measurement time to sample the power
690 !
700 OUTPUT Pol;"psphere:rate 0"
710 OUTPUT Mm;"sens2:pow:atime 20ms"
720 OUTPUT Mm;"sens2:pow:unit dbm"
730 ! Set values that have to change for maximum and minimum
740 Minpow=100
750 Maxpow=-100
760 !
770 ! Start the scanning
780 !
790 OUTPUT Pol;"init"
800 !
810 ! Sample enough values to be sure of catching the maximum and minimum
820 !
830 FOR Reading=1 TO 500
840     OUTPUT Mm;"read2:pow?"
850     ENTER Mm;Power
860     IF Power<Minpow THEN Minpow=Power
870     IF Power>Maxpow THEN Maxpow=Power
890 NEXT Reading
```

Example 4 - Finding the Polarization Dependence

```
900 !  
910 ! Calculate (and display) the difference  
920 !  
930 PRINT TABXY(10,12);"Polarization Dependence",Maxpow-Minpow;"dB"  
940 !  
950 ! Tidy up and leave  
960 !  
970 OUTPUT Pol;"abort"  
980 OUTPUT Mm;"sour:pow:state off"  
990 END
```

7

A

Installation

This appendix provides installation instructions for the polarization controller. It also includes information about initial inspection and damage claims, preparation for use, packaging, storage, and shipment.

Safety Considerations

The polarization controller is a Class 1 instrument (that is, an instrument with an exposed metal chassis directly connected to earth via the power supply cable). The symbol used to show a protective earth terminal in the instrument is

Before operation, review the instrument and manual for safety markings and instructions. You must follow these to ensure safe operation and to maintain the instrument in safe condition.

Initial Inspection

Inspect the shipping container for damage. If there is damage to the container or cushioning, keep them until you have checked the contents of the shipment for completeness and verified the instrument both mechanically and electrically.

The Appendix D gives a procedure for checking the operation of the instrument. If the contents are incomplete, mechanical damage or defect is apparent, or if an instrument does not pass the operator's checks, notify the nearest Hewlett-Packard office.

A

Warning

To avoid hazardous electrical shock, do not perform electrical tests when there are signs of shipping damage to any portion of the outer enclosure (covers, panels, etc.).

AC Line Power Supply Requirements

The HP 8169A can operate from any single-phase AC power source that supplies between 100V and 240V $\pm 10\%$, at a frequency in the range from 50 to 60Hz. The maximum power consumption is 45VA with all options installed.

Line Power Cable

According to international safety standards, this instrument has a three-wire power cable. When connected to an appropriate AC power receptacle, this cable earths the instrument cabinet. The type of power cable shipped with each instrument depends on the country of destination. Refer to Figure A-1 for the part numbers of the power cables available.

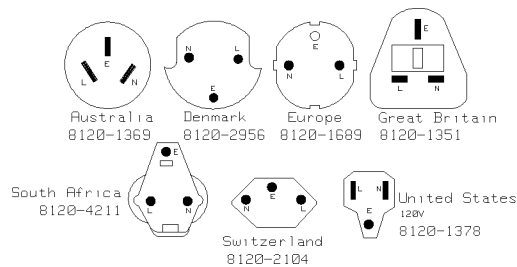

Figure A-1. Line Power Cables - Plug Identification

Warning

To avoid the possibility of injury or death, you must observe the following precautions before switching on the instrument.

- If this instrument is to be energized via an autotransformer for voltage reduction, ensure that the Common terminal connects to the earth pole of the power source.

A-2 Installation

- **Insert the power cable plug only into a socket outlet provided with a protective earth contact. Do not negate this protective action by the using an extension cord without a protective conductor.**
- **Before switching on the instrument, the protective earth terminal of the instrument must be connected to a protective conductor. You can do this by using the power cord supplied with the instrument.**
- **Do not interrupt the protective earth connection intentionally.**

The following work should be carried out by a qualified electrician. All local electrical codes must be strictly observed. If the plug on the cable does not fit the power outlet, or if the cable is to be attached to a terminal block, cut the cable at the plug end and rewire it.

The color coding used in the cable depends on the cable supplied. If you are connecting a new plug, it should meet the local safety requirements and include the following features:

- Adequate load-carrying capacity (see table of specifications).
- Ground connection.
- Cable clamp.

Warning **To avoid the possibility of injury or death, please note that the HP 8169A does not have a floating earth.**



Warning **The HP 8169A is not designed for outdoor use. To prevent potential fire or shock hazard, do not expose the instrument to rain or other excessive moisture.**



The AC power requirements are summarized on the rear panel of the instrument.

A



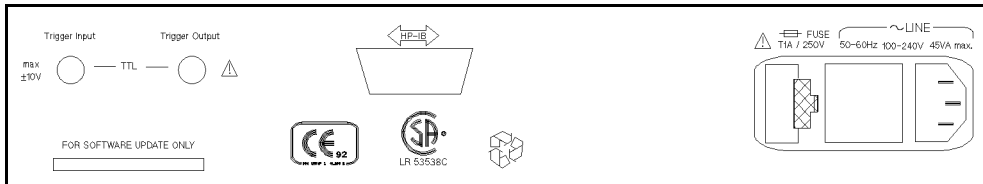

Figure A-2. Rear Panel Markings

Replacing the Fuse

There is one fuse in this instrument. This is a T1A/250V (time-lag) (HP Part No. 2110-0007). The fuse holder is at the rear of the instrument, beside the line power connector. To replace the fuse,

1. Release the fuse holder: use the blade of a flat-headed screwdriver to depress the catch at the side of the holder and then pull the holder out a little.

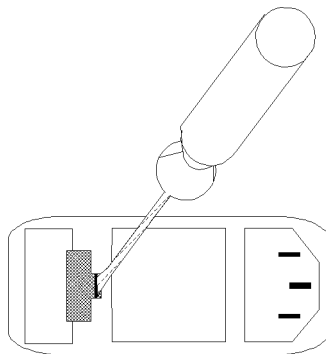

Figure A-3. Releasing the Fuse Holder

2. Pull the fuse holder out of the instrument.

A-4 Installation

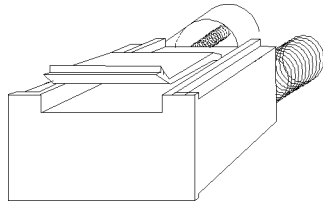

Figure A-4. The Fuse Holder

3. Check and replace the fuse as necessary making sure that the fuse is always in the top position of the fuse holder, and the bridge is in the bottom.
4. Place the fuse holder back in the instrument, and push it until the catch clicks back into place.

Replacing the Battery

This instrument contains a lithium battery. Replacing the battery should be carried out only by a qualified electrician or by HP service personnel.

There is a danger of explosion if the battery is incorrectly replaced. Replace only with the same or an equivalent type (HP part number 1420-0394). Discard used batteries according to local regulations.

Operating and Storage Environment

The following summarizes the HP 8169A operating environment ranges. In order for the polarization controller to meet specifications, the operating environment must be within these limits.

Warning



The HP 8169A is not designed for outdoor use. To prevent potential fire or shock hazard, do not expose the instrument to rain or other excessive moisture.

A

Temperature

Protect the instrument from temperature extremes and changes in temperature that may cause condensation within it.

The storage and operating temperature for the HP 8169A is given in the table below.

Table A-1. Temperature

	Operating Range	Storage Range
Specified	0°C to 55°C	-40°C to 70°C

Humidity

The operating humidity for the HP 8169A is 15% to 95% from 0°C to 40°C.

Altitude

The HP 8169A may operate at up to 10,000 feet.

Installation Category and Pollution Degree

The HP 8169A has Installation Category II and Pollution Degree 2 according to IEC 664.

Instrument Positioning and Cooling

Mount or position the instrument upright and horizontally so that air can circulate around it freely. When operating the polarization controller, choose a location that provides at least 75mm (3inches) of clearance at the rear, and at least 25mm (1inch) of clearance at each side. Failure to provide adequate air clearance may result in excessive internal temperature, reducing instrument reliability.

A

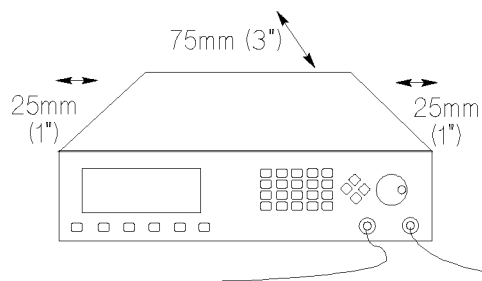

Figure A-5. Correct Positioning of the Polarization Controller

Switching on the Polarization Controller

When you switch on the polarization controller it goes through self test. This is the same as the self test described in “*TST?” in Chapter 6.

Optical Output

Caution



The polarization controller is supplied with either a straight contact connector (Option 021) or an angled contact connector (Option 022). Make sure that you only use the correct cables with your chosen output. See “Connector Interfaces and Other Accessories” in Appendix B for further details on connector interfaces and accessories.

A



Trigger Input and Output

The Trigger Input should be a standard TTL level signal. That is,

- True = Low = digital ground or 0Vdc to 0.4Vdc
- False = High = open or 2.5Vdc to 5Vdc

Caution A maximum of $\pm 10V$ can be applied as an external voltage to the Trigger Input BNC connector.



The Trigger Output is a standard TTL level signal.

Caution A maximum of between 0V and +5V can be applied as an external voltage to the Trigger Output BNC connector.



HP-IB Interface

You can connect your HP-IB interface into a star network, a linear network, or a combination star and linear network. The limitations imposed on this network are as follows:

- The total cable length cannot exceed 20 meters
- The maximum cable length per device is 2 meters
- No more than 15 devices may be interconnected on one bus.

A

Connector

The following figure shows the connector and pin assignments.

Connector Part Number: 1251-0293

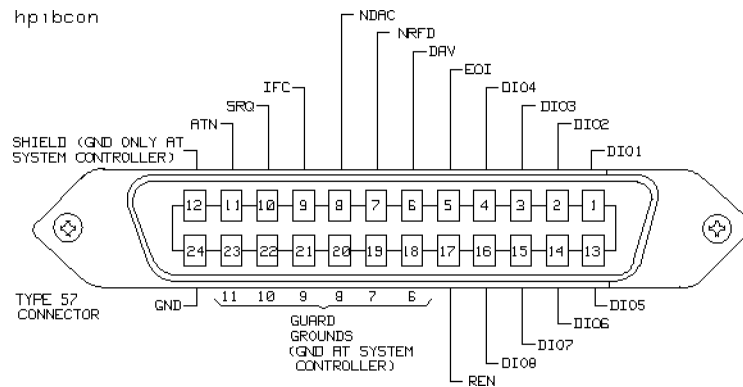

Figure A-6. HP-IB Connector

Caution



HP products delivered now are equipped with connectors having ISO metric- threaded lock screws and stud mounts (ISO M3.5×0.6) that are black in color. Earlier connectors may have lock screws and stud mounts with imperial-threaded lock screws and stud mounts (6-32 UNC) that have a shiny nickel finish.

Caution



- It is recommended that you do not stack more than three connectors, one on top of the other.
- Hand-tighten the connector lock screws. Do not use a screwdriver.

HP-IB Logic Levels

The polarization controller HP-IB lines use standard TTL logic, as follows:

- True = Low = digital ground or 0Vdc to 0.4Vdc
- False = High = open or 2.5Vdc to 5Vdc

All HP-IB lines have LOW assertion states. High states are held at 3.0Vdc by pull-ups within the instrument. When a line functions as an input, it requires

A



approximately 3.2mA to pull it low through a closure to digital ground. When a line functions as an output, it can sink up to 48mA in the low state and approximately 0.6mA in the high state.

Note The HP-IB line screens are not isolated from ground.



Claims and Repackaging

If physical damage is evident or if the instrument does not meet specification when received, notify the carrier and the nearest Hewlett-Packard Service Office. The Sales/Service Office will arrange for repair or replacement of the unit without waiting for settlement of the claim against the carrier.

Return Shipments to HP

If the instrument is to be shipped to a Hewlett-Packard Sales/Service Office, attach a tag showing owner, return address, model number and full serial number and the type of service required.

The original shipping carton and packing material may be reusable, but the Hewlett-Packard Sales/Service Office will provide information and recommendation on materials to be used if the original packing is no longer available or reusable. General instructions for repacking are as follows:

1. Wrap instrument in heavy paper or plastic.
2. Use strong shipping container. A double wall carton made of 350-pound test material is adequate.
3. Use enough shock absorbing material (3 to 4 inch layer) around all sides of the instrument to provide a firm cushion and prevent movement inside container. Protect control panel with cardboard.
4. Seal shipping container securely.
5. Mark shipping container FRAGILE to encourage careful handling.
6. In any correspondence, refer to instrument by model number and serial number.

A-10 **Installation**

Accessories

Instrument and Options

Mainframe Description	Model No.
Polarization Controller	HP 8169A
Pig-tailed fiber ports	Option 020
Straight, contact connectors	Option 021
Angled, contact connectors	Option 022
(Additional) Operating and Programming Manual	Option 0B2

HP-IB Cables and Adapters

The HP-IB connector is compatible with the connectors on the following cables and adapters.

- HP-IB Cable, 10833A, 1 m (3.3 ft.)
- HP-IB Cable, 10833B, 2 m (6.6 ft.)
- HP-IB Cable, 10833C, 4 m (13.2 ft.)
- HP-IB Cable, 10833D, 0.5 m (1.6 ft.)
- HP-IB Adapter, 10834A, 2.3 cm extender.



Connector Interfaces and Other Accessories

The polarization controller is supplied with one of three connector interface options.

Option 021, Straight Contact Connector

If you want to use straight connectors (such as FC/PC, Diamond HMS-10, DIN, Biconic, SC, ST, or D4) to connect to the instrument, you must

1. attach your connector interface (see the list of connector interfaces below) to the interface adapter,
2. then connect your cable.

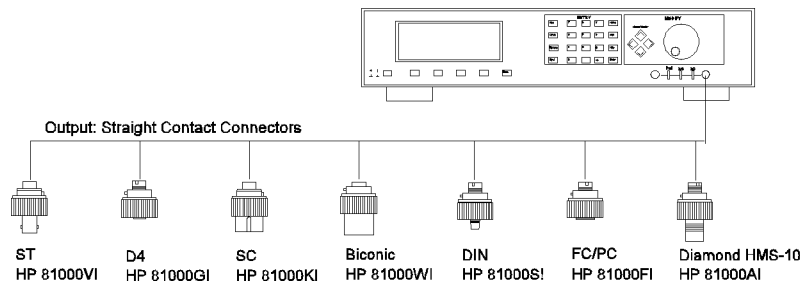

Figure B-1. Straight Contact Connector Configuration

Connector Interface	
Description	Model No.
Biconic	HP 81000WI
D4	HP 81000GI
Diamond HMS-10/HP	HP 81000AI
DIN 47256	HP 81000SI
FC/PC	HP 81000FI
SC	HP 81000KI
ST	HP 81000VI

B

B-2 Accessories

Option 022, Angled Contact Connector

If you want to use angled contact connectors (such as FC/APC, Diamond HRL-10, DIN, or SC/APC) to connect to the instrument, you must

1. attach your connector interface (see the list of connector interfaces below) to the interface adapter,
2. then connect your cable.

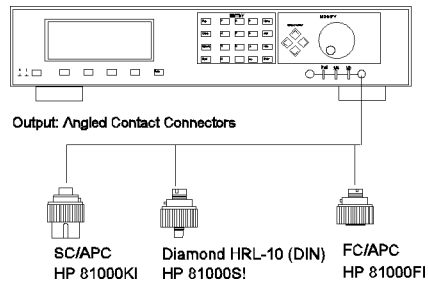

Figure B-2. Angled Contact Connector Configuration

Connector Interface	
Description	Model No.
Diamond HRL-10 (DIN)	HP 81000SI
FC/APC	HP 81000FI
SC/APC	HP 81000KI

B

Accessories B-3





Specifications

Specifications

Specifications describe the instrument's warranted performance over the 0°C to +55°C temperature range after a one hour warm up period. Characteristics provide information about non-warranted performance. Specifications are given in normal type, characteristics are given in *italicized* type. Spliced fiber pigtail interfaces are assumed for all cases, except where stated otherwise.

C

Description		HP 8169A
Operating Wavelength Range		1470 to 1570nm
Insertion Loss	Insertion Loss	< 1.5dB
Variation over 1 full rotation		$\leq \pm 0.03\text{dB}$ (Option 020)
Variation over complete wavelength range		$\leq \pm 0.1\text{dB}$
Polarization Extinction Ratio ¹		> 45dB (1530 to 1560nm) > 40dB (1470 to 1570nm)
Polarization Adjustment	Resolution	0.18° ² (360°/2048 encoder positions)
Fast axis alignment accuracy at home position ³		$\pm 0.2^\circ$ ²
Angular adjustment accuracy ³ (minimum step size)		$\pm 0.09^\circ$ ²
(greater than minimum step size)		$< \pm 0.5^\circ$ ²
<i>Settling time (characteristic)</i>		< 200ms
Memory Store/Recall registers		9
Angular repeatability after Store/Recall ³		$\pm 0.09^\circ$ ²
Number of scan rate settings		2
Maximum rotation rate ³		3600°/sec
Maximum Operating Input Power Limitation		+ 23dBm
<i>Operating Port Return Loss (characteristic)</i>		
<i>Individual reflections</i>		> 60dB
Power Requirements		48 to 60Hz 100/120/220/240V _{rms} 45VA _{max}
Weight		9kg (20lb)
Dimensions (H×W×D)		10×42.6×44.5cm 3.9×16.8×17.5in
¹ Extinction ration only refers to polarized portion of the optical signal. ² Guaranteed by design (DAC resolution) ³ Angles are mechanical rotation angles of the wave plates.		

C-2 Specifications

Other Specifications

Acoustic Noise Emission:

For ambient temperature up to 30°C

$L_p = 30 \text{ dB(A)}$

$L_w = 4.2 \text{ Bel}$

Typical operator position 35dBA

Normal operation <20dBA (<3.2Bel).

Data are results from type tests per ISO 7779(EN 27779).

Geräuschemissionswerte:

Bei einer Umgebungstemperatur bis 30°C

$L_p = 30 \text{ dB(A)}$

$L_w = 4.2 \text{ Bel}$

am Arbeitsplatz 35dBA

normaler Betrieb <20dBA (<3.2Bel).

Die Angabe ist das Ergebnis einer Typprüfung gemäß ISO 7779(EN 27779).

Declaration of Conformity

Manufacturer: Hewlett-Packard GmbH
Böblingen Instruments Division
Herrenberger Straße 130
D-71034 Böblingen
Federal Republic of Germany

We declare that the product

Product Name: Polarization Controller
Model Numbers: HP 8169A
Product Options: All

conforms to the following IEC-/EN- standards

Safety: IEC 1010-1(1990) including Addendum 1(1992), EN 61010 (1993)

EMC: EN 55011 (1991) / CISPR 11 Group 1, Class B
EN 50082-1 (1992)
IEC 801-2 ESD: 4 kV cd, 8 kV ad
IEC 801-3 Radiated Immunity: 3 V/m
IEC 801-4 Fast Transients: 0.5 kV, 1 kV

Supplementary Information:

During the measurements for EN 55011, the I/O ports were terminated with nominal impedance, the HP-IB connection was terminated with the cable HP 10833B.

When the product is connected to other devices, the user must ensure that the connecting cables and the other devices are adequately shielded to prevent radiation.

Böblingen, 9th June 1994

Hans Baisch
BID Regulations Consultant

D**D**

Performance Test

Use the Performance Test to verify the instruments warranted performance. Fiber Pigtails (option #020) are assumed for all cases. The tests also can be used as a pure functional tests for connectorized options #021 and #022, as no specifications and uncertainties can be given for these options.

Table D-1. Equipment used:

	8169A		
	#020 pigtail	#021 straight	#022 angled
HP 8168C #023 Tunable Laser Source	1	1	1
HP 8153A Lightwave Multimeter	1	1	1
HP 81533B Optical Head Interface	1	1	1
HP 81524A Optical Head	1	1	1
HP 81000DF Depolarizing Filter	1	1	1
HP 81000BA Bare Fiber Adapter	1	-	-
HP 81000FA FC/PC Connector Adapter	-	1	1
HP 81000SA DIN 47256 Connector Adapter	-	-	1
HP 81000AI Diamond HMS-10 Connector Interface	1	3	1
HP 81000FI FC/PC Connector Interface	2	1	1
HP 81000SI DIN 47256 Connector Interface	-	-	2
HP 81000UM Universal Through Adapter	2	1	1
SEIKO PC/PC adapter	-	1	1
HP 81109AC Diamond HMS-10/HP/HRL—Diamond HMS-10/HP Patchcord	1	1	1
HP 81101BC Diamond HMS-10/HP—Bare Fiber Patchcord	1	-	-
HP 81102BC Diamond HMS-10/HP/HRL—Bare Fiber Patchcord	1	-	-
HP 81101PC Diamond HMS-10/HP—PC Patchcord	1	2	-
HP 81102SC Diamond HMS-10/HP/HRL—DIN 47256/4108 Patchcord	-	-	1
HP 81113PC DIN 47256/4108—Super PC Patchcord	-	-	2
TECOS “IFOS-1560CW” Tunable Filter	1	1	1

D

Insertion Loss Variation with Rotation of $\lambda/4$ and $\lambda/2$ Plates

1. Make sure all the connectors you will be using are clean.
2. Set up the hardware as shown in Figure D-1.

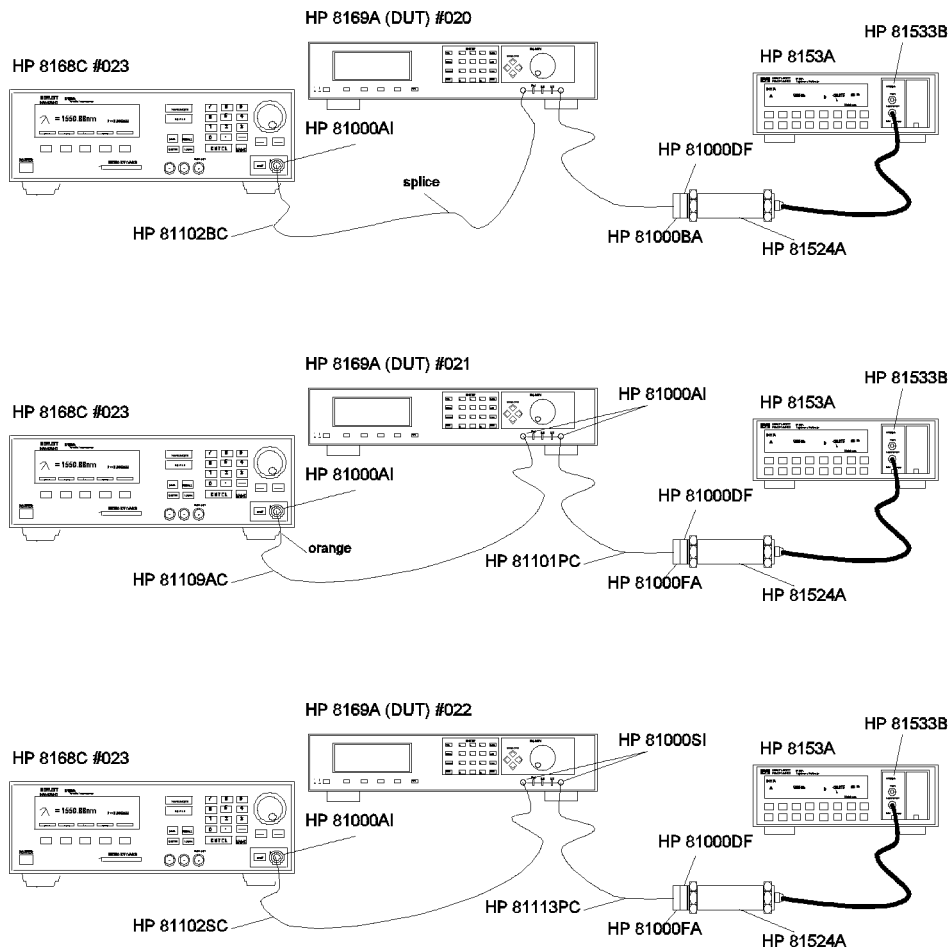

Figure D-1. Test Setup for Measuring the Insertion Loss

D-2 Performance Test

- For option #020 first splice a HP 81102BC patchcord to the pigtail of the Pol-port.
- Make sure that all instruments have warmed up.
- Fix all cables with tape so that they won't move during measurements.

3. Set up the 8153A.

- a. Zero the 8153A: press **ZERO**.
- b. Set the 8153A to dBm: press **dBm/W** until display shows dBm.
- c. Set the 8153A to wavelength = 1470 nm: press **param** until λ is shown, set λ to 1470 using the Modify keys.
- d. Set the 8153A sample time to 50 ms: press **param** until you get T, use the Modify keys, until display reads 50ms.
- e. Set 8153A to datalogging:
 - i. Press **Mode** to get MENU.
 - ii. Press **Record** until you get LOGGING.
 - iii. Press **Edit** to get SAMPLES.
 - iv. Press **Modify** cursor until display reads 500.
 - v. Press **Next** until you get START.
 - vi. Press **Modify** cursor until you get IMMEDIAT.
 - vii. Press **Edit** to get LOGGING.

4. Set up the 8168C.

- a. Press **Wavelength**, press **Edit**, type 1470 on the numeric keypad, press **Enter**.
- b. Press **Output Power**, press **Edit** type 100 on the numeric keypad, press **Enter**.
- c. Activate the Optical Output.

5. Set up the 8169A (DUT)

- a. Set the polarizing filter for maximum transmission (see "Setting the Position of the Polarizing Filter" in Chapter 2).
- b. Press **Sphere**, select SLOW with the Modify knob and press **Enter**.

D

- c. Press **Exec**.
6. Execute data logging.
 - a. On the 8153A press **Exec**.

The 8153A now takes the measurement samples. It will stop automatically when the 500 samples are taken.
7. Get measurement results, MIN/MAX readings:
 - a. Press **More** to get SHOW.
 - b. Press **Edit** to get MAXIMUM.
 - c. Note the displayed value in the test record.
 - d. Press **Next** to get MINIMUM.
 - e. Note the displayed value in the test record.
 - f. Press **Edit** to get SHOW.
8. Press **Record** until you get LOGGING.
9. Repeat list item 6 to list item 7 for wavelengths 1510nm, 1530nm and 1560nm.

To change the wavelength on the 8153A:

 - a. Press **Edit**, **Mode**, **Param** until λ appears.
 - b. Use the Modify keys to set the appropriate λ value.

To change the wavelength on the 8168A:

 - a. Press **Wavelength**, press **Edit**, type the wavelength on the numeric keypad, press **Enter**.

Always note the MAXIMUM and MINIMUM values in your test record.
10. Press **Mode** to get back to MEASURE Mode.
11. Calculate the difference between the “Maximum Power” and the “Minimum Power” as the result for “Insertion Loss Variation with rotation of $\lambda/4$ and $\lambda/2$ plates”.

D-4 Performance Test

Example

Test No.	Test Description	Minimum Spec.	Result			Maximum Spec.	Measurement Uncertainty
I.	Insertion Loss Variation with Rotation of $\lambda/4$ and $\lambda/2$ Plates						
	Wavelength		Maximum Power	Minimum Power	Difference		
	1470nm		-32.401dBm	-32.421dBm	0.020dB _{pp}	0.060dB _{pp}	
	1510nm		-32.510dBm	-32.539dBm	0.019dB _{pp}	0.060dB _{pp}	
	1540nm		-32.444dBm	-32.465dBm	0.021dB _{pp}	0.060dB _{pp}	
	1560nm		-32.506dBm	-32.526dBm	0.020dB _{pp}	0.060dB _{pp}	

D

Insertion Loss versus Wavelength

1. Make sure all the connectors you will be using are clean.
2. Set up the hardware as shown in Figure D-1.
 - For option #020 first splice a HP 81102BC patchcord to the pigtail of the Pol-port
 - Make sure that all instruments have warmed up.
 - Fix all cables with tape so that they won't move during measurements.
3. Set up the 8153A.
 - a. Zero the 8153A: press **[Zero]**.
 - b. Set 8153A to dBm : press **[dBm/W]** until display shows dBm.
 - c. Set 8153A to 1 sec measuring time: press **[Param]** until τ is shown, set τ to 200ms by using the Modify keys.
 - d. Set 8153A to wavelength= 1470 nm: press **[Param]** until λ is shown, set λ to 1470 by using the Modify keys.
4. Set up the 8168C.

D

- a. Press **Wavelength**, press **Edit**, type 1470.000 on the numeric keys, press **Enter**.
 - b. Press **Output Power**, press **Edit**, type 100 on the numeric keys, press **Enter**.
 - c. Activate the 8168A.
5. Set up the 8169A.
- a. Set 8169A to Pol=0 (home position): press **Home**.
 - b. Select the “Circle” application: press **Circle**.
6. Optimize transmission through 8169A:
- a. Set the polarizing filter for maximum transmission (see “Setting the Position of the Polarizing Filter” in Chapter 2).
 - b. On 8169A set to $2\varepsilon_B$ and get maximum displayed power on 8153A by turning knob.
 - c. On 8169A set to $2\theta_P$ and get maximum displayed power on 8153A by turning knob.

Repeat these two steps until absolute maximum on 8153A display is reached

Note



As the display shows negative values, the maximum displayed power is the smallest number displayed

7. Note the displayed value on 8153A in your test record in the column “Power after DUT” for the associated wavelength.
8. Repeat list item 6 to list item 7 for the wavelengths between 1480 to 1570 nm in steps of 10 nm, always setting the 8168A and the 8153A to the required wavelength for each setting.
9. Repeat list item 6 to list item 7 again for 1470 nm to ensure stability of measurement setup.
If your measured value is more than .01dB off the previous value, you need to fix your setup and repeat list item 3 to list item 8.
10. Connect the 8168A’s output to the 81524A Optical Head as shown in Figure D-2.

D-6 Performance Test

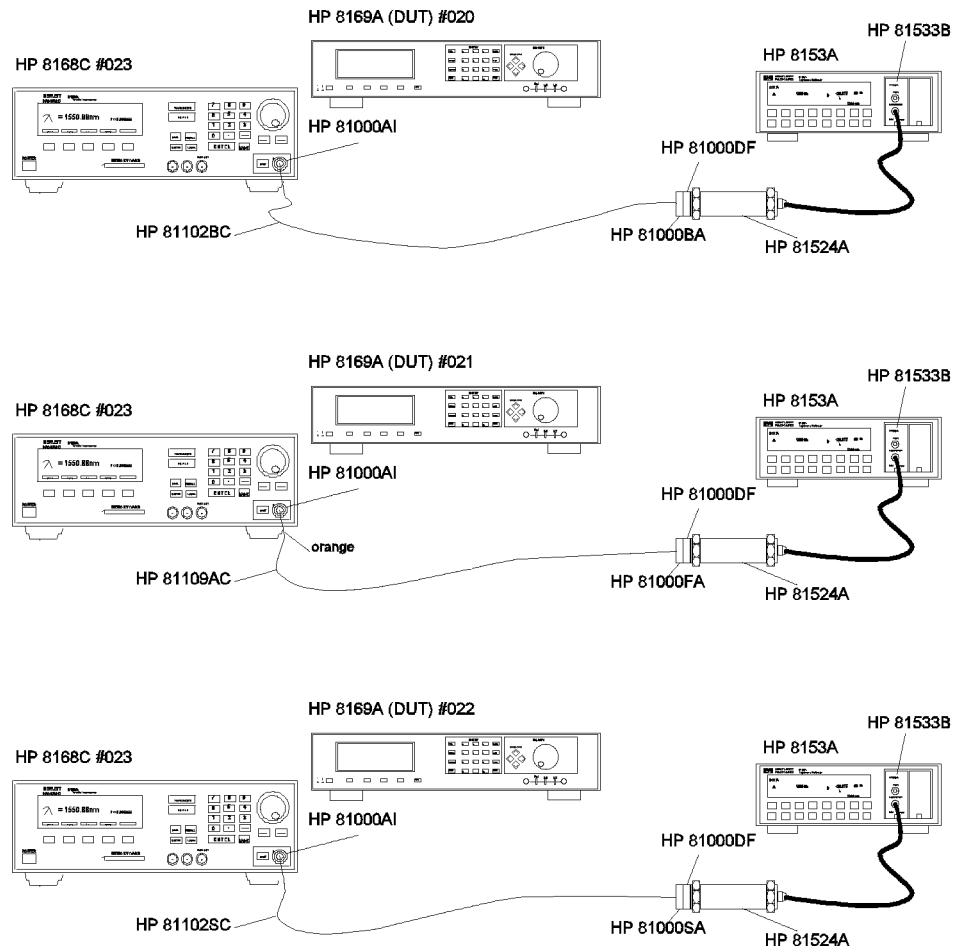

Figure D-2. Test Setup for Measuring the Reference Power

- If you're testing an option #020 you need to cut the spliced patchcords first
11. Set 8168A to the wavelength to 1470nm, Output Power to $100\mu\text{W}$.
 12. Set the 8153A to wavelength 1470nm.
 13. Note the displayed power on 8153A in your test records in the column "Reference Power" for the associated wavelength.

D

14. Repeat list item 11 to list item 13 for the wavelengths from 1480 to 1570nm in steps of 10nm, always setting the 8168A and the 8153A to the required wavelength.
15. Repeat list item 11 to list item 13 again for wavelength 1470 nm to ensure stability of measurement setup.
If your measured value is more than .01 dB off the previous value you need to fix your setup and repeat list item 11 to list item 15.
16. Calculate “Insertion Loss” as difference of “Reference Power”- “Power after DUT” and note the values in the associated column for each wavelength.
17. Check your calculations of “Insertion Loss” for the maximum and minimum value and note the values on the associated lines. The maximum value applies for Maximum Insertion Loss specification
18. Calculate the difference of maximum and minimum value as the result of “Variation of Insertion Loss with Wavelength”

D-8 Performance Test

Example

Test No.	Test Description	Minimum Spec.	Result			Maximum Spec.	Measurement Uncertainty
II.	Insertion Loss versus Wavelength						
	Wavelength		Reference Power	Power after DUT	Insertion Loss		
	1470nm		-30.240dBm	-31.590dBm	1.350dB		
	1480nm		-29.715dBm	-30.965dBm	1.250dB		
	1490nm		-29.960dBm	-31.326dBm	1.366dB		
	1500nm		-30.268dBm	-31.600dBm	1.332dB		
	1510nm		-28.872dBm	-30.188dBm	1.316dB		
	1520nm		-29.915dBm	-31.254dBm	1.339dB		
	1530nm		-30.431dBm	-31.727dBm	1.296dB		
	1540nm		-29.394dBm	-30.740dBm	1.346dB		
	1550nm		-29.601dBm	-30.934dBm	1.333dB		
	1560nm		-30.345dBm	-32.661dBm	1.316dB		
	1570nm		-30.133dBm	-31.466dBm	1.333dB		
			Maximum Insertion Loss		1.366dB	1.5dB	
			Minimum Insertion Loss		1.296dB		
			Difference		0.070dB _{PP}		
			= variation of insertion loss				
			with Wavelength		0.07dB _{PP}	0.2dB _{PP}	_____dB

D 

D

Extinction Ratio of Polarizer

1. Make sure all the connectors you will be using are clean.
2. Setup the equipment as shown in Figure D-3.

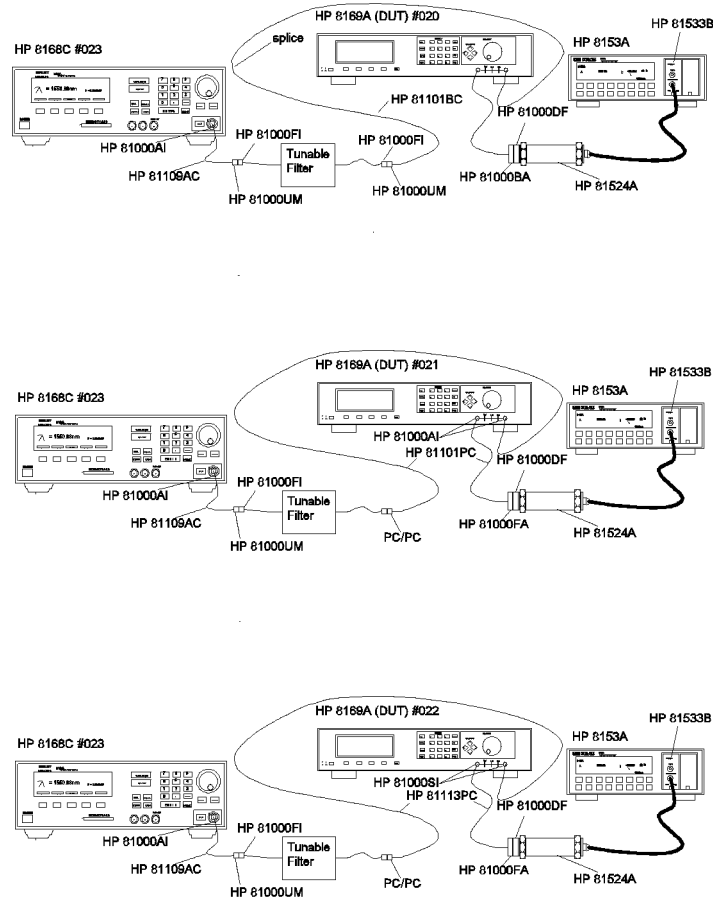

Figure D-3. Test Setup for Measuring the Extinction Ratio

- For option #020 first splice a HP 81101BC patchcord to the pigtail of the $\lambda/2$ -port
 - Make sure that all instruments have warmed up.
 - Fix all cables with tape so that they won't move during measurements.
3. Set up the 8153A:
 - a. Zero the 8153A: press **Zero**
 - b. Set 8153A to Auto ranging: press **Auto**
 - c. Set wavelength to 1470nm: press **Param** until λ appears use Modify keys to set the appropriate λ value.
 - d. Set display to dB: press **dB**
 - e. Set to averaging time 50ms: press **Param** until τ appears use Modify keys to set the appropriate T value.
 4. Set up 8168C:
 - a. Set wavelength to 1470nm : press **Wavelength**, type "1470", press **Enter**.
 - b. Set power to $400\mu W$: press **Output Power**, type "400", press **Enter**.
 - c. Activate Optical Output.
 5. Set up the 8169A:
 - a. Set to Home position: press **Home**
 6. Adjust the tunable filter to get maximum transmission: 8153A display shall show maximum reading (minimum value at negative sign).
 7. Set 8169A (DUT) to maximum transmission:
 - a. Set the polarizing filter for maximum transmission (see "Setting the Position of the Polarizing Filter" in Chapter 2).
 - b. Set 8169A (DUT) to Circle: press **Circle**
 - c. Select $2\theta_P$ and turn the knob to get maximum reading on 8153A display.
 - d. Select $2\varepsilon_B$ and turn knob to get maximum reading on 8153A display.
 8. On the 8153A: press **Disp->Ref**.
 9. Add 180 degrees to displayed value of $2\varepsilon_B$ and enter this value: type new value, press **Enter**
 10. Set 8169A (DUT) to minimum transmission:

D

- a. Select $2\theta_P$ and turn the knob to get minimum reading on 8153A display (maximum value at negative sign).
- b. Select $2\varepsilon_B$ and turn the knob to get minimum reading on 8153A display. You should repeat this step several times using the smallest step size when turning the knob.

The Extinction Ratio is the absolute maximum of any measured value (without the negative sign)

Note



The maximum measured value is one that might only occur momentarily and after several tries because of random position changes, that is, you need to approach the “minimum position” from both sides, for both parameters several times.

- 11. Note the measured result in your test record
- 12. Repeat list item 6 to list item 11 for 1510nm, 1530 nm and 1560 nm. Always change wavelength setting on all instruments of the test setup, and make sure to optimize the maximum transmission of the filter.

Example

Performance Test for the HP 8169A Option 020

Test No.	Test Description	Minimum Spec.	Result	Maximum Spec.	Measurement Uncertainty
III.	Extinction Ratio				
	Wavelength		Extinction Ratio		
	1470nm	40dB	43.5dB		
	1510nm	45dB	48.2dB		
	1530nm	45dB	50.6dB		
	1560nm	40dB	44.5dB		

Performance Test for the HP 8169A



Test Facility:

Report No. _____
Date _____
Customer _____
Tested By _____

Model HP 8169A Polarization Controller

Serial No.	_____	Ambient temperature	_____ °C
Options	_____	Relative humidity	_____ %
Firmware Rev.	_____	Line frequency	_____ Hz

Special Notes:

Performance Test for the HP 8169A Option 020

Page 2 of 5

D

Test Equipment Used:

Description	Model No.	Trace No.	Cal. Due Date
1. Tunable Laser Source	HP 8168C #023	_____	____/____/____
2. Lightwave Multimeter	HP 8153A	_____	____/____/____
3. Optical Head Interface	HP 81533B	_____	____/____/____
4. Optical Head	HP 81524A	_____	____/____/____
5. Depolarizing Filter	HP 81000DF		
6. Bare Fiber Adapter	HP 81000BA		
7. Diamond HMS-10 Connector Interface	HP 81000AI		
8. FC/PC Connector Interface	HP 81000FI (2 of)		
9. Universal Through Adapter	HP 81000UM (2 of)		
10. Diamond HMS-10/HP/HRL—Diamond HMS-10/HP Patchcord	HP 81109AC		
11. Diamond HMS-10/HP—Bare Fiber Patchcord	HP 81101BC		
12. Diamond HMS-10/HP/HRL—Bare Fiber Patchcord	HP 81102BC		
13. Diamond HMS-10/HP—PC Patchcord	HP 81101PC		
14. Tunable Filter	TECOS IFOS-1560CW		
15. _____	_____	_____	_____
16. _____	_____	_____	_____
17. _____	_____	_____	_____
18. _____	_____	_____	_____

D-14 Performance Test

Performance Test for the HP 8169A Option 020

D 

Model HP 8169A Polarization Controller Option 020 No. _____ Date _____

Test No.	Test Description	Minimum Spec.	Result			Maximum Spec.	Measurement Uncertainty
I.	Insertion Loss Variation with Rotation of $\lambda/4$ and $\lambda/2$ Plates						
	Wavelength		Maximum Power	Minimum Power	Difference		
	1470nm		_____dBm	_____dBm	_____dB _{PP}		0.060dB _{PP}
	1510nm		_____dBm	_____dBm	_____dB _{PP}		0.060dB _{PP}
	1540nm		_____dBm	_____dBm	_____dB _{PP}		0.060dB _{PP}
	1560nm		_____dBm	_____dBm	_____dB _{PP}		0.060dB _{PP}

Performance Test for the HP 8169A Option 020

Model HP 8169A Polarization Controller Option 020 No. _____ Date _____

Test No.	Test Description	Minimum Spec.	Result	Maximum Spec.	Measurement Uncertainty
II. Insertion Loss versus Wavelength					
	Wavelength		Reference Power	Power after DUT	Insertion Loss
	1470nm		_____dBm	_____dBm	_____dB
	1480nm		_____dBm	_____dBm	_____dB
	1490nm		_____dBm	_____dBm	_____dB
	1500nm		_____dBm	_____dBm	_____dB
	1510nm		_____dBm	_____dBm	_____dB
	1520nm		_____dBm	_____dBm	_____dB
	1530nm		_____dBm	_____dBm	_____dB
	1540nm		_____dBm	_____dBm	_____dB
	1550nm		_____dBm	_____dBm	_____dB
	1560nm		_____dBm	_____dBm	_____dB
	1570nm		_____dBm	_____dBm	_____dB
			Maximum Insertion Loss	_____dB	1.5dB
			Minimum Insertion Loss	_____dB	
			Difference	_____dB _{pp}	
			= variation of insertion loss with Wavelength	_____dB _{pp}	0.2dB _{pp} _____dB

Performance Test for the HP 8169A Option 020

D

Model HP 8169A Polarization Controller Option 020		No. _____		Date _____	
Test No.	Test Description	Minimum Spec.	Result	Maximum Spec.	Measurement Uncertainty
III. Extinction Ratio					
	Wavelength		Extinction Ratio		
	1470nm	40dB	_____dB		
	1510nm	45dB	_____dB		
	1530nm	45dB	_____dB		
	1560nm	40dB	_____dB		

Functional Test for the HP 8169A Option 021

Page 2 of 5

D

Test Equipment Used:

Description	Model No.	Trace No.	Cal. Due Date
1. Tunable Laser Source	HP 8168C #023	_____	____/____/____
2. Lightwave Multimeter	HP 8153A	_____	____/____/____
3. Optical Head Interface	HP 81533B	_____	____/____/____
4. Optical Head	HP 81524A	_____	____/____/____
5. Depolarizing Filter	HP 81000DF		
6. FC/PC Connector Adapter	HP 81000FA		
7. Diamond HMS-10 Connector Interface	HP 81000AI (3 of)		
8. FC/PC Connector Interface	HP 81000FI		
9. Universal Through Adapter	HP 81000UM		
10. PC/PC Through Adapter	Seiko		
11. Diamond HMS-10/HP/HRL—Diamond HMS-10/HP Patchcord	HP 81109AC		
12. Diamond HMS-10/HP—PC Patchcord	HP 81101PC (2 of)		
13. Tunable Filter	TECOS IFOS-1560CW		
14. _____	_____	_____	_____
15. _____	_____	_____	_____
16. _____	_____	_____	_____
17. _____	_____	_____	_____
18. _____	_____	_____	_____

D-18 Performance Test

Functional Test for the HP 8169A Option 021

D

Model HP 8169A Polarization Controller Option 021 No. _____ Date _____

Test No.	Test Description	Minimum Spec.	Result			Maximum Spec.	Measurement Uncertainty
I.	Insertion Loss Variation with Rotation of $\lambda/4$ and $\lambda/2$ Plates						
	Wavelength		Maximum Power	Minimum Power	Difference		
	1470nm		_____dBm	_____dBm	_____dB _{PP}		
	1510nm		_____dBm	_____dBm	_____dB _{PP}		
	1540nm		_____dBm	_____dBm	_____dB _{PP}		
	1560nm		_____dBm	_____dBm	_____dB _{PP}		

Functional Test for the HP 8169A Option 021

Page 4 of 5

Model HP 8169A Polarization Controller Option 021 No. _____ Date _____

Test No.	Test Description	Minimum Spec.	Result	Maximum Spec.	Measurement Uncertainty
II. Insertion Loss versus Wavelength					
	Wavelength		Reference Power	Power after DUT	Insertion Loss
	1470nm		_____dBm	_____dBm	_____dB
	1480nm		_____dBm	_____dBm	_____dB
	1490nm		_____dBm	_____dBm	_____dB
	1500nm		_____dBm	_____dBm	_____dB
	1510nm		_____dBm	_____dBm	_____dB
	1520nm		_____dBm	_____dBm	_____dB
	1530nm		_____dBm	_____dBm	_____dB
	1540nm		_____dBm	_____dBm	_____dB
	1550nm		_____dBm	_____dBm	_____dB
	1560nm		_____dBm	_____dBm	_____dB
	1570nm		_____dBm	_____dBm	_____dB
			Maximum Insertion Loss _____dB		
			Minimum Insertion Loss _____dB		
			Difference _____dB _{pp}		
			= variation of insertion loss with Wavelength _____dB _{pp}		_____dB

D-20 Performance Test

Functional Test for the HP 8169A Option 021

D

Model HP 8169A Polarization Controller Option 021		No. _____		Date _____	
Test No.	Test Description	Minimum Spec.	Result	Maximum Spec.	Measurement Uncertainty
III. Extinction Ratio					
	Wavelength		Extinction Ratio		
	1470nm		_____dB		
	1510nm		_____dB		
	1530nm		_____dB		
	1560nm		_____dB		

Functional Test for the HP 8169A Option 022

Page 2 of 5

D

Test Equipment Used:

Description	Model No.	Trace No.	Cal. Due Date
1. Tunable Laser Source	HP 8168C #023	_____	____/____/____
2. Lightwave Multimeter	HP 8153A	_____	____/____/____
3. Optical Head Interface	HP 81533B	_____	____/____/____
4. Optical Head	HP 81524A	_____	____/____/____
5. Depolarizing Filter	HP 81000DF		
6. FC/PC Connector Adapter	HP 81000FA		
7. DIN47256 Connector Adapter	HP 81000SA		
8. Diamond HMS-10 Connector Interface	HP 81000AI		
9. FC/PC Connector Interface	HP 81000FI		
10. DIN47256 Connector Interface	HP 81000SI (2 of)		
11. Universal Through Adapter	HP 81000UM		
12. PC/PC Through Adapter	Seiko		
13. Diamond HMS-10/HP/HRL—Diamond HMS-10/HP Patchcord	HP 81109AC		
14. Diamond HMS-10/HP/HRL—DIN 47256/4108 Patchcord	HP 81101SC		
15. DIN 47256/4108—Super PC Patchcord	HP 81113PC (2 of)		
16. Tunable Filter	TECOS IFOS-1560CW		
17. _____	_____	_____	_____
18. _____	_____	_____	_____

D-22 Performance Test

Functional Test for the HP 8169A Option 022

D

Model HP 8169A Polarization Controller Option 022 No. _____ Date _____

Test No.	Test Description	Minimum Spec.	Result			Maximum Spec.	Measurement Uncertainty
I.	Insertion Loss Variation with Rotation of $\lambda/4$ and $\lambda/2$ Plates						
	Wavelength		Maximum Power	Minimum Power	Difference		
	1470nm		_____dBm	_____dBm	_____dB _{PP}		
	1510nm		_____dBm	_____dBm	_____dB _{PP}		
	1540nm		_____dBm	_____dBm	_____dB _{PP}		
	1560nm		_____dBm	_____dBm	_____dB _{PP}		

Functional Test for the HP 8169A Option 022

Model HP 8169A Polarization Controller Option 022 No. _____ Date _____

Test No.	Test Description	Minimum Spec.	Result	Maximum Spec.	Measurement Uncertainty
II. Insertion Loss versus Wavelength					
	Wavelength		Reference Power	Power after DUT	Insertion Loss
	1470nm		_____dBm	_____dBm	_____dB
	1480nm		_____dBm	_____dBm	_____dB
	1490nm		_____dBm	_____dBm	_____dB
	1500nm		_____dBm	_____dBm	_____dB
	1510nm		_____dBm	_____dBm	_____dB
	1520nm		_____dBm	_____dBm	_____dB
	1530nm		_____dBm	_____dBm	_____dB
	1540nm		_____dBm	_____dBm	_____dB
	1550nm		_____dBm	_____dBm	_____dB
	1560nm		_____dBm	_____dBm	_____dB
	1570nm		_____dBm	_____dBm	_____dB
			Maximum Insertion Loss _____dB		
			Minimum Insertion Loss _____dB		
			Difference _____dB _{pp}		
			= variation of insertion loss with Wavelength _____dB _{pp}		_____dB

Functional Test for the HP 8169A Option 022

D

Model HP 8169A Polarization Controller Option 022		No. _____		Date _____	
Test No.	Test Description	Minimum Spec.	Result	Maximum Spec.	Measurement Uncertainty
III. Extinction Ratio					
	Wavelength		Extinction Ratio		
	1470nm		_____dB		
	1510nm		_____dB		
	1530nm		_____dB		
	1560nm		_____dB		



Cleaning Procedures

In general, *whenever possible use physically contacting connectors, and dry connections*. Fiber connectors may be used dry or wet. Dry means without index matching compound. If there is a need to use an index matching compound, use only HP index matching oil (part number 8500-4922). Clean the connectors, interfaces and bushings carefully each time after use.

Warning



Make sure to disable all sources when you are cleaning any optical interfaces.

Under no circumstances look into the end of an optical cable attached to the optical output when the device is operational.

The laser radiation is not visible to the human eye, but it can seriously damage your eyesight.

Cleaning Materials

	HP P/N
Lens Cleaning Paper	9300-0761
Special Cleaning Tips	9300-1351
Blow Brush	9300-1131
Adhesive Cleaning tape	15475-68701
Isopropyl Alcohol	Not available from HP. This should be available from any local pharmaceutical supplier.
Pipe Cleaner	

Cleaning Fiber/Front-Panel Connectors

1. To clean the instrument front panel connector remove the connector interface.
2. Apply some isopropyl alcohol to the lens cleaning paper and clean the surface and the ferrule of the connectors.
3. Using a new dry piece of cleaning paper, wipe the connector surface and ferrule until they are dry and clean.
4. Lightly press the adhesive tape several times against the connector surface to remove any remaining particles. After use store the tape in the container.
5. Protect the connector surface with a cap.

Cleaning Connector Interfaces

Note



If any index matching compound was used, use an ultrasonic bath with isopropyl alcohol to clean the connector interfaces.

- Apply some isopropyl alcohol to the pipe cleaner and wash the inside the connector interface.
- Using a new dry pipe cleaner, dry the inside the connector interface.
- Remove the brush part from the blow brush and blow air through the inside the interface to remove any remaining particles.

Cleaning Connector Bushings

As used on the HP 8158B Optical Attenuator and HP 81000AS/BS Optical Power Splitter.

Normally the connector bushings require no cleaning. However, if it appears that cleaning is necessary, use only the blow brush with the brush part removed.

Caution



- NEVER insert any cleaning tool into the bushing as this may affect the optical system.
 - NEVER use any index matching compound, cleaning fluid or cleaning spray.
-

E

Cleaning Detector Windows

As used on the HP 81520A and HP 81521B Optical Heads (large area).

1. Use the blow brush to remove any particles from the surface.
2. Wipe the surface with cleaning paper or special cleaning tips.

Cleaning Lens Adapters

Caution Do not use any cleaning fluid or cleaning spray.



-
1. Using the blow brush, remove dust.
 2. Wipe the surfaces with the special cleaning tips.

Cleaning Detector Lens Interfaces

As used on the HP 81522A Optical Head (small area) and HP 8140A and HP 8153A detector modules.

Normally, the lens interface can be cleaned by using the blow brush. If adhesive dirt must be removed perform as follows:

1. Using the blow brush, remove the dust from the lens surface.
2. Press the special cleaning tip to the lens surface and rotate the tip.

Note

Use alcohol for cleaning only then when above procedure does not help or if the dirt is caused by oil or fat.



F

Error Messages

Display Messages

F

Selftest Error **nnnn**. shows that the self test has failed. The number nnnn is a four digit hexadecimal number that shows which part of the self test has failed.

Bits	Mnemonics	Hexadecimal Value
14	Motor 3	8000 ₁₆
13	Motor 2	4000 ₁₆
12	Motor 1	1000 ₁₆
10	Counter 3	0400 ₁₆
9	Counter 2	0200 ₁₆
8	Counter 1	0100 ₁₆
5	DSP Timeout	0020 ₁₆
4	DSP Communications	0010 ₁₆
3	Calibration Data	0008 ₁₆
1	Battery RAM	0002 ₁₆
0	Calibration Data Checksum	0001 ₁₆

So Selftest Error 0010 would mean that the DSP (Digital Signal Processor) Communications had failed, Selftest Error 12 would mean that the DSP Communications had failed, and so had the Battery RAM. A value of zero shows no errors.

HP-IB Messages

Command Errors

These are error messages in the range -100 to -199. They show that a syntax error has been detected by the parser in a command, such as incorrect data, incorrect commands, or misspelled or mistyped commands.

A command error is signaled by the command error bit (bit 5) in the event status register.

-100 Command error. This shows that the parser has found a command error but cannot be more specific.

-101 Invalid character. The command contains an invalid or unrecognized character.

-102 Syntax error. The command or data could not be recognized.

-103 Invalid separator. The parser was expecting a separator (for example, a semicolon (;) between commands) but did not find one.

-104 Data type error. The parser was expecting one data type, but found another (for example, was expecting a string, but received numeric data).

-105 GET not allowed. A Group Execute Trigger was received within a program message (see IEEE 488.2, 7.7)

-108 Parameter not allowed. More parameters were received for a command than were expected.

-109 Missing parameter. Fewer parameters were received than the command requires.

-110 Command header error. A command header is the mnemonic part of the command (the part not containing parameter information. This error shows that the parser has found an error in the command header but cannot be more specific.

-111 Header separator error. A character that is not a valid header separator was encountered.

-112 Program mnemonic too long. The program mnemonic must be 12 characters or shorter.

F-2 Error Messages

-113 **Undefined header.** This header is not defined for use with the instrument.

-114 **Header suffix out of range.** The header contained an invalid character. This message sometimes occurs because the parser is trying to interpret a non-header as a header.

-120 **Numeric data error.** This error shows that the parser has found an error in numeric data (including nondecimal numeric data) but cannot be more specific.

-121 **Invalid character in number.** An invalid character was found in numeric data (note, this may include an alphabetic character in a decimal data, or a “9” in octal data).

-123 **Exponent too large.** The exponent must be less than 32 000.

-124 **Too many digits.** The mantissa of a decimal number can have a maximum of 255 digits (leading zeros are not counted).

-128 **Numeric data not allowed.** Another data type was expected for this command.

-130 **Suffix error.** The suffix is the unit, and the unit multiplier for the data. This error shows that the parser has found an error in suffix but cannot be more specific.

-131 **Invalid suffix.** The suffix is incorrect or inappropriate.

-134 **Suffix too long.** A suffix can have a maximum of 12 characters.

-138 **Suffix not allowed.** A suffix was found where none is allowed.

-140 **Character data error.** This error shows that the parser has found an error in character data but cannot be more specific.

-141 **Invalid character data.** The character data is incorrect or inappropriate.

-144 **Character data too long.** Character data can have a maximum of 12 characters.

-148 **Character data not allowed.** Character data was found where none is allowed.

-150 **String data error.** This error shows that the parser has found an error in string data but cannot be more specific.

F



-151 Invalid string data. The string data is incorrect, (for example, an END message was received before the terminal quote character).

-158 String data not allowed. String data was found where none is allowed.

-160 Block data error. This error shows that the parser has found an error in block data but cannot be more specific.

-161 Invalid block data. The block data is incorrect (for example, an END message was received before the length was satisfied).

-168 Block data not allowed. Block data was found where none is allowed.

F

F-4 Error Messages

Execution Errors

These are error messages in the range -200 to -299. They show that an execution error has been detected by the execution control block.

An execution error is signaled by the execution error bit (bit 4) in the event status register.

-200 Execution error. This shows that an execution error has occurred but the control block cannot be more specific.

-201 Invalid while in local. This command is invalid because it conflicts with the configuration under local control.

-202 Settings lost due to rtl. A local setting was lost when the instrument was changing from remote to local control, or from local to remote control.

-220 Parameter error. This shows that a parameter error has occurred but the control block cannot be more specific.

-221 Settings conflict. A valid parameter was received, but could not be used during execution because of a conflict with the current state of the instrument.

-222 Data out of range. The data, though valid, was outside the range allowed by the instrument.

-223 Too much data. The block, expression, or string data was too long for the instrument to handle.

-224 Illegal parameter value. One value from a list of possible values was expected. The parameter received was not found in the list.

-240 Hardware error. Shows that a command could not be executed due to a hardware error but the control block cannot be more specific.

-241 Hardware missing. Shows that a command could not be executed because of missing instrument hardware.

F

Device-Specific Errors

These are error messages in the range -300 to -399, or between 1 and 32767. They show that an error has been detected that is specific to the operation of the polarization controller.

A device-specific error is signaled by the device-specific error bit (bit 3) in the event status register.

-300 Device-specific error. This shows that a device-specific error has occurred. No more specific information is available.

-310 System error. An instrument system error has occurred.

-311 Memory error. A memory error has been detected.

-314 Save/recall memory lost. The nonvolatile data saved by the *SAV command has been lost.

-315 Configuration memory lost. The nonvolatile configuration data saved by the instrument has been lost.

-330 Self-test failed. Further information about the self-test failure is available by using *TST?.

-350 Queue overflow. The error queue has overflowed. This error is written to the last position in the queue, no further errors are recorded.

Query Errors

These are error messages in the range -400 to -499. They show that an error has been detected by the output queue control.

A device-specific error is signaled by the query error bit (bit 2) in the event status register.

-300 Query error. This shows that a query error has occurred. No more specific information is available.

-410 Query INTERRUPTED. A condition occurred that interrupted the transmission of the response to a query (for example, a query followed by a DAB or a GET before the response was completely sent).

-420 Query UNTERMINATED. A condition occurred that interrupted the reception of a query (for example, the instrument was addressed to talk and an incomplete program message was received).

-430 Query DEADLOCKED. A condition causing a deadlocked query has occurred (for example, both the input and the output buffer are full and the device cannot continue).

-440 Query UNTERMINATED after indefinite response. Two queries were received in the same message. The error occurs on the second query if the first requests an indefinite response, and was already executed.

F



