



OPERATING AND SERVICE MANUAL

MODEL 8013B PULSE GENERATOR

SERIAL NUMBERS

This manual applies directly to instruments with serial numbers prefixed **1441A**.

For additional information about serial numbers see INSTRUMENT AND MANUAL IDENTIFICATION in Section I.

© COPYRIGHT HEWLETT-PACKARD COMPANY/COLORADO SPRINGS DIVISION 1977
1900 GARDEN OF THE GODS ROAD, COLORADO SPRINGS, COLORADO, U.S.A.

ALL RIGHTS RESERVED

Manual Part Number 08013-90006
Microfiche Part Number 08013-90506

PRINTED: OCT 1977

SAFETY SUMMARY

The following general safety precautions must be observed during all phases of operation, service, and repair of this instrument. Failure to comply with these precautions or with specific warnings elsewhere in this manual violates safety standards of design, manufacture, and intended use of the instrument. Hewlett-Packard Company assumes no liability for the customer's failure to comply with these requirements.

GROUND THE INSTRUMENT.

To minimize shock hazard, the instrument chassis and cabinet must be connected to an electrical ground. The instrument is equipped with a three-conductor ac power cable. The power cable must either be plugged into an approved three-contact electrical outlet or used with a three-contact to two-contact adapter with the grounding wire (green) firmly connected to an electrical ground (safety ground) at the power outlet. The power jack and mating plug of the power cable meet International Electrotechnical Commission (IEC) safety standards.

DO NOT OPERATE IN AN EXPLOSIVE ATMOSPHERE.

Do not operate the instrument in the presence of flammable gases or fumes. Operation of any electrical instrument in such an environment constitutes a definite safety hazard.

KEEP AWAY FROM LIVE CIRCUITS.

Operating personnel must not remove instrument covers. Component replacement and internal adjustments must be made by qualified maintenance personnel. Do not replace components with power cable connected. Under certain conditions, dangerous voltages may exist even with the power cable removed. To avoid injuries, always disconnect power and discharge circuits before touching them.

DO NOT SERVICE OR ADJUST ALONE.

Do not attempt internal service or adjustment unless another person, capable of rendering first aid and resuscitation, is present.

DO NOT SUBSTITUTE PARTS OR MODIFY INSTRUMENT.

Because of the danger of introducing additional hazards, do not install substitute parts or perform any unauthorized modification to the instrument. Return the instrument to a Hewlett-Packard Sales and Service Office for service and repair to ensure that safety features are maintained.

DANGEROUS PROCEDURE WARNINGS.

Warnings, such as the example below, precede potentially dangerous procedures throughout this manual. Instructions contained in the warnings must be followed.

WARNING

**Dangerous voltages, capable of causing death, are present in this instrument.
Use extreme caution when handling, testing, and adjusting.**

TABLE OF CONTENTS

Section	Page
1 GENERAL INFORMATION	
1-1 Introduction	1-1
1-6 Specifications	1-3
1-8 Instrument and Manual Identification	1-3
2 INSTALLATION	
2-1 Initial Inspection	2-1
2-5 Claims for Damage	2-1
2-7 Repacking	2-1
2-9 Preparation for Use	2-2
2-12 Power Source Requirements	2-2
2-15 Temperature Requirements	2-2
2-17 Rack Mounting	2-2
3 OPERATING INSTRUCTIONS	
3-1 General	3-1
3-3 Output Formats	3-1
3-6 Internal 50 Ohm Load	3-1
3-8 Control Layout	3-1
3-11 Norm Operating Mode	3-2
3-13 Internal Trigger	3-2
3-18 External Trigger	3-4
3-23 Manual Trigger	3-5
3-28 Square Wave Mode	3-7
3-34 Gating Mode	3-9
3-38 RZ Mode	3-10
3-44 Double Pulse Mode	3-11
3-49 External Width Mode	3-13
3-54 Additional Facilities in RZ and Ext Width Modes	3-14
4 THEORY OF OPERATION	
4-1 Introduction	4-1
4-9 Repetition Rate Generator	4-2
4-12 Internal Rate Generator	4-2
4-14 External Trigger Operation	4-2
4-16 Manual Operation	4-2
4-18 Gating	4-2
4-20 Selector Circuits	4-2
4-26 Delay Generator	4-4
4-31 Width Generator	4-5
4-37 Output Amplifiers	4-5
4-43 Offsets and Attenuators	4-7
4-48 Power Supplies	4-7

TABLE OF CONTENTS (Cont'd)

Section		Page
5	MAINTENANCE	
5-1	General	5-1
5-4	Removal of Covers	5-1
5-6	Removal of Assemblies	5-1
5-8	Timing board – Assembly 5	5-1
5-10	Output board – Assembly 6	5-1
5-15	Mother board – Assembly 7	5-1
5-23	Equipment Required	5-1
5-25	Performance Tests	5-2
5-27	Internal Checks and Adjustments	5-2
5-29	Service Product Safety Check	5-2
6	DIAGRAMS AND REPLACEABLE PARTS	
6-1	Introduction	6-1
6-3	Ordering Information	6-1
6-4	General	6-1
7	BACKDATING	
7-1	Introduction	7-1
7-3	Change Sequence	7-1

LIST OF TABLES

Table	Title	Page
1-1	Specifications	1-2
5-1	Test Equipment and Accessories	5-3
5-2	Performance Test: Pulse Period	5-4
5-3	Performance Test: Pulse Delay	5-4
5-4	Performance Test: Pulse Width (greater than 1 μ s)	5-5
5-5	Performance Test: Minimum Pulse Width	5-5
5-6	Performance Test: Pulse Period Jitter	5-6
5-7	Performance Test: Pulse Delay Jitter	5-6
5-8	Performance Test: Pulse Width Jitter	5-7
5-9	Performance Test: Square Wave	5-7
5-10	Performance Test: Duty Cycle	5-8
5-11	Performance Test: Manual Operation	5-8
5-12	Performance Test: External Width Operation	5-9
5-13	Performance Test: RZ Operation	5-9
5-14	Performance Test: Gate Operation	5-10
5-15	Performance Test: External Trigger Operation	5-10
5-16	Performance Test: High Frequency Trigger Operation	5-11
5-17	Performance Test: Trigger Output	5-11
5-18	Performance Test: Preshoot, Overshoot and Ringing	5-12
5-19	Performance Test: Amplitude	5-12
5-20	Performance Test: DC Offset	5-13
5-21	Internal Checks and Adjustments – Power Supply	5-13
5-22	Internal Checks and Adjustments – Repetition Rate	5-14
5-23	Internal Checks and Adjustments – Delay and Width Timing	5-14
5-24	Internal Checks and Adjustments – Pulse Perturbation	5-15
5-25	Internal Checks and Adjustments – Double Pulse	5-16
5-26	Service Product Safety Check	5-18

LIST OF TABLES (Cont'd)

Table	Title	Page
6-1	Reference Designators	6-1
6-2	Diagram Notes	6-2
6-3	Manufacturers' Code	6-3
6-4	Frame Replaceable Parts List	6-5
6-5	Board A5 Replaceable Parts List	6-7
6-6	Board A6 Replaceable Parts List	6-13
6-7	Board A7 Replaceable Parts List	6-17
7-1	Manual Backdating Changes	7-1
7-2	Replacement for Table 6-4. Frame Replaceable Parts List	7-5
7-3	Replacement for Table 6-5. Board A5 Replaceable Parts List	7-6
7-4	Replacement for Table 6-6. Board A6 Replaceable Parts List	7-11
7-5	Replacement for Table 6-7. Board A7 Replaceable Parts List	7-14

LIST OF ILLUSTRATIONS

Figure	Title	Page
2-1	Power Cords	2-1
2-2	Selector settings for the nominal power line voltages	2-2
3-1	8013B Front and rear panels — Control identification diagram	3-0
3-2	Normal/Complement Outputs	3-1
3-3	Positioning of Controls	3-2
3-4	Initial Control Settings and Test Equipment	3-3
3-5	Normal Internal Trigger Mode — Block Diagram	3-3
3-6	Output Pulses in Normal Internal Trigger Mode	3-4
3-7	Normal External Trigger Mode — Block Diagram	3-5
3-8	Output Pulses in Normal External Trigger Mode	3-6
3-9	Normal Manual Trigger Mode — Block Diagram	3-6
3-10	Output Pulses in Normal Manual Trigger Mode	3-7
3-11	Normal Square Wave Mode — Block Diagram	3-8
3-12	Output Pulses in Square Wave Mode	3-8
3-13	Normal Gate Mode — Block Diagram	3-9
3-14	Output Pulses in Gate Mode	3-10
3-15	RZ Mode — Block Diagram	3-10
3-16	Output Pulses in RZ Mode	3-11
3-17	Double Pulse Mode — Block Diagram	3-12
3-18	Output Pulses in Double Pulse Mode	3-12
3-19	External Width Mode — Block Diagram	3-13
3-20	Output Pulses in External Width Mode	3-14
3-21	Independent Clock Generator in RZ/EXT WIDTH Modes — Block Diagram	3-14
4-1	8013B Pulse Generator — Block Diagram	4-0
4-2	Repetition Rate Generator — Block Diagram	4-1
4-3a	Normal Mode (including external trigger and rate mode)	4-2
4-3b	RZ Mode	4-3
4-3c	Ext Width Mode	4-3
4-3d	Square Wave Mode	4-4
4-4	Delay Generator — Block Diagram	4-4
4-5	Width Generator — Block Diagram	4-5
4-6	Output Amplifiers — Block Diagram	4-6
4-7	Offsets and Attenuators — Block Diagram	4-6

LIST OF ILLUSTRATION (Cont'd)

Figure	Title	Page
6-1	Assembly Diagram	6-4
6-2	Component Layout - Board A5	6-6
6-3	Component Layout - Board A6	6-12
6-4	Component Layout - Board A7 - Front View	6-16
6-5	Component Layout - Board A7 - Rear View	6-17
6-6	Repetition Rate Generator 8013B, Schematic 1	6-19
6-7	Mode Selector, Trigger Amplifier, Ext. Input and Square Wave Circuits 8013B, Schematic 2	6-21
6-8	Delay Generator 8013B, Schematic 3	6-23
6-9	Width Generator 8013B, Schematic 4	6-25
6-10	Output Amplifiers 8013B, Schematic 5	6-27
6-11	Offset and Attenuator 8013B, Schematic 6	6-29
6-12	Power Supplies 8013B, Schematic 7	6-31
7-1	Replacement for Figure 6-2. Component Layout - Board A5	7-4
7-2	Replacement for Figure 6-1. Assembly Diagram	7-15
7-3	Replacement for Figure 6-2. Component Layout - Board A5	7-16
7-4	Replacement for Figure 6-12. Power Supplies 8013B	7-17

1-1 INTRODUCTION

1-2 The 8013B is an extremely versatile, easy to operate pulse generator with a wide range of applications. It has a variable repetition rate of 0–50 MHz and transition times of $< 3.5\text{ns}$ which make it ideal for testing digital logic: HTL, RTL, DTL and most ECL can be tested. The simultaneous positive and negative outputs are useful for testing circuits with both positive and negative power supplies. Format changes from normal to complement can be made at the throw of a switch, without having to re-adjust any pulse parameters. This enables changes from positive to negative logic conventions to be made and 100% duty cycles to be obtained very easily.

1-3 The 8013B has a selectable source impedance which makes impedance matching to the circuit under test very simple. It also has a square wave facility that is independent of width and delay settings and a double pulse facility that is useful for testing device recovery times and making noise immunity measurements.

1-4 The front panel of the 8013B has been carefully designed to provide a logical layout of the controls; horizontal controls for pulse timing parameters, vertical controls for pulse amplitude parameters. Also, compatible pulse settings are guaranteed as long as the pulse delay and pulse width controls are either set to the left of the pulse period control or; if set vertically below the period control, that the delay and width verniers are set counterclockwise of the period vernier. This simple, straightforward design enables pulses to be set up extremely quickly and easily.

1-5 The 8013B will operate in three different modes as follows:

Normal mode: in this mode the internal rate generator determines the repetition rate of the output pulses. The generator can be triggered internally, externally or manually or can be gated. A trigger pulse is generated for each output pulse and the pulse output can be delayed with respect to the trigger output.

RZ mode: in this mode external pulses are applied to the input connector on the 8013 rear panel and these pulses trigger the delay generator directly, completely by-passing the internal rate generator. Thus the internal rate generator can be used separately in this mode to provide trigger pulses that are independent of the RZ output.

External width mode: in this mode external pulses applied to the input socket on the rear panel determine the width and repetition rate of the output pulses. In fact the output is a pulse-shaped version of the external input. The pulse available at the trigger output, being derived from the internal rate generator, is independent of the RZ output.

Table 1-1. Specifications

PULSE CHARACTERISTICS

Transition times: 3.5ns fixed with INT LOAD switched IN. < 5ns fixed with INT LOAD switched OUT.

Overshoot and ringing: < $\pm 5\%$ of pulse amplitude unless INT LOAD is switched OUT and amplitude reduced to 0.4V – 4V when it may increase to $\pm 10\%$.

Preshoot: < $\pm 5\%$ of pulse amplitude.

Pulse width: < 10ns to 1s in four ranges. Vernier provides continuous adjustment within ranges.

Width jitter: < 0.1% + 50ps on any width setting.

Maximum duty cycle: > 75% from 1 Hz to 10 MHz, decreasing to $\geq 40\%$ at 50 MHz. Up to 100% in COMPL mode.

Maximum output: with INT LOAD switched IN, output is 5V across 50 ohms, 10V across open circuit. With INT LOAD switched OUT, output is 10V across 50 ohms. Output circuit cannot be damaged by short circuits.

Attenuator: 4-step attenuator reduces output to 0.2V with INT LOAD switched IN, or to 0.4V with INT LOAD switched OUT. Vernier provides continuous adjustment within ranges.

Polarity: dual channel, positive and negative outputs simultaneously.

Output format: normal or complement selectable.

Source impedance: 50 ohms $\pm 3\%$ shunted by typically 20pF with INT LOAD switched IN. > 50 ohms shunted by typically 20pF with INT LOAD switched OUT.

DC offset: with INT LOAD switched IN, offset is $\pm 2.5V$ across 50 ohms and is independent of amplitude settings. With INT LOAD switched OUT, offset is automatically switched off.

Pulse delay: < 35ns to 1s (with respect to trigger output) in four ranges. Vernier provides continuous adjustment within ranges. Min. delay 17ns typical.

Delay jitter: < 0.1% + 50ps on any delay setting.

REPETITION RATE AND TRIGGER

Repetition rate: 1 Hz to 50 MHz in four ranges, continuous adjustment within ranges.

Period jitter: < 0.1% + 50ps on any rate setting.

Square wave: 0.5 Hz to 25 MHz in four ranges. Duty cycle 50% $\pm 5\%$ up to 1 MHz. At 25 MHz tolerance increases to $\pm 15\%$.

Double pulse: up to 25 MHz simulating 50 MHz.

Trigger output: > +1V across 50 ohms, 16ns ± 10 ns wide. Suitable for triggering another 8012B/13B.

EXTERNALLY CONTROLLED OPERATION**External Triggering**

Repetition rate: 0 to 50 MHz. For square wave output, frequency is divided by 2.

Trigger input: sinewaves > 1.7 p-p (about zero) or pulses > 0.8V either polarity with a width of > 7ns.

Maximum input amplitude: $\pm 7V$.

Delay: 25ns ± 8 ns between leading edge of trigger input and trigger output signals.

Input impedance: 50 ohms $\pm 10\%$, dc coupled.

Manual: front panel pushbutton for single pulse.

Gating

Synchronous gating: gating signal turns generator on. First trigger output pulse is coincident with leading edge of gate pulse. Last output pulse is always generated with normal width even if the gate pulse ends during the generation of the pulse.

Gate input: dc-coupled; voltage at open connector approx. +1.8V. Shorting current ≤ 12 mA. Input impedance approx. 160 Ω .

Table 1-1. Specifications (cont'd)

Gate input signal: voltage $> +1.5V$ or resistor $> 1K\Omega$ to ground enables rep. rate generator. Voltage $< +0.8V$ or resistor $< 160\Omega$ disables rep. rate generator. Gate input TTL compatible. Maximum input: $\pm 5V$.

External Width and RZ modes

External width: output pulse width determined by the width of the drive input signal. Amplitude selectable. Trigger pulses, produced by the internal rate generator, are independent of the output pulses.

RZ mode: external input signal switched directly to delay generator. Output pulse period determined by period of RZ input signal. Delay, width, amplitude and output formats are selectable. Trigger pulses, produced by internal rate generator, are independent of the output pulses.

Input signal: input impedance 50 ohms, dc coupled. Signal amplitude $> +1V$, maximum input $\pm 5V$. Width $> 7ns$.

GENERAL

Operating temperature range: $0^{\circ}C$ to $55^{\circ}C$.

Power: 100/120/220/240V +5%, -10%, 48 to 400 Hz, 100 VA max.

Weight: net 4 kg (8.8 lbs); shipping 6.5 kg (14.6 lbs).

Dimensions: 200mm wide, 142mm high, 330mm deep (7.9" x 5.6" x 13").

Accessories: 15179A Adapter frame; rackmount for two units.

1-6 SPECIFICATIONS

1-7 Table 1-1 is a complete list of the Model 8013B critical specifications that are controlled by tolerances. Any changes in specifications due to manufacturing, design, or traceability to the U.S. National Bureau of Standards are included in table 1-1 or on a manual change sheet included with this manual. The manual and manual change sheet (if any) supersede all previous information concerning specifications of the Model 8013B.

1-8 INSTRUMENT AND MANUAL IDENTIFICATION

1-9 Instrument identification by serial number is located on the rear panel. Hewlett-Packard uses a two-

section serial number consisting of a four-digit prefix and a five-digit suffix, separated by a letter designating the country in which the instrument was manufactured. (A=U.S.A.; G=West Germany; J=Japan; U=United Kingdom.)

1-10 This manual applies to instruments with a serial prefix number as shown on the title page. If changes have been made in the instrument since this manual was printed, a "Manual Changes" supplement supplies with the manual will define these changes. Be sure to record these changes in your manual. Backdating information in Section VII adapts the manual to instruments with serial numbers lower than that shown on the title page. Part numbers for the manual and the microfiche copy of the manual are also shown on the title page.

2-1 INITIAL INSPECTION

2-2 Inspect the instrument and accessories for physical damage and if damage is evident refer to paragraphs 2-5 to 2-8 for the recommended claim procedure and repacking information.

2-3 The 8013B is delivered complete with the following items.

ITEM	HP Stock Number
0.5A fuse for 220/240V operation	2110-0202
1A fuse for 100/120V operation	2110-0007

2-4 The power cord delivered with the 8013B will be one of the following:

2-5 CLAIMS FOR DAMAGE

2-6 If physical damage is evident or if the instrument does not meet specifications when received, notify the carrier and the nearest Hewlett-Packard Sales/Service Office. The Sales/Service Office will arrange for repair or replacement of the unit without waiting for settlement of the claim against the carrier.

2-7 REPACKING

2-8 If the instrument is to be shipped to a Hewlett-Packard Sales/Service Office, attach a tag showing owner, address, model and serial number and the repair required. The original shipping carton and packing material can be re-used but the Hewlett-Packard Sales/Service Office will also provide information and recommendations on materials to be used if the original packing is not available or re-usable.

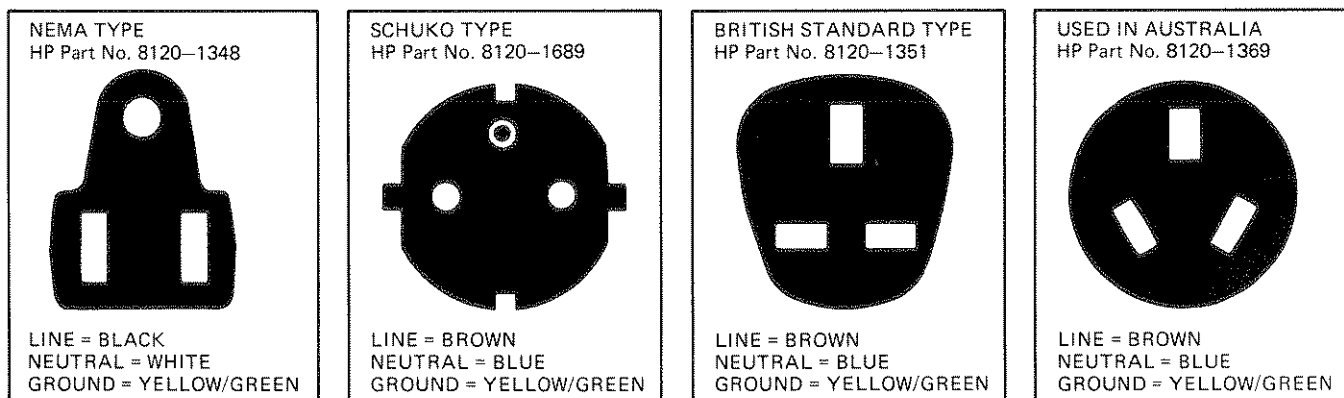

Figure 2-1. Power Cord

2-9 PREPARATION FOR USE

2-10 Power Cord

2-11 The 3-wire power cable supplied with the 8013B when connected to the appropriate power outlet, grounds the instrument cabinet and panels. To preserve this safety feature when operating the instrument from an outlet without a ground connection use an appropriate adapter and connect the ground lead (green/yellow) to an external ground.

2-12 POWER SOURCE REQUIREMENTS

2-13 The model 8013B will operate from nominal ac line supplies of 100V, 120V, 220V or 240V (-10%, +5%) at 48 Hz to 400 Hz. Two switches on the rear panel allow one of the four voltages to be selected.

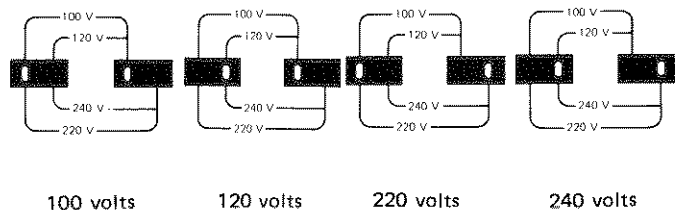

Figure 2-2. Selector settings for the nominal power line voltages

The power dissipation is 100VA max.

CAUTION

Before applying power to the instrument, check on the rear panel that the 8013B is set in accordance with local supply conditions (see para 2-13). If not, use a screwdriver to change the voltage selector positions. Insert the correct fuse into the fuse holder: 1A for 100/120 V Operation; 0.5A for 220/240 V Operation.

2-14 Connect the power cable to the rear connector.

2-15 TEMPERATURE REQUIREMENTS

2-16 The 8013B will operate within specifications when the ambient temperature is between 0°C (32°F) and 55°C (131°F). It can be stored at temperatures between -40°C (-40°F) and 75°C (167°C).

2-17 RACK MOUNTING

2-18 The 8013B can be mounted in a rack using the 15179A Adapter Frame. This frame has space for mounting either one or two 8013B pulse generators alongside each other in a rack.

10
11
12
13
14
15
16
17
18
19
20
21
22
23
24
25
26
27
28
29
30
31
32
33
34
35
36
37
38
39
40
41
42
43
44
45
46
47
48
49
50
51
52
53
54
55
56
57
58
59
60
61
62
63
64
65
66
67
68
69
70
71
72
73
74
75
76
77
78
79
80
81
82
83
84
85
86
87
88
89
90
91
92
93
94
95
96
97
98
99
100



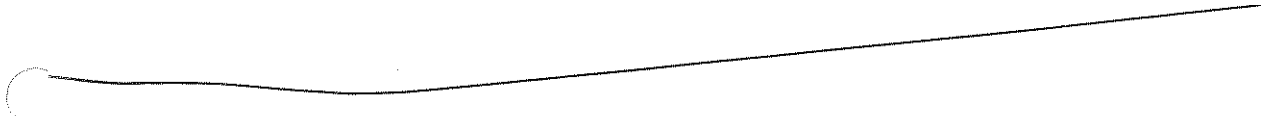

3-1 GENERAL

3-2 This section gives some general notes on the operation of the 8013B together with operating instructions for each of the operating modes:

NORM operating mode
RZ operating mode
EXT WIDTH operating mode

Full setting up instructions are given for normal internal trigger mode followed by any changes required in the control settings for the following modes. For ease of operation the instructions will refer to Figure 3-1 which shows the controls identified by a reference number in

a circle. The same reference numbers are used in the text when each control is mentioned. The control settings shown in Figure 3-1 are the same as the initial settings given for normal internal trigger mode.

3-3 OUTPUT FORMATS

3-4 The 8013B has two pulse outputs: one with positive (17) and one with negative (18) output polarity. The normal/complement output formats can be changed using the NORM/COMPL switch (19). Thus logic convention can be changed without having to re-adjust any of the pulse parameters.

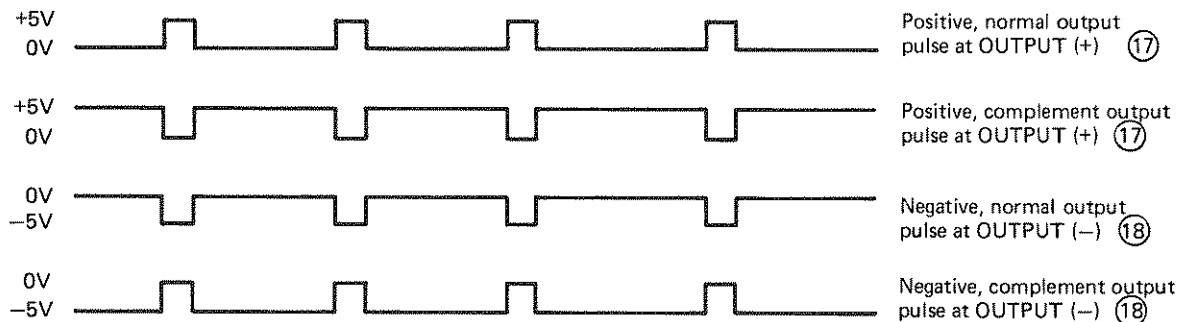

Figure 3-2. Normal/Complement Outputs

3-5 Normal/Complement pulse switching can be used to provide duty cycles of up to 100%.

Note, however, that the DC offset is automatically switched off when the INT LOAD is switched out.

3-6 INTERNAL 50 OHM LOAD

3-7 The internal 50 ohm load of the 8013B can be switched in or out using the INT LOAD switch (20). This makes impedance matching to the circuit under test much easier and also provides a maximum pulse amplitude of $\pm 10V$ with the load switched out.

3-8 CONTROL LAYOUT

3-9 The front panel of the 8013B has been carefully designed to provide a logical layout of the controls; horizontal controls for pulse timing parameters, vertical controls for pulse amplitude parameters. Thus a particular pulse can be set up extremely easily and quickly. Also, the pulse period, delay and width controls are designed in such a way that incompatible pulse settings will be noticed immediately (see Figure 3-3).

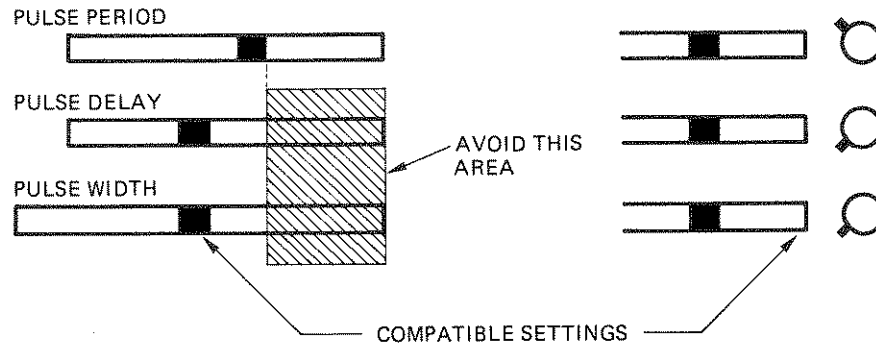

Figure 3-3. Positioning of Controls

3-10 Compatible pulse settings are guaranteed as long as the pulse delay and pulse width controls are either set to the left of the pulse period control or; if set vertically below the period control, that the delay and width verniers are set counter clockwise of the period vernier.

3-11 NORM OPERATING MODE

3-12 There are six ways of operating in the normal mode:

Internal trigger — the repetition rate is determined by the internal rate generator which is internally triggered.

External trigger — the rate generator is disabled and an external signal is used as the trigger source.

Manual trigger — one pulse is produced each time the MAN button is pressed.

Square wave — in each of the above modes a square wave output can be selected (pulse width = pulse period / 2) instead of the variable pulse width output.

Gating — Each of the outputs obtained above (except square wave) can be gated using an external input.

Double pulse — this mode can be selected with any of the above outputs (except square wave). Two pulses are produced for each trigger pulse.

All output pulses are preceded by a trigger pulse at the TRIGGER output connector (21). In square wave mode the delay between the trigger output and the pulse outputs is fixed at 25 ± 8 ns, but in other modes the delay can be varied using the PULSE DELAY (5) and VERNIER (6) controls.

3-13 Internal Trigger

3-14 In this mode the 8013B requires no external signal to produce an output signal. Rate, delay, width, amplitudes etc. are all adjustable from the front panel controls. The initial control settings (also shown in Figure 3-1) are given to assist someone unfamiliar with the operation of the 8013B. The positive and negative pulse outputs (17) and (18) and the TRIGGER OUTPUT (21) should be connected to an oscilloscope using a 50 ohm system (as shown in Figure 3-4). The oscilloscope (an HP 180C mainframe with 1801A and 1821A plug-ins) should be set with the sweep time at $20 \mu\text{s}/\text{div}$ and the sensitivity at $2\text{V}/\text{div}$.

- PULSE PERIOD ② .1m-10m
- VERNIER ③ CCW
- PULSE DOUBLE/NORM ④ NORM
- PULSE DELAY ⑤ 1μ-1m
- VERNIER ⑥ CCW
- PULSE WIDTH ⑦ 1μ-1m
- VERNIER ⑧ Center
- AMPLITUDE ⑨ 2.0-5.0
- VERNIER ⑩ CW
- OFFSET VERNIER ⑪ Center
- OFFSET SWITCH ⑫ ON
- AMPLITUDE ⑬ 2.0-5.0
- VERNIER ⑭ CW
- OFFSET VERNIER ⑮ Center
- OFFSET SWITCH ⑯ ON
- NORM/COMPL ⑰ NORM
- INT LOAD ⑱ IN
- Mode selector ⑳ NORM
- LINE ㉔ ON

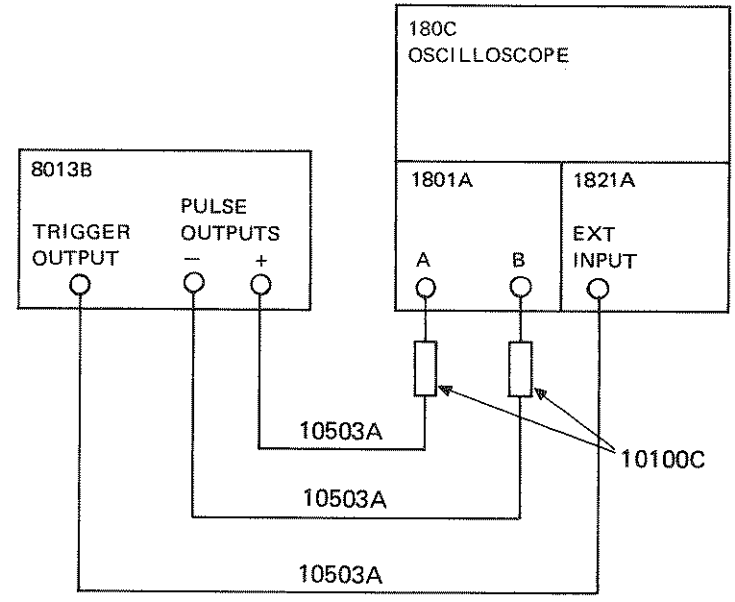

Figure 3-4. Initial control settings and test equipment

3-15 The circuits and controls involved in normal internal trigger mode are shown in Figure 3-5.

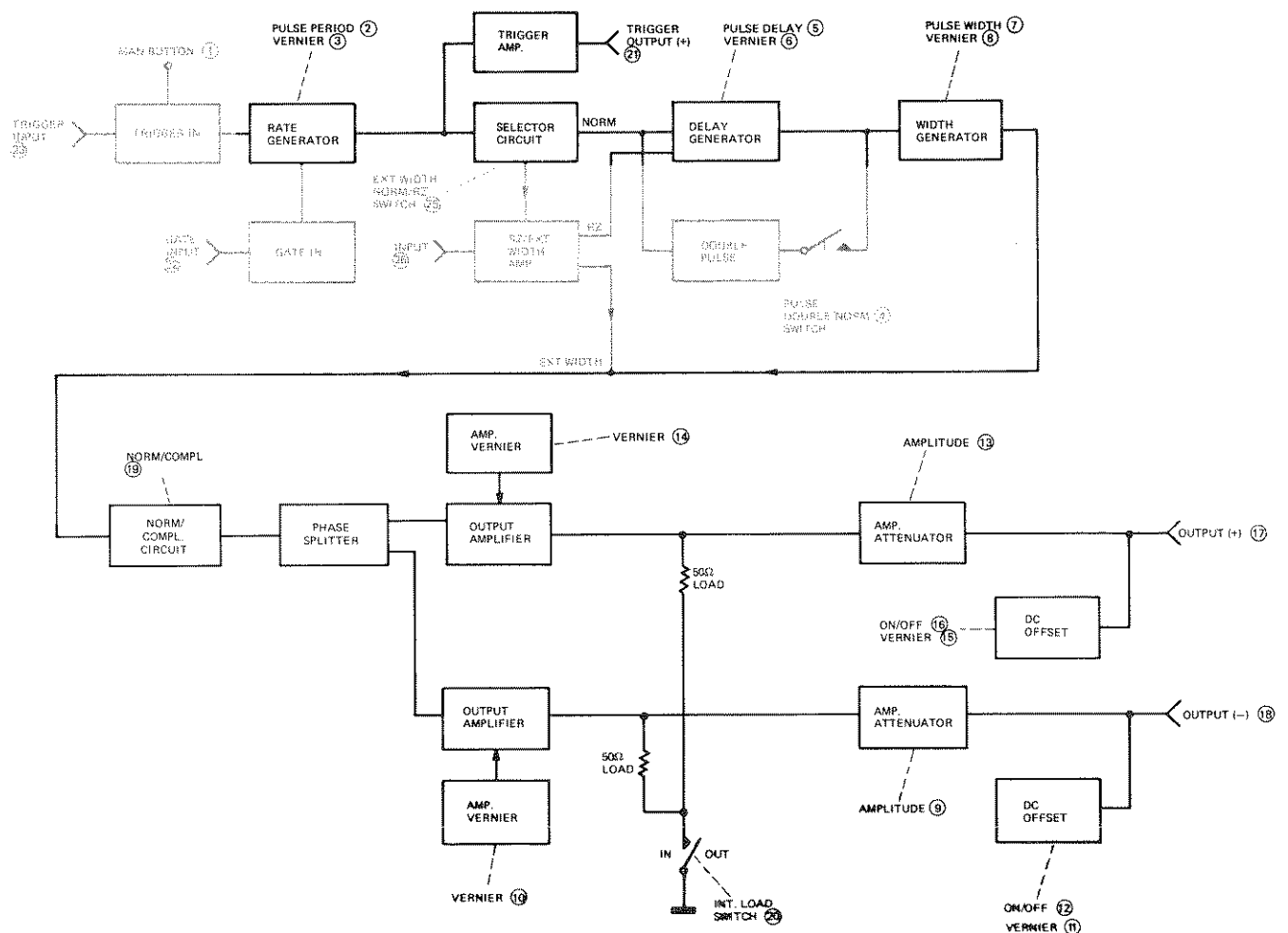

Figure 3-5. Normal internal trigger mode - block diagram

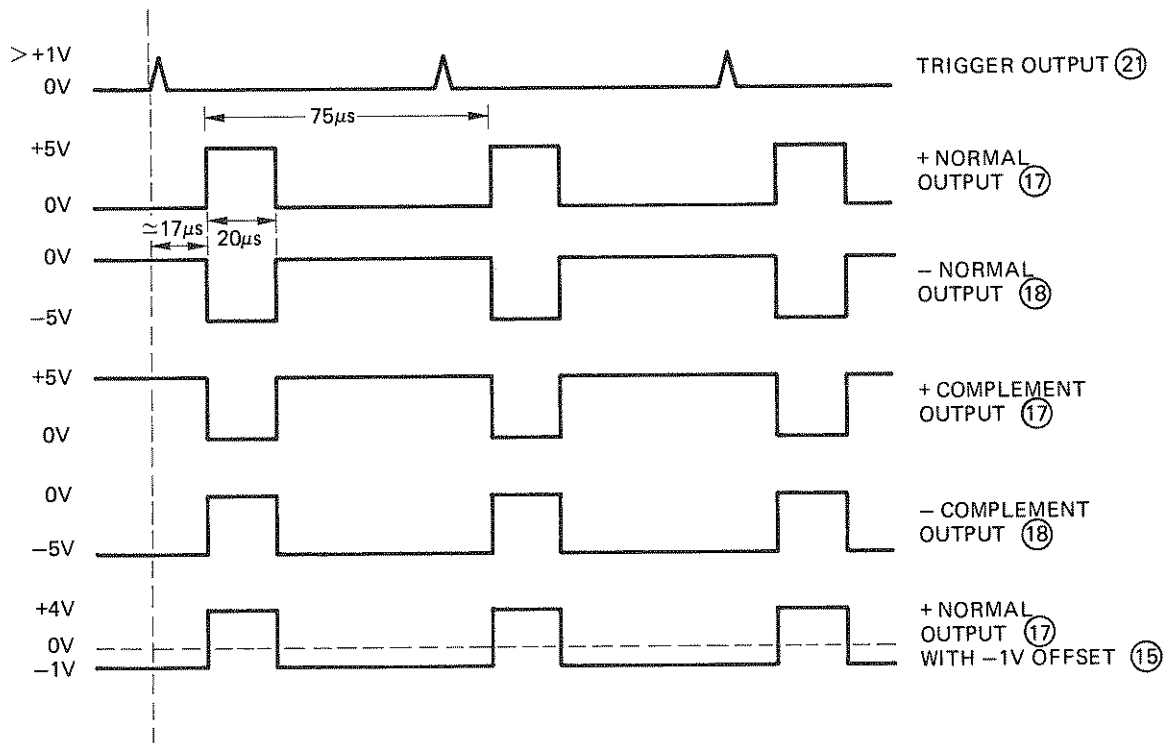

Figure 3-6. Output pulses in normal internal trigger mode

3-16 The output pulses should appear at the pulse OUTPUT (+) (17) and pulse OUTPUT (-) (18) as shown in Figure 3-6 according to the setting of the NORM/COMPL switch (19) and the OFFSET verniers (11) and (15)

3-17 If the INT LOAD switch (20) is set to OUT, the internal 50 ohm loads on each of the output amplifiers are switched out and the amplitude of the output pulses doubles (this can only be done if the 8013B has an external 50 ohm load). All other pulse parameters remain the same.

3-18 External Trigger

3-19 In this mode the repetition rate generator is disabled and each trigger pulse is produced by an

external signal which is applied at the TRIGGER INPUT connector (23). The input signal can be a sine wave of $> 1.7V$ p-p (about zero) or pulses $> 0.8V$ amplitude (positive or negative) and at least 7ns wide. The amplitude must not exceed $\pm 7V$.

a. Set the PULSE PERIOD control (2) to EXT (+) to trigger on the positive going slope of the input or to EXT(-) to trigger on the negative going slope.

b. The pulse delay, width, amplitude, etc. are determined by the front panel controls and can be left at the same settings as for normal internal trigger mode.

3-20 The circuits and controls involved in normal external trigger mode are shown in Figure 3-7.

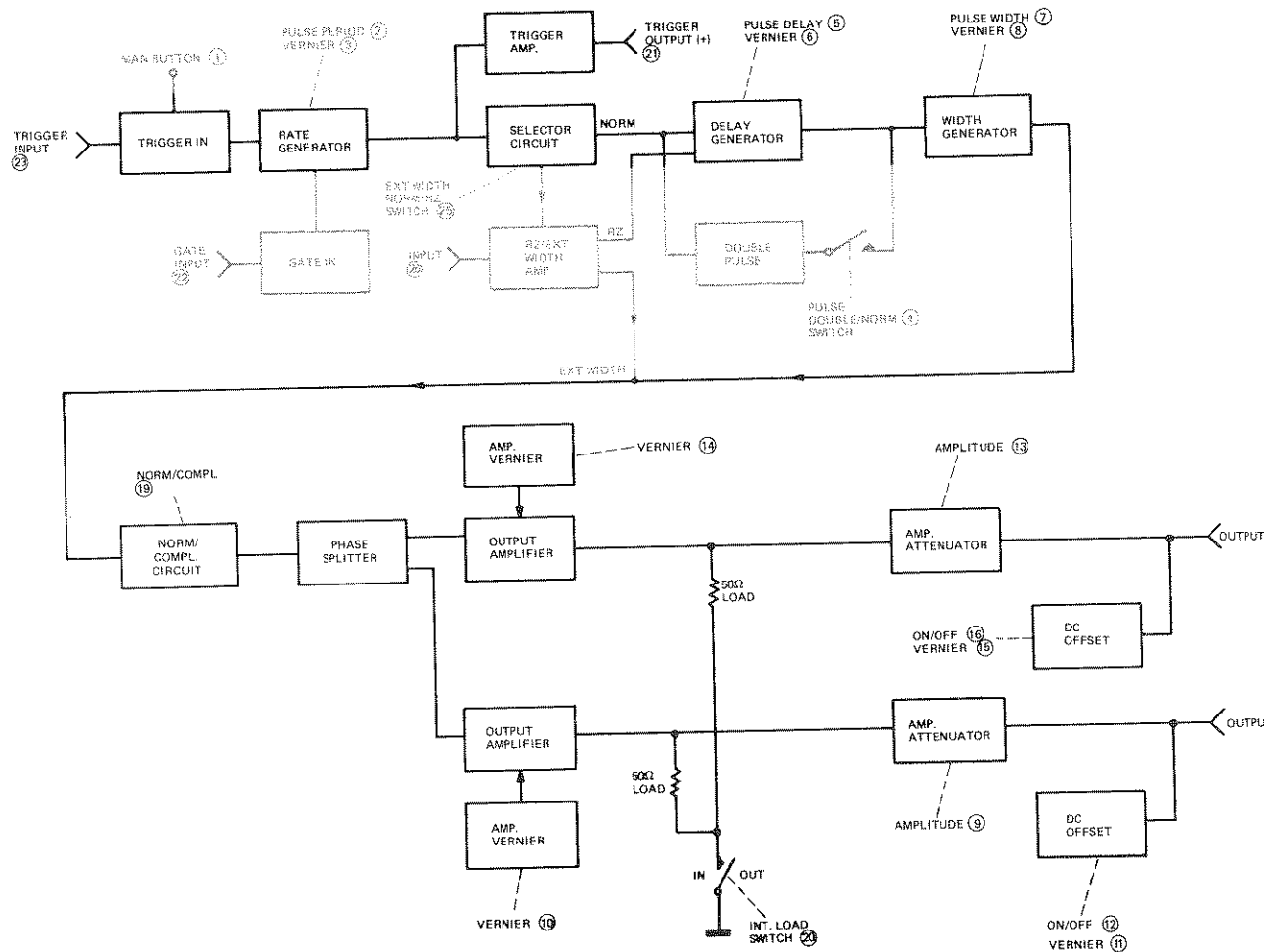

Figure 3-7. Normal external trigger mode – Block diagram

3-21 The output pulses should appear at the TRIGGER OUTPUT (21) and OUTPUT (+) (17) connectors as shown in Figure 3-8, according to the applied trigger and the setting of the PULSE PERIOD control (2) (either EXT+ or EXT-).

3-22 The output pulse parameters and formats can be varied using the controls shown in Figure 3-7.

3-23 Manual Trigger

3-24 In this mode the repetition rate generator is again disabled and each trigger pulse is produced by pressing the MAN button (1) once.

a. Set the PULSE PERIOD control (2) to either EXT(+) or EXT(-).

b. The pulse delay, width, amplitude etc. determined by the front panel controls can be left at the same settings as for normal internal trigger mode.

c. Press the MAN button (1) once for each output pulse.

3-25 The circuits and controls involved in normal manual trigger operation are shown in Figure 3-9.

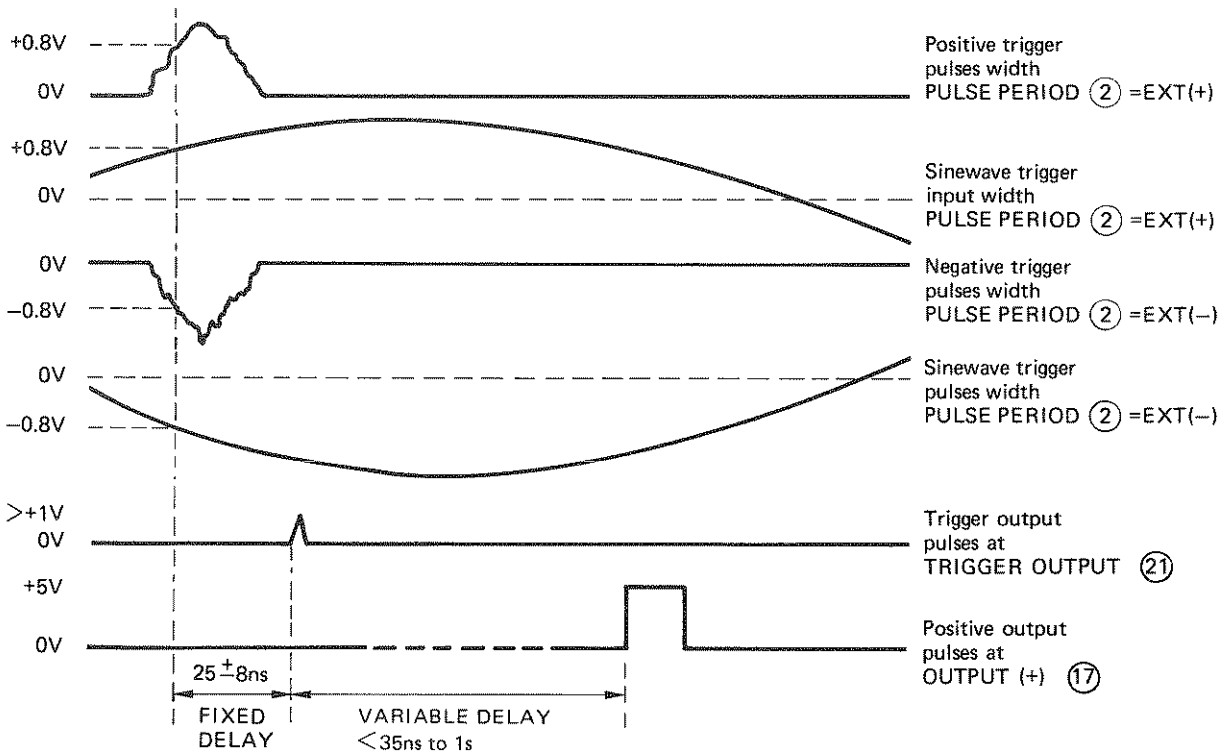

Figure 3-8. Output pulses in normal external trigger mode

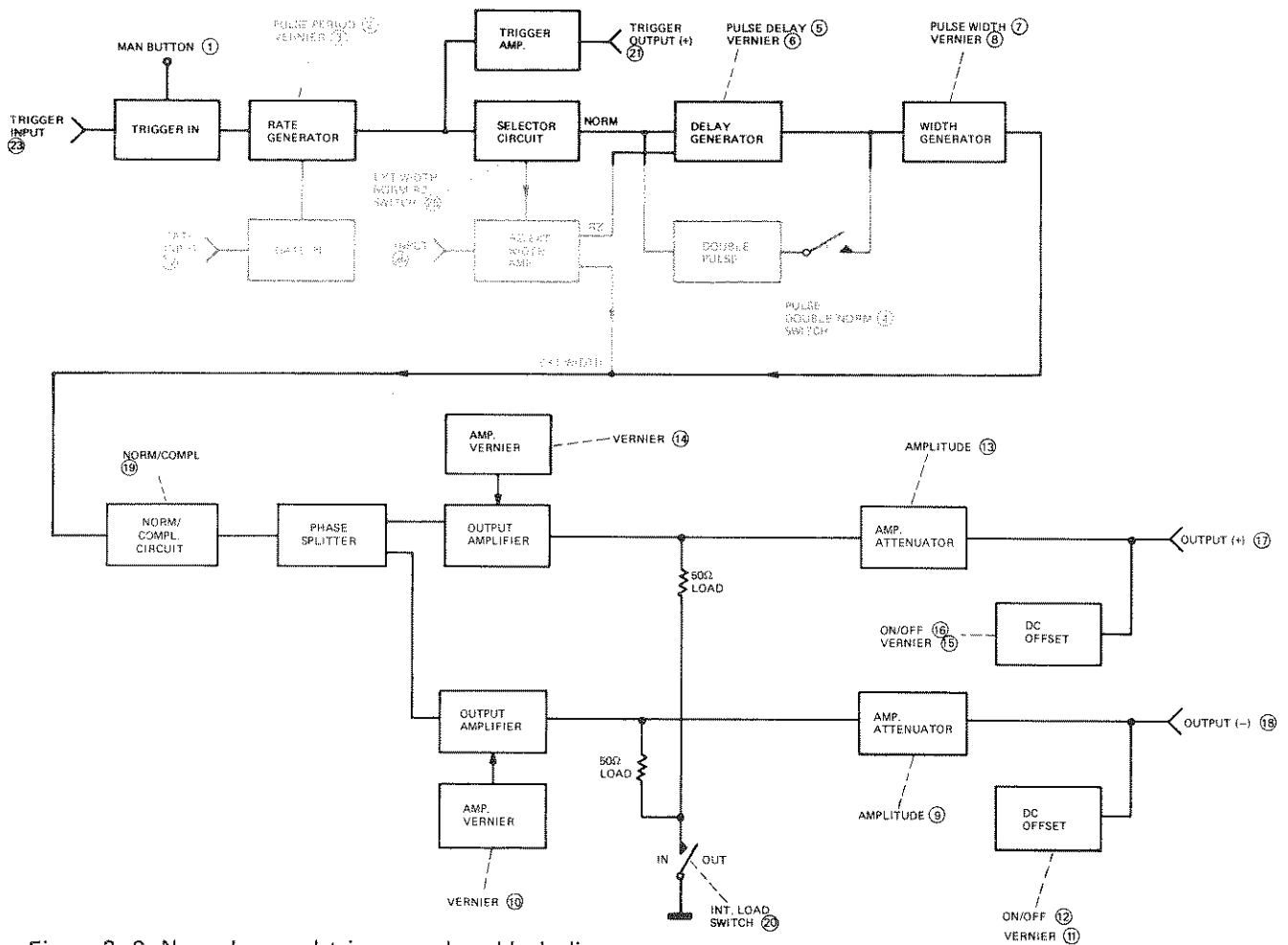

Figure 3-9. Normal manual trigger mode - block diagram

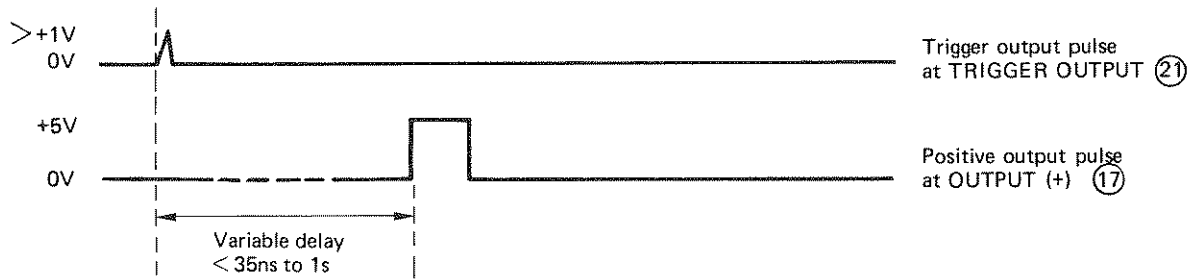

Figure 3-10. Output pulses in normal manual trigger mode

3-26 The output pulses should appear at the TRIGGER OUTPUT (21) and OUTPUT (+) (17) connectors as shown in Figure 3-10.

3-27 The output pulse parameters and formats can be varied using the controls shown in Figure 3-9.

3-28 Square Wave Mode

3-29 In this mode the pulse width is exactly half the pulse period (50% duty cycle). Pulse period, delay amplitude etc. can still be varied using the front panel controls. A square wave output can be selected in any of the preceding operating modes; the following points must, however, be remembered.

- a. Output pulse has 50% duty cycle.
- b. Output pulse rate is half that of the rate generator (or input trigger pulse).
- c. The delay between input trigger pulse and square wave output is fixed.

d. The output pulse is symmetrical above and below the offset level.

e. Square wave output cannot be gated.

3-30 The square wave output can be produced as follows:

a. Set the PULSE PERIOD control (2) to an internal range (as in normal internal trigger mode) or to EXT and apply external trigger pulses at the TRIGGER INPUT connector (23) in order to determine the repetition rate of the output pulses.

b. Set the PULSE WIDTH control (7) to SQUARE WAVE.

c. Set the amplitude etc. of the output pulse as for normal internal trigger mode.

3-31 The circuits and controls involved in square wave mode are shown in Figure 3-11.

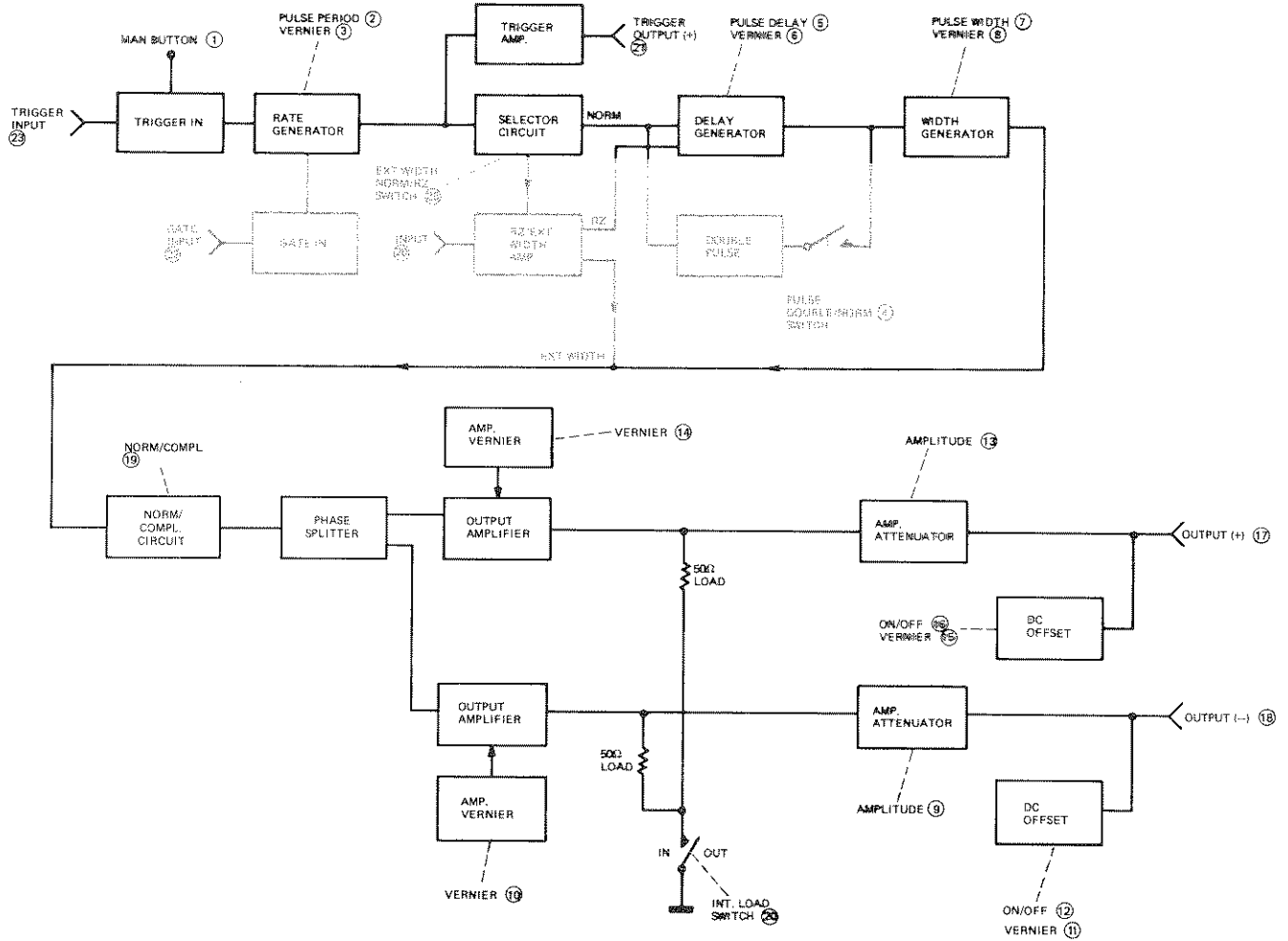

Figure 3-11. Normal square wave mode – block diagram

3-32 The output pulses should appear at the OUTPUT (+) connector (17) as shown in figure 3-12.

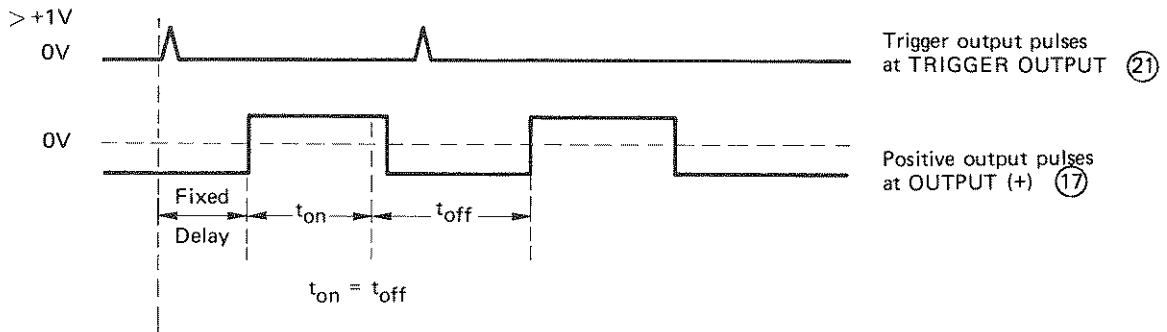

Figure 3-12. Output pulses in square wave mode

3-33 The output pulse can be switched to negative or normal or complement and the offset and amplitude can be varied.

to enable the rate generator – input voltage > +1.5V or resistor > 1KΩ from gate input to ground.

3-34 Gating Mode

to disable the rate generator – input voltage < +0.8V or resistor < 160Ω from gate input to ground.

3-35 The output pulses obtained in any of the preceding operating modes can be gated by applying an appropriate pulse to the GATE INPUT (22). If square wave mode is gated, the level of the pulse baseline after the gate has closed depends on the number of pulses during the gate 'on' time (see figure 3-15). The gate input must meet the following requirements:

The gate input is TTL compatible and the input voltage must not exceed ± 5V.

3-36 The circuits and controls involved in gate mode are shown in Figure 3-13.

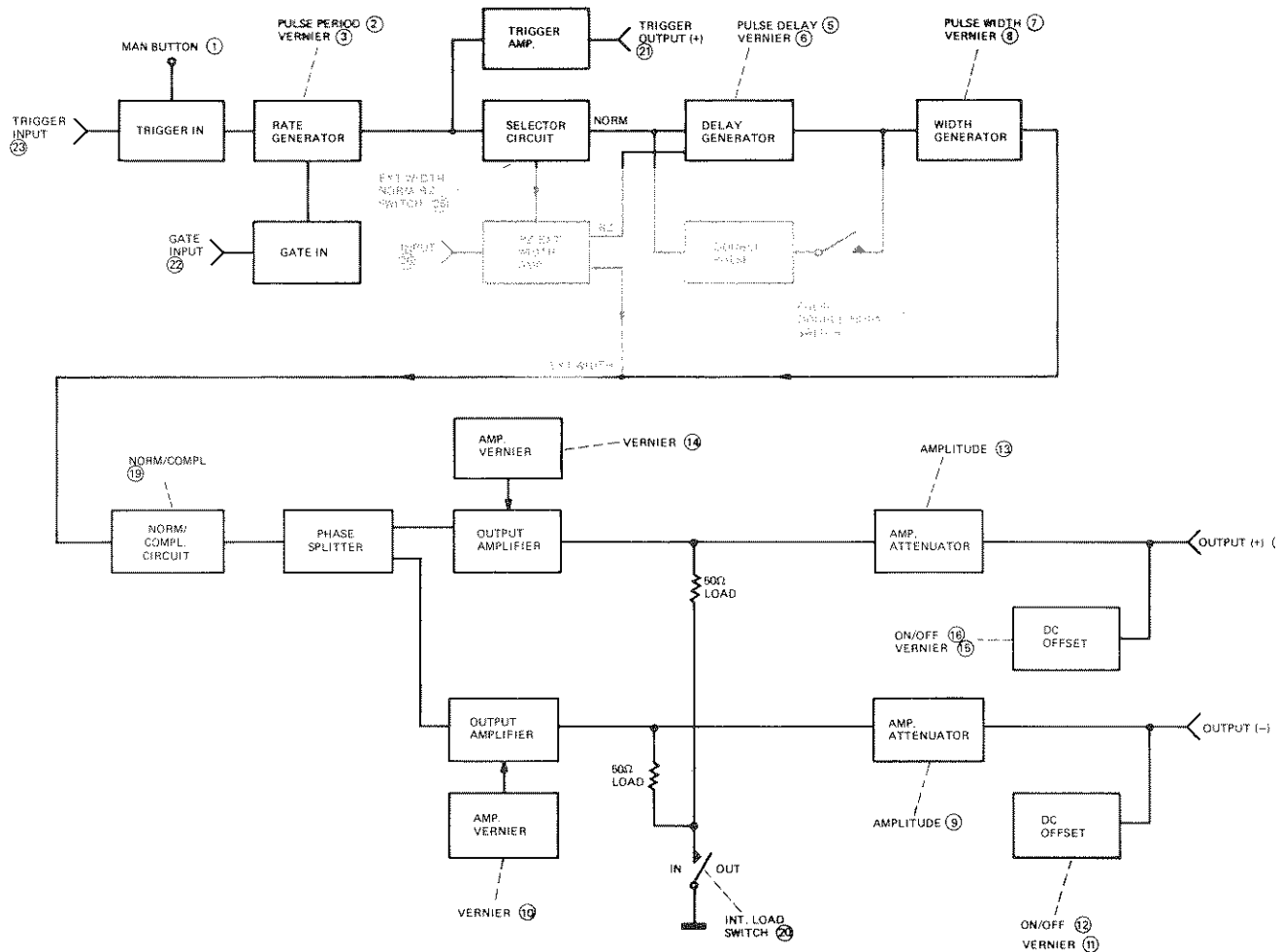

Figure 3-13. Normal gate mode – block diagram

3-37 The output pulses should appear at the TRIGGER OUTPUT (21) and OUTPUT (+) (17) connectors as shown in Figure 3-14.

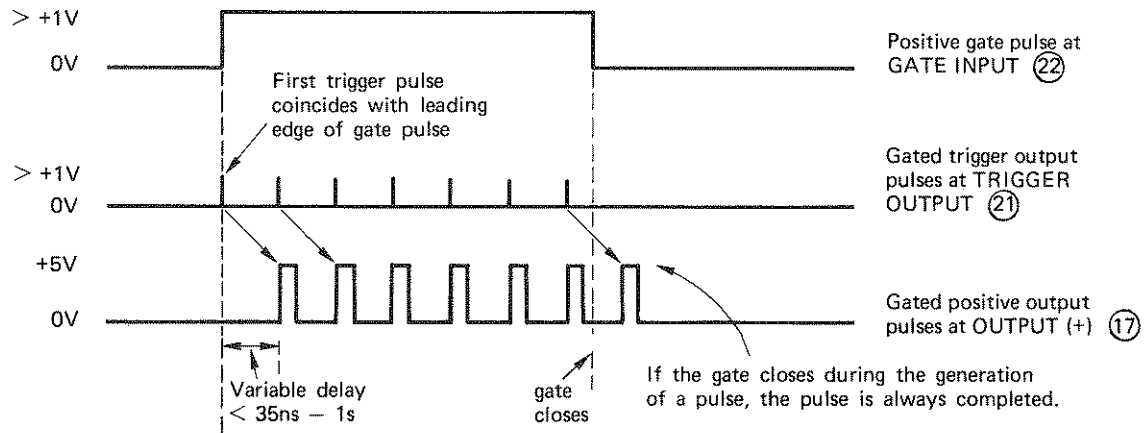

Figure 3-14. Output pulses in gate mode

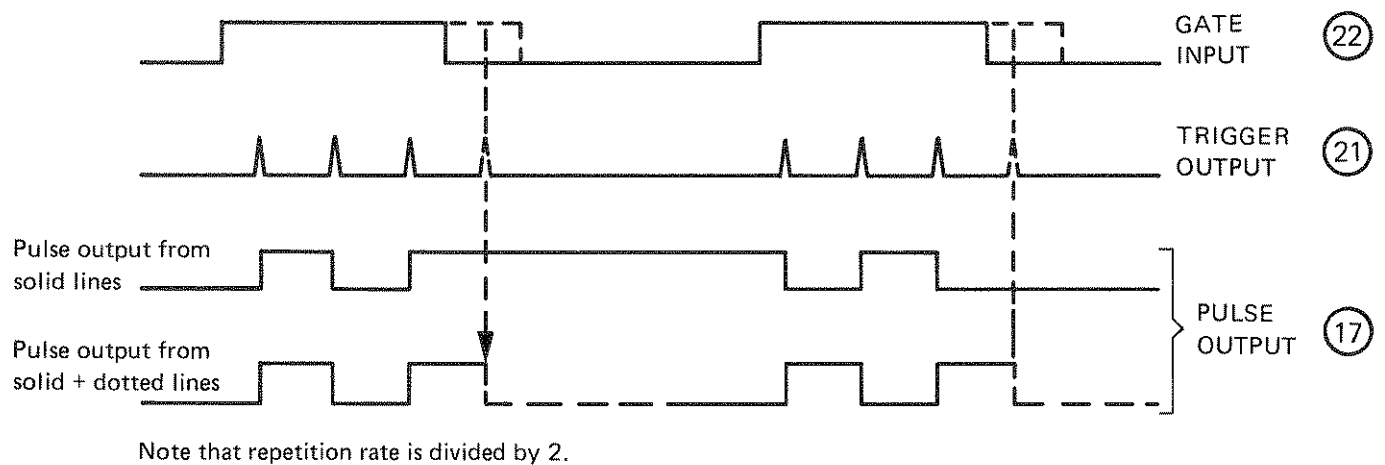

Figure 3-15. Gated output in square wave mode

3-38 RZ MODE

3-39 In RZ mode external pulses, applied to the INPUT connector (26) on the 8013B rear panel, trigger the delay generator directly (see figure 3-16) and the shape of the output pulses is determined by the out-

put amplifiers. The output pulses cannot be gated and are independent of the pulses at the TRIGGER OUTPUT connector (21).

3-40 The circuits and controls involved in RZ mode are shown in figure 3-16.

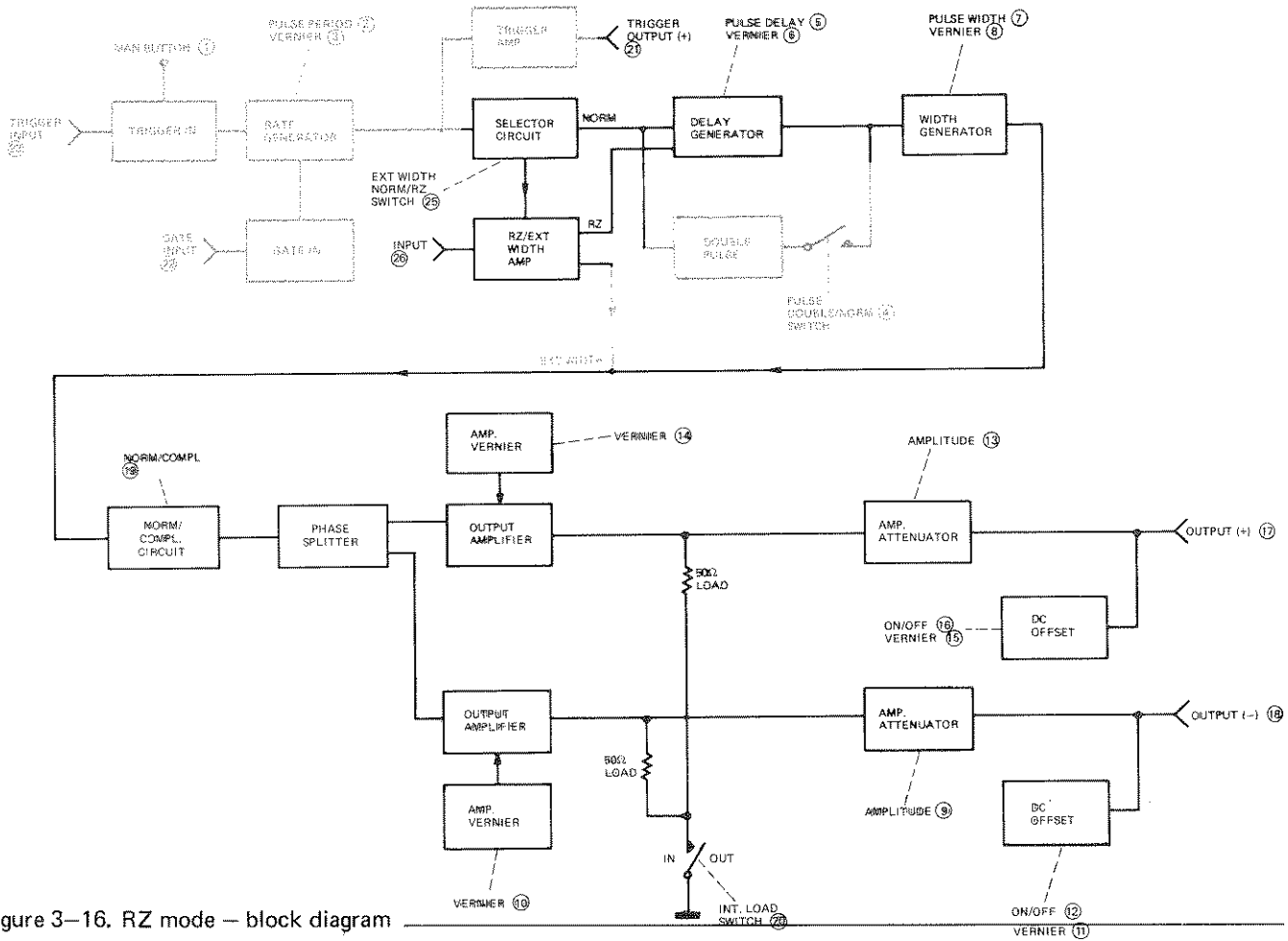

Figure 3-16. RZ mode – block diagram

3-41 The RZ input signal must be $> +1V$ to a maximum of $\pm 5V$ in amplitude and must be at least 7ns wide.

3-42 The procedure for obtaining an output in RZ mode is as follows:

a. Connect the external signal to the INPUT connector (26) on the rear panel of the 8013B.

b. Set the Mode Selector switch (25) to RZ

c. Set the pulse delay, width, amplitude, offset and output format as required.

3-43 The output pulses should appear at the OUTPUT (+) connector (17) as shown in Figure 3-17.

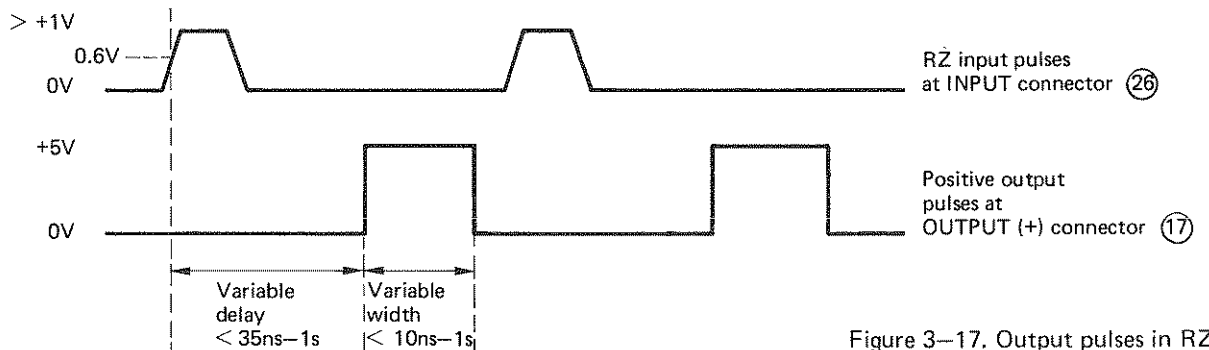

Figure 3-17. Output pulses in RZ mode

3-44 DOUBLE PULSE Mode

3-45 In this mode, the 8013B delivers two output pulses for each trigger pulse. One pulse is in phase with the TRIGGER OUTPUT (21); the other pulse is delayed by the time set on the PULSE DELAY controls (5) and (6).

3-46 Double pulse output can be selected in any of the preceding operating modes except square wave. Double pulse output is produced as follows:

a. Set the PULSE DOUBLE/NORM switch (4) to DOUBLE.

b. The remaining pulse parameters and output format can be set as required.

3-47 The circuits and controls involved in double pulse mode are shown in Figure 3-18.

3-48 The trigger and output pulses should appear at the TRIGGER OUTPUT (21) and OUTPUT (+) (17) connectors as shown in Figure 3-19.

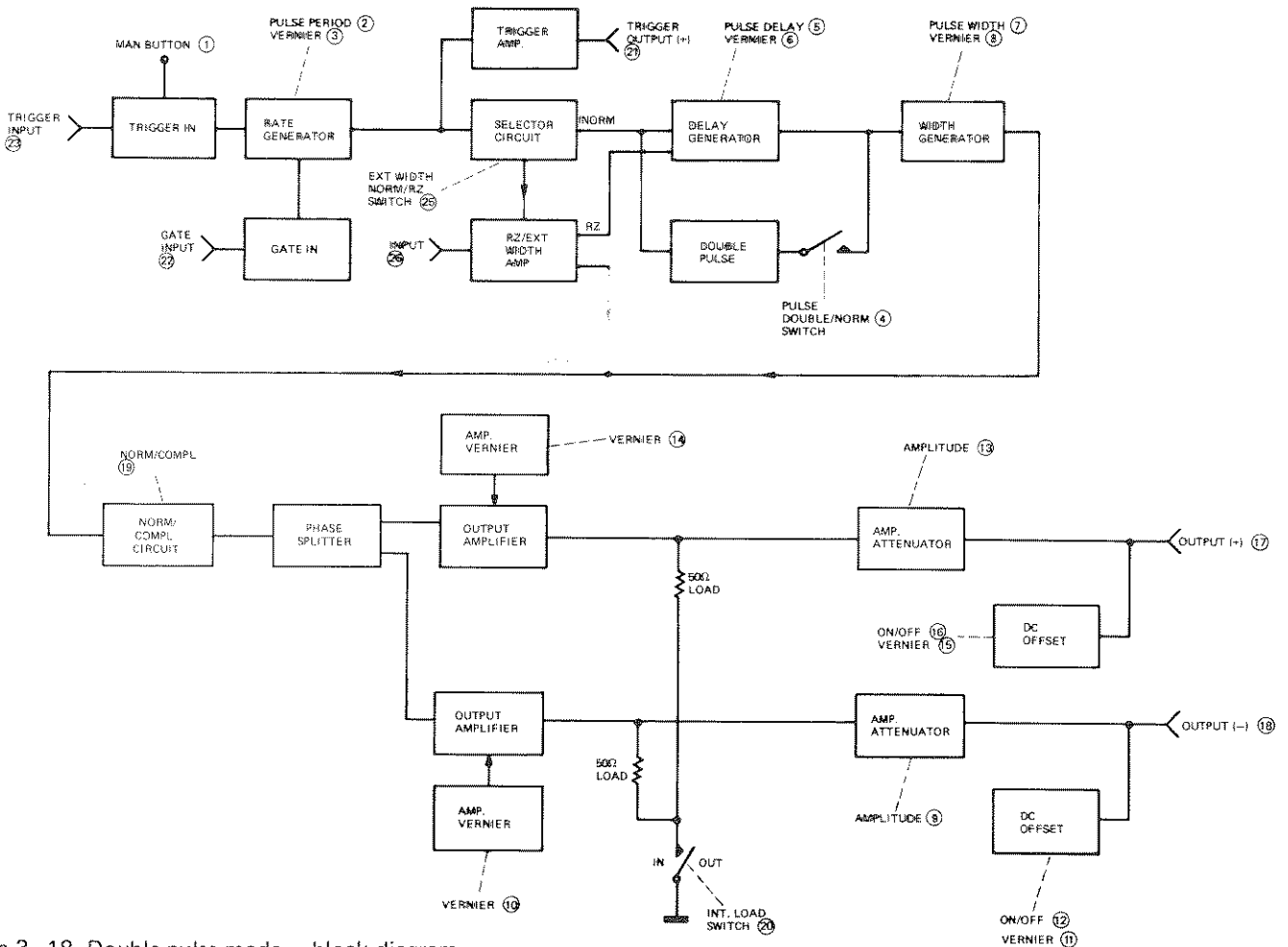

Figure 3-18. Double pulse mode – block diagram

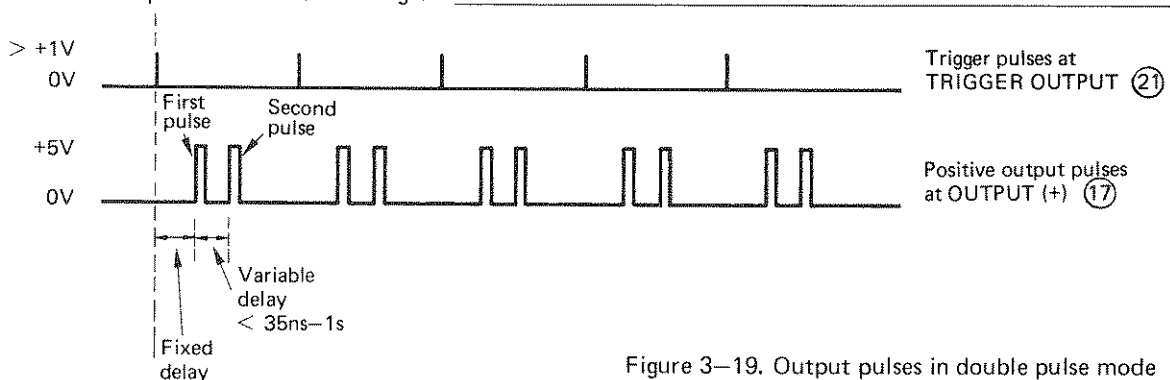

Figure 3-19. Output pulses in double pulse mode

3-49 EXTERNAL WIDTH MODE

3-50 In this mode, external pulses, applied to the INPUT connector (26) on the rear panel, are routed directly to the output amplifiers which are caused to change state at the threshold level of the input signal. Thus the pulse output is a shaped version of the input. It is also independent of the TRIGGER OUTPUT (21).

The external width input signal must be $> +1V$ to a maximum of $\pm 5V$ in amplitude and must be at least 7ns wide.

3-51 The circuits and controls involved in external width mode are shown in Figure 3-20.

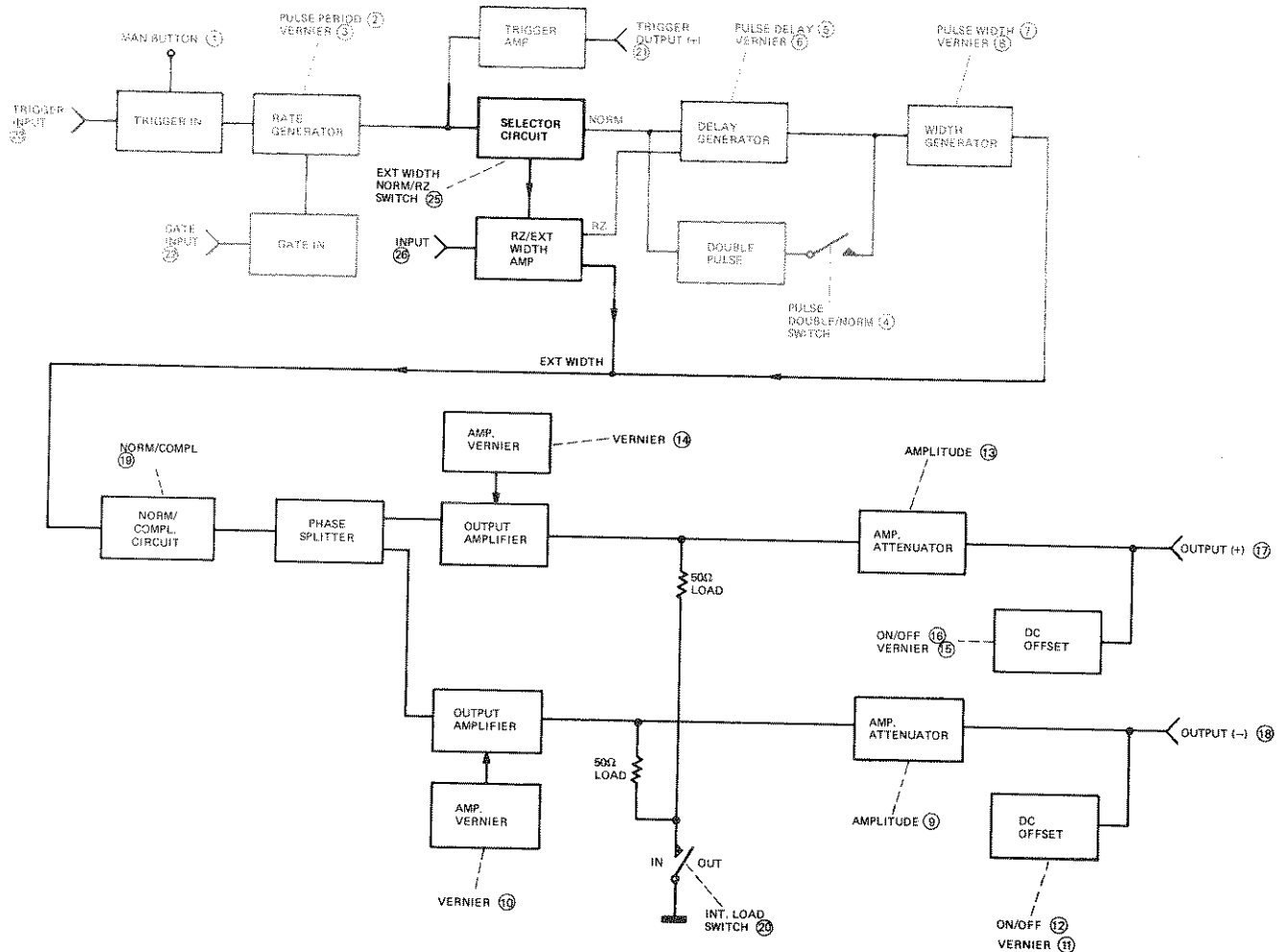

Figure 3-20. External Width mode — block diagram

3-52 The procedure for obtaining an output in external width mode is as follows:

- Connect the external signal to the INPUT connector (26) on the rear panel of the 8013B.
- Set the Mode Selector switch (25) to EXT WIDTH.

c. Set the pulse amplitude and output format as required.

3-53 The output pulses should appear at the OUTPUT (+) connector (17) as shown in Figure 3-21.

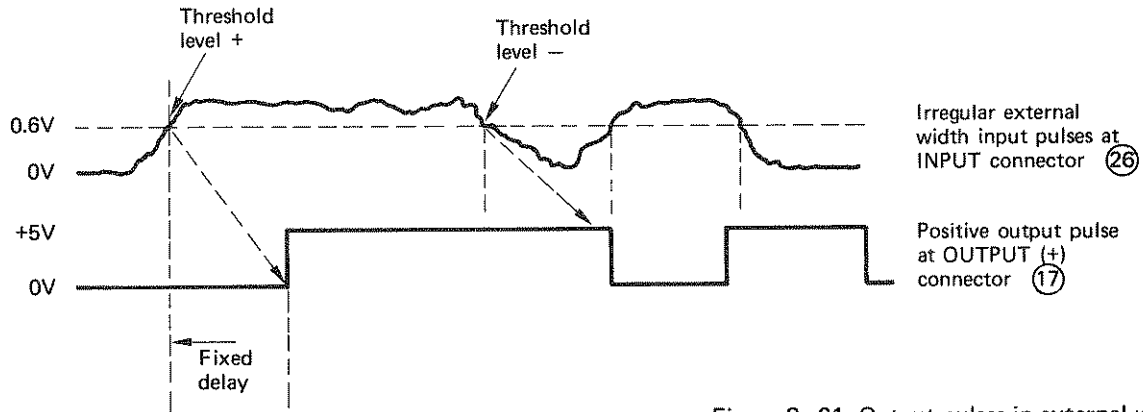

Figure 3-21. Output pulses in external width mode

3-54 ADDITIONAL FACILITIES IN RZ AND EXT WIDTH MODES

3-55 When operating in RZ or EXT WIDTH modes, the internal rate generator is available as an independent clock generator which provides an output at the TRIGGER OUTPUT connector (21). This output

can be triggered internally, externally or manually and can also be gated as in the normal operating mode. If this facility is not required, it can be switched off by setting the PULSE PERIOD control (2) to EXT and disconnecting the TRIGGER INPUT (23). The circuits and controls involved in this facility are shown in Figure 3-22.

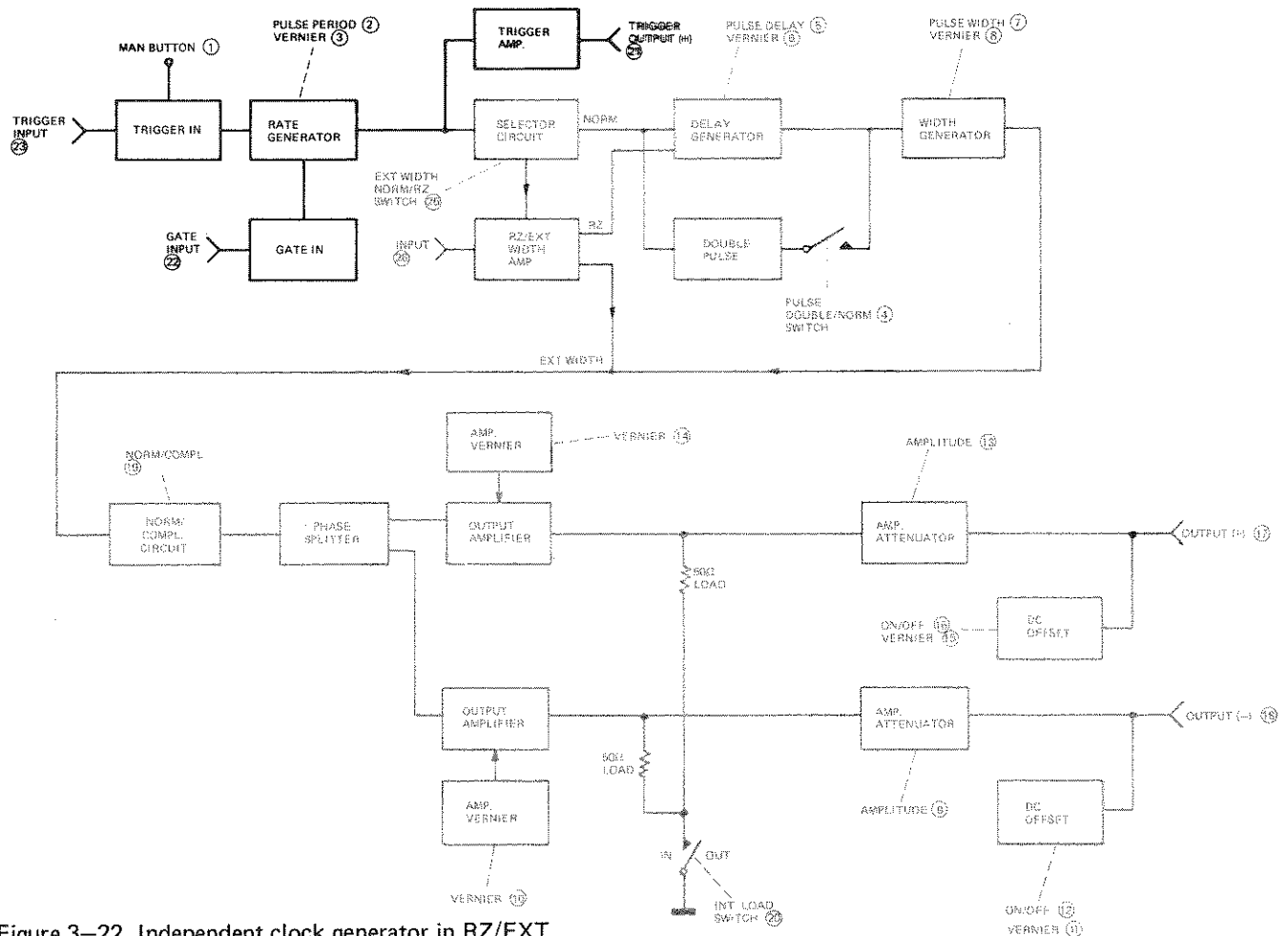

Figure 3-22. Independent clock generator in RZ/EXT WIDTH modes — block diagram



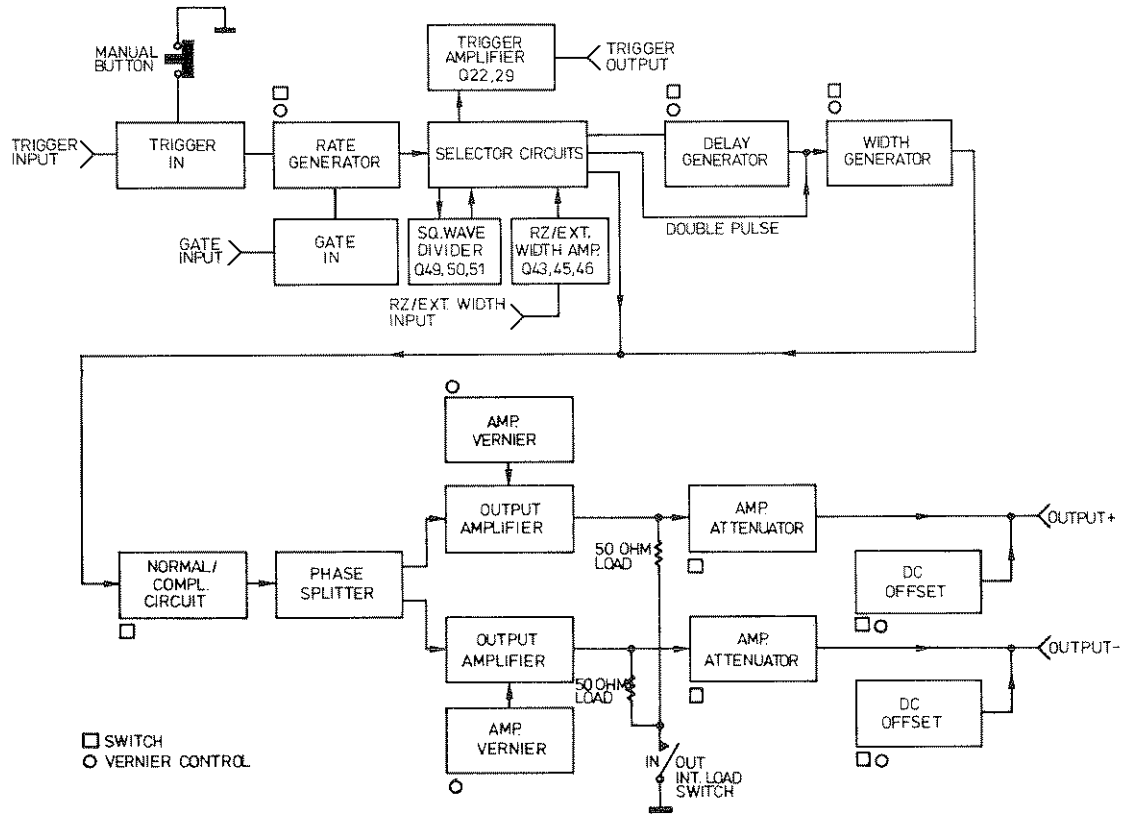

Figure 4-1. 8013B Pulse Generator – Block Diagram

4-1 INTRODUCTION

4-2 A basic block diagram of the 8013B is shown in Figure 4-1 and this diagram should be referred to when reading the following description. The pulse repetition rate is generated either internally by the rate generator, manually using a push-button, or externally by an applied signal. The pulses produced can be gated synchronously by applying an external gating signal to the gate input. The output of the rate generator is fed to the selector circuits and to the trigger amplifier to produce a trigger output.

4-3 The 8013B can be used in one of three modes of operation; Normal mode, RZ mode and External Width mode. In Normal mode the pulses are generated as described above; In RZ mode external signals, applied directly to the delay generator, determine the repetition rate of the output pulses; In External Width mode external signals, applied to the Normal/Complement circuit, determine the width and repetition rate of the output pulses. The mode switching is accomplished by the selector circuits.

4-4 The output of the selector circuits, in Normal and RZ modes is applied to the delay generator which delays the pulses by the amount set on the delay controls.

4-5 In double pulse mode two pulses are produced for each trigger pulse; the normal delayed pulse plus an extra pulse that by-passes the delay generator and is thus not delayed.

4-6 The pulse spikes from the delay generator are applied to the width generator where pulses of defined width are created.

4-7 The output of the width generator or, in External Width mode, the external input signal is applied to a pulse shaper where two complementary signals are generated. These two signals are then applied to the normal/complement circuit.

4-8 The signals are then applied to two variable gain output amplifiers and attenuators. Finally the variable DC offset is added.

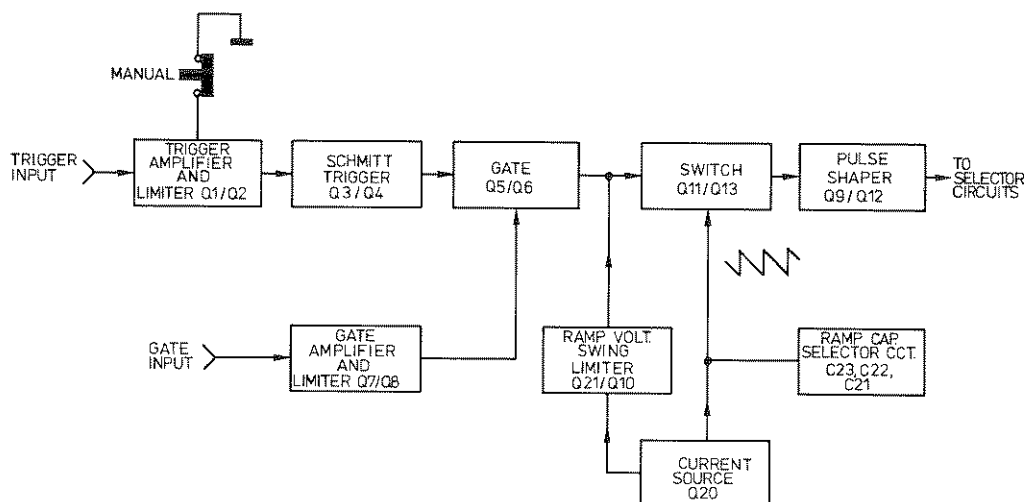

Figure 4-2. Repetition rate generator — block diagram

4-9 REPETITION RATE GENERATOR

4-10 A block diagram of the repetition rate generator is given in figure 4-2 and a full schematic in diagram 1. These diagrams should be referred to when reading the following description.

- 4-11 The pulse repetition rate is determined;
- by the internal rate generator
 - externally using an applied signal
 - manually using a pushbutton.

4-12 Internal Rate Generator

4-13 When the internal rate generator is used, one of four period ranges is selected using the period range switch. In the three slower ranges, ramp capacitors (C23, C22, C21) are selected to provide the required repetition rate; transistors Q17, Q18 and Q19 switch these capacitors in or out. In the fastest range, no ramp capacitor is switched in; the time is determined by preset capacitor C24. In operation the selected capacitor discharges through constant current sink Q20 controlled by the pulse period vernier R1 and the value of the capacitor.

As the voltage at Q20 collector approaches zero, CR17 becomes forward biased causing Q11 and Q13 to conduct and rapidly recharge the capacitor. The pulse period vernier controls Q21 and Q10 which act as a voltage swing limiter and determine the upper voltage limit to which the ramp capacitor can recharge. When the capacitor has recharged to this limit, Q13 and Q11 cut off thus allowing the discharge cycle to resume. The output from Q11 is applied, via the differentiator network Q28/L3/R35, to the delay generator and the trigger output amplifier.

4-14 External Trigger Operation

4-15 In external trigger mode the rate generator is used as a pulse shaper. Trigger pulses are applied to the differential amplifier Q1/Q2 which in turn switches the Schmitt trigger formed by Q3/Q4. The negative output spikes from the collector of Q4 turn Q5 on and Q13 base rises so that Q13 and Q11 turn on to produce an output pulse.

4-16 Manual Operation

4-17 When the Manual pushbutton is pressed, a negative spike is produced at the collector of Q4 which enables the current switch Q11/Q13. One pulse is produced from Q11 each time the Manual pushbutton is pressed.

4-18 GATING

4-19 Gate signals are applied to the gate amplifier Q8/Q7. Q8, normally 'off' is turned on by the 0V level (off time) of the gate input pulse. Thus Q6 is turned on, the current through Q6 lowers the base voltage of Q13 and so disables the rate generator. When the level of the gate input pulse reaches +1.8V (on time) Q8 turns on and enables the pulse source. Thus output pulses will be produced from the rate generator only during the gate input pulse 'on' time.

4-20 SELECTOR CIRCUITS

4-21 A block diagram of the selector circuits is given in figure 4-3 and is repeated for each mode of operation showing the signal paths used. Figure 4-1, 4-3 and the schematic diagram 2 should be referred to when reading the following description.

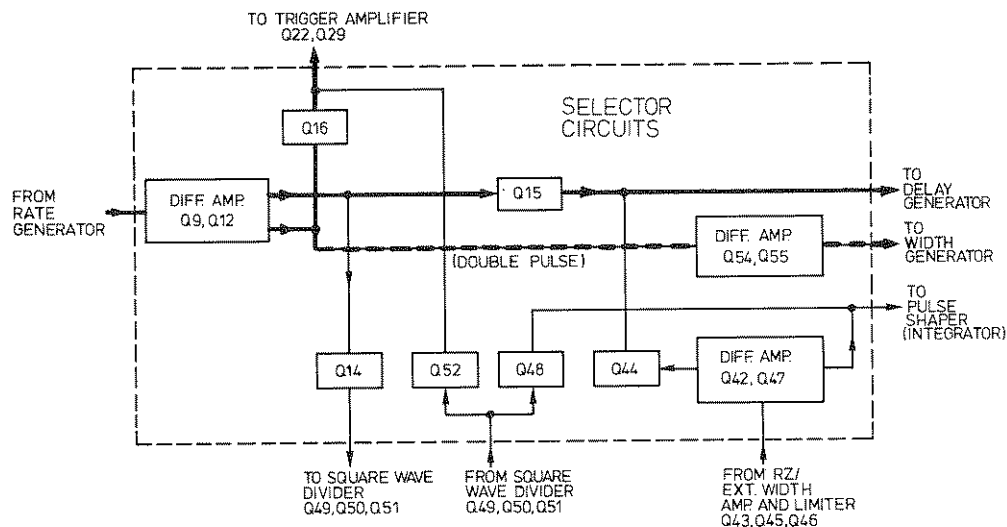

Figure 4-3a. Normal mode (including external trigger and rate mode).

4-22 In Normal mode, the rate generator output is applied to the delay generator via Q15 and to the trigger amplifier via Q16. If double pulse mode is selected, the pulse is also applied to the width generator via differential amplifier Q54/Q55 (see schematic 3).

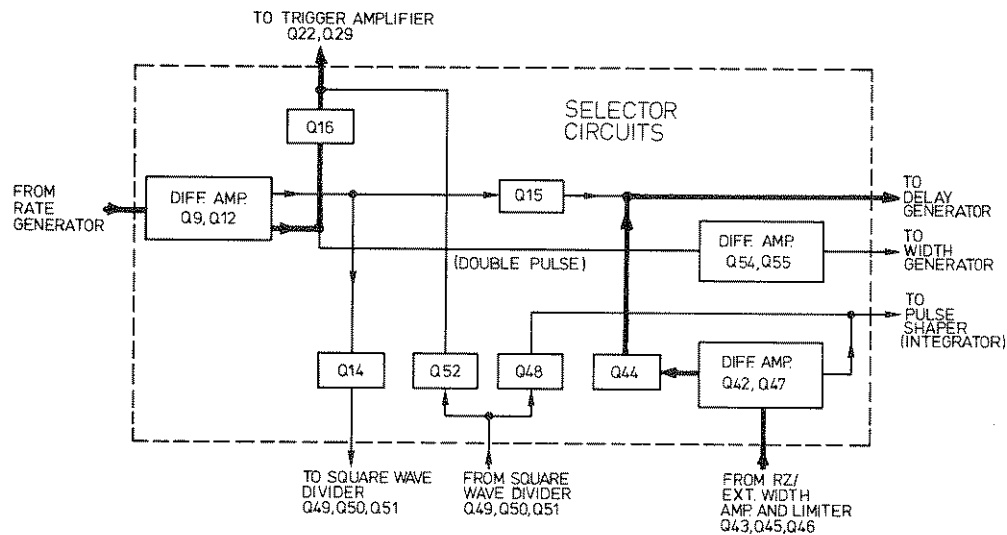

Figure 4-3b. RZ mode

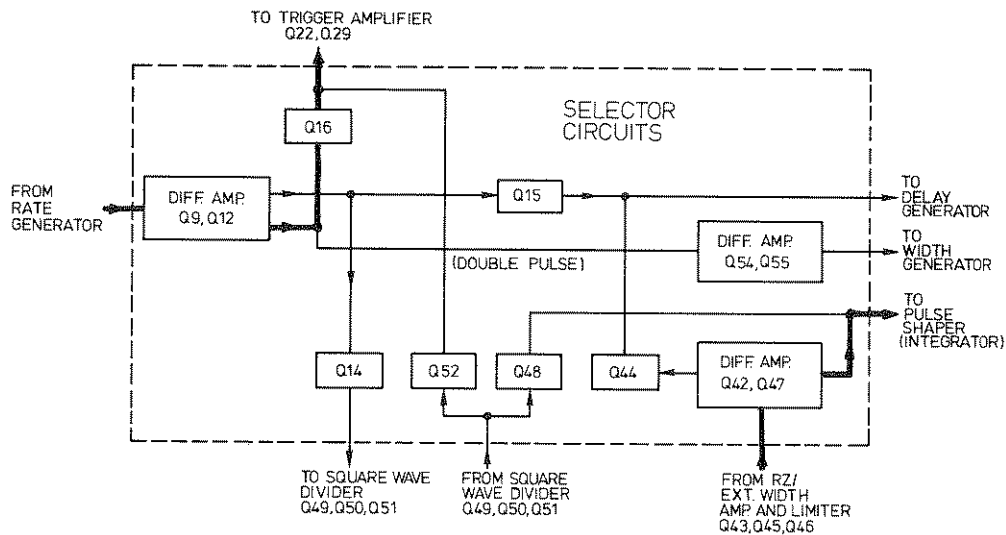

Figure 4-3c. Ext. Width mode

4-23 In RZ mode the rate generator output is only used to generate trigger pulses, via Q16. The RZ input is applied, via Q43, Q46, Q45 to the differential amplifier Q42/Q47 and gate Q44, to the delay generator.

4-24 In Ext. Width mode the rate generator output is only used to generate trigger pulses, via Q16. The Ext. Width input is applied, via Q43, Q46, Q45 to the differential amplifier Q42/Q47 to pulse shaper 3 and the integrator.

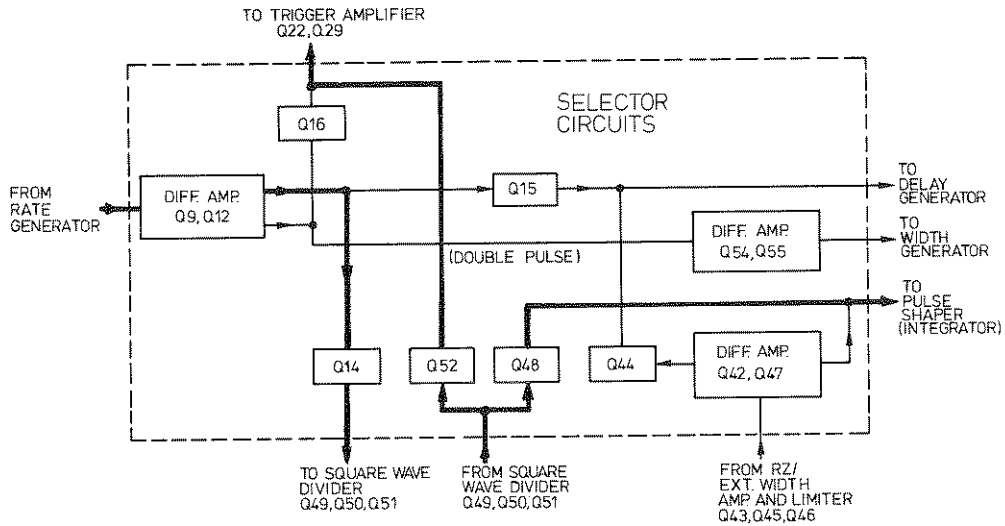

Figure 4-3d. Square wave mode

4-25 In Square wave mode the output of the rate generator is applied, via Q14, to the square wave divider. The output of the divider is applied to the trigger amplifier, via Q52, and pulse shaper 3 and the integrator, via Q48.

4-28 The purpose of the delay generator is to delay the pulse source, whether from the internal rate generator, external trigger or from the RZ input, within the range of 35ns to 1s, with respect to the trigger output.

4-26 DELAY GENERATOR

4-27 A block diagram of the delay generator is given in figure 4-4 and a full schematic in diagram 3. These diagrams should be referred to when reading the following description.

4-29 The current source (Q23), the monostable (Q30/Q31) and the recharge circuit (Q26) are controlled by the width switch so that the delay circuit is inhibited in square wave and external width modes.

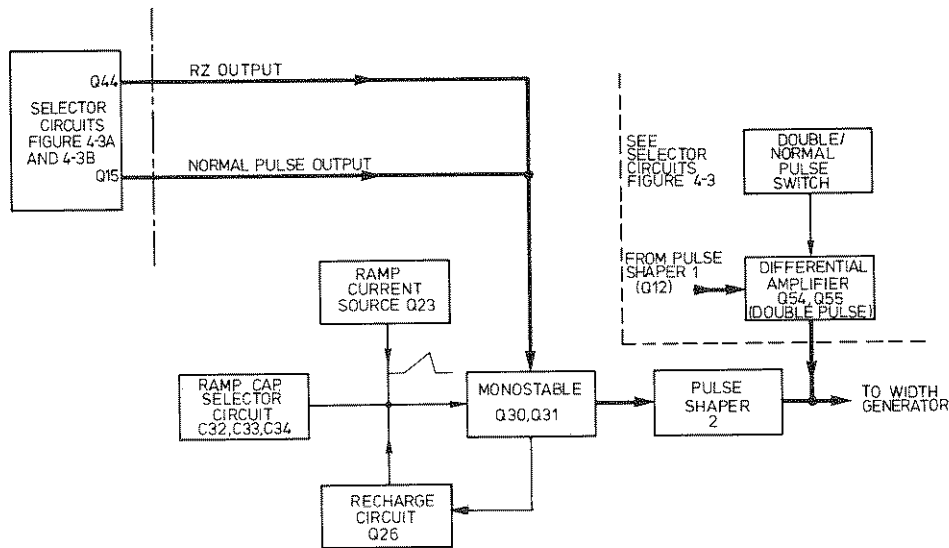

Figure 4-4. Delay generator - block diagram

4-30 Under no-signal conditions, Q31 is off, Q30 is on and Q26 is acting as a sink for the ramp current. Thus the ramp current source (Q23) cannot charge the ramp capacitors. A positive pulse input signal turns Q31 on and Q30 off, Q26 follows Q30 collector and thus is non-conducting. The selected ramp capacitor is charged by the current source Q23 until a level is reached when Q30 turns on again, which

turns Q31 off. Q26 now conducts again and rapidly discharges the selected ramp capacitor. The output from the monostable is a negative spike, coincident with the pulse input, followed by a positive spike which occurs some time later and is used to drive pulse shaper 2. The time between the pairs of spikes is the time taken for the ramp waveform to reach the threshold level of the monostable (Q30/Q31), i.e. the delay time.

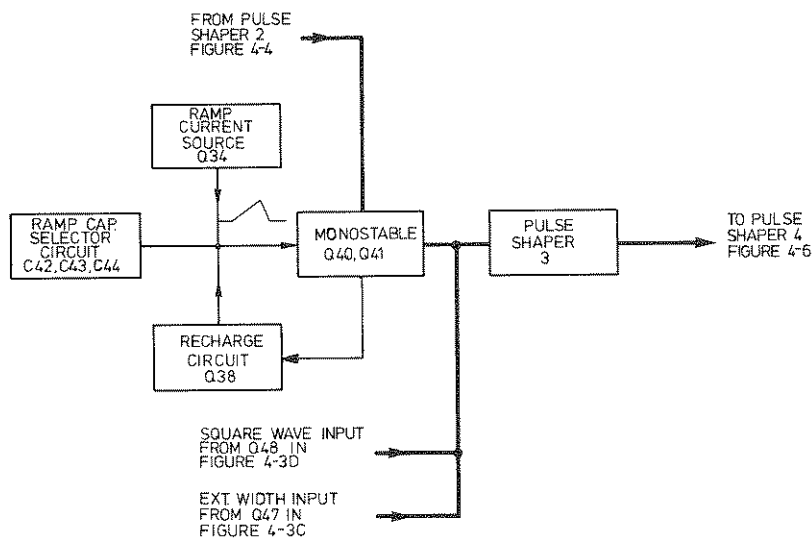

Figure 4-5. Width generator — block diagram

4-31 WIDTH GENERATOR

4-32 A block diagram of the width generator is given in figure 4-5 and a full schematic in diagram 4. These diagrams should be referred to when reading the following description.

4-33 The function of the width generator is to create a pulse of defined width for each positive pulse spike received from the delay generator. The current source (Q34) and the monostable (Q40/Q41) are controlled by the width switch so that the width circuit is inhibited in square wave and external width modes.

4-34 The width generator circuit is identical to the delay generator circuit except for the differentiator on the output (L11); see para. 4-30. The output pulse is applied to pulse shaper 3.

4-35 If square wave or external width modes are being used, the output signals from the selector circuits in figures 4-3c and 4-3d are applied directly to pulse shaper 3 and both the delay and width generators are disabled.

4-36 The two complementary outputs from pulse shaper 3 are then applied to the Normal/Complement circuit.

4-37 OUTPUT AMPLIFIERS

4-38 A block diagram of the output amplifiers is given in figure 4-6 and a full schematic in diagram 4. These diagrams should be referred to when reading the following description.

4-39 The Normal/Complement circuit consists of transistors Q29 to Q32 which are controlled in pairs

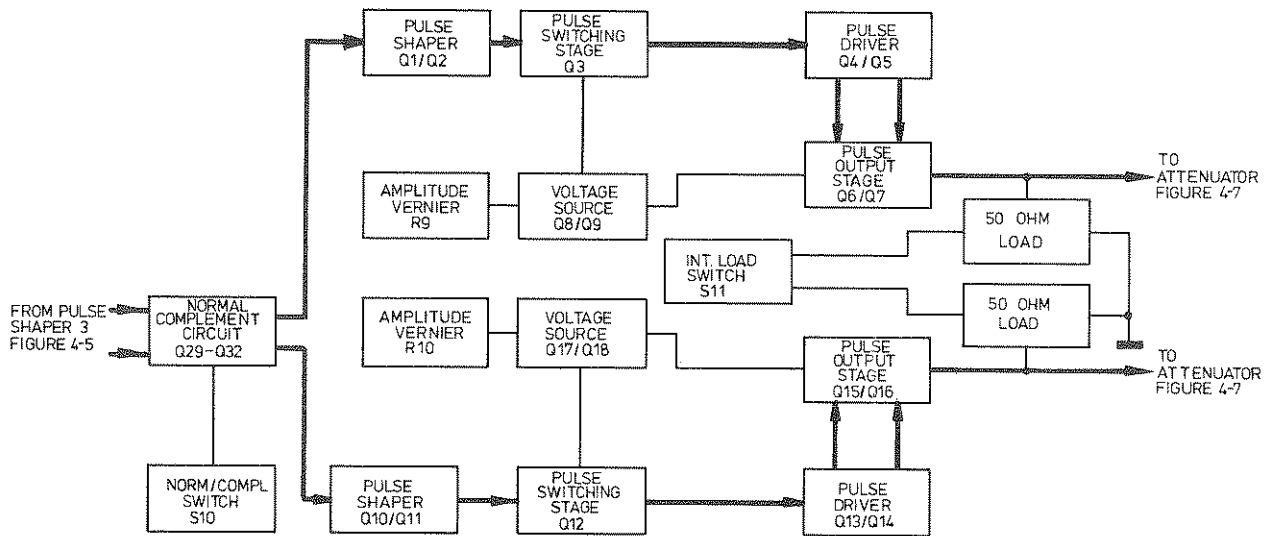

Figure 4-6. Output amplifiers — block diagram

(Q29/Q30 and Q31/Q32) by the NORM/COMPL switch (S10). Either one pair or the other is enabled to transpose the two pulse inputs.

4-40 The two complementary differentiated outputs are applied to pulse shaper Q1/Q2 for the positive channel and pulse shaper Q10/Q11 for the negative channel. The output of Q2 drives the positive output amplifier (Q4 to Q7) via a switching transistor Q3; the output of Q11 drives the negative output amplifier (Q13 to Q16) via a switching transistor Q12.

4-41 Amplitude verniers R9 and R10 determine the potential across the respective voltage sources (Q8/Q9 for the positive channel and Q17/Q18 for the negative channel). This determines the pulse amplitude swing for each channel.

4-42 When the internal load switch S11 is set to the 'in' position, relays K1 and K2 are energized and connect the 50 ohm loads to their respective outputs.

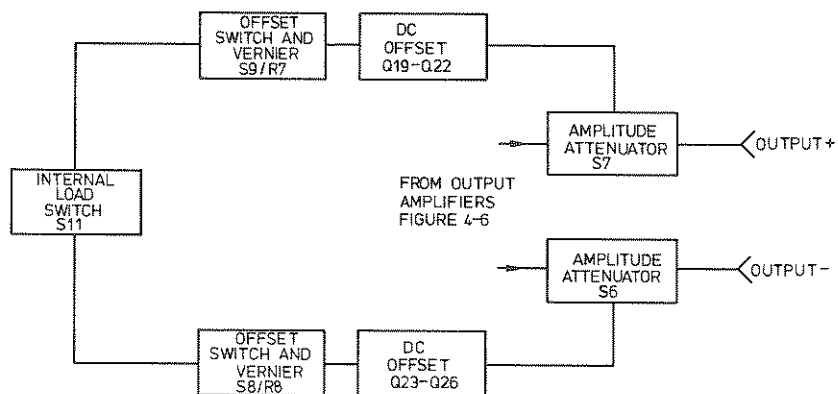

Figure 4-7. Offsets and attenuators — block diagram

4-43 OFFSETS AND ATTENUATORS

4-44 A block diagram of the offsets and attenuators is given in figure 4-7 and a full schematic in diagram 6. These diagrams should be referred to when reading the following description.

4-45 The pulses from the output amplifiers are applied to the two attenuator networks which can reduce the amplitude of each channel from 10V to 0.4V with the 50 ohm load switched out or from 5V to 0.2V with the 50 ohm load switched in.

4-46 The dc offset circuits comprise Q19 to Q22 for the positive channel and Q23 to Q26 for the negative channel. Both circuits operate in the same way and thus only the positive channel is described. Note that the offset is not available when the internal load is switched out.

4-47 When the offset switch (S9) is set to 'off', the vernier (R7) is shorted out. Thus Q19/Q20 and Q21/Q22 are switched off and deliver no current. When the offset switch is set to 'on', clockwise rotation of the vernier increases the output from Q20 and decreases the output from Q22. The output of the amplifier will then be positive. Counterclockwise rotation of the vernier causes the reverse to happen and the amplifier output to become negative.

4-48 POWER SUPPLIES

4-49 The +17V and -17V power supplies are identical series regulated types using IC regulators (U1 and U2) and series pass transistors (Q27 and Q28). Resistors R100 and R104 act as current sensing resistors to enable the regulators to limit the current output



5-1 GENERAL

5-2 This section contains information on the removal of covers and assemblies, performance verification and recalibration (internal checks and adjustments) procedures.

5-3 Before attempting removal of covers, assemblies or components, disconnect the instrument from the ac line supply. It is advisable also to leave the instrument for a few minutes after disconnecting from the line, to enable capacitors to discharge.

5-4 REMOVAL OF COVERS

5-5 To gain access to all test points and assemblies remove the four screws from each of the two covers and slide the covers off.

5-6 REMOVAL OF ASSEMBLIES

5-7 Reference should be made to the Assembly Location diagram (6-1) before attempting to remove assemblies. Table 6-2 gives the colour code used to identify the internal wiring, e.g. wire 93 is white with an orange stripe.

5-8 Timing board – assembly 5

5-9 Disconnect coaxial cable W2 and wires 93 and 94 from board A5. Remove the three long securing screws and spacers and ease the board out of its connector on board A7.

5-10 Output board – assembly 6

5-11 Disconnect wires 93 and 94 and unsolder coaxial cables W3 and W4 from board A6.

5-12 Remove the four screws securing the rear panel to the frame. Withdraw the rear panel and board A6 through the rear of the frame as far as the power supply leads will permit.

5-13 Remove the three screws securing board A6 to the rear panel. Unsolder the two wires number 923 and the two wires number 937 from board A6. Carefully withdrawn board A6 from the frame.

5-14 When board A6 is being refitted, thermal compound (HP part no. 6040-0265) must be applied to the output amplifier heat sink where it bolts on to the rear panel. This is necessary to improve thermal conductivity between the two surfaces.

5-15 Mother board – assembly 7

5-16 Remove boards A5 and A6 as detailed in paragraphs 5-8 to 5-13.

5-17 Unsolder coaxial cables W5 and W6 connecting the output jacks to board A7 at the board A7 end.

5-18 Unsolder the power supply wires (W7) from the line on/off switch (S12).

5-19 Disconnect the five wires 91, 92, 93, 90 and 0 from the top rear of board A7. Disconnect wire 7 from the rear centre of board A7.

5-20 Disconnect the three wires 3, 4 and 5 from the bottom rear of board A7.

5-21 Disconnect the wires from all vernier controls, i.e. R1, R2, R3, R7, R8, R9 and R10 at the board A7 end.

5-22 Remove the six screws securing board A7 to the front panel and carefully remove the board from the frame.

5-23 EQUIPMENT REQUIRED

5-24 A complete list of required test equipment and accessories is given in table 5-1. Test equipment equivalent to that recommended may be substituted, provided it meets the specifications listed in table 5-1. For best results, use recently calibrated test equipment.

5-25 PERFORMANCE TESTS

5-26 The performance tests in tables 5-2 to 5-20 give the procedures for verifying that the instrument is working to the specifications. Rigid observance of the sequence in which the tests appear is unnecessary.

5-27 INTERNAL CHECKS AND ADJUSTMENTS

5-28 The internal checks and adjustments in tables 5-21 to 5-25 give the procedures for adjusting a ser-

viceable instrument to bring it within specification. The checks should be performed in the order in which they appear.

5-29 SERVICE PRODUCT SAFETY CHECK

5-30 This check (table 5-26) should be performed following the internal checks and adjustments to verify the instrument safety.

Table 5-1. Test Equipment and Accessories

INSTRUMENT	BRIEF SPECIFICATION	RECOMMENDED MODEL
Counter	Frequency range 0 – 50 MHz with Prescaler plug-in	HP 5245L HP 5252A
Oscilloscope	Dual-channel 50 MHz bandwidth 20mV/div sensitivity, sweep speeds 100ns/div to 1s/div. with sweep delay	HP 180C with plug-ins 1801A, 1821A
Digital Voltmeter	100V range. Accuracy $\pm (0.03\% \text{ reading} + 0.01\% \text{ range})$.	HP 3470 system comprising 34740A display and 34702A Multimeter.
Sampling Oscilloscope	Dual-channel, 1 GHz bandwidth 2mV/div. sensitivity, sweep speeds 100ps/div to 50 μ s/div.	HP 180C with plug-in 1810A
Test Oscillator	Frequency range 10 Hz to 10 MHz	HP 651B
Test Oscillator	Frequency range 10 MHz to 500 MHz	HP 3200B
Pulse Generator	Rep. rate at least 1 MHz variable width (1 μ s to 100ms), amplitude 0V to ± 5 V.	HP 8011A

ACCESSORIES

50 ohm cable assembly, 23cm long, with male BNC connectors	HP 10502A
50 ohm cable assembly, 122cm long, with male BNC connectors (4 required)	HP 10503A
Test leads for DVM – dual banana plug to probe and clip	HP 11003A
Connector, BNC male to type N female (2 required)	HP 1250-0077
Connector, type N male to BNC male (2 required)	HP 1250-0780
Tee Connector, BNC	HP 1250-0781
50 ohm Feed-through termination	HP 10100C
Pulse Adder	HP 15104A
20dB Attenuator, 50 ohm (2 required)	HP 8491A

Table 5-2. Performance Test: Pulse Period

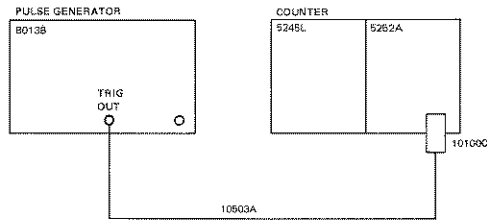

INITIAL CONTROL SETTINGS

PULSE PERIOD	2	20n-1μ
VERNIER	3	CCW
PULSE DOUBLE/NORM	4	NORM
PULSE DELAY	5	35n-1μ
VERNIER	6	CCW
PULSE WIDTH	7	10n-1μ
VERNIER	8	CCW
AMPLITUDE	9	5.0-2.0
VERNIER	10	CW
OFFSET vernier	11	-
OFFSET switch	12	OFF
AMPLITUDE	13	5.0-2.0
VERNIER	14	CW
OFFSET vernier	15	-
OFFSET switch	16	OFF
NORM/COMPL	19	NORM
INT LOAD	20	IN
EXT WIDTH/NORM/RZ	25	NORM

5245L:

FUNCTION	FREQUENCY
SENSITIVITY	1V
TIME BASE	adjust as necessary

STEP INSTRUCTIONS RESULTS

- 1 Check repetition rate for each set of control settings given in table:

PULSE PERIOD	VERNIER	PULSE WIDTH	VERNIER		
2	3	7	8		
20n-1μ	CCW	10n-1μ	CCW	< 20ns	> 50 MHz
20n-1μ	CW	1μ-.1m	CCW	> 1μs	< 1 MHz
1μ-.1m	CCW	1μ-.1m	CCW	< 1μs	> 1 MHz
1μ-.1m	CW	.1m-10m	CCW	> .1ms	< 10 KHz
.1m-10m	CCW	.1m-10m	CCW	> .1ms	> 10 KHz
.1m-10m	CW	10m-1	CCW	> 10ms	< 100 Hz
10m-1	CCW	10m-1	CCW	< 10ms	> 100 Hz
10m-1	CW	10m-1	Center	> 1s	< 1 Hz

For the last setting, set the 5245L FUNCTION switch to PERIOD AVERAGE 1 and measure the pulse period

Table 5-3. Performance Test: Pulse Delay

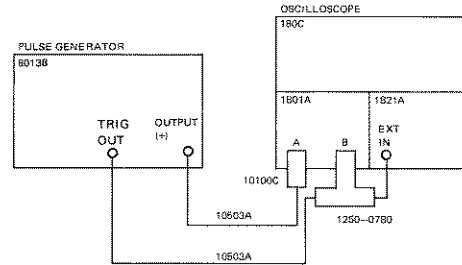

INITIAL CONTROL SETTINGS

PULSE PERIOD	2	1μ-.1m
VERNIER	3	CW
PULSE DOUBLE/NORM	4	NORM
PULSE DELAY	5	35n-1μ
VERNIER	6	CW
PULSE WIDTH	7	10n-1μ
VERNIER	8	Center
AMPLITUDE	9	5.0-2.0
VERNIER	10	CW
OFFSET vernier	11	-
OFFSET switch	12	OFF
AMPLITUDE	13	5.0-2.0
VERNIER	14	CW
OFFSET vernier	15	-
OFFSET switch	16	OFF
NORM/COMPL	19	NORM
INT LOAD	20	IN
EXT WIDTH /NORM /RZ	25	NORM

STEP INSTRUCTIONS

- 1 Check the pulse delay for both VERNIER 6 extremities of each range setting of the PULSE DELAY switch 5 as follows:

PULSE DELAY	VERNIER	PULSE PERIOD	PULSE WIDTH	
5	6	2	7	
35n-1μ	CCW	1μ-.1m	10n-1μ	< 35ns
35n-1μ	CW	1μ-.1m	10n-1μ	> 1μs
1μ-.1m	CW	.1m-10m	1μ-.1m	> 100 μs
1μ-.1m	CCW	1μ-.1m	1μ-.1m	< 1μs
.1m-10m	CW	.1m-10m	.1m-10m	> 10ms
.1m-10m	CCW	.1m-10m	.1m-10m	< 100μs
10m-1	CW	EXT+ (press MAN 1)	10m-1	> 1s
10m-1	CCW	10m-1	.1m-10m	< 10mS

Table 5-4. Performance Test: Pulse Width (greater than 1μs)

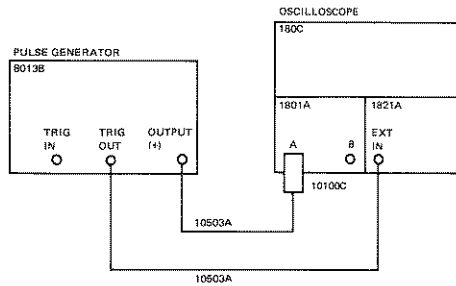

INITIAL CONTROL SETTINGS

PULSE PERIOD	2	1μ-.1m
VERNIER	3	CW
PULSE DOUBLE/NORM	4	NORM
PULSE DELAY	5	35n-1μ
VERNIER	6	CCW
PULSE WIDTH	7	10n-1μ
VERNIER	8	CW
AMPLITUDE	9	5.0-2.0
VERNIER	10	CW
OFFSET vernier	11	-
OFFSET switch	12	OFF
AMPLITUDE	13	5.0-2.0
VERNIER	14	CW
OFFSET vernier	15	-
OFFSET switch	16	OFF
NORM/COMPL	19	NORM
INT LOAD	20	IN
EXT WIDTH/NORM/RZ	25	NORM

STEP INSTRUCTIONS RESULTS

- 1 Check the pulse width for both VERNIER 8 extremities of each range setting of the PULSE WIDTH switch 7 as follows:

PULSE WIDTH	VERNIER	PULSE PERIOD	
7	8	2	
10n-1μ	CW	1μ-.1m	> 1μs
1μ-.1m	CW	.1m-10m	> .1ms
1μ-.1m	CCW	1μ-.1m	< 1μs
.1m-10m	CW	10m-1	> 10ms
.1m-10m	CCW	.1m-10m	< .1ms
10m-1	CW	EXT+(press MAN 1)	> 1s
10m-1	CCW	10m-1	> 10ms

Table 5-5. Performance Test: Minimum Pulse Width

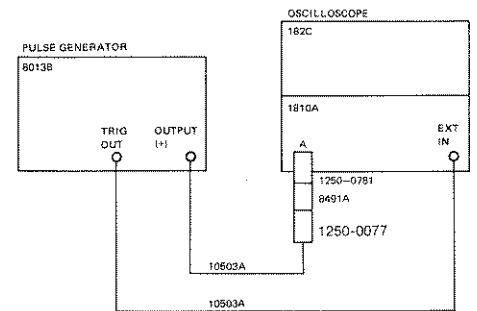

INITIAL CONTROL SETTINGS

PULSE PERIOD	2	20ns-1μ
VERNIER	3	Center
PULSE DOUBLE/NORM	4	NORM
PULSE DELAY	5	35n-1μ
VERNIER	6	CCW
PULSE WIDTH	7	10n-1μ
VERNIER	8	CCW
AMPLITUDE	9	5.0-2.0
VERNIER	10	CW
OFFSET vernier	11	-
OFFSET switch	12	OFF
AMPLITUDE	13	5.0-2.0
VERNIER	14	CW
OFFSET vernier	15	-
OFFSET switch	16	OFF
NORM/COMPL	19	NORM
INT LOAD	20	IN
EXT WIDTH/NORM/RZ	25	NORM

STEP INSTRUCTIONS RESULT

- 1 Measure the pulse width: < 10

.TS
ns

Table 5-6. Performance Test: Pulse Period Jitter

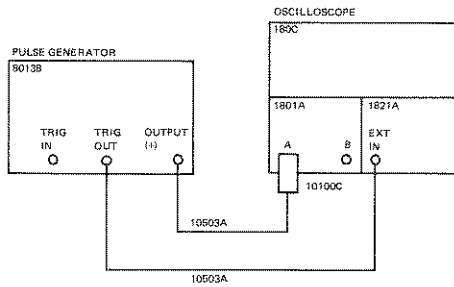

INITIAL CONTROL SETTINGS

PULSE PERIOD	2	1μ- .1m
VERNIER	3	see step 2
PULSE DOUBLE/NORM	4	NORM
PULSE DELAY	5	35n-1μ
VERNIER	6	CCW
PULSE WIDTH	7	1μ-.1m
VERNIER	8	CENTERED
AMPLITUDE	9	5.0-2.0
VERNIER	10	CW
OFFSET vernier	11	-
OFFSET switch	12	OFF
AMPLITUDE	13	5.0-2.0
VERNIER	14	CW
OFFSET vernier	15	-
OFFSET switch	16	OFF
NORM/COMPL	19	NORM
INT LOAD	20	IN
EXT WIDTH/NORM/RZ	25	NORM

STEP	INSTRUCTIONS	RESULTS
1	Set the 1821A controls as follows: Main Sweep 0.1ms/div Delayed Sweep 0.1μs/div Sweep Mode Norm. Delay Trigger Auto CM Delay 2.0	
2	Adjust pulse period VERNIER 3 to obtain 0.1ms pulse period on display.	
3	Adjust 1821A Delay (Div) vernier until intensified spot coincides with leading edge of second pulse on display.	
4	Switch to Delayed Sweep and center the pulse.	
5	Measure pulse period jitter:	<1 div.

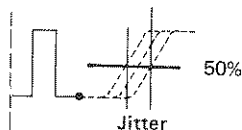
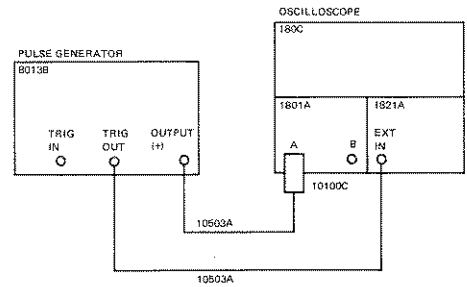

Table 5-7. Performance Test: Pulse Delay Jitter



INITIAL CONTROL SETTINGS

PULSE PERIOD	2	.1m-10m
VERNIER	3	CW
PULSE DOUBLE/NORM	4	NORM
PLSE DELAY	5	1μ-.1m
VERNIER	6	CW
PULSE WIDTH	7	1μ-.1m
VERNIER	8	CCW
AMPLITUDE	9	5.0-2.0
VERNIER	10	CW
OFSET vernier	11	-
OFFSET switch	12	OFF
AMPLITUDE	13	5.0-2.0
VENIER	14	CW
OFFSET vernier	15	-
OFFSET switch	16	OFF
NORM/COMPL	19	NORM
INT LOAD	20	IN
EXT WIDTH/NORM/RZ	25	NORM

STEP INSTRUCTIONS

1	Set the 1821A controls as follows: Main Sweep 0.1mS/div Delayed Sweep 0.1μS/div Sweep Mode Norm. Delayed Trigger Auto. CM Delay 10.0
2	Adjust pulse period VERNIER 3 to obtain 0.4mS pulse period on display.
3	Adjust pulse delay VERNIER 6 to obtain 0.1mS pulse delay.
4	Adjust 1821A Delay (Div) vernier until intensified spot coincides with leading edge of second pulse.
5	Switch to Delayed Sweep and center the leading edge.
6	Display should be:
7	Measure pulse delay jitter: <1 div.

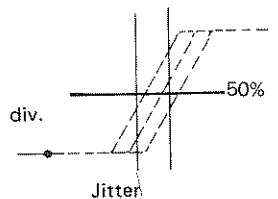
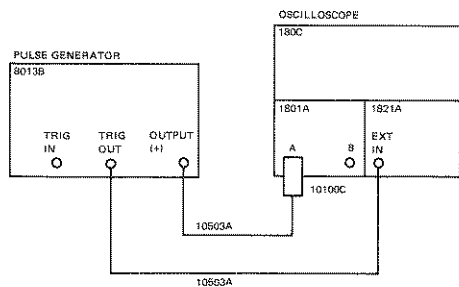

Table 5-8. Performance Test: Pulse Width Jitter



INITIAL CONTROL SETTINGS

PULSE PERIOD	2	.1m-10m
VERNIER	3	CW
PULSE DOUBLE/NORM	4	NORM
PULSE DELAY	5	35n-1μ
VERNIER	6	CCW
PULSE WIDTH	7	1μ-.1m
VERNIER	8	CW
AMPLITUDE	9	5.0-2.0
VERNIER	10	CW
OFFSET vernier	11	-
OFFSET switch	12	OFF
AMPLITUDE	13	5.0-2.0
VERNIER	14	CW
OFFSET vernier	15	-
OFFSET switch	16	OFF
NORM/COMPL	19	NORM
INT LOAD	20	IN
EXT WIDTH/NORM/RZ	25	NORM

JLTS

nal

try

15%
5%
5%
5%

a limits

STEP INSTRUCTIONS

- 1 Set 1821A controls as follows:

Main Sweep	0.1mS/div
Delayed Sweep	0.1uS/div
Sweep Mode	Norm.
Delayed Trigger	Auto.
CM Delay	10
- 2 Adjust pulse period VERNIER 3 to obtain 0.4ms pulse period on display.
- 3 Adjust pulse width VERNIER 8 to obtain 0.1ms pulse width.
- 4 Adjust 1821A Delay (Div) vernier until intensified spot coincides with trailing edge of first pulse.
- 5 Switch to Delayed Sweep and center pulse as shown.
- 6 Display should be:
- 7 Measure pulse width jitter:

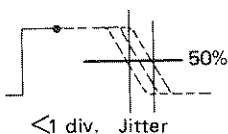
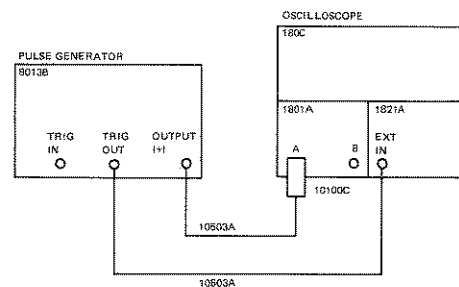

Table 5-9. Performance Test: Square Wave



INITIAL CONTROL SETTINGS

PULSE PERIOD	2	20n-1μ
VERNIER	3	CCW
PULSE DOUBLE/NORM	4	NORM
PULSE DELAY	5	35n-1μ
VERNIER	6	CW
PULSE WIDTH	7	SQUARE WAVE
VERNIER	8	CW
AMPLITUDE	9	5.0-2.0
VERNIER	10	CW
OFFSET vernier	11	-
OFFSET switch	12	OFF
AMPLITUDE	13	5.0-2.0
VERNIER	14	CW
OFFSET vernier	15	-
OFFSET switch	16	OFF
NORM/COMPL	19	NORM
INT LOAD	20	IN
EXT WIDTH/NORM/RZ	25	NORM

STEP INSTRUCTIONS

RESU

- 1 For each setting of the PULSE PERIOD switch 2, given in the table below, turn the VERNIER 3 slowly from fully CCW to fully CW and check that the PULSE DELAY 5 and VERNIER 6 controls have minimal effect on the position of the displayed pulse.

PULSE PERIOD	VERNIER	Symme
2	3	
20n - 1μ	CCW to CW	50% ±
1μ - .1m	CCW to CW	50% ±
.1m - 10m	CCW to CW	50% ±
10m - 1	CCW to CW	50% ±
- 2 For all settings of the pulse period control check that the pulse width equals pulse OFF time within the above

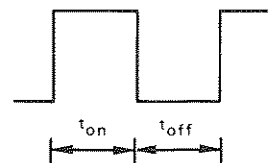
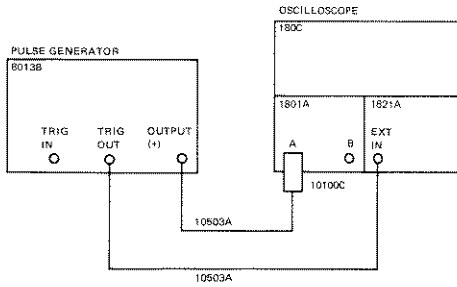

Table 5-10. Performance Test: Duty Cycle



INITIAL CONTROL SETTINGS

PULSE PERIOD 2	1μ-.1m
VERNIER 3	CW
PULSE DOUBLE/NORM 4	NORM
PULSE DELAY 5	35n-1μ
VERNIER 6	CCW
PULSE WIDTH 7	1μ-.1m
VERNIER 8	CCW
AMPLITUDE 9	5.0-2.0
VERNIER 10	CW
OFFSET vernier 11	-
OFFSET switch 12	OFF
AMPLITUDE 13	5.0-2.0
VERNIER 14	CW
OFFSET vernier 15	-
OFFSET switch 16	OFF
NORM/COMPL 19	NORM
INT LOAD 20	IN
EXT WIDTH/NORM/RZ 25	NORM

STEP INSTRUCTIONS RESULTS

- For each set of control settings given in table below, display the output pulse so that it occupies half of the display (see diagram below).

Starting with the pulse period VERNIER 3 fully CW turn VERNIER 3 slowly CCW until the trailing edge of the pulse begins to move or the pulse divides. When this happens measure the pulse period (Tp) and use in the formula:

$$\text{Duty Cycle Max} = \frac{\text{Pulse Width (Tw)}}{\text{Pulse Period (Tp)}} \times 100\%$$

PULSE PERIOD 2	PULSE WIDTH 7	VERNIER 8	
1μ-.1m	1μ-.1m	Adjust for 1μs	> 75%
.1m-10m	.1m-10m	Adjust for 0.1ms	> 75%
10m-1	10m-1	Adjust for 10ms	> 75%

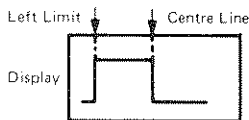
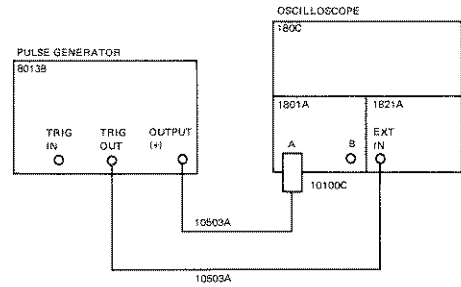

Table 5-11. Performance Test: Manual Operation



INITIAL CONTROL SETTINGS

PULSE PERIOD 2	EXT(+)
VERNIER 3	-
PULSE DOUBLE/NORM 4	NORM
PULSE DELAY 5	35n-1μ
VERNIER 6	CCW
PULSE WIDTH 7	1μ-.1m
VERNIER 8	CW
AMPLITUDE 9	5.0-2.0
VERNIER 10	CW
OFFSET vernier 11	-
OFFSET switch 12	OFF
AMPLITUDE 13	5.0-2.0
VERNIER 14	CW
OFFSET vernier 15	-
OFFSET switch 16	OFF
NORM/COMPL 19	NORM
INT LOAD 20	IN
EXT WIDTH/NORM/RZ 25	NORM

STEP INSTRUCTIONS

- Press MAN button 1

Only one output pules must occur when the button is pressed, no pulse must occur when the button is released.

Table 5-12. Performance Test: External Width Operation

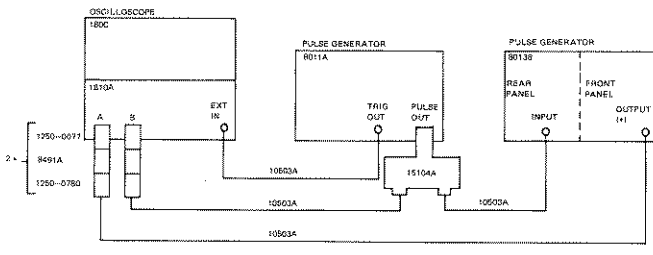

INITIAL CONTROL SETTINGS

PULSE PERIOD	2	—
VERNIER	3	—
PULSE DOUBLE/NORM	4	—
PULSE DELAY	5	—
VERNIER	6	—
PULSE WIDTH	7	—
VERNIER	8	—
AMPLITUDE	9	5.0-2.0
VERNIER	10	CW
OFFSET vernier	11	—
OFFSET switch	12	OFF
AMPLITUDE	13	5.0-2.0
VERNIER	14	CW
OFFSET vernier	15	—
OFFSET switch	16	OFF
NORM/COMPL	19	NORM
INT LOAD	20	IN
EXT WIDTH/NORM/RZ	25	EXT WIDTH

STEP INSTRUCTIONS

1	Apply external signals to INPUT	26
---	---------------------------------	----

NOTE

The 1 V signal applied to 8013B INPUT 26 is displayed on the oscilloscope as 100 mV due to the HP 8491A attenuator.

- 2 Note that the leading and trailing edges of the output pulses are delayed on the input pulses by a fixed delay of approx. 30ns. This is the propagation delay of the 8013B internal circuitry.

RESULT

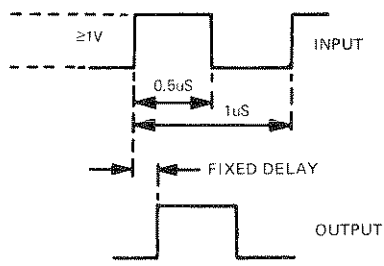
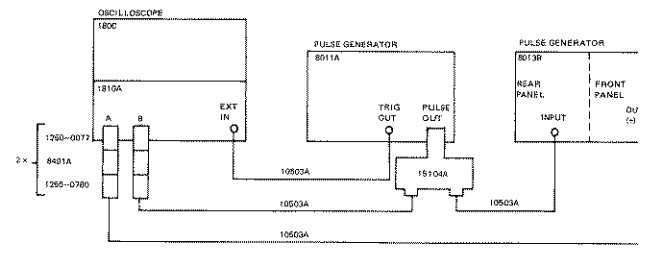

Table 5-13. Performance Test: RZ Operation



INITIAL CONTROL SETTINGS

PULSE PERIOD	2	EXT(+)
VERNIER	3	—
PULSE DOUBLE/NORM	4	NORM
PULSE DELAY	5	35n-1µ
VERNIER	6	CCW
PULSE WIDTH	7	10n-1µ
VERNIER	8	Center
AMPLITUDE	9	5.0-2.0
VERNIER	10	CCW
OFFSET vernier	11	—
OFFSET switch	12	OFF
AMPLITUDE	13	5.0-2.0
VERNIER	14	CCW
OFFSET vernier	15	—
OFFSET switch	16	OFF
NORM/COMPL	19	NORM
INT LOAD	20	IN
EXT WIDTH/NORM/RZ	25	RZ

STEP INSTRUCTIONS RESULTS

- 1 Apply RZ pulses to INPUT 26

NOTE

The 1 V signal applied to 8013B INPUT 26 is displayed on the oscilloscope as 100 mV due to the HP 8491A attenuator.

- 2 Output should be:
-

- 3 Check that pulse delay VERNIER 6 and pulse width VERNIER 8 vary the pulse delay and pulse width.

Table 5-14. Performance Test: Gate Operation

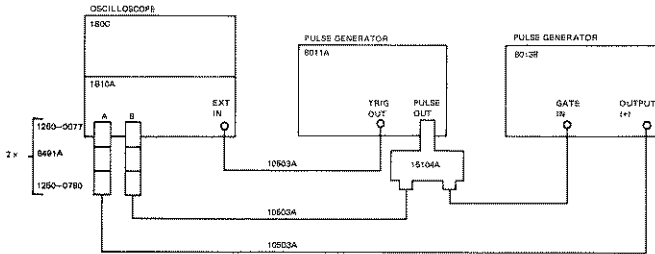

INITIAL CONTROL SETTINGS

PULSE PERIOD 2	20n-1μ
VERNIER 3	Center
PULSE DOUBLE/NORM 4	NORM
PULSE DELAY 5	35n-1μ
VERNIER 6	CCW
PULSE WIDTH 7	10n-1μ
VERNIER 8	50% duty cycle
AMPLITUDE 9	5.0-2.0
VERNIER 10	CCW
OFFSET vernier 11	-
OFFSET switch 12	OFF
AMPLITUDE 13	5.0-2.0
VERNIER 14	CW
OFFSET vernier 15	-
OFFSET switch 16	OFF
NORM/COMPL 19	NORM
INT LOAD 20	IN
EXT WIDTH/NORM/RZ 25	NORM

STEP INSTRUCTIONS

- 1 Apply gate pulse to GATE INPUT 22 .
- 2 Check that output pulses at OUTPUT 17 only occur during ON time of gate pulse: Turn pulse period VERNIER 3 slowly CW and check gate operation for all pulse periods.
- 3 Move cable on OUTPUT(+) 17 to TRIGGER OUTPUT(+) 21.
- 4 Check that leading edge of first trigger output pulse (TRIGGER OUTPUT 21) occurs a short time (owing to fixed delay) after the leading edge of the gate pulse.
- 5 Check that last pulse width is correct even when gate pulse trailing edge occurs just before or during the last pulse (owing to the effect of the fixed delay of approx. 40ns).

RESULTS

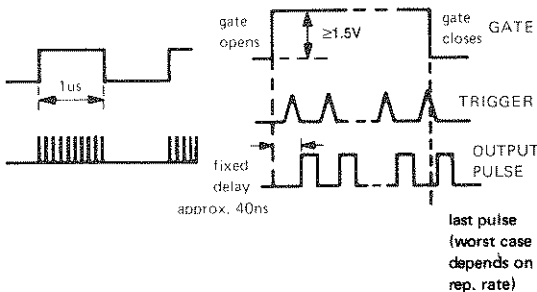
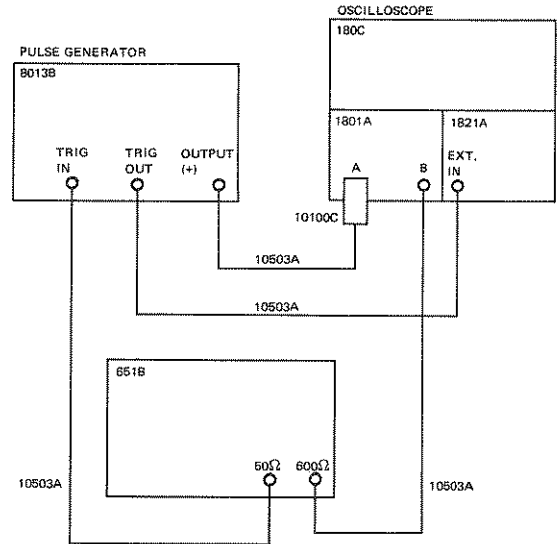

Table 5-15. Performance Test: External Trigger Operation



INITIAL CONTROL SETTINGS

PULSE PERIOD 2	EXT(+)
VERNIER 3	-
PULSE DOUBLE/NORM 4	NORM
PULSE DELAY 5	35n-1μ
VERNIER 6	CCW
PULSE WIDTH 7	.1m-10m
VERNIER 8	CCW
AMPLITUDE 9	5.0-2.0
VERNIER 10	CW
OFFSET vernier 11	-
OFFSET switch 12	OFF
AMPLITUDE 13	5.0-2.0
VERNIER 14	CW
OFFSET vernier 15	-
OFFSET switch 16	OFF
NORM/COMPL 19	NORM
INT LOAD 20	IN
EXT WIDTH/NORM/RZ 25	NORM

STEP INSTRUCTIONS

- 1 Set the 651B controls as follows:
 Range X100
 Vernier 2.5
 Attenuator +10dB (1.0V)
 Amplitude 0.61V RMS
 Frequency 1kHz
- 2 Center the waveforms on the oscilloscope display and check that the leading edge of the output pulse occurs during positive slope of the sinewave.
- 3 Set PULSE PERIOD 2 to EXT (-). The leading edge of the output pulse should occur during the negative slope of the sinewave.

Table 5-16. Performance Test: High Frequency Trigger Operation

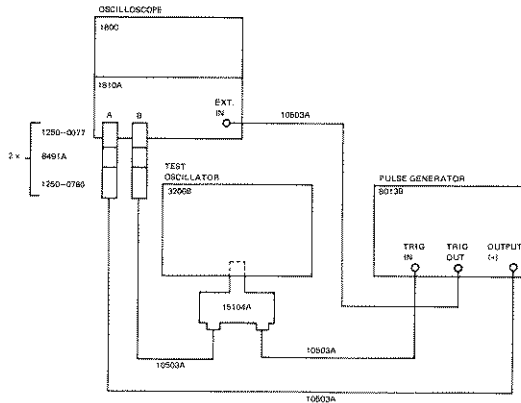

INITIAL CONTROL SETTINGS

PULSE PERIOD 2	EXT(+)
VERNIER 3	—
PULSE DOUBLE/NORM 4	NORM
PULSE DELAY 5	35n-1μ
VERNIER 6	CCW
PULSE WIDTH 7	10n-1μ
VERNIER 8	CCW
AMPLITUDE 9	5.0-2.0
VERNIER 10	CW
OFFSET vernier 11	—
OFFSET switch 12	OFF
AMPLITUDE 13	5.0-2.0
VERNIER 14	CW
OFFSET vernier 15	—
OFFSET switch 16	OFF
NORM/COMPL 19	NORM
INT LOAD 20	IN
EXT WIDTH/NORM/RZ 25	NORM

STEP INSTRUCTIONS

- 1 Apply a sinewave with a repetition rate of 50 MHz and amplitude of 1.7V p-p. Check that repetition rate of output is equal to repetition rate of input i.e. 50 MHz.

NOTE

The 1.7 V p-p signal applied to 8013B TRIGGER INPUT 23 is displayed on the oscilloscope as 170 mV due to the HP 8491A attenuator.

- 2 Set PULSE PERIOD 2 to EXT —.
- 3 Repeat step 1.

Note that there is a delay of 25ns ± 8ns between the trigger input and output.

Table 5-17. Performance Test: Trigger Output

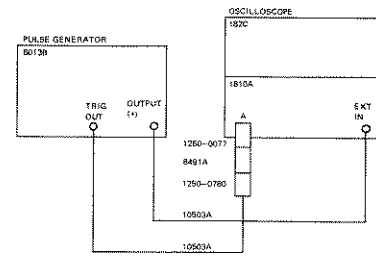

INITIAL CONTROL SETTINGS

PULSE PERIOD 2	20n-1μ
VERNIER 3	CCW
PULSE DOUBLE/NORM 4	NORM
PULSE DELAY 5	35n-1μ
VERNIER 6	CCW
PULSE WIDTH 7	10n-1μ
VERNIER 8	CCW
AMPLITUDE 9	2.0-1.0
VERNIER 10	CW
OFFSET vernier 11	—
OFFSET switch 12	OFF
AMPLITUDE 13	2.0-1.0
VERNIER 14	CW
OFFSET vernier 15	—
OFFSET switch 16	OFF
NORM/COMPL 19	NORM
INT LOAD 20	IN
EXT WIDTH/NORM/RZ 25	NORM

STEP INSTRUCTIONS

RESULTS

- | | | |
|---|--|--------|
| 1 | Measure amplitude of trigger output pulse (TRIGGER OUTPUT) | > 1.0V |
|---|--|--------|

NOTE

The 1.0 V TRIGGER OUTPUT pulse of the 8013B is displayed on the oscilloscope as 100 mV due to the HP 8491A attenuator.

- | | | |
|---|--|-----------|
| 2 | Measure width of trigger output pulse at 50% of amplitude: | 16ns ± 10 |
| 3 | Turn VERNIER 3 slowly from CCW to CW, the amplitude and width limits given must be true for the whole range. | |
| 4 | Switch PULSE PERIOD 2 to range 1μ-.1m and repeat steps 1 to 3. | |
| 5 | Switch PULSE WIDTH 7 to SQUARE WAVE and repeat steps 1 to 3. | |

Table 5-18. Performance Test: Preshoot, Overshoot and Ringing

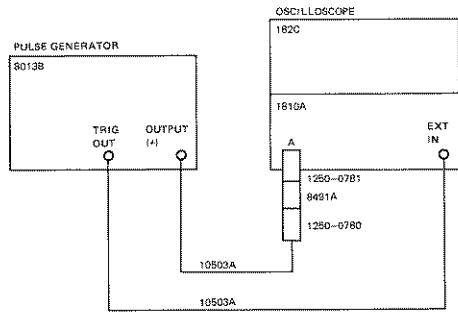

INITIAL CONTROL SETTINGS

PULSE PERIOD	2	20n-1μ
VERNIER	3	CCW
PULSE DOUBLE/NORM	4	NORM
PULSE DELAY	5	35n-1μ
VERNIER	6	CCW
PULSE WIDTH	7	SQUARE WAVE
VERNIER	8	-
AMPLITUDE	9	5.0-2.0
VERNIER	10	CW
OFFSET vernier	11	-
OFFSET switch	12	OFF
AMPLITUDE	13	5.0-2.0
VERNIER	14	CW
OFFSET vernier	15	-
OFFSET switch	16	OFF
NORM/COMPL	19	NORM
INT LOAD	20	IN
EXT WIDTH/NORM/RZ	25	NORM

STEP INSTRUCTIONS

- With reference to the diagram below, measure preshoot, overshoot and ringing in turn to ensure that these are <5% of the pulse amplitude.
- Disconnect the oscilloscope input from the 8013B and reconnect to the negative output connector 18. Repeat step 1.

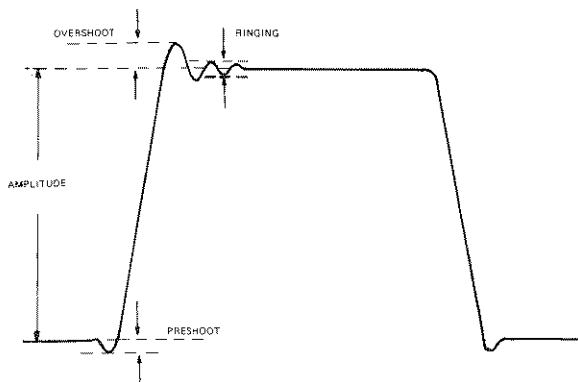
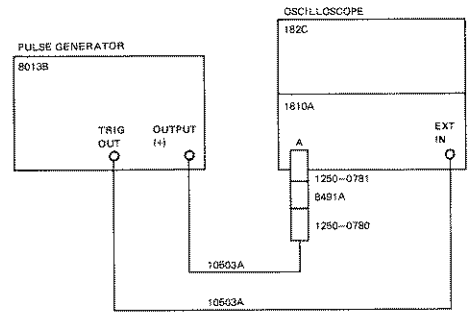

Table 5-19. Performance Test: Amplitude



INITIAL CONTROL SETTINGS

PULSE PERIOD	2	20n-1μ
VERNIER	3	CW
PULSE DOUBLE/NORM	4	NORM
PULSE DELAY	5	35n-1μ
VERNIER	6	CCW
PULSE WIDTH	7	10n-1μ
VERNIER	8	Center
AMPLITUDE	9	5.0-2.0
VERNIER	10	CW
OFFSET vernier	11	-
OFFSET switch	12	OFF
AMPLITUDE	13	5.0-2.0
VERNIER	14	CW
OFFSET vernier	15	-
OFFSET switch	16	OFF
NORM/COMPL	19	NORM
INT LOAD	20	IN
EXT WIDTH/NORM/RZ	25	NORM

STEP INSTRUCTIONS

- Check the amplitude for both VERNIER 10 and 14 extremities of each setting of the AMPLITUDE switch 9 and 13 as follows:

NOTE

Output amplitudes displayed on the oscilloscope will be decreased by a factor of 10 due to the HP 8491A attenuator.

AMPLITUDE 9 13	VERNIER 10 14	INT LOAD	
		IN	OUT
5.0-2.0	CW	≥ 5.0	≥ 10V
5.0-2.0	CCW	≤ 2.0	≤ 4V
2.0-1.0	CW	≥ 2.0	≥ 4V
2.0-1.0	CCW	≤ 1.0	≤ 2V
1.0-.05	CW	≥ 1.0	≥ 2V
1.0-.05	CCW	≤ 0.5	≤ 1V
0.5-0.2	CW	≥ 0.5	≥ 1V
0.5-0.2	CCW	≤ 0.2	≤ 0.4V

- Move cable on OUTPUT(+) 17 to OUTPUT(-) 18 and repeat step 1.

NOTE

If OUTPUT(-) does not meet amplitude requirements, it may be necessary to change the value of A6R56 to 3.48 kohms (HP Part No. 0698-3152).

Table 5-20. Performance Test: DC Offset

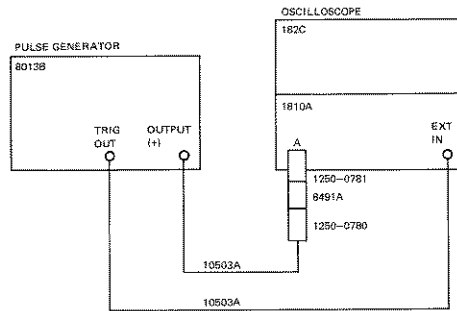

INITIAL CONTROL SETTINGS

PULSE PERIOD 2	20n-1μ
VERNIER 3	CW
PULSE DOUBLE/NORM 4	NORM
PULSE DELAY 5	35n-1μ
VERNIER 6	CCW
PULSE WIDTH 7	10n-1μ
VERNIER 8	Center
AMPLITUDE 9	5.0-2.0
VERNIER 10	CW
OFFSET vernier 11	-
OFFSET switch 12	OFF
AMPLITUDE 13	5.0-2.0
VERNIER 14	CW
OFFSET vernier 15	-
OFFSET switch 16	OFF
NORM/COMPL 19	NORM
INT LOAD 20	IN
EXT WIDTH/NORM/RZ 25	NORM

STEP INSTRUCTIONS RESULTS

NOTE

Offset amplitudes displayed on the oscilloscope will be decreased by a factor of 10 due to the HP 8491A attenuator.

- 1 Disconnect 8013B from oscilloscope.
- 2 Center the oscilloscope display trace.
- 3 Reconnect 8013B to oscilloscope.
- 4 Set OFFSET 16 to ON.
- 5 Turn VERNIER 15 fully CCW.
- 6 Measure negative offset: $\geq -2.5V$
- 7 Turn VERNIER 15 fully CW.
- 8 Measure positive offset: $\geq +2.5V$
- 9 Turn OFFSET 16 to OFF.
- 10 Output pulse baseline should be at center of oscilloscope display.
- 11 Connect the oscilloscope input to the 8013B negative output connector 18.
- 12 Repeat steps 1 to 8 for OFFSET 12 and VERNIER 11 but with the following limits:

VERNIER 11 fully CCW	$\geq -2.5V$
VERNIER 11 fully CW	$\geq +2.5V$

Table 5-21. Internal Checks and Adjustments - Power Supply

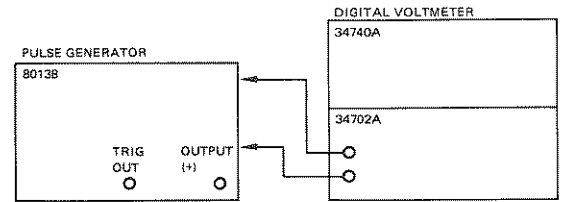

INITIAL CONTROL SETTINGS 8013B:

PULSE PERIOD 2	EXT+
VERNIER 3	CW
PULSE DOUBLE/NORMAL 4	NORM
PULSE DELAY 5	1μ-0.1m
VERNIER 6	CCW
PULSE WIDTH 7	1μ-0.1m
VERNIER 8	CCW
AMPLITUDE 9	5.0-2.0
VERNIER 10	CW
OFFSET switch 12	OFF
AMPLITUDE 13	5.0-2.0
VERNIER 14	CW
OFFSET 16	OFF
NORM/COMPL 19	NORM
INT LOAD 20	IN
EXT WIDTH/NORM/RZ 25	NORM

3444A:
 FUNCTION switch VOLTS
 RANGE switch 100V

STEP INSTRUCTION

- 1 Connect the DVM between the +17VTP on board A6 and GND. Adjust A6R102 for +17V ± 100mV.
- 2 Connect the DVM between the -17V TP on board A6 and GND. Adjust A6R106 for -17V ± 100mV.

BOARD A6

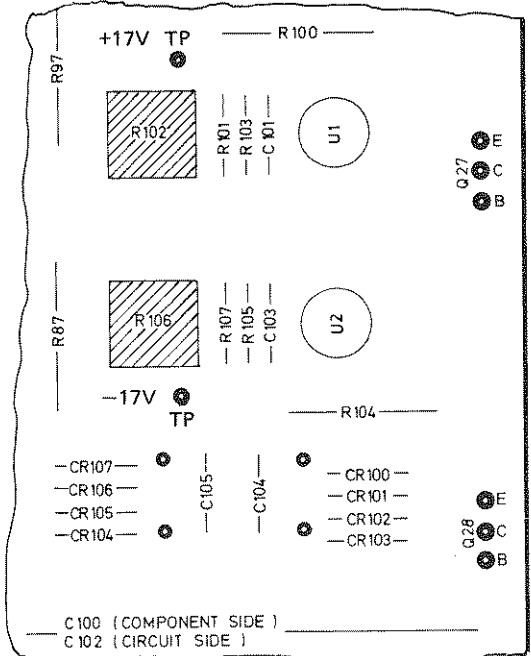
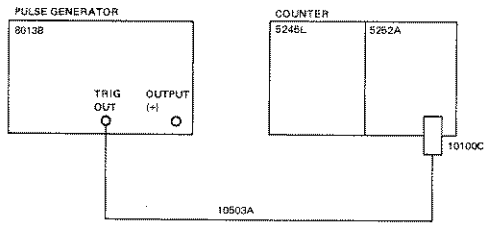

Table 5-22. Internal Checks and Adjustments - Repetition Rate



INITIAL CONTROL SETTINGS 8013B:

PULSE PERIOD	2	20n-1μ
VERNIER	3	CCW
PULSE DOUBLE/NORMAL	4	NORM
PULSE DELAY	5	35n-1μ
VERNIER	6	CCW
PULSE WIDTH	7	10n-1μ
VERNIER	8	CCW
AMPLITUDE	9	5.0-2.0
VERNIER	10	CW
OFFSET switch	12	OFF
AMPLITUDE	13	5.0-2.0
VERNIER	14	CW
OFFSET	16	OFF
NORM/COMPL	19	NORM
INT LOAD	20	IN
EXT WIDTH/NORM/RZ	25	NORM

5252A:

MAX COUNT RATE	100MC
----------------	-------

5245L:

SENSITIVITY	0.1V
SIGNAL INPUT	AC
TIME BASE	0.1m
FUNCTION	FREQUENCY

STEP INSTRUCTION

- 1 Adjust capacitor A5C24 for a nominal frequency of 51.5 MHz.
Limits > 51 MHz < 52 MHz.

BOARD A5

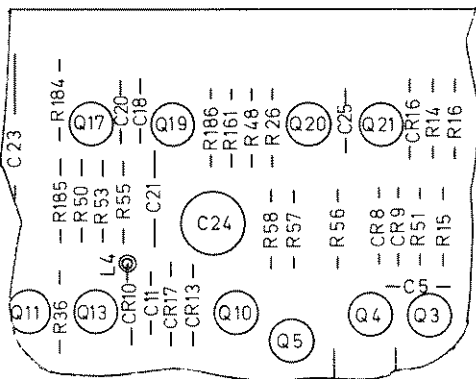
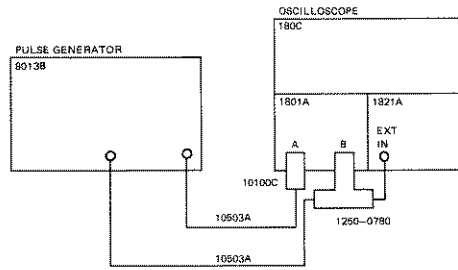

Table 5-23. Internal Checks and Adjustments – Delay and Width Timing



INITIAL CONTROL SETTINGS 8013B:

PULSE PERIOD	2	1μ-0.1m
VERNIER	3	CW
PULSE DOUBLE/NORMAL	4	NORM
PULSE DELAY	5	35n-1μ
VERNIER	6	CW
PULSE WIDTH	7	10n-1μ
VERNIER	8	CW
AMPLITUDE	9	5.0-2.0
VERNIER	10	CW
OFFSET switch	12	OFF
AMPLITUDE	13	5.0-2.0
VERNIER	14	CW
OFFSET	16	OFF
NORM/COMPL	19	NORM
INT LOAD	20	IN
EXT WIDTH/NORM/RZ	25	NORM

1. PULSE DELAY

STEP INSTRUCTION

- 1 Set up the oscilloscope as follows:

1801A:
 DISPLAY ALT, channel B
 VOLTS/DIV 2V
 POLARITY + UP, DC INPUT

1821A:
 TIME/DIV 0.2μs

- 2 Set the leading edge of the trigger output pulse on the first vertical line on the screen. Measure the time to the leading edge of the output pulse. Adjust A5C35 for a nominal 1.2μs. Limits > 1.1μs < 1.35μs.

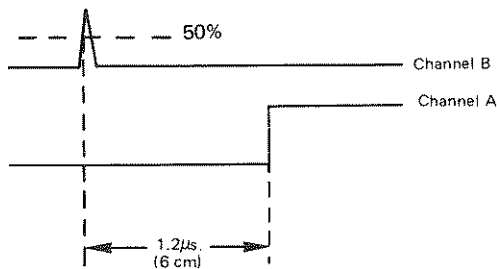

2. PULSE WIDTH

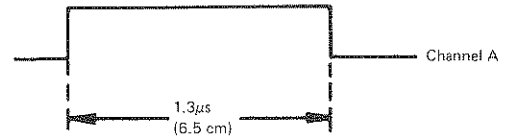

STEP INSTRUCTION

- 1 Set the oscilloscope DISPLAY switch to CHANNEL A only.
- 2 Set the pulse leading edge on the first line of the screen. Adjust A5C45 for a nominal 1.3μs. Limits > 1.1μs < 1.5μ (minimum width with vernier 8 in CCW position is < 10ns using a sampling oscilloscope).

BOARD A5

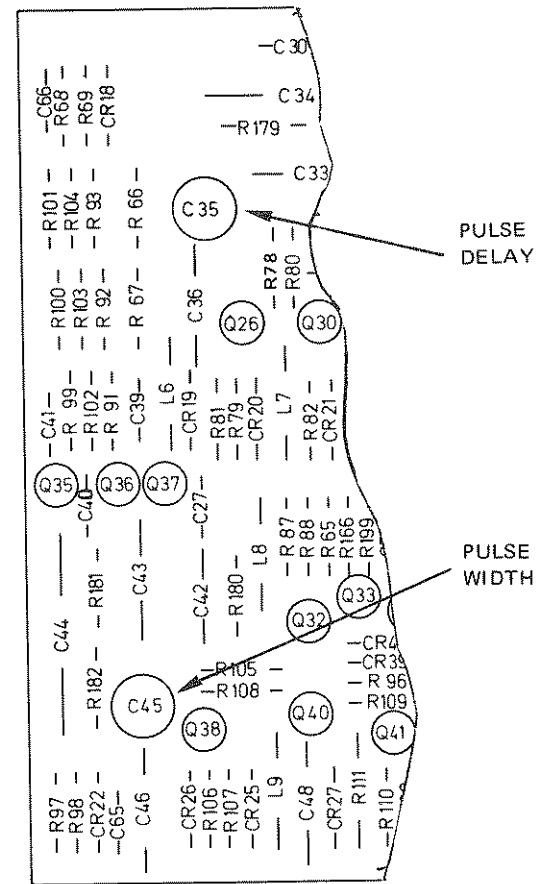
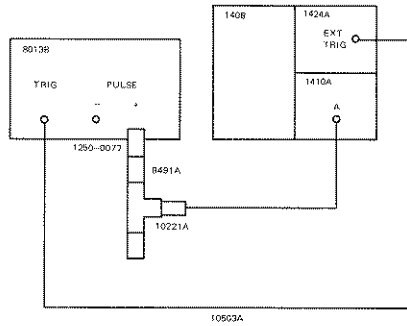

Table 5-24. Internal Checks and Adjustments — Pulse Perturbation



INITIAL CONTROL SETTINGS 8013B:

PULSE PERIOD	2	20n-1μ
VERNIER	3	see step 2
PULSE DOUBLE/NORMAL	4	NORM
PULSE DELAY	5	35n-1μ
VERNIER	6	CCW
PULSE WIDTH	7	10n-1μ
VERNIER	8	CCW
AMPLITUDE	9	5.0-2.0
VERNIER	10	CW
OFFSET switch	12	OFF
AMPLITUDE	13	5.0-2.0
VERNIER	14	CW
OFFSET	16	OFF
NORM/COMPL	19	NORM
INT LOAD	20	IN
EXT WIDTH/NORM/RZ	25	NORM

STEP INSTRUCTION

- 1 Adjust the amplitude vernier 14 for the + channel to obtain a 8 cm deflection.
- 2 Adjust the period vernier 3 to display two periods on the screen.
- 3 Measure the pulse transition times; they should be < 3.5ns.
- 4 Measure the preshoot, overshoot and ringing; they should both be < 5% of pulse amplitude.
- 5 Adjust A6C25 and A6R25 for the best compromise between overshoot and rise time.
- 6 Disconnect the scope from the positive pulse output and connect it to the negative pulse output.
- 7 Repeat steps 1 to 5 for the negative channel and adjust the pulse shape using A6C65 and A6R65.

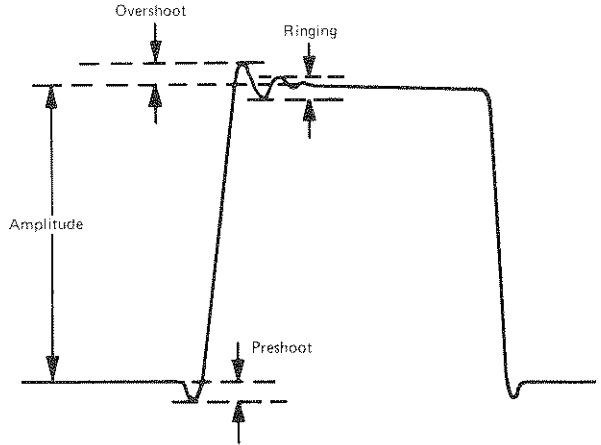

BOARD A6

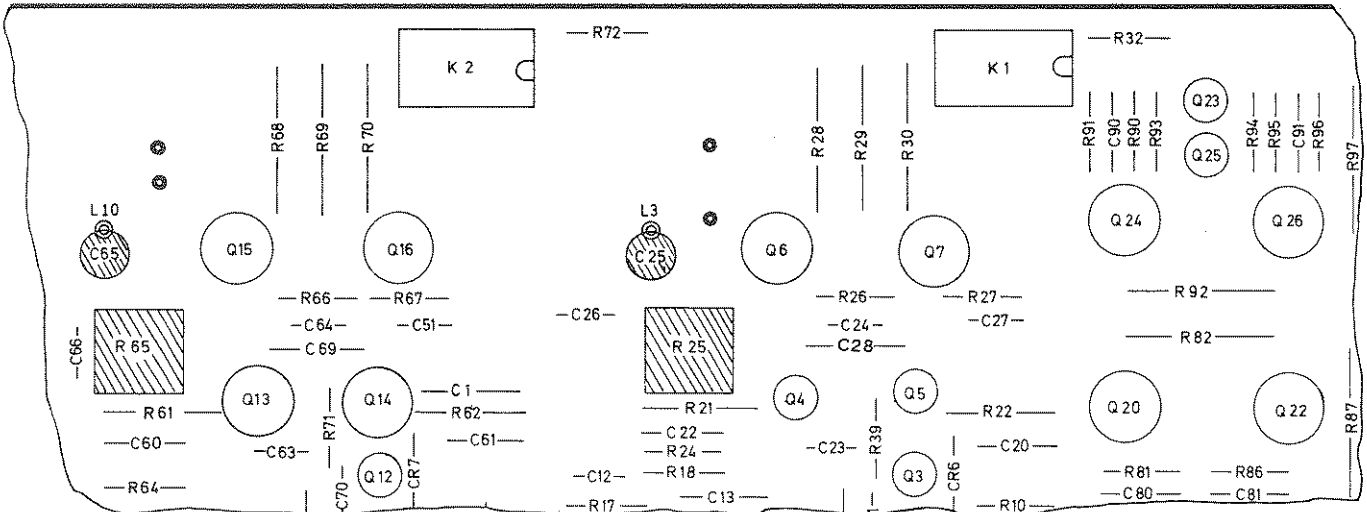
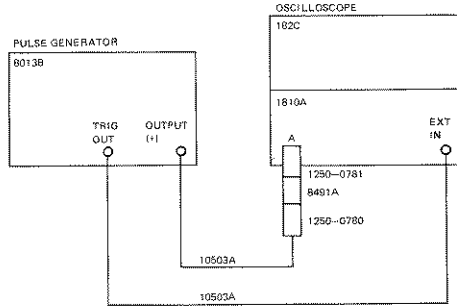

Table 5-25. Internal Checks and Adjustments — Double Pulse



INITIAL CONTROL SETTINGS

PULSE PERIOD 2	20n-1μ
VERNIER 3	center
PULSE DOUBLE/NORM 4	NORM
PULSE DELAY 5	35n-1μ
VERNIER 6	CCW
PULSE WIDTH 7	10n-1μ
VERNIER 8	CCW
AMPLITUDE 9	5.0-2.0
VERNIER 10	CW
OFFSET vernier 11	-
OFFSET switch 12	OFF
AMPLITUDE 13	5.0-2.0
VERNIER 14	CW
OFFSET vernier 15	-
OFFSET switch 16	OFF
NORM/COMPL 19	NORM
INT LOAD 20	IN
EXT WIDTH/NORM/RZ 25	NORM

STEP INSTRUCTION

- 1 Position the output pulse on the oscilloscope screen.
- 2 Adjust A5C45 for $\leq 9.5\text{ns}$ pulse width at 50% of pulse amplitude.
- 3 Set the 8013B pulse double/norm switch to double.
- 4 Adjust PULSE DELAY VERNIER 6 to produce a first (undelayed) pulse of $\geq 20\text{ns}$ between the pulse leading ed
- 5 Adjust A5R188 to produce a first (undelayed) pulse of the same width as the delayed pulse (9.5ns - see step 2)

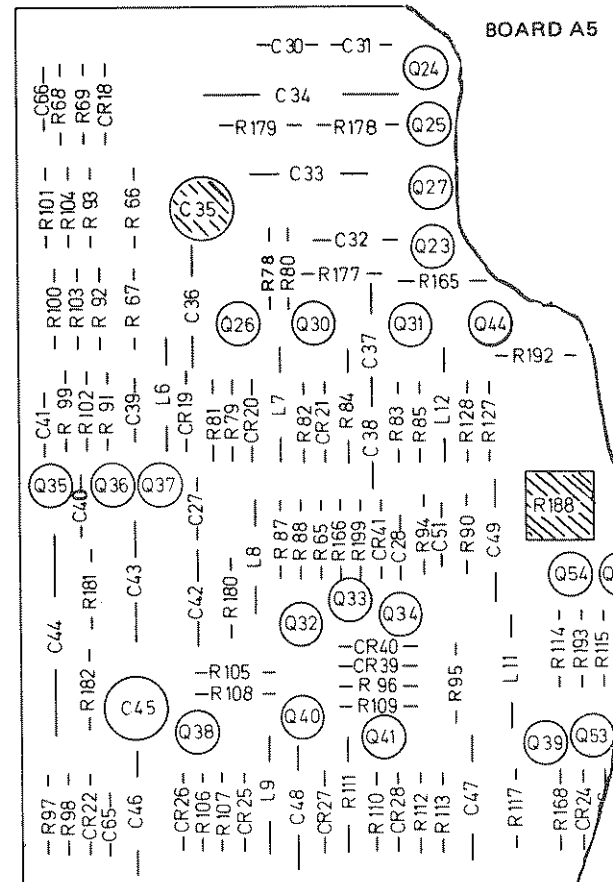
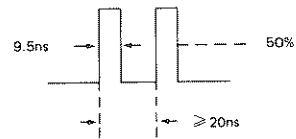
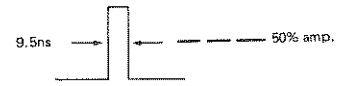

R169 - (55)

Table 5-26. Service Product Safety Check

STEP INSTRUCTION

- | STEP | INSTRUCTION |
|------|--|
| 1 | Visually inspect interior of 8013B for any signal of abnormal internally generated heat, such as discolored printed circuit boards or components, damaged insulation, or evidence of arcing. Determine and remedy cause of any such condition if the product is in warranty. Disconnect power cord from line. |
| 2 | Check resistance from 8013B cabinet to ground pin on power plug with suitable ohmmeter. The reading must be less than one ohm. Flex the power cord while making this measurement to detect any intermittent discontinuity. Check internal ground connections on boards and frame. Also check resistance of any front or rear panel ground terminals marked  . |
| 3 | Check resistance from 8013B cabinet to line and neutral (tied together) with the power switch on and the power source disconnected. The minimum acceptable resistance is two megohms. Replace any component which results in a failure or refer to production Memo or Service Note issued by product division for alternate action. |
| 4 | Check the line fuses to verify that the correct values are installed. |
| 5 | Check that the line voltage selector is set to the customers requirements. |
| 6 | Check that all coaxial cables and wires inside the 8013B are properly connected. Check that all boards are properly connected and that there is good thermal contact between the power supply transistors and the rear panel heat sink. |
| 7 | Inform the responsible product division of any repeated failures in the above tests or any other safety features. |

6-1 INTRODUCTION

6-2 This section contains the circuits, component location diagrams and the lists of replaceable parts. Waveforms shown with the circuits are included for guidance only and failure to observe identical results should not be automatically taken as indication of a fault.

6-3 ORDERING INFORMATION

6-4 General

6-5 The replaceable parts tables give parts in alphanumeric order of their reference designators and indicate the description and HP stock number of each part, together with any applicable notes.

6-6 To order a replacement part, address order or enquiry either to your authorized Hewlett-Packard sales representative or to:

CUSTOMER SERVICE

Hewlett-Packard Company,
333 Logue Avenue,
Mountain View, California 94040

or, in Western Europe, to:

Hewlett-Packard (Schweiz) SA
Rue du Bois-du-Lan 7
1217 Meyrin 2
Geneva

6-7 Specify the following information for each part:

- a) Model and complete serial number of instrument.
- b) Hewlett-Packard stock number.
- c) Circuit reference stock number.
- d) Description.

To order a part not listed, give a complete description of the part and include its function and location.

Table 6-1. Reference Designator

A	= assembly	U	= micro-circuit
B	= motor	P	= plug
BT	= battery	Q	= transistor
C	= capacitor	R	= resistor
CP	= coupler	RT	= thermistor
CR	= diode	S	= switch
DL	= delay line	T	= transformer
DS	= lamp	TB	= terminal board
F	= fuse	V	= vacuum, tube, neon bulb, photocell, etc.
FL	= filter	VR	= voltage regulator
HR	= heater	W	= cable
J	= jack	X	= socket
K	= relay	Y	= crystal
L	= inductor	TP	= test point
M	= meter		

Table 6-2, Diagram Notes

Unless otherwise stated:

capacitance in microfarads
 inductance in microhenries
 resistance in ohms



Chassis/Ground

P/O

Part Of

F.S.

Factory Selected

Wiring colour code:

- 0 black
- 1 brown
- 2 red
- 3 orange
- 4 yellow
- 5 green
- 6 blue
- 7 violet
- 8 grey
- 9 white



Zener Diode

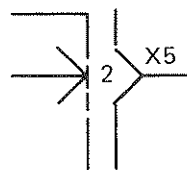

Printed circuit board edge connector and socket (X5) with pin number (2).



Encloses front panel nomenclature

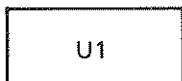

Microcircuit

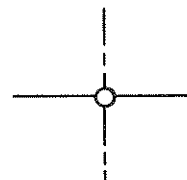

Single pin or soldered connection.



Screwdriver Adjustment

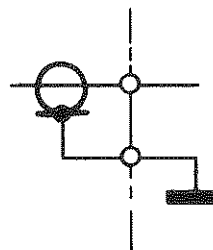

Coaxial Connector Bolt down cable bush



Primary Signal Path

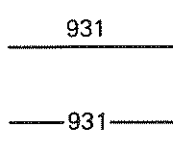

Indicates wire colour using resistor colour code.

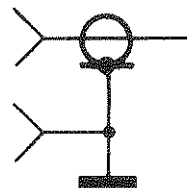

Coaxial Connector bulkhead mounted.



Coaxial cable

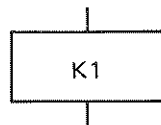

Relay