

OPERATING AND SERVICE MANUAL

PULSE GENERATOR 8013A

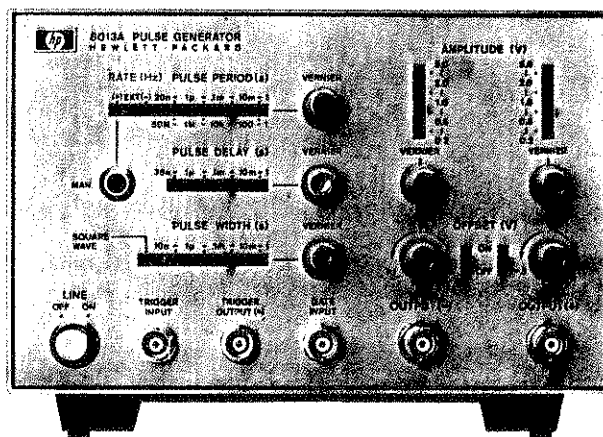

HEWLETT  PACKARD

CERTIFICATION

The Hewlett-Packard Company certifies that this instrument was thoroughly tested and inspected and found to meet its published specifications when it was shipped from the factory. The Hewlett-Packard Company further certifies that its calibration measurements are traceable to the U.S. National Bureau of Standards for AC measurements and the Physikalisch Technische Bundesanstalt for DC measurements to the extent allowed by the Bureau's calibration facility.

WARRANTY AND ASSISTANCE

All Hewlett-Packard products are warranted against defects in materials and workmanship. This warranty applies for one year from the date of delivery, or, in the case of certain major components listed in the operating manual, for the specified period. We will repair or replace products which prove to be defective during the warranty period. No other warranty is expressed or implied. We are not liable for consequential damages.

For any assistance contact your nearest Hewlett-Packard Sales and Service Office. Addresses are provided at the back of this manual.

OPERATING AND SERVICE MANUAL

**MODEL 8013A
PULSE GENERATOR**

This manual corresponds to
instruments with the serial
prefix: 1121G

COPYRIGHT HEWLETT-PACKARD GMBH 1971

703 BÖBLINGEN, HERRENBERGER STR. 110, WEST GERMANY

CONTENTS

Section		Page
I	GENERAL INFORMATION	
	1-1 Introduction	1-3
	1-4 Accessories Available	1-4
	1-6 Manual Identification	1-4
1-8	Ordering Additional Manuals	1-4
II	INSTALLATION	
	2-1 Initial Inspection	2-1
	2-4 Preparation for Use	2-1
	2-7 Power Cable	2-1
	2-9 Temperature Requirements	2-1
	2-11 Repacking	2-1
III	OPERATING INSTRUCTIONS	
	3-1 Introduction	3-1
	3-3 Basic Operating Guide	3-1
	3-5 Normal Mode	3-1
	3-7 Internal Trigger	3-1
	3-9 External Trigger	3-2
	3-11 Manual	3-2
	3-13 Square Wave	3-3
	3-15 Gating	3-3
	3-17 RZ Mode	3-3
	3-19 External Width Mode	3-4
IV	MAINTENANCE	
	4-1 Introduction	4-1
	4-3 Testing, Troubleshooting and Adjustment	4-1
	4-5 Organisation	4-1
	4-9 Test Equipment	4-1
	4-11 Troubleshooting Charts	4-1
	4-13 Removal and Replacement of Covers and Assemblies	4-1
	4-14 Access to Test Points and Assemblies	4-1
	4-16 Removal of Assemblies	4-1
V	DIAGRAMS AND REPLACEABLE PARTS	
	5-1 Introduction	5-1
	5-3 Assembly and Component Referencing	5-1
	5-5 Organization of Diagrams	5-1
	5-10 Ordering Information	5-1
	5-11 General	5-1
	5-15 Assembly Exchange Programs	5-1

ILLUSTRATIONS

Number		Page
1-1	HP Model 8013A Pulse Generator	1-3
2-1	Pulse Generator and Supplied Accessories	1-4
3-1	The 'Normal' Pulse	3-1
3-2	Examples of Internally Triggered Waveforms	3-2
3-3	Examples of Externally Triggered Waveforms	3-2
3-4	Output Waveforms for Manual Operation	3-2
3-5	Examples of Square Wave Output Waveforms	3-3
3-6	Examples of Gated Output Waveforms	3-3
3-7	Examples of RZ Mode Waveforms	3-4
3-8	Comparison of Input and Output Pulse Widths	3-4
4-1	Organization of Tests and Troubleshooting	4-2
5-1	8013A Front and Rear Panels: Control Identification Diagrams	5-3
5-2	Block Diagram	5-5
5-3	Location of Assemblies	5-7
5-4	Troubleshooting Flowchart: Normal Mode - Internal Trigger	5-9
5-5	Troubleshooting Flowchart: Normal Mode - External Trigger	5-13
5-6	Troubleshooting Flowchart: Normal Mode - Gate	5-15
5-7	Troubleshooting Flowchart: Normal Mode - Square Wave	5-17
5-8	Troubleshooting Flowchart: RZ Mode	5-19
5-9	Troubleshooting Flowchart: External Width Mode	5-21
5-10	Component Layout: Assembly 1	5-22
5-11	Circuit Diagram: Assembly 1	5-25
5-12	Component Layout: Assemblies 2 and 3	5-32 5-36
5-13	Circuit Diagram: Assemblies 2 and 3	5-35 5-37
5-14	Component Layout: Assembly 4	5-38
5-15	Circuit Diagram: Assembly 4 and Power Supplies	5-39

TABLES

Number		Page
1-1	Specifications	1-1
3-1	8013A Initial Settings	3-1
4-1	Test Equipment and Accessories	4-3
4-2	Preliminary Check: Internal Operation	4-4
4-3	Preliminary Check: External Operation	4-5
4-4	Preliminary Check: High Frequency Trigger Operation	4-6
4-5	Preliminary Check: Manual Operation	4-7
4-6	Preliminary Check: External Width Operation	4-8
4-7	Preliminary Check: RZ Operation	4-9
4-8	Preliminary Check: Gate Operation	4-10
4-9	Performance Test: Preshoot, Overshoot and Ringing	4-11
4-10	Performance Test: Pulse Period	4-12
4-11	Performance Test: Pulse Period Jitter	4-13
4-12	Performance Test: Pulse Delay	4-14
4-13	Performance Test: Pulse Delay Jitter	4-15
4-14	Performance Test: Pulse Width (greater than 1uS)	4-16
4-15	Performance Test: Pulse Width (less than 10nS)	4-17
4-16	Performance Test: Pulse Width Jitter	4-18
4-17	Performance Test: Square Wave	4-19
4-18	Performance Test: Duty Cycle	4-20
4-19	Performance Test: Trigger Output	4-21
4-20	Performance Test: Amplitude	4-22
4-21	Performance Test: DC Offset	4-23
4-22	Performance Test: Baseline Position	4-24
4-23	Performance Test: Output Impedance	4-25
4-24	Initial Settings of 8013A for Internal Checks and Adjustments: Assembly 1	4-26
4-25	Internal Checks and Adjustments: Assembly 1	4-27
4-26	Internal Checks and Adjustments: Assembly 2	4-28
4-27	Internal Checks and Adjustments: Assembly 3	4-29
5-1	General Symbols and Reference Designators	5-2
5-2	Replaceable Parts: Frame	5-6
5-3	Replaceable Parts: Assembly 1	5-23
5-4	Replaceable Parts: Assembly 2	5-32
5-5	Replaceable Parts: Assembly 3	5-36
5-6	Replaceable Parts: Assembly 4	5-38

Table 1–1 Specifications

PULSE CHARACTERISTICS(50 Ω source and load impedance)**Transition Times:** < 3.5 nS fixed**Overshoot and Ringing:** < $\pm 5\%$ of pulse amplitude**Preshoot:** < $\pm 5\%$ of pulse amplitude**Pulse Width:** < 10 nS to 1 S in four ranges. Vernier provides continuous adjustment within ranges.**Width Jitter:** < 0.1% + 50 pS on any width setting.**Maximum Duty Cycle:** > 75% from 1 Hz to 10 MHz, decreasing to $\geq 40\%$ at 50 MHz.**Maximum Output:** 5 V across 50 Ω (10 V across open circuit). Output circuit protected, cannot be damaged by shorting (10V across 50 Ω , when internal 50 Ω load is disconnected).**Attenuator:** Four-step attenuator reduces output voltage to 0.5 V. Vernier provides continuous adjustment between steps and reduces output to 0.2V.**Polarity:** Dual channel, positive and negative output simultaneously.**Source Impedance:** 50 $\Omega \pm 3\%$ shunted by (typically) 20 pF.**DC Offset:** Positive channel: variable from -5 V to +1 V across 50 Ω load. Negative channel: variable from +5 V to -1 V across 50 Ω load.Offset voltage independent of attenuator and amplitude vernier setting, can be switched off. If internal 50 Ω load is disconnected, DC-Offset switches off.**Pulse Delay:** < 35 nS to 1 S (with respect to trigger output) in four ranges; vernier provides continuous adjustment within ranges.**Delay Jitter:** < 0.1% + 50 pS on any delay setting.**REPETITION RATE AND TRIGGER****Repetition:** 1 Hz to 50 MHz in four ranges. Vernier provides continuous adjustment within ranges.**Period Jitter:** < 0.1% + 50 pS on any repetition rate setting.**Square Wave:** 0.5 Hz to 25 MHz in four ranges. Duty cycle 50% $\pm 5\%$ up to 1 MHz, tolerance increases to $\pm 15\%$ at 25 MHz.**Trigger Output:** Amplitude: > +1 V across 50 Ω . Width: 16 nS ± 10 nS. Suitable for triggering another 8013A.**EXTERNAL OPERATION****External Triggering****Repetition Rate:** 0 to 50 MHz. For square wave output, frequency divided by factor 2.**Trigger Input:** Sinewaves > 1.5 Vpp (about zero) or pulses > 0.8V, (positive or negative) at least 7 nS wide.**Delay:** 25 nS ± 8 nS between leading edge of trigger input and trigger output signals.**Maximum Input Amplitude:** ± 7 V**Input Impedance:** 50 $\Omega \pm 10\%$ **Coupling:** DC-Coupled**Manual:** Front panel push button for single pulse.**Gating****Synchronous Gating:** Gating signal turns generator "on". First trigger output pulse is coincident with leading edge of gate pulse. Last output pulse is always generated with normal width even if gate pulse ends during generation of output pulse.**Gate Input:** DC-coupled; voltage at open circuit gate connector approximately +1.8 V. Shorting current ≤ 12 mA. Input impedance approximately 160 Ω **Gate Input Signal:** Voltage > +1.5V or resistor > 300 Ω from gate input to ground enables the repetition rate generator.Voltage < +0.8 V or resistor < 160 Ω disables the repetition rate generator. Gate input is TTL compatible.**Maximum Input Signal:** ± 5 V**External Width and RZ Modes****External Width:** Output pulse width determined by the width of drive input signal. Amplitude selectable. Repetition rate generator running provides trigger output but these trigger pulses are not related to the pulses at the output connector.**RZ Mode:** External drive input switched to delay generator. Pulse period determined by pulse period of drive

Table 1--1 Specifications (cont.)

input signal. Delay, width and amplitude are selectable.

Input Signal: Input Impedance 50Ω , DC-coupled. Signal $> +1V$, at least 7 nS wide, provides output signal.

Maximum Input Signal: $\pm 5V$

Repetition rate generator running provides trigger output but these trigger pulses are not related to the pulses at the output connector.

GENERAL

Operating Temperature Range: $0^{\circ}C$ to $+55^{\circ}C$

Power Requirements: 115 or 230 V $\pm 10\%$, -15% , 48 to 440 Hz, 70 VA maximum.

Weight: Net 9 lbs. (4 kg), shipping 14.6 lbs. (6.5 kg)

Dimensions: 7.9 in. wide, 5.6 in. high, 13 in. deep. (200 x 142 x 330 mm)

SECTION I GENERAL INFORMATION

1-1 INTRODUCTION

1-2 The Hewlett-Packard Model 8013A Pulse Generator is a dual channel, multi-purpose pulse source with variable repetition rate (PULSE PERIOD controls), pulse delay and pulse width. The dual outputs, OUTPUT (+) and OUTPUT (-), are usually developed across a 50 ohm external impedance and have independent amplitude controls. In addition, symmetrical pulse outputs, either as single pulses or pulse trains (in which the positive and negative limits of the respective pulse amplitude are an equal amount above and below ground potential), or a compliment of each pulse, can be obtained by introducing a suitable dc bias (OFFSET controls).

1-3 Three modes of operation are possible as follows:

a) Normal Mode: In this mode the 8013A repetition rate generator determines the pulse period. The generator may be triggered internally, externally, or manually; it may also be gated. Trigger pulses are available for synchronising external circuits; the delay time be-

tween the trigger and the output pulses may be varied as required.

b) RZ Mode: In this mode the external pulses determine only the repetition rate of the output pulses. All other output pulse parameters are determined by the settings of the pulse generator's front panel controls. Pulses produced by the repetition rate generator bear no time relationship to the output pulse train but can be used as an independent trigger for other equipment, if desired. It is not possible to gate the output pulses or to obtain square waves.

c) External Width Mode: Pulses applied to an input socket on the rear panel determine the width and repetition rate of the output pulses. Pulses produced by the repetition rate generator bear no time relationship to them, but can be used as an independent trigger for other equipment, if desired. Note that it is not possible to gate the output pulses and that square wave pulse forms are not available in this mode.

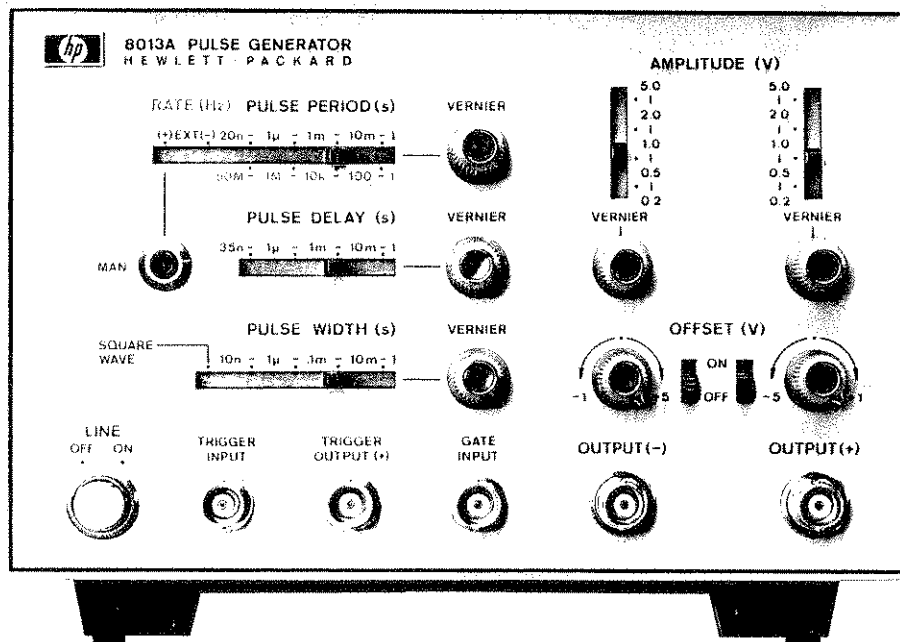

Figure 1-1 HP Model 8013A Pulse Generator

1-4 ACCESSORIES AVAILABLE

1-5 Electronic test equipment, cables, connectors, adaptors, and other accessory items are available from Hewlett-Packard. For more information on specific items consult the Hewlett-Packard Catalog or Sales/Service Office.

1-6 MANUAL IDENTIFICATION

1-7 This instrument carries a 10-character serial number on the rear panel, the first 5 characters of which are termed the serial number prefix. If the prefix does not agree with that quoted on the title page, reference should be made to the change sheets supplied with the manual. To obtain further information for any instru-

ment, contact the nearest Hewlett-Packard Sales/Service Office, always specify the model number and complete serial number.

1-8 ORDERING ADDITIONAL MANUALS

1-9 One manual is shipped with each pulse generator. Additional manuals may be purchased from the local Hewlett-Packard field office (see list at rear of this manual for addresses). Specify the model number, complete serial number prefix, and HP stock number provided on the title page.

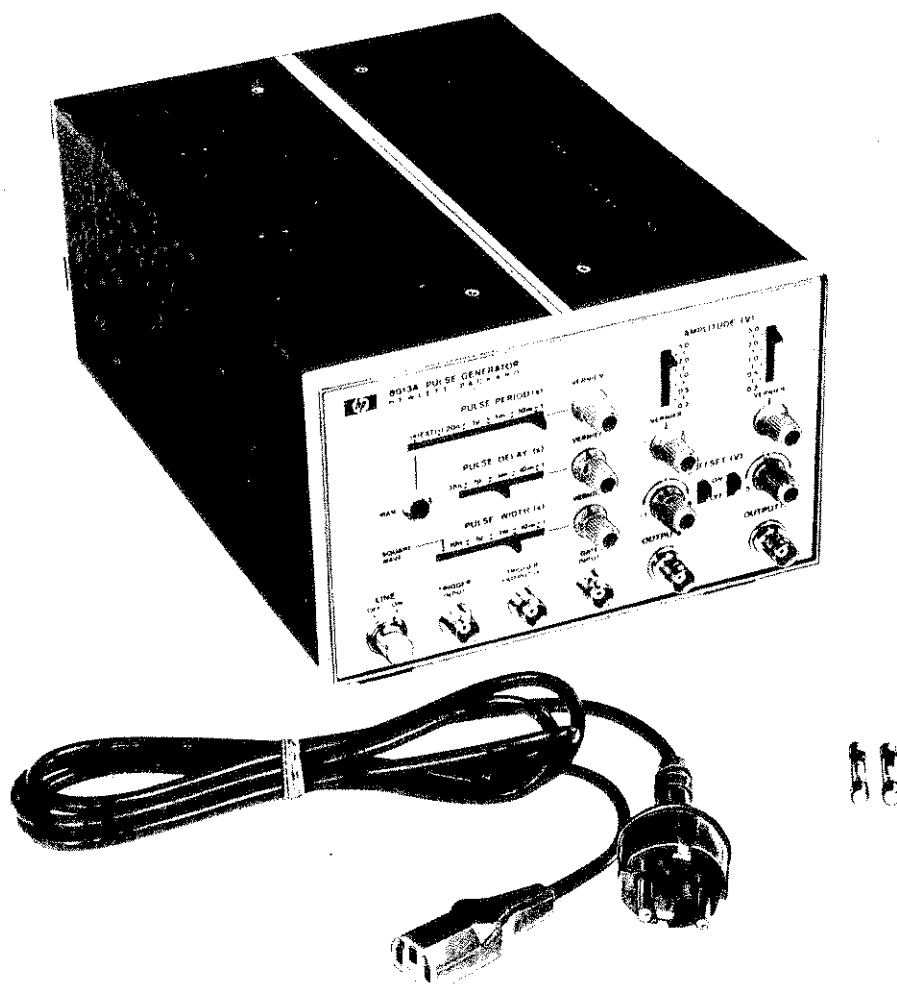

Figure 2-1 Pulse Generator and Supplied Accessories

SECTION II INSTALLATION

2-1 INITIAL INSPECTION

2-2 Inspect the instrument for physical damage and check its operation as soon as possible after delivery. Section IV contains performance check procedures which will verify instrument operation within the published specifications. This check is suitable for incoming quality control inspection. If physical damage is evident, or the instrument does not meet specifications when received, notify the carrier and the nearest Hewlett-Packard Sales/Service Office (see list at rear of this manual). The Sales/Service Office will arrange for repair or replacement without waiting for settlement of a claim with the carrier. The certification and warranty statement for all HP instruments are on the inside cover of this manual.

2-3 The instrument is delivered complete with the following items:

	HP Stock Numbers
Power Cord	8120-1492
Fuse, 0.5 A for 230 V operation	2110-0202
Fuse, 1 A for 115 V operation	2110-0007

2-4 PREPARATION FOR USE

2-5 Power Source Requirements

2-6 The Model 8013A may be operated from an ac source of 115 or 230 volts + 10%, - 15%, at 48 to 440 Hz. Power dissipation is approximately 60 VA. Carry out the following procedure if it is required to change the operating voltage:

- a) Disconnect the power cable from the instrument.
- b) Slide the safety window to the left.
- c) Remove the fuse by pulling the lever marked FUSE PULL; this also releases the voltage selector switch.
- d) Slide the voltage selector switch to the position required (i. e. 115 V or 230 V).

e) Push the lever back into position and place the appropriate fuse in the fuse holder.

f) Slide the safety window to the right and insert the power cable.

CAUTION

Ensure that the number visible on the slide switch and the fuse value correspond to the line voltage used before switching the instrument ON; otherwise, the instrument may be damaged.

2-7 Power Cable

2-8 The Hewlett-Packard Model 8013A is equipped with a 3-wire power cable, which, when connected to an appropriate receptacle, grounds the instrument, cabinet and panels. To preserve this protection feature when operating the instrument from another type of outlet without ground, use an appropriate adapter and connect the ground lead to an external ground.

2-9 Temperature Requirements

2-10 The Hewlett-Packard Model 8013A uses solid-state components and requires no special cooling. The instrument operates within specifications when the ambient temperature is between 0°C (32°F) and 55°C (131°F). The pulse generator may be stored at temperatures between -40°C (-40°F) and 75°C (167°F).

2-11 Repacking

2-12 The original shipping carton and packing material can be used for reshipment. The Hewlett-Packard Sales/Service Office will also provide information and recommendations on materials to be used if the original packing material is not available or is damaged. If the instrument is to be shipped to a Hewlett-Packard Sales/Service Office for repair, attach a tag showing owner, model, serial number, and repairs required.

SECTION III OPERATING INSTRUCTIONS

3-1 INTRODUCTION

3-2 The operating instructions commence with a procedure to display a simple pulse train on an oscilloscope. This is followed by detailed instructions for the use of each control in the three different modes of operation and stylized waveforms are presented to make their effects clear. For ease of operation the following instructions will refer to Figure 5-1 which shows the controls identified by a reference number that also appears in the text in **bold type**. The control functions are indicated on the block diagram (Figure 5-2).

3-3 BASIC OPERATING GUIDE

3-4 The initial settings (Table 3-1) are given to obtain a 'normal' pulse waveform (Figure 3-1) for someone unfamiliar with the operation of the Model 8013A. One, or both, of the pulse output connectors — OUTPUT (+) 21 or OUTPUT (-) 20 — should be connected to a high-frequency oscilloscope via a 50 ohm coaxial cable. The oscilloscope should be terminated by a 50 ohm load and set with sweep time at 2 us/cm and with sensitivity at 1V/cm.

LINE 16	ON
PULSE PERIOD 1	1u - .1m
VERNIER 2	Mid-range
PULSE DELAY 6	35n - 1u
VERNIER 7	CCW
PULSE WIDTH 10	1u - .1m
VERNIER 11	CCW
Mode Selector 22	NORM
AMPLITUDE 3	5.0 - 2.0
AMPLITUDE 4	5.0 - 2.0
VERNIER 8	CW
VERNIER 9	CW
OFFSET 13	OFF
OFFSET 14	OFF

Table 3-1. 8013A Initial Settings

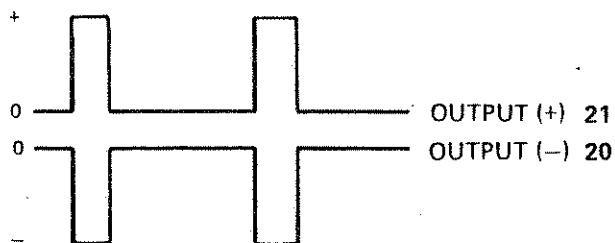

Figure 3-1. The 'normal' pulse

3-5 NORMAL MODE

3-6 There are five ways of operating the pulse generator in the normal mode:

- a) Where the pulse period is determined internally.
- b) As above, but with the repetition rate generator triggered externally.
- c) Manual trigger
- d) In each of the above, square wave output may be selected instead of the variable pulse width.
Note that the square wave output is available only in the normal mode of operation.
- e) The repetition rate generator may also be gated (except in square wave mode).

All output pulses are preceded by a trigger pulse at the TRIGGER OUTPUT socket 18. The delay is fixed at approximately 35 nS for square waves but may otherwise be varied by the PULSE DELAY switch 6 and the VERNIER 7.

3-7 Internal Trigger

3-8 Use the following procedure to obtain pulse outputs similar to those shown in Figure 3-2.

- a) Set the Mode Selector 22 to NORM.
- b) Set the PULSE PERIOD switch 1 to the required range and adjust VERNIER 2 to obtain the exact pulse period.
- c) Set the PULSE DELAY switch 6 to the required range and adjust VERNIER 7 until the required delay between the trigger and the output pulse is obtained. Note that the pulse delay and pulse width time must always be less than 75 % of the pulse period.

- d) Set the PULSE WIDTH switch 10 to the required range and adjust VERNIER 11 to obtain the exact pulse width.
- e) Set the AMPLITUDE switches 3 and 4 to the required ranges and adjust VERNIER 8 and 9 to obtain the exact amplitude.
- f) If required, switch the OFFSET switches 13 and 14 to ON and adjust VERNIER 12 and 15 to the desired dc offset level.

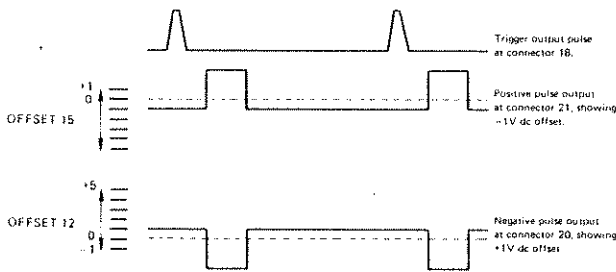

Figure 3-2. Examples of internally triggered waveforms.

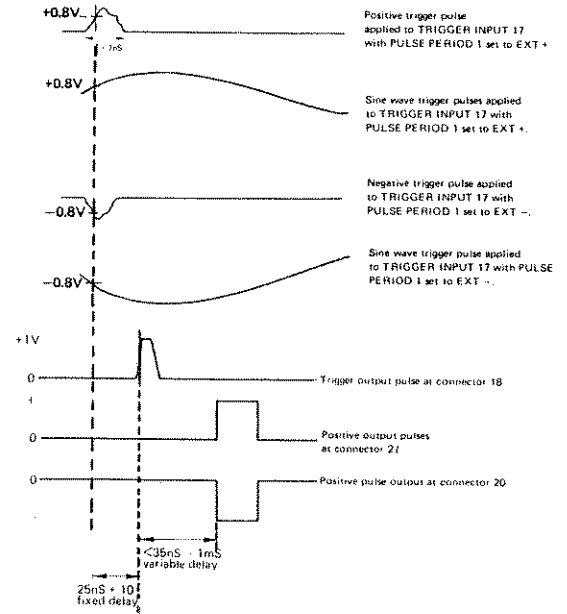

Figure 3-3. Examples of externally triggered waveforms.

3-9 External Trigger

3-10 Use the following procedure to obtain an output similar to that shown in Figure 3-3

- a) Set the Mode Selector 22 to NORM
- b) Apply suitable trigger pulses to the TRIGGER INPUT socket 17.
- c) Set the PULSE PERIOD switch 1 to EXT + for positive, or to EXT - for negative, input pulses.
- d) Set the delay between the Trigger and output pulses as required (refer to paragraph 3-8).
- e) Set the pulse width, amplitude and offset as required (refer to paragraph 3-8).

3-11 Manual

3-12 Use the following procedure to obtain an output similar to that shown in Figure 3-4.

- a) Set the Mode Selector 22 to NORM.
- b) Set the PULSE PERIOD switch 1 to either EXT + or EXT -.
- c) Set the delay between the trigger and the output pulse as described in paragraph 3-8.
- d) Set the pulse width, amplitude and offset as required (refer to paragraph 3-8).
- e) Press the MAN button 5 once for each output pulse required.

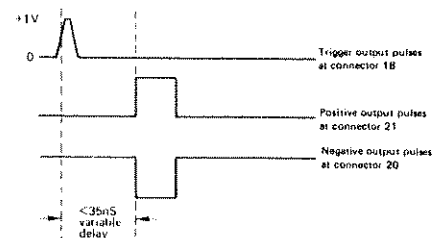

Figure 3-4. Output waveforms for manual operation.

3-13 Square Wave

3-14 Use the following procedure to obtain an output similar to that shown in Figure 3-5.

- Set the Mode Selector 22 to NORM.
- Set the PULSE PERIOD switch 1 to an internal range as described in paragraph 3-8 or set EXT as described in paragraph 3-9 and apply external trigger pulses in order to set the repetition rate of the output pulses.
- Set the PULSE WIDTH switch 10 to SQUARE WAVE.
- Set the amplitude and offset as required (refer to paragraph 3-8).

Note that, the square wave output cannot be gated.

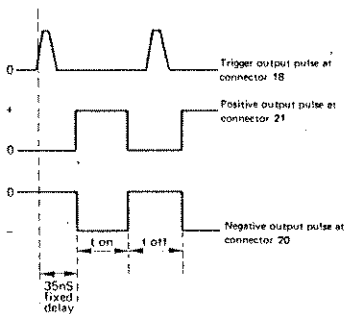

Figure 3-5. Examples of square wave output pulses.

3-15 Gating

3-16 The trigger and output pulses obtained in the normal mode may be gated (except in square wave mode) by applying a suitable gate pulse to the GATE INPUT socket 19. In the gated operation only the repetition rate generator is affected and, therefore, all output pulse parameters are controlled in the same manner as for internal trigger as described in paragraph 3-8. Figure 3-6 illustrates samples of output obtainable when the pulse generator is gated by an external signal.

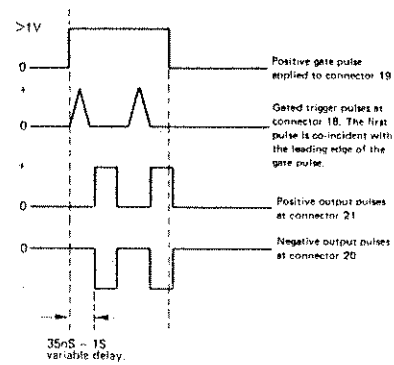

Figure 3-6. Examples of gated output waveforms.

3-17 RZ MODE

3-18 External pulses applied to the INPUT socket 23 (rear panel) trigger the delay generator directly and thus the shape of the output pulses is determined by the delay generator and the pulse-forming circuits that follow. The pulse output in this mode cannot be gated. Note that, although the repetition rate generator is on, it does not drive the pulse generator in this mode; thus, an internally generated trigger (independent of the OUTPUT at connectors 20 and 21) is available at the TRIGGER OUTPUT connector 18. To avoid interference between the internal repetition rate and the external signals when the TRIGGER OUTPUT 18 is not required, it is advisable to set the PULSE PERIOD switch 1 to EXT +. Square wave output is not available in the mode.

Use the following procedure to obtain an output similar to that shown in Figure 3-7.

- Set the Mode Selector 22 to RZ.
- Set the PULSE DELAY switch 6 to the desired range and adjust VERNIER 7. The output pulses will be delayed with respect to the external signal.
- Set the PULSE WIDTH switch 10 to the required range and adjust VERNIER 11 for exact pulse width.
- Set the amplitude and offset as required (refer to paragraph 3-7).

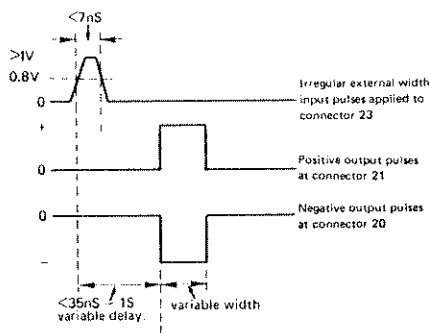

Figure 3-7. Examples of RZ Mode waveforms.

3-19 EXTERNAL WIDTH MODE

3-20 In this mode the output pulse width and pulse period is determined by the width of the input signal and the output pulses cannot be gated. Note that, although the repetition rate generator is on, it does not drive the pulse generator in this mode; thus, an internally generated trigger (independent of the OUTPUTS at connectors 20 and 21) is available at the TRIGGER

OUTPUT connector 18. To avoid interference between the internal repetition rate and the external signals when the TRIGGER OUTPUT 18 is not required, it is advisable to set the PULSE PERIOD switch 1 to EXT +. Square wave output is not available in this mode.

Use the following procedure to obtain an output similar to that shown in Figure 3-8.

- a) Set the Mode Selector 22 to EXT WIDTH.
- b) Set the amplitude and offset as required (refer to paragraph 3-7).

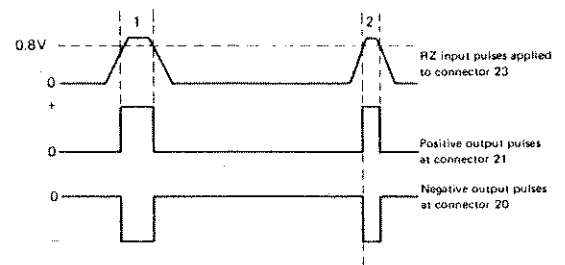

Figure 3-8. Comparison of input and output pulse widths.

SECTION IV MAINTENANCE

4-1 INTRODUCTION

4-2 The following information is presented in this section:

- a) Testing, troubleshooting and adjustment
- b) Removal and replacement of cover and assemblies.

4-3 TESTING, TROUBLESHOOTING AND ADJUSTMENT

4-4 The tests have been arranged into three groups (preliminary checks, performance tests, and internal checks and adjustments) so that:

- a) The instrument covers need not be removed unless repair or adjustment is required.
- b. An indication of the general serviceability of the pulse generator is obtained at an early stage by the preliminary checks. In this way the bulk of troubleshooting and repair may be done before the performance tests are commenced.

A possible way in which testing and troubleshooting may be organised will now be described; a flow-charted procedure is used which will locate faults to an assembly and sometimes to a circuit within an assembly. Troubleshooting down to component level (once the faulty assembly or circuit is identified) will depend on standard techniques using the appropriate circuit diagram.

4-5 Organisation (Figure 4-1)

4-6 The instrument is prepared for use and the switching procedure completed. The preliminary checks (Tables 4-2 to 4-8) are then performed and, if these are satisfactory, the performance tests (Tables 4-9 to 4-23) are carried out. Satisfactory completion of the performance tests will establish that the instrument reaches the specification. Execute a table in the order in which it is written. Note that, only the tests for OUTPUT 21 are described; when it is necessary to check the OUTPUT 20 (as indicated by a broken-line connection), repeat the table—substituting the appropriate controls where different from those used for OUTPUT 20.

4-7 If the preliminary checks are not satisfactory, the troubleshooting charts in Figures 5-4 to 5-9 should be performed. At this point it is recommended that the internal checks and adjustments (Tables 4-24 to 4-27) be performed before attempting to repair the fault as diagnosed by means of the flowcharts — in this way, the possibilities of failure due to the power supply, the timing or output circuits are eliminated.

4-8 When the internal checks and adjustments, and any repairs deemed necessary while the troubleshooting procedure was carried out, have been satisfactorily completed, proceed with the performance test.

4-9 Test Equipment

4-10 A list of the test equipment and accessories required appears in Table 4-1.

4-11 Troubleshooting Charts.

4-12 The waveforms shown on the troubleshooting charts are those which should be obtained with the given control settings and these should be compared with those actually obtained. All the waveforms are shown on the Normal Mode flowchart but only the waveforms which differ from the normal are shown on the subsequent flowcharts.

4-13 REMOVAL AND REPLACEMENT OF COVERS AND ASSEMBLIES

4-14 Access to Test Points and Assemblies

4-15 To gain access to all test points and assemblies remove the top and bottom covers after first removing their fastening screws.

4-16 Removal of Assemblies (Figure 5-3)

4-17 Assembly 1 is removed as follows:

- a. Disconnect coaxial cable and wire (0-4).
- b. Remove three securing screws.
- c. Unplug from connector XA1 on A3.

Assembly 2 is removed as follows:

- a. Disconnect wire (0-4).

- b. Remove three securing screws
- c. Unplug from connector XA2 on A3.

- out of frame.
- d. Remove six securing screws.

Assembly 3 is removed as follows:

- a. Remove assemblies 1 and 2.
- b. Remove all cables and wires.
- c. Push on A3 until front panel moves

Assembly 4 is removed as follows:

- a. Remove four securing screws (at rear panel).
- b. Disconnect all wires.

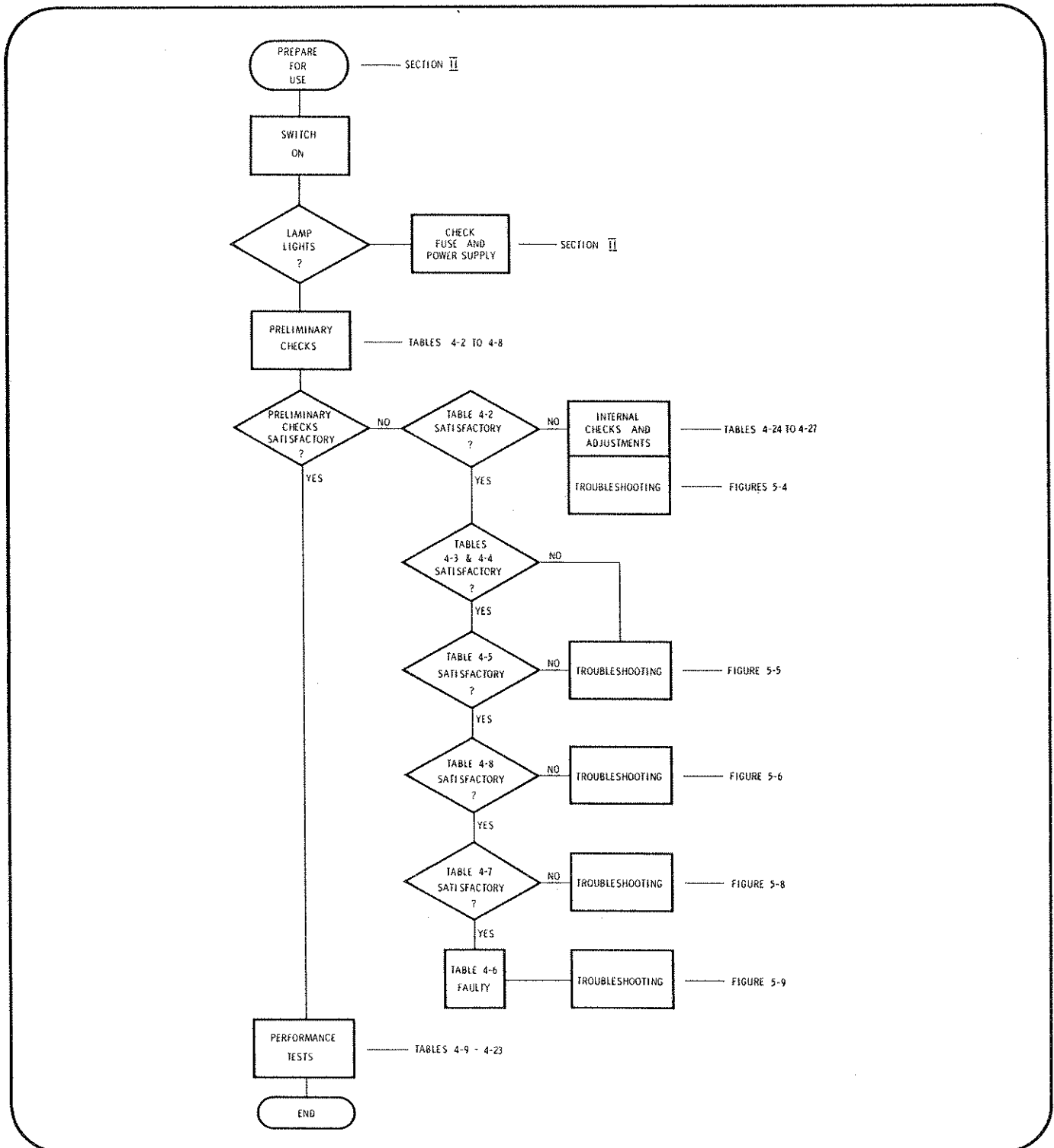

Figure 4-1 Organization of Tests and Troubleshooting

Table 4-1. Test Equipment and Accessories

INSTRUMENT	BRIEF SPECIFICATION	RECOMMENDED MODEL
Counter	Frequency range 0 – 50 MHz	HP 5245L
Oscilloscope	Dual-channel, 50 MHz bandwidth	HP 180A with plug-ins 1801A, 1821A
Digital Voltmeter	10V dc range to 4 significant figures. Accuracy $\pm 0.05\% \pm 1$ digit.	HP 3440A with plug-in 3444A.
Sampling Oscilloscope	Dual-channel, 1 GHz bandwidth	HP 140A with plug-ins 1410A, 1424A
AC Voltmeter	Sensitivity 100 μ V to 300V rms.	HP 403B
Voltmeter Ammeter Ohmmeter	1mV to 1000V FSD. $\pm 1\%$ of FSD. 1 μ A to 1A FSD. $\pm 2\%$ of FSD. 1ohm to 100 Mohm $\pm 5\%$ at center scale	HP 412A
Test Oscillator	Frequency range 10 Hz – 10 MHz	HP 651A
Test Oscillator	Frequency range 10 to 500 MHz	HP3200B
Pulse Generator	Frequency range 100 MHz with variable rise and falltime capability.	HP 8007A







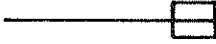

ACCESSORIES	SYMBOLS USED IN THIS SECTION	RECOMMENDED MODEL
50 cable assembly with male BNC connectors (6 required).		HP 10120A
50 Termination, type GR (2 required)		GR 874 – W50B
10:1 Divider Probe		HP 10214A
50 Tee Connector (2 required)		HP 10221A
10:1 Voltage Divider Probe		HP 10004B
50 Feed-through termination		HP 11048B UG-274/u 74868
Cable Assembly (2 required)		HP 1100A
Pulse Adder		HP 15104A
20 dB Attenuator, 50 (2 required)		HP 8491A

Table 4-2. Preliminary Check: Internal Operation.

TEST SET-UP

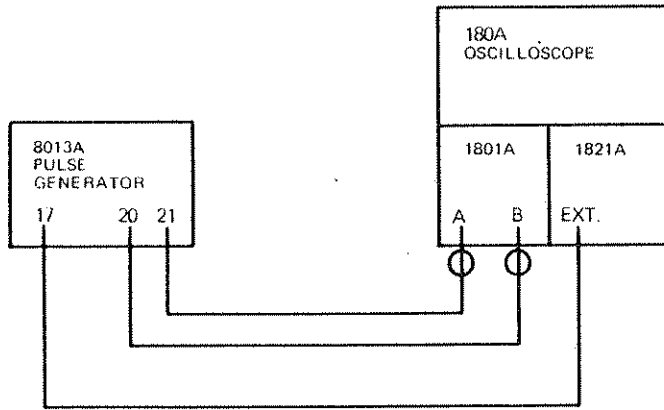

STEP

INSTRUCTIONS

RESULTS

1

Set the 8013A controls as follows:

PULSE PERIOD 1	1 μ – .1m
VERNIER 2	CW
PULSE DELAY 6	1 μ – .1m
VERNIER 7	CCW
PULSE WIDTH 10	1 μ – .1m
VERNIER 11	Mid-range
AMPLITUDE 3	5.0 – 2.0
VERNIER 8	CW
AMPLITUDE 4	5.0 – 2.0
VERNIER 9	CW
OFFSET 13	ON
VERNIER 12	Mid-range
OFFSET 14	ON
VERNIER 15	Mid-range
Mode selector 22	NORM

2

With reference to the diagram below, check the function of the pulse generator and compare the output from both channels.

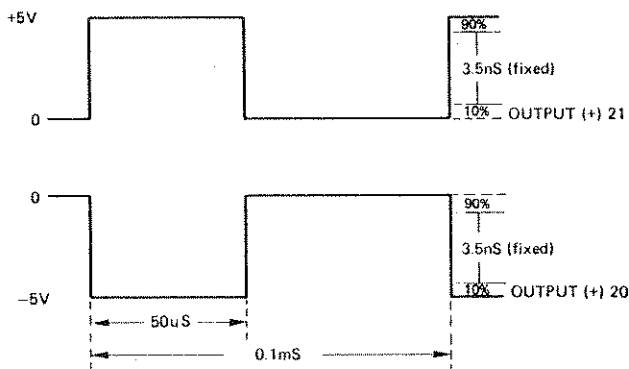
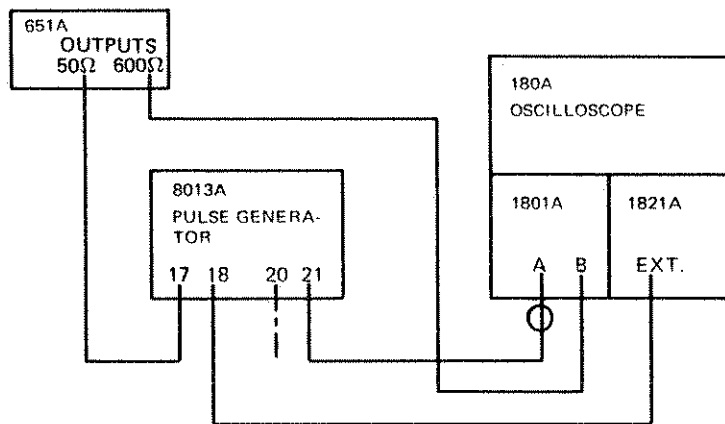

Table 4-3. Preliminary Check: External Trigger Operation

TEST SET-UP



STEP	INSTRUCTIONS	RESULTS																								
1	<p>Set the 8013A controls as follows:</p> <table border="0"> <tr> <td>PULSE PERIOD 1</td> <td>EXT (+)</td> </tr> <tr> <td>PULSE DELAY 6</td> <td>35n – 1u</td> </tr> <tr> <td>VERNIER 7</td> <td>CW</td> </tr> <tr> <td>PULSE WIDTH 10</td> <td>10n – 1u</td> </tr> <tr> <td>VERNIER 11</td> <td>CCW</td> </tr> <tr> <td>AMPLITUDE 3</td> <td>5.0 – 2.0</td> </tr> <tr> <td>VERNIER 8</td> <td>CW</td> </tr> <tr> <td>AMPLITUDE 4</td> <td>5.0 – 2.0</td> </tr> <tr> <td>VERNIER 9</td> <td>CW</td> </tr> <tr> <td>OFFSET 13</td> <td>OFF</td> </tr> <tr> <td>OFFSET 14</td> <td>OFF</td> </tr> <tr> <td>Mode selector 22</td> <td>NORM</td> </tr> </table>	PULSE PERIOD 1	EXT (+)	PULSE DELAY 6	35n – 1u	VERNIER 7	CW	PULSE WIDTH 10	10n – 1u	VERNIER 11	CCW	AMPLITUDE 3	5.0 – 2.0	VERNIER 8	CW	AMPLITUDE 4	5.0 – 2.0	VERNIER 9	CW	OFFSET 13	OFF	OFFSET 14	OFF	Mode selector 22	NORM	
PULSE PERIOD 1	EXT (+)																									
PULSE DELAY 6	35n – 1u																									
VERNIER 7	CW																									
PULSE WIDTH 10	10n – 1u																									
VERNIER 11	CCW																									
AMPLITUDE 3	5.0 – 2.0																									
VERNIER 8	CW																									
AMPLITUDE 4	5.0 – 2.0																									
VERNIER 9	CW																									
OFFSET 13	OFF																									
OFFSET 14	OFF																									
Mode selector 22	NORM																									
2	<p>Set the 651A controls as follows:</p> <table border="0"> <tr> <td>Range</td> <td>X10</td> </tr> <tr> <td>Vernier</td> <td>2.5</td> </tr> <tr> <td>Attenuator</td> <td>+10 dB (1.0V)</td> </tr> </table>	Range	X10	Vernier	2.5	Attenuator	+10 dB (1.0V)																			
Range	X10																									
Vernier	2.5																									
Attenuator	+10 dB (1.0V)																									
3	Center with vertical channels on the oscilloscope and observe the waveforms. The leading edge of the output pulse shall occur during positive slope of the sinewave.																									
4	Set PULSE PERIOD 1 EXT (–): the leading edge of the output pulse shall occur during the negative slope of the sinewave.																									

Table 4-4. Preliminary Check: High Frequency Trigger Operation

TEST SET-UP

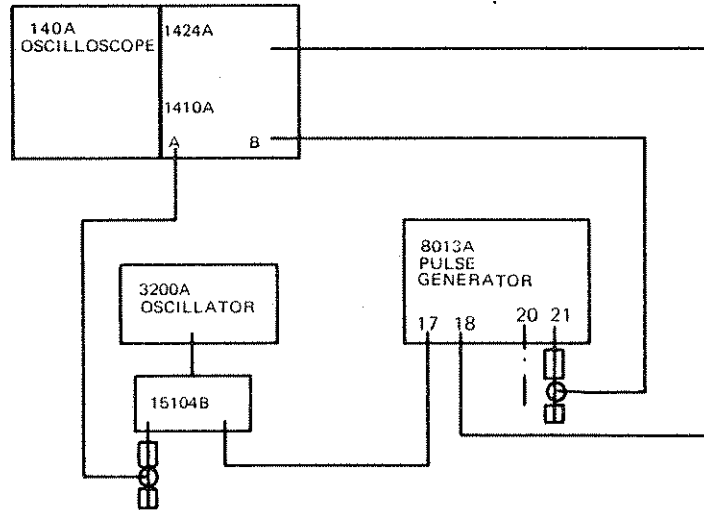

STEP	INSTRUCTIONS	RESULTS																						
1	Set the 8013A controls as follows:																							
	<table border="0"> <tr> <td>PULSE PERIOD 1</td> <td>EXT (+)</td> </tr> <tr> <td>PULSE DELAY 6</td> <td>35n - 1u</td> </tr> <tr> <td>VERNIER 7</td> <td>CCW</td> </tr> <tr> <td>PULSE WIDTH 10</td> <td>10n - 1u</td> </tr> <tr> <td>VERNIER 11</td> <td>CCW</td> </tr> <tr> <td>AMPLITUDE 3</td> <td>5.0 - 2.0</td> </tr> <tr> <td>VERNIER 8</td> <td>CW</td> </tr> <tr> <td>AMPLITUDE 4</td> <td>5.0 - 2.0</td> </tr> <tr> <td>VERNIER 9</td> <td>CW</td> </tr> <tr> <td>OFFSET 13</td> <td>OFF</td> </tr> <tr> <td>OFFSET 14</td> <td>OFF</td> </tr> </table>	PULSE PERIOD 1	EXT (+)	PULSE DELAY 6	35n - 1u	VERNIER 7	CCW	PULSE WIDTH 10	10n - 1u	VERNIER 11	CCW	AMPLITUDE 3	5.0 - 2.0	VERNIER 8	CW	AMPLITUDE 4	5.0 - 2.0	VERNIER 9	CW	OFFSET 13	OFF	OFFSET 14	OFF	
PULSE PERIOD 1	EXT (+)																							
PULSE DELAY 6	35n - 1u																							
VERNIER 7	CCW																							
PULSE WIDTH 10	10n - 1u																							
VERNIER 11	CCW																							
AMPLITUDE 3	5.0 - 2.0																							
VERNIER 8	CW																							
AMPLITUDE 4	5.0 - 2.0																							
VERNIER 9	CW																							
OFFSET 13	OFF																							
OFFSET 14	OFF																							
2	Mode selector 22 NORM																							
	Apply a sinewave with a repetition rate of 50 MHz and amplitude of 1.5V pp. Check repetition rate of output is equal repetition rate of input i.e. 50 MHz.																							
3	Set PULSE PERIOD 1 to EXT (-).																							
4	Repeat step 2.																							

Table 4-5. Preliminary Check: Manual Operation.

TEST SET-UP

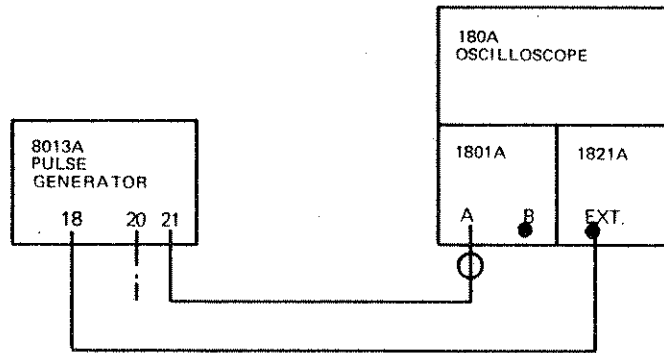

STEP	INSTRUCTIONS	RESULTS
1	PULSE PERIOD 1 PULSE DELAY 6 VERNIER 7 PULSE WIDTH 10 VERNIER 11 AMPLITUDE 3 VERNIER 8 AMPLITUDE 4 VERNIER 9 OFFSET 13 OFFSET 14 Mode selector 22	EXT (+) 35n - 1u CCW 1u - .1m CW 5.0 - 2.0 CW 5.0 - 2.0 CW OFF OFF NORM
2	Press MAN button 5. Only one output pulse must occur when the button is pressed, no pulse must occur when the button is released.	

Table 4-6. Preliminary Check: External Width Operation.

TEST SET-UP

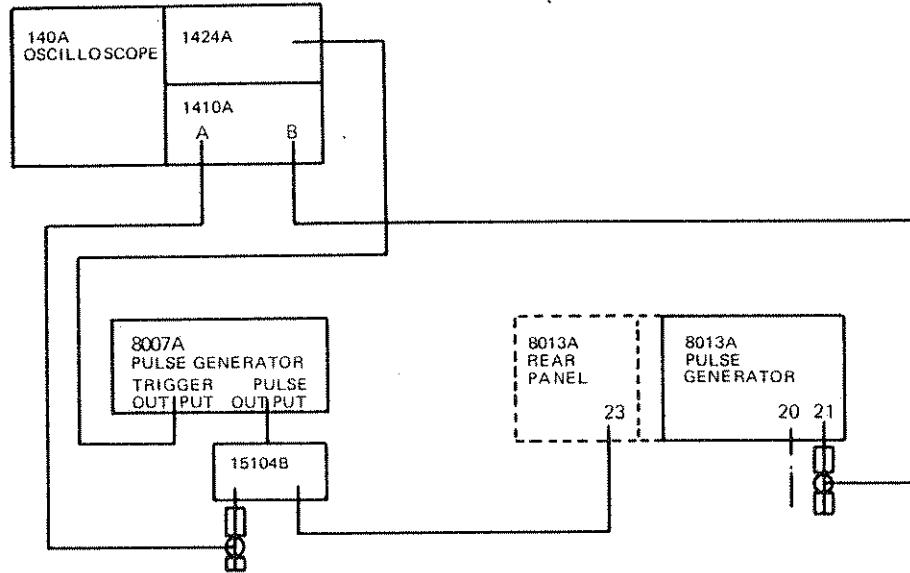

STEP	INSTRUCTIONS	RESULT																
1	<p>Set the 8013A controls as follows:</p> <table border="0"> <tr> <td>PULSE PERIOD 1</td> <td>EXT +</td> </tr> <tr> <td>AMPLITUDE 3</td> <td>5.0 - 2.0</td> </tr> <tr> <td>VERNIER 8</td> <td>CCW</td> </tr> <tr> <td>AMPLITUDE 4</td> <td>5.0 - 2.0</td> </tr> <tr> <td>VERNIER 9</td> <td>CCW</td> </tr> <tr> <td>OFFSET 13</td> <td>OFF</td> </tr> <tr> <td>OFFSET 14</td> <td>OFF</td> </tr> <tr> <td>Mode selector 22</td> <td>EXT. WIDTH</td> </tr> </table>	PULSE PERIOD 1	EXT +	AMPLITUDE 3	5.0 - 2.0	VERNIER 8	CCW	AMPLITUDE 4	5.0 - 2.0	VERNIER 9	CCW	OFFSET 13	OFF	OFFSET 14	OFF	Mode selector 22	EXT. WIDTH	
PULSE PERIOD 1	EXT +																	
AMPLITUDE 3	5.0 - 2.0																	
VERNIER 8	CCW																	
AMPLITUDE 4	5.0 - 2.0																	
VERNIER 9	CCW																	
OFFSET 13	OFF																	
OFFSET 14	OFF																	
Mode selector 22	EXT. WIDTH																	
2	Apply external signals to INPUT 23																	
3	Note that, the leading and trailing edge of the output pulse is coincident with the leading and trailing edges of the input pulse. The output pulse width will be that of the input pulse at the switching level of 1V.																	

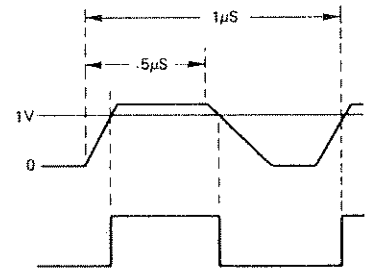
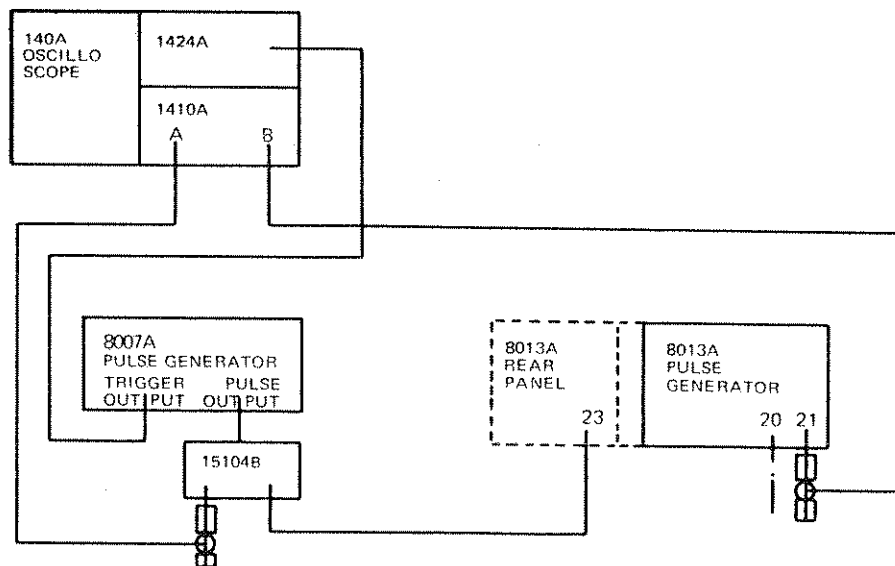

Table 4-7. Preliminary Check: RZ Operation

TEST SET-UP



STEP	INSTRUCTIONS	RESULT																								
1	<p>Set the 8013A controls as follows:</p> <table border="0"> <tr> <td>PULSE PERIOD 1</td> <td>EXT+</td> </tr> <tr> <td>PULSE DELAY 6</td> <td>35n - 1u</td> </tr> <tr> <td>VERNIER 7</td> <td>CCW</td> </tr> <tr> <td>PULSE WIDTH 10</td> <td>10n - 1u</td> </tr> <tr> <td>VERNIER 11</td> <td>CCW</td> </tr> <tr> <td>AMPLITUDE 3</td> <td>5.0 - 2.0</td> </tr> <tr> <td>VERNIER 8</td> <td>CCW</td> </tr> <tr> <td>AMPLITUDE 4</td> <td>5.0 - 2.0</td> </tr> <tr> <td>VERNIER 9</td> <td>CCW</td> </tr> <tr> <td>OFFSET 13</td> <td>OFF</td> </tr> <tr> <td>OFFSET 14</td> <td>OFF</td> </tr> <tr> <td>Mode selector 22</td> <td>RZ</td> </tr> </table>	PULSE PERIOD 1	EXT+	PULSE DELAY 6	35n - 1u	VERNIER 7	CCW	PULSE WIDTH 10	10n - 1u	VERNIER 11	CCW	AMPLITUDE 3	5.0 - 2.0	VERNIER 8	CCW	AMPLITUDE 4	5.0 - 2.0	VERNIER 9	CCW	OFFSET 13	OFF	OFFSET 14	OFF	Mode selector 22	RZ	
PULSE PERIOD 1	EXT+																									
PULSE DELAY 6	35n - 1u																									
VERNIER 7	CCW																									
PULSE WIDTH 10	10n - 1u																									
VERNIER 11	CCW																									
AMPLITUDE 3	5.0 - 2.0																									
VERNIER 8	CCW																									
AMPLITUDE 4	5.0 - 2.0																									
VERNIER 9	CCW																									
OFFSET 13	OFF																									
OFFSET 14	OFF																									
Mode selector 22	RZ																									
2	With reference to the diagram, apply an external signal to the INPUT connector 23 and observe the pulse output.																									

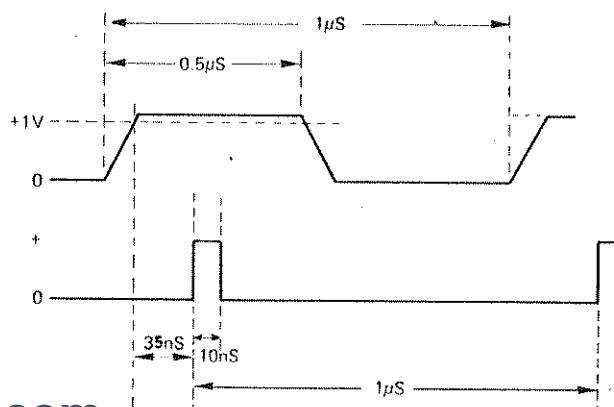
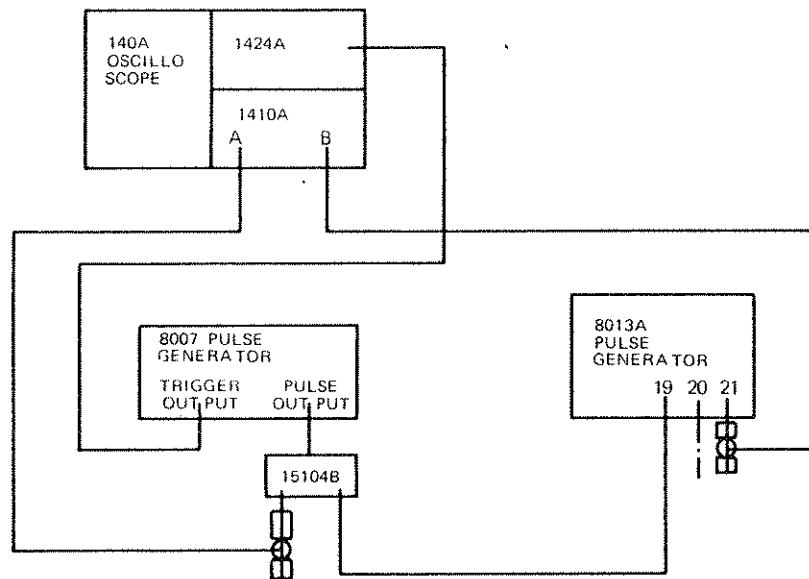

Table 4-8. Preliminary Check: Gate Operation.

TEST SET-UP



STEP	INSTRUCTIONS	RESULTS
1	PULSE PERIOD 1 20n – 1u VERNIER 2 CCW PULSE DELAY 6 35n – 1u VERNIER 7 CCW PULSE WIDTH 10 10n – 1u VERNIER 11 CCW AMPLITUDE 3 5.0 – 2.0 VERNIER 8 CCW AMPLITUDE 4 5.0 – 2.0 VERNIER 9 CCW OFFSET 13 OFF OFFSET 14 OFF Mode selector 22 NORM	
2	Apply gate pulse to GATE INPUT 19.	
3	Check that output pulses only occur during on time of gate pulse: Turn pulse period VERNIER 2 slowly CW and check gate operation for all pulse periods.	
4	Check that leading edge of first trigger output pulse (TRIGGER OUTPUT 18) coincides with leading edge of gate pulse and that trigger pulses occur only during on time of gate pulse.	
5	Check that last pulse width is correct even though gate pulse trailing edge appears during last pulse:	

Table 4-9. Performance Test: Preshoot, Overshoot and Ringing

TEST SET-UP

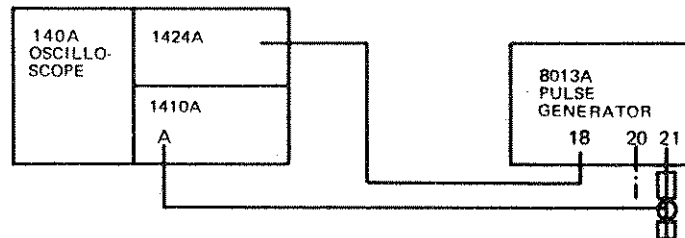

STEP	INSTRUCTIONS	RESULTS																										
1	<p>Set the 8013A controls as follows:</p> <table border="0"> <tr> <td>PULSE PERIOD 1</td> <td>20n - 1u</td> </tr> <tr> <td>VERNIER 2</td> <td>CCW</td> </tr> <tr> <td>PULSE DELAY 6</td> <td>35n - 1u</td> </tr> <tr> <td>VERNIER 7</td> <td>CCW</td> </tr> <tr> <td>PULSE WIDTH 10</td> <td>SQUARE WAVE</td> </tr> <tr> <td>VERNIER 11</td> <td>CW</td> </tr> <tr> <td>AMPLITUDE 3</td> <td>5.0 - 2.0</td> </tr> <tr> <td>VERNIER 8</td> <td>CW</td> </tr> <tr> <td>AMPLITUDE 4</td> <td>5.0 - 2.0</td> </tr> <tr> <td>VERNIER 9</td> <td>CW</td> </tr> <tr> <td>OFFSET 13</td> <td>OFF</td> </tr> <tr> <td>OFFSET 14</td> <td>OFF</td> </tr> <tr> <td>Mode selector 22</td> <td>NORM</td> </tr> </table>	PULSE PERIOD 1	20n - 1u	VERNIER 2	CCW	PULSE DELAY 6	35n - 1u	VERNIER 7	CCW	PULSE WIDTH 10	SQUARE WAVE	VERNIER 11	CW	AMPLITUDE 3	5.0 - 2.0	VERNIER 8	CW	AMPLITUDE 4	5.0 - 2.0	VERNIER 9	CW	OFFSET 13	OFF	OFFSET 14	OFF	Mode selector 22	NORM	
PULSE PERIOD 1	20n - 1u																											
VERNIER 2	CCW																											
PULSE DELAY 6	35n - 1u																											
VERNIER 7	CCW																											
PULSE WIDTH 10	SQUARE WAVE																											
VERNIER 11	CW																											
AMPLITUDE 3	5.0 - 2.0																											
VERNIER 8	CW																											
AMPLITUDE 4	5.0 - 2.0																											
VERNIER 9	CW																											
OFFSET 13	OFF																											
OFFSET 14	OFF																											
Mode selector 22	NORM																											
2	<p>With reference to the diagram below, measure preshoot, overshoot and ringing in turn to ensure that these are $< \pm 5\%$ of the pulse amplitude.</p>																											

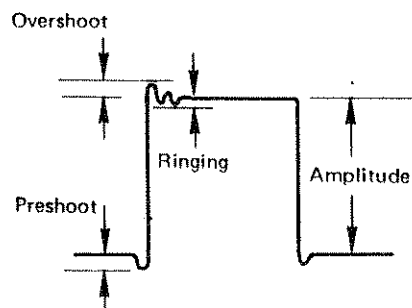
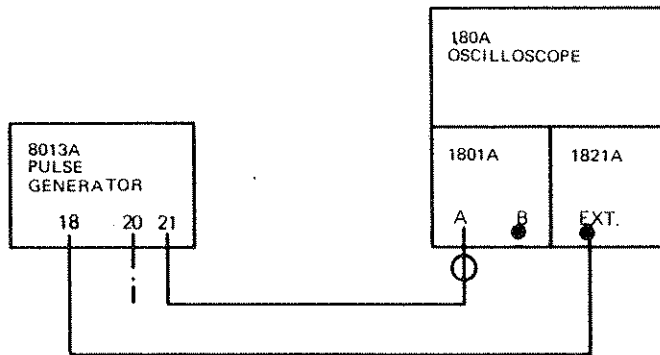

Table 4-12. Performance Test: Pulse Delay

TEST SET-UP



STEP	INSTRUCTIONS	RESULTS
------	--------------	---------

1	Set 8013A controls as follows: <table border="0" style="margin-left: 20px; width: 80%;"> <tr><td>PULSE PERIOD 1</td><td>1u – .1m</td></tr> <tr><td>VERNIER 2</td><td>CW</td></tr> <tr><td>PULSE DELAY 6</td><td>35n – 1u</td></tr> <tr><td>VERNIER 7</td><td>CW</td></tr> <tr><td>PULSE WIDTH 10</td><td>10n – 1u</td></tr> <tr><td>VERNIER 11</td><td>CW</td></tr> <tr><td>AMPLITUDE 3</td><td>5.0 – 2.0</td></tr> <tr><td>VERNIER 8</td><td>CW</td></tr> <tr><td>AMPLITUDE 4</td><td>5.0 – 2.0</td></tr> <tr><td>VERNIER 9</td><td>CW</td></tr> <tr><td>OFFSET 13</td><td>OFF</td></tr> <tr><td>OFFSET 14</td><td>OFF</td></tr> <tr><td>Mode selector 22</td><td>NORM</td></tr> </table>	PULSE PERIOD 1	1u – .1m	VERNIER 2	CW	PULSE DELAY 6	35n – 1u	VERNIER 7	CW	PULSE WIDTH 10	10n – 1u	VERNIER 11	CW	AMPLITUDE 3	5.0 – 2.0	VERNIER 8	CW	AMPLITUDE 4	5.0 – 2.0	VERNIER 9	CW	OFFSET 13	OFF	OFFSET 14	OFF	Mode selector 22	NORM	
PULSE PERIOD 1	1u – .1m																											
VERNIER 2	CW																											
PULSE DELAY 6	35n – 1u																											
VERNIER 7	CW																											
PULSE WIDTH 10	10n – 1u																											
VERNIER 11	CW																											
AMPLITUDE 3	5.0 – 2.0																											
VERNIER 8	CW																											
AMPLITUDE 4	5.0 – 2.0																											
VERNIER 9	CW																											
OFFSET 13	OFF																											
OFFSET 14	OFF																											
Mode selector 22	NORM																											

2	Check the pulse delay for both VERNIER 7 extremities of each range setting of the PULSE DELAY selector 6 as follows:	
---	--	--

PULSE DELAY 6	VERNIER 7	PULSE PERIOD 1	PULSE WIDTH 10	
35n – 1u	CW	1u – .1m	10n – 1u	> 1uS
1u – .1m	CW	.1m – 10m	1u – .1m	> 100uS
1u – .1m	CCW	10n – .1m	1u – .1m	< 1uS
.1m – 10m	CW	10m – 1	.1m – 10m	> 10us
.1m – 10m	CCW	.1m – 10m	.1u – .1m	< 100uS
10m – 1m	CW	EXT+(press MAN)	10m – 1	> 1S
10m – 1m	CCW	10m – 1m	.1m – 10m	< 10mS

Table 4-13. Performance Test: Pulse Delay Jitter.

TEST SET-UP

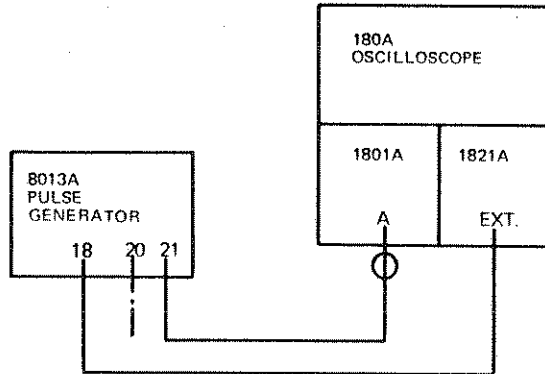

STEP	INSTRUCTIONS	RESULTS
1	Set the 8013A controls as follows: PULSE PERIOD 1 .1m – 10m VERNIER 2 CW PULSE DELAY 6 1u – .1m VERNIER 7 CW PULSE WIDTH 10 1u – .1m VERNIER 11 CCW AMPLITUDE 3 5.0 – 2.0 VERNIER 8 CW AMPLITUDE 4 5.0 – 2.0 VERNIER 9 CW OFFSET 13 OFF OFFSET 14 OFF Mode selector 22 NORM	
2	Adjust pulse period VERNIER 2 to obtain 0.4mS pulse period on display.	
3	Adjust pulse delay VERNIER 7 to obtain 0.1mS pulse delay.	
4	Adjust 1821A Delay (Div) vernier until intensified spot coincides with leading edge of first pulse.	
5	Switch Mode switch on 1821A to MIXED.	
6	Measure the pulse delay jitter	< .1 %

Table 4-10. Performance Test: Pulse Period

TEST SET-UP

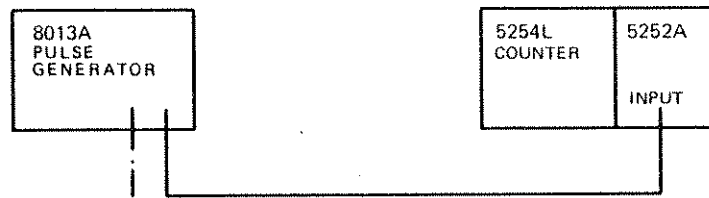

STEP	INSTRUCTIONS	RESULTS																																				
1	<p>Set the 8013A controls as follows:</p> <table border="0"> <tr> <td>PULSE PERIOD 1</td> <td>20n – 1u</td> </tr> <tr> <td>VERNIER 2</td> <td>CCW</td> </tr> <tr> <td>PULSE DELAY 6</td> <td>35n – 1u</td> </tr> <tr> <td>VERNIER 7</td> <td>CCW</td> </tr> <tr> <td>PULSE WIDTH 10</td> <td>10n – 1u</td> </tr> <tr> <td>VERNIER 11</td> <td>CCW</td> </tr> <tr> <td>AMPLITUDE 3</td> <td>5.0 – 2.0</td> </tr> <tr> <td>VERNIER 8</td> <td>CW</td> </tr> <tr> <td>AMPLITUDE 4</td> <td>5.0 – 2.0</td> </tr> <tr> <td>VERNIER 9</td> <td>CW</td> </tr> <tr> <td>OFFSET 13</td> <td>OFF</td> </tr> <tr> <td>OFFSET 14</td> <td>OFF</td> </tr> <tr> <td>Mode selector 22</td> <td>NORM</td> </tr> </table>	PULSE PERIOD 1	20n – 1u	VERNIER 2	CCW	PULSE DELAY 6	35n – 1u	VERNIER 7	CCW	PULSE WIDTH 10	10n – 1u	VERNIER 11	CCW	AMPLITUDE 3	5.0 – 2.0	VERNIER 8	CW	AMPLITUDE 4	5.0 – 2.0	VERNIER 9	CW	OFFSET 13	OFF	OFFSET 14	OFF	Mode selector 22	NORM											
PULSE PERIOD 1	20n – 1u																																					
VERNIER 2	CCW																																					
PULSE DELAY 6	35n – 1u																																					
VERNIER 7	CCW																																					
PULSE WIDTH 10	10n – 1u																																					
VERNIER 11	CCW																																					
AMPLITUDE 3	5.0 – 2.0																																					
VERNIER 8	CW																																					
AMPLITUDE 4	5.0 – 2.0																																					
VERNIER 9	CW																																					
OFFSET 13	OFF																																					
OFFSET 14	OFF																																					
Mode selector 22	NORM																																					
2	<p>Check repetition rate for each set of control settings given in table:</p> <table border="0"> <thead> <tr> <th>PULSE PERIOD (1)</th> <th>VERNIER (2)</th> <th>PULSE PERIOD</th> <th>FREQUENCY</th> </tr> </thead> <tbody> <tr> <td>20n – 1u</td> <td>CCW</td> <td>< 20nS</td> <td>> 50 MHz</td> </tr> <tr> <td>20n – 1u</td> <td>CW</td> <td>> 1uS</td> <td>< 1 MHz</td> </tr> <tr> <td>1u – .1m</td> <td>CW</td> <td>> .1mS</td> <td>< 10 kHz</td> </tr> <tr> <td>1u – .1m</td> <td>CCW</td> <td>< 1uS</td> <td>> 1 MHz</td> </tr> <tr> <td>.1m – 10m</td> <td>CW</td> <td>>10mS</td> <td>< 100 Hz</td> </tr> <tr> <td>.1m – 10m</td> <td>CCW</td> <td>< .1mS</td> <td>> 10 kHz</td> </tr> <tr> <td>10m – 1</td> <td>CW</td> <td>> 1S</td> <td>< 1 Hz</td> </tr> <tr> <td>10m – 1</td> <td>CCW</td> <td><10mS</td> <td>> 100 Hz</td> </tr> </tbody> </table>	PULSE PERIOD (1)	VERNIER (2)	PULSE PERIOD	FREQUENCY	20n – 1u	CCW	< 20nS	> 50 MHz	20n – 1u	CW	> 1uS	< 1 MHz	1u – .1m	CW	> .1mS	< 10 kHz	1u – .1m	CCW	< 1uS	> 1 MHz	.1m – 10m	CW	>10mS	< 100 Hz	.1m – 10m	CCW	< .1mS	> 10 kHz	10m – 1	CW	> 1S	< 1 Hz	10m – 1	CCW	<10mS	> 100 Hz	
PULSE PERIOD (1)	VERNIER (2)	PULSE PERIOD	FREQUENCY																																			
20n – 1u	CCW	< 20nS	> 50 MHz																																			
20n – 1u	CW	> 1uS	< 1 MHz																																			
1u – .1m	CW	> .1mS	< 10 kHz																																			
1u – .1m	CCW	< 1uS	> 1 MHz																																			
.1m – 10m	CW	>10mS	< 100 Hz																																			
.1m – 10m	CCW	< .1mS	> 10 kHz																																			
10m – 1	CW	> 1S	< 1 Hz																																			
10m – 1	CCW	<10mS	> 100 Hz																																			

Table 4-11. Performance Test: Pulse Period Jitter.

TEST SET-UP

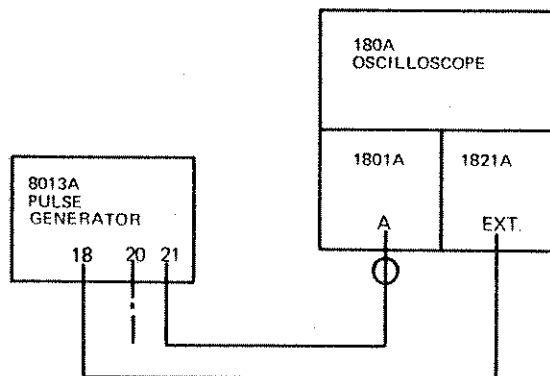

STEP	INSTRUCTIONS	RESULTS																								
1	<p>Set the 8012A controls as follows:</p> <table border="0"> <tr> <td>PULSE PERIOD 1</td> <td>1u - .1m</td> </tr> <tr> <td>PULSE DELAY 6</td> <td>35n - 1u</td> </tr> <tr> <td>VERNIER 7</td> <td>CCW</td> </tr> <tr> <td>PULSE WIDTH 10</td> <td>1u - .1m</td> </tr> <tr> <td>VERNIER 11</td> <td>CCW</td> </tr> <tr> <td>AMPLITUDE 3</td> <td>5.0 - 2.0</td> </tr> <tr> <td>VERNIER 8</td> <td>CW</td> </tr> <tr> <td>AMPLITUDE 4</td> <td>5.0 - 2.0</td> </tr> <tr> <td>VERNIER 9</td> <td>CW</td> </tr> <tr> <td>OFFSET 13</td> <td>OFF</td> </tr> <tr> <td>OFFSET 14</td> <td>OFF</td> </tr> <tr> <td>Mode selector 22</td> <td>NORM</td> </tr> </table>	PULSE PERIOD 1	1u - .1m	PULSE DELAY 6	35n - 1u	VERNIER 7	CCW	PULSE WIDTH 10	1u - .1m	VERNIER 11	CCW	AMPLITUDE 3	5.0 - 2.0	VERNIER 8	CW	AMPLITUDE 4	5.0 - 2.0	VERNIER 9	CW	OFFSET 13	OFF	OFFSET 14	OFF	Mode selector 22	NORM	
PULSE PERIOD 1	1u - .1m																									
PULSE DELAY 6	35n - 1u																									
VERNIER 7	CCW																									
PULSE WIDTH 10	1u - .1m																									
VERNIER 11	CCW																									
AMPLITUDE 3	5.0 - 2.0																									
VERNIER 8	CW																									
AMPLITUDE 4	5.0 - 2.0																									
VERNIER 9	CW																									
OFFSET 13	OFF																									
OFFSET 14	OFF																									
Mode selector 22	NORM																									
3	<p>Set the 1821A controls as follows:</p> <table border="0"> <tr> <td>Main Sweep</td> <td>0.1mS/div</td> </tr> <tr> <td>Delayed Sweep</td> <td>0.1uS/div</td> </tr> <tr> <td>Sweep Mode</td> <td>Norm.</td> </tr> <tr> <td>Delayed Trigger</td> <td>Auto.</td> </tr> <tr> <td>CM Delay</td> <td>2.0</td> </tr> </table>	Main Sweep	0.1mS/div	Delayed Sweep	0.1uS/div	Sweep Mode	Norm.	Delayed Trigger	Auto.	CM Delay	2.0															
Main Sweep	0.1mS/div																									
Delayed Sweep	0.1uS/div																									
Sweep Mode	Norm.																									
Delayed Trigger	Auto.																									
CM Delay	2.0																									
4	Adjust pulse period VERNIER 2 to obtain 0.1mS pulse period on display.																									
5	Adjust 1821A Delay (Div) vernier until intensified spot coincides with leading edge of second pulse on display.																									
6	Switch Mode switch on 1821A to MIXED.																									
7	Measure pulse period jitter:	<.1%																								

Table 4-14 Performance Test: Pulse Width (greater than 1uS).

TEST SET-UP

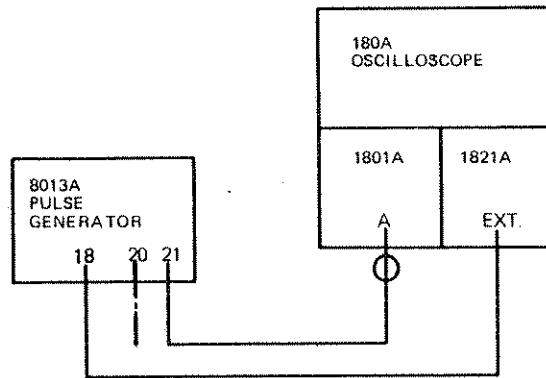

STEP	INSTRUCTIONS	RESULTS																																
1	<p>Set 8012A controls as follows:</p> <table border="0"> <tr> <td>PULSE PERIOD 1</td> <td>1u - .1m</td> </tr> <tr> <td>VERNIER 2</td> <td>CW</td> </tr> <tr> <td>PULSE DELAY 6</td> <td>35n - 1u</td> </tr> <tr> <td>VERNIER 7</td> <td>CCW</td> </tr> <tr> <td>PULSE WIDTH 10</td> <td>10n - 1u</td> </tr> <tr> <td>VERNIER 11</td> <td>CW</td> </tr> <tr> <td>AMPLITUDE 3</td> <td>5.0 - 2.0</td> </tr> <tr> <td>VERNIER 8</td> <td>CW</td> </tr> <tr> <td>AMPLITUDE 4</td> <td>5.0 - 2.0</td> </tr> <tr> <td>VERNIER 9</td> <td>CW</td> </tr> <tr> <td>OFFSET 13</td> <td>OFF</td> </tr> <tr> <td>OFFSET 14</td> <td>OFF</td> </tr> <tr> <td>Mode selector 22</td> <td>NORM</td> </tr> </table>	PULSE PERIOD 1	1u - .1m	VERNIER 2	CW	PULSE DELAY 6	35n - 1u	VERNIER 7	CCW	PULSE WIDTH 10	10n - 1u	VERNIER 11	CW	AMPLITUDE 3	5.0 - 2.0	VERNIER 8	CW	AMPLITUDE 4	5.0 - 2.0	VERNIER 9	CW	OFFSET 13	OFF	OFFSET 14	OFF	Mode selector 22	NORM							
PULSE PERIOD 1	1u - .1m																																	
VERNIER 2	CW																																	
PULSE DELAY 6	35n - 1u																																	
VERNIER 7	CCW																																	
PULSE WIDTH 10	10n - 1u																																	
VERNIER 11	CW																																	
AMPLITUDE 3	5.0 - 2.0																																	
VERNIER 8	CW																																	
AMPLITUDE 4	5.0 - 2.0																																	
VERNIER 9	CW																																	
OFFSET 13	OFF																																	
OFFSET 14	OFF																																	
Mode selector 22	NORM																																	
2	<p>Check the pulse width for both VERNIER 11 extremities of each range setting of the PULSE WIDTH selector 10 as follows:</p> <table border="0"> <thead> <tr> <th>PULSE WIDTH 10</th> <th>VERNIER 11</th> <th>PULSE PERIOD 1</th> <th>RESULTS</th> </tr> </thead> <tbody> <tr> <td>10n - 1u</td> <td>CW</td> <td>1u - .1m</td> <td>> 1uS</td> </tr> <tr> <td>1u - .1m</td> <td>CW</td> <td>.1m - 10m</td> <td>> .1mS</td> </tr> <tr> <td>1u - .1m</td> <td>CCW</td> <td>1u - .1m</td> <td>< 1uS</td> </tr> <tr> <td>.1m - 10m</td> <td>CW</td> <td>10m - 1</td> <td>> 10mS</td> </tr> <tr> <td>.1m - 10m</td> <td>CCW</td> <td>.1m - 10m</td> <td>< .1mS</td> </tr> <tr> <td>10m - 1</td> <td>CW</td> <td>EXT+ (Press MAN)</td> <td>> 1S</td> </tr> <tr> <td>10m - 1</td> <td>CCW</td> <td>10m - 1</td> <td>> 10mS</td> </tr> </tbody> </table>	PULSE WIDTH 10	VERNIER 11	PULSE PERIOD 1	RESULTS	10n - 1u	CW	1u - .1m	> 1uS	1u - .1m	CW	.1m - 10m	> .1mS	1u - .1m	CCW	1u - .1m	< 1uS	.1m - 10m	CW	10m - 1	> 10mS	.1m - 10m	CCW	.1m - 10m	< .1mS	10m - 1	CW	EXT+ (Press MAN)	> 1S	10m - 1	CCW	10m - 1	> 10mS	
PULSE WIDTH 10	VERNIER 11	PULSE PERIOD 1	RESULTS																															
10n - 1u	CW	1u - .1m	> 1uS																															
1u - .1m	CW	.1m - 10m	> .1mS																															
1u - .1m	CCW	1u - .1m	< 1uS																															
.1m - 10m	CW	10m - 1	> 10mS																															
.1m - 10m	CCW	.1m - 10m	< .1mS																															
10m - 1	CW	EXT+ (Press MAN)	> 1S																															
10m - 1	CCW	10m - 1	> 10mS																															

Table 4-15. Performance Test: Pulse Width (less than 10nS).

TEST SET-UP

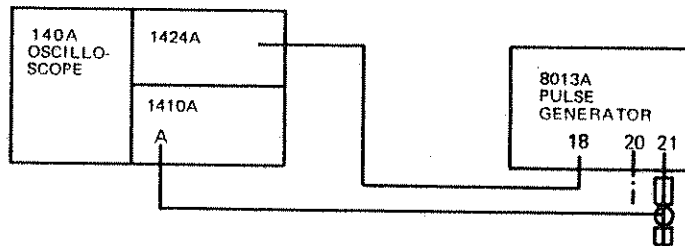

STEP	INSTRUCTIONS	RESULTS																										
1	Set the 8012A controls as follows:																											
	<table border="0"> <tr> <td>PULSE PERIOD 1</td> <td>20n – 1u</td> </tr> <tr> <td>VERNIER 2</td> <td>CCW</td> </tr> <tr> <td>PULSE DELAY 6</td> <td>35n – 1u</td> </tr> <tr> <td>VERNIER 7</td> <td>CCW</td> </tr> <tr> <td>PULSE WIDTH 10</td> <td>10n – 1u</td> </tr> <tr> <td>VERNIER 11</td> <td>CCW</td> </tr> <tr> <td>AMPLITUDE 3</td> <td>5.0 – 2.0</td> </tr> <tr> <td>VERNIER 8</td> <td>CW</td> </tr> <tr> <td>AMPLITUDE 4</td> <td>5.0 – 2.0</td> </tr> <tr> <td>VERNIER 9</td> <td>CW</td> </tr> <tr> <td>OFFSET 13</td> <td>OFF</td> </tr> <tr> <td>OFFSET 14</td> <td>OFF</td> </tr> <tr> <td>Mode selector 22</td> <td>NORM</td> </tr> </table>	PULSE PERIOD 1	20n – 1u	VERNIER 2	CCW	PULSE DELAY 6	35n – 1u	VERNIER 7	CCW	PULSE WIDTH 10	10n – 1u	VERNIER 11	CCW	AMPLITUDE 3	5.0 – 2.0	VERNIER 8	CW	AMPLITUDE 4	5.0 – 2.0	VERNIER 9	CW	OFFSET 13	OFF	OFFSET 14	OFF	Mode selector 22	NORM	
PULSE PERIOD 1	20n – 1u																											
VERNIER 2	CCW																											
PULSE DELAY 6	35n – 1u																											
VERNIER 7	CCW																											
PULSE WIDTH 10	10n – 1u																											
VERNIER 11	CCW																											
AMPLITUDE 3	5.0 – 2.0																											
VERNIER 8	CW																											
AMPLITUDE 4	5.0 – 2.0																											
VERNIER 9	CW																											
OFFSET 13	OFF																											
OFFSET 14	OFF																											
Mode selector 22	NORM																											
2	Measure the pulse width:	< 10nS																										

Table 4-16. Performance Test: Pulse Width Jitter.

TEST SET-UP

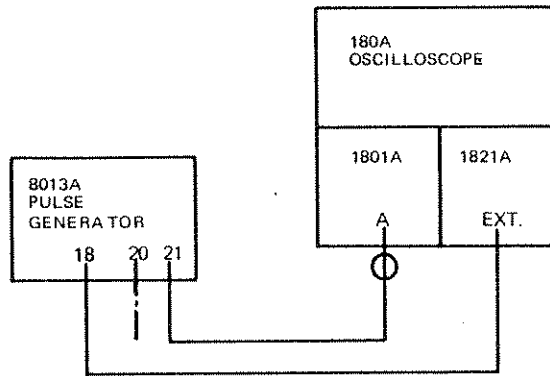

STEP	INSTRUCTIONS	RESULTS																										
1	Set the 8013A controls as follows:																											
	<table border="0"> <tr> <td>PULSE PERIOD 1</td> <td>.1m – 10m</td> </tr> <tr> <td>VERNIER 2</td> <td>CW</td> </tr> <tr> <td>PULSE DELAY 6</td> <td>35n – 1u</td> </tr> <tr> <td>VERNIER 7</td> <td>CCW</td> </tr> <tr> <td>PULSE WIDTH 10</td> <td>1u – .1m</td> </tr> <tr> <td>VERNIER 11</td> <td>CW</td> </tr> <tr> <td>AMPLITUDE 3</td> <td>5.0 – 2.0</td> </tr> <tr> <td>VERNIER 8</td> <td>CW</td> </tr> <tr> <td>AMPLITUDE 4</td> <td>5.0 – 2.0</td> </tr> <tr> <td>VERNIER 9</td> <td>CW</td> </tr> <tr> <td>OFFSET 13</td> <td>OFF</td> </tr> <tr> <td>OFFSET 14</td> <td>OFF</td> </tr> <tr> <td>Mode selector 22</td> <td>NORM</td> </tr> </table>	PULSE PERIOD 1	.1m – 10m	VERNIER 2	CW	PULSE DELAY 6	35n – 1u	VERNIER 7	CCW	PULSE WIDTH 10	1u – .1m	VERNIER 11	CW	AMPLITUDE 3	5.0 – 2.0	VERNIER 8	CW	AMPLITUDE 4	5.0 – 2.0	VERNIER 9	CW	OFFSET 13	OFF	OFFSET 14	OFF	Mode selector 22	NORM	
PULSE PERIOD 1	.1m – 10m																											
VERNIER 2	CW																											
PULSE DELAY 6	35n – 1u																											
VERNIER 7	CCW																											
PULSE WIDTH 10	1u – .1m																											
VERNIER 11	CW																											
AMPLITUDE 3	5.0 – 2.0																											
VERNIER 8	CW																											
AMPLITUDE 4	5.0 – 2.0																											
VERNIER 9	CW																											
OFFSET 13	OFF																											
OFFSET 14	OFF																											
Mode selector 22	NORM																											
4	Adjust pulse period VERNIER 2 to obtain 0.4mS pulse period on display.																											
5	Adjust pulse width VERNIER 11 to obtain 0.1mS pulse width.																											
6	Adjust 1821A Delay (Div) vernier until intensified spot coincides with trailing edge of first pulse.																											
7	Switch Mode switch on 1821A to MIXED.																											
8	Measure pulse width jitter:	< .1 %																										

Table 4-17. Performance Test: Square Wave

TEST SET-UP

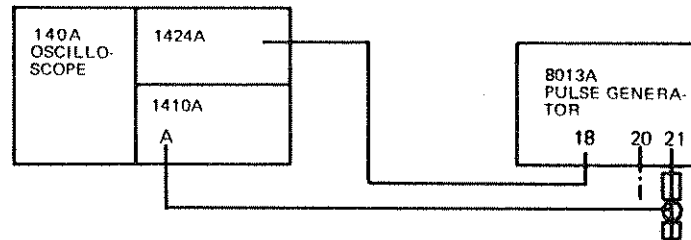

STEP

INSTRUCTIONS

RESULTS

- 1 Set the 8013A controls as follows:
- | | |
|------------------|-------------|
| PULSE PERIOD 1 | 20n – 1u |
| VERNIER 2 | CW |
| PULSE DELAY 6 | 35n – 1u |
| VERNIER 7 | CW |
| PULSE WIDTH 10 | SQUARE WAVE |
| VERNIER 11 | CW |
| AMPLITUDE 3 | 5.0 – 2.0 |
| VERNIER 8 | CW |
| AMPLITUDE 4 | 5.0 – 2.0 |
| VERNIER 9 | CW |
| OFFSET 13 | OFF |
| OFFSET 14 | OFF |
| Mode selector 22 | NORM |
- 2 For each setting of the PULSE PERIOD control 1, given in the table below, turn the VERNIER 2 slowly from fully CCW to fully CW and check that the PULSE DELAY 6 and VERNIER 7 controls have no effect on the position of the displayed pulse.
- | |
|----------------|
| PULSE PERIOD 1 |
| 20n – 1u |
| 1u – .1m |
| .1m – 10m |
| 10m – 1 |
- 3 For all settings of the pulse period control, check that the pulse width (t on) equals the pulse off time (t off)
- 4 Check that the square wave output pulse is symmetrically above and below zero volts.

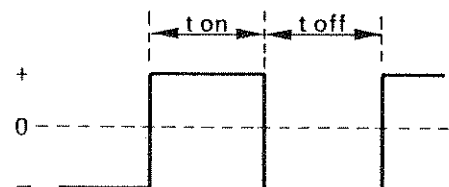
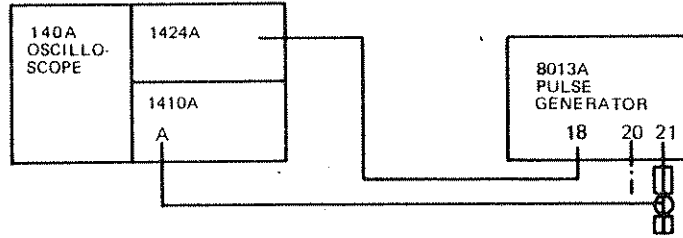

Table 4-18. Performance Test: Duty Cycle.

TEST SET-UP



STEP	INSTRUCTIONS	RESULTS
1	PULSE PERIOD 1 1u - .1m VERNIER 2 CW PULSE DELAY 6 35n - 1u VERNIER 7 CCW PULSE WIDTH 10 1u - .1m VERNIER 11 CCW AMPLITUDE 3 5.0 - 2.0 VERNIER 8 CW AMPLITUDE 4 5.0 - 2.0 VERNIER 9 CW OFFSET 13 OFF OFFSET 14 OFF Mode selector 22 NORM	

2

For each set of control settings given in table below, display the output pulse so that it occupies half of the display (see diagram):

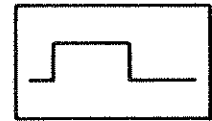

Starting with the pulse period VERNIER 2 fully CW turn VERNIER 2 slowly CCW until the trailing edge of the pulse begins to move or the pulse divides. When this happens measure the pulse period (Tp) and use in the formula:

$$\text{Duty Cycle}_{\text{Max}} = \frac{\text{Pulse Width (Tw)}}{\text{Pulse Period (Tp)}} \cdot 100\%$$

PULSE PERIOD (1)	PULSE WIDTH (10)	VERNIER (11)	RESULTS
1u - .1m	1u - .1m	Adjust for 1uS	> 75 %
.1m - 10m	.1m - 10m	Adjust for 0.1mS	> 75 %
10m - 1	10m - 1	Adjust for 10mS	> 75 %

Table 4-19. Performance Test: Trigger Output.

TEST SET-UP

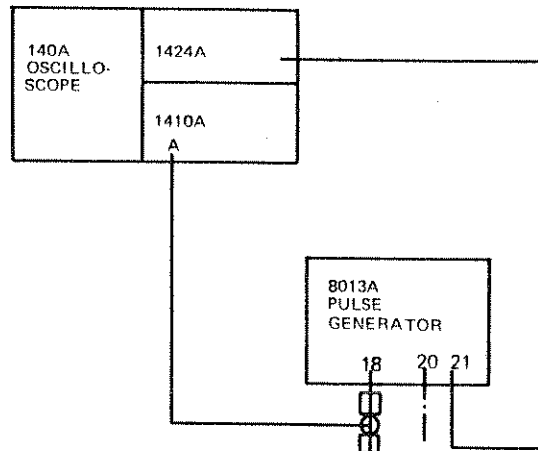

STEP	INSTRUCTIONS	RESULTS
1	Set the 8013A controls as follows: PULSE PERIOD 1 20n – 1u VERNIER 2 CCW PULSE DELAY 6 35n – 1u VERNIER 7 CCW PULSE WIDTH 10 10n – 1u VERNIER 11 CCW AMPLITUDE 3 2.5 – 1.0 VERNIER 8 CW AMPLITUDE 4 2.5 – 1.0 VERNIER 9 CW OFFSETT 13 OFF OFFSET 14 OFF Mode selector 22 NORM	
2	Measure amplitude of trigger output pulse (TRIGGER OUTPUT 18).	> 1.0 V
3	Measure width of trigger output pulse:	> 5nS < 20nS
4	Turn VERNIER 2 slowly from CCW to CW, the amplitude and width limits given must be true for the whole range.	
5	Switch PULSE PERIOD 1 to range 1u – .1m and repeat steps 2 to 4.	
6	Switch PULSE WIDTH 10 to SQUARE WAVE and repeat steps 2 to 5.	

Table 4--20. Performance Test: Amplitude.

TEST SET-UP

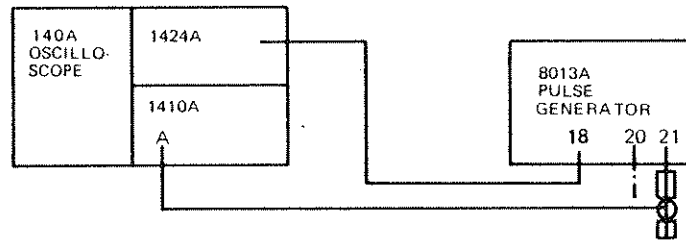

STEP	INSTRUCTIONS	RESULTS
-------------	---------------------	----------------

- | | | | | | | | | | | | | | | | | | | | | | | | | | | | | |
|------------------|---|----------------|----------|-----------|----|---------------|----------|-----------|-----|----------------|----------|------------|-----------|-------------|-----------|-----------|----|-------------|-----------|-----------|----|-----------|-----|-----------|-----|------------------|------|--|
| 1 | Set the 8013A controls as follows:

<table border="0" style="width: 100%;"> <tr><td>PULSE PERIOD 1</td><td>20n – 1u</td></tr> <tr><td>VERNIER 2</td><td>CW</td></tr> <tr><td>PULSE DELAY 6</td><td>35n – 1u</td></tr> <tr><td>VERNIER 7</td><td>CCW</td></tr> <tr><td>PULSE WIDTH 10</td><td>10n – 1u</td></tr> <tr><td>VERNIER 11</td><td>Mid-range</td></tr> <tr><td>AMPLITUDE 3</td><td>5.0 – 2.0</td></tr> <tr><td>VERNIER 8</td><td>CW</td></tr> <tr><td>AMPLITUDE 4</td><td>5.0 – 2.0</td></tr> <tr><td>VERNIER 9</td><td>CW</td></tr> <tr><td>OFFSET 13</td><td>OFF</td></tr> <tr><td>OFFSET 14</td><td>OFF</td></tr> <tr><td>Mode selector 22</td><td>NORM</td></tr> </table> | PULSE PERIOD 1 | 20n – 1u | VERNIER 2 | CW | PULSE DELAY 6 | 35n – 1u | VERNIER 7 | CCW | PULSE WIDTH 10 | 10n – 1u | VERNIER 11 | Mid-range | AMPLITUDE 3 | 5.0 – 2.0 | VERNIER 8 | CW | AMPLITUDE 4 | 5.0 – 2.0 | VERNIER 9 | CW | OFFSET 13 | OFF | OFFSET 14 | OFF | Mode selector 22 | NORM | |
| PULSE PERIOD 1 | 20n – 1u | | | | | | | | | | | | | | | | | | | | | | | | | | | |
| VERNIER 2 | CW | | | | | | | | | | | | | | | | | | | | | | | | | | | |
| PULSE DELAY 6 | 35n – 1u | | | | | | | | | | | | | | | | | | | | | | | | | | | |
| VERNIER 7 | CCW | | | | | | | | | | | | | | | | | | | | | | | | | | | |
| PULSE WIDTH 10 | 10n – 1u | | | | | | | | | | | | | | | | | | | | | | | | | | | |
| VERNIER 11 | Mid-range | | | | | | | | | | | | | | | | | | | | | | | | | | | |
| AMPLITUDE 3 | 5.0 – 2.0 | | | | | | | | | | | | | | | | | | | | | | | | | | | |
| VERNIER 8 | CW | | | | | | | | | | | | | | | | | | | | | | | | | | | |
| AMPLITUDE 4 | 5.0 – 2.0 | | | | | | | | | | | | | | | | | | | | | | | | | | | |
| VERNIER 9 | CW | | | | | | | | | | | | | | | | | | | | | | | | | | | |
| OFFSET 13 | OFF | | | | | | | | | | | | | | | | | | | | | | | | | | | |
| OFFSET 14 | OFF | | | | | | | | | | | | | | | | | | | | | | | | | | | |
| Mode selector 22 | NORM | | | | | | | | | | | | | | | | | | | | | | | | | | | |
| 2 | Check the amplitude for both VERNIER 8 and 9 extremes of each setting of the AMPLITUDE selector 3 and 4 as follows: | | | | | | | | | | | | | | | | | | | | | | | | | | | |

AMPLITUDE 3 (4)	VERNIER 8 (9)	
5.0 – 2.0	CW	> 5.0
5.0 – 2.0	CCW	< 2.0
2.5 – 1.0	CW	> 2.5
2.5 – 1.0	CCW	< 1.0
1.0 – 0.4	CW	> 1.0
1.0 – 0.4	CCW	< 0.4
0.5 – 0.2	CW	> 0.5
0.5 – 0.2	CCW	< 0.2

Table 4-21. Performance Test: DC Offset.

TEST SET-UP

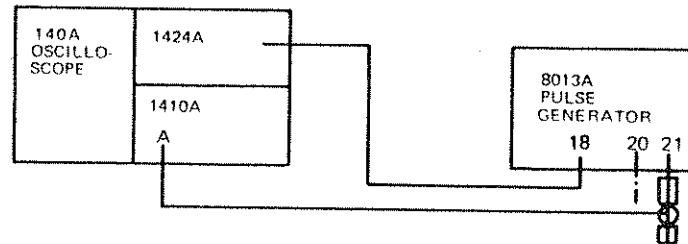

STEP	INSTRUCTIONS	RESULTS
1	Set the 8012A controls as follows: PULSE PERIOD 1 20n – 1u VERNIER 2 CCW PULSE DELAY 6 35n – 1u VERNIER 7 CCW PULSE WIDTH 10 10n – 1u VERNIER 11 CCW AMPLITUDE 3 5.0 – 2.0 VERNIER 8 CW AMPLITUDE 4 5.0 – 2.0 VERNIER 9 CW OFFSET 13 OFF OFFSET 14 OFF Mode selector 22 NORM	
2	Set the output pulse baseline to the center of the oscilloscope display.	
3	Set OFFSET 14 to ON.	
4	Turn VERNIER 15 fully CCW	
5	Measure negative offset:	> -5V
6	Turn VERNIER 15 fully CW.	
7	Measure positive offset:	> +1V
8	Turn OFFSET 14 to OFF.	
9	Output pulse baseline should be at center of oscilloscope display.	
10	Repeat steps 2 to 9 for OFFSET 13 and VERNIER 12 but with the following limits: VERNIER 12 fully CCW VERNIER 12 fully CW	> -1V > +5V

Table 4-22. Performance Test: Baseline Position.

TEST SET-UP

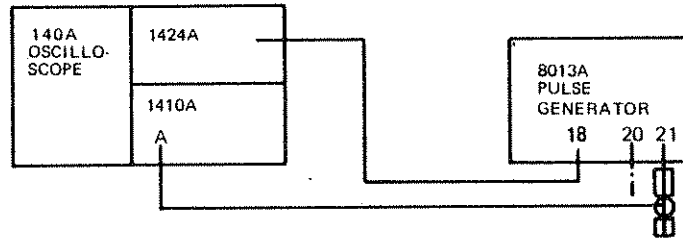

STEP	INSTRUCTIONS	RESULTS
1	Set the 8012A controls as follows: PULSE PERIOD 1 20n – 1u VERNIER 2 CW PULSE DELAY 6 35n – 1u VERNIER 7 CW PULSE WIDTH 10 10n – 1u VERNIER 11 Adjust for a duty cycle of 50%. AMPLITUDE 3 5.0 – 2.0 VERNIER 8 CW AMPLITUDE 4 5.0 – 2.0 VERNIER 9 CW OFFSET 13 OFF OFFSET 14 OFF Mode selector 22 NORM.	
2		
3	Disconnect 8012A from oscilloscope	
4	Center the oscilloscope display trace.	
5	Reconnect 8013A to oscilloscope.	
6	Check that output pulse baseline is in center of display.	

Table 4-23. Performance Test: Output Impedance.

TEST SET-UP

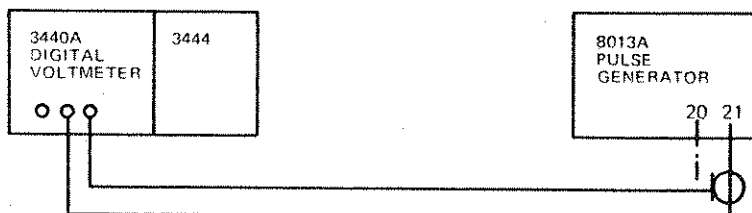

STEP	INSTRUCTIONS	RESULTS																												
1	<p>Set the 8013A controls as follows:</p> <table border="0"> <tr><td>LINE 15</td><td>OFF</td></tr> <tr><td>PULSE PERIOD 1</td><td>20n - 1u</td></tr> <tr><td>VERNIER 2</td><td>CW</td></tr> <tr><td>PULSE DELAY 6</td><td>35n - 1u</td></tr> <tr><td>VERNIER 7</td><td>CCW</td></tr> <tr><td>PULSE WIDTH 10</td><td>10n - 1u</td></tr> <tr><td>VERNIER 11</td><td>SQUARE WAVE</td></tr> <tr><td>AMPLITUDE 3</td><td>5.0 - 2.0</td></tr> <tr><td>VERNIER 8</td><td>CW</td></tr> <tr><td>AMPLITUDE 4</td><td>5.0 - 2.0</td></tr> <tr><td>VERNIER 9</td><td>CW</td></tr> <tr><td>OFFSETT 13</td><td>OFF</td></tr> <tr><td>OFFSET 14</td><td>OFF</td></tr> <tr><td>Mode selector 22</td><td>NORM.</td></tr> </table>	LINE 15	OFF	PULSE PERIOD 1	20n - 1u	VERNIER 2	CW	PULSE DELAY 6	35n - 1u	VERNIER 7	CCW	PULSE WIDTH 10	10n - 1u	VERNIER 11	SQUARE WAVE	AMPLITUDE 3	5.0 - 2.0	VERNIER 8	CW	AMPLITUDE 4	5.0 - 2.0	VERNIER 9	CW	OFFSETT 13	OFF	OFFSET 14	OFF	Mode selector 22	NORM.	
LINE 15	OFF																													
PULSE PERIOD 1	20n - 1u																													
VERNIER 2	CW																													
PULSE DELAY 6	35n - 1u																													
VERNIER 7	CCW																													
PULSE WIDTH 10	10n - 1u																													
VERNIER 11	SQUARE WAVE																													
AMPLITUDE 3	5.0 - 2.0																													
VERNIER 8	CW																													
AMPLITUDE 4	5.0 - 2.0																													
VERNIER 9	CW																													
OFFSETT 13	OFF																													
OFFSET 14	OFF																													
Mode selector 22	NORM.																													
2	<p>Turn amplitude VERNIER 9 from fully CW to fully CCW and check resistance:</p>	$50 \Omega \pm 4 \Omega$																												

Table 4-24. Initial Settings of 8013A for Internal Checks and Adjustments: Assembly 1.

TEST SET-UP 1



TEST SET-UP 2

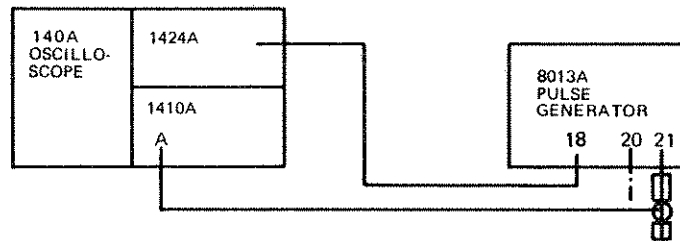

TEST SET-UP 3

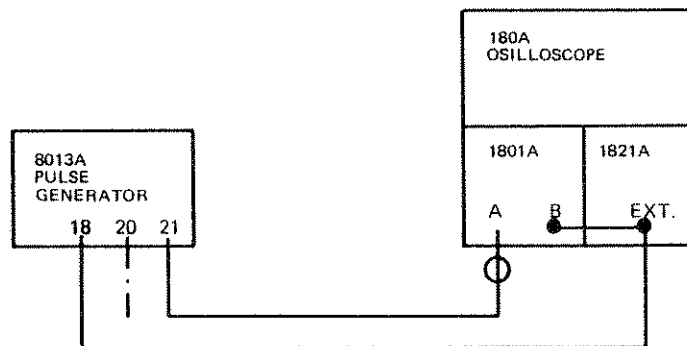

Set the 8013A controls as follows:

PULSE PERIOD 1	20n - 1u
VERNIER 2	CW
PULSE DELAY 6	35n - 1u
VERNIER 7	CCW
PULSE WIDTH 10	10n - 1u
VERNIER 11	CW
AMPLITUDE 3	5.0 - 2.0
VERNIER 8	CW
AMPLITUDE 4	5.0 - 2.0
VERNIER 9	CW
OFFSET 13	OFF
OFFSET 14	OFF
Mode selector 22	NORM

Table 4-25. Internal Checks and Adjustments: Assembly 1
Refer to Table 4-24 for the test set-up and initial settings.

Step	INSTRUCTIONS	ADJUST	RESULT
	Pulse Period		
1	Connect equipment as shown in TEST SET-UP 1		
2	Turn VERNIER 2 fully CCW		
3	Measure the pulse period:	A1C24	51 MHz.
	Pulse Width		
4	Connect equipment as shown in TEST SET-UP 2.		
5	Turn VERNIER 11 fully CCW		
6	Measure the pulse width:	A1C45	9nS
	Pulse Delay		
7	Connect equipment as shown in TEST SET-UP 3 and reset the controls as follows:		
	PULSE PERIOD 1	1 μ – 0.1m	
	VERNIER 2	CW	
	VERNIER 7	CW	
	VERNIER 11	CW	
8	Measure the delay between the trigger pulse and the output pulse:	A1C35	< 35nS

Table 4--26. Internal Checks and Adjustments: Assembly 2

TEST SET-UP

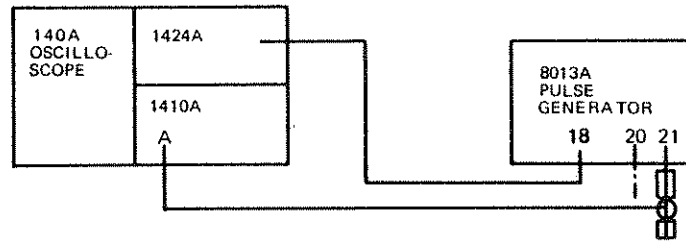

STEP	INSTRUCTIONS	ADJUST	RESULT
1	Set the 8013 controls as follows:		
	PULSE PERIOD 1	10n - 1u	
	VERNIER 2	CCW	
	PULSE DELAY 6	35n - 1u	
	VERNIER 7	CCW	
	PULSE WIDTH 10	SQUARE WAVE	
	VERNIER 11		
	AMPLITUDE 3	5.0 - 2.0	
	VERNIER 8	CW	
	AMPLITUDE 4	5.0 - 2.0	
	VERNIER 9	CW	
	OFFSET 13	OFF	
	OFFSET 14	OFF	
	Mode selector 22	NORM.	

Pulse shape: OUTPUT (+)

- 2 Observe the pulse for correct shape while turning VERNIER 9 from fully CW to fully CCW

A2C5
A2R19

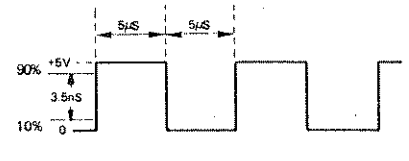

Pulse shape: OUTPUT (-)

- 3 Observe the pulse for correct shape while turning VERNIER 8 from fully CW to fully CCW

A2C16
A2R50

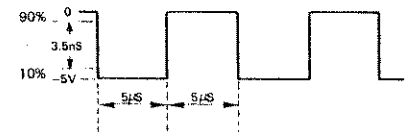

Table 4-27. Internal Checks and Adjustments: Assembly 3

STEP	INSTRUCTIONS	ADJUST	RESULT
1	Set the 8013A controls as follows:		
	PULSE PERIOD 1	EXT+	
	VERNIER 2	CW	
	PULSE DELAY 6	1 μ – 0.1m	
	VERNIER 7	CCW	
	PULSE WIDTH 10	1 μ – 0.1m	
	VERNIER 11	CCW	
	AMPLITUDE 3	5.0 – 2.0	
	VERNIER 8	CW	
	AMPLITUDE 4	5.0 – 2.0	
	VERNIER 9	CW	
	OFFSET 13	ON	
	VERNIER 12	Mid-range	
	OFFSET 14	ON	
	VERNIER 15	Mid-range	
	Mode selector 22	NORM.	
	Voltages are measured with respect to chassis.		
2	Connect the digital voltmeter to TP1 on board A3.	A3R15	+17V \pm 100mV
3	Connect the ac voltmeter to TP1 on board A3 and observe the ripple.		2mV rms
4	Connect the digital voltmeter to TP 2 on board A3.	A3R16	-17V \pm 100mV
5	Connect the ac voltmeter to TP2 on board A3 and observe the ripple.		2mV rms

SECTION V DIAGRAMS AND REPLACEABLE PARTS

5-1 INTRODUCTION

5-2 This section provides the block, functional, circuit, component location and troubleshooting diagrams and replaceable parts information necessary for servicing the pulse generator.

5-3 ASSEMBLY AND COMPONENT REFERENCING

5-4 The pulse generator consists of four assemblies (A1 to A4) mounted in a frame; assemblies 3 and 4 are attached directly to the frame and assemblies 1 and 2 plug into connectors on assembly 3. Components mounted on an assembly are identified by prefixing the reference designator by the appropriate assembly reference, thus, for example, diode 7 on assembly 2 becomes A2CR7. Components mounted directly on the frame have no prefix.

5-5 ORGANIZATION OF DIAGRAMS

5-6 A block diagram (figure 5-2) indicates the way in which the instrument functions and shows circuit location by means of the assembly reference.

5-7 Electrical parts, and some mechanical parts, belonging to the frame are shown in the assembly location diagram (figure 5-3) and the facing parts table.

5-8 Detailed information for each assembly is presented by a component location diagram, a parts table and a circuit diagram. When necessary, the parts table includes a grid reference so that a component can be located on circuit and component location diagrams. Circuit diagrams include interconnections to the next assembly.

5-9 Exceptionally, no separate circuit diagram is provided for assembly 3. This is because the assembly is essentially an interconnector and contains only a few components. The information, however, is presented on the circuit diagrams of other assemblies, as appropriate.

5-10 ORDERING INFORMATION

5-11 General

5-12 The replaceable parts tables list parts in alpha-numerical order of their reference designators and

indicates the description and HP stock number of each part, together with any applicable notes.

5-13 To order a replacement part, address order of inquiry either to your authorized Hewlett-Packard sales representative or to:

CUSTOMER SERVICE
Hewlett-Packard Company
333 Logue Avenue
Mountain View, California 94040

or, in Western Europe, to:

Hewlett-Packard S.A.
Rue du Bois-du-Lan 7
1217 Meyrin 2
Geneva
Switzerland

5-14 Specify the following information for each part:

- a) Model and complete serial number of instrument.
- b) Hewlett-Packard stock number.
- c) Circuit reference designator.
- d) Description.

To order a part not listed, give a complete description of the part and include its function and location.

5-15 Assembly Exchange Programs

5-16 Assembly exchange programs, in which rebuilt and fully-tested assemblies are delivered in exchange for faulty assemblies, are available for some instruments. When ordering an exchange assembly it must be remembered that the seventh digit of the stock number changes from 6 as quoted in the replaceable parts table to 9, for example:

New assembly A4, stock number XXXXX-66504
Exchange assembly A4, stock number XXXXX-69504

Table 5-1. General Symbols and Reference Designators

REFERENCE DESIGNATORS							
A	= assembly	F	= fuse	P	= plug	V	= vacuum tube, neon bulb, photocell, etc.
B	= motor	FL	= filter	Q	= transistor	VR	= voltage regulator
BT	= battery	HR	= heater	R	= resistor	W	= cable
C	= capacitor	J	= jack	RT	= thermistor	X	= socket
CP	= coupler	K	= relay	S	= switch	Y	= crystal
CR	= diode	L	= inductor	T	= transformer		
DL	= delay line	M	= meter	TB	= terminal board		
DS	= lamp	MC	= micro-circuit	TP	= test point		

Typical Front Panel Legend

(a) (b)

9 · 7 · 5

Typical Rear Panel Legend

115 - 230

a. Typical edge connector showing pin number

b. Typical spring contact connector showing pin number.

Insulated wire with colours White, Violet, Green.

9 · 7 · 5

Transistor
Pin Identification From Top

Zener Diode

Centre Conductor
Screen
Screened Lead

QUALIFICATION OF COMPONENT VALUE

*Indicates that optimum value is selected at factory

COLOUR CODE

0	Black	4	Yellow	7	Violet
1	Brown	5	Green	8	Grey
2	Red	6	Blue	9	White
3	Orange				

Unless otherwise indicated:
capacitance in microfarads
inductance in microhenries
resistance in ohms

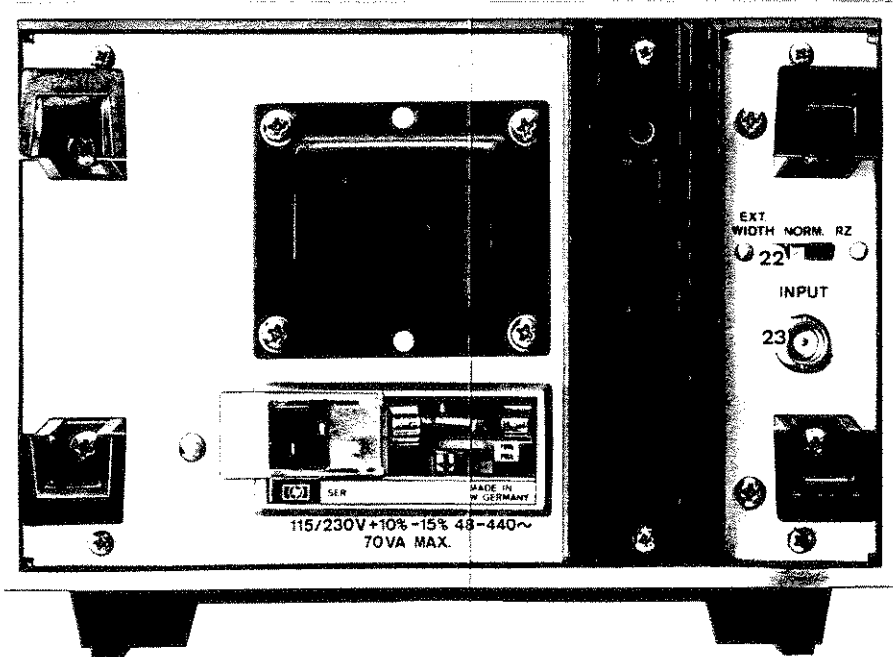
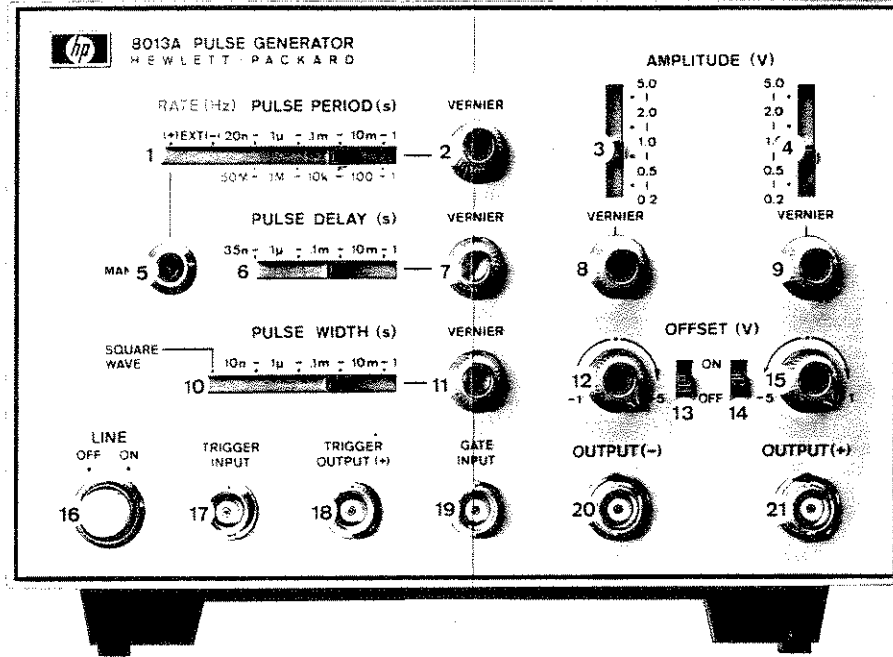

Figure 5-1 8013A Front and Rear Panels: Control Identification Diagrams

Model 8013A

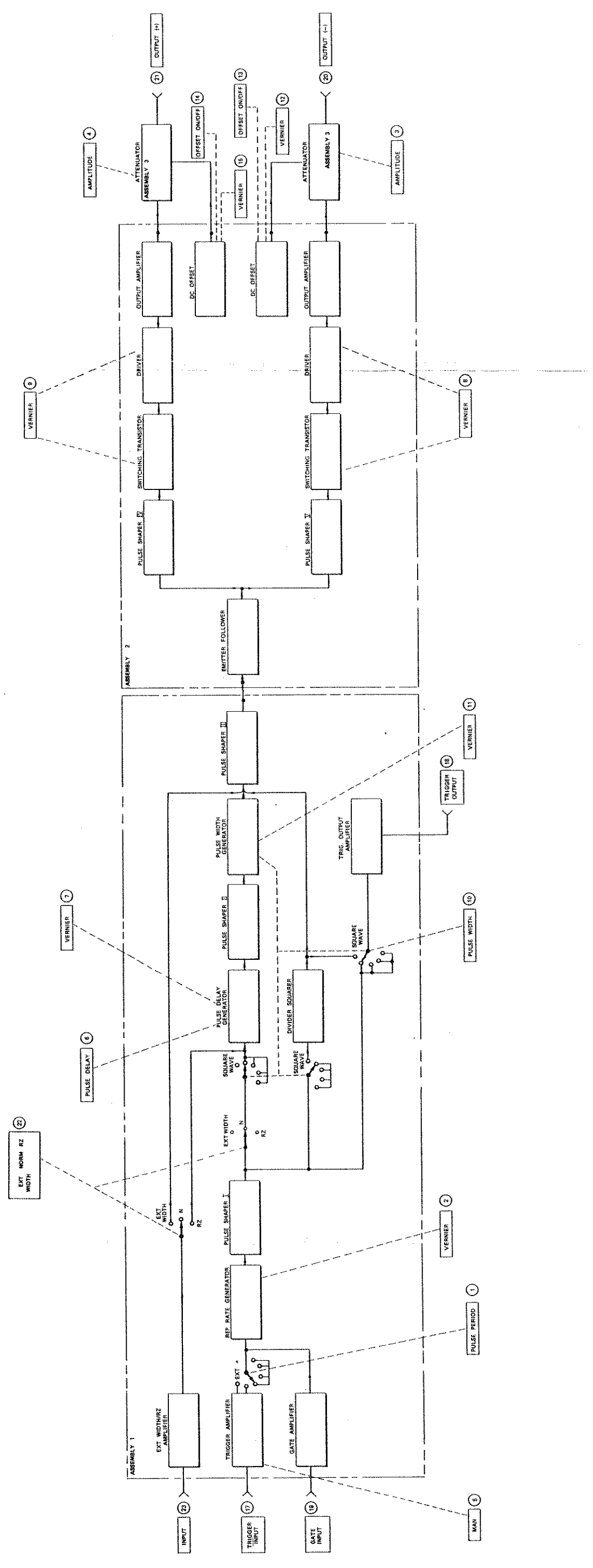

Figure 5-2 Block Diagram

Table 5-2 Replaceable Parts: Frame

REFERENCE DESIGNATOR	HP PART NUMBER	DESCRIPTION	CIRCUIT DIAGRAM		COMPONENT LAYOUT
			SHEET NUMBER	GRID REFERENCE	
A1	08012-66501	RD AY TIMC			
A2	08013-66502	RD AY PULSAMPL			
A3	08013-66503	RD AY WITH			
A4	08012-66504	RD AY PWR SPLY			
J1	1250-0118	CONN RNC BLKHD			
J2	1250-0118	SAME AS J 1			
J3	1250-0118	SAME AS J 1			
J4	1240-0083	CONN RNC BLKHD			
Q1	1854-0043	XSTR 2N3055 SI			
Q2	1854-0063	SAME AS Q 1			
R1	2100-3081	R-VAR 50K-25M CC			
R2	2100-3081	SAME AS R 1			
R3	2100-3081	SAME AS R 1			
R4	0758-0024	R-F 100 5% .25W			
R5	0758-0126	R-F 51 5% .25W F			
R6	0758-0048	R-F 3K5% .25W F			
R25	2100-2435	R-VAR 10K .75W			
R26	2100-2435	SAME AS R 25			
P33	2100-2146	R-VAR 10K .75W			
R34	2100-2146	SAME AS R 33			
S5	3101-0124	SW-P-RTN SPST			
S10	3101-1248	SW P-BTN SPDT			
S4	3101-0903	SW-P-BTN-SPST			
X1	5080-1189	PWR LINE MDL			
T1	5080-0948	XFRMRPWR			
W1	08012-61605	CABLE-COAXIAL			
W2	08013-61601	COAXIAL CABLES (SET OF 2)			
W3	08013-61602	COAXIAL CABLES AND PLUG ASSY. (SET OF 2)			
W4	08012-61602	SCREENED POWER CABLE			

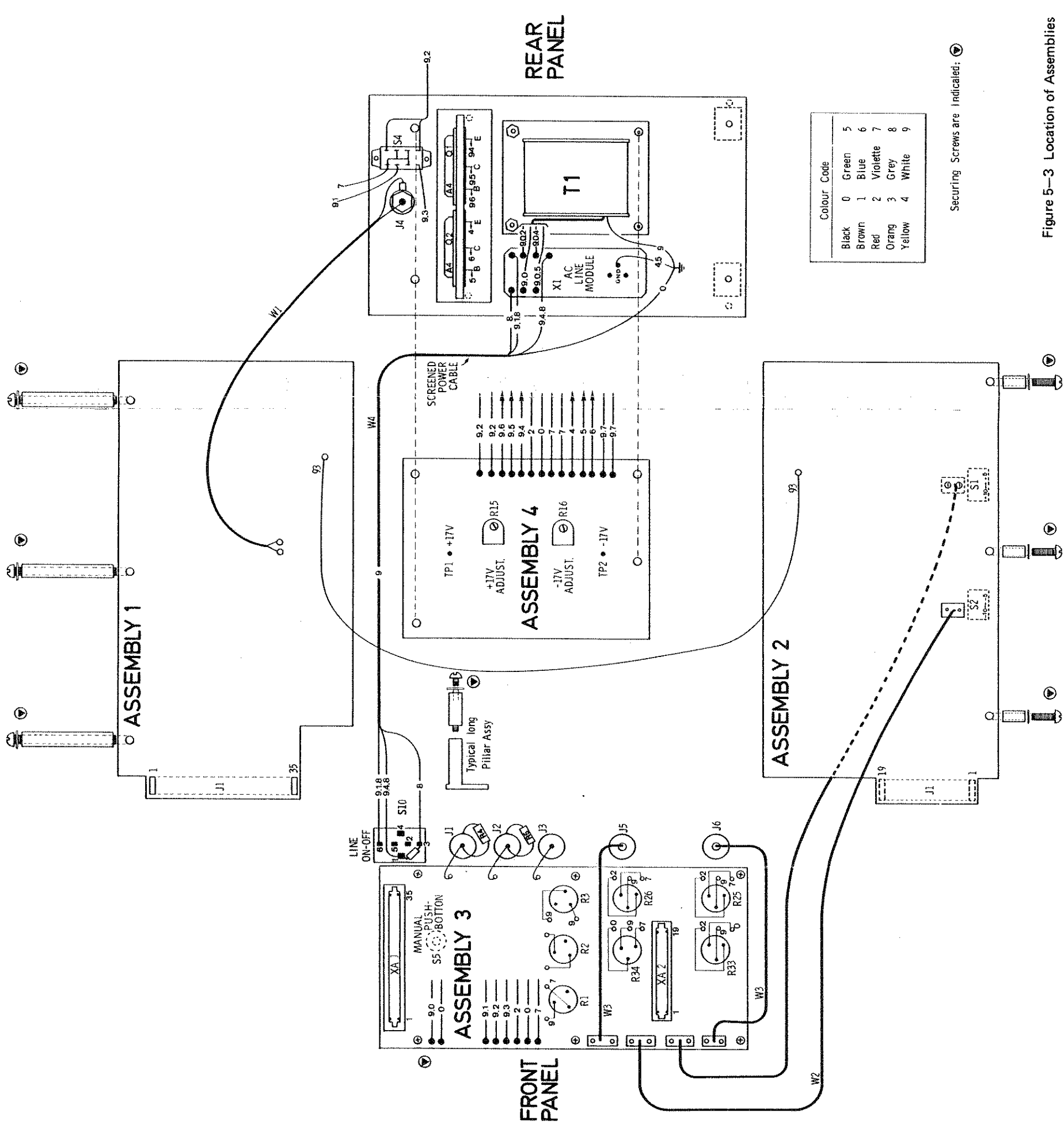

Figure 5-3 Location of Assemblies

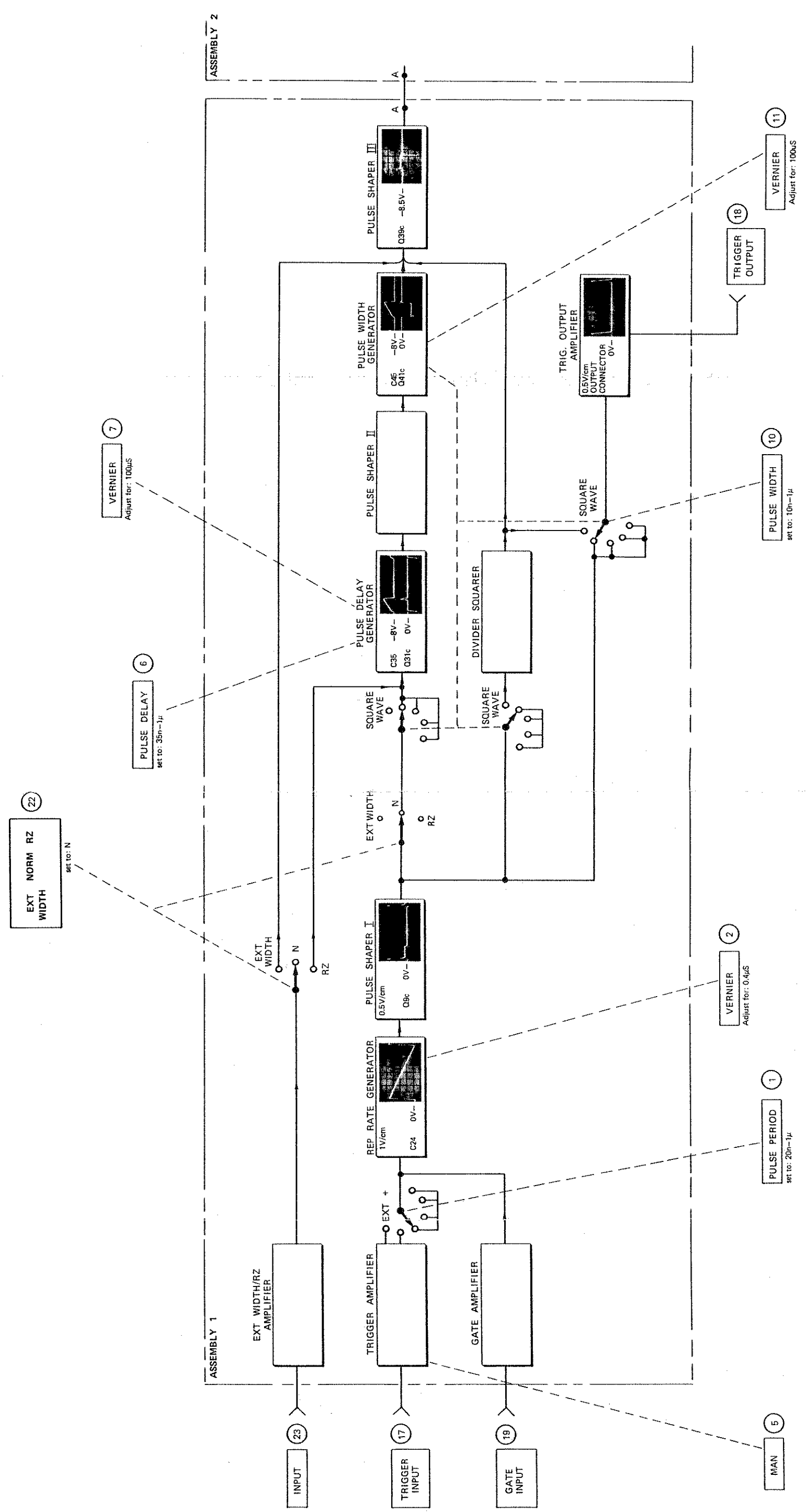

Figure 5-4 Troubleshooting Flowchart: Normal Mode — Internal Trigger Sheet 1 of 2

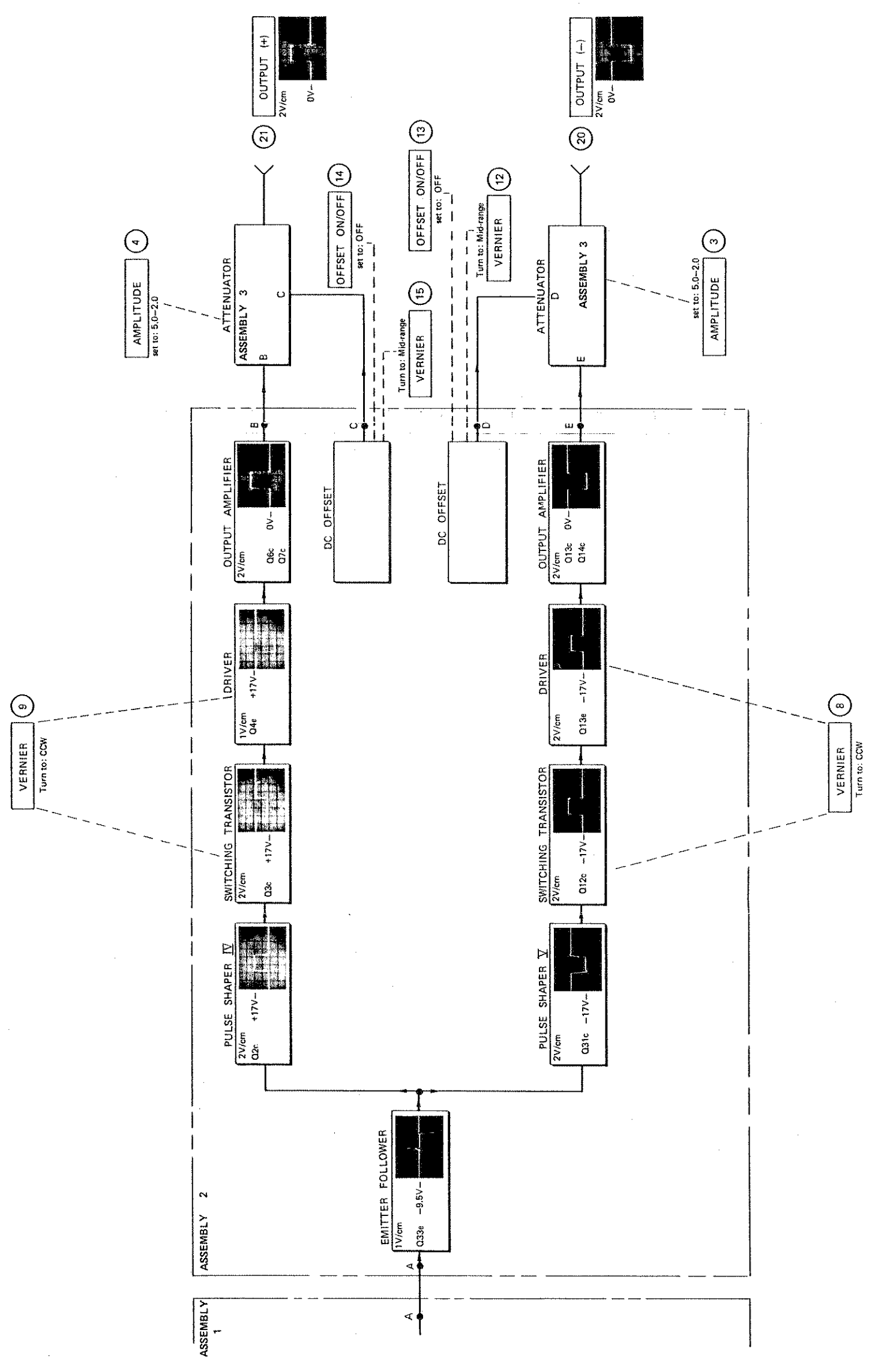

Figure 5-4 Troubleshooting Flowchart: Normal Mode - Internal Trigger Sheet 2 of 2

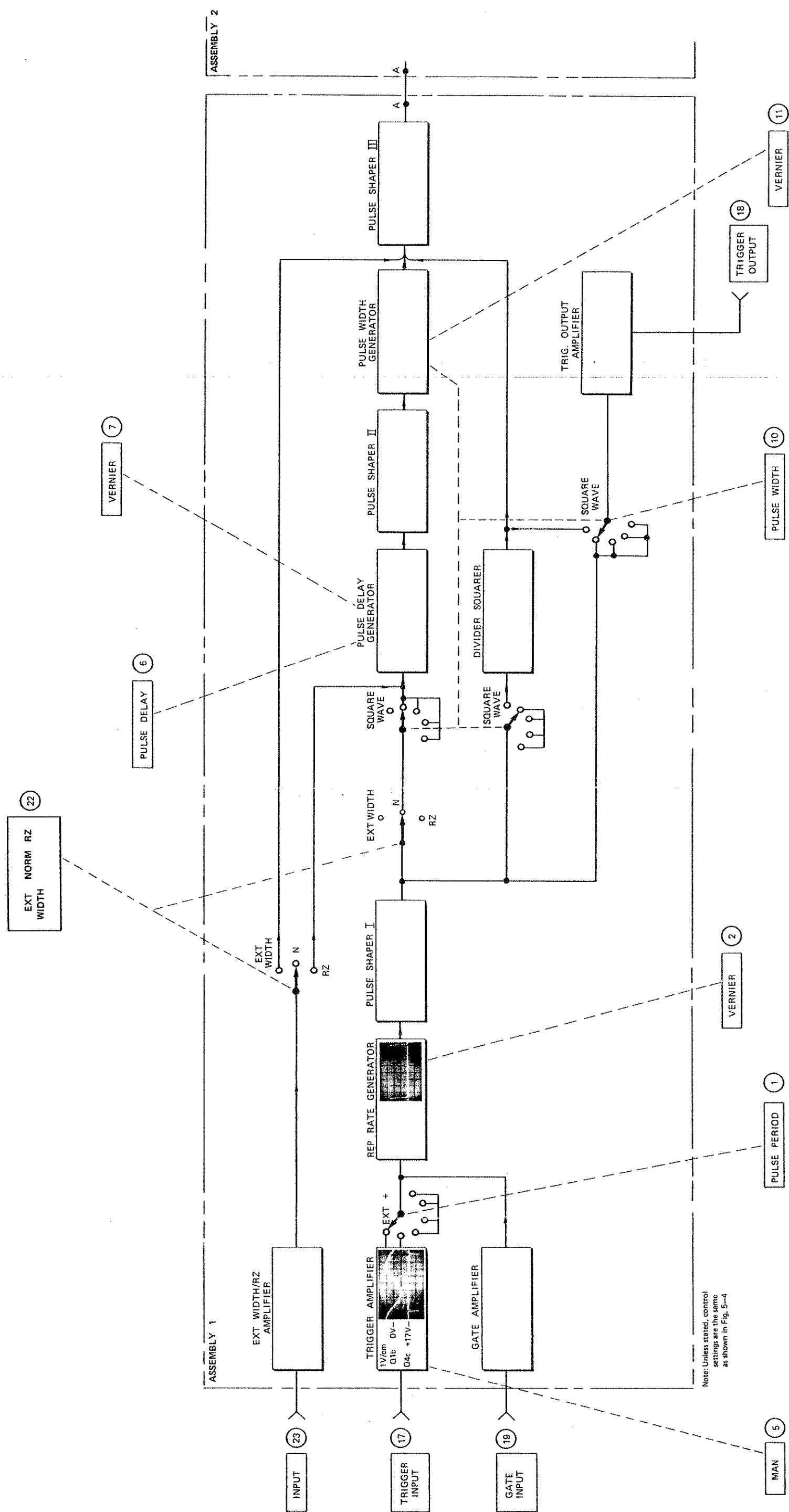

Figure 5-5 Troubleshooting Flowchart: Normal Mode - External Trigger

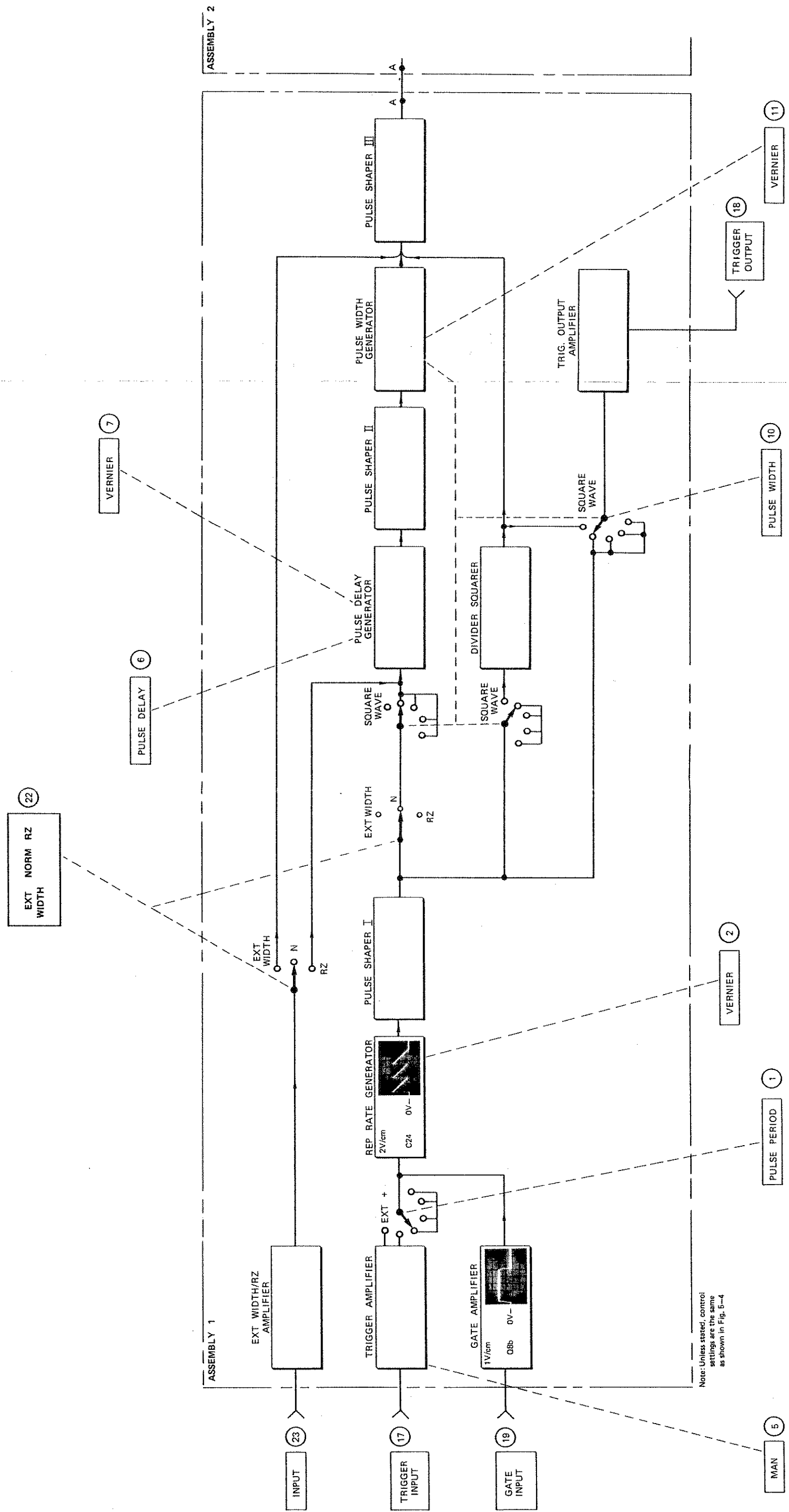

Figure 5-6 Troubleshooting Flowchart: Normal Mode - Gate

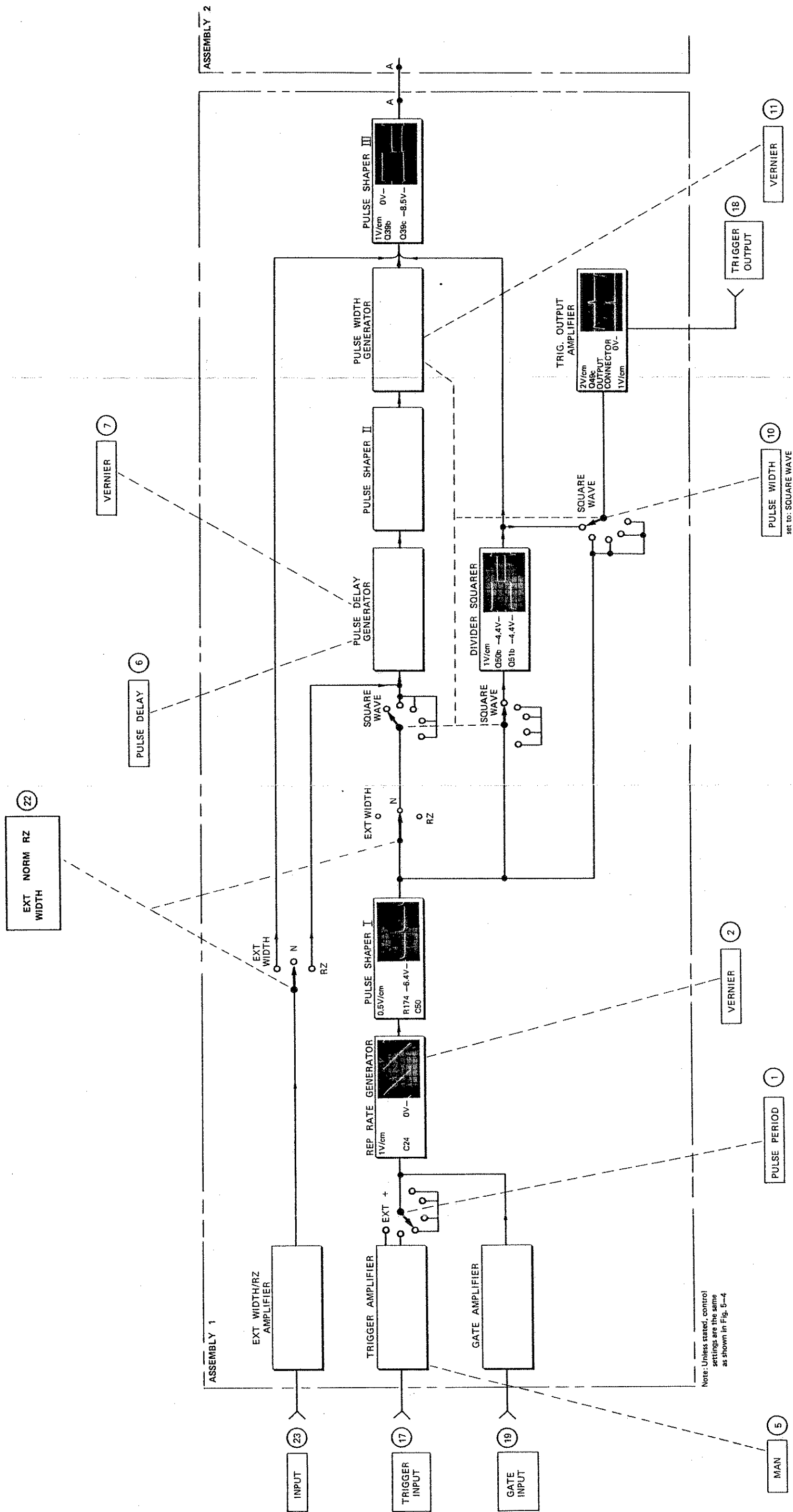

Figure 5-7 Troubleshooting Flowchart: Normal Mode - Square Wave

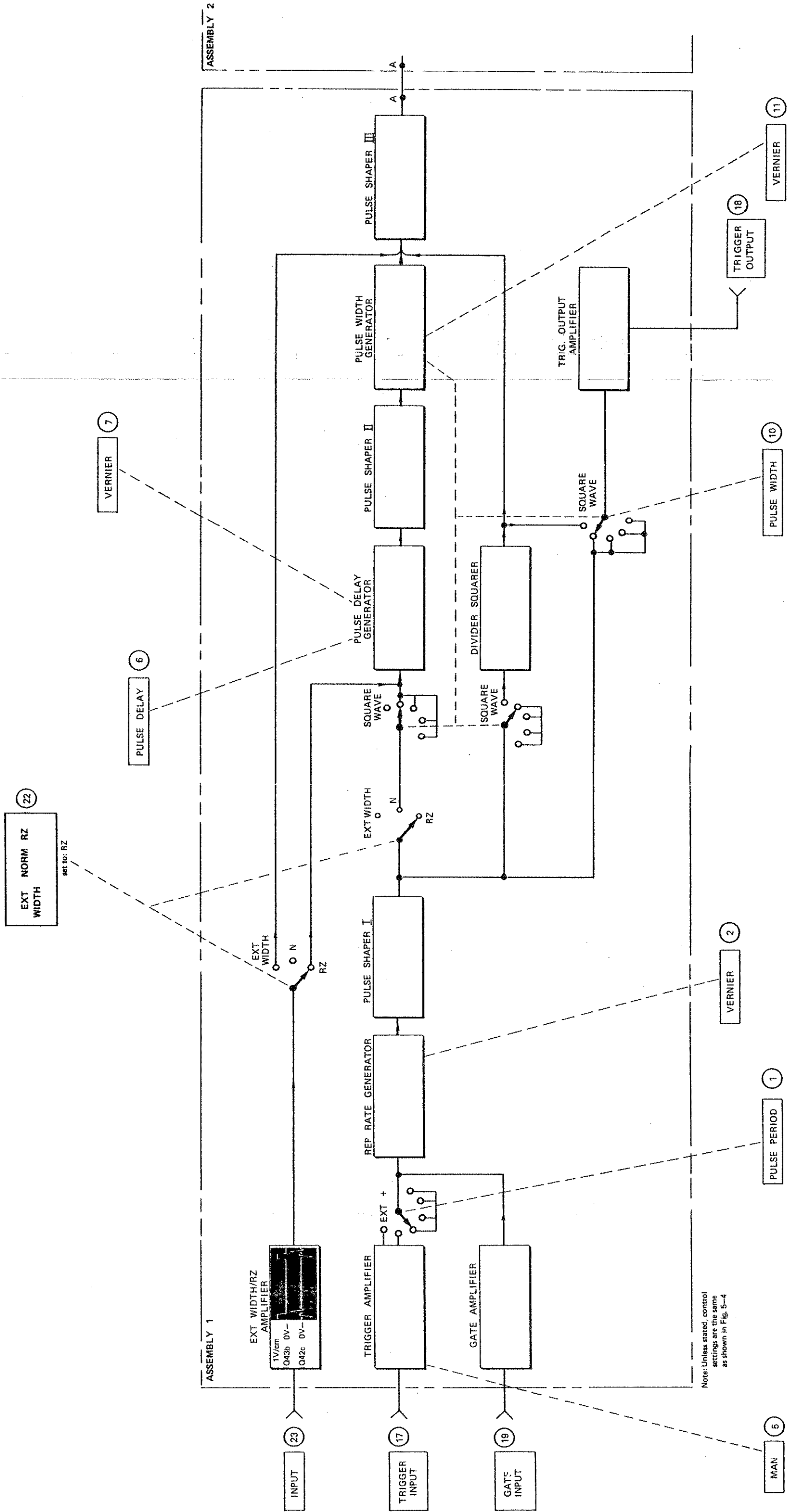

Figure 5-8 Troubleshooting Flowchart: RZ Mode

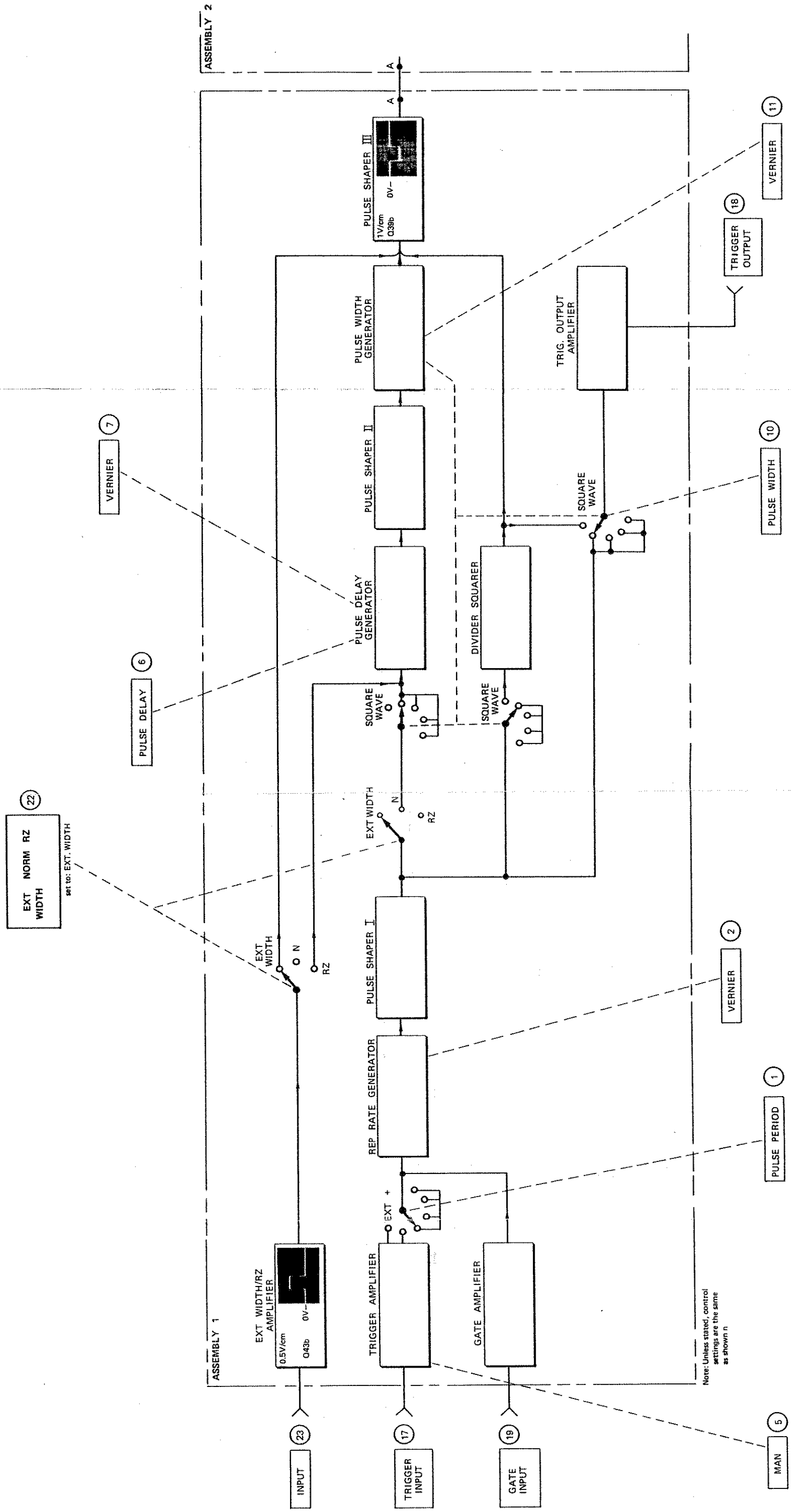

Figure 5-9 Troubleshooting Flowchart: External Width Mode

A B C D E F G H J K L M N O P R

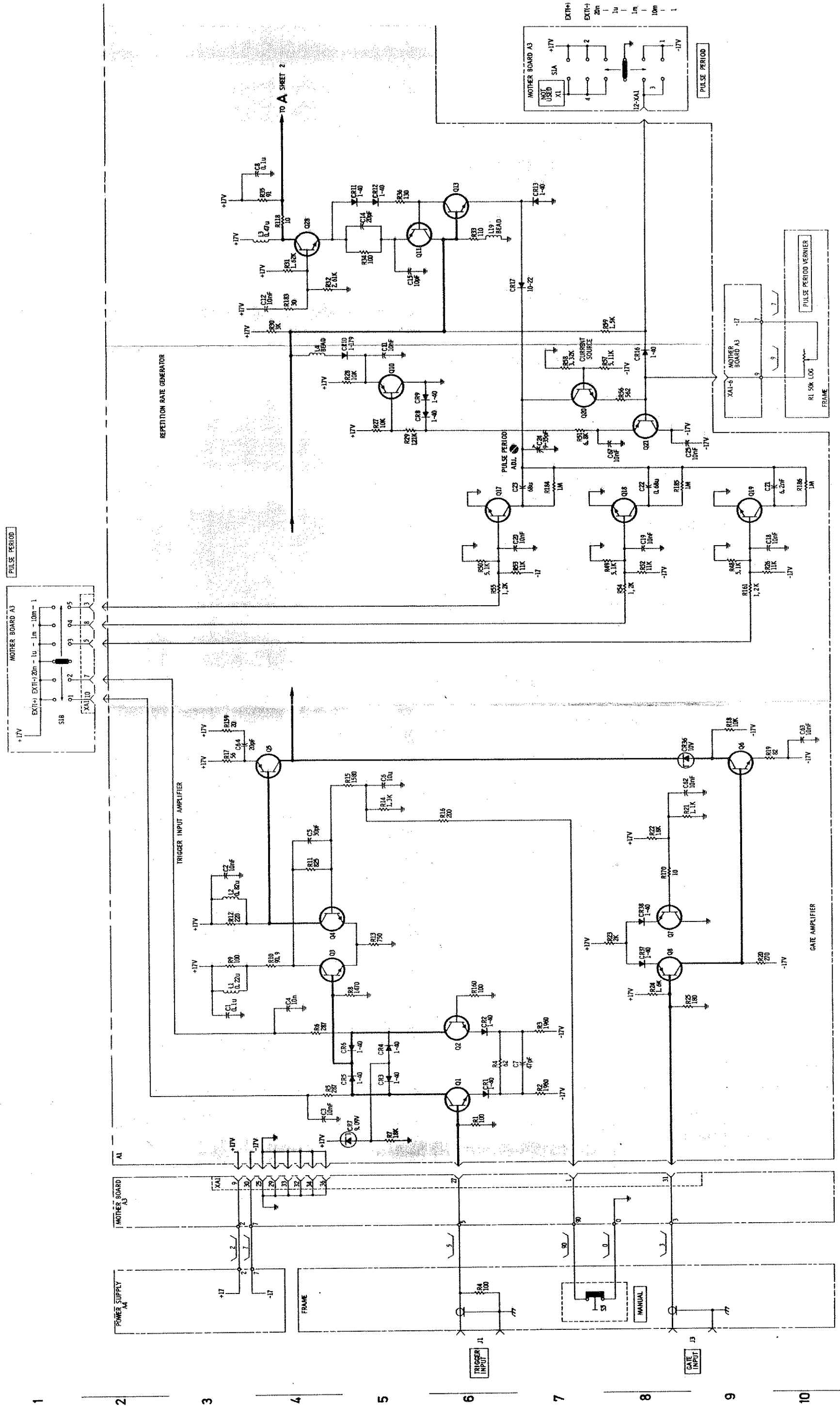

Figure 5-11 Circuit Diagram: Assembly 1 Sheet 1 of 4

A B C D E F H J K L M

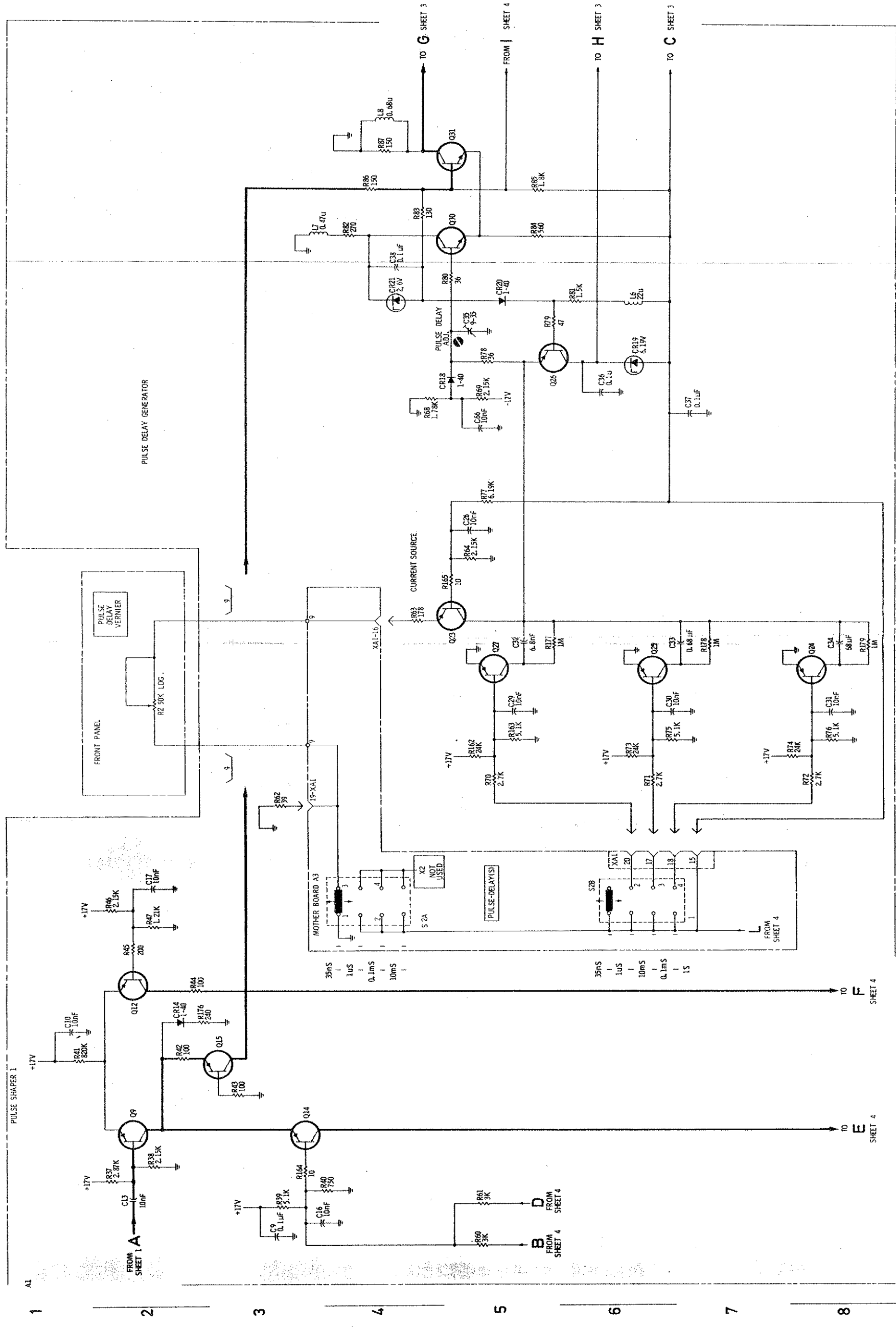

Figure 5-11 Circuit Diagram: Assembly 1 Sheet 2 of 4

A B C D E F G H J K L M N

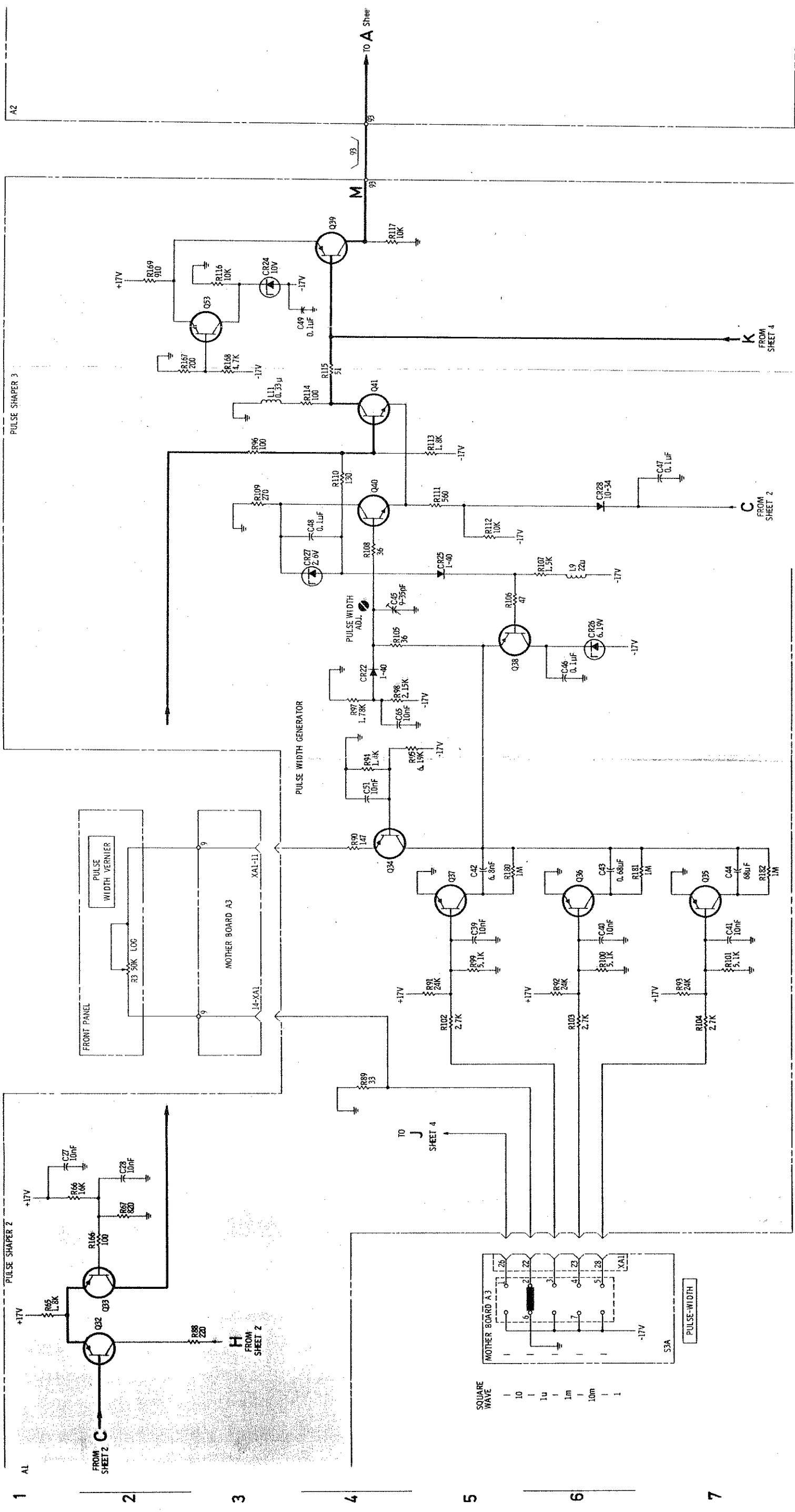

Figure 5-11 Circuit Diagram: Assembly 1 Sheet 3 of

Model 8013A A B C D E F G H J K L M N

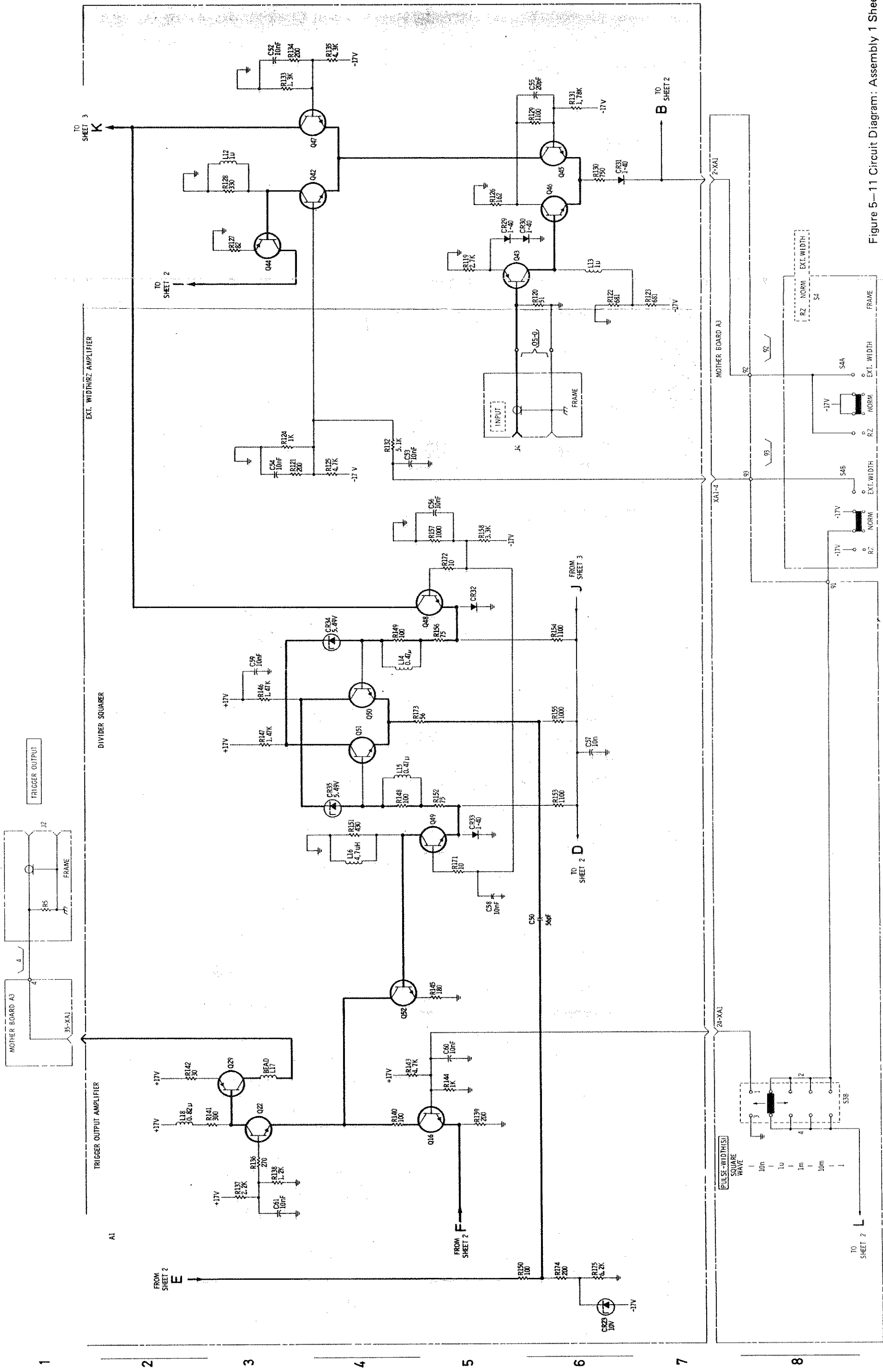

Figure 5-11 Circuit Diagram: Assembly 1 Sheet 4 of 4

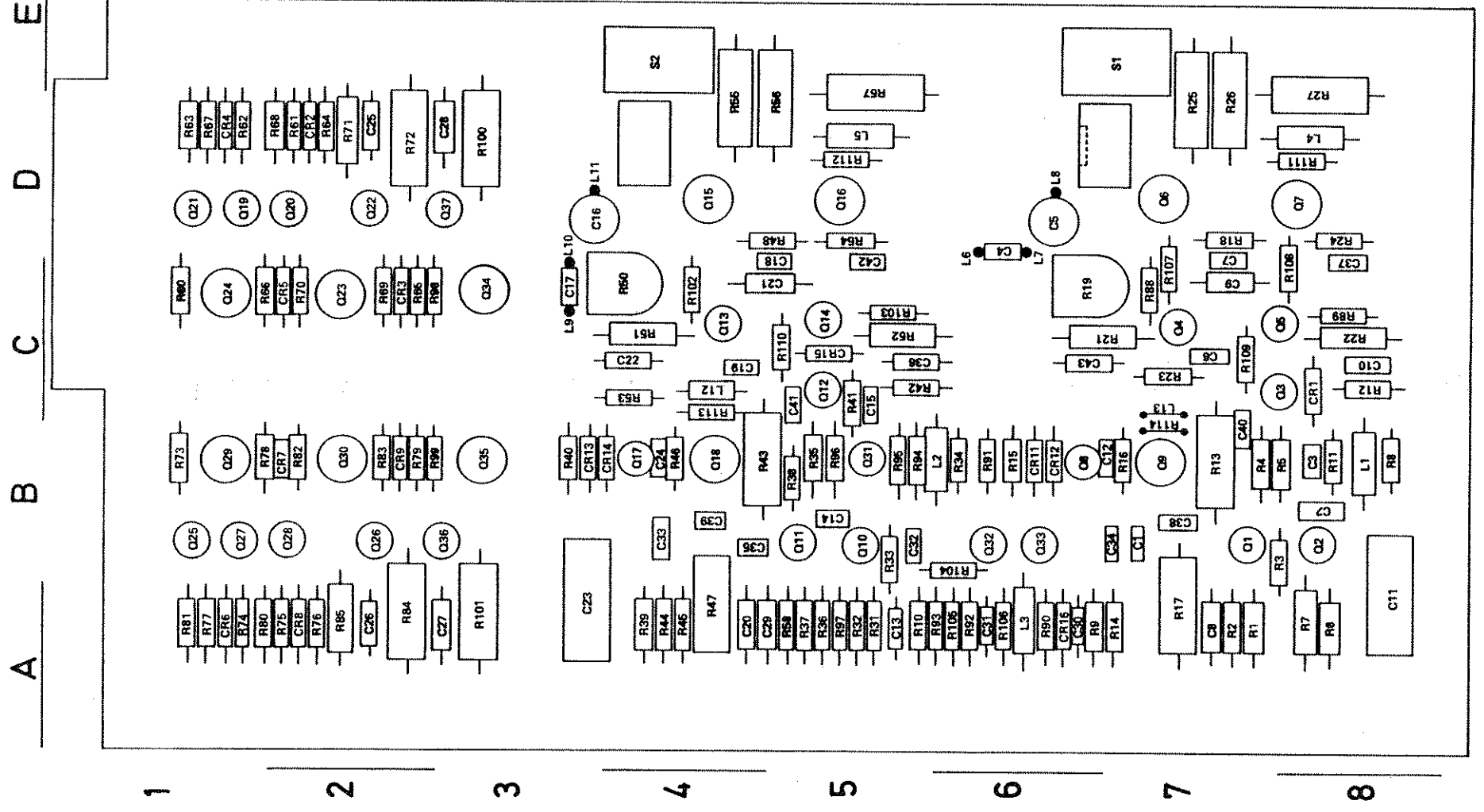

Figure 5-12 Component Layout: Assemblies 2 and 3

Table 5-4 Replaceable Parts: Assembly 2

REFERENCE DESIGNATOR	H-P PART NUMBER	DESCRIPTION	CIRCUIT SHEET NUMBER	DIAGRAM GRID REFERENCE	COMPONENT LAYOUT	
A2	R41	0698-4247	R-F 510 5% .125W	1	G8	C5
A2	R42	0698-4239	R-F 220 5% .125W	1	G8	C5
A2	R43	0761-0042	R-F 68 5% 1W MO	1	H8	B4
A2	R44	0757-0443	R-F 11K1% .125W	1	G10	A4
A2	R45	0698-4236	R-F 160 5% .125W	1	H10	A5
A2	R46	0698-4249	R-F 620 5% .125W	1	H9	B4
A2	R47	0760-0024	R-F 100 5% 1W MO	1	H9	A4
A2	R48	0683-4705	R-F 47 5% .25W	1	I7	D4
A2	R50	2100-2796	R-VAR 100 .5W	1	I8	C4
A2	R51	0698-5887	R-F 30 5% .25W F	1	J9	C4
A2	R52	0698-5887	R-F 30 5% .25W F	1	J9	C5
A2	R53	0698-4236	R-F 160 5% .125W	1	K9	C4
A2	R54	0683-4705	R-F 47 5% .25W	1	J7	D5
A2	R55	0761-0035	R-F 150 5% 1W MO	1	J6	D4
A2	R56	0761-0035	R-F 150 5% 1W MO	1	J6	D4
A2	R57	0761-0035	R-F 150 5% 1W MO	1	J6	E5
A2	R58	0698-4254	R-F 1K5% .125W F	1	C7	A5
A2	R60	0757-0289	R-F 13.3K1% .125W	2	C6	C1
A2	R61	0698-4239	R-F 220 5% .125W	2	C6	D2
A2	R62	0698-4239	R-F 220 5% .125W	2	C6	D1
A2	R63	0757-0289	R-F 13.3K1% .125W	2	C7	D1
A2	R64	0757-0289	R-F 13.3K1% .125W	2	C5	D2
A2	R65	0757-0280	R-F 1K1% .125W F	2	D5	C2
A2	R66	0757-0280	R-F 1K1% .125W F	2	D7	C1
A2	R67	0757-0280	R-F 1K1% .125W F	2	D6	D1
A2	R68	0757-0280	R-F 1K1% .125W F	2	D6	D1
A2	R69	0698-4251	R-F 750 5% .125W	2	D6	C2
A2	R70	0698-4251	R-F 750 5% .125W	2	D6	C2
A2	R71	0758-0096	R-F 110 5% .25W	2	E7	D2
A2	R72	0760-0012	R-F 51 2% 1W MO	2	E5	D2
A2	R73	0757-0289	R-F 13.3K1% .125W	2	C2	B1
A2	R74	0698-4239	R-F 220 5% .125W	2	C2	A1
A2	R75	0698-4239	R-F 220 5% .125W	2	C3	A2
A2	R76	0757-0289	R-F 13.3K1% .125W	2	C3	A2
A2	R77	0757-0289	R-F 13.3K1% .125W	2	C1	A1
A2	R78	0757-0280	R-F 1K1% .125W F	2	D1	B1
A2	R79	0757-0280	R-F 1K1% .125W F	2	D4	B2
A2	R80	0757-0280	R-F 1K1% .125W F	2	D3	A1
A2	R81	0757-0280	R-F 1K1% .125W F	2	D2	A1
A2	R82	0698-4251	R-F 750 5% .125W	2	D2	B2
A2	R83	0698-4251	R-F 750 5% .125W	2	D3	B2
A2	R84	0760-0012	R-F 51 2% 1W MO	2	E4	A2
A2	R85	0758-0096	R-F 110 5% .25W	2	E1	A2
A2	R88	0698-4258	R-F 1.5K5% .125W	1	I2	C7
A2	R89	0698-4258	R-F 1.5K5% .125W	1	J2	C8
A2	R90	0698-4231	R-F 91 5% .125W	1	B8	A6
A2	R91	0758-0086	R-F 100 5% .125W	1	B7	B6
A2	R92	0698-4254	R-F 1K5% .125W F	1	B6	A6
A2	R93	0698-4254	R-F 1K5% .125W F	1	C6	A5
A2	R94	0698-0083	R-F 1.96K1% .125W	1	D7	B5
A2	R95	0757-0421	R-F 825 1% .125W	1	D8	B5
A2	R96	0757-0400	R-F 90.9 1% .125W	1	E7	B5
A2	R97	0698-4258	R-F 1.5K5% .125W	1	E7	A5
A2	R98	0698-4251	R-F 750 5% .125W	2	E5	C2
A2	R99	0698-4251	R-F 750 5% .125W	2	F3	B2
A2	R100	0760-0012	R-F 51 2% 1W MO	2	F4	D3
A2	R101	0760-0012	R-F 51 2% 1W MO	2	F4	A3
A2	R102	0698-4258	R-F 1.5K5% .125W	1	I9	C4
A2	R103	0698-4258	R-F 1.5K5% .125W	1	K9	C5
A2	R104	0698-5702	R-F 30 5% .125W	1	D7	B6
A2	R105	0698-5702	R-F 30 5% .125W	1	C6	A6
A2	R106	0698-5702	R-F 30 5% .125W	1	B5	A6
A2	R107	0683-0475	R-F 4.7 5% .25W	1	J4	C7
A2	R108	0683-0475	R-F 4.7 5% .25W	1	J4	C8
A2	R109	0683-4705	R-F 47 5% .25W	1	I3	C7
A2	R110	0683-4705	R-F 47 5% .25W	1	I7	C5
A2	R111	0698-4239	R-F 220 5% .125W	1	I4	D7
A2	R112	0698-4239	R-F 220 5% .125W	1	I6	D5
A2	*R113	*0698-6744	*R-F 20 5% .125W	1	K8	C4
A2	*R114	*	*	1	K1	B7
A2	S1	3101-0973	SW SLIDE DPDT			
A2	S2	3101-0973	SW SLIDE DPDT			

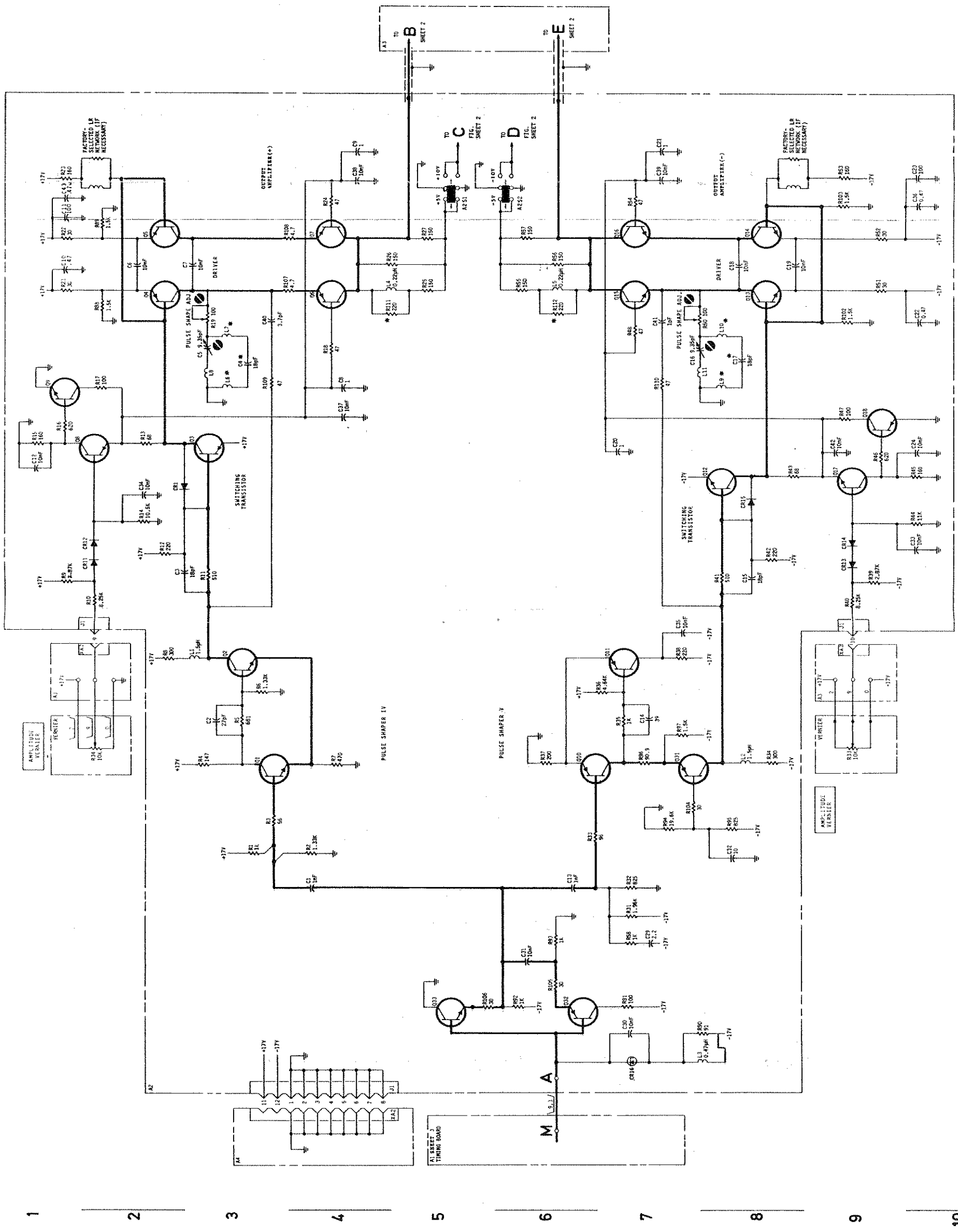

Figure 5-13 Circuit Diagram: Assemblies 2 and 3 Sheet 1 of 2

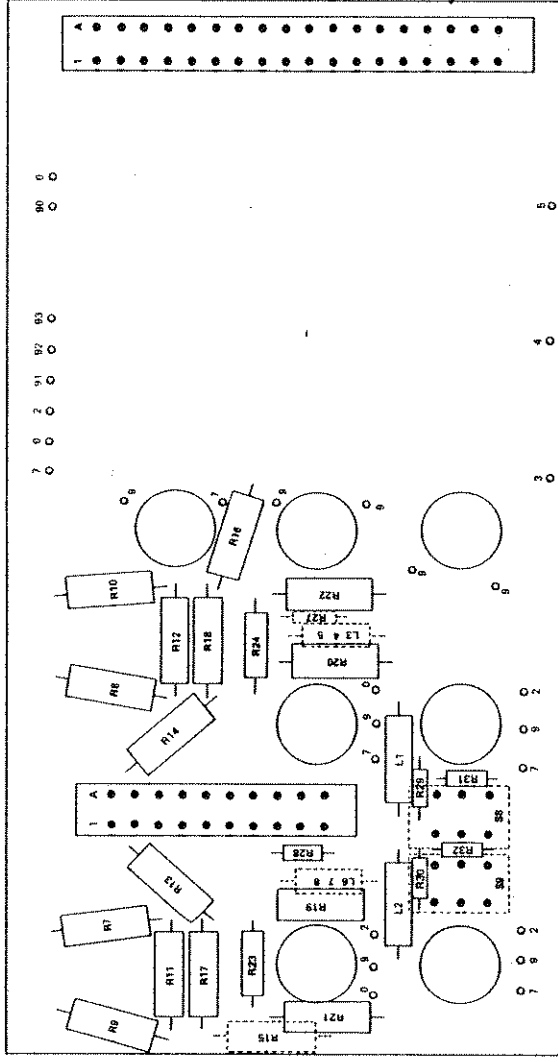

Figure 5-12 Component Layout: Assemblies 2 and 3

Table 5-5 Replaceable Parts: Assembly 3

REFERENCE DESIGNATOR	HP PART NUMBER	DESCRIPTION	CIRCUIT DIAGRAM SHEET NUMBER	GRID REFERENCE	COMPONENT LAYOUT
A3 17	0757-0799	R-F 121 1 1/2W			
A3 18	0757-0799	R-F 121 1 1/2W			
A3 L1	914C-0118	COIL-CHOKE 500UH			
A3 L2	914C-0118	COIL-CHOKE 500UH			
A3 L3	917C-0029	CORE FERRI BEAD			
A3 L4	917C-0029	CORE FERRI BEAD			
A3 L5	917C-0029	CORE FERRI BEAD			
A3 L6	917C-0029	CORE FERRI BEAD			
A3 L7	917C-0029	CORE FERRI BEAD			
A3 L8	917C-0029	CORE FERRI BEAD			
A3 R7	076C-0027	R-F 150 2X 1W MD			
A3 R8	076C-0027	R-F 150 2X 1W MD			
A3 R9	076C-0027	R-F 150 2X 1W MD			
A3 R10	076C-0027	R-F 150 2X 1W MD			
A3 R11	0757-0172	R-F 37.4 1 1/2W			
A3 R12	0757-0172	R-F 37.4 1 1/2W			
A3 R13	076C-0026	R-F 75 2X 1W MD			
A3 R14	076C-0026	R-F 75 2X 1W MD			
A3 R15	076C-0026	R-F 75 2X 1W MD			
A3 R16	076C-0026	R-F 75 2X 1W MD			
A3 R19	0761-0003	R-F 62 5X 1W MD			
A3 R20	0761-0003	R-F 62 5X 1W MD			
A3 R21	0761-0003	R-F 62 5X 1W MD			
A3 R22	0761-0003	R-F 62 5X 1W MD			
A3 R23	0757-0071	R-F 247.5 1 1/2W			
A3 R24	0757-0071	R-F 247.5 1 1/2W			
A3 R27	0698-4238	R-F 200 5X 1.25W			
A3 R28	0698-4238	R-F 200 5X 1.25W			
A3 R29	0698-4272	R-F 5.6K5% 1.25W			
A3 R30	0698-4272	R-F 5.6K5% 1.25W			
A3 P31	0698-4270	R-F 4.7K5% 1.25W			
A3 R32	0698-4270	R-F 4.7K5% 1.25W			
A3 S1	504C-1109	SLIDAY			
A3 S2	504C-1109	SLIDAY			
A3 S3	504C-1110	SLIDAY			
A3 S6	504C-1112	SLIDAY			
A3 S7	504C-1112	SLIDAY			
A3 S8	3101-1311	SW SLIDE DPDT			
A3 S9	3101-1311	SW SLIDE DPDT			

A B C D E F G H I J K L

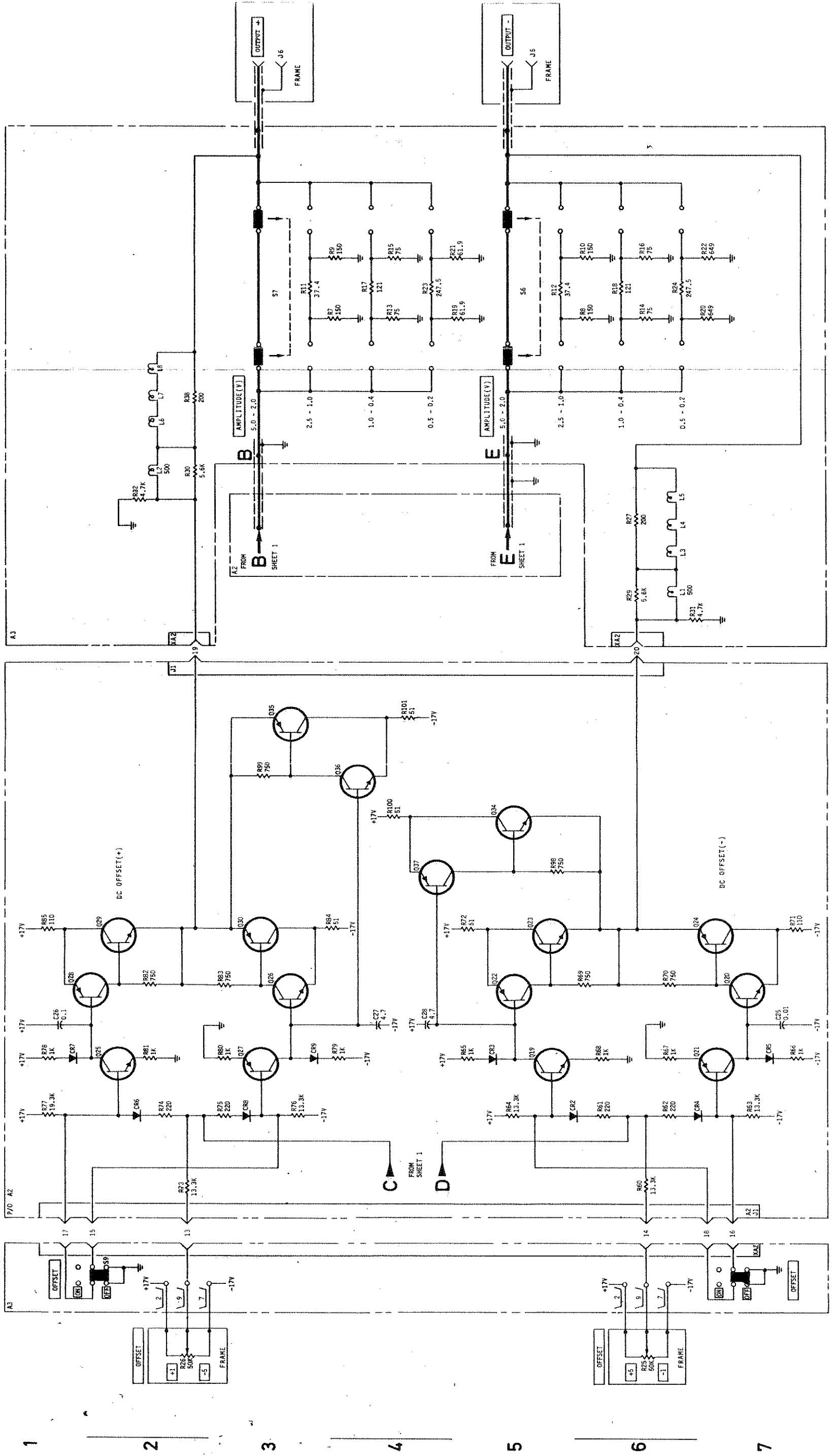

Figure 5-13 Circuit Diagram: Assemblies 2 and 3 Sheet 2 of 2

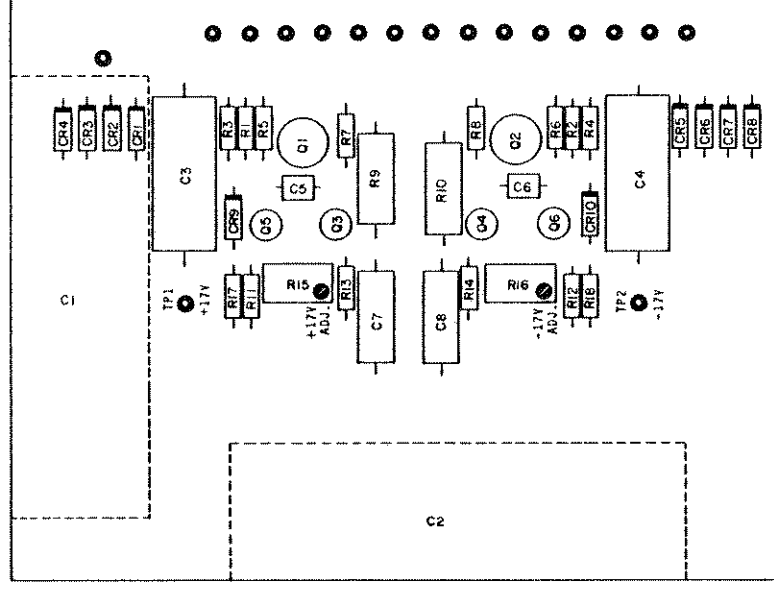

Figure 5-14 Component Layout: Assembly 4

REFERENCE DESIGNATOR	H/P PART NUMBER	DESCRIPTION	CIRCUIT DIAGRAM SHEET NUMBER	GRID REFERENCE	COMPONENT LAYOUT
A4 C1	0180-1784	C-F 100UF 40V			
A4 C2	0180-1784	C-F 100UF 40V			
A4 C3	0180-1050	C-F 40UF 50V			
A4 C4	0180-0390	C-F 4UF 50V			
A4 C5	0160-2930	C-F .1UF 100V			
A4 C6	0160-2930	C-F .1UF 100V			
A4 C7	0180-0228	C-F 22UF 15V			
A4 C8	0180-0228	C-F 22UF 15V			
A4 CR1	1901-0049	D10 SI 50V .75A			
A4 CR2	1901-0049	D10 SI 50V .75A			
A4 CR3	1901-0049	D10 SI 50V .75A			
A4 CR4	1901-0049	D10 SI 50V .75A			
A4 CR5	1901-0049	D10 SI 50V .75A			
A4 CR6	1901-0049	D10 SI 50V .75A			
A4 CR7	1901-0049	D10 SI 50V .75A			
A4 CR8	1901-0049	D10 SI 50V .75A			
A4 CR9	1902-0049	DI0 PKDN 5.19 V			
A4 CR10	1902-0049	DI0 BKDN 5.19 V			
A4 Q1	1854-0013	XSTR 2N2218A SI			
A4 Q2	1854-0013	XSTR 2N2218A SI			
A4 Q3	1854-0307	XSTR SI NPN			
A4 Q4	1854-0307	XSTR SI NPN			
A4 Q5	1854-0307	XSTR SI NPN			
A4 Q6	1854-0307	XSTR SI NPN			
A4 R1	0698-4265	R-F 3K52 .125W F			
A4 R2	0698-4265	R-F 3K52 .125W F			
A4 R3	0698-4271	R-F 5.1K52 .125W F			
A4 R4	0698-4271	R-F 5.1K52 .125W F			
A4 R5	0698-4276	R-F 8.2K52 .125W F			
A4 R6	0698-4276	R-F 8.2K52 .125W F			
A4 R7	0698-4261	R-F 2K52 .125W F			
A4 R8	0698-4261	R-F 2K52 .125W F			
A4 R9	0811-0929	R-F .51 5T 2M PW			
A4 R10	0811-0929	R-F .51 5T 2M PW			
A4 R11	0698-4261	R-F 2K52 .125W F			
A4 R12	0698-4261	R-F 2K52 .125W F			
A4 R13	0698-4262	R-F 2.2K52 .125W F			
A4 R14	0698-4262	R-F 2.2K52 .125W F			
A4 R15	2100-2741	R-VAR 470 2M CER			
A4 R16	2100-2741	R-VAR 470 2M CER			
A4 R17	0698-4257	R-F 1.3K52 .125W F			
A4 R18	0698-4257	R-F 1.3K52 .125W F			

Table 5-6 Replaceable Parts: Assembly 4

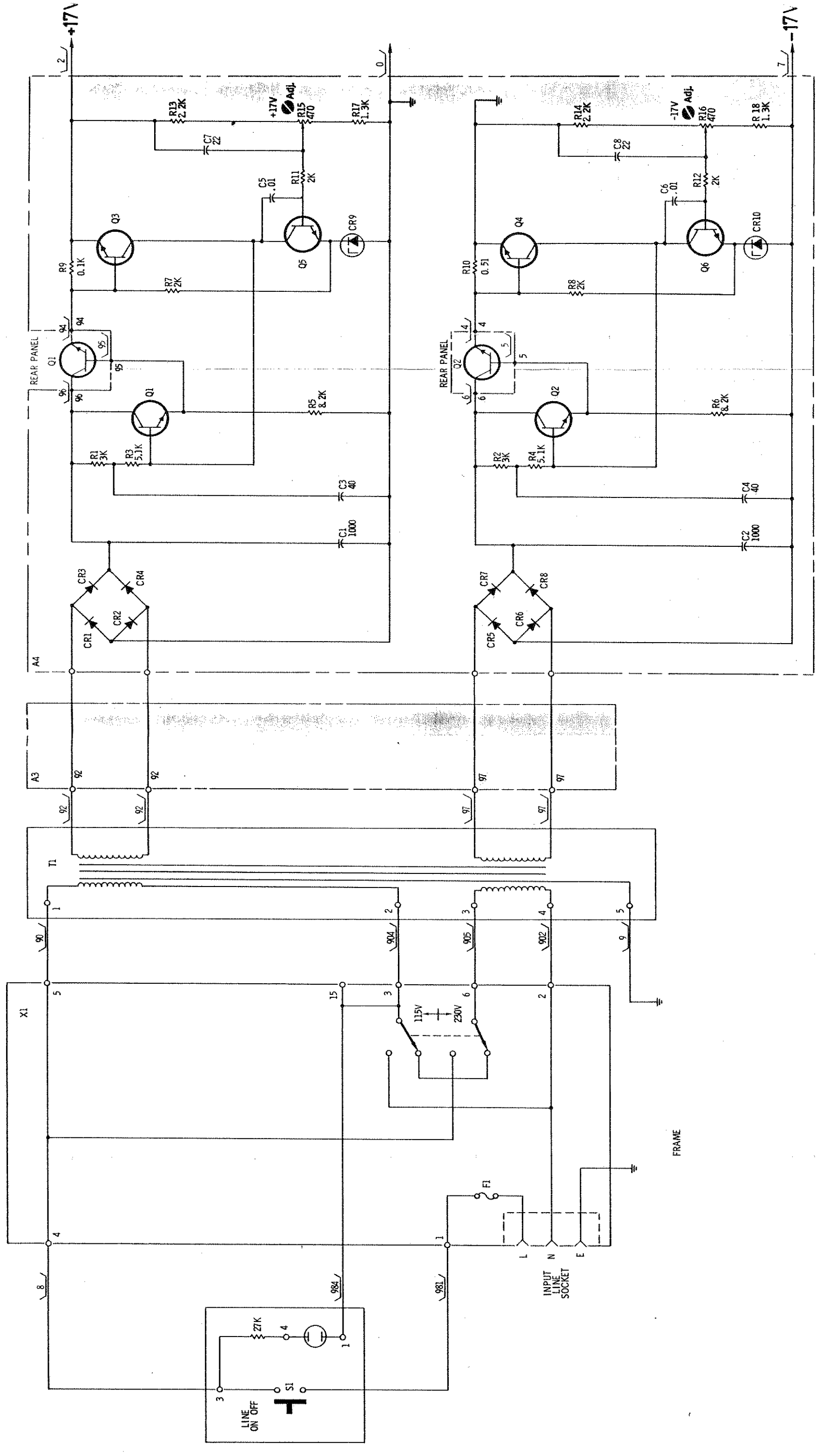

Figure 5-15 Circuit Diagram: Assembly 4 and Power Supplies



MANUAL CHANGES

MODEL 8013A

Manual Serials Prefixed: 1121G
Manual Printed: NOV 1971

Make all changes listed below as Errata. Check the following table for your instrument serial prefix and/or serial number and make listed change(s) to the manual:

Serial Prefix or Number	Make Changes	Serial Prefix or Number	Make Changes
1131A, 1148A	1		
1230A	1, 2		

Δ ERRATA

Table 5-2,

Add MP1: HP Part No. 1460-1300; TILT STAND.

Table 5-3,

A1C5: Change to HP Part No. 0140-0203, C-F 30PF 5%.

A1C11: Change to HP Part No. 0160-3650, C-F .018UF 10% 50V.

A1R4: Change to HP Part No. 0757-0895, R-F 63 2% 1/8W.

A1R7, A1R22: Change to HP Part No. 0757-0954, R-F 18K 2% 1/8W.

A1R12, A1R88: Change to HP Part No. 0757-0908, R-F 220 2% 1/8W.

A1R14, A1R133: Change to HP Part No. 0757-0927, R-F 1.3K 2% 1/8W.

A1R16, A1R45, A1R121, A1R134, A1R139: Change to HP Part No. 0757-0907, R-F 200 2% 1/8W.

A1R17, A1R73: Change to HP Part No. 0757-0894, R-F 56 2% 1/8W.

A1R18, A1R27, A1R28, A1R112, A1R116, A1R117: Change to HP Part No. 0757-0948, R-F 10K 2% 1/8W.

A1R19, A1R127: Change to HP Part No. 0757-0898, R-F 82 2% 1/8W.

A1R20, A1R82, A1R106, A1R109: Change to HP Part No. 0757-0910, R-F 270 2% 1/8W.

A1R21: Change to HP Part No. 0757-0925, R-F 1.1K 2% 1/8W.

A1R23: Change to HP Part No. 0757-0931, R-F 2K 2% 1/8W.

A1R24: Change to HP Part No. 0757-0929, R-F 2K 2% 1/8W.

Table 5-2 (cont'd)

A1R25, A1R145: Change to HP Part No. 0757-0906, R-F 180 2% 1/8W.

A1R26, A1R52, A1R53: Change to HP Part No. 0757-0949, R-F 11K 2% 1/8W.

A1R30: Change to HP Part No. 0757-0937, R-F 3.6K 2% 1/8W.

A1R33: Change to HP Part No. 0757-0903, R-F 130 2% 1/8W.

A1R35: Change to HP Part No. 0757-0400, R-F 90.9 1% 1/8W.

A1R39, A1R48, A1R49, A1R50, A1R75, A1R76, A1R99, A1R100, A1R101, A1R132, A1R163: Change to HP Part No. 0757-0941, R-F 5.1K 2% 1/8W.

A1R40, A1R130: Change to HP Part No. 0757-0420, R-F 750 1% 1/8W.

A1R51: Change to HP Part No. 0757-0944, R-F 6.8K 2% 1/8W.

A1R54, A1R55, A1R138, A1R161: Change to HP Part No. 0757-0926, R-F 1.2K 2% 1/8W.

A1R59: Change to HP Part No. 0757-0930, R-F 1.8K 2% 1/8W.

A1R60, A1R61: Change to HP Part No. 0757-0935, R-F 3K 2% 1/8W.

A1R62: Change to HP Part No. 0698-7029, R-F 39 2% 1/8W.

A1R65, A1R85, A1R113: Change to HP Part No. 0757-0930, R-F 1.8K 2% 1/8W.

A1R66: Change to HP Part No. 0757-0953, R-F 16K 2% 1/8W.

A1R70, A1R71, A1R72, A1R102, A1R103, A1R119: Change to HP Part No. 0698-4264, R-F 2.7K 2% 1/8

July 24, 1972

Δ = Latest additions to this change sheet.

For the latest issue, see all prior change sheets for this manual.

Supplement A for
08013-90001

△ ERRATA (Cont'd)

Table 5-3 (cont'd)

A1R73, A1R74, A1R91, A1R92, A1R93:
Change to HP Part No. 0757-0957, R-F 24K
2% 1/8W.

A1R78, A1R80, A1R105, A1R108: Change to HP
Part No. 0757-0390, R-F 36.5 1% 1/8W.

A1R81, A1R107: Change to HP Part No. 0757-
0928, R-F 1.5K 2% 1/8W.

A1R84: Change to HP Part No. 0757-0076, R-F
166K 1% 1W.

A1R86, A1R87: Change to HP Part No. 0757-
0904, R-F 150 2% 1/8W.

A1R89: Change to HP Part No. 0757-0389, R-F
33.2 1% 1/8W.

A1R125, A1R143, A1R168: Change to HP
Part No. 0757-0940, R-F 4700 2% 1/8W.

A1R128: Change to HP Part No. 0757-0912,
R-F 330 2% 1/8W.

A1R135: Change to HP Part No. 0757-0939, R-F
4.3K 2% 1/8W.

A1R137: Change to HP Part No. 0757-0932,
R-F 2.2K 2% 1/8W.

A1R141, A1R174: Change to HP Part No. 0757-
0911, R-F 300 2% 1/8W.

A1R141, A1R183: Change to HP Part No. 0698-
6994, R-F 30 2% 1/8W.

A1R150: Change to HP Part No. 0698-6802,
R-F 100 2% 1/8W.

A1R158: Change to HP Part No. 0757-0936,
R-F 3.3K 2% 1/8W.

A1R159: Change to HP Part No. 0757-0384,
R-F 20 1% 1/8W.

A1R169: Change to HP Part No. 0757-0923,
R-F 910 2% 1/8W.

A1R174: Change to HP Part No. 0698-4242,
R-F 300 5% 1/8W.

A1R175: Change to HP Part No. 0757-0943,
R-F 6.2K 2% 1/8W.

A1R176: Change to HP Part No. 0757-0909,
R-F 240 2% 1/8W.

Table 5-4

A2R3, A2R33: Change to HP Part No. 0757-
0894, R-F 56 2% 1/8W.

A2R8, A2R34: Change to HP Part No. 0757-
0911, R-F 300 2% 1/8W.

Table 5-4 (cont'd)

A2R11, A2R41: Change to HP Part No.
0757-0917, R-F 510 2% 1/8W.

A2R12, A2R111, A2R112: Change to HP
Part No. 0757-0908, R-F 220 2% 1/8W.

A2R15, A2R23, A2R45, A2R53: Change to
HP Part No. 0757-0905, R-F 160 2% 1/8W.

A2R16, A2R46: Change to HP Part No.
0757-0919, R-F 620 2% 1/8W.

A2R88, A2R89, A2R97, A2R102, A2R103
Change to HP Part No. 0757-0928, R-F
1.5K 2% 1/8W.

A2R90: Change to HP Part No. 0757-0400,
R-F 90.9 1% 1/8W.

Table 5-5,

A3R27, A3R28: Change to HP Part No.
0747-0907, R-F 200 2% 1/8W.

Table 5-6,

A4R1, A4R2: Change to HP Part No. 0757-
0935, R-F 3K 2% 1/8W.

A4R3, A4R4: Change to HP Part No. 0757-
0941, R-F 5.1K 2% 1/8W.

A4R5, A4R6: Change to HP Part No. 0757-
0946, R-F 8.2K 2% 1/8W.

A4R7, A4R8, A4R11, A4R12: Change to
Part No. 0757-0931, R-F 2K 2% 1/8W.

A4R13, A4R14: Change to HP Part No.
0757-0932, R-F 2.2K 2% 1/8W.

A4R17, A4R18: Change to HP Part No.
0757-0927, R-F 1.3K 2% 1/8W.

Figure 5-11, Sheet 1, Page 5-25,

C11: Change value to .018UF.
R30: Change value to 3.6K.
R33: Change value to 130.
R59: Change value to 1.8K.

Figure 5-11, Sheet 2, Page 5-27,

R15, R16: Change value to 121.
R27: Change value to 17.8.
R78, R80: Change value to 36.5.

Figure 5-11, Sheet 3, Page 5-29,

R89: Change value to 33.2.
R105, R108: Change value to 36.5.

Figure 5-11, Sheet 4, Page 5-31,

R150: Change value to 10.
R-174: Change value to 300.

CHANGE 1

Page 5-6, Table 5-2,

Add F1: HP Part No. 2110-0007; FUSE 1 AMP
SLOW-BLOW 250V (115V LINE VOLTAGE).
Add F1: HP Part No. 2110-0202; FUSE 0.5 AMP
SLOW-BLOW 250V (230V LINE VOLTAGE).

Page 5-6,

Add Table 5-2a.

Page 5-23, Table 5-3,

A1C11: Change to HP Part No. 0160-3650;
C-F .018 UF 50V.
A1R150: Change to HP Part No. 0698-6802;
R-F 10 5% .125W.
A1R174: Change to HP Part No. 0698-4242;
R-F 300 5% .125W.

Table 5-2a. Miscellaneous Replaceable Parts: FRAME

HP Part No.	DESCRIPTION
0370-1005	KNOB, JADE-GRAY (OFFSET)
0370-2048	KNOB, JADE-GRAY (VERNIER)
5000-8867	XFMR COVER
5040-0445	FOOT, BOTTOM
5040-0447	FOOT, REAR (LONG)
00180-61103	TRANSISTOR HEAT SINK
08012-10201	REAR PANEL
08012-74101	COVER ASSEMBLY
08012-74401	CABINET ASSEMBLY
08013-10201	FRONT PANEL
08013-10203	SUB PANEL
8120-1545	POWER CORD

Δ CHANGE 2

Table 5-2,

T1: Change to HP Part No. 9100-
3255, XFMR PWR.

Table 5-3,

A1R59: Change to HP Part No. 0757-
0929, R-F 1.6K 2% 1/8W.
Figure 5-11, Sheet 1, Page 5-25,
R59: Change value to 1600.