

## About this Manual

We've added this manual to the Agilent website in an effort to help you support your product. This manual is the best copy we could find; it may be incomplete or contain dated information. If we find a more recent copy in the future, we will add it to the Agilent website.

## Support for Your Product

Agilent no longer sells or supports this product. Our service centers may be able to perform calibration if no repair parts are needed, but no other support from Agilent is available. You will find any other available product information on the Agilent Test & Measurement website, [www.tm.agilent.com](http://www.tm.agilent.com).

## HP References in this Manual

This manual may contain references to HP or Hewlett-Packard. Please note that Hewlett-Packard's former test and measurement, semiconductor products and chemical analysis businesses are now part of Agilent Technologies. We have made no changes to this manual copy. In other documentation, to reduce potential confusion, the only change to product numbers and names has been in the company name prefix: where a product number/name was HP XXXX the current name/number is now Agilent XXXX. For example, model number HP8648A is now model number Agilent 8648A.

# Installation and Verification Manual

**HP 70907A/B**

**External Mixer Interface**



HP Part No. 70907-90029  
Printed in USA September 1999

**Notice**

The information contained in this document is subject to change without notice.

Hewlett-Packard makes no warranty of any kind with regard to this material, including, but not limited to, the implied warranties of merchantability and fitness for a particular purpose. Hewlett-Packard shall not be liable for errors contained herein or for incidental or consequential damages in connection with the furnishing, performance, or use of this material.

**Restricted Rights Legend.**

Use, duplication, or disclosure by the U.S. Government is subject to restrictions as set forth in subparagraph (c) (1) (ii) of the Rights in Technical Data and Computer Software clause at DFARS 252.227-7013 for DOD agencies, and subparagraphs (c) (1) and (c) (2) of the Commercial Computer Software Restricted Rights clause at FAR 52.227-19 for other agencies.

©Copyright Hewlett-Packard Company 1990, 1999

All Rights Reserved. Reproduction, adaptation, or translation without prior written permission is prohibited, except as allowed under the copyright laws.  
1400 Fountaingrove Parkway, Santa Rosa, CA 95403-1799, USA

---

## Certification

Hewlett-Packard Company certifies that this product met its published specifications at the time of shipment from the factory. Hewlett-Packard further certifies that its calibration measurements are traceable to the United States National Institute of Standards and Technology, to the extent allowed by the Institute's calibration facility, and to the calibration facilities of other International Standards Organization members.

---

## Warranty

This Hewlett-Packard instrument product is warranted against defects in material and workmanship for a period of one year from date of shipment. During the warranty period, Hewlett-Packard Company will, at its option, either repair or replace products which prove to be defective.

For warranty service or repair, this product must be returned to a service facility designated by Hewlett-Packard. Buyer shall prepay shipping charges to Hewlett-Packard and Hewlett-Packard shall pay shipping charges to return the product to Buyer. However, Buyer shall pay all shipping charges, duties, and taxes for products returned to Hewlett-Packard from another country.

Hewlett-Packard warrants that its software and firmware designated by Hewlett-Packard for use with an instrument will execute its programming instructions when properly installed on that instrument. Hewlett-Packard does not warrant that the operation of the instrument, or software, or firmware will be uninterrupted or error-free.

### LIMITATION OF WARRANTY

The foregoing warranty shall not apply to defects resulting from improper or inadequate maintenance by Buyer, Buyer-supplied software or interfacing, unauthorized modification or misuse, operation outside of the environmental specifications for the product, or improper site preparation or maintenance.

NO OTHER WARRANTY IS EXPRESSED OR IMPLIED. HEWLETT-PACKARD SPECIFICALLY DISCLAIMS THE IMPLIED WARRANTIES OF MERCHANTABILITY AND FITNESS FOR A PARTICULAR PURPOSE.

### EXCLUSIVE REMEDIES

THE REMEDIES PROVIDED HEREIN ARE BUYER'S SOLE AND EXCLUSIVE REMEDIES. HEWLETT-PACKARD SHALL NOT BE LIABLE FOR ANY DIRECT, INDIRECT, SPECIAL, INCIDENTAL, OR CONSEQUENTIAL DAMAGES, WHETHER BASED ON CONTRACT, TORT, OR ANY OTHER LEGAL THEORY.

---

## Assistance

*Product maintenance agreements and other customer assistance agreements are available for Hewlett-Packard products.*

*For any assistance, contact your nearest Hewlett-Packard Sales and Service Office.*

---

## Safety Symbols

The following safety symbols are used throughout this manual. Familiarize yourself with each of the symbols and its meaning before operating this instrument.

---

**CAUTION**     The *CAUTION* sign denotes a hazard. It calls attention to a procedure which, if not correctly performed or adhered to, could result in damage to or destruction of the product or the user's work. Do not proceed beyond a *CAUTION* sign until the indicated conditions are fully understood and met.

---

**WARNING**     The *WARNING* sign denotes a hazard. It calls attention to a procedure which, if not correctly performed or adhered to, could result in injury to the user. Do not proceed beyond a *WARNING* sign until the indicated conditions are fully understood and met.

---

**DANGER**     The *DANGER* sign denotes an imminent hazard to people. It warns the reader of a procedure which, if not correctly performed or adhered to, could result in injury or loss of life. Do not proceed beyond a *DANGER* sign until the indicated conditions are fully understood and met.

---

---

## General Safety Considerations

---

- WARNING**
- The instructions in this document are for use by qualified personnel only. To avoid electrical shock, do not perform any servicing unless you are qualified to do so.
  - The opening of covers or removal of parts is likely to expose dangerous voltages. Disconnect the instrument from all voltage sources while it is being opened.
  - The power cord is connected to internal capacitors that may remain live for five seconds after disconnecting the plug from its power supply.
  - This is a Safety Class 1 Product (provided with a protective earthing ground incorporated in the power cord). The mains plug shall only be inserted in a socket outlet provided with a protective earth contact. Any interruption of the protective conductor inside or outside of the instrument is likely to make the instrument dangerous. Intentional interruption is prohibited.
  - For continued protection against fire hazard, replace fuse only with same type and ratings, (type nA/nV). The use of other fuses or materials is prohibited.
- 

- WARNING**
- Before this instrument is switched on, make sure it has been properly grounded through the protective conductor of the ac power cable to a socket outlet provided with protective earth contact.  
  
Any interruption of the protective (grounding) conductor, inside or outside the instrument, or disconnection of the protective earth terminal can result in personal injury.
  - Before this instrument is switched on, make sure its primary power circuitry has been adapted to the voltage of the ac power source.  
  
Failure to set the ac power input to the correct voltage could cause damage to the instrument when the ac power cable is plugged in.
-



# Contents

---

## 1. General Information

Manual Conventions . . . . .	1-1
Module Description . . . . .	1-2
Firmware Compatibility . . . . .	1-2
HP 70907A Requirements . . . . .	1-2
HP 70907B Requirements . . . . .	1-2
LO Firmware Version 860203 or Earlier . . . . .	1-2
LO Firmware Version From 861015 to 880901 . . . . .	1-2
Module Options . . . . .	1-3
HP 70907A . . . . .	1-3
HP 70907B . . . . .	1-3
Safety Considerations . . . . .	1-3
Modules Covered by Manual . . . . .	1-4
Serial Numbers . . . . .	1-4
Initial Inspection . . . . .	1-4
Accessories . . . . .	1-5
Front- and Rear-Panel Features . . . . .	1-6
Status and Error LEDs . . . . .	1-6
Front-Panel Inputs and Outputs . . . . .	1-6
Module Latch . . . . .	1-6
Rear-Panel Inputs and Outputs . . . . .	1-8
Electrostatic Discharge Information . . . . .	1-10
Reducing ESD Damage . . . . .	1-10
PC Board Assemblies and Electronic Components . . . . .	1-10
Test Equipment . . . . .	1-11
Static-Safe Accessories . . . . .	1-12
Returning Instruments for Service . . . . .	1-13
Sales and Service Offices . . . . .	1-15

## 2. Installation

Addressing the Module . . . . .	2-2
Determining the HP-MSIB Address . . . . .	2-2
Setting the HP-MSIB Address Switches . . . . .	2-3
Installing the Module in the Mainframe . . . . .	2-4
Connecting the Rear-Panel Cables . . . . .	2-5
Checking Module Operation . . . . .	2-7
Examining the Front-Panel LEDs . . . . .	2-7
Checking for Error Messages . . . . .	2-7



<b>3. Specifications</b>	
HP 70907A Module Specifications and Characteristics . . . . .	3-2
Front-Panel Inputs and Outputs . . . . .	3-2
Rear-Panel Inputs and Outputs . . . . .	3-2
LO IN . . . . .	3-2
LO OUT . . . . .	3-2
TUNE SPAN . . . . .	3-2
321.4 MHz OUT . . . . .	3-2
300 MHz OUT . . . . .	3-2
300 MHz IN . . . . .	3-2
21.4 MHz OUT . . . . .	3-3
21.4 MHz IN . . . . .	3-3
General Specifications and Characteristics . . . . .	3-3
HP 70907B Module Specifications and Characteristics . . . . .	3-4
Front-Panel Inputs and Outputs . . . . .	3-4
Rear-Panel Inputs and Outputs . . . . .	3-4
LO IN . . . . .	3-4
LO OUT . . . . .	3-4
TUNE SPAN . . . . .	3-4
321.4 MHz OUT . . . . .	3-4
300 MHz OUT . . . . .	3-4
300 MHz IN . . . . .	3-4
21.4 MHz OUT . . . . .	3-5
21.4 MHz IN . . . . .	3-5
General Specifications and Characteristics . . . . .	3-5
<b>4. Verification</b>	
<b>5. Troubleshooting</b>	
Front-Panel LEDs . . . . .	5-1
Error Messages . . . . .	5-1
Usage/Operating Errors . . . . .	5-2
Hardware Warning Errors . . . . .	5-2
Hardware Broken Errors . . . . .	5-2

**Index**

## Figures

---

1-1. Typical Serial Number Label . . . . .	1-4
1-2. HP 70907A and HP 70907B Front-Panel Features . . . . .	1-7
1-3. HP 70907A/B Rear-Panel Features . . . . .	1-9
1-4. Static-Safe Work Station . . . . .	1-10
1-5. Packaging Materials for Modules . . . . .	1-14
2-1. Address Map for an EMIM in an HP 71210C System . . . . .	2-2
2-2. HP 70907A/B Address Switches . . . . .	2-3
2-3. Module Installation in Mainframe . . . . .	2-4
2-4. Rear-Panel Cabling for an EMIM in an HP 71210C System . . . . .	2-6

## Tables

---

1-1. Accessories Shipped when the Module is Ordered Separately . . . . .	1-5
1-2. Static-Safe Accessories . . . . .	1-12
1-3. Hewlett-Packard Sales and Service Offices . . . . .	1-16
2-1. Decimal Equivalents of Row and Column Address Switches . . . . .	2-3



## General Information

---

The *HP 70907A/B External Mixer Interface Installation and Verification Manual* contains information needed to install the HP 70907A/B External Mixer Interface module (EMIM) into an HP 70000 Series system and then check basic module operation. For information on installing and verifying HP 70000 Modular Measurement Systems, refer to the Installation and Verification Manual for the system master (for example, HP 70900B Local Oscillator).

This manual contains the following five chapters:

- Chapter 1, “General Information,” describes the module and its accessories, gives electrostatic discharge and packaging information, and lists Hewlett-Packard Sales and Service Offices.
- Chapter 2, “Installation,” provides information for configuring and installing the module in an HP 70000 Modular Measurement System.
- Chapter 3, “Specifications,” lists module specifications and characteristics that apply to the HP 70907A/B. (System specifications that will be modified when the HP 70907A/B is added to a system are documented in the Installation and Verification Manual for the system master.)
- Chapter 4, “Verification,” contains information about the tests needed to verify the specifications.
- Chapter 5, “Troubleshooting,” explains the most probable causes of the front-panel status and error LEDs’ lighting, and lists the error codes that can be generated by the HP 70907A/B module.

---

## Manual Conventions

The following descriptions are used throughout this manual:

Keys physically on an instrument are represented in the following way:

Key ..... **KEY**

Softkeys, keys defined by software or firmware, are represented in the following way:

Softkey ..... **softkey**

Text that appears on the display screen is represented in the following way:

Screen text ..... **screen text**

---

## Module Description

Both the HP 70907A and the HP 70907B External Mixer Interface modules (EMIMs) are 1/8-width modules designed to plug into HP 70000 Modular Measurement System mainframes. The modules are slaves controlled by an HP 70000 Modular Measurement System master element such as the HP 70900B Local Oscillator.

Both EMIMs allow HP 70000 Modular Measurement systems to operate with the HP 11970 Series of external mixers. The HP 70907B also allows operation with the HP 11974 Series of preselected millimeter-wave front ends. At turn on, the system master sets the HP 70907B default state to **PRESEL ON**, resulting in a sweeptime that is slow enough for the internal preselector-magnetics in an HP 11974 Series front end. If the HP 70907B is used with an external mixer from the HP 11970 Series, **PRESEL OFF** can be selected to tell the system master to sweep faster.

---

## Firmware Compatibility

### HP 70907A Requirements

For the HP 70907A to function properly in an HP 70000 Modular Measurement System, the HP 70900 local oscillator (LO) must have a firmware version of 860203 or later. If the LO firmware version is 850730, a controller board/firmware-upgrade kit can be ordered (HP part number 70900-60137).

### HP 70907B Requirements

For the HP 70907B to function properly in an HP 70000 Modular Measurement System, the HP 70900 local oscillator (LO) must have a firmware version of 890606 or later.

#### LO Firmware Version 860203 or Earlier

If the HP 70900 local oscillator firmware version is 860203 or earlier, an LO controller board/firmware-upgrade kit (HP part number 70900-60137) can be ordered. If HP 70907B Option 098 is ordered, this controller board/firmware-upgrade kit is included.

#### LO Firmware Version From 861015 to 880901

If the HP 70900 local oscillator firmware version is from 861015 to 880901, an LO firmware-upgrade kit (HP part number 70900-60138) can be ordered. If HP 70907B Option 099 is ordered, this firmware-upgrade kit is included.

---

## Module Options

### HP 70907A

The HP 70907A has the following module options:

- Option 910** This option adds another *HP 70907A/B External Mixer Interface Installation and Verification Manual*.
- Option 915** This option adds the module service documentation and module verification software.

### HP 70907B

The HP 70907B has the following module options:

- Option 098** This option adds the LO controller board/firmware-upgrade kit. Refer to “Firmware Compatibility” above for information about which LO firmware versions are needed for compatibility with the 70907B module.
- Option 099** This option adds the LO firmware-upgrade kit. Refer to “Firmware Compatibility” above for information about which LO firmware versions are needed for compatibility with the 70907B module.
- Option 910** This option adds another *HP 70907A/B External Mixer Interface Installation and Verification Manual*.
- Option 915** This option adds the module service documentation and module verification software.

---

## Safety Considerations

Before operating this module, familiarize yourself with any safety markings on the module and the safety instructions in this manual. This module has been manufactured and tested according to international safety standards. However, to ensure safe operation of the module and personal safety of the user and service personnel, the cautions and warnings in this manual must be followed. Refer to the summary of safety considerations at the front of this manual.

---

## Modules Covered by Manual

### Serial Numbers

Attached to the front frame of the module is a serial-number label. The serial number is in two parts. The first four digits and letter are the serial number prefix; the last five digits are the suffix. See Figure 1-1. The prefix is the same for all identical modules; it only changes when a change is made to the module. The suffix, however, is assigned sequentially and is different for each module. The contents of this manual apply to modules with the serial number prefixes listed under “Serial Numbers” on the manual title page.



**Figure 1-1. Typical Serial Number Label**

---

### Initial Inspection

Inspect the shipping container for damage. If the shipping container or cushioning material is damaged, it should be kept until the contents of the shipment have been checked for completeness and the module has been checked mechanically and electrically. Refer to “Accessories” below to find out what is shipped with the HP 70907A/B.

If the shipping contents are not complete, or the module does not pass the verification procedures (refer to Chapter 4), notify the nearest Hewlett-Packard office. If the shipping container is damaged, or the cushioning material shows signs of stress, notify the carrier as well as the Hewlett-Packard office. Keep the shipping materials for the carrier’s inspection. The Hewlett-Packard office will arrange for repair or replacement without waiting for claim settlement.

---

## Accessories

The HP 70907A/B External Mixer Interface module may be ordered separately or as part of a preconfigured HP 70000 Modular Measurement System. When ordered as part of a preconfigured system, the modules come with cables that match the factory configuration. When the modules are ordered separately, they are shipped with a group of accessories (refer to Table 1-1) that allow the most common system configurations.

The accessories in this table are those available at the print date of this manual. For a list of available system cables, refer to the Installation and Verification Manual for the system master.

The information in the “L/R” column of the table refers to signal flow “out” to “in” as viewed from the front panel. For example, if the signal source is to the left of the signal destination when viewed from the front panel, a “L to R” cable is needed. Bends in the semirigid cables make this distinction necessary.

**Table 1-1. Accessories Shipped when the Module is Ordered Separately**

Accessory	1/8-Width Spans	L/R	Quantity Shipped	HP Part Number
Semirigid coax LO cable, SMA (m) to SMA (m)	1	L to R	1	5021-5448
Flexible coax LO cable, SMA (m) to SMA (m), 52 cm (20 in)	n/a	n/a	1	5061-9038
Flexible coax cable, SMB (f) to SMB (f)	1	n/a	3	5061-9015
Flexible coax cable, SMB (f) to SMB (f)	3	n/a	1	5061-9017
Flexible coax cable, SMB (f) to SMB (f)	7	n/a	1	5061-9021



---

## Front- and Rear-Panel Features

Figures 1-2 and 1-3 show the HP 70907A/B front- and rear-panel features.

### Status and Error LEDs

Both of the front-panel LEDs flash on, then off again, during the module's self-test. Listed below are the other reasons for each LED to light. For troubleshooting information, refer to Chapter 5.

**ACT** The ACT (active) LED lights when the module has an active keyboard link to an HP 70000 Modular Measurement System master and is being activated by that master. If there is no display in the system, the ACT LED will not light even if the previous requirements are met.

**ERR** The ERR (error) LED lights when an error condition exists.

### Front-Panel Inputs and Outputs

**PRESEL TUNE/SPAN** This BNC (f) connector is only present in HP 70907B modules. This connector provides a dc voltage which drives the preselector in the HP 11974 Series external mixer.

**MIXER BIAS OUT**  
or **MIXER BIAS** This SMA female connector provides the bias output for external mixers that require bias.

**LO OUTPUT** This SMA female connector provides the LO signal required by the external mixer.

**IF INPUT** This SMA female connector receives the input from the IF port of the external mixer.

### Module Latch

When the module is being installed in or removed from an HP 70000 Modular Measurement System mainframe, an 8 mm hex-ball driver is used to turn the module latch.

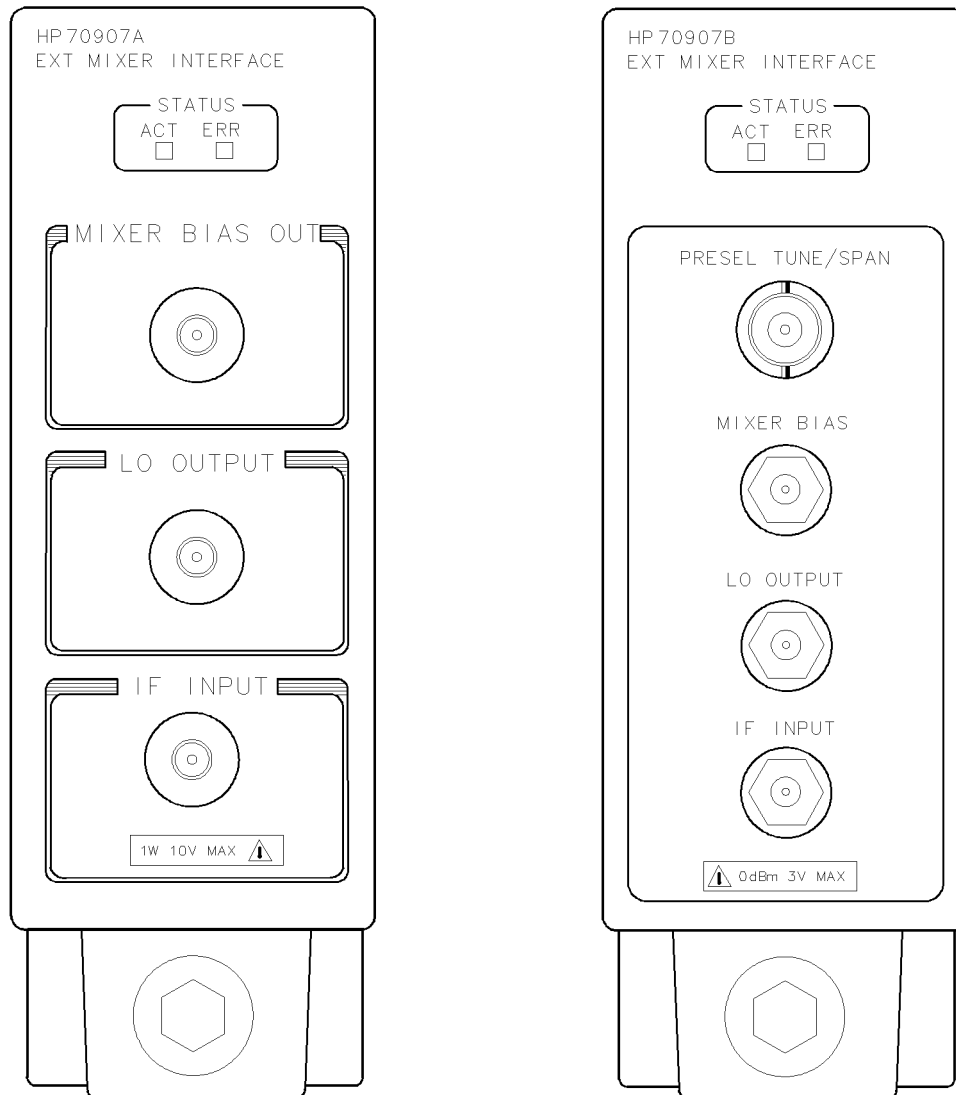

**Figure 1-2. HP 70907A and HP 70907B Front-Panel Features**

## Rear-Panel Inputs and Outputs

LO IN	This SMA female connector is normally connected to the LO OUT on the HP 70900 local oscillator.
LO OUT	This SMA female connector is normally terminated in 50Ω.
TUNE SPAN	This SMB male connector is normally connected to the TUNE SPAN on the HP 70900 local oscillator.
321.4 MHz OUT	This SMB male connector supplies an auxiliary IF output. This connector is not normally used.
300 MHz OUT	This SMB male connector is for use with system configurations using additional front-end modules.
300 MHz IN	This SMB male connector is normally connected to the 300 MHz OUT on the HP 70900 local oscillator.
21.4 MHz OUT	This SMB male connector normally connects to the 21.4 MHz IN on the IF section.
21.4 MHz IN	This SMB male connector is for use with system configurations using additional front-end modules.
Mainframe/Module Interconnect	This multiple-pin connector plugs into the mainframe and provides the power supplies and Hewlett-Packard Modular System Interface Bus (HP-MSIB) for the module.

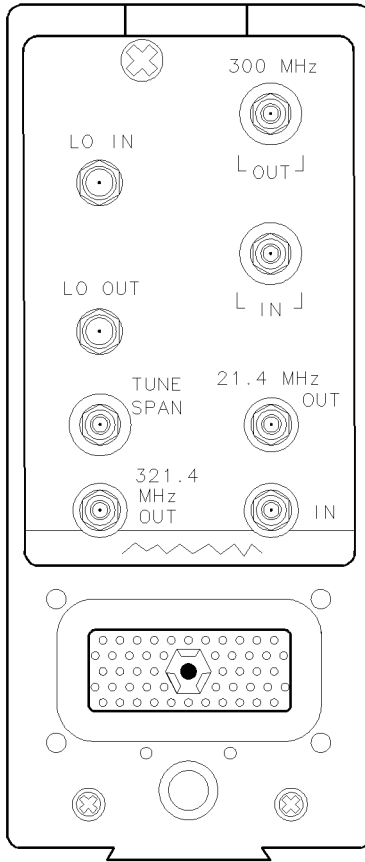

**Figure 1-3. HP 70907A/B Rear-Panel Features**

---

## Electrostatic Discharge Information

Electrostatic discharge (ESD) can damage or destroy electronic components. Therefore, all work performed on assemblies consisting of electronic components should be done at a static-safe work station.

Figure 1-4 shows an example of a static-safe work station. Two types of ESD protection are shown: (a) conductive table mat and wrist strap combination, and (b) conductive floor mat and heel strap combination. The two types must be used together to ensure adequate ESD protection. Refer to Table 1-2 for a list of static-safe accessories and their part numbers.

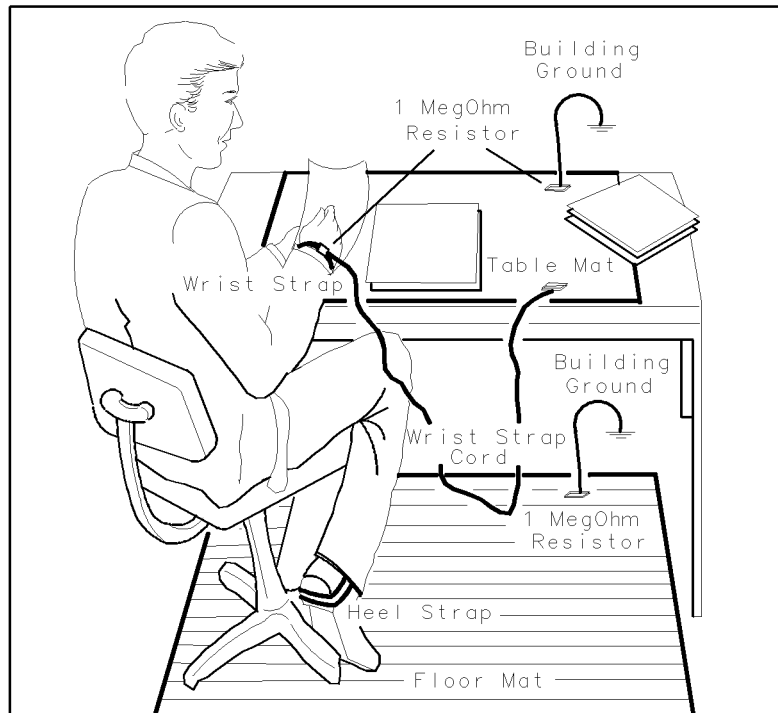

**Figure 1-4. Static-Safe Work Station**

### Reducing ESD Damage

Below are suggestions that may help reduce the amount of ESD damage that occurs during testing and servicing instruments.

#### PC Board Assemblies and Electronic Components

- Handle these items at a static-safe work station.
- Store or transport these items in static-shielding containers.

---

**Caution**

Do not use erasers to clean the edge-connector contacts. Erasers generate static electricity and degrade the electrical quality of the contacts by removing the thin gold plating.

Do not use paper of any kind to clean the edge-connector contacts. Paper or lint particles left on the contact surface can cause intermittent electrical connections.

Do not touch the edge-connector contacts or trace surfaces with bare hands. Always handle board assemblies by the edges.

---

PC board assembly edge-connector contacts may be cleaned by using a lint-free cloth with a solution of 80% electronics-grade isopropyl alcohol and 20% deionized water. This procedure should be performed at a static-safe work station.

**Test Equipment**

- Before connecting any coaxial cable to an instrument connector for the first time each day, *momentarily* short the center and outer conductors of the cable together.
- Personnel should be grounded with a resistor-isolated wrist strap before touching the center pin of any connector and before removing any assembly from the instrument.
- Be sure that all instruments are properly earth-grounded to prevent buildup of static charge.

## Static-Safe Accessories

**Table 1-2. Static-Safe Accessories**

Accessory	Description	HP Part Number
Static-control mat and ground wire	Set includes:  3M static-control mat, 0.6m × 1.2m (2 ft × 4 ft)  ground wire, 4.6m (15 ft)  (The wrist strap and wrist-strap cord are <i>not</i> included. They must be ordered separately.)	9300-0797
Wrist-strap cord	1.5m (5 ft)	9300-0980
Wrist strap	Black, stainless steel with four adjustable links and 7-mm post-type connector (The wrist-strap cord is <i>not</i> included.)	9300-1383
ESD heel strap	Reusable 6 to 12 months	9300-1169
Hard-surface static-control mat*	Large, black, 1.2m × 1.5m (4 ft × 5 ft)	92175A
	Small, black, 0.9m × 1.2m (3 ft × 4 ft)	92175C
Soft-surface static-control mat*	Brown, 1.2m × 2.4m (4 ft × 8 ft)	92175B
Tabletop static-control mat*	58 cm × 76 cm (23 in. × 30 in.)	92175T
Antistatic carpet*	Small, 1.2m × 1.8m (4 ft × 6 ft)  natural color  russet color	92176A
		92176C
	Large, 1.2m × 2.4m (4 ft × 8 ft)  natural color  russet color	92176B
		92176D

\*These accessories can be ordered either through a Hewlett-Packard Sales Office or through HP DIRECT Phone Order Service. In the USA, the HP DIRECT phone number is (800) 538-8787. Contact your nearest Hewlett-Packard Sales Office for more information about HP DIRECT availability in other countries.

---

## Returning Instruments for Service

The original shipping containers and materials, or the equivalent, must be used when repackaging the mainframe with modules, or modules alone. Packaging materials identical to the original factory packaging (see Figure 1-5) can be purchased through any Hewlett-Packard office. However, if these shipping materials are not available, instruments can be repackaged for shipment using the information below.

---

**Caution** Instrument damage can result from using packaging materials other than the original shipping materials or equivalent. Never use styrene pellets as packaging materials. They do not adequately cushion the instrument or prevent it from shifting in the carton. They cause instrument damage by generating static electricity.

---

Use the following procedure to prepare the instrument for shipment:

1. Fill out a blue repair card (located at the end of this manual) and attach it to the instrument. Also send copies of any error messages and performance data recorded for the instrument. If a blue repair card is not available, send the following information with the returned instrument:
  - a. Type of service required.
  - b. Description of the problem; state if the problem is constant or intermittent.
  - c. Name and phone number of technical contact person.
  - d. Return address.
  - e. Model number of returned instrument.
  - f. Full serial number of returned instrument.
  - g. List of any accessories returned with instrument.
2. Pack the instrument in the original shipping materials (or the equivalent). However, if these are not available, instruments can be repackaged for shipment using the following instructions.
  - a. Wrap the instrument in antistatic plastic to reduce the possibility of ESD-caused damage.
  - b. For instruments that weigh less than 54 kg (120 lb), use a double-walled, corrugated cardboard carton of 159 kg (350 lb) test strength. The carton must be large enough and strong enough to accommodate the instrument. Allow at least 3 to 4 inches on all sides of the instrument for packing material.
  - c. Surround the equipment with 3 to 4 inches of packing material to protect the instrument and prevent it from moving in the carton. If packing foam is not available, the best alternative is S.D.-240 Air Cap™ from Sealed Air Corporation (Commerce, California 90001). Air Cap is a plastic sheet filled with 1-1/4 inch air bubbles. Use the pink (antistatic) Air Cap to reduce static electricity. Wrapping the instrument several times in this material should both protect the instrument and prevent it from moving in the carton.
3. Seal the carton with strong nylon adhesive tape.
4. Mark the carton "FRAGILE, HANDLE WITH CARE."
5. Retain copies of all shipping papers.



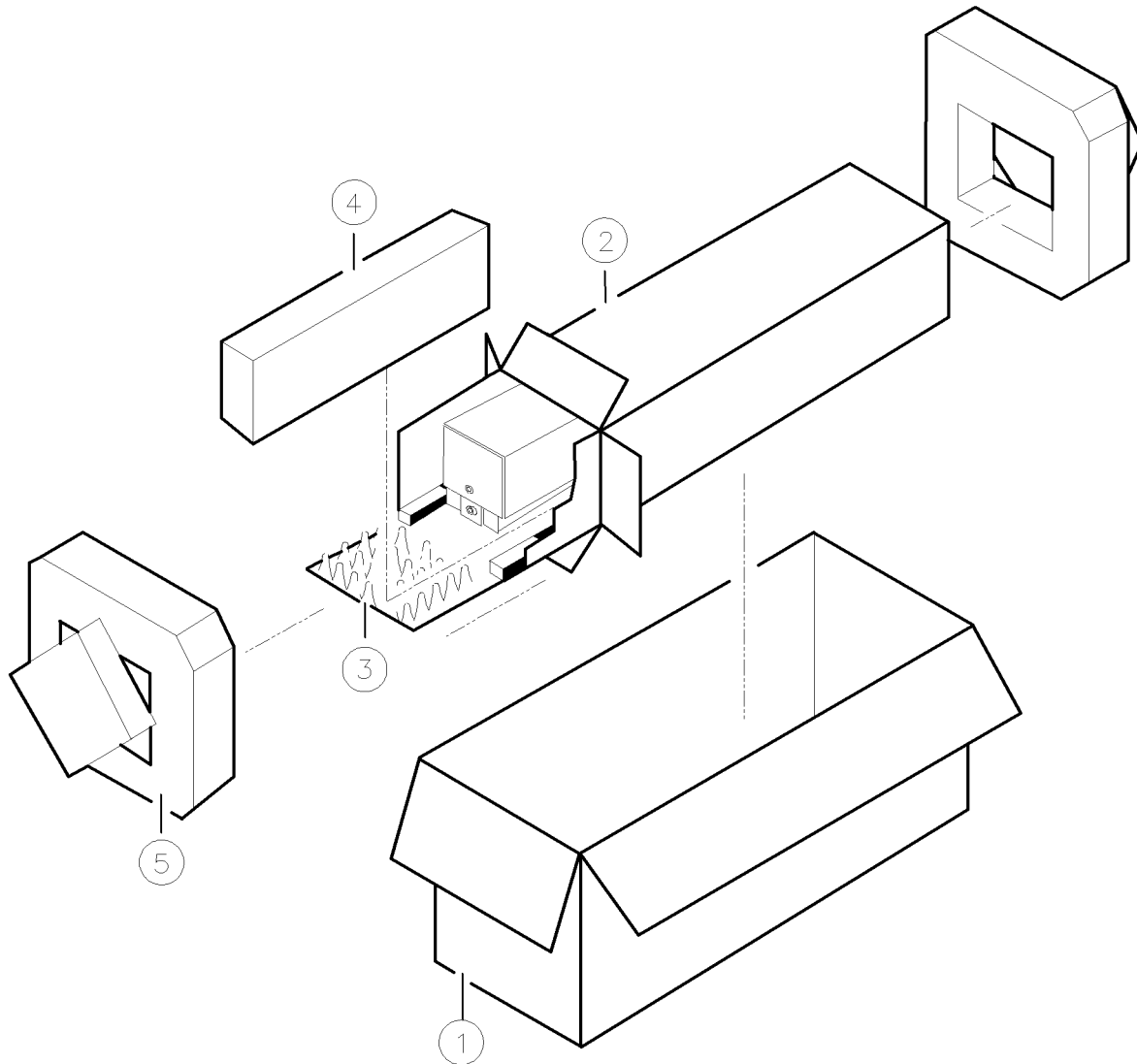

Item	HP Part Number	Qty	Description
1	9211-5118	1	Carton-Outer
2	9211-5119	1	Carton-Inner
3	5180-2369	1	Carton-Slider
4	4208-0493	2	Foam Insert
5	5180-2370	2	Foam Pad

&sigspace;  
**Figure 1-5. Packaging Materials for Modules**

---

## **Sales and Service Offices**

Hewlett-Packard sales and service offices provide complete support for Hewlett-Packard products. To obtain servicing information, or to order replacement parts, contact the nearest Hewlett-Packard Sales and Service Office listed in Table 1-3.

In any correspondence, be sure to include the pertinent information about model numbers, serial numbers, or assembly part numbers.

**Table 1-3. Hewlett-Packard Sales and Service Offices**

<p><b>IN THE UNITED STATES</b></p> <p><b>California</b> Hewlett-Packard Co. 1421 South Manhattan Ave. P.O. Box 4230 Fullerton, CA 92631 (714) 999-6700</p> <p>Hewlett-Packard Co. 301 E. Evelyn Mountain View, CA 94039 (415) 694-2000</p> <p><b>Colorado</b> Hewlett-Packard Co. 24 Inverness Place, East Englewood, CO 80112 (303) 649-5000</p> <p><b>Georgia</b> Hewlett-Packard Co. 2000 South Park Place P.O. Box 105005 Atlanta, GA 30339 (404) 955-1500</p> <p><b>Illinois</b> Hewlett-Packard Co. 5201 Tollview Drive Rolling Meadows, IL 60008 (312) 255-9800</p> <p><b>New Jersey</b> Hewlett-Packard Co. 120 W. Century Road Paramus, NJ 07653 (201) 265-5000</p> <p><b>Texas</b> Hewlett-Packard Co. 930 E. Campbell Rd. Richardson, TX 75081 (214) 231-6101</p>	<p><b>IN AUSTRALIA</b> Hewlett-Packard Australia Ltd. 31-41 Joseph Street Blackburn, Victoria 3130 895-2895</p> <p><b>IN CANADA</b> Hewlett-Packard (Canada) Ltd. 17500 South Service Road Trans-Canada Highway Kirkland, Quebec H9J 2X8 (514) 697-4232</p> <p><b>IN FRANCE</b> Hewlett-Packard France F-91947 Les Ulis Cedex Orsay (6) 907-78-25</p> <p><b>IN GERMAN FEDERAL REPUBLIC</b> Hewlett-Packard GmbH Vertriebszentrale Frankfurt Berner Strasse 117 Postfach 560 140 D-6000 Frankfurt 56 (0611) 50-04-1</p> <p><b>IN GREAT BRITAIN</b> Hewlett-Packard Ltd. King Street Lane Winnersh, Wokingham Berkshire RG11 5AR 0734 784774</p> <p><b>IN OTHER EUROPEAN COUNTRIES</b> Hewlett-Packard (Schweiz) AG Allmend 2 CH-8967 Widen (Zurich) (0041) 57 31 21 11</p>	<p><b>IN JAPAN</b> Yokogawa-Hewlett-Packard Ltd. 29-21 Takaido-Higashi, 3 Chome Suginami-ku Tokyo 168 (03) 331-6111</p> <p><b>IN PEOPLE'S REPUBLIC OF CHINA</b> China Hewlett-Packard, Ltd. P.O. Box 9610, Beijing 4th Floor, 2nd Watch Factory Main Bldg. Shuang Yu Shu, Bei San Huan Rd. Beijing, PRC 256-6888</p> <p><b>IN SINGAPORE</b> Hewlett-Packard Singapore Pte. Ltd. 1150 Depot Road Singapore 0410 273 7388 Telex HPSGSO RS34209 Fax (65) 2788990</p> <p><b>IN TAIWAN</b> Hewlett-Packard Taiwan 8th Floor, Hewlett-Packard Building 337 Fu Hsing North Road Taipei (02) 712-0404</p> <p><b>IN ALL OTHER LOCATIONS</b> Hewlett-Packard Inter-Americas 3495 Deer Creek Rd. Palo Alto, California 94304</p>
--	---	---

## Installation

---

This chapter contains information needed to install the HP 70907A/B External Mixer Interface module (EMIM) into an existing HP 71210C system and then check basic module operation.

For more detailed information about system configuration and addressing, refer to the Installation and Verification Manual for the system master (for example, HP 70900B Local Oscillator).

Installing the EMIM requires the following steps:

1. Addressing the module.
2. Installing the module in the mainframe.
3. Connecting the rear-panel cables.

When properly installed, the EMIM obtains both power and interface-bus control through the module's rear-panel mainframe/module interconnect. After the EMIM is installed, use "Checking Module Operation" in this chapter to make sure that it has been properly installed.

The examples of addressing and cable connections in this chapter are for an HP 70907A/B installed in an HP 71210C system. The system shown in Figures 2-1 and 2-4 contains the following equipment:

- HP 70907B External Mixer Interface module
- HP 71210C High Sensitivity Microwave Spectrum Analyzer, which consists of the following:
  - HP 70001A Mainframe
  - HP 70004A Display
  - HP 70310A Precision Frequency Reference
  - HP 70900B Local Oscillator
  - HP 70902A IF Section
  - HP 70903A IF Section
  - HP 70908A RF Section

---

**Caution** To prevent connector damage and ensure proper electrical connection, all APC 3.5 and SMA connectors must be torqued 7 to 10 inch-pounds. Do not exceed 10 inch-pounds.

---

---

## Addressing the Module

The EMIM needs an appropriate Hewlett-Packard Modular System Interface Bus (HP-MSIB) address to be able to communicate with the master of the HP 70000 Modular Measurement System. The EMIM's address is set using its ROW and COLUMN address switches.

---

**Note** The EMIM can be used in most system configurations without changing the factory-preset address.

---

### Determining the HP-MSIB Address

The EMIM has a factory-preset HP-MSIB address of 5, 18 (row 5, column 18). Figure 2-1 shows the address map for an EMIM in an HP 71210C system. The addresses in this figure are the factory-preset addresses for the modules. When a system containing an EMIM is turned on, the system master selects the front end (EMIM or RF section) that is located lowest in the address map. As seen in the figure below, the HP 70907B is lower in the address map than the HP 70908A. Therefore, the EMIM will be selected when the system is turned on.

7			70310A FREQ REF	
6		70908A RF SECT		
5		70907B EMIM		
4		70903A IF SECT		
3				
2		70902A IF SECT		
1				
0		70900B LO/CTLR HP-IB18		
	17	18	19	20
	COLUMN			

**Figure 2-1. Address Map for an EMIM in an HP 71210C System**

If the EMIM is going to be used in an HP 70000 Modular Spectrum Analyzer System where the modules all have their factory-preset addresses, the EMIM probably will not need to have its factory-preset address changed. However, if the factory-preset addresses of the modules in the system have been changed, or if the EMIM is being used in another type of HP 70000 Modular Measurement System, the EMIM's factory-preset address may need to be changed. For more information about HP-MSIB addressing rules, refer to the Installation and Verification Manual for the system master (for example, HP 70900B Local Oscillator).

## Setting the HP-MSIB Address Switches

The EMIM's address switches are located on the right side of the module. Table 2-1 gives the decimal value for each address switch when the switch is set to binary 1 (on).

**Table 2-1. Decimal Equivalents of Row and Column Address Switches**

Address Switch	Decimal Value
<b>Row</b>	
3*	4
2	2
1*	1
<b>Column</b>	
5*	16
4	8
3	4
2*	2
1	1
*These switches are factory-preset to binary 1 (on), resulting in an HP-MSIB address of 5, 18 (row 5, column 18).	

Use the procedure below to change the address switches:

1. Set the three ROW switches to the binary value of the module's HP-MSIB row number. For example, if the row number is 5, change the switches to binary 101 as shown in Figure 2-2.
2. Set the five COLUMN switches to the binary value of the module's HP-MSIB column number. For example, if the column number is 18, change the switches to binary 10010 as shown in Figure 2-2.

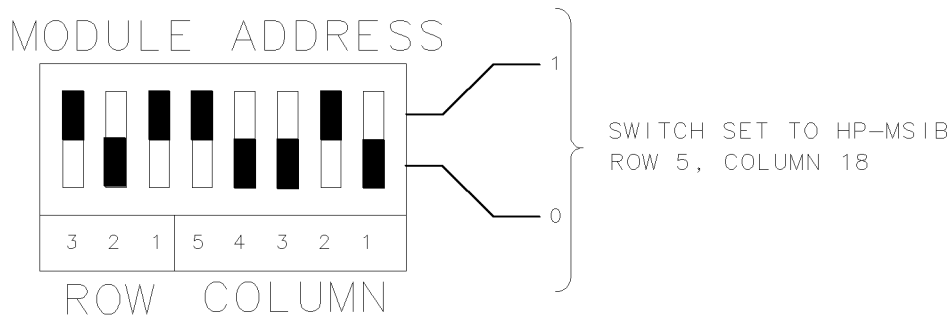

**Figure 2-2. HP 70907A/B Address Switches**

---

## Installing the Module in the Mainframe

The EMIM needs to be installed in an HP 70000 series mainframe before it will operate. Follow the procedure below to install the module into the mainframe. See Figure 2-3 for identification of the module and mainframe parts called out in the procedure.

1. Turn the mainframe LINE switch off.
2. Open the mainframe front-panel door.
3. Slide the module into the mainframe.
4. Press against the module front panel while tightening the module latch with an 8 mm hex-ball driver.
5. Close the mainframe front-panel door.

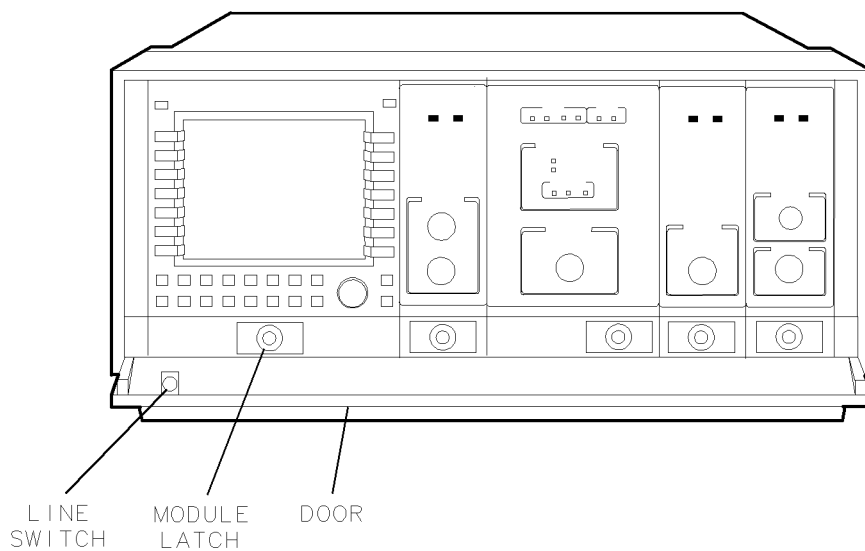

**Figure 2-3. Module Installation in Mainframe**

---

## Connecting the Rear-Panel Cables

This section contains the instructions for connecting the EMIM when it is used in an existing HP 71210C system. For HP 71210C system configuration information, refer to the Installation and Verification Manual for the system's master.

Figure 2-4 illustrates the rear-panel cable connections for the HP 71210C system with an EMIM added. Make the following changes and additions to the HP 71210C system cabling when an EMIM is added:

- Disconnect the cable between HP 70903A 21.4 MHz IN and HP 70908A 21.4 MHz OUT.
- Disconnect the RF-section end of the cable connected between HP 70900B TUNE SPAN and HP 70908A TUNE SPAN. Connect an SMB tee (1250-1391) to HP 70908A TUNE SPAN, then connect the cable from HP 70900B TUNE SPAN to the tee.
- Connect the following ports with the cables listed:
  - HP 70907B LO IN to HP 70908A 1ST LO OUT. (5021-5493)
  - HP 70907B TUNE SPAN to the tee on HP 70908A TUNE SPAN. (5061-9017)
  - HP 70907B 300 MHz IN to HP 70900B 300 MHz OUT 2. (5061-9021)
  - HP 70907B 21.4 MHz OUT to HP 70903A 21.4 MHz IN. (5061-9021)
  - HP 70907B 21.4 MHz IN to HP 70908A 21.4 MHz OUT. (5061-9017)



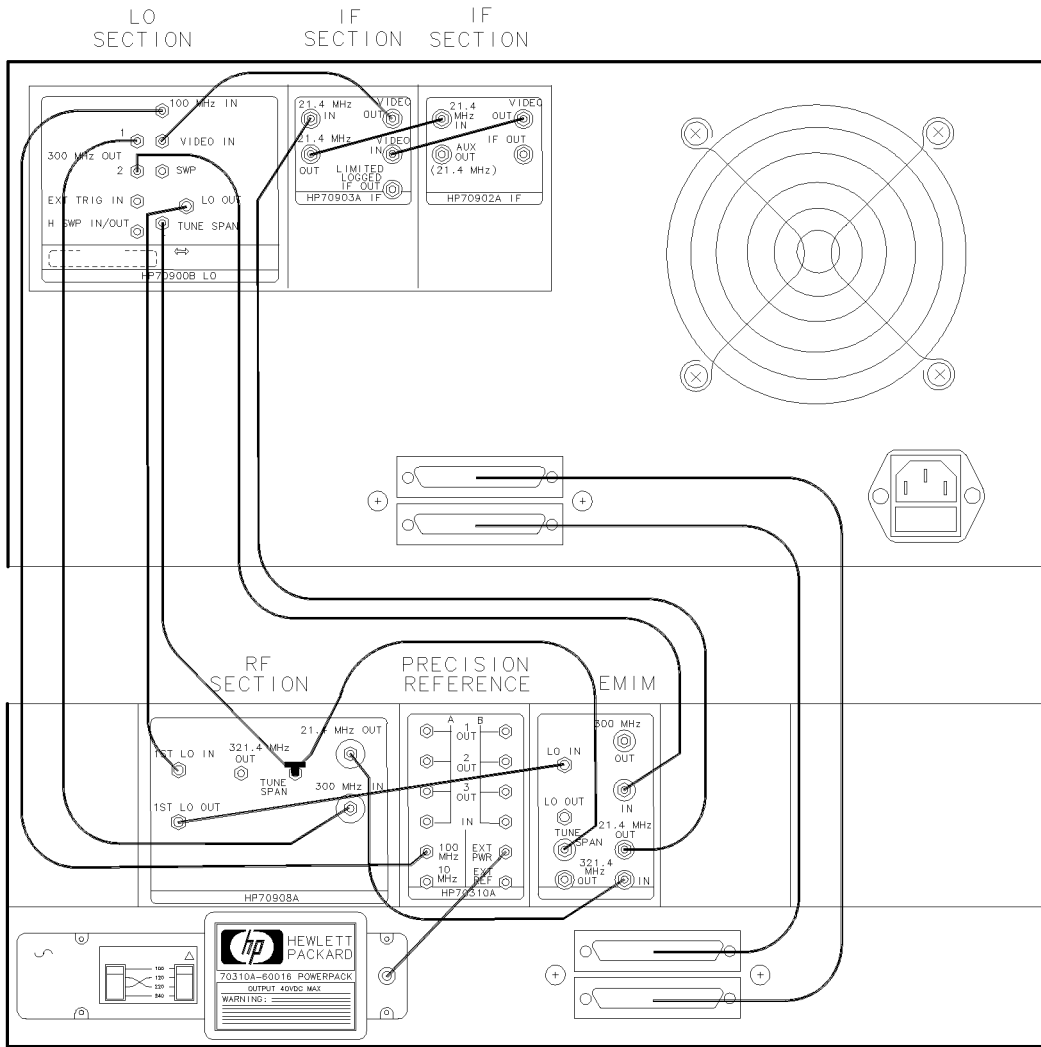

Figure 2-4. Rear-Panel Cabling for an EMIM in an HP 71210C System

---

## Checking Module Operation

The operation of the HP 70907A/B in an HP 70000 Modular Spectrum Analyzer system is checked by examining the front-panel LEDs and by checking for error messages after the module's power-on self-test has run. Recheck installation if there seems to be a problem with module operation, but neither the front-panel LEDs nor error messages indicate a problem.

### Examining the Front-Panel LEDs

The power-on self-test runs automatically when power is first applied to the module. The front-panel LEDs flash on and then off during the

self-test. Immediately after the self-test has run, the ACT LED should be *on* and the ERR LED should be *off*. Refer to Chapter 5, "Troubleshooting," if the LEDs' status is different than that listed above.

### Checking for Error Messages

Perform this procedure to display any error messages present for the system.

1. Press **DISPLAY**, then **REPORT ERRORS**.
2. The error messages for the system will be visible on the display screen. Note any error messages that have 70907A or 70907B as part of the error code. The last two numbers of the error code are the module's HP-MSIB address (5, 18), and will be different if the factory-preset address has been changed.
3. If any error messages are displayed, refer to Chapter 5 for troubleshooting information. If no error messages are present, the HP 70907A/B is operating properly.



## Specifications

---

This chapter contains module characteristics for the HP 70907A and HP 70907B External Mixer Interface modules. Refer to the Installation and Verification Manual for the system master (for example, HP 70900B) for full system specifications and system specifications that are modified when an HP 70907A/B is added to a system.

This chapter contains both specifications and characteristics. Characteristics are in *italics* and are identified with the word *characteristic*. The terms “specifications” and “characteristics” are defined below:

- Specifications** describe warranted performance over the temperature range of 0°C to +55°C (unless otherwise noted) after 1 hour of continuous operation. Specifications apply after system temperatures have stabilized and self-calibration routines have run.
- Unless otherwise noted, corrected limits are given when a specification range is improved with error-correction routines. All specifications that are qualified by an output-power setting refer to that setting.
- Typical performance**, where listed, is *not warranted*, but indicates performance which most units will meet.
- Characteristics** provide useful, but *nonwarranted*, functional and performance information.
- Nominal values** indicate the expected, but *nonwarranted*, value of the denoted parameter.

---

# HP 70907A Module Specifications and Characteristics

## Front-Panel Inputs and Outputs

For HP 70907A front-panel input and output specifications and characteristics, refer to the Installation and Verification manual for the system master (for example, HP 70900B Local Oscillator).

## Rear-Panel Inputs and Outputs

### LO IN

<i>Frequency (characteristic)</i> .....	3.0 to 6.6 GHz
<i>Input Power (characteristic)</i> .....	-0.5 dBm to +19.0 dBm
<i>Impedance</i> .....	50Ω (nominal)

### LO OUT

<i>Frequency Range (characteristic)</i> .....	3.0 to 6.6 GHz
<i>Output Power (characteristic)</i> .....	+2.6 to 13.9 dBm
<i>VSWR (characteristic)</i> .....	≤2.3
<i>Impedance</i> .....	50Ω (nominal)

### TUNE SPAN

<i>Voltage (characteristic)</i> .....	4.5 to 9.9 V
<i>Sensitivity (characteristic)</i> .....	1.5 V/GHz
<i>Impedance</i> .....	>10 kΩ (nominal)

### 321.4 MHz OUT

The output tracks 21.4 MHz OUT with an offset of  $-20 \pm 2$  dB.

<i>Frequency Range (characteristic)</i> .....	321.4 ± 25 MHz
<i>Frequency Response (characteristic)</i> .....	+1.0, -2.0 dB typical
<i>Return Loss (characteristic)</i> .....	9 dB
<i>Impedance</i> .....	50Ω (nominal)

### 300 MHz OUT

<i>Frequency (characteristic)</i> .....	300 MHz
<i>Output Power (characteristic)</i> .....	0 dBm ± 1 dB
<i>VSWR at 300 MHz (characteristic)</i> .....	≤ 1.5
<i>Impedance</i> .....	50Ω (nominal)

### 300 MHz IN

<i>Frequency (characteristic)</i> .....	300 MHz ± 10 kHz
<i>Input Power (characteristic)</i> .....	-2 to +2 dBm
<i>VSWR at 300 MHz (characteristic)</i> .....	≤ 1.5
<i>Impedance</i> .....	50Ω (nominal)

### 21.4 MHz OUT

<i>Center Frequency (characteristic)</i> .....	21.4 MHz
<i>VSWR (characteristic)</i>	
<i>at 21.4 MHz</i> .....	≤1.5
<i>at 21.4 MHz ± 5.0 MHz</i> .....	≤1.9
<i>Impedance</i> .....	50Ω (nominal)

### 21.4 MHz IN

<i>Frequency (characteristic)</i> .....	21.4 MHz ± 5 MHz
<i>Maximum Input Power (characteristic)</i> .....	-3.5 dBm
<i>VSWR (characteristic)</i> .....	≤1.5
<i>Impedance</i> .....	50Ω (nominal)

## General Specifications and Characteristics

<i>Temperature</i>	
<i>Operation</i> .....	0°C to +55°C
<i>Storage</i> .....	-10°C to +75°C
<i>HP 70907A Weight (characteristic)</i> .....	2.8 kg (6.2 lb)
<i>HP 70907A Dimensions (characteristic)</i> .....	1/8-width module

---

# HP 70907B Module Specifications and Characteristics

## Front-Panel Inputs and Outputs

For HP 70907B front-panel input and output specifications and characteristics, refer to the Installation and Verification manual for the system master (for example, HP 70900B Local Oscillator).

## Rear-Panel Inputs and Outputs

### LO IN

<i>Frequency (characteristic)</i> .....	3.0 to 6.6 GHz
<i>Input Power (characteristic)</i> .....	-0.5 dBm to +19.0 dBm
<i>Impedance</i> .....	50Ω (nominal)

### LO OUT

<i>Frequency Range (characteristic)</i> .....	3.0 to 6.6 GHz
<i>Output Power (characteristic)</i> .....	+2.6 to 13.9 dBm
<i>VSWR (characteristic)</i> .....	≤2.3
<i>Impedance</i> .....	50Ω (nominal)

### TUNE SPAN

<i>Voltage (characteristic)</i> .....	4.5 to 9.9 V (floating)
<i>Sensitivity (characteristic)</i> .....	1.5 V/GHz
<i>Impedance</i> .....	>100 kΩ (nominal)

### 321.4 MHz OUT

The output tracks 21.4 MHz OUT with an offset of  $-20 \pm 2$  dB.

<i>Frequency Range (characteristic)</i> .....	321.4 ± 25 MHz
<i>Frequency Response (characteristic)</i> .....	+1.0, -2.0 dB typical
<i>Return Loss (characteristic)</i> .....	9 dB
<i>Impedance</i> .....	50Ω (nominal)

### 300 MHz OUT

<i>Frequency (characteristic)</i> .....	300 MHz
<i>Output Power (characteristic)</i> .....	0 dBm ± 1 dB
<i>VSWR at 300 MHz (characteristic)</i> .....	≤ 1.5
<i>Impedance</i> .....	50Ω (nominal)

### 300 MHz IN

<i>Frequency (characteristic)</i> .....	300 MHz ± 10 kHz
<i>Input Power (characteristic)</i> .....	-2 to +2 dBm
<i>VSWR at 300 MHz (characteristic)</i> .....	≤ 1.5
<i>Impedance</i> .....	50Ω (nominal)

### 21.4 MHz OUT

<i>Center Frequency (characteristic)</i> .....	21.4 MHz
<i>VSWR (characteristic)</i>	
<i>at 21.4 MHz</i> .....	≤1.5
<i>at 21.4 MHz ± 5.0 MHz</i> .....	≤1.9
<i>Impedance</i> .....	50Ω (nominal)

### 21.4 MHz IN

<i>Frequency (characteristic)</i> .....	21.4 MHz ± 5 MHz
<i>Maximum Input Power (characteristic)</i> .....	-3.5 dBm
<i>VSWR (characteristic)</i> .....	≤1.5
<i>Impedance</i> .....	50Ω (nominal)

### General Specifications and Characteristics

<i>Temperature</i>	
<i>Operation</i> .....	0°C to +55°C
<i>Storage</i> .....	-10°C to +75°C
<i>HP 70907B Weight (characteristic)</i> .....	2.8 kg (6.2 lb)
<i>HP 70907B Dimensions (characteristic)</i> .....	1/8-width module





## Verification

---

The HP 70907A/B External Mixer Interface module (EMIM) does not have any module specifications. Operation of the EMIM in the system can be verified by using the system master's operation verification software.

System-level performance specifications for the EMIMs, including system specifications that are modified when an EMIM is added to a system, are in the Installation and Verification Manual for the system master (for example, HP 70900B Local Oscillator). System-level testing of systems controlled by an HP 70900 local oscillator can be accomplished in two ways:

- Run the system operation-verification tests, using revision C.00.00 or greater. (For system operation verification, refer to the Installation and Verification Manual for the system's master.)
- Run the HP 11990A system tests, using revision B.04.00 or greater. The HP 11990A software and documentation are available through Hewlett-Packard Sales Offices.

System-level testing of systems controlled by other system masters can be accomplished by using the system operation-verification tests given in the Installation and Verification Manual for that system master. HP 11990 Series system tests can also be used, if they are available for that system master.



## Troubleshooting

---

The information in this chapter is designed to help determine whether an error is being caused by the HP 70907A/B External Mixer Interface module (EMIM). This chapter contains information about EMIM front-panel LEDs, and a listing of the error codes for the EMIM. For more detailed HP 70907A/B troubleshooting information, refer to the *HP 70907A/B External Mixer Interface Service Manual*.

If the error is not caused by the EMIM, refer to the Installation and Verification Manual for the system master (for example, HP 70900B) for more troubleshooting information.

---

### Front-Panel LEDs

The HP 70907A/B External Mixer Interface module has two front-panel LEDs.

- The ACT (active) LED lights when the module has an active keyboard link to an HP 70000 Modular Measurement System master and is being activated by that master. If there is no display in the system, the ACT LED will not light even if the previous requirements are met. The ACT LED being lit does *not* indicate an error.
- The ERR (error) LED lights when there is an error condition.

---

### Error Messages

The error codes generated by the HP 70907A/B External Mixer Interface module are listed below in numerical order. For a complete list of all system error messages, refer to the Installation and Verification Manual for the system master.

Error Types	Error Numbers
Usage/Operating .....	2000 to 2999
Hardware Warning .....	6000 to 6999
Hardware Broken .....	7000 to 7999

## Usage/Operating Errors

These errors occur when the instrument is used incorrectly.

- 2000 **Rom check error** — A test of the module ROM has failed. The most probable cause is faulty HP 70907A/B hardware.
- 2001 **Illegal Cmd** — This error usually occurs in response to a user-generated system protocol error: the module has encountered a command that it does not recognize. This can be caused by the system master's sending such a command, however; if the error is repeated when the module is moved to another mainframe, the most probable cause is faulty HP 70907A/B hardware.
- 2002 **Illegal parameter** — Refer to 2001 **Illegal Cmd**.
- 2006 **Param out of range** — Refer to 2001 **Illegal Cmd**.
- 2009 **Protocol error** — Refer to 2001 **Illegal Cmd**.
- 2026 **Check mixer bias** — This error occurs in response to an improper load impedance on the front-panel mixer-bias port. If the impedances are correctly matched, the most probable cause is faulty HP 70907A/B hardware. (This error message can be generated only when the mixer-bias supply is activated.)

## Hardware Warning Errors

These error codes report the status of the HP 70907A/B hardware or indicate that some of the hardware may be broken. These error codes indicate that measurement accuracy may be impaired.

- 6000 **EAROM unprotected** — The write-protect switch on the HP 70907A/B module's A4 Power Supply/Control board assembly is set to the write position. If this error occurs when the switch is in the protect position, the most probable cause is faulty HP 70907A/B hardware.

## Hardware Broken Errors

The following error codes are generated in response to hardware or firmware failures within the modules.

- 7001 **L0 unlevelled** — The output power is too low from the A5 Leveling Amplifier assembly's primary LO output port. The most probable cause is faulty HP 70907A/B hardware.
- 7004 **300 MHz error** — This error occurs when the power level is too low at the rear-panel 300 MHz input. Verify that the 300 MHz input signal has a power level between -1 dBm and +1 dBm. If the input power is correct, the most probable cause is faulty HP 70907A/B hardware.
- 7005 **321.4 MHz error** — This error occurs when 321.4 MHz IF power level is too low on the A3 Last Converter board assembly. This error is usually accompanied by error number 7006 **21.4 MHz error**. The most probable cause is faulty HP 70907A/B hardware.
- 7006 **21.4 MHz error** — This error occurs when 21.4 MHz IF power level is too low on the A3 Last Converter board assembly. This error is usually accompanied by error number 7005 **321.4 MHz error**. The most probable cause is faulty HP 70907A/B hardware.

# Index

---

## A

- accessories
  - cables, 1-5
  - electrostatic discharge, 1-12
- ACT LED, 1-6
- address map, 2-2
- address switches
  - decimal value, 2-3
  - location, 2-3
  - setting, 2-3

## C

- cables, 1-5
  - rear-panel connections, 2-5-6

## E

- electrostatic discharge (ESD), 1-10-12
- ERR LED, 1-6
- error codes, 5-1-2
- error lights, 1-6, 5-1

## H

- HP 70907A/B
  - installing in mainframe, 2-4
  - rear-panel cable connections, 2-5-6
- HP-MSIB
  - address, 2-2
  - connector, 1-8

## I

- input and output connectors, 1-8

## L

- LEDs, 1-6
- LO firmware compatibility
  - HP 70907A, 1-2
  - HP 70907B, 1-2

## M

- module configuration, 2-1
- module errors, 5-1
- module-operation checks, 2-7

## P

- packaging, 1-13
- PC board connector cleaning, 1-10

## R

- rear-panel cable connections, 2-5-6

## S

- sales and service offices, 1-15
- select input
  - correct HP-MSIB address, 2-2
- serial-number label, 1-4
- shipping materials, 1-13
- static-safe work station, 1-10
- status and error LEDs, 1-6, 5-1
- sweeptime, 1-2
- system-level testing, 4-1

